

June 11, 1998

Mr. Stephen Dwyer  
c/o Robert Sanregret, Esq.  
17621 Irvine Blvd., #100  
Tustin, CA 92780

Dear Mr. Dwyer:

This letter responds to the Petition you filed pursuant to Section 2.206 of Title 10 of the Code of Federal Regulations (10 CFR 2.206) on April 25, 1997. In your Petition, you specify your concerns about the ability of the San Onofre Nuclear Generating Station (SONGS) steam generators to withstand a major seismic event. Specifically, you stated that the ability of the SONGS steam generators to withstand a major seismic event is seriously compromised by the degradation recently observed in the SONGS Unit 3 steam generator internal tube supports (eggcrate supports). You requested an investigation to determine if Unit 2 has experienced degradation similar to that found in Unit 3. You also stated that further seismic analysis should be performed for the SONGS steam generators and that a retrofitting upgrade of the steam generator supports could be accomplished at this time.

On June 26, 1997, the staff of the U.S. Nuclear Regulatory Commission acknowledged receiving your Petition and stated that pursuant to 10 CFR 2.206 of the Commission's regulations, your Petition was being referred to me for action and that it would be acted upon within a reasonable time. You were also informed that there was insufficient evidence to conclude that a substantial public health and safety hazard existed that warranted the immediate action you requested.

Several of the actions requested in your Petition were completed by the SONGS licensee in the normal course of assuring the continued safety of the SONGS units. The steam generators in SONGS Unit 3 were inspected to quantify the amount of eggcrate support degradation during its 1997 refueling outage, and these inspections were repeated during the recently completed mid-cycle outages on both units. Detailed analyses were performed by the licensee to verify that the eggcrate supports would continue to perform their intended safety function for all postulated design-basis accidents, including the safe shutdown earthquake loading. These activities, and the staff's review, are described in the enclosed Director's Decision (DD-98-06). For the reasons contained in the Director's Decision, the staff disagrees with your contention that the ability of the SONGS steam generators to withstand a major seismic event is seriously compromised, and, therefore, your request for a retrofitting upgrade of the steam generators is denied.

A copy of this Decision will be filed with the Secretary of the Commission for the Commission to review in accordance with 10 CFR 2.206(c). As provided by this regulation, the Decision will constitute the final action of the Commission 25 days after the date of issuance of the Decision unless the Commission, on its own motion, institutes a review of the Decision within that time. The documents cited in the enclosed Decision that are not commercially available are available for review at the Local Public Document Room for SONGS located at the Main Library, University of California, Irvine, California 92713.

Mr. Stephen Dwyer

- 2 -

I have also enclosed a copy of the notice "Issuance of Director's Decision Under 10 CFR 2.206," which includes the complete text of DD-98-06 that is being filed with the Office of the Federal Register for publication.

Sincerely,

Original signed by

Samuel J. Collins, Director  
Office of Nuclear Reactor Regulation

Docket Nos. 50-361  
and 50-362  
(10 CFR § 2.206)

Enclosures: 1. Director's Decision  
2. Notice

cc w/encls: See next page

UNITED STATES OF AMERICA  
NUCLEAR REGULATORY COMMISSION  
OFFICE OF NUCLEAR REACTOR REGULATION

Samuel J. Collins, Director

In the Matter of	)	
	)	
SOUTHERN CALIFORNIA EDISON COMPANY	)	Docket Nos. 50-361
	)	and 50-362
(San Onofre Nuclear Generating	)	10 CFR § 2.206
Station, Units 2 and 3	)	

DIRECTOR'S DECISION UNDER 10 CFR § 2.206

I. INTRODUCTION

By e-mail dated April 25, 1997, Stephen Dwyer (Petitioner) requested that the Nuclear Regulatory Commission (NRC) take action with regard to San Onofre Nuclear Generating Station (SONGS) regarding his concerns about the ability of the SONGS steam generators to withstand a major seismic event.<sup>1</sup> Specifically, the Petitioner stated that the ability of the SONGS steam generators to withstand a major seismic event is seriously compromised by the degradation observed in the SONGS Unit 3 steam generator internal tube supports (eggcrate supports) during its 1997 refueling outage. The Petitioner requested an investigation to

---

<sup>1</sup>The Petitioner sought to add this concern to his Petition dated September 22, 1996, wherein he requested the NRC to shut down the SONGS facility "as soon as possible" pending a complete review of the seismic design of the SONGS units based on information gathered from the Landers and Northridge earthquakes. By letter dated June 26, 1997, the NRC advised the Petitioner that his e-mail request dated April 25, 1997, concerning the ability of the SONGS steam generators to withstand a major seismic event, would be treated as a separate 10 CFR 2.206 Petition. The Director's Decision (DD-97-23) issued by the NRC on September 19, 1997, denied the Petitioner's September 22, 1996, request to shut down the SONGS units, providing a detailed discussion of the adequacy of the seismic licensing basis for the SONGS facility.

determine if Unit 2 has experienced degradation similar to that found in Unit 3 and also stated that further seismic analysis should be performed for the SONGS steam generators and that a retrofitting upgrade of the steam generator supports could be accomplished at this time. On June 26, 1997, the NRC staff acknowledged receipt of the Petition as a request pursuant to Section 2.206 of Title 10 of the Code of Federal Regulations (10 CFR 2.206) and informed the Petitioner that there was insufficient evidence to conclude that immediate action was warranted. Notice of the receipt of the Petition indicating that a final decision with respect to the requested action would be forthcoming within a reasonable time was published in the Federal Register on July 3, 1997 (62 FR 36085).

My Decision in this matter follows.

## II. DISCUSSION

### A. Request for an Investigation to Determine if SONGS Unit 2 Has Experienced Eggcrate Degradation Similar to Unit 3.

#### 1. Background

The SONGS units utilize Combustion Engineering Model 3410 recirculating steam generators. This model of steam generator contains 9,350 Inconel 600 (ASME Material Specification SB-163) U-tubes with a nominal diameter and wall thickness of 0.75 and 0.048 inch, respectively. Secondary side tube support structures consist of seven horizontal full eggcrate supports, three horizontal partial eggcrate supports, and upper bundle supports (i.e., two batwing diagonal supports and seven vertical supports). The materials used for fabrication of the steam generator vessels and internals (including tube supports) are low-alloy and carbon steels, respectively. Figure 1 is a simplified cross-sectional diagram of the SONGS steam generators that clearly displays the 10 eggcrate support levels, and Figure 2 is a three-dimensional representation of the steam generators that gives additional structural detail.

The eggcrate supports consist of 1- and 2-inch carbon steel strips interlocked perpendicular to each other as shown in Figure 3. The eggcrate supports limit lateral motion of the tubes and, at the same time, allow free flow of fluid around the tubes.

During the 1997 refueling outage for SONGS Unit 3, the licensee discovered that portions of the eggcrate supports had experienced degradation, ranging from minor wastage of the eggcrate material to severe thinning in localized areas. The significant degradation observed during this refueling outage was confined mainly to the periphery locations of the eggcrate supports. The secondary sides of the steam generators in both units were inspected during their 1997 refueling outages and during their 1998 mid-cycle outages and, as discussed below, significant degradation was limited to the periphery locations of the SONGS Unit 3 eggcrate supports.

The licensee has extensively researched the cause of the eggcrate degradation and has concluded that the degradation was caused by a form of flow accelerated corrosion (FAC), a general term describing processes that use assistance from fluid flow to remove the protective oxide layer from base material. Removal of the protective oxide layer exposes the base material to the fluid environment, allowing further material removal through corrosion and/or erosion processes. The carbon steel eggcrate material utilized in the SONGS steam generators can be susceptible to FAC in the presence of sufficiently high fluid velocities.

The licensee concluded that the FAC occurred during recent operation of Unit 3 primarily as a result of steam generator secondary side increased fluid velocities caused by the buildup of deposits on the steam generator tubes. This buildup of deposits on the tubes significantly reduced the available flow area within the tube bundle causing flow diversion to the periphery of the tube bundle. The flow diversion to the periphery was also affected by the increased steam quality of the fluid within the tube bundle. The buildup of deposits on the

tubes changed the heat transfer characteristics of the tubes causing the steam quality to increase in the central region of the steam generators. This resulted in an increase of the flow resistance in the central portions of the steam generator, forcing more flow to the peripheral regions, with resulting higher velocities. The resulting large velocity gradients at the periphery initiated vortices which further elevated local velocities that were capable of dislodging the protective oxide layer of the eggcrate material and initiating erosive FAC.

The chemical cleaning of the SONGS Units 2 and 3 steam generators during the 1997 refueling outages removed the deposit buildup and restored fluid flow to their original design values (i.e., nominal conditions). The licensee stated in its October 17, 1997, letter that with the flow area restored to nominal conditions, the high fluid velocities that lead to FAC would no longer exist, thus stabilizing eggcrate support degradation. The licensee has also made changes to the chemistry control program for the secondary system at SONGS Units 2 and 3 to reduce the feedwater iron transport. This is expected to prevent the level of deposit buildup observed in the steam generators before chemical cleaning was done in 1997. The staff concurs with the licensee's evaluation that FAC was caused by deposit buildup on the steam generator tubes and that removal of the deposits should restore the steam generator secondary fluid flow to within nominal design values, thereby eliminating continued significant eggcrate degradation. To confirm that FAC has been stopped by the chemical cleaning of the steam generators, and to assure that no significant degradation of the eggcrate support structures goes undetected, the licensee has committed to conduct periodic inspections of the secondary side of the steam generators in both units during future outages. The licensee will conduct periodic inspections of the secondary side of the steam generators to check the level of deposit buildup on the tubes and to verify that future degradation of the eggcrates, if any, remains within the assumptions used in the analysis to demonstrate continued operability of the steam

generators (discussed later in this Decision).

## 2. Description of the Eggcrate Inspections

The SONGS licensee inspected the steam generator secondary side support structures, which include the eggcrate supports, in both SONGS units during their 1997 refueling outages and during their 1998 mid-cycle outages. The results of these inspections are contained in the licensee's letters dated May 16, 1997, and June 5, 1997 (SONGS Unit 2 and Unit 3 refueling outage inspections results, respectively), and letters dated March 10, 1998, and April 15, 1998 (SONGS Unit 2 and Unit 3 1998 mid-cycle outages, respectively).

The objective of the inspections for both units was to provide video documentation of all areas in which indications of support bar degradation was suspected and to verify that other areas did not exhibit these same characteristics. The extent and results of these video inspections are summarized below.

The inspection of the secondary side of each steam generator was divided into six areas: (1) general inspection, (2) inner tube bundle, (3) batwings and vertical straps, (4) eggcrate periphery, (5) eggcrate interior (blowdown lane), and (6) stay cylinder. Each of these areas was inspected to the extent necessary to understand, with a high degree of confidence, the amount of degradation present. The majority of these areas did not exhibit any significant degradation and therefore the design function of the support structures was not adversely impacted.

The general inspections were performed in the steam generators from the top of the moisture separator can deck and included the general area, U-bend, and annulus regions. The areas inspected included I-beams, I-beam to shroud attachments, drains, vertical supports, batwings and the batwing hoop, and baffle anti-rotational keys. These inspections identified no significant degradation in either unit in these areas.

The inner tube bundle consists of that area between the outer or peripheral tubes to the inner tubes of the stay cylinder. The inner bundle inspections were performed in both steam generators from the can deck. A small camera was dropped down in between the tubes in a number of different locations to assess the general material condition of the eggcrates away from the periphery area. For the steam generators in both units, the inspections indicated that the inner bundle did not exhibit the degraded characteristics of the periphery eggcrates found in the Unit 3 steam generators during the 1997 refueling outage.

No indications of thinning were detected during the inspections of the interior batwing and vertical strips on either unit.

Comprehensive peripheral eggcrate inspections were performed in both steam generators in the two units from the can deck. This included the lattice bars and tube to lattice bar interfaces at each eggcrate. The area near the periphery of the eggcrate supports in the Unit 3 steam generators experienced the maximum thinning, as shown in Figure 3 and discussed above. As stated earlier, minor isolated instances of thinning were observed in the peripheral eggcrate locations in the SONGS Unit 2 steam generators, but overall the thinning was considerably less than that observed on SONGS Unit 3.

Inspections of the blowdown lane eggcrates were performed in the steam generators through the 6-inch handhole at the secondary face of the tubesheet from the handhole to the stay cylinder. This included the lattice bars and the eggcrate rings. The inspection scope was to sample the eggcrate area nearest the tubes on both the hot- and cold-leg sides of the blowdown lane. Minor amounts of eggcrate degradation were found in the steam generators of both units, with the Unit 3 steam generators exhibiting the larger amount of degradation in this area.

For the inspection of the overall condition of the eggcrates and ring in the stay cylinder,



a support plate inspection device was used. Little or no degradation was found in this area in either unit.

### 3. Summary of SONGS Unit 2 Eggcrate Inspection

The licensee's initial assessment of the Unit 2 steam generator eggcrate supports, conducted after the degradation issue was identified in the SONGS Unit 3 steam generators, was reported in its letter dated May 16, 1997. The licensee concluded that the Unit 2 eggcrate supports were in very good to excellent overall condition, based on the limited video examinations of the eggcrates performed in support of the chemical cleaning process. Although the licensee considered operation for the normal period of operation between refueling intervals to be acceptable on the basis of this limited examination, the licensee conservatively performed a more extensive video examination of the eggcrates during a mid-cycle outage that began on January 24, 1998. As reported in its March 10, 1998, letter, the licensee observed minor isolated instances of thinning in the periphery areas of the eggcrate supports, but overall the thinning was considerably less than that observed on SONGS Unit 3.

The NRC reviewed the program established by the licensee to conduct the video examinations of the eggcrate supports during the SONGS Unit 2 mid-cycle outage and reported its findings in Inspection Report 50-361/98-01; 50-362/98-01, dated May 29, 1998. This program was similar to the licensee's program for inspecting the Unit 3 eggcrate supports during its mid-cycle outage. The primary difference between the inspection programs for the two units was that a larger portion of the Unit 3 eggcrate structures was inspected. The staff concluded in its inspection report that the scope of the SONGS Unit 2 secondary side visual inspections was satisfactory and the results supportive of the licensee's conclusion that no steam generator tubes needed to be removed from service due to insufficient support from any secondary side support structures, which includes the eggcrate support structures.

#### 4. Actions Taken as a Result of Observed Eggcrate Degradation

Following the secondary side inspection activities conducted during the SONGS Unit 3 1997 refueling outage and 1998 mid-cycle outage, the licensee plugged and stabilized (by insertion of a steel cable inside the subject tube) some Unit 3 steam generator tubes as a precautionary measure due to the degradation observed in certain eggcrate supports. No tubes in the Unit 2 steam generators were removed from service. Once the tube is removed from service in the above described manner, support from the eggcrate structures is no longer needed. The criterion established by the licensee for removing tubes from service is described in detail below.

##### B. Concern About the Seismic Adequacy of the SONGS Steam Generators

The Petitioner asserts that the degradation of the steam generators, eggcrate supports could seriously weaken the supports and make the steam generators vulnerable to seismic events.

In its letter of May 16, 1997, the licensee committed to perform an evaluation of the effect of the degraded eggcrates on steam generator tube integrity in the SONGS Unit 3 steam generators before return to power from the Unit 3 1997 refueling outage. This initial evaluation was provided by the licensee in its letter of June 5, 1997, and included the effects of a postulated design-basis earthquake. The licensee submitted the final version of the degraded eggcrate support evaluation for SONGS Unit 3 on October 17, 1997. As stated in the previous section, the amount of eggcrate support degradation observed in SONGS Unit 2 was considerably less than that observed in Unit 3. Therefore, the staff concludes that demonstrating the ability of the SONGS Unit 3 steam generators to withstand a design basis seismic event will demonstrate the adequacy of the Unit 2 steam generators as well.

The staff's review of the seismic adequacy of the SONGS Unit 3 steam generators is

detailed below.

#### 1. Methodology and Acceptance Criteria

The Petitioner did not specifically request the staff to evaluate the eggcrate supports assuming other design loads concurrent with earthquake loads. However, to provide additional conservatism, and to conform with General Design Criterion (GDC) 2 of 10 CFR Part 50, Appendix A, the licensee, in its October 17, 1997, letter, evaluated the ability of the eggcrate supports to perform their intended safety function assuming the most limiting combination of load conditions.

GDC 2 requires, in part, that the design bases for structures, systems, and components important to safety reflect appropriate combinations of the effects of normal and accident conditions with the effects of natural phenomena such as earthquakes. The earthquake for which these plant features are designed is defined as the safe-shutdown earthquake (SSE).<sup>2</sup> The Petitioner's concerns on the adequacy of the seismic design of the SONGS units, based on information gathered from the Landers and Northridge earthquakes, were addressed previously by the staff in DD-97-23 (see footnote 1).

Appendix A of Standard Review Plan<sup>3</sup> (SRP) Section 3.9.3, "[American Society of Mechanical Engineers] ASME Code Class 1, 2, and 3 Components, Component Supports, and Core Support Structures," delineates acceptable design limits and appropriate combinations of

---

<sup>2</sup>The SSE is defined, in part, as "that earthquake which is based upon an evaluation of the maximum earthquake potential considering the regional and local geology and seismology and specific characteristics of local subsurface material. It is that earthquake which produces the maximum vibratory ground motion for which certain structures, systems, and components are designed to remain functional." See 10 CFR Part 100, Appendix A, Section III.(c).

<sup>3</sup>The Standard Review Plan (SRP) is published as NUREG-0800, and is used as guidance for the Office of Nuclear Reactor Regulation staff responsible for the review of applications to construct and operate nuclear power plants.

loadings associated with normal operation, postulated accidents, and specified seismic events for the design of Seismic Category I fluid system components (i.e., water- and steam-containing components). This appendix also provides that necessary plant features important to safety meet the appropriate design limits specified in Section III of the ASME Boiler and Pressure Vessel Code (ASME Code) when the component is subjected to concurrent loadings associated with the normal plant condition, the vibratory motion of the SSE, and the dynamic system loadings associated with the faulted plant condition. Faulted plant conditions are those operating conditions associated with postulated events of extremely low probability, such as loss-of-coolant accidents (LOCAs) or main steamline break (MSLB) accidents. The design limits and loading combinations utilized by the licensee in the October 17, 1997, evaluation of individual steam generator tubes are the same design limits and loading combinations that were reviewed and approved by the staff at the time of plant licensing. This evaluation is contained in Chapter 3 of NUREG-0712.<sup>4</sup> Therefore, the staff finds acceptable the licensee's use of these design limits and loading combinations in evaluating the impact of the degraded eggcrate supports on individual steam generator tubes.

The evaluation of the potential for lateral movement of the entire steam generator tube bundle (whole bundle evaluation) was not explicitly addressed during the staff's review performed at the time of plant licensing. Also, the ASME Code does not provide specific design limits for the whole bundle evaluation. The whole bundle evaluation contained in the October 17, 1997, letter was performed by the licensee to verify that the structural integrity of the eggcrate is maintained to ensure that it does not shift in a way that could damage the tubes. This is not an ASME Code evaluation; however, ASME Code techniques were used by the

---

<sup>4</sup>NUREG-0712, "Safety Evaluation Report related to the Operation of San Onofre Nuclear Generating Station, Units 2 and 3," Chapter 3, February 1981.

licensee to generate and assess the results. The staff has reviewed the specific ASME Code techniques utilized by the licensee, and concludes that they provide conservative results, and are, therefore, acceptable for the whole bundle evaluation.

Furthermore, the loading combinations used in the licensee's whole bundle evaluation are the same loading combinations used in the individual tube evaluations, and are the same loading combinations that were reviewed and approved at the time of plant licensing.

## 2. Degraded Eggcrate Support Assumptions

The staff reviewed the assumptions used in the licensee's October 17, 1997, evaluation regarding the amount of eggcrate support judged to be available, and verified that these assumptions were supported by the results of the licensee's inspections.

For the individual steam generator tube analysis, the licensee calculated the maximum loads that could occur assuming that adequate support was not available at two consecutive eggcrate levels (see Figure 1). The staff finds this assumption conservative and acceptable because the licensee has removed from service all tubes where two consecutive eggcrate levels were found degraded to the point where adequate support could not be assured.

For the whole bundle analysis, the licensee used the inspection results to sort the eggcrates into categories based on a conservative estimate of the remaining thickness of the eggcrate lattice bars. The staff reviewed the sorting criteria used by the licensee, and concludes that the material strength assumptions established by the licensee for the degraded eggcrate supports are conservative, and appropriate for evaluating the ability of the eggcrate structures to perform their intended function.

The visual inspections performed by the licensee during the 1998 mid-cycle outages for both units confirmed the appropriateness of these assumptions pertaining to the amount of eggcrate support degradation used in the licensee's evaluation.

### 3. Evaluation Results

Using the above described methodology and assumptions, the licensee determined that the peak calculated loads on the individual steam generator tubes would remain below the allowable design limits approved by NUREG-0712 during and following a postulated design basis earthquake.

The results of the licensee's whole bundle evaluation confirmed that the eggcrate structure will provide sufficient support to ensure that the tube bundle will not impact the eggcrate support ring during and following a postulated design basis earthquake.

The staff finds these results acceptable, and as detailed above, also finds acceptable the methodology and assumptions used by the licensee in the generation of these results. The staff concludes, therefore, that the amount of degradation observed in the eggcrate supports will not

prevent the SONGS Units 2 and 3 steam generators from performing their intended safety functions.<sup>5</sup>

#### 4. Confirmatory Actions

The licensee's 1998 mid-cycle inspection of the SONGS Unit 3 steam generators confirmed that the condition of the Unit 3 eggcrate internal supports remained within the analytical assumptions used in the licensee's evaluation contained in its October 17, 1997, letter and also supported the licensee's contention that the phenomenon (FAC) that led to the degradation of the eggcrates had been arrested by the chemical cleaning of the steam generators.

Furthermore, the licensee has committed in its letters to the NRC (April 15, 1998, for Unit 2 and October 17, 1997, for Unit 3) to inspect the eggcrate supports during future outages to assure that their condition remains within the analytical assumptions used in the licensee's evaluation. These inspections will continue to be conducted until it is established that further inspections are not required.

In summary, on the basis of the video inspection results for the steam generators in both units, and the staff's review of the detailed evaluations performed by the licensee, the staff concludes that the SONGS steam generators are fully capable of performing their intended safety function during and following a postulated SSE, and no retrofitting upgrade of the steam generators is required.

### III. CONCLUSION

---

<sup>5</sup>Since the amount of support degradation in SONGS Unit 2 was observed to be considerably less than that observed in Unit 3, the NRC staff concludes that the licensee's October 17, 1997, evaluation of SONGS Unit 3 steam generator structural integrity and the staff's review of that evaluation support the adequacy of SONGS Unit 2 steam generators to withstand a design basis event and perform their intended safety function.

As explained above, there is no evidence of significant degradation of the SONGS Unit 2 steam generator eggcrate supports, and the extensive analyses demonstrate the ability of the steam generators in both SONGS units to perform their intended safety function. Accordingly, the Petitioner's requested action, pursuant to Section 2.206, is denied.

A copy of this Decision will be filed with the Secretary of the Commission for the Commission to review in accordance with 10 CFR 2.206(c) of the Commission's regulations. As provided by this regulation, the Decision will constitute the final action of the Commission 25 days after issuance, unless the Commission, on its own motion, institutes a review of the Decision within that time.

FOR THE NUCLEAR REGULATORY COMMISSION

Original signed by

Samuel J. Collins, Director  
Office of Nuclear Reactor Regulation

Dated at Rockville, Maryland,  
this 11th day of June 1998

Attachments: Figures (3)



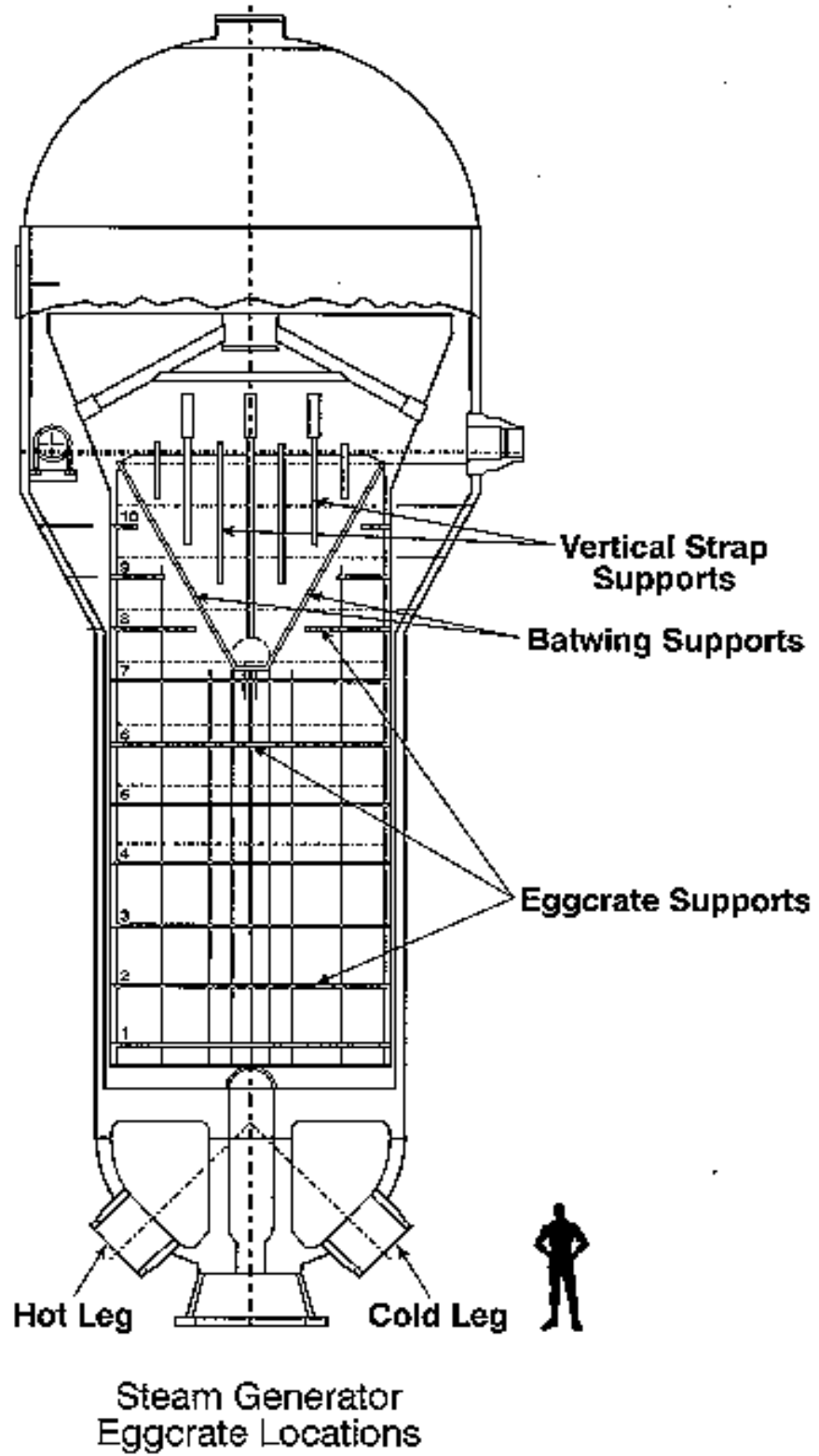
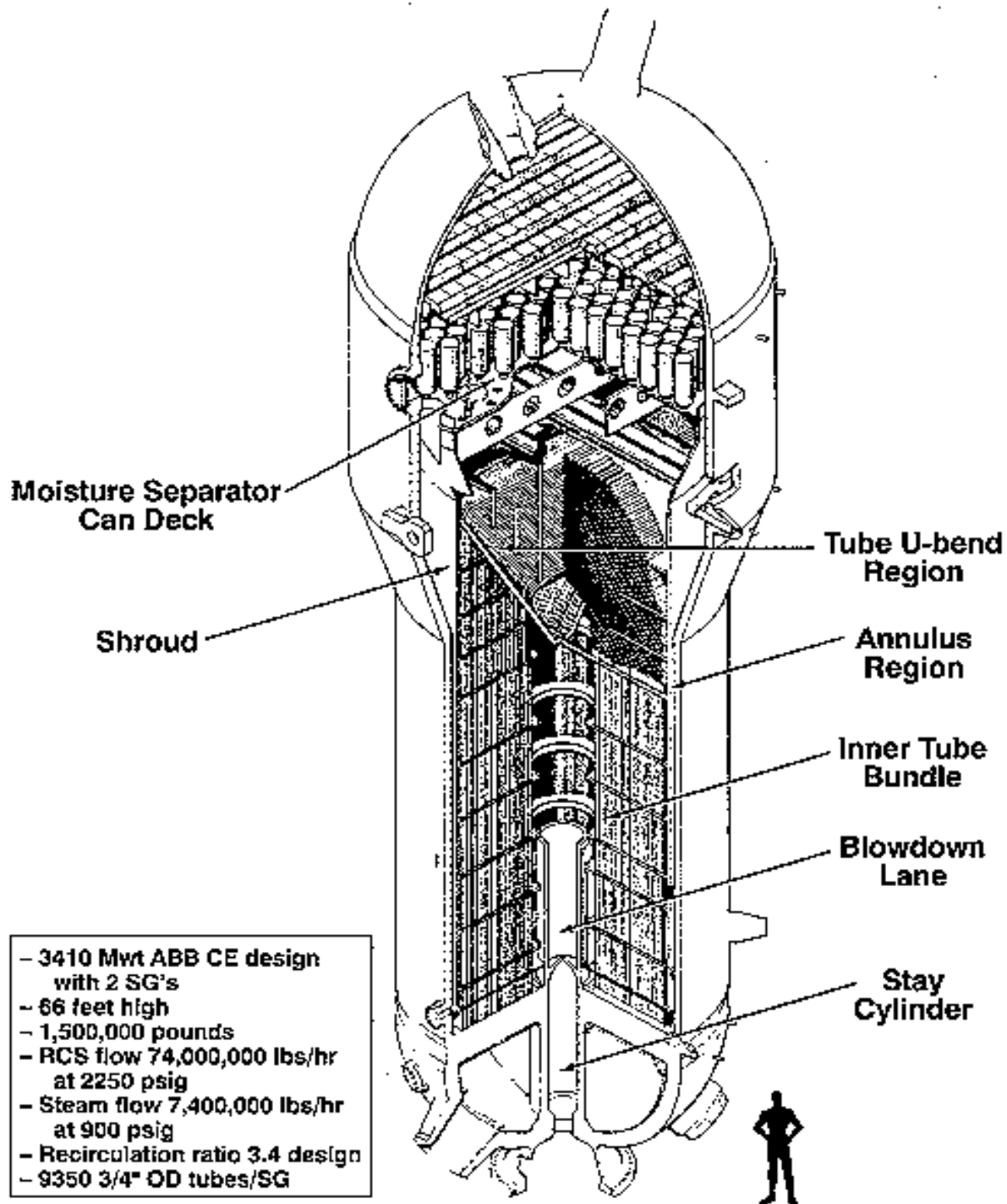
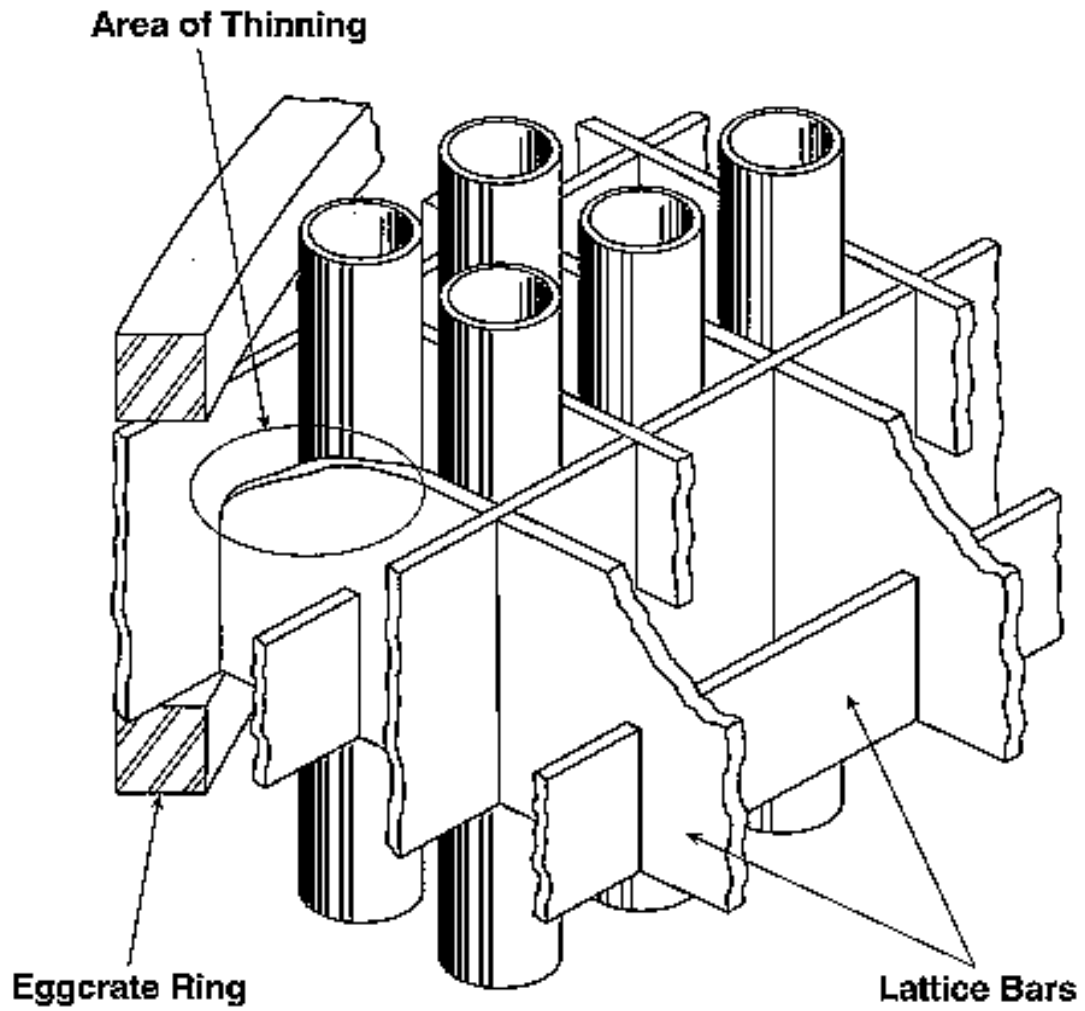

Figure 1



Typical CE Steam Generator

Figure 2



Eggcrate Arrangement

Figure 3

UNITED STATES NUCLEAR REGULATORY COMMISSION  
DOCKET NOS. 50-361 AND 50-362  
SOUTHERN CALIFORNIA EDISON COMPANY, ET AL.  
SAN ONOFRE NUCLEAR GENERATING STATION, UNITS 2 AND 3  
ISSUANCE OF DIRECTOR'S DECISION UNDER 10 CFR 2.206

Notice is hereby given that the Director, Office of Nuclear Reactor Regulation, has acted on a Petition for action under 10 CFR 2.206 received from Mr. Stephen Dwyer dated April 25, 1997, for the San Onofre Nuclear Generating Station (SONGS), Units 2 and 3.

The Petition requests that the Commission shut down the San Onofre Nuclear Generating Station pending a retrofitting of the steam generators. As a basis for the request, the Petitioner asserts that the ability of the steam generators to withstand a major seismic event is seriously compromised by the degraded eggcrate supports discovered in the SONGS Unit 3 steam generators.

The Director of the Office of Nuclear Reactor Regulation has determined that the request should be denied for the reasons stated in the "Director's Decision Under 10 CFR 2.206" (DD-98-06), the complete text of which follows this notice and which is available for public inspection at the Commission's Public Document Room, The Gelman Building, 2120 L

Street, N.W., Washington, D.C. 20555-0001, and at the Local Public Document Room located at the Main Library, University of California, P. O. Box 19557, Irvine, California 92713.

Dated at Rockville, Maryland, this 11th day of June 1998.

FOR THE NUCLEAR REGULATORY COMMISSION

Original signed by

Samuel J. Collins, Director  
Office of Nuclear Reactor Regulation