

TOPIC: 191007
KNOWLEDGE: K1.01 [2.3/2.5]
QID: P935 (B737)

A demineralizer is being used in a water purification system. How will the accumulation of suspended solids in the demineralizer affect the performance of the demineralizer?

- A. The rate of resin depletion will increase.
- B. The flow rate of water through the demineralizer will increase.
- C. The differential pressure across the demineralizer will decrease.
- D. The rate of unwanted ion removal from the system will decrease.

ANSWER: D.

TOPIC: 191007
KNOWLEDGE: K1.01 [2.3/2.5]
QID: P1035

A sudden increase in the conductivity of water at the outlet of a demineralizer may result from...

- A. increased demineralizer flow rate.
- B. reduced demineralizer inlet temperature.
- C. increased demineralizer effluent pressure.
- D. reduced demineralizer inlet conductivity.

ANSWER: A.

TOPIC: 191007
KNOWLEDGE: K1.01 [2.3/2.5]
QID: P2035 (B1237)

Which one of the following conditions can lead to channeling in an operating demineralizer?

- A. Suspended solids forming a mat on the surface layer of the resin bed.
- B. A sudden 10°F decrease in the temperature of the influent to the demineralizer.
- C. Exhaustion of the resin bed due to high conductivity of the demineralizer influent.
- D. Operation of the demineralizer with influent flow rate at 10 percent below design flow rate.

ANSWER: A.

TOPIC: 191007
KNOWLEDGE: K1.01 [2.3/2.5]
QID: P2135 (B637)

High differential pressure in a demineralizer could be caused by all of the following except...

- A. crud buildup.
- B. high flow rate.
- C. resin exhaustion.
- D. resin overheating.

ANSWER: C.

TOPIC: 191007
KNOWLEDGE: K1.03 [2.2/2.5]
QID: P535 (B39)

Which one of the following is an indication of resin exhaustion in a demineralizer?

- A. An increase in suspended solids in the effluent.
- B. A decrease in the flow rate through the demineralizer.
- C. An increase in the conductivity of the effluent.
- D. An increase in the differential pressure across the demineralizer.

ANSWER: C.

TOPIC: 191007
KNOWLEDGE: K1.03 [2.2/2.5]
QID: P835 (B839)

The decontamination factor for ionic impurities of a demineralizer can be expressed as...

- A. Inlet Conductivity minus Outlet Conductivity.
- B. Outlet Conductivity minus Inlet Conductivity.
- C. Inlet Conductivity divided by Outlet Conductivity.
- D. Outlet Conductivity divided by Inlet Conductivity.

ANSWER: C.

TOPIC: 191007
KNOWLEDGE: K1.03 [2.2/2.5]
QID: P936

The ion exchange efficiency of a condensate demineralizer is determined by performing a calculation using the...

- A. demineralizer inlet and outlet pH.
- B. demineralizer inlet and outlet conductivity.
- C. change in pH at the outlet of the demineralizer over a period of time.
- D. change in conductivity at the outlet of the demineralizer over a period of time.

ANSWER: B.

TOPIC: 191007
KNOWLEDGE: K1.03 [2.2/2.5]
QID: P1735

Which one of the following is an indication that a demineralizer resin has become exhausted?

- A. Decreased demineralizer process water flow rate.
- B. Decreased demineralizer influent conductivity.
- C. Decreased demineralizer differential pressure.
- D. Decreased demineralizer decontamination factor.

ANSWER: D.

TOPIC: 191007
KNOWLEDGE: K1.03 [2.2/2.5]
QID: P1835

The ion exchange efficiency of a condensate demineralizer can be calculated using the values for demineralizer inlet and outlet...

- A. conductivity.
- B. pH.
- C. N-16 radioactivity.
- D. pressure.

ANSWER: A.

TOPIC: 191007
KNOWLEDGE: K1.03 [2.2/2.5]
QID: P2236 (B1437)

To determine the decontamination factor for ionic impurities of a demineralizer, the two parameters that must be monitored are inlet and outlet...

- A. pH.
- B. conductivity.
- C. suspended solids.
- D. pressure.

ANSWER: B.

TOPIC: 191007
KNOWLEDGE: K1.03 [2.2/2.5]
QID: P2735 (B2737)

What percentage of impurities is being removed from the water passing through an ion exchanger if the ion exchanger has a decontamination factor of 25?

- A. 99 percent
- B. 96 percent
- C. 88 percent
- D. 75 percent

ANSWER: B.

TOPIC: 191007
KNOWLEDGE: K1.03 [2.2/2.5]
QID: P3235 (B3238)

What percentage of ionic impurities is being removed from the water passing through an ion exchanger if the ion exchanger has a decontamination factor of 50?

- A. 98 percent
- B. 96 percent
- C. 75 percent
- D. 50 percent

ANSWER: A.

TOPIC: 191007
KNOWLEDGE: K1.03 [2.2/2.5]
QID: P3435 (B3437)

The decontamination factor of a condensate demineralizer has just been determined to be 50, based on conductivity measurements.

If condensate having a conductivity of 20 $\mu\text{mho/cm}$ is flowing into this demineralizer, which one of the following is the conductivity of the condensate at the outlet of the demineralizer?

- A. 0.4 $\mu\text{mho/cm}$
- B. 1.0 $\mu\text{mho/cm}$
- C. 4.0 $\mu\text{mho/cm}$
- D. 10.0 $\mu\text{mho/cm}$

ANSWER: A.

TOPIC: 191007
KNOWLEDGE: K1.03 [2.2/2.5]
QID: P3636 (B3637)

The decontamination factor of a condensate demineralizer has just been determined to be 10, based on conductivity measurements.

If condensate having a conductivity of 20 $\mu\text{mho/cm}$ is flowing into this demineralizer, which one of the following is the conductivity of the condensate at the outlet of the demineralizer?

- A. 0.5 $\mu\text{mho/cm}$
- B. 2.0 $\mu\text{mho/cm}$
- C. 5.0 $\mu\text{mho/cm}$
- D. 10.0 $\mu\text{mho/cm}$

ANSWER: B.

TOPIC: 191007
KNOWLEDGE: K1.03 [2.2/2.5]
QID: P4219 (B4219)

The decontamination factor of a condensate demineralizer has just been determined to be 5.0, based on conductivity measurements.

If condensate having a conductivity of 20 $\mu\text{mho/cm}$ is flowing into this demineralizer, which one of the following is the conductivity of the condensate at the outlet of the demineralizer?

- A. 0.4 $\mu\text{mho/cm}$
- B. 4.0 $\mu\text{mho/cm}$
- C. 10.0 $\mu\text{mho/cm}$
- D. 100.0 $\mu\text{mho/cm}$

ANSWER: B.

TOPIC: 191007
KNOWLEDGE: K1.03 [2.2/2.5]
QID: P4718 (B4719)

What percentage of ionic impurities is being removed from the water passing through an ion exchanger if the ion exchanger has a decontamination factor of 1.0?

- A. 100 percent
- B. 99 percent
- C. 1 percent
- D. 0 percent

ANSWER: D.

TOPIC: 191007
KNOWLEDGE: K1.03 [2.2/2.5]
KNOWLEDGE: K1.06 [2.1/2.5]
QID: P5418

Two indications of channeling through an operating demineralizer are a _____-than-normal demineralizer differential pressure and a _____-than-normal decontamination factor for ionic impurities.

- A. higher; lower
- B. higher; higher
- C. lower; lower
- D. lower; higher

ANSWER: C.

TOPIC: 191007
KNOWLEDGE: K1.05 [2.0/2.2]
QID: P7746 (B7746)

Mixed-bed demineralizer 1A was removed from service after it became saturated with sodium (Na^+) ions while processing condensate with 10 times the normal sodium concentration. Alternate mixed-bed demineralizer 1B has restored the condensate sodium concentration to normal. Demineralizer 1A has not been processed in any way since being removed from service.

If demineralizer 1A is returned to service to replace demineralizer 1B, the downstream condensate system sodium concentration will...

- A. remain the same, because demineralizer 1A can no longer remove any anions from the condensate.
- B. remain the same, because demineralizer 1A can no longer remove any cations from the condensate.
- C. increase, only due to the water volume contained in demineralizer 1A mixing with the condensate influent.
- D. increase, due to both the water volume contained in demineralizer 1A mixing with the condensate influent and the release of sodium ions from the resin.

ANSWER: D.

TOPIC: 191007
KNOWLEDGE: K1.05 [2.0/2.2]
QID: P7756 (B7756)

If water containing negatively charged ionic impurities passes through a mixed-bed ion exchanger, the negatively charged ionic impurities will be removed by the _____ exchange resin, with the corresponding release of _____ ions into the water.

- A. anion; negative
- B. anion; positive
- C. cation; negative
- D. cation; positive

ANSWER: A.

TOPIC: 191007
KNOWLEDGE: K1.06 [2.1/2.5]
QID: P635 (B2237)

How does demineralizer differential pressure indicate the condition of a demineralizer resin bed?

- A. Low differential pressure indicates flow blockage in the demineralizer.
- B. Low differential pressure indicates that the demineralizer resin bed is exhausted.
- C. High differential pressure indicates flow blockage in the demineralizer.
- D. High differential pressure indicates that the demineralizer resin bed is exhausted.

ANSWER: C.

TOPIC: 191007
KNOWLEDGE: K1.06 [2.1/2.5]
QID: P836 (B539)

A lower-than-expected differential pressure across a mixed-bed demineralizer is an indication of...

- A. depletion of the resin.
- B. channeling through the resin bed.
- C. improper resin regeneration.
- D. a decrease in inlet conductivity.

ANSWER: B.

TOPIC: 191007
KNOWLEDGE: K1.06 [2.1/2.5]
QID: P1036 (B639)

As the operating time of a demineralizer resin bed increases, the differential pressure across the bed...

- A. increases due to depletion of the resin ion exchange sites.
- B. increases due to trapping of suspended solids.
- C. decreases due to gradual resin breakdown.
- D. decreases due to erosion of the resin ion exchange sites.

ANSWER: B.

TOPIC: 191007
KNOWLEDGE: K1.06 [2.1/2.5]
QID: P1136

Which one of the following will cause a large pressure drop across a demineralizer that is in operation?

- A. Channeling of flow through the demineralizer.
- B. Decrease in flow rate through the demineralizer.
- C. Accumulation of suspended solids filtered by the resin beads.
- D. Improper demineralizer venting after resin fill.

ANSWER: C.

TOPIC: 191007
KNOWLEDGE: K1.06 [2.1/2.5]
QID: P1236

An indication that a demineralizer resin bed is clogged is a...

- A. large pressure drop across the bed.
- B. high flow rate through the bed.
- C. temperature rise in the effluent.
- D. large conductivity increase across the bed.

ANSWER: A.

TOPIC: 191007
KNOWLEDGE: K1.06 [2.1/2.5]
QID: P1535 (B1138)

A condensate demineralizer differential pressure (D/P) gauge indicates 4.0 psid at 50 percent flow rate. Over the next two days plant power changes have caused condensate flow rate to vary between 25 and 100 percent.

Which one of the following combinations of condensate flow rate and demineralizer D/P, observed during the power changes, indicates an increase in the accumulation of insoluble corrosion products in the demineralizer?

	<u>Condensate Flow Rate (%)</u>	<u>Demineralizer D/P (psid)</u>
A.	100%	15.0
B.	75%	9.0
C.	60%	5.0
D.	25%	2.0

ANSWER: D.

TOPIC: 191007
KNOWLEDGE: K1.06 [2.1/2.5]
QID: P1537 (B1539)

A higher-than-expected differential pressure across an operating demineralizer can be caused by...

- A. exhaustion of the cation exchange resin.
- B. channeling through the resin bed.
- C. insufficient resin backwash.
- D. decreased demineralizer inlet conductivity.

ANSWER: C.

TOPIC: 191007
KNOWLEDGE: K1.06 [2.1/2.5]
QID: P1736 (B1736)

A condensate demineralizer differential pressure (D/P) gauge indicates 6.0 psid at 50% flow rate. Which one of the following combinations of condensate flow rate and demineralizer D/P observed at various power levels over the next few days indicates an increase in the accumulation of insoluble corrosion products in the demineralizer?

	<u>Condensate Flow Rate</u>	<u>Demineralizer D/P (psid)</u>
A.	100%	23.5
B.	75%	16.5
C.	60%	8.5
D.	25%	1.5

ANSWER: B.

TOPIC: 191007
KNOWLEDGE: K1.06 [2.1/2.5]
QID: P1836 (B337)

A fresh demineralizer that continuously processes water with a high concentration of suspended solids will first develop an increase in the...

- A. conductivity at the demineralizer outlet.
- B. decontamination factor of the demineralizer.
- C. differential pressure across the demineralizer.
- D. pH at the demineralizer outlet.

ANSWER: C.

TOPIC: 191007
KNOWLEDGE: K1.06 [2.1/2.5]
QID: P2235 (B2638)

A condensate demineralizer differential pressure (D/P) gauge indicates 4.0 psid at 50% flow rate. Which one of the following combinations of condensate flow and demineralizer D/P observed at various power levels over the next few days indicates an increase in the accumulation of insoluble corrosion products in the demineralizer?

	<u>Condensate Flow Rate</u>	<u>Demineralizer D/P (psid)</u>
A.	25%	0.9
B.	60%	6.3
C.	75%	8.7
D.	100%	15.6

ANSWER: B.

TOPIC: 191007
KNOWLEDGE: K1.06 [2.1/2.5]
QID: P2335 (B2338)

A condensate demineralizer differential pressure (D/P) gauge indicates 4.0 psid at 50% flow rate. Over the next two days plant power changes have caused condensate flow rate to vary between 25% and 100%.

Which one of the following combinations of condensate flow and demineralizer D/P, observed during the power changes, indicates an increase in the accumulation of insoluble corrosion products in the demineralizer?

	<u>Condensate Flow Rate</u>	<u>Demineralizer D/P (psid)</u>
A.	100%	15.0
B.	75%	9.0
C.	40%	3.0
D.	25%	1.0

ANSWER: C.

TOPIC: 191007
KNOWLEDGE: K1.06 [2.1/2.5]
QID: P7645 (B7645)

Which one of the following describes a possible cause and effect associated with a lower-than-normal differential pressure across a demineralizer during otherwise normal system flow conditions?

- A. The resin has developed low resistance flow paths, which can decrease the decontamination factor for the demineralizer.
- B. The resin has developed low resistance flow paths, which can increase the decontamination factor for the demineralizer.
- C. The resin has become compacted, which can reduce the flow rate through the demineralizer and decrease the decontamination factor for the demineralizer.
- D. The resin has become compacted, which can reduce the flow rate through the demineralizer and increase the decontamination factor for the demineralizer.

ANSWER: A.

TOPIC: 191007
KNOWLEDGE: K1.08 [3.0/3.1]
QID: P1636 (B838)

Which one of the following, if processed through a demineralizer, will rapidly reduce the effectiveness of the demineralizer?

- A. Oily water
- B. Condensate
- C. Makeup water
- D. Radioactive water

ANSWER: A.

TOPIC: 191007
KNOWLEDGE: K1.08 [3.0/3.1]
QID: P2037

A nuclear power plant has been operating normally at 100 percent power for one month and with the same reactor coolant boron concentration for the last 24 hours.

Which one of the following changes associated with the in-service reactor coolant demineralizer will reduce the reactor coolant boron concentration in the demineralizer effluent?

- A. Increase the temperature of the reactor coolant being processed from 95°F to 105°F.
- B. Decrease the temperature of the reactor coolant being processed from 105°F to 95°F.
- C. Increase the flow rate of reactor coolant being processed from 75 gpm to 100 gpm.
- D. Decrease the flow rate of reactor coolant being processed from 75 gpm to 50 gpm.

ANSWER: B.

TOPIC: 191007
KNOWLEDGE: K1.08 [3.0/3.1]
QID: P2837

A nuclear power plant has two identical mixed resin reactor coolant ion exchangers, A and B, which operated in parallel service continuously for two weeks of power operation immediately after a refueling outage. Ion exchanger A was then removed from service while ion exchanger B remained in service. After 10 months of continuous operation at full power, it is necessary to place ion exchanger A in service and remove ion exchanger B from service.

Which one of the following describes why the effluent from ion exchanger A initially should be drained to a collection facility prior to placing the ion exchanger in full service?

- A. To prevent a rapid increase in reactor coolant pH.
- B. To prevent a rapid decrease in reactor coolant pH.
- C. To prevent a rapid increase in reactor coolant boron concentration.
- D. To prevent a rapid decrease in reactor coolant boron concentration.

ANSWER: C.

TOPIC: 191007
KNOWLEDGE: K1.08 [3.0/3.1]
QID: P2937

A nuclear power plant has been operating at steady-state 100 percent power for one month, and with the same reactor coolant boron concentration for the last 24 hours.

Which one of the following changes associated with an in-service reactor coolant letdown ion exchanger will increase the reactor coolant boron concentration in the ion exchanger effluent?

- A. Increase the temperature of the reactor coolant being processed from 95°F to 105°F.
- B. Decrease the temperature of the reactor coolant being processed from 105°F to 95°F.
- C. Increase the flow rate of reactor coolant being processed from 75 gpm to 100 gpm.
- D. Decrease the flow rate of reactor coolant being processed from 75 gpm to 50 gpm.

ANSWER: A.

TOPIC: 191007
KNOWLEDGE: K1.08 [3.0/3.1]
QID: P5719

A mixed-bed ion exchanger is being used to process reactor coolant letdown. The ion exchanger is boron-saturated for the existing reactor coolant conditions.

If reactor coolant letdown temperature decreases by 20°F, the total number of boron atoms occupying the ion exchange sites will _____; and the boron concentration in the ion exchanger effluent will _____.

- A. increase; decrease
- B. increase; increase
- C. decrease; decrease
- D. decrease; increase

ANSWER: A.

TOPIC: 191007
KNOWLEDGE: K1.08 [3.2/3.1]
QID: P6018

A mixed-bed ion exchanger is being used to process reactor coolant letdown. The ion exchanger is boron-saturated for the existing reactor coolant conditions. Which one of the following describes a system change and resulting effect that will cause the boron concentration in the ion exchanger outlet water to be greater than the boron concentration in the inlet water?

- A. An increase in reactor coolant ionic impurities with higher relative affinities for the resin exchange sites will displace borate ions from the resin exchange sites.
- B. An increase in reactor coolant suspended solids with greater mass than the borate ions will mechanically remove borate ions from the resin exchange sites.
- C. A decrease in the temperature of the inlet water will lower the relative affinity of the resin for the borate ions, which releases borate ions from the resin exchange sites.
- D. A decrease in the flow rate through the ion exchanger will lower the retention capacity of the resin, which releases borate ions from the resin exchange sites.

ANSWER: A.

TOPIC: 191007
KNOWLEDGE: K1.08 [3.0/3.1]
QID: P6318

A mixed-bed ion exchanger is being used to process reactor coolant letdown. The ion exchanger is boron-saturated for the existing reactor coolant conditions.

Reactor coolant letdown temperature at the inlet to the ion exchanger increases by 15°F, while remaining within the normal temperature range. Because of the temperature increase, the total number of boron atoms occupying the ion exchange sites will _____; and the boron concentration in the ion exchanger effluent will _____.

- A. increase; decrease
- B. increase; increase
- C. decrease; decrease
- D. decrease; increase

ANSWER: D.

TOPIC: 191007
KNOWLEDGE: K1.08 [3.2/3.1]
QID: P7018

Reactor coolant system (RCS) purification mixed-bed ion exchanger A was removed from service and isolated after several weeks of operation with an RCS boron concentration of 900 ppm. After it was isolated, ion exchanger A was not processed in any way.

Currently, the RCS boron concentration is 450 ppm. If ion exchanger A is returned to service, the RCS boron concentration will...

- A. remain the same because the resin in ion exchanger A has already become saturated with boron during previous operation.
- B. remain the same because the resin in ion exchanger A has no affinity for the boron in the reactor coolant.
- C. increase until the volume of water in ion exchanger A mixes completely with the RCS.
- D. increase until the resin in ion exchanger A reaches equilibrium with the existing RCS boron concentration.

ANSWER: D.

TOPIC: 191007
KNOWLEDGE: K1.08 [3.2/3.1]
QID: P7218

A mixed-bed ion exchanger is being used to process reactor coolant letdown. The ion exchanger is boron-saturated for the existing reactor coolant conditions. Which one of the following describes a system change and resulting effect that will cause the boron concentration in the ion exchanger outlet water to be greater than the boron concentration in the inlet water?

- A. An increase in the flow rate through the ion exchanger will lower the retention capacity of the resin, which releases borate ions from the resin exchange sites.
- B. An increase in reactor coolant suspended solids with greater mass than the borate ions will mechanically remove borate ions from the resin exchange sites.
- C. A decrease in the temperature of the inlet water will lower the relative affinity of the resin for the borate ions, which releases borate ions from the resin exchange sites.
- D. A decrease in reactor coolant boron concentration will cause captured borate ions to be released to re-establish chemical equilibrium at the resin exchange sites.

ANSWER: D.

TOPIC: 191007
KNOWLEDGE: K1.08 [3.2/3.1]
QID: P7795

Reactor coolant system (RCS) mixed-bed ion exchanger 1A was removed from service after several months of operation with an RCS boron concentration of 550 ppm. Alternate mixed-bed ion exchanger 1B is currently in service with an RCS boron concentration of 400 ppm.

Ion exchanger 1A was drained and refilled with reactor coolant having a boron concentration of 400 ppm in preparation for being returned to service to replace ion exchanger 1B.

When ion exchanger 1A is returned to service, its effluent boron concentration initially will be _____ than its influent boron concentration because _____.

- A. lower; ion exchanger 1A will continue to remove boron atoms from the reactor coolant as it flows through the ion exchanger.
- B. higher; some of the previously-captured boron atoms will be released as the reactor coolant flows through ion exchanger 1A.
- C. the same; for each boron atom removed from the reactor coolant by ion exchanger 1A, one boron atom will be released.
- D. the same; ion exchanger 1A is boron-saturated and cannot remove additional boron atoms from the reactor coolant.

ANSWER: B.

TOPIC: 191007
KNOWLEDGE: K1.08 [3.2/3.1]
QID: P7806

Refer to the drawing of an operating reactor coolant system (RCS) purification system with a mixed-bed ion exchanger (see figure below).

Initially, a nuclear power plant is operating at 100 percent power in the middle of a fuel cycle with reactor coolant flowing through the purification system at 120 gpm. Then, valve C is repositioned to reduce the reactor coolant flow rate to 60 gpm.

If no other valves are repositioned, the boron concentration of the reactor coolant returning to the RCS will...

- A. increase, because the ion exchanger is less effective at removing boron atoms from the reactor coolant at higher reactor coolant temperatures.
- B. increase, because the ion exchanger is less effective at removing boron atoms from the reactor coolant at lower reactor coolant temperatures.
- C. decrease, because the ion exchanger is more effective at removing boron atoms from the reactor coolant at higher reactor coolant temperatures.
- D. decrease, because the ion exchanger is more effective at removing boron atoms from the reactor coolant at lower reactor coolant temperatures.

ANSWER: D.

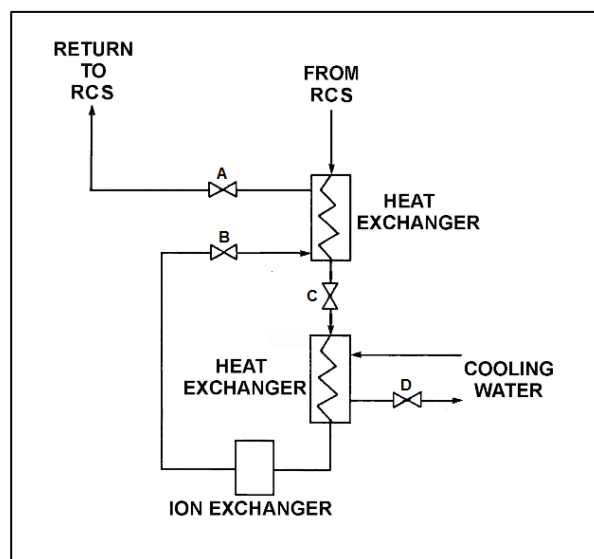

TOPIC: 191007
KNOWLEDGE: K1.08 [3.2/3.1]
QID: P7825

Reactor coolant letdown is aligned with observable flow through a mixed-bed ion exchanger. If the temperature of the reactor coolant letdown decreases from 110°F to 90°F, the boron concentration in the ion exchanger effluent will _____; primarily due to the change in boron-removal effectiveness of the _____ exchange resin.

- A. increase; anion
- B. increase; cation
- C. decrease; anion
- D. decrease; cation

ANSWER: C.

TOPIC: 191007
KNOWLEDGE: K1.09 [2.5/2.7]
QID: P34

What is the reason for bypassing a demineralizer due to high temperature?

- A. Resins expand and restrict flow through the demineralizer.
- B. Resins decompose and restrict flow through the demineralizer.
- C. Resins decompose and create preferential flowpaths through the demineralizer.
- D. Resins decompose and release resin particles into the flow.

ANSWER: D.

TOPIC: 191007
KNOWLEDGE: K1.09 [2.5/2.7]
QID: P235 (B1838)

When a mixed-bed demineralizer resin is exhausted, the resin should be replaced or regenerated because...

- A. ions previously removed by the resin will be released into solution.
- B. the resin will fracture and particles may escape through the retention screens.
- C. particles previously filtered out of solution will be released.
- D. the resin will physically bond together, thereby causing flow blockage.

ANSWER: A.

TOPIC: 191007
KNOWLEDGE: K1.09 [2.5/2.7]
QID: P236

A demineralizer that has been exposed to excessively _____ should be bypassed because the resin beads may release previously removed ions.

- A. high flow rate
- B. low flow rate
- C. high temperature
- D. low temperature

ANSWER: C.

TOPIC: 191007
KNOWLEDGE: K1.09 [2.5/2.7]
QID: P2637 (B239)

A result of proper demineralizer operation on water with ionic impurities is that the exiting water will always have a...

- A. higher pH.
- B. lower pH.
- C. higher conductivity.
- D. lower conductivity.

ANSWER: D.

TOPIC: 191007
KNOWLEDGE: K1.09 [2.5/2.7]
QID: P7606 (B7606)

A mixed-bed ion exchanger is being used to process reactor coolant. The ion exchanger has been in service for 6 months at 100 percent power. A temperature controller malfunction causes the ion exchanger influent temperature to exceed the resin's maximum temperature limit before being manually restored to normal. Ion exchanger water chemistry analyses are being performed to check for resin decomposition.

Which one of the following water chemistry test results does not indicate that significant resin decomposition has occurred?

- A. A significant decrease in the ion exchanger's decontaminator factor.
- B. A significant increase in the ion exchanger's effluent conductivity.
- C. A significant increase in the ion exchanger's effluent radioactivity.
- D. A significant increase in the ion exchanger's effluent dissolved gases.

ANSWER: D.

TOPIC: 191007
KNOWLEDGE: K1.09 [2.5/2.7]
QID: P7656 (B7656)

Demineralizer 1A was removed from service after it became saturated with chloride ions while processing condensate with 10 times the normal chloride concentration. Replacement demineralizer 1B has restored the condensate chloride concentration to normal. Demineralizer 1A has not been processed in any way since being removed from service.

If demineralizer 1A is returned to service to replace demineralizer 1B, the downstream condensate system chloride concentration will...

- A. remain the same, because demineralizer 1A resin has already been conditioned by previous operation.
- B. remain the same, because demineralizer 1A resin can no longer remove chloride ions from the condensate.
- C. increase, only due to the volume of water contained in demineralizer 1A mixing with the incoming condensate.
- D. increase, due to both the volume of water contained in demineralizer 1A mixing with the incoming condensate and the release of chloride ions from the resin.

ANSWER: D.

TOPIC: 191007
KNOWLEDGE: K1.09 [2.5/2.7]
QID: P7685 (B7685)

A mixed-bed ion exchanger is being used to process reactor coolant. The ion exchanger has been in service for 6 months at 100 percent power. A temperature controller malfunction causes the ion exchanger influent temperature to exceed the resin's maximum temperature limit before being manually restored to normal. Ion exchanger water chemistry analyses are being performed to check for resin decomposition.

Which one of the following water chemistry test results would indicate that significant resin decomposition has occurred?

- A. A significant decrease in the ion exchanger's effluent conductivity.
- B. A significant increase in the ion exchanger's effluent radioactivity.
- C. A significant increase in the ion exchanger's decontamination factor.
- D. A significant increase in the ion exchanger's effluent dissolved gases.

ANSWER: B.

TOPIC: 191007
KNOWLEDGE: K1.09 [2.5/2.7]
QID: P7715 (B7715)

A demineralizer should be removed from service if the demineralizer differential pressure is _____ than the established limit, or if the demineralizer decontamination factor is _____ than the established limit.

- A. less; less
- B. less; greater
- C. greater; less
- D. greater; greater

ANSWER: C.

TOPIC: 191007
KNOWLEDGE: K1.11 [2.5/2.8]
QID: P336

Prior to a scheduled nuclear power plant shutdown, the reactor coolant system was chemically shocked to induce a crud burst. What effect will the crud burst have on the reactor coolant letdown ion exchangers?

- A. Decreased radiation levels around the ion exchangers.
- B. Increased flow rate through the ion exchangers.
- C. Decreased ion exchanger outlet conductivity.
- D. Increased pressure drop across the ion exchangers.

ANSWER: D.

TOPIC: 191007
KNOWLEDGE: K1.11 [2.5/2.8]
QID: P1436

Prior to a scheduled nuclear power plant shutdown, the reactor coolant system was chemically shocked to induce a crud burst. What effect will the crud burst have on the in-service reactor coolant letdown ion exchangers?

- A. Decreased ion exchanger outlet conductivity.
- B. Decreased pressure drop across the ion exchangers.
- C. Increased flow rate through the ion exchangers.
- D. Increased radiation levels around the ion exchangers.

ANSWER: D.

TOPIC: 191007
KNOWLEDGE: K1.11 [2.5/2.8]
QID: P2736

A nuclear power plant was operating at steady-state 100 percent power when the reactor coolant system experienced a large crud burst. After 20 minutes, the operators begin to record parameters for the in-service reactor coolant purification ion exchanger.

Assuming no additional operator actions, what trend will the recorded parameters show during the next few hours?

- A. Increasing flow rate through the ion exchanger.
- B. Increasing pressure drop across the ion exchanger.
- C. Increasing ion exchanger inlet water conductivity.
- D. Increasing ion exchanger outlet water conductivity.

ANSWER: B.

TOPIC: 191007
KNOWLEDGE: K1.11 [2.5/2.8]
QID: P3537 (B6320)

After 12 months of operation at 100 percent power, a reactor was shut down and a plant cooldown is in progress. An operator reports that the general area radiation level near the in-service reactor coolant ion exchanger has increased significantly since the cooldown began several hours ago.

Which one of the following is a typical cause of these indications, resulting from the cooldown?

- A. Increased radioactive tritium in the reactor coolant.
- B. Increased radioactive oxygen-16 dissolved in the reactor coolant.
- C. Increased radioactive nitrogen-16 dissolved in the reactor coolant.
- D. Increased radioactive corrosion products suspended in the reactor coolant.

ANSWER: D.

TOPIC: 191007
KNOWLEDGE: K1.11 [2.5/2.8]
QID: P5819 (B5820)

During a nuclear power plant cooldown, the reactor experiences a large crud burst. After 10 minutes, with stable reactor coolant chemistry parameters, the operators begin to record parameters for the in-service reactor coolant purification ion exchanger. The ion exchanger was recently filled with fresh resin.

Assuming no additional operator actions, what trend will the recorded parameters show during the next few hours?

- A. Increasing ion exchanger inlet water conductivity.
- B. Increasing ion exchanger outlet water conductivity.
- C. Increasing flow rate through the ion exchanger.
- D. Increasing radiation levels around the ion exchanger.

ANSWER: D.

TOPIC: 191007
KNOWLEDGE: K1.14 [2.4/2.6]
QID: P337

A nuclear power plant is operating at 70 percent steady-state power level when the temperature of the reactor coolant letdown passing through a boron-saturated mixed-bed ion exchanger decreases by 20°F.

As a result, the boron concentration in the effluent of the ion exchanger will _____ because the ability of the ion exchanger to remove boron atoms has _____.

- A. decrease; increased
- B. decrease; decreased
- C. increase; increased
- D. increase; decreased

ANSWER: A.

TOPIC: 191007
KNOWLEDGE: K1.14 [2.4/2.6]
QID: P1335

A nuclear power plant is operating at steady-state 70 percent power when the temperature of the reactor coolant letdown passing through a boron-saturated mixed-bed ion exchanger increases by 20°F.

As a result, the boron concentration in the effluent of the ion exchanger will _____ because the ability of the ion exchanger to remove boron atoms has _____.

- A. decrease; decreased
- B. decrease; increased
- C. increase; decreased
- D. increase; increased

ANSWER: C.

TOPIC: 191007
KNOWLEDGE: K1.14 [2.4/2.6]
QID: P3337

Which one of the following indicates that a demineralizer receiving 75 gpm of reactor coolant is boron-saturated?

- A. The decontamination factor of the demineralizer is less than 1.0.
- B. The decontamination factor of the demineralizer is greater than 1.0.
- C. After a demineralizer inlet temperature increase, demineralizer effluent boron concentration exceeds influent boron concentration.
- D. After a demineralizer inlet temperature increase, demineralizer influent boron concentration exceeds effluent boron concentration.

ANSWER: C.