

TOPIC: 293008
KNOWLEDGE: K1.01 [2.6/2.8]
QID: B88

The highest rate of heat transfer from the fuel rod surface to the coolant is provided by...

- A. forced convection with subcooled coolant (no boiling).
- B. natural convection with subcooled coolant (no boiling).
- C. natural convection with bulk boiling of coolant.
- D. forced convection with nucleate boiling.

ANSWER: D.

TOPIC: 293008
KNOWLEDGE: K1.01 [2.6/2.8]
QID: B89

The order of heat transfer modes for coolant flowing through a fuel bundle is...

- A. nucleate boiling, single-phase convection, slug flow, annular flow.
- B. nucleate boiling, single-phase convection, annular flow, slug flow.
- C. single-phase convection, nucleate boiling, slug flow, annular flow.
- D. single-phase convection, nucleate boiling, annular flow, slug flow.

ANSWER: C.

TOPIC: 293008
KNOWLEDGE: K1.01 [2.6/2.8]
QID: B389 (P286)

Which one of the following characteristics will enhance steam bubble formation in water adjacent to a heated surface?

- A. Chemicals dissolved in the water.
- B. The absence of ionizing radiation exposure to the water.
- C. A highly polished heat transfer surface with minimal scratches or cavities.
- D. The presence of gases dissolved in the water.

ANSWER: D.

TOPIC: 293008
KNOWLEDGE: K1.01 [2.6/2.8]
QID: B885

The dominant mode of heat transfer that occurs when nucleate boiling is present is...

- A. convection.
- B. radiation.
- C. conduction.
- D. induction.

ANSWER: A.

TOPIC: 293008
KNOWLEDGE: K1.01 [2.6/2.8]
QID: B986

Which one of the following describes convection heat transfer?

- A. The flow of heat through a body or between bodies in direct contact.
- B. The flow of heat between two different fluids not in direct contact.
- C. The flow of heat from a body by electromagnetic waves across an intervening space.
- D. The flow of heat between a fluid and surface by circulation of the fluid.

ANSWER: D.

TOPIC: 293008
KNOWLEDGE: K1.01 [2.6/2.8]
QID: B1183

Refer to the drawing of a pool boiling curve (see figure below). In which region(s) of the curve does a reactor normally operate to transfer heat from the fuel cladding to the coolant at 100 percent power?

- A. Regions II and III
- B. Region II only
- C. Regions I and II
- D. Region I only

ANSWER: C.

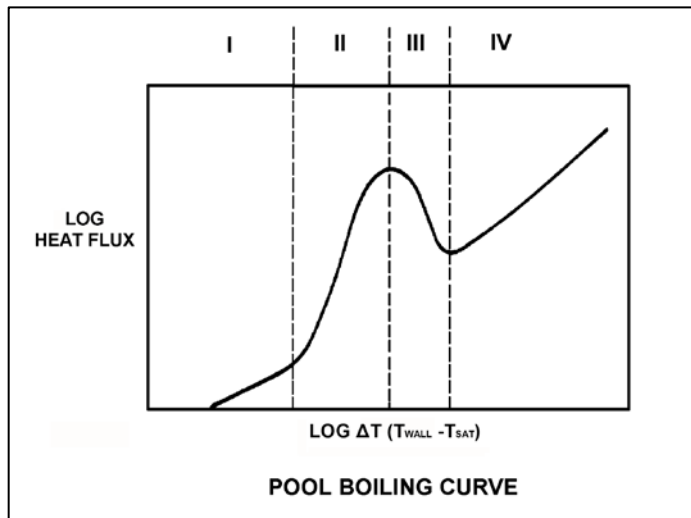

TOPIC: 293008
KNOWLEDGE: K1.01 [2.6/2.8]
QID: B1285 (P2787)

Which one of the following characteristics will enhance steam bubble formation in the coolant adjacent to a fuel rod?

- A. Surface scratches or cavities in the fuel cladding.
- B. Subsurface void defect in the fuel cladding.
- C. Increased coolant velocity past the fuel rod.
- D. Chemically inert material dissolved in the coolant.

ANSWER: A.

TOPIC: 293008
KNOWLEDGE: K1.01 [2.6/2.8]
QID: B2784 (P1086)

How does the convective heat transfer coefficient vary from the bottom to the top of a fuel assembly if reactor coolant enters the fuel assembly as subcooled water and exits as superheated steam?

- A. Increases continuously.
- B. Increases, then decreases.
- C. Decreases continuously.
- D. Decreases, then increases.

ANSWER: B.

TOPIC: 293008
KNOWLEDGE: K1.04 [2.6/2.7]
QID: B90

Boiling improves heat transfer because the...

- A. agitation produced reduces the thickness of the fluid film, and the bubble formation removes the latent heat of vaporization from the heated surface.
- B. bubbles produced reduce the turbulence in the bulk fluid flow and transfer the latent heat of condensation to the fluid as the steam bubbles collapse in the laminar fluid film.
- C. velocity of the laminar fluid film past the heated surface increases causing the ΔT between the heated surface and the fluid film to increase.
- D. velocity of the laminar fluid film near the heated surface decreases, causing the liquid contact time with the heated surface to increase.

ANSWER: A.

TOPIC: 293008
KNOWLEDGE: K1.04 [2.6/2.7]
QID: B486

Nucleate boiling occurring at the surface of a fuel rod...

- A. increases the convective heat transfer from the fuel rod to the coolant.
- B. decreases the convective heat transfer from the fuel rod to the coolant.
- C. has no effect on convective heat transfer because it is boiling heat transfer.
- D. causes damage to the fuel rod because it disrupts the laminar flow of coolant next to the fuel rod.

ANSWER: A.

TOPIC: 293008
KNOWLEDGE: K1.04 [2.6/2.7]
QID: B588 (P389)

Core heat transfer rate is maximized by the presence of...

- A. laminar flow with no nucleate boiling.
- B. turbulent flow with no nucleate boiling.
- C. laminar flow with nucleate boiling.
- D. turbulent flow with nucleate boiling.

ANSWER: D.

TOPIC: 293008
KNOWLEDGE: K1.04 [2.6/2.7]
QID: B1086 (P2287)

Which one of the following describes a reason for the increased heat transfer rate that occurs when nucleate boiling begins on the surface of a fuel rod?

- A. Steam bubbles have a greater thermal conductivity than water.
- B. The formation of steam bubbles increases coolant flow along the fuel rod.
- C. Radiative heat transfer begins to supplement convective heat transfer.
- D. The motion of the steam bubbles causes rapid mixing of the coolant.

ANSWER: D.

TOPIC: 293008
KNOWLEDGE: K1.04 [2.6/2.7]
QID: B1890 (P487)

Nucleate boiling enhances the convective heat transfer coefficient by _____ the thermal conductivity of the coolant and _____ the laminar layer thickness.

- A. increasing; decreasing
- B. increasing; increasing
- C. decreasing; decreasing
- D. decreasing; increasing

ANSWER: A.

TOPIC: 293008
KNOWLEDGE: K1.04 [2.6/2.7]
QID: B2385 (P2386)

Subcooled reactor coolant enters the bottom of a fuel assembly in a reactor operating at power. As the coolant flows upward through the fuel assembly, boiling occurs and the coolant exits the fuel assembly at the saturation temperature.

If the coolant had remained subcooled, average fuel temperature would have been _____ because boiling is a _____ efficient method of heat transfer.

- A. higher; more
- B. higher; less
- C. lower; more
- D. lower; less

ANSWER: A.

TOPIC: 293008
KNOWLEDGE: K1.04 [2.6/2.7]
QID: B2486 (P2686)

Case 1: Subcooled reactor coolant enters the bottom of a fuel assembly in a reactor operating at power. As the coolant flows upward through the fuel assembly, the water heats up and exits the fuel assembly still subcooled.

Case 2: Same as above, except that reactor pressure is decreased such that the coolant begins to boil halfway up the fuel assembly, which results in a saturated steam-water mixture exiting the fuel assembly.

Assume that departure from nucleate boiling is avoided in both cases and that power level does not change. As compared to Case 1, the average fuel temperature for Case 2 will be _____ because boiling is a _____ efficient method of heat transfer.

- A. higher; more
- B. higher; less
- C. lower; more
- D. lower; less

ANSWER: C.

TOPIC: 293008
KNOWLEDGE: K1.04 [2.6/2.7]
QID: B2986 (P2986)

Subcooled reactor coolant enters the bottom of a fuel assembly and exits the top of the fuel assembly as a saturated steam-water mixture with a quality of 10 percent. How does the value of the convective heat transfer coefficient change as the coolant travels upward through the fuel assembly?

- A. Increases only
- B. Increases, then decreases
- C. Decreases only
- D. Decreases, then increases

ANSWER: A.

TOPIC: 293008
KNOWLEDGE: K1.04 [2.6/2.7]
QID: B3785 (P3786)

Subcooled water enters a fuel assembly in a reactor operating at power. As the water flows upward through the fuel assembly, the water begins to boil and exits the fuel assembly as a saturated steam-water mixture.

If fuel assembly power is unchanged and system pressure is increased such that all of the water remains subcooled, the average fuel temperature in the fuel assembly would be _____ because boiling is a _____ efficient method of heat transfer.

- A. higher; more
- B. higher; less
- C. lower; more
- D. lower; less

ANSWER: A.

TOPIC: 293008
KNOWLEDGE: K1.04 [2.6/2.7]
QID: B5744 (P5745)

Initially, subcooled water is flowing into a fuel assembly with subcooled water exiting the fuel assembly several degrees hotter than when it entered. No boiling is occurring in the fuel assembly. Assume that fuel assembly thermal power and water flow rate remain the same.

System pressure is decreased, causing some of the water in contact with the fuel rods to boil during transit through the fuel assembly, but the water exiting the fuel assembly remains subcooled. Compared to the initial conditions, the average fuel temperature in the fuel assembly will be _____; and the temperature of the water exiting the fuel assembly will be _____.

- A. higher; the same
- B. higher; higher
- C. lower; the same
- D. lower; higher

ANSWER: D.

TOPIC: 293008
KNOWLEDGE: K1.06 [2.5/2.6]
QID: B387

Which one of the following conditions must occur to sustain natural convection in a fluid system?

- A. Subcooling of the fluid.
- B. A phase change in the fluid.
- C. An enthalpy change in the fluid.
- D. Radiative heat transfer to the fluid.

ANSWER: C.

TOPIC: 293008
KNOWLEDGE: K1.06 [2.5/2.6]
QID: B2386 (P1989)

Which one of the following conditions must occur to sustain natural convection in a fluid system?

- A. Subcooling of the fluid.
- B. A phase change in the fluid.
- C. A density change in the fluid.
- D. Radiative heat transfer to the fluid.

ANSWER: C.

TOPIC: 293008
KNOWLEDGE: K1.07 [2.8/3.0]
QID: B388 (P387)

What type of boiling is described as follows?

The bulk temperature of the liquid is below saturation, but the temperature of the heat transfer surface is above saturation. Vapor bubbles form at the heat transfer surface, but condense in the bulk liquid so that no net generation of vapor is obtained.

- A. Bulk boiling
- B. Subcooled nucleate boiling
- C. Transition boiling
- D. Partial film boiling

ANSWER: B.

TOPIC: 293008
KNOWLEDGE: K1.07 [2.8/3.0]
QID: B887

Refer to the drawing of a pool-boiling curve (see figure below).

In which region of the curve is nucleate boiling the primary mode of heat transfer?

- A. Region I
- B. Region II
- C. Region III
- D. Region IV

ANSWER: B.

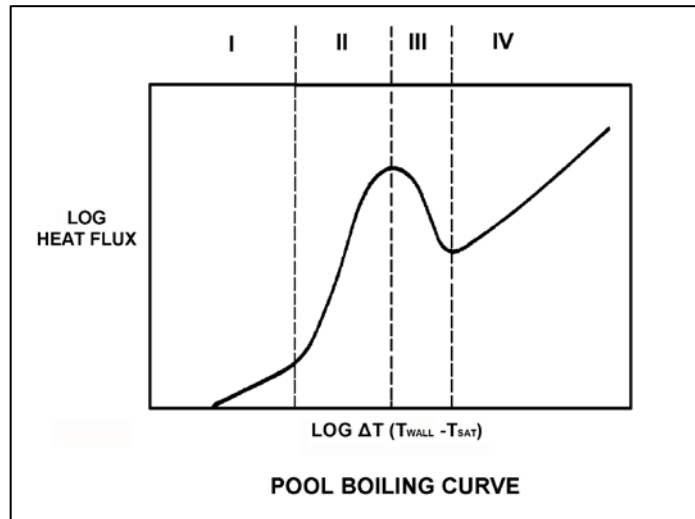

TOPIC: 293008
KNOWLEDGE: K1.07 [2.8/3.0]
QID: B1087 (P1686)

For coolant flowing past a fuel rod, which one of the following is a characteristic of subcooled nucleate boiling, but not bulk boiling?

- A. T_{Cladding} equals T_{Sat} .
- B. T_{Cladding} is greater than T_{Sat} .
- C. $T_{\text{Bulk Coolant}}$ equals T_{Sat} .
- D. $T_{\text{Bulk Coolant}}$ is less than T_{Sat} .

ANSWER: D.

TOPIC: 293008
KNOWLEDGE: K1.07 [2.8/3.0]
QID: B1287 (P2687)

Which one of the following modes of heat transfer is characterized by steam bubbles moving away from a heated surface and collapsing in the bulk fluid?

- A. Bulk boiling
- B. Subcooled nucleate boiling
- C. Saturated nucleate boiling
- D. Saturated natural convection

ANSWER: B.

TOPIC: 293008
KNOWLEDGE: K1.07 [2.8/3.0]
QID: B1786 (P1888)

For coolant flowing past a fuel rod, which one of the following is a characteristic of bulk boiling, but not subcooled nucleate boiling?

- A. T_{Cladding} equals T_{Sat} .
- B. T_{Cladding} is greater than T_{Sat} .
- C. $T_{\text{Bulk Coolant}}$ equals T_{Sat} .
- D. $T_{\text{Bulk Coolant}}$ is less than T_{Sat} .

ANSWER: C.

TOPIC: 293008
KNOWLEDGE: K1.07 [2.8/3.0]
QID: B1986 (P1186)

Refer to the drawing of a pool boiling curve (see figure below). In which region of the curve does the most efficient form of heat transfer occur?

- A. Region I
- B. Region II
- C. Region III
- D. Region IV

ANSWER: B.

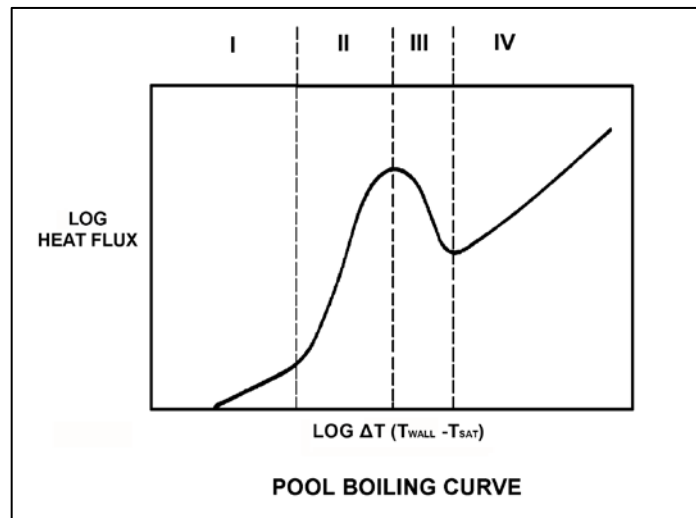

TOPIC: 293008
KNOWLEDGE: K1.07 [2.8/3.0]
QID: B2088 (P1286)

Refer to the drawing of a pool boiling curve (see figure below).

Which region of the curve contains the operating point at which the hottest locations of a reactor normally operate to transfer heat from the fuel cladding to the coolant at 100 percent power?

- A. Region I
- B. Region II
- C. Region III
- D. Region IV

ANSWER: B.

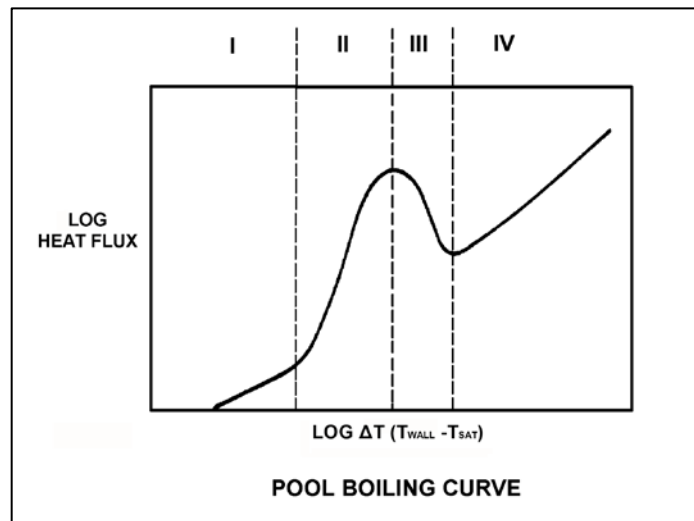

TOPIC: 293008
KNOWLEDGE: K1.07 [2.8/3.0]
QID: B3685 (P3686)

A nuclear power plant is currently shut down after several months of operation at 100 percent power. The shutdown cooling system is in operation, maintaining an average reactor coolant temperature of 280°F. A pressure control malfunction causes reactor coolant pressure to slowly and continuously decrease from 100 psia while reactor coolant temperature remains constant.

Which one of the following describes the location where nucleate boiling will first occur?

- A. At a scratch on the surface of a fuel rod near the top of a fuel assembly.
- B. At a scratch on the surface of a fuel rod near the bottom of a fuel assembly.
- C. In the bulk fluid of a coolant channel near the top of a fuel assembly.
- D. In the bulk fluid of a coolant channel near the bottom of a fuel assembly.

ANSWER: A.

TOPIC: 293008
KNOWLEDGE: K1.08 [2.9/3.1]
QID: B142

Which one of the following describes the onset of transition boiling?

- A. Steam bubbles begin to blanket the fuel rod causing a rapid increase in the ΔT between the fuel rod and the coolant.
- B. Steam bubbles completely blanket the fuel rod causing an increase in the heat flux from the fuel rod.
- C. Steam bubbles begin to blanket the fuel rod causing a rapid decrease in ΔT between the fuel rod and the coolant.
- D. Steam bubbles break up the laminar layer of coolant on the surface of the fuel rod causing an increase in the heat flux from the fuel rod.

ANSWER: A.

TOPIC: 293008
KNOWLEDGE: K1.08 [2.9/3.1]
QID: B287

Departure from nucleate boiling (DNB) occurs when steam bubbles begin to blanket the fuel rod, resulting in a rapid _____ in heat transfer rate and a rapid _____ in ΔT (fuel cladding minus coolant temperature).

- A. decrease; increase
- B. decrease; decrease
- C. increase; increase
- D. increase; decrease

ANSWER: A.

TOPIC: 293008
KNOWLEDGE: K1.08 [2.9/3.1]
QID: B1288 (P3388)

Which one of the following is indicated by a rapid increase in the temperature difference between the fuel cladding and the bulk coolant?

- A. Bulk boiling is occurring.
- B. Nucleate boiling is occurring.
- C. Critical heat flux is increasing.
- D. Departure from nucleate boiling is occurring.

ANSWER: D.

TOPIC: 293008
KNOWLEDGE: K1.08 [2.9/3.1]
QID: B1985 (P1288)

Departure from nucleate boiling should not be allowed to occur in the core because...

- A. as steam bubbles begin to blanket the fuel rod, the radiative heat transfer decreases.
- B. as steam bubbles in the coolant form and then collapse, water hammer occurs.
- C. as steam bubbles begin to blanket the fuel rod, its temperature rises sharply.
- D. as steam bubbles form in the coolant, voids-induced reactivity changes cause undesirable power changes.

ANSWER: C.

TOPIC: 293008
KNOWLEDGE: K1.08 [2.9/3.1]
QID: B2987 (P287)

Which one of the following describes the heat transfer from a fuel rod experiencing departure from nucleate boiling? (Note: ΔT refers to the difference between the fuel rod surface temperature and the bulk coolant saturation temperature.)

- A. Steam bubbles begin to blanket the fuel rod surface, causing a rapid increase in the ΔT for a given heat flux.
- B. Steam bubbles completely blanket the fuel rod surface, causing a rapid decrease in the ΔT for a given heat flux.
- C. Steam bubbles begin to form on the fuel rod surface, causing a rapid increase in the heat flux from the fuel rod for a given ΔT .
- D. Steam bubbles completely blanket the fuel rod surface, causing a rapid increase in the heat flux from the fuel rod for a given ΔT .

ANSWER: A.

TOPIC: 293008
KNOWLEDGE: K1.09 [3.0/3.2]
QID: B288

Refer to the drawing of a hypothetical fuel bundle coolant channel (see figure below).

For the hypothetical fuel bundle coolant channel shown below, at what point along its length does transition boiling begin?

- A. 1
- B. 2
- C. 3
- D. 4

ANSWER: C.

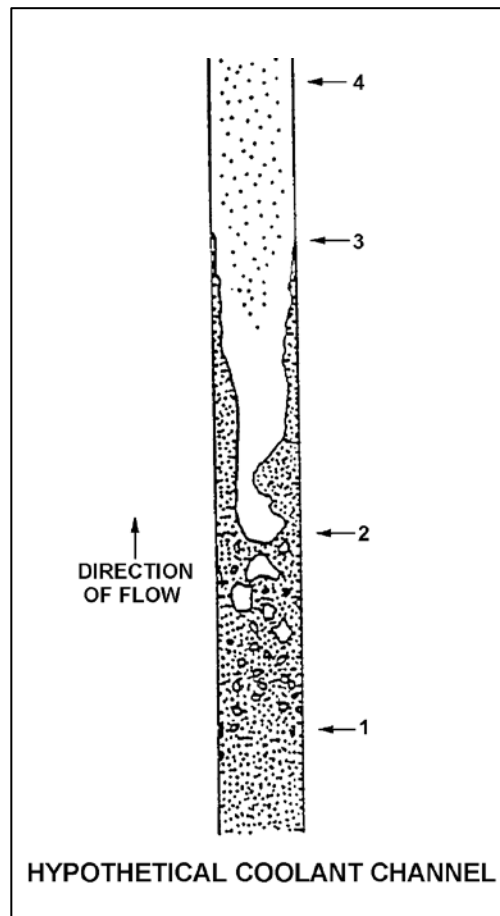

TOPIC: 293008
KNOWLEDGE: K1.09 [3.0/3.2]
QID: B987 (P1891)

Which one of the following describes the heat transfer conditions in a fuel assembly that is experiencing transition boiling?

- A. Complete steam blanketing of the fuel rod surface.
- B. Alternate wetting and drying of the fuel rod surface.
- C. Saturated nucleate boiling.
- D. Subcooled nucleate boiling.

ANSWER: B.

TOPIC: 293008
KNOWLEDGE: K1.09 [3.0/3.2]
QID: B1386 (P1689)

Refer to the drawing of a pool boiling curve (see figure below).

Which one of the points shown marks the onset of transition boiling?

- A. A
- B. B
- C. C
- D. D

ANSWER: B.

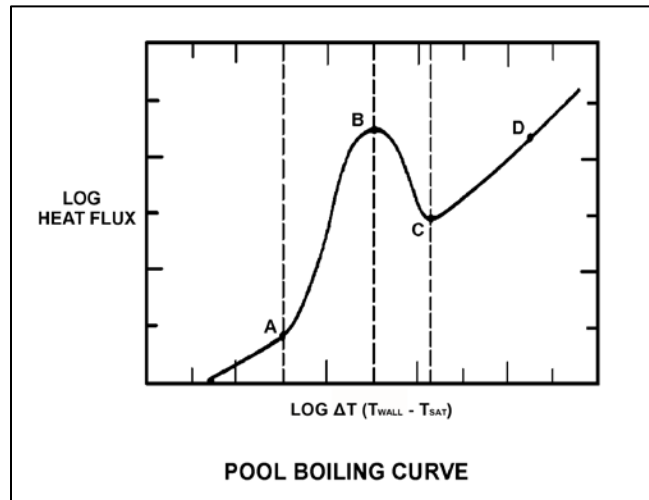

TOPIC: 293008
KNOWLEDGE: K1.09 [3.0/3.2]
QID: B1486 (P2688)

Refer to the drawing of a pool boiling curve (see figure below).

Which one of the following regions represents the most unstable mode of heat transfer?

- A. Region I
- B. Region II
- C. Region III
- D. Region IV

ANSWER: C.

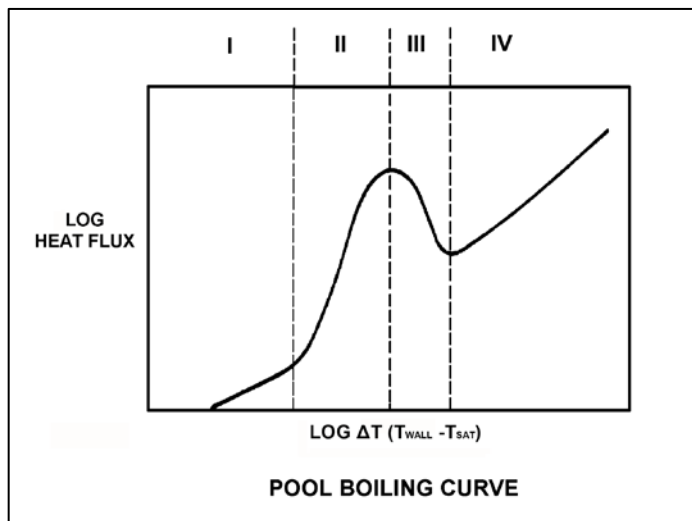

TOPIC: 293008
KNOWLEDGE: K1.09 [3.0/3.2]
QID: B1587 (P1587)

Refer to the drawing of a pool boiling curve (see figure below).

Which one of the points shown marks the smallest ΔT at which stable film boiling can exist?

- A. A
- B. B
- C. C
- D. D

ANSWER: C.

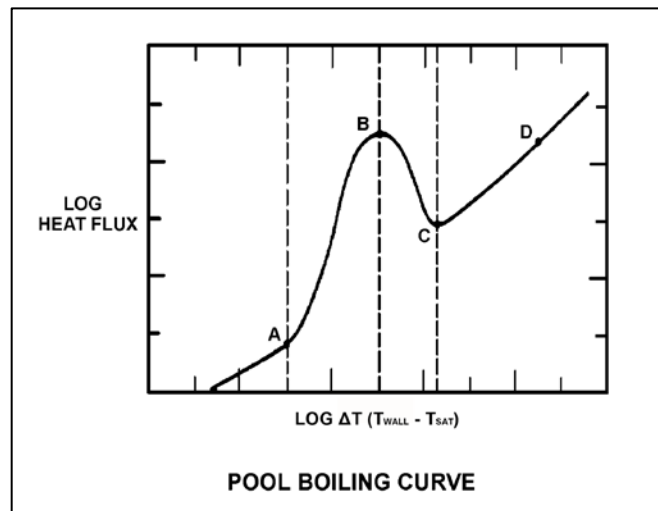

TOPIC: 293008
KNOWLEDGE: K1.09 [3.0/3.2]
QID: B2288 (P1987)

Which one of the following describes the conditions in a fuel assembly that is experiencing transition boiling?

- A. Complete steam blanketing of the fuel rod surface.
- B. Alternate wetting and drying of the fuel rod surface.
- C. Steam bubbles form and collapse on the fuel rod surface.
- D. Steam bubbles form on the fuel rod surface and are swept away by subcooled bulk coolant.

ANSWER: B.

TOPIC: 293008
KNOWLEDGE: K1.10 [2.9/3.0]
QID: B289 (P2289)

Refer to the drawing of a pool-boiling curve (see figure below).

With heat flux continuously increasing, the point at which the critical heat flux is reached (point B), marks the beginning of...

- A. nucleate boiling.
- B. stable film boiling.
- C. partial film boiling.
- D. single-phase convection.

ANSWER: C.

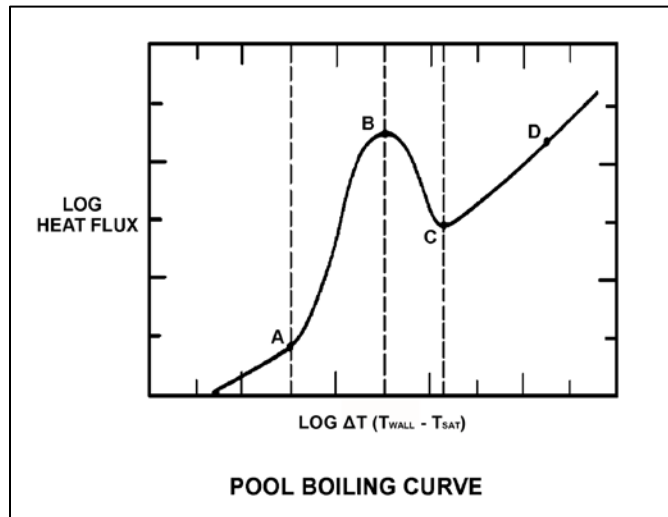

TOPIC: 293008
KNOWLEDGE: K1.10 [2.9/3.0]
QID: B390

The magnitude of the local fuel pin heat flux that is necessary to cause the onset of transition boiling is...

- A. greatest at the top of the core and smallest at the bottom of the core.
- B. greatest at the bottom of the core and smallest at the top of the core.
- C. greatest at the core midplane and smallest at the top and bottom of the core.
- D. greatest at the top and bottom of the core and smallest at the core midplane.

ANSWER: B.

TOPIC: 293008
KNOWLEDGE: K1.10 [2.9/3.0]
QID: B1687

A reactor is operating at 100 percent power. Which one of the following will be the initial type of fuel damage experienced if a fuel rod exceeds the critical heat flux?

- A. Loss of cladding integrity
- B. Loss of pellet integrity
- C. Pellet-cladding interaction
- D. Cladding creep

ANSWER: A.

TOPIC: 293008
KNOWLEDGE: K1.10 [2.9/3.0]
QID: B1888

How does the critical heat flux vary from the bottom to the top of a typical fuel bundle while operating at 100 percent power?

- A. Decreases continuously.
- B. Decreases, then increases.
- C. Increases continuously.
- D. Increases, then decreases.

ANSWER: A.

TOPIC: 293008
KNOWLEDGE: K1.10 [2.9/3.0]
QID: B2487

A reactor is shutdown at normal operating temperature and pressure. Which one of the following will decrease the critical heat flux for the reactor fuel? (Assume the reactor remains shutdown.)

- A. Fully withdrawing one control rod.
- B. Increasing reactor vessel water level by 12 inches.
- C. Increasing reactor recirculation flow rate by 100 gpm.
- D. Increasing reactor pressure by 10 psig.

ANSWER: D.

TOPIC: 293008
KNOWLEDGE: K1.11 [2.7/2.8]
QID: B91

Which one of the following describes transition (partial film) boiling? (ΔT refers to the difference between the fuel rod surface temperature and the coolant saturation temperature.)

- A. A small increase in ΔT causes increased steam blanketing and a reduction in heat flux.
- B. The temperature of the heat transfer surface is so high that thermal radiative heat transfer becomes significant and heat flux increases.
- C. As the ΔT increases, the increasing number of steam bubbles causes increased agitation and turbulence of the boundary layer, allowing increased heat flux.
- D. As the ΔT increases, a few vapor bubbles are formed that may collapse when they enter into the bulk of the fluid.

ANSWER: A.

TOPIC: 293008
KNOWLEDGE: K1.11 [2.7/2.8]
QID: B1289

A reactor is operating at full power with a fuel bundle that is experiencing each of the following modes of heat transfer somewhere along its length.

Which one of the following causes the first reduction in the local fuel cladding heat transfer rate as the coolant flows upward through the fuel bundle?

- A. Nucleate boiling
- B. Stable film boiling
- C. Partial film boiling
- D. Single-phase convection

ANSWER: C.

TOPIC: 293008
KNOWLEDGE: K1.11 [2.7/2.8]
QID: B1987 (P889)

If the fission rate in a reactor core steadily increases, the mode of heat transfer that occurs immediately after the critical heat flux is reached is called...

- A. transition boiling.
- B. subcooled nucleate boiling.
- C. saturated nucleate boiling.
- D. stable film boiling.

ANSWER: A.

TOPIC: 293008
KNOWLEDGE: K1.11 [2.7/2.8]
QID: B2185 (P2188)

Refer to the drawing of a pool boiling curve (see figure below).

Which one of the following describes the heat transfer conditions in a fuel assembly that is experiencing region III heat transfer?

- A. Complete steam blanketing of the fuel rod surface.
- B. Alternate wetting and drying of the fuel rod surface.
- C. Saturated nucleate boiling.
- D. Subcooled nucleate boiling.

ANSWER: B.

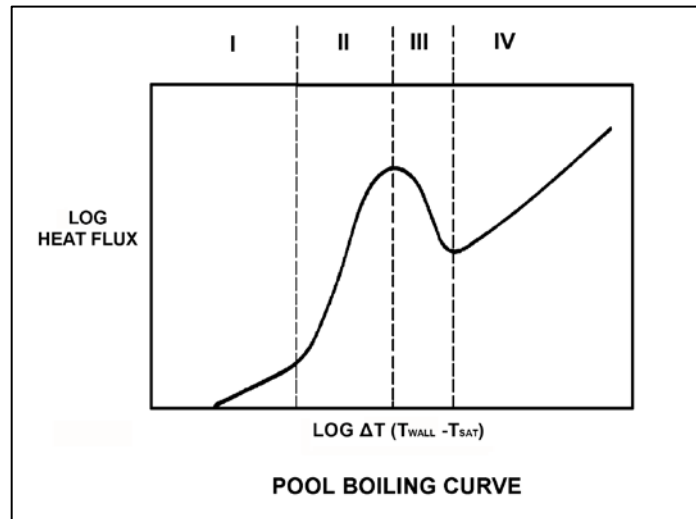

TOPIC: 293008
KNOWLEDGE: K1.12 [2.7/2.8]
QID: B2588 (P2588)

Refer to the drawing of a pool boiling curve (see figure below).

Which one of the following describes the conditions in a fuel assembly that is experiencing region IV heat transfer?

- A. Saturated nucleate boiling.
- B. Subcooled nucleate boiling.
- C. Complete steam blanketing of the fuel rod surface.
- D. Alternate wetting and drying of the fuel rod surface.

ANSWER: C.

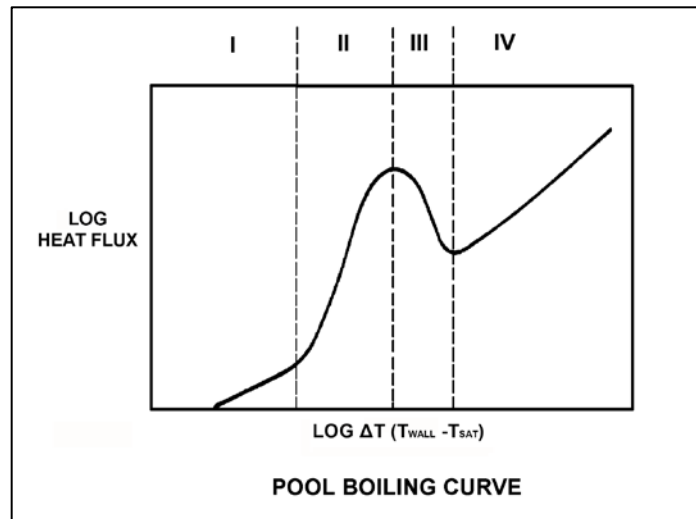

TOPIC: 293008
KNOWLEDGE: K1.12 [2.7/2.8]
QID: B3485 (P3488)

During a loss of coolant accident, some fuel rods may experience stable film boiling. Which one of the following types of heat transfer from the fuel cladding will increase significantly when stable film boiling begins?

- A. Forced convection
- B. Natural convection
- C. Conduction
- D. Radiation

ANSWER: D.

TOPIC: 293008
KNOWLEDGE: K1.17 [2.5/2.8]
QID: B1588

A reactor is operating at steady-state 90 percent power. Which one of the following will cause the two-phase coolant flowing upward in a fuel bundle to approach the onset of transition boiling? (Assume reactor power does not change unless stated.)

- A. Reactor pressure increases.
- B. Recirculation flow rate increases.
- C. Feedwater temperature decreases.
- D. Fuel bundle power decreases.

ANSWER: A.

TOPIC: 293008
KNOWLEDGE: K1.17 [2.5/2.8]
QID: B1891

A reactor is operating at steady-state 90 percent power. Which one of the following will cause the two-phase coolant flowing upward in a fuel bundle to approach the onset of transition boiling? (Assume reactor power does not change unless stated.)

- A. Recirculation flow rate decreases.
- B. Reactor pressure decreases.
- C. Feedwater temperature decreases.
- D. Fuel bundle power decreases.

ANSWER: A.

TOPIC: 293008
KNOWLEDGE: K1.17 [2.5/2.8]
QID: B2089

A reactor is operating at steady-state 70 percent power. Which one of the following will cause the two-phase coolant flowing upward in a fuel bundle to move away from the onset of transition boiling? (Assume reactor power does not change unless stated.)

- A. Recirculation flow rate increases.
- B. Reactor pressure increases.
- C. Feedwater temperature increases.
- D. Fuel bundle power increases.

ANSWER: A.

TOPIC: 293008
KNOWLEDGE: K1.17 [2.5/2.8]
QID: B2589

A reactor is operating at steady-state 90 percent power. Which one of the following will cause the two-phase coolant flowing upward in a fuel bundle to initially move away from the onset of transition boiling? (Assume reactor power does not change unless stated.)

- A. Recirculation flow rate decreases.
- B. Reactor pressure increases.
- C. Feedwater temperature decreases.
- D. Fuel bundle power increases.

ANSWER: C.

TOPIC: 293008
KNOWLEDGE: K1.17 [2.5/2.8]
QID: B2789

A reactor is operating at steady-state 90 percent power. Which one of the following will cause the two-phase coolant flowing upward in a fuel bundle to approach the onset of transition boiling? (Assume reactor power does not change unless stated.)

- A. Recirculation flow rate increases.
- B. Reactor pressure decreases.
- C. Feedwater temperature increases.
- D. Fuel bundle power decreases.

ANSWER: C.

TOPIC: 293008
KNOWLEDGE: K1.19 [2.6/2.8]
QID: B789

Core inlet subcooling is defined as the difference between the saturation temperature of the fluid in the core inlet plenum and the temperature of the fluid...

- A. in the core inlet plenum.
- B. at the feedwater pump discharge.
- C. in the downcomer area.
- D. in the lower fuel channel area.

ANSWER: A.

TOPIC: 293008
KNOWLEDGE: K1.20 [2.4/2.6]
QID: B790

Carryunder is most damaging to which one of the following components?

- A. Main turbine
- B. Moisture separator (turbine)
- C. Recirculation pump
- D. Moisture separator (reactor vessel)

ANSWER: C.

TOPIC: 293008
KNOWLEDGE: K1.20 [2.4/2.6]
QID: B989

Which one of the following actions will initially reduce core inlet subcooling?

- A. Isolate steam to one feedwater heater.
- B. Increase reactor recirculation mass flow rate.
- C. Decrease the mass ratio of saturated water-to-saturated steam returning to the downcomer.
- D. Increase the mass ratio of saturated water-to-saturated steam returning to the downcomer.

ANSWER: C.

TOPIC: 293008
KNOWLEDGE: K1.21 [3.0/3.0]
QID: B290

Void fraction is the ratio of the _____ of steam to the _____ of steam-water mixture at a given elevation in a fuel channel.

- A. volume; mass
- B. mass; mass
- C. volume; volume
- D. mass; volume

ANSWER: C.

TOPIC: 293008
KNOWLEDGE: K1.21 [3.0/3.0]
QID: B1487

Given the following conditions for a 10 lbm steam-water mixture:

Steam quality = 20 percent
Pressure = 1,000 psia

Which one of the following is the approximate void fraction?

- A. 42 percent
- B. 48 percent
- C. 84 percent
- D. 96 percent

ANSWER: C.

TOPIC: 293008
KNOWLEDGE: K1.21 [3.0/3.0]
QID: B1689

Given the following conditions for a 10 lbm steam-water mixture:

Steam quality = 30 percent
Pressure = 1,000 psia

Which one of the following is the void fraction?

- A. 10.1 percent
- B. 11.3 percent
- C. 88.7 percent
- D. 89.9 percent

ANSWER: D.

TOPIC: 293008
KNOWLEDGE: K1.21 [3.0/3.0]
QID: B2389

Given the following conditions for a 10 lbm steam-water mixture:

Steam quality = 40 percent
Pressure = 1,000 psia

Which one of the following is the void fraction?

- A. 93.2 percent
- B. 89.9 percent
- C. 10.1 percent
- D. 6.8 percent

ANSWER: A.

TOPIC: 293008
KNOWLEDGE: K1.21 [3.0/3.0]
QID: B2690

Which one of the following ratios can be used to calculate the core void fraction?

- A. $\frac{\text{Steam Volume}}{\text{Water Volume}}$
- B. $\frac{\text{Steam Volume}}{\text{Steam Volume} + \text{Water Volume}}$
- C. $\frac{\text{Steam Volume} + \text{Water Volume}}{\text{Steam Volume} - \text{Water Volume}}$
- D. $\frac{\text{Steam Volume} + \text{Water Volume}}{\text{Steam Volume} \times \text{Water Volume}}$

ANSWER: B.

TOPIC: 293008
KNOWLEDGE: K1.22 [2.9/3.0]
QID: B587

A nuclear power plant is operating at steady-state 80 percent power. If reactor recirculation flow rate is decreased from 100 percent to 80 percent, the boiling boundary will initially move _____ the fuel rod because each unit quantity of water is receiving _____ heat from the fuel.

- A. up; more
- B. up; fewer
- C. down; more
- D. down; fewer

ANSWER: C.

TOPIC: 293008
KNOWLEDGE: K1.22 [2.9/3.0]
QID: B2091

A reactor is initially operating at steady-state 70 percent power when recirculation flow rate is increased by 5 percent.

Which one of the following statements describes the initial response of the boiling boundary in the core?

- A. It physically moves upward, because each unit quantity of coolant must travel farther through a fuel bundle before vaporizing.
- B. It physically moves upward, because each unit quantity of coolant enters the core with a larger subcooled margin.
- C. It physically moves downward, because each unit quantity of coolant will vaporize sooner as it travels through a fuel bundle.
- D. It physically moves downward, because each unit quantity of coolant enters the core with a smaller subcooled margin.

ANSWER: A.

TOPIC: 293008
KNOWLEDGE: K1.23 [2.5/2.7]
QID: B688

Which one of the following is the appropriate quality of a saturated steam-water mixture leaving a cyclone separator at 985 psig and 1174 Btu/lbm?

- A. 95 percent
- B. 96 percent
- C. 97 percent
- D. 98 percent

ANSWER: C.

TOPIC: 293008
KNOWLEDGE: K1.23 [2.5/2.7]
QID: B1387

Which one of the following is the appropriate quality of a saturated steam-water mixture leaving a cyclone separator at 985 psig and 1180 Btu/lbm?

- A. 96 percent
- B. 97 percent
- C. 98 percent
- D. 99 percent

ANSWER: C.

TOPIC: 293008
KNOWLEDGE: K1.23 [2.5/2.7]
QID: B1788

Which one of the following is the approximate quality of a saturated steam-water mixture leaving a fuel bundle at 948 psig and 905 Btu/lbm?

- A. 27 percent
- B. 44 percent
- C. 56 percent
- D. 73 percent

ANSWER: C.

TOPIC: 293008
KNOWLEDGE: K1.24 [2.4/2.5]
QID: B391

Refer to the drawing of a fuel rod and adjacent coolant flow channel (see figure below).

With a power plant operating at steady-state 100 percent reactor power at the beginning of a fuel cycle, which one of the following has the greater temperature difference?

- A. Coolant laminar layer
- B. Cladding corrosion film
- C. Zircaloy cladding
- D. Pellet-to-cladding gap

ANSWER: D.

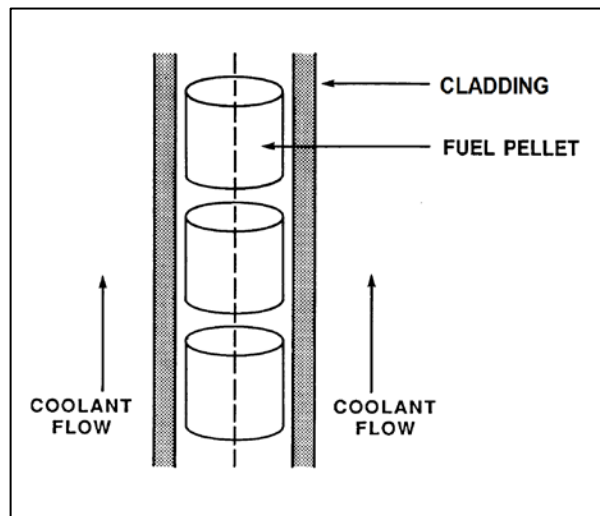

TOPIC: 293008
KNOWLEDGE: K1.24 [2.4/2.5]
QID: B1989 (P391)

Refer to the drawing of a fuel rod and adjacent coolant flow channel (see figure below).

With a nuclear power plant operating at steady-state 100 percent reactor power at the beginning of a fuel cycle, which one of the following has the greater temperature difference?

- A. Fuel pellet centerline-to-pellet surface
- B. Fuel pellet surface-to-cladding gap
- C. Zircaloy cladding
- D. Coolant laminar layer

ANSWER: A.

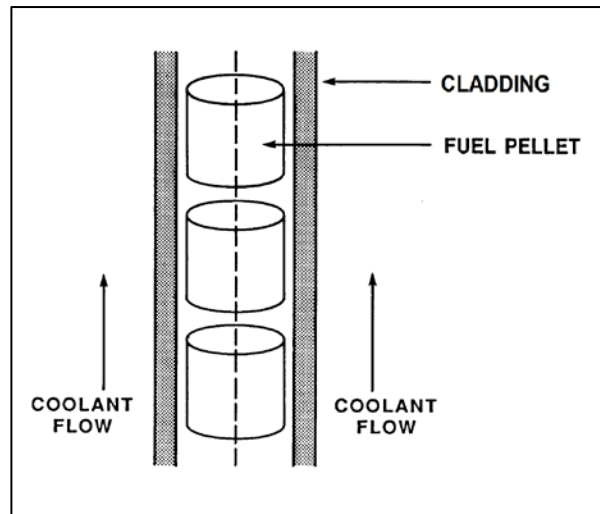

TOPIC: 293008
KNOWLEDGE: K1.25 [3.2/3.2]
QID: B1189

Forced circulation through a reactor core is required at all times during power operation to prevent...

- A. the core from becoming prompt critical due to high fuel and coolant temperatures.
- B. exceeding reactor vessel and core design steaming rates.
- C. high fuel cladding surface temperatures, which could result in a crack or leak in the cladding.
- D. jet pump cavitation, which could reduce the power generated by the core.

ANSWER: C.

TOPIC: 293008
KNOWLEDGE: K1.25 [3.2/3.2]
QID: B3789

Which one of the following describes the relationship between the feedwater mass flow rate entering the reactor vessel and the core mass flow rate at steady-state 100 percent reactor power?

- A. The mass flow rates are about the same as long as the reactor vessel downcomer level is constant.
- B. The mass flow rates are about the same as long as the reactor recirculation mass flow rate is constant.
- C. The feedwater mass flow rate is much smaller than the core mass flow rate because most of the core mass flow is returned to the reactor vessel downcomer by the steam separators.
- D. The feedwater mass flow rate is much larger than the core mass flow rate because the feedwater pump differential pressure is much larger than the core differential pressure.

ANSWER: C.

TOPIC: 293008
KNOWLEDGE: K1.26 [2.9/3.1]
QID: B1389

Refer to the drawing of a core recirculation jet pump (see figure below).

The highest pressure will exist at point ____; and the highest velocity will occur at point ____.

- A. 1; 4
- B. 2; 4
- C. 1; 3
- D. 2; 3

ANSWER: C.

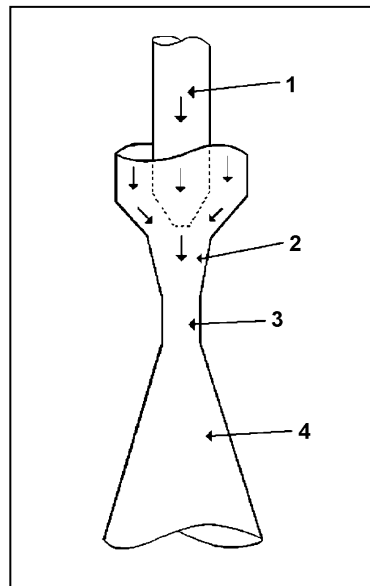

TOPIC: 293008
KNOWLEDGE: K1.26 [2.9/3.1]
QID: B2791

Refer to the drawing of a core recirculation jet pump (see figure below).

During normal operation, the lowest pressure will exist at point ____; and the highest velocity will occur at point ____.

- A. 3; 3
- B. 3; 4
- C. 4; 3
- D. 4; 4

ANSWER: A.

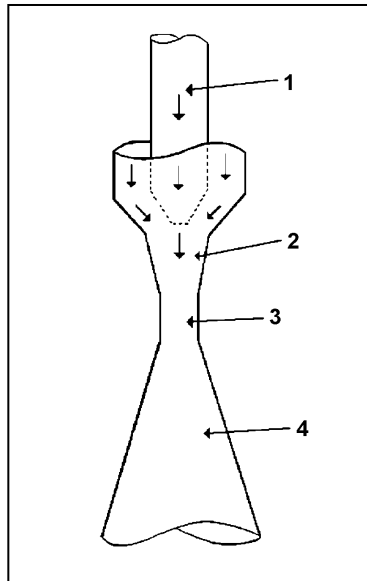

TOPIC: 293008
KNOWLEDGE: K1.28 [2.3/2.5]
QID: B490

A reactor is operating at steady-state 100 percent power when recirculation flow is decreased from 100 percent to 80 percent. During the flow reduction, the boiling boundary will move _____ in the core because each pound-mass of water flowing through the core is required to remove _____ heat from the fuel rods.

- A. upward; less
- B. upward; more
- C. downward; less
- D. downward; more

ANSWER: D.

TOPIC: 293008
KNOWLEDGE: K1.28 [2.3/2.5]
QID: B1789 (P1790)

Single-phase coolant flow resistance in a reactor core is directly proportional to the square of coolant _____; and inversely proportional to _____.

- A. velocity; fuel assembly length
- B. temperature; fuel assembly length
- C. velocity; coolant channel cross-sectional area
- D. temperature; coolant channel cross-sectional area

ANSWER: C.

TOPIC: 293008
KNOWLEDGE: K1.28 [2.3/2.5]
QID: B5445 (P5446)

Refer to the drawing of a section of pipe that contains flowing subcooled water (see figure below).

Given:

- Pressure at P_1 is 24 psig.
- Pressure at P_2 is 16 psig.
- Pressure change due to change in velocity is 2 psig.
- Pressure change due to change in elevation is 10 psig.

The pressure decrease due to friction head loss between P_1 and P_2 is _____; and the direction of flow is from _____.

- A. 2 psig; left to right
- B. 2 psig; right to left
- C. 4 psig; left to right
- D. 4 psig; right to left

ANSWER: D.

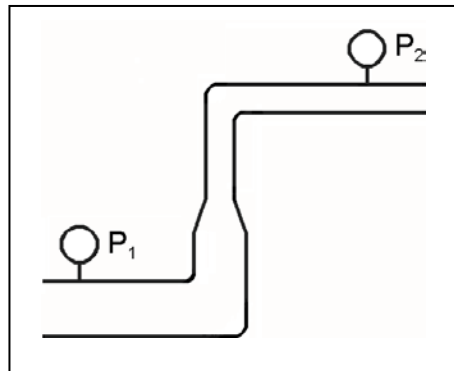

TOPIC: 293008
KNOWLEDGE: K1.28 [2.3/2.5]
QID: B5845 (P5847)

Refer to the drawing of a section of pipe that contains flowing subcooled water (see figure below).

Given:

- Pressure at P_1 is 26 psig.
- Pressure at P_2 is 34 psig.
- Pressure change due to change in velocity is 2 psig.
- Pressure change due to change in elevation is 8 psig.

The pressure decrease due to friction head loss between P_1 and P_2 is _____; and the direction of flow is from _____.

- A. 2 psig; left to right
- B. 2 psig; right to left
- C. 4 psig; left to right
- D. 4 psig; right to left

ANSWER: A.

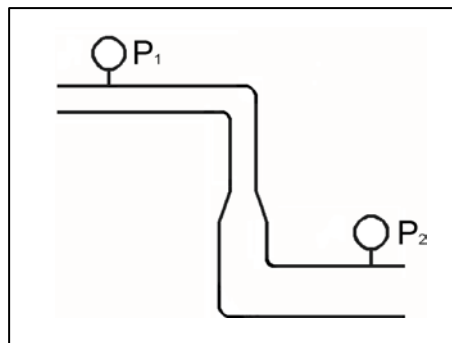

TOPIC: 293008
KNOWLEDGE: K1.28 [2.3/2.5]
QID: B6646 (P6648)

Refer to the drawing of a section of pipe that contains flowing subcooled water. (See figure below).

Given:

- Pressure at P_1 is 30 psig.
- Pressure at P_2 is 32 psig.
- Pressure change due to change in velocity is 2 psig.
- Pressure change due to change in elevation is 2 psig.

The pressure decrease due to friction head loss between P_1 and P_2 is _____; and the direction of flow is from _____.

- A. 2 psig; left to right
- B. 2 psig; right to left
- C. 6 psig; left to right
- D. 6 psig; right to left

ANSWER: B.

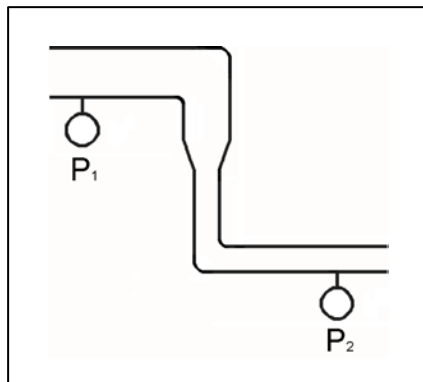

TOPIC: 293008
KNOWLEDGE: K1.28 [2.3/2.5]
QID: B7046 (P7048)

Refer to the drawing of a section of pipe that contains flowing subcooled water (see figure below).

Given:

- Pressure at P_1 is 34 psig.
- Pressure at P_2 is 20 psig.
- Pressure change due to change in velocity is 2 psig.
- Pressure change due to change in elevation is 8 psig.

The pressure decrease due to friction head loss between P_1 and P_2 is _____; and the direction of flow is from _____.

- A. 2 psig; left to right
- B. 2 psig; right to left
- C. 4 psig; left to right
- D. 4 psig; right to left

ANSWER: D.

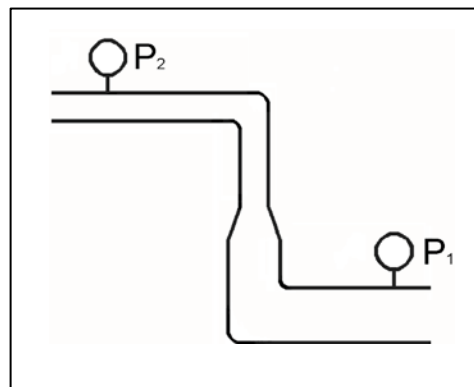

TOPIC: 293008
KNOWLEDGE: K1.28 [2.3/2.5]
QID: B7680 (P7680)

Refer to the drawing of a section of pipe that contains flowing subcooled water (see figure below).

Given:

- The pressure at P_1 is 20 psig.
- The pressure at P_2 is 20 psig.
- The pressure change caused by the change in velocity is 2 psig.
- The pressure change caused by the change in elevation is 8 psig.

The pressure decrease due to friction head loss between P_1 and P_2 is _____; and the direction of flow is from _____.

- A. 6 psig; left to right
- B. 6 psig; right to left
- C. 10 psig; left to right
- D. 10 psig; right to left

ANSWER: B.

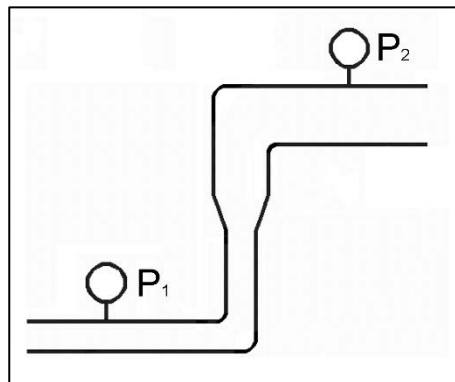

TOPIC: 293008
KNOWLEDGE: K1.29 [2.8/3.0]
QID: B93

Which one of the following statements describes the effect of an increase in bundle power on bundle flow rate in a centrally located fuel bundle? (Assume total recirculation flow remains constant.)

- A. Bundle flow rate increases, because increased boiling causes the coolant density to decrease, thereby reducing flow resistance.
- B. Bundle flow rate decreases, because increased boiling increases backpressure from increased reactor steam dome pressure.
- C. Bundle flow rate increases, because increased boiling causes acceleration of coolant due to rapid expansion.
- D. Bundle flow rate decreases, because increased boiling increases backpressure due to increased turbulence.

ANSWER: D.

TOPIC: 293008
KNOWLEDGE: K1.29 [2.8/3.0]
QID: B2090

Reactors A and B are identical. Reactor A is operating at 75 percent power and reactor B is operating at 50 percent power. Both reactors have the same power distribution and core mass flow rate.

Compared to the center fuel bundle in reactor A, the center fuel bundle in reactor B has the _____ coolant flow rate and the _____ critical power.

- A. lower; lower
- B. lower; higher
- C. higher; lower
- D. higher; higher

ANSWER: D.

TOPIC: 293008
KNOWLEDGE: K1.29 [2.8/3.0]
QID: B2390

Reactors A and B are identical. Reactor A is operating at 50 percent power and reactor B is operating at 75 percent power. Both reactors have the same power distribution and core mass flow rate.

Compared to the center fuel bundle in reactor A, the center fuel bundle in reactor B has the _____ critical power and the _____ coolant flow rate.

- A. lower; lower
- B. lower; higher
- C. higher; lower
- D. higher; higher

ANSWER: A.

TOPIC: 293008
KNOWLEDGE: K1.29 [2.8/3.0]
QID: B5646

Reactors A and B are operating at steady-state 100 percent power. The reactors are identical except that reactor A has core orifices and reactor B does not. Both reactors have the same power distribution and core mass flow rate.

Compared to the center fuel bundle in reactor B, the center fuel bundle in reactor A will have the _____ exit steam quality and the _____ critical power.

- A. lower; lower
- B. lower; higher
- C. higher; lower
- D. higher; higher

ANSWER: B.

TOPIC: 293008
KNOWLEDGE: K1.30 [2.7/2.7]
QID: B590

Without core orifices, the coolant flow rate through a high-power bundle will be less than the flow rate through a low-power bundle because the...

- A. two-phase flow-friction multiplier will be greater in the low-power bundle.
- B. channel quality will be greater in the high-power bundle.
- C. bypass flow will be greater in the high-power bundle.
- D. thermal expansion of the fuel rods will be greater in the high-power bundle.

ANSWER: B.

TOPIC: 293008
KNOWLEDGE: K1.30 [2.7/2.7]
QID: B890

For a reactor operating at 100 percent power, if the core coolant flow orifices were all of equal size, the highest bundle coolant flow rates would be located in...

- A. low-power bundles, because of decreased flow resistance.
- B. low-power bundles, because of reduced control rod obstruction.
- C. high-power bundles, because of decreased flow resistance.
- D. high-power bundles, because of reduced control rod obstruction.

ANSWER: A.

TOPIC: 293008
KNOWLEDGE: K1.30 [2.7/2.7]
QID: B990

Reactors A and B are operating at steady-state 100 percent power. The reactors are identical except that reactor A has core orifices and reactor B does not. Both reactors have the same power distribution and core mass flow rate.

Compared to the center fuel bundle in reactor B, the center fuel bundle in reactor A will have the _____ critical power and the _____ coolant flow rate.

- A. lower; lower
- B. lower; higher
- C. higher; lower
- D. higher; higher

ANSWER: D.

TOPIC: 293008
KNOWLEDGE: K1.30 [2.7/2.7]
QID: B1190

A reactor is operating at the point of adding heat during a reactor heatup. With only single-phase flow in the reactor, core orificing causes core flow to be...

- A. highest in the periphery bundles.
- B. highest in the central bundles.
- C. the same for all bundles.
- D. unpredictable.

ANSWER: B.

TOPIC: 293008
KNOWLEDGE: K1.30 [2.7/2.7]
QID: B1590

Two reactors are operating at steady-state 50 percent power. The reactors are identical except that one reactor has core orifices and the other does not. Both reactors have the same power distribution and core mass flow rate.

The orificed core will have the _____ critical power and the _____ core differential pressure.

- A. higher; higher
- B. higher; lower
- C. lower; higher
- D. lower; lower

ANSWER: A.

TOPIC: 293008
KNOWLEDGE: K1.30 [2.7/2.7]
QID: B1691

A reactor is operating at 100 percent power at the beginning of core life. If core orifices were not used, the lowest bundle flow rate would exist in...

- A. peripheral bundles that have control rods partially inserted.
- B. central bundles that have control rods partially inserted.
- C. peripheral bundles that have control rods completely withdrawn.
- D. central bundles that have control rods completely withdrawn.

ANSWER: D.

TOPIC: 293008
KNOWLEDGE: K1.30 [2.7/2.7]
QID: B1790

Reactors A and B are operating at steady-state 100 percent power. The reactors are identical except that reactor A has core orifices and reactor B does not. Both reactors have the same power distribution and core mass flow rate.

Compared to the center fuel bundle in reactor A, the center fuel bundle in reactor B will have the _____ critical power and the _____ coolant flow rate.

- A. lower; lower
- B. lower; higher
- C. higher; lower
- D. higher; higher

ANSWER: A.

TOPIC: 293008
KNOWLEDGE: K1.30 [2.7/2.7]
QID: B2187

Reactors A and B are operating at steady-state 50 percent power. The reactors are identical except that reactor A has core orifices and reactor B does not. Both reactors have the same power distribution and core mass flow rate.

Reactor B will have the _____ critical power and the _____ core differential pressure.

- A. higher; higher
- B. higher; lower
- C. lower; higher
- D. lower; lower

ANSWER: D.

TOPIC: 293008
KNOWLEDGE: K1.30 [2.7/2.7]
QID: B2591

Reactors A and B are operating at steady-state 100 percent. The reactors are identical except that reactor A has core orifices and reactor B does not. Both reactors have the same power distribution and core mass flow rate.

Compared to the outer fuel bundles in reactor B, the outer fuel bundles in reactor A will have the _____ critical power and the _____ coolant flow rate.

- A. lower; lower
- B. lower; higher
- C. higher; lower
- D. higher; higher

ANSWER: A.

TOPIC: 293008
KNOWLEDGE: K1.31 [2.9/3.0]
QID: B291

Why are core flow orifices used in a reactor?

- A. To counteract the buoyant force of steam bubbles in high-powered fuel bundles.
- B. To improve the distribution of coolant flow to low- and high-powered fuel bundles.
- C. To limit the adverse effects of minor crud buildup on core flow.
- D. To reduce core flow during natural circulation to increase the void coefficient.

ANSWER: B.

TOPIC: 293008
KNOWLEDGE: K1.31 [2.9/3.0]
QID: B1388

Which one of the following occurs as a result of reactor core orifices?

- A. The core differential pressure is minimized at all power levels.
- B. The total core coolant flow rate remains the same at all power levels.
- C. The total core coolant flow rate is divided equally through all bundles at all power levels.
- D. The highest bundle coolant flow rates exist in core interior bundles at all power levels.

ANSWER: D.

TOPIC: 293008
KNOWLEDGE: K1.31 [2.9/3.0]
QID: B2890

Reactors A and B are operating at steady-state 100 percent power. The reactors are identical, except that reactor A uses the standard core orifice design, while reactor B uses equal-sized flow openings for all fuel bundles. Both reactors have the same power distribution and total core mass flow rate.

Compared to the center fuel bundle in reactor A, the center fuel bundle in reactor B has the _____ exit steam quality; and the _____ critical power.

- A. lower; lower
- B. lower; higher
- C. higher; lower
- D. higher; higher

ANSWER: C.

TOPIC: 293008
KNOWLEDGE: K1.31 [2.9/3.0]
QID: B3890

Given:

- Reactors A and B are identical except that reactor A has no core orifices while reactor B is equipped with orifices.
- Both reactors always operate with identical recirculation system flow rates.
- Both reactors are operating at steady-state 80 percent power.
- Both reactors have the same core power distribution.

Compared to reactor A, the critical power ratio (CPR) in the central fuel bundles of reactor B is _____; and the average power in the peripheral fuel bundles of reactor B is _____.

- A. smaller; smaller
- B. smaller; larger
- C. larger; smaller
- D. larger; larger

ANSWER: C.

TOPIC: 293008
KNOWLEDGE: K1.32 [2.5/2.6]
QID: B690

Core bypass flow is...

- A. undesirable, but cannot be prevented due to machined clearances in the reactor vessel.
- B. desirable, because it provides cooling for low-power areas of the core.
- C. undesirable, because it makes actual core flow hard to measure.
- D. desirable, because it provides cooling for incore instrumentation.

ANSWER: D.

TOPIC: 293008
KNOWLEDGE: K1.32 [2.5/2.6]
QID: B2991

Which one of the following is the approximate percentage of total core flow that bypasses the fuel coolant channels in a reactor operating at 100 percent power with 100 percent recirculation flow?

- A. 0.01 percent
- B. 0.1 percent
- C. 1 percent
- D. 10 percent

ANSWER: D.

TOPIC: 293008
KNOWLEDGE: K1.32 [2.5/2.6]
QID: B3191

A reactor was initially operating at steady-state 100 percent power with 100 percent core flow rate. Reactor power was then decreased and stabilized at 75 percent using only control rods for reactivity control, while core flow rate was maintained at 100 percent.

During the power decrease, core bypass flow rate _____ because core pressure drop _____.

- A. decreased; increased
- B. decreased; decreased
- C. increased; increased
- D. increased; decreased

ANSWER: B.

TOPIC: 293008
KNOWLEDGE: K1.32 [2.5/2.6]
QID: B3290

A reactor is initially operating at steady-state 100 percent power. Reactor power is decreased to 80 percent while maintaining the total mass flow rate through the core region unchanged. During the power decrease, the core bypass flow rate will...

- A. increase, because two-phase flow resistance in the core is greater at 80 percent power.
- B. decrease, because two-phase flow resistance in the core is smaller at 80 percent power.
- C. remain the same, because core bypass flow rate is dependent only on reactor core flow rate.
- D. remain the same, because core bypass flow rate is unaffected by changes in reactor power.

ANSWER: B.

TOPIC: 293008
KNOWLEDGE: K1.33 [2.4/2.6]
QID: B384

What is the purpose of the coolant flow that bypasses the fuel bundles to enter the core interstitial regions?

- A. Removes the heat generated in the control rods and local power range monitors.
- B. Equalizes core differential pressure between the inlet and outlet plenums.
- C. Offsets the decrease in heat removal from the fuel bundles as two-phase flow resistance increases.
- D. Lubricates the interfacing surfaces of control rods and fuel channels to reduce sliding friction and wear.

ANSWER: A.

TOPIC: 293008
KNOWLEDGE: K1.33 [2.4/2.6]
QID: B1390

Reactor coolant flow that bypasses the core is necessary to...

- A. provide a source of water to the incore thermocouples to ensure they measure a representative coolant temperature.
- B. act as a neutron reflector to minimize fast neutron leakage.
- C. ensure that recirculation pump flow rate is adequate to prevent pump overheating.
- D. provide cooling to prevent excessive boiling in the bypass region.

ANSWER: D.

TOPIC: 293008
KNOWLEDGE: K1.34 [2.9/3.1]
QID: B192

Which one of the following statements describes natural circulation in the reactor vessel after a loss of offsite power?

- A. Coolant density in the downcomer and a reduction of density in the core region support the cycle.
- B. Two-phase flow in the separators allows steam to be removed and water to return to the downcomer region.
- C. Relief and safety valves provide a heat sink for decay heat; in spite of leakage, control rod drive flow is adequate to maintain inventory.
- D. Density of the coolant in the core region increases, allowing coolant in the downcomer to enter the core.

ANSWER: A.

TOPIC: 293008
KNOWLEDGE: K1.34 [2.9/3.1]
QID: B691

Which one of the following statements describes natural circulation in a shutdown reactor?
(Assume no isolation condenser exists.)

- A. The moisture separators return the liquid portion of the coolant mixture exiting the core to the downcomer where it cools and increases in density.
- B. The jet pump diffusers establish a thermal driving head by increasing the velocity of the coolant as it flows downward through the diffuser.
- C. Coolant flows from the downcomer into a reactor recirculation loop and is returned to the core.
- D. Emergency coolant injection establishes a thermal driving head by providing cold coolant to the downcomer.

ANSWER: A.

TOPIC: 293008
KNOWLEDGE: K1.35 [3.1/3.3]
QID: B293

A reactor is shut down with all reactor recirculating pumps stopped. Which one of the following explains why it is important to monitor reactor vessel skin temperatures?

- A. Significant differential temperature between the top and bottom reactor vessel heads will result in excessive thermal stresses in the reactor vessel wall.
- B. Significant differential temperature between the upper and lower elevation reactor vessel skin indicates that thermal stratification is occurring.
- C. These temperatures provide a backup indication of reactor water level because the skin temperatures detected above vessel water level will be lower than those below vessel water level.
- D. These temperatures provide the best indication of the accuracy of the shutdown reactor water level instruments due to the temperature variance from instrument calibration conditions.

ANSWER: B.

TOPIC: 293008
KNOWLEDGE: K1.35 [3.1/3.3]
QID: B3490

Given:

- A nuclear power plant was shut down one week ago from long-term operation at 100 percent power.
- All reactor recirculation pumps are off.
- All reactor head vents are open.
- A shutdown core cooling system is currently in use, maintaining reactor coolant temperature stable at 170°F.

Reactor coolant temperature is monitored by a detector at the inlet to the in-service shutdown core cooling heat exchanger.

The flow rate from the shutdown core cooling system to the core is inadvertently throttled, resulting in thermal stratification of the reactor coolant in the core. Which one of the following combinations will occur if this thermal stratification is permitted to exist for 24 hours?

- A. Water in the core will begin to boil, and the in-service shutdown cooling pump will cavitate.
- B. The in-service shutdown cooling pump will cavitate, and the jet pumps will cavitate.
- C. The jet pumps will cavitate, and reactor coolant temperature will indicate lower than actual core water temperature.
- D. Reactor coolant temperature will indicate lower than actual core water temperature, and water in the core will begin to boil.

ANSWER: D.

TOPIC: 293008
KNOWLEDGE: K1.36 [3.1/3.3]
QID: B1491

Initially, a reactor was operating at steady-state 100 percent power when a loss of offsite power caused a reactor scram and a loss of forced reactor coolant flow. Several minutes later, the occurrence of natural circulation flow will be indicated by a differential _____ across the core plate and coolant flow through the _____ pumps.

- A. temperature; recirculation
- B. temperature; jet
- C. pressure; recirculation
- D. pressure; jet

ANSWER: D.

TOPIC: 293008
KNOWLEDGE: K1.36 [3.1/3.3]
QID: B3891

A reactor was shut down from long-term 100 percent power operation 10 days ago. Five minutes ago, a station blackout caused a complete loss of forced coolant circulation through the core. The following conditions currently exist:

- Reactor vessel (RV) pressure indicates 0 psig.
- Main steam isolation valves are closed.
- Reactor head vents are open with no steam issuing.
- Average reactor coolant temperature is 150°F.
- Differential temperature between the upper and lower RV heads is 20°F and increasing.

Over the next hour or so, which one of the following will occur without operator action as natural circulation becomes established in the RV?

- A. RV pressure will slowly increase and stabilize at about 10 psig, and the differential temperature between the upper and lower RV heads will stabilize at a value greater than 0°F.
- B. RV pressure will slowly increase and stabilize at about 10 psig, and the differential temperature between the upper and lower RV heads will stabilize at 0°F.
- C. RV pressure will remain near 0 psig, and the differential temperature between the upper and lower RV heads will stabilize at a value greater than 0°F.
- D. RV pressure will remain near 0 psig, and the differential temperature between the upper and lower RV heads will stabilize at 0°F.

ANSWER: C.

TOPIC: 293008
KNOWLEDGE: K1.37 [3.2/3.4]
QID: B891

While a reactor is shut down, what effect will decreasing reactor water level to just below the steam separators have on natural circulation flow rate?

- A. Flow rate will significantly decrease due to the loss of communication between the annulus and the core.
- B. Flow rate will decrease initially and then increase to a new equilibrium value slightly less than the original flow rate.
- C. Flow rate will increase to a new stable value as the temperature of the water in the core increases to a new stable value.
- D. Flow rate will not be significantly affected because the thermal driving head is primarily dependent on the differential temperature between the core and the annulus.

ANSWER: A.

TOPIC: 293008
KNOWLEDGE: K1.37 [3.2/3.4]
QID: B3086

After operating at a high power level for several weeks, a reactor was shut down several days ago and cooled down to repair a steam line leak. Shutdown cooling water pumps are currently being used to maintain reactor temperature and pressure. The pumps will be stopped in 30 minutes to test repairs.

What action, if any, should be taken to enhance natural circulation cooling during the test, and why?

- A. No action is necessary; the increase of density in the downcomer and the reduction of density in the core region will easily support natural circulation.
- B. No action is necessary; as the density of the mixture in the core region increases, the liquid in the downcomer will flow into the core.
- C. Raise reactor vessel pressure to allow vessel relief valves to lift to create a heat sink for decay heat while control rod drive flow maintains inventory.
- D. Raise reactor vessel water level above the bottom of the steam separators to provide a liquid flow path from the inside to the outside of the core shroud.

ANSWER: D.