

TOPIC: 193008
KNOWLEDGE: K1.01 [2.8/3.0]
QID: P986

Which one of the following is an example of significant radiative heat transfer?

- A. Heat transfer from the fuel pellet to the fuel cladding via direct contact.
- B. Heat transfer from the reactor coolant to the feedwater in a steam generator.
- C. Heat transfer from the center to the edge of a fuel pellet at end of core life.
- D. Heat transfer from the fuel cladding to the reactor coolant through a stable vapor layer.

ANSWER: D.

TOPIC: 193008
KNOWLEDGE: K1.01 [2.8/3.0]
QID: P1186 (B1986)

Refer to the drawing of a pool boiling curve (see figure below). In which region of the curve does the most efficient form of heat transfer occur?

- A. Region I
- B. Region II
- C. Region III
- D. Region IV

ANSWER: B.

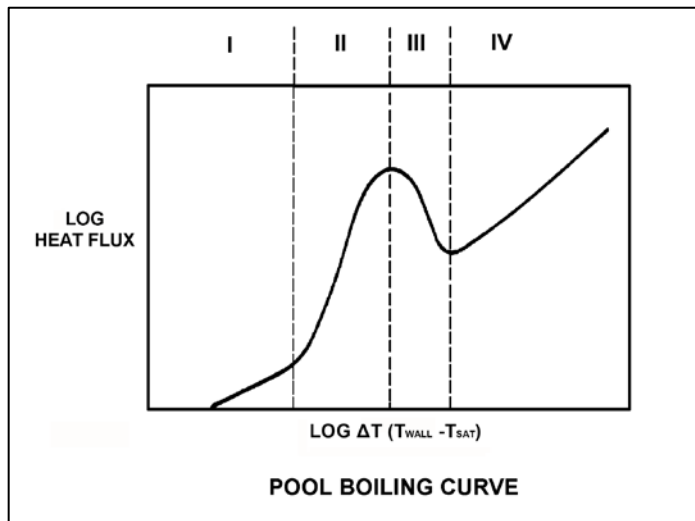

TOPIC: 193008
KNOWLEDGE: K1.01 [2.8/3.0]
QID: P1286 (B2088)

Refer to the drawing of a pool boiling curve (see figure below).

Which region of the curve contains the operating point at which the hottest locations of a reactor normally operate to transfer heat from the fuel cladding to the coolant at 100 percent power?

- A. Region I
- B. Region II
- C. Region III
- D. Region IV

ANSWER: B.

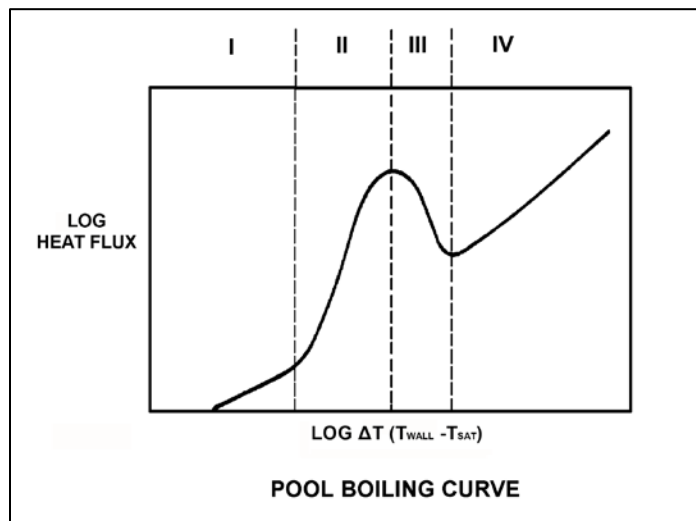

TOPIC: 193008
KNOWLEDGE: K1.02 [2.8/3.0]
QID: P85

Why does nucleate boiling improve heat transfer in a reactor core?

- A. The formation of steam bubbles at nucleation sites on the fuel rod allows more heat to be transferred by conduction.
- B. The formation of steam bubbles at nucleation sites on the fuel rod promotes local radiative heat transfer and allows more heat to be transferred by convection.
- C. Heat is removed from the fuel rod as both sensible heat and latent heat of condensation, and the heat is transferred directly to the coolant by radiative heat transfer.
- D. Heat is removed from the fuel rod as both sensible heat and latent heat of vaporization, and the motion of the steam bubbles causes rapid mixing of the coolant.

ANSWER: D.

TOPIC: 193008
KNOWLEDGE: K1.02 [2.8/3.0]
QID: P886

Convection heat transfer improves when nucleate boiling begins on the surface of a fuel rod because:

- A. steam bubble formation decreases coolant flow rate along the fuel rod.
- B. steam bubble formation increases coolant flow rate along the fuel rod.
- C. a steam blanket begins to form along the surface of the fuel rod.
- D. the motion of the steam bubbles causes rapid mixing of the coolant.

ANSWER: D.

TOPIC: 193008
KNOWLEDGE: K1.02 [2.8/3.0]
QID: P1086 (B2784)

How does the convective heat transfer coefficient vary from the bottom to the top of a fuel assembly if reactor coolant enters the fuel assembly as subcooled water and exits as superheated steam?

- A. Increases continuously.
- B. Increases, then decreases.
- C. Decreases continuously.
- D. Decreases, then increases.

ANSWER: B.

TOPIC: 193008
KNOWLEDGE: K1.02 [2.8/3.0]
QID: P1187

Nucleate boiling affects heat transfer from a fuel rod primarily by...

- A. improving the conductive heat transfer from the fuel rod to the coolant.
- B. improving the convective heat transfer from the fuel rod to the coolant.
- C. degrading the conductive heat transfer from the fuel rod to the coolant.
- D. degrading the convective heat transfer from the fuel rod to the coolant.

ANSWER: B.

TOPIC: 193008
KNOWLEDGE: K1.02 [2.8/3.0]
QID: P2386

Subcooled water enters the bottom of an operating reactor core. As the water flows upward past the fuel assemblies, steam bubbles form on the surface of a few fuel rods and are swept away.

If the coolant at the surface of the affected fuel rods had remained subcooled, average fuel temperature in the affected fuel rods would have been _____ because single-phase convection is a _____ efficient method of heat transfer than boiling.

- A. higher; more
- B. higher; less
- C. lower; more
- D. lower; less

ANSWER: B.

TOPIC: 193008
KNOWLEDGE: K1.02 [2.8/3.0]
QID: P2686 (B2486)

Case 1: Subcooled reactor coolant enters the bottom of a fuel assembly in a reactor operating at power. As the coolant flows upward through the fuel assembly, the water heats up and exits the fuel assembly still subcooled.

Case 2: Same as above except that reactor pressure is decreased such that the coolant begins to boil halfway up the fuel assembly, which results in a saturated steam-water mixture exiting the fuel assembly.

Assume that departure from nucleate boiling is avoided in both cases and that power level does not change. As compared to Case 1, the average fuel temperature for Case 2 will be _____ because boiling is a _____ efficient method of heat transfer.

- A. higher; more
- B. higher; less
- C. lower; more
- D. lower; less

ANSWER: C.

TOPIC: 193008
KNOWLEDGE: K1.02 [2.8/3.0]
QID: P2986 (B2986)

Subcooled reactor coolant enters the bottom of a fuel assembly and exits the top of the fuel assembly as a saturated steam-water mixture. How does the convective heat transfer coefficient change as the coolant travels upward through the fuel assembly?

- A. Increases only
- B. Increases, then decreases
- C. Decreases only
- D. Decreases, then increases

ANSWER: A.

TOPIC: 193008
KNOWLEDGE: K1.02 [2.8/3.0]
QID: P3786 (B3785)

Subcooled water enters a fuel assembly in a reactor operating at power. As the water flows upward through the fuel assembly, the water begins to boil and exits the fuel assembly as a saturated steam-water mixture.

If fuel assembly power is unchanged and system pressure is increased such that all of the water remains subcooled, the average fuel temperature in the fuel assembly would be _____ because boiling is a _____ efficient method of heat transfer.

- A. higher; more
- B. higher; less
- C. lower; more
- D. lower; less

ANSWER: A.

TOPIC: 193008
KNOWLEDGE: K1.02 [2.8/3.0]
QID: P5745 (B5744)

Initially, subcooled water is flowing into a fuel assembly with subcooled water exiting the fuel assembly several degrees hotter than when it entered. No boiling is occurring in the fuel assembly. Assume that fuel assembly thermal power and water flow rate remain the same.

System pressure is decreased, causing some of the water in contact with the fuel rods to boil during transit through the fuel assembly, but the water exiting the fuel assembly remains subcooled. Compared to the initial conditions, the average fuel temperature in the fuel assembly will be _____; and the temperature of the water exiting the fuel assembly will be _____.

- A. higher; the same
- B. higher; higher
- C. lower; the same
- D. lower; higher

ANSWER: D.

TOPIC: 193008
KNOWLEDGE: K1.03 [2.8/3.1]
QID: P86

Subcooled nucleate boiling is occurring along a heated surface. If the heat flux is increased slightly, what will be the effect on the differential temperature (ΔT) between the heated surface and the fluid? (Assume subcooled nucleate boiling is still occurring.)

- A. Small increase in ΔT because of steam blanketing.
- B. Large increase in ΔT because of steam blanketing.
- C. Small increase in ΔT as vapor bubbles form and collapse.
- D. Large increase in ΔT causing radiative heat transfer to become significant.

ANSWER: C.

TOPIC: 193008
KNOWLEDGE: K1.03 [2.8/3.1]
QID: P286 (B389)

Which one of the following characteristics will enhance steam bubble formation in water adjacent to a heated surface?

- A. Chemicals dissolved in the water.
- B. The absence of ionizing radiation exposure to the water.
- C. A highly polished heat transfer surface with minimal scratches or cavities.
- D. The presence of gases dissolved in the water.

ANSWER: D.

TOPIC: 193008
KNOWLEDGE: K1.03 [2.8/3.1]
QID: P387 (B388)

What type of boiling is described as follows?

The bulk temperature of the liquid is below saturation, but the temperature of the heat transfer surface is above saturation. Vapor bubbles form at the heat transfer surface, but condense in the bulk liquid so that no net generation of vapor is obtained.

- A. Bulk boiling
- B. Subcooled nucleate boiling
- C. Transition boiling
- D. Partial film boiling

ANSWER: B.

TOPIC: 193008
KNOWLEDGE: K1.03 [2.8/3.1]
QID: P1686 (B1087)

Which one of the following is a characteristic of subcooled nucleate boiling but not saturated nucleate boiling?

- A. $T_{\text{Cladding}} = T_{\text{Sat}}$
- B. $T_{\text{Cladding}} > T_{\text{Sat}}$
- C. $T_{\text{Bulk Coolant}} = T_{\text{Sat}}$
- D. $T_{\text{Bulk Coolant}} < T_{\text{Sat}}$

ANSWER: D.

TOPIC: 193008
KNOWLEDGE: K1.03 [2.8/3.1]
QID: P1888 (B1786)

Which one of the following is a characteristic of saturated nucleate boiling but not subcooled nucleate boiling?

- A. T_{Cladding} equals T_{Sat}
- B. T_{Cladding} is greater than T_{Sat}
- C. $T_{\text{Bulk Coolant}}$ equals T_{Sat}
- D. $T_{\text{Bulk Coolant}}$ is less than T_{Sat}

ANSWER: C.

TOPIC: 193008
KNOWLEDGE: K1.03 [2.8/3.1]
QID: P2287 (B1086)

Which one of the following describes a reason for the increased heat transfer rate that occurs when nucleate boiling begins on the surface of a fuel rod?

- A. Steam bubbles have a greater thermal conductivity than water.
- B. The formation of steam bubbles increases coolant flow along the fuel rod.
- C. Radiative heat transfer begins to supplement convective heat transfer.
- D. The motion of the steam bubbles causes rapid mixing of the coolant.

ANSWER: D.

TOPIC: 193008
KNOWLEDGE: K1.03 [2.8/3.1]
QID: P2687 (B1287)

Which one of the following modes of heat transfer is characterized by steam bubbles moving away from a heated surface and collapsing in the bulk fluid?

- A. Bulk boiling
- B. Subcooled nucleate boiling
- C. Saturated nucleate boiling
- D. Saturated natural convection

ANSWER: B.

TOPIC: 193008
KNOWLEDGE: K1.03 [2.8/3.1]
QID: P2787 (B1285)

Which one of the following characteristics will enhance steam bubble formation in the coolant adjacent to a fuel rod?

- A. Surface scratches or cavities in the fuel cladding.
- B. Subsurface void defect in the fuel cladding.
- C. Increased coolant velocity past the fuel rod.
- D. Chemically inert material dissolved in the coolant.

ANSWER: A.

TOPIC: 193008
KNOWLEDGE: K1.03 [2.8/3.1]
QID: P3686 (B3685)

A nuclear power plant is currently shut down after several months of operation at 100 percent power. The shutdown cooling system is in operation, maintaining an average reactor coolant temperature of 280°F. A pressure control malfunction causes reactor coolant pressure to slowly and continuously decrease from 100 psia while reactor coolant temperature remains constant.

Which one of the following describes the location where nucleate boiling will first occur?

- A. At a scratch on the surface of a fuel rod near the top of a fuel assembly.
- B. At a scratch on the surface of a fuel rod near the bottom of a fuel assembly.
- C. In the bulk fluid of a coolant channel near the top of a fuel assembly.
- D. In the bulk fluid of a coolant channel near the bottom of a fuel assembly.

ANSWER: A.

TOPIC: 193008
KNOWLEDGE: K1.04 [3.1/3.3]
QID: P93

If departure from nucleate boiling occurs on the surface of a fuel rod, the surface temperature of the fuel rod will...

- A. increase rapidly.
- B. decrease rapidly.
- C. increase gradually.
- D. decrease gradually.

ANSWER: A.

TOPIC: 193008
KNOWLEDGE: K1.04 [3.1/3.3]
QID: P287 (B2987)

Which one of the following describes the heat transfer from a fuel rod experiencing departure from nucleate boiling? (Note: ΔT refers to the difference between the fuel rod surface temperature and the bulk coolant saturation temperature.)

- A. Steam bubbles begin to blanket the fuel rod surface, causing a rapid increase in the ΔT for a given heat flux.
- B. Steam bubbles completely blanket the fuel rod surface, causing a rapid decrease in the ΔT for a given heat flux.
- C. Steam bubbles begin to form on the fuel rod surface, causing a rapid increase in the heat flux from the fuel rod for a given ΔT .
- D. Steam bubbles completely blanket the fuel rod surface, causing a rapid increase in the heat flux from the fuel rod for a given ΔT .

ANSWER: A.

TOPIC: 193008
KNOWLEDGE: K1.04 [3.1/3.3]
QID: P1288 (B1985)

Departure from nucleate boiling should not be allowed to occur in the core because...

- A. as steam bubbles begin to blanket the fuel rod, the radiative heat transfer decreases.
- B. as steam bubbles in the coolant form and then collapse, water hammer occurs.
- C. as steam bubbles begin to blanket the fuel rod, its temperature rises sharply.
- D. as steam bubbles form in the coolant, voids-induced reactivity changes cause undesirable power changes.

ANSWER: C.

TOPIC: 193008
KNOWLEDGE: K1.04 [3.1/3.3]
QID: P3388 (B1288)

Which one of the following is indicated by a rapid increase in the temperature difference between the fuel cladding and the bulk coolant?

- A. Bulk boiling is occurring.
- B. Nucleate boiling is occurring.
- C. Critical heat flux is increasing.
- D. Departure from nucleate boiling is occurring.

ANSWER: D.

TOPIC: 193008
KNOWLEDGE: K1.05 [3.4/3.6]
QID: P138

Which one of the following reactor coolant system parameters has the least effect on margin to departure from nucleate boiling?

- A. Pressurizer level
- B. Local power density
- C. Cold leg temperature
- D. Coolant flow rate

ANSWER: A.

TOPIC: 193008
KNOWLEDGE: K1.05 [3.4/3.6]
QID: P144

An adequate subcooling margin during a loss of coolant accident is the most direct indication that _____ is being maintained.

- A. steam generator water level
- B. pressure level
- C. core cooling
- D. subcriticality

ANSWER: C.

TOPIC: 193008
KNOWLEDGE: K1.05 [3.4/3.6]
QID: P288

Which one of the following parameter changes will reduce the departure from nucleate boiling ratio?

- A. Decreasing reactor power.
- B. Increasing pressurizer pressure.
- C. Increasing reactor coolant flow rate.
- D. Increasing reactor coolant temperature.

ANSWER: D.

TOPIC: 193008
KNOWLEDGE: K1.05 [3.4/3.6]
QID: P1093

Which one of the following will increase the departure from nucleate boiling ratio?

- A. Increasing reactor coolant temperature.
- B. Increasing pressurizer pressure.
- C. Increasing core bypass flow.
- D. Increasing reactor power.

ANSWER: B.

TOPIC: 193008
KNOWLEDGE: K1.05 [3.4/3.6]
QID: P1787

A nuclear power plant is operating with the following initial conditions:

- Reactor power is 45 percent in the middle of a fuel cycle.
- Axial and radial power distributions are peaked in the center of the core.

Assuming reactor power level does not change, which one of the following will increase the steady-state departure from nucleate boiling ratio?

- A. One reactor coolant pump trips with automatic rod control.
- B. A spray valve malfunction decreases reactor coolant system pressure by 20 psig with no control rod motion.
- C. The operator decreases reactor coolant boron concentration by 5 ppm with no control rod motion.
- D. Core xenon-135 builds up in proportion to the axial and radial power distribution with automatic rod control.

ANSWER: D.

TOPIC: 193008
KNOWLEDGE: K1.05 [3.4/3.6]
QID: P1889

A nuclear power plant is operating with the following initial conditions:

- Reactor power is 45 percent in the middle of a fuel cycle.
- Axial and radial power distributions are peaked in the center of the core.

Which one of the following will decrease the steady-state departure from nucleate boiling ratio?

- A. A reactor trip occurs and one control rod remains fully withdrawn from the core.
- B. A pressurizer malfunction increases reactor coolant system pressure by 20 psig with no control rod motion.
- C. The operator decreases reactor coolant boron concentration by 5 ppm with no control rod motion.
- D. Core xenon-135 builds up in proportion to the axial and radial power distribution with automatic rod control.

ANSWER: C.

TOPIC: 193008
KNOWLEDGE: K1.05 [3.4/3.6]
QID: P2288

A nuclear power plant is operating with the following initial conditions:

- Reactor power is 55 percent in the middle of a fuel cycle.
- Axial and radial power distributions are peaked in the center of the core.

Which one of the following will decrease the steady-state departure from nucleate boiling ratio?

- A. A reactor trip occurs and one control rod remains fully withdrawn from the core.
- B. A pressurizer malfunction increases reactor coolant system pressure by 20 psig.
- C. The operator increases reactor coolant boron concentration by 5 ppm with no control rod motion.
- D. Core xenon-135 depletes in proportion to the axial and radial power distribution with no control rod motion.

ANSWER: D.

TOPIC: 193008
KNOWLEDGE: K1.05 [3.4/3.6]
QID: P2387

A nuclear power plant is operating with the following initial conditions:

- Reactor power is 45 percent in the middle of a fuel cycle.
- Axial and radial power distributions are peaked in the center of the core.

Which one of the following will decrease the steady-state departure from nucleate boiling ratio?

- A. A reactor trip occurs and one control rod remains fully withdrawn from the core.
- B. A pressurizer malfunction decreases reactor coolant system pressure by 20 psig.
- C. The operator increases reactor coolant boron concentration by 5 ppm with no control rod motion.
- D. Core xenon-135 builds up in proportion to the axial and radial power distribution with automatic rod control.

ANSWER: B.

TOPIC: 193008
KNOWLEDGE: K1.05 [3.4/3.6]
QID: P2487

A reactor is shutdown with all control rods inserted. The reactor coolant system (RCS) is at normal operating temperature and pressure. Which one of the following will decrease the departure from nucleate boiling ratio for the reactor? (Assume the reactor remains shutdown.)

- A. Fully withdrawing a bank of shutdown rods.
- B. Diluting RCS boron concentration by 50 ppm.
- C. Reducing RCS flow rate by one percent.
- D. Increasing RCS pressure by 10 psig.

ANSWER: C.

TOPIC: 193008
KNOWLEDGE: K1.05 [3.4/3.6]
QID: P2587

A nuclear power plant is operating with the following initial conditions:

- Reactor power is 55 percent in the middle of a fuel cycle.
- Axial and radial power distributions are peaked in the center of the core.

Which one of the following will increase the steady-state departure from nucleate boiling ratio?

- A. A reactor trip occurs and one control rod remains fully withdrawn from the core.
- B. A pressurizer malfunction decreases reactor coolant system pressure by 20 psig.
- C. The operator decreases reactor coolant boron concentration by 5 ppm with no rod motion.
- D. Core xenon-135 depletes in proportion to the axial and radial power distribution with no rod motion.

ANSWER: A.

TOPIC: 193008
KNOWLEDGE: K1.05 [3.4/3.6]
QID: P2788

A nuclear power plant is operating with the following initial conditions:

- Reactor power is 45 percent in the middle of a fuel cycle.
- Axial and radial power distributions are peaked in the center of the core.

Which one of the following will increase the steady-state departure from nucleate boiling ratio?

- A. Core xenon-135 decays with no change in the axial and radial power distributions.
- B. A reactor trip occurs and one control rod remains fully withdrawn from the core.
- C. The operator decreases reactor coolant boron concentration by 5 ppm with no control rod motion.
- D. A pressurizer malfunction decreases reactor coolant system pressure by 20 psig with no control rod motion.

ANSWER: B.

TOPIC: 193008
KNOWLEDGE: K1.05 [3.4/3.6]
QID: P2989

A reactor is shut down at normal operating temperature and pressure with all control rods inserted. Which one of the following will decrease the departure from nucleate boiling ratio for this reactor? (Assume the reactor remains shutdown.)

- A. Fully withdrawing a bank of shutdown rods.
- B. Diluting reactor coolant boron concentration by 50 ppm.
- C. Reducing reactor coolant temperature by 5°F.
- D. Decreasing reactor coolant pressure by 10 psig.

ANSWER: D.

TOPIC: 193008
KNOWLEDGE: K1.06 [2.8/2.9]
QID: P87

Which one of the following parameter changes would move a reactor farther away from the critical heat flux?

- A. Decrease pressurizer pressure.
- B. Decrease reactor coolant flow.
- C. Decrease reactor power.
- D. Increase reactor coolant temperature.

ANSWER: C.

TOPIC: 193008
KNOWLEDGE: K1.06 [2.8/2.9]
QID: P145

How does the critical heat flux vary from the bottom to the top of a typical fuel assembly during normal 100 percent power operation?

- A. Increases continuously.
- B. Increases, then decreases.
- C. Decreases continuously.
- D. Decreases, then increases.

ANSWER: C.

TOPIC: 193008
KNOWLEDGE: K1.06 [2.8/2.9]
QID: P587

The heat flux that causes departure from nucleate boiling is the...

- A. critical heat flux.
- B. nucleate heat flux.
- C. transition heat flux.
- D. departure heat flux.

ANSWER: A.

TOPIC: 193008
KNOWLEDGE: K1.06 [2.8/2.9]
QID: P989

The critical heat flux is the heat transfer rate per unit _____ of fuel rod that will initially cause _____.

- A. volume; nucleate boiling
- B. area; nucleate boiling
- C. volume; departure from nucleate boiling
- D. area; departure from nucleate boiling

ANSWER: D.

TOPIC: 193008
KNOWLEDGE: K1.06 [2.8/2.9]
QID: P1087

How does critical heat flux (CHF) vary with core height during normal full power operation?

- A. CHF increases from the bottom to the top of the core.
- B. CHF decreases from the bottom to the core midplane, then increases from the midplane to the top of the core.
- C. CHF decreases from the bottom to the top of the core.
- D. CHF increases from the bottom to the core midplane, then decreases from the midplane to the top of the core.

ANSWER: C.

TOPIC: 193008
KNOWLEDGE: K1.06 [2.8/2.9]
QID: P1586

A reactor is operating at steady-state 75 percent power. Which one of the following parameter changes will cause the core to operate closer to the critical heat flux? (Assume reactor power does not change unless stated.)

- A. Decrease reactor coolant flow rate by 5 percent.
- B. Decrease reactor power by 10 percent.
- C. Decrease reactor coolant temperature by 3°F.
- D. Increase pressurizer pressure by 20 psia.

ANSWER: A.

TOPIC: 193008
KNOWLEDGE: K1.06 [2.8/2.9]
QID: P3587

Which one of the following is most likely to result in fuel cladding damage?

- A. Operating at 110 percent of reactor vessel design pressure.
- B. An inadvertent reactor trip from 100 percent power.
- C. Operating at a power level that exceeds the critical heat flux.
- D. Operating with saturated nucleate boiling occurring in a fuel assembly.

ANSWER: C.

TOPIC: 193008
KNOWLEDGE: K1.07 [2.6/2.6]
QID: P689

A small increase in differential temperature at the fuel cladding-to-coolant interface causes increased steam blanketing and a reduction in heat flux. This describes which type of boiling?

- A. Subcooled boiling
- B. Nucleate boiling
- C. Partial film boiling
- D. Total film boiling

ANSWER: C.

TOPIC: 193008
KNOWLEDGE: K1.07 [2.6/2.6]
QID: P1089

Refer to the drawing of a pool boiling curve (see figure below).

Choose the region of the curve where transition boiling is the primary heat transfer process.

- A. Region I
- B. Region II
- C. Region III
- D. Region IV

ANSWER: C.

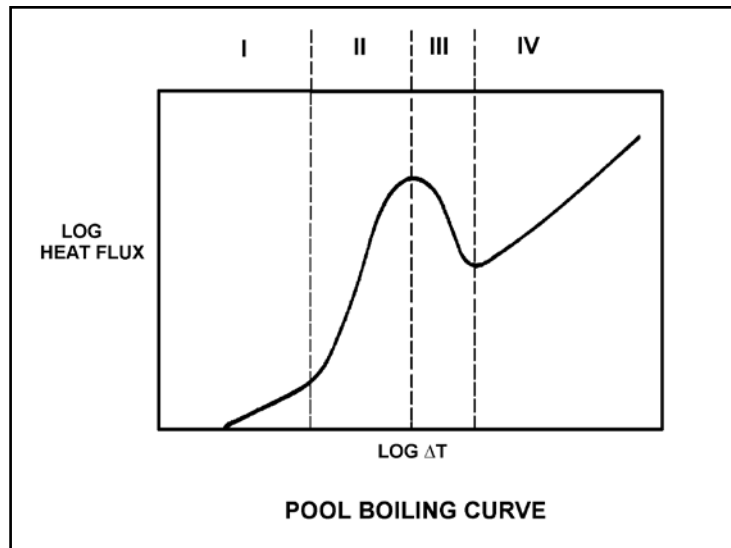

TOPIC: 193008
KNOWLEDGE: K1.07 [2.6/2.6]
QID: P1689 (B1386)

Refer to the drawing of a pool boiling curve (see figure below).

Which one of the points shown marks the onset of transition boiling?

- A. A
- B. B
- C. C
- D. D

ANSWER: B.

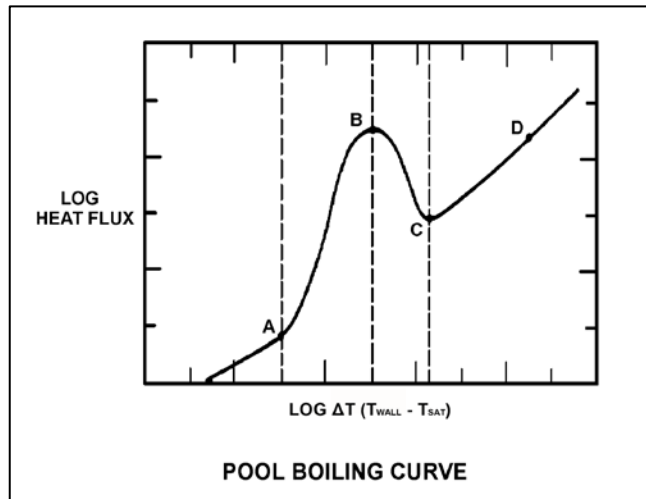

TOPIC: 193008
KNOWLEDGE: K1.07 [2.6/2.6]
QID: P1891 (B987)

Which one of the following describes the heat transfer conditions in a fuel assembly that is experiencing transition boiling?

- A. Complete steam blanketing of the fuel rod surface.
- B. Alternate wetting and drying of the fuel rod surface.
- C. Saturated nucleate boiling.
- D. Subcooled nucleate boiling.

ANSWER: B.

TOPIC: 193008
KNOWLEDGE: K1.07 [2.6/2.6]
QID: P1987 (B2288)

Which one of the following describes the conditions in a fuel assembly that is experiencing transition boiling?

- A. Complete steam blanketing of the fuel rod surface.
- B. Alternate wetting and drying of the fuel rod surface.
- C. Steam bubbles form and collapse on the fuel rod surface.
- D. Steam bubbles form on the fuel rod surface and are swept away by subcooled bulk coolant.

ANSWER: B.

TOPIC: 193008
KNOWLEDGE: K1.07 [2.6/2.6]
QID: P2188 (B2185)

Refer to the drawing of a pool boiling curve (see figure below).

Which one of the following describes the heat transfer conditions in a fuel assembly that is experiencing region III heat transfer?

- A. Complete steam blanketing of the fuel rod surface.
- B. Alternate wetting and drying of the fuel rod surface.
- C. Saturated nucleate boiling.
- D. Subcooled nucleate boiling.

ANSWER: B.

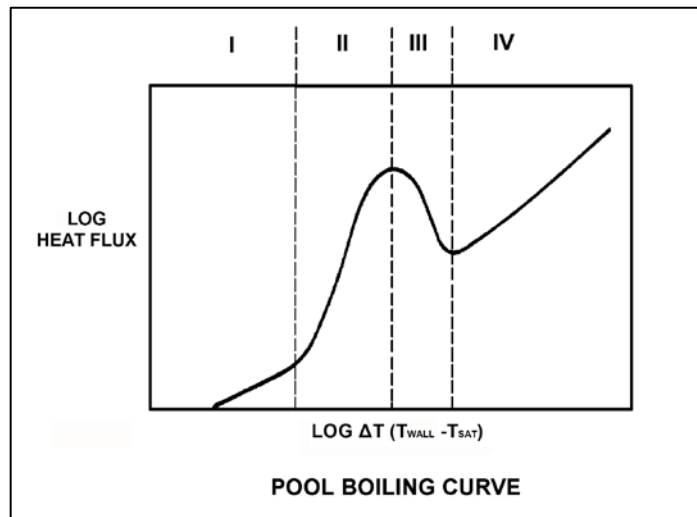

TOPIC: 193008
KNOWLEDGE: K1.07 [2.6/2.6]
QID: P2289 (B289)

Refer to the drawing of a pool-boiling curve (see figure below).

With heat flux continuously increasing, the point at which the critical heat flux is reached (point B), marks the beginning of...

- A. nucleate boiling.
- B. stable film boiling.
- C. partial film boiling.
- D. single-phase convection.

ANSWER: C.

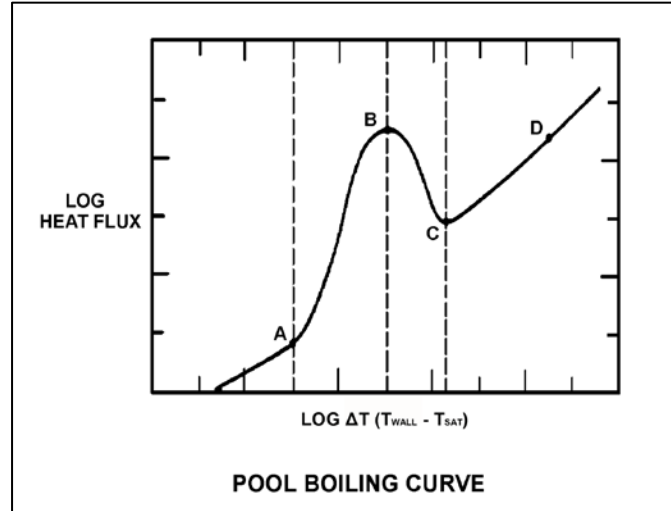

TOPIC: 193008
KNOWLEDGE: K1.07 [2.6/2.6]
QID: P2688 (B1486)

Refer to the drawing of a pool boiling curve (see figure below).

Which one of the following regions represents the most unstable mode of heat transfer?

- A. Region I
- B. Region II
- C. Region III
- D. Region IV

ANSWER: C.

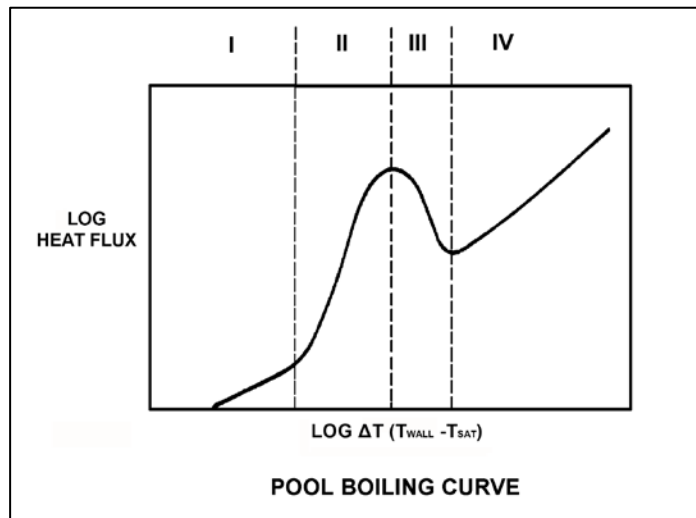

TOPIC: 193008
KNOWLEDGE: K1.08 [2.6/2.6]
QID: P88

Film boiling heat transfer is...

- A. the most efficient method of boiling heat transfer.
- B. heat transfer through an oxide film on the cladding.
- C. heat transfer being accomplished with no enthalpy change.
- D. heat transfer through a vapor blanket that covers the fuel cladding.

ANSWER: D.

TOPIC: 193008
KNOWLEDGE: K1.08 [2.6/2.6]
QID: P139

Reactor power is increased sufficiently to cause steam blanketing of several fuel rods. This condition is being caused by...

- A. departure from nucleate boiling.
- B. subcooled nucleate boiling.
- C. saturated nucleate boiling.
- D. onset of nucleate boiling.

ANSWER: A.

TOPIC: 193008
KNOWLEDGE: K1.08 [2.6/2.6]
QID: P889 (B1987)

If the fission rate in a reactor core steadily increases, the mode of heat transfer that occurs immediately after the critical heat flux is reached is called...

- A. transition boiling.
- B. subcooled nucleate boiling.
- C. saturated nucleate boiling.
- D. stable film boiling.

ANSWER: A.

TOPIC: 193008
KNOWLEDGE: K1.08 [2.6/2.6]
QID: P1587 (B1587)

Refer to the drawing of a pool boiling curve (see figure below).

Which one of the points shown marks the smallest ΔT at which stable film boiling can exist?

- A. A
- B. B
- C. C
- D. D

ANSWER: C.

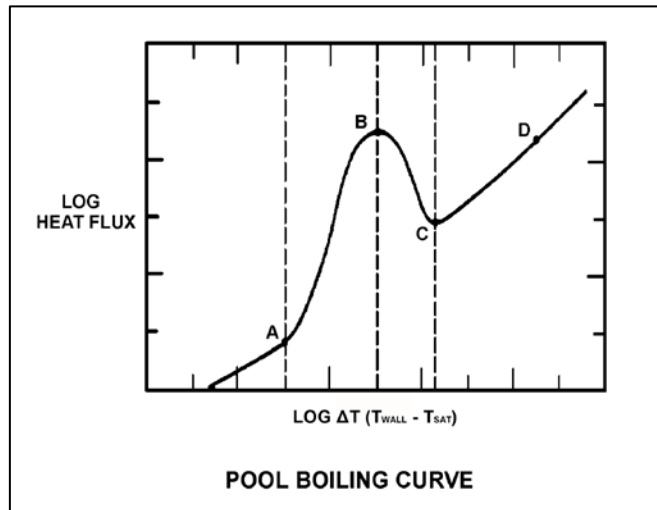

TOPIC: 193008
KNOWLEDGE: K1.08 [2.6/2.6]
QID: P2588 (B2588)

Refer to the drawing of a pool boiling curve (see figure below).

Which one of the following describes the conditions in a fuel assembly that is experiencing region IV heat transfer?

- A. Complete steam blanketing of the fuel rod surface.
- B. Alternate wetting and drying of the fuel rod surface.
- C. Saturated nucleate boiling.
- D. Subcooled nucleate boiling.

ANSWER: A.

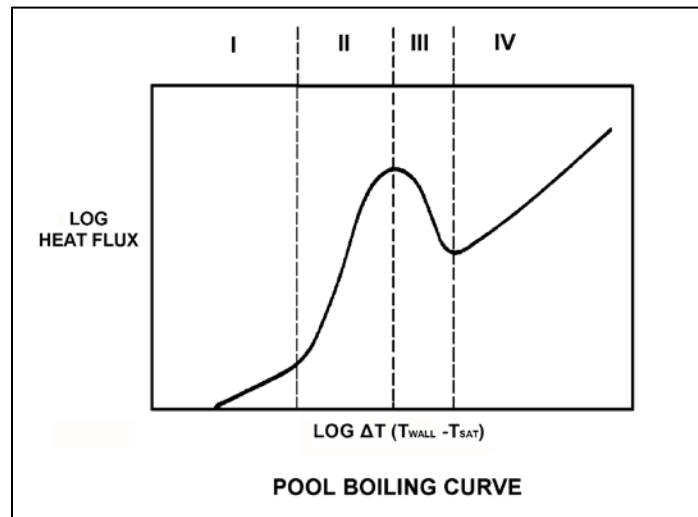

TOPIC: 193008
KNOWLEDGE: K1.08 [2.6/2.6]
QID: P3488 (B3485)

During a loss of coolant accident, some fuel rods may experience stable film boiling. Which one of the following types of heat transfer from the fuel cladding will increase significantly when stable film boiling begins?

- A. Forced convection
- B. Natural convection
- C. Conduction
- D. Radiation

ANSWER: D.

TOPIC: 193008
KNOWLEDGE: K1.10 [2.9/3.1]
QID: P89

The departure from nucleate boiling (DNB) ratio is defined as the...

- A. actual heat flux divided by the critical heat flux.
- B. critical heat flux divided by the actual heat flux.
- C. actual core thermal power divided by the rated core thermal power.
- D. rated core thermal power divided by the actual core thermal power.

ANSWER: B.

TOPIC: 193008
KNOWLEDGE: K1.10 [2.9/3.1]
QID: P289

In the definition of departure from nucleate boiling ratio, the term "actual heat flux" refers to the...

- A. heat transfer rate per unit area at any point along the fuel rod.
- B. average heat transfer rate per unit area across the core.
- C. integrated heat transfer rate along the entire fuel rod.
- D. total heat transfer rate along the entire fuel rod.

ANSWER: A.

TOPIC: 193008
KNOWLEDGE: K1.10 [2.9/3.1]
QID: P1190

A reactor is operating at steady-state 100 percent power near the end of a fuel cycle with all control rods fully withdrawn. At what axial location in a typical fuel assembly will the maximum departure from nucleate boiling ratio occur?

- A. At the top of the fuel assembly.
- B. At the bottom of the fuel assembly.
- C. Between the bottom and midplane of the fuel assembly.
- D. Between the midplane and the top of the fuel assembly.

ANSWER: B.

TOPIC: 193008
KNOWLEDGE: K1.10 [2.9/3.1]
QID: P2590

If a reactor is operating with the departure from nucleate boiling ratio at its limit, which one of the following is indicated?

- A. None of the fuel rods are experiencing critical heat flux.
- B. A small fraction of the fuel rods may be experiencing critical heat flux.
- C. All radioactive fission products are being contained within the reactor fuel.
- D. All radioactive fission products are being contained within either the reactor fuel or the reactor vessel.

ANSWER: B.

TOPIC: 193008
KNOWLEDGE: K1.14 [2.6/2.7]
QID: P389 (B588)

Core heat transfer rate is maximized by the presence of...

- A. laminar flow with no nucleate boiling.
- B. turbulent flow with no nucleate boiling.
- C. laminar flow with nucleate boiling.
- D. turbulent flow with nucleate boiling.

ANSWER: D.

TOPIC: 193008
KNOWLEDGE: K1.14 [2.6/2.7]
QID: P690

The heat transfer coefficient for the core will be directly increased if: (Assume bulk coolant subcooling.)

- A. the coolant temperature is decreased.
- B. the coolant flow rate is decreased.
- C. nucleate boiling occurs in the coolant.
- D. the coolant flow is laminar instead of turbulent.

ANSWER: C.

TOPIC: 193008
KNOWLEDGE: K1.14 [2.6/2.7]
QID: P891

Increasing coolant flow rate through a reactor core improves heat transfer from the fuel because a higher coolant flow rate _____ the laminar film thickness and _____ the temperature of the coolant adjacent to the fuel.

- A. increases; raises
- B. increases; lowers
- C. decreases; raises
- D. decreases; lowers

ANSWER: D.

TOPIC: 193008
KNOWLEDGE: K1.14 [2.6/2.7]
QID: P1691

Which one of the following will minimize core heat transfer?

- A. Laminar flow with no nucleate boiling.
- B. Turbulent flow with no nucleate boiling.
- C. Laminar flow with nucleate boiling.
- D. Turbulent flow with nucleate boiling.

ANSWER: A.

TOPIC: 193008
KNOWLEDGE: K1.15 [3.6/3.8]
QID: P90

A nuclear power plant is operating at 100 percent power. The reactor coolant subcooling margin will be directly reduced by...

- A. increasing reactor coolant temperature.
- B. increasing pressurizer pressure.
- C. increasing reactor coolant flow rate.
- D. increasing pressurizer level.

ANSWER: A.

TOPIC: 193008
KNOWLEDGE: K1.15 [3.6/3.8]
QID: P290

The difference between the actual temperature and the saturation temperature of a liquid is the...

- A. critical heat flux.
- B. saturation margin.
- C. subcooling margin.
- D. departure from nucleate boiling ratio.

ANSWER: C.

TOPIC: 193008
KNOWLEDGE: K1.15 [3.6/3.8]
QID: P393

Which one of the following must be present to assure adequate core cooling following a small loss of coolant accident?

- A. Subcooling margin greater than zero.
- B. Pressurizer level in the indicating range.
- C. Emergency cooling injection flow greater than zero.
- D. Pressurizer pressure greater than the safety injection actuation setpoint.

ANSWER: A.

TOPIC: 193008
KNOWLEDGE: K1.15 [3.6/3.8]
QID: P992

Which one of the following will increase the reactor coolant system (RCS) subcooling margin with the reactor operating at full power?

- A. Decreased RCS pressure.
- B. Decreased RCS hot leg temperature.
- C. Increased RCS cold leg temperature.
- D. Increased concentration of soluble gases in the RCS.

ANSWER: B.

TOPIC: 193008
KNOWLEDGE: K1.15 [3.6/3.8]
QID: P1491

A 60°F/hour reactor coolant system (RCS) cooldown and depressurization with natural circulation is in progress. After one hour, RCS subcooling will be minimum in the...

- A. reactor core.
- B. RCS loop hot leg.
- C. RCS loop cold leg.
- D. reactor vessel head.

ANSWER: D.

TOPIC: 193008
KNOWLEDGE: K1.15 [3.6/3.8]
QID: P2090

A reactor coolant system (RCS) cooldown and depressurization is in progress on natural circulation following a loss of offsite power. The following conditions currently exist:

RCS T_{cold} = 520°F, decreasing
RCS T_{hot} = 538°F, decreasing
Pressurizer pressure = 2,000 psia, decreasing

If the cooldown rate is being maintained at 50°F/hr, which one of the following locations is most likely to experience sustained steam voiding?

- A. Reactor vessel head
- B. RCS loop hot leg
- C. Steam generator U-tubes
- D. Reactor core

ANSWER: A.

TOPIC: 193008
KNOWLEDGE: K1.15 [3.6/3.8]
QID: P2591

Which one of the following is most likely to result in steam bubble formation in the reactor vessel head while maintaining a 60°F subcooling margin in the hottest reactor coolant system (RCS) hot leg?

- A. Performing a 25°F/hr RCS cooldown with natural circulation.
- B. Performing a 50°F/hr RCS cooldown with natural circulation.
- C. Performing a 25°F/hr RCS heatup with forced circulation.
- D. Performing a 50°F/hr RCS heatup with forced circulation.

ANSWER: B.

TOPIC: 193008
KNOWLEDGE: K1.15 [3.6/3.8]
QID: P2790

Which one of the following is most likely to result in steam bubble formation in a reactor vessel head while maintaining a 40°F subcooling margin in the hottest RCS hot leg?

- A. Performing a 25°F/hr RCS cooldown with natural circulation.
- B. Performing a 25°F/hr RCS cooldown with forced circulation.
- C. Performing a 50°F/hr RCS cooldown with natural circulation.
- D. Performing a 50°F/hr RCS cooldown with forced circulation.

ANSWER: C.

TOPIC: 193008
KNOWLEDGE: K1.15 [3.6/3.8]
QID: P2890

A nuclear power plant maintains the reactor coolant system (RCS) cold leg temperature (T_{cold}) at 557°F from 0 percent to 100 percent power. At 100 percent power, the reactor differential temperature ($T_{\text{hot}} - T_{\text{cold}}$) is 60°F.

If this plant also maintains RCS pressure constant at 2,235 psig, which one of the following is the approximate RCS subcooling margin at 50 percent power?

- A. 30°F
- B. 36°F
- C. 66°F
- D. 96°F

ANSWER: C.

TOPIC: 193008
KNOWLEDGE: K1.15 [3.6/3.8]
QID: P2991

Assume that a 30°F subcooling margin is maintained in the reactor coolant system (RCS) hot legs during each of the following shutdown reactor cooldown operations. Which one of the following will maintain the greatest subcooling margin in the reactor vessel head?

- A. Performing a 25°F/hr RCS cooldown with natural circulation using one steam generator.
- B. Performing a 25°F/hr RCS cooldown with all reactor coolant pumps running.
- C. Performing a 100°F/hr RCS cooldown with natural circulation using all steam generators.
- D. Performing a 100°F/hr RCS cooldown with one reactor coolant pump running.

ANSWER: B.

TOPIC: 193008
KNOWLEDGE: K1.16 [2.4/2.6]
QID: P391 (B1989)

Refer to the drawing of a fuel rod and adjacent coolant flow channel (see figure below).

With a nuclear power plant operating at steady-state 100 percent reactor power at the beginning of a fuel cycle, which one of the following has the greater temperature difference?

- A. Fuel pellet centerline-to-pellet surface
- B. Fuel pellet surface-to-cladding gap
- C. Zircaloy cladding
- D. Coolant laminar layer

ANSWER: A.

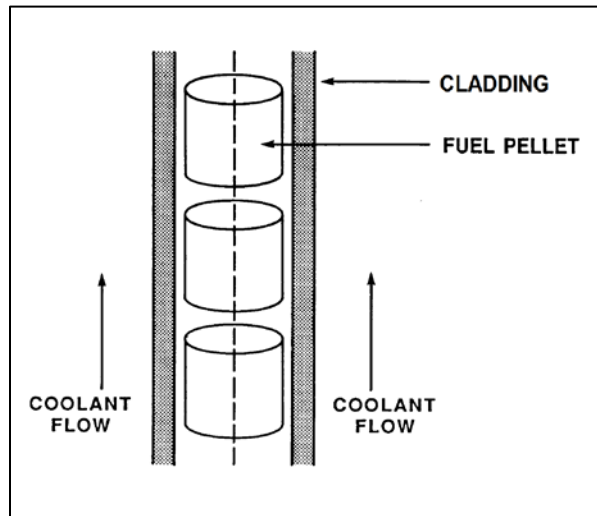

TOPIC: 193008
KNOWLEDGE: K1.17 [2.9/3.2]
QID: P692

During a plant cooldown and depressurization with forced circulation, reactor coolant system (RCS) loop flow indications and reactor coolant pump (RCP) motor current indications become erratic. These abnormal indications are most likely caused by...

- A. RCP cavitation.
- B. RCP runout.
- C. RCS loop water hammer.
- D. RCS hot leg saturation.

ANSWER: A.

TOPIC: 193008
KNOWLEDGE: K1.18 [2.3/2.5]
QID: P1790 (B1789)

Single-phase coolant flow resistance in a reactor core is directly proportional to the square of coolant _____; and inversely proportional to _____.

- A. velocity; fuel assembly length
- B. temperature; fuel assembly length
- C. velocity; coolant channel cross-sectional area
- D. temperature; coolant channel cross-sectional area

ANSWER: C.

TOPIC: 193008
KNOWLEDGE: K1.18 [2.3/2.5]
QID: P5446 (B5445)

Refer to the drawing of a section of pipe that contains flowing subcooled water (see figure below).

Given:

- Pressure at P_1 is 24 psig.
- Pressure at P_2 is 16 psig.
- Pressure change due to change in velocity is 2 psig.
- Pressure change due to change in elevation is 10 psig.

The pressure decrease due to friction head loss between P_1 and P_2 is _____; and the direction of flow is from _____.

- A. 2 psig; left to right
- B. 2 psig; right to left
- C. 4 psig; left to right
- D. 4 psig; right to left

ANSWER: D.

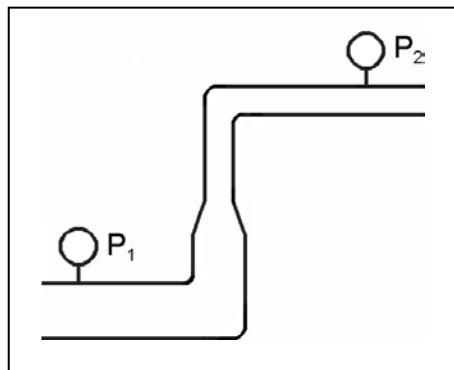

TOPIC: 193008
KNOWLEDGE: K1.18 [2.3/2.5]
QID: P5847 (B5845)

Refer to the drawing of a section of pipe that contains flowing subcooled water (see figure below).

Given:

- Pressure at P_1 is 26 psig.
- Pressure at P_2 is 34 psig.
- Pressure change due to change in velocity is 2 psig.
- Pressure change due to change in elevation is 8 psig.

The pressure decrease due to friction head loss between P_1 and P_2 is _____; and the direction of flow is from _____.

- A. 2 psig; left to right
- B. 2 psig; right to left
- C. 4 psig; left to right
- D. 4 psig; right to left

ANSWER: A.

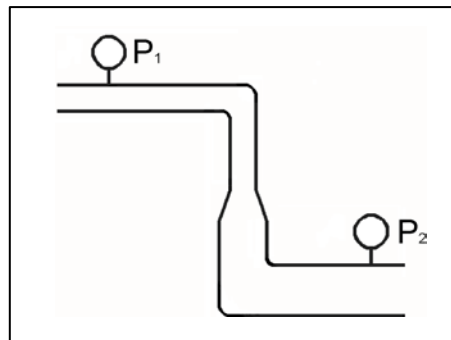

TOPIC: 193008
KNOWLEDGE: K1.18 [2.3/2.5]
QID: P6648 (B6646)

Refer to the drawing of a section of pipe that contains flowing subcooled water. (See figure below).

Given:

- Pressure at P_1 is 30 psig.
- Pressure at P_2 is 32 psig.
- Pressure change due to change in velocity is 2 psig.
- Pressure change due to change in elevation is 2 psig.

The pressure decrease due to friction head loss between P_1 and P_2 is _____; and the direction of flow is from _____.

- A. 2 psig; left to right
- B. 2 psig; right to left
- C. 6 psig; left to right
- D. 6 psig; right to left

ANSWER: B.

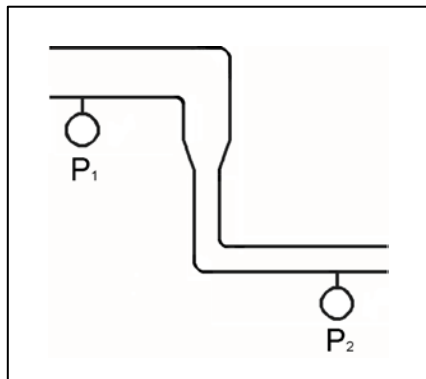

TOPIC: 193008
KNOWLEDGE: K1.18 [2.3/2.5]
QID: P7048 (B7046)

Refer to the drawing of a section of pipe that contains flowing subcooled water (see figure below).

Given:

- Pressure at P_1 is 34 psig.
- Pressure at P_2 is 20 psig.
- Pressure change due to change in velocity is 2 psig.
- Pressure change due to change in elevation is 8 psig.

The pressure decrease due to friction head loss between P_1 and P_2 is _____; and the direction of flow is from _____.

- A. 2 psig; left to right
- B. 2 psig; right to left
- C. 4 psig; left to right
- D. 4 psig; right to left

ANSWER: D.

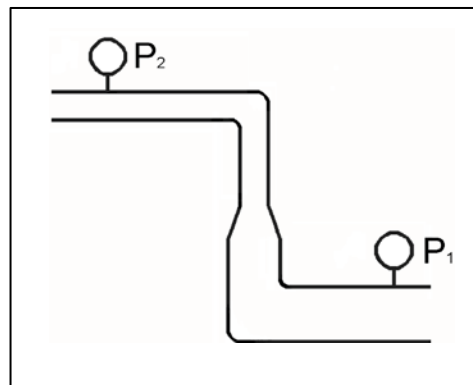

TOPIC: 193008
KNOWLEDGE: K1.18 [2.3/2.5]
QID: P7680 (B7680)

Refer to the drawing of a section of pipe that contains flowing subcooled water (see figure below).

Given:

- The pressure at P_1 is 20 psig.
- The pressure at P_2 is 20 psig.
- The pressure change caused by the change in velocity is 2 psig.
- The pressure change caused by the change in elevation is 8 psig.

The pressure decrease due to friction head loss between P_1 and P_2 is _____; and the direction of flow is from _____.

- A. 6 psig; left to right
- B. 6 psig; right to left
- C. 10 psig; left to right
- D. 10 psig; right to left

ANSWER: B.

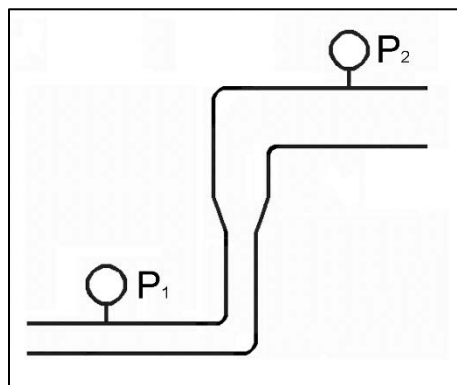

TOPIC: 193008
KNOWLEDGE: K1.19 [2.5/2.8]
QID: P1192

A reactor is producing 3,400 MW of thermal output with a reactor vessel differential temperature (ΔT) of 60°F and a reactor vessel mass flow rate of 1.4×10^8 lbm/hr. If core ΔT is 63.6°F, what is core bypass mass flow rate? (Assume bypass flow ΔT equals 0°F.)

- A. 7.92×10^6 lbm/hr
- B. 8.40×10^6 lbm/hr
- C. 1.26×10^8 lbm/hr
- D. 1.32×10^8 lbm/hr

ANSWER: A.

TOPIC: 193008
KNOWLEDGE: K1.19 [2.5/2.8]
QID: P1886

A reactor is producing 3,400 MW of thermal output with a reactor vessel differential temperature (ΔT) of 60°F and a reactor vessel mass flow rate of 1.0×10^8 lbm/hr. If core ΔT is 63.6°F, what is core bypass mass flow rate? (Assume bypass flow ΔT equals 0°F.)

- A. 5.66×10^6 lbm/hr
- B. 8.40×10^6 lbm/hr
- C. 3.60×10^7 lbm/hr
- D. 9.43×10^7 lbm/hr

ANSWER: A.

TOPIC: 193008
KNOWLEDGE: K1.19 [2.5/2.8]
QID: P2291

A reactor is producing 3,400 MW of thermal output with a reactor vessel differential temperature (ΔT) of 60°F and a reactor vessel mass flow rate of 1.1×10^8 lbm/hr. If core ΔT is 63.6°F, what is core bypass mass flow rate? (Assume bypass flow ΔT equals 0°F.)

- A. 5.66×10^6 lbm/hr
- B. 6.23×10^6 lbm/hr
- C. 5.66×10^7 lbm/hr
- D. 6.23×10^7 lbm/hr

ANSWER: B.

TOPIC: 193008
KNOWLEDGE: K1.20 [2.9/2.9]
QID: P590

Adequate core bypass flow is needed to...

- A. cool the excore nuclear instrument detectors.
- B. provide reactor coolant pump minimum flow requirements.
- C. prevent stratification of reactor coolant inside the reactor vessel lower head.
- D. equalize the temperatures between the reactor vessel and the reactor vessel upper head.

ANSWER: D.

TOPIC: 193008
KNOWLEDGE: K1.20 [2.9/2.9]
QID: P1391

Which one of the following describes a function of core bypass flow?

- A. Provides a means of measuring core flow rate.
- B. Prevents boron precipitation in the core baffle area.
- C. Prevents excessive reactor vessel wall differential temperature.
- D. Provides cooling to various reactor vessel internal components.

ANSWER: D.

TOPIC: 193008
KNOWLEDGE: K1.20 [2.9/2.9]
QID: P1488

Which one of the following is a function of core bypass flow?

- A. Provides mixing of coolant in the reactor vessel head.
- B. Provides even coolant flow distribution through the fuel.
- C. Ensures natural circulation will be initiated when forced circulation is lost.
- D. Ensures core exit thermocouple readings represent average fuel temperatures.

ANSWER: A.

TOPIC: 193008
KNOWLEDGE: K1.21 [3.9/4.2]
QID: P91

Maximizing the elevation difference between the core thermal center and the steam generator thermal center and minimizing flow restrictions in the reactor coolant system (RCS) piping are features of nuclear power plant designs that...

- A. minimize the RCS volume.
- B. maximize the RCS flow rate during forced circulation.
- C. ensure a maximum RCS loop transit time.
- D. ensure RCS natural circulation flow can be established.

ANSWER: D.

TOPIC: 193008
KNOWLEDGE: K1.21 [3.9/4.2]
QID: P292

Which one of the following must exist for natural circulation flow to occur?

- A. The heat source must be larger than the heat sink.
- B. The heat source must be located higher than the heat sink.
- C. The heat sink must be larger than the heat source.
- D. The heat sink must be located higher than the heat source.

ANSWER: D.

TOPIC: 193008
KNOWLEDGE: K1.21 [3.9/4.2]
QID: P893

The driving head for natural circulation flow through the core is developed by differences in _____ between the hot leg and the cold leg.

- A. water density
- B. water volume
- C. pipe diameter
- D. piping length

ANSWER: A.

TOPIC: 193008
KNOWLEDGE: K1.21 [3.9/4.2]
QID: P1387

If the steam generator thermal centers were at the same elevation as the reactor core thermal center, natural circulation flow in the reactor coolant system would...

- A. not occur.
- B. not be affected.
- C. be greater than if they were at different elevations.
- D. flow in the reverse direction.

ANSWER: A.

TOPIC: 193008
KNOWLEDGE: K1.21 [3.9/4.2]
QID: P1393

A reactor is shut down with natural circulation core cooling. Decay heat generation is equivalent to 1.0 percent of rated thermal power. Stable natural circulation mass flow rate is 1,000 gpm.

When decay heat generation decreases to 0.5 percent of rated thermal power, stable natural circulation flow rate will be approximately...

- A. 125 gpm.
- B. 250 gpm.
- C. 707 gpm.
- D. 794 gpm.

ANSWER: D.

TOPIC: 193008
KNOWLEDGE: K1.21 [3.9/4.2]
QID: P1692

A reactor is shut down with natural circulation core cooling. Decay heat generation is equivalent to 1.0 percent of rated thermal power. Core differential temperature (ΔT) has stabilized at 16°F.

When decay heat generation decreases to 0.5 percent of rated thermal power, core ΔT will be approximately...

- A. 2°F.
- B. 4°F.
- C. 8°F.
- D. 10°F.

ANSWER: D.

TOPIC: 193008
KNOWLEDGE: K1.21 [3.9/4.2]
QID: P1887

Sustained natural circulation requires that the heat sink is _____ in elevation than the heat source and that there is a _____ difference between the heat sink and the heat source.

- A. lower; pressure
- B. lower; temperature
- C. higher; pressure
- D. higher; temperature

ANSWER: D.

TOPIC: 193008
KNOWLEDGE: K1.21 [3.9/4.2]
QID: P1989 (B2386)

Which one of the following conditions must occur to sustain natural convection in a fluid system?

- A. Subcooling of the fluid.
- B. A phase change in the fluid.
- C. A density change in the fluid.
- D. Radiative heat transfer to the fluid.

ANSWER: C.

TOPIC: 193008
KNOWLEDGE: K1.21 [3.9/4.2]
QID: P2092

A reactor is shut down with natural circulation core cooling. Decay heat generation is equivalent to 1.0 percent of rated thermal power. Core differential temperature (ΔT) has stabilized at 16°F.

When decay heat generation decreases to 0.333 percent of rated thermal power, core ΔT will be approximately...

- A. 2°F.
- B. 4°F.
- C. 8°F.
- D. 10°F.

ANSWER: C.

TOPIC: 193008
KNOWLEDGE: K1.21 [3.9/4.2]
QID: P2392

A reactor is shut down with natural circulation core cooling. Decay heat generation is equivalent to 1.0 percent of rated thermal power. Core differential temperature (ΔT) has stabilized at 13°F.

When decay heat generation decreases to 0.5 percent of rated thermal power, core ΔT will be approximately...

- A. 4°F.
- B. 6°F.
- C. 8°F.
- D. 10°F.

ANSWER: C.

TOPIC: 193008
KNOWLEDGE: K1.21 [3.9/4.2]
QID: P2491

A reactor is shut down with natural circulation core cooling. Decay heat generation is equivalent to 1.0 percent of rated thermal power. Stable natural circulation flow rate is 800 gpm.

When decay heat generation decreases to 0.5 percent of rated thermal power, stable natural circulation flow rate will be approximately...

- A. 400 gpm.
- B. 565 gpm.
- C. 635 gpm.
- D. 696 gpm.

ANSWER: C.

TOPIC: 193008
KNOWLEDGE: K1.21 [3.9/4.2]
QID: P7447

Sustained natural circulation requires that the heat source is _____ in elevation than the heat sink; and that there is a _____ difference between the heat source and the heat sink.

- A. lower; phase
- B. lower; temperature
- C. higher; phase
- D. higher; temperature

ANSWER: B.

TOPIC: 193008
KNOWLEDGE: K1.22 [4.2/4.2]
QID: P1492

A nuclear power plant was operating at steady-state 100 percent power when a loss of offsite power occurred, resulting in a reactor trip and a loss of forced reactor coolant circulation. Thirty minutes later, reactor coolant system (RCS) hot leg temperature is greater than cold leg temperature and steam generator (SG) levels are stable.

Which one of the following combinations of parameter trends, observed 30 minutes after the trip, indicates that natural circulation is occurring? (CET = core exit thermocouple)

	<u>RCS Hot Leg Temperature</u>	<u>RCS Cold Leg Temperature</u>	<u>SG Pressures</u>	<u>RCS CET Subcooling</u>
A.	Decreasing	Stable	Stable	Increasing
B.	Increasing	Decreasing	Increasing	Decreasing
C.	Decreasing	Decreasing	Decreasing	Decreasing
D.	Increasing	Increasing	Decreasing	Increasing

ANSWER: A.

TOPIC: 193008
KNOWLEDGE: K1.22 [4.2/4.2]
QID: P1791

A nuclear power plant was operating at steady-state 100 percent power when a loss of offsite power occurred, resulting in a reactor trip and a loss of forced reactor coolant circulation. Two hours later, reactor coolant system (RCS) hot leg temperature is greater than cold leg temperature and steam generator (SG) levels are stable.

Which one of the following combinations of parameter trends, observed two hours after the trip, indicates that natural circulation is not occurring? (CET = core exit thermocouples)

	<u>RCS Hot Leg Temperature</u>	<u>RCS Cold Leg Temperature</u>	<u>SG Pressures</u>	<u>RCS CET Subcooling</u>
A.	Stable	Decreasing	Decreasing	Stable
B.	Stable	Stable	Decreasing	Decreasing
C.	Decreasing	Decreasing	Decreasing	Increasing
D.	Decreasing	Stable	Stable	Increasing

ANSWER: B.

TOPIC: 193008
KNOWLEDGE: K1.22 [4.2/4.2]
QID: P7670

A reactor had been operating at 100 percent power for 3 months when a loss of offsite power occurred, causing a reactor trip and a loss of forced reactor coolant flow. If forced reactor coolant flow is not restored, which one of the following describes the relationship between reactor coolant hot leg and cold leg temperatures one hour after the reactor trip?

- A. Hot leg temperature will be greater than cold leg temperature because natural circulation cooling flow occurs in the same direction as forced reactor coolant flow.
- B. Hot leg temperature will be less than cold leg temperature because natural circulation cooling flow occurs in the opposite direction as forced reactor coolant flow.
- C. Hot leg temperature will be approximately the same as cold leg temperature because only the density of the reactor coolant changes during natural circulation cooling.
- D. Hot leg temperature will be approximately the same as cold leg temperature because the reactor does not produce a significant amount of heat one hour after a reactor trip.

ANSWER: A.

TOPIC: 193008
KNOWLEDGE: K1.23 [3.9/4.1]
QID: P92

A reactor is shut down at normal operating temperature and pressure with all reactor coolant pumps stopped. Stable natural circulation cooling is in progress with a minimum of 50°F subcooling. Which one of the following, if increased, will not affect natural circulation flow rate?

- A. Reactor coolant pressure
- B. Time after reactor trip
- C. Feedwater flow rate
- D. Steam generator pressure

ANSWER: A.

TOPIC: 193008
KNOWLEDGE: K1.23 [3.9/4.1]
QID: P293

Fully-developed natural circulation flow rate will be greatest when...

- A. all reactor coolant pumps stop sequentially within 1 hour after a reactor trip.
- B. all reactor coolant pumps stop at the same time as the reactor trip.
- C. all reactor coolant pumps run for 1 hour after a reactor trip, and then stop.
- D. only one reactor coolant pump runs for 1 hour after a reactor trip, and then stops.

ANSWER: B.

TOPIC: 193008
KNOWLEDGE: K1.23 [3.9/4.1]
QID: P392

Natural circulation flow can be enhanced by...

- A. increasing the elevation of the heat source to equal that of the heat sink.
- B. increasing the temperature difference between the heat source and the heat sink.
- C. decreasing the temperature difference between the heat source and the heat sink.
- D. decreasing the elevation difference between the heat source and the heat sink.

ANSWER: B.

TOPIC: 193008
KNOWLEDGE: K1.23 [3.9/4.1]
QID: P1493

Which one of the following will enhance natural circulation flow in the reactor coolant system?

- A. Pressurizer level is decreased.
- B. Steam generator level is increased.
- C. Pressurizer pressure is decreased.
- D. Steam generator pressure is increased.

ANSWER: B.

TOPIC: 193008
KNOWLEDGE: K1.23 [3.9/4.1]
QID: P1591

A nuclear power plant was operating at a constant power level for the last two weeks when a loss of offsite power occurred, which caused a reactor trip and a loss of forced reactor coolant flow. Natural circulation reactor coolant flow developed and stabilized 30 minutes after the trip.

Which one of the following combinations of initial reactor power and post-trip steam generator pressure will result in the highest stable natural circulation flow rate 30 minutes after the trip?

	<u>Initial Reactor Power</u>	<u>Post-trip Steam Generator Pressure</u>
A.	100 percent	1,100 psia
B.	25 percent	1,100 psia
C.	100 percent	1,000 psia
D.	25 percent	1,000 psia

ANSWER: C.

TOPIC: 193008
KNOWLEDGE: K1.23 [3.9/4.1]
QID: P1985

A nuclear power plant was operating at a constant power level for the last two weeks when a loss of offsite power occurred, which caused a reactor trip and a loss of forced reactor coolant flow. Natural circulation reactor coolant flow developed and stabilized 30 minutes after the trip.

Which one of the following combinations of initial reactor power and post-trip steam generator pressure will result in the lowest stable natural circulation flow rate 30 minutes after the trip?

	<u>Initial Reactor Power</u>	<u>Post-trip Steam Generator Pressure</u>
A.	100 percent	1,100 psia
B.	25 percent	1,100 psia
C.	100 percent	1,000 psia
D.	25 percent	1,000 psia

ANSWER: B.

TOPIC: 193008
KNOWLEDGE: K1.23 [3.9/4.1]
QID: P2492

A nuclear power plant was operating at steady-state 100 percent power when a loss of offsite power occurred, which caused a reactor trip and a complete loss of forced reactor coolant flow. Natural circulation reactor coolant flow developed and stabilized approximately 30 minutes after the trip.

Which one of the following combinations of reactor power history and post-trip steam generator pressure will result in the highest stable natural circulation flow rate?

	<u>Days At Full Power</u>	<u>Post-trip Steam Generator Pressure</u>
A.	12	1,100 psia
B.	100	1,100 psia
C.	12	1,000 psia
D.	100	1,000 psia

ANSWER: D.

TOPIC: 193008
KNOWLEDGE: K1.23 [3.9/4.1]
QID: P3292

A few minutes ago, a nuclear power plant experienced a loss of offsite power that caused a reactor trip and a loss of all reactor coolant pumps. Natural circulation flow is currently developing in the reactor coolant system (RCS).

Which one of the following operator actions will promote the development of natural circulation in the RCS?

- A. Establish and maintain saturation conditions in the RCS.
- B. Establish and maintain a steam bubble in the reactor vessel.
- C. Establish and maintain steam generator pressure above RCS pressure.
- D. Establish and maintain steam generator water level high in the normal operating range.

ANSWER: D.

TOPIC: 193008
KNOWLEDGE: K1.23 [3.9/4.1]
QID: P7750

A nuclear power plant was operating at steady-state 100 percent power when a sustained loss of offsite power occurred, which caused a reactor trip and a complete loss of forced reactor coolant flow. Which one of the following combinations of reactor power history and post-trip steam generator pressure will result in the smallest stable natural circulation flow rate?

	<u>Days At 100 Percent Power</u>	<u>Post-trip Steam Generator Pressure</u>
A.	10	1,100 psia
B.	80	1,100 psia
C.	10	900 psia
D.	80	900 psia

ANSWER: A.

TOPIC: 193008
KNOWLEDGE: K1.24 [2.7/3.1]
QID: P592

During the reflux boiling method of core cooling, steam from the reactor core is condensed in the _____ side of a steam generator and flows back into the core via the _____. (Assume the steam generators contain U-tubes.)

- A. hot leg; hot leg
- B. cold leg; hot leg
- C. hot leg; cold leg
- D. cold leg; cold leg

ANSWER: A.

TOPIC: 193008
KNOWLEDGE: K1.24 [2.7/3.1]
QID: P786

Which one of the following describes the method of core heat removal during reflux core cooling following a loss of coolant accident?

- A. Convection with forced coolant flow.
- B. Convection with natural circulation coolant flow.
- C. Conduction with stagnant coolant flow.
- D. Radiation with total core voiding.

ANSWER: B.

TOPIC: 193008
KNOWLEDGE: K1.24 [2.7/3.1]
QID: P2692

A nuclear power plant is experiencing natural circulation core cooling following a loss of coolant accident. Which one of the following, when it first occurs, marks the beginning of reflux core cooling? (Assume the steam generators contain U-tubes.)

- A. Reactor core steam production results in two-phase coolant entering the hot legs and being delivered to the steam generators.
- B. Hot leg steam quality is so high that the steam generators cannot fully condense it, and two-phase coolant is returned to the reactor vessel via the cold legs.
- C. Steam condensation in the hot legs is unable to pass completely through the steam generators to enter the cold legs.
- D. The steam generators are no longer able to condense any of the steam contained in the hot legs.

ANSWER: C.

TOPIC: 193008
KNOWLEDGE: K1.25 [3.3/3.4]
QID: P593

A reactor coolant system natural circulation cooldown is in progress with steam release from the steam generator (SG) atmospheric steam relief valves (operated in manual control). If high point voiding interrupts natural circulation, which one of the following will occur? (Assume feedwater flow rate, SG relief valve position, and core decay heat level are constant.)

- A. SG level will increase and SG pressure will increase.
- B. SG level will increase and SG pressure will decrease.
- C. SG level will decrease and SG pressure will increase.
- D. SG level will decrease and SG pressure will decrease.

ANSWER: B.

TOPIC: 193008
KNOWLEDGE: K1.25 [3.3/3.4]
QID: P793

A reactor coolant system natural circulation cooldown is in progress with steam release from the steam generator (SG) atmospheric steam relief valves (operated in manual control). Assume feedwater flow rate, SG relief valve position, and core decay heat level are constant.

If high point voiding interrupts natural circulation, SG levels will gradually _____; and core exit thermocouple indications will gradually _____.

- A. decrease; increase
- B. decrease; decrease
- C. increase; increase
- D. increase; decrease

ANSWER: C.

TOPIC: 193008
KNOWLEDGE: K1.25 [3.3/3.4]
QID: P2093

A reactor coolant system natural circulation cooldown is in progress with steam release from the steam generator (SG) atmospheric steam relief valves (operated in manual control).

If voids interrupt natural circulation, which one of the following will occur? (Assume feedwater flow rate, SG relief valve position, and decay heat level are constant.)

- A. SG pressure will decrease and core exit thermocouple (CET) temperatures will increase.
- B. SG pressure will decrease and CET temperatures will remain constant.
- C. SG pressure will increase and CET temperatures will increase.
- D. SG pressure will increase and CET temperatures will remain constant.

ANSWER: A.

TOPIC: 193008
KNOWLEDGE: K1.25 [3.3/3.4]
QID: P2493

A reactor coolant system natural circulation cooldown is in progress with steam release from the steam generator (SG) atmospheric steam relief valves (operated in manual control). Assume feedwater flow rate, SG relief valve position, and core decay heat level remain constant.

If high point voiding interrupts natural circulation, SG steam flow rate will _____ and core exit thermocouple temperatures will _____.

- A. decrease; increase
- B. decrease; remain constant
- C. increase; increase
- D. increase; remain constant

ANSWER: A.