

TOPIC: 191005  
KNOWLEDGE: K1.01 [2.8/3.1]  
QID: P26

If a reactor coolant pump (RCP) rotor seizes, RCP motor current will \_\_\_\_\_; and if the rotor shears, RCP motor speed will \_\_\_\_\_.

- A. increase, increase
- B. increase, decrease
- C. decrease, increase
- D. decrease, decrease

ANSWER: A.

TOPIC: 191005  
KNOWLEDGE: K1.01 [2.8/3.1]  
QID: P227

A nuclear power plant is operating at steady-state 80 percent power when a reactor coolant pump (RCP) shaft seizes. Which one of the following indications would not accompany the seized shaft?

- A. Reactor coolant system pressure transient.
- B. Decreased flow rate in the associated reactor coolant loop.
- C. Decreased flow rate in the remaining reactor coolant loop(s).
- D. Increased current to the affected RCP with possible breaker trip.

ANSWER: C.

TOPIC: 191005  
KNOWLEDGE: K1.01 [2.8/3.1]  
QID: P327

A nuclear power plant is operating at steady-state 100 percent power when a reactor coolant pump (RCP) malfunction occurs. Thirty seconds after the malfunction, which one of the following can be used by an operator to determine whether the malfunction is a locked RCP rotor or a sheared RCP rotor? (Assume no operator action is taken.)

- A. Reactor trip status
- B. Loop flow indications
- C. RCP ammeter indications
- D. Loop differential temperature indications

ANSWER: C.

TOPIC: 191005  
KNOWLEDGE: K1.01 [2.8/3.1]  
QID: P1127

During a reactor coolant pump (RCP) locked rotor event, RCP motor current will...

- A. increase due to the increased rotor torque.
- B. increase due to the increased counter electromotive force (CEMF) in the stator.
- C. decrease due to the decreased pump flow rate.
- D. decrease due to the increased CEMF in the rotor.

ANSWER: A.

TOPIC: 191005  
KNOWLEDGE: K1.01 [2.8/3.1]  
QID: P1427 (B2626)

A motor-driven cooling water pump is operating normally. How will pump motor current respond if the pump experiences a locked rotor?

- A. Decreases immediately to zero due to breaker trip.
- B. Decreases immediately to no-load motor amps.
- C. Increases immediately to many times running current, then decreases to no-load motor amps.
- D. Increases immediately to many times running current, then decreases to zero upon breaker trip.

ANSWER: D.

TOPIC: 191005  
KNOWLEDGE: K1.01 [2.8/3.1]  
QID: P2127 (B1326)

A cooling water pump is being driven by an AC induction motor. Which one of the following describes how and why pump motor current will change if the pump shaft seizes?

- A. Decreases due to decreased pump flow.
- B. Decreases due to increased counter electromotive force.
- C. Increases due to decreased pump flow.
- D. Increases due to decreased counter electromotive force.

ANSWER: D.

TOPIC: 191005  
KNOWLEDGE: K1.01 [2.8/3.1]  
QID: P3127 (B2826)

A motor-driven centrifugal pump exhibits indications of pump failure while being started in an idle cooling water system. Assuming the pump motor breaker does not trip, which one of the following pairs of indications would be observed if the failure is a locked pump shaft?

- A. Lower than normal running current with zero system flow rate.
- B. Lower than normal running current with a fraction of normal system flow rate.
- C. Excessive duration of peak starting current with zero system flow rate.
- D. Excessive duration of peak starting current with a fraction of normal system flow rate.

ANSWER: C.

TOPIC: 191005  
KNOWLEDGE: K1.01 [2.8/3.1]  
QID: P5914 (B5914)

When a motor-driven centrifugal pump was started, the motor ammeter reading immediately increased to, and stabilized at, many times the normal operating value. Which one of the following describes a possible cause for the ammeter response?

- A. The pump was started with a fully closed discharge valve.
- B. The pump was started with a fully open discharge valve.
- C. The pump shaft seized upon start and did not rotate.
- D. The pump shaft separated from the motor shaft upon start.

ANSWER: C.

TOPIC: 191005  
KNOWLEDGE: K1.02 [2.8/2.9]  
QID: P27

If the generator bearings on a motor-generator set begin to overheat from excessive friction, which one of the following will occur?

- A. Generator current will begin to increase.
- B. Generator windings will begin to heat up.
- C. Motor current will begin to decrease.
- D. Motor windings will begin to heat up.

ANSWER: D.

TOPIC: 191005  
KNOWLEDGE: K1.02 [2.8/2.9]  
QID: P344 (B340)

A thermal overload device for a large motor protects the motor from...

- A. sustained overcurrent by opening the motor breaker or motor line contacts.
- B. sustained overcurrent by opening contacts in the motor windings.
- C. instantaneous overcurrent by opening the motor breaker or motor line contacts.
- D. instantaneous overcurrent by opening contacts in the motor windings.

ANSWER: A.

TOPIC: 191005  
KNOWLEDGE: K1.02 [2.8/2.9]  
QID: P528 (B1927)

Which one of the following will provide the initial motor protection against electrical damage caused by gradual bearing failure?

- A. Thermal overload device
- B. Overcurrent trip relay
- C. Underfrequency relay
- D. Undervoltage device

ANSWER: A.

TOPIC: 191005  
KNOWLEDGE: K1.02 [2.8/2.9]  
QID: P1028 (B1526)

Which one of the following will result from prolonged operation of an AC induction motor with excessively high stator temperatures?

- A. Decreased electrical current demand due to reduced counter electromotive force.
- B. Increased electrical current demand due to reduced counter electromotive force.
- C. Decreased electrical resistance to ground due to breakdown of winding insulation.
- D. Increased electrical resistance to ground due to breakdown of winding insulation.

ANSWER: C.

TOPIC: 191005  
KNOWLEDGE: K1.02 [2.8/2.9]  
QID: P1528 (B1126)

Continuous operation of a motor at rated load with a loss of required cooling to the motor windings will eventually result in...

- A. cavitation of the pumped fluid.
- B. failure of the motor overcurrent protection devices.
- C. breakdown of the motor insulation and electrical grounds.
- D. phase current imbalance in the motor and overspeed trip actuation.

ANSWER: C.

TOPIC: 191005  
KNOWLEDGE: K1.02 [2.8/2.9]  
QID: P2644 (B2242)

Thermal overload devices will provide the first electrical protection for a pump motor in the event of...

- A. a locked rotor upon starting.
- B. an electrical short circuit.
- C. gradual motor bearing damage.
- D. a sheared shaft during operation.

ANSWER: C.

TOPIC: 191005  
KNOWLEDGE: K1.02 [2.8/2.9]  
QID: P2927

Which one of the following trip signals will trip the breaker for an operating motor that experiences a seized rotor?

- A. Undervoltage
- B. Underfrequency
- C. Time-delayed overcurrent
- D. Instantaneous overcurrent

ANSWER: C.

TOPIC: 191005  
KNOWLEDGE: K1.03 [2.7/2.8]  
QID: P115 (B120)

A main generator that is connected to an infinite power grid has the following initial indications:

100 MW  
0 MVAR  
2,900 amps  
20 KV

If main generator field current is reduced slightly, amps will \_\_\_\_\_; and MW will \_\_\_\_\_.

- A. increase; decrease
- B. decrease; decrease
- C. increase; remain the same
- D. decrease; remain the same

ANSWER: C.



TOPIC: 191005  
KNOWLEDGE: K1.03 [2.7/2.8]  
QID: P229

Excessive current will be drawn by an AC induction motor that is operating...

- A. completely unloaded.
- B. at full load.
- C. with open-circuited stator windings.
- D. with short-circuited stator windings.

ANSWER: D.

TOPIC: 191005  
KNOWLEDGE: K1.03 [2.7/2.8]  
QID: P529

A main generator that is connected to an infinite power grid has the following indications:

500 MW  
300 MVAR (out)  
2,800 amps

If main generator field current is reduced slightly, amps will \_\_\_\_\_; and MW will \_\_\_\_\_.

- A. increase; decrease
- B. increase; remain the same
- C. decrease; decrease
- D. decrease; remain the same

ANSWER: D.

TOPIC: 191005  
KNOWLEDGE: K1.03 [2.7/2.8]  
QID: P928

A main generator is connected to an infinite power grid. If the voltage supplied to the generator field is slowly and continuously decreased, the generator will experience high current due to... (Assume no generator protective actuations occur.)

- A. excessive generator MW.
- B. excessive generator MVAR out.
- C. excessive generator MVAR in.
- D. generator reverse power.

ANSWER: C.

TOPIC: 191005  
KNOWLEDGE: K1.03 [2.7/2.8]  
QID: P1128 (B2228)

An AC generator is supplying an isolated electrical system with a power factor of 1.0. If generator voltage is held constant while real load (KW) increases, the current supplied by the generator will increase in direct proportion to the \_\_\_\_\_ of the change in real load. (Assume the generator power factor remains constant at 1.0.)

- A. cube
- B. square
- C. amount
- D. square root

ANSWER: C.

TOPIC: 191005  
KNOWLEDGE: K1.03 [2.7/2.8]  
QID: P1428 (B1830)

A main generator that is connected to an infinite power grid has the following indications:

600 MW  
100 MVAR (in)  
13,800 amps  
25 KV

If main generator excitation current is increased slightly, amps will initially \_\_\_\_\_; and MW will initially \_\_\_\_\_.

- A. decrease; increase
- B. increase; increase
- C. decrease; remain the same
- D. increase; remain the same

ANSWER: C.

TOPIC: 191005  
KNOWLEDGE: K1.03 [2.7/2.8]  
QID: P1728 (B1729)

A main generator that is connected to an infinite power grid has the following indications:

600 MW  
100 MVAR (in)  
13,800 amps  
25 KV

If main generator excitation current is decreased slightly, amps will \_\_\_\_\_; and MVAR will \_\_\_\_\_.

- A. decrease; increase
- B. increase; increase
- C. decrease; decrease
- D. increase; decrease

ANSWER: B.

TOPIC: 191005  
KNOWLEDGE: K1.03 [2.7/2.8]  
QID: P1928 (B226)

A main generator is connected to an infinite power grid. Which one of the following conditions will exist if the generator is operating underexcited?

- A. Negative MVAR (VARs in) with a leading power factor
- B. Positive MVAR (VARs out) with a leading power factor
- C. Positive MVAR (VARs out) with a lagging power factor
- D. Negative MVAR (VARs in) with a lagging power factor

ANSWER: A.

TOPIC: 191005  
KNOWLEDGE: K1.03 [2.7/2.8]  
QID: P2027 (B2028)

A diesel generator (DG) is supplying both KW and KVAR to an electrical bus that is connected to an infinite power grid. Assuming DG and bus voltage do not change, if the DG voltage regulator setpoint is increased slightly, DG KW will \_\_\_\_\_; and DG amps will \_\_\_\_\_.

- A. remain the same; increase
- B. remain the same; remain the same
- C. increase; increase
- D. increase; remain the same

ANSWER: A.

TOPIC: 191005  
KNOWLEDGE: K1.03 [2.7/2.8]  
QID: P2228

A diesel generator (DG) is supplying an electrical bus that is connected to an infinite power grid. Assuming DG terminal voltage and bus frequency do not change, if the DG governor setpoint is increased from 60.0 Hz to 60.1 Hz, DG KVAR load will \_\_\_\_\_; and DG amps will \_\_\_\_\_.

- A. increase; increase
- B. increase; remain the same
- C. remain the same; increase
- D. remain the same; remain the same

ANSWER: C.

TOPIC: 191005  
KNOWLEDGE: K1.03 [2.7/2.8]  
QID: P2328 (B2330)

A main generator that is connected to an infinite power grid has the following indications:

600 MW  
100 MVAR (out)  
13,800 amps  
25 KV

If main generator field current is decreased, amps will initially \_\_\_\_\_; and MVAR will initially \_\_\_\_\_.

- A. decrease; increase
- B. increase; increase
- C. decrease; decrease
- D. increase; decrease

ANSWER: C.

TOPIC: 191005  
KNOWLEDGE: K1.03 [2.7/2.8]  
QID: P2528 (B2530)

A diesel generator (DG) is supplying both KW and KVAR to an electrical bus that is connected to an infinite power grid. Assuming bus voltage does not change, if the DG voltage regulator setpoint is decreased slightly, DG KW will \_\_\_\_\_; and DG amps will \_\_\_\_\_.

- A. remain the same; decrease
- B. remain the same; remain the same
- C. decrease; decrease
- D. decrease; remain the same

ANSWER: A.

TOPIC: 191005  
KNOWLEDGE: K1.03 [2.7/2.8]  
QID: P2628 (B1532)

A main generator that is connected to an infinite power grid has the following indications:

100 MW  
0 MVAR  
2,900 amps  
20 KV

If main generator excitation is increased, amps will \_\_\_\_\_; and MW will \_\_\_\_\_.

- A. remain the same; increase
- B. remain the same; remain the same
- C. increase; increase
- D. increase; remain the same

ANSWER: D.

TOPIC: 191005  
KNOWLEDGE: K1.03 [2.7/2.8]  
QID: P2728 (B2729)

A main generator is supplying power to an infinite power grid. If the generator field current is slowly and continuously increased, the generator will experience high current due to: (Assume no generator protective actuations occur.)

- A. generator reverse power.
- B. excessive generator MW.
- C. excessive generator MVAR in.
- D. excessive generator MVAR out.

ANSWER: D

TOPIC: 191005  
KNOWLEDGE: K1.03 [2.7/2.8]  
QID: P2838 (B3543)

Two identical 1,000 MW generators are operating in parallel supplying the same isolated electrical bus. The generator output breakers provide identical protection for the generators. Generator A and B output indications are as follows:

<u>Generator A</u>	<u>Generator B</u>
22 KV	22 KV
60.2 Hertz	60.2 Hertz
800 MW	800 MW
50 MVAR (out)	25 MVAR (in)

A malfunction causes the voltage regulator for generator B to slowly and continuously increase the terminal voltage for generator B. If no operator action is taken, generator B output current will...

- A. increase continuously until the output breaker for generator A trips on overcurrent.
- B. increase continuously until the output breaker for generator B trips on overcurrent.
- C. initially decrease, and then increase until the output breaker for generator A trips on overcurrent.
- D. initially decrease, and then increase until the output breaker for generator B trips on overcurrent.

ANSWER: D.



TOPIC: 191005  
KNOWLEDGE: K1.03 [2.7/2.8]  
QID: P3229 (B3227)

Refer to the partial drawing of two identical radial-flow centrifugal pumps in a cooling water system (see figure below).

The cooling water system is being returned to service following maintenance on the pumps. Each pump is driven by an identical three-phase AC induction motor.

Pump A was started five minutes ago to initiate flow in the cooling water system. Pump B is about to be started.

When pump B is started, which one of the following would cause the ammeter for pump B to remain off-scale high for several seconds longer than usual before stabilizing at a normal running current indication?

- A. The pump packing was removed and not reinstalled.
- B. The pump was initially rotating in the reverse direction.
- C. Two phases of the motor windings were electrically switched.
- D. The coupling between the motor and the pump was removed and not reinstalled.

ANSWER: B.

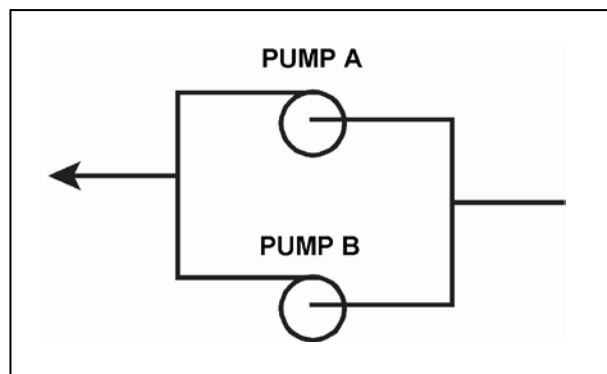

TOPIC: 191005  
KNOWLEDGE: K1.03 [2.7/2.8]  
QID: P3629 (B3629)

A main turbine-generator is operating in parallel with an infinite power grid. If the turbine control valves (or throttle valves) slowly fail open, the generator will experience high current primarily due to... (Assume no generator protective actuations occur.)

- A. excessive generator MW.
- B. excessive generator VARs out.
- C. excessive generator VARs in.
- D. generator reverse power.

ANSWER: A.

TOPIC: 191005  
KNOWLEDGE: K1.03 [2.7/2.8]  
QID: P4115 (B4115)

A main generator is operating and connected to an infinite power grid. Elevated main generator winding temperature requires a reduction in reactive load from 200 MVAR (out) to 150 MVAR (out). To accomplish the reactive load reduction, the operator must \_\_\_\_\_ the generator field current; when generator reactive load equals 150 MVAR (out) the generator power factor will be \_\_\_\_\_ than the initial power factor.

- A. increase; larger
- B. increase; smaller
- C. decrease; larger
- D. decrease; smaller

ANSWER: C.

TOPIC: 191005  
KNOWLEDGE: K1.03 [2.7/2.8]  
QID: P4315

A main generator that is connected to an infinite power grid has the following indications:

22 KV  
60 Hertz  
575 MW  
100 MVAR (in)

Which one of the following contains a combination of manual adjustments to the main generator voltage regulator and speed control setpoints such that each adjustment will initially result in an increase in main generator amps?

- |    | <u>Voltage<br/>Setpoint</u> | <u>Speed<br/>Setpoint</u> |
|----|-----------------------------|---------------------------|
| A. | Increase                    | Increase                  |
| B. | Increase                    | Decrease                  |
| C. | Decrease                    | Increase                  |
| D. | Decrease                    | Decrease                  |

ANSWER: C.

TOPIC: 191005  
KNOWLEDGE: K1.03 [2.7/2.8]  
QID: P4714 (B4714)

A nuclear power plant startup is in progress. The main generator has just been connected to the power grid with the following generator indications:

20 KV  
288 amps  
10 MW  
0 MVAR

The operator suspects the main generator is operating under reverse power conditions and attempts to increase generator load (MW) normally. If the main generator is operating under reverse power conditions when the operator attempts to increase generator load, generator MW will initially \_\_\_\_\_; and generator amps will initially \_\_\_\_\_.

- A. decrease; decrease
- B. decrease; increase
- C. increase; decrease
- D. increase; increase

ANSWER: A.

TOPIC: 191005  
KNOWLEDGE: K1.03 [2.7/2.8]  
QID: P4814 (B4815)

A main generator is connected to an infinite power grid with the following generator output parameters:

22 KV  
60 Hertz  
575 MW  
100 MVAR (in)

Which one of the following contains a combination of manual adjustments to the main generator voltage regulator and speed control setpoints such that each adjustment will initially result in a decrease in main generator amps?

- |    | <u>Voltage Setpoint</u> | <u>Speed Setpoint</u> |
|----|-------------------------|-----------------------|
| A. | Increase                | Increase              |
| B. | Increase                | Decrease              |
| C. | Decrease                | Increase              |
| D. | Decrease                | Decrease              |

ANSWER: B.

TOPIC: 191005  
KNOWLEDGE: K1.03 [2.7/2.8]  
QID: P5014

A main generator is connected to an infinite power grid with the following initial generator parameters:

22 KV  
60 Hertz  
600 MW  
100 MVAR (out)

Which one of the following contains a combination of manual adjustments to the main generator voltage regulator and speed control setpoints such that each adjustment will initially result in an increase in main generator amps?

- |    | <u>Voltage<br/>Setpoint</u> | <u>Speed<br/>Setpoint</u> |
|----|-----------------------------|---------------------------|
| A. | Increase                    | Increase                  |
| B. | Increase                    | Decrease                  |
| C. | Decrease                    | Increase                  |
| D. | Decrease                    | Decrease                  |

ANSWER: A.

TOPIC: 191005  
KNOWLEDGE: K1.03 [2.7/2.8]  
QID: P5414 (B5415)

A main generator is connected to an infinite power grid. Which one of the following pairs of main generator output parameters places the generator in the closest proximity to slipping a pole.

- A. 800 MW; 200 MVAR (in)
- B. 800 MW; 600 MVAR (in)
- C. 400 MW; 200 MVAR (out)
- D. 400 MW; 600 MVAR (out)

ANSWER: B.

TOPIC: 191005  
KNOWLEDGE: K1.03 [2.7/2.8]  
QID: P5514

A main generator is connected to an infinite power grid with the following initial generator parameters:

22 KV  
60 Hertz  
600 MW  
100 MVAR (out)

Which one of the following contains a combination of manual adjustments to the main generator voltage regulator and speed control setpoints such that each adjustment will initially result in a decrease in main generator amps?

- |    | <u>Voltage<br/>Setpoint</u> | <u>Speed<br/>Setpoint</u> |
|----|-----------------------------|---------------------------|
| A. | Increase                    | Increase                  |
| B. | Increase                    | Decrease                  |
| C. | Decrease                    | Increase                  |
| D. | Decrease                    | Decrease                  |

ANSWER: D.



TOPIC: 191005  
KNOWLEDGE: K1.03 [2.7/2.8]  
QID: P6014 (B6014)

During a surveillance test, a 4,000 KW diesel generator (DG) and a 1,000 MW main generator (MG) at a nuclear power plant are connected to the same power grid.

The following stable generator output conditions exist:

<u>Diesel Generator</u>	<u>Main Generator</u>
700 KW	800 MW
200 KVAR (out)	100 MVAR (out)

A malfunction then occurs, causing the voltage regulator for the MG to slowly and continuously increase the MG field current. If no operator action is taken, the DG output current will \_\_\_\_\_ until a breaker trip separates the generators.

- A. remain about the same
- B. increase continuously
- C. initially increase, and then decrease
- D. initially decrease, and then increase

ANSWER: D.

TOPIC: 191005  
KNOWLEDGE: K1.03 [2.7/2.8]  
QID: P6114 (B6115)

A main generator is connected to an infinite power grid with the following generator output parameters:

22 KV  
60 Hertz  
575 MW  
100 MVAR (in)

Which one of the following contains a combination of minor adjustments to the main generator voltage regulator and speed control setpoints such that each adjustment will cause the main generator to operate at a power factor closer to 1.0? (Assume the generator power factor remains less than 1.0.)

- |    | <u>Voltage<br/>Setpoint</u> | <u>Speed<br/>Setpoint</u> |
|----|-----------------------------|---------------------------|
| A. | Increase                    | Increase                  |
| B. | Increase                    | Decrease                  |
| C. | Decrease                    | Increase                  |
| D. | Decrease                    | Decrease                  |

ANSWER: A.

TOPIC: 191005  
KNOWLEDGE: K1.03 [2.7/2.8]  
QID: P6315 (B6314)

A main turbine-generator is connected to an infinite power grid with the following generator output parameters:

25 KV  
20,000 amps  
830 MW  
248 MVAR (out)

Which one of the following will significantly increase main generator output current without a significant change in main generator real load? (Assume the generator power factor remains less than 1.0.)

- A. Increasing the main turbine speed control setpoint.
- B. Increasing the main generator voltage regulator setpoint.
- C. A 10 percent decrease in power grid electrical loads.
- D. A 10 percent increase in power grid electrical loads.

ANSWER: B

TOPIC: 191005  
KNOWLEDGE: K1.03 [2.7/2.8]  
QID: P6515 (B4315)

A main generator is connected to an infinite power grid with the following generator output parameters:

22 KV  
60 Hertz  
575 MW  
100 MVAR (out)

Which one of the following contains a combination of manual adjustments to the main generator voltage regulator and speed control setpoints such that each adjustment will result in main generator operation at a power factor closer to 1.0? (Assume the generator power factor remains less than 1.0.)

- |    | <u>Voltage<br/>Setpoint</u> | <u>Speed<br/>Setpoint</u> |
|----|-----------------------------|---------------------------|
| A. | Increase                    | Increase                  |
| B. | Increase                    | Decrease                  |
| C. | Decrease                    | Increase                  |
| D. | Decrease                    | Decrease                  |

ANSWER: C.

TOPIC: 191005  
KNOWLEDGE: K1.03 [2.7/2.8]  
QID: P6614 (B6615)

During a surveillance test, a 4,000 KW diesel generator (DG) and a 1,000 MW main generator (MG) at a nuclear power plant are connected to a power grid.

The following stable generator output conditions initially exist:

<u>Diesel Generator</u>	<u>Main Generator</u>
700 KW	800 MW
200 KVAR (out)	100 MVAR (out)

A malfunction then occurs, causing the voltage regulator for the MG to slowly and continuously decrease the MG field current. If no operator action is taken, the DG output current will \_\_\_\_\_ until a breaker trip separates the generators.

- A. increase continuously
- B. decrease continuously
- C. initially increase, and then decrease
- D. initially decrease, and then increase

ANSWER: A.

TOPIC: 191005  
KNOWLEDGE: K1.03 [2.7/2.8]  
QID: P6914 (B6915)

A main generator is connected to an infinite power grid with the following generator output parameters:

100 MW  
0 MVAR  
2,625 amps  
22 KV

If the main generator field current is decreased, main generator amps will initially \_\_\_\_\_; and MW will initially \_\_\_\_\_.

- A. decrease; decrease
- B. increase; decrease
- C. decrease; remain the same
- D. increase; remain the same

ANSWER: D.

TOPIC: 191005  
KNOWLEDGE: K1.03 [2.7/2.8]  
QID: P7615 (B7615)

A 4,000 KW diesel generator (DG) is supplying 2,000 KW to a 4.16 KV emergency bus. The DG governor is in the isochronous mode (no speed droop). The emergency bus is about to be synchronized with, and then connected to, an infinite offsite power grid by closing the emergency bus normal power feeder breaker.

The following stable emergency bus and normal power conditions currently exist:

<u>Emergency Bus (from DG)</u>	<u>Normal Power (from Offsite)</u>
4.16 KV	4.16 KV
60.0 Hz	60.1 Hz

When the emergency bus normal power feeder breaker is closed, the DG will... (Assume no additional operator action.)

- A. transfer KW load to the offsite power grid but remain partially loaded.
- B. transfer KW load to the offsite power grid until the DG is completely unloaded.
- C. acquire KW load from the offsite power grid but remain within its KW load rating.
- D. acquire KW load from the offsite power grid and ultimately exceed its KW load rating.

ANSWER: B.

TOPIC: 191005  
KNOWLEDGE: K1.03 [2.7/2.8]  
K1.04 [2.7/2.8]  
QID: P7635 (B7635)

A radial-flow centrifugal cooling water pump is being powered by a 480 VAC induction motor. If the motor input voltage slowly decreases from 480 VAC to 450 VAC, the pump flow rate will \_\_\_\_\_; and the motor current will \_\_\_\_\_. (Assume the motor does not stall.)

- A. decrease; increase
- B. decrease; decrease
- C. remain the same; increase
- D. remain the same; decrease

ANSWER: A.



TOPIC: 191005  
KNOWLEDGE: K1.03 [2.7/2,8]  
QID: P7644 (B7644)

A main generator is connected to an infinite power grid with the following generator output parameters:

22 KV  
60 Hertz  
575 MW  
100 MVAR (out)

Which one of the following contains a combination of minor adjustments to the main generator voltage regulator and speed control setpoints such that each adjustment will cause the main generator to operate at a power factor farther from 1.0? (Assume the generator power factor remains less than 1.0.)

- |    | <u>Voltage<br/>Setpoint</u> | <u>Speed<br/>Setpoint</u> |
|----|-----------------------------|---------------------------|
| A. | Increase                    | Increase                  |
| B. | Increase                    | Decrease                  |
| C. | Decrease                    | Increase                  |
| D. | Decrease                    | Decrease                  |

ANSWER: B.

TOPIC: 191005  
KNOWLEDGE: K1.03 [2.7/2.8]  
QID: P7684 (B7684)

A main generator is connected to an infinite power grid with the following generator output parameters:

22 KV  
60 Hertz  
975 MW  
200 MVAR (out)

Main generator stator winding temperature is abnormally high. Which one of the following contains a combination of manual adjustments to the main generator speed control and voltage regulator setpoints such that each adjustment will reduce the main generator stator winding temperature? (Assume power factor remains less than 1.0.)

	<u>Speed Setpoint</u>	<u>Voltage Setpoint</u>
A.	Increase	Increase
B.	Increase	Decrease
C.	Decrease	Increase
D.	Decrease	Decrease

ANSWER: D.

TOPIC: 191005  
KNOWLEDGE: K1.03 [2.7/2.8]  
QID: P7695 (B7695)

A 4,000 KW rated diesel generator (DG) is supplying 2,000 KW to a 4.16 KV emergency bus. The DG governor is in the isochronous mode (no speed droop). The emergency bus is about to be synchronized with, and then connected to, an infinite offsite power grid by closing the emergency bus normal power feeder breaker.

The following stable emergency bus and normal power conditions currently exist:

Emergency Bus (from DG)	Normal Power (from Offsite)
4.16 KV	4.16 KV
60.1 Hz	59.9 Hz

When the emergency bus normal power feeder breaker is closed, the DG will... (Assume no additional operator action is taken.)

- A. transfer KW load to the offsite power grid, but remain partially loaded.
- B. transfer KW load to the offsite power grid until the DG is completely unloaded.
- C. acquire KW load from the offsite power grid, but remain within its KW load rating.
- D. acquire KW load from the offsite power grid and ultimately exceed its KW load rating.

ANSWER: D.

TOPIC: 191005  
KNOWLEDGE: K1.03 [2.7/2.8]  
QID: P7724

A fault on the offsite AC electrical distribution system caused a sustained 30 percent voltage reduction on all phases of the onsite three-phase AC electrical distribution system. As a result, several operating three-phase AC induction motors in the plant experienced automatic breaker trips.

Which one of the following could be responsible for the automatic breaker trips?

- A. Excessive motor current leading to breaker trips from thermal overload.
- B. Excessive motor current leading to breaker trips from instantaneous overcurrent.
- C. Insufficient breaker control power leading to breaker trips from trip mechanism malfunctions.
- D. Insufficient breaker control power leading to breaker trips from closing mechanism malfunctions.

ANSWER: A.

TOPIC: 191005  
KNOWLEDGE: K1.04 [2.7/2.8]  
QID: P28

If the speed of a centrifugal pump is increased to double pump flow rate, pump motor current will...

- A. remain constant.
- B. increase two-fold (double).
- C. increase four-fold.
- D. increase eight-fold.

ANSWER: D.

TOPIC: 191005  
KNOWLEDGE: K1.04 [2.7/2.8]  
QID: P120

A motor-driven centrifugal pump is operating with the following parameters:

Pump speed = 1,800 rpm  
Pump head = 100 psid  
Motor current = 10 amps

What will be the approximate value of pump head if pump speed is increased such that the motor draws 640 amps?

- A. 400 psid
- B. 800 psid
- C. 1,200 psid
- D. 1,600 psid

ANSWER: D.

TOPIC: 191005  
KNOWLEDGE: K1.04 [2.7/2.8]  
QID: P228 (B227)

A motor-driven centrifugal pump is operating with a flow rate of 3,000 gpm and a current requirement of 200 amps. If the pump speed is reduced such that the flow rate is 2,000 gpm, what is the final current requirement at the new lower speed? (Assume a constant motor voltage.)

- A. 59 amps
- B. 89 amps
- C. 133 amps
- D. 150 amps

ANSWER: A.

TOPIC: 191005  
KNOWLEDGE: K1.04 [2.7/2.8]  
QID: P328 (B326)

A motor-driven centrifugal pump is operating with the following parameters:

Speed = 1,800 rpm  
Motor current = 40 amps  
Pump head = 20 psi  
Pump flow rate = 400 gpm

What will be the approximate values of pump head and motor current if pump speed is increased to 2,000 rpm?

- A. 22 psi, 44 amps
- B. 25 psi, 49 amps
- C. 22 psi, 49 amps
- D. 25 psi, 55 amps

ANSWER: D.

TOPIC: 191005  
KNOWLEDGE: K1.04 [2.7/2.8]  
QID: P428

A motor-driven centrifugal pump is operating at 600 rpm with the following parameters:

Motor current = 10 amps  
Pump head = 50 psi  
Pump flow rate = 200 gpm

What will be the approximate value of pump head if the flow is increased such that the motor draws 640 amps?

- A. 400 psi
- B. 600 psi
- C. 800 psi
- D. 1,200 psi

ANSWER: C.

TOPIC: 191005  
KNOWLEDGE: K1.04 [2.7/2.8]  
QID: P630

A motor-driven centrifugal pump is operating with a throttled discharge valve in an open system. If the pump discharge valve is fully opened to increase system flow rate, which one of the following will increase?

- A. Pump discharge pressure
- B. Available net positive suction head
- C. Motor amps
- D. Pump speed

ANSWER: C.

TOPIC: 191005  
KNOWLEDGE: K1.04 [2.7/2.8]  
QID: P1329

A centrifugal pump is operating with the following parameters:

Speed = 3,600 rpm  
Motor current = 100 amps  
Pump head = 50 psi  
Pump flow rate = 400 gpm

What will be the approximate values of pump head and motor current if pump speed is decreased to 2,000 rpm?

- A. 8.6 psi, 30.1 amps
- B. 8.6 psi, 17.1 amps
- C. 15.4 psi, 30.1 amps
- D. 15.4 psi, 17.1 amps

ANSWER: D.

TOPIC: 191005  
KNOWLEDGE: K1.04 [2.7/2.8]  
QID: P1429

A two-speed centrifugal pump is driven by an AC motor with the following initial conditions:

Pump speed = 400 rpm  
Motor current = 40 amps  
Pump head = 60 psid

What will be the approximate value of pump head if pump speed is increased to 1,600 rpm?

- A. 240 psid
- B. 480 psid
- C. 960 psid
- D. 3,840 psid

ANSWER: C.



TOPIC: 191005  
KNOWLEDGE: K1.04 [2.7/2.8]  
QID: P1530 (B2126)

A motor-driven centrifugal pump is operating with the following parameters:

Speed = 1,200 rpm  
Motor current = 40 amps  
Pump head = 20 psid  
Pump flow rate = 400 gpm

What will be the approximate values of pump head and motor current if pump speed is increased to 1,600 rpm?

- A. 25 psid, 55 amps
- B. 25 psid, 95 amps
- C. 36 psid, 55 amps
- D. 36 psid, 95 amps

ANSWER: D.

TOPIC: 191005  
KNOWLEDGE: K1.04 [2.7/2.8]  
QID: P1629

A motor-driven centrifugal pump is operating with the following parameters:

Speed = 1,200 rpm  
Motor current = 40 amps  
Pump head = 20 psi  
Pump flow rate = 400 gpm

What will be the approximate values of pump head and motor current if pump speed is increased to 1,800 rpm?

- A. 36 psi, 95 amps
- B. 36 psi, 135 amps
- C. 45 psi, 95 amps
- D. 45 psi, 135 amps

ANSWER: D.

TOPIC: 191005  
KNOWLEDGE: K1.04 [2.7/2.8]  
QID: P1729 (B1719)

A motor-driven centrifugal pump is operating with the following parameters:

Speed = 1,800 rpm  
Motor current = 40 amps  
Pump head = 20 psid  
Pump flow rate = 400 gpm

What will be the approximate values of pump head and motor current if pump speed is decreased to 1,200 rpm?

- A. 13 psid, 18 amps
- B. 13 psid, 12 amps
- C. 9 psid, 18 amps
- D. 9 psid, 12 amps

ANSWER: D.

TOPIC: 191005  
KNOWLEDGE: K1.04 [2.7/2.8]  
QID: P1828 (B2627)

A motor-driven centrifugal pump is operating with a flow rate of 3,000 gpm and a motor current of 150 amps. If the pump speed is reduced such that the flow rate is 2,000 gpm, what is the final motor current at the new lower speed?

- A. 44 amps
- B. 59 amps
- C. 67 amps
- D. 100 amps

ANSWER: A.

TOPIC: 191005  
KNOWLEDGE: K1.04 [2.7/2.8]  
QID: P2130 (B2229)

A motor-driven centrifugal pump is operating at 600 rpm with the following parameters:

Motor current = 100 amps  
Pump head = 50 psid  
Pump flow rate = 880 gpm

What will be the approximate value of pump head if pump speed is increased to 1,200 rpm?

- A. 71 psid
- B. 100 psid
- C. 141 psid
- D. 200 psid

ANSWER: D.

TOPIC: 191005  
KNOWLEDGE: K1.04 [2.7/2.8]  
QID: P2329 (B2321)

A multi-speed centrifugal pump is operating at 3,600 rpm with a flow rate of 3,000 gpm. Which one of the following approximates the new flow rate if the speed is decreased to 3,000 rpm?

- A. 1,000 gpm
- B. 1,500 gpm
- C. 2,000 gpm
- D. 2,500 gpm

ANSWER: D.

TOPIC: 191005  
KNOWLEDGE: K1.04 [2.7/2.8]  
QID: P2529 (B2527)

A multi-speed centrifugal pump is operating with a flow rate of 1,800 gpm at a speed of 3,600 rpm.

Which one of the following approximates the new flow rate if the pump speed is decreased to 2,400 rpm?

- A. 900 gpm
- B. 1,050 gpm
- C. 1,200 gpm
- D. 1,350 gpm

ANSWER: C.

TOPIC: 191005  
KNOWLEDGE: K1.04 [2.7/2.8]  
QID: P3129 (B1626)

A multi-speed motor-driven centrifugal pump is operating with the following parameters:

Motor current = 27 amps  
Pump head = 50 psid  
Pump flow rate = 880 gpm

Which one of the following will be the approximate new value of pump head if pump speed is increased such that the motor draws 64 amps?

- A. 89 psid
- B. 119 psid
- C. 211 psid
- D. 281 psid

ANSWER: A.

TOPIC: 191005  
KNOWLEDGE: K1.04 [2.7/2.8]  
QID: P3130 (B3127)

Which one of the following describes the relationship between the current drawn by an AC induction motor and the amount of heat generated in the motor windings?

- A. Heat generation is directly proportional to the current.
- B. Heat generation is proportional to the cube of the current.
- C. Heat generation is proportional to the square of the current.
- D. Heat generation is proportional to the square root of the current.

ANSWER: C.

TOPIC: 191005  
KNOWLEDGE: K1.04 [2.7/2.8]  
QID: P3430 (B1228)

A motor-driven centrifugal pump is operating at 600 rpm with the following parameters:

Motor current = 100 amps  
Pump head = 50 psid  
Pump flow rate = 880 gpm

What will be the approximate value of pump head if pump speed is increased such that the motor draws 640 amps?

- A. 93 psid
- B. 126 psid
- C. 173 psid
- D. 320 psid

ANSWER: C.

TOPIC: 191005  
KNOWLEDGE: K1.04 [2.7/2.8]  
QID: P3730 (B3722)

A rotary positive displacement pump (PDP) is being used to supply water to a piping system. The PDP is driven by an AC induction motor. The initial parameters are:

System pressure = 500 psig  
PDP flow rate = 50 gpm  
PDP motor current = 40 amps

After several hours, the PDP motor speed is increased such that the new PDP flow rate is 100 gpm. If system pressure does not change, what is the approximate value of the PDP motor current at the 100 gpm flow rate?

- A. 80 amps
- B. 160 amps
- C. 320 amps
- D. 640 amps

ANSWER: A.



TOPIC: 191005  
KNOWLEDGE: K1.04 [2.7/2.8]  
QID: P4515 (B4515)

Refer to the pump performance curves for a centrifugal cooling water pump (see figure below). The pump is being driven by a single-speed AC induction motor. Pump flow rate is being controlled by a throttled discharge flow control valve.

The following initial pump conditions exist:

Pump motor current = 50 amps  
Pump flow rate = 400 gpm

What will be the approximate value of pump motor current if the flow control valve is repositioned such that pump flow rate is 800 gpm?

- A. Less than 100 amps
- B. 200 amps
- C. 400 amps
- D. More than 500 amps

ANSWER: A.

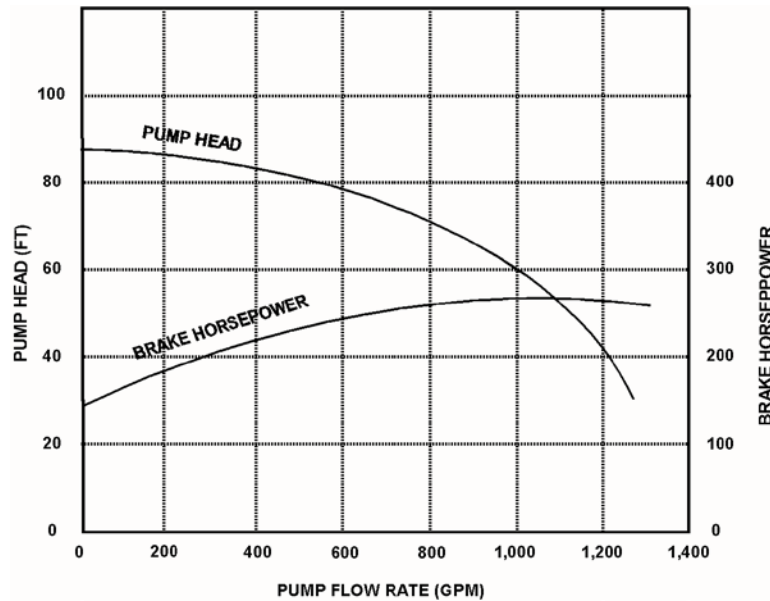

TOPIC: 191005  
KNOWLEDGE: K1.04 [2.7/2.8]  
QID: P4915 (B4914)

Consider two identical single-speed AC induction motors, one of which is connected to a radial-flow centrifugal pump and the other to a reciprocating-type positive displacement pump (PDP). Both pumps are taking suction at the same elevation from a vented water storage tank.

Each pump has a maximum design backpressure of 800 psig, and each is operating with the following initial conditions:

Flow rate = 200 gpm  
Backpressure = 400 psig  
Motor current = 100 amps

If the backpressure for each pump increases to 600 psig, the centrifugal pump will have a \_\_\_\_\_ flow rate than the PDP; and the centrifugal pump will have a \_\_\_\_\_ motor current than the PDP.

- A. lower; higher
- B. lower; lower
- C. higher; higher
- D. higher; lower

ANSWER: B.

TOPIC: 191005  
KNOWLEDGE: K1.04 [2.7/2.8]  
QID: P5814 (B5814)

Refer to the pump performance curves for a centrifugal cooling water pump (see figure below). The pump is being driven by a single-speed AC induction motor. Pump flow rate is being controlled by a throttled discharge flow control valve.

The following initial pump conditions exist:

Motor current = 100 amps  
Pump flow rate = 800 gpm

What will be the approximate value of pump motor current if the flow control valve is repositioned such that pump flow rate decreases to 400 gpm?

- A. Less than 15 amps
- B. 25 amps
- C. 50 amps
- D. Greater than 75 amps

ANSWER: D.

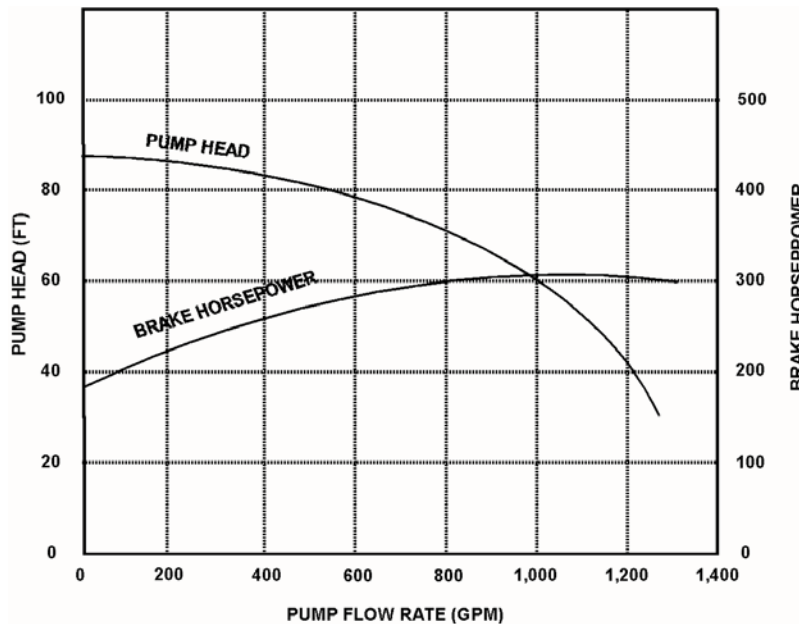

TOPIC: 191005  
KNOWLEDGE: K1.04 [2.7/2.8]  
QID: P6215 (B6215)

An AC induction motor is connected to a radial-flow centrifugal pump in a cooling water system. When the pump is started, the time period required to reach a stable running current will be shorter if the pump discharge valve is fully \_\_\_\_\_; and the stable running current will be lower if the pump discharge valve is fully \_\_\_\_\_.

- A. open; open
- B. open; closed
- C. closed; open
- D. closed; closed

ANSWER: D.

TOPIC: 191005  
KNOWLEDGE: K1.04 [2.7/2.8]  
QID: P6814 (B6814)

A centrifugal pump is driven by a single-speed AC induction motor. Pump flow rate is controlled by a throttled discharge flow control valve.

The following initial pump conditions exist:

Pump motor current = 50 amps  
Pump flow rate = 400 gpm

What will the resulting pump motor current be if the flow control valve is repositioned such that pump flow rate increases to 800 gpm?

- A. 100 amps
- B. 200 amps
- C. 400 amps
- D. Cannot be determined without additional information.

ANSWER: D.

TOPIC: 191005  
KNOWLEDGE: K1.04 [2.7/2.8]  
QID: P7214 (B7214)

An axial flow ventilation fan is being driven by an AC motor. The fan is operating at its maximum rated flow rate. How will the fan motor current initially change if the flow rate through the fan is decreased by partially closing a discharge damper?

- A. The motor current will increase in accordance with the centrifugal pump laws.
- B. The motor current will increase, but not in accordance with the centrifugal pump laws.
- C. The motor current will decrease in accordance with the centrifugal pump laws.
- D. The motor current will decrease, but not in accordance with the centrifugal pump laws.

ANSWER: B

TOPIC: 191005  
KNOWLEDGE: K1.04 [2.7/2.8]  
QID: P7414 (B7414)

Consider two identical single-speed AC induction motors, one of which is connected to a radial-flow centrifugal pump and the other to a rotary-type positive displacement pump (PDP). Both pumps are taking suction from the bottom of a vented water storage tank.

Each pump is operating with the following initial conditions:

Flow rate = 200 gpm  
Backpressure = 600 psig  
Motor current = 100 amps

If the backpressure for each pump decreases to 400 psig, the centrifugal pump will have a \_\_\_\_\_ flow rate than the PDP; and the centrifugal pump will have a \_\_\_\_\_ motor current than the PDP.

- A. lower; lower
- B. lower; higher
- C. higher; lower
- D. higher; higher

ANSWER: D.

TOPIC: 191005  
KNOWLEDGE: K1.04 [2.7/2.8]  
QID: P7605 (B7605)

Refer to the pump performance curves for a centrifugal cooling water pump (see figure below). The pump is being driven by a single-speed AC induction motor. Pump flow rate is being controlled by a throttled discharge flow control valve.

The following initial pump conditions exist:

Motor current = 10 amps  
Pump flow rate = 200 gpm

What will be the approximate value of pump motor current if the flow control valve is repositioned such that pump flow rate increases to 800 gpm?

- A. 15 amps
- B. 40 amps
- C. 160 amps
- D. Greater than 200 amps

ANSWER: A.

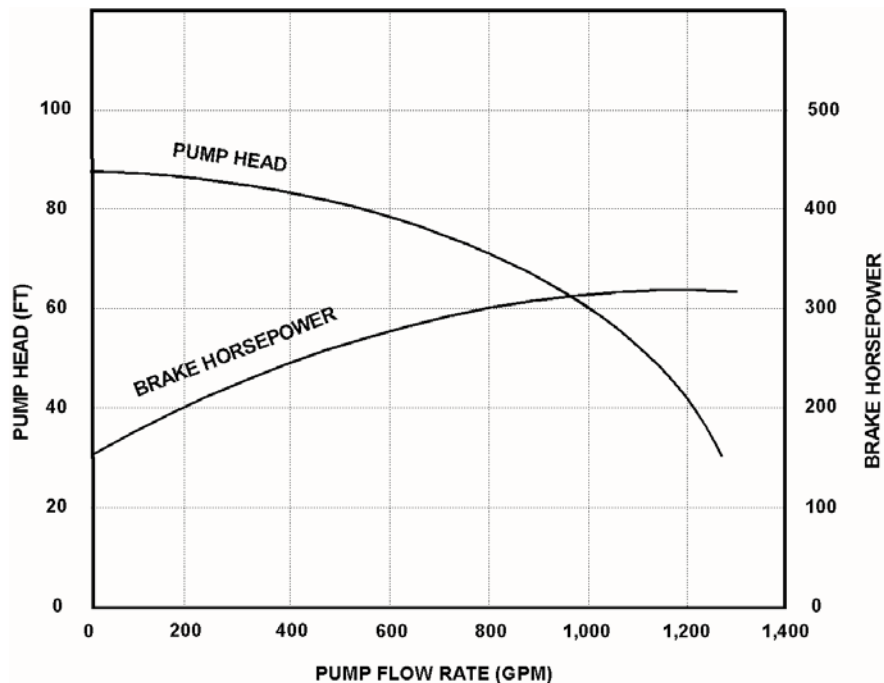

TOPIC: 191005  
KNOWLEDGE: K1.04 [2.7/2.8]  
QID: P7655 (B7655)

A motor-driven radial-flow centrifugal pump is operating to provide makeup water from a constant head source to a vented storage tank that is 30 feet tall. The pump is located at the base of the tank and discharges directly into the bottom of the tank. As the tank water level increases from 20 to 25 feet, the pump discharge pressure will \_\_\_\_\_; and the pump motor current will \_\_\_\_\_.

- A. decrease; decrease
- B. decrease; increase
- C. increase; decrease
- D. increase; increase

ANSWER: C.

TOPIC: 191005  
KNOWLEDGE: K1.04 [2.7/2.8]  
QID: P7665 (B7665)

An air-cooled AC induction motor is initially operating at steady-state conditions, producing a work output of 50 hp. A reduction in cooling air flow rate to the motor causes the average stator winding temperature to increase by 20°F. To maintain a 50 hp work output at the higher stator winding temperature, the voltage applied to the motor must be \_\_\_\_\_ because the stator winding resistance has \_\_\_\_\_.

- A. increased; increased
- B. increased; decreased
- C. decreased; increased
- D. decreased; decreased

ANSWER: A.

TOPIC: 191005  
KNOWLEDGE: K1.04 [2.7/2.8]  
QID: P7696 (B7696)

The rate of heat production in the stator windings of an AC induction motor is \_\_\_\_\_ proportional to the \_\_\_\_\_ of the stator current.

- A. directly, square
- B. directly; amount
- C. inversely; square
- D. inversely; amount

ANSWER: A.

TOPIC: 191005  
KNOWLEDGE: K1.04 [2.7/2.8]  
QID: P7706 (B7706)

An axial flow ventilation fan is being driven by an AC motor. The fan is operating at 90 percent of rated flow with its discharge damper partially closed. How will the fan motor current change if its discharge damper is fully opened?

- A. The motor current will increase in accordance with the centrifugal pump laws.
- B. The motor current will increase, but not in accordance with the centrifugal pump laws.
- C. The motor current will decrease in accordance with the centrifugal pump laws.
- D. The motor current will decrease, but not in accordance with the centrifugal pump laws.

ANSWER: D.



TOPIC: 191005  
KNOWLEDGE: K1.05 [2.8/2.7]  
QID: P29 (B2127)

The starting current in a typical AC induction motor is typically much higher than the full-load running current because...

- A. starting torque is lower than full-load running torque.
- B. starting torque is higher than full-load running torque.
- C. rotor speed during start is too low to generate significant counter electromotive force in the stator.
- D. rotor current during start is too low to generate significant counter electromotive force in the stator.

ANSWER: C.

TOPIC: 191005  
KNOWLEDGE: K1.05 [2.8/2.7]  
QID: P108 (B105)

The average starting current for a typical AC induction motor is approximately...

- A. ten to fifteen times its normal running current.
- B. five to seven times its normal running current.
- C. two to three times its normal running current.
- D. the same as its normal running current.

ANSWER: B.

TOPIC: 191005  
KNOWLEDGE: K1.05 [2.8/2.7]  
QID: P230

Which one of the following describes the motor current indications that would be observed during the start of a large AC motor connected to a load?

- A. Amps slowly increase to the normal operating value over a period of five time constants.
- B. Amps immediately increase to the normal operating value and stabilize.
- C. Amps immediately increase to many times the normal operating value and then decrease to the normal operating value.
- D. Amps immediately increase to the full-scale value and then decrease rapidly to zero due to overload protection.

ANSWER: C.

TOPIC: 191005  
KNOWLEDGE: K1.05 [2.8/2.7]  
QID: P429

If the discharge valve of a large motor-driven centrifugal pump is kept closed during a normal pump start, the current indication for the AC induction motor will rise to...

- A. approximately the full-load current value, and then decrease to the no-load current value.
- B. approximately the full-load current value, and then stabilize at the full-load current value.
- C. several times the full-load current value, and then decrease to the no-load current value.
- D. several times the full-load current value, and then decrease to the full-load value.

ANSWER: C.

TOPIC: 191005  
KNOWLEDGE: K1.05 [2.8/2.7]  
QID: P930 (B2928)

Which one of the following is a characteristic of a typical AC induction motor that causes starting current to be greater than running current?

- A. The rotor magnetic field induces an opposing voltage in the stator that is proportional to rotor speed.
- B. After the motor starts, resistors are added to the electrical circuit to limit the running current.
- C. A large amount of starting current is required to initially establish the rotating magnetic field.
- D. The rotor does not develop maximum induced current flow until it has achieved synchronous speed.

ANSWER: A.

TOPIC: 191005  
KNOWLEDGE: K1.05 [2.8/2.7]  
QID: P1230

The starting current in an AC motor is significantly higher than the full-load running current because...

- A. little counter electromotive force is induced in the rotor windings during motor start.
- B. motor torque production is highest during motor start.
- C. little counter electromotive force is induced in the stator windings during motor start.
- D. work performed by the motor is highest during motor start.

ANSWER: C.

TOPIC: 191005  
KNOWLEDGE: K1.05 [2.8/2.7]  
QID: P1330

Starting current in an AC induction motor is typically \_\_\_\_\_ times full-load running current.

- A. 1/4 to 1/2
- B. 2 to 3
- C. 5 to 7
- D. 10 to 12

ANSWER: C.

TOPIC: 191005  
KNOWLEDGE: K1.05 [2.8/2.7]  
QID: P1827 (B1327)

Which one of the following describes the motor current during the start of a typical motor-driven radial-flow centrifugal pump with a closed discharge valve?

- A. Current immediately increases to the full-load value and then gradually decreases to the no-load value.
- B. Current immediately increases to the full-load value and then stabilizes at the full-load value.
- C. Current immediately increases to many times the full-load value and then rapidly decreases to the no-load value after several seconds and then stabilizes.
- D. Current immediately increases to many times the full-load value and then rapidly decreases to the full-load value after several seconds and then stabilizes.

ANSWER: C.

TOPIC: 191005  
KNOWLEDGE: K1.05 [2.8/2.7]  
QID: P2229 (B28)

Which one of the following describes the motor current indications that would be observed during the start of a large motor-driven radial-flow centrifugal pump with a closed discharge valve?

- A. Current immediately increases to the full-load value and then gradually decreases to the no-load value over several minutes.
- B. Current immediately increases to the no-load value and then stabilizes.
- C. Current immediately increases to many times the no-load value and then rapidly decreases to the no-load value after several seconds.
- D. Current immediately increases to many times the no-load value and then gradually decreases to the no-load value after several minutes.

ANSWER: C.

TOPIC: 191005  
KNOWLEDGE: K1.05 [2.8/2.7]  
QID: P2230 (B2227)

Two identical AC induction motors are connected to identical radial-flow centrifugal pumps being used to provide cooling water flow in separate systems in a nuclear power plant. Each motor is rated at 1,000 hp. The discharge valve for pump A is fully open and the discharge valve for pump B is fully shut. Each pump is currently off.

If the pumps are started under these conditions, the longer time period required to stabilize motor current will be experienced by the motor for pump \_\_\_\_; and the higher stable motor current will be experienced by the motor for pump \_\_\_\_.

- A. A; A
- B. A; B
- C. B; A
- D. B; B

ANSWER: A.

TOPIC: 191005  
KNOWLEDGE: K1.05 [2.8/2.7]  
QID: P2430 (B2428)

Which one of the following describes when the highest stator current will be experienced by an AC induction motor?

- A. During motor operation at full load.
- B. During motor operation at zero load.
- C. Immediately after energizing the motor.
- D. Immediately after deenergizing the motor.

ANSWER: C.

TOPIC: 191005  
KNOWLEDGE: K1.05 [2.8/2.7]  
QID: P2730 (B2727)

Two identical AC induction motors are connected to identical radial-flow centrifugal pumps in identical but separate cooling water systems. Each motor is rated at 200 hp. The discharge valve for pump A is fully shut and the discharge valve for pump B is fully open. Each pump is currently off.

If the pumps are started under these conditions, the longer time period required to stabilize motor current will be experienced by the motor for pump \_\_\_\_; and the higher stable motor current will be experienced by the motor for pump \_\_\_\_.

- A. A; A
- B. A; B
- C. B; A
- D. B; B

ANSWER: D.

TOPIC: 191005  
KNOWLEDGE: K1.05 [2.8/2.7]  
QID: P2931 (B3529)

Two identical AC induction motors are connected to identical radial-flow centrifugal pumps in identical but separate cooling water systems. Each motor is rated at 200 hp. The discharge valve for pump A is fully shut and the discharge valve for pump B is fully open. Each pump is currently off.

If the pumps are started under these conditions, the shorter time period required to reach a stable running current will be experienced by the motor for pump \_\_\_\_; and the higher stable running current will be experienced by the motor for pump \_\_\_\_.

- A. A; A
- B. A; B
- C. B; A
- D. B; B

ANSWER: B.

TOPIC: 191005  
KNOWLEDGE: K1.05 [2.8/2.7]  
QID: P4615 (B4614)

To minimize the adverse effects of starting current, an AC induction motor should be started \_\_\_\_\_ to \_\_\_\_\_ the stator counter electromotive force.

- A. unloaded; quickly establish
- B. unloaded; delay
- C. partially loaded; quickly establish
- D. partially loaded; delay

ANSWER: A.

TOPIC: 191005  
KNOWLEDGE: K1.05 [2.8/2.7]  
QID: P5715 (B5714)

Two identical AC induction motors are connected to identical radial-flow centrifugal pumps in identical but separate cooling water systems. Each motor is rated at 200 hp. The discharge valve for pump A is fully open and the discharge valve for pump B is fully closed. Each pump is currently off.

If the pumps are started under these conditions, the shorter time period required to reach a stable running current will be experienced by the motor for pump \_\_\_\_; and the higher stable running current will be experienced by the motor for pump \_\_\_\_.

- A. A; A
- B. A; B
- C. B; A
- D. B; B

ANSWER: C.

TOPIC: 191005  
KNOWLEDGE: K1.06 [3.0/3.1]  
QID: P30 (B1826)

What is the primary reason for limiting the number of starts for an electric motor in a given period of time?

- A. Prevent overheating of the windings due to high starting currents.
- B. Prevent overheating of the windings due to shorting within the stator.
- C. Prevent rotor damage due to excessive cyclic stresses on the shaft.
- D. Prevent rotor damage due to excessive axial displacement of the shaft.

ANSWER: A.



TOPIC: 191005  
KNOWLEDGE: K1.06 [3.0/3.1]  
QID: P231 (B328)

The frequency of starts for large AC motors should be limited to prevent excessive...

- A. heat buildup within the motor.
- B. wear of pump thrust bearings.
- C. torsional stresses on the motor shaft.
- D. arcing and degradation of motor breaker contacts.

ANSWER: A.

TOPIC: 191005  
KNOWLEDGE: K1.06 [3.0/3.1]  
QID: P1031

The number of starts for an electric motor in a given period of time should be limited because overheating of the \_\_\_\_\_ can occur due to the \_\_\_\_\_ counter electromotive force produced at low rotor speeds.

- A. windings; low
- B. windings; high
- C. commutator and/or slip rings; low
- D. commutator and/or slip rings; high

ANSWER: A.

TOPIC: 191005  
KNOWLEDGE: K1.06 [3.0/3.1]  
QID: P1131 (B1128)

The frequency of start/stop cycles for an electrical motor is limited to prevent...

- A. overheating the motor windings.
- B. overheating the motor supply bus.
- C. excessive shaft torsional stresses.
- D. excessive cycling of the motor breaker.

ANSWER: A.

TOPIC: 191005  
KNOWLEDGE: K1.06 [3.0/3.1]  
QID: P2531 (B2528)

Frequent starts of large motors will result in overheating of the motor windings due to high current flow caused by...

- A. low electrical resistance of the motor windings.
- B. an electrical short circuit between the rotor and stator.
- C. high counter electromotive force at low rotor speeds.
- D. windage losses between the rotor and stator.

ANSWER: A.

TOPIC: 191005  
KNOWLEDGE: K1.06 [3.0/3.1]  
QID: P2631 (B228)

Which one of the following is the primary reason for limiting the number of motor starts in a given time period?

- A. Minimizes pitting of contacts in the motor breaker.
- B. Prevents excessive torsional stresses on motor shaft.
- C. Prevents overheating of motor windings.
- D. Minimizes axial stresses on motor bearings.

ANSWER: C.

TOPIC: 191005  
KNOWLEDGE: K1.06 [3.0/3.1]  
QID: P3331 (B3327)

A large centrifugal pump is driven by a 200 horsepower AC induction motor. The motor breaker control circuit contains the following protection devices: instantaneous overcurrent relay, motor thermal overload relay, control power fuses, and an anti-pumping device.

The pump had been manually started and stopped several times during a 5 minute period when the motor breaker tripped. Which one of the following is the most likely cause of the breaker trip?

- A. Motor thermal overload.
- B. Instantaneous overcurrent.
- C. Blown control power fuse.
- D. Anti-pumping device actuation.

ANSWER: A.