

TOPIC: 291005
KNOWLEDGE: K1.01 [2.6/2.6]
QID: B229

If a locked rotor occurs on an operating motor-driven pump, motor amps will...

- A. decrease due to the decreased pump flow rate.
- B. decrease due to the decreased rotor speed.
- C. increase due to the decreased pump flow rate.
- D. increase due to the decreased rotor speed.

ANSWER: D.

TOPIC: 291005
KNOWLEDGE: K1.01 [2.6/2.6]
QID: B1326 (P2127)

A cooling water pump is being driven by an AC induction motor. Which one of the following describes how and why pump motor current will change if the pump shaft seizes?

- A. Decreases due to decreased pump flow.
- B. Decreases due to increased counter electromotive force.
- C. Increases due to decreased pump flow.
- D. Increases due to decreased counter electromotive force.

ANSWER: D.

TOPIC: 291005
KNOWLEDGE: K1.01 [2.6/2.6]
QID: B2626 (P1427)

A motor-driven cooling water pump is operating normally. How will pump motor current respond if the pump experiences a locked rotor?

- A. Decreases immediately to zero due to breaker trip.
- B. Decreases immediately to no-load motor amps.
- C. Increases immediately to many times running current, then decreases to no-load motor amps.
- D. Increases immediately to many times running current, then decreases to zero upon breaker trip.

ANSWER: D.

TOPIC: 291005
KNOWLEDGE: K1.01 [2.6/2.6]
QID: B2826 (P3127)

A motor-driven centrifugal pump exhibits indications of pump failure while being started in an idle cooling water system. Assuming the pump motor breaker does not trip, which one of the following pairs of indications would be observed if the failure is a locked pump shaft?

- A. Lower than normal running current with zero system flow rate.
- B. Lower than normal running current with a fraction of normal system flow rate.
- C. Excessive duration of peak starting current with zero system flow rate.
- D. Excessive duration of peak starting current with a fraction of normal system flow rate.

ANSWER: C.

TOPIC: 291005
KNOWLEDGE: K1.01 [2.6/2.6]
QID: B5914 (P5914)

When a motor-driven centrifugal pump was started, the motor ammeter reading immediately increased to, and stabilized at, many times the normal operating value. Which one of the following describes a possible cause for the ammeter response?

- A. The pump was started with a fully closed discharge valve.
- B. The pump was started with a fully open discharge valve.
- C. The pump shaft seized upon start and did not rotate.
- D. The pump shaft separated from the motor shaft upon start.

ANSWER: C.

TOPIC: 291005
KNOWLEDGE: K1.02 [2.6/2.7]
QID: B1126 (P1528)

Continuous operation of a motor at rated load with a loss of required cooling to the motor windings will eventually result in...

- A. cavitation of the pumped fluid.
- B. failure of the motor overcurrent protection devices.
- C. breakdown of the motor insulation and electrical grounds.
- D. phase current imbalance in the motor and overspeed trip actuation.

ANSWER: C.

TOPIC: 291005
KNOWLEDGE: K1.02 [2.6/2.7]
QID: B1526 (P1028)

Which one of the following will result from prolonged operation of an AC induction motor with excessively high stator temperatures?

- A. Decreased electrical current demand due to reduced counter electromotive force.
- B. Increased electrical current demand due to reduced counter electromotive force.
- C. Decreased electrical resistance to ground due to breakdown of winding insulation.
- D. Increased electrical resistance to ground due to breakdown of winding insulation.

ANSWER: C.

TOPIC: 291005
KNOWLEDGE: K1.02 [2.6/2.7]
QID: B1927 (P528)

Which one of the following will provide the initial motor protection against electrical damage caused by gradual bearing failure?

- A. Thermal overload device
- B. Overcurrent trip relay
- C. Underfrequency relay
- D. Undervoltage device

ANSWER: A.

TOPIC: 291005
KNOWLEDGE: K1.03 [2.6/2.7]
QID: B2228 (P1128)

An AC generator is supplying an isolated electrical system with a power factor of 1.0. If generator voltage is held constant while real load (KW) increases, the current supplied by the generator will increase in direct proportion to the _____ of the change in real load. (Assume the generator power factor remains constant at 1.0.)

- A. cube
- B. square
- C. amount
- D. square root

ANSWER: C.

TOPIC: 291005
KNOWLEDGE: K1.03 [2.6/2.7]
QID: B2327

A main generator that is connected to an infinite power grid has the following generator indications:

100 MW
0 MVAR
2,900 amps
20 KV

If MVAR does not change while real load is increased to 200 MW, the current supplied by the generator will increase to approximately...

- A. 11,600 amps
- B. 8,200 amps
- C. 5,800 amps
- D. 4,100 amps

ANSWER: C.

TOPIC: 291005
KNOWLEDGE: K1.03 [2.6/2.7]
QID: B3227 (P3229)

Refer to the partial drawing of two identical radial-flow centrifugal pumps in a cooling water system (see figure below).

The cooling water system is being returned to service following maintenance on the pumps. Each pump is driven by an identical three-phase AC induction motor.

Pump A was started five minutes ago to initiate flow in the cooling water system. Pump B is about to be started.

When pump B is started, which one of the following would cause the ammeter for pump B to remain off-scale high for several seconds longer than usual before stabilizing at a normal running current indication?

- A. The pump packing was removed and not reinstalled.
- B. The pump was initially rotating in the reverse direction.
- C. Two phases of the motor windings were electrically switched.
- D. The coupling between the motor and the pump was removed and not reinstalled.

ANSWER: B.

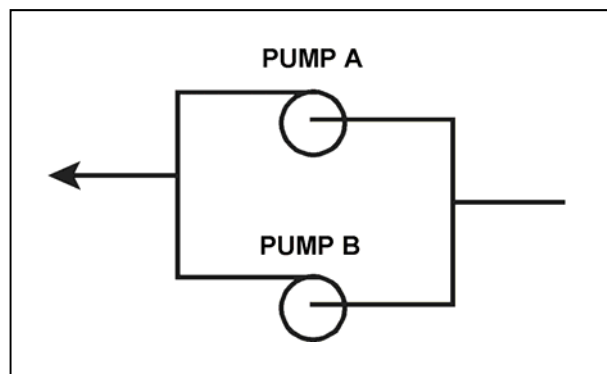

TOPIC: 291005
KNOWLEDGE: K1.03 [2.6/2.7]
QID: B4714 (P4714)

A nuclear power plant startup is in progress. The main generator has just been connected to the power grid with the following generator indications:

20 KV
288 amps
10 MW
0 MVAR

The operator suspects the main generator is operating under reverse power conditions and attempts to increase generator load (MW) normally. If the main generator is operating under reverse power conditions when the operator attempts to increase generator load, generator MW will initially _____; and generator amps will initially _____.

- A. decrease; decrease
- B. decrease; increase
- C. increase; decrease
- D. increase; increase

ANSWER: A.

TOPIC: 291005
KNOWLEDGE: K1.03 [2.6/2.7]
QID: B7615 (P7615)

A 4,000 KW diesel generator (DG) is supplying 2,000 KW to a 4.16 KV emergency bus. The DG governor is in the isochronous mode (no speed droop). The emergency bus is about to be synchronized with, and then connected to, an infinite offsite power grid by closing the emergency bus normal power feeder breaker.

The following stable emergency bus and normal power conditions currently exist:

<u>Emergency Bus (from DG)</u>	<u>Normal Power (from Offsite)</u>
4.16 KV	4.16 KV
60.0 Hz	60.1 Hz

When the emergency bus normal power feeder breaker is closed, the DG will... (Assume no additional operator action.)

- A. transfer KW load to the offsite power grid but remain partially loaded.
- B. transfer KW load to the offsite power grid until the DG is completely unloaded.
- C. acquire KW load from the offsite power grid but remain within its KW load rating.
- D. acquire KW load from the offsite power grid and ultimately exceed its KW load rating.

ANSWER: B.

TOPIC: 291005
KNOWLEDGE: K1.03 [2.6/2.7]
K1.04 [2.7/2.7]
QID: B7635 (P7635)

A radial-flow centrifugal cooling water pump is being powered by a 480 VAC induction motor. If the motor input voltage slowly decreases from 480 VAC to 450 VAC, the pump flow rate will _____; and the motor current will _____. (Assume the motor does not stall.)

- A. decrease; increase
- B. decrease; decrease
- C. remain the same; increase
- D. remain the same; decrease

ANSWER: A.

TOPIC: 291005
KNOWLEDGE: K1.03 [2.6/2.7]
QID: B7684 (P7684)

A main generator is connected to an infinite power grid with the following generator output parameters:

22 KV
60 Hertz
975 MW
200 MVAR (out)

Main generator stator winding temperature is abnormally high. Which one of the following contains a combination of manual adjustments to the main generator speed control and voltage regulator setpoints such that each adjustment will reduce the main generator stator winding temperature? (Assume power factor remains less than 1.0.)

	<u>Speed Setpoint</u>	<u>Voltage Setpoint</u>
A.	Increase	Increase
B.	Increase	Decrease
C.	Decrease	Increase
D.	Decrease	Decrease

ANSWER: D.

TOPIC: 291005
KNOWLEDGE: K1.03 [2.6/2.7]
QID: B7695 (P7695)

A 4,000 KW rated diesel generator (DG) is supplying 2,000 KW to a 4.16 KV emergency bus. The DG governor is in the isochronous mode (no speed droop). The emergency bus is about to be synchronized with, and then connected to, an infinite offsite power grid by closing the emergency bus normal power feeder breaker.

The following stable emergency bus and normal power conditions currently exist:

Emergency Bus (from DG)	Normal Power (from Offsite)
4.16 KV	4.16 KV
60.1 Hz	59.9 Hz

When the emergency bus normal power feeder breaker is closed, the DG will... (Assume no additional operator action is taken.)

- A. transfer KW load to the offsite power grid, but remain partially loaded.
- B. transfer KW load to the offsite power grid until the DG is completely unloaded.
- C. acquire KW load from the offsite power grid, but remain within its KW load rating.
- D. acquire KW load from the offsite power grid and ultimately exceed its KW load rating.

ANSWER: D.

TOPIC: 291005
KNOWLEDGE: K1.04 [2.7/2.7]
QID: B27

Given the following conditions for a variable-speed motor-driven centrifugal pump:

Flow rate = 2000 gpm
Motor current = 100 amps

If the flow rate is increased to 4000 gpm, which one of the following motor current values most closely approximates the actual value?

- A. 200 amps
- B. 400 amps
- C. 800 amps
- D. 1600 amps

ANSWER: C.

TOPIC: 291005
KNOWLEDGE: K1.04 [2.7/2.7]
QID: B227 (P228)

A motor-driven centrifugal pump is operating with a flow rate of 3,000 gpm and a current requirement of 200 amps. If the pump speed is reduced such that the flow rate is 2,000 gpm, what is the final current requirement at the new lower speed? (Assume a constant motor voltage.)

- A. 59 amps
- B. 89 amps
- C. 133 amps
- D. 150 amps

ANSWER: A.

TOPIC: 291005
KNOWLEDGE: K1.04 [2.7/2.7]
QID: B326 (P328)

A motor-driven centrifugal pump is operating with the following parameters:

Speed = 1,800 rpm
Motor current = 40 amps
Pump head = 20 psi
Pump flow rate = 400 gpm

What will be the approximate values of pump head and motor current if pump speed is increased to 2,000 rpm?

- A. 22 psi, 44 amps
- B. 25 psi, 49 amps
- C. 22 psi, 49 amps
- D. 25 psi, 55 amps

ANSWER: D.

TOPIC: 291005
KNOWLEDGE: K1.04 [2.7/2.7]
QID: B1228 (P3430)

A motor-driven centrifugal pump is operating at 600 rpm with the following parameters:

Motor current = 100 amps
Pump head = 50 psid
Pump flow rate = 880 gpm

What will be the approximate value of pump head if pump speed is increased such that the motor draws 640 amps?

- A. 93 psid
- B. 126 psid
- C. 173 psid
- D. 320 psid

ANSWER: C.

TOPIC: 291005
KNOWLEDGE: K1.04 [2.7/2.7]
QID: B1626 (P3129)

A multi-speed motor-driven centrifugal pump is operating with the following parameters:

Motor current = 27 amps
Pump head = 50 psid
Pump flow rate = 880 gpm

Which one of the following will be the approximate new value of pump head if pump speed is increased such that the motor draws 64 amps?

- A. 89 psid
- B. 119 psid
- C. 211 psid
- D. 281 psid

ANSWER: A.

TOPIC: 291005
KNOWLEDGE: K1.04 [2.7/2.7]
QID: B2030 (P428)

A motor-driven centrifugal pump is operating at 600 rpm with the following parameters:

Motor current = 10 amps
Pump head = 50 psid
Pump flow rate = 200 gpm

What will be the new value of pump head if the pump speed is increased such that the current requirements are now 640 amps?

- A. 400 psid
- B. 600 psid
- C. 800 psid
- D. 1,200 psid

ANSWER: C.

TOPIC: 291005
KNOWLEDGE: K1.04 [2.7/2.7]
QID: B2126 (P1530)

A motor-driven centrifugal pump is operating with the following parameters:

Speed = 1,200 rpm
Motor current = 40 amps
Pump head = 20 psid
Pump flow rate = 400 gpm

What will be the approximate values of pump head and motor current if pump speed is increased to 1,600 rpm?

- A. 25 psid, 55 amps
- B. 25 psid, 95 amps
- C. 36 psid, 55 amps
- D. 36 psid, 95 amps

ANSWER: D.

TOPIC: 291005
KNOWLEDGE: K1.04 [2.7/2.7]
QID: B2229 (P2130)

A motor-driven centrifugal pump is operating at 600 rpm with the following parameters:

Motor current = 100 amps
Pump head = 50 psid
Pump flow rate = 880 gpm

What will be the approximate value of pump head if pump speed is increased to 1,200 rpm?

- A. 71 psid
- B. 100 psid
- C. 141 psid
- D. 200 psid

ANSWER: D.

TOPIC: 291005
KNOWLEDGE: K1.04 [2.7/2.7]
QID: B2527 (P2529)

A multi-speed centrifugal pump is operating with a flow rate of 1,800 gpm at a speed of 3,600 rpm.

Which one of the following approximates the new flow rate if the pump speed is decreased to 2,400 rpm?

- A. 900 gpm
- B. 1,050 gpm
- C. 1,200 gpm
- D. 1,350 gpm

ANSWER: C.

TOPIC: 291005
KNOWLEDGE: K1.04 [2.7/2.7]
QID: B2627 (P1828)

A motor-driven centrifugal pump is operating with a flow rate of 3,000 gpm and a motor current of 150 amps. If the pump speed is reduced such that the flow rate is 2,000 gpm, what is the final motor current at the new lower speed?

- A. 44 amps
- B. 59 amps
- C. 67 amps
- D. 100 amps

ANSWER: A.

TOPIC: 291005
KNOWLEDGE: K1.04 [2.7/2.7]
QID: B3127 (P3130)

Which one of the following describes the relationship between the current drawn by an AC induction motor and the amount of heat generated in the motor windings?

- A. Heat generation is directly proportional to the current.
- B. Heat generation is proportional to the cube of the current.
- C. Heat generation is proportional to the square of the current.
- D. Heat generation is proportional to the square root of the current.

ANSWER: C.

TOPIC: 291005
KNOWLEDGE: K1.04 [2.7/2.7]
QID: B4515 (P4515)

Refer to the pump performance curves for a centrifugal cooling water pump (see figure below). The pump is being driven by a single-speed AC induction motor. Pump flow rate is being controlled by a throttled discharge flow control valve.

The following initial pump conditions exist:

Pump motor current = 50 amps
Pump flow rate = 400 gpm

What will be the approximate value of pump motor current if the flow control valve is repositioned such that pump flow rate is 800 gpm?

- A. Less than 100 amps
- B. 200 amps
- C. 400 amps
- D. More than 500 amps

ANSWER: A.

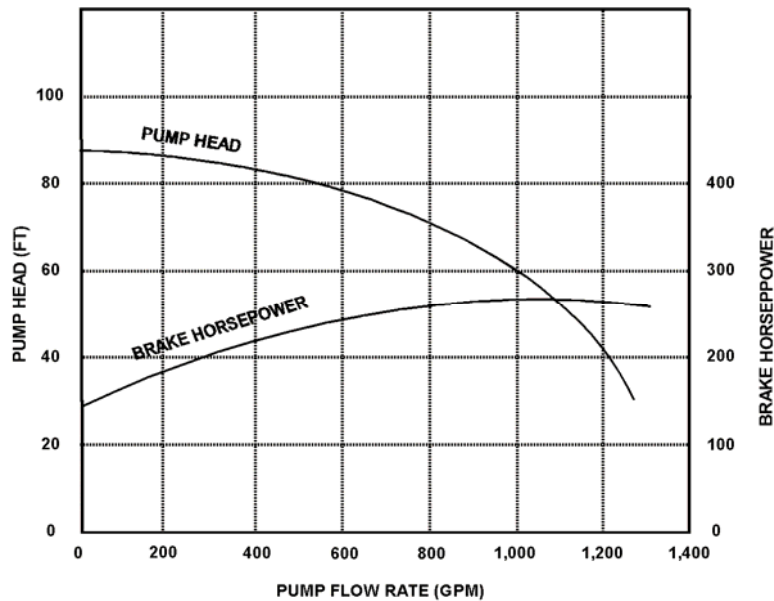

TOPIC: 291005
KNOWLEDGE: K1.04 [2.7/2.7]
QID: B4914 (P4915)

Consider two identical single-speed AC induction motors, one of which is connected to a radial-flow centrifugal pump and the other to a reciprocating-type positive displacement pump (PDP). Both pumps are taking suction at the same elevation from a vented water storage tank.

Each pump has a maximum design backpressure of 800 psig, and each is operating with the following initial conditions:

Flow rate = 200 gpm
Backpressure = 400 psig
Motor current = 100 amps

If the backpressure for each pump increases to 600 psig, the centrifugal pump will have a _____ flow rate than the PDP; and the centrifugal pump will have a _____ motor current than the PDP.

- A. lower; higher
- B. lower; lower
- C. higher; higher
- D. higher; lower

ANSWER: B.

TOPIC: 291005
KNOWLEDGE: K1.04 [2.7/2.7]
QID: B5814 (P5814)

Refer to the pump performance curves for a centrifugal cooling water pump (see figure below). The pump is being driven by a single-speed AC induction motor. Pump flow rate is being controlled by a throttled discharge flow control valve.

The following initial pump conditions exist:

Motor current = 100 amps
Pump flow rate = 800 gpm

What will be the approximate value of pump motor current if the flow control valve is repositioned such that pump flow rate decreases to 400 gpm?

- A. Less than 15 amps
- B. 25 amps
- C. 50 amps
- D. Greater than 75 amps

ANSWER: D.

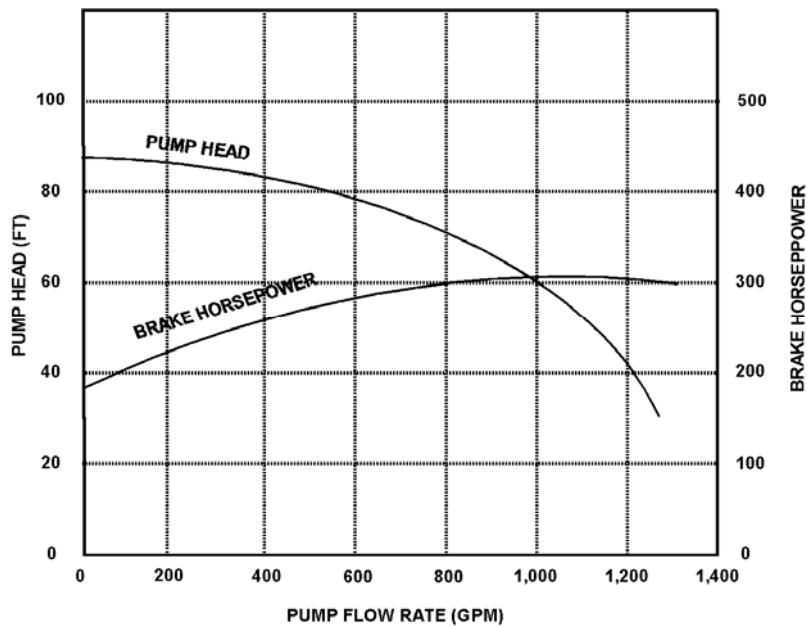

TOPIC: 291005
KNOWLEDGE: K1.04 [2.7/2.7]
QID: B6215 (P6215)

An AC induction motor is connected to a radial-flow centrifugal pump in a cooling water system. When the pump is started, the time period required to reach a stable running current will be shorter if the pump discharge valve is fully _____; and the stable running current will be lower if the pump discharge valve is fully _____.

- A. open; open
- B. open; closed
- C. closed; open
- D. closed; closed

ANSWER: D.

TOPIC: 291005
KNOWLEDGE: K1.04 [2.7/2.7]
QID: B6814 (P6814)

A centrifugal pump is driven by a single-speed AC induction motor. Pump flow rate is controlled by a throttled discharge flow control valve.

The following initial pump conditions exist:

Pump motor current = 50 amps
Pump flow rate = 400 gpm

What will the resulting pump motor current be if the flow control valve is repositioned such that pump flow rate increases to 800 gpm?

- A. 100 amps
- B. 200 amps
- C. 400 amps
- D. Cannot be determined without additional information.

ANSWER: D.

TOPIC: 291005
KNOWLEDGE: K1.04 [2.7/2.7]
QID: B7214 (P7214)

An axial flow ventilation fan is being driven by an AC motor. The fan is operating at its maximum rated flow rate. How will the fan motor current initially change if the flow rate through the fan is decreased by partially closing a discharge damper?

- A. The motor current will increase in accordance with the centrifugal pump laws.
- B. The motor current will increase, but not in accordance with the centrifugal pump laws.
- C. The motor current will decrease in accordance with the centrifugal pump laws.
- D. The motor current will decrease, but not in accordance with the centrifugal pump laws.

ANSWER: B

TOPIC: 291005
KNOWLEDGE: K1.04 [2.7/2.7]
QID: B7414 (P7414)

Consider two identical single-speed AC induction motors, one of which is connected to a radial-flow centrifugal pump and the other to a rotary-type positive displacement pump (PDP). Both pumps are taking suction from the bottom of a vented water storage tank.

Each pump is operating with the following initial conditions:

Flow rate = 200 gpm
Backpressure = 600 psig
Motor current = 100 amps

If the backpressure for each pump decreases to 400 psig, the centrifugal pump will have a _____ flow rate than the PDP; and the centrifugal pump will have a _____ motor current than the PDP.

- A. lower; lower
- B. lower; higher
- C. higher; lower
- D. higher; higher

ANSWER: D.

TOPIC: 291005
KNOWLEDGE: K1.04 [2.7/2.7]
QID: B7605 (P7605)

Refer to the pump performance curves for a centrifugal cooling water pump (see figure below). The pump is being driven by a single-speed AC induction motor. Pump flow rate is being controlled by a throttled discharge flow control valve.

The following initial pump conditions exist:

Motor current = 10 amps
Pump flow rate = 200 gpm

What will be the approximate value of pump motor current if the flow control valve is repositioned such that pump flow rate increases to 800 gpm?

- A. 15 amps
- B. 40 amps
- C. 160 amps
- D. Greater than 200 amps

ANSWER: A.

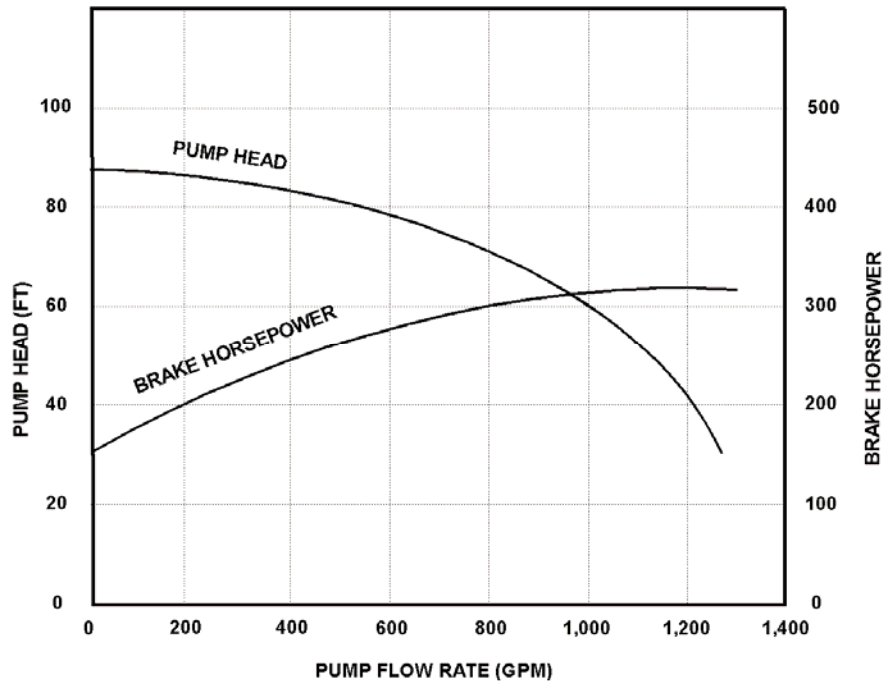

TOPIC: 291005
KNOWLEDGE: K1.04 [2.7/2.7]
QID: B7655 (P7655)

A motor-driven radial-flow centrifugal pump is operating to provide makeup water from a constant head source to a vented storage tank that is 30 feet tall. The pump is located at the base of the tank and discharges directly into the bottom of the tank. As the tank water level increases from 20 to 25 feet, the pump discharge pressure will _____; and the pump motor current will _____.

- A. decrease; decrease
- B. decrease; increase
- C. increase; decrease
- D. increase; increase

ANSWER: C.

TOPIC: 291005
KNOWLEDGE: K1.04 [2.7/2.7]
QID: B7665 (P7665)

An air-cooled AC induction motor is initially operating at steady-state conditions, producing a work output of 50 hp. A reduction in cooling air flow rate to the motor causes the average stator winding temperature to increase by 20°F. To maintain a 50 hp work output at the higher stator winding temperature, the voltage applied to the motor must be _____ because the stator winding resistance has _____.

- A. increased; increased
- B. increased; decreased
- C. decreased; increased
- D. decreased; decreased

ANSWER: A.

TOPIC: 291005
KNOWLEDGE: K1.04 [2.7/2.7]
QID: B7696 (P7696)

The rate of heat production in the stator windings of an AC induction motor is _____ proportional to the _____ of the stator current.

- A. directly, square
- B. directly; amount
- C. inversely; square
- D. inversely; amount

ANSWER: A.

TOPIC: 291005
KNOWLEDGE: K1.04 [2.7/2.7]
QID: B7706 (P7706)

An axial flow ventilation fan is being driven by an AC motor. The fan is operating at 90 percent of rated flow with its discharge damper partially closed. How will the fan motor current change if its discharge damper is fully opened?

- A. The motor current will increase in accordance with the centrifugal pump laws.
- B. The motor current will increase, but not in accordance with the centrifugal pump laws.
- C. The motor current will decrease in accordance with the centrifugal pump laws.
- D. The motor current will decrease, but not in accordance with the centrifugal pump laws.

ANSWER: D.

TOPIC: 291005
KNOWLEDGE: K1.05 [2.6/2.7]
QID: B28 (P2229)

Which one of the following describes the motor current indications that would be observed during the start of a large motor-driven radial-flow centrifugal pump with a closed discharge valve?

- A. Current immediately increases to the full-load value and then gradually decreases to the no-load value over several minutes.
- B. Current immediately increases to the no-load value and then stabilizes.
- C. Current immediately increases to many times the no-load value and then rapidly decreases to the no-load value after several seconds.
- D. Current immediately increases to many times the no-load value and then gradually decreases to the no-load value after several minutes.

ANSWER: C.

TOPIC: 291005
KNOWLEDGE: K1.05 [2.6/2.7]
QID: B105 (P108)

The average starting current for a typical AC induction motor is approximately...

- A. ten to fifteen times its normal running current.
- B. five to seven times its normal running current.
- C. two to three times its normal running current.
- D. the same as its normal running current.

ANSWER: B.

TOPIC: 291005
KNOWLEDGE: K1.05 [2.6/2.7]
QID: B1227

Which one of the following AC induction motor events is characterized by maximum rotor slip and a motor current five to six times full-load current?

- A. Starting of the motor
- B. Ground in motor windings
- C. Motor overloaded by 50 percent
- D. Motor operating at breakdown torque

ANSWER: A.

TOPIC: 291005
KNOWLEDGE: K1.05 [2.6/2.7]
QID: B1327 (P1827)

Which one of the following describes the motor current during the start of a typical motor-driven radial-flow centrifugal pump with a closed discharge valve?

- A. Current immediately increases to the full-load value and then gradually decreases to the no-load value.
- B. Current immediately increases to the full-load value and then stabilizes at the full-load value.
- C. Current immediately increases to many times the full-load value and then rapidly decreases to the no-load value after several seconds and then stabilizes.
- D. Current immediately increases to many times the full-load value and then rapidly decreases to the full-load value after several seconds and then stabilizes.

ANSWER: C.

TOPIC: 291005
KNOWLEDGE: K1.05 [2.6/2.7]
QID: B2127 (P29)

The starting current in a typical AC induction motor is typically much higher than the full-load running current because...

- A. starting torque is lower than full-load running torque.
- B. starting torque is higher than full-load running torque.
- C. rotor speed during start is too low to generate significant counter electromotive force in the stator.
- D. rotor current during start is too low to generate significant counter electromotive force in the stator.

ANSWER: C.

TOPIC: 291005
KNOWLEDGE: K1.05 [2.6/2.7]
QID: B2227 (P2230)

Two identical AC induction motors are connected to identical radial-flow centrifugal pumps being used to provide cooling water flow in separate systems in a nuclear power plant. Each motor is rated at 1,000 hp. The discharge valve for pump A is fully open and the discharge valve for pump B is fully shut. Each pump is currently off.

If the pumps are started under these conditions, the longer time period required to stabilize motor current will be experienced by the motor for pump ____; and the higher stable motor current will be experienced by the motor for pump ____.

- A. A; A
- B. A; B
- C. B; A
- D. B; B

ANSWER: A.

TOPIC: 291005
KNOWLEDGE: K1.05 [2.6/2.7]
QID: B2428 (P2430)

Which one of the following describes when the highest stator current will be experienced by an AC induction motor?

- A. During motor operation at full load.
- B. During motor operation at zero load.
- C. Immediately after energizing the motor.
- D. Immediately after deenergizing the motor.

ANSWER: C.

TOPIC: 291005
KNOWLEDGE: K1.05 [2.6/2.7]
QID: B2528 (P2531)

Frequent starts of large motors will result in overheating of the motor windings due to high current flow caused by...

- A. low electrical resistance of the motor windings.
- B. an electrical short circuit between the rotor and stator.
- C. high counter electromotive force at low rotor speeds.
- D. windage losses between the rotor and stator.

ANSWER: A.

TOPIC: 291005
KNOWLEDGE: K1.05 [2.6/2.7]
QID: B2727 (P2730)

Two identical AC induction motors are connected to identical radial-flow centrifugal pumps in identical but separate cooling water systems. Each motor is rated at 200 hp. The discharge valve for pump A is fully shut and the discharge valve for pump B is fully open. Each pump is currently off.

If the pumps are started under these conditions, the longer time period required to stabilize motor current will be experienced by the motor for pump ____; and the higher stable motor current will be experienced by the motor for pump ____.

- A. A; A
- B. A; B
- C. B; A
- D. B; B

ANSWER: D.

TOPIC: 291005
KNOWLEDGE: K1.05 [2.6/2.7]
QID: B2928 (P930)

Which one of the following is a characteristic of a typical AC induction motor that causes starting current to be greater than running current?

- A. The rotor magnetic field induces an opposing voltage in the stator that is proportional to rotor speed.
- B. After the motor starts, resistors are added to the electrical circuit to limit the running current.
- C. A large amount of starting current is required to initially establish the rotating magnetic field.
- D. The rotor does not develop maximum induced current flow until it has achieved synchronous speed.

ANSWER: A.

TOPIC: 291005
KNOWLEDGE: K1.05 [2.6/2.7]
QID: B3529 (P2931)

Two identical AC induction motors are connected to identical radial-flow centrifugal pumps in identical but separate cooling water systems. Each motor is rated at 200 hp. The discharge valve for pump A is fully shut and the discharge valve for pump B is fully open. Each pump is currently off.

If the pumps are started under these conditions, the shorter time period required to reach a stable running current will be experienced by the motor for pump ____; and the higher stable running current will be experienced by the motor for pump ____.

- A. A; A
- B. A; B
- C. B; A
- D. B; B

ANSWER: B.

TOPIC: 291005
KNOWLEDGE: K1.05 [2.6/2.7]
QID: B4614 (P4615)

To minimize the adverse effects of starting current, an AC induction motor should be started _____ to _____ the stator counter electromotive force.

- A. unloaded; quickly establish
- B. unloaded; delay
- C. partially loaded; quickly establish
- D. partially loaded; delay

ANSWER: A.

TOPIC: 291005
KNOWLEDGE: K1.05 [2.6/2.7]
QID: B5714 (P5715)

Two identical AC induction motors are connected to identical radial-flow centrifugal pumps in identical but separate cooling water systems. Each motor is rated at 200 hp. The discharge valve for pump A is fully open and the discharge valve for pump B is fully closed. Each pump is currently off.

If the pumps are started under these conditions, the shorter time period required to reach a stable running current will be experienced by the motor for pump ____; and the higher stable running current will be experienced by the motor for pump ____.

- A. A; A
- B. A; B
- C. B; A
- D. B; B

ANSWER: C.

TOPIC: 291005
KNOWLEDGE: K1.06 [2.9/3.1]
QID: B26

For large electric motors, why must the number of starts during a specified period of time be limited?

- A. To protect the power supply cables from insulation breakdown due to high starting current.
- B. To protect the motor windings from overheating.
- C. To prevent motor thrust bearing damage due to lack of lubrication.
- D. To prevent rotor seizure due to thermal expansion of the windings.

ANSWER: B.

TOPIC: 291005
KNOWLEDGE: K1.06 [2.9/3.1]
QID: B228 (P2631)

Which one of the following is the primary reason for limiting the number of motor starts in a given time period?

- A. Minimizes pitting of contacts in the motor breaker.
- B. Prevents excessive torsional stresses on motor shaft.
- C. Prevents overheating of motor windings.
- D. Minimizes axial stresses on motor bearings.

ANSWER: C.

TOPIC: 291005
KNOWLEDGE: K1.06 [2.9/3.1]
QID: B328 (P231)

The frequency of starts for large AC motors should be limited to prevent excessive...

- A. heat buildup within the motor.
- B. wear of pump thrust bearings.
- C. torsional stresses on the motor shaft.
- D. arcing and degradation of motor breaker contacts.

ANSWER: A.

TOPIC: 291005
KNOWLEDGE: K1.06 [2.9/3.1]
QID: B928

Motor winding temperature will be reduced by...

- A. increasing the reactive current flow in the stator windings.
- B. limiting the number of motor starts allowed in a given time period.
- C. decreasing the voltage supplied to the motor during full-load operation.
- D. decreasing the number of stator poles during the start sequence.

ANSWER: B.

TOPIC: 291005
KNOWLEDGE: K1.06 [2.9/3.1]
QID: B1128 (P1131)

The frequency of start/stop cycles for an electrical motor is limited to prevent...

- A. overheating the motor windings.
- B. excessive shaft torsional stresses.
- C. overheating the motor supply bus.
- D. excessive cycling of the motor breaker.

ANSWER: A.

TOPIC: 291005
KNOWLEDGE: K1.06 [2.9/3.1]
QID: B1826 (P30)

What is the primary reason for limiting the number of starts for an electric motor in a given period of time?

- A. Prevent overheating of the windings due to high starting currents.
- B. Prevent overheating of the windings due to shorting within the stator.
- C. Prevent rotor damage due to excessive cyclic stresses on the shaft.
- D. Prevent rotor damage due to excessive axial displacement of the shaft.

ANSWER: A.

TOPIC: 291005
KNOWLEDGE: K1.06 [2.9/3.1]
QID: B1928 (P1031)

The number of starts for an electric motor in a given period of time should be limited because overheating of the _____ can occur due to the _____ counter electromotive force produced at low rotor speeds.

- A. windings; high
- B. windings; low
- C. commutator and/or slip rings; high
- D. commutator and/or slip rings; low

ANSWER: B.

TOPIC: 291005
KNOWLEDGE: K1.06 [2.9/3.1]
QID: B3327 (P3331)

A large centrifugal pump is driven by a 200 horsepower AC induction motor. The motor breaker control circuit contains the following protection devices: instantaneous overcurrent relay, motor thermal overload relay, control power fuses, and an anti-pumping device.

The pump had been manually started and stopped several times during a 5 minute period when the motor breaker tripped. Which one of the following is the most likely cause of the breaker trip?

- A. Motor thermal overload.
- B. Instantaneous overcurrent.
- C. Blown control power fuse.
- D. Anti-pumping device actuation.

ANSWER: A.

TOPIC: 291005
KNOWLEDGE: K1.07 [2.6/2.6]
QID: B528

What unit of measurement is used to describe the rate of electron flow?

- A. Volt-amp reactive (VAR)
- B. Ohm
- C. Volt
- D. Ampere

ANSWER: D.

TOPIC: 291005
KNOWLEDGE: K1.07 [2.6/2.6]
QID: B628

A difference in electrical potential is measured in...

- A. amps.
- B. volts.
- C. ohms.
- D. volt-amps reactive.

ANSWER: B.

TOPIC: 291005
KNOWLEDGE: K1.07 [2.6/2.6]
QID: B828

The force that causes electrons to flow in an electrical circuit is called...

- A. power.
- B. current.
- C. voltage.
- D. resistance.

ANSWER: C.

TOPIC: 291005
KNOWLEDGE: K1.07 [2.6/2.6]
QID: B929

What is the significance of a 0.8 power factor when describing the output of a generator?

- A. 80 percent of the generator output is being converted to useful power.
- B. 80 percent of the generator output is being used by reactive loads.
- C. The generator is operating at 80 percent of its maximum rated output.
- D. The generator is 80 percent efficient at converting mechanical power to electrical power.

ANSWER: A.

TOPIC: 291005
KNOWLEDGE: K1.07 [2.6/2.6]
QID: B1129

The term "volt" describes...

- A. a rate of electron flow.
- B. the resistance to current flow.
- C. an electrical potential difference.
- D. the transfer of circulating currents.

ANSWER: C.

TOPIC: 291005
KNOWLEDGE: K1.07
QID: B3328

A 125 VDC battery is rated at 768 amp-hours for a continuous 50 KW load. Approximately how long will the fully charged battery be able to supply a continuous 50 KW load before the battery rating is exceeded?

- A. 115 minutes
- B. 90 minutes
- C. 75 minutes
- D. 60 minutes

ANSWER: A.

TOPIC: 291005
KNOWLEDGE: K1.07 [2.6/2.6]
QID: B5515

A 125 VDC battery is rated at 600 amp-hours for a continuous 50 KW load. Approximately how long will the fully charged battery be able to supply a continuous 50 KW load before the battery rating is exceeded?

- A. 115 minutes
- B. 90 minutes
- C. 75 minutes
- D. 60 minutes

ANSWER: B.

TOPIC: 291005
KNOWLEDGE: K1.08 [2.5/2.6]
QID: B29

Which one of the following describes the effects of field current changes on generator excitation and power factor with the generator connected to an infinite power grid?

- A. Increasing field current increases excitation and shifts power factor from lagging toward leading.
- B. Increasing field current increases excitation and shifts power factor from leading toward lagging.
- C. Decreasing field current increases excitation and shifts power factor from lagging toward leading.
- D. Decreasing field current increases excitation and shifts power factor from leading toward lagging.

ANSWER: B.

TOPIC: 291005
KNOWLEDGE: K1.08 [2.5/2.6]
QID: B120 (P115)

A main generator that is connected to an infinite power grid has the following initial indications:

100 MW
0 MVAR
2,900 amps
20 KV

If main generator field current is reduced slightly, amps will _____; and MW will _____.

- A. increase; decrease
- B. decrease; decrease
- C. increase; remain the same
- D. decrease; remain the same

ANSWER: C.

TOPIC: 291005
KNOWLEDGE: K1.08 [2.5/2.6]
QID: B226 (P1928)

A main generator is connected to an infinite power grid. Which one of the following conditions will exist if the generator is operating underexcited?

- A. Negative MVAR (VARs in) with a leading power factor
- B. Positive MVAR (VARs out) with a leading power factor
- C. Positive MVAR (VARs out) with a lagging power factor
- D. Negative MVAR (VARs in) with a lagging power factor

ANSWER: A.

TOPIC: 291005
KNOWLEDGE: K1.08 [2.5/2.6]
QID: B428

A main generator is connected to an infinite power grid with VARs out (positive VARs). Increasing main generator excitation will cause main generator current to _____ and main generator VARs to _____.

- A. increase; decrease
- B. increase; increase
- C. decrease; decrease
- D. decrease; increase

ANSWER: B.

TOPIC: 291005
KNOWLEDGE: K1.08 [2.5/2.6]
QID: B529

A main generator that is connected to an infinite power grid has the following indications:

100 MW
100 MVAR (out)
2,800 amps

If main generator field current is reduced slightly, amps will _____; and MW will _____.

- A. decrease; decrease
- B. increase; decrease
- C. decrease; remain the same
- D. increase; remain the same

ANSWER: C.

TOPIC: 291005
KNOWLEDGE: K1.08 [2.5/2.6]
QID: B729

A main generator that is connected to an infinite power grid has the following indications:

100 MW
100 MVAR (out)
2,800 amps

If main generator field current is increased slightly, amps will _____; and MW will _____.

- A. decrease; increase
- B. increase; increase
- C. decrease; remain the same
- D. increase; remain the same

ANSWER: D.

TOPIC: 291005
KNOWLEDGE: K1.08 [2.5/2.6]
QID: B1030

A main generator is operating in parallel with an infinite power grid with generator VARs currently at zero. If generator field current increases, generator VARs will become _____; and generator power factor will become _____.

- A. positive (VARs out); leading
- B. negative (VARs in); leading
- C. positive (VARs out); lagging
- D. negative (VARs in); lagging

ANSWER: C.

TOPIC: 291005
KNOWLEDGE: K1.08 [2.5/2.6]
QID: B1229

A main generator is operating in parallel with an infinite power grid with generator VARs currently at zero. If generator field current is increased, the generator will become _____ and will attain a _____ power factor.

- A. overexcited; leading
- B. underexcited; lagging
- C. underexcited; leading
- D. overexcited; lagging

ANSWER: D.

TOPIC: 291005
KNOWLEDGE: K1.08 [2.5/2.6]
QID: B1532 (P2628)

A main generator that is connected to an infinite power grid has the following indications:

100 MW
0 MVAR
2,900 amps
20 KV

If main generator excitation is increased, amps will _____; and MW will _____.

- A. remain the same; increase
- B. remain the same; remain the same
- C. increase; increase
- D. increase; remain the same

ANSWER: D.

TOPIC: 291005
KNOWLEDGE: K1.08 [2.5/2.6]
QID: B1729 (P1728)

A main generator that is connected to an infinite power grid has the following indications:

600 MW
100 MVAR (in)
13,800 amps
25 KV

If main generator excitation current is decreased slightly, amps will _____; and MVAR will _____.

- A. decrease; increase
- B. increase; increase
- C. decrease; decrease
- D. increase; decrease

ANSWER: B.

TOPIC: 291005
KNOWLEDGE: K1.08 [2.5/2.6]
QID: B1830 (P1428)

A main generator that is connected to an infinite power grid has the following indications:

600 MW
100 MVAR (in)
13,800 amps
25 KV

If main generator excitation current is increased slightly, amps will initially _____; and MW will initially _____.

- A. decrease; increase
- B. increase; increase
- C. decrease; remain the same
- D. increase; remain the same

ANSWER: C.

TOPIC: 291005
KNOWLEDGE: K1.08 [2.5/2.6]
QID: B2028 (P2027)

A diesel generator (DG) is supplying both KW and KVAR to an electrical bus that is connected to an infinite power grid. Assuming DG and bus voltage do not change, if the DG voltage regulator setpoint is increased slightly, DG KW will _____; and DG amps will _____.

- A. remain the same; increase
- B. remain the same; remain the same
- C. increase; increase
- D. increase; remain the same

ANSWER: A.

TOPIC: 291005
KNOWLEDGE: K1.08 [2.5/2.6]
QID: B2128 (P928)

A main generator is operating in parallel with an infinite power grid. If the generator field current is slowly and continuously decreased, the generator will experience high current due to: (Assume no generator protective actuations occur.)

- A. excessive generator MW.
- B. excessive generator MVAR out.
- C. excessive generator MVAR in.
- D. generator reverse power.

ANSWER: C.

TOPIC: 291005
KNOWLEDGE: K1.08 [2.5/2.6]
QID: B2330 (P2328)

A main generator that is connected to an infinite power grid has the following indications:

600 MW
100 MVAR (out)
13,800 amps
25 KV

If main generator field current is decreased, amps will initially _____; and MVAR will initially _____.

- A. decrease; increase
- B. increase; increase
- C. decrease; decrease
- D. increase; decrease

ANSWER: C.

TOPIC: 291005
KNOWLEDGE: K1.08 [2.5/2.6]
QID: B2444 (P2439)

Two identical 1,000 MW generators are operating in parallel, supplying all the loads on an isolated electrical bus. The generator output breakers provide identical protection for the generators. Generator A and B output indications are as follows:

<u>Generator A</u>	<u>Generator B</u>
28 KV	28 KV
60 Hertz	60 Hertz
150 MW	100 MW
25 MVAR (out)	50 MVAR (out)

A malfunction causes the voltage regulator setpoint for generator B to slowly and continuously decrease. If no operator action is taken, the electrical current indication for generator B will...

- A. initially decrease, and then increase until the output breaker for generator A trips on overcurrent.
- B. initially decrease, and then increase until the output breaker for generator B trips on overcurrent.
- C. decrease continuously until the output breaker for generator A trips on overcurrent.
- D. decrease continuously until the output breaker for generator B trips on reverse power.

ANSWER: A.

TOPIC: 291005
KNOWLEDGE: K1.08 [2.5/2.6]
QID: B2530 (P2528)

A diesel generator (DG) is supplying both KW and KVAR to an electrical bus that is connected to an infinite power grid. Assuming bus voltage does not change, if the DG voltage regulator setpoint is decreased slightly, DG KW will _____; and DG amps will _____.

- A. remain the same; decrease
- B. remain the same; remain the same
- C. decrease; decrease
- D. decrease; remain the same

ANSWER: A.

TOPIC: 291005
KNOWLEDGE: K1.08 [2.5/2.6]
QID: B2543 (P2540)

Two identical 1,000 MW generators are operating in parallel supplying the same isolated electrical bus. The generator output breakers also provide identical protection for the generators. Generator A and B output indications are as follows:

<u>Generator A</u>	<u>Generator B</u>
22 KV	22 KV
60.2 Hertz	60.2 Hertz
200 MW	200 MW
25 MVAR (out)	50 MVAR (out)

A malfunction causes the voltage regulator setpoint for generator A to slowly and continuously increase. If no operator action is taken, generator B output current will...

- A. initially decrease, and then increase until the output breaker for generator A trips on overcurrent.
- B. initially decrease, and then increase until the output breaker for generator B trips on overcurrent.
- C. increase continuously until the output breaker for generator A trips on overcurrent.
- D. increase continuously until the output breaker for generator B trips on overcurrent.

ANSWER: A.

TOPIC: 291005
KNOWLEDGE: K1.08 [2.5/2.6]
QID: B2729 (P2728)

A main generator is supplying power to an infinite power grid. If the generator field current is slowly and continuously increased, the generator will experience high current due to: (Assume no generator protective actuations occur.)

- A. generator reverse power.
- B. excessive generator MW.
- C. excessive generator MVAR in.
- D. excessive generator MVAR out.

ANSWER: D

TOPIC: 291005
KNOWLEDGE: K1.08 [2.5/2.6]
QID: B3344 (P2041)

Two identical 1,000 MW generators are operating in parallel, supplying the same isolated electrical bus. The generator output breakers provide identical protection for the generators. Generator A and B output indications are as follows:

<u>Generator A</u>	<u>Generator B</u>
22.5 KV	22.5 KV
60.2 Hertz	60.2 Hertz
750 MW	750 MW
25 MVAR (out)	50 MVAR (out)

A malfunction causes the voltage regulator setpoint for generator B to slowly and continuously increase. If no operator action is taken, which one of the following describes the electrical current indications for generator A?

- A. Current will decrease continuously until the output breaker for generator A trips on reverse power.
- B. Current will decrease continuously until the output breaker for generator B trips on reverse power.
- C. Current will initially decrease, and then increase until the output breaker for generator A trips on overcurrent.
- D. Current will initially decrease, and then increase until the output breaker for generator B trips on overcurrent.

ANSWER: D.

TOPIC: 291005
KNOWLEDGE: K1.08 [2.5/2.6]
QID: B3543 (P2838)

Two identical 1,000 MW generators are operating in parallel supplying the same isolated electrical bus. The generator output breakers provide identical protection for the generators. Generator A and B output indications are as follows:

<u>Generator A</u>	<u>Generator B</u>
22 KV	22 KV
60.2 Hertz	60.2 Hertz
800 MW	800 MW
50 MVAR (out)	25 MVAR (in)

A malfunction causes the voltage regulator for generator B to slowly and continuously increase the terminal voltage for generator B. If no operator action is taken, generator B output current will...

- A. increase continuously until the output breaker for generator A trips on overcurrent.
- B. increase continuously until the output breaker for generator B trips on overcurrent.
- C. initially decrease, and then increase until the output breaker for generator A trips on overcurrent.
- D. initially decrease, and then increase until the output breaker for generator B trips on overcurrent.

ANSWER: D.

TOPIC: 291005
KNOWLEDGE: K1.08 [2.5/2.6]
QID: B3629 (P3629)

A main turbine-generator is operating in parallel with an infinite power grid. If the turbine control valves (or throttle valves) slowly fail open, the generator will experience high current primarily due to... (Assume no generator protective actuations occur.)

- A. excessive generator MW.
- B. excessive generator VARs out.
- C. excessive generator VARs in.
- D. generator reverse power.

ANSWER: A.

TOPIC: 291005
KNOWLEDGE: K1.08 [2.5/2.6]
K1.09 [2.3/2.6]
QID: B4115 (P4115)

A main generator is operating and connected to an infinite power grid. Elevated main generator winding temperature requires a reduction in reactive load from 200 MVAR (out) to 150 MVAR (out). To accomplish the reactive load reduction, the operator must _____ the generator field current; when generator reactive load equals 150 MVAR (out) the generator power factor will be _____ than the initial power factor.

- A. increase; larger
- B. increase; smaller
- C. decrease; larger
- D. decrease; smaller

ANSWER: C.

TOPIC: 291005
KNOWLEDGE: K1.08 [2.5/2.6]
K1.09 [2.3/2.6]
QID: B4315 (P6515)

A main generator is connected to an infinite power grid with the following generator output parameters:

22 KV
60 Hertz
575 MW
100 MVAR (out)

Which one of the following contains a combination of manual adjustments to the main generator voltage regulator and speed control setpoints such that each adjustment will result in main generator operation at a power factor closer to 1.0? (Assume the generator power factor remains less than 1.0.)

- | | <u>Voltage
Setpoint</u> | <u>Speed
Setpoint</u> |
|----|-----------------------------|---------------------------|
| A. | Increase | Increase |
| B. | Increase | Decrease |
| C. | Decrease | Increase |
| D. | Decrease | Decrease |

ANSWER: C.

TOPIC: 291005
KNOWLEDGE: K1.08 [2.5/2.6]
QID: B4615 (P4620)

Two identical 1,000 MW generators are operating in parallel supplying the same isolated electrical bus. The generator output breakers provide identical protection for the generators. Generator A and B output indications are as follows:

<u>Generator A</u>	<u>Generator B</u>
22 KV	22 KV
60.2 Hertz	60.2 Hertz
200 MW	200 MW
25 MVAR (out)	50 MVAR (out)

A malfunction causes the voltage regulator setpoint for generator B to slowly and continuously increase. If no operator action is taken, generator A output current will...

- A. increase continuously until the output breaker for generator A trips on overcurrent.
- B. decrease continuously until the output breaker for generator B trips on overcurrent.
- C. initially decrease, and then increase until the output breaker for generator A trips on overcurrent.
- D. initially decrease, and then increase until the output breaker for generator B trips on overcurrent.

ANSWER: D.

TOPIC: 291005
KNOWLEDGE: K1.08 [2.5/2.6]
K1.09 [2.3/2.6]
QID: B5015

A main generator is connected to an infinite power grid with the following generator output parameters:

22 KV
60 Hertz
600 MW
100 MVAR (in)

Which one of the following contains a combination of manual adjustments to the main generator voltage regulator and speed control setpoints such that each adjustment will result in main generator operation at a power factor closer to 1.0? (Assume the generator power factor remains less than 1.0.)

- | | <u>Voltage
Setpoint</u> | <u>Speed
Setpoint</u> |
|----|-----------------------------|---------------------------|
| A. | Increase | Increase |
| B. | Increase | Decrease |
| C. | Decrease | Increase |
| D. | Decrease | Decrease |

ANSWER: A.

TOPIC: 291005
KNOWLEDGE: K1.08 [2.5/2.6]
QID: B5415 (P5414)

A main generator is connected to an infinite power grid. Which one of the following pairs of main generator output parameters places the generator in the closest proximity to slipping a pole.

- A. 800 MW; 200 MVAR (in)
- B. 800 MW; 600 MVAR (in)
- C. 400 MW; 200 MVAR (out)
- D. 400 MW; 600 MVAR (out)

ANSWER: B.

TOPIC: 291005
KNOWLEDGE: K1.08 [2.5/2.6]
QID: B6014 (P6014)

During a surveillance test, a 4,000 KW diesel generator (DG) and a 1,000 MW main generator (MG) at a nuclear power plant are connected to the same power grid.

The following stable generator output conditions exist:

<u>Diesel Generator</u>	<u>Main Generator</u>
700 KW	800 MW
200 KVAR (out)	100 MVAR (out)

A malfunction then occurs, causing the voltage regulator for the MG to slowly and continuously increase the MG field current. If no operator action is taken, the DG output current will _____ until a breaker trip separates the generators.

- A. remain about the same
- B. increase continuously
- C. initially increase, and then decrease
- D. initially decrease, and then increase

ANSWER: D.

TOPIC: 291005
KNOWLEDGE: K1.08 [2.5/2.6]
K1.09 [2.3/2.6]
QID: B6115 (P6114)

A main generator is connected to an infinite power grid with the following generator output parameters:

22 KV
60 Hertz
575 MW
100 MVAR (in)

Which one of the following contains a combination of minor adjustments to the main generator voltage regulator and speed control setpoints such that each adjustment will cause the main generator to operate at a power factor closer to 1.0? (Assume the generator power factor remains less than 1.0.)

	<u>Voltage Setpoint</u>	<u>Speed Setpoint</u>
A.	Increase	Increase
B.	Increase	Decrease
C.	Decrease	Increase
D.	Decrease	Decrease

ANSWER: A.

TOPIC: 291005
KNOWLEDGE: K1.08 [2.5/2.6]
QID: B6314 (P6315)

A main turbine-generator is connected to an infinite power grid with the following generator output parameters:

25 KV
20,000 amps
830 MW
248 MVAR (out)

Which one of the following will significantly increase main generator output current without a significant change in main generator real load? (Assume the generator power factor remains less than 1.0.)

- A. Increasing the main turbine speed control setpoint.
- B. Increasing the main generator voltage regulator setpoint.
- C. A 10 percent decrease in power grid electrical loads.
- D. A 10 percent increase in power grid electrical loads.

ANSWER: B

TOPIC: 291005
KNOWLEDGE: K1.08 [2.5/2.6]
QID: B6615 (P6614)

During a surveillance test, a 4,000 KW diesel generator (DG) and a 1,000 MW main generator (MG) at a nuclear power plant are connected to a power grid.

The following stable generator output conditions initially exist:

<u>Diesel Generator</u>	<u>Main Generator</u>
700 KW	800 MW
200 KVAR (out)	100 MVAR (out)

A malfunction then occurs, causing the voltage regulator for the MG to slowly and continuously decrease the MG field current. If no operator action is taken, the DG output current will _____ until a breaker trip separates the generators.

- A. increase continuously
- B. decrease continuously
- C. initially increase, and then decrease
- D. initially decrease, and then increase

ANSWER: A.

TOPIC: 291005
KNOWLEDGE: K1.08 [2.5/2.6]
QID: B6915 (P6914)

A main generator is connected to an infinite power grid with the following generator output parameters:

100 MW
0 MVAR
2,625 amps
22 KV

If the main generator field current is decreased, main generator amps will initially _____; and MW will initially _____.

- A. decrease; decrease
- B. increase; decrease
- C. decrease; remain the same
- D. increase; remain the same

ANSWER: D.

TOPIC: 291005
KNOWLEDGE: K1.08 [2.5/2.6]
K1.09 [2.3/2.6]
QID: B7644 (P7644)

A main generator is connected to an infinite power grid with the following generator output parameters:

22 KV
60 Hertz
575 MW
100 MVAR (out)

Which one of the following contains a combination of minor adjustments to the main generator voltage regulator and speed control setpoints such that each adjustment will cause the main generator to operate at a power factor farther from 1.0? (Assume the generator power factor remains less than 1.0.)

	<u>Voltage Setpoint</u>	<u>Speed Setpoint</u>
A.	Increase	Increase
B.	Increase	Decrease
C.	Decrease	Increase
D.	Decrease	Decrease

ANSWER: B.

TOPIC: 291005
KNOWLEDGE: K1.09 [2.3/2.6]
QID: B329

A main generator is operating with the following output parameters:

24 KV
20,700 amps
800 MW
325 MVAR (in)

What is the power factor of the main generator?

- A. 0.93 leading
- B. 0.93 lagging
- C. 0.81 leading
- D. 0.81 lagging

ANSWER: A.

TOPIC: 291005
KNOWLEDGE: K1.09 [2.3/2.6]
QID: B630

A 4.16 KV diesel generator (DG) is loaded to 2,850 KW with a 0.85 power factor. What is the approximate KVAR load on the DG?

- A. 503 KVAR
- B. 1,766 KVAR
- C. 2,850 KVAR
- D. 3,353 KVAR

ANSWER: B.

TOPIC: 291005
KNOWLEDGE: K1.09 [2.3/2.6]
QID: B930

A 125 VDC motor is rated at 10 KW. What is the current rating for the motor?

- A. 4.6 amps
- B. 8.0 amps
- C. 46.2 amps
- D. 80.0 amps

ANSWER: D.

TOPIC: 291005
KNOWLEDGE: K1.09 [2.3/2.6]
QID: B1529 (P2228)

A diesel generator (DG) is supplying an electrical bus that is connected to an infinite power grid. Assuming DG terminal voltage and bus frequency do not change, if the DG governor setpoint is increased from 60 Hz to 60.1 Hz, DG KVAR will be _____; and DG amps will be _____.

- A. the same; higher
- B. the same; the same
- C. higher; higher
- D. higher; the same

ANSWER: A.

TOPIC: 291005
KNOWLEDGE: K1.09 [2.3/2.6]
QID: B2029 (P1128)

If the voltage supplied by an AC generator to an isolated electrical bus is held constant while loads (KW only) are added to the bus, the current supplied by the generator will increase in direct proportion to the _____ of the change in KW. (Assume power factor does not change.)

- A. cube root
- B. square root
- C. amount
- D. square

ANSWER: C.

TOPIC: 291005
KNOWLEDGE: K1.09 [2.3/2.6]
QID: B2929

Refer to the drawing of an electrical system power triangle (see figure below).

Which one of the following represents the power factor for this system?

- A. A divided by B
- B. A divided by C
- C. B divided by A
- D. B divided by C

ANSWER: D.

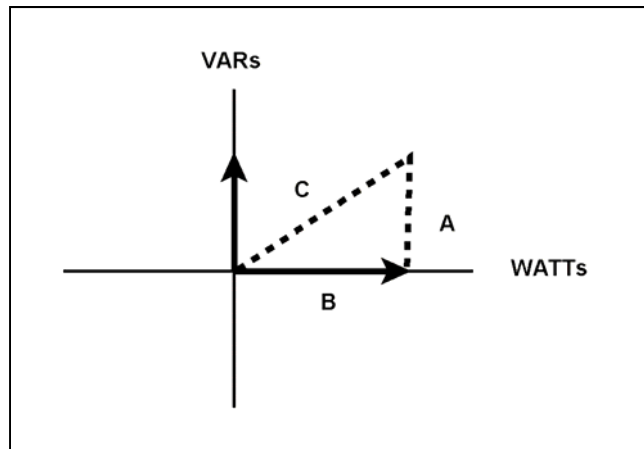

TOPIC: 291005
KNOWLEDGE: K1.09 [2.3/2.6]
QID: B3130 (P3142)

A nuclear power plant was initially operating at 80 percent power in the middle of a fuel cycle with the main generator connected to an infinite power grid with the following main generator output parameters:

60 Hz
25 KV
300 MVAR (out)
800 MW

A hydraulic oil system malfunction occurred that caused the main turbine steam inlet valves to slowly drift closed. After 10 minutes, the main generator real load decreased to 600 MW. Assuming no operator actions were taken, how were the remaining main generator output parameters affected after the above 10 minute period?

	<u>Frequency (Hz)</u>	<u>Voltage (KV)</u>	<u>Reactive Load (MVAR)</u>
A.	Decreased	Decreased	No change
B.	Decreased	No change	Decreased
C.	No change	No change	No change
D.	No change	Decreased	Decreased

ANSWER: C.

TOPIC: 291005
KNOWLEDGE: K1.09 [2.3/2.6]
QID: B4015

Refer to the drawing of an electrical system power curve (see figure below).

If the system is operating at point A, which one of the following is the power factor for this system?

- A. 0.80
- B. 0.88
- C. 0.93
- D. 0.97

ANSWER: D.

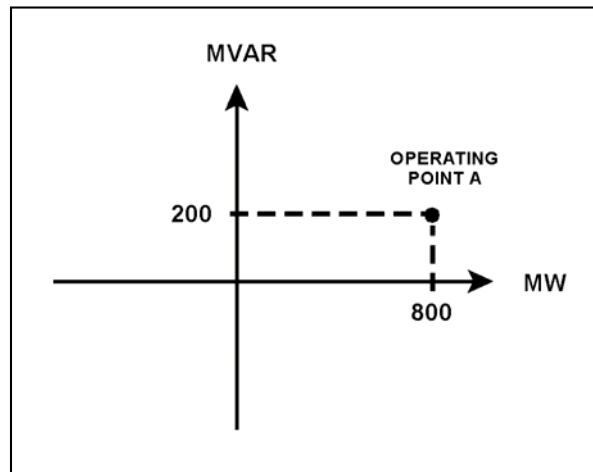

TOPIC: 291005
KNOWLEDGE: K1.09 [2.3/2.6]
QID: B4415

A main generator is supplying 300 MVAR to the power grid with a 0.85 power factor. What is the approximate MW load on the main generator?

- A. 186 MW
- B. 353 MW
- C. 484 MW
- D. 569 MW

ANSWER: C.

TOPIC: 291005
KNOWLEDGE: K1.09 [2.3/2.6]
QID: B4815 (P4814)

A main generator is connected to an infinite power grid with the following generator output parameters:

22 KV
60 Hertz
575 MW
100 MVAR (in)

Which one of the following contains a combination of manual adjustments to the main generator voltage regulator and speed control setpoints such that each adjustment will initially result in a decrease in main generator amps?

- | | <u>Voltage Setpoint</u> | <u>Speed Setpoint</u> |
|----|-------------------------|-----------------------|
| A. | Increase | Increase |
| B. | Increase | Decrease |
| C. | Decrease | Increase |
| D. | Decrease | Decrease |

ANSWER: B.

TOPIC: 291005
KNOWLEDGE: K1.09 [2.3/2.6]
QID: B6415

A main generator has the following output parameters:

830 MW
25 KV
20,000 amps

What is the reactive power for this generator?

- A. 36 MVAR
- B. 143 MVAR
- C. 247 MVAR
- D. 330 MVAR

ANSWER: C.

TOPIC: 291005
KNOWLEDGE: K1.09 [2.3/2.6]
QID: B6515

A main generator is supplying 300 MVAR with a 0.90 power factor. What is the approximate MW load on the main generator?

- A. 145 MW
- B. 270 MW
- C. 484 MW
- D. 619 MW

ANSWER: D.