

TOPIC: 291001  
KNOWLEDGE: K1.01 [3.4/3.5]  
QID: B1

Which one of the following describes the operation of a safety valve installed on a high pressure steam system?

- A. A safety valve is initially lifted off its seat by system pressure, then is forced fully open by an air-operated piston.
- B. As system pressure increases to the safety valve setpoint, the pressure overcomes spring force on the valve operator, causing the valve to open.
- C. A safety valve will remain open until system pressure has been reduced to the pilot valve actuation setpoint.
- D. When the open safety valve has returned system pressure to the lifting set point, a combination of air and steam pressure above the valve disk closes the valve.

ANSWER: B.

TOPIC: 291001  
KNOWLEDGE: K1.01 [3.4/3.5]  
QID: B901

Which one of the following valves provides overpressure protection to limit the internal pressure in vessels, and thus protect personnel and equipment?

- A. Safety
- B. Control
- C. Sentinel
- D. Pressure regulating

ANSWER: A.

TOPIC: 291001  
KNOWLEDGE: K1.01 [3.4/3.5]  
QID: B1101

Which one of the following statements describes the operation of a reactor pressure vessel safety valve?

- A. An open safety valve will close when reactor pressure decreases enough for gravity and spring tension to overcome the effect of reactor pressure on the main valve disk.
- B. An open safety valve will close when the pilot valve senses a reduced reactor pressure and isolates reactor pressure to the main valve disk.
- C. When reactor pressure reaches the lift set point, the safety valve begins to open and will modulate to a position that is directly proportional to reactor pressure.
- D. When reactor pressure reaches the lift set point, a pilot valve closes to create a differential pressure across the main valve disk, which overcomes gravity and spring tension to open the valve.

ANSWER: A.

TOPIC: 291001  
KNOWLEDGE: K1.01 [3.4/3.5]  
QID: B1701 (P1802)

A vertical safety valve has a compressed spring assembly that is applying 1,200 lbf to the top of the valve disk in opposition to system pressure. System pressure is being exerted on the underside of the valve disk that is 3 inches in diameter.

Which one of the following is the approximate system pressure at which the safety valve will open?

- A. 44 psig
- B. 64 psig
- C. 128 psig
- D. 170 psig

ANSWER: D.

TOPIC: 291001  
KNOWLEDGE: K1.01 [3.4/3.5]  
QID: B2003 (P1903)

A vertical safety valve with a 3-inch diameter disk has a spring applying 1,000 lbf to the top of the valve disk in opposition to system pressure. Which one of the following is the approximate system pressure at which the safety valve will begin to open?

- A. 35 psig
- B. 111 psig
- C. 141 psig
- D. 444 psig

ANSWER: C.

TOPIC: 291001  
KNOWLEDGE: K1.01 [3.4/3.5]  
QID: B2103 (P2101)

Refer to the drawing of a typical safety valve (see figure below).

The component indicated by the solid arrow is used when necessary to manually...

- A. ratchet open the safety valve.
- B. pop open the safety valve.
- C. gag shut the safety valve.
- D. determine the position of the safety valve.

ANSWER: B.

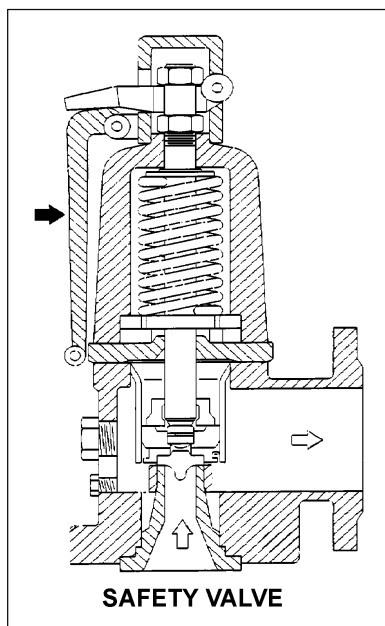

TOPIC: 291001  
KNOWLEDGE: K1.01 [3.4/3.5]  
QID: B2301 (P2301)

A vertical safety valve has a compressed spring assembly that is applying 2,500 lbf to the top of the valve disk in opposition to system pressure. System pressure is being exerted on the underside of the valve disk that is 5 inches in diameter.

Which one of the following is the approximate system pressure at which the safety valve will open?

- A. 32 psig
- B. 127 psig
- C. 159 psig
- D. 500 psig

ANSWER: B.

TOPIC: 291001  
KNOWLEDGE: K1.01 [3.4/3.5]  
QID: B2803 (P2801)

A vertical safety valve with a 2-inch diameter disk has a compressed spring applying 2,400 lbf to the top of the valve disk in opposition to system pressure. Which one of the following is the approximate system pressure at which the safety valve will open?

- A. 95 psig
- B. 191 psig
- C. 382 psig
- D. 764 psig

ANSWER: D.

TOPIC: 291001  
KNOWLEDGE: K1.01 [3.4/3.5]  
QID: B3401 (P3401)

Given the following pressure specifications for operation of a main steam safety valve (MSSV):

Setpoint pressure (MSSV starts to open) = 1,200 psia  
Maximum pressure (MSSV will be fully open) = 1,230 psia  
Reseat pressure (MSSV will be fully closed) = 1,140 psia

Which one of the following is the percent blowdown for the MSSV?

- A. 2.5 percent
- B. 5.0 percent
- C. 7.5 percent
- D. 10.0 percent

ANSWER: B.

TOPIC: 291001  
KNOWLEDGE: K1.01 [3.4/3.5]  
K1.02 [3.4/3.6]  
QID: B4201 (P4201)

A completely full water storage tank is being hydrostatically tested to 100 psig using a positive displacement pump (PDP) with a smooth and constant discharge flow rate of 10 gpm. The tank is protected by a safety valve and a relief valve; both valves discharge to the atmosphere. Each valve has an opening setpoint of 105 psig and a maximum rated discharge flow rate of 6 gpm. The PDP is inadvertently left running when tank pressure reaches 100 psig.

With the PDP still running, tank pressure will stabilize \_\_\_\_\_ 105 psig; and the greater mass flow rate will be coming from the \_\_\_\_\_ valve.

- A. at; safety
- B. above; safety
- C. at; relief
- D. above; relief

ANSWER: B.

TOPIC: 291001  
KNOWLEDGE: K1.01 [3.4/3.5]  
QID: B4401 (P4401)

Given the following pressure specifications for a safety relief valve (SRV):

Setpoint pressure (SRV will start to open) = 1,200 psia  
Maximum pressure (SRV will be fully open) = 1,242 psia  
Reseat pressure (SRV will be fully closed) = 1,152 psia

Which one of the following is the percent accumulation for the SRV?

- A. 2.5 percent
- B. 3.0 percent
- C. 3.5 percent
- D. 4.0 percent

ANSWER: C.

TOPIC: 291001  
KNOWLEDGE: K1.01 [3.4/3.5]  
K1.02 [3.4/3.6]  
QID: B4701 (P4701)

A completely full water storage tank is being hydrostatically tested to 200 psig using a positive displacement pump (PDP) with a smooth and constant discharge flow rate of 8 gpm. The tank is protected by a relief valve and a safety valve; both valves discharge to the atmosphere. Each valve has an opening setpoint of 205 psig and a maximum rated discharge flow rate of 6 gpm. The PDP is inadvertently left running when tank pressure reaches 200 psig.

When conditions stabilize with the PDP still running, the relief valve will be \_\_\_\_\_ open; and the safety valve will be discharging a flow rate of approximately \_\_\_\_\_ to the atmosphere.

- A. partially; 6 gpm
- B. partially; 2 gpm
- C. fully; 6 gpm
- D. fully; 2 gpm

ANSWER: A.



TOPIC: 291001  
KNOWLEDGE: K1.01 [3.4/3.5]  
K1.02 [3.4/3.6]  
QID: B5201 (P5201)

Refer to the drawing of two identical water storage tanks (see figure below). Tank A is protected by a relief valve and Tank B is protected by a safety valve. Each valve has an opening setpoint of 205 psig and a maximum rated discharge flow rate of 8 gpm.

The tanks are being hydrostatically tested to 200 psig. Each tank is being supplied with a smooth and constant flow rate of 2 gpm from separate positive displacement pumps (PDPs). Both PDPs are inadvertently left running when tank pressures reach 200 psig.

With the PDPs running continuously, what will be the resulting status of the relief and safety valves?

- | <u>Relief Valve Status</u>                     | <u>Safety Valve Status</u>                  |
|--|---|
| A. Partially open                              | Partially open                              |
| B. Partially open                              | Cycling between fully open and fully closed |
| C. Cycling between fully open and fully closed | Partially open                              |
| D. Cycling between fully open and fully closed | Cycling between fully open and fully closed |

ANSWER: B.

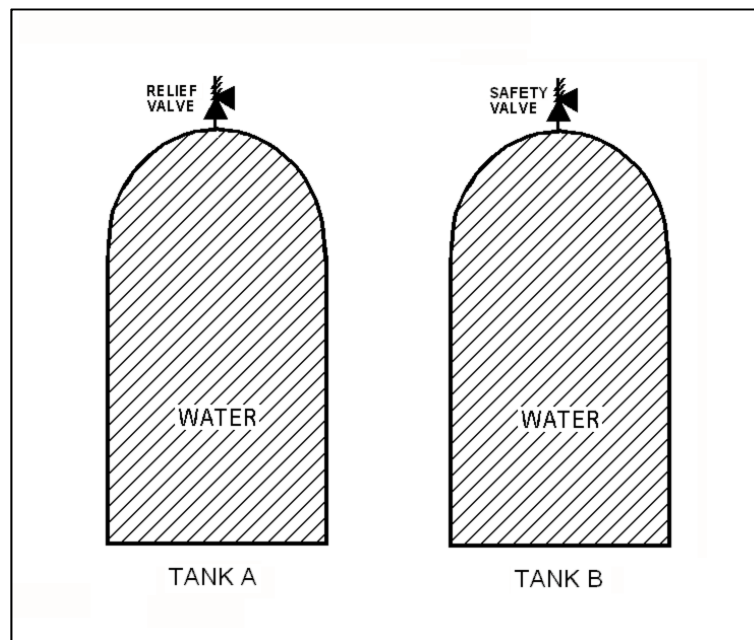

TOPIC: 291001  
KNOWLEDGE: K1.01 [3.4/3.5]  
              K1.02 [3.4/3.6]  
QID: B6101 (P6101)

A completely full water storage tank is being hydrostatically tested to 200 psig using a positive displacement pump (PDP) with a smooth and constant discharge flow rate of 8 gpm. The tank is protected by a relief valve and a safety valve that both discharge to the atmosphere. The valves have the following characteristics:

- The relief valve opening setpoint is 200 psig with an accumulation of 5 percent.
- The safety valve opening setpoint is 240 psig with a blowdown of 5 percent.
- Both valves have a maximum discharge flow rate of 6 gpm.

The PDP is inadvertently left running when tank pressure reaches 200 psig.

When conditions stabilize with the PDP still running, the relief valve will be \_\_\_\_\_ open; and the safety valve will be discharging a flow rate of approximately \_\_\_\_\_ to the atmosphere.

- A. partially; 6 gpm
- B. partially; 2 gpm
- C. fully; 6 gpm
- D. fully; 2 gpm

ANSWER: D.

TOPIC: 291001  
KNOWLEDGE: K1.01 [3.4/3.5]  
K1.02 [3.4/3.6]  
QID: B6201 (P6201)

A main steam system uses a combination of safety and relief valves for overpressure protection. Which one of the following describes a major design consideration for installing both types of valves in the same system?

- A. The safety valves are installed to prevent chattering of the relief valves during normal power operation.
- B. The safety valves are installed to prevent unnecessary opening of the relief valves during a steam pressure transient.
- C. The relief valves are installed to prevent chattering of the safety valves during normal power operation.
- D. The relief valves are installed to prevent unnecessary opening of the safety valves during a steam pressure transient.

ANSWER: D.

TOPIC: 291001  
KNOWLEDGE: K1.01 [3.4/3.5]  
K1.02 [3.4/3.6]  
QID: B7671 (P7671)

A completely full water storage tank is being hydrostatically tested to 200 psig using a positive displacement pump (PDP) with a smooth and constant discharge flow rate of 8 gpm. The tank is protected by a relief valve and a safety valve that both discharge to the atmosphere. The valves have the following characteristics:

- The relief valve opening setpoint is 220 psig with an accumulation of 5 percent.
- The safety valve opening setpoint is 260 psig with a blowdown of 5 percent.
- Both valves have a maximum discharge flow rate of 6 gpm.

The PDP is inadvertently left running when tank pressure reaches 200 psig.

After a few minutes with the PDP still running, the relief valve will be discharging a flow rate of approximately \_\_\_\_\_; and the safety valve will be \_\_\_\_\_.

- A. 2 gpm; partially open
- B. 6 gpm; partially open
- C. 2 gpm; cycling between fully open and fully closed
- D. 6 gpm; cycling between fully open and fully closed

ANSWER: D.

TOPIC: 291001  
KNOWLEDGE: K1.02 [3.4/3.6]  
QID: B2 (P3302)

Refer to the drawing of two identical pressure vessels with identical relief valve protection (see figure below).

Vessel A is completely filled with subcooled water at 80°F and vessel B is in a saturated, two-phase condition. Both vessels are currently pressurized to 50 psig and isolated.

If both relief valves fully open simultaneously, the faster pressure reduction will initially occur in vessel \_\_\_\_; and the faster mass loss will initially occur in vessel \_\_\_\_.

- A. A; A
- B. A; B
- C. B; A
- D. B; B

ANSWER: A.

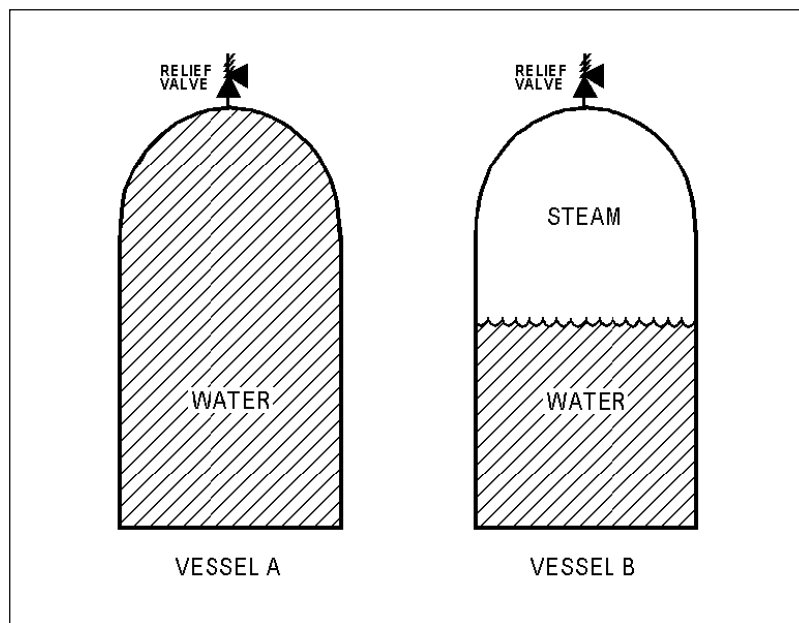

TOPIC: 291001  
KNOWLEDGE: K1.02 [3.4/3.5]  
QID: B201 (P501)

The difference between the setpoint pressure at which a relief valve begins to open and the pressure at which it is fully open is called...

- A. setpoint deviation.
- B. setpoint tolerance.
- C. accumulation.
- D. blowdown.

ANSWER: C.

TOPIC: 291001  
KNOWLEDGE: K1.02 [3.4/3.6]  
QID: B301 (P202)

The difference between the setpoint pressure at which a safety valve opens and the pressure at which it closes is called...

- A. blowdown.
- B. accumulation.
- C. setpoint tolerance.
- D. setpoint deviation.

ANSWER: A.

TOPIC: 291001  
KNOWLEDGE: K1.02 [3.4/3.6]  
QID: B1301 (P1801)

Refer to the drawing of two identical pressure vessels with identical relief valve protection (see figure below).

Both vessels have been pressurized to 50 psig and then isolated. Vessel A is completely filled with water at 150°F. Vessel B is in a saturated condition with one-half steam (100 percent quality) and one-half water (0 percent quality) by volume.

If both relief valves fully open simultaneously, the faster pressure reduction will occur in vessel \_\_\_\_\_; and if both relief valves close at 40 psig, the greater mass loss will have occurred in vessel \_\_\_\_\_.

- A. A; A
- B. A; B
- C. B; A
- D. B; B

ANSWER: B.

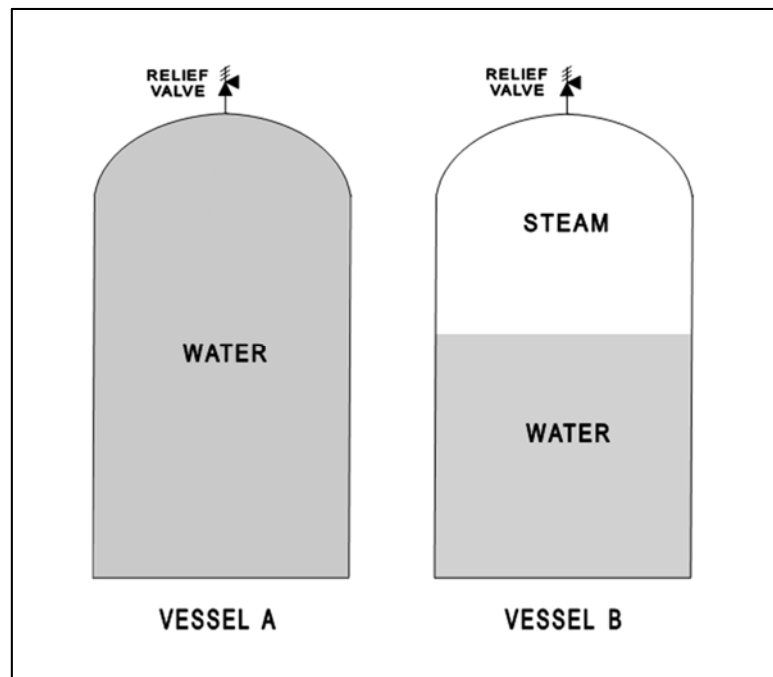

TOPIC: 291001  
KNOWLEDGE: K1.02 [3.4/3.6]  
QID: B1801 (P1504)

Which one of the following is a difference between a typical relief valve and a typical safety valve?

- A. The actuator closing spring on a relief valve is in a compressed state whereas the actuator closing spring on a safety valve acts in tension.
- B. A relief valve gradually opens as pressure increases above the setpoint pressure whereas a safety valve pops open at the setpoint pressure.
- C. Relief valves are capable of being gagged whereas safety valves are not.
- D. The blowdown of a relief valve is greater than the blowdown of a safety valve.

ANSWER: B.

TOPIC: 291001  
KNOWLEDGE: K1.02 [3.4/3.6]  
QID: B2501 (P2501)

Water storage tanks A and B are identical except that tank A receives overpressure protection from a relief valve, whereas tank B uses a safety valve. The relief valve and safety valve have the same pressure setpoints and design flow rates.

Water is continuously added to each tank at the same rate (50 percent of the design flow rate of the relief and safety valves). After the tanks are completely full, tank A pressure will \_\_\_\_\_; and tank B pressure will \_\_\_\_\_.

- A. fluctuate within a few percent of the pressure setpoint; stabilize slightly above the pressure setpoint
- B. fluctuate within a few percent of the pressure setpoint; fluctuate within a few percent of the pressure setpoint
- C. stabilize slightly above the pressure setpoint; stabilize slightly above the pressure setpoint
- D. stabilize slightly above the pressure setpoint; fluctuate within a few percent of the pressure setpoint

ANSWER: D.



TOPIC: 291001  
KNOWLEDGE: K1.02 [3.4/3.6]  
QID: B2701 (P2701)

Vessels A and B are identical except that vessel A receives overpressure protection from an installed safety valve. Vessel B has an installed relief valve. The safety and relief valves have the same pressure setpoint and design flow rate.

Water is continuously added to each vessel at the same rate (50 percent of the design flow rate of the safety and relief valves). After vessel pressure reaches the setpoint for each valve, vessel A pressure will \_\_\_\_\_; and vessel B pressure will \_\_\_\_\_.

- A. stabilize slightly above the pressure setpoint; stabilize slightly above the pressure setpoint
- B. stabilize slightly above the pressure setpoint; fluctuate within a few percent of the pressure setpoint
- C. fluctuate within a few percent of the pressure setpoint; stabilize slightly above the pressure setpoint
- D. fluctuate within a few percent of the pressure setpoint; fluctuate within a few percent of the pressure setpoint

ANSWER: C.

TOPIC: 291001  
KNOWLEDGE: K1.02 [3.4/3.6]  
QID: B6402 (P6401)

A completely full water storage tank is being hydrostatically tested to 200 psig using a positive displacement pump (PDP) with a smooth and constant discharge flow rate of 6 gpm. The tank is protected by two relief valves that discharge to the atmosphere. The relief valves have the following characteristics:

- Relief valve A opening setpoint is 200 psig with an accumulation of 1.5 percent.
- Relief valve B opening setpoint is 200 psig with an accumulation of 3.0 percent.
- Each valve has linear flow rate characteristics and a maximum discharge flow rate of 6 gpm.

The PDP is inadvertently left running when tank pressure reaches 200 psig.

With the PDP running continuously, what will be the discharge flow rates of the relief valves when tank pressure stabilizes?

	Relief <u>Valve A</u>	Relief <u>Valve B</u>
A.	1 gpm	5 gpm
B.	2 gpm	4 gpm
C.	3 gpm	3 gpm
D.	4 gpm	2 gpm

ANSWER: D.

TOPIC: 291001  
KNOWLEDGE: K1.02 [3.4/3.6]  
QID: B6701 (P6701)

A completely full water tank is being hydrostatically tested to 180 psig using a positive displacement pump (PDP) with a smooth and constant discharge flow rate of 6 gpm. The tank is protected by two relief valves that discharge to the atmosphere. The relief valves have the following characteristics:

- Relief valve A opening setpoint is 180 psig with an accumulation of 5 percent.
- Relief valve B opening setpoint is 200 psig with an accumulation of 5 percent.
- Each relief valve has linear flow rate characteristics and a maximum flow rate of 4 gpm.

The PDP is inadvertently left running when tank pressure reaches 180 psig.

With the PDP still running, at what pressure will the tank stabilize?

- A. 190 psig
- B. 195 psig
- C. 205 psig
- D. 210 psig

ANSWER: C.

TOPIC: 291001  
KNOWLEDGE: K1.02 [3.4/3.6]  
QID: B7611 (P7611)

A completely full water storage tank is being hydrostatically tested to 200 psig using a positive displacement pump (PDP) with a smooth and constant discharge flow rate of 4 gpm. The tank is protected by a relief valve that discharges to the atmosphere. The relief valve has the following characteristics:

- The opening setpoint is 200 psig with an accumulation of 5 percent.
- The valve has linear flow characteristics and a maximum rated flow rate of 8 gpm.

The PDP is inadvertently left running when tank pressure reaches 200 psig.

With the PDP still running, at what pressure will the tank stabilize?

- A. 190 psig
- B. 195 psig
- C. 205 psig
- D. 210 psig

ANSWER: C.

TOPIC: 291001  
KNOWLEDGE: K1.02 [3.4/3.6]  
QID: B7711 (P7711)

A completely full water storage tank is being hydrostatically tested to 300 psig using a positive displacement pump (PDP) with a smooth and constant discharge flow rate of 4 gpm. The tank is protected by a relief valve that discharges to the atmosphere. The relief valve has the following characteristics:

- The relief valve opening setpoint is 300 psig with an accumulation of 5 percent.
- The relief valve has linear flow characteristics and a maximum rated flow rate of 6 gpm.

The PDP is inadvertently left running when tank pressure reaches 300 psig.

With the PDP still running, at what pressure will the tank stabilize?

- A. 305 psig
- B. 310 psig
- C. 315 psig
- D. 320 psig

ANSWER: B.

TOPIC: 291001  
KNOWLEDGE: K1.02 [3.4/3.6]  
QID: B7731 (P7731)

A cooling water system uses a conventional relief valve (not pilot-operated) with a bench-tested setpoint of 60 psig. The relief valve discharges to a collection tank that is maintained at 5 psig. At what system pressure will the relief valve begin to open?

- A. 55 psig
- B. 60 psig
- C. 65 psig
- D. 80 psig

ANSWER: C.

TOPIC: 291001  
KNOWLEDGE: K1.03 [2.7/2.8]  
QID: B202

If a pressure control valve at the outlet of a heat exchanger opens farther, system flow rate will \_\_\_\_\_; and system head loss will \_\_\_\_\_.

- A. increase; decrease
- B. increase; increase
- C. decrease; decrease
- D. decrease; increase

ANSWER: A.

TOPIC: 291001  
KNOWLEDGE: K1.03 [2.7/2.8]  
QID: B2101 (P2102)

Which one of the following statements describes the flow rate characteristics of a typical gate valve in an operating water system?

- A. The first 25 percent of valve disk travel in the open direction will produce a smaller change in flow rate than the last 25 percent of valve disk travel.
- B. The first 25 percent of valve disk travel in the open direction will produce a greater change in flow rate than the last 25 percent of valve disk travel.
- C. The first 25 percent of valve disk travel in the open direction will produce approximately the same change in flow rate as the last 25 percent of valve disk travel.
- D. A gate valve that has been opened to 25 percent of valve disk travel will result in approximately 25 percent of full flow rate.

ANSWER: B.

TOPIC: 291001  
KNOWLEDGE: K1.03 [3.4/3.6]  
QID: B2205 (P405)

Consider a typical gate valve and a typical globe valve in the same water system application. The globe valve generally has a \_\_\_\_\_ pressure drop when fully open; and is \_\_\_\_\_ commonly used for throttling system flow.

- A. smaller; less
- B. larger; more
- C. smaller; more
- D. larger; less

ANSWER: B.

TOPIC: 291001  
KNOWLEDGE: K1.03 [2.7/2.8]  
QID: B2303 (P2303)

A control valve is most likely to experience cavitation when the valve is almost fully \_\_\_\_\_ because of a relatively \_\_\_\_\_ pressure drop across the valve seat.

- A. open; large
- B. open; small
- C. closed; large
- D. closed; small

ANSWER: C.

TOPIC: 291001  
KNOWLEDGE: K1.03 [2.7/2.8]  
QID: B2601 (P2302)

Which one of the following statements describes the flow rate characteristics of a typical globe valve in an operating water system?

- A. The first 25 percent of valve disk travel in the open direction will produce a smaller increase in flow rate than the last 25 percent of valve disk travel.
- B. The first 25 percent of valve disk travel in the open direction will produce a greater increase in flow rate than the last 25 percent of valve disk travel.
- C. The first 25 percent of valve disk travel in the open direction will produce approximately the same increase in flow rate as the last 25 percent of valve disk travel.
- D. A globe valve that has been opened to 25 percent of valve disk travel will result in approximately 25 percent of full flow rate.

ANSWER: B.

TOPIC: 291001  
KNOWLEDGE: K1.03 [2.7/2.8]  
QID: B3002 (P3001)

Which one of the following statements describes the throttling characteristics of a typical globe valve?

- A. The first third of valve disk travel in the open direction will result in approximately one-third of full flow rate.
- B. The first third of valve disk travel in the open direction will produce a smaller increase in flow rate than the last third of valve disk travel.
- C. The first third of valve disk travel in the open direction will produce a greater increase in flow rate than the last third of valve disk travel.
- D. The first two-thirds of valve disk travel in the open direction will produce approximately the same increase in flow rate as the last third of valve disk travel.

ANSWER: C.



TOPIC: 291001  
KNOWLEDGE: K1.03 [2.7/2.8]  
QID: B3902 (P3901)

Refer to the drawing of a cooling water system in which both centrifugal pumps A and B are operating (see figure below).

An operator stops pump B, but the pump B check valve fails to close. In comparison to normal operation with only pump A running, operation with the failed pump B check valve will result in pump A flow rate being \_\_\_\_\_ than normal; and heat exchanger flow rate being \_\_\_\_\_ than normal.

- A. higher; higher
- B. higher; lower
- C. lower; higher
- D. lower; lower

ANSWER: B.

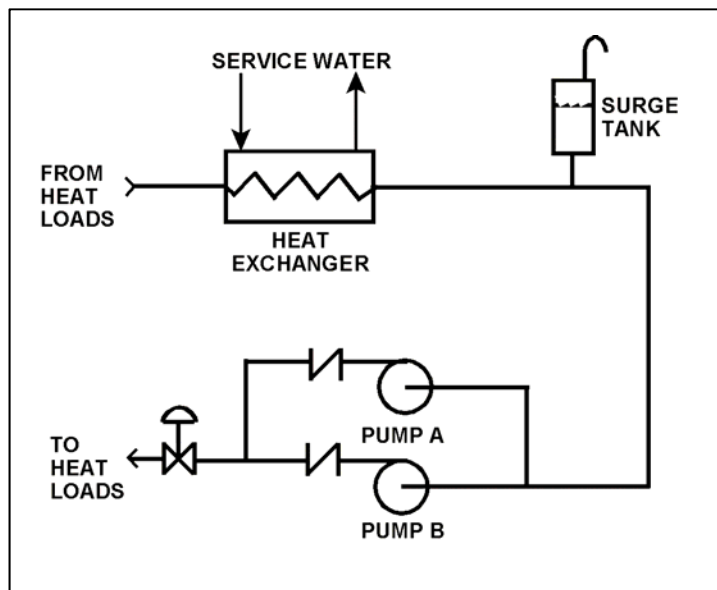

TOPIC: 291001  
KNOWLEDGE: K1.03 [2.7/2.8]  
QID: B4103 (P4101)

Which one of the following types of similarly sized valves in an operating water system produces the least frictional head loss when fully open?

- A. Ball
- B. Globe
- C. Butterfly
- D. Swing check

ANSWER: A.

TOPIC: 291001  
KNOWLEDGE: K1.03 [2.7/2.8]  
QID: B4802 (P4801)

Refer to the centrifugal pump operating curve with two system head loss curves (see figure below). The curves apply to an open cooling water system using one single-speed centrifugal pump discharging through a typical flow control valve.

One of the system curves shows system head loss with the flow control valve 25 percent open. The other system curve shows system head loss with the flow control valve 100 percent open. The pump is initially operating with the valve 25 percent open, resulting in a pump flow rate of 800 gpm.

If the flow control valve is subsequently fully opened, pump flow rate through the valve will be approximately...

- A. 400 gpm.
- B. 1,200 gpm.
- C. 1,600 gpm.
- D. 3,200 gpm.

ANSWER: B.

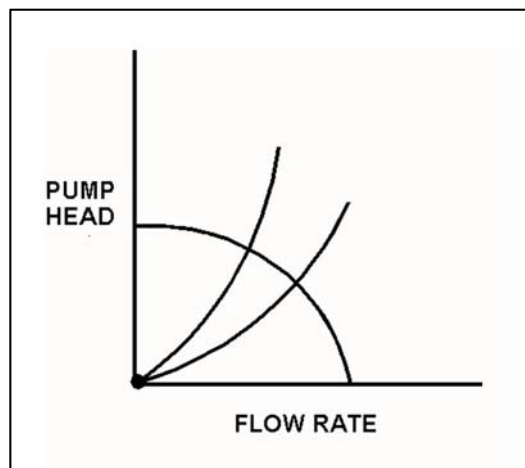

TOPIC: 291001  
KNOWLEDGE: K1.03 [2.7/2.8]  
QID: B4901 (P4901)

Consider a 6-inch globe valve and a 6-inch gate valve in the same water system application. Typically, the valve that requires the most linear disk travel from fully closed to fully open is the \_\_\_\_\_ valve; and the valve that produces the smallest pressure drop when fully open is the \_\_\_\_\_ valve.

- A. gate; gate
- B. gate; globe
- C. globe; gate
- D. globe; globe

ANSWER: A.

TOPIC: 291001  
KNOWLEDGE: K1.03 [2.7/2.8]  
QID: B6001 (P6001)

Subcooled water was flowing through a throttled valve with the following initial parameters:

Inlet pressure = 60 psia  
Outlet pressure = 50 psia  
Flow rate = 800 gpm

The valve was opened fully and the following parameters currently exist:

Inlet pressure = 60 psia  
Outlet pressure = 55 psia

What is the approximate flow rate through the fully open valve?

- A. 400 gpm
- B. 566 gpm
- C. 635 gpm
- D. Cannot be determined without additional information.

ANSWER: D.

TOPIC: 291001  
KNOWLEDGE: K1.03 [2.7/2.8]  
QID: B6601 (P6601)

Subcooled water is flowing through a throttle valve in an open system. The initial steady-state conditions for the throttle valve are as follows:

Inlet pressure = 60 psia  
Outlet pressure = 44 psia  
Flow rate = 800 gpm

Four hours later, the current steady-state conditions for the throttle valve are as follows:

Inlet pressure = 63 psia  
Outlet pressure = 54 psia  
Flow rate = 600 gpm

Which one of the following could be responsible for the difference between the initial and current conditions for the throttle valve?

- A. The throttle valve was opened more.
- B. The throttle valve was closed more.
- C. Another valve, located upstream of the throttle valve, was partially closed.
- D. Another valve, located downstream of the throttle valve, was partially closed.

ANSWER: D.

TOPIC: 291001  
KNOWLEDGE: K1.03 [2.7/2.8]  
QID: B7302 (P7302)

Subcooled water is flowing through a throttled valve in an open system. The initial steady-state conditions for the throttled valve are as follows:

Inlet pressure = 60 psia  
Outlet pressure = 44 psia  
Flow rate = 800 gpm

After four hours, the current steady-state conditions for the throttled valve are as follows:

Inlet pressure = 62 psia  
Outlet pressure = 40 psia  
Flow rate = 600 gpm

Which one of the following could be responsible for the difference between the initial and current steady-state conditions for the throttled valve?

- A. The throttled valve was opened more.
- B. The throttled valve was closed more.
- C. Another valve, located upstream of the throttled valve, was partially closed.
- D. Another valve, located downstream of the throttled valve, was partially closed.

ANSWER: B.

TOPIC: 291001  
KNOWLEDGE: K1.03 [2.7/2.8]  
QID: B7601 (P7601)

Refer to the drawing of an operating cooling water system (see figure below) in which valves A and B are identical. Valve A is one-half open and valve B is fully open. If valve A is opened fully, the differential pressure (D/P) across valve B will...

- A. increase by the same amount as the absolute change in D/P across valve A.
- B. increase by an amount less than the absolute change in D/P across valve A.
- C. decrease by the same amount as the absolute change in D/P across valve A.
- D. decrease by an amount less than the absolute change in D/P across valve A.

ANSWER: B.

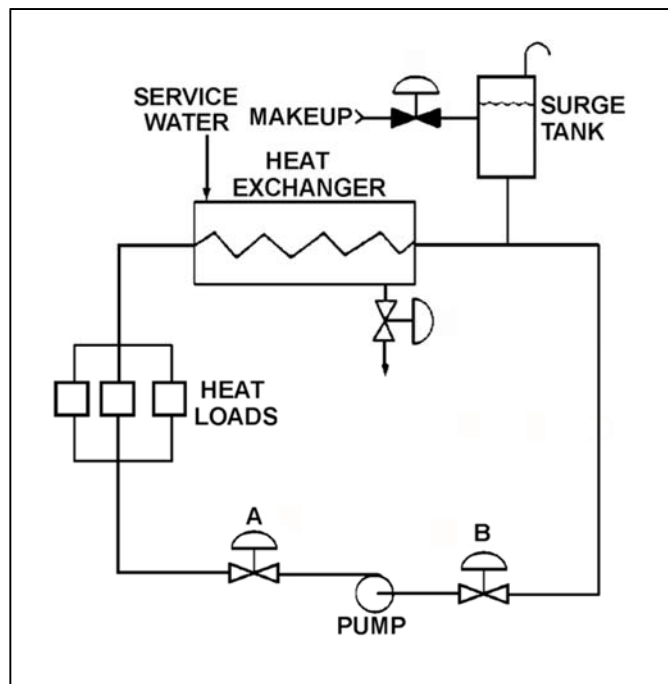

TOPIC: 291001  
KNOWLEDGE: K1.03 [2.7/2.8]  
QID: B7641 (P7641)

Consider a 6-inch globe valve and a 6-inch gate valve in the same water system application. The valve that typically requires the least linear travel of the disk from fully closed to fully open is the \_\_\_\_\_ valve; and the valve that produces the greatest pressure drop when fully open is the \_\_\_\_\_ valve.

- A. gate; gate
- B. gate; globe
- C. globe; gate
- D. globe; globe

ANSWER: D.



TOPIC: 291001  
KNOWLEDGE: K1.03 [2.7/2.8]  
QID: B7661 (P7661)

Subcooled water is flowing through a throttle valve in an open system. The initial steady-state conditions for the throttle valve are as follows:

Inlet pressure = 60 psia  
Outlet pressure = 44 psia  
Flow rate = 800 gpm

Four hours later, the current steady-state conditions for the throttle valve are as follows:

Inlet pressure = 51 psia  
Outlet pressure = 42 psia  
Flow rate = 600 gpm

Which one of the following could be responsible for the difference between the initial and current conditions for the throttle valve?

- A. The throttle valve was opened more.
- B. The throttle valve was closed more.
- C. Another valve, located upstream of the throttle valve, was partially closed.
- D. Another valve, located downstream of the throttle valve, was partially closed.

ANSWER: C.

TOPIC: 291001  
KNOWLEDGE: K1.03 [2.7/2.8]  
QID: B7741 (P7741)

Subcooled water is flowing through a throttle valve in an open system. The initial steady-state conditions for the throttle valve are as follows:

Inlet pressure = 60 psia  
Outlet pressure = 44 psia  
Flow rate = 800 gpm

After four hours, the current steady-state conditions for the throttle valve are as follows:

Inlet pressure = 58 psia  
Outlet pressure = 46 psia  
Flow rate = 1,000 gpm

Which one of the following could be responsible for the difference between the initial and current steady-state conditions for the throttle valve?

- A. The throttle valve was closed more.
- B. The throttle valve was opened more.
- C. Another valve, located upstream of the throttle valve, was opened more.
- D. Another valve, located downstream of the throttle valve, was opened more.

ANSWER: B.

TOPIC: 291001  
KNOWLEDGE: K1.04 [2.7/2.8]  
QID: B502 (P203)

Refer to the drawing of a hydraulically-operated valve that is shown in a throttled position (see figure below).

Select the final position of this valve following a loss of hydraulic system pressure.

- A. Fully open
- B. As is
- C. Fully closed
- D. Midposition

ANSWER: A.

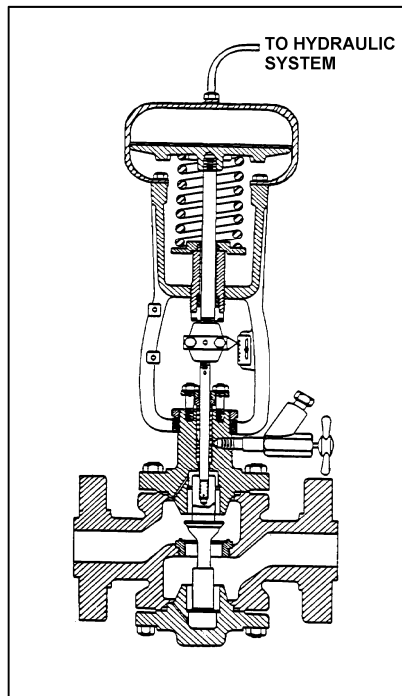

TOPIC: 291001  
KNOWLEDGE: K1.04 [2.7/2.8]  
QID: B602 (P1202)

How will a typical motor-operated valve respond to a loss of electrical power to the valve actuator?

- A. Open fully
- B. Close fully
- C. Remain as is
- D. Move to 50 percent open

ANSWER: C.

TOPIC: 291001  
KNOWLEDGE: K1.04 [2.7/2.8]  
QID: B1002 (P2104)

Refer to the drawing of a spring-loaded air-operated valve shown in a throttled position (see figure below).

Which one of the following will be the valve position following a reduction in air pressure to the valve actuator caused by a leaking air connection at the valve?

- A. Original position
- B. More closed
- C. More open
- D. Varies with system flow

ANSWER: B.

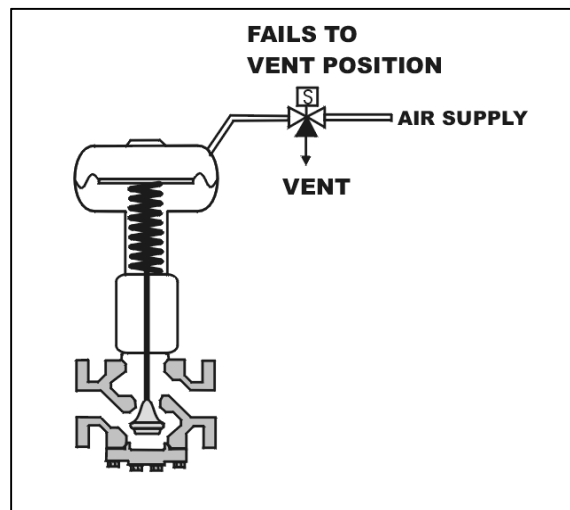

TOPIC: 291001  
KNOWLEDGE: K1.04 [2.7/2.8]  
QID: B1109 (P1101)

Refer to the drawing of a spring-loaded air-operated valve shown in a throttled position (see figure below).

The figure currently depicts normal air supply pressure and an energized solenoid. What will be the valve position following a loss of electrical power to the solenoid?

- A. As is
- B. More open
- C. More closed
- D. Varies with system flow

ANSWER: B.

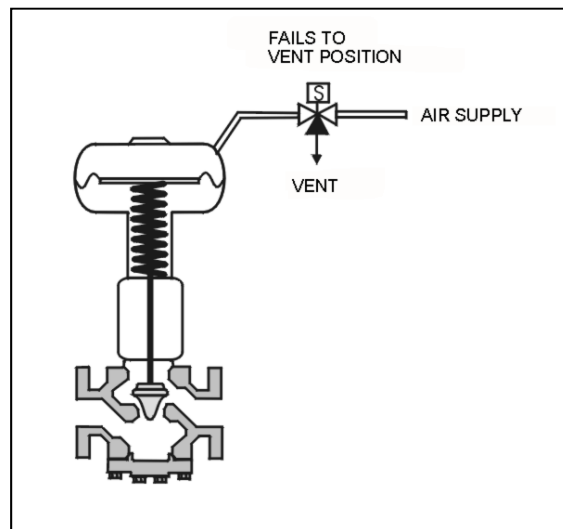

TOPIC: 291001  
KNOWLEDGE: K1.04 [2.7/2.8]  
QID: B1401 (P112)

Refer to the drawing of a spring-loaded air-operated valve (see figure below) in which the solenoid is shown energized.

Which one of the following will be the final valve position following a loss of electrical power to the solenoid?

- A. Midposition
- B. Closed
- C. As is
- D. Open

ANSWER: B.

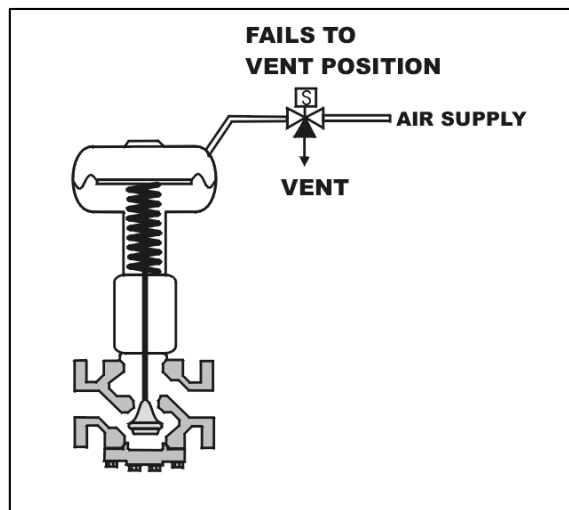

TOPIC: 291001  
KNOWLEDGE: K1.04 [2.7/2.8]  
QID: B1903 (P101)

Refer to the drawing of a spring-loaded air-operated valve (see figure below).

Upon a loss of air pressure, this valve will...

- A. go to the fully open position.
- B. remain at the current position.
- C. go to the fully closed position.
- D. go to the midposition.

ANSWER: C.

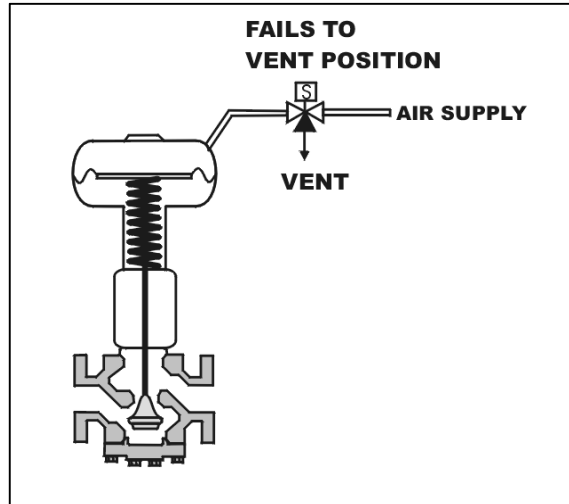



TOPIC: 291001  
KNOWLEDGE: K1.04 [2.7/2.8]  
QID: B5002 (P5002)

Refer to the drawing of a pneumatically-operated valve (see figure below). The valve actuator may be shown with or without air pressure applied to it.

Which one of the following describes the type of valve shown, and the fail position on loss of air to the actuator?

- |    | <u>Valve Type</u> | <u>Fail Position</u> |
|----|-------------------|----------------------|
| A. | Gate              | Open                 |
| B. | Gate              | Closed               |
| C. | Globe             | Open                 |
| D. | Globe             | Closed               |

ANSWER: C.

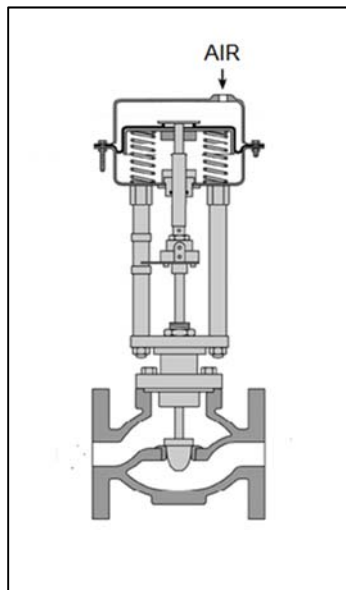

TOPIC: 291001  
KNOWLEDGE: K1.04 [2.7/2.8]  
QID: B5301 (P5302)

Refer to the drawing of four air-operated valves (see figure below). **Note:** The valve actuators may be shown with or without air pressure applied.

Given:

- The direction of system flow is from left to right when the valves are open.
- The internal components for each valve are identical except for the orientation of the valve disk and seat.
- The valve actuators exert the same force on the attached valve stem for a given applied air pressure.

If each actuator is vented, which valve disk will remain closed with the most force?

- A. A.
- B. B.
- C. C.
- D. D.

ANSWER: C.

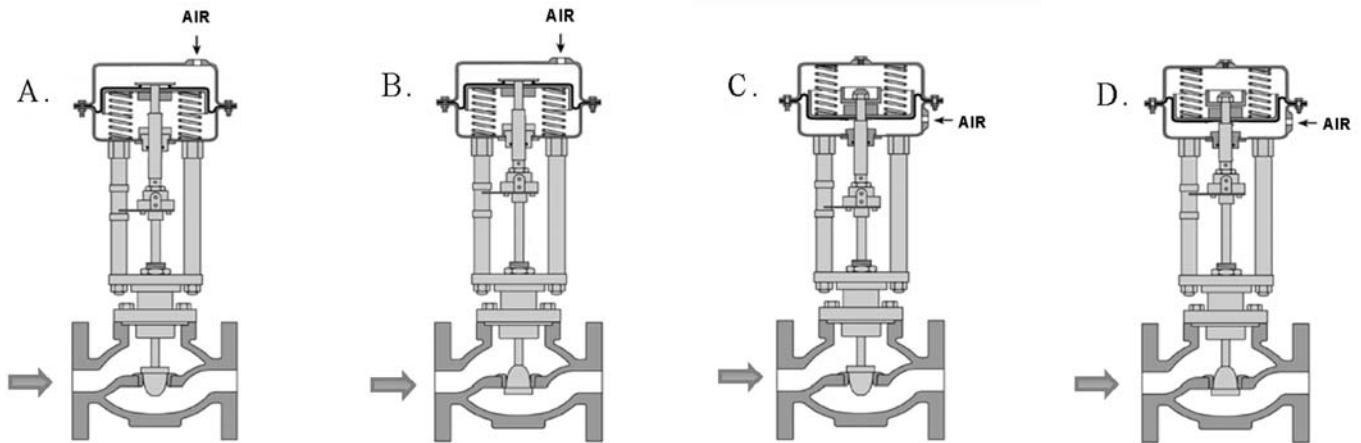

TOPIC: 291001  
KNOWLEDGE: K1.04 [2.7/2.8]  
QID: B5502 (P5502)

Refer to the drawing of four air-operated valves (see figure below). **Note:** The valve actuators may be shown with or without air pressure applied.

Which valves are currently shown in their failed (i.e., no air pressure applied to the actuator) positions?

- A. A and B
- B. B and C
- C. C and D
- D. D and A

ANSWER: B.

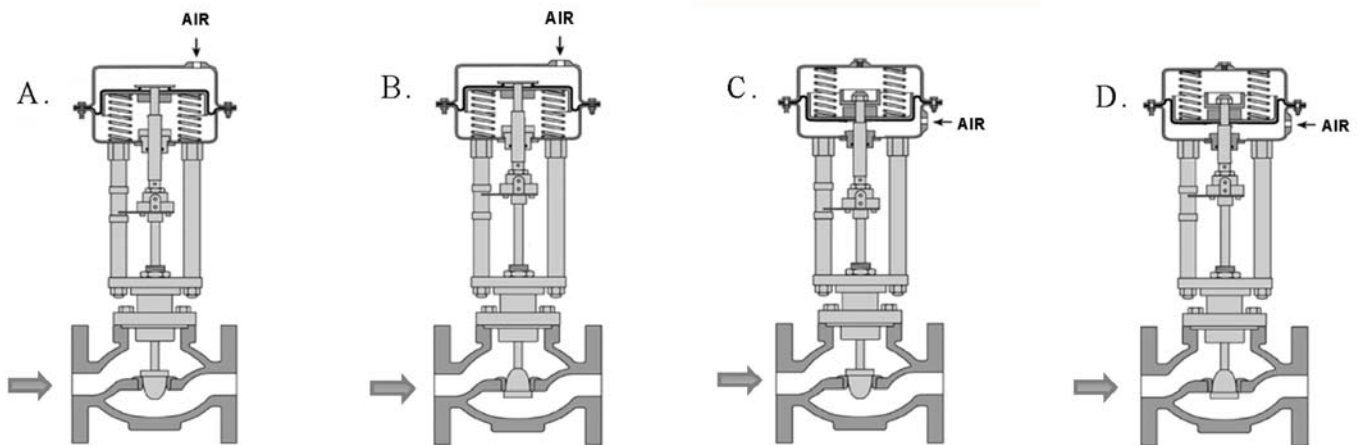

TOPIC: 291001  
KNOWLEDGE: K1.04 [2.7/2.8]  
QID: B5902 (P5901)

Refer to the drawing of a pneumatically-operated valve (see figure below). The valve actuator may be shown with or without applied air pressure.

Which one of the following describes the type of valve shown, and the valve's fail position on loss of air to the actuator?

- |    | <u>Valve Type</u> | <u>Fail Position</u> |
|----|-------------------|----------------------|
| A. | Ball              | Open                 |
| B. | Ball              | Closed               |
| C. | Globe             | Open                 |
| D. | Globe             | Closed               |

ANSWER: D.

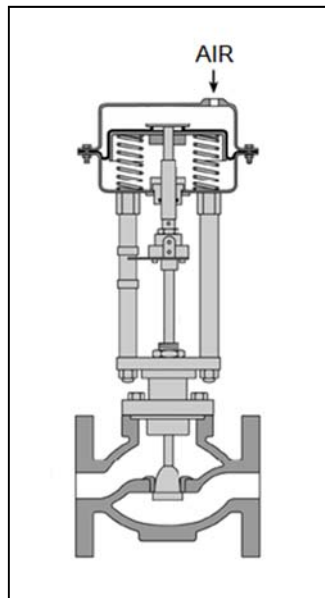

TOPIC: 291001  
KNOWLEDGE: K1.05 [2.9/2.8]  
QID: B203 (P2103)

Which one of the following is not a generally accepted method for locally verifying that a valve is open?

- A. Observe local flow rate instrumentation.
- B. Check the local valve position indicator indicates OPEN.
- C. Turn the valve operator in the close direction and verify that some movement occurs.
- D. Attempt to turn the valve operator in the open direction and verify that no movement occurs.

ANSWER: D.

TOPIC: 291001  
KNOWLEDGE: K1.05 [3.2/3.2]  
QID: B402 (P5)

To verify that a manual valve in an operating system is closed, the operator should observe valve position indication and operate the valve handwheel in the...

- A. open direction until flow sounds are heard, then close the valve using normal force.
- B. close direction using normal force and verify there is no substantial handwheel movement.
- C. close direction until it stops, then close it an additional one-half turn using additional force if necessary.
- D. open direction until the valve stem moves in the open direction, then close the valve using normal force.

ANSWER: B.

TOPIC: 291001  
KNOWLEDGE: K1.05 [2.9/2.8]  
QID: B503 (P205)

To verify the position of a fully open manual valve in an operating system, the operator should operate the valve handwheel...

- A. in the open direction until the valve is backseated one-half turn.
- B. to fully close the valve, then open the valve to the fully open position.
- C. in the closed direction, then open the valve to its previously open position.
- D. to open the valve until it touches the backseat, then close the valve to the desired position.

ANSWER: C.

TOPIC: 291001  
KNOWLEDGE: K1.05 [2.9/2.8]  
QID: B1404 (P1602)

Which one of the following is a generally accepted method for locally verifying that a manual valve is fully closed in a depressurized static piping system?

- A. Check a downstream flow gauge to be indicating zero flow.
- B. Visually observe the valve rising-stem threading to be fully exposed.
- C. Attempt to turn the valve handwheel in the close direction and verify no movement.
- D. Compare an upstream and downstream pressure gauge to ensure zero differential pressure.

ANSWER: C.

TOPIC: 291001  
KNOWLEDGE: K1.05 [3.2/3.2]  
QID: B1802 (P1704)

To verify a manual valve in an operating system is closed, the operator should observe valve position indication and operate the valve handwheel in the...

- A. open direction at least one full rotation, then close the valve using normal force.
- B. open direction until system flow is observed, then close the valve using normal force.
- C. close direction using normal force and verify there is no substantial handwheel movement.
- D. close direction using normal force, then operate the valve handwheel an additional one-quarter turn in the close direction.

ANSWER: C.

TOPIC: 291001  
KNOWLEDGE: K1.05 [2.9/2.8]  
QID: B2502 (P1602)

Which one of the following is a generally accepted method for locally verifying that a manual valve is fully closed in a depressurized piping system?

- A. Check a downstream flow gauge to be indicating zero flow.
- B. Compare an upstream and downstream pressure gauge to ensure zero differential pressure.
- C. Attempt to turn the valve handwheel in the close direction and verify no movement.
- D. Attempt to turn the valve handwheel in the open direction and verify movement.

ANSWER: C.

TOPIC: 291001  
KNOWLEDGE: K1.05 [2.9/2.8]  
QID: B7621 (P7621)

During a local inspection of a manually operated 12-inch gate valve, the valve stem is observed to extend outward from the valve handwheel by 1 inch. The entire external valve stem is threaded, except for a 1-inch section that becomes smooth just before the valve stem enters the packing gland.

Which one of the following describes the position of the gate valve?

- A. The valve is fully open or nearly fully open.
- B. The valve is fully closed or nearly fully closed.
- C. The valve may be in any position because it is a rising stem gate valve.
- D. The valve may be in any position because it is a non-rising stem gate valve.

ANSWER: B.

TOPIC: 291001  
KNOWLEDGE: K1.05 [2.9/2.8]  
QID: B7651 (P7651)

During a local inspection of a manually operated three-inch gate valve, the valve stem is observed to be flush with the top of the handwheel. Two inches of unthreaded valve stem is visible between the handwheel and the packing gland. The handwheel is mounted to the valve body and valve stem such that the handwheel can be rotated in either direction, but cannot change its axial position.

Which one of the following describes the position of the valve?

- A. The valve is fully open or nearly fully open.
- B. The valve is fully closed or nearly fully closed.
- C. The valve may be in any position because it has a rising stem.
- D. The valve may be in any position because it has a non-rising stem.

ANSWER: D.



TOPIC: 291001  
KNOWLEDGE: K1.06 [2.7/2.7]  
QID: B1003 (P1603)

An adjustment has just been completed on the packing gland of a motor-operated gate valve to stop a minor stem leak. Which one of the following can occur if the technician overtightened the packing gland?

- A. Decreased cooling flow to the valve internals.
- B. Separation of the valve disk from the valve stem.
- C. Misalignment of the valve position limit switches.
- D. Increased stroke time from fully open to fully closed.

ANSWER: D.

TOPIC: 291001  
KNOWLEDGE: K1.06 [2.7/2.7]  
QID: B2802 (P1303)

After an adjustment of the packing gland on a valve that had a minor packing leak, an operator attempts to operate the valve, but finds the valve is stuck. What is the most probable cause?

- A. The disk separated from the valve stem as a result of overtightening the packing gland.
- B. The operator placed the valve in the wrong position for adjusting the packing gland.
- C. The valve was overtorqued in the closed direction during the packing gland adjustment.
- D. The maintenance technician overtightened the packing gland, causing the stem to bind.

ANSWER: D.

TOPIC: 291001  
KNOWLEDGE: K1.06 [2.7/2.7]  
QID: B3503 (P3503)

Refer to the drawing of a water supply pump with two suction sources (see figure below). All motor-operated valves (MOVs) are currently closed.

Which one of the following MOV interlocks will permit the pump to take a suction on either the building sump or the water storage tank, while preventing the two sources from being cross-connected?

- A. Neither MOV-1 nor MOV-2 can be opened unless MOV-3 is fully closed.
- B. None of the MOVs can be opened unless at least one MOV remains fully closed.
- C. None of the MOVs can be opened unless at least two MOVs remain fully closed.
- D. Neither MOV-1 nor MOV-2 can be opened unless the other source MOV is fully closed.

ANSWER: D.

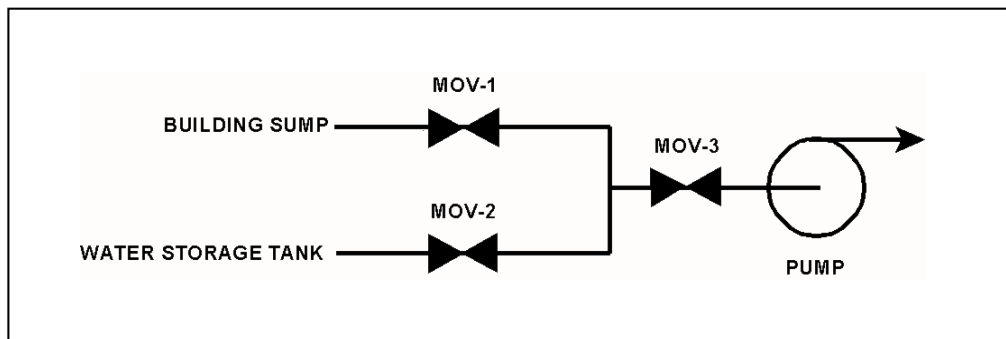

TOPIC: 291001  
KNOWLEDGE: K1.07 [3.4/3.4]  
QID: B1203

When transferring a valve controller from the manual mode to the automatic mode, the automatic valve controller output signal should be \_\_\_\_\_ the manual valve controller output signal at the time of transfer.

- A. equal to
- B. greater than
- C. less than
- D. increasing with

ANSWER: A.

TOPIC: 291001  
KNOWLEDGE: K1.07 [3.4/3.4]  
QID: B1502 (P220)

Prior to shifting a valve controller from automatic to manual control, why should the automatic and manual controller output signals be matched?

- A. To ensure the valve will operate in manual control upon demand.
- B. To ensure valve position indication is accurate in manual control.
- C. To move the valve to the new position prior to the transfer.
- D. To prevent a sudden valve repositioning during the transfer.

ANSWER: D.

TOPIC: 291001  
KNOWLEDGE: K1.07 [3.4/3.4]  
QID: B2204 (P802)

Two common types of check valves used in nuclear power plants are...

- A. globe and gate.
- B. ball and plug.
- C. swing and lift.
- D. needle and angle.

ANSWER: C.

TOPIC: 291001  
KNOWLEDGE: K1.08 [3.4/3.5]  
QID: B108 (P403)

When manually positioning a motor-operated valve, why must care be taken to avoid using excessive valve seating/backseating force?

- A. Limit switch settings may change.
- B. The valve may not operate on demand.
- C. The motor may not reengage.
- D. Torque switch settings may change.

ANSWER: B.

TOPIC: 291001  
KNOWLEDGE: K1.08 [3.4/3.5]  
QID: B204 (P204)

When the manual declutch lever of a motor-operated valve is moved out of the normal position, it \_\_\_\_\_ the motor and \_\_\_\_\_ the handwheel.

- A. engages; engages
- B. engages; disengages
- C. disengages; engages
- D. disengages; disengages

ANSWER: C.

TOPIC: 291001  
KNOWLEDGE: K1.08 [3.4/3.5]  
QID: B1605 (P1702)

A typical motor-operated valve with a declutch lever is installed in an emergency core cooling system (ECCS) application. The ECCS actuation signal is designed to energize the valve motor and open the valve. The valve is currently open, but being manually/locally closed by a technician as required by a surveillance test procedure. The declutch lever has been operated and released, and the valve is being closed by operation of the valve handwheel.

If an ECCS actuation signal is received, how will the valve be affected?

- A. The handwheel will disengage and the valve will automatically open.
- B. The handwheel will disengage and the valve will remain in the current position.
- C. The handwheel will remain engaged and the valve will automatically open.
- D. The handwheel will remain engaged and the technician can continue to close the valve.

ANSWER: A.

TOPIC: 291001  
KNOWLEDGE: K1.08 [3.4/3.5]  
QID: B2004 (P2003)

A surveillance test procedure is being performed on a typical motor-operated valve (MOV) with a declutch lever that is used in an emergency core cooling system (ECCS) application. The declutch lever has been operated and released, and the valve is being manually/locally opened by a technician. The MOV breaker is closed as required by the surveillance test procedure. During operation of the valve handwheel, an ECCS actuation signal is received that normally energizes the valve motor and closes the valve.

How will the valve be affected by the actuation signal?

- A. The handwheel will disengage and the valve will automatically close.
- B. The handwheel will disengage and the valve will remain in the current position.
- C. The handwheel will remain engaged and the valve will automatically close.
- D. The handwheel will remain engaged and the technician can continue to open the valve.

ANSWER: A.

TOPIC: 291001  
KNOWLEDGE: K1.08 [3.4/3.5]  
QID: B2603 (P2503)

When manually closing a motor-operated valve, why must the operator avoid using excessive valve seating force?

- A. The valve may bind and cause the motor to trip on overload during subsequent remote operation.
- B. The valve actuator clutch may be damaged and disable subsequent remote operation.
- C. The valve stem limit switches may be damaged and cause inaccurate remote valve position indication.
- D. The valve actuator position indicator may be damaged and cause inaccurate local valve position indication.

ANSWER: A.

TOPIC: 291001  
KNOWLEDGE: K1.08 [3.4/3.5]  
QID: B2704 (P2703)

A typical motor-operated valve (MOV) has just been opened from the main control room, and the breaker for the MOV has been opened. A plant operator has been directed to close the MOV locally for a surveillance test.

If the operator attempts to turn the MOV handwheel in the clockwise direction without first operating the declutch lever, which one of the following will occur?

- A. The handwheel will turn, but the valve stem will not move.
- B. The handwheel will not turn, and the valve stem will not move.
- C. The handwheel will turn, and the valve stem will move toward the closed position because the clutch is automatically engaged when the handwheel is turned.
- D. The handwheel will turn, and the valve stem will move toward the closed position because the clutch is automatically engaged when the breaker is opened.

ANSWER: A.

TOPIC: 291001  
KNOWLEDGE: K1.08 [3.4/3.5]  
QID: B4003 (P4002)

Which one of the following types of similarly sized valves requires the most manual valve stem rotation to move the valve from fully open to fully closed? (Assume that each valve has a non-rising stem.)

- A. Ball
- B. Gate
- C. Plug
- D. Butterfly

ANSWER: B.

TOPIC: 291001  
KNOWLEDGE: K1.09 [2.7/2.7]  
QID: B3304 (P3304)

A typical motor-operated valve has been returned to service following a complete maintenance overhaul of the valve and actuator. The valve was remotely opened and closed to verify operability. The measured valve stroke time in each direction was 15 seconds, which is 25 percent longer than normal.

Which one of the following could have caused the increased stroke time?

- A. The valve position limit switches were removed and were not reinstalled.
- B. The valve torque limit switches were misadjusted to open at half their normal setpoints.
- C. The valve was packed with improved packing material having a lower friction coefficient.
- D. The valve stem packing gland was overtightened after the packing material was replaced.

ANSWER: D.

TOPIC: 291001  
KNOWLEDGE: K1.09 [2.7/2.7]  
QID: B7631 (P7631)

A typical motor-operated valve has been returned to service following a complete maintenance overhaul of the valve and actuator. When the valve was remotely opened and closed to verify operability, the measured valve stroke time in each direction was 15 seconds, which is shorter than normal for this valve.

Which one of the following could have caused the shorter stroke time?

- A. The valve position limit switches were removed and were not reinstalled.
- B. The valve torque limit switches were misadjusted to open at twice their normal setpoints.
- C. The valve was packed with improved packing material having a lower friction coefficient.
- D. The valve stem packing gland was overtightened after the packing material was replaced.

ANSWER: C.



TOPIC: 291001  
KNOWLEDGE: K1.10 [3.1/3.1]  
QID: B205 (P1503)

Check valves are normally used to prevent...

- A. overpressurization of nonoperating system piping and components.
- B. backflow through nonoperating components or flowpaths.
- C. pump runout by providing a constant backpressure.
- D. pump cavitation by keeping nonoperating systems filled.

ANSWER: B.

TOPIC: 291001  
KNOWLEDGE: K1.10 [3.1/3.1]  
QID: B302 (P303)

A stop check valve is a type of check valve that...

- A. cannot be shut remotely.
- B. can be used to prevent flow in both directions.
- C. contains both a gate valve disk and a check valve disk.
- D. can be opened manually to allow flow in both directions.

ANSWER: B.

TOPIC: 291001  
KNOWLEDGE: K1.10 [3.1/3.1]  
QID: B1102 (P2202)

Which one of the following is the type of valve used to control the direction of fluid flow through a system and prevent backflow?

- A. Butterfly valve
- B. Gate valve
- C. Globe valve
- D. Check valve

ANSWER: D.

TOPIC: 291001  
KNOWLEDGE: K1.10 [3.1/3.1]  
QID: B2903 (P1003)

A typical check valve is designed to...

- A. permit flow in only one direction.
- B. prevent system overpressure.
- C. isolate system components.
- D. perform automatic pump venting.

ANSWER: A.

TOPIC: 291001  
KNOWLEDGE: K1.11 [3.2/3.2]  
QID: B6 (P1902)

Which one of the following describes the function and use of the backseat on a manual valve?

- A. Removes pressure from the packing/stuffing box and is typically used to isolate the stuffing box for valve repacking.
- B. Removes pressure from the packing/stuffing box and is typically used when needed to isolate packing leakage.
- C. Acts as a backup in case the primary seat leaks and is typically used during system isolation for personnel protection.
- D. Acts as a backup in case the primary seat leaks and is typically used when needed to prevent the primary seat from leaking excessively.

ANSWER: B.

TOPIC: 291001  
KNOWLEDGE: K1.11 [3.2/3.2]  
QID: B206 (P201)

An operator attempts to close a fully-open upright manual gate valve to isolate a pump in a cooling water system that has been cooled down for maintenance. However, the operator is unable to rotate the handwheel in the close direction.

Which one of the following could cause this condition?

- A. A hydraulic lock has developed under the valve disk.
- B. A hydraulic lock has developed in the valve bonnet between the valve disk and the packing gland.
- C. The two halves of the valve disk have expanded and are jammed against the valve seats.
- D. The valve disk has jammed against its backseat by the difference in the thermal contraction of the stem and the bonnet.

ANSWER: D.

TOPIC: 291001  
KNOWLEDGE: K1.11 [3.2/3.2]  
QID: B1705 (P1405)

Refer to the drawing of a valve (see figure below).

Which one of the following describes the type of valve shown?

- A. Rising-stem globe valve
- B. Nonrising-stem globe valve
- C. Rising-stem gate valve
- D. Nonrising-stem gate valve

ANSWER: D.

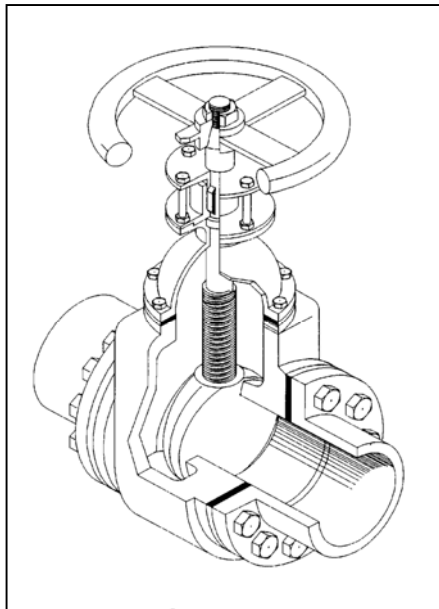

TOPIC: 291001  
KNOWLEDGE: K1.11 [3.2/3.2]  
QID: B2504 (P2504)

In a comparison between butterfly valves and ball valves, \_\_\_\_\_ valves are generally more leak-tight in high pressure applications; and \_\_\_\_\_ valves generally exhibit the smaller pressure decrease when fully open.

- A. ball; ball
- B. ball; butterfly
- C. butterfly; ball
- D. butterfly; butterfly

ANSWER: A.

TOPIC: 291001  
KNOWLEDGE: K1.11 [3.2/3.2]  
QID: B2904 (P2903)

In a comparison between ball valves and butterfly valves in the same water system application, the valve that typically would allow more leakage when fully closed with a high differential pressure is the \_\_\_\_\_ valve; and the valve that typically would cause the greater pressure loss when fully open is the \_\_\_\_\_ valve.

- A. ball; butterfly
- B. ball; ball
- C. butterfly; butterfly
- D. butterfly; ball

ANSWER: C.

TOPIC: 291001  
KNOWLEDGE: K1.11 [3.2/3.2]  
QID: B3804 (P3804)

In a comparison between ball valves and butterfly valves in the same water system application, the valve that would typically be more leak-tight when fully closed with a high differential pressure is the \_\_\_\_\_ valve; and the valve that typically results in the greater pressure decrease when fully open is the \_\_\_\_\_ valve.

- A. ball; butterfly
- B. ball; ball
- C. butterfly; butterfly
- D. butterfly; ball

ANSWER: A.

TOPIC: 291001  
KNOWLEDGE: K1.11 [3.2/3.2]  
QID: B7003 (P7002)

In a comparison between ball valves and butterfly valves in the same cooling water system application, the valve that would typically experience the greater seat leakage when fully closed with a large differential pressure is the \_\_\_\_\_ valve; and the valve that would typically cause the smaller head loss when fully open is the \_\_\_\_\_ valve.

- A. ball; butterfly
- B. ball; ball
- C. butterfly; butterfly
- D. butterfly; ball

ANSWER: D.

TOPIC: 291001  
KNOWLEDGE: K1.12 [2.6/2.8]  
QID: B16

Which one of the following valves is most likely to be used in a throttling application?

- A. Stop valve
- B. Globe valve
- C. Gate valve
- D. Butterfly valve

ANSWER: B.

TOPIC: 291001  
KNOWLEDGE: K1.12 [2.6/2.8]  
QID: B110

Some valve positioning (drive) devices are capable of stopping the valve between a fully open and a fully closed (throttled) position. Which one of the following valves has the best throttling characteristics?

- A. Stop valve
- B. Globe valve
- C. Gate valve
- D. Butterfly valve

ANSWER: B.

TOPIC: 291001  
KNOWLEDGE: K1.12 [2.6/2.8]  
QID: B172

Globe valves are preferred over gate valves for throttling because...

- A. flow control is more linear for globe valves than for gate valves.
- B. head loss from a fully open globe valve is smaller than the head loss from a fully open gate valve.
- C. valve position indication for a midpositioned valve is more reliable for globe valves than for gate valves.
- D. valve motor operators are more adaptable to globe valves than to gate valves.

ANSWER: A.

TOPIC: 291001  
KNOWLEDGE: K1.12 [2.6/2.8]  
QID: B406

Gate valves are most often used to...

- A. protect system integrity by relieving excess pressure.
- B. redirect fluid flow in an operating system.
- C. isolate fluid flow in an operating system.
- D. control fluid flow rate in an operating system.

ANSWER: C.



TOPIC: 291001  
KNOWLEDGE: K1.12 [2.6/2.8]  
QID: B504 (P1104)

Gate valves should not be used to throttle fluid flow because...

- A. the tortuous flow path through a gate valve body makes flow control difficult.
- B. gate valves must be fully opened and backseated to prevent stem leakage.
- C. the turbulent flow created by a partially opened gate valve will cause erosion damage to the valve seat.
- D. the large size of the gate valve disk requires an oversized actuator to accurately position the disk.

ANSWER: C.

TOPIC: 291001  
KNOWLEDGE: K1.12 [2.6/2.8]  
QID: B805 (P2604)

A gate valve is generally a poor choice for throttling fluid flow because...

- A. the turbulent flow created by a partially opened gate valve can cause extensive damage to the valve.
- B. the tortuous path through a gate valve body can make flow control difficult.
- C. excessive stem leakage will result unless the gate valve is fully open or fully closed.
- D. the head loss from a throttled gate valve will result in an unacceptable reduction in system flow rate.

ANSWER: A.

TOPIC: 291001  
KNOWLEDGE: K1.12 [2.6/2.8]  
QID: B905 (P2404)

In a comparison between gate valves and globe valves in the same water system application, gate valves...

- A. are more effective at throttling flow.
- B. are more effective as pressure regulating valves.
- C. produce a larger pressure decrease when fully open.
- D. require more force to open against large differential pressures.

ANSWER: D.

TOPIC: 291001  
KNOWLEDGE: K1.12 [2.6/2.8]  
QID: B1205 (P2004)

After an adjustment of the packing gland on a valve that had a minor packing leak, the operator attempts to operate the valve, but finds that the valve is stuck. What is the most probable cause?

- A. The disk separated from the valve stem as a result of overtightening the packing gland.
- B. The operator placed the valve in the wrong position for adjusting the packing gland.
- C. The valve was overtorqued in the close direction during the packing gland adjustment.
- D. The maintenance technician overtightened the packing gland, causing the stem to bind.

ANSWER: D.

TOPIC: 291001  
KNOWLEDGE: K1.12 [2.6/2.8]  
QID: B1305 (P1901)

Which one of the following is a disadvantage associated with using a gate valve, versus a globe valve, to throttle flow in a cooling water system?

- A. The tortuous flow path through a throttled gate valve body makes flow control difficult.
- B. A gate valve will experience stem leakage unless it is fully opened and backseated.
- C. The turbulent flow created by a throttled gate valve will cause erosion damage to the valve seat.
- D. A fully open gate valve will produce a greater system head loss than a fully open globe valve.

ANSWER: C.

TOPIC: 291001  
KNOWLEDGE: K1.12 [2.6/2.8]  
QID: B1505 (P1302)

Consider a 3-inch gate valve and a 3-inch globe valve in separate but identical operating water systems. If both valves are fully open, the gate valve will produce the \_\_\_\_\_ head loss and the \_\_\_\_\_ flow rate.

- A. smaller; larger
- B. larger; smaller
- C. smaller; smaller
- D. larger; larger

ANSWER: A.

TOPIC: 291001  
KNOWLEDGE: K1.12 [2.6/2.8]  
QID: B1604 (P1604)

In a comparison between a typical gate valve and a typical globe valve in the same water system application with both valves fully open, the gate valve has a \_\_\_\_\_ pressure drop and is normally used in \_\_\_\_\_ flow applications.

- A. larger; throttling
- B. larger; on/off
- C. smaller; throttling
- D. smaller; on/off

ANSWER: D.

TOPIC: 291001  
KNOWLEDGE: K1.12 [2.6/2.8]  
QID: B1805 (P1501)

Consider a 3-inch gate valve and a 3-inch globe valve in the same flowing water system application. If both valves are fully open, the globe valve produces the \_\_\_\_\_ head loss and the \_\_\_\_\_ flow rate.

- A. larger; larger
- B. larger; smaller
- C. smaller; larger
- D. smaller; smaller

ANSWER: B.

TOPIC: 291001  
KNOWLEDGE: K1.12 [2.6/2.8]  
QID: B2005 (P602)

In a comparison between a globe valve and a gate valve in the same water system application, the gate valve has a \_\_\_\_\_ pressure drop when fully open and is the \_\_\_\_\_ choice for throttling.

- A. higher; better
- B. lower; better
- C. higher; poorer
- D. lower; poorer

ANSWER: D.

TOPIC: 291001  
KNOWLEDGE: K1.12 [2.6/2.8]  
QID: B2305 (P2304)

In a comparison between globe valves and gate valves in the same water system application, globe valves...

- A. are less effective at throttling flow.
- B. are less effective as pressure regulating valves.
- C. produce a smaller pressure decrease when fully open.
- D. require less force to open against large differential pressures.

ANSWER: D.

TOPIC: 291001

KNOWLEDGE: K1.12 [2.6/2.8]

QID: B2605 (P2204)

Why are gate valves generally not used to throttle water flow?

- A. Rapid changes in flow direction inside the valve cause a large unrecoverable system head loss.
- B. Gate valves experience stem leakage unless they are fully open or fully closed.
- C. The turbulent flow created by a partially opened gate valve causes excessive seat and disk wear.
- D. Flow rate through a gate valve is not proportional to the differential pressure across the valve.

ANSWER: C.