

**Response to NRC Review Comments  
Transmitted by Letter Dated June 22, 2001,  
to the Nuclear Energy Institute Relating to**

***PWR Materials Reliability Program  
Interim Alloy 600 Safety Assessment for US PWR Plants (MRP-44)  
Part 2: Reactor Vessel Top Head Penetrations  
EPRI TP-1001491, Part 2, May 2001***

**MRP 2001-050NP**

**June 29, 2001**

**Prepared by:  
PWR Materials Reliability Program Alloy 600 Issues Task Group**

**NON-PROPRIETARY INFORMATION**

Notice: This report contains the non-proprietary information that is included in the proprietary version of this report. The proprietary version of this report contains proprietary information that is the intellectual property of PWRMRP utility members and EPRI. Accordingly, the proprietary reports are available only under license from EPRI and may not be reproduced or disclosed, wholly or in part, by any Licensee to any other person or organization.

## **Response to NRC Review Comments Relating to**

### ***PWR Materials Reliability Program Interim Alloy 600 Safety Assessment for US PWR Plants (MRP-44) Part 2: Reactor Vessel Top Head Penetrations EPRI TP-1001491, Part 2, May 2001***

#### **Introduction**

The USNRC staff has reviewed TP-1001491, Part 2, "PWR Materials Reliability Program Interim Alloy 600 Safety Assessments for US PWR Plants (MRP-44), Part 2: Reactor Vessel Top Head Penetrations," and has developed a number of comments. Preliminary comments were transmitted to the MRP on May 25, 2001, revised comments were submitted on May 29, and final comments were provided in a letter dated June 25. The final set of comments includes three supplementary questions regarding relevant inspection capabilities.

The staff's initial comments were discussed, and results provided, during a meeting at the USNRC offices on June 7, 2001. Further information regarding inspection results and inspection plans was provided during the MRP Alloy 600 Issue Task Group Industry Workshop in Atlanta, Georgia on June 13 and 14.

This document provides an integrated response to the USNRC staff comments including a summary of the MRP response in each of the topical areas followed by detailed discussion of each comment in the order presented by the NRC.

#### **Summary**

USNRC staff comments on the interim safety assessment for Alloy 600 RPV top head penetrations addressed six main topics. The following is an overview of the MRP response to each of these topics.

1. Section 3.0: RPV Closure Head Penetration Configurations, Fits and Leakage Detectability  
This section addresses the six NRC comments related to the ability of visual inspections of the reactor vessel head to find leaks. The focus of the comments was on the ability of visual inspections to detect leaks given the specified initial interference fits, the potential for plugging of the annulus by boric acid deposits or corrosion, and the effects of nozzle ovalization and flange rotation.

The response shows that leakage should be detectable by visual means for most plants which perform inspections that provide a good view of the location where the nozzles penetrate the vessel head surface. Leaks have been detectable by visual means in fifteen nozzles including three nozzles with up to 0.0014 inch initial interference fit as determined by as-built dimensions. These nozzles have included locations near the center of the vessel

head as well as in peripheral locations where ovalization and the effects of flange rotation are greatest. Although it is suspected that some of the leaking penetrations had been leaking for several years, the leakage paths did not plug up and leakage detection was proven effective once the top surface of the head had been cleaned of boric acid crystal accumulations from other leakage sources and the inspectors were aware of the small amounts of boric acid crystals that are to be expected.

The specified maximum interference fit for all but five domestic PWR plants is 0.003 inches. As-built dimensional measurements show that the tightest initial fit for any of the Oconee and ANO-1 nozzles found to have leakage and through-wall flaws was 0.0014 inches.

Four of the five plants with a specified maximum 0.003 inch interference fit have relatively low vessel head temperatures and are expected to have a lower risk of PWSCC and leakage than the plants that have had CRDM nozzle leakage.

Analyses show that the initial interference fit is reduced by about 0.0023 inch for a typical 4-inch diameter CRDM nozzle under operating temperature and pressure conditions. The reduction is primarily the result of pressure expansion of the vessel head offset by a small increase in tightness due to differential thermal expansion between the nozzle and head material. The initial interference fit is expected to be further reduced under transient conditions where the Alloy 600 nozzles are at a lower temperature than the average vessel head temperature, such as during plant cool down prior to a refueling outage.

Seven plants performed 100% visual inspections of the top surface of the vessel head during Spring 2001 outages and photographs showing the conditions encountered for six of the seven are attached. As shown in the photographs these plants used a variety of methods to provide access for the inspections depending upon plant preferences and the head insulation design. Other than the Oconee units and ANO-1, no plants reported leaks.

2. Section 4.0: Time-at-Temperature Comparisons and Plant Inspection Status

This section addresses the six NRC questions related to the relative ranking of plants from the standpoint of RPV nozzle PWSCC. The focus of these comments was on providing the data used for individual plant predictions, the effect of activation energy on predictions, benchmarking relative to foreign plants, the basis for selecting 10 EFPYs as a cutoff for initial attention, the effect of crack growth rates on the 10 year cutoff, and the potential use of measures to detect leakage online.

Data have been provided regarding design parameters, operating time/temperature, and previous inspection results for plants that have scheduled refueling outages in the Fall of 2001 and meet the 10 year criterion. Data for other plants is currently being confirmed prior to submittal to the NRC staff.

The 10 year criterion relative to Oconee 3 was established by engineering judgment to provide margin for uncertainties in assessment methodology and plant-specific input data such as the actual vessel head temperature.

Brief descriptions are provided of three methods that have the potential of detecting leak rates lower than the sensitivity of the on-line methods currently in use. These methods could provide advance warning of a significant circumferential crack and will be evaluated by the MRP.

3. Section 5.0: Structural Margin for Circumferential Cracks Above J-Groove Weld

This section addresses the three NRC questions related to the growth rate of circumferential cracks above the J-groove weld. The focus of these questions was on the time for a crack to grow to the critical size, the effect of contaminants on crack growth rate and details of stress analyses that show that stress levels decrease as the circumferential crack grows around the nozzle.

Calculations using two different methods show that it would have taken at least 4-5 years from the time of repair for the circumferential cracks above the J-groove weld in Oconee 3 to propagate to the size required to support three times the design pressure. Fracture mechanics calculations are currently in progress to evaluate the potential for the cracks to arrest when the crack reaches the size where the welding residual stresses are largely relieved.

Initial reviews of fabrication records at Combustion Engineering and Babcock & Wilcox show that the nozzles and holes in the vessel shell were cleaned before assembly to avoid contaminants.

4. Risk Informed Review

This section addresses the two NRC questions related to risk assessment. The first is related to the probability, consequences and compensatory measures for a potential CRDM LOCA, and the second is related to the accident progression following a CRDM nozzle ejection.

Calculations are being performed to assess the probability of having undetected circumferential flaws, of a nozzle rupture, and of a CRDM ejection following a postulated rupture. The probabilities are being determined based on results of vessel top head and under the head inspections carried out to date, and on probabilistic fracture mechanics calculations taking into account the reduction in stresses and crack tip stress intensity as circumferential cracks grow around the nozzle and relieve welding residual stresses. The calculations will be included in the final safety assessment report.

A description of a hypothetical CRDM ejection is provided. Work is in progress to evaluate the potential impact on adjacent CRDMs caused by the ejected CRDM or by the water escaping through the head.

5. Loose Parts Assessment

The NRC requested information regarding the potential for, and consequences of, loose parts generated as a result of linking up of circumferential and axial cracks below the J-groove weld.

Evaluations provided by Framatome ANP and Westinghouse show that the risk of loose parts being generated is small, and the consequences have already been considered in the plant design basis.

6. Inspection Capabilities

This section addresses the three NRC questions related to inspection capabilities. The focus of these questions was on the capabilities of the current inspection methods, the number of inspections that can be performed during the Fall 2001 refueling outages and the time and cost impacts of visual and volumetric inspections.

At present, volumetric inspection capabilities (inspection equipment and calibration blocks) have been optimized for inside surface initiated PWSCC as was found starting in 1991. UT equipment that was previously developed for characterizing cracks on the nozzle inside surfaces also has the potential for finding cracks initiating from the outside surface of the nozzle. However, the potential effects of shallow inside surface cracks on the ability to detect outside surface cracks is not known. Qualification specimens have not been fabricated for these defects. PT methods can be used to examine the surface of the welds and the outside surface of the nozzle below the welds. However, it is likely that PT examination of the welds will result in false calls due to small, and insignificant, weld defects. The MRP will provide guidance to plants regarding UT and PT inspection techniques, limitations, acceptance criteria and methods to resolve findings.

## **MRP Recommendations**

The MRP has recommended the following:

- All plants should continue with regularly scheduled inspections of the top of the vessel head for boric acid deposits in accordance with licensee commitments made in response to Generic Letter 88-05. These inspections should be based on insights gained from head penetration inspections performed at Oconee and ANO-1 such as the potential impact of boric acid deposits from unrelated leakage. The MRP is developing guidance for the Fall 2001 refueling outages.
- Plants that are within 10 effective full power years (EFPYs) of Oconee 3 based on effective time at temperature and having Fall 2001 refueling outages should perform a visual inspection of the reactor vessel top head capable of detecting small amounts of leakage similar to that observed at Oconee and ANO-1. This recommendation applies regardless of previous inspection history.

Upon completion of the Fall 2001 refueling outages, the MRP will assess the results to determine whether further recommendations are necessary. The MRP will continue to assess and develop inspection recommendations and technology in this area.

### **Section 3.0 Comment 1**

*"Appropriate consideration of the interference fit incorporated into the initial fabrication of the vessel head penetrations (VHPs) is important in evaluating the ability of visual leakage detection methods (e.g., boric acid walkdowns) to accurately identify through-wall degradation at the subject locations. While the recent instances of cracking in several VHPs at ANO-1 and Oconee Units 2 and 3 indicate that it is possible to detect through-wall flaws caused by primary water stress corrosion (PWSCC) based on boric acid walkdowns that can look under the insulation, the information provided in Section 3 of the MRP-44, Part 2 report does not support the conclusion that these events were "bounding" (i.e., that, for a similar size through-wall flaw at some other facility, an equivalent or greater amount of leakage would be expected)."*

It was reported to the NRC on June 7 that leakage should be detectable for most reactor head penetrations given significant cracking similar to the type discovered at Oconee and ANO-1.

The expectation is that leakage should be detectable for most reactor head penetrations given significant cracking of the type discovered at Oconee and ANO-1 and a careful visual inspection of the locations where the nozzles penetrate the vessel head surface. The main factors in support of this position are as follows:

- Leakage was detected from fifteen nozzles at four units by visual inspection of the vessel top head surface.
- Experience at Oconee 2 showed that three nozzles with up to a 0.0014 inch initial diametral interference fit exhibited detectable leakage (see supporting details under Section 3.0 Comment 2).
- As shown in Figure 1, Oconee and ANO-1 experience demonstrates that leakage can be detected from nozzles adjacent to the central nozzle and in peripheral locations. This provides confidence that leakage can be detected regardless of location on the head.
- No significant cracking was found in 27 additional "non-leaking" Oconee 1 and Oconee 3 CRDM nozzles. Therefore, there are no known cases involving CRDM nozzles with through-wall cracks where leakage was not detected.
- The leakage at Oconee and ANO-1 was detectable through visual observation of small quantities of boric acid crystal accumulation. Small quantities of boric acid are typical from many PWSCC leaks, even for cases where the nozzles are installed with clearance fits.
- The specified maximum interference fit for all but five domestic PWR plants is 0.003 inches. As-built dimensional measurements show that the tightest initial fit for any of the

Oconee and ANO-1 nozzles found to have leakage and through-wall flaws was 0.0014 inches.

- Four of the five plants with specified initial maximum interference greater than 0.003 inches are in plants with relatively low vessel head temperatures. These plants are predicted to be outside ten effective full power years (EFPYs) of the Oconee units based on time at temperature and are therefore considered to be less susceptible to PWSCC.
- Calculations described in the response to Section 3.0 Comment 4 show that the initial interference fit for typical CRDM nozzles is expected to decrease by about 0.0023 inches under operating temperature and pressure conditions. For all but the five plants noted in the previous two paragraphs, the resultant operating interference would be less than 0.001 inches. The small initial interference fit is expected to be further reduced under transient conditions where the Alloy 600 nozzles are at a lower temperature than the average vessel head temperature, such as during plant cool down prior to a refueling outage.
- Confirmation of the difficulty of producing a seal with this type of application is provided by two examples where some roll expanded Alloy 600 penetrations have leaked despite the roll expansion.
  - As shown in Figure 2, Alloy 600 pressurizer instrument nozzles in EDF plants were roll expanded into the vessel shell prior to making the J-groove weld. Leaks were discovered from nozzles in two plants (Nogent 1 and Cattenom 2) after one operating cycle. The roll expansions did not prevent leakage in these nozzles.
  - In one BWR plant, leaking Alloy 600 CRDM nozzles were roll expanded into the vessel bottom head over several inches to stop leaks. Some of these roll expanded nozzles subsequently developed leaks.

In summary, while the Oconee and ANO-1 experience is not bounding in all cases, the evidence shows that leakage is expected from most RPV head nozzles with significant PWSCC that results in a leak path to the annulus above the J-groove weld. Specifically, leakage has been demonstrated from 15 nozzles with up to 0.0014 inches of initial interference, the maximum specified interference for all but five plants is 0.003 inches, the initial interference fit for a typical CRDM nozzle is expected to decrease by about 0.0023 inches under normal operating pressure and temperature conditions and even more under some transient conditions, and there have been several cases involving Alloy 600 nozzles that leaked despite having been roll expanded into the pressure boundary.



Nozzle 56 Leaked at  
ANO-1 and Ocone 3  
Circ Crack Above J-  
Groove Weld at Ocone 3  
Only

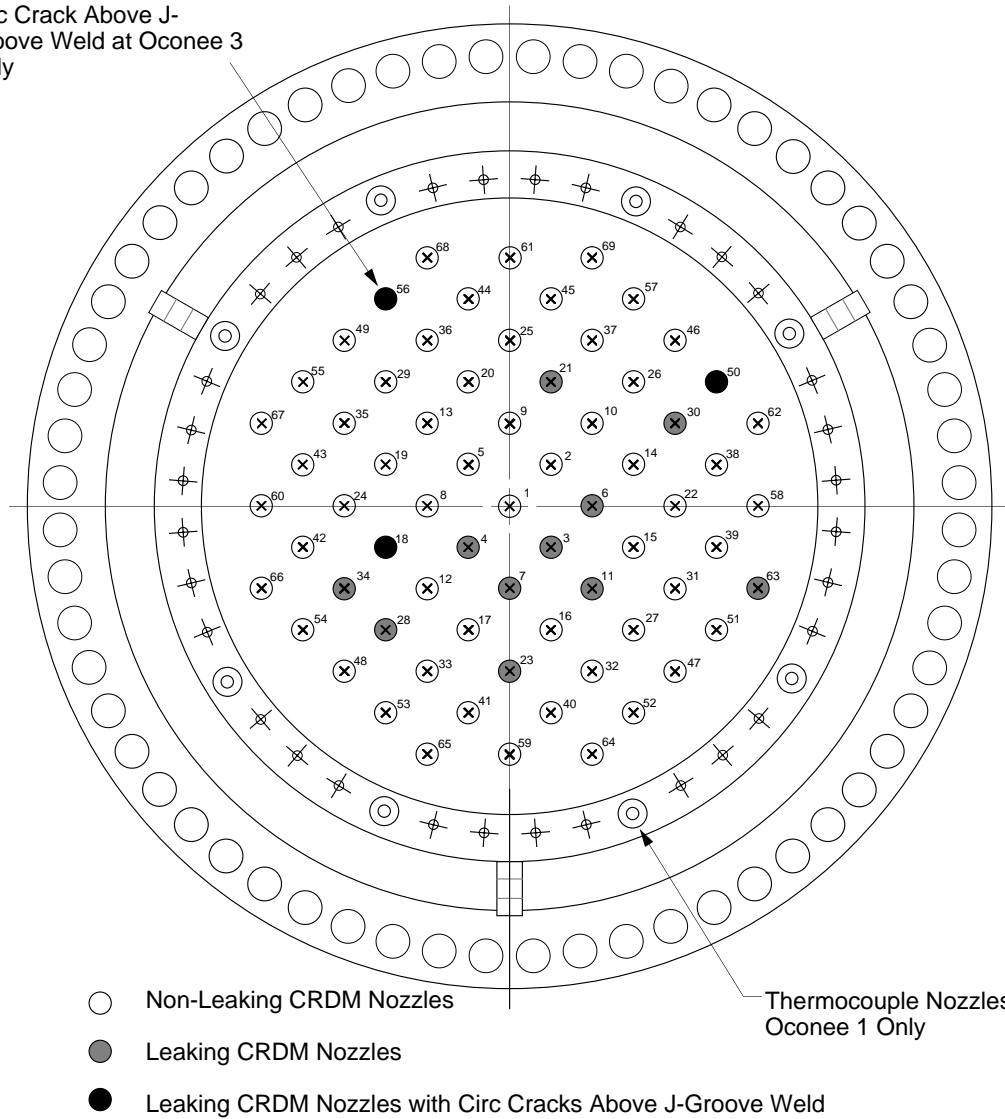

Figure 1  
Locations of Leaking CRDM Nozzles at Ocone and ANO-1

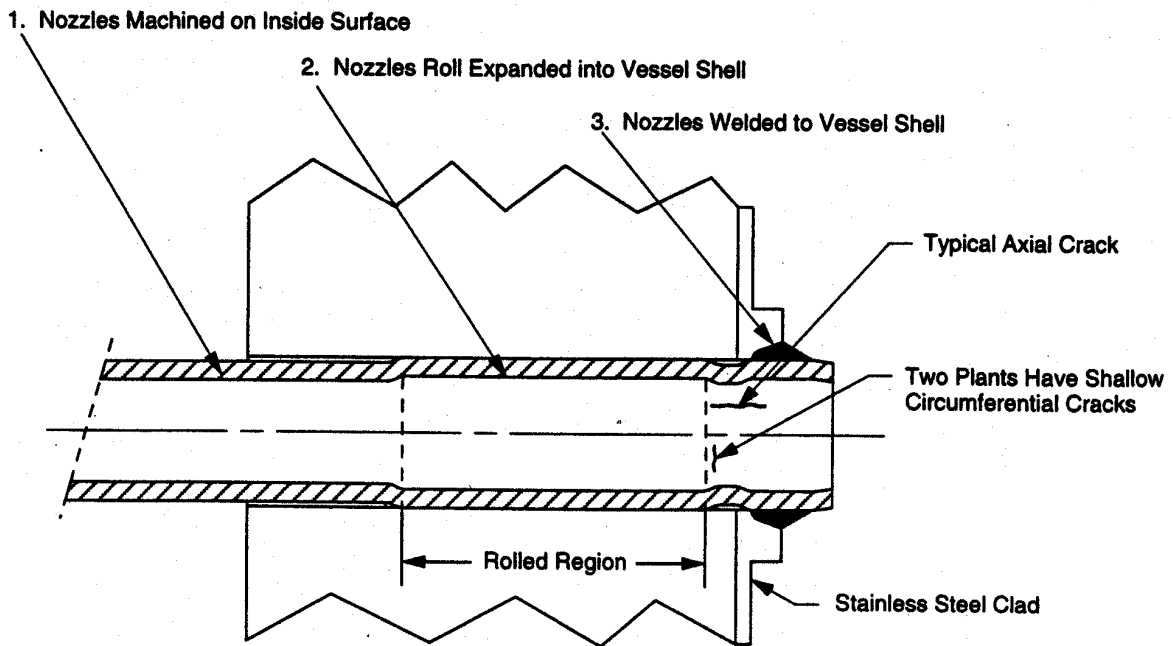

Figure 2  
Rolled and Welded Pressurizer Instrument Nozzle in EDF Plants

**Section 3.0 Comment 2**

*"In order to better understand the leakage potential of PWSCC at VHP locations, and to assist in understanding how comparisons can be made to the leakage potential for VHPs at other facilities, the staff request additional information detailing the precise interference fits (as opposed to a range of values) for the VHPs which leaked at ANO-1 and Oconee."*

Fabrication drawings for the Oconee and ANO-1 reactor vessel heads manufactured by Babcock and Wilcox specify that the nozzle outside diameter should be ground to produce a 0.0005 – 0.0015 inch diametral interference fit into the hole in the vessel head. Measurements were taken during fabrication of the hole diameters in the head at the top and bottom of the interference fit region and of the nozzle outside diameters prior to installation of the nozzles. This information was used to calculate the actual fit at the top and bottom of the interference fit region for these plants.

Figure 3 shows the range of fits for the leaking CRDM nozzles at Oconee and ANO-1. The information provided during the June 7 meeting for Oconee 1, Oconee 3 and ANO-1 has been supplemented with data for the four leaking nozzles at Oconee 2. The three nozzles found to have circumferential cracks above the J-groove weld are appended with "(C)" in the figure.

The data in Figure 3 show that one nozzle had a clearance fit rather than the specified small interference fit. The remaining nozzles had at least one end of the interference fit region within the specified tolerance. It should be noted that three of the four leaking nozzles at Oconee 2 had interference fits of 0.0014 inches at one end and at least 0.0011 inches at the other end. In summary, leaks have been confirmed from fourteen nozzles with confirmed initial interference fits, including three nozzles with at least 0.0014 inches of assembly interference.

Framatome ANP and Westinghouse are currently collecting and evaluating available information showing as-built dimensions for hole diameters and nozzle outside diameters for other vessels in order to support the industry's response to this issue.

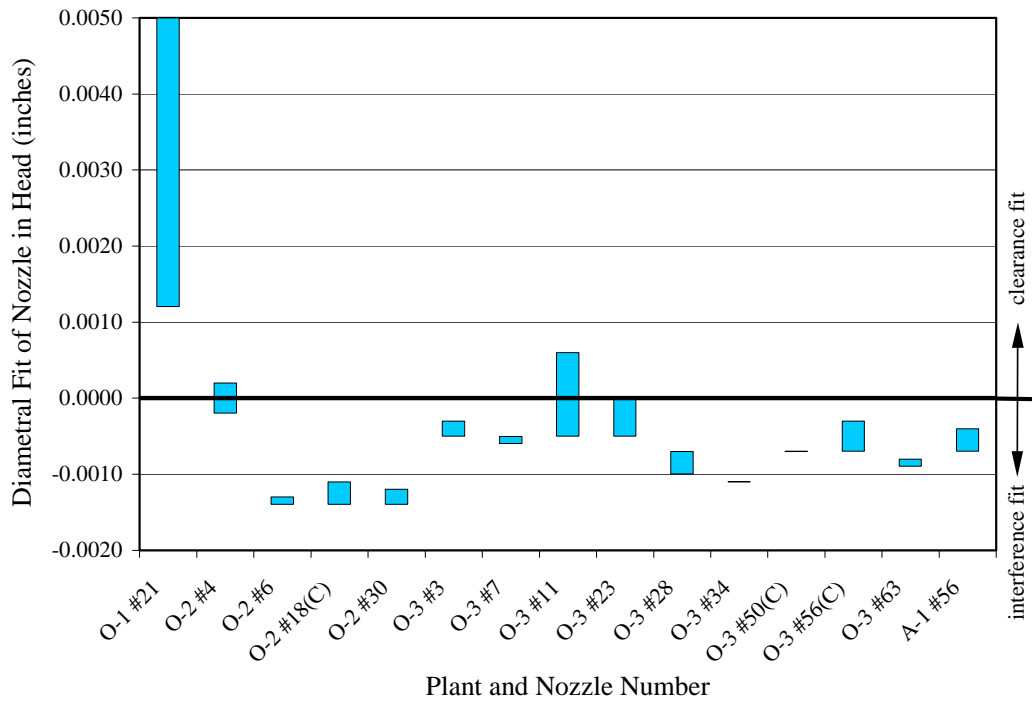

Figure 3  
Actual Interference Fits of Leaking CRDM Nozzles at Oconee 1, 2 and 3 and ANO-1

**Section 3.0 Comment 3:**

*"The staff notes that, based on information in ASME Code Section II, Part D, the coefficient of thermal expansion for Alloy 600 is slightly greater than that for low alloy vessel steels throughout the temperature range of interest (70 °F to 600 °F). This would lead to the conclusion that the magnitude of the interference fit would grow as the vessel was heated up from room temperature to operating temperature. Further, internal pressurization of the VHP nozzle may be expected to further expand the nozzle into the vessel head penetration. Other potential effects related to RPV head distortion at pressure, flange rotation, and/or vessel head penetration ovalization are not discussed in Section 3.0. Address how these factors may affect central and peripheral VHPs differently. Provide additional information to support your statement that "...analyses show that the initial fit tends to open up at operating temperature and pressure." Provide details on the finite element analysis (FEA) of the RPV head used to support this statement, including modeling assumptions, boundary conditions and results."*

**Effect of Temperature on Nozzle Fit**

The hole diameter in the vessel head and outside diameter of the nozzle both increase with temperature. The change in the diameter of each part is a function of the coefficient of thermal expansion ( $\alpha$ ), the initial diameter of the part ( $D$ ), and the change between room temperature and operating temperature ( $\Delta T$ ) as given by the equation:

$$\Delta D_{thermal} = \alpha D \Delta T$$

The current edition of Section II of the ASME Boiler and Pressure Vessel Code specifies the same mean coefficient of thermal expansion of  $7.8 \times 10^{-6}$  in/in/°F from room temperature (70°F) to typical reactor vessel head operating temperature ( $\approx 600^\circ\text{F}$ ) for Alloy 600 nozzle material and typical low-alloy steel reactor vessel head material. Since the head and nozzle operate at essentially the same temperature, no change in fit is predicted with temperature changes using the current ASME Code coefficients of thermal expansion.

Earlier versions of the ASME Boiler and Pressure Vessel Code reported the mean coefficients of thermal expansion from room temperature to 600°F to be  $7.23 \times 10^{-6}$  in/in/°F for low-alloy steel and  $7.90 \times 10^{-6}$  in/in/°F for Alloy 600. These values result in the nozzle expanding more than the vessel shell thereby resulting in the interference increasing by 0.0014 inches for the case of a typical 4-inch diameter CRDM nozzle.

Data from other sources suggest that the mean coefficient of thermal expansion from room temperature to 600°F for the low-alloy steel material is close to the previously specified value of  $7.23 \times 10^{-6}$  in/in/°F, and that of the Alloy 600 material is the same as the current  $7.8 \times 10^{-6}$  in/in/°F. These data result in the interference increasing by 0.0012 inch on a 4-inch diameter nozzle when going from 70°F to 600°F.

### Effect of Pressure on Nozzle Fit

As with temperature, the penetration bore in the vessel head and outside diameter of the nozzle both increase when internal pressure is applied.

Alloy 600 nozzles can be modeled as capped thick wall cylinders under internal pressure loading. For the case of a typical CRDM nozzle with 4.00 inch outside diameter, 2.75 inch inside diameter, 2250 psi internal pressure, and a modulus of elasticity of  $28.7 \times 10^6$  psi at 600°F, the diametral expansion of the nozzle is:

$$\Delta D_{nozzle.pressure} = 0.00048''$$

The low-alloy steel vessel head is a sphere with a hole for the nozzle. For the typical case of 172 inch inside diameter, 7 inch wall thickness, 2250 psi internal pressure, a modulus of elasticity of  $26.4 \times 10^6$  psi at 600°F, and a stress concentration factor of 2 for a hole subjected to biaxial stresses, the diametral expansion is:

$$\Delta D_{hole.pressure} = 0.00402''$$

This approach conservatively ignores the effect of adjacent holes in reducing the effective modulus of elasticity of the head. Some peripheral nozzles are located such that there are no adjacent nozzles on three sides as shown in the head arrangement drawings in Appendix A of MRP-44, Part 2.

This analysis shows that the holes in the vessel head open up considerably more than the nozzles due to internal pressure effects such that the initial interference fit in typical 4-inch CRDM nozzles decreases by about 0.0035 inches on the diameter due to pressure effects.

### Combined Temperature and Pressure Effects

Combining the above results for a typical 4-inch CRDM nozzle shows that the initial interference fit decreases by about 0.0023 inches due to operating pressure and temperature conditions. The trend is clearly for the initial interference to decrease as the plant goes to operating temperature and pressure.

### Finite Element Models

Second order effects such as deflection and ovalization of oblique nozzles under pressure loading are assessed by finite element modeling of the nozzle and vessel head. Each of the NSSS vendors and EPRI has models of reactor vessel top head nozzles. Figures 4 and 5 show typical models of central and peripheral row CRDM nozzles and the associated J-groove welds. The models shown include the nozzle, a sector of the vessel shell, J-groove weld, J-groove weld buttering, and vessel cladding. Boundary conditions are imposed on the sector of the vessel shell to simulate the nozzle being installed in a complete spherical shell, and to model the initial

interference fit of the nozzle in the vessel shell. Welding residual stresses are simulated by multiple weld passes, each including a thermal analysis followed by a structural analysis to compute the weld shrinkage effects. Elastic-plastic material properties are used to model localized yielding produced by the welding.

#### Effect of Ovalization on Nozzle Fit

Finite element analyses show that oblique CRDM nozzles displace laterally if a clearance opens up between the nozzle and bore under operating conditions. The resultant displacement reduces the leak path at some locations and increases the leak path at other locations. Typical analysis results for a peripheral CRDM nozzle are shown in Figure 6. The net effect shown in this figure is to open up a spiral leak path which has less flow resistance than a uniform annular gap.

#### Effect of Flange Rotation on Nozzle Fit

Finite element analyses of a model including the nozzle, vessel shell, and flange show that flange tensioning and resultant rotation increase the ovality of peripheral row CRDM nozzles by approximately 20%. This effect is small and, as noted in the previous paragraph, should decrease the flow resistance.

#### Conclusions Regarding Operating Condition Nozzle Fit

Analyses show that the operating conditions tend to reduce the interference fit between the nozzle and hole in the vessel head. The calculations, considering the best-estimate values for the nozzle and head coefficients of thermal expansion, demonstrate that leakage should be detectable for most reactor vessel head nozzles (see Section 3.0 Comments 1 and 2 for further details).

The effect of ovalization in oblique nozzles and flange rotation are primarily to change the shape of the leak path from annular to a spiral leak path. This has the beneficial effect of decreasing the flow resistance.

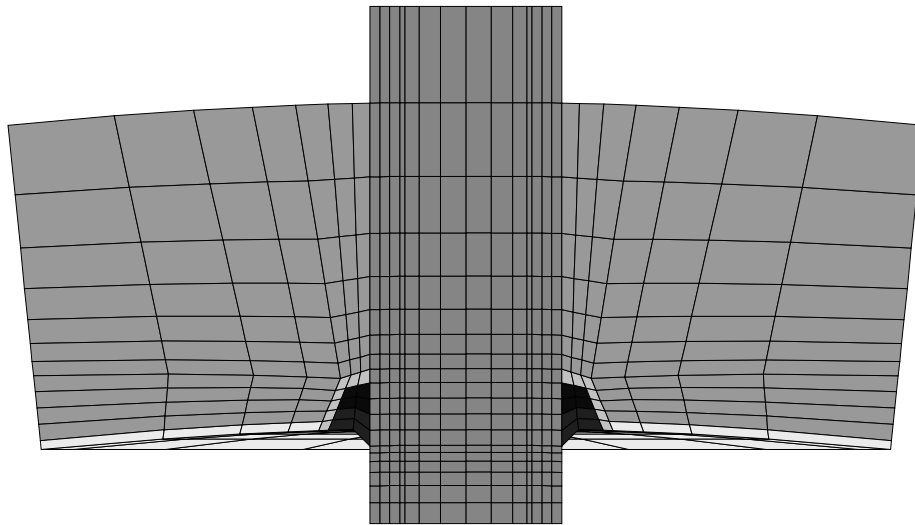

Figure 4  
Typical FEA Model of Central CRDM Nozzle

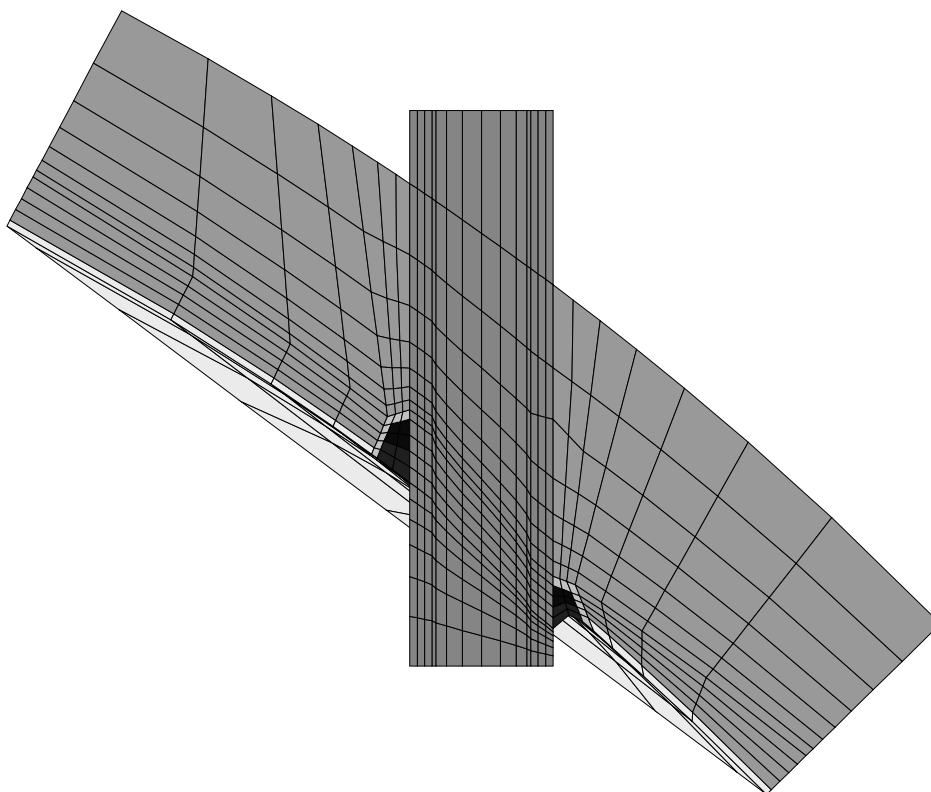

Figure 5  
Typical FEA Model of Peripheral Row CRDM Nozzle



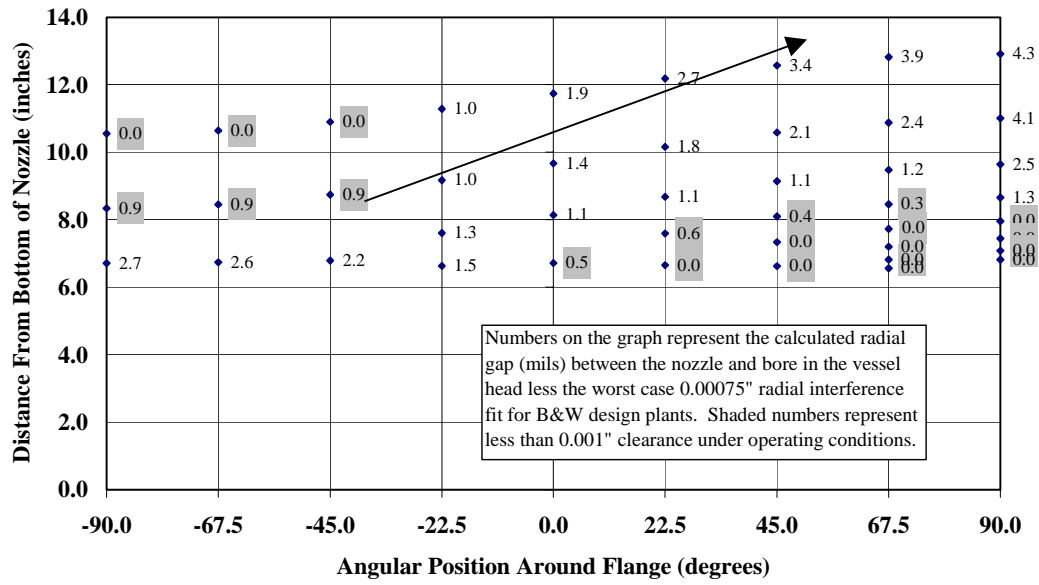

Figure 6  
Effect of Nozzle Ovalization on Fit

**Section 3.0 Comment 4**

*"Assuming a leak path by way of a through-wall flaw in the CRDM nozzle into the annular region of the RPV head and then up and out onto the RPV head, provide a detailed description of any predictive modeling of this scenario which has been performed, or is planned. Specific attention should be given to the evaluation of the expected leakage from VHPs having potentially greater interference fit values. Based on the information provided in the MRP-44, Part 2 report, such a modeling effort, appropriately benchmarked against the information provided in response to item (2) above, could be used (along with accurate crack growth data) to evaluate the leakage from any VHP. This could demonstrate whether leakage could occur prior the growth of such a flaw to a size that could challenge primary system integrity."*

The MRP has not performed calculations to estimate the leak rate from tight PWSCC cracks and from annular gaps with a small clearance or interference fit. Rather, the approach has been to rely upon field experience.

Experience over the past 15 years has been that leakage from many Alloy 600 nozzles attached to pressure boundary parts by J-groove welds has been small. In some cases, the leakage has only resulted in a small ring of boric acid crystals at the location where the nozzle penetrates the pressure boundary despite the nozzles having been installed with a clearance fit. This suggests that these leaks are limited by the tight PWSCC cracks rather than by the annulus between the nozzle and bore.

On the other extreme, 2250 psi water can leak past a tight fit produced by roll expansion in some cases (see Section 3.0 Comment 1 for further details).<sup>1</sup>

In summary, the small volumes of boric acid crystal deposits at Oconee and ANO-1 are considered to have resulted primarily from the tight PWSCC cracks rather than the small interference fit between the nozzle and vessel shell. It is not considered that calculations to predict these small amounts of leakage would produce useful results.

---

<sup>1</sup> PWSCC of Alloy 600 Materials in PWR Primary System Penetrations, EPRI, Palo Alto, CA: 1994. TR-103696.

**Section 3.0 Comment 5**

*"Provide additional technical justification, based on a consideration of the physical processes involved, as to why boric acid crystal and/or corrosion product plugging should not be considered when evaluating the potential leakage from the VHPs. This additional information should consider the potential for substantial plugging of the assumed leak path based upon different specific crack morphologies, different interference fits, and/or different operational stresses, which could lead to potentially smaller effective crack opening areas."*

As previously discussed, experience with CRDM nozzle leaks at Oconee and ANO-1 has shown that leakage from significant through-wall cracks can be detected by careful visual inspection of the RPV top head surface. Plugging did not prevent leakage from being detected at these plants, even though it is suspected that some of the leaks may have been active for several years.

Further evidence that plugging will not prevent leaks is provided by the fact that roll expansion did not prevent leakage of 2250 psi water in the case of some EDF pressurizer instrument nozzles.

### **Section 3.0 Comment 6**

*"At a public meeting on June 7, 2001, at NRC headquarters, the industry representatives described visual examinations conducted under the insulation at several PWRs. Provide any photographic documentation that can serve to demonstrate the expected conditions, accessibility and inspectability of the RPV head for such arrangements."*

Visual inspections were performed of vessel top head surfaces at several plants during the Spring 2001 refueling outages. The attached photographs show the top head surfaces of six of the plants that carried out inspections of all nozzles. Several different methods were used to perform the visual inspections of the vessel top head surfaces.

- Figure 7 is Oconee 3, where visual inspection was performed through access ports that had previously been cut in the shroud. Leakage is clearly visible in the photograph.
- Figure 8 is Salem 1, where the shroud was raised several feet and the outer vertical panels of reflective insulation were removed. This provided excellent visual inspection conditions. No leakage was detected.
- Figure 9 is H. B. Robinson 2, where the original reflective type insulation was removed, and then replaced by blanket type insulation after the inspection was completed. No leakage was detected.
- Figure 10 is Prairie Island 1, where the head was modified to provide for visual inspection. No leakage was detected.
- Figure 11 is Farley 2, where the inspection was performed using a video probe inserted at joints in the metal reflective insulation. No leakage was detected.
- Figure 12 is ANO-1, which performed inspections using a crawler inserted through a small hole in the shroud. Leakage is clearly visible in the photograph taken from the video camera record of the inspection.

The main conclusion from these photographs is that a number of plants have been able to perform visual inspections of the vessel top head surface, including the locations where the nozzles penetrate the vessel head surface. It is important to note that each of these plants used a different approach to provide access. It is likely that good inspection access can be provided for all PWR plants, although the effort to achieve good inspection conditions will vary from plant to plant, and may be quite expensive and dose intensive for some.



Figure 7  
Visual Inspection of Oconee 3 Reactor Vessel Head (Leaking Nozzle 56)



Figure 8  
Visual Inspection of Salem 1 Reactor Vessel Head



Figure 9  
Visual Inspection of H. B. Robinson 2 Reactor Vessel Head



Figure 10  
Visual Inspection of Prairie Island 1 Reactor Vessel Head



Figure 11  
Visual (Video) Inspection of Farley 2 Reactor Vessel Head (Nozzle 25)



Figure 12  
Visual (Video) Inspection of ANO-1 Reactor Vessel Head (Leaking Nozzle 56)

## **Section 4.0 Comment 1**

*"The simplified ranking model proposed in the subject report is based on the consideration of plant operating time and head temperature. In calculating the operating time at equivalent temperature, an Arrhenius equation was used with an activation energy of 50 kcal/mole. The staff notes that this 50 kcal/mole value is based on the evaluation of PWSCC in steam generator tubes. The staff is continuing to evaluate whether or not this value is acceptable given the mechanistic nature of the cracking observed in the CRDM penetrations. Discuss the sensitivity of the relative plant susceptibility rankings to the selection of a specific activation energy value, and whether a range of activation energy values would be more appropriate."*

The 50 kcal/mole used as an activation energy for the time-at-temperature histogram in the Interim Safety Assessment is a best-estimate value for PWSCC initiation in Alloy 600 for the temperature range of interest (550-610°F; 285-320°C) as discussed in EPRI NP-7493.<sup>2</sup> Because the time for initiation is longer than the time for crack growth, the appropriate activation energy value for assessing the potential for reactor head nozzle cracking is 50 kcal/mole. EDF has published a lower experimentally determined activation energy of 44 kcal/mole for PWSCC initiation in Alloy 600 reactor head nozzle material for the temperature range of interest.<sup>3</sup>

In order to respond to the staff's request, the time-at-temperature histogram reported in the Interim Safety Assessment was recalculated using a lower activation energy of 40 kcal/mole to assess the sensitivity of the analyses to activation energy. The results are compared in the following table, which shows a small effect. Several plants shift into an adjacent group, and there is only one case where a plant shifts by more than one group (one plant shifts from the "20-30 EFPYs" group to the "10-15 EFPYs" group). In summary, the activation energy does not have a significant effect for the purposes of the time-at-temperature histogram. Note that Table 1 reflects the set of time and temperature inputs at the time of submittal of the interim safety assessment, and that inputs for some plants have been revised since that time as part of the verification process.

---

<sup>2</sup> *Statistical Analysis of Steam Generator Tube Degradation*, EPRI, Palo Alto, CA: 1991. NP-7493.

<sup>3</sup> Amzallag, C., et al., "Stress Corrosion Life Assessment of Alloy 600 PWR Components," *Ninth Intl. Symposium on Environmental Degradation of Materials in Nuclear Power Systems—Water Reactors*, Edited by F. P. Ford, et al., The Minerals, Metals & Materials Society (TMS), Newport Beach, 1999.



Table 1  
Effect of Activation Energy on Time-at-Temperature Assessment Groups

<i>Activation Energy</i>	<i>Assessment Groups</i>							
	< 3 EFPY <sub>s</sub>	3-6 EFPY <sub>s</sub>	6-10 EFPY <sub>s</sub>	10-15 EFPY <sub>s</sub>	15-20 EFPY <sub>s</sub>	20-30 EFPY <sub>s</sub>	30-50 EFPY <sub>s</sub>	> 50 EFPY <sub>s</sub>
<b>50 kcal/mole</b>	<b>12</b>	<b>3</b>	<b>10</b>	<b>8</b>	<b>6</b>	<b>6</b>	<b>2</b>	<b>22</b>
<b>40 kcal/mole</b>	<b>12</b>	<b>4</b>	<b>14</b>	<b>9</b>	<b>4</b>	<b>3</b>	<b>2</b>	<b>21</b>

**Section 4.0 Comment 2**

*"Based on your simplified ranking model, all U.S. PWRs are assigned into one of eight assessment groups relative to the time it takes, in effective full power years (EFPYs), to reach equivalency to Oconee Unit 3. The number of plants in each group, including a summary of their inspection status, was provided in Figure 4-1. In order for the staff to complete its review of this information, identify by name which plants are in each of the assessment groups and provide the head temperature, operating time (in EFPY), effective degradation years based on your model, and interference fit classification for each facility. Also provide, on a plant-by-plant basis, a review of the inspection history (i.e., when were inspections conducted, how were the inspections performed and scope thereof, what were the results, etc.) for each facility and a schedule of each facility's upcoming refueling outages."*

Attached Table 2 provides the requested data for the plants in the top three assessment groups with refueling outages scheduled for Fall 2001. Table 2 also lists the nozzle material supplier, head fabricator, and insulation type for these plants. Data for the remaining plants is currently being confirmed prior to submittal to the NRC staff. It is expected that the inputs to the time-temperature assessments will be revised for some plants as the processes by which the input data are generated are further standardized. Generally, any changes to the inputs are expected to be relatively small.

Table 3 is a summary of the results of the visual inspections of the top head surface that have been performed since 1994 at 21 units. Of the 1035 CRDM, CEDM, and ICI nozzles that have been inspected for leakage, the only leaks that have been observed are from 15 CRDM nozzles in the three Oconee units and ANO Unit 1. The detailed results of NDE inspections of the inside surfaces of CRDM, CEDM, and ICI nozzles in seven units (Point Beach 1, Cook 2, Oconee 2, Palisades, North Anna 1, Millstone 2, and Ginna) have already been provided to the NRC staff by the individual licensees.

Table 2  
Key Parameters for Plants in Top Three Assessment Groups With Fall 2001 Refueling Outages

Content Deleted –  
EPRI Proprietary Information

Table 3  
Results of Visual Inspection of Reactor Top Head Surfaces Since 1994

No.	Unit	NSSS Supplier	Date (Start of Outage)	Number of Nozzles on Head				Number of Nozzles Inspected					Leaking Nozzles <sup>2</sup>	
				CRDM	CEDM	ICI	Total	CRDM	CEDM	ICI	Total	Total %	CRDM <sup>3</sup>	% of Total Inspected
1	Cook 1	W	Feb-94	79			79	26			26	32.9%	0	0.00%
2	Turkey Point 4	W	Mar-94	65			65	3		3	4.6%	0	0.00%	
3	Palisades	CE	May-95		45	8	53		45	8	53	100.0%	0	0.00%
4	Farley 1	W	Sep-95	69			69	32		32	46.4%	0	0.00%	
5	TMI 1	B&W	Sep-99	69			69	69		69	100.0%	0	0.00%	
6	Crystal River 3	B&W	Oct-99	69			69	69		69	100.0%	0	0.00%	
7	Davis Besse	B&W	Mar-00	69			69	69		69	100.0%	0	0.00%	
8	Prairie Island 2	W	Apr-00	40			40	40		40	100.0%	0	0.00%	
9	San Onofre 2	CE	Oct-00		91	10	101		24	10	34	33.7%	0	0.00%
10	Oconee 1 <sup>1</sup>	B&W	11/22/00	69			69	69		69	100.0%	1	1.45%	
11	San Onofre 3	CE	1/2/01		91	10	101		24	10	34	33.7%	0	0.00%
12	Prairie Island 1	W	1/19/01	40			40	40		40	100.0%	0	0.00%	
13	Oconee 3	B&W	2/16/01	69			69	69		69	100.0%	9	13.04%	
14	Farley 2	W	2/24/01	69			69	69		69	100.0%	0	0.00%	
15	McGuire 1	W	3/9/01	78			78	11		11	14.1%	0	0.00%	
16	ANO 1	B&W	3/16/01	69			69	69		69	100.0%	1	1.45%	
17	Calvert Cliffs 2	CE	3/16/01		65	8	73		0	8	8	11.0%	0	0.00%
18	St. Lucie 1	CE	4/2/01		69	8	77		2	0	2	2.6%	0	0.00%
19	Salem 1	W	4/6/01	78			78	78		78	100.0%	0	0.00%	
20	Robinson 2	W	4/6/01	69			69	69		69	100.0%	0	0.00%	
21	Oconee 2	B&W	4/25/01	69			69	69		69	100.0%	4	5.80%	
<i>Totals for All Inspections</i>				1070	361	44	1475	851	95	36	982	66.6%	15	1.53%
<i>Totals for Inspections (Oconee 1 and Later)</i>				610	225	26	861	543	26	18	587	68.2%	15	2.56%

## NOTES:

<sup>1</sup>Five of eight small-bore thermocouple nozzles at Oconee 1 were found to be leaking in late 2000, and no circumferential cracks were detected in the eight thermocouple nozzles.

<sup>2</sup>Of the 15 CRDM nozzles found to be leaking, three (3) were found to have circumferential above-weld cracks (two at Oconee 3 and one at Oconee 2).

<sup>3</sup>No CEDM or ICI nozzles have been found to be leaking.

**Section 4.0 Comment 3**

*"In Table 2-1, a summary of worldwide CRDM nozzle PWSCC experience was provided. Provide the rankings, by use of the model proposed in your report, of those foreign PWRs experiencing cracking in their CRDM nozzles. Discuss the reliability of your simplified model when benchmarked against the inspection results of the foreign PWRs."*

The time-at-temperature histogram has not been benchmarked against foreign PWR plants. It is intended only as a ranking tool for prioritization of US plants.

With regard to leakage, the only plant with a previously known leak that could be considered for benchmarking purposes was Bugey 3. However, the heat treatment process used for CRDM nozzles in EDF plants was considerably different from that used at most domestic PWR plants and is, therefore, not considered directly applicable.

All plants are expected to have similar weld metal properties, but the evidence at Oconee and ANO-1 suggests that the majority of the cracks initiated at the outside surface of the Alloy 600 base metal rather than in the welds.

**Section 4.0 Comment 4**

*"In the subject report, the recommended inspection of nine plants for fall outage 2001 is based on consideration of the 25 plants in the first three assessment groups that have equivalent time at temperature to be within 10 EFPY of the Oconee 3 condition. Explain the basis for selecting the 10 EFPY cut off criteria for near-term inspection. Additionally, provide justification for not selecting for re-inspection plants with high rankings that were only partially inspected in the past."*

The 10 year cutoff criterion was established by engineering judgment and by a Weibull analysis of the leakage experience at Oconee and ANO-1. A Weibull analysis was used since it provides a statistical model that shows the expected distribution of failures as a function of time. Industrial experience has shown that Weibull analyses provide good models for occurrence of PWSCC, both in nozzles and in steam generator tubes, as well as in laboratory SCC tests.

Figure 13 shows the fraction of leaking nozzles at Oconee 1, Oconee 2, Oconee 3 and ANO-1 plotted versus the effective degradation years (EDYs) adjusted to 600°F. The time to a first leak at Oconee 2 and 3 was estimated using a Weibull slope of 3 which is typical for PWSCC of Alloy 600 materials in the temperature range of interest. The data in this figure suggest that the initial leaks at Oconee 2 and 3 most likely occurred prior to initial detection in 2001.

Content Deleted –  
EPRI Proprietary Information

Figure 13  
Weibull Plot of Fraction of Nozzles With Leaks vs. Effective Degradation Years

The current MRP recommendation is that plants that are within 10 effective full power years (EFPYs) of Oconee 3 based on effective time at temperature, and having Fall 2001 refueling outages, should perform a visual inspection of the reactor vessel top head capable of detecting small amounts of leakage similar to that observed at Oconee and ANO-1. These recommendations apply regardless of previous head inspections performed at a plant. The need for reinspection each outage will be reassessed by the MRP based on industry assessments of the inspection results from the Fall 2001 outages.

**Section 4.0 Comment 5**

*"In the last sentence of the "Summary" section of Section 4, it is stated that "[s]ince the Oconee units lead the industry in effective time at temperature, and 10 EFPYs margins [have] been added to account for uncertainties when planning inspections, there is assurance that significant cracking at any of the US PWRs will be detected before there is any significant impact on plant safety." The staff notes that, in the subject report, the potential crack growth rate (CGR) in the affected nozzles was not discussed. The Alloy 600 and Inconel 182 CGRs are affected by a number of factors (e.g., surface cold work, residual stresses resulting from welding, operating stresses, component geometry and material properties – strength and sensitization), in addition to operating temperature. Explain what technical basis was used for establishing the assumed CGR for the circumferential CRDM nozzle cracking. Provide a detailed justification, based on this assumed CGR, as to why the proposed inspection plan (based on operating time and temperature) will provide adequate assurance that significant cracking will be detected in U.S. PWRs prior to having an impact on plant safety."*

Plants have adequate assurance that significant cracking will be detected prior to having an impact on plant safety for several reasons:

- Other plants lag the Oconee plants from the standpoint of time at temperature,
- Leakage is expected to be detectable in most nozzles due to the similar designs and interference fits that were confirmed in leaking Oconee and ANO-1 nozzles,
- Visual inspections, and increased sensitivity to small leaks, should assure that leaks will be detected earlier than they were at Oconee, and
- It is predicted that it would have taken more than 4-5 years for the Oconee nozzles to have reached typical allowable structural margin (see response to Section 5.0 Comment 1).

The results of the inspections performed during the Fall 2001 outages will be used by the MRP to develop longer term recommendations and programs.



## **Section 4.0 Comment 6**

*"Discuss the potential for additional measures, such as acoustic monitoring, for monitoring the RPV head and detecting leakage."*

Several approaches to enhanced reactor vessel leakage detection are available.

- Acoustic Emission  
Framatome ANP GmbH (Siemens) offers an ALUS acoustic leakage monitoring system that records high-frequency structure-borne noise generated by fluid discharging through leaks in pipes, tanks, vessels and valves. The location of the leak, and approximate leak rate, are determined from the amplitude of the noise signal that decays as a function of its distance from the leak. Leak rates of greater than 150 kilogram/hour are detectable with this system.
- Radiometric  
Merlin Gerin Provence (Schneider Group) offers a VICNIS system to detect leak rates of 1 liter/hr (0.004 gpm) within 1 hour based on radiometric N13 measurements. These systems were installed on more than 10 EDF plants during the period before the closure heads in these plants were replaced (1993-96).
- Hydrometric  
Framatome ANP GmbH (Siemens) offers a FLUS system to detect moisture from leaking components. Steam from a leak is pulled into a hose and is transported with air inside the hose to a moisture sensor. The moisture sensor is used to determine the size and location of the leak based on the moisture level and the transport time. This system is capable of detecting leak rates of 1 liter/hour (0.004 gpm) within 1 hour. These systems have been installed in plants in Germany, Sweden, Slovakia, and Canada.

These systems are not sufficiently sensitive to detect the very small amounts of leakage from the PWSCC cracks as evidenced by the small amounts of boric acid crystals at Oconee and ANO-1. However, it is possible that these systems could provide earlier warning of a significant leak prior to nozzle rupture than is possible using existing plant leakage detection systems.

The potential usefulness of these leakage detection systems will be considered by the MRP and addressed in the final safety assessment report for CRDM nozzle PWSCC.

### **Section 5.0 Comment 1**

*"The staff noted that, in the subject report's evaluation of structural margins, no consideration was apparently given to the impact of CGR on the margins. Explain what impact the assumed CGR would have on the assessment of structural margins. In particular, explain how long Oconee Unit 3 could have operated based on the assumed CGR before it reached a critical flaw size."*

The time for the Oconee 3 circumferential cracks above the J-groove weld to grow from the reported 165° arc length to the allowable 273° arc length noted in Section 5.0 of MRP-44 was computed as at least 4-5 years by two independent methods.

Both calculations were performed assuming that the cracks propagate in a circumferential direction around the nozzle from both crack fronts as shown in Figure 14. This is consistent with inspection results from Oconee 3 which showed that the cracks had essentially the same arc length on the inside and outside surfaces and is also consistent with the expected direction of primary crack growth for a through-wall crack in a cylindrical shell under internal pressure loading. Note that the finite element stress analysis results reported under Section 5.0 Comment 3, show that when the crack has reached 180° arc length, the welding residual stresses have been significantly reduced such that the primary direction of crack growth is expected to be around the nozzle as shown.

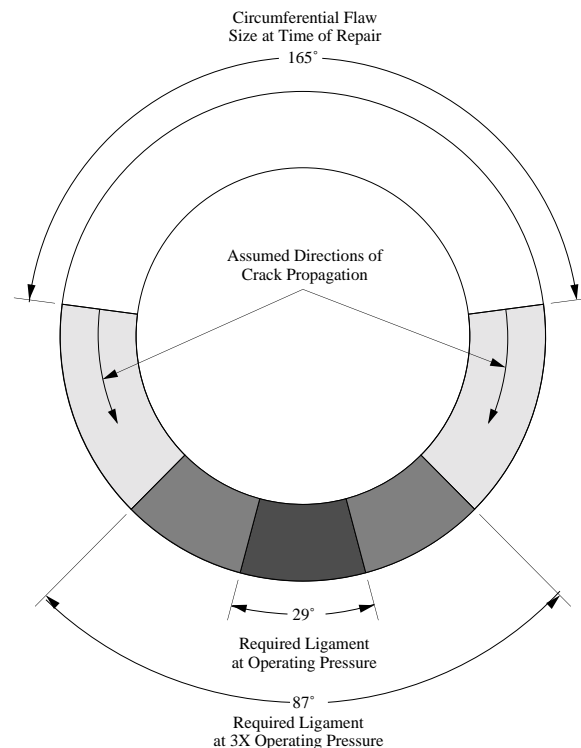

Figure 14  
Direction of Crack Propagation

Both calculations are based on available crack growth data for Alloy 600 base metal in a PWR environment. Work will be performed this summer to assess the available crack growth data and to determine if additional tests are required. This effort will include an assessment of the environment in the annulus after a through-wall leak occurs. There are two bases for using crack growth rates in normal PWR environments at present:

- The review of fabrication records described under Section 5.0 Comment 2 shows that the materials were carefully cleaned during assembly.
- EDF has reported on tests of notched specimens in a concentrated environment (10.1% B<sub>2</sub>O<sub>3</sub>, 2.2% Li<sub>2</sub>O, 4 bar H<sub>2</sub>) at 315°C (600°F) and 14.9 and 29.9 MPa√m. The crack growth rates were less than the maximum crack growth measured in other laboratory tests (see Vaillant, et. al., EPRI TR-105406<sup>4</sup>).

The two analysis methods used to calculate the remaining time for the Oconee 3 through-wall circumferential cracks to have reached the minimum ligament to support three times the system design pressure are as follows:

- Method 1: Calculation Based on Maximum Crack Growth Measured in Laboratory Tests  
The first approach was to assume the maximum crack growth rate measured in any of the crack growth tests of Alloy 600 base metal in PWR environments. Tests performed by Westinghouse (EPRI TR-109136<sup>5</sup>) showed a maximum crack growth rate of  $4.6 \times 10^{-10}$  m/sec (14.5 mm/yr) at 325°C (617°F) for an applied stress intensity of 50 MPa√m. Adjusting these data to the Oconee head temperature of 602°F using an activation energy of 33 kcal/mole for crack growth gives a crack growth rate of 9.8 mm/yr. At this growth rate it would take 4.1 years to propagate the remaining 54° on each side of the nozzle to reach the allowable 273° flaw size shown in Figure 5-1 of the interim safety assessment report (MRP-44).
- Method 2: Calculation Based on Stress Intensities and Peter Scott Crack Growth Model  
The second approach was to assume a conservative axial stress in a cylindrical shell with a through-wall crack, calculate the crack tip stress intensity using a through-wall center cracked panel model, and then determine the crack growth rate from the Peter Scott model. The axial stress was conservatively estimated from intact finite element analysis results, including the effect of welding residual stresses, to be 20 ksi. This assumed stress is approximately 10 times the normal axial pressure stress in the nozzle and about 40% of the nozzle yield strength. The calculation was performed to determine the time for a flaw to grow from 180° to 270°. The crack tip stress intensity was calculated to be 65 ksi√in at 180° and 100 ksi√in at 270°. Crack growth was computed using the modified Peter Scott

<sup>4</sup> F. Vaillant, D. Buisine, and F. Picard, "PWSCC of Reactor Vessel Penetrations in Alloy 600 Crack Growth Rate Evaluations," *Proceedings: 1994 EPRI Workshop on PWSCC of Alloy 600 in PWRs*, EPRI, Palo Alto, CA: 1995. TR-105406.

<sup>5</sup> *Crack Growth and Microstructural Characterization of Alloy 600 Vessel Head Penetration Materials*, EPRI, Palo Alto, CA: 1997. TR-109136.

model of  $2.8 \times 10^{-12} (K-9)^{1.16}$  m/sec at 330°C (626°F), where  $K$  is in MPa√m.<sup>6</sup> Using this model it was calculated that it would take the through-wall crack 4.8 years to grow from 180° to 270°.

In summary, the models predict that it would take at least 4-5 years for the Oconee 3 circumferential cracks above the J-groove weld to grow to the allowable size shown in Figure 5-1 of the interim safety assessment report.

Further effort is currently being sponsored by the MRP to refine the calculations of stress intensity as the crack propagates around the nozzle. It is expected that the refined calculations will show lower stress intensities than the values used above.

---

<sup>6</sup> *Ibid.*

**Section 5.0 Comment 2**

*"Discuss the effect that potential contaminants, such as organics and fabrication fluids, could have on the crack initiation and CGR of circumferential flaws in Alloy 600 nozzle material."*

The following is a review of methods used by Combustion Engineering and Babcock & Wilcox to clean the nozzles and vessel head to preclude contamination of this area during fabrication.

- Cleaning of CRD Housings in Combustion Engineering Fabricated Vessel Heads  
CRD housings received from the machine shop were stored in wooden crates to prevent damage and to maintain cleanliness. After receipt from the machine shop, a dye penetrant inspection was performed on each housing. Upon completion of the dye penetrant exam, the nozzles were cleaned with acetone, placed back into the wooden crates, which were lined with plastic. Plastic wrap covered each housing. The housings were stored in crates until time for installation in the head. The housings were cleaned again with acetone prior to installation in the liquid nitrogen tank used to shrink the housings prior to installation.

All surfaces of the vessel closure heads, including the penetration holes, were cleaned to remove machining oils prior to each required heat treatment. The CRD housings were installed after the final post weld heat treatment. The fabrication travelers specified that the penetrations be cleaned prior to installation of the housings. The cleaning was accomplished using a fine grade of "Scotchbrite" soaked in acetone to remove surface oxides from heat treat and general atmospheric conditions. Finally, the penetrations were wiped with white rags soaked with acetone prior to installing the housings.

- Cleaning of Nozzles in Babcock & Wilcox Fabricated Vessel Heads  
The following cleaning practices for B&W fabricated vessel heads are based on a preliminary review of procedures.

Prior to welding the upper adapter flange (and dutchman on some CRDMs) to the nozzle body, all foreign material in the area of the weld preps was removed using approved solvents such as technical grade acetone.

After welding and subsequent final machining, and prior to PT and dimensional inspections, the nozzles and bores were cleaned using approved solvents. After the CRDM nozzle outside surface was ground, the CRDM nozzles were cleaned for final PT and dimensional inspection. The nozzles were cleaned again after completion of the PT. The CRDM nozzles were then packaged in moisture proof barriers, such as polyethylene sheet, packaged in wooden boxes with the necessary dunnage or pads to prevent damage and shipped to the closure head manufacturer.

Prior to installing the CRDM nozzles into the closure head, the closure head penetrations were cleaned as described above. Prior to welding the installed CRDM nozzles to the

closure head, the weld preps were cleaned using approved solvents. The welds were cleaned again after welding, and before and after PT examination.

After hydrostatic testing using demineralized water, the vessels were visually inspected for evidence of any foreign material. Desiccant was installed in the vessels, and covers were installed during shipment.

In summary, while contaminants could possibly increase crack growth rates of Alloy 600 materials, fabrication practices were established by Combustion Engineering and Babcock & Wilcox to prevent contamination in vessels.

**Section 5.0 Comment 3**

*"At a public meeting on June 7, 2001, at NRC headquarters, the industry representatives described finite element analyses (FEA) for circumferential cracks in peripheral CRDM nozzles. Provide details of the FEA modeling assumptions (such as symmetry, boundary conditions and residual stresses), the resultant stresses, and the applied stress intensity factors. How do these parameters change (e.g., stress redistribution) with crack growth in the nozzles?"*

Finite element models of CRDM nozzles have been developed by each of the NSSS vendors and EPRI. Typical models are described under the response to Section 3.0 Comment 3 and in previous submittals to the NRC in 1993-94. Typical models for central and peripheral row nozzles shown in Figures 4 and 5 have 180° symmetry and boundary conditions imposed on the sectors of the head shell to simulate an infinite shell. The J-groove welds in these models were simulated by combined thermal and structural analyses. A transient thermal analysis was used to generate nodal temperature distributions throughout the welding process. These nodal temperatures were then used as inputs to structural analyses which calculated resultant thermally-induced residual stresses as the welds cooled and gained strength. The sequence of thermal analysis followed by structural analysis was duplicated for each simulated weld pass.

Analysis results were presented at the June 7 meeting showing stresses parallel to and perpendicular to the J-groove weld for a peripheral nozzle in the intact operating condition, including the effects of welding residual stresses and hydrostatic testing prior to operation, and with the weld cracked 180° around on the uphill side of the nozzle at the elevation of the weld root. These results are repeated in Figure 15, which also shows the values for the stress contours. These data show that stresses are significantly reduced after cracking has removed some of the constraint that caused high welding residual stresses.

The model shown in Figures 4, 5 and 15 was not used to calculate crack tip stress intensity factors directly. Stress intensity factor calculations are currently being sponsored by the MRP using the finite element analysis results as inputs. Until such time as the finite element based stress intensity calculations are completed, calculations of crack growth have been performed using more traditional models such as described under Section 5.0 Comment 1.

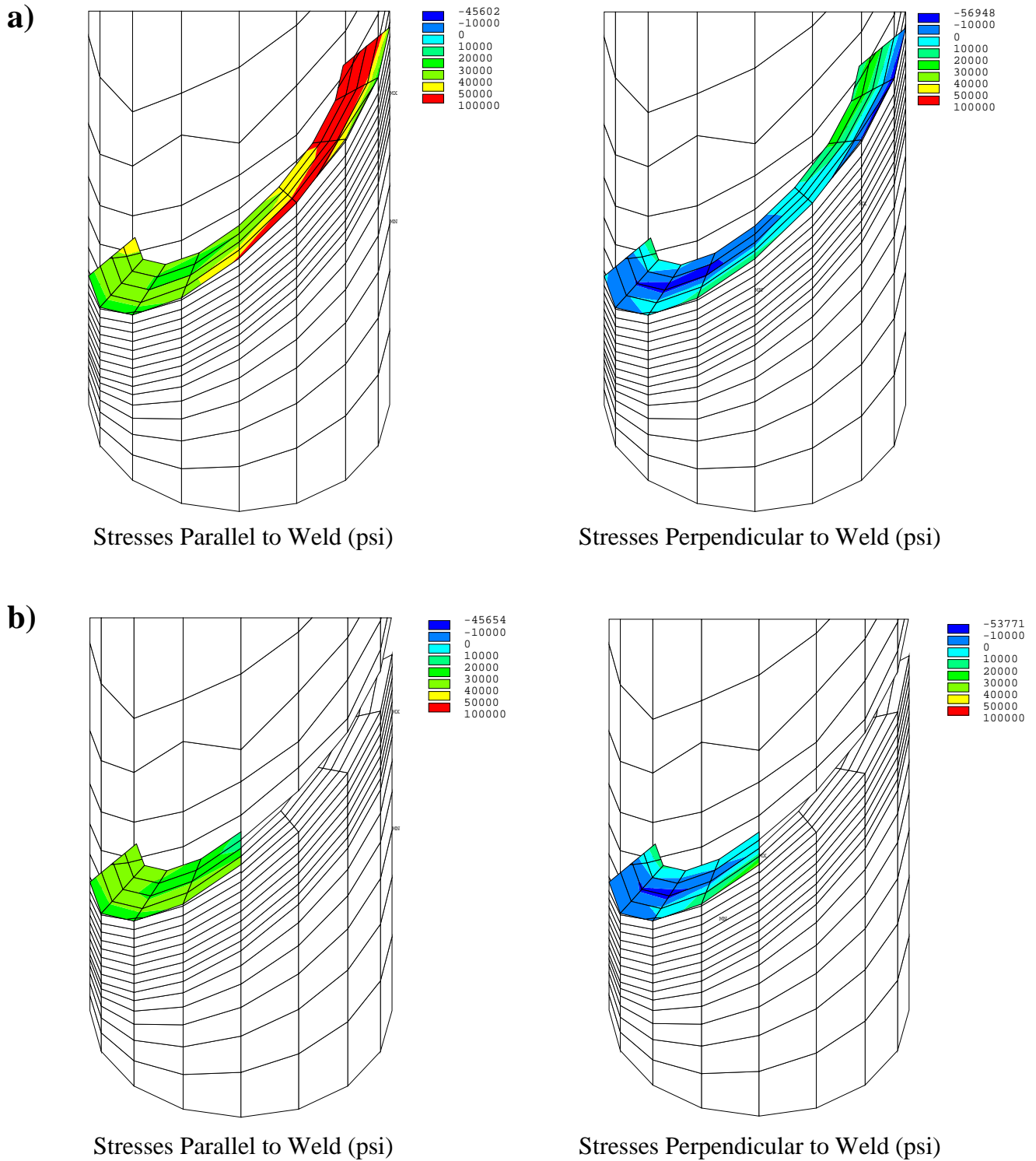

Figure 15  
Stress Analyses of Peripheral CRDM nozzle in Intact (a) and Cracked (b) Configurations



**Risk-Informed Review: Comment 1**

*"Discuss the factors affecting the likelihood, consequence, and compensatory measures for a potential CRDM LOCA, including:*

- a. the probability of having undetected circumferential flaws (e.g., the fit-up between the CRDM nozzle housing and the RPV head being sufficiently tight that there is too little evidence of boron crystal deposits to be detectable using a VT-2 visual examination);*
- b. the potential likelihood of CRDM nozzle housing rupture due to undetected circumferential cracks propagating to a critical flaw size (discussion should include installation/repair stresses and weld history, age and temperature history, and chemistry excursions); and*
- c. the potential likelihood of CRDM ejection following a postulated rupture."*

Calculations of the requested probabilities are now underway, but are not yet complete. Calculations are being carried out from two complementary points of view. The first is based on the statistics of the head penetration inspections which have been carried out over the past ten years, and the second is based on a probabilistic fracture mechanics approach. These two approaches are expected to provide complementary answers. The consequences of such an event are also being evaluated, and will be combined to provide a measure of the change in core damage frequency as a result of this issue.

The likelihood of a CRDM LOCA is expected to be extremely low, for a number of reasons. First, very few circumferential cracks have been observed in the many penetrations that have been inspected. The rate of crack propagation is known, from reliable experimental results which are being reviewed by an expert panel. Crack penetration in the circumferential direction above the attachment weld appears to be limited by significant regions of low tensile or compressive axial stresses as the crack progresses around the penetration based on the stress analysis results described in Section 5.0 Comment 3. Even at 165°, the flaw length would have to double to reach the required ligament to keep the nozzle intact at operating pressure.

Results of the ongoing work will be communicated to NRC staff as soon as they are available. Preliminary results are expected before the fall outage season. However, the following factors are expected to limit the probability of nozzle ejection in plants that have not yet performed enhanced visual inspections for leakage:

- All such plants have less time at temperature than the Oconee units.
- The absence of leakage was verified at four of the seven plants that performed full visual inspections since the Oconee 1 leak was discovered. No circumferential above-weld cracking was discovered at five of the seven plants that performed full visual inspections since the Oconee 1 leak was discovered.

- Analyses indicate that the crack growth rate slows as the high welding residual stresses are relieved by the presence of the circumferential crack.

**Risk-Informed Review: Comment 2**

*"Discuss the accident progression given a CRDM ejection following a postulated rupture including, but not limited to, the likelihood of core uncovering, ATWS, and/or disrupted geometry. As part of this discussion, provide a detailed explanation of plant system response to such an event. This discussion should focus on mitigating or compensatory measures and core damage prevention strategies in the event of assembly ejection, ATWS, and LOCA scenarios. The discussion should also include consideration of secondary effects (e.g., insulation blown off by LOCA blocking recirculation system, collateral damage on adjacent CRDMs caused by the ejected CRDM, etc.)."*

In the unlikely event that one or more control rod drive mechanism (CRDM) penetrations were to fail, the resultant transient would be similar to that of a hot leg break LOCA in the small to medium size range. Plants typically operate with the control rods either fully withdrawn or only slightly inserted such that there would be very little positive reactivity inserted as a result of control rod ejection during power operation. If the plant happened to be in an initial condition where the control rods were inserted and a reactivity excursion did occur, the size of the excursion would depend on the initial plant conditions, the number of rods ejected and the associated rod worth. Reactor power would initially be turned by doppler due to the rise in fuel temperature. Reactor shutdown would automatically follow by insertion of the remaining control rods by the reactor protection system. If the loss of inventory were to exceed the capacity of the normal make up system, the loss of reactor coolant system (RCS) inventory would result in a decrease in system pressure and an automatic actuation of the emergency core cooling system (ECCS). The ECCS would inject highly borated water into the RCS to compensate for the loss of inventory due to the LOCA. Injection of highly borated water would also ensure that the reactor remained shutdown following the rod ejection. This event would be a beyond design basis accident if more control rods were to be ejected than were analyzed for. However, plant safety equipment and operator response for this scenario is within the realm of guidance provided in existing generic Emergency Response Guidelines. The resulting LOCA would be bounded by existing design basis analyses and therefore the core would remain covered by borated water which would provide adequate cooling. Core internals would remain in a coolable geometry. The condition of the RCS and containment following this accident would not require implementation of the severe accident management guidelines (SAMGs).

Emergency Operating Procedures at all domestic nuclear power plants are based on generic guidelines developed by a combination of the plant reactor vendor and utility personnel. Those generic guidelines were developed to be in compliance with NUREG-0737, Clarification of TMI Action Plan Requirements, Item I.C.1, Guidance for the Evaluation and Development of Procedures for Accidents and Transients. NUREG-0737, Item I.C.1 specified that multiple events, consequential failures, and operator errors of omission or commission should be considered in development of procedures for transients and accidents. Each vendor's generic guidelines were submitted in the 1980s to the USNRC for review, and NRC Safety Evaluation Reports (SERs) were issued to each vendor. Utilities have all implemented plant-specific EOPs based on vendor-specific generic guidelines and have had subsequent audits by the USNRC to

assure compliance with the generic guidelines and the requirements of NUREG-0737. Operators are routinely trained on implementation of the EOPs on a plant-specific simulator as a requirement for maintaining their NRC operating license. The generic guidelines developed by each reactor vendor are symptom-based and do not require event identification. Following a reactor trip the operators follow plant-specific EOPs that will ensure that all safety functions are being addressed. Existing EOPs provide guidance for all ranges of LOCAs and include coverage for multiple events including reactivity excursions that would occur during the course of an accident. Therefore, no additional operator action recommendations are needed since existing guidelines provide adequate directions to mitigate the transient induced by one or more CRDM penetration failures.

Plants typically operate with the controls rods either fully withdrawn or only slightly inserted such that there would be very little positive reactivity inserted as a result of control rod ejection during power operation. During other modes of operation, a CRDM penetration failure would result in a small to medium size range LOCA with a possible reactivity excursion. The plant EOPs would be implemented following the subsequent auto or manual reactor trip due to the reactivity excursion or loss of system inventory. The existing EOPs provide adequate directions to mitigate the transient. No additional operator guidance is needed to address this event should it occur during Startup, Cool-down or Hot Standby Periods. Therefore, no additional operator training recommendations are needed.

Work is in progress to evaluate the potential impact on adjacent CRDMs caused by the ejected CRDM or by the water escaping through the head.

**Loose Parts Assessment: Comment 1**

*"At a public meeting on April 12, 2001, industry representatives described an evaluation of loose parts, wherein circumferential cracking of the CRDM nozzle below the weld could link two or more axial cracks to form a loose part. Discuss the potential generation and consequences of loose parts generated from degradation of CRDM nozzles."*

**Response for B&W Designed Plants**

Circumferential cracking has been observed on the outside surface of CRDM nozzles at Oconee Unit 3, at the toe of the fillet weld that forms part of the structural attachment to the RV head. Since these cracks are located at or below the weld, they are not considered to be a safety concern from the standpoint of nozzle ejection. However, due to associated through-wall axial cracking in the same location, there is a concern that a through-wall circumferential crack could link up with two or more through-wall axial cracks and form a loose part. An assessment of the potential consequences associated with CRDM nozzle fragmentation has been performed by Framatome ANP. The potential transport of fragments originating at the reactor vessel head penetration were identified and evaluated. The results were presented to the NRC staff during a meeting on April 12, 2001.

If a piece of the CRDM nozzle were to break away, it could potentially end up in one of three places. The first location is the steel plate around the column weldments where it would not likely have an impact on any safety or operational issue in the plant. The second location is through the gaps around the periphery of the plenum cover, and the loose part would likely end up in the steam generator, potentially damaging the tubes or tube welds. The third possibility is that the pieces could enter any one of the 69 column weldments. Based on an area ratio of the column weldments in the upper head and the resultant low flow velocities in this region, there is approximately a 25% chance for a loose piece to enter one of the column weldments. However, this approximation does not consider the possible effect of the lead screw to guide the debris toward entering the column weldment. Therefore, the actual probability may be much higher than 25%.

If fragments enter the column weldments, they will likely be stopped on one of the control rod guide tube brazements where relatively small fragments (<3/4-inch) would be capable of precluding control rod insertion. However, based on experience at Oconee 3, circumferential and axial cracking below the weld is accompanied by through-wall axial cracking at and above the weld. The Oconee experience coupled with the extensive examinations performed in Europe, and the stress analysis results described in Section 3.0 Comment 3, indicate that the predominant cracking orientation is axial. In addition, there have been a total of 27 non-leaking nozzles at both Oconee 1 and Oconee 3 subjected to both eddy current and ultrasonic examinations. Very shallow craze-type cracks were revealed above and below the welds. No OD cracks were detected at the tube to weld intersection (below the weld). These observations and results support the assertion that there is a high probability that detectable leakage would precede the development of a loose part.

---

Response for Westinghouse and Combustion Engineering Designed Plants

An evaluation was performed to evaluate the potential for loose parts from a failed CRDM nozzle to potentially enter a control rod guide tube and prevent the control rod assembly from being fully inserted. It was concluded that there was at least a 25% chance of a loose part entering the guide tube and potentially impairing successful operation of that assembly. It is postulated that if during normal operation, axial and circumferential cracks in the nozzle base metal link together, that only one loose part (per nozzle) will form. It is also perceived that the potential for multiple nozzles to form loose parts during a given fuel cycle is remote. Thus, the possibility to affect more than one control rod is judged highly unlikely. The LOCA and non-LOCA analyses assume that the control rod of highest worth is stuck out of the core. In addition, only a fraction of the remaining worth is used in demonstrating that at least 1% shutdown margin exists at hot zero power conditions.

**Inspection Capabilities: Supplementary Question 1**

*"Discuss the industry's ability to perform volumetric non-destructive examinations (NDE) of the VHPs such that flaws originating either from inside or outside diameter (ID or OD) of the nozzle housing, or through the J-groove weld to the RPV head, can be detected"*

**Detecting Cracks Initiating on the Inside Surface of Nozzles**

In 1994, the industry developed an NDE demonstration program through NEI (then called NUMARC) to detect and characterize axial or circumferential ID-initiated flaws. The inspection process employed by all vendors has been to use eddy current examination (ET) for detecting defects and ultrasonic techniques (UT) to size the defects. These two methods are capable of detecting, locating, and sizing ID-connected axial or circumferential defects.

**Detecting Cracks Initiating on the Outside Surface of Nozzles**

Focus on the inside surface of the penetrations was based on field experience and stress analyses that showed a preference for axial ID-initiated cracking. There was no evidence suggesting concern with crack initiation on the OD nozzle surface or on the J-groove weld as has been recently observed at Oconee and ANO-1. Therefore, there is limited capability to examine for OD-initiated cracking or to qualify the inspection process.

UT is the only practical method identified for directly examining the nozzle OD region from the inside surface of the nozzle. However, the capability of UT to accurately characterize cracks on the OD of the nozzle has not been fully demonstrated and qualified. For example, UT examinations may be affected by the presence of craze cracking on the nozzle ID surface that may require development of techniques to properly interpret crack signals. The MRP is currently evaluating these types of inspection influences and how to address them in a demonstration program. No qualification blocks exist for examination for OD-initiated defects, although the MRP is developing a program for demonstrating the capability to detect and size OD-initiated cracking in the nozzle, both above and below the J-groove weld.

UT to evaluate the extent of condition of OD-initiated flaws was first attempted during the Oconee and ANO-1 outages following discovery of leakage in several CRDM penetrations. The UT techniques applied were site-developed extensions of proven existing techniques for ID inspections that were not specifically designed to assess cracks in the nozzle OD surface. Nonetheless, these site-developed techniques provided useful information to assess the extent of condition and to guide repair decisions. Performance, however, was mixed in that some cracks on the OD surface were clearly detected while other cracks on the OD surface were not. This was not surprising since the techniques were not specifically designed to detect OD surface defects.

The MRP has been in close contact with inspection vendors to review their capabilities and plans to develop tooling and techniques to perform examinations for OD-initiated cracking and for cracking in the J-groove weld. Several vendors are developing this inspection capability. Two vendors have performed examinations of the OD surface of nozzles from the inside of the nozzle. These examinations were performed in a foreign PWR unit of Russian design in which the nozzles are fabricated from stainless steel with stainless steel welds. EDM notches were used to demonstrate the examination capability.

In summary, the basic concept of inspecting for OD surface cracks by UT from the inside of the nozzle is known, but the equipment for these inspections has not yet been properly qualified or optimized.

#### Detecting Flaws within the J-Groove Weld

No volumetric examinations of J-groove welds have been performed domestically. Two vendors examined stainless steel J-groove welds in a foreign PWR unit. The qualification of those examinations was performed using machined reflectors and other types of simulated flaws. No indications were reported, and the MRP has no information on the reliability of the procedure. Another vendor performed an examination for lack of fusion between the J-groove weld and the nozzle in a foreign PWR plant.

Surface examination of J-groove welds has been performed using liquid penetrant (PT) methods. Experience has shown that PT of Inconel welds can be difficult due to the presence of large numbers of small weld defects. Furthermore, initial PT examinations of the suspected leaking nozzle at Oconee 1 only produced a few code-acceptable spot PT indications. Only upon further surface grinding did the crack that produced the leak become apparent. Given the above results and the lack of existing acceptance criteria, PT of J-groove welds would likely lead to extensive probing and repairs, even in the absence of PWSCC.



**Inspection Capabilities: Supplementary Question 2**

*"Discuss the industry's ability to perform volumetric NDE of multiple PWR's VHPs prior to January 1, 2002. Include in this discussion a realistic estimate of how many units could be so inspected, the time associated with performing this inspection, and any other costs (i.e., dose, outage duration, replacement power, etc.) associated with conducting such an inspection assuming performing it during a scheduled outage during this time frame, or in an unscheduled outage."*

Several vendors are developing techniques, tooling and training of inspection teams to perform volumetric examinations of CRDM nozzles, and three vendors are known to be capable of providing inspection services to US nuclear plants. These vendors were interviewed to obtain information on their capacity and availability to support Fall 2001 inspections. Although all three claim to be developing extensive capacity, the MRP considers that a reasonable estimate is that 3 to 5 units could be examined this fall. This estimate considers the difficulty of fabricating and qualifying tooling, developing procedures, demonstrating techniques, and recruiting, training, and qualifying sufficient inspection personnel.

The availability of repair capability is also an important consideration. Repair capacity is projected to be more limited than inspection capability for Fall 2001 outages. Therefore, inspecting 3 to 5 units this fall appears to be a reasonable estimate of the industry capability.

Qualification of equipment for complete examination of both the nozzle and the J-groove welds is not considered possible for the Fall 2001 outages given the short time available. Therefore, the MRP is focusing attention upon demonstrating the capability to ensure the absence of large ID or OD initiated cracking of the nozzle material on a best effort basis.

The time, cost, dose, outage duration and replacement power costs associated with performing volumetric inspections depend upon plant-specific details. The data in Table 4 provide a rough estimate of what can be expected. The estimates have wide ranges based upon differences in plant design, contamination levels, equipment availability, personnel availability, replacement power costs at the time the work is performed, etc.

It is important to note that no US vendor has performed 100% volumetric examinations to date, so the cost and time estimates listed are uncertain due to the lack of actual experience.

Table 4  
Rough Estimates of Effort to Perform Volumetric or Visual Inspections of Nozzles

Content Deleted –  
EPRI Proprietary Information

**Inspection Capabilities: Supplementary Question 3**

*" Discuss the industry's ability to perform a visual examination of the upper PWR head sufficient to detect evidence of leakage from the VHPs prior to January 1, 2002. Include in this discussion a realistic estimate of how many units could be so inspected, the time associated with performing this inspection, and any other costs (i.e., dose, outage duration, replacement power, etc.) associated with conducting such an inspection assuming performing it during a scheduled outage during this time frame, or in an unscheduled outage."*

As discussed in the response to Section 3.0 Comment 6, seven plants performed visual inspections of the reactor vessel head surface during the Spring 2001 refueling outages. The major factor affecting the effort to perform such an inspection is the design of the insulation and head structure. If the insulation is supported above the head surface, then it may be relatively easy to gain access for direct visual or video probe examinations. However, if the insulation rests on the vessel head, or is cast onto the head or around the nozzles, then gaining access may be significantly more time consuming and costly.

The time, cost, dose, outage duration and replacement power costs associated with performing top of the head inspections depend upon plant specific details. The data in Table 4 above provide a rough estimate of what can be expected. The estimates have wide ranges based upon differences in plant design, head insulation packages, contamination levels, equipment availability, personnel availability, replacement power costs at the time the work is performed, etc.