



# Building a Risk Framework for Spent Fuel Dry Storage System

DSFM REG CON

November 18-19, 2015

Donald Chung, Ph. D.



# NRC Risk-Informed Overarching Goals

- Continue to assure adequate protection of public health and safety, while eliminating unnecessary conservatism in regulatory analyses.
- Enhance safety by focusing resources in areas commensurate with their importance to health and safety.
- Provide appropriate flexibility for licensees.

# Technical Analysis

- NMSS - Analyses tailored to fit problem:
  - 1) Magnitude of hazard,
  - 2) Complexity of the safety issues,
  - 3) Availability of data
- What are we looking at?
  - Engineered casks isolate nuclear material under a variety of normal and off-normal conditions
    - 1) Continue to maintain integrity of engineered storage casks over longer time periods than originally anticipated.
    - 2) Maintain ability to remove fuel without operational safety problems (10CFR 72.122(h)(1))

# Accident Risk

- Accident risk guidelines do not officially exist for NMSS.
- There is no analogs to CDF and LERF for spent fuel dry storage.
- No accident has ever occurred that compromised the integrity of package during dry storage or transportation of spent fuel.

# Implementation Plan for Risk-Informing Regulatory Activities for Dry Cask Storage

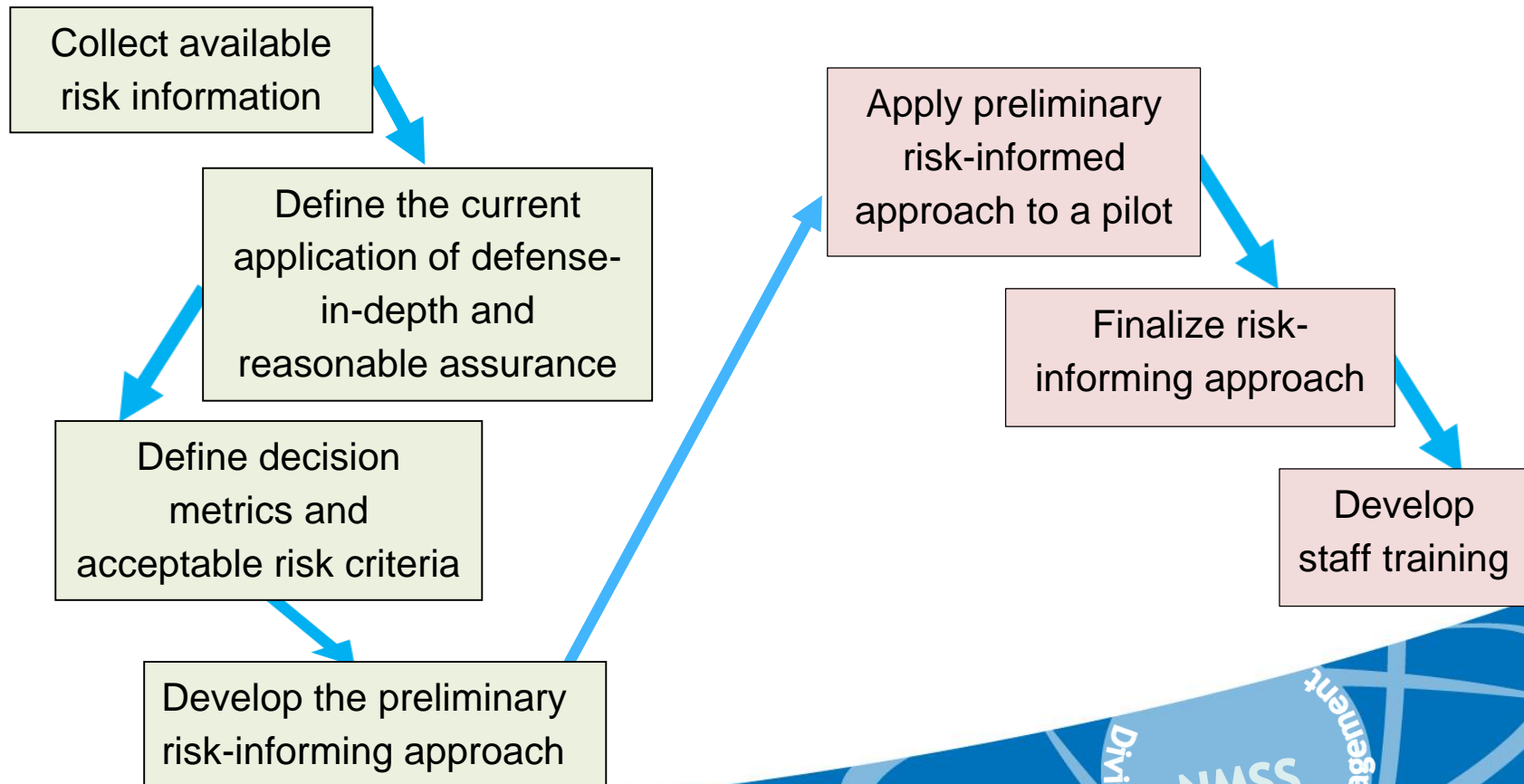

# Available PRAs of Dry Storage

- NUREG-1864, A Pilot Probabilistic Risk Assessment of a Dry Cask Storage System at a Nuclear Power Plant (ML071340012)
- EPRI-1009691, Probabilistic Risk Assessment of Bolted Storage Casks

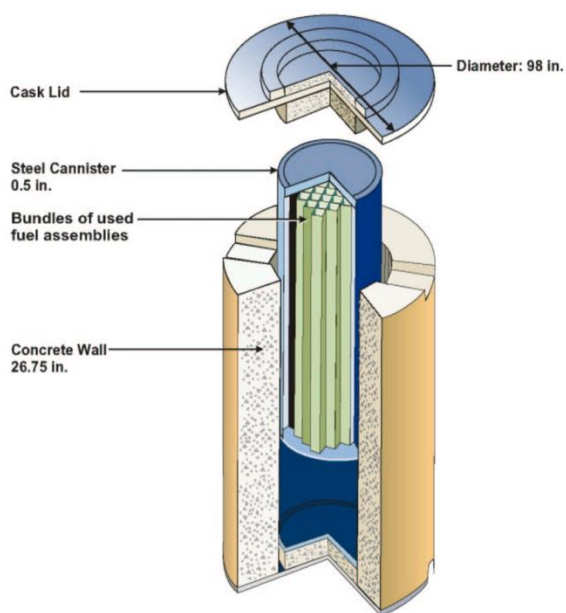

(Holtec International  
HI-STORM 100)

Overall Length: 197 to 225 in.  
Loaded Weight: 360,000 lbs.

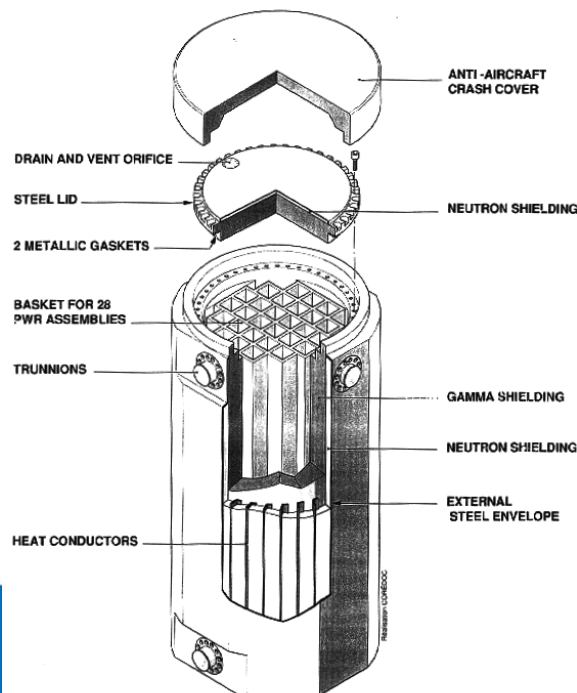

# Three Main Safety Functions in Dry Spent Fuel Storage

Protection  
against release of  
radioactive materials

Safety  
Functions

Protection  
against radiation  
exposure

Protection  
against nuclear  
criticality

# Defining Defense-in-Depth

## Three levels of safety

### Level 1, Prevention

- prevent criticality
- prevent radioactive material release
- limit radiation exposure

### Level 2, Mitigation

- accident assessment
- perform remedial actions
- repair confinement

### Level 3, Emergency Actions

- accident detection/assessment
- notification
- protective response



# Current NMSS Risk Criteria

## Quantitative Health Guidelines (QHG) for NMSS Regulated Facilities

Population at Risk	Risk Metric	Increased Latent Cancer Risk/cask	Risk Limit (BEIR-V)	Regulation
<b>Worker</b>	Annual dose	*1E-05	0.25 mSv (25 mrem)	NMSS (QHG)
<b>Public</b>	Annual dose	*2E-06	0.04 mSv (4 mrem)	NMSS (QHG)

“Risk-Informed Decisionmaking for Nuclear Material and Waste Application”  
 Revision 1, Office of Nuclear Regulatory Research, Office of Nuclear Material  
 Safety and Safeguard, February 2008.

# Latent Cancer Fatality Risk

(A net result of protecting the worker is very low risk to the public)

INDIVIDUAL RISK OF LATENT CANCER FATALITY PER CASK PER YEAR

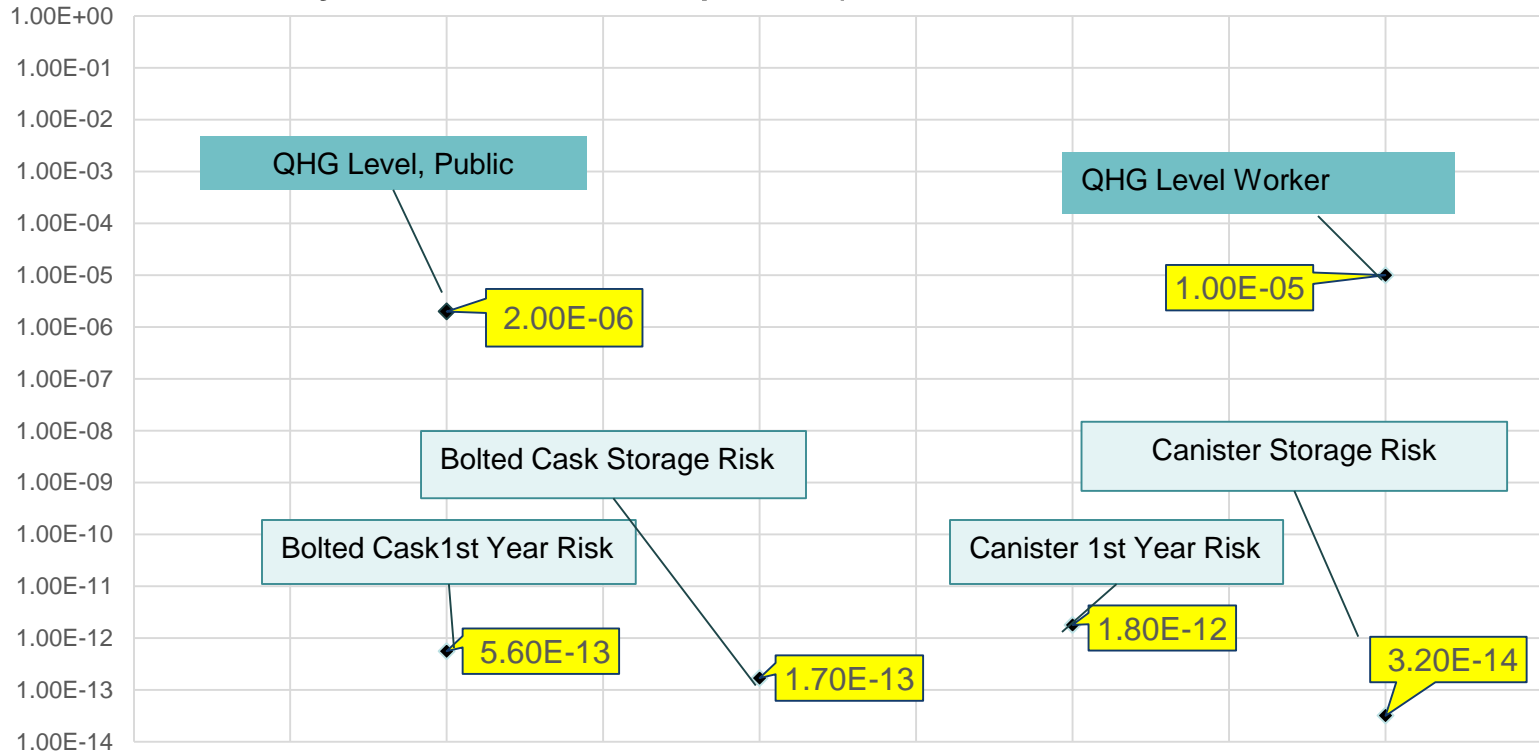

EPRI PRA of Bolted Storage Cask at PWR site

NUREG-1864 PRA of dry cask at a BWR site

# Proposed Regulatory Framework for Dry Spent Fuel Storage

- Adopt Confinement Breach Frequency (CBF) as a surrogate for measurement of risk.
- Set CBF limit for cask preparation. (inside facility)
- Set CBF limit for storage in ISFSI. (outside facility)
- Propose risk-informed regulatory guidance based on CBF limits.

# Confinement Precludes

1. Unacceptable risk of criticality.
2. Unacceptable release of radioactive materials to the environment.
3. Unacceptable radiation dose to the public or workers.
4. Significant impairment of retrievability or recovery of stored nuclear materials.

# Example

## SSC Important to Safety

	Safety Function			Phase of Operation			Defense-in-depth		
	Sub-Criticality	Radiation Protection	Confinement of Material	Loading	Storage (ISFSI)	Unloading	Level 1	Level 2	Level 3
SSC within Scope of License Renewal									
<b>Dry Storage Casks</b>	X	X	X	X	X	X	X		
<b>Spent Fuel Assemblies</b>	X		X	X	X	X	X		
<b>Reinforced Concrete Pads</b>					X		X		
<b>Earthen Berm*</b>		X			X		X	X	

\*Provide protection for nearby population

# Example

## Perform Importance Evaluation

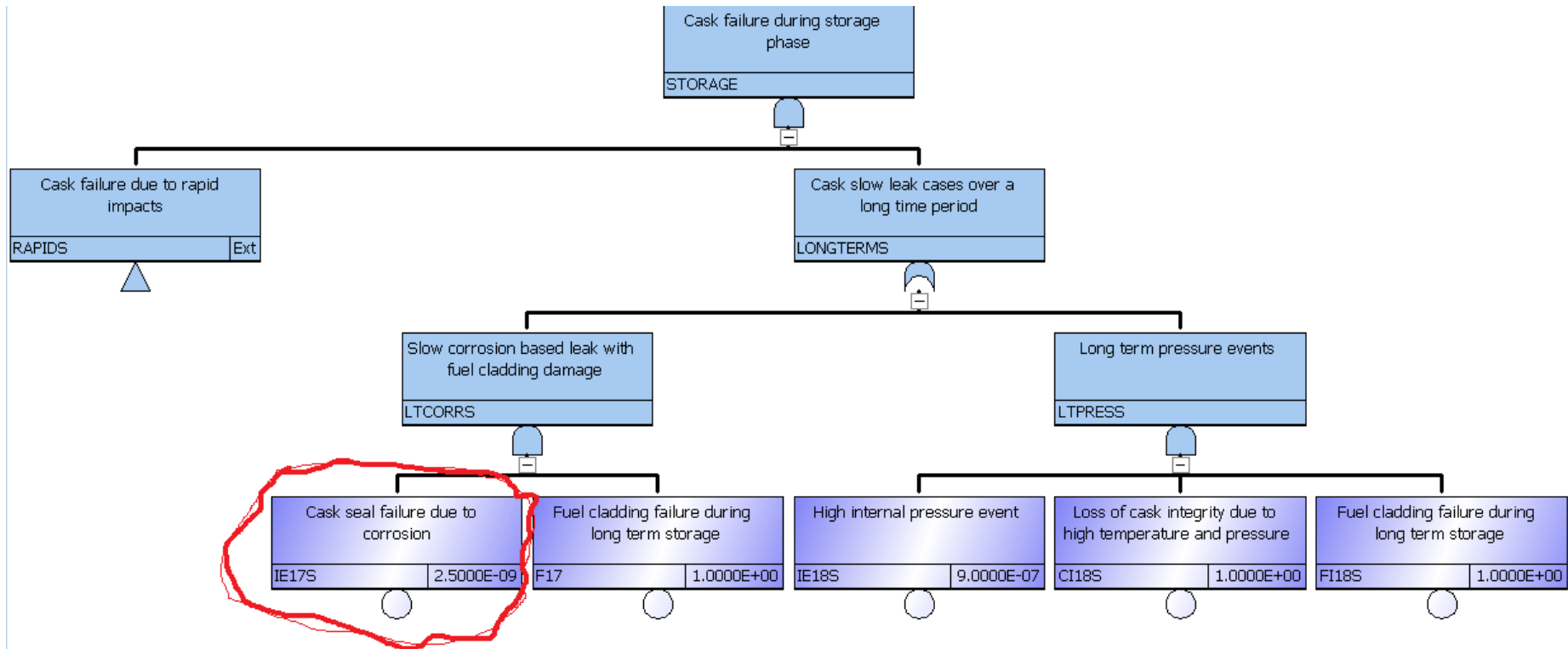

Importance of individual components can be evaluated by setting their failure probability to 1.0, and observing the change in confinement breach probability.

# Example

## Accidental Load Drop During Unloading

What is the increase in risk for storing spent fuel?

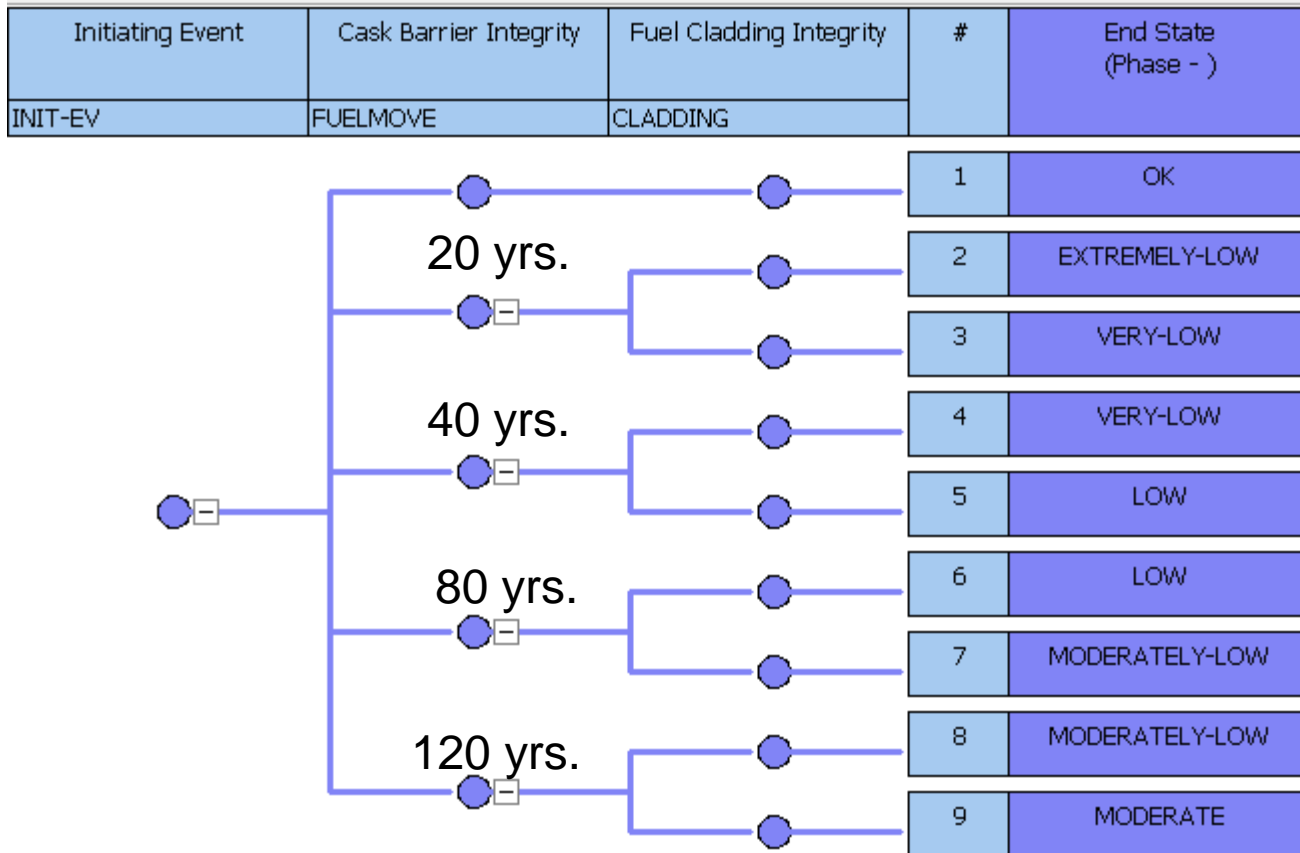

# Potential Applications of Risk Information

## Support Aging Management Review:

- Rank SSCs based on their risk importance
- Possibly modifying monitoring/inspection requirements based on risk.
- Potential for setting license renewal interval based on risk.





# Questions

Donald Chung, PhD  
301 415-8738  
Donald.Chung@nrc.gov

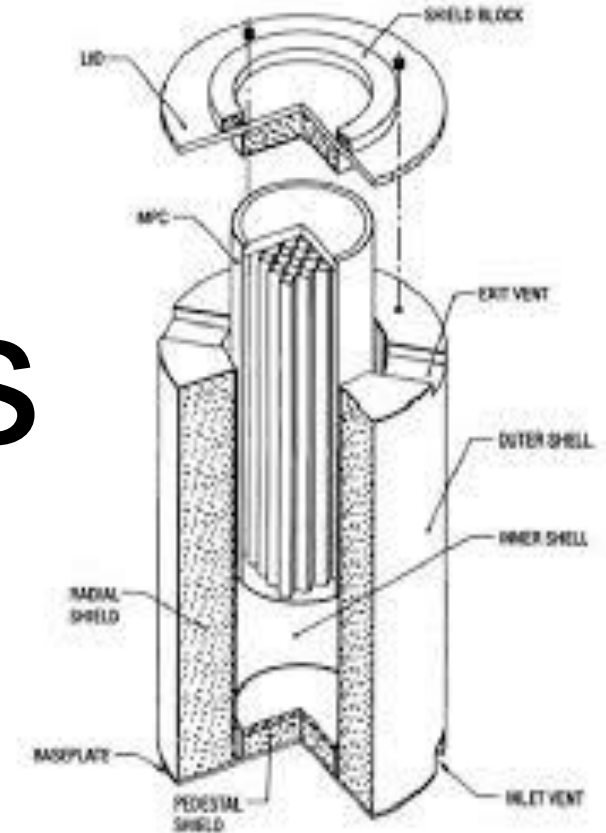

# References

- NUREG-1864, “A Pilot Probabilistic Risk Assessment of a Dry Cask Storage System at a Nuclear Power Plant.” (ML071340012)
- Probabilistic Risk Assessment of Bolted Storage Casks (EPRI-1009691)
- “Risk-Informed Decisionmaking for Nuclear Material and Waste Applications,” Revision 1, February 2008. (ML080720238)
- NUREG-1536, Rev. 1 “Standard Review Plan for Spent Fuel Dry Storage Systems at a General License Facility.” (ML101040620)

# Acronyms and Abbreviations

ALARA – As low as reasonably achievable  
BEIR – Committee on the Biological Effects of Ionizing Radiation  
CBF – Confinement breach frequency  
CDF – Core damage frequency  
EPRI – Electric Power Research Institute  
ISFSI – Independent spent fuel storage installation  
LERF – Large early release frequency  
NRC – US Nuclear Regulatory Commission  
NRR – Office of Nuclear Reactor Regulation  
Mrem - millirem  
MRS – Monitored retrievable storage  
mSv - milliSievert  
NMSS – Office of Nuclear Material Safety and Safeguards  
PRA – Probabilistic Risk Assessment  
QHG – Qualitative Health Guideline  
SSC – Systems, structure, components  
TEDE – Total Effective Dose Equivalent