



Department of Energy

Washington, DC 20585

FEB 1 1993

Mr. Joseph J. Holonich, Director
Repository Licensing and Quality Assurance
Project Directorate
Division of High-Level Waste Management
Office of Nuclear Material Safety
and Safeguards
U.S. Nuclear Regulatory Commission
Washington, DC 20555

Dear Mr. Holonich:

One copy of the enclosed materials was provided to the Center for Nuclear Waste Regulatory Analyses by Dr. Michael A. Duffy at the U.S. Nuclear Regulatory Commission/U.S. Department of Energy Technical Exchange on Overview of Systems Engineering Application to the High-Level Radioactive Waste Repository Program that was held on October 29, 1992, in San Antonio, Texas. This letter transmits additional copies. If you have any questions on the enclosed materials, please contact Priscilla Bunton at (202) 586-8365.

Linda J. Desell, Chief
Regulatory Integration Branch
Office of Civilian Radioactive
Waste Management

100015

Enclosures:

- (1) Physical System Requirements-Transport Waste, April 1992, DOE/RW-0352
- (2) Physical System Requirements-Overall System, January 1992, DOE/RW-0334P
- (3) Physical System Requirements-Dispose of Waste, (draft document) June 21, 1991
- (4) Physical System Requirements-Store Waste, January 1992, DOE/RW-0319
- (5) Physical System Requirements-Accept Waste, August 1992, DOE/RW-0369
- (6) Physical System Requirements-Exploratory Studies Facility, July 1991

9302160136 930204
PDR WASTE
WM-11 PDR

NH03/1
102.2
WM-11

*Rec'd with letter cited
2/4/93*

UNCONTROLLED COPY

Office of Civilian Radioactive Waste Management

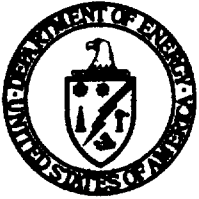

Physical System Requirements – Transport Waste

April 1992

**U.S. Department of Energy
Office of Civilian Radioactive Waste Management**

102.2

~~9206030164~~

ENCLOSURE 1

This is an OCRWM Program-level CONTROLLED DOCUMENT. The holder identified on the title page is responsible for keeping this document current by incorporating all subsequent revisions as they are distributed and for having this document readily available, subject to audit and recall. Controlled copy numbers are assigned to positions, not to individuals. The incumbent of the position to which this document is assigned is responsible for maintaining it. When the incumbent leaves the position, he/she is to return it to the PCCB Executive Secretariat for reissuance to his/her successor.

The Program Change Control Procedure, DOE/RW-0223P, specifies responsibilities of the controlled document holder and instructions for supplemental distribution. The Program-Level Controlled Document Register (updated monthly) identifies the current revision of this document. The Revision/Change Record in the front of this document identifies the pages affected by each revision.

Office of Civilian Radioactive Waste Management



Physical System Requirements – Transport Waste

April 1992

U.S. Department of Energy
Office of Civilian Radioactive Waste Management
Washington, D.C. 20585

Enclosure #1
102.2

**OFFICE OF CIVILIAN RADIOACTIVE WASTE MANAGEMENT
PROGRAM CHANGE CONTROL BOARD
DIRECTIVE**

(1) DCP NUMBER: 59 (2) DCP TITLE: Initial Issuance of Physical System Requirements-Transport Waste

(3) DOCUMENT NUMBER: N/A (4) COGNIZANT ORGANIZATION: RW-321//SEB
 REVISION: N/A
 DOCUMENT TITLE: Physical System Requirements-Transport Waste

(5) DCP DISPOSITION:

<input checked="" type="checkbox"/> APPROVE	<input type="checkbox"/> DISAPPROVE
<input type="checkbox"/> APPROVE WITH CONDITIONS	<input type="checkbox"/> ACTION DEFERRED
	<input type="checkbox"/> CANCELLED/WITHDRAWN

(6) CONDITIONS/RATIONALE:

Per implementation direction of DCP-56 (Interim Approach to the Technical Baseline), the Physical System Requirements-Transport Waste document replaces the applicable portions of both the WMSR, Volume I and the WMSD documents as the technical baseline requirements for the Transportation System.

(7) IMPLEMENTATION DIRECTION:

This document is hereby approved and shall be effective immediately.

(8) CONCURRENCE: _____
 (IF REQUIRED) DIRECTOR, OQA
 DATE: _____

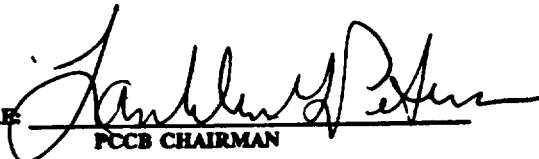
(9) SIGNATURE: 
 PCCB CHAIRMAN
 DATE: 4/10/92

(10) IMPLEMENTATION COMPLETE:

VERIFICATION: _____
 (IF REQUIRED) DIRECTOR, OQA
 DATE: _____

SIGNATURE: _____
 PCCB EXECUTIVE SECRETARY
 DATE: _____

Table of Contents

1.0	INTRODUCTION	1
1.1	Background	1
1.2	Objective	2
1.3	Approach	2
1.4	Mission	5
1.5	Scope	5
2.0	FUNCTIONS AND REQUIREMENTS	9
3.0	ARCHITECTURE DESCRIPTION	134
4.0	INTERFACES	157

APPENDICES

Appendix A	Glossary	178
Appendix B	Bibliography	185
Appendix C	Decision Documentation	189
Appendix D	Acronyms	190
Appendix E	Transport Waste Interfaces	191
Appendix F1	Waste Acceptance Schedule	193
Appendix F2	SNF Characteristics For Design of Transportation System To/From MRS	194
Appendix F3	SNF Transportation Rates To/From MRS By Mode	195
Appendix G	Indentured List of Transport Waste Functions	196

LIST OF TABLES

Table 1.	Source Documents Containing Requirements in this Report	4
Tables F1.-F1.2.3.7.4	Function Descriptions	12
Tables A1.-A1.2.5.9	Architecture Descriptions	136

LIST OF FIGURES

Figure 1	Physical System Functional Analysis Approach	3
Figure 2	Manage Waste Disposal Boundaries	6
Figure 3	Transport Waste Boundaries	7
Figure 4	Transport Waste Function Hierarchy	11
Figure 5	Transport Waste Conceptual Architecture Hierarchy	135
Figures 6-14	N-Square Charts	158
Figures 15-24	Functional Flow Diagrams	167

1.0 INTRODUCTION

1.1 Background

The Nuclear Waste Policy Act (NWPA) of 1982 assigned to the Department of Energy (DOE) the responsibility for managing the disposal of spent nuclear fuel and high-level radioactive waste and established the Office of Civilian Radioactive Waste Management (OCRWM) for that purpose. The Secretary of Energy, in his November 1989 report to Congress (DOE/RW-0247), announced three new initiatives for the conduct of the Civilian Radioactive Waste Management (CRWM) program. One of these initiatives was to establish improved management structure and procedures. In response, OCRWM performed a management study and the Director subsequently issued the Management Systems Improvement Strategy (MSIS) on August 10, 1990, calling for a rigorous implementation of systems engineering principles with a special emphasis on functional analysis.

The functional analysis approach establishes a framework for integrating the program management efforts with the technical requirements analysis into a single, unified, and consistent program. This approach recognizes that just as the facilities and equipment comprising the physical waste management system must perform certain functions, so must certain programmatic and management functions be performed within the program in order to successfully bring the physical system into being.

Thus, two separate but coordinated systems engineering efforts have been undertaken: (1) a functional analysis of the operating phase of the waste management system and; (2) a functional analysis of the program. The physical system functional analysis is intended to:

- Identify the functions that must be performed by the physical system and each of its elements to fulfill the waste disposal mission;
- Identify the corresponding requirements imposed on each of the functions; and
- Identify the conceptual architecture that will be used to satisfy the requirements.

The principal purpose of this requirements document is to present the results that were obtained from the conduct of a physical system functional analysis effort for the Transport Waste mission. The starting point for this functional analysis was the further decomposition of the Transport Waste function from the "Physical System

Requirements - Overall System" document. The Physical System Requirements/Functional Analysis Management Plan defines the criteria and activities for the preparation, review, and approval of this document.

1.2 Objective

The objective of this document is to establish the essential functions, requirements, interfaces, and system architecture for the Transport Waste mission. This document will serve as the baseline and the technical requirements contained herein will be the basis for future stages of design and development of the Waste Transportation System.

1.3 Approach

A comprehensive functional analysis of the physical system begins with a statement of the mission, from which all essential functions that the system must perform are derived. The functional analysis process is sequential. Thus, there are several distinct steps, each containing progressively more detail, and each leading to three important pieces of information:

- Functions,
- Requirements, and
- Architecture.

Functions are simple statements of purpose, defining what the system must do; requirements indicate how well the function must be accomplished; and architecture represents a piece of the actual physical system that satisfies a corresponding requirement. This triad of functions (F), requirements (R), and architecture (A) is needed to completely describe and understand the physical system at each level and to set the stage for the next lower level.

Figure 1 illustrates the sequential F-R-A approach that was implemented by a team of technical experts from across the OCRWM program, in accordance with the Physical System Requirements/Functional Analysis Management Plan. These experts were supported by a regulatory review team who extracted all potentially relevant physical system requirements from the source documents identified in Table 1.

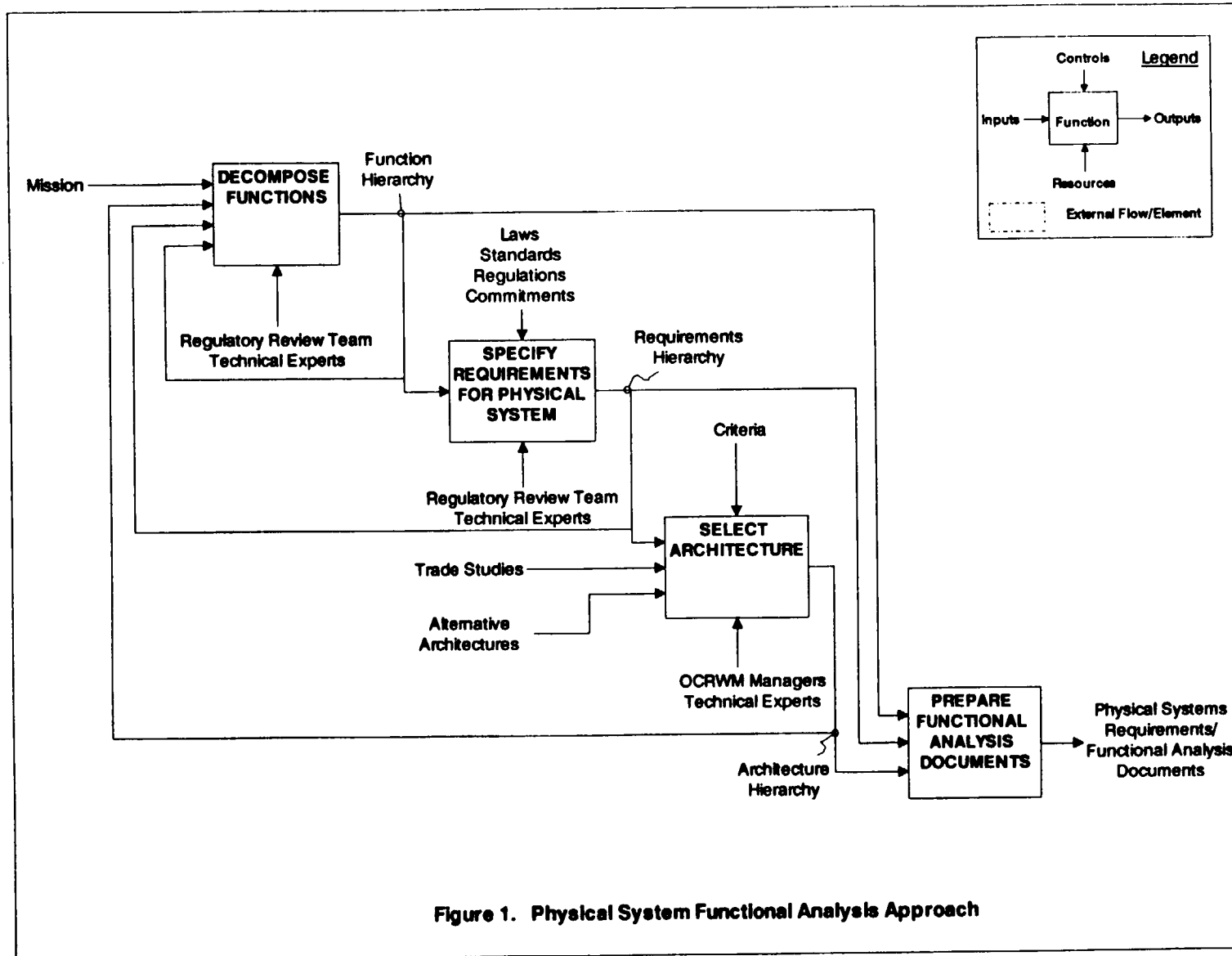

Figure 1. Physical System Functional Analysis Approach

Table 1. Source Documents Containing Requirements in this Transport Waste Document

<u>Document Identifier</u>	<u>Document Description</u>
29 USC 651 et seq.	Occupational Safety and Health Act
NWPA-42 USC 10101 et seq.	Nuclear Waste Policy Act of 1982
10 CFR 20	Standards for Protection Against Radiation ¹
10 CFR 21	Reporting of Defects and Noncompliance ¹
10 CFR 70	Domestic Licensing of Special Nuclear Material
10 CFR 71	Packaging and Transportation of Radioactive Material
10 CFR 73	Physical Protection of Plants and Materials ¹
10 CFR 74	Material Control and Accounting of Special Nuclear Material
10 CFR 961	Standard Contract for Disposal of Spent Nuclear Fuel and/or High-Level Radioactive Waste
49 CFR 171	General Information, Regulations, and Definitions
49 CFR 172	Hazardous Materials Tables, Hazardous Materials Communications Requirements and Emergency Response Information Requirements
49 CFR 173	Shippers - General Requirements for Shipments and Packagings
49 CFR 174	Carriage by Rail
49 CFR 176	Carriage by Vessel
49 CFR 177	Carriage by Public Highway
49 CFR 392	Driving of Motor Vehicles
DOE/RW-0239	The DOE Position on the MRS Facility
DOE ORDER 1540.1	Materials Transportation and Traffic Management
DOE ORDER 5000.3A	Occurrence Reporting and Processing of Operations Information
DOE ORDER 5480.3	Safety Requirements for the Packaging and Transportation of Hazardous Materials, Hazardous Substances, and Hazardous Wastes
DOE ORDER 5480.11	Radiation Protection for Occupational Workers ¹
MOA RW/DP	Memorandum of 7/14/86 on Policy for Shipping Defense High-Level Waste (DHLW) to a Civilian Radioactive Waste Repository
Presidential Memo	Memorandum of 4/30/85 on Disposal of Defense Waste in a Commercial Repository

1. Additional requirements may result from a final document review.

Beginning with the mission statement, the technical experts assigned a set of applicable requirements from those provided by the regulatory review team, and provided an architectural concept. At this point, the mission statement became the parent function which the technical experts decomposed into a set of functions that are both necessary and sufficient to satisfy the parent. Physical system requirements were assigned and architectural concepts provided for each function, establishing the basis for further decomposition. Eventually, a level of detail is reached within the function hierarchy that cannot be supported with either specific requirements or specific architecture. This can lead to some differences in the level of detail for functions, requirements, and architecture contained within this document.

1.4 Mission

Based upon the Nuclear Waste Policy Act, the mission of the Waste Transportation System is to transport SNF and/or HLW from the purchaser's/producer's facilities to, and between, NWMS facilities in a manner that protects the health and safety of the public and of workers and the quality of the environment, makes effective use of financial and other resources, and to the fullest extent possible uses the private sector.

1.5 Scope

1.5.1 Scope of Functional Analysis

The functional analysis process must eventually consider all phases of a system's life cycle. However, it should begin with an analysis of that phase having the greatest impact on the satisfaction of the mission. For the Transport Waste mission, that phase was determined to be the operating phase of the Waste Transportation System. Thus, the time period covered by this functional analysis is from the initial acceptance of spent fuel at the purchaser through the last shipment of waste to the geologic repository.

Figure 2 illustrates the boundaries between the Manage Waste Disposal function and its environment. The environment identified on Figure 2 is defined as anything and everything outside the direct control of the DOE/OCRWM program. The boundaries for the Transport Waste function are shown in Figure 3.

1.5.2 Organization of Document

Section 2.0 of this document contains an explicit description for each of the Transport Waste functions plus the higher level - Manage Waste Disposal function; an identification of the key interfaces (inputs/outputs) between these functions; and a specification of the corresponding requirements (constraints, performance, and interface). All of this information is presented in the form of a single table for each function. The Manage Waste Disposal function (Table F1) is included to provide continuity from the Overall System document and for complete traceability of functions from top to bottom. It should be noted that there may be minor inconsistencies (in functions, requirements, figures, etc.) between the Physical System Requirements documents because the preparation of these documents is an iterative process. Subsequent revision of the Overall System document will incorporate changes from this document and vice versa.

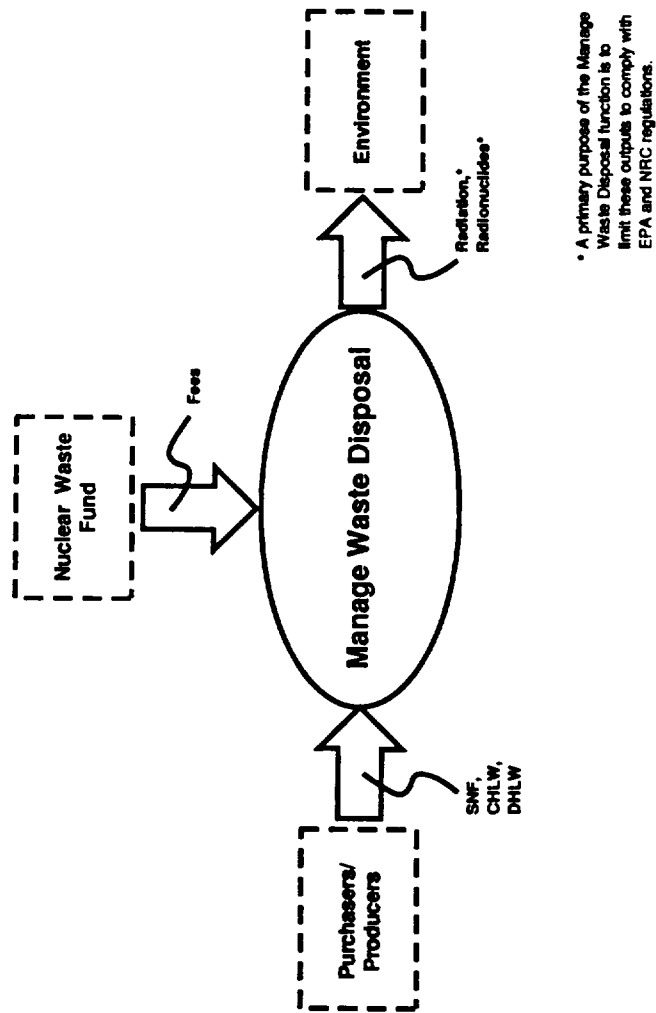

Figure 2. Manage Waste Disposal Boundaries

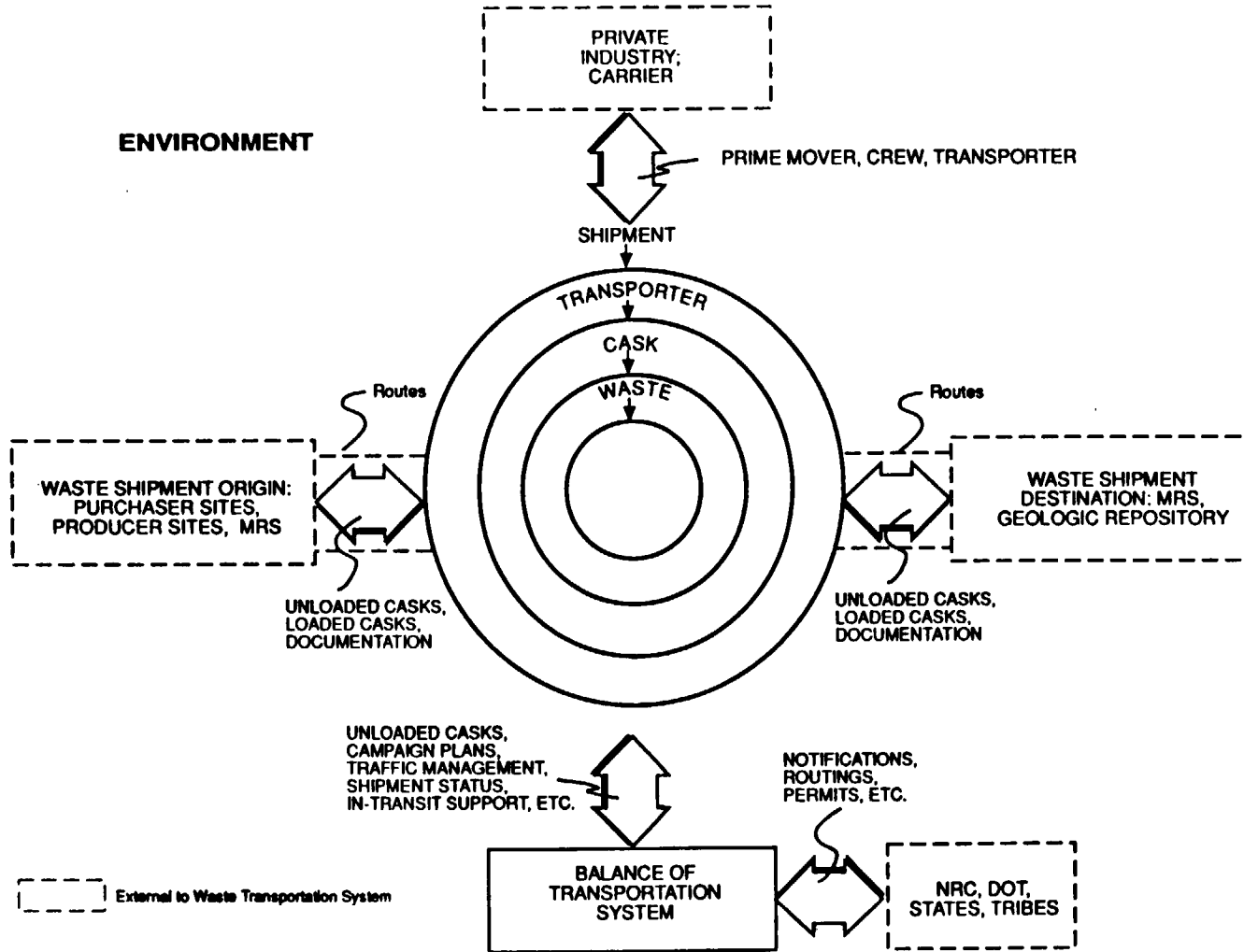

Figure 3. Transport Waste Boundaries

Section 3.0 contains individual architectural description tables for each physical system element of a Waste Transportation System plus the higher level - Nuclear Waste Management System. These tables present the rationale justifying the need for, or the selection of, a particular architecture and a brief description of the concept.

Section 4.0 contains a more illustrative description of the important interfaces that have been identified within the Transport Waste mission. This includes interfaces between the lower level functions and between a function and the external environment. The interfaces at the Manage Waste Disposal level are also included for continuity with the Overall System document. Two types of diagrams are used to illustrate these functional interfaces: N-square charts and functional flow diagrams.

A number of appendices are included in this document. Appendix A is a Glossary of terms that are used throughout the functional analysis effort; Appendix B, a Bibliography of reference documents used in this effort; Appendix C, Decision Documentation, indicates the basis for any DOE/OCRWM decisions that have been made in support of this effort; Appendix D, a list of the Acronyms that are used throughout this document; Appendix E, Transport Waste Interfaces, contains a list of the important inputs and outputs from the Transport Waste function. Other appendices include Appendix F1, Waste Acceptance Schedule; Appendix F2, SNF Characteristics for Design of Transportation System To/From MRS; Appendix F3, SNF Transportation Rates To/From MRS by Mode; and Appendix G, an Indentured List of Transport Waste Functions. In addition, Supplemental Appendices, which are not intended to be approved and controlled, are included as separate attachments for completeness.

2.0 FUNCTIONS AND REQUIREMENTS

Figure 4 displays the functions deemed necessary to fulfill the Transport Waste mission. As indicated, the numbering scheme which uniquely identifies function titles is based on using a 1. at the first level, a 1.2 at the second level, a 1.2.X at the third level, etc. This scheme, which permits traceability between functions and subfunctions, is used throughout the results of the physical system functional analysis. It should be noted that Figure 4 is not consistent with the function hierarchy tree in the Overall System document because the preparation of the Physical System Requirements documents is an iterative process. Subsequent revision of the Overall System document will incorporate changes from this document and vice versa.

Table 1 contains a list of source documents from which the requirements contained in this document were extracted. Although additional source documents have been and will continue to be reviewed, it was determined that the scope and detail contained in the documents referenced in Table 1 are sufficient to specify an initial set of requirements in the Transport Waste requirements document. Other supplementary documents have been identified as potential source documents, which will be reviewed to identify requirements. Any applicable results of these reviews will be incorporated into subsequent revisions to this functional analysis document.

Tables F1. through F1.2.3.7.4 contain descriptions for each of the functions, including an identification of inputs to, and outputs from, each of the functions. A compilation of all inputs and outputs is provided in Appendix E, and an indented list of all Transport Waste functions is provided in Appendix G. Tables F1. through F1.2.3.7.4 also include a compilation of the corresponding requirements that are determined to be appropriate for each function. In general, if a requirement is applicable to all functions at a given level in the hierarchy, it is assigned to their parent function in order to avoid unnecessary repetition. However, interface requirements may be repeated at different function levels to explicitly show the requirements that the inputs to or outputs from the functions should comply with.

Requirements can be one of three types: **constraints**, which are requirements imposed on the function by sources external to OCRWM (e.g., Congress, Environmental Protection Agency, Nuclear Regulatory Commission, other DOE offices); **performance requirements** which are imposed on the function by OCRWM; and **interface requirements** which apply to the inputs to, or outputs from, the functions and may be imposed either by external sources or by OCRWM. The numbering convention used for the identification of requirements in these tables is as follows: for example, 1.2C1: the first constraint (C) assigned to function 1.2; 1.2P1: the first performance requirement (P) assigned to function 1.2; 1.2I1: the only interface requirement assigned to input (I) 1 to function 1.2; and 1.2O1: the only interface requirement assigned to output (O) 1 from function 1.2. Each requirement

that has been extracted from a source document has the appropriate reference noted. Others that have not yet been firmly decided are noted as "None specified at this time". Note that any reference to any term, a table, an appendix, a different section number or paragraph number within a particular requirement statement refers to the term's definition, the table, the appendix, section, or paragraph in the source document itself. Since the preparation of the Physical System Requirements documents is an iterative process certain requirement identification numbers are intentionally left blank. This avoids the possibility of the same requirements having different requirement identification numbers in different Physical System Requirements documents.

OCRWM recognizes that this initial version of the Transport Waste requirements document contains a limited number of performance requirements. Furthermore, many of the interfaces currently have no requirements specified, pending future decisions to be made by OCRWM management on the basis of the results of both prior and future systems studies. Subsequent revisions to this document will include additional specific requirements as they are identified and resolved. To be included, performance and interface requirements tied to quality affecting activities must be (or have been) developed under a Quality Assurance (QA) program which meets the requirements of OCRWM's Quality Assurance Requirements Document, 10 CFR 50 Appendix B, or 10 CFR 71 Subpart H, and NQA-1, and documented under an acceptable decision record format.

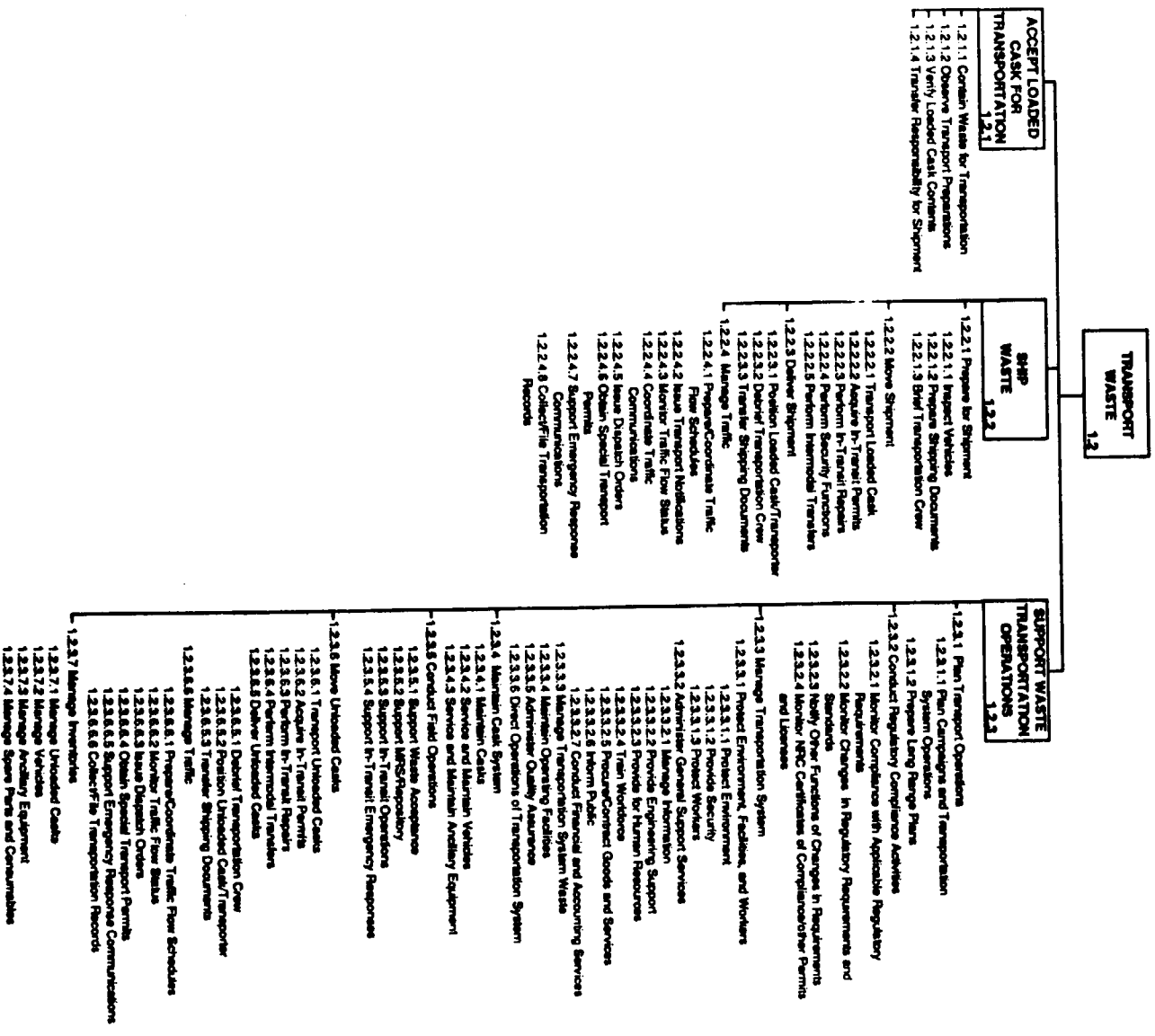

Figure 4. Transport Waste Function Hierarchy

Table F1. Function Description: Manage Waste Disposal

- I. Function ID Number:** 1.
II. Function Title: Manage Waste Disposal
III. Function Definition:

Manage waste disposal means to conduct any physical activity, operation, or process to accept, transport, store, or dispose of spent nuclear fuel or high-level waste.

The mission of the Nuclear Waste Management System (NWMS) is to permanently isolate spent nuclear fuel and high-level radioactive waste in a geologic repository in a timely manner that protects the health and safety of the public and maintains the quality of the environment.

The NWSA defines spent nuclear fuel as the fuel that has been withdrawn from a nuclear reactor following irradiation, the constituent elements of which have not been separated by reprocessing. High-level radioactive waste is defined as (A) the highly radioactive material resulting from the reprocessing of spent nuclear fuel, including liquid waste produced directly in reprocessing and any solid material derived from such liquid waste that contains fission products in sufficient concentrations; and (B) other highly radioactive material that the Commission, consistent with existing law, determines by rule requires permanent isolation. [NWSA Sec. 2 (23) and (12)]

IV. Interfaces:

A. Inputs:

1.11	SNF	From: Purchaser
1.12	CHLW	From: Producer
1.13	DHLW	From: Producer

B. Outputs:

1.O1	Federally-Limited Radiation Exposure	To: Accessible Environment
1.O2	Federally-Limited Release of Radionuclides	To: Accessible Environment

V. Requirements:

A. Constraints:

1.C1 This requirement intentionally left blank.

1.C2 ... the Secretary is authorized to enter into contracts with any person who generates or holds title to high-level radioactive waste, or spent nuclear fuel, of domestic origin for the acceptance of title, subsequent transportation, and disposal of such waste or spent fuel.

[NWSA Sec. 302 (a)(1)]

1.C3 This requirement intentionally left blank.

1.C4 The design objectives for personnel exposure from external sources of radiation in continuously occupied controlled areas are ALARA and not exceeding 0.5 mrem (5 microsieverts) per hour on average. The design objectives for exposure rates for potential exposure to a radiation worker where occupancy is generally not continuous are ALARA and not exceeding 20 percent of the applicable standard in paragraphs 9b(1) and (2).

[DOE ORDER 5480.11(9)(j)(1)(b)]

1.C5 (a) Each employer -

(1) shall furnish to each of his employees employment and a place of employment which are free from recognized hazards that are causing or likely to cause death or serious physical harm to his employees;

(2) shall comply with occupational safety and health standards promulgated under this chapter.

(b) Each employee shall comply with occupational safety and health standards and all rules, regulations, and orders issued pursuant to this chapter which are applicable to his own actions and conduct.

[29 USC 651 et.seq., Sect. 654]

1.C6 d. Procedures.

Program Senior Officials (PSOs) shall take action to have procedures established for implementation of the requirements of this Order for facilities under their cognizance. These procedures shall be approved by the PSO and shall include:

(1) Responsibilities of the contractor, field organization, Headquarters program office, and the HQ Emergency Operations Center (EOC).

(2) Categorization, notification, and reporting requirements for each facility.

e. Training.

PSOs shall take action to have training programs established for both DOE and contractor personnel in the requirements of this Order for facilities under their cognizance. These training programs shall include:

(1) Indoctrination in the philosophy of occurrence reporting as outlined in Paragraph 6 of this Order.

(2) Identification of Reportable Occurrences; their categorization, notification, and associated reporting requirements; analysis, determination of root causes and generic implications; and implementation, tracking and close-out of correction actions.

(3) Utilization of the DOE Operational Data Base, including the input of occurrence reports and obtaining information from the data base.

[DOE Order 5000.3A, 8]

1.C7 RESPONSIBILITIES AND AUTHORITIES

d. Program Senior Officials (PSO), in addition to other responsibilities prescribed in this Order, shall carry out responsibilities which include but are not limited to:

(1) Providing clear and explicit delegations of responsibility and authority for implementing this Order;

(2) Establishing agreements with Heads of Field Organizations to ensure support to the DOE Facility Representative and DOE Program Manager(s) in accordance with this Order;

(3) May appoint Headquarters investigation boards as required under DOE 5484.1.

[DOE Order 5000.3A, 9]

B. Performance:

1.P1 DOE shall accept title to all SNF and/or HLW, of domestic origin, generated by the civilian nuclear power reactor(s) specified in Appendix A, provide subsequent transportation for such material to the DOE facility, and dispose of such material in accordance with the terms of this contract.

[10 CFR 961.11, Article IV, B, 1]

1.P2 This document defines the quality assurance requirements governing activities affecting quality of all affected organizations unless specifically stated otherwise herein. These quality assurance requirements are applicable to the Mined Geologic Disposal System (MGDS), Waste Acceptance Process Activities of High-Level Waste Form Production, Transport of Spent Fuel and High-Level Nuclear Waste, and Monitored Retrievable Storage.

[DOE/RW-0214, p. iii]

C. Interface:

1.I1 Contracts entered into under this section shall provide that-

(A) Following commencement of operation of a repository, the Secretary shall take title to the ... spent nuclear fuel involved as expeditiously as practicable upon the request of the generator or owner of such ... spent fuel; and

(B) in return for the payment of fees established by this section, the Secretary, beginning not later than January 31, 1998, will dispose of the ... spent nuclear fuel involved as provided in this subtitle.

[NWPA Sec. 302 (a)(5)]

1.I2 Contracts entered into under this section shall provide that-

(A) Following commencement of operation of a repository, the Secretary shall take title to the high-level radioactive waste... involved as expeditiously as practicable upon the request of the generator or owner of such waste ... ; and

(B) in return for the payment of fees established by this section, the Secretary, beginning not later than January 31, 1998, will dispose of the high-level radioactive waste ... involved as provided in this subtitle.

[NWPA Sec. 302 (a)(5)]

1.I3 ... the Department of Energy ... plans ... to dispose of defense waste in a commercial repository.

[Presidential Memo, 1985]

1.O1 ... the Federal Government has the responsibility to provide for the permanent disposal of high-level radioactive waste and such spent nuclear fuel as may be disposed of in order to protect the public health and safety and the environment, ...

[NWPA Sec. 111(a)(4)]

1.O2 ... the Federal Government has the responsibility to provide for the permanent disposal of high-level radioactive waste and such spent nuclear fuel as may be disposed of in order to protect the public health and safety and the environment, ...

[NWPA Sec. 111(a)(4)]

Table F1.2 Function Description: Transport Waste

- I. **Function ID Number:** 1.2
- II. **Function Title:** Transport Waste
- III. **Function Definition:**

The acceptance by OCRWM of loaded casks for transport and the movement of loaded and unloaded casks between purchaser/producer sites and DOE NWMS facilities and the movement of loaded and unloaded casks between DOE NWMS facilities.

IV. **Interfaces:**

A. **Inputs:**

- | | | | |
|-------|--|--------------|-------------------|
| 1.2I1 | Loaded SNF Casks/Transporters/Documents | From: | Functions 1.1/1.3 |
| 1.2I2 | Loaded CHLW Casks/Transporters/Documents | From: | Function 1.1 |
| 1.2I3 | Loaded DHLW Casks/Transporters/Documents | From: | Function 1.1 |
| 1.2I4 | Unloaded Casks/Transporters | From: | Functions 1.3/1.4 |

B. **Outputs:**

- | | | | |
|-------|--|------------|------------------------|
| 1.2O1 | Loaded SNF Casks/Transporters | To: | Functions 1.3/1.4 |
| 1.2O2 | Loaded CHLW Casks/Transporters | To: | Function 1.4 |
| 1.2O3 | Loaded DHLW Casks/Transporters | To: | Function 1.4 |
| 1.2O4 | Unloaded Casks/Transporters | To: | Functions 1.1/1.3 |
| 1.2O5 | Federally-Limited Radiation Exposure | To: | Accessible Environment |
| 1.2O6 | Federally-Limited Release of Radionuclides | To: | Accessible Environment |

V. **Requirements:**

A. **Constraints:**

- 1.2C1 This requirement intentionally left blank.
- 1.2C2 This requirement intentionally left blank.
- 1.2C3 This requirement intentionally left blank.
- 1.2C4 This requirement intentionally left blank.
- 1.2C5 Applicability of operating controls and procedures.

A licensee subject to this part, who under a general or specific license transports licensed material or delivers licensed material to a carrier for transport, shall comply with the requirements of this Subpart G, with the quality assurance requirements of Subpart H of this part, and with the general provisions of Subpart A of this part.

[10 CFR 71.81]

- 1.2C6 This requirement intentionally left blank.

1.2C7 **Applicability to Transportation Laws**

Nothing in this Act [42 U.S.C. 10101 et seq.] shall be construed to affect Federal, State, or local laws pertaining to the transportation of spent nuclear fuel or high-level radioactive waste.

[NWPA, Sect. 9]

1.2C8 The Secretary, in providing for the transportation of spent nuclear fuel under this Act [42 U.S.C. 10101 et seq.], shall utilize by contract private industry to the fullest extent possible in each aspect of such transportation. The Secretary shall use direct Federal services for such transportation only upon a determination of the Secretary of Transportation, in consultation with the Secretary, that private industry is unable or unwilling to provide such transportation services at reasonable cost.

[NWPA, Sect. 137(a)(2)]

1.2C9 General License: NRC approved package.

(b) This general license applies only to a licensee who has a quality assurance program approved by the Commission as satisfying the provisions of Subpart H of this part.

(c) This general license applies only to a licensee who:

(1) Has a copy of the specific license, certificate of compliance, or other approval of the package and has the drawings and other documents referenced in the approval relating to the use and maintenance of the packaging and to the actions to be taken prior to shipment;

(2) Complies with the terms and conditions of the license, certificate, or other approval, as applicable, and the applicable requirements of Subparts A, G, and H of this part; and

(3) Submits in writing to the Director, Office of Nuclear Material Safety and Safeguards, U.S. Nuclear Regulatory Commission, Washington, DC 20555, prior to the licensee's first use of the package, the licensee's name and license number and the package identification number specified in the package approval.

[10 CFR 71.12(b)&(c)]

1.2C10 RESPONSIBILITIES AND AUTHORITIES

e. Program Managers, in addition to other responsibilities prescribed in this Order, shall carry out responsibilities which include but are not limited to:

(1) Overseeing activities relating to reportable occurrences including reporting and development of programs and procedures;

(2) Ensuring that a system for prompt notification and categorization of Reportable Occurrences has been established for their DOE programs and for facilities under their cognizance;

(3) Ensuring that the HQ EOC is informed of how they or their designees can be reached at all times;

(4) Ensuring that lessons-learned and generic or programmatic implications are identified and elevated to the PSO for appropriate action;

(5) Ensuring that actions are taken to minimize or prevent recurrence;

(6) Reviewing and assessing Reportable Occurrences information from facilities under the cognizance, to assess significance, root causes, generic implications, and the need for corrective action; and ensuring that DOE and contractor staff involved in these operations perform these functions; and

(7) Ensuring that Occurrence Reports and operations information from other organizations are disseminated to appropriate DOE and contractor activities within their cognizance, are reviewed for generic implications, and are used to improve operations

g. DOE Facility Representatives shall carry out their responsibilities as noted in this Order which include but are not limited to:

-
- (1) Ensuring that contractors under their cognizance prepare and promulgate procedures for notification and reporting that are compatible with and serve the policies of this Order;
 - (2) Concurring in the facility specific procedures and examples of reportable occurrences and categorizations to meet the requirements of this Order;
 - (3) Actively monitoring day-to-day operations and performance of facilities/activities under their cognizance;
 - (4) Ensuring that lessons-learned and generic or programmatic implications are identified and elevated to the Head of the Field Organization for appropriate action;
 - (5) Ensuring that contractor actions are taken to minimize or prevent recurrence;
 - (6) Reviewing and assessing Reportable Occurrences information from facilities under their cognizance, to assess significance, root causes, generic implications, and the need for corrective action, and ensuring that contractor staff involved in these operations perform these functions; and
 - (7) Ensuring that Occurrence Reports and operations information from other organizations are disseminated to appropriate contractor activities within their cognizance, are reviewed for generic implications, and are used to improve operations.

[DOE Order 5000.3A, 9]

1.2C11 No spent nuclear fuel or high-level radioactive waste may be transported by or for the Secretary under subtitle A or under subtitle C except in packages that have been certified for such purpose by the Commission.

[NWPA Sec. 180(a)]

1.2C12 Notification of failure to comply or existence of a defect.

(a) Each individual, corporation, partnership or other entity subject to the regulations in this part shall adopt appropriate procedures to:

(1) Provide for: (i) Evaluating deviations or (ii) informing the licensee or purchaser of the deviation in order that the licensee or purchaser may cause the deviation to be evaluated unless the deviation has been corrected; and

(2) Assure that a director or responsible officer is informed if the construction or operation of a facility, or activity, or a basic component supplied for such facility or activity: (i) Fails to comply with the Atomic Energy Act of 1954, as amended, or any applicable rule, regulation, order or license of the Commission relating to a substantial safety hazard, or (ii) Contains a defect. The effective date of this paragraph has been deferred until January 6, 1978.

(b) (1) A director or responsible officer subject to the regulations of this part or a designated person shall notify the Commission when he obtains information reasonably indicating a failure to comply or a defect affecting (i) the construction or operation of a facility or an activity within the United States that is subject to the licensing requirements under Parts 30, 40, 50, 60, 61, 70, 71, or 72 of this chapter and that is within his organization's responsibility or (ii) a basic component that is within his organization's responsibility and is supplied for a facility or an activity within the United States that is subject to the licensing requirements under Parts 30, 40, 50, 60, 61, 70, 71, or 72 of this chapter. The above notification is not required if such individual has actual knowledge that the Commission has been adequately informed of such defect or such failure to comply.

(2) Initial notification required by this paragraph must be made within 2 days following receipt of the information. Notification must be made to the Director, Office of Nuclear Reactor Regulation, or Director, Office of Nuclear Material Safety and Safeguards, as appropriate, U.S. Nuclear Regulatory Commission,

Washington, DC 20555, or to the Administrator of a Regional Office. If initial notification is by means other than written communication, a written report must be submitted to the appropriate Office within 5 days after the information is obtained. Three copies of each report must be submitted to the Director, Office of Nuclear Reactor Regulation, or Director, Office of Nuclear Material Safety and Safeguards, as appropriate.

(3) The written report required by this paragraph shall include, but need not be limited to, the following information, to the extent known: (i) Name and address of the individual or individuals informing the Commission. (ii) Identification of the facility, the activity, or the basic component supplied for such facility or such activity within the United States which fails to comply or contains a defect. (iii) Identification of the firm constructing the facility or supplying the basic component which fails to comply or contains a defect. (iv) Nature of the defect or failure to comply and the safety hazard which is created or could be created by such defect or failure to comply. (v) The date on which the information of such defect or failure to comply was obtained. (vi) In the case of a basic component which contains a defect or fails to comply, the number and location of all such components in use at, supplied for, or being supplied for one or more facilities or activities subject to the regulations in this part. (vii) The corrective action which has been, is being, or will be taken; the name of the individual organization responsible for the action; and the length of time that has been or will be taken to complete the action. (viii) Any advice related to the defect or failure to comply about the facility, activity, or basic component that has been, is being, or will be given to purchasers or licensees.

(4) The director or responsible officer may authorize an individual to provide the notification required by this paragraph, provided that, this shall not relieve the director or responsible officer of his or her responsibility under this paragraph.

(c) Individuals subject to paragraph (b) of this section may be required by the Commission to supply additional information related to the defect or failure to comply.

[10 CFR 21.21]

1.2C13 Subpart H--Quality Assurance

Quality assurance requirements.

(b) Each licensee shall establish, maintain, and execute a quality assurance program satisfying each of the applicable criteria of Sections 71.101 through 71.137 of this subpart and satisfying any specific provisions that are applicable to the licensee's activities, including procurement of packaging. The licensee shall apply each of the applicable criteria in a graded approach, i.e., to an extent that is consistent with its importance to safety.

[10 CFR 71.101]

B. Performance:

1.2P1 This requirement intentionally left blank.

1.2P2 All shipments from the MRS facility to the repository would be made exclusively by rail in dedicated trains

[DOE/RW-0239, Sec. 3]

C. Interface:

1.2I1 The SNF transportation rate will be in accordance with Appendix F of this document.

[TBD, pending DOE/OCRWM decision]

1.2I2 The CHLW transportation rate will be in accordance with Appendix F of this document.

[TBD, pending DOE/OCRWM decision]

1.2I3 The DHLW transportation rate will be in accordance with Appendix F of this document.

[TBD, pending DOE/OCRWM decision]

1.2I4 No requirements specified at this time

1.2O1 The SNF transportation rate will be in accordance with Appendix F of this document.

[TBD, pending DOE/OCRWM decision]

1.2O2 The CHLW transportation rate will be in accordance with Appendix F of this document.

[TBD, pending DOE/OCRWM decision]

1.2O3 The DHLW transportation rate will be in accordance with Appendix F of this document.

[TBD, pending DOE/OCRWM decision]

1.2O4 DOE shall arrange for, and provide, a cask(s) and all necessary transportation of the SNF and/or HLW from the Purchaser's site to the DOE facility. Such cask(s) shall be furnished sufficiently in advance to accommodate scheduled deliveries. Such cask(s) shall be suitable for use at the Purchaser's site, meet applicable regulatory requirements, and be accompanied by pertinent information including, but not limited to, the following: (a) written procedures for cask handling and loading, including specifications on Purchaser-furnished canisters for containment of failed fuel; (b) Training for Purchaser's personnel in cask handling and loading, as may be necessary; (c) Technical information, special tools, equipment, lifting trunnions, spare parts and consumables needed to use and perform incidental maintenance on the cask(s); and (d) Sufficient documentation on the equipment supplied by DOE.

[10 CFR 961.11, Article IV, B, 2]

1.2O5a A package must be designed and prepared for shipment so that the radiation level does not exceed 200 millirem per hour at any point on the external surface of the package and the transport index does not exceed 10 (See 71.4 "Definitions"). For a package transported as exclusive use by rail, highway, or water, radiation levels external to the package may exceed those limits, but must not exceed any of the following:

(a) 200 millirem/hour on the accessible external surface of the package unless the following conditions are met, in which case the limit is 1000 millirem per hour:

- (1) The shipment is made in a closed transport vehicle;
- (2) Provisions are made to secure the package so that its position within the vehicle remains fixed during transportation; and
- (3) There are no loading or unloading operations between the beginning and end of the transportation;

(b) 200 millirem/hour at any point on the outer surface of the vehicle, including the upper and lower surfaces, or, in the case of an open vehicle, at any point on the vertical planes projected from the outer edges of the vehicle, on the upper surface of the load, and on the lower external surface of the vehicle;

(c) 10 millirem/hour at any point two meters from the vertical planes represented by the outer lateral surfaces of the vehicle, or, in the case of an open vehicle, at any point two meters from the vertical planes projected from the outer edges of the conveyance; and

(d) Two millirem/hour in any normally occupied positions of the vehicle, except that this provision does not apply to private motor carriers when persons occupying these positions are provided with special health supervision, personnel radiation exposure monitoring devices, and training in accordance with 19.12 of this chapter.

[10 CFR 71.47]

1.205b Radiation level limitations.

(a) Except as provided in paragraph (b) of this section, each package of radioactive materials offered for transportation shall be designed and prepared for shipment so that under conditions normally incident to transportation the radiation level does not exceed 200 millirem per hour at any point on the external surface of the package, and the transport index does not exceed 10.

(b) A package which exceeds the radiation level limits specified in paragraph (a) of this section shall be transported by exclusive use shipment only and the radiation levels for such shipment must not exceed the following during transportation:

(1) 200 millirem per hour (2 millisievert per hour) on the external surface of the package unless the following conditions are met, in which case the limit is 1000 millirem per hour (10 millisievert per hour).

(i) The shipment is made in a closed transport vehicle;

(ii) The package is secured within the vehicle so that its position remains fixed during transportation; and

(iii) There are no loading or unloading operations between the beginning and end of the transportation;

(2) 200 millirem per hour (2 millisievert per hour) at any point on the outer surfaces of the vehicle, including the top and underside of the vehicle; or in the case of a flat-bed style vehicle, at any point on the vertical planes projected from the outer edges of the vehicle, on the upper surface of the load (or enclosure is used), and on the lower external surface of the vehicle;

(3) 10 millirem per hour (0.1 millisievert per hour) at any point 2 meters (6.6 feet) from the outer lateral surfaces of the vehicle (excluding the top and underside of the vehicle); or in the case of a flat-bed style vehicle, at any point 2 meters (6.6 feet) from the vertical planes projected by the outer edges of the vehicle (excluding the top and underside of the vehicle); and

(4) 2 millirem per hour (0.02 millisievert per hour) in any normally occupied space, except that this provision does not apply to private carriers if exposed personnel under their control wear radiation dosimetry devices and operate under provisions of a State or Federally regulated radiation protection program.

[49 CFR 173.441]

1.205c Thermal limitations.

Each package of radioactive material shall be designed, constructed, and loaded so that:

(a) The heat generated within the package because of the radioactive contents will not, at any time during transportation, affect the integrity of the package under conditions normally incident to transportation; and

(b) The temperature of the accessible external surfaces of the loaded package will not, assuming still air in the shade at an ambient temperature of 38 deg. C (100 deg. F), exceed either:

- (1) 50 deg.C (122 deg.F) in other than an exclusive use shipment; or
- (2) 82 deg.C (180 deg.F) in an exclusive use shipment.

[49 CFR 173.442]

1.205d Contamination control.

(a) The level of non-fixed (removable) radioactive contamination on the external surfaces of each package offered for shipment shall be kept as low as practicable. The level of non-fixed radioactive contamination may be determined by wiping an area of 300 square centimeters of the surface concerned with an absorbent material, using moderate pressure, and measuring the activity on the wiping material. Sufficient measurements shall be taken in the most appropriate locations to yield a representative assessment of the non-fixed contamination levels. Except as provided in paragraph (b) of this section, the amount of radioactivity measured on any single wiping material when averaged over the surface wiped shall not exceed the limits given in Table 10 at any time during transport. Other methods of assessment of equal or greater efficiency may be used. When other methods are used the detection efficiency of the method used shall be taken into account and in no case shall the non-fixed contamination on the external surfaces of the package exceed ten times the limits listed in Table 10

Table 10 -- Removable External Radioactive Contamination - Wipe Limits

Contaminant	Maximum permissible limits	
	$\mu\text{Ci}/\text{cm}^2$	dpm/cm ²
Beta-gamma emitting radionuclides; all radionuclides with half-lives less than ten days; natural uranium; natural thorium; uranium-235; uranium-238; thorium-232; thorium-228 and thorium-230 when contained in ores or physical concentrates.....	10 ⁻⁵	22
All other alpha emitting radionuclides.....	10 ⁻⁶	2.2

(b) Except as provided in paragraph (d) of this section, in the case of packages transported as exclusive use shipments by rail or public highway only, the removable (non-fixed) radioactive contamination on any package at any time during transport shall not exceed ten times the levels prescribed in paragraph (a) of this section. The levels at the beginning of transport shall not exceed the levels prescribed in paragraph (a) of this section.

(c) Except as provided in paragraph (d) of this section, each transport vehicle used for transporting radioactive materials as an exclusive use shipment which utilizes the provisions of paragraph (b) of this section shall be surveyed with appropriate radiation detection instruments after each use. A vehicle shall not be returned to service until the radiation dose rate at each accessible surface is 0.5 millirem per hour or less, and there is no significant removable (non-fixed) radioactive surface contamination as specified in paragraph (a) of this section.

(d) Paragraph (b) and (c) of this section do not apply to any closed transport vehicle used solely for the transportation by public highway of radioactive material packages with contamination levels that do not exceed 10 times the levels prescribed in paragraph (a) of this section if:

- (1) A survey of the interior surfaces of the empty vehicle shows that the radiation dose rate at any point does not exceed 10 millirem per hour at the surface or 2 millirem per hour at 1 meter (3.3. feet) from the surface;
- (2) Each vehicle is stenciled with the words "For Radioactive Materials Use Only" in letters at least 76 millimeters (3 inches) high in a conspicuous place on both sides of the exterior of the vehicle; and
- (3) Each vehicle is kept closed except for loading or unloading.

[49 CFR 173.443]

1.206 (i)(1) The level of non-fixed (removable) radioactive contamination on the external surfaces of each package offered for shipment is as low as reasonably achievable. The level of non-fixed radioactive contamination may be determined by wiping an area of 300 square centimeters of the surface concerned with an absorbent material, using moderate pressure, and measuring the activity on the wiping material. Sufficient measurements must be taken in the most appropriate locations to yield a representative assessment of the non-fixed contamination levels. Except as provided under paragraph (i)(2) of this section, the amount of radioactivity measured on any single wiping material when averaged over the surface wiped, must not exceed the limits given in Table V of this part at any time during transport. Other methods of assessment of equal or greater efficiency may be used. When other methods are used, the detection efficiency of the method used must be taken into account and in no case may the non-fixed contamination on the external surfaces of the package exceed ten times the limits listed in Table V.

Table V -- Removable External Radioactive Contamination Wipe Limits

Contaminant	Maximum permissible limits	
	$\mu\text{Ci}/\text{cm}^2$	dpm/cm ²
Beta-gamma emitting radionuclides; all radionuclides with half-lives less than ten days; natural uranium; natural thorium; uranium-235; uranium-238; thorium-232; thorium-228 and thorium-230 when contained in ores or physical concentrates.....	10 ⁻⁵	22
All other alpha emitting radionuclides.....	10 ⁻⁶	2.2

(2) In the case of packages transported as exclusive use shipments by rail or highway only, the non-fixed radioactive contamination at any time during transport must not exceed ten times the levels prescribed in paragraph (i)(1) of this section. The levels at the beginning of transport must not exceed the levels prescribed in paragraph (i)(1) of this section;
[10 CFR 71.87]

Table F1.2.1 Function Description: Accept Loaded Cask for Transportation

- I. **Function ID Number:** 1.2.1
- II. **Function Title:** Accept Loaded Cask for Transportation
- III. **Function Definition:**

The acceptance by OCRWM of a loaded cask for transport from the purchaser/producer after the determination that it meets the criteria of 10 CFR 961 or the MOA between EM and OCRWM. The cask is loaded by the purchaser/producer in accordance with the requirements of the cask Certificate of Compliance. OCRWM may observe loading operations, verify the payload characteristics, and loaded cask compliance with the COC and NRC regulations through review of the purchaser/producer documentation. The acceptance of the loaded cask by OCRWM is complete upon signature on the shipment documentation by the designated OCRWM representative.

IV. **Interfaces:**

A. **Inputs:**

1.2.111	Loaded SNF Casks/Transporters	From: Function 1.1 / 1.3
1.2.112	Loaded CHLW Casks/Transporters	From: Function 1.1
1.2.113	Loaded DHLW Casks/Transporters	From: Function 1.1
1.2.114	Information	From: Function 1.1 / 1.3 / Purchaser, Producer
1.2.115	Ancillary Equipment	From: Function 1.2.3

B. Outputs:

1.2.1O1	Loaded SNF Casks/Transporters/ Documents	To:	Function 1.2.2
1.2.1O2	Loaded CHLW Casks/Transporters/ Documents	To:	Function 1.2.2
1.2.1O3	Loaded DHLW Casks/Transporters/ Documents	To:	Function 1.2.2

V. Requirements:

A. Constraints: None specified at this time

B. Performance: None specified at this time

C. Interface:

1.2.1I1a Previously approved Type B package.

(a) A Type B package previously approved by the NRC, but not designated as B(U) or B(M) in the NRC Certificate of Compliance, may be used under the general license of Section 71.12 with the following additional limitations: (1) Fabrication of the packaging was satisfactorily completed before August 31, 1986, as demonstrated by application of its model number in accordance with Section 71.85(c);

[10 CFR 71.13]

1.2.1I1b (a) No person may offer or accept a hazardous material for transportation in commerce unless that material is properly classed, described, packaged, marked, labeled, and in condition for shipment as required or authorized by this subchapter (including Sections 171.11, 171.12, and 176.11), or

(b) No person may transport a hazardous material in commerce unless that material is handled and transported in accordance with this subchapter, or an exemption issued under Subchapter B of this chapter.

[49 CFR 171.2]

1.2.1I2a Same as 1.2.1I1a above.

1.2.1I2b Same as 1.2.1I1b above.

1.2.1I3a Same as 1.2.1I1a above.

1.2.1I3b Same as 1.2.1I1b above.

1.2.1I4 None specified at this time

1.2.1O1 a. Federal Regulations. When offered to the carrier, each shipment of hazardous materials, hazardous substances, or hazardous wastes shall be in compliance with this Order and the applicable safety regulations of the Department of Transportation, and follow the applicable packaging standards of the Nuclear Regulatory Commission (10 CFR 71)

e. Department of Energy as Consignor. When a Department of Energy field organization, rather than a contractor, serves as the actual consignor, independent internal procedures shall be established by the responsible Head of the Field Organization to assure compliance with the standards contained in this Order.

[DOE Order 5480.3, 7]

1.2.102 Same as 1.2.101 above.

1.2.103 Same as 1.2.101 above.

Table F1.2.1.1 Function Description: Contain Waste for Transportation

- I. Function ID Number:** 1.2.1.1
II. Function Title: Contain Waste for Transportation
III. Function Definition:

This function is initiated upon final closure of the cask. The cask must be loaded by the Purchasers/Producers/MRS in accordance with the NRC-issued Certificate of Compliance with respect to the requirements for cask preparation prior to loading, the payload or contents specifications, and the requirements for cask closure and preparation prior to delivery to the carrier. These preparations include certificate-required and regulation-required inspections and tests. Loading and preparation of the cask in accordance with the certificate assures that the cask contents and conditions comply with the assumptions that were the basis for the cask design and the subsequent NRC concurrence that the cask containment system meets the requirements of 10 CFR 71. In addition, certain inspections confirm compliance with regulations related to radiation and contamination limits for the cask. This function is terminated upon opening of the cask, following delivery of the shipment to the DOE facility.

IV. Interfaces:

A. Inputs:

1.2.1.111	Unloaded SNF Casks/Transporters	From: Function 1.1 / 1.3
1.2.1.112	Unloaded CHLW Casks/Transporters	From: Function 1.1
1.2.1.113	Unloaded DHLW Casks/Transporters	From: Function 1.1
1.2.1.114	SNF	From: Function 1.1 / 1.3
1.2.1.115	CHLW	From: Function 1.1
1.2.1.116	DHLW	From: Function 1.1
1.2.1.117	Information	From: Function 1.1 / 1.3 / Purchaser, Producer
1.2.1.118	Ancillary Equipment	From: Function 1.2.3
1.2.1.119	Spare Parts and Consumables	From: Function 1.2.3
1.2.1.110	Shipping Documents	From: Function 1.2.3

B. Outputs:

1.2.1.101	Loaded SNF Casks/Transporters	To: Function 1.1
1.2.1.102	Loaded CHLW Casks/Transporters	To: Function 1.1
1.2.1.103	Loaded DHLW Casks/Transporters	To: Function 1.1
1.2.1.104	Information	To: Function 1.2.1.2
1.2.1.105	Documentation	To: Function 1.1 / 1.2.1.4

V. Requirements:

A. Constraints:

1.2.1.1C1 General License: NRC approved package.

(c) This general license applies only to a licensee who: ...

(2) Complies with the terms and conditions of the license, certificate, or other approval, as applicable, and the applicable requirements of Subparts A, G, and H of this part;

[10 CFR 71.12]

1.2.1.1C2 External Radiation standards for all packages.

A package must be designed and prepared for shipment so that the radiation level does not exceed 200 millirem per hour at any point on the external surface of the package and the transport index does not exceed 10 (See 71.4 "Definitions"). For a package transported as exclusive use by rail, highway, or water, radiation levels external to the package may exceed those limits, but must not exceed any of the following:

(a) 200 millirem/hour on the accessible external surface of the package unless the following conditions are met, in which case the limit is 1000 millirem per hour:

- (1) The shipment is made in a closed transport vehicle;
- (2) Provisions are made to secure the package so that its position within the vehicle remains fixed during transportation; and
- (3) There are no loading or unloading operations between the beginning and end of the transportation;

(b) 200 millirem/hour at any point on the outer surface of the vehicle, including the upper and lower surfaces, or, in the case of an open vehicle, at any point on the vertical planes projected from the outer edges of the vehicle, on the upper surface of the load, and on the lower external surface of the vehicle;

(c) 10 millirem/hour at any point two meters from the vertical planes represented by the outer lateral surfaces of the vehicle, or, in the case of an open vehicle, at any point two meters from the vertical planes projected from the outer edges of the conveyance; and

(d) Two millirem/hour in any normally occupied positions of the vehicle, except that this provision does not apply to private motor carriers when persons occupying these positions are provided with special health supervision, personnel radiation exposure monitoring devices, and training in accordance with 19.12 of this chapter.

[10 CFR 71.47]

1.2.1.1C3 Additional requirements for Type B packages.

(a) A Type B package, in addition to satisfying the requirements of 71.41 through 71.47 must be designed, constructed, and prepared for shipment so that under the tests specified in:

(1) Section 71.71 (Normal Conditions of Transport), there would be no loss or dispersal of radioactive contents, as demonstrated to a sensitivity of 10^{-6} A₂ per hour, no significant increase in external radiation levels, and no substantial reduction in the effectiveness of the packaging; and

(2) Section 71.73 (Hypothetical Accident Conditions), there would be no escape of krypton-85 exceeding 10,000 curies in one week, no escape of other radioactive material exceeding a total amount A₂ in one week, and no external radiation dose rate exceeding one rem per hour at one meter from the external surface of the package.

(b) Compliance with the permitted activity release limits of paragraph (a) of this section must not depend upon filters or upon a mechanical cooling system.

[10 CFR 71.51]

1.2.1.1C4 General requirements for all fissile material packages.

(b) Except as provided in paragraph (c) of this section, a package used for the shipment of fissile material must be so designed and constructed and its contents so limited that it would be subcritical if water were to leak into the containment system or liquid contents were to leak out of the containment system so that, under the following conditions, maximum reactivity of the fissile material would be attained:

-
- (1) The most reactive credible configuration consistent with the chemical and physical form of the material;
 - (2) Moderation by water to the most reactive credible extent; and
 - (3) Close reflection by water on all sides.

(d) A package used for the shipment of fissile material must be so designed and constructed and its contents so limited that under the tests specified in 71.71 (Normal Conditions of Transport):

- (1) The contents would be subcritical;
- (2) The geometric form of the package contents would not be substantially altered;
- (3) There would be no leakage of water into the containment system unless, in the evaluation of undamaged packages under 71.57(a), 71.59(b)(1), and 71.61(a), it has been assumed that moderation is present to such an extent as to cause maximum reactivity consistent with the chemical and physical form of the material; and
- (4) There will be no substantial reduction in the effectiveness of the packaging, including:
 - (i) No more than five percent reduction in the total effective volume of the packaging on which nuclear safety is assessed;
 - (ii) No more than five percent reduction in the effective spacing between the fissile contents and the outer surface of the packaging; and
 - (iii) No occurrence of an aperture in the outer surface of the packaging large enough to permit the entry of a 10 cm (four in.) cube.

(e) A package used for the shipment of fissile material must be so designed and constructed and its contents so limited that under the tests specified in 71.73 (Hypothetical Accident Conditions), the package would be subcritical. For this determination, it must be assumed that:

- (1) The fissile material is in the most reactive credible configuration consistent with the damaged condition of the package and the chemical and physical form of the contents;
- (2) Water moderation occurs to the most reactive credible extent consistent with the damaged condition of the package and the chemical and physical form of the contents; and
- (3) There is reflection by water on all sides, as close as is consistent with the damaged condition of the package.

[10 CFR 71.55]

1.2.1.1C5 (a) Plutonium in excess of 20 curies per package must be shipped as a solid.

(b) Plutonium in excess of 20 curies per package must be packaged in a separate inner container placed within outer packaging that meets the requirements of Subparts E and F for packaging of material in normal form. If the entire package is subjected to the tests specified in 71.71 (Normal Conditions of Transport), the separate inner container must not release plutonium, as demonstrated to a sensitivity of 10^{-6} A₂ per hour. If the entire package is subjected to the tests specified in 71.73 (Hypothetical Accident Conditions), the separate inner container must restrict the loss of plutonium to not more than A₂ in one week. Solid plutonium in the following forms is exempt from the requirements of this paragraph:

- (1) Reactor fuel elements;

(2) Metal or metal alloy; and

(3) Other plutonium bearing solids that the Commission determines should be exempt from the requirements of this section.

[10 CFR 71.63]

1.2.1.1C6 Assumptions as to unknown properties.

When the isotopic abundance, mass, concentration, degree of irradiation, degree of moderation, or other pertinent property of fissile material in any package is not known, the licensee shall package the fissile material as if the unknown properties have credible values that will cause the maximum nuclear reactivity.

[10 CFR 71.83]

1.2.1.1C7 Radiation level limitations.

(a) Except as provided in paragraph (b) of this section, each package of radioactive materials offered for transportation shall be designed and prepared for shipment so that under conditions normally incident to transportation the radiation level does not exceed 200 millirem per hour at any point on the external surface of the package, and the transport index does not exceed 10.

(b) A package which exceeds the radiation level limits specified in paragraph (a) of this section shall be transported by exclusive use shipment only and the radiation levels for such shipment must not exceed the following during transportation:

(1) 200 millirem per hour (2 millisievert per hour) on the external surface of the package unless the following conditions are met, in which case the limit is 1000 millirem per hour (10 millisievert per hour).

(i) The shipment is made in a closed transport vehicle;

(ii) The package is secured within the vehicle so that its position remains fixed during transportation; and

(iii) There are no loading or unloading operations between the beginning and end of the transportation;

(2) 200 millirem per hour (2 millisievert per hour) at any point on the outer surfaces of the vehicle, including the top and underside of the vehicle; or in the case of a flat-bed style vehicle, at any point on the vertical planes projected from the outer edges of the vehicle, on the upper surface of the load (or enclosure is used), and on the lower external surface of the vehicle;

(3) 10 millirem per hour (0.1 millisievert per hour) at any point 2 meters (6.6 feet) from the outer lateral surfaces of the vehicle (excluding the top and underside of the vehicle); or in the case of a flat-bed style vehicle, at any point 2 meters (6.6 feet) from the vertical planes projected by the outer edges of the vehicle (excluding the top and underside of the vehicle); and

(4) 2 millirem per hour (0.02 millisievert per hour) in any normally occupied space, except that this provision does not apply to private carriers if exposed personnel under their control wear radiation dosimetry devices and operate under provisions of a State or Federally regulated radiation protection program.

(c) For shipments made under the provisions of paragraph (b) of this section, the shipper shall provide specific written instructions for maintenance of the exclusive use shipment controls to the carrier. The instructions shall be included with the shipping paper information ...

(e) The written instructions required for exclusive use shipments must be sufficient so that, when followed, they will cause the carrier to avoid actions which will unnecessarily delay delivery or unnecessarily result in increased radiation levels or radiation exposures.

[49 CFR 173.441]

1.2.1.1C8¹ b. Special Packaging Requirements for Plutonium Bearing Wastes (in addition to other packaging requirements in this Order).

(1) Solid plutonium or plutonium bearing wastes in greater than A₂ quantities for normal form or greater than A₁ quantities for special form must be packaged in accordance with a specified DOE Certificate of Compliance, an NRC Certificate of Compliance, a DOT exempt packaging system, or a DOT Specification package

(3) Plutonium packaging requirements for any surface mode of transportation.

(a) Plutonium in excess of 20 curies per package must be shipped as a solid.

(b) Plutonium in excess of 20 curies per package must be packaged in a separate inner container placed within outer packaging that meets the requirements of a Type B package for material in normal form. In addition, the following tests must be performed on the package design:

1. If the entire package is subjected to the design tests specified in paragraph 11, "Normal Conditions of Transport," the separate inner container must restrict the loss of plutonium to no more than 10⁻⁶ A₂/hour.

2. If the entire package is subjected to the design tests specified in paragraph 12, "Hypothetical Accident Conditions," the separate inner container must restrict the loss of plutonium to not more than an A₂ quantity in 1 week.

(4) Solid plutonium in excess of 20 curies per package in the following forms is not subject to the requirements of paragraph 7b(3):

(a) Reactor fuel elements;

(b) Metal or metal alloy;

(c) Special Form materials; or

(d) Other forms of plutonium-bearing materials, e.g., wastes or contaminated equipment, as approved by the Office of Operational Safety.

c. Package Standards for Radioactive Materials in Amounts Greater Than Type A Quantities.

(1) Packages of radioactive materials shall be prepared for shipment and transported in accordance with the provisions of this Order. Department of Transportation specification containers for greater than Type A and fissile materials are considered to meet the standards of this Order and no specific Department of Energy Certificates of Compliance are required for this use when lading meets the specification. Packaging having a current Nuclear Regulatory Commission Certificate of Compliance can be used after the DOE is registered with the Nuclear Regulatory Commission as a user

(4) A quality assurance program must be established and implemented to assure that packages for radioactive materials are fabricated, maintained, and used in accordance with the regulations and approved design features. (Reference 10 CFR 71.37; 10 CFR 71.121; 10 CFR 71.137.)

[DOE Order 5480.3, 7]

B. Performance:

None specified at this time

¹ Note that item b. is in conflict with 10 CFR 71.63 in 1.2.1.1C5.

C. Interface:

1.2.1.111a (a) The smallest overall dimension of a package must not be less than 10 cm (four in.).

(b) The outside of a package must incorporate a feature, such as a seal, which is not readily breakable, and which, while intact, would be evidence that the package has not been opened by unauthorized persons.

(c) Each package must include a containment system securely closed by a positive fastening device which cannot be opened unintentionally.

(d) A package must be of materials and construction which assure that there will be no significant chemical, galvanic, or other reaction among the packaging components or between the packaging components and the package contents, including possible reaction resulting from leakage of water to the maximum credible extent.

(e) A package valve or other device, the failure of which would allow radioactive contents to escape, must be protected against unauthorized operation and, except for a pressure relief device, must be provided with an enclosure to retain any leakage.

(f) A package must be designed, constructed, and prepared for shipment so that under the tests specified in 71.71 (Normal Conditions of Transport) there would be no loss or dispersal of radioactive contents, no significant increase in external radiation levels, and no substantial reduction in the effectiveness of the packaging.

(g) A package must be designed, constructed, and prepared for transport so that in still air at 38°C (100°F) and in the shade, no accessible surface of a package would have a temperature exceeding 50°C (122°F) in a non-exclusive use shipment or 82°C (180°F) in an exclusive use shipment.

(h) A package must not incorporate a feature which is intended to allow continuous venting during transport.

[10 CFR 71.43]

1.2.1.111b (a) Any lifting attachment that is a structural part of a package must be designed with a minimum safety factor of three against yielding when used to lift the package in the intended manner, and must be designed so that failure of any lifting device under excessive load would not impair the ability of the package to meet other requirements of this subpart. Any other structural part of the package which could be used to lift the package must be capable of being rendered inoperable for lifting the package during transport or must be designed with strength equivalent to that required for lifting attachments.

(b) Tie-down devices:

(1) If there is a system of tie-down devices which is a structural part of the package, the system must be capable of withstanding, without generating stress in any material of the package in excess of its yield strength, a static force applied to the center of gravity of the package having a vertical component of two times the weight of the package with its contents, a horizontal component along the direction in which the vehicle travels of 10 times the weight of the package with its contents, and a horizontal component in the transverse direction of five times the weight of the package with its contents.

(2) Any other structural part of the package which could be used to tie down the package must be capable of being rendered inoperable for tying down the package during transport, or must be designed with strength equivalent to that required for tie-down devices.

(3) Each tie-down device which is a structural part of a package must be designed so that failure of the device under excessive load would not impair the ability of the package to meet other requirements of this part.

[10 CFR 71.45]

1.2.1.1I1c Same as 1.2.1.1C3 above.

1.2.1.1I1d Same as 1.2.1.1C4 above.

1.2.1.1I1e Preliminary determinations.

Prior to the first use of any packaging for the shipment of licensed material:

(a) The licensee shall ascertain that there are no cracks, pinholes, uncontrolled voids, or other defects which could significantly reduce the effectiveness of the packaging;

(b) Where the maximum normal operating pressure will exceed 34.3 kilopascal (5 psi) gauge, the licensee shall test the containment system at an internal pressure at least 50% higher than the maximum normal operating pressure to verify the capability of that system to maintain its structural integrity at that pressure.

(c) The licensee shall conspicuously and durably mark the packaging with its model number, gross weight, and a package identification number assigned by the Nuclear Regulatory Commission. Prior to applying the model number, the licensee shall determine that the packaging has been fabricated in accordance with the design approved by the Commission.

[10 CFR 71.85]

1.2.1.1I2a Same as 1.2.1.1I1a above.

1.2.1.1I2b Same as 1.2.1.1I1b above.

1.2.1.1I2c Same as 1.2.1.1C3 above.

1.2.1.1I2d Same as 1.2.1.1C4 above.

1.2.1.1I2e Same as 1.2.1.1I1e above.

1.2.1.1I3a Same as 1.2.1.1I1a above.

1.2.1.1I3b Same as 1.2.1.1I1b above.

1.2.1.1I3c Same as 1.2.1.1C3 above.

1.2.1.1I3d Same as 1.2.1.1C4 above.

1.2.1.1I3e Same as 1.2.1.1I1e above.

1.2.1.1O1a Same as 1.2.1.1C2 above.

1.2.1.1O1b Same as 1.2.1.1C7 above.

1.2.1.1O1c (g) For shipments transported under exclusive use conditions the radiation dose rate must not exceed 2 millirem per hour in any position normally occupied in the motor vehicle. For shipments transported as exclusive use under the provisions of Sec. 173.441(b) for packages with external radiation levels in excess of 200 millirem per hour at the package surface, the motor vehicle must meet the requirements of a closed transport vehicle (Sec. 173.403 of this subchapter).

[49 CFR 177.842]

1.2.1.1O2a Same as 1.2.1.1C2 above.

1.2.1.1O2b Same as 1.2.1.1C7 above.

1.2.1.1O2c Same as 1.2.1.1O1c above.

1.2.1.1O3a Same as 1.2.1.1C2 above.

1.2.1.1O3b Same as 1.2.1.1C7 above.

1.2.1.1O3c Same as 1.2.1.1O1c above.

Table F1.2.1.2 Function Description: Observe Transport Preparations

I. Function ID Number: 1.2.1.2

II. Function Title: Observe Transport Preparations

III. Function Definition:

OCRWM observation of (1) loading the cask, and (2) preparing the loaded cask for shipment. The OCRWM representative shall verify adherence to procedures, completion of checkoff lists, compliance with cask certificate requirements (including monitoring measurements taken during loadings), and verification of results of tests and inspections required by regulations.

IV. Interfaces:

A. Inputs

1.2.1.2I1 Information From: Function 1.2.1.1

B. Outputs:

1.2.1.2O1 Documents, Findings To: Function 1.1 / 1.2.1.3
1.2.1.2O2 Required Repair Findings To: Function 1.2.1.3 / 1.2.3.4

V. Requirements:

A. Constraints: None specified at this time

B. Performance:

1.2.1.2P1 2. Preparation for Transportation.

(a) The Purchaser shall arrange for, and provide, all preparation, packaging, required inspections, and loading activities necessary for the transportation of SNF and/or HLW to the DOE facility. The Purchaser shall notify DOE of such activities sixty (60) days prior to the commencement of such activities. The preparatory activities by the Purchaser shall be made in accordance with all applicable laws and regulations relating to the Purchaser's responsibilities hereunder. DOE may designate a representative to observe the preparatory activities conducted by the Purchaser at the Purchaser's site, and the Purchaser shall afford access to such representative.

[10 CFR 961.11, Article IV, A]

C. Interface: None specified at this time

Table F1.2.1.3 Function Description: Verify Loaded Cask Contents

I. Function ID Number: 1.2.1.3

II. Function Title: Verify Loaded Cask Contents

III. Function Definition:

The physical characteristics and conditions of the loaded cask and its contents shall be verified as within those limiting characteristics specified by the shipping cask Certificate of Compliance specifies. These may include overall length, weight, cross section, active fuel length, enrichment, burn-up, out-of-reactor time, thermal output, cladding conditions, and deformation. Canister characteristics may also be notable. In the case of high-level waste or non-fuel assembly hardware, these characteristics may include source term, thermal output, physical and chemical make-up, and canister configuration. For either payloads, any special sampling requirements would be noted.

Verification of the above characteristics, classifications, and condition of the waste may be accomplished by (1) physical inspection, (2) review of analysis, (3) reliance on certifications made by the waste generator, or (4) any combination of the above.

IV. Interfaces:

A. Inputs

1.2.1.311	Information	From: Purchaser, Producer
1.2.1.312	Documentation	From: Purchaser, Producer
1.2.1.313	Documents, Findings	From: Function 1.2.1.2
1.2.1.314	Required Repair Findings	From: Function 1.2.1.2

B. Outputs:

1.2.1.301	Verified Cask Contents Documents	To: Function 1.2.1.4
-----------	----------------------------------	-----------------------------

V. Requirements:

A. Constraints: None specified at this time

B. Performance:

1.2.1.3P1 Verification of SNF and/or HLW.

During cask loading and prior to acceptance by DOE for transportation to the DOE facility, the SNF and/or HLW description of the shipping lot shall be subject to verification by DOE. To the extent the SNF and/or HLW is consistent with the description submitted and approved, in accordance with Appendices E and F, DOE agrees to accept such SNF and/or HLW for disposal when DOE has verified the SNF and/or HLW description, determined the material is properly loaded, packaged, marked, labeled and ready for transportation, and has taken custody, as evidenced in writing, of the material at the Purchaser's site, f.o.b. carrier. A properly executed off - site radioactive shipment record describing cask contents must be prepared by the Purchaser along with a signed certification which states: "This is to certify that the above-named materials are properly described, classified, packaged, marked and are in proper condition for transfer according to the applicable regulations of the U. S. Department of Transportation."

[10 CFR 961.11, Article VI, B, 2]

C. Interface: None specified at this time

Table F1.2.1.4 Function Description: Transfer Responsibility for Shipment

- I. Function ID Number:** 1.2.1.4
- II. Function Title:** Transfer Responsibility for Shipment
- III. Function Definition:**

OCRWM accepts the loaded casks for transport through acknowledgement that the cask is properly loaded, packaged, marked, labeled and ready for transport by the carrier in compliance with the cask Certificate of Compliance and other regulatory requirements. This acceptance is concurrent with or subsequent to the delivery/transfer of custody of the fuel or HLW from the purchaser to OCRWM. Documentation of cask contents, completion of appropriate loading operations, and results of tests and inspections are reviewed to ensure compliance with requirements. Documentation for each cask shipment is expected to include:

1. Data on cask contents.
2. Radiation readings and smear survey results,
3. Cask loading map,
4. Procedure check-off lists,
5. Results of tests and inspections required by the cask certificate,
6. Results of impact limiter and tie-down inspections,
7. Results of vehicle inspection,
8. Results of other special measurements that may be required,
9. Results of analyses (e.g., source term or thermal analyses that demonstrate that the material shipped is in compliance with cask certificate limitations and/or receiving site limits), and
10. Records of any servicing, maintenance, and repair operations related to the shipment.

Based on satisfactory review results, the OCRWM representative accepts the loaded cask from the purchaser by signature on the appropriate documents.

IV. Interfaces:

A. Inputs:

1.2.1.4I1	Loaded SNF Casks/Transporters	From:	Function 1.1
1.2.1.4I2	Loaded CHLW Casks/Transporters	From:	Function 1.1
1.2.1.4I3	Loaded DHLW Casks/Transporters	From:	Function 1.1
1.2.1.4I4	Verified Waste Description/Documents	From:	Function 1.1
1.2.1.4I5	Documentation	From:	Function 1.1 / 1.2.1.1
1.2.1.4I6	Verified Cask Contents Documents	From:	Function 1.2.1.3

B. Outputs:

1.2.1.4O1	Loaded SNF Casks/Transporters/Documents	To:	Function 1.2.2
1.2.1.4O2	Loaded CHLW Casks/Transporters/Documents	To:	Function 1.2.2
1.2.1.4O3	Loaded DHLW Casks/Transporters/Documents	To:	Function 1.2.2

V. Requirements:

A. Constraints:

1.2.1.4C1 Routine determinations.

Prior to each shipment of licensed material, the licensee shall ensure that the package with its contents satisfies the applicable requirements of this part and of the license. The licensee shall determine that:

- (a) The package is proper for the contents to be shipped;
- (b) The package is in unimpaired physical condition except for superficial defects such as marks or dents;
- (c) Each closure device of the packaging, including any required gasket, is properly installed and secured and free of defects;
- (d) Any system for containing liquid is adequately sealed and has adequate space or other specified provision for expansion of the liquid;
- (e) Any pressure relief device is operable and set in accordance with written procedures;
- (f) The package has been loaded and closed in accordance with written procedures;
- (g) For fissile material, any moderator or neutron absorber, if required, is present and in proper condition;
- (h) Any structural part of the package which could be used to lift or tie down the package during transport is rendered inoperable for that purpose unless it satisfies the design requirements of 71.45;
- (i) (1) The level of non-fixed (removable) radioactive contamination on the external surfaces of each package offered for shipment is as low as reasonably achievable. The level of non-fixed radioactive contamination may be determined by wiping an area of 300 square centimeters of the surface concerned with an absorbent material, using moderate pressure, and measuring the activity on the wiping material. Sufficient measurements must be taken in the most appropriate locations to yield a representative assessment of the non-fixed contamination levels. Except as provided under paragraph (i)(2) of this section, the amount of radioactivity measured on any single wiping material when averaged over the surface wiped, must not exceed the limits given in Table V of this part at any time during transport. Other methods of assessment of equal or greater efficiency may be used. When other methods are used, the detection efficiency of the method used must be taken into account and in no case may the non-fixed contamination on the external surfaces of the package exceed ten times the limits listed in Table V.

Table V -- Removable External Radioactive Contamination Wipe Limits

Contaminant	Maximum permissible limits	
	$\mu\text{Ci}/\text{cm}^2$	dpm/cm ²
Beta-gamma emitting radionuclides; all radionuclides with half-lives less than ten days; natural uranium; natural thorium; uranium-235; uranium-238; thorium-232; thorium-228 and thorium-230 when contained in ores or physical concentrates.....	10 ⁻⁵	22
All other alpha emitting radionuclides.....	10 ⁻⁶	2.2

(2) In the case of packages transported as exclusive use shipments by rail or highway only, the non-fixed radioactive contamination at any time during transport must not exceed ten times the levels prescribed in paragraph (i)(1) of this section. The levels at the beginning of transport must not exceed the levels prescribed in paragraph (i)(1) of this section;

(j) External radiation levels around the package and around the vehicle, if applicable, will not exceed the limits specified in 71.47 at any time during transportation; and

(k) Accessible package surface temperatures will not exceed the limits specified in 71.43(g) at any time during transportation. [10 CFR 71.87]

1.2.1.4C2 Opening instructions.

Prior to delivery of a package to a carrier for transport, the licensee shall ensure that any special instructions needed to safely open the package have been sent to or otherwise made available to the consignee for the consignee's use in accordance with Section 20.205 of this chapter. [10 CFR 71.89]

1.2.1.4C3 OPERATING PROCEDURES

d. Routine Determinations. Prior to each use of a package for shipment of radioactive or fissile materials, the shipper shall ascertain that the package with its contents satisfies the applicable requirements of paragraph 8 including determination that:

- (1) The packaging has not been significantly damaged.
- (2) Any moderators and nonfissile neutron absorbers, if required, are as authorized.
- (3) The closure of the package and any sealing gaskets present are free from defects.
- (4) Any valve through which primary coolant can flow is protected against tampering.
- (5) The internal gauge pressure of the package will not exceed, during the anticipated period of transport, the maximum normal operating pressure.
- (6) Contamination of the primary coolant will not exceed, during the anticipated period of transport, the limits as prescribed in paragraph 8e(1)(d). [DOE Order 5480.3, 10]

² or, for licenses implementing the provisions of 10 CFR 20.1001 - 20.2401, under Section 20.1906.

B. Performance: None specified at this time

C. Interface:

1.2.1.4I1 Same as 1.2.1.4C1 above.

1.2.1.4I2 Same as 1.2.1.4C1 above.

1.2.1.4I3 Same as 1.2.1.4C1 above.

1.2.1.4I4 None specified at this time

1.2.1.4I5 Nuclear material transfer reports.

(a) Each licensee who transfers and each licensee who receives special nuclear material shall complete and distribute a Nuclear Material Transaction Report on DOE/NRC Form 741. This should be done in accordance with the printed instructions for completing the form whenever the licensee transfers or receives a quantity of special nuclear material of 1 gram or more of contained uranium-235, uranium-233, or plutonium.

[10 CFR 74.15]

1.2.1.4O1a Same as 1.2.1.4C2 above.

1.2.1.4O1b Same as 1.2.1.4C3 above.

1.2.1.4O2a Same as 1.2.1.4C2 above.

1.2.1.4O2b Same as 1.2.1.4C3 above.

1.2.1.4O3a Same as 1.2.1.4C2 above.

1.2.1.4O3b Same as 1.2.1.4C3 above.

Table F1.2.2 Function Description: Ship Waste

- I. Function ID Number: 1.2.2
- II. Function Title: Ship Waste
- III. Function Definition:

The loaded cask on the transporter is prepared for shipment (delivery to the carrier) by OCRWM. The loaded cask is then transported from the purchaser/producer to a NWMS site (or between NWMS sites). Delivery to the NWMS site terminates this function. Management of traffic is included in this function.

IV. Interfaces:

A. Inputs:

1.2.2I1	Loaded SNF Casks/Transporters/Documents	From:	Function 1.2.1
1.2.2I2	Loaded CHLW Casks/Transporters/Documents	From:	Function 1.2.1
1.2.2I3	Loaded DHLW Casks/Transporters/Documents	From:	Function 1.2.1

B. Outputs:

1.2.2O1	Loaded SNF Casks/Transporters	To:	Function 1.3 / 1.4
1.2.2O2	Loaded CHLW Casks/Transporters	To:	Function 1.4
1.2.2O3	Loaded DHLW Casks/Transporters	To:	Function 1.4
1.2.2O4	Federally-Limited Radiation Exposure	To:	Accessible Environment
1.2.2O5	Federally-Limited Release of Radionuclides	To:	Accessible Environment

V. Requirements:

A. Constraints:

1.2.2C1 This requirement intentionally left blank.

1.2.2C2 The Secretary shall abide by regulations of the Commission regarding advance notification of State and local governments prior to transportation of spent nuclear fuel or high-level radioactive waste under subtitle A or under subtitle C.

[NWPA Sec. 180(b)]

1.2.2C3 General license to own special nuclear material.

A general license is hereby issued to receive title to and own special nuclear material without regard to quantity. Notwithstanding any other provision of this chapter, a general licensee under this section is not authorized to acquire, deliver, receive, possess, use, transfer, import, or export special nuclear material, except as authorized in a specific license.

[10 CFR 70.20]

1.2.2C4 (a) Each licensee who transports licensed material outside of the confines of its plant or other place of use, or who delivers licensed material to a carrier for transport, shall comply with the applicable requirements of the regulations appropriate to the mode of transport of DOT in 49 CFR Parts 170 through 189.

(1) The licensee shall particularly note DOT regulations in the following areas:

(i) Packaging -- 49 CFR Part 173, Subparts A and B and 173.401 through 173.478.

(ii) Marking and labeling -- 49 CFR Part 172, Subpart D and 172.400 through 172.407; 172.436 through 172.440.

(iii) Placarding -- 49 CFR Part 172.500 through 172.519, 172.556 and Appendices B and C.

(iv) Monitoring -- 49 CFR Part 172, Subpart C.

(v) Accident reporting -- 49 CFR Part 171.15 and 171.16.

(vi) Shipping papers -- 49 CFR Part 172, Subpart C.

(2) The licensee shall also note DOT regulations pertaining to the following modes of transportation:

(i) Rail -- 49 CFR Part 174, Subparts A - D and K ...

(iii) Vessel -- 49 CFR Part 176, Subparts A - D and M.

(iv) Public Highway -- 49 CFR Part 177.

(b) If DOT regulations are not applicable to a shipment of licensed material by rail, highway, or water because the shipment or the transportation of the shipment is not in interstate or foreign commerce, or to a shipment of licensed material by air because the shipment is not transported in civil aircraft, the licensee shall conform to the standards and requirements of the DOT specified in paragraph (a) of this section to the same extent as if the shipment or transportation were in interstate or foreign commerce or in civil aircraft. A request for modification, waiver, or exemption from those requirements, and any notification referred to in those requirements, must be filed with or made to the Director, Office of Nuclear Material Safety and Safeguards, U.S. Nuclear Regulatory Commission, Washington, DC 20555.

[10 CFR 71.5]

1.2.2C5 Applicability.

(a) Description of hazardous materials required. Except as otherwise provided in this subpart, each person who offers a hazardous material for transportation shall describe the hazardous material on the shipping paper in the manner required by this subpart.

[49 CFR 172.200]

1.2.2C6 Inspection

(b) At any point where a train is required to be inspected, each loaded placarded rail car and each rail car immediately adjacent thereto must be inspected. The cars may continue in transit only when the inspection indicates that the cars are in a safe condition for transportation. (See Sections 174.9 and 174.10.) The inspection of a rail car other than a tank car or a rail car containing Division 1.1 or 1.2 (Class A explosive) materials must include a visual inspection for obvious defects of the running gear and any leakage of contents from the car and to determine whether all required placards are in place and conform to the information given on the train consist or other shipping document as required by Sec. 174.26(b).

[49 CFR 174.8]

1.2.2C7 Port security and safety regulations.

(a) Each carrier, master, agent, and charterer of a vessel and all other persons engaged in handling hazardous materials on board vessels shall comply with the applicable provisions of 33 CFR parts 6, 109, 110, 125, 126, and 160.

[49 CFR 176.4]

1.2.2C8 Compliance with Federal Motor Carrier Safety Regulations.

Motor carriers and other persons subject to this part shall comply with 49 CFR Parts 390 through 397 (excluding Sections 397.3 and 397.9) to the extent those rules apply.

[49 CFR 177.804]

1.2.2C9 Routing and training requirements for Class 7 (radioactive) materials.

(a) Except as provided in paragraph (b) of this section, a carrier or any person operating a motor vehicle that contains a Class 7 (radioactive) material for which placarding is required under part 172 of this subchapter shall--

- (1) Ensure that the motor vehicle is operated on routes that minimize radiological risk;
- (2) In determining the level of radiological risk, consider available information on accident rates, transit time, population density and activities, and the time of day and the day of week during which transportation will occur; and
- (3) Tell the driver which route to take and that the motor vehicle contains Class 7 (radioactive) materials.

The requirements of this paragraph do not apply when there is only one practicable highway route available, considering operating necessity and safety, or when the routing of the motor vehicle is subject to paragraph (b) of this section.

[49 CFR 177.825]

1.2.2C10 (b) Except as otherwise permitted in this paragraph and in paragraph (e) of this section, a carrier or any person operating a motor vehicle containing a highway route controlled quantity of Class 7 (radioactive) materials, as defined in Sec. 173.403(l) of this subchapter, shall operate the motor vehicle only over preferred routes. Those routes must be selected by the carrier or that person operating a motor vehicle containing a highway route controlled quantity of radioactive materials to reduce time in transit over the preferred route segment of the trip. An Interstate System bypass or Interstate System beltway around a city, when available, shall be used in place of a preferred route through a city, unless a State routing agency has designated an alternative route.

[49 CFR 177.825]

1.2.2C11 The shipment will be made in full compliance with applicable Federal regulations and in accord with procedures established by RW for spent fuel and defense waste transfer to a repository. All transportation activities pertaining to defense wastes by RW will be coordinated with DOE's Transportation Management Division to ensure as a minimum that the intent of DOE Orders for transportation safety, security, environmental acceptability, and economy are met.

[MOA between DP and RW, 1986]

1.2.2C12 Carriers.

Common and contract carriers, freight forwarders, warehousemen, and the U.S. Postal Service are exempt from the regulations in this part to the extent that they transport special nuclear material in the regular course of carriage for another or storage incident thereto. This exemption does not apply to the storage in transit or transport of material by persons covered by the general license issued under Section 70.20a and Section 70.20b.

[10 CFR 70.12]

1.2.2C13 ... For any shipment of irradiated reactor fuel, the shipper shall provide physical protection in compliance with a plan established under:

- (1) Requirements prescribed by the U.S. Nuclear Regulatory Commission, or
- (2) Equivalent requirements approved by the Director, Office of Hazardous Materials Transportation, RSPA.

[49 CFR 173.22 (c)]

1.2.2C14 A person may transport irradiated reactor fuel only in compliance with a plan if required under Section 173.22(c) of this subchapter that will ensure the physical security of the material. Variation for security purposes from the requirements of this section is permitted so far as necessary to meet the requirements imposed under such a plan, or otherwise imposed by the U.S. Nuclear Regulatory Commission in 10 CFR 73.

[49 CFR 177.825 (e)]

B. Performance: None specified at this time

C. Interface:

1.2.2I1 No spent nuclear fuel or high-level radioactive waste may be transported by or for the Secretary under subtitle A or under subtitle C except in packages that have been certified for such purpose by the Commission.

[NWPA Sec. 180(a)]

1.2.2I2 Same as 1.2.2I1 above.

1.2.2I3 Same as 1.2.2I1 above.

1.2.2O1 None specified at this time

1.2.2O2 None specified at this time

1.2.2O3 None specified at this time

1.2.2O4 None specified at this time

1.2.2O5 None specified at this time

Table F1.2.2.1 Function Description: Prepare for Shipment

I. Function ID Number: 1.2.2.1

II. Function Title: Prepare for Shipment

III. Function Definition:

The carrier inspects the load to ensure compliance with regulatory requirements. The OCRWM representative prepares all documentation, briefs the transporter crew and escorts, and confirms compliance with regulatory requirements. The OCRWM representative certifies the shipment is in proper condition for transportation and provides required documentation to the carrier crew. The carrier acknowledges acceptance of the shipment by signing the bill of lading.

IV. Interfaces:

A. Inputs:

1.2.2.1I1	Loaded SNF Casks/Transporters/Documents	From: Function 1.2.1
1.2.2.1I2	Loaded CHLW Casks/Transporters/Documents	From: Function 1.2.1
1.2.2.1I3	Loaded DHLW Casks/Transporters/Documents	From: Function 1.2.1
1.2.2.1I4	Prime Mover and Crew	From: Function 1.2.3.3.2.5

B. Outputs:

1.2.2.1O1	Loaded SNF Shipment	To: Function 1.2.2.2
1.2.2.1O2	Loaded CHLW Shipment	To: Function 1.2.2.2
1.2.2.1O3	Loaded DHLW Shipment	To: Function 1.2.2.2

V. Requirements:

A. Constraints:

1.2.2.1C1 (d) No person may transport a package of highway route controlled quantity Class 7 (radioactive) materials as defined in Sec. 173.403(1) of this subchapter, on a public highway unless:

(1) The driver has received within the two preceding years, written training on:

(i) Requirements in Parts 172, 173, and 177 of this subchapter pertaining to the Class 7 (radioactive) materials transported;

(ii) The properties and hazards of the Class 7 (radioactive) materials being transported; and

(iii) Procedures to be followed in case of an accident or other emergency.

(2) The driver has in his immediate possession a certificate of training as evidence of training required by this section, and a copy is placed in his qualification file (see Sec. 391.51 of this title), showing:

(i) The driver's name and operator's license number;

(ii) The dates training was provided;

(iii) The name and address of the person providing the training;

(iv) That the driver has been trained in the hazards and characteristics of highway route controlled quantity Class 7 (radioactive) materials; and

(v) A statement by the person providing the training that information on the certificate is accurate.

(3) The driver has in his immediate possession the route plan required by paragraph (c) of this section and operates the motor vehicle in accordance with the route plan. *[49 CFR 177.825]*

B. Performance: None specified at this time

C. Interface:

1.2.2.1I1 None specified at this time

1.2.2.1I2 None specified at this time

1.2.2.1I3 None specified at this time

1.2.2.1I4 Same as 1.2.2.1C1.

1.2.2.1O1 None specified at this time

1.2.2.1O2 None specified at this time

1.2.2.1O3 None specified at this time

Table F1.2.2.1.1 Function Description: Inspect Vehicles

I. Function ID Number: 1.2.2.1.1

II. Function Title: Inspect Vehicles

III. Function Definition:

For truck shipments, the driver connects the tractor to the trailer, and the connection and key pin locking are verified by a second knowledgeable person. The other responsibilities of the driver include the 49 CFR - required inspections, assuring that placarding is correct and visible, raising the trailer's landing gear, removing chocks, and connecting the trailer brake and electric lines. The driver verifies the load is secure, that the communications link and physical security features are operational. Load positioning and attachment, personnel barrier installation, labeling, and placarding are also checked. A survey for loose parts is also completed.

For rail shipments once the cask is loaded onto the railcar and the railcar and cask are in a proper shipping configuration, the cask system may be moved to a staging area. (Most rail shipments are expected to consist of more than one loaded cask. As each cask is loaded, it would be moved from the cask receiving area to the staging area.) The staging area would facilitate the integration of the loaded cask railcar(s) into the train.

Prior to movement, cask loading documentation and the smear and radiation surveys would be completed. Verification of cask tiedown, tamper-indicating seal, and personnel barrier attachments would be completed during mechanical condition walk-around inspection.

The carrier also verifies that all documentation, including permits, emergency action plans, and security information is appropriately carried in the prime mover.

IV. Interfaces:

A. Inputs:

1.2.2.1.1I1	Vehicle	From: Function 1.2.3 / 1.2.3.7.2
1.2.2.1.1I2	Prime Mover and Crew	From: Function 1.2.3.3.6

B. Outputs:

1.2.2.1.1O1	Inspected Vehicle	To: Function 1.2.2.2
1.2.2.1.1O2	Inspected Prime Mover	To: Function 1.2.2.2
1.2.2.1.1O3	Inspection Certification	To: Function 1.2.2.1.2
1.2.2.1.1O4	Vehicle Needing Repair	To: Function 1.2.3.4
1.2.2.1.1O5	Prime Mover Needing Repair	To: Private Transportation Industry

V. Requirements:

A. Constraints:

1.2.2.1.1C1 Subpart A -- General Information and Regulations

Compliance with Federal Motor Carrier Safety Regulations.

Motor carriers and other persons subject to this part shall comply with 49 CFR Parts 390 through 397 (excluding Sections 397.3 and 397.9) to the extent those rules apply.

[49 CFR 177.804]

1.2.2.1.1C2 Equipment inspection and use.

No motor vehicle shall be driven unless the driver thereof shall have satisfied himself that the following parts and accessories are in good working order, nor shall any driver fail to use or make use of such parts and accessories when and as needed:

Service brakes, including trailer brake connections.
Parking (hand) brake.
Steering mechanism.
Lighting devices and reflectors.
Tires.

Horn.
Windshield wiper or wipers.
Rear-vision mirror or mirrors.
Coupling devices.

[49 CFR 392.7]

1.2.2.1.1C3 Emergency equipment, inspection and use.

No motor vehicle shall be driven unless the driver thereof is satisfied that the emergency equipment required by Section 393.95 of this subchapter is in place and ready for use; nor shall any driver fail to use or make use of such equipment when and as needed.

[49 CFR 392.8]

B. Performance: None specified at this time

C. Interface: None specified at this time

Table F1.2.2.1.2 Function Description: Prepare Shipping Documents

I. Function ID Number: 1.2.2.1.2

II. Function Title: Prepare Shipping Documents

III. Function Definition:

The tractor driver, barge captain, or train crew is required to have certain information regarding the material being transported. OCRWM, as the shipper, shall ensure that the following documentation is provided and is in possession of the driver, captain or train crew: (1) a bill of lading (completed as required by the regulations); (2) a route plan (way bill); (3) radiation survey and smear results; (4) an "instructions to driver/engineer" list, which contains emergency response instructions; (5) other important shipment information or data; and (6) any required permits. Other information shall include a cask loading map, escort arrangement information, notifications to be made in the event of an accident, detailed emergency response data, copies of pertinent regulations and cask certifications, vehicle inspection reports, tamper indicating seals. Verification of required contents of the packet shall be supported by a checklist.

IV. Interfaces:

A. Inputs:

1.2.2.1.2I1	Documentation	From: Function 1.1
1.2.2.1.2I2	Inspection Certification	From: Function 1.2.2.1.1

B. Outputs:

1.2.2.1.2O1	Shipping Documents	To: Function 1.2.2.1.3
-------------	--------------------	-------------------------------

V. Requirements:

A. Constraints:

1.2.2.1.2C1 (b) General requirements. To achieve the performance objectives of paragraph (a) of this section, a physical protection system established and maintained, or arranged for, by the licensee shall: ...

(3) Include instructions for each escort and retain a copy of the current instructions as a record for three years after the close of period for which the licensee possesses the special nuclear material under each license that authorizes the activity that requires the

instruction and retain any superseded material for three years after each change. The instructions must direct that, upon detection of the abnormal presence of unauthorized persons, vehicles, or vessels in the vicinity of a spent fuel shipment or upon detection of a deliberately induced situation that has the potential for damaging a spent fuel shipment, the escort will:

- (i) Determine whether or not a threat exists;
 - (ii) Assess the extent of the threat, if any;
 - (iii) Inform local law enforcement agencies of the threat and request assistance;
 - and
 - (iv) Implement the procedures developed in accordance with paragraph (b)(2) of this section.
- [10 CFR 73.37]

1.2.2.1.2C2 Nuclear material transfer reports.

(a) Each licensee who transfers and each licensee who receives special nuclear material shall complete and distribute a Nuclear Material Transaction Report on DOE/NRC Form-741. This should be done in accordance with the printed instructions for completing the form whenever the licensee transfers or receives a quantity of special nuclear material of 1 gram or more of contained uranium-235, uranium-233, or plutonium.

[10 CFR 74.15]

1.2.2.1.2C3 General entries.

(a) Contents. When a description of hazardous material is required to be included on a shipping paper, that description must conform to the following requirements:

(1) When a hazardous material and a material not subject to the requirements of this subchapter are described on the same shipping paper, the hazardous material description entries required by Sec. 172.202 and those additional entries that may be required by Sec. 172.203:

(i) Must be entered first, or

(ii) Must be entered in a color that clearly contrasts with any description on the shipping paper of a material not subject to the requirements of this subchapter, except that a description on a reproduction of a shipping paper may be highlighted, rather than printed, in a contrasting color (the provisions of this paragraph apply only to the basic description required by Sec. 172.202(a) (1) and (2), and (3)), or

(iii) Must be identified by the entry of an "X" placed before the proper shipping name in a column captioned "HM." (The "X" may be replaced by "RQ," if appropriate.)

(2) The required shipping description on a shipping paper and all copies thereof used for transportation purposes, must be legible and printed (manually or mechanically) in English.

(3) Unless it is specifically authorized or required in this subchapter, the required shipping description may not contain any code or abbreviation.

(4) A shipping paper may contain additional information concerning the material provided the information is not inconsistent with the required description. Unless otherwise permitted or required by this subpart, additional information must be placed after the basic description required by Sec. 172.202(a).

(b) Name of shipper. A shipping paper for a shipment by water must contain the name of the shipper.

(c) Continuation page. A shipping paper may consist of more than one page, if each page is consecutively numbered and the first page bears a notation specifying the total number of pages included in the shipping paper. For example, "Page 1 of 4 pages."

(d) Emergency response telephone number. A shipping paper must contain an emergency response telephone number, as prescribed in Subpart G of Part 172 of this subchapter. [49 CFR 172.201]

1.2.2.1.2C4 Description of hazardous material on shipping papers.

(a) The shipping description of a hazardous material on the shipping paper must include:

- (1) The proper shipping name prescribed for the material in Column 2 of the Sec. 172.101 Table;
- (2) The hazard class or division prescribed for the material as shown in Column 3 of the Sec. 172.101 Table (class names, IMO class and division numbers or subsidiary hazard classes may be entered in parentheses following the numerical hazard class);
- (3) The identification number prescribed for the material as shown in Column 4 of the Sec. 172.101 Table; ...
- (5) Except for empty packagings, the total quantity (by weight, volume or as otherwise appropriate) of the hazardous material covered by the description.

(b) Except as provided in this subpart, the basic description specified in paragraphs (a) (1), (2), (3) and (4) of this section must be shown in sequence with no additional information interspersed. For example: "Gasoline, 3, UN 1203, PG II".

(c) The total quantity of the material covered by one description must appear before or after, or both before and after, the description required and authorized by this subpart. The type of packaging and destination marks may be entered in any appropriate manner before or after the basic description. Abbreviations may be used to express units of measurement and types of packagings.

[49 CFR 172.202]

1.2.2.1.2C5 Additional description requirements.

(c) Hazardous substances.

(2) The letters "RQ" shall be entered on the shipping paper either before or after, the basic description required by Sec. 172.202 for each hazardous substance (see definition in 171.8 of this subchapter). For example: "RQ, Allyl alcohol, 3, UN 1098, PG I"; or "Environmentally hazardous substance, solid, n.o.s., 9, UN 3077, PG III, RQ (Adipic acid)".

(d) Radioactive material.

(1) The description for a shipment of radioactive material must include the following additional entries as appropriate:

(i) The name of each radionuclide in the radioactive material that is listed in Sec. 173.435 of this subchapter. Abbreviations, e.g., "99 Mo" are authorized.

(ii) A description of the physical and chemical form of the material, if the material is not in special form (generic chemical description is acceptable for chemical form).

(iii) The activity contained in each package of the shipment in terms of curies, millicuries, or microcuries. Abbreviations are authorized. For the shipment of a package containing a highway route controlled quantity of radioactive materials (see Sec. 173.403(I) of this subchapter), the words "Highway route controlled quantity" must be entered in association with the basic description.

(iv) The category of label applied to each package in the shipment. For example: "RADIOACTIVE WHITE-I."

(v) The transport index assigned to each package in the shipment bearing RADIOACTIVE YELLOW-II or RADIOACTIVE YELLOW-III labels.

(vi) For a shipment of fissile radioactive materials:

(A) The words "Fissile Exempt," if the package is exempt pursuant to Sec. 173.453 of this subchapter, or

(B) If not exempt, the fissile class of each package in the shipment, pursuant to Sec. 173.455 of this subchapter; and

(C) For a Fissile Class III shipment, the additional notation: "Warning--Fissile Class III Shipment. Do not Load More Than * * * Packages per Vehicle." (Asterisks to be replaced by appropriate number.) "In loading and Storage Areas, Keep at Least 20 Feet (6 Meters) from Other Packages Bearing Radioactive Labels."

(D) If a Fissile Class III shipment is to be transported by water, the supplementary notation must also include the following statement: "For shipment by water, only one Fissile Class III shipment is permitted in each hold."

(vii) For a package approved by the U.S. Department of Energy (DOE) or U.S. Nuclear Regulatory Commission (USNRC), a notation of the package identification marking as prescribed in the applicable DOE or USNRC approval. (See Sec. 173.471 of the subchapter.)

(g) Transportation by rail.

(1) The shipping paper for a rail car containing a hazardous material must contain the notation "Placarded" followed by the name of the placard required for the rail car
[49 CFR 172.203]

1.2.2.1.2C6 Shipper's certification.

(a) General. Except as provided in paragraphs (b) and (c) of this section, each person who offers a hazardous material for transportation shall certify that the material is offered for transportation in accordance with this subchapter by printing (manually or mechanically) on the shipping paper containing the required shipping description the certification contained in paragraph (a)(1) of this section or the certification (declaration) containing the language contained in paragraph (a)(2) of this section.

(1) "This is to certify that the above-named materials are properly classified, described, packaged, marked and labeled, and are in proper condition for transportation according to the applicable regulations of the Department of Transportation."

Note: In line one of the certification the words "herein-named" may be substituted for the words "above-named".

(2) "I hereby declare that the contents of this consignment are fully and accurately described above by proper shipping name and are classified, packed, marked and labeled, and are in all respects in proper condition for transport by [*] according to applicable international and national governmental regulations."

*Additional language indicating the modes of transportation to be used may be inserted at this point in the certification. All modes of transportation may be indicated provided that any mode not applicable to a specific shipment is deleted (lined out)

(d) Signature.

The certifications required by paragraph (a) or (c) of this section:

(1) Must be legibly signed by a principal, officer, partner, or employee of the shipper or his agent; and

(2) May be legibly signed manually, by typewriter, or by other mechanical means.
[49 CFR 172.204]

1.2.2.1.2C7 Applicability and general requirements.

(c) General requirements. No person to whom this subpart applies may offer for transportation, accept for transportation, transfer, store or otherwise handle during transportation a hazardous material unless:

- (1) Emergency response information conforming to this subpart is immediately available for use at all times the hazardous material is present; and
- (2) Emergency response information, including the emergency response telephone number, required by this subpart is immediately available to any person who, as a representative of a Federal, state or local government agency, responds to an incident involving a hazardous material, or is conducting an investigation which involves a hazardous material.

[49 CFR 172.600]

1.2.2.1.2C8 Emergency response information.

(a) Information required. For purposes of this subpart, the term "emergency response information" means information that can be used in the mitigation of an incident involving hazardous materials and, as a minimum, must contain the following information:

- (1) The basic description and technical name of the hazardous material as required by Sections 172.202 and 172.203(k), the ICAO Technical Instructions, the IMDG Code, or the TDG Regulations, as appropriate;
- (2) Immediate hazards to health;
- (3) Risks of fire or explosion;
- (4) Immediate precautions to be taken in the event of an accident or incident;
- (5) Immediate methods for handling fires;
- (6) Initial methods for handling spills or leaks in the absence of fire; and
- (7) Preliminary first aid measures.

(b) Form of information. The information required for a hazardous material by paragraph (a) of this section must be:

- (1) Printed legibly in English;
- (2) Available for use away from the package containing the hazardous material; and
- (3) Presented--
 - (i) On a shipping paper;
 - (ii) In a document, other than a shipping paper, that includes both the basic description and technical name of the hazardous material as required by Sections 172.202 and 172.203(k), the ICAO Technical Instructions, the IMDG Code, or the TDG Regulations, as appropriate, and the emergency response information required (e.g., a material safety data sheet); or
 - (iii) Related to the information on a shipping paper, a written notification to pilot-in-command, or a dangerous cargo manifest, in a separate document (e.g., an emergency response guidance document), in a manner that cross-references the description of the hazardous material on the shipping paper with the emergency response information contained in the document. Aboard aircraft, the ICAO "Emergency Response Guidance for Aircraft Incidents Involving Dangerous Goods" and, aboard vessels, the IMO "Emergency Procedures for Ships Carrying Dangerous Goods," or equivalent documents, may be used to satisfy the requirements of this section for a separate document.

[49 CFR 172.602]

1.2.2.1.2C9 Emergency response information.

(c) Maintenance of information. Emergency response information shall be maintained as follows:

(1) Carriers. Each carrier who transports a hazardous material shall maintain the information specified in paragraph (a) of this section in the same manner as prescribed for shipping papers, except that the information must be maintained in the same manner aboard aircraft as the notification to pilot-in-command, and aboard vessels in the same manner as the dangerous cargo manifest. This information must be immediately accessible to train crew personnel, drivers of motor vehicles, flight crew members, and bridge personnel on vessels for use in the event of incidents involving hazardous materials.
[49 CFR 172.602]

1.2.2.1.2C10 Emergency response telephone number.

(a) A person who offers a hazardous material for transportation must provide a 24-hour emergency response telephone number (including the area code or international access code) for use in the event of an emergency involving the hazardous material. The telephone number must be--

- (1) Monitored at all times the hazardous material is in transportation, including storage incidental to transportation;
- (2) The number of a person who is either knowledgeable of the hazards and characteristics of the hazardous material being shipped and has comprehensive emergency response and incident mitigation information for that material, or has immediate access to a person who possesses such knowledge and information; and
- (3) Entered on a shipping paper, as follows:
 - (i) Immediately following the description of the hazardous material required by Subpart C of this Part 172; or
 - (ii) Entered once on the shipping paper in a clearly visible location. This provision may be used only if the telephone number applies to each hazardous material entered on the shipping paper, and if it is indicated that the telephone number is for emergency response information (for example: "EMERGENCY CONTACT: ***").

(b) The telephone number required by paragraph (a) of this section must be the number of the person offering the hazardous material for transportation or the number of an agency or organization capable of, and accepting responsibility for, providing the detailed information concerning the hazardous material. A person offering a hazardous material for transportation who lists the telephone number of an agency or organization shall ensure that agency or organization has received current information on the material, as required by paragraph (a)(2) of this section before it is offered for transportation.

[49 CFR 172.604]

1.2.2.1.2C11 (c) A member of the train crew of a train transporting hazardous materials must have in his possession a copy of the shipping papers for the shipment of hazardous materials being transported showing the information required by Sections 172.202 and 172.203 of this subchapter.
[49 CFR 174.26]

1.2.2.1.2C12 Additional information on waybills, switching orders and other billings.

(a) Each waybill, switching ticket, switching order or other billing used in place thereof, prepared by the carrier from bills-of-lading, shipping orders or other shipping papers, and each shipping order used as a waybill for a rail car required to be placarded by Subpart F of Part 172 of this subchapter must, in addition to containing the information required by Sections 172.202 and 172.203 of this subchapter, be plainly marked by the carrier with:

- (1) In the case of a flatcar carrying trailers or containers, an indication of which trailers or containers contain the hazardous materials; and

(2) The placard endorsement specified in the following table for the hazardous material or class concerned near the space on the face of the billing provided for the car number:

(i) In letters not less than 9 mm (0.4 inch), or

(ii) In bold, uppercase letters not less than .25 cm (0.98 inch) high inside a rectangle made with any symbol such as asterisk (*), dollar sign (\$), capital (X), or the symbol for number (Z).

Class/Division	Placard notation	Placard endorsement
----------------	------------------	---------------------

Class 7	Placarded RADIOACTIVE	Radioactive material.
---------	-----------------------	-----------------------

(b) When the initial movement of a loaded rail car required to be placarded is a switching operation, the switching order, switching receipt, or switching ticket, and all copies thereof, prepared by the shipper, or by the carrier under the shipper's written authority, must contain the following:

(1) The shipping description consisting of:

(i) The proper shipping name specified for the material in Sec. 172.101 or Sec. 172.102 (when authorized) of this subchapter;

(ii) The hazardous class specified for the material in the same Table;

(iii) The identification number (preceded by "UN" or "NA" as appropriate) prescribed for the material in the same Table; and

(iv) The total quantity (by weight, volume, or as otherwise appropriate) of the hazardous material covered by the description.

(2) Except when a certified bill of lading is tendered to the carrier, the shipper's certification and signature specified in Sec. 172.204 of this subchapter.

(3) The placard notation specified in the Table in Sec. 174.25(a).

(4) For any entry for a material that is a hazardous substance, the letters "RQ" entered either before or after the basic description.

[49 CFR 174.25]

1.2.2.1.2C13 Lost or destroyed labels and placards.

Each carrier shall maintain an adequate supply of the labels and placards specified in Subparts E and F of Part 172 of this subchapter on hand to replace those that become lost or destroyed. The carrier shall replace each lost or destroyed label or placard, as the case may be, based on the information on the shipping papers.

[49 CFR 174.33]

1.2.2.1.2C14 Dangerous cargo manifest.

(a) The carrier, its agents, and any person designated for this purpose by the carrier or agents shall prepare a dangerous cargo manifest, list, or stowage plan. This document may not include a material which is not subject to the requirements of 49 CFR or the IMDG Code. This document must be kept in a designated holder on or near the vessel's bridge. It must contain the following information:

(1) Name of vessel and official number. (If the vessel has no official number, the international radio call sign must be substituted.);

(2) Nationality of vessel;

(3) Shipping name and identification number of each hazardous material on board as listed in Sec. 172.101 of this subchapter or as listed in the IMDG Code and an emergency response telephone number as prescribed in subpart G of part 172 of this subchapter.

-
- (4) The number and description of packages (barrels, drums, cylinders, boxes, etc.) and gross weight for each type of packaging;
 - (5) Classification of the hazardous material in accordance with either;
 - (i) The Hazardous Materials Table, Sec. 172.101 of this subchapter; or
 - (ii) The International Maritime Organization's IMDG Code.
 - (6) Any additional description required by Sec. 172.203 of this subchapter.
 - (7) Stowage location of the hazardous material on board the vessel.
 - (8) In the case of a vessel used for the storage of explosives or other hazardous materials, the following additional information is required:
 - (i) Name and address of vessel's owner;
 - (ii) Location of vessel's mooring;
 - (iii) Name of person in charge of vessel;
 - (iv) Name and address of the owner of the cargo; and
 - (v) A complete record, by time intervals of one week, of all receipts and disbursements of hazardous materials. The name and address of the consignor must be shown against all receipts and the name and address of the consignee against all deliveries.

(b) The hazardous material information on the dangerous cargo manifest must be the same as the information furnished by the shipper on the shipping order or other shipping paper, except that the IMO "correct technical name" and the IMO class may be indicated on the manifest as provided in paragraphs (a)(3) and (a)(5) of this section. The person who supervises the preparation of the manifest, list, or stowage plan shall ensure that the information is correctly transcribed, and shall certify to the truth and accuracy of this information to the best of his knowledge and belief by his signature and notation of the date prepared.

(c) The carrier and its agents shall insure that the master, or a licensed deck officer designated by the master and attached to the vessel, or in the case of a barge, the person in charge of the barge, acknowledges the correctness of the dangerous cargo manifest, list or stowage plan by his signature.

(d) For barges, manned or unmanned, the requirements of this section apply except for the following:

(1) In the case of a manned barge, the person in charge of the barge shall prepare the dangerous cargo manifest.

(2) In the case of an unmanned barge, the person responsible for loading the barge is responsible for the preparation of a dangerous cargo manifest, list, or stowage plan and must designate an individual for that purpose.

(3) For all barges, manned or unmanned, the dangerous cargo manifest must be on board the barge in a readily accessible location and a copy must be furnished to the person in charge of the towing vessel.

[49 CFR 176.30]

1.2.2.1.2C15 Labels.

Each carrier shall maintain an adequate supply of the labels required in Subpart E of Part 172 of this subchapter to replace those that become lost or detached. Replacement must be based on information taken from the shipping order, delivery receipt, or other shipping paper covering the shipment.

[49 CFR 176.33]

1.2.2.1.2C16 General stowage requirements

(d) For a shipment of radioactive materials requiring supplemental operational procedures, the shipper must furnish the master or person in charge of the vessel a copy of the necessary operational instructions.

[49 CFR 176.700]

1.2.2.1.2C17 Lost or destroyed labels.

Each carrier shall maintain an adequate supply of the labels specified in Subpart E of Part 172 of this subchapter to replace those that become lost or destroyed. The carrier shall replace each lost or destroyed label based on the information on the shipping papers.

[49 CFR 177.815]

1.2.2.1.2C18 Shipping papers.

(a) General requirements. A carrier may not transport a hazardous material unless it is accompanied by a shipping paper that is prepared in accordance with Sections 172.200, 172.201, 172.202, and 172.203 of this subchapter.

(b) Shipper certification. An initial carrier may not accept a hazardous material offered for transportation unless the shipping paper describing the material includes a shipper's certification which meets the requirements in Sec. 172.204 of this subchapter. Except for a hazardous waste, the certification is not required for shipments to be transported entirely by private carriage and for bulk shipments to be transported in a cargo tank supplied by the carrier.

(c) Requirements when interlining with carriers by rail. A motor carrier shall mark on the shipping paper required by this section, if it offers or delivers a freight container or transport vehicle to a rail carrier for further transportation;

(1) A description of the freight container or transport vehicle; and

(2) The kind of placard affixed to the freight container or transport vehicle.

[49 CFR 177.817]

1.2.2.1.2C19 (c) A carrier (or his agent) who operates a motor vehicle which contains a package of highway route controlled quantity Class 7 (radioactive) materials as defined in Sec. 173.403(I) of this subchapter shall prepare a written route plan and supply a copy before departure to the motor vehicle driver and a copy to the shipper (before departure for exclusive use shipments, or otherwise within fifteen working days following departure). Any variation between the route plan and routes actually used, and the reason for it, shall be reported in an amendment to the route plan delivered to the shipper as soon as practicable but within 30 days following the deviation. The route plan shall contain:

(1) A statement of the origin and destination points, a route selected in compliance with this section, all planned stops, and estimated departure and arrival times; and

(2) Telephone numbers which will access emergency assistance in each State to be entered.

[49 CFR 177.825]

1.2.2.1.2C20 CONSIGNMENT OF SHIPMENTS. Commercial bills of lading, air bills, and other commercial documents covering shipments made by or to Department contractors shall provide for consignment of the shipments from or to either the United States Department of Energy "in care of" the Department's contractor or the Department' contractor "for the United States Department of Energy."

[DOE Order 1540.1, CH-1.5]

1.2.2.1.2C21 PREMIUM TRANSPORTATION.

b. Exclusive use of a vehicle shall be requested only when justified--for security safeguards, or programmatic reasons, because of the nature of the commodity being shipped, or because of a provision in the Certificate of Compliance, the Department of Transportation exemption, or other applicable regulations. Freight bills, or bills, of lading covering such shipments, shall be annotated to indicate both that exclusive use of vehicle was requested and was furnished by the carrier.
[DOE Order 1540.1, CH-1,8]

B. Performance: None specified at this time

C. Interface: None specified at this time

Table F1.2.2.1.3 Function Description: Brief Transportation Crew

I. Function ID Number: 1.2.2.1.3

II. Function Title: Brief Transportation Crew

III. Function Definition:

A predispatch briefing of the carrier crew shall be conducted to ensure that each crew understands the nature of the cargo and is familiar with emergency response actions, the route plan, and physical security procedures. The crew credentials may also be reviewed at this time, if not done earlier.

Credentials include pertinent operator licenses, training certifications and hours-of-service logbook.

The briefing includes a review of the checklist of all compliance items, closure of any open items from previous functions, a review of all documentation related to the shipment including the results of vehicle inspections. At the completion of the briefing, the shipment is ready for movement, the bill of lading is signed by the OCRWM representative and the shipment is accepted by the carrier.

The origin state may initiate a vehicle inspection. Arrangements for the inspection are the responsibility of DOE. Any record of the vehicle inspection would become a part of the shipping documentation because such inspections may be a part of a broad national program for verification of vehicle road-worthiness.

The shipment is considered ready for interstate commerce when the bill of lading is signed by the shipper and accepted by the carrier.

IV. Interfaces:

A. Inputs:

1.2.2.1.3I1 Shipping Documents **From:** Function 1.2.2.1.2

B. Outputs:

1.2.2.1.3O1 Shipping Documents **To:** Function 1.2.2.3 / 1.2.2.3.3

V. Requirements:

A. Constraints:

1.2.2.1.3C1 (b) General requirements. To achieve the performance objectives of paragraph (a) of this section, a physical protection system established and maintained, or arranged for, by the licensee shall: ...

(3) Include instructions for each escort and retain a copy of the current instructions as a record for three years after the close of period for which the licensee possesses the special nuclear material under each license that authorizes the activity that requires the instruction and retain any superseded material for three years after each change. The instructions must direct that, upon detection of the abnormal presence of unauthorized persons, vehicles, or vessels in the vicinity of a spent fuel shipment or upon detection of a deliberately induced situation that has the potential for damaging a spent fuel shipment, the escort will:

- (i) Determine whether or not a threat exists;
- (ii) Assess the extent of the threat, if any;
- (iii) Inform local law enforcement agencies of the threat and request assistance; and
- (iv) Implement the procedures developed in accordance with paragraph (b)(2) of this section.

[10 CFR 73.37]

1.2.2.1.3C2 (5) The transport vehicle driver has been familiarized with, and is capable of implementing, transport vehicle immobilization, communications, and other security procedures. [10 CFR 73.37(c)]

1.2.2.1.3C3 (d) No person may transport a package of highway route controlled quantity Class 7 (radioactive) materials as defined in Sec. 173.403(f) of this subchapter, on a public highway unless:

- (1) The driver has received within the two preceding years, written training on:
 - (i) Requirements in Parts 172, 173, and 177 of this subchapter pertaining to the Class 7 (radioactive) materials transported;
 - (ii) The properties and hazards of the Class 7 (radioactive) materials being transported; and
 - (iii) Procedures to be followed in case of an accident or other emergency.

(2) The driver has in his immediate possession a certificate of training as evidence of training required by this section, and a copy is placed in his qualification file (see Sec. 391.51 of this title), showing:

- (i) The driver's name and operator's license number;
- (ii) The dates training was provided;
- (iii) The name and address of the person providing the training;
- (iv) That the driver has been trained in the hazards and characteristics of highway route controlled quantity Class 7 (radioactive) materials; and
- (v) A statement by the person providing the training that information on the certificate is accurate.

(3) The driver has in his immediate possession the route plan required by paragraph (c) of this section and operates the motor vehicle in accordance with the route plan. [49 CFR 177.825]

B. Performance: None specified at this time

C. Interface: None specified at this time

Table F1.2.2.2 Function Description: Move Shipment

I. Function ID Number: 1.2.2.2

II. Function Title: Move Shipment

III. Function Definition:

The spent fuel or high-level waste is moved over a designated route from the purchaser/producer's site to the NWMS facility (or between NWMS facilities) following acceptance of the shipment by the carrier. Movement is by road, rail, or barge and includes any necessary intermodal transfers of the loaded cask. Included in this function are the acquisition of any required in-transit permits and special arrangements by the carrier, the performance of in-transit repairs, and the performance of in-transit security functions. This function concludes upon acceptance of the loaded cask by the NWMS facility.

IV. Interfaces:

A. Inputs:

1.2.2.2I1	Loaded SNF Shipment	From: Function 1.2.2.1
1.2.2.2I2	Loaded CHLW Shipment	From: Function 1.2.2.1
1.2.2.2I3	Loaded DHLW Shipment	From: Function 1.2.2.1

B. Outputs:

1.2.2.2O1	Loaded SNF Shipment	To: Function 1.2.2.3
1.2.2.2O2	Loaded CHLW Shipment	To: Function 1.2.2.3
1.2.2.2O3	Loaded DHLW Shipment	To: Function 1.2.2.3
1.2.2.2O4	Shipment Status Information	To: Function 1.2.2.4

V. Requirements:

A. Constraints: None specified at this time

B. Performance: None specified at this time

C. Interface: None specified at this time

Table F1.2.2.1 Function Description: Transport Loaded Cask

I. Function ID Number: 1.2.2.1

II. Function Title: Transport Loaded Cask

III. Function Definition:

The loaded cask is moved over a designated road, rail or barge route in accordance with a specific plan. It includes the integration of both escort and inspection activities that may occur enroute.

IV. Interfaces:

A. Inputs: None identified at this time

B. Outputs: None identified at this time

V. Requirements:

A. Constraints:

1.2.2.2.1C1 Responsibility for compliance.

Unless this subchapter specifically provides that another person is to perform a particular duty, each carrier, including a connecting carrier, shall perform the duties specified and comply with each applicable requirement of this part, and shall instruct its employees in relation thereto. [49 CFR 174.7]

1.2.2.2.1C2 In loading and storage areas, each fissile Class III shipment must be segregated by a distance of at least 6 m (20 feet) from other packages required to bear one of the "radioactive" labels described in Part 172 of this subchapter

[49 CFR 174.700]

1.2.2.2.1C3 Responsibility for compliance

Unless this subchapter specifically provides that another person must perform a duty, each carrier, including a connecting carrier, shall comply with all applicable regulations in this part, and shall thoroughly instruct his employees in relation thereto.

[49 CFR 176.13]

1.2.2.2.1C4 Subpart A -- General Information and Regulations

Compliance with Federal Motor Carrier Safety Regulations.

Motor carriers and other persons subject to this part shall comply with 49 CFR Parts 390 through 397 (excluding Sections 397.3 and 397.9) to the extent those rules apply.

[49 CFR 177.804]

1.2.2.2.1C5 (2) A motor vehicle may be operated over a route, other than a preferred route, only under the following conditions:

(i) The deviation from the preferred route is necessary to pick up or deliver a highway route controlled quantity of Class 7 (radioactive) materials, to make necessary rest, fuel or motor vehicle repair stops, or because emergency conditions make continued use of the preferred route unsafe or impossible;

(ii) For pickup and delivery not over preferred routes, the route selected must be the shortest-distance route from the pickup location to the nearest preferred route entry location, and the shortest-distance route to the delivery location from the nearest preferred route exit location. Deviation from the shortest-distance pickup or delivery route is authorized if such deviation:

(A) Is based upon the radiological risk minimization criteria of paragraph (a) of this section; and

(B) Does not exceed the shortest-distance pickup or delivery route by more than 25 miles and does not exceed 5 times the length of the shortest-distance pickup or delivery route.

(iii) Deviations from preferred routes, or pickup or delivery routes other than preferred routes, which are necessary for rest, fuel, or motor vehicle repair stops or because of emergency conditions, shall be made in accordance with the radiological risk minimization criteria of paragraph (a) of this section unless, due to emergency conditions, time does not permit use of those criteria.

[49 CFR 177.825(b)]

1.2.2.2.1C6 In loading and storage areas each fissile class III shipment must be segregated by a distance of at least 6 m (20 feet) from other packages required to bear one of the "Radioactive" labels described in Sec. 172.403 of this subchapter.

[49 CFR 177.842 (f)]

B. Performance: None specified at this time

C. Interface: None specified at this time

Table F1.2.2.2 Function Description: Acquire In-Transit Permits

I. Function ID Number: 1.2.2.2.2

II. Function Title: Acquire In-Transit Permits

III. Function Definition:

The carrier, with support from the Manage Traffic Function, obtains special transport permits and makes special arrangements/notifications as required. The carrier and the Manage Traffic Function closely coordinate their activities in order to assure compliance with regulatory requirements and meet commitments made prior to and during movement. Operations personnel in the OCC may be called upon to obtain in-transit permits.

IV. Interfaces:

A. Inputs: None identified at this time

B. Outputs: None identified at this time

V. Requirements:

A. Constraints: None specified at this time

B. Performance: None specified at this time

C. Interface: None specified at this time

Table F1.2.2.3 Function Description: Perform In-Transit Repairs

I. Function ID Number: 1.2.2.2.3

II. Function Title: Perform In-Transit Repairs

III. Function Definition:

The carrier determines the need for repairs to the prime mover, the transporter and the cask system to transporter interface. He coordinates this determination with the Manage Traffic Function and, in accordance with the Manage Traffic Function, identifies the location at which repairs will be made. Additional security actions may be required by the carrier and the Security Function.

IV. Interfaces:

- A. Inputs:** None identified at this time
B. Outputs: None identified at this time

V. Requirements:

A. Constraints:

1.2.2.2.3C1 (c) Shipments by road. In addition to the provisions of paragraph (b), the physical protection system for any portion of a spent fuel shipment that is by road shall provide that: ...

(3) Escorts have the capability of communicating with the communications center, local law enforcement agencies, and one another, through the use of:

- (i) A citizens band (CB) radio available in the transport vehicle and in each escort vehicle;
- (ii) A radiotelephone or other NRC-approved equivalent means of two-way voice communications available in the transport vehicle or in an escort vehicle committed to travel the entire route; and
- (iii) Citizens band (CB) radio and normal local law enforcement agency radio communications in any local law enforcement agency mobile units used for escort purposes.

[10 CFR 73.37]

- B. Performance:** None specified at this time
C. Interface: None specified at this time
-
-

Table F1.2.2.2.4 Function Description: Perform Security Functions

- I. Function ID Number:** 1.2.2.2.4
II. Function Title: Perform Security Functions
III. Function Definition:

Intransit security is implemented in accordance with requirements of the Physical Security Plan developed for the shipment. The Plan provides the requirements for escorts and supplementary security during rest stops or repairs, the requirements for carrier - Manage Traffic Function communications during movement, stops and repairs, and the requirements for written log maintenance. The Plan also provides requirements to be implemented in response to security incidents.

IV. Interfaces:

- A. Inputs:** None identified at this time
B. Outputs: None identified at this time

V. Requirements:

A. Constraints:

1.2.2.2.4C1 (a) Performance objectives.

- (1) Each licensee who transports, or delivers to a carrier for transport, in a single
-

shipment, a quantity of irradiated reactor fuel in excess of 100 grams in net weight of irradiated fuel, exclusive of cladding or other structural or packaging material, which has a total external radiation dose rate in excess of 100 rems per hour at a distance of 3 feet from any accessible surface without intervening shielding, shall establish and maintain, or make arrangements for, and assure the proper implementation of, a physical protection system for shipments of such material that will achieve the following objectives:

- (i) Minimize the possibilities for radiological sabotage of spent fuel shipments, especially within heavily populated areas; and
- (ii) Facilitate the location and recovery of spent fuel shipments that may have come under the control of unauthorized persons.

(2) To achieve these objectives, the physical protection shall:

- (i) Provide for early detection and assessment of attempts to gain unauthorized access to, or control over, spent fuel shipments;
- (ii) Provide for notification to the appropriate response forces of any spent fuel shipment sabotage attempts; and
- (iii) Impede attempts at radiological sabotage or spent fuel shipments within heavily populated areas, or attempts to illicitly move such shipments into heavily populated areas, until response forces arrive.

[10 CFR 73.37]

1.2.2.2.4C2 (b) General requirements. To achieve the performance objectives of paragraph (a) of this section, a physical protection system established and maintained, or arranged for, by the licensee shall: ...

(5) Provide for maintenance of a written log by the escorts and communications center personnel for each spent fuel shipment, which will include information describing the shipment and significant events that occur during the shipment, and will be available for review by authorized NRC personnel for a period of at least three years following completion of the shipment ...

(9) Provide that at least one escort maintains visual surveillance of the shipment during periods when the shipment vehicle is stopped, or the shipment vessel is docked ...

(11) Provide that shipment escorts make calls to the communications center at least every 2 hours to advise of the status of the shipment for road and rail shipments, and for sea shipments while shipment vessels are docked at U.S. ports.

[10 CFR 73.37]

1.2.2.2.4C3 (c) Shipments by road. In addition to the provisions of paragraph (b), the physical protection system for any portion of a spent fuel shipment that is by road shall provide that: ...

(4) The transport is equipped with NRC-approved features that permit immobilization of the cab or cargo-carrying portion of the vehicle.

[10 CFR 73.37]

1.2.2.2.4C4 (d) Shipments by rail. In addition to the provisions of paragraph (b), the physical protection system for any portion of a spent fuel shipment that is by rail shall provide that:

(1) A shipment car within a heavily populated area is accompanied by two armed escorts (who may be members of a local law enforcement agency), at least one of whom is stationed at a location on the train that will permit observation of the shipment car while in motion.

(2) A shipment car not within any heavily populated area is accompanied by at least one escort stationed at a location on the train that will permit observation of the shipment car while in motion ...

(3) Escorts have the capability of communicating with the communications center and local law enforcement agencies through the use of a radiotelephone, or other NRC-approved equivalent means of two-way voice communications, which shall be available on the train.

[10 CFR 73.37]

1.2.2.2.4C5 (e) Shipments by sea. In addition to the provisions of paragraph (b), the physical protection system for any portion of a spent fuel shipment that is by sea shall provide that:

(1) A shipment vessel, while docked at a U.S. port within a heavily populated area, is protected by:

(i) Two armed escorts stationed on board the shipment vessel, or stationed on the dock at a location that will permit observation of the shipment vessel; or

(ii) A member of a local law enforcement agency, equipped with normal LLEA radio communications, who is stationed on board the shipment vessel, or on the dock at a location that will permit observation of the shipment vessel.

(2) A shipment vessel, while within U.S. territorial waters, or while docked at a U.S. port not within a heavily populated area, is accompanied by an escort, who may be an officer of the shipment vessel's crew, who will assure that the shipment is unloaded only as authorized by the licensee.

(3) Escorts have the capability of communicating with the communications center and local law enforcement agencies through the use of a radiotelephone, or other NRC-approved equivalent means of two-way voice communications.

[10 CFR 73.37]

B. Performance: None specified at this time

C. Interface: None specified at this time

Table F1.2.2.2.5 Function Description: Perform Intermodal Transfers

I. Function ID Number: 1.2.2.2.5

II. Function Title: Perform Intermodal Transfers

III. Function Definition:

Intermodal transfers may be required to transport loaded casks from the purchaser/producer site to either a rail head or a barge slip. The cask/skid system is placed on a heavy haul trailer and moved over a designated route to the transfer site. Special lifting equipment may be required to transfer the cask/skid to the rail transporter or barge. Transfer from the barge to the transporter for movement to the MRS or repository also requires special lifting equipment. Other transfer approaches may be developed for special situations.

IV. Interfaces:

A. Inputs: None identified at this time

B. Outputs: None identified at this time

V. Requirements:

A. Constraints: None specified at this time

B. Performance: None specified at this time

C. Interface: None specified at this time

Table F1.2.2.3 Function Description: Deliver Shipment

I. Function ID Number: 1.2.2.3

II. Function Title: Deliver Shipment

III. Function Definition:

The loaded cask is delivered to the repository or the MRS.

IV. Interfaces:

A. Inputs:

1.2.2.3I1	Loaded SNF Shipment	From: Function 1.2.2.2
1.2.2.3I2	Loaded CHLW Shipment	From: Function 1.2.2.2
1.2.2.3I3	Loaded DHLW Shipment	From: Function 1.2.2.2

B. Outputs:

1.2.2.3O1	Loaded SNF Casks/Transporters	To: Function 1.3 / 1.4
1.2.2.3O2	Loaded CHLW Casks/Transporters	To: Function 1.4
1.2.2.3O3	Loaded DHLW Casks/Transporters	To: Function 1.4
1.2.2.3O4	Shipping Documents	To: Function 1.3 / 1.4
1.2.2.3O5	Prime Mover and Crew	To: Private Transportation Industry
1.2.2.3O6	Arrival Notification	To: Function 1.2.2.4

V. Requirements:

A. Constraints: None specified at this time

B. Performance: None specified at this time

C. Interface:

1.2.2.3I1 None specified at this time

1.2.2.3I2 None specified at this time

1.2.2.3I3 None specified at this time

1.2.2.3O1 None specified at this time

1.2.2.3O2 None specified at this time

1.2.2.3O3 None specified at this time

1.2.2.3O4 None specified at this time

1.2.2.305 Contamination of vehicles.

(a) Each motor vehicle used for transporting Class 7 (radioactive) materials under exclusive use conditions in accordance with Sec. 173.425(c) or Sec. 173.443(c) shall be surveyed with radiation detection instruments after each use. A vehicle may not be returned to service until the radiation dose rate at each accessible surface is 0.5 millirem per hour or less and the removable (non-fixed) radioactive surface contamination is not greater than the level prescribed in Sec. 173.443(a).
[49 CFR 177.843]

1.2.2.306 None specified at this time

Table F1.2.2.3.1 Function Description: Position Loaded Cask/Transporter

I. Function ID Number: 1.2.2.3.1

II. Function Title: Position Loaded Cask/Transporter

III. Function Definition:

The carrier positions the transporter with loaded cask at an MRS or Repository designated location, disconnects the prime mover, set brakes, and chocks wheels. Subsequent repositioning is expected to be the responsibility of the receiver.

IV. Interfaces:

A. Inputs: None identified at this time

B. Outputs: None identified at this time

V. Requirements:

A. Constraints:

1.2.2.3.1C1 Procedures for receiving and opening packages.

(b) Each licensee shall monitor the external surfaces of a package known to contain radioactive material for radioactive contamination and radiation levels if the package--

(1) Is labeled as containing radioactive material; or

(2) Has evidence of potential contamination, such as packages that are crushed, wet, or damaged.

(c) The licensee shall perform the monitoring required by paragraph (b) of this section as soon as practicable after receipt of the package, but not later than 3 hours after the package is received at the licensee's facility if it is received during the licensee's normal working hours, or not later than 3 hours from the beginning of the next working day if it is received after working hours.
[10 CFR 20.1906]

B. Performance: None specified at this time

C. Interface: None specified at this time

Table F1.2.2.3.2 Function Description: Debrief Transportation Crew

I. Function ID Number: 1.2.2.3.2

II. Function Title: Debrief Transportation Crew

III. Function Definition:

The carrier crew is debriefed by OCRWM upon delivery of the loaded cask to the repository or the MRS. The results of the inspection and survey of the prime mover, the transporter and cask are available for the debriefing.

IV. Interfaces:

A. Inputs: None identified at this time

B. Outputs: None identified at this time

V. Requirements:

A. Constraints: None specified at this time

B. Performance: None specified at this time

C. Interface: None specified at this time

Table F1.2.2.3.3 Function Description: Transfer Shipping Documents

I. Function ID Number: 1.2.2.3.3

II. Function Title: Transfer Shipping Documents

III. Function Definition:

The entire shipping documents package is delivered to the consignee, along with any supplemental documentation provided by the shipper.

IV. Interfaces:

A. Inputs:

1.2.2.3.3I1 Shipping Documents **From:** Function 1.2.2.1.3

B. Outputs:

1.2.2.3.3O1 Shipping Documents **To:** Function 1.3 / 1.4

V. Requirements:

A. Constraints: None specified at this time

B. Performance: None specified at this time

C. Interface: None specified at this time

Table F1.2.2.4 Function Description: Manage Traffic

- I. Function ID Number:** 1.2.2.4
- II. Function Title:** Manage Traffic
- III. Function Definition:**

Manage Traffic provides both administration and operations functions that arrange and coordinate, respectively, the shipment of loaded casks. The Administrative function arranges for the arrival of prime movers for shipments based on the Campaign Plans. The Operations function coordinates the movement of the loaded casks systems from the purchaser/producer sites to the NWMS facility and between NWMS facilities. The Operations function performs communications, control, support, and oversight. Traffic management is a level of effort activity which commences when the shipping activities begin and runs throughout the life of the transportation system.

IV. Interfaces:

A. Inputs:

1.2.2.4I1	Arrival Notification	From: Function 1.2.2.3
1.2.2.4I2	Shipment Status Information	From: Function 1.2.2.2
1.2.2.4I3	Schedules, Plans	From: Function 1.2.3.1 / 1.2.3.1.1
1.2.2.4I4	Information	From: Function 1.3 / 1.4

B. Outputs:

1.2.2.4O1	Operations Orders	To: Function 1.2.2.1 (Control)
1.2.2.4O2	Revised Operations Orders	To: Function 1.2.2.2 (Control)
1.2.2.4O3	Advance Notices	To: NRC, States, Tribes / Function 1.3 / 1.4
1.2.2.4O4	Emergency Information	To: NRC, States, Tribes, DOE Emergency Operations Center

V. Requirements:

A. Constraints

1.2.2.4C1 Completeness and accuracy of information.

(a) Information provided to the Commission by an applicant for a license or by a licensee or information required by statute or by the Commission's regulations, orders, or license conditions to be maintained by the applicant or the licensee shall be complete and accurate in all material respects.

[10 CFR 71.6a]

B. Performance: None specified at this time

C. Interface:

1.2.2.4I1 None specified at this time

1.2.2.4I2 None specified at this time

1.2.2.4O1 None specified at this time

1.2.2.4O2 None specified at this time

1.2.2.403 Same as 1.2.2.4C1 above.

1.2.2.404 Same as 1.2.2.4C1 above.

Table F1.2.2.4.1 Function Description: Prepare/Coordinate Traffic Flow Schedules

I. Function ID Number: 1.2.2.4.1

II. Function Title: Prepare/Coordinate Traffic Flow Schedules

III. Function Definition:

In support of the campaign planning, responsible operational personnel will develop and coordinate transportation schedules which will identify and provide for the equipment, services, and support to meet the objectives and milestones within the campaign plans. This will include integration of physical movements of equipment and loaded casks such that competing demands for services, equipment, facilities, and support are resolved, and that special conditions and restrictions are properly fulfilled. Traffic management personnel will coordinate all schedules with the purchaser or shipping activity, the field operations teams and security escorts, the applicable receiving activity, the supporting transportation service organization(s) [railroads, trucking companies, barging companies, riggers, etc], and applicable state and local officials. While most schedules may be campaign specific, the coordination of these schedules is a level of effort activity which commences when shipping activities begin and runs throughout the life of the transportation system.

IV. Interfaces:

A. Inputs: None identified at this time

B. Outputs: None identified at this time

V. Requirements:

A. Constraints:

1.2.2.4.1C1 OPERATING PROCEDURES

g. Notification Procedures for Shipment and Nonreceipt of Radioactive Materials. To reduce to a minimum the number of shipments that must ultimately be considered lost, the following procedures shall be implemented:

- (1) Prior to each shipment of fissile radioactive materials, or shipments of more than Type A quantity of radioactive material, the shipper shall notify the consignee of the dates of the shipment and of expected arrival. The shipper shall also notify each consignee of any special loading or unloading instructions prior to his or her first shipment.

[DOE Order 5480.3, 10]

B. Performance: None specified at this time

C. Interface: None specified at this time

Table F1.2.2.4.2 Function Description: Issue Transport Notifications

I. Function ID Number: 1.2.2.4.2

II. Function Title: Issue Transport Notifications

III. Function Definition:

In accordance with the operational procedures, campaign plans, and coordinated schedules, appropriate notices are issued to NRC, DOT, appropriate state, local, and tribal authorities, and shipping and receiving activities.

IV. Interfaces:

A. Inputs: None identified at this time

B. Outputs: None identified at this time

V. Requirements:

A. Constraints:

1.2.2.4.2C1 (a) Except as specified in paragraph (b) of this section, prior to the transport or delivery to a carrier for transport of licensed material outside the confines of the licensee's plant or other place of use or storage, each licensee shall provide advance notification to the governor of a state, or the governor's designee, of the shipment to, through, or across the boundary of the state.

(b) Advance notification is required only when:

(1) The licensed material is required by this part to be in Type B packaging for transportation;

(2) The licensed material other than irradiated fuel is being transported to, through, or across state boundaries to a disposal site or to a collection point for transport to a disposal site;

(3) The quantity of licensed material in a single package exceeds:

(i) 5,000 curies of special form radionuclides;

(ii) 5,000 curies of uncompressed gases of Argon - 41, Krypton -85m, Krypton - 87, Xenon - 131m, or Xenon - 135;

(iii) 50,000 curies of Argon - 37, or of uncompressed gases of Krypton - 85 or Xenon - 133, or of Hydrogen - 3 as a gas, as luminous paint, or adsorbed on solid material;

(iv) 20 curies of other non-special form radionuclides for which A_2 is less than or equal to four curies; or

(v) 200 curies of other non-special form radionuclides for which A_2 is greater than four curies; and

(4) The quantity of irradiated fuel is less than that subject to advance notification requirements of 10 CFR Part 73.

(c) Procedures for submitting advance notification.

(1) The notification must be made in writing to the office of each appropriate governor or governor's designee and to the Regional Administrator of the appropriate Nuclear Regulatory Commission Regional Office listed in Appendix A of Part 73 of this chapter.

(2) A notification delivered by mail must be postmarked at least seven days before the beginning of the seven-day period during which departure of the shipment is estimated to occur.

(3) A notification delivered by messenger must reach the office of the governor or of the governor's designee at least four days before the beginning of the seven-day period during which departure of the shipment is estimated to occur.

(i) A list of the names and mailing addresses of the governors' designees receiving advance notification of transportation of nuclear waste was published in the Federal Register on June 30, 1983 (48 FR 30221).

(ii) The list will be published annually in the Federal Register on or about June 30 to reflect any changes in information.

(iii) A list of the names and mailing addresses of the governors' designees is available upon request from the Director, Office of Governmental and Public Affairs, U.S. Nuclear Regulatory Commission, Washington, DC 20555.

(4) The licensee shall retain a copy of the notification as a record for three years.

(d) Information to be furnished in advance notification of shipment. Each advance notification of shipment of nuclear waste must contain the following information:

(1) The name, address, and telephone number of the shipper, carrier, and receiver of the nuclear waste shipment;

(2) A description of the nuclear waste contained in the shipment, as required by the regulations of DOT in 49 CFR 172.202 and 172.203(d);

(3) The point of origin of the shipment and the seven-day period during which departure of the shipment is estimated to occur;

(4) The seven-day period during which arrival of the shipment at state boundaries is estimated to occur;

(5) The destination of the shipment, and the seven-day period during which arrival of the shipment is estimated to occur; and

(6) A point of contact with a telephone number for current shipment information.

(e) Revision notice. A licensee who finds that schedule information previously furnished to a governor or governor's designee in accordance with this section will not be met, shall telephone a responsible individual in the office of the governor of the State or of the governor's designee and inform that individual of the extent of the delay beyond the schedule originally reported. The licensee shall maintain a record of the name of the individual contacted for three years.

(f) Cancellation notice.

(1) Each licensee who cancels a nuclear waste shipment for which advance notification has been sent, shall send a cancellation notice to the governor of each state or the governor's designee previously notified and to the Regional Administrator of the appropriate Nuclear Regulatory Commission Regional Office listed in Appendix A of Part 73 of this chapter.

(2) The licensee shall state in the notice that it is a cancellation and shall identify the advance notification which is being cancelled. The licensee shall retain a copy of the notice as a record for three years.

[10 CFR 71.97]

1.2.2.4.2C2 (b) General requirements. To achieve the performance objectives of paragraph (a) of this section, a physical protection system established and maintained, or arranged for, by the licensee shall: ...

(1) Provide for notification of the Nuclear Regulatory Commission in advance of each shipment, in accordance with Sec. 73.72 of this part ...

(6) Provide that arrangements have been made with local law enforcement agencies along the routes of road and rail shipments, and at U.S. ports where vessels carrying spent fuel shipments are docked, for their response to an emergency or a call for assistance.

[10 CFR 73.37]

1.2.2.4.2C3 (f) Prior to the transport of spent fuel within or through a state a licensee subject to this section shall notify the governor or the governor's designee. The licensee shall comply with the following criteria in regard to a notification:

(1) The notification must be in writing and sent to the office of each appropriate governor or the governor's designee. A notification delivered by mail must be postmarked at least 7 days before transport of a shipment within or through the state. A notification delivered by messenger must reach the office of the governor or the governor's designee at least 4 days before transport of a shipment within or through the state. A list of the mailing addresses of governors and governors' designees is available upon request from the Director, Office of Governmental and Public Affairs, U.S. Nuclear Regulatory Commission, Washington, D.C. 20555.

(2) The notification must include the following information:

(i) The name, address, and telephone number of the shipper, carrier and receiver.

(ii) A description of the shipment as specified by the Department of Transportation in 49 CFR Sec. 172.202 and Sec. 172.203(d).

(iii) A listing of the routes to be used within the state.

(iv) A statement that the information described below in Sec. 73.37(f)(3) is required by NRC regulations to be protected in accordance with the requirements of Sec. 73.21.

(3) The licensee shall provide the following information on a separate enclosure to the written notification:

(i) The estimated date and time of departure from the point of origin of the shipment.

(ii) The estimated date and time of entry into the governor's state.

(iii) For the case of a single shipment whose schedule is not related to the schedule of any subsequent shipment, a statement that schedule information must be protected in accordance with the provisions of Sec. 73.21 until at least 10 days after the shipment has entered or originated within the state.

(iv) For the case of a shipment in a series of shipments whose schedules are related, a statement that schedule information must be protected in accordance with the provisions of Sec. 73.21 until 10 days after the last shipment in the series has entered or originated within the state and an estimate of the date on which the last shipment in the series will enter or originate within the state.

(4) A licensee shall notify by telephone or other means a responsible individual in the office of the governor or in the office of the governor's designee of any schedule change that differs by more than 6 hours from the schedule information previously furnished in accordance with Sec. 73.37(f)(3), and shall inform that individual of the number of hours of advance or delay relative to the written schedule information previously furnished.

[10 CFR 73.37]

1.2.2.4.2C4³ SHIPMENT NOTIFICATION POLICY. It is the policy of the DOE, applicable to all contractor shippers, to provide advance written notification on all shipments of unclassified high-level radioactive waste and spent nuclear fuel to the designated representatives to the States through which any such shipments will pass.

For the purpose of this policy, the definitions of irradiated reactor fuel or "spent fuel" and "high-level radioactive waste" are those found in DOE 1540.4.

³ Note that this requirement is in conflict with 10 CFR 73.37 in 1.2.2.4.2C3.

a. DOE Unclassified Spent Fuel.

(1) The notification must be in writing and sent by registered letter, return receipt, to the office of each appropriate Governor or Governor's designee. A notification delivered by mail must be postmarked at least 7 days before transport of a shipment within or through the State. A notification delivered by messenger must reach the office of the Governor or Governor's designee at least 4 days before transport of a shipment within or through the State. A list of the mailing addresses of Governors or Governors' designees has been provided to the Manager of each operations office. Updates of this list are published each year in the June 30 issue of the Federal Register. Shippers unable to obtain the latest Federal Register listing locally should contact the Transportation Management Division (EM-50).

(2) The notification must include the following information:

- (a) The name, address, and telephone number of the shipper, carrier and receiver.
- (b) A description of the shipment as specified by the DOT in 49 CFR, Parts 172.202 and 172.203(d).
- (c) A listing of the routes to be used within the State.
- (d) The estimated date and time of departure from the point of origin.
- (e) The estimated date and time of entry into the Governor's State.
- (f) The estimated date and time of departure from the Governor's State (in such cases where the destination is not within the State).
- (g) A statement that the information is required by DOE to be protected against unauthorized disclosure.

(3) A DOE shipper shall notify, by telephone or other means, a responsible individual in the office of the Governor or the Governor's designee of any schedule change that differs by more than 6 hours from the schedule information previously furnished in the written notification.

(4) Notice of cancellation of a spent fuel shipment can be made by telephone to each State affected. No written notice of cancellation must be made to the States. A record should be retained of the responsible individual contacted about the cancellation of the shipment.

b. DOE Unclassified High-Level Radioactive Waste.

(1) The requirements for timely submission of notification on shipments of unclassified high-level radioactive waste are the same as those cited in paragraph 8a(1) of this Chapter for shipments of unclassified spent fuel.

(2) The notification must include the following information:

- (a) The name, address, and telephone number of the shipper, carrier, and receiver.
- (b) The address of the point of origin of the shipment and a 7-day period during which departure of the shipment is estimated to occur.
- (c) A description of the waste shipment as specified by the DOE in 49 CFR Parts 172.202 and 172.203(d).
- (d) A 7-day period during which arrival at the State boundaries is estimated to occur.
- (e) The destination of the shipment and the 7-day period during which arrival of the shipment is estimated to occur.
- (f) A point of contact with a telephone number for current shipment information.

(g) A statement that the information is required to be protected against unauthorized disclosure.

(3) A DOE shipper shall notify, by telephone or other means, a responsible individual in the office of the Governor's designee of any change from the schedule information previously furnished in the written notification.

(4) The provisions for the cancellation of a shipment of high-level waste are the same as those cited for a shipment of spent fuel in paragraph 8a(4) of this Chapter.
[DOE Order 1540.1, CH-II,8]

1.2.2.4.2C5 Prior to each shipment of fissile radioactive materials, and Type B or highway route controlled quantity packages of radioactive materials (see Section 173.403), the shipper shall notify the consignee of the dates of shipment and expected arrival. The shipper shall also notify each consignee of any special loading/unloading instructions prior to his first shipment. For any shipment of irradiated reactor fuel, the shipper shall provide physical protection in compliance with a plan established under:

(1) Requirements prescribed by the U.S. Nuclear Regulatory Commission, or

(2) Equivalent requirements approved by the Director, Office of Hazardous Materials Transportation, RSPA.

[49 CFR 173.22 (c)]

B. Performance: None specified at this time

C. Interface: None specified at this time

Table F1.2.2.4.3 Function Description: Monitor Traffic Flow Status

I. Function ID Number: 1.2.2.4.3

II. Function Title: Monitor Traffic Flow Status

III. Function Definition:

Transport communications activities and performance are continuously monitored to identify potential problems and conflicts and to make or recommend changes to schedules, routes, and other transportation activities to resolve problems. In addition, logs are maintained to collect and record information on performance related to schedules, document schedule changes, and provide information that can be used to improve transportation management and scheduling operations. Monitoring of traffic flow is a level of effort activity and commences once shipping activities begin and continues throughout the life of the Transportation System.

IV. Interfaces:

A. Inputs: None identified at this time

B. Outputs: None identified at this time

V. Requirements:

A. Constraints: None specified at this time

B. Performance:	None specified at this time
C. Interface:	None specified at this time

Table F1.2.2.4.4 Function Description: Coordinate Traffic Communications

- I. Function ID Number:** 1.2.2.4.4
- II. Function Title:** Coordinate Traffic Communications
- III. Function Definition:**

Prior to and throughout each campaign, communications support is provided between the OCC, the transport conveyance, the MRS or MGDS as appropriate, and state, local, and tribal officials, as required. Communications support includes, but is not limited to, communication equipment, personnel, procedures and reporting requirements to assure that all transportation support is adequately monitored and a means is provided to transmit and receive information to support transport operations and security. Coordination, as it is referred to here, is the process of assuring that the communications hardware, software, and personnel have been put in place and maintained during all shipping activities to support transportation and security operations. This function commences once shipping activities begin and continues throughout the life of the Transportation System.

IV. Interfaces:

- A. Inputs:** None identified at this time
- B. Outputs:** None identified at this time

V. Requirements:

A. Constraints:

1.2.2.4.4C1 (b) General requirements. To achieve the performance objectives of paragraph (a) of this section, a physical protection system established and maintained, or arranged for, by the licensee shall: ...

(4) Include a communications center at a designated location, which will be staffed continuously by at least one individual who will monitor the progress of the spent fuel shipment and will notify the appropriate agencies in the event a safeguards emergency should arise.

(5) Provide for maintenance of a written log by the escorts and communications center personnel for each spent fuel shipment, which will include information describing the shipment and significant events that occur during the shipment, and will be available for review by authorized NRC personnel for a period of at least three years following completion of the shipment.

[10 CFR 73.37]

- B. Performance:** None specified at this time
- C. Interface:** None specified at this time
-

Table F1.2.2.4.5 Function Description: Issue Dispatch Orders

- I. Function ID Number:** 1.2.2.4.5
- II. Function Title:** Issue Dispatch Orders
- III. Function Definition:**

Dispatch operations performs logging and tracking functions (e.g., times of arrival, departure, and intermediate contacts; shipment status; location; progress; and conditions) and provides support, via a communications link, to the in-transit vehicles and operators. The support may include information such as where needed maintenance services might be obtained, assistance in replacing failed equipment, replacement of operators who cannot continue, instructions for diversions in route, meeting ex-vehicle escorts (if required), obtaining in transit permits, and support in emergency conditions, including dispatch of emergency medical, police, and accident mitigation services.

Dispatch orders are the execution mechanism by which transportation support and services are provided. Dispatch orders may consist of an order to a carrier to provide equipment or services at a specific place and time, or to an operator to move a cask from one place to another. The dispatch order provides specific instructions to a carrier that include routing and alternate routing instructions. Issuance of dispatch orders is keyed to schedules and accomplishment of specific activities, such as completion of all preparations for shipment of a cask. Initial preparation of the dispatch order commences with receipt of a coordinated schedule and terminates with delivery of the dispatch order to the carrier.

- IV. Interfaces:**
 - A. Inputs:** None identified at this time
 - B. Outputs:** None identified at this time
- V. Requirements:**
 - A. Constraints:** None specified at this time
 - B. Performance:** None specified at this time
 - C. Interface:** None specified at this time

Table F1.2.2.4.6 Function Description: Obtain Special Transport Permits

- I. Function ID Number:** 1.2.2.4.6
- II. Function Title:** Obtain Special Transport Permits
- III. Function Definition:**

Special transport permits required by Federal, state, and local laws and regulations are obtained prior to commencement of each shipment. These include state and local permits for loaded cask movements, where oversize or overweight conditions exist along the route. This activity commences with completion of a coordinated campaign plan and terminates with delivery of the permits to the carrier's operators, or it commences with notification of OCC personnel that an event has occurred which has generated the requirement for a special permit and terminates when the operator of the equipment requiring the permit receives the permit.

IV. Interfaces:

A. Inputs: None identified at this time

B. Outputs: None identified at this time

V. Requirements:

A. Constraints:

1.2.2.4.6C1 COMPLIANCE WITH TRANSPORTATION LAWS OR REGULATIONS

c. Size and Weight Limitations for Highway shipments. Motor carrier shipments shall conform to State and local laws, regulations, and ordinances relating to weight and size limitations. No vehicular movement which exceeds any State's legal weight or size limitation shall be undertaken over public highways unless prior permission is formally granted by the state concerned. The Department or Department's contractor support of a carrier requesting such permission may be furnished only after a determination that it is not practical to divide the load into smaller lots or feasible to move the material by other means of transportation.

[DOE Order 1540.1, CH-1,4]

B. Performance: None specified at this time

C. Interface: None specified at this time

Table F1.2.2.4.7 Function Description: Support Emergency Response Communications

I. Function ID Number: 1.2.2.4.7

II. Function Title: Support Emergency Response Communications

III. Function Definition:

Communications during emergencies is provided among on-scene personnel, NWMS personal, and Federal, State, and local officials. Communications to direct NWMS emergency response teams and monitor activities and progress is also provided. The emergency response communications capability will be required from the commencement of transportation operations and will run throughout the life of the program, but would only be employed from notification of an emergency until the appropriate authorities declare an end of the emergency.

IV. Interfaces:

A. Inputs: None identified at this time

B. Outputs: None identified at this time

V. Requirements:

A. Constraints:

1.2.2.4.7C1 Emergency response telephone number.

(a) A person who offers a hazardous material for transportation must provide a 24-hour emergency response telephone number (including the area code or international access code) for use in the event of an emergency involving the hazardous material. The telephone number must be--

(1) Monitored at all times the hazardous material is in transportation, including storage incidental to transportation;

(2) The number of a person who is either knowledgeable of the hazards and characteristics of the hazardous material being shipped and has comprehensive emergency response and incident mitigation information for that material, or has immediate access to a person who possesses such knowledge and information; and

(3) Entered on a shipping paper, as follows:

(i) Immediately following the description of the hazardous material required by Subpart C of this Part 172; or

(ii) Entered once on the shipping paper in a clearly visible location. This provision may be used only if the telephone number applies to each hazardous material entered on the shipping paper, and if it is indicated that the telephone number is for emergency response information (for example: "EMERGENCY CONTACT: ***").

(b) The telephone number required by paragraph (a) of this section must be the number of the person offering the hazardous material for transportation or the number of an agency or organization capable of, and accepting responsibility for, providing the detailed information concerning the hazardous material. A person offering a hazardous material for transportation who lists the telephone number of an agency or organization shall ensure that agency or organization has received current information on the material, as required by paragraph (a)(2) of this section before it is offered for transportation.

[49 CFR 172.604]

1.2.2.4.7C2 All DOE-owned shipments of radioactive and other hazardous materials, substances, and wastes will comply with the DOE requirements for Emergency Response Information cited in 49 CFR, Subpart G, Sections 172.600 - 172.604.

[DOE Order 1540.1, Ch II, 7(c)(3)]

1.2.2.4.7C3 OCCURRENCE CATEGORIZATION, NOTIFICATION AND REPORTING REQUIREMENTS.

a. **Categorization.** Categorization of Reportable Occurrences shall be made as soon as practicable and, in all cases, within 2 hours of identification. If categorization is not clear, then the occurrence shall be initially categorized at the higher level being considered and DOE notified in accordance with this Order. The occurrence categorization shall either be elevated, maintained, or lowered as information is made available. The categories of Reporting Occurrences are:

(1) **Emergencies.** Emergencies are the most serious occurrences and require an increased alert status for onsite personnel and, in specified cases, for offsite authorities. The detailed definitions and classifications of emergencies and appropriate emergency responses to be taken are provided in DOE 5500.2B. The types of occurrences that are to be categorized as emergencies are:

(a) Any unintentional nuclear criticality that results or could result in actual or potential facility damage or release of radioactive material to the environment;

(b) Any actual or potential release of material to the environment which results or could result in significant offsite consequences;

(c) Any natural or man-made event posing an actual or potential threat to the integrity of the facility, that results or could result in significant offsite consequences;

(d) Any event in process or having occurred which involves an actual or potential substantial degradation of the level of safety of the facility that results or could result in significant offsite consequences; or

(e) Any safeguards or security event which is an actual or potential threat to DOE operations, facilities, or personnel, and results or could result in significant effects on the public health and safety and/or on national security.

(f) Any event which requires activation of the site emergency plan.

(2) Unusual Occurrences. An unusual occurrence is a non-emergency occurrence that has significant impact or potential for impact on safety, environment, health, security, or operations. The types of occurrences that are to be categorized as unusual occurrences are those that:

(a) Result in the release of radioactive or hazardous materials above limits established in, or violate safety, environment, or health requirements defined in, permits or regulations;

(b) Are significant internal or external threats to safety, environment, or health protection or the ability of a facility to operate;

(c) Involve significant degradation of safety systems or environmental, safety, or health conditions;

(d) Result in fatalities, exposures to hazardous or radioactive materials or offsite or onsite contamination in excess of regulatory allowable limits, but less than protective response recommendations as defined in DOE 5500.3A, failure of environmental monitoring equipment necessary to demonstrate compliance, failure of safety equipment or systems reducing the capability below a minimum required safety function, or significant delay or cost in operations;

(e) Result in the actuation of emergency systems or engineered safety features, except under approved testing;

(f) Violate technical specifications, operational safety requirements, or involve an unreviewed safety question;

(g) Violate DOE safety requirements, environmental requirements, or result in the loss of control or release of radioactive material above allowable limits; or

(h) Result in the release of a hazardous substance or material that exceeds a reportable quantity and is not federally permitted as defined in Attachment I.

(3) Off-Normal Occurrences. Off-normal occurrences are abnormal or unplanned events or conditions that adversely affect, potentially affect, or are indicative of degradation in, the safety, security, environmental or health protection performance or operation of a facility. The types of occurrences that are to be categorized as off-normal occurrences are those that:

(a) Are internal or external threats to safety, environmental, or health protection or the ability of a facility to operate;

(b) Involve degradation of environmental, safety or health conditions;

(c) Result in serious personnel injury or significant lost workdays; personnel contamination, assimilation, exposure, or significant onsite or offsite contamination of hazardous or radioactive materials in excess of administrative limits but within regulatory limits; or degradation of environmental monitoring equipment necessary to demonstrate compliance;

(d) Result in the violation of safety, environmental, or health administrative limits; or

(e) Involve operational procedural violations, including maintenance and administrative procedures which have the potential to impact the safety, security, environmental or health performance or operation of a facility.

b. Notification. Requirements for oral and documented notification of Reportable Occurrences are as follows:

(1) **Emergencies.** Oral notification to DOE and offsite authorities of emergencies shall be made within 15 minutes or less of categorization. A Notification Report shall be prepared and submitted as soon as practical but, in all cases, within 24 hours of categorization.

(2) **Unusual Occurrences.** Oral notification to DOE on unusual occurrences shall be as soon as sufficient information is obtained to indicate the general nature and extent of the occurrence but, in all cases, within 2 hours of categorization. A Notification Report shall be prepared and submitted within 24 hours of categorization.

(3) **Off-Normal Occurrences.** For off-normal occurrences, oral notification to DOE is not mandatory; however, a Notification Report shall be prepared and submitted within 24 hours of categorization.

[DOE Order 5000.3A, 7]

1.2.2.4.7C4 IMPLEMENTATION REQUIREMENTS.

a. Occurrence Categorization and Notification Process.

(1) The facility staff and operators shall identify and promptly notify the Facility Manager of abnormal events and conditions and record and archive all information pertaining to such occurrences.

(2) Appropriate immediate response(s) shall be taken by contractor operations personnel to stabilize or return the facility/operation to a safe condition.

(3) The Facility Manager shall categorize the occurrence as required in Paragraph 7a of this Order utilizing the facility specific procedures developed in accordance with Paragraph 8d(2) of this Order.

(4) The Facility Manager or his or her designee shall be available at all times to carry out the requirements of this Order.

(5) For oral notification, the Facility Manager shall simultaneously contact the DOE Facility Representative and the HQ EOC through which the DOE Program Manager or his or her designee and any other necessary program staff can be located and direct communications links with the Facility Manager established. The HQ EOC function here is to facilitate communications within line organizations, and to record and archive conversations. The Facility Manager may use the local Field/Site EOC to expedite establishing the direct communication link required above.

(6) The Program Manager or his or her designee shall notify his or her PSO of the occurrence, and, for emergencies, the PSO shall notify the Secretary, the Office of Environment Safety and Health, and, as appropriate, the Office of Nuclear Safety. For all other occurrences; the PSO shall use judgment as to notification of these Departmental elements.

(7) The DOE Facility Representative or his or her designee shall be available at all times to carry out the requirements of this Order.

(8) The DOE Facility Representative shall notify the appropriate Head of the Field Organization of Reportable Occurrences.

(9) During the entire process of notification and reporting, as noted in this Order, the DOE Facility Representative and Program Manager should use the current management chain established for the line organization in providing program direction to the contractor.

(10) The Facility Manager shall prepare and submit the Notification Report (fields 1 through 18 of the Occurrence Report), and distribute it to the DOE Facility Representative and Program Manager within 24 hours of categorization of the occurrence. If the Facility Manager submits the Notification Report by using the computerized DOE Operational Data Base, Paragraph 8c(1) below, then the distribution requirement is automatically satisfied.

b. Occurrence Report and Follow-up Process.

(1) For every Reportable Occurrence, the Facility Manager shall determine and document in the Occurrence Report as soon as practical;

- (a) The significance, nature and extent of the event or condition;**
- (b) The cause(s) of the event or condition, including the root cause(s) as appropriate;**
- (c) The corrective actions to be taken to correct the condition and prevent recurrence.**

(2) Within 10 working days of categorization, the Facility Manager shall submit an Occurrence Report in accordance with subparagraph (6) below. For hard copy reports (i.e., classified reports), the 10-day report shall include any updated information provided by the DOE Facility Representative in accordance with subparagraph (3) below. Complete information required in subparagraph (1) above should be available at that time for the majority of Reportable Occurrences.

(3) The DOE Facility Representative, in consultation with the DOE Program Manager, should provide the Facility manager his or her assessment of the occurrence, and of the initial and proposed corrective actions and follow-up of the contractor and any other actions DOE has taken since the occurrence, in a timely manner for inclusion in the Occurrence Report. If the computerized DOE Operational Data Base is being used, the Facility Representative's comments should be provided via the data base.

(4) The Occurrence Report shall be prepared, signed by the Facility Manager and submitted to the DOE Facility Representative as a final report when the cause of the occurrence has been analyzed, root cause and contributing causes determined, corrective actions determined and scheduled, and lessons-learned identified.

(5) The final Occurrence Report shall then be reviewed and signed by the DOE Facility Representative within 3 working days of receipt and forwarded to the Program Manager for signature acknowledging receipt, when the information required in subparagraph (4) above is provided. The signed report shall be returned to the Facility Manager for distribution, in accordance with subparagraph (6) below, as a final report.

(6) The Occurrence Report (10-day and final) shall be prepared by the Facility Manager and distributed to the Program Manager, the affected program self-assessment group, PSOs, the Heads of all Field Organizations, the DOE Facility Representative, Office of Nuclear Safety (NS-1), Office of Environmental Safety and Health (EH-1), all DOE Management and Operations (M&O) contractors, the Office of Nuclear Safety Policy and Standards (NE-70), the Defense Nuclear Facilities Safety Board (DNFSB), and the Advisory Committee on Nuclear Facility Safety (ACNFS). If the Occurrence Reports (10-day and final) are entered onto the DOE Operational Data Base, Paragraph 8c(1) below, by the Facility Manger, then the distribution requirement is automatically satisfied.

(7) During this entire process, the DOE Facility Representative and the Program Manager shall monitor the Facility Manager's evaluation of the occurrence to ensure acceptability of root cause determinations, generic implications, and corrective action(s) implementation and closeout. They shall also interact with the contractor and Field Organization oversight organizations as necessary and inform and advise their respective management of their findings.

(8) If the DOE Facility Representative or Program Manager identify an unresolved issue regarding actions or determinations on a Reportable Occurrence, the Program Manager shall evaluate the issue to the PSO and, if necessary, the Secretary for resolution and direction.

(9) Contractors shall maintain the Operational Data Base (Paragraph 8c(1) below) up-to-date on the status of Occurrence Report corrective actions. Status reports of all incomplete Occurrence Reports (not final) and incomplete corrective actions shall be available at any time from the Operational Data Base.

c. Utilization of Reportable Occurrence Information.

(1) Operational Data Base. The Office of Nuclear Energy (NE-1) has established and shall maintain an unclassified central DOE operational data base, the Occurrence Reporting and Processing System (ORPS), to contain all unclassified Occurrence Reports to be entered into the DOE Operational Data Base by the Facility Manager. The Occurrence Report documentation and distribution requirements of this Order shall be satisfied by utilization of ORPS, with the exception of those Occurrence Reports containing classified information. The information in the data base shall be available to all Departmental Elements and DOE operating contractors.

(2) Utilization. Contractors for each facility or group of facilities shall collect and disseminate to their personnel the operations information obtained from their facilities and the lessons to be learned from this information. Each Facility Manager should adopt the use of trending and analysis of this information for early indications of deteriorating conditions. Corrective actions should be taken for any identified deteriorating conditions. The Facility Manager should review the DOE Operational Data Base to identify good practices and lessons learned from other facilities that can be used in his/her facility.

d. Procedures.

Program Secretarial Officers (PSOs) shall take action to have procedures established for implementation of the requirements of this Order for facilities under their cognizance. These procedures shall be approved by the PSO and shall include:

- (1) Responsibilities of the contractor, field organization, Headquarters program office, and the HQ Emergency Operations Center (EOC).
- (2) Categorization, notification, and reporting requirements for each facility.

e. Training.

PSOs shall take action to have training programs established for both DOE and contractor personnel in the requirements of this Order for facilities under their cognizance. These training programs shall include:

- (1) Indoctrination in the philosophy of occurrence reporting as outlined in Paragraph 6 of this Order.
- (2) Identification of Reportable Occurrences; their categorization, notification, and associated reporting requirements; analysis, determination of root causes and generic implications; and implementation, tracking and close-out of correction actions.
- (3) Utilization of the DOE Operational Data Base, including the input of occurrence reports and obtaining information from the data base.

[DOE Order 5000.3A, 8]

B. Performance: None specified at this time

C. Interface: None specified at this time

Table F1.2.2.4.8 Function Description: Collect/File Transportation Records

- I. Function ID Number:** 1.2.2.4.8
- II. Function Title:** Collect/File Transportation Records
- III. Function Definition:**

Records and documents are generated that are campaign specific, while OCC operations will generate records that cover the overall program as well as multiple campaigns. All log books, documents, and records prepared are collected and retained to fulfill legal and fiscal requirements. Records collection, filing, and management for Transportation System operations and equipment is a level of effort activity that will run throughout the life of the Transportation System.

IV. Interfaces:

- A. Inputs:** None identified at this time
- B. Outputs:** None identified at this time

V. Requirements:

A. Constraints:

1.2.2.4.8C1 (b) General requirements. To achieve the performance objectives of paragraph (a) of this section, a physical protection system established and maintained, or arranged for, by the licensee shall: ...

(5) Provide for maintenance of a written log by the escorts and communications center personnel for each spent fuel shipment, which will include information describing the shipment and significant events that occur during the shipment, and will be available for review by authorized NRC personnel for a period of at least three years following completion of the shipment.

[10 CFR 73.37]

- B. Performance:** None specified at this time
 - C. Interface:** None specified at this time
-
-

Table F1.2.3 Function Description: Support Waste Transportation Operations

I. Function ID Number: 1.2.3

II. Function Title: Support Waste Transportation Operations

III. Function Definition:

Numerous support activities are provided by the transportation support system to enable the accept and transport functions to be carried out.

IV. Interfaces:

A. Inputs:

1.2.3I1	Unloaded SNF Casks/Transporters/ Documents	From: Function 1.3 / 1.4 / Private Transportation Industry
1.2.3I2	Unloaded CHLW Casks/Transporters/ Documents	From: Function 1.4 / Private Transportation Industry
1.2.3I3	Unloaded DHLW Casks/Transporters/ Documents	From: Function 1.4 / Private Transportation Industry

B. Outputs:

1.2.3O1	Unloaded SNF Casks/Transporters	To: Function 1.1 / 1.3
1.2.3O2	Unloaded CHLW Casks/Transporters	To: Function 1.1
1.2.3O3	Unloaded DHLW Casks/Transporters	To: Function 1.1
1.2.3O4	Ancillary Equipment	To: Function 1.2.1 / Purchaser, Producer

V. Requirements:

A. Constraints: None specified at this time

B. Performance: None specified at this time

C. Interface: None specified at this time

Table F1.2.3.1 Function Description: Plan Transport Operations

I. Function ID Number: 1.2.3.1

II. Function Title: Plan Transport Operations

III. Function Definition:

This function develops, assembles, and distributes campaign and route planning information to the operations management organizations at NWMS receiving facilities and to the affected waste generator facilities. In addition, this information is distributed to the Transportation System organizations responsible for field service, traffic management, maintenance, and others whose work schedules are directly affected by the campaign planning activities. This information covers the deployment status not only of casks and vehicles, but also of ancillary equipment, reconfiguration components (cask baskets), and maintenance and field service resources. An important part of this planning function involves coordinating transportation operations schedules with the waste generators and the repository or MRS receiving facilities. Route planning is coordinated with State and local officials as required.

IV. Interfaces:

A. Inputs:

1.2.3.111	Annual Acceptance Rates	From: Function 1.0
1.2.3.112	Approved Delivery Commitment Schedules	From: Function 1.1
1.2.3.113	Approved DCS Exchange Requests	From: Function 1.1
1.2.3.114	Approved Final Delivery Schedules	From: Function 1.1
1.2.3.115	Evaluation Request	From: Function 1.1

B. Outputs:

1.2.3.101	Evaluation Support	To: Function 1.1
1.2.3.102	Schedules, Plans	To: Function 1.1 / 1.3 / 1.4 / 1.2.2.4.1 / 1.2.3.4 / 1.2.3.5 / 1.2.3.7 / Purchaser, Producer

V. Requirements:

A. Constraints:

1.2.3.1C1 a. Federal Regulations. When offered to the carrier, each shipment of hazardous materials, hazardous substances, or hazardous wastes shall be in compliance with this Order and the applicable safety regulations of the Department of Transportation, and follow the applicable packaging standards of the Nuclear Regulatory Commission (10 CFR 71)

e. Department of Energy as Consignor. When a Department of Energy field organization, rather than a contractor, serves as the actual consignor, independent internal procedures shall be established by the responsible Head of the Field Organization to assure compliance with the standards contained in this Order.

[DOE Order 5480.3, 7]

1.2.3.1C2 OPERATING PROCEDURES

a. Establishment and Maintenance of Procedures. The shipper shall establish and maintain:

(1) Operating procedures adequate to assure that the determinations and controls required by this section are accomplished.

(2) Regular and periodic inspection procedures adequate to assure that the procedures required by paragraph 10a(1), above, are followed.

b. Assumptions as to Unknown Properties. When the isotopic abundance, mass, concentration, degree of irradiation, degree of moderation, or other pertinent property of fissile material in any package is not known, the shipper shall package the fissile material as if the unknown properties have such credible values as will cause the maximum nuclear reactivity. Any special instructions needed to safely open the package are to be made available to the consignee.

[DOE Order 5480.3, 10]

B. Performance: None specified at this time

C. Interface: None specified at this time

Table F1.2.3.1.1 Function Description: Plan Campaigns and Transportation System Operations

- I. Function ID Number:** 1.2.3.1.1
- II. Function Title:** Plan Campaigns and Transportation System Operations
- III. Function Definition:**

This function develops, modifies, assembles, and distributes campaign planning information to the operations management organizations at NWMS receiving facilities and at the affected waste generator facilities. In addition, planning information is distributed to the Transportation System organizations responsible for field service, traffic management, maintenance, and others whose work schedules is directly affected by the campaign planning activities.

On the basis of final delivery schedules, campaign plans are developed and distributed to affected parties that identify shipping schedules, equipment requirements, technical support requirements, operations contingencies, transport mode requirements, and advanced preparations requirements.

Transportation System master plans are developed using campaign plans and equipment maintenance requirements.

Whenever external factors or variances change the existing campaign plans, planning is reinitiated. Revised plans, which reflect the external factor and coordinate with those affected, will be reissued.

IV. Interfaces:

A. Inputs:

1.2.3.1.1I1	Annual Acceptance Rates	From: Function 1.0
1.2.3.1.1I2	Approved Final Delivery Schedules	From: Function 1.1

B. Outputs:

1.2.3.1.1O1	Schedules, Plans	To: Function 1.1 / 1.3 / 1.4 / 1.2.2.4.1 / 1.2.3.4 / 1.2.3.5 / 1.2.3.7 / Purchaser, Producer
-------------	------------------	--

V. Requirements:

A. Constraints:

1.2.3.1.1C1 (b) General requirements. To achieve the performance objectives of paragraph (a) of this section, a physical protection system established and maintained, or arranged for, by the licensee shall: ...

(7) Provide for advance approval by the NRC of the routes used for road and rail shipments of spent fuel, and of any U.S. ports where vessels carrying spent fuel shipments are scheduled to stop.

[10 CFR 73.37]

1.2.3.1.1C2 (b) Except as otherwise permitted in this paragraph and in paragraph (e) of this section, a carrier or any person operating a motor vehicle containing a highway route controlled quantity of Class 7 (radioactive) materials, as defined in Sec. 173.403(1) of this subchapter, shall operate the motor vehicle only over preferred routes. Those routes must be selected by the carrier or that person operating a motor vehicle containing a highway route controlled quantity of radioactive materials to reduce time in transit over the preferred route segment of the trip. An Interstate System bypass or Interstate System beltway around a city, when available, shall be used in place of a preferred route through a city, unless a State routing agency has designated an alternative route.

[49 CFR 177.825]

1.2.3.1.1C3 (2) A motor vehicle may be operated over a route, other than a preferred route, only under the following conditions:

(i) The deviation from the preferred route is necessary to pick up or deliver a highway route controlled quantity of Class 7 (radioactive) materials, to make necessary rest, fuel or motor vehicle repair stops, or because emergency conditions make continued use of the preferred route unsafe or impossible;

(ii) For pickup and delivery not over preferred routes, the route selected must be the shortest-distance route from the pickup location to the nearest preferred route entry location, and the shortest-distance route to the delivery location from the nearest preferred route exit location. Deviation from the shortest-distance pickup or delivery route is authorized if such deviation:

(A) Is based upon the radiological risk minimization criteria of paragraph (a) of this section; and

(B) Does not exceed the shortest-distance pickup or delivery route by more than 25 miles and does not exceed 5 times the length of the shortest-distance pickup or delivery route.

(iii) Deviations from preferred routes, or pickup or delivery routes other than preferred routes, which are necessary for rest, fuel, or motor vehicle repair stops or because of emergency conditions, shall be made in accordance with the radiological risk minimization criteria of paragraph (a) of this section unless, due to emergency conditions, time does not permit use of those criteria.

[49 CFR 177.825(b)]

1.2.3.1.1C4 (c) A carrier (or his agent) who operates a motor vehicle which contains a package of highway route controlled quantity Class 7 (radioactive) materials as defined in Sec. 173.403(l) of this subchapter shall prepare a written route plan and supply a copy before departure to the motor vehicle driver and a copy to the shipper (before departure for exclusive use shipments, or otherwise within fifteen working days following departure). Any variation between the route plan and routes actually used, and the reason for it, shall be reported in an amendment to the route plan delivered to the shipper as soon as practicable but within 30 days following the deviation. The route plan shall contain:

(1) A statement of the origin and destination points, a route selected in compliance with this section, all planned stops, and estimated departure and arrival times; and

(2) Telephone numbers which will access emergency assistance in each State to be entered.

[49 CFR 177.825]

1.2.3.1.1C5 PREMIUM TRANSPORTATION.

a. Premium transportation shall be used only when the additional cost is clearly justified. When premium transportation (including exclusive use of vehicle) is used for shipments weighing 500 pounds or more, a written statement supporting the use of such transportation shall be retained in an appropriate file.

[DOE Order 1540.1, CH-1,8]

1.2.3.1.1C6 SHIPMENT NOTIFICATION POLICY. It is the policy of the DOE, applicable to all contractor shippers, to provide advance written notification on all shipments of unclassified high-level radioactive waste and spent nuclear fuel to the designated representatives to the States through which any such shipments will pass.

[DOE Order 1540.1, CH-II,8]

1.2.3.1.1C7 SHIPMENT CAMPAIGN PLANS.

a. For all Departmental shipments of highway route-controlled quantities of radioactive materials, or like quantities by rail or barge, a shipment plan will be submitted to DP-121 for such shipping campaigns 45 days in advance of such shipments.

b. Single shipments without any expectation of follow-on shipments are exempt from this requirement

c. The shipping plan will include material type, shipping dates, estimate number of shipments, mode of transport, carrier proposed routes, package or cask description, and cargo security arrangements if required. Should any of the shipping plan data be classified submission of the plan should be in complete compliance with applicable Departmental directives on the transmission of such data. Should only a portion of the plan be classified, those portions should be specifically identified.

[DOE Order 1540.1, CH-II,9]

B. Performance: None specified at this time

C. Interface: None specified at this time

Table F1.2.3.1.2 Function Description: Prepare Long Range Plans

I. Function ID Number: 1.2.3.1.2

II. Function Title: Prepare Long Range Plans

III. Function Definition:

Long range (1 - 10 years) plans are developed for pick-up and delivery of purchasers' spent fuel. Strategies are developed based on producer's/purchasers' 5-year delivery commitment schedules and 10-year discharge projections. Estimates of resources including cask fleet size and ancillary equipment by year during the 10-year period are developed.

This function also provides a means for evaluation and proposed implementation of good practices, lessons learned, and enhancements in the Transportation industry and the Transportation System. This evaluation includes trend analysis to determine appropriate corrective actions to prevent incident/event recurrence and to improve the System's effectiveness and efficiency.

IV. Interfaces:

A. Inputs:

1.2.3.1.2I1	Annual Acceptance Rates	From: Function 1.0
1.2.3.1.2I2	Approved Delivery Commitment Schedules	From: Function 1.1
1.2.3.1.2I3	Approved DCS Exchange Requests	From: Function 1.1
1.2.3.1.2I4	Approved Final Delivery Schedules	From: Function 1.1
1.2.3.1.2I5	Evaluation Request	From: Function 1.1

B. Outputs:

1.2.3.1.2O1	Evaluation Support	To: Function 1.1
-------------	--------------------	-------------------------

V. Requirements:

A. Constraints:

1.2.3.1.2C1 IMPLEMENTATION REQUIREMENTS.

c. Utilization of Reportable Occurrence Information.

(2) Utilization. Contractors for each facility or group of facilities shall collect and disseminate to their personnel the operations information obtained from their facilities and the lessons to be learned from this information. Each Facility Manager should adopt the use of trending and analysis of this information for early indications of deteriorating

conditions. Corrective actions should be taken for any identified deteriorating conditions. The Facility Manager should review the DOE Operational Data Base to identify good practices and lessons learned from other facilities that can be used in his/her facility.
[DOE Order 5000.3A, 8]

B. Performance: None specified at this time

C. Interface: None specified at this time

Table F1.2.3.2 Function Description: Conduct Regulatory Compliance Activities

I. Function ID Number: 1.2.3.2

II. Function Title: Conduct Regulatory Compliance Activities

III. Function Definition:

Activities involving interaction with permitting, certification and licensing organizations for the acquisition and maintenance of licenses, certificates, permits and other authorizations of government agencies. Compliance functions also plan and coordinate recertification of NRC casks.

Compliance functions also include activities to maintain conformance with industry and other standards of practice. These various activities necessitate the monitoring of new developments and change in the regulations, laws, standards, and industry practices. This monitoring is also part of the compliance function.

Activities within this function also involve monitoring compliance with the transportation-related part of the DOE standard contract for disposal of spent fuel and HLW.

IV. Interfaces:

A. Inputs: None identified at this time

B. Outputs: None identified at this time

V. Requirements:

A. Constraints:

1.2.3.2C1 Completeness and accuracy of information.

(a) Information provided to the Commission by an applicant for a license or by a licensee or information required by statute or by the Commission's regulations, orders, or license conditions to be maintained by the applicant or the licensee shall be complete and accurate in all material respects.

(b) Each applicant or licensee shall notify the Commission of information identified by the applicant or licensee as having for the regulated activity a significant implication for public health and safety or common defense and security. An applicant or licensee violates this paragraph only if the applicant or licensee fails to notify the Commission of information that the applicant or licensee has identified as having a significant implication for public health and safety or common defense and security. Notification shall be provided to the Administrator of the appropriate Regional Office within two working days of identifying the information. This requirement is not applicable to information which is already required to be provided to the Commission by other reporting or updating requirements.

[10 CFR 71.6a]

1.2.3.2C2 General License: NRC approved package.

(c) This general license applies only to a licensee who: ...

(3) Submits in writing to the Director, Office of Nuclear Material Safety and Safeguards, U.S. Nuclear Regulatory Commission, Washington, DC 20555, prior to the licensee's first use of the package, the licensee's name and license number and the package identification number specified in the package approval.

[10 CFR 71.12]

1.2.3.2C3 Previously approved Type B package.

(b) The NRC will approve modifications to the design and authorized contents of a Type B package previously approved by the NRC, but not designated as B(U) or B(M) in the NRC Certificate of Compliance, provided: (1) The modifications are not significant with respect to the design, operating characteristics, or safe performance of the containment system when the package is subjected to the tests specified in Sections 71.71 and 71.73; and (2) The modification to the package satisfies the requirements of this part.

[10 CFR 71.13]

1.2.3.2C4 Contents of application.

(a) An application for an approval under this part must include, for each proposed packaging design, the following information:

- (1) A package description as required by 71.33;
- (2) A package evaluation as required by 71.35;
- (3) A quality assurance program description as required by 71.37;
- (4) In the case of fissile material, an identification of the proposed fissile class.

(b) Except as provided in 71.13, an application for modification of a package design, whether for modification of the packaging or authorized contents, must include sufficient information to demonstrate that the proposed design satisfies the package standards in effect at the time the application is filed.

[10 CFR 71.31]

1.2.3.2C5 Inspection and tests.

(a) The licensee shall permit the Commission at all reasonable times to inspect the licensed material, packaging, premises, and facilities in which the licensed material or packaging is used, produced, tested, stored, or shipped ...

(b) The licensee shall perform, and permit the Commission to perform, tests as the Commission deems necessary or appropriate for the administration of the regulations in this chapter.

[10 CFR 71.93]

1.2.3.2C6 Reports.

The licensee shall report to the Director, Office of Nuclear Material Safety and Safeguards, U.S. Nuclear Regulatory Commission, Washington, DC 20555, within 30 days:

(a) Any instance in which there is significant reduction in the effectiveness of any authorized packaging during use; and

(b) Details of any defects with safety significance in the packaging after first use, with the means employed to repair the defects and prevent their recurrence.

[10 CFR 71.95]

1.2.3.2C7 Immediate notice of certain hazardous materials incidents.

(a) At the earliest practicable moment, each carrier who transports hazardous materials (including hazardous wastes) shall give notice in accordance with paragraph (b) of this section after each incident that occurs during the course of transportation (including loading, unloading and temporary storage) in which--

(1) As a direct result of hazardous materials--

- (i) A person is killed; or
- (ii) A person receives injuries requiring his or her hospitalization; or
- (iii) Estimated carrier or other property damage exceeds \$50,000; or
- (iv) An evacuation of the general public occurs lasting one or more hours; or
- (v) One or more major transportation arteries or facilities are closed or shut down for one hour or more; or
- (vi) The operational flight pattern or routine of an aircraft is altered; or

(2) Fire, breakage, spillage, or suspected radioactive contamination occurs involving shipment of radioactive material (see also Sections 174.45, 175.45, 176.48, and 177.807 of this subchapter); or

(3) Fire, breakage, spillage, or suspected contamination occurs involving shipment of etiologic agents; or

(4) A situation exists of such a nature (e.g., a continuing danger to life exists at the scene of the incident) that, in the judgment of the carrier, it should be reported to the Department even though it does not meet the criteria of paragraph (a) (1), (2) or (3) of this section.

(b) Each notice required by paragraph (a) of this section shall be given to the Department by telephone (toll-free) on 800-424-8802. Notice involving etiologic agents may be given the Director, Center for Disease Control, U.S. Public Health Service, Atlanta, Ga., Area Code (404) 633-5313, in place of the notice to the Department or (toll call) on 202-267-2675. Each notice must include the following information:

- (1) Name of reporter.
- (2) Name and address of carrier represented by reporter.
- (3) Phone number where reporter can be contacted.
- (4) Date, time, and location of incident.
- (5) The extent of injuries, if any.
- (6) Classification, name, and quantity of hazardous materials involved, if such information is available.
- (7) Type of incident and nature of hazardous material involvement and whether a continuing danger to life exists at the scene.

(c) Each carrier making a report under this section shall also make the report required by Sec. 171.16.

Note: Under 40 CFR 302.6 EPA requires persons in charge of facilities (including transport vehicles, vessels, and aircraft) to report any release of a hazardous substance in a quantity equal to or greater than its reportable quantity, as soon as that person has knowledge of the release, to the U.S. Coast Guard National Response Center at (toll free) 800-424-8802 or (toll) 202-267-2675. [49 CFR 171.15]

1.2.3.2C8 Detailed hazardous materials incident reports.

(a) Each carrier who transports hazardous materials shall report in writing, in duplicate, on DOT Form F 5800.1 (Rev. 6/89) to the Department within 30 days of the date of discovery, each incident that occurs during the course of transportation (including loading, unloading, and temporary storage) in which any of the circumstances set forth in Sec. 171.15(a) occurs or there has been an unintentional release of hazardous materials from a package (including a tank) or any quantity of hazardous waste has been discharged during transportation. If a report pertains to a hazardous waste discharge:

(1) A copy of the hazardous waste manifest for the waste must be attached to the report; and

(2) An estimate of the quantity of the waste removed from the scene, the name and address of the facility to which it was taken, and the manner of disposition of any removed waste must be entered in Section IX of the report form (Form F 5800.1) (Rev. 6/89).

(b) Each carrier making a report under this section shall send the report to the Information Systems Manager, DHM-63, Research and Special Programs Administration, Department of Transportation, Washington, DC 20590-0001; a copy of the report shall be retained, for a period of two years, at the carrier's principal place of business, or at other places as authorized and approved in writing by an agency of the Department of Transportation.

(c) Except as provided in paragraph (d) of this section, the requirements of paragraph (a) of this section do not apply to incidents involving the unintentional release of hazardous materials being transported under the following proper shipping names:

(1) Consumer commodity.

(2) Battery, electric storage, wet, filled with acid or alkali.

(3) Paint and paint related material when shipped in packagings of five gallons or less.

(d) The exceptions to incident reporting provided in paragraph (c) of this section do not apply to:

(1) Incidents required to be reported under Sec. 171.15(a);

(2) Incidents involving transportation aboard aircraft; nor

(3) Incidents involving the transportation of hazardous waste.

Note: A guideline document for assisting in the completion of DOT Form F 5800.1 (Rev. 6/89) may be obtained from the Office of Hazardous Materials Transportation, DHM-51, U.S. Department of Transportation, Washington, DC 20590-0001.

[49 CFR 171.16]

1.2.3.2C9 Routing and training requirements for Class 7 (radioactive) materials.

(a) Except as provided in paragraph (b) of this section, a carrier or any person operating a motor vehicle that contains a Class 7 (radioactive) material for which placarding is required under part 172 of this subchapter shall--

(1) Ensure that the motor vehicle is operated on routes that minimize radiological risk;

(2) In determining the level of radiological risk, consider available information on accident rates, transit time, population density and activities, and the time of day and the day of week during which transportation will occur; and

(3) Tell the driver which route to take and that the motor vehicle contains Class 7 (radioactive) materials.

The requirements of this paragraph do not apply when there is only one practicable highway route available, considering operating necessity and safety, or when the routing of the motor vehicle is subject to paragraph (b) of this section.

[49 CFR 177.825]

1.2.3.2C10 (b) Except as otherwise permitted in this paragraph and in paragraph (e) of this section, a carrier or any person operating a motor vehicle containing a highway route controlled quantity of Class 7 (radioactive) materials, as defined in Sec. 173.403(l) of this subchapter, shall operate the motor vehicle only over preferred routes. Those routes must be selected by the carrier or that person operating a motor vehicle containing a highway route controlled quantity of radioactive materials to reduce time in transit over the preferred route segment of the trip. An Interstate System bypass or Interstate System beltway around a city, when available, shall be used in place of a preferred route through a city, unless a State routing agency has designated an alternative route.

[49 CFR 177.825]

1.2.3.2C11 (c) A carrier (or his agent) who operates a motor vehicle which contains a package of highway route controlled quantity Class 7 (radioactive) materials as defined in Sec. 173.403(l) of this subchapter shall prepare a written route plan and supply a copy before departure to the motor vehicle driver and a copy to the shipper (before departure for exclusive use shipments, or otherwise within fifteen working days following departure). Any variation between the route plan and routes actually used, and the reason for it, shall be reported in an amendment to the route plan delivered to the shipper as soon as practicable but within 30 days following the deviation. The route plan shall contain:

- (1) A statement of the origin and destination points, a route selected in compliance with this section, all planned stops, and estimated departure and arrival times; and
- (2) Telephone numbers which will access emergency assistance in each State to be entered.

[49 CFR 177.825]

1.2.3.2C12 IMPLEMENTATION REQUIREMENTS.

b. Occurrence Report and Follow-up Process.

(1) For every Reportable Occurrence, the Facility Manager shall determine and document in the Occurrence Report as soon as practical;

- (a) The significance, nature and extent of the event or condition;
- (b) The cause(s) of the event or condition, including the root cause(s) as appropriate;
- (c) The corrective actions to be taken to correct the condition and prevent recurrence.

(2) Within 10 working days of categorization, the Facility Manager shall submit an Occurrence Report in accordance with subparagraph (6) below. For hard copy reports (i.e., classified reports), the 10-day report shall include any updated information provided by the DOE Facility Representative in accordance with subparagraph (3) below. Complete information required in subparagraph (1) above should be available at that time for the majority of Reportable Occurrences.

(3) The DOE Facility Representative, in consultation with the DOE Program Manager, should provide the Facility manager his or her assessment of the occurrence, and of the initial and proposed corrective actions and follow-up of the contractor and any other actions DOE has taken since the occurrence, in a timely manner for inclusion in the Occurrence Report. If the computerized DOE Operational Data Base is being used, the Facility Representative's comments should be provided via the data base.

(4) The Occurrence Report shall be prepared, signed by the Facility Manager and submitted to the DOE Facility Representative as a final report when the cause of the occurrence has been analyzed, root cause and contributing causes determined, corrective actions determined and scheduled, and lessons-learned identified.

(5) The final Occurrence Report shall then be reviewed and signed by the DOE Facility Representative within 3 working days of receipt and forwarded to the Program Manager for signature acknowledging receipt, when the information required in subparagraph (4) above is provided. The signed report shall be returned to the Facility Manager for distribution, in accordance with subparagraph (6) below, as a final report.

(6) The Occurrence Report (10-day and final) shall be prepared by the Facility Manager and distributed to the Program Manager, the affected program self-assessment group, PSOs, the Heads of all Field Organizations, the DOE Facility Representative, Office of Nuclear Safety (NS-1), Office of Environmental Safety and Health (EH-1), all DOE Management and Operations (M&O) contractors, the Office of Nuclear Safety Policy and Standards (NE-70), the Defense Nuclear Facilities Safety Board (DNFSB), and the Advisory Committee on Nuclear Facility Safety (ACNFS). If the Occurrence Reports (10-day and final) are entered onto the DOE Operational Data Base, Paragraph 8c(1) below, by the Facility Manager, then the distribution requirement is automatically satisfied.

(7) During this entire process, the DOE Facility Representative and the Program Manager shall monitor the Facility Manager's evaluation of the occurrence to ensure acceptability of root cause determinations, generic implications, and corrective action(s) implementation and closeout. They shall also interact with the contractor and Field Organization oversight organizations as necessary and inform and advise their respective management of their findings.

(8) If the DOE Facility Representative or Program Manager identify an unresolved issue regarding actions or determinations on a Reportable Occurrence, the Program Manager shall evaluate the issue to the PSO and, if necessary, the Secretary for resolution and direction.

(9) Contractors shall maintain the Operational Data Base (Paragraph 8c(1) below) up-to-date on the status of Occurrence Report corrective actions. Status reports of all incomplete Occurrence Reports (not final) and incomplete corrective actions shall be available at any time from the Operational Data Base.

[DOE Order 5000.3A, 8]

1.2.3.2C13 OCCURRENCE CATEGORIZATION, NOTIFICATION AND REPORTING REQUIREMENTS.

Reportable Occurrences shall be categorized and notifications made and reports prepared as described in this Order. Categorization of occurrences by their seriousness is required in order to ensure that the urgency of notification is readily identifiable and that the more serious occurrences are highlighted to management. Attachment 1 to this Order, CATEGORIZATION OF REPORTABLE OCCURRENCES, shall be used to establish facility specific reporting requirements, and their categorizations. Attachment 1 provides a minimum set of standards necessary to allow specific sites/facilities to develop specific Reportable Occurrences applicable to their operations which reflect the DOE-desired degree of significance in categorizations ...

c. Follow-up Notification. In addition to the initial oral notifications required in Paragraph 7b, follow-up oral notification shall also be made to DOE for any of the following:

- (1) Any further degradation in the level of safety of the facility or other worsening conditions, including those that require the declaration of any of the emergency action levels, if such a declaration has not been previously made;
- (2) Any change from one emergency action level or category to another; or
- (3) Termination of an emergency.

d. Occurrence Report Preparation. An Occurrence Report shall be prepared for all Reportable Occurrences, according to the instructions provided in Attachment II, INSTRUCTIONS FOR COMPLETING AN OCCURRENCE REPORT. The submission of Occurrence Report information is required as follows:

- (1) The Notification Report shall be prepared as required in Paragraphs 7b and 8a(10) of this Order;
- (2) Within 10 working days of categorization, the contractor shall submit an Occurrence Report utilizing the information available at that time;
- (3) The Occurrence Report shall be updated when significant new information is available; and

(4) The final Occurrence Report shall be prepared and distributed by the contractor in accordance with this Order when the cause of the occurrences has been analyzed, root cause and contributing causes determined, corrective actions determined and scheduled, and lessons learned identified.

[DOE Order 5000.3A, 7]

B. Performance: None specified at this time

C. Interface: None specified at this time

Table F1.2.3.2.1 Function Description: Monitor Compliance with Applicable Regulatory Requirements

I. Function ID Number: 1.2.3.2.1

II. Function Title: Monitor Compliance with Applicable Regulatory Requirements

III. Function Definition:

The Transportation System is monitored for compliance with regulatory requirements to identify items of noncompliance and changes to the Transportation System are recommended to ensure the necessary corrective actions.

IV. Interfaces:

A. Inputs: None identified at this time

B. Outputs: None identified at this time

V. Requirements:

A. Constraints: None specified at this time

B. Performance: None specified at this time

C. Interface: None specified at this time

Table F1.2.3.2.2 Function Description: Monitor Changes in Regulatory Requirements and Standards

I. Function ID Number: 1.2.3.2.2

II. Function Title: Monitor Changes in Regulatory Requirements and Standards

III. Function Definition:

Regulatory requirements and standards are monitored to identify changes that may impact the Transportation System. The impact of the changes on the Transportation System are assessed and necessary changes to the Transportation System are recommended.

IV. Interfaces:

A. Inputs: None identified at this time

B. Outputs: None identified at this time

V. Requirements:

A. Constraints:

B. Performance: None specified at this time

C. Interface: None specified at this time

Table F1.2.3.2.3 Function Description: Notify Other Functions of Changes in Requirements

I. Function ID Number: 1.2.3.2.3

II. Function Title: Notify Other Functions of Changes in Requirements

III. Function Definition:

This function utilizes the identified changes from the "Monitor Changes in Regulatory Requirements and Standards" function and notifies other functions of the changes.

IV. Interfaces:

A. Inputs: None identified at this time

B. Outputs: None identified at this time

V. Requirements:

A. Constraints: None specified at this time

B. Performance: None specified at this time

C. Interface: None specified at this time

Table F1.2.3.2.4 Function Description: Monitor NRC Certificates of Compliance / other Permits and Licenses

I. Function ID Number: 1.2.3.2.4

II. Function Title: Monitor NRC Certificates of Compliance / other Permits and Licenses

III. Function Definition:

Monitor the status of NRC Certificates of Compliance and other Permits and Licenses appropriate to the Transportation System to ensure that they are current and provides documentation to the appropriate authorizing agency for necessary renewals.

IV. Interfaces:

A. Inputs: None identified at this time

B. Outputs: None identified at this time

V. Requirements:

A. Constraints: None specified at this time

B. Performance: None specified at this time

C. Interface: None specified at this time

Table F1.2.3.3 Function Description: Manage Transportation System

I. Function ID Number: 1.2.3.3

II. Function Title: Manage Transportation System

III. Function Definition:

Manage the Transportation System, including planning, directing, controlling, reviewing, reporting, coordinating, and budgeting. There are certain other management-related functions that are closely monitored to ensure smooth, continued operation of the system, such as finance and accounting, personnel, and QA.

IV. Interfaces:

A. Inputs: None identified at this time

B. Outputs: None identified at this time

V. Requirements:

A. Constraints: None specified at this time

B. Performance: None specified at this time

C. Interface: None specified at this time

Table F1.2.3.3.1 Function Description: Protect Environment, Facilities and Workers

I. Function ID Number: 1.2.3.3.1

II. Function Title: Protect Environment, Facilities and Workers

III. Function Definition:

Manages environmental protection, occupational safety, fire protection, industrial hygiene, health physics, occupational medicine, process and facilities safety, nuclear safety, emergency

preparedness, QA, and radioactive and hazardous waste in compliance with applicable Federal and State regulatory requirements and DOE Orders. Applicable State regulations must be evaluated as facilities are sited and related operations at those sites are defined.

IV. Interfaces:

- A. Inputs:** None identified at this time
- B. Outputs:** None identified at this time

V. Requirements:

- A. Constraints:** None specified at this time
 - B. Performance:** None specified at this time
 - C. Interface:** None specified at this time
-
-

Table F1.2.3.3.1.1 Function Description: Protect Environment

- I. Function ID Number:** 1.2.3.3.1.1
- II. Function Title:** Protect Environment
- III. Function Definition:**

This function ensures the protection of the environment by monitoring and controlling releases of radioactive and other contaminants into the air, soil, and water from Transportation System facilities as defined in regulatory requirements. This function also develops emergency preparedness, including fire protection, measures to be taken to reduce the impact of an emergency (i.e., fire) on the environment.

IV. Interfaces:

- A. Inputs:** None identified at this time
- B. Outputs:** None identified at this time

V. Requirements:

- A. Constraints:** None specified at this time
 - B. Performance:** None specified at this time
 - C. Interface:** None specified at this time
-
-

Table F1.2.3.3.1.2 Function Description: Provide Security

- I. Function ID Number:** 1.2.3.3.1.2
 - II. Function Title:** Provide Security
 - III. Function Definition:**
Provides physical security protection to prevent radiological sabotage and destruction of Transportation System facilities and equipment.
 - IV. Interfaces:**
 - A. Inputs:** None identified at this time
 - B. Outputs:** None identified at this time
 - V. Requirements:**
 - A. Constraints:** None specified at this time
 - B. Performance:** None specified at this time
 - C. Interface:** None specified at this time
-
-

Table F1.2.3.3.1.3 Function Description: Protect Workers

- I. Function ID Number:** 1.2.3.3.1.3
 - II. Function Title:** Protect Workers
 - III. Function Definition:**
Provides radiation protection, occupational safety, and industrial hygiene for Transportation System staff in compliance with regulatory requirements.
 - IV. Interfaces:**
 - A. Inputs:** None identified at this time
 - B. Outputs:** None identified at this time
 - V. Requirements:**
 - A. Constraints:** None specified at this time
 - B. Performance:** None specified at this time
 - C. Interface:** None specified at this time
-
-

Table F1.2.3.3.2 Function Description: Administer General Support Services

I. Function ID Number: 1.2.3.3.2

II. Function Title: Administer General Support Services

III. Function Definition:

Provides the support services of records management, engineering support, training, procurement, financial accounting, public information, and human resources.

IV. Interfaces:

A. Inputs: None identified at this time

B. Outputs: None identified at this time

V. Requirements:

A. Constraints: None specified at this time

B. Performance: None specified at this time

C. Interface: None specified at this time

Table F1.2.3.3.2.1 Function Description: Manage Information

I. Function ID Number: 1.2.3.3.2.1

II. Function Title: Manage Information

III. Function Definition:

Acquire and store in a readily retrievable manner data, drawings, descriptions, reports, and analyses, quality records, etc., needed to support (1) traffic planning, (2) cask fleet management, (3) cask maintenance activities, (4) cask and facility licensing activities, and (5) maintenance of radiation records and other activities. The information will need to be stored in many different, easily retrievable formats, depending on the nature and quantity of the data and on the needs of users.

The information to be acquired includes Certificate of Compliance (CoC) data, licensing data, as-built cask facility drawings and quality records, waste generator interface description information, state interface and requirements data, federal and state legislative data, shipping records, maintenance and repair records, accountability records (as required), health physics records, operations plans data, and data and information on cask system current configuration, location, maintenance status, etc.

IV. Interfaces:

A. Inputs: None identified at this time

B. Outputs: None identified at this time

V. Requirements:

A. Constraints:

1.2.3.3.2.1C1 Maintenance and inspection of records

(a) Each individual, corporation, partnership, or other entity subject to the regulations in this part must prepare and maintain records necessary to accomplish the purposes of this part, specifically -

- (1) Retain evaluations of all deviations and failures to comply for a minimum of five years after the date of the evaluation;
- (2) Suppliers of basic components must retain any notifications sent to purchasers and affected licensees for a minimum of five years after the date of the notification.
- (3) Suppliers of basic components must retain a record of the purchasers of basic components for 10 years after delivery of the basic component or service associated with a basic component.

(b) Each individual, corporation, partnership, or other entity subject to the regulations in this part must afford the Commission, at all reasonable times, the opportunity to inspect records pertaining to basic components that relate to the discovery, evaluation, and reporting of deviations, failures to comply and defects, including any advice given to purchasers or licensees on the placement, erection, installation, operation, maintenance, modification, or inspection of a basic component.

[10 CFR 21.51]

1.2.3.3.2.1C2 Communications and records.

(b) Each record required by this part must be legible throughout the retention period specified by each Commission regulation. The record may be the original or a reproduced copy or a microform provided that the copy or microform is authenticated by authorized personnel and that the microform is capable of producing a clear copy throughout the required retention period.

The record may also be stored in electronic media with the capability for producing legible, accurate, and complete records during the required retention period. Records such as letters, drawings, specifications, must include all pertinent information such as stamps, initials, and signatures. The licensee shall maintain adequate safeguards against tampering with and loss of records.

[10 CFR 71.1]

1.2.3.3.2.1C3 General License: NRC approved package.

(c) This general license applies only to a licensee who: ...

- (1) Has a copy of the specific license, certificate of compliance, or other approval of the package and has the drawings and other documents referenced in the approval relating to the use and maintenance of the packaging and to the actions to be taken prior to shipment.

[10 CFR 71.12]

1.2.3.3.2.1C4 (b) General requirements. To achieve the performance objectives of paragraph (a) of this section, a physical protection system established and maintained, or arranged for, by the licensee shall: ...

- (2) Include and retain a copy of current procedures for coping with circumstances that threaten deliberate damage to a spent fuel shipment and with other safeguards emergencies as a record for three years after the close of period for which the licensee possesses the special nuclear material under each license for which the procedures were developed and, if any portion of the procedures is superseded, retain the superseded material for three years after each change.

- (3) Include instructions for each escort and retain a copy of the current instructions as a record for three years after the close of period for which the licensee possesses the special nuclear material under each license that authorizes the activity that requires the

instruction and retain any superseded material for three years after each change. The instructions must direct that, upon detection of the abnormal presence of unauthorized persons, vehicles, or vessels in the vicinity of a spent fuel shipment or upon detection of a deliberately induced situation that has the potential for damaging a spent fuel shipment, the escort will:

- (i) Determine whether or not a threat exists;
- (ii) Assess the extent of the threat, if any;
- (iii) Inform local law enforcement agencies of the threat and request assistance; and
- (iv) Implement the procedures developed in accordance with paragraph (b)(2) of this section ...

(5) Provide for maintenance of a written log by the escorts and communications center personnel for each spent fuel shipment, which will include information describing the shipment and significant events that occur during the shipment, and will be available for review by authorized NRC personnel for a period of at least three years following completion of the shipment.

[10 CFR 73.37]

1.2.3.3.2.1C5 Records.

(a) Each licensee shall maintain for a period of three years after shipment a record of each shipment of licensed material not exempt under 71.10, showing, where applicable:

- (1) Identification of the packaging by model number;
- (2) Verification that there are no significant defects in the packaging, as shipped;
- (3) Volume and identification of coolant;
- (4) Type and quantity of licensed material in each package, and the total quantity of each shipment;
- (5) For each item of irradiated fissile material:
 - (i) Identification by model number and/or serial number;
 - (ii) Irradiation and decay history to the extent appropriate to demonstrate that its nuclear and thermal characteristics comply with license conditions; and
 - (iii) Any abnormal or unusual condition relevant to radiation safety.
- (6) Date of the shipment;
- (7) For Fissile Class III and for Type B packages, any special controls exercised;
- (8) Name and address of the transferee;
- (9) Address to which the shipment was made; and
- (10) Results of the determinations required by 71.87 and by the conditions of the package approval.

(b) The licensee shall make available to the Commission for inspection, upon reasonable notice, all records required by this part. Records are valid only if stamped, initialed, or signed and dated by authorized personnel or otherwise authenticated.

(c) Each licensee shall maintain sufficient written records to furnish evidence of the quality of packaging. The records to be maintained include results of the determinations required by 71.85; design, fabrication, and assembly records; results of reviews, inspections, tests, and audits; results monitoring work performance and materials analyses; and results of maintenance, modification, and repair activities. Inspection, test, and audit records must identify the inspector or data

recorder, the type of observation, the results, the acceptability and the action taken in connection with any deficiencies noted. The records must be retained for three years after the life of the packaging to which they apply.

[10 CFR 71.91]

1.2.3.3.2.1C6 TRANSPORTATION DATA.

a. Shipment Mobility/Accountability Concept (SMAC)....All field organizations will participate in SMAC by providing shipment data unless exempted by the Office of Defense Programs. Those exempted from participation will submit an annual transportation report as prescribed in c. of this section and will provide transportation data as required on an ad hoc basis.

[DOE Order 1540.1, CH-I, 10]

1.2.3.3.2.1C7 IMPLEMENTATION REQUIREMENTS.

c. Utilization of Reportable Occurrence Information.

(2) Utilization. Contractors for each facility or group of facilities shall collect and disseminate to their personnel the operations information obtained from their facilities and the lessons to be learned from this information. Each Facility Manager should adopt the use of trending and analysis of this information for early indications of deteriorating conditions. Corrective actions should be taken for any identified deteriorating conditions. The Facility Manager should review the DOE Operational Data Base to identify good practices and lessons learned from other facilities that can be used in his/her facility.

[DOE Order 5000.3A, 8]

1.2.3.3.2.1C8 OPERATING PROCEDURES⁴

e. Records. The shipper shall maintain for 2 years or more a record of each shipment of fissile material and each shipment of amounts of radioactive material greater than Type A quantities in single packages, showing where applicable:

- (1) Identification of the packaging by model number and the number of the certificate of compliance.
- (2) Details of any significant defects in the packaging, with the means employed to repair the defects and prevent their recurrence.
- (3) Volume and identification of coolant.
- (4) Type and quantity of material in each package, and the total quantity in each shipment.
- (5) For each item or irradiated fissile material:
 - (a) Identification by model number.
 - (b) Irradiation and decay history to the extent appropriate to demonstrate that its nuclear and thermal characteristics comply with appropriate conditions.
 - (c) Any abnormal or unusual condition relevant to radiation safety.
- (6) Date of the shipment.
- (7) For Fissile Class III, any special controls exercised.

⁴ Note that this requirement is inconsistent with 10 CFR 71.91(a) in 1.2.3.3.2.1C5.

- (8) Name and address of the transferee.
- (9) Address to which shipment was made.
- (10) Results of the determination required by paragraphs 10c and 10d, above.
[DOE Order 5480.3, 10]

1.2.3.2.1C9 Quality assurance records.

The licensee shall maintain sufficient written records to describe the activities affecting quality. The records must include the instructions, procedures, and drawings required by Section 71.111 to prescribe quality assurance activities and must include closely related specifications such as required qualifications of personnel, procedures, and equipment. The records must include the instructions or procedures which establish a records retention program that is consistent with applicable regulations and designates factors such as duration, location, and assigned responsibility. The licensee shall retain these records for three years beyond the date when the licensee last engages in the activity for which the quality assurance program was developed. If any portion of the written procedures or instructions is superseded, the licensee shall retain the superseded material for three years after it is superseded.

[10 CFR 71.135]

B. Performance: None specified at this time

C. Interface: None specified at this time

Table F1.2.3.3.2.2 Function Description: Provide Engineering Support

I. Function ID Number: 1.2.3.3.2.2

II. Function Title: Provide Engineering Support

III. Function Definition:

Provides engineering support to the Transportation System for licensing, certification, and equipment acquisition activities for cask systems and facilities as well as for Field Service and Maintenance functions.

IV. Interfaces:

A. Inputs: None identified at this time

B. Outputs: None identified at this time

V. Requirements:

A. Constraints: None specified at this time

B. Performance: None specified at this time

C. Interface: None specified at this time

Table F1.2.3.3.2.3 Function Description: Provide for Human Resources

- I. Function ID Number:** 1.2.3.3.2.3
- II. Function Title:** Provide for Human Resources
- III. Function Definition:**
This continuing function provides the human resources necessary to properly operate the Transportation System.
- IV. Interfaces:**
- A. Inputs:** None identified at this time
- B. Outputs:** None identified at this time
- V. Requirements:**
- A. Constraints:** None specified at this time
- B. Performance:** None specified at this time
- C. Interface:** None specified at this time
-
-

Table F1.2.3.3.2.4 Function Description: Train Workforce

- I. Function ID Number:** 1.2.3.3.2.4
- II. Function Title:** Train Workforce
- III. Function Definition:**
Training conducts the activities to orient staff or enhance their skill level. All personnel are trained to perform their function within the Transportation System. The degree of training depends on the organizational affiliation of the trainee. These affiliations could include (1) transportation operations, (2) subcontractors, (3) waste generators, (4) responders (e.g., FEMA), and (5) other organizations.
- IV. Interfaces:**
- A. Inputs:** None identified at this time
- B. Outputs:** None identified at this time
- V. Requirements:**
- A. Constraints:**
- 1.2.3.3.2.4C1 This requirement intentionally left blank.
- 1.2.3.3.2.4C2 (b) ... a shipment that is not prepared for shipment in accordance with the subchapter may not be offered for transport by air, highway or water. It is the duty of each person who offers hazardous materials for transport to instruct each of his officers, agents and employees having responsibility for preparing hazardous materials for shipment as to the applicable regulations in this subchapter."
- [49 CFR 173.1]*
-

1.2.3.3.2.4C3 (8) Provide for required training, testing, and certification of manufacturing and inspection personnel involved in special processes, such as welding and nondestructive examination, and for the required certification of equipment and procedures used in the performance of special processes.

[DOE Order 5480.3, Ch 9 - (b)]

1.2.3.3.2.4C4 (d) The licensee shall provide for indoctrination and training of personnel performing activities affecting quality as necessary to assure that suitable proficiency is achieved and maintained. The licensee shall review the status and adequacy of the quality assurance program at established intervals. Management of other organizations participating in the quality assurance program shall regularly review the status and adequacy of that part of the quality assurance program which they are executing.

[10 CFR 71.105]

B. Performance:

1.2.3.3.2.4P1 2. DOE shall arrange for, and provide, a cask(s) and all necessary transportation of the SNF and/or HLW from the Purchaser's site to the DOE facility. Such cask(s) shall be furnished sufficiently in advance to accommodate scheduled deliveries. Such cask(s) shall be suitable for use at the Purchaser's site, meet applicable regulatory requirements, and be accompanied by pertinent information including, but not limited to, the following:

(b) Training for Purchaser's personnel in cask handling and loading, as may be necessary;
[10 CFR 961.11, Article IV, B]

C. Interface: None specified at this time

Table F1.2.3.3.2.5 Function Description: Procure/Contract Goods and Services

I. Function ID Number: 1.2.3.3.2.5

II. Function Title: Procure/Contract Goods and Services

III. Function Definition:

Procure cask systems and ancillary equipment, tools, spare parts, and services in order to supply and operate the Transportation System with required resources. Procurement includes both a purchasing activity and a contracting activity and requires technical support from other functions.

IV. Interfaces:

A. Inputs:

1.2.3.3.2.5I1	Casks	From: Private Transportation Industry
1.2.3.3.2.5I2	Vehicles	From: Private Transportation Industry
1.2.3.3.2.5I3	Ancillary Equipment	From: Private Transportation Industry
1.2.3.3.2.5I4	Spare Parts and Consumables	From: Private Transportation Industry
1.2.3.3.2.5I5	Prime Movers, Crew	From: Private Transportation Industry

B. Outputs:

1.2.3.3.2.5O1	Casks	To: Function 1.2.3.7.1
1.2.3.3.2.5O2	Vehicles	To: Function 1.2.3.7.2
1.2.3.3.2.5O3	Ancillary Equipment	To: Function 1.2.3.7.3
1.2.3.3.2.5O4	Spare Parts and Consumables	To: Function 1.2.3.7.4
1.2.3.3.2.5O5	Prime Movers, Crew	To: Function 1.2.3.3.6

V. Requirements:

A. Constraints:

1.2.3.3.2.5C1 This requirement intentionally left blank.

1.2.3.3.2.5C2 OPERATING PROCEDURES

c. Preliminary Determinations.

(1) Prior to the first use of any packaging for the shipment of more than a Type A quantity of radioactive material or fissile materials, such packaging shall be inspected to ascertain that there are no cracks, pinholes, uncontrolled voids, or other defects that could significantly reduce its effectiveness.

(2) Prior to the first use of any packaging for the shipment of more than a Type A quantity of radioactive or fissile materials, where the maximum normal operating pressure will exceed 5 pounds per square inch gauge, the containment vessel shall be tested to assure that it will not leak at an integral pressure 50 percent higher than the maximum normal operating pressure.

(3) Packaging shall be marked conspicuously and durably with its model number. Prior to applying the model number, an inspection shall be made to determine that the packaging has been fabricated in accordance with the approved design.
[DOE Order 5480.3, 10]

1.2.3.3.2.5C3 QUALITY ASSURANCE PROCEDURES FOR THE FABRICATION, ASSEMBLY, AND TESTING OF OFFSITE SHIPPING CONTAINERS.

a. Establishment and Maintenance of Procedures. Each field organization shall require its contractors to establish and to maintain a quality assurance program to:

(1) Assure that the requisite standards of quality are met in the fabrication, assembly, and testing of each package.
[DOE Order 5480.3, 9]

1.2.3.3.2.5C4 Procurement Documents

Each individual, corporation, partnership or other entity subject to the regulations in this part shall assure that each procurement document for a facility, or a basic component issued by him, her or it on or after January 6, 1978 specifies, when applicable, that provisions of 10 CFR Part 21 apply.
[10 CFR 21.31]

B. Performance:

1.2.3.3.2.5P1 2. DOE shall arrange for, and provide, a cask(s) and all necessary transportation of the SNF and/or HLW from the Purchaser's site to the DOE facility. Such cask(s) shall be furnished sufficiently in advance to accommodate scheduled deliveries. Such cask(s) shall be suitable for use at the Purchaser's site, meet applicable regulatory requirements, and be accompanied by pertinent information including, but not limited to, the following:

(a) Written procedures for cask handling and loading, including specifications on Purchaser-furnished canisters for containment of failed fuel;

(b) Training for Purchaser's personnel in cask handling and loading, as may be necessary;

(c) Technical information, special tools, equipment, lifting trunnions, spare parts and consumables needed to use and perform incidental maintenance on the cask(s); and

(d) Sufficient documentation on the equipment supplied by DOE.
[10 CFR 961.11, Article IV, B]

C. Interface:

1.2.3.3.2.5I1 Notification of failure to comply or existence of a defect.

(a) Each individual, corporation, partnership or other entity subject to the regulations in this part shall adopt appropriate procedures to:

(1) Provide for: (i) Evaluating deviations or (ii) informing the licensee or purchaser of the deviation in order that the licensee or purchaser may cause the deviation to be evaluated unless the deviation has been corrected; and

(2) Assure that a director or responsible officer is informed if the construction or operation of a facility, or activity, or a basic component supplied for such facility or activity: (i) Fails to comply with the Atomic Energy Act of 1954, as amended, or any applicable rule, regulation, order or license of the Commission relating to a substantial safety hazard, or (ii) Contains a defect. The effective date of this paragraph has been deferred until January 6, 1978.

(b) (1) A director or responsible officer subject to the regulations of this part or a designated person shall notify the Commission when he obtains information reasonably indicating a failure to comply or a defect affecting (i) the construction or operation of a facility or an activity within the United States that is subject to the licensing requirements under Parts 30, 40, 50, 60, 61, 70, 71, or 72 of this chapter and that is within his organization's responsibility or (ii) a basic component that is within his organization's responsibility and is supplied for a facility or an activity within the United States that is subject to the licensing requirements under Parts 30, 40, 50, 60, 61, 70, 71, or 72 of this chapter. The above notification is not required if such individual has actual knowledge that the Commission has been adequately informed of such defect or such failure to comply.

(2) Initial notification required by this paragraph must be made within 2 days following receipt of the information. Notification must be made to the Director, Office of Nuclear Reactor Regulation, or Director, Office of Nuclear Material Safety and Safeguards, as appropriate, U.S. Nuclear Regulatory Commission, Washington, DC 20555, or to the Administrator of a Regional Office. If initial notification is by means other than written communication, a written report must be submitted to the appropriate Office within 5 days after the information is obtained. Three copies of each report must be submitted to the Director, Office of Nuclear Reactor Regulation, or Director, Office of Nuclear Material Safety and Safeguards, as appropriate.

(3) The written report required by this paragraph shall include, but need not be limited to, the following information, to the extent known: (i) Name and address of the individual or individuals informing the Commission. (ii) Identification of the facility, the activity, or the basic component supplied for such facility or such activity within the United States which fails to comply or contains a defect. (iii) Identification of the firm constructing the facility or supplying the basic component which fails to comply or contains a defect. (iv) Nature of the defect or failure to comply and the safety hazard which is created or could be created by such defect or failure to comply. (v) The date on which the information of such defect or failure to comply was obtained. (vi) In the case of a basic component which contains a defect or fails to comply, the number and location of all such components in use at, supplied for, or being supplied for one or more facilities or activities subject to the regulations in this part. (vii) The corrective action which has been, is being, or will be taken; the name of the individual or organization responsible for the action; and the length of time that has been or will be taken to complete the action. (viii) Any advice related to the defect or failure to comply about the facility, activity, or basic component that has been, is being, or will be given to purchasers or licensees.

(4) The director or responsible officer may authorize an individual to provide the notification required by this paragraph, provided that, this shall not relieve the director or responsible officer of his or her responsibility under this paragraph.

(c) Individuals subject to paragraph (b) of this section may be required by the Commission to supply additional information related to the defect or failure to comply.

[10 CFR 21.21]

1.2.3.3.2.5I2 Same as 1.2.3.3.2.5I1 above

1.2.3.3.2.513 Same as 1.2.3.3.2.511 above

1.2.3.3.2.514 Same as 1.2.3.3.2.511 above

1.2.3.3.2.515 None specified at this time

1.2.3.3.2.501 None specified at this time

1.2.3.3.2.502 None specified at this time

1.2.3.3.2.503 None specified at this time

1.2.3.3.2.504 None specified at this time

1.2.3.3.2.505 None specified at this time

Table F1.2.3.3.2.6 Function Description: Inform Public

I. Function ID Number: 1.2.3.3.2.6

II. Function Title: Inform Public

III. Function Definition:

This function supports the NWMS interactions with all public and private organizations external to the DOE systems that are interested in matters which would impact the operating transportation system. The functions that must be carried out include:

1. Support of the NWMS interactions with outside organizations including States with respect to routing issues,
2. Development of transport operations-related information as requested,
3. Support of NWMS international programs,
4. Maintenance of Transportation System policies and plans for external distribution as requested,
5. Support of NWMS management in DOE national energy policy activity,
6. Monitoring legislative, and legal activities that impact Transportation System,
7. Implementing informational plans and developing materials, and
8. Support NWMS by providing media material and a speaker's bureau.

This function includes policy development activities to ensure that the Transportation System works in concert with other DOE organizations and within the guidelines and requirements of the NWPA and its amendments.

IV. Interfaces:

A. Inputs: None identified at this time

B. Outputs: None identified at this time

V. Requirements:

A. Constraints: None specified at this time

B. Performance: None specified at this time

C. Interface: None specified at this time

Table F1.2.3.3.2.7 Function Description: Conduct Financial and Accounting Services

I. Function ID Number: 1.2.3.3.2.7

II. Function Title: Conduct Financial and Accounting Services

III. Function Definition:

This continuing function provides financial and accounting services for the Transportation System. This also includes contracting for annual auditing services by outside organizations.

IV. Interfaces:

A. Inputs: None identified at this time

B. Outputs: None identified at this time

V. Requirements:

A. Constraints: None specified at this time

B. Performance: None specified at this time

C. Interface: None specified at this time

Table F1.2.3.3.3 Function Description: Manage Transportation System Waste

- I. Function ID Number:** 1.2.3.3.3
- II. Function Title:** Manage Transportation System Waste
- III. Function Definition:**

Manage Transportation System wastes in accordance with regulatory requirements and DOE Orders. These wastes are categorized as: (1) low-level radioactive, nonhazardous wastes; (2) high-level radioactive, nonhazardous wastes; (3) hazardous, radioactive wastes; (4) hazardous, nonradioactive wastes; and (5) nonradioactive, nonhazardous wastes. These wastes may include, but are not limited to, radioactive liquids from cask cleaning and decontamination, radioactively contaminated tools, out-of-service casks, and rubber tires and oil from transporters and ancillary equipment.

The majority of the waste generated by the transport system will be associated with cask operations. Each waste stream that the Transportation System is responsible for will be monitored for activity and characterized by placing it into one of the following categories:

1. Hazardous, radioactive wastes,
2. Nonradioactive, nonhazardous wastes,
3. Hazardous, nonradioactive wastes,
4. Low-level radioactive, nonhazardous waste (LLW), or
5. High-level radioactive, nonhazardous wastes (HLW).

Hazardous wastes are those that are defined as hazardous by the Toxic Substance Control Act (TSCA) and/or the Resources Conservation and Recovery Act (RCRA). These acts specifically exclude radioactive emissions from their list of hazardous wastes; instead, they place wastes having such characteristics in a separate radioactive category. Thus, high-level radioactive wastes do not necessarily fall into the "hazardous" category, but rather the "radioactive" category, even though they are hazardous.

The waste in the above categories can be in a liquid or solid form. All liquid wastes that are potentially contaminated will be processed and converted to a solid form prior to disposal. No radioactive waste will be disposed of at any Transportation System-operated site.

The Transportation System will provide centralized control and monitoring of all cask system decontamination activities and is expected to provide for control, monitoring, collection, and treatment of all other Transportation System radioactive wastes. The majority of the Transportation System wastes are expected to be LLW. These wastes will be package appropriately and sent off-site for ultimate disposal by an approved method.

IV. Interfaces:

- A. Inputs:** None identified at this time
- B. Outputs:** None identified at this time

V. Requirements:

- A. Constraints:** None specified at this time
- B. Performance:** None specified at this time
- C. Interface:** None specified at this time
-
-

Table F1.2.3.3.4 Function Description: Maintain Operating Facilities

- I. Function ID Number:** 1.2.3.3.4
- II. Function Title:** Maintain Operating Facilities
- III. Function Definition:**

The Transportation System will employ a number of facilities that are essential to the operations of the system. During normal operation, these facilities will require maintenance so that they can continue to perform their assigned functions. Also included within this function is the maintenance of installed equipment within the facility which is essential to the operations of the Transportation System. Facility modifications and upgrades are also included in the "Maintain Operating Facilities" function.

- IV. Interfaces:**
 - A. Inputs:** None identified at this time
 - B. Outputs:** None identified at this time
 - V. Requirements:**
 - A. Constraints:** None specified at this time
 - B. Performance:** None specified at this time
 - C. Interface:** None specified at this time
-
-

Table F1.2.3.3.5 Function Description: Administer Quality Assurance

- I. Function ID Number:** 1.2.3.3.5
- II. Function Title:** Administer Quality Assurance
- III. Function Definition:**

Establishes and implements an effective management system for the Transportation System that complies with DOE and regulatory requirements. The management controls imposed will be structured to meet programmatic needs; that is, the controls will be graded to meet the requirements depending on the importance of the item or task activity to safety, transportation, or other program objectives.

- IV. Interfaces:**
 - A. Inputs:** None identified at this time
 - B. Outputs:** None identified at this time
 - V. Requirements:**
 - A. Constraints:** None specified at this time
-

B. Performance: None specified at this time

C. Interface: None specified at this time

Table F1.2.3.3.6 Function Description: Direct Operations of Transportation System

I. Function ID Number: 1.2.3.3.6

II. Function Title: Direct Operations of Transportation System

III. Function Definition:

This function directs the operations of the Transportation System, by managing and controlling resources of the "Accept Waste for Transportation," "Ship Waste," and "Support Waste Transportation Operations" functions in the Transportation System. This direction is determined by inputs from the progress and status provided from other functions.

IV. Interfaces:

A. Inputs: None identified at this time

B. Outputs: None identified at this time

V. Requirements:

A. Constraints: None specified at this time

B. Performance: None specified at this time

C. Interface: None specified at this time

Table F1.2.3.4 Function Description: Maintain Cask System

I. Function ID Number: 1.2.3.4

II. Function Title: Maintain Cask System

III. Function Definition:

Maintain cask system ancillary and related equipment, including vehicles, in accordance with regulatory and design requirements by providing routine inspections and maintenance, conduct annual/periodic tests and inspections and required maintenance, and repair or replace components as required. These activities may be conducted at the maintenance facility, at the purchaser/producer site or in-transit as appropriate.

IV. Interfaces:

A. Inputs:

1.2.3.411	Spare Parts and Consumables	From: Function 1.2.3.7
1.2.3.412	Required Repair Findings	From: Function 1.2.1.3
1.2.3.413	Vehicle Needing Repair	From: Function 1.2.2.1.1
1.2.3.414	Schedules, Plans	From: Function 1.2.3.1 / 1.2.3.1.1

B. Outputs: None identified at this time

V. Requirements:

A. Constraints:

1.2.3.4C1 Handling, storage, and shipping control.

The licensee shall establish measures to control, in accordance with instructions, the handling, storage, shipping, cleaning, and preservation of materials and equipment to be used in packaging to prevent damage or deterioration. When necessary for particular products, special protective environments, such as inert gas atmosphere, and specific moisture content and temperature levels must be specified and provided.

[10 CFR 71.127]

B. Performance:

1.2.3.4P1 2. DOE shall arrange for, and provide, a cask(s) and all necessary transportation of the SNF and/or HLW from the Purchaser's site to the DOE facility. Such cask(s) shall be furnished sufficiently in advance to accommodate scheduled deliveries. Such cask(s) shall be suitable for use at the Purchaser's site, meet applicable regulatory requirements, and be accompanied by pertinent information including, but not limited to, the following:

(c) Technical information, special tools, equipment, lifting trunnions, spare parts and consumables needed to use and perform incidental maintenance on the cask(s);

[10 CFR 961.11, Article IV, B]

C. Interface: None specified at this time

Table F1.2.3.4.1 Function Description: Maintain Casks

I. Function ID Number: 1.2.3.4.1

II. Function Title: Maintain Casks

III. Function Definition:

Repair, modify, maintain, and reconfigure casks as documented in a work order or a maintenance schedule. The repair, modification, maintenance, or reconfiguration is performed in accordance with QA requirements.

Reconfiguration of casks may be required in order to accept the next scheduled waste type. Reconfiguration can vary from changing inserts in spent fuel baskets to allow for the shipment of different lengths of fuel to a complete basket changeout to permit the movement of a different type of waste (e.g., canister fuel).

IV. Interfaces:

- A. Inputs:** None identified at this time
B. Outputs: None identified at this time

V. Requirements:

A. Constraints:

1.2.3.4.1C1 General License: NRC approved package.

(c) This general license applies only to a licensee who:

(1) Has a copy of the specific license, certificate of compliance, or other approval of the package and has the drawings and other documents referenced in the approval relating to the use and maintenance of the packaging and to the actions to be taken prior to shipment;

(2) Complies with the terms and conditions of the license, certificate, or other approval, as applicable, and the applicable requirements of Subparts A, G, and H of this part; ...
[10 CFR 71.12]

1.2.3.4.1C2 Inspections and tests.

(b) The licensee shall perform, and permit the Commission to perform, tests as the Commission deems necessary or appropriate for the administration of the regulations in this chapter.

[10 CFR 71.93]

1.2.3.4.1C3 Provide for a program of routine maintenance inspection and where necessary, retesting to assure that all reusable containers used by DOE continue to meet the applicable design standards.

[DOE Order 5480.3, 9, b(7)]

B. Performance:

1.2.3.4.1P1 (c) The Purchaser shall be responsible for incidental maintenance, protection and preservation of any and all shipping casks furnished to the Purchaser by DOE for the performance of this contract. The Purchaser shall be liable for any loss of or damage to such DOE-furnished property, and for expenses incidental to such loss or damage while such casks are in the possession and control of the Purchaser except as otherwise provided for hereunder. Routine cask maintenance, such as scheduled overhauls, shall not be the responsibility of the Purchaser.

[10 CFR 961.11 Article IV, A, 2]

C. Interface: None specified at this time

Table F1.2.3.4.2 Function Description: Service and Maintain Vehicles

I. Function ID Number: 1.2.3.4.2

II. Function Title: Service and Maintain Vehicles

III. Function Definition:

Repair, modify, and maintain vehicles, including railcar, trailers, and tractors.

IV. Interfaces:

A. Inputs: None identified at this time

B. Outputs: None identified at this time

V. Requirements:

A. Constraints: None specified at this time

B. Performance: None specified at this time

C. Interface: None specified at this time

Table F1.2.3.4.3 Function Description: Service and Maintain Ancillary Equipment

I. Function ID Number: 1.2.3.4.3

II. Function Title: Service and Maintain Ancillary Equipment

III. Function Definition:

Repair, modify, and maintain ancillary equipment in accordance with QA requirements.

IV. Interfaces:

A. Inputs: None identified at this time

B. Outputs: None identified at this time

V. Requirements:

A. Constraints: None specified at this time

B. Performance: None specified at this time

C. Interface: None specified at this time

Table F1.2.3.5 Function Description: Conduct Field Operations

I. Function ID Number: 1.2.3.5

II. Function Title: Conduct Field Operations

III. Function Definition:

Support purchaser/producer in shipment preparations and cask loading, including training, equipment readiness, loading observation, documentation preparation. Support intermodal planning and execution. Support MRS and Repository by training and technical assistance. Support Transportation Operations in incident recovery, emergency response support, and technical assistance. Support Waste Acceptance as requested by training and observation.

IV. Interfaces:

A. Inputs:

1.2.3.511 Schedules, Plans From: Function 1.2.3.1 / 1.2.3.1.1

B. Outputs: None identified at this time

V. Requirements:

A. Constraints: None specified at this time

B. Performance: None specified at this time

C. Interface: None specified at this time

Table F1.2.3.5.1 Function Description: Support Waste Acceptance

I. Function ID Number: 1.2.3.5.1

II. Function Title: Support Waste Acceptance

III. Function Definition:

Provide support for cask loading operations. This function provides the resources to fulfill the needs of waste acceptance including Conduct site training, review, modify and concur with cask operating procedures, and verification of readiness to initiate a campaign; Provide assistance as requested to the producer or purchaser in cask handling and loading, identifying site-specific equipment and supplies needed in the shipping campaign, monitoring carrier performance at the site; Provide technical support to the "Accept Loaded Cask for Transportation" function, and accept the cask for transportation.

A major function of Field Services is to ensure that personnel involved in operations at origin sites are properly trained and qualified to carry out required tasks. This includes (1) training waste generator personnel as requested and required, (2) any contractor personnel who may be employed in the shipping campaign, and (3) other Field Services personnel. Field Services will consult with waste generators to determine training aids, documentation, manuals, video tapes, and procedures needed and will arrange for classroom and hands-on training of waste generator and contractor personnel at their facility.

The Field Services function will provide technical advice and assistance to waste generators during cask handling, loading, and preparation for shipment and intermodal transfer as necessary. Occasionally, problems may be encountered that require modification of procedures, incidental maintenance, or minor repair to the shipping systems. Minor repairs might require a Field service review of utility actions or, conceivably, require Field Services to accomplish these repairs and/or modifications at the reactor site or other off-site locations.

Field Services, when at the waste generator site, will also ensure that all documentation (e.g., check-off lists, certifications, inspection records, and off-site shipment records) is collected and forwarded to appropriate recipients.

IV. Interfaces:

A. Inputs: None identified at this time

B. Outputs: None identified at this time

V. Requirements:

A. Constraints: None specified at this time

B. Performance:

1.2.3.5.1P1 2. DOE shall arrange for, and provide, a cask(s) and all necessary transportation of the SNF and/or HLW from the Purchaser's site to the DOE facility. Such cask(s) shall be furnished sufficiently in advance to accommodate scheduled deliveries. Such cask(s) shall be suitable for use at the Purchaser's site, meet applicable regulatory requirements, and be accompanied by pertinent information including, but not limited to, the following:

(a) Written procedures for cask handling and loading, including specifications on Purchaser-furnished canisters for containment of failed fuel;

(b) Training for Purchaser's personnel in cask handling and loading, as may be necessary;

(c) Technical information, special tools, equipment, lifting trunnions, spare parts and consumables needed to use and perform incidental maintenance on the cask(s); and

(d) Sufficient documentation on the equipment supplied by DOE.
[10 CFR 961.11 Article IV, B]

C. Interface: None specified at this time

Table F1.2.3.5.2 Function Description: Support MRS/Repository

I. Function ID Number: 1.2.3.5.2

II. Function Title: Support MRS/Repository

III. Function Definition:

Support MRS and repository activities by training and technical support.

IV. Interfaces:

A. Inputs: None identified at this time

B. Outputs: None identified at this time

V. Requirements:

A. Constraints: None specified at this time

B. Performance: None specified at this time

C. Interface: None specified at this time

Table F1.2.3.5.3 Function Description: Support In-Transit Operations

I. Function ID Number: 1.2.3.5.3

II. Function Title: Support In-Transit Operations

III. Function Definition:

Field operations support transportation operations with training and technical assistance for in-transit maintenance.

IV. Interfaces:

A. Inputs: None identified at this time

B. Outputs: None identified at this time

V. Requirements:

A. Constraints: None specified at this time

B. Performance: None specified at this time

C. Interface: None specified at this time

Table F1.2.3.5.4 Function Description: Support In-Transit Emergency Responses

I. Function ID Number: 1.2.3.5.4

II. Function Title: Support In-Transit Emergency Responses

III. Function Definition:

Support activities to recover a cask in event of an accident.

IV. Interfaces:

A. Inputs: None identified at this time

B. Outputs: None identified at this time

V. Requirements:

A. Constraints: None specified at this time

B. Performance: None specified at this time

C. Interface: None specified at this time

Table F1.2.3.6 Function Description: Move Unloaded Casks

- I. Function ID Number:** 1.2.3.6
- II. Function Title:** Move Unloaded Casks
- III. Function Definition:**

The movement of unloaded casks has been addressed as a separate support activity. The casks are referred to as unloaded rather than empty because an internally contaminated cask without fuel assemblies may not be considered empty according to Department of Transportation (DOT) definitions. These unloaded casks could come from the MRS, Repository and CMF, be newly purchased casks, or originate from other facilities where repair or maintenance operations have been carried out.

IV. Interfaces:

A. Inputs:

1.2.3.6I1	Unloaded SNF Casks/Transporters	From: Function 1.3 / 1.4 / 1.2.3.7
1.2.3.6I2	Unloaded CHLW Casks/Transporters	From: Function 1.4 / 1.2.3.7
1.2.3.6I3	Unloaded DHLW Casks/Transporters	From: Function 1.4 / 1.2.3.7
1.2.3.6I4	Prime Mover and Crew	From: Private Transportation Industry
1.2.3.6I5	Vehicles	From: Function 1.2.3.7.2

B. Outputs:

1.2.3.6O1	Unloaded SNF Casks/Transporters	To: Function 1.1 / 1.3 / 1.2.1.1
1.2.3.6O2	Unloaded CHLW Casks/Transporters	To: Function 1.1 / 1.2.1.1
1.2.3.6O3	Unloaded DHLW Casks/Transporters	To: Function 1.1 / 1.2.1.1
1.2.3.6O4	Shipping Documents	To: Function 1.1 / 1.3 / 1.2.1.1 / Purchaser, Producer
1.2.3.6O5	Vehicles	To: Function 1.2.3.7

V. Requirements:

A. Constraints:

1.2.3.6C1 (a) Each licensee who transports licensed material outside of the confines of its plant or other place of use, or who delivers licensed material to a carrier for transport, shall comply with the applicable requirements of the regulations appropriate to the mode of transport of DOT in 49 CFR Parts 170 through 189.

- (1) The licensee shall particularly note DOT regulations in the following areas:
 - (i) Packaging -- 49 CFR Part 173, Subparts A and B and 173.401 through 173.478.
 - (ii) Marking and labeling -- 49 CFR Part 172, Subpart D and 172.400 through 172.407; 172.436 through 172.440.
 - (iii) Placarding -- 49 CFR Part 172.500 through 172.519, 172.556 and Appendices B and C.
 - (iv) Monitoring -- 49 CFR Part 172, Subpart C.
 - (v) Accident reporting -- 49 CFR Part 171.15 and 171.16.
 - (vi) Shipping papers -- 49 CFR Part 172, Subpart C.
- (2) The licensee shall also note DOT regulations pertaining to the following modes of transportation:
 - (i) Rail -- 49 CFR Part 174, Subparts A - D and K.
 - (ii) Air -- 49 CFR Part 176, Subparts A - D and M.
 - (iii) Vessel -- 49 CFR Part 176, Subparts A - D and M.

(iv) Public Highway -- 49 CFR Part 177.

(b) If DOT regulations are not applicable to a shipment of licensed material by rail, highway, or water because the shipment or the transportation of the shipment is not in interstate or foreign commerce, or to a shipment of licensed material by air because the shipment is not transported in civil aircraft, the licensee shall conform to the standards and requirements of the DOT specified in paragraph (a) of this section to the same extent as if the shipment or transportation were in interstate or foreign commerce or in civil aircraft. A request for modification, waiver, or exemption from those requirements, and any notification referred to in those requirements, must be filed with or made to the Director, Office of Nuclear Material Safety and Safeguards, U.S. Nuclear Regulatory Commission, Washington, DC 20555.

[10 CFR 71.5]

1.2.3.6C2 Routing and training requirements for Class 7 (radioactive) materials.

(a) Except as provided in paragraph (b) of this section, a carrier or any person operating a motor vehicle that contains a Class 7 (radioactive) material for which placarding is required under part 172 of this subchapter shall--

- (1) Ensure that the motor vehicle is operated on routes that minimize radiological risk;
- (2) In determining the level of radiological risk, consider available information on accident rates, transit time, population density and activities, and the time of day and the day of week during which transportation will occur; and
- (3) Tell the driver which route to take and that the motor vehicle contains Class 7 (radioactive) materials.

The requirements of this paragraph do not apply when there is only one practicable highway route available, considering operating necessity and safety, or when the routing of the motor vehicle is subject to paragraph (b) of this section.

[49 CFR 177.825]

B. Performance: None specified at this time

C. Interface: None specified at this time

Table F1.2.3.6.1 Function Description: Transport Unloaded Casks

- I. Function ID Number:** 1.2.3.6.1
- II. Function Title:** Transport Unloaded Casks
- III. Function Definition:**

This function is responsible for the movement of the unloaded cask system. It includes the integration of both escort and inspection activities.

IV. Interfaces:

A. Inputs:

1.2.3.6.1I1	Unloaded SNF Casks/Transporters/ Documents	From: Function 1.3 / 1.4 / 1.2.3.7
1.2.3.6.1I2	Unloaded CHLW Casks/Transporters/ Documents	From: Function 1.4 / 1.2.3.7
1.2.3.6.1I3	Unloaded DHLW Casks/Transporters/ Documents	From: Function 1.4 / 1.2.3.7
1.2.3.6.1I4	Prime Mover and Crew	From: Private Transportation Industry

B. Outputs:

1.2.3.6.1O1	Unloaded SNF Cask Shipment	To: Function 1.2.3.6.3 / 1.2.3.6.4 / 1.2.3.6.5
1.2.3.6.1O2	Unloaded CHLW Cask Shipment	To: Function 1.2.3.6.3 / 1.2.3.6.4 / 1.2.3.6.5
1.2.3.6.1O3	Unloaded DHLW Cask Shipment	To: Function 1.2.3.6.3 / 1.2.3.6.4 / 1.2.3.6.5
1.2.3.6.1O4	Shipment Status Information	To: Function 1.2.3.6.6

V. Requirements:

A. Constraints:

1.2.3.6.1C1 Responsibility for compliance.

Unless this subchapter specifically provides that another person is to perform a particular duty, each carrier, including a connecting carrier, shall perform the duties specified and comply with each applicable requirement of this part, and shall instruct its employees in relation thereto. [49 CFR 174.7]

1.2.3.6.1C2 Responsibility for compliance.

Unless this subchapter specifically provides that another person must perform a duty, each carrier, including a connecting carrier, shall comply with all applicable regulations in this part, and shall thoroughly instruct his employees in relation thereto. [49 CFR 176.13]

1.2.3.6.1C3 Subpart A -- General Information and Regulations

Compliance with Federal Motor Carrier Safety Regulations.

Motor carriers and other persons subject to this part shall comply with 49 CFR Parts 390 through 397 (excluding Sections 397.3 and 397.9) to the extent those rules apply. [49 CFR 177.804]

B. Performance: None specified at this time

C. Interface: None specified at this time

Table F1.2.3.6.2 Function Description: Acquire In-Transit Permits

- I. Function ID Number:** 1.2.3.6.2
- II. Function Title:** Acquire In-Transit Permits
- III. Function Definition:**

For routine shipments, permits are obtained in advance of the shipments. The need for permits is determined, applied for, and provided in advance by the Dispatch function of Traffic Planning.

Carriers may apply for permits on a case-by-case basis, but Dispatch shall be advised when the permits are obtained.

IV. Interfaces:

A. Inputs:

1.2.3.6.2I1 Permits **From:** States, Tribes, DOT, NRC

B. Outputs:

1.2.3.6.2O1 Permits **To:** Function 1.2.3.6.1 (Control)

V. Requirements:

- A. Constraints:** None specified at this time
 - B. Performance:** None specified at this time
 - C. Interface:** None specified at this time
-
-

Table F1.2.3.6.3 Function Description: Perform In-Transit Repairs

- I. Function ID Number:** 1.2.3.6.3
- II. Function Title:** Perform In-Transit Repairs
- III. Function Definition:**

The train crew is responsible for verifying the need for in-transit repair and, after confirming the need with the Dispatch function, for initiating the maintenance action. All repairs are expected to take place at typical repair facilities and may require the implementation of additional physical security actions to ensure protection of the unloaded cask. Coordination of the maintenance action takes place through the Dispatch function.

IV. Interfaces:

A. Inputs:

1.2.3.6.3I1 [Unloaded SNF Cask Shipment] **From:** Function 1.2.3.6.1
1.2.3.6.3I2 [Unloaded CHLW Cask Shipment] **From:** Function 1.2.3.6.1
1.2.3.6.3I3 [Unloaded DHLW Cask Shipment] **From:** Function 1.2.3.6.1

B. Outputs:

1.2.3.6.3O1	[Unloaded SNF Cask Shipment]	To:	Function 1.2.3.6.4 / 1.2.3.6.5
1.2.3.6.3O2	[Unloaded CHLW Cask Shipment]	To:	Function 1.2.3.6.4 / 1.2.3.6.5
1.2.3.6.3O3	[Unloaded DHLW Cask Shipment]	To:	Function 1.2.3.6.4 / 1.2.3.6.5

V. Requirements:

A. Constraints: None specified at this time

B. Performance: None specified at this time

C. Interface: None specified at this time

Table F1.2.3.6.4 Function Description: Perform Intermodal Transfers

I. Function ID Number: 1.2.3.6.4

II. Function Title: Perform Intermodal Transfers

III. Function Definition:

Transportation operations function coordinates and carries out necessary intermodal transfers. The principal intermodal transfers are expected to take place between a heavy haul truck to train or train to truck, but other intermodal transfers will be made as required. Transfers involving a heavy haul trailer will require special transport equipment, as well as lifting fixtures and cranes. The cask is positioned on a skid, which is fitted with fixtures for lifting so that no direct handling of the cask is required.

IV. Interfaces:**A. Inputs:**

1.2.3.6.4I1	[Unloaded SNF Cask Shipment]	From:	Function 1.2.3.6.1 / 1.2.3.6.3
1.2.3.6.4I2	[Unloaded CHLW Cask Shipment]	From:	Function 1.2.3.6.1 / 1.2.3.6.3
1.2.3.6.4I3	[Unloaded DHLW Cask Shipment]	From:	Function 1.2.3.6.1 / 1.2.3.6.3

B. Outputs:

1.2.3.6.4O1	[Unloaded SNF Cask Shipment]	To:	Function 1.2.3.6.5
1.2.3.6.4O2	[Unloaded CHLW Cask Shipment]	To:	Function 1.2.3.6.5
1.2.3.6.4O3	[Unloaded DHLW Cask Shipment]	To:	Function 1.2.3.6.5

V. Requirements:**A. Constraints:****1.2.3.6.4C1 COMPLIANCE WITH TRANSPORTATION LAWS OR REGULATIONS**

c. Size and Weight Limitations for Highway shipments. Motor carrier shipments shall conform to State and local laws, regulations, and ordinances relating to weight and size limitations. No vehicular movement which exceeds any State's legal weight or size limitation shall be undertaken over public highways unless prior permission is formally granted by the state concerned. The

Department or Department's contractor support of a carrier requesting such permission may be furnished only after a determination that it is not practical to divide the load into smaller lots or feasible to move the material by other means of transportation.

[DOE Order 1540.1, CH-1,4]

B. Performance: None specified at this time

C. Interface: None specified at this time

Table F1.2.3.6.5 Function Description: Deliver Unloaded Casks

I. Function ID Number: 1.2.3.6.5

II. Function Title: Deliver Unloaded Casks

III. Function Definition:

This function consists of the delivery of an unloaded cask to the proper Purchaser (or the waste producer) site. Prior to delivery, the "Plan Campaigns and Transportation System Operations" function will determine that the cask, transporter, and ancillary equipment are suitable for use in the Purchaser's facility. This determination will be supported by the Final Delivery Schedule (FDS), pre-delivery survey documents, the Service Planning Documents, and the Site Specific Servicing Plans.

IV. Interfaces:

A. Inputs:

1.2.3.6.5I1	Unloaded SNF Cask Shipment	From: Function 1.2.3.6.1 / 1.2.3.6.3 / 1.2.3.6.4
1.2.3.6.5I2	Unloaded CHLW Cask Shipment	From: Function 1.2.3.6.1 / 1.2.3.6.3 / 1.2.3.6.4
1.2.3.6.5I3	Unloaded DHLW Cask Shipment	From: Function 1.2.3.6.1 / 1.2.3.6.3 / 1.2.3.6.4

B. Outputs:

1.2.3.6.5O1	Unloaded SNF Casks/Transporters	To: Function 1.1 / 1.2.1.1 / 1.3 / Purchaser
1.2.3.6.5O2	Unloaded CHLW Casks/Transporters	To: Function 1.1 / 1.2.1.1 / Producer
1.2.3.6.5O3	Unloaded DHLW Casks/Transporter	To: Function 1.1 / 1.2.1.1 / Producer
1.2.3.6.5O4	Shipping Documents	To: Function 1.1 / 1.2.1.1 / 1.3 / Purchaser, Producer
1.2.3.6.5O5	Prime Mover and Crew	To: Private Transportation Industry
1.2.3.6.5O6	Arrival Notification	To: Function 1.2.3.6.6

V. Requirements:

A. Constraints:

1.2.3.6.5C1 Contamination of vehicles.

(a) Each motor vehicle used for transporting Class 7 (radioactive) materials under exclusive use conditions in accordance with Sec. 173.425(c) or Sec. 173.443(c) shall be surveyed with radiation detection instruments after each use. A vehicle may not be returned to service until the radiation dose rate at each accessible surface is 0.5 millirem per hour or less and the removable (non-fixed) radioactive surface contamination is not greater than the level prescribed in Sec. 173.443(a).

[49 CFR 177.843]

1.2.3.6.5C2 DOE shall arrange for, and provide, a cask(s) and all necessary transportation of the SNF and/or HLW from the Purchaser's site to the DOE facility. Such cask(s) shall be furnished sufficiently in advance to accommodate scheduled deliveries. Such cask(s) shall be suitable for use at the Purchaser's site, meet applicable regulatory requirements, and be accompanied by pertinent information including, but not limited to, the following:

- (a) written procedures for cask handling and loading, including specifications on Purchaser-furnished canisters for containment of failed fuel;
- (b) Training for Purchaser's personnel in cask handling and loading, as may be necessary;
- (c) Technical information, special tools, equipment, lifting trunnions, spare parts and consumables needed to use and perform incidental maintenance on the cask(s); and
- (d) Sufficient documentation on the equipment supplied by DOE. [10 CFR 961.11, IV.B.2]

B. Performance: None specified at this time

C. Interface:

1.2.3.6.5I1 Same as 1.2.3.6.5C1 above.

1.2.3.6.5I2 Same as 1.2.3.6.5C1 above.

1.2.3.6.5I3 Same as 1.2.3.6.5C1 above.

1.2.3.6.5O1 None specified at this time

1.2.3.6.5O2 None specified at this time

1.2.3.6.5O3 None specified at this time

1.2.3.6.5O4 None specified at this time

1.2.3.6.5O5 None specified at this time

Table F1.2.3.6.5.1 Function Description: Debrief Transportation Crew

I. Function ID Number: 1.2.3.6.5.1

II. Function Title: Debrief Transportation Crew

III. Function Definition:

The transportation crew must be debriefed by the "Manage Traffic" function and the Field Operations function upon arrival at the purchaser/producer or DOE site with respect to road or rail conditions, equipment problems related to repair or modification of the transporter or the prime mover, cask/transporter interface concerns, and security concerns.

IV. Interfaces:

A. Inputs: None identified at this time

B. Outputs: None identified at this time

V. Requirements:

A. Constraints: None specified at this time

B. Performance: None specified at this time

C. Interface: None specified at this time

Table F1.2.3.6.5.2 Function Description: Position Unloaded Cask/Transporter

I. Function ID Number: 1.2.3.6.5.2

II. Function Title: Position Unloaded Cask/Transporter

III. Function Definition:

The Carrier shall perform initial transporter spotting at a location designated by the purchasers, producer, or DOE, disconnect the tractor or locomotive, set brakes, and chock wheels. Subsequent repositioning is the responsibility of the receiver.

IV. Interfaces:

A. Inputs: None identified at this time

B. Outputs: None identified at this time

V. Requirements:

A. Constraints:

1.2.3.6.5.2C1 Procedures for receiving and opening packages.

(b) Each licensee shall monitor the external surfaces of a package known to contain radioactive material for radioactive contamination and radiation levels if the package--

(1) Is labeled as containing radioactive material; or

(2) Has evidence of potential contamination, such as packages that are crushed, wet, or damaged.

(c) The licensee shall perform the monitoring required by paragraph (b) of this section as soon as practicable after receipt of the package, but not later than 3 hours after the package is received at the licensee's facility if it is received during the licensee's normal working hours, or not later than 3 hours from the beginning of the next working day if it is received after working hours.
[10 CFR 20.1906]

B. Performance: None specified at this time

C. Interface: None specified at this time

Table F1.2.3.6.5.3 Function Description: Transfer Shipping Documents

- I. Function ID Number:** 1.2.3.6.5.3
- II. Function Title:** Transfer Shipping Documents
- III. Function Definition:**

The entire shipping documents package shall be delivered to the producer, purchaser or DOE, along with any supplemental documentation provided by the shipper. Receipt of shipment is confirmed by signature of the producer/purchaser representative on the freight bill, with a copy of the bill retained by the carrier. Designation of the producer/purchaser representative will be determined by an approved Site-Specific Service procedure.

IV. Interfaces:

A. Inputs:

1.2.3.6.5.3I1 Shipping Documents **From:** Function 1.2.3.6.5.1

B. Outputs:

1.2.3.6.5.3O1 Shipping Documents **To:** Function 1.1 / 1.3 / 1.2.1.1 / Purchaser, Producer

V. Requirements:

- A. Constraints:** None specified at this time
 - B. Performance:** None specified at this time
 - C. Interface:** None specified at this time
-
-

Table F1.2.3.6.6 Function Description: Manage Traffic

- I. Function ID Number:** 1.2.3.6.6
- II. Function Title:** Manage Traffic
- III. Function Definition:**

The Manage Traffic function provides the communications, control, and oversight for, and the transport of unloaded casks. Incorporated within this function are dispatch operations that involve scheduling and coordination of traffic flow, issuing of dispatch orders, notification of appropriate authorities, monitoring of all transportation activities and communications, and support activities that include providing assistance for obtaining special transport permits enroute and emergency response and communications for incidents which might occur during the transport operations. Traffic management is a level of effort activity which commences when the shipping activities begin and runs throughout the life of the transportation system.

IV. Interfaces:**A. Inputs:**

1.2.3.6.6I1	Arrival Notification	From: Function 1.2.3.6.5
1.2.3.6.6I2	Shipment Status Information	From: Function 1.2.3.6.1

B. Outputs:

1.2.3.6.6O1	(Revised) Operation Orders	To: Function 1.2.3.6.1 (Control) / 1.2.3.6.3 (Control) / 1.2.3.6.4 (Control) / 1.2.3.6.5 (Control)
-------------	----------------------------	---

V. Requirements:**A. Constraints:****1.2.3.6.6C1** Completeness and accuracy of information.

(a) Information provided to the Commission by an applicant for a license or by a licensee or information required by statute or by the Commission's regulations, orders, or license conditions to be maintained by the applicant or the licensee shall be complete and accurate in all material respects.

[10 CFR 71.6a]

B. Performance: None specified at this time**C. Interface:** None specified at this time

Table F1.2.3.6.6.1 Function Description: Prepare/Coordinate Traffic Flow Schedules

I. Function ID Number: 1.2.3.6.6.1**II. Function Title:** Prepare/Coordinate Traffic Flow Schedules**III. Function Definition:**

In support of the campaign planning, transportation schedules developed will identify and provide for the equipment, services, and support to meet the objectives and milestones within the campaign plans. This will include integration of physical movements of equipment and unloaded casks such that competing demands for services, equipment, facilities, and support are resolved, and that special conditions and restrictions are properly fulfilled. Traffic management personnel will coordinate all schedules with the purchaser or shipping activity, the field operations teams and security escorts, the applicable receiving activity, the supporting transportation service organization(s) [railroads, trucking companies, barging companies, riggers, etc], and applicable state and local officials. While most schedules may be campaign specific, the coordination of these schedules is a level of effort activity which commences when shipping activities begin and runs throughout the life of the transportation system.

IV. Interfaces:**A. Inputs:** None identified at this time**B. Outputs:** None identified at this time**V. Requirements:****A. Constraints:** None specified at this time

B. Performance: None specified at this time

C. Interface: None specified at this time

Table F1.2.3.6.6.2 Function Description: Monitor Traffic Flow Status

I. Function ID Number: 1.2.3.6.6.2

II. Function Title: Monitor Traffic Flow Status

III. Function Definition:

Transport communications, activities, and schedules are continuously monitored to identify potential problems and conflicts, and to make or recommend changes to schedules, routes, and other transportation activities to resolve actual and potential problems. Additionally, official records and logs are maintained to collect and record information on performance related to schedules, document schedule changes, and provide information that can be used to improve transportation management and scheduling operations. Monitoring of traffic flow is a level of effort activity and commences once shipping activities begin and continues throughout the life of the Transportation System.

IV. Interfaces:

A. Inputs: None identified at this time

B. Outputs: None identified at this time

V. Requirements:

A. Constraints: None specified at this time

B. Performance: None specified at this time

C. Interface: None specified at this time

Table F1.2.3.6.6.3 Function Description: Issue Dispatch Orders

I. Function ID Number: 1.2.3.6.6.3

II. Function Title: Issue Dispatch Orders

III. Function Definition:

Dispatch orders are the execution mechanism by which transportation support and services are provided. Dispatch orders may consist of an order to a carrier to provide equipment or services at a specific place and time, or to an operator to move a cask from one place to another. The dispatch order provides specific instructions to a carrier that include routing and alternate routing instructions. Issuance of dispatch orders is keyed to schedules and accomplishment of specific activities, such as completion of all preparations for shipment of a cask. Initial preparation of the dispatch order commences with receipt of a coordinated schedule and terminates with delivery of the dispatch order to the carrier. Coordination of in-transit repairs takes place through this function.

IV. Interfaces:

A. Inputs: None identified at this time

B. Outputs: None identified at this time

V. Requirements:

A. Constraints: None specified at this time

B. Performance: None specified at this time

C. Interface: None specified at this time

Table F1.2.3.6.6.4 Function Description: Obtain Special Transport Permits

I. Function ID Number: 1.2.3.6.6.4

II. Function Title: Obtain Special Transport Permits

III. Function Definition:

All special transport permits required by Federal, state, and local laws and regulations are obtained prior to commencement of each shipment. A specific example would be all state and local permits for unloaded cask movements, where oversize or overweight conditions exist along the route. Operations personnel in the OCC may be called upon to obtain these special permits required by state and local law and regulations. This activity commences with completion of a coordinated campaign plan and terminates with delivery of the permits to the carrier's operators, or it commences with notification of OCC personnel that an event has occurred which has generated the requirement for a special permit and terminates when the operator of the equipment requiring the permit receives the permit.

IV. Interfaces:

A. Inputs: None identified at this time

B. Outputs: None identified at this time

V. Requirements:

A. Constraints:

1.2.3.6.6.4C1 COMPLIANCE WITH TRANSPORTATION LAWS OR REGULATIONS

c. Size and Weight Limitations for Highway shipments. Motor carrier shipments shall conform to State and local laws, regulations, and ordinances relating to weight and size limitations. No vehicular movement which exceeds any State's legal weight or size limitation shall be undertaken over public highways unless prior permission is formally granted by the state concerned. The Department or Department's contractor support of a carrier requesting such permission may be furnished only after a determination that it is not practical to divide the load into smaller lots or feasible to move the material by other means of transportation.

[DOE Order 1540.1, Ch-I, 4]

B. Performance: None specified at this time

C. Interface: None specified at this time

Table F1.2.3.6.6.5 Function Description: Support Emergency Response Communications

I. Function ID Number: 1.2.3.6.6.5

II. Function Title: Support Emergency Response Communications

III. Function Definition:

There is a definite need to communicate during an emergency which could occur in the course of OCRWM Transportation Systems operations. Since it is not possible to predict any emergency, it is necessary, if not essential, to provide an on-hand or standby capability that will permit the OCC to communicate with the on-scene personnel, MRS, MGDS, and Federal, State, and local officials. The OCC will additionally be providing emergency response support, as requested by DOE, through mobilization and dispatching of emergency response teams and equipment. To direct these efforts and assure that appropriate timely response is provided, the OCC will need to communicate with and monitor the progress and activity of support efforts. The emergency response communications capability will be required from the commencement of transportation operations and will run throughout the life of the program, but would only be employed from notification of an emergency until the appropriate authorities declare an end of the emergency.

IV. Interfaces:

A. Inputs: None identified at this time

B. Outputs: None identified at this time

V. Requirements:

A. Constraints:

1.2.3.6.6.5C1 All DOE-owned shipments of radioactive and other hazardous materials, substances, and wastes will comply with the DOE requirements for Emergency Response Information cited in 49 CFR, Subpart G, Sections 172.600 - 172.604.

[DOE Order 1540.1, Ch II, 7(c)(3)]

1.2.3.6.6.5C2 OCCURRENCE CATEGORIZATION, NOTIFICATION AND REPORTING REQUIREMENTS.

a. Categorization. Categorization of Reportable Occurrences shall be made as soon as practicable and, in all cases, within 2 hours of identification. If categorization is not clear, then the occurrence shall be initially categorized at the higher level being considered and DOE notified in accordance with this Order. The occurrence categorization shall either be elevated, maintained, or lowered as information is made available. The categories of Reporting Occurrences are:

(1) Emergencies. Emergencies are the most serious occurrences and require an increased alert status for onsite personnel and, in specified cases, for offsite authorities. The detailed definitions and classifications of emergencies and appropriate emergency responses to be taken are provided in DOE 5500.2B. The types of occurrences that are to be categorized as emergencies are:

(a) Any unintentional nuclear criticality that results or could result in actual or potential facility damage or release of radioactive material to the environment;

(b) Any actual or potential release of material to the environment which results or could result in significant offsite consequences;

(c) Any natural or man-made event posing an actual or potential threat to the integrity of the facility, that results or could result in significant offsite consequences;

(d) Any event in process or having occurred which involves an actual or potential substantial degradation of the level of safety of the facility that results or could result in significant offsite consequences; or

(e) Any safeguards or security event which is an actual or potential threat to DOE operations, facilities, or personnel, and results or could result in significant effects on the public health and safety and/or on national security.

(f) Any event which requires activation of the site emergency plan.

(2) Unusual Occurrences. An unusual occurrence is a non-emergency occurrence that has significant impact or potential for impact on safety, environment, health, security, or operations. The types of occurrences that are to be categorized as unusual occurrences are those that:

(a) Result in the release of radioactive or hazardous materials above limits established in, or violate safety, environment, or health requirements defined in, permits or regulations;

(b) Are significant internal or external threats to safety, environment, or health protection or the ability of a facility to operate;

(c) Involve significant degradation of safety systems or environmental, safety, or health conditions;

(d) Result in fatalities, exposures to hazardous or radioactive materials or offsite or onsite contamination in excess of regulatory allowable limits, but less than protective response recommendations as defined in DOE 5500.3A, failure of environmental monitoring equipment necessary to demonstrate compliance, failure of safety equipment or systems reducing the capability below a minimum required safety function, or significant delay or cost in operations;

(e) Result in the actuation of emergency systems or engineered safety features, except under approved testing;

(f) Violate technical specifications, operational safety requirements, or involve an unreviewed safety question;

(g) Violate DOE safety requirements, environmental requirements, or result in the loss of control or release of radioactive material above allowable limits; or

(h) Result in the release of a hazardous substance or material that exceeds a reportable quantity and is not federally permitted as defined in Attachment I.

(3) Off-Normal Occurrences. Off-normal occurrences are abnormal or unplanned events or conditions that adversely affect, potentially affect, or are indicative of degradation in, the safety, security, environmental or health protection performance or operation of a facility. The types of occurrences that are to be categorized as off-normal occurrences are those that:

(a) Are internal or external threats to safety, environmental, or health protection or the ability of a facility to operate;

(b) Involve degradation of environmental, safety or health conditions;

(c) Result in serious personnel injury or significant lost workdays; personnel contamination, assimilation, exposure, or significant onsite or offsite contamination of hazardous or radioactive materials in excess of administrative limits but within regulatory limits; or degradation of environmental monitoring equipment necessary to demonstrate compliance;

(d) Result in the violation of safety, environmental, or health administrative limits; or

(e) Involve operational procedural violations, including maintenance and administrative procedures which have the potential to impact the safety, security, environmental or health performance or operation of a facility.

b. Notification. Requirements for oral and documented notification of Reportable Occurrences are as follows:

- (1) Emergencies. Oral notification to DOE and offsite authorities of emergencies shall be made within 15 minutes or less of categorization. A Notification Report shall be prepared and submitted as soon as practical but, in all cases, within 24 hours of categorization.
- (2) Unusual Occurrences. Oral notification to DOE on unusual occurrences shall be as soon as sufficient information is obtained to indicate the general nature and extent of the occurrence but, in all cases, within 2 hours of categorization. A Notification Report shall be prepared and submitted within 24 hours of categorization.
- (3) Off-Normal Occurrences. For off-normal occurrences, oral notification to DOE is not mandatory; however, a Notification Report shall be prepared and submitted within 24 hours of categorization.

[DOE Order 5000.3A, 7]

1.2.3.6.6.5C3 IMPLEMENTATION REQUIREMENTS.

a. Occurrence Categorization and Notification Process.

- (1) The facility staff and operators shall identify and promptly notify the Facility Manager of abnormal events and conditions and record and archive all information pertaining to such occurrences.
- (2) Appropriate immediate response(s) shall be taken by contractor operations personnel to stabilize or return the facility/operation to a safe condition.
- (3) The Facility Manager shall categorize the occurrence as required in Paragraph 7a of this Order utilizing the facility specific procedures developed in accordance with Paragraph 8d(2) of this Order.
- (4) The Facility Manager or his or her designee shall be available at all times to carry out the requirements of this Order.
- (5) For oral notification, the Facility Manager shall simultaneously contact the DOE Facility Representative and the HQ EOC through which the DOE Program Manager or his or her designee and any other necessary program staff can be located and direct communications links with the Facility Manager established. The HQ EOC function here is to facilitate communications within line organizations, and to record and archive conversations. The Facility Manager may use the local Field/Site EOC to expedite establishing the direct communication link required above.
- (6) The Program Manager or his or her designee shall notify his or her PSO of the occurrence, and, for emergencies, the PSO shall notify the Secretary, the Office of Environment Safety and Health, and, as appropriate, the Office of Nuclear Safety. For all other occurrences; the PSO shall use judgment as to notification of these Departmental elements.
- (7) The DOE Facility Representative or his or her designee shall be available at all times to carry out the requirements of this Order.
- (8) The DOE Facility Representative shall notify the appropriate Head of the Field Organization of Reportable Occurrences.
- (9) During the entire process of notification and reporting, as noted in this Order, the DOE Facility Representative and Program Manager should use the current management chain established for the line organization in providing program direction to the contractor.
- (10) The Facility Manager shall prepare and submit the Notification Report (fields 1 through 18 of the Occurrence Report), and distribute it to the DOE Facility

Representative and Program Manager within 24 hours of categorization of the occurrence. If the Facility Manager submits the Notification Report by using the computerized DOE Operational Data Base, Paragraph 8c(1) below, then the distribution requirement is automatically satisfied.

[DOE Order 5000.3A, 8]

B. Performance: None specified at this time

C. Interface: None specified at this time

Table F1.2.3.6.6.6 Function Description: Collect/File Transportation Records

I. Function ID Number: 1.2.3.6.6.6

II. Function Title: Collect/File Transportation Records

III. Function Definition:

All log books, documents, and records prepared during the life of the Transportation System operations must be collected and retained to fulfill legal and fiscal requirements. Records and documents will be generated that are campaign specific, while OCC operations will generate records that cover the overall program as well as multiple campaigns. Records collection, filing, and management for Transportation System operations and equipment is a level of effort activity that will run throughout the life of the Transportation System.

IV. Interfaces:

A. Inputs: None identified at this time

B. Outputs: None identified at this time

V. Requirements:

A. Constraints: None specified at this time

B. Performance: None specified at this time

C. Interface: None specified at this time

Table F1.2.3.7 Function Description: Manage Inventories

I. Function ID Number: 1.2.3.7

II. Function Title: Manage Inventories

III. Function Definition:

Manage the inventory of spare parts and consumable supplies to: (1) provide assurance that the necessary items are available in a suitable condition to support planned operations, and (2) provide accountability for program and DOE property.

IV. Interfaces:**A. Inputs:**

1.2.3.7I1	Schedules, Plans	From:	Function 1.2.3.1
1.2.3.7I2	Vehicles	From:	Function 1.2.3.6

B. Outputs:

1.2.3.7O1	Unloaded Casks, Equipment	To:	Function 1.2.3.6
1.2.3.7O2	Vehicles	To:	Function 1.2.3.6
1.2.3.7O3	Spare Parts and Consumables	To:	Function 1.2.3.4

V. Requirements:**A. Constraints:** None specified at this time**B. Performance:** None specified at this time**C. Interface:** None specified at this time

Table F1.2.3.7.1 Function Description: Manage Unloaded Cask

I. Function ID Number: 1.2.3.7.1**II. Function Title:** Manage Unloaded Cask**III. Function Definition:**

Provided for temporary storage and maintenance of records for inventory and accountability purposes. Unloaded casks are received, inspected, placed in storage, removed from storage, reinspected and released to the Support Waste Transportation Operation Function.

IV. Interfaces:**A. Inputs:**

1.2.3.7.1I1	Unloaded Casks	From:	Function 1.2.3.3.2.5
-------------	----------------	--------------	----------------------

B. Outputs:

1.2.3.7.1O1	Unloaded Casks	To:	Function 1.2.3.6
-------------	----------------	------------	------------------

V. Requirements:**A. Constraints:** None specified at this time**B. Performance:** None specified at this time**C. Interface:** None specified at this time

Table F1.2.3.7.2 Function Description: Manage Vehicles

I. Function ID Number: 1.2.3.7.2

II. Function Title: Manage Vehicles

III. Function Definition:

Provide for temporary storage and maintenance of records for inventory and accountability purposes. Vehicles are received, inspected, placed in storage, removed from storage, reinspected and released to the Support Waste Transportation Operation Function.

IV. Interfaces:

A. Inputs:

1.2.3.7.2I1 Vehicles **From:** Function 1.2.3.6

B. Outputs:

1.2.3.7.2O1 Vehicles **To:** Function 1.2.2.1.1 / 1.2.3.6

V. Requirements:

A. Constraints: None specified at this time

B. Performance: None specified at this time

C. Interface: None specified at this time

Table F1.2.3.7.3 Function Description: Manage Ancillary Equipment

I. Function ID Number: 1.2.3.7.3

II. Function Title: Manage Ancillary Equipment

III. Function Definition:

Ancillary equipment includes but is not limited to lifting devices, special tools, test equipment, vacuum drying equipment, adapters, etc. Provide for temporary storage and maintenance of records for inventory and accountability purposes. Ancillary equipment are received, inspected, placed in storage, removed from storage, reinspected and released to the Support Waste Transportation Operation Function.

IV. Interfaces:

A. Inputs:

1.2.3.7.3I1 Ancillary Equipment **From:** Function 1.2.3.3.2.5

B. Outputs:

1.2.3.7.3O1 Ancillary Equipment **To:** Function 1.1 / 1.2.1.1 / Purchaser, Producer

V. Requirements:

A. Constraints: None specified at this time

B. Performance: None specified at this time

C. Interface: None specified at this time

Table F1.2.3.7.4 Function Description: Manage Spare Parts and Consumables

I. Function ID Number: 1.2.3.7.4

II. Function Title: Manage Spare Parts and Consumables

III. Function Definition:

Manage spare parts and consumables by maintaining adequate supplies to meet demands of the maintenance function.

IV. Interfaces:

A. Inputs:

1.2.3.7.4I1 Spare Parts and Consumables **From:** Function 1.2.3.3.2.5

B. Outputs:

1.2.3.7.4O1 Spare Parts and Consumables **To:** Function 1.3. / 1.4 / 1.2.1.1 / 1.2.3.4 / Purchaser, Producer

V. Requirements:

A. Constraints: None specified at this time

B. Performance: None specified at this time

C. Interface: None specified at this time

3.0 ARCHITECTURE DESCRIPTION

Architecture is defined herein to be that part of the physical system actually built, found, or selected to perform a function subject to its stated requirements. Figure 5 portrays the architectural concepts that comprise a Waste Transportation System based on how DOE/OCRWM plans to satisfy its mission.

Tables A1 - A1.2.5.8 identify the specific requirements to be satisfied by each architectural concept, a rationale justifying the need for the architecture, and a description of the concept. A complete description of the Waste Transportation System and its components is not possible until more detailed design and development efforts are completed. Nevertheless, the concepts identified in Figure 5 should improve understanding of the overall concept.

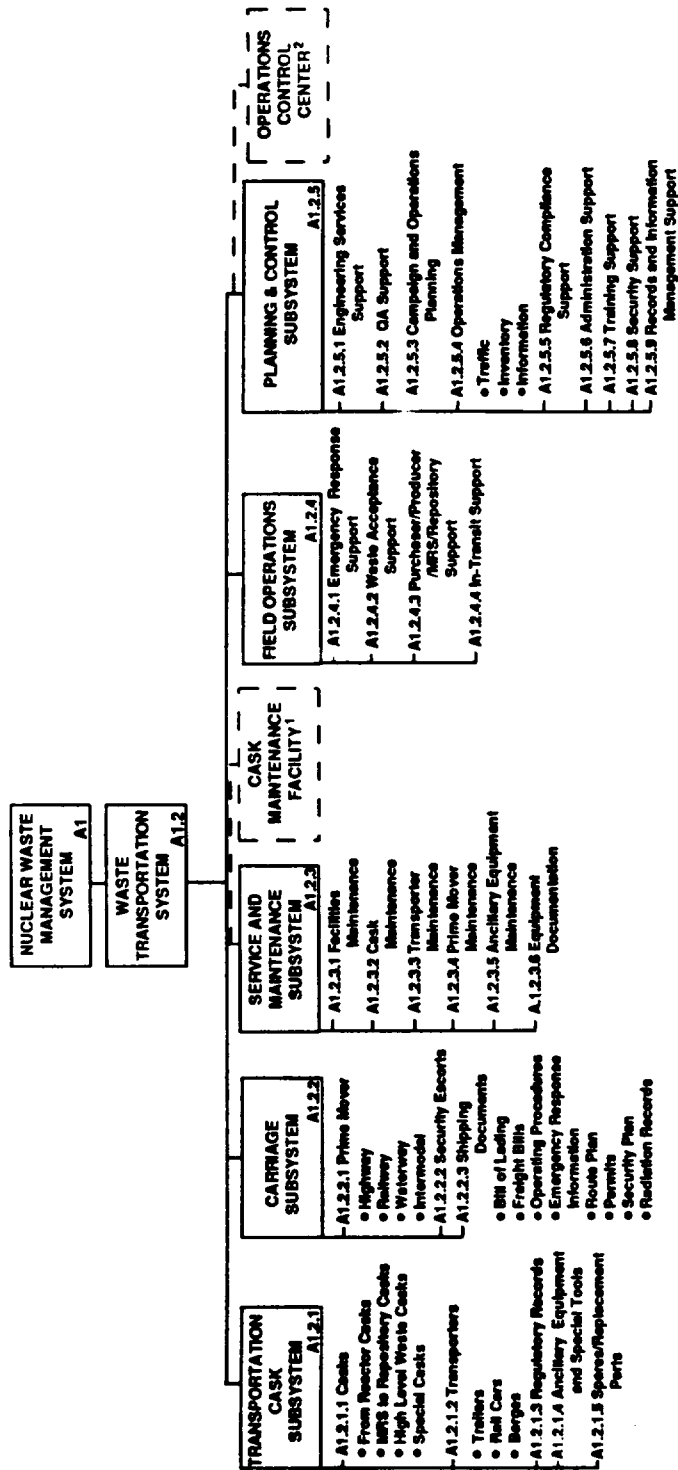

1. The CMF is collected with the MRS
2. The location of the OCC is yet to be decided

Figure 5. Transport Waste Architecture Tree

TWAT 00001

Table A.1 Nuclear Waste Management System

ARCHITECTURE: Nuclear Waste Management System

REQUIREMENTS SATISFIED:

1.C2, 1.C4 - 1.C7; 1.P1; 1.I1 - 1.I3; 1.O1, 1.O2

RATIONALE:

- ... to develop a technically sound integrated waste-management system
[DOE/RW-0247, Section 5]

DESCRIPTION:

- The Nuclear Waste Management System consists of the composite of the sites, and all facilities, systems, equipment, materials, information, activities, and the personnel required to perform those activities necessary to manage waste disposal.
-
-

Table A1.2 Waste Transportation System

ARCHITECTURE: Waste Transportation System

REQUIREMENTS SATISFIED:

1.2C5, 1.2C7 - 1.2C10, 1.2C12; 1.2P2; 1.2I1 - 1.2I3; 1.2O1 - 1.2O4; 1.2.1.1C1; 1.2.2C3, 1.2.2C4; 1.2.3.6C1; 1.2.3.6.5C2

RATIONALE:

- The Secretary, in providing for the transportation of spent nuclear fuel under this Act, shall utilize by contract private industry to the fullest extent possible in each aspect of such transportation
[NWPA Section 137 (a)(2)]

DESCRIPTION:

- The waste transportation system will consist of (1) the cask system, which includes transportation casks, vehicular conveyances, ancillary equipment, and associated handling equipment designed for use in the waste-management system; and (2) the transportation support system, which may include a control center, maintenance facilities, and the services and equipment required to support waste transportation.
-
-

Table A1.2.1 Transportation Cask Subsystem

ARCHITECTURE: Transportation Cask Subsystem

REQUIREMENTS SATISFIED:

1.2C11; 1.2I1b, 1.2.1I2b, 1.2.1I3b; 1.2.1O1 - 1.2.1O3; 1.2.2I1 - 1.2.2I3; 1.2.2.2.1C2, 1.2.2.2.1C6

RATIONALE:

- DOE shall arrange for, and provide, a cask(s) and all necessary transportation of the SNF and/or HLW from the Purchaser's site to the DOE facility [10 CFR 961 Article IV, B, 2]

DESCRIPTION:

- For shipping spent fuel from reactor sites to the MRS facility, we are developing new-generation casks, with capacities greater than those of existing casks, for shipment by truck and by rail or barge. We are also planning for the acquisition of existing casks as a complement to the casks being developed. We will also establish the capability for transportation operations. Besides the shipping casks and other equipment, this will require the procurement of the services of contractors who will arrange carriage, maintain equipment, inspect equipment, plan and schedule operations, and train personnel. [DOE/RW-0316P, Section 6]
-
-

Table A1.2.1.1 Casks

ARCHITECTURE: Casks

REQUIREMENTS SATISFIED:

1.2O5a - 1.2O5d, 1.2O6; 1.2.1I1a, 1.2.1I2a, 1.2.1I3a; 1.2.1.1C2 - 1.2.1.1C8; 1.2.1.1I1 - 1.2.1.1I3; 1.2.1.1O1 - 1.2.1.1O3; 1.2.1.4C1, 1.2.1.4C3; 1.2.1.4I1 - 1.2.1.4I3; 1.2.1.4O1b, 1.2.1.4O2b, 1.2.1.4O3b

RATIONALE:

- No spent nuclear fuel or high-level radioactive waste may be transported by or for the Secretary under subtitle A or under subtitle C except in packages that have been certified for such purpose by the Commission. [NWPA, Section 180 (a)]
 - ... Such cask(s) shall be suitable for use at the purchaser's site, meet applicable regulatory requirements, [10 CFR 961.11, Article IV, B, 2]
 - Transporting waste from reactor sites to receiving facilities will be accomplished using casks that are certified by the NRC for transport of appropriate materials and that can be physically handed at the interfacing facilities at the time of shipment. OCRWM is encouraging the development of new casks designs in order to enhance total system safety and efficiency and to ensure the availability of casks that are designed, built, and certified according to current regulations and proper interface requirements. These designs will be based on experience gained from the use of existing casks and could include concepts that are currently under development by private industry. [DOE/RW-0046, Section 4.1.1]
-

-
- The DOE will consider the use of existing casks (first certified prior to 1986) that already have valid certificates of compliance if the need arises at the time the DOE receives spent fuel under the Act. Existing casks may be used for spent fuel shipments as well as for special shipments where unique reactor facility or fuel characteristic requirements exist.
[DOE/RW-0046, Section 4.1.1]

DESCRIPTION:

- OCRWM plans to support development of new cask designs to meet the needs of the program. The cask will be designed by several suppliers in order to diversify sources. Also, creating a variety of designs will reduce the potential adverse impacts that may result from the removal of any single design from service. Casks for each primary mode of surface transportation will be developed in order to establish a complete matrix of acceptable options.
[DOE/RW-0046, Section 4.1.1]

- Casks are categorized into the following four (4) initiatives:

- Initiative 1 This initiative covers the development of casks that will be used to ship most (75-85%) of the spent nuclear fuel from utility reactors to the MRS. Initiative 1 is broken down into two phases. Phase 1 is the acquisition of a fleet of current technology from-reactor truck and rail casks that will support system startup commencing in January 1998. Phase 2 is the development of innovative technology from-reactor casks suitable for shipping standard fuel with increased capacities per cask shipment.

- Initiative 2 This initiative covers the development of transportation casks for the shipment of SNF from the MRS to the repository. These shipments will be made exclusively by rail and the cask will take advantage of increased capacity due to the heavier cask handling capabilities at the MRS and repository.

- Initiative 3 This initiative covers the development of transportation casks for the shipment of non-standard SNF and non-fuel bearing components or standard SNF that is not capable of being shipped in the initiative 1 casks.

- Initiative 4 This initiative covers the development of transportation casks for the shipment of high-level radioactive waste from its storage/generation site to the repository.

Table A1.2.1.2 Transporters

ARCHITECTURE: Transporters

REQUIREMENTS SATISFIED:

1.2.2.1.1C1 - 1.2.2.1.1C3

RATIONALE:

- DOE shall arrange for, and provide, ... all necessary transportation of the SNF and/or HLW from the Purchaser's site to the DOE facility.

[10 CFR 961.11, Article IV, B, 2]

DESCRIPTION:

- Transporters are the interface mechanism between the cask and the specific mode of transportation to be used for shipment. The transporter includes the highway trailer, heavy haul trailer, or rail car; the transport skid or intermodal skid; the tie-down components; personnel barrier; and miscellaneous equipment such as placard holders or decking. It may also include the tractor if a specific tractor is required to maintain the total gross vehicle weight (GVWt) within legal limits.
-
-

Table A1.2.1.3 Regulatory Records

ARCHITECTURE: Regulatory Records**REQUIREMENTS SATISFIED:**

1.2.1.4I5; 1.2.2.1.2C2

RATIONALE:

- Each licensee shall maintain sufficient written records to furnish evidence of the quality of the packaging. The records to be maintained include results of the determinations required by 71.85; design fabrication and assembly records; results of reviews, inspections, tests, and audits; results of maintenance, modification, and repair activities. Inspection, test and audit records must identify the inspector or data recorder, the type of observation, the results, the acceptability and action taken in connection with any deficiencies noted. The records must be retained for three years after the life of the packaging to which they apply. *[10 CFR 71.89 (c)]*

- The licensee shall make available to the Commission for inspection, upon reasonable notice, all records required by this part. Records are only valid if stamped, initialed, or signed and dated by authorized personnel or otherwise authenticated *[10 CFR 71.89 (b)]*

- Each record required by this part must be legible throughout the retention period specified by each commission regulation. The record must be the original or a reproduced copy or a microform provided that the copy or microform is authenticated by authorized personnel and that the microform is capable of producing a clear copy throughout the required retention period. The records may also be stored in electronic media with the capability for producing legible, accurate, and complete records during the required retention period. Records such as letters, drawings, specifications, must include all pertinent information such as stamps, initials, and signatures. The licensee shall maintain adequate safeguards against tampering with and loss of records. *[10 CFR 71.1 (b)]*

DESCRIPTION:

- A records management system must be established to provide for the maintenance, security, and accessibility of all required records.
 - The records will be maintained on a cask specific basis for the life of each cask in the cask fleet.
 - The records management system must comply with the requirements of the OCRWM QA Program for the maintenance and security of QA records.
-
-

Table A1.2.1.4 Ancillary Equipment and Special Tools

ARCHITECTURE: Ancillary Equipment and Special Tools

REQUIREMENTS SATISFIED:

1.2.2.1.1C1 - 1.2.2.1.1C3; 1.2.3.4P1

RATIONALE:

- ... Such cask(s) shall be suitable for use at the purchaser's site, meet applicable regulatory requirements, and be accompanied by pertinent information including but not limited to the following: ...

- (c) Technical information, special tools, equipment, lifting trunnions, spare parts, and consumables needed to use and perform incidental maintenance on the cask(s)
[10 CFR 961.11, Article IV, B, 2]

DESCRIPTION:

- Included in the transportation program is the development of equipment for handling the shipping casks. We have identified the 'cask handling equipment (e.g. yokes, special tools) that will be needed. Our general objective is to standardize wherever possible and to avoid designs requiring special tools.
[DOE/RW-0316P, Section 6]

- We are also interested in using remotely controlled and automated equipment for cask handling. One benefit of using such equipment is precision. More important, it decreases the exposure of workers to radiation, and we are therefore encouraging the cask contractors to design casks to accommodate automated equipment.
[DOE/RW-0316P, Section 6]

- Ancillary Equipment includes:

- Fixtures, equipment and tools for cask filling, draining, evacuation, drying, inerting, and sampling;
- Fixtures, equipment, and tools for leak testing; and
- Reusable shipping containers for ancillary equipment.

- Special Tools includes:

- Tools and lifting fixtures for impact limiter removal, storage, and installation; for tie-down removal or installation; and for removal or installation of the cask onto the transporter;
 - Tool fasteners, and lifting fixtures for closure lid removal, storage, and installation; for removal and installation of internal components; and for removal and installation of other cask components;
 - Tools required for seal installation and removal; and
 - Reusable shipping containers for special tools.
-
-

Table A1.2.1.5 Spares/Replacement Parts

ARCHITECTURE: Spares/Replacement Parts

REQUIREMENTS SATISFIED:

1.2.2.1.1C1 - 1.2.2.1.1C3; 1.2.3.4P1

RATIONALE:

- ... Such cask(s) shall be suitable for use at the purchaser's site, meet applicable regulatory requirements, and be accompanied by pertinent information including but not limited to the following: ...

(c) Technical information, special tools, equipment, lifting trunnions, spare parts, and consumables needed to use and perform incidental maintenance on the cask(s)
[10 CFR 961.11, Article IV, B, 2]

DESCRIPTION:

- In order to ensure the availability of casks and other parts of the Transportation Cask System, a supply of repair parts and other consumable items must be available.
 - Spare/replacement parts must be controlled, warehoused, and distributed as required, to ensure equipment usability and to comply with Quality Assurance requirements.
-
-

Table A1.2.2 Carriage Subsystem

ARCHITECTURE: Carriage Subsystem

REQUIREMENTS SATISFIED:

1.2.2C9 - 1.2.2C12; 1.2.2.1.3C1; 1.2.2.2.1C1, 1.2.2.2.1C2, 1.2.2.2.1C6; 1.2.2.4.7C2 - 1.2.2.4.7C4; 1.2.3.6C2

RATIONALE:

- The Secretary, in providing for the transportation of spent fuel under this Act, shall utilize by contract private industry to the fullest extent possible in each aspect of such transportation
[NFWPA, Section 137 (a)(2)]

- DOE shall arrange for, and provide, a cask(s) and all necessary transportation of the SNF and/or HLW from the Purchaser's site to the DOE facility
[10 CFR 961.11, Article IV, B, 2]

DESCRIPTION:

- If service contracts are awarded to private companies, these organizations would be required to conduct carriage arrangements subject to the DOE transportation policy that is in effect at the time shipment commences. The Office of Civilian Radioactive Waste Management will provide program supervision in all carrier discussions and negotiations.

Although details depend on the actual placement of contracts, the service contractors will be a focus of expertise in the transport of radioactive waste and will thus make appropriate shipping arrangements with common or contract carriers. Since DOE will be the official shipper of radioactive waste, all transportation operations will be conducted under rigorous DOE supervision.

[DOE/RW-0046, Section 5.1.2]

Table A1.2.2.1 Prime Mover

ARCHITECTURE: Prime Mover

REQUIREMENTS SATISFIED:

1.2.2C7, 1.2.2C8; 1.2.2.1C1; 1.2.2.1I4; 1.2.2.1.1C1 - 1.2.2.1.1C3; 1.2.2.1.3C2, 1.2.2.1.3C3; 1.2.2.2.1C3 - 1.2.2.2.1C5; 1.2.2.2.4C3; 1.2.2.3O5; 1.2.2.3.1C1; 1.2.3.6.1C1 - 1.2.3.6.1C3; 1.2.3.6.4C1; 1.2.3.6.5C1; 1.2.3.6.5I1 - 1.2.3.6.5I3; 1.2.3.6.5.2C1

RATIONALE:

- DOE shall arrange for, and provide, a cask(s) and all necessary transportation of the SNF and/or HLW from the Purchaser's site to the DOE facility
[10 CFR 961.11, Article IV, B, 2]

- In order to provide the necessary transportation of the cask systems from the owner's site, OCRWM will require the use of a prime mover to provide motive power for the transporter. Prime movers may be tractors, locomotives, heavy haul tractors and trailers, and/ or barges and tugs. These prime movers may be provided by private industry or they may be provided by OCRWM as part of the cask system. Regardless, all prime movers will be operated and maintained by a contractor who will provide transport services. In addition to the equipment, the contractors will also provide the required operating crews. All equipment and crew members will be in full compliance with regulatory requirement as outlined by DOT charged with regulation of that specific mode.

DESCRIPTION:

- For highway shipments. The transporter is equipped with NRC-approved features that permit immobilization of the cab or cargo-carrying portion of the vehicle.
[10 CFR 73.37(c)(4)]

- For highway shipments. The driver has in his immediate possession a certificate of training as evidence of training required by this section
[49 CFR 177.825 (d)(2)]

- Motor carriers and other persons subject to this part shall comply with Parts 390 through 397 (excluding 397.3 and 396.9) to the extent those rules apply.
[49 CFR 177.804]

- In providing prime movers, crew and other equipment rail carriers shall comply with Parts 200 through 268 to the extent those rules apply.

-
- In providing prime movers, crew and other equipment all carriers will comply with the applicable hazardous material requirements identified in either 49 CFR parts 174, 176, or 177 based on the mode of transport.
-
-

Table A1.2.2.2 Security Escorts

ARCHITECTURE: Security Escorts

REQUIREMENTS SATISFIED:

1.2.2C13, 1.2.2C14; 1.2.2.1.2C1; 1.2.2.2.4C1, 1.2.2.2.4C2, 1.2.2.2.4C4, 1.2.2.2.4C5

RATIONALE:

- ... For any shipment of irradiated reactor fuel, the shipper shall provide physical protection in compliance with a plan established under:

(1) Requirements prescribed by the U.S. Nuclear Regulatory Commission,
[49 CFR 173.22(c)]

- Each licensee who transports or delivers to a carrier for transport, in a single shipment, a quantity of irradiated reactor fuel in excess of 100 grams in net weight of irradiated fuel, exclusive of cladding or other structural or packaging material, which has a total external radiation dose rate in excess of 100 REMs per hour at a distance of 3 feet from any accessible surface without intervening shielding, shall establish and maintain, or make arrangements for, and assure the proper implementation of a physical protection system for the shipments of such material
[10 CFR 73.37 (a)(1)]

- Shipment by road. In addition to the provisions of paragraph (b), the physical protection system for any portion of a spent fuel shipment that is by road shall provide that:

(1) A transport vehicle within a heavily populated area is:

(i) Occupied by at least two individuals, one of whom serves as escort, and escorted by an armed member of the local law enforcement agency in a mobile unit of such agency, or

(ii) Led by a separate vehicle occupied by at least one armed escort, and trailed by a third vehicle occupied by at least one armed escort.

(2) A transport vehicle not within any heavily populated area is:

(i) Occupied by at least one driver and one other individual who serves as escort, or

(ii) Occupied by a driver and escorted by a separate vehicle occupied by at least two escorts; or

(iii) Escorted as set forth in paragraph (c)(1) of this section
[10 CFR 73.37(c)]

-
- Shipments by rail. In addition to the provisions of paragraph (b), the physical protection system for any portion of a spent fuel shipment that is by rail shall provide that:

(1) A shipment car within a heavily populated area is accompanied by two armed escorts (who may be members of local law enforcement agency), at least one of whom is stationed at a location on the train that will permit observation of the shipment car while in motion.

(2) A shipment car not within any heavily populated area is accompanied by at least one escort stationed at a location on the train that will permit observation of the shipment car while in motion.

[10 CFR 73.37 (d)]

DESCRIPTION:

- Provide for maintenance of a written log by the escorts and communications center personnel for each spent fuel shipment, which will include information describing the shipment and significant events that occur during the shipment,

[10 CFR 73.37 (b)(5)]

- Provide that at least one escort maintains visual surveillance of the shipment during periods when the shipment vehicle is stopped or the shipment vessel is docked.

[10 CFR 73.37 (b)(9)]

- Provide that escorts (other than members of local law enforcement agencies, or ship's officers serving as unarmed escorts) have successfully completed the training required by Appendix D of this part.

[10 CFR 73.37(b)(10)]

- Provide that the shipment escorts make calls to the communications center at least every 2 hours to advise of the status of the shipment for road and rail shipments, and for sea while shipment vessels are docked at U.S. ports.

[10 CFR 73.37(b)(11)]

- Escorts have the capability of communicating with the communications center, local law enforcement agencies, and one another, through the use of:

(i) A citizens band (CB) radio available in the transport vehicle and in each escort vehicle;

(ii) A radiotelephone or other NRC-approved equivalent means of two way voice communication available in the transport vehicle or in an escort vehicle committed to travel the entire route; and

(iii) Citizens band (CB) radio and normal local law enforcement agency radio communications in any local law enforcement agency mobile unit used for escort purposes.

[10 CFR 73.37(c)(3)]

- Escorts have the capability of communicating with the communications center, local law enforcement agencies, and one another, through the use of a radiotelephone or other NRC-approved equivalent means of two way voice communications, which shall be available on the train.

[10 CFR 73.37 (d)(3)]

Table A1.2.2.3 Shipping Documents

ARCHITECTURE: Shipping Documents

REQUIREMENTS SATISFIED:

1.2.1.1C7; 1.2.1.1O1b, 1.2.1.1O2b, 1.2.1.1O3b; 1.2.1.4C2; 1.2.1.4O1a, 1.2.1.4O2a, 1.2.1.4O3a;
1.2.2C5; 1.2.2.1C1; 1.2.2.114; 1.2.2.1.2C1; 1.2.2.1.2C3 - 1.2.2.1.2C21; 1.2.2.4.6C1;
1.2.2.4.7C1

RATIONALE:

- ... each person who offers a hazardous material for transport shall describe the hazardous material on the shipping paper in the manner required by this subpart. *[49 CFR 172.200 (a)]*

DESCRIPTION:

- Shipping paper means a shipping order, bill of lading, manifest or other shipping document serving a similar purpose and containing the information required by 172.202, 172.203, and 172.204 *[49 CFR 171.8]*

- Shipping documents includes all documents that are required by DOT and NRC regulations to accompany the shipment and any other information that OCRWM may wish to include for other purposes. The shipping documents are presented as a package to the carrier at the time the shipment is transferred to his custody. Shipping documents will include, but are not limited to, shipping paper, bill of lading, driver/train crew instructions for exclusive use, emergency response information, security and route plan, procedures, DOE/NRC Form 741, radiation records, load plans, spent fuel data, etc.
-
-

Table A1.2.3 Service and Maintenance Subsystem

ARCHITECTURE: Service and Maintenance Subsystems

REQUIREMENTS SATISFIED:

None identified at this time

RATIONALE:

- Inspection, maintenance, and repair of casks and associated transportation equipment will be an important part of future large-scale transportation operations. The DOE will develop rigid inspection criteria in coordination with the U.S. Department of Transportation (DOT) and periodic compliance testing procedures that the service contractors will be expected to adhere to and execute. The DOT will establish rigorous maintenance guidelines that are consistent with NRC and DOT requirements and will provide supervision to ensure that these guidelines are followed. Both scheduled and unscheduled maintenance capabilities for transportation equipment must be provided. It will be the responsibility of the service contractors to organize and implement the required inspection, maintenance and repair capabilities and to rigorously enforce quality assurance standards established by the DOE. In addition, OCRWM will audit and independently verify the acceptability of inspection and quality assurance actions. *[DOE/RW-0046, Section 5.1.4]*

- Provide a program of routine maintenance and inspection and where necessary, retesting to assure that all reusable containers used by DOE continue to meet the applicable design standards. *[DOE Order 5480.3, 9, b(7)]*

DESCRIPTION:

- Equipment and facilities will be provided to properly inspect, test and maintain the transportation subsystems to assure their availability and operability to perform their intended functions.
-
-

Table A1.2.3.1 Facilities Maintenance

ARCHITECTURE: Facilities Maintenance

REQUIREMENTS SATISFIED:

1.2.3.4P1

RATIONALE:

- To perform the functions of the transportation system a number of facilities will be required. These facilities may be independent or part of a larger multifunctional site. In order to insure the availability and operability of these facilities proper maintenance, will be required.

DESCRIPTION:

- All transportation system facilities will be routinely inspected and maintained in good working order, in accordance with industry practices and federal, state, and local codes and regulations.
-
-

Table A1.2.3.2 Cask Maintenance

ARCHITECTURE: Cask Maintenance

REQUIREMENTS SATISFIED:

1.2.3.4C1; 1.2.3.4P1; 1.2.3.4.1C2, 1.2.3.4.1C2; 1.2.3.4.1P1

RATIONALE:

- ... Such cask(s) shall be suitable for use at the purchaser's site, meet applicable regulatory requirements, and be accompanied by pertinent information
[10 CFR 961.11, Article IV, B, 2]

- (c) This general license applies only to a licensee who:

(1) Has a copy of the specific license, certificate of compliance, or other approval of the package and has the drawings and other documents referenced in the approval relating to the use and maintenance of the packaging and to the actions to be taken prior to shipment.

(2) Complies with the terms and conditions of the license, certificate of compliance, or other approval, as applicable and the applicable requirements of Subpart A, G, and H of this part

[10 CFR 71.12 (c)]

-
- As part of the Safety Analysis Report for Packaging, each applicant for NRC package approval must establish a maintenance program for the package. This maintenance program is reviewed by the NRC and is referenced in the Certificate of Compliance (CoC) as a condition of approval. In order to be in compliance with its CoC, a cask must be maintained in accordance with this maintenance program.

DESCRIPTION:

- Facilities and equipment will be provided to properly inspect, test and maintain casks in compliance with requirements.
-
-

Table A1.2.3.3 Transporter Maintenance

ARCHITECTURE: Transporter Maintenance

REQUIREMENTS SATISFIED:

None identified at this time

RATIONALE:

- Every motor carrier shall systematically inspect, repair, and maintain, or cause to be systematically inspected, repaired, and maintained all motor vehicles subject to its control. *[49 CFR 396.3 (a)]*
- This subpart contains safety requirements prohibiting a railroad from placing or continuing in service a freight car that has certain defective components. *[49 CFR 215.101]*
- All transporters shall be maintained so that they are in full compliance with applicable federal regulations and, for trailers, the applicable state regulations where the trailer is titled and registered.

DESCRIPTION:

- Facilities and equipment will be provided to properly inspect, test and maintain transporters in compliance with requirements.
-
-

Table A1.2.3.4 Prime Mover Maintenance

ARCHITECTURE: Prime Mover Maintenance

REQUIREMENTS SATISFIED:

None identified at this time

RATIONALE:

- Every motor carrier shall systematically inspect, repair, and maintain, or cause to be systematically inspected, repaired, and maintained all motor vehicles subject to its control. *[49 CFR 396.3 (a)]*
-
-

-
- This part prescribes minimum Federal safety standards for all locomotives except those propelled by steam power.

[49 CFR 229.1]

- All prime movers shall be maintained so that they are in full compliance with applicable federal regulations and, for tractors and other prime movers that require state licensing, the applicable state regulations where the trailer is titled and registered.

DESCRIPTION:

- Facilities and equipment will be provided to properly inspect, test and maintain prime movers in compliance with requirements.
-
-

Table A1.2.3.5 Ancillary Equipment Maintenance

ARCHITECTURE: Ancillary Equipment Maintenance

REQUIREMENTS SATISFIED:

1.2.3.4C1

RATIONALE:

- To perform the functions of the transportation system, ancillary equipment will be required. In order to insure the availability and operability of this ancillary equipment, proper maintenance will be required.

- Ancillary equipment will be periodically inspected and maintained in accordance with good industry practices and applicable Federal and State regulations.

DESCRIPTION:

- Facilities and equipment will be provided to properly inspect, test and maintain ancillary equipment in compliance with requirements.
-
-

Table A1.2.3.6 Equipment Documentation

ARCHITECTURE: Equipment Documentation

REQUIREMENTS SATISFIED:

1.2.3.4C1; 1.2.3.4.1C1

RATIONALE:

- Each licensee shall maintain sufficient written records to furnish evidence of the quality of packaging. The records to be maintained include ... results of maintenance, modification, and repair activities.

[10 CFR 71.91 (c)]

-
- Equipment and facilities, which are part of the transportation system, will be properly maintained and serviced to assure their availability and operability to perform the intended functions. Detailed records of all maintenance and servicing will be maintained to identify recurring problems or potential design deficiencies.

DESCRIPTION:

- Equipment and facilities will be provided to maintain required documentation.
-
-

Table A1.2.4 Field Operations Subsystem

ARCHITECTURE: Field Operations Subsystem

REQUIREMENTS SATISFIED:

None identified at this time

RATIONALE:

- In order to fulfill DOE's responsibilities under the NWPA and the Standard Contract, OCRWM will be required to provide technical assistance to various organizations.

DESCRIPTION:

- OCRWM will establish an organization to provide technical assistance to fulfill its legal, contractual, and regulatory responsibilities.
-
-

Table A1.2.4.1 Emergency Response Support

ARCHITECTURE: Emergency Response Support

REQUIREMENTS SATISFIED:

1.2.2.1.2C10, 1.2.2.1.2C19; 1.2.2.4.7C1, 1.2.2.4.7C3; 1.2.3.6.6.5C1 - 1.2.3.6.6.5C3

RATIONALE:

- No person to whom this subpart applies may offer for transportation, accept for transportation, transfer, store or otherwise handle during transportation a hazardous material unless:

(1) Emergency response information conforming to this part is immediately available for use at all times the hazardous material is present; and

(2) Emergency response information required by this subpart is immediately available to any person who, as a representative of a Federal, State, or local government agency, responds to an incident involving hazardous materials, or is conducting an investigation which involves a hazardous material

[49 CFR 172.600 (c)]

DESCRIPTION:

- In the event of an emergency, we will have certain responsibilities as the owner and shipper of the waste. In addition, the Department of Energy is the Federal agency to which Federal Radiological Emergency Response Plan assigns responsibility for providing Federal assistance for radiation monitoring and accident assessment. During normal operations of the system, we expect to maintain and supply information to the Department's emergency-management system on a continuous basis and respond to any request for support as soon as it is received from the emergency management system. Our emergency response actions are expected to be initiated through the cognizant Federal agencies and will follow the procedures outlined in the Federal Radiological Emergency Response Plan.

In response to an emergency situation, we will be prepared to provide technical assistance and equipment when requested through the State cognizant authority (State, Tribal, and local governments are generally responsible for providing the first response to a transportation accident). We will also provide any technical assistance that may be needed in later stages of the response. Finally, we will participate in activities needed for the recovery of the transportation system and assist in mitigation of consequences.

[DOE/RW-0316P, Section 6]

Table A1.2.4.2 Waste Acceptance Support

ARCHITECTURE: Waste Acceptance Support

REQUIREMENTS SATISFIED:

1.2.1.3C1; 1.2.1.4C1 - 1.2.1.4C3; 1.2.1.4I1 - 1.2.1.4I3, 1.2.1.4I5; 1.2.1.4O1 - 1.2.1.4O3

RATIONALE:

- DOE and the owners of spent nuclear fuel have entered into contracts (10 CFR 961) for the disposal of this material. Waste Acceptance is responsible for management and coordination under this contract. However, some key elements of DOE's contractual responsibilities fall under the transport waste system. As a result there must be close coordinations and support between the Accept Waste and Transport Waste functions.

DESCRIPTION:

- The Transport Waste function will provide technical support to the Accept Waste function in matters that are related to the transportation of spent fuel and high-level waste under the standard contract and/or memorandum of agreement (MOA).

Table A1.2.4.3 Purchaser/Producer/MRS/Repository Support

ARCHITECTURE: Purchaser/Producer/MRS/Repository Support

REQUIREMENTS SATISFIED:

1.2.3.5.1P1

RATIONALE:

- "DOE shall arrange for, and provide, a cask(s) and all necessary transportation of the SNF and/or HLW from the Purchaser's site to the DOE facility"

[10 CFR 961.11 Article IV, B, 2]

-
- DOE will be the shipper of record for all waste shipments to any Federal waste facility.

DESCRIPTION:

- As the provider of the cask and support equipment, DOE has a responsibility to provide technical assistance to the users of this equipment.
 - As shipper of record, DOE has a responsibility to verify that all shipments meet applicable DOT and NRC regulations, prior to providing the required written certification to DOT which is contained on the shipping papers.
-
-

Table A1.2.4.4 In-Transit Support

ARCHITECTURE: In-Transit Support

REQUIREMENTS SATISFIED:

1.2.2C6; 1.2.2.2.3C1; 1.2.3.6.4C1

RATIONALE:

- In order to fulfill DOE's responsibilities as the shipper of record, OCRWM will be required to provide technical support to the carrier, as necessary, while the waste shipments are in-transit.

DESCRIPTION:

- This support includes technical support in the event of abnormal occurrence such as equipment breakdown, vehicular conveyance replacement, etc.
-
-

Table A1.2.5 Planning & Control Subsystem

ARCHITECTURE: Planning & Control Subsystem

REQUIREMENTS SATISFIED:

None identified at this time

RATIONALE:

- A planning and control system is required to provide both short and long range system plans, to manage operations and equipment, to assure regulatory compliance, and to provide human resources for operations and support functions.

DESCRIPTION:

- The Planning and Control subsystem covers general management and support functions normally associated with most organizations as well as those functions unique to transport waste. These activities include planning, directing, controlling, reviewing, reporting, and coordinating.
-
-

Table A1.2.5.1 Engineering Services Support

ARCHITECTURE: Engineering Services Support

REQUIREMENTS SATISFIED:

1.2.3.3.2.5C2 - 1.2.3.3.2.5C4; 1.2.3.3.2.5P1; 1.2.3.3.2.5I1 - 1.2.3.3.2.5I4

RATIONALE:

• During the operation of the transport waste system, casks and other equipment will require maintenance, modifications and repairs. In order to accomplish these tasks, the transportation system will require an engineering support organization.

DESCRIPTION:

• Engineering service support will consist of expertise in cask and transporter design and fabrication.

Table A1.2.5.2 Quality Assurance Support

ARCHITECTURE: Quality Assurance Support

REQUIREMENTS SATISFIED:

1.2C13; 1.2.1.1C8; 1.2.3.3.5C1 - 1.2.3.3.5C20

RATIONALE:

• Each licensee shall establish, maintain and execute a quality assurance program satisfying each of the applicable criteria of 71.101 through 71.137 of this subpart and satisfy any specific provisions that are applicable to the licensee's activities, including procurement of packaging. The licensee shall apply each of the applicable criteria in a graded approach, i.e. to an extent that is consistent with its importance to safety.

[10 CFR 71.101 (b)]

• Prior to the use of any package for the shipment of licensed material subject to this subpart, each licensee shall obtain Commission approval of its quality assurance program.

[10 CFR 71.101 (c)]

DESCRIPTION:

• OCRWM has established a quality assurance program. The Quality Assurance Requirements Document (QARD) and the Quality Assurance Program Description (QAPD) describe the OCRWM QA Program and will be applied to all required activities relating to the transport of spent nuclear fuel and high-level waste. After its review of both the QARD and QAPD, the NRC found these documents as acceptable in meeting the requirements of 10 CFR 71 Subpart H. The NRC approval of OCRWM's QA plan for transportation of spent fuel and high-level waste is contained in a letter from John J. Lineham of the NRC's Office of Nuclear Material Safety and Safeguards to Dwight E. Shelor of OCRWM's Office of Systems and Compliance dated April 15, 1991.

Table A1.2.5.3 Campaign and Operations Planning

ARCHITECTURE: Campaign and Operations Planning

REQUIREMENTS SATISFIED:

1.2.2C9 - 1.2.2C11; 1.2.2.1.2C19; 1.2.3.1C1, 1.2.3.1C2; 1.2.3.1.1C1 - 1.2.3.1.1C7; 1.2.3.1.2C1

RATIONALE:

- In order to ensure that the transportation system will be ready to provide service when required, a detailed planning organization will be needed.

DESCRIPTION:

- Operational planning will cover both ongoing transportation operations and operations projected over the life of the system.
 - Long-range transportation planning will provide input for OCRWM's waste acceptance from the owners. It will also be used to determine the size of the cask fleet, to determine transportation modes, and to identify requirements for acquiring or replacing cask systems.
 - Integrated campaign planning will be conducted for shipping campaigns to effectively use transportation resources. An important planning function involves coordination of transportation schedules with the waste generators and other elements of OCRWM's waste management system.
-
-

Table A1.2.5.4 Operations Management

ARCHITECTURE: Operations Management

REQUIREMENTS SATISFIED:

1.2.2C9 - 1.2.2C11; 1.2.2.4C1; 1.2.2.4O3, 1.2.2.4O4; 1.2.2.4.1C1; 1.2.2.4.2C1 - 1.2.2.4.2C5; 1.2.2.4.4C1; 1.2.2.4.7C1, 1.2.2.4.7C3; 1.2.3.1C2; 1.2.3.6.6C1; 1.2.3.6.6.5C1 - 1.2.3.6.6.5C3

RATIONALE:

- In order to fulfill DOE's responsibility as the shipper of record, OCRWM will be required to manage the operations of the transportation system, manage traffic and manage inventories of casks, vehicular conveyances, equipment and spare parts and consumables.

DESCRIPTION:

- Facilities, equipment and human resources will be provided to provide the above mentioned functions. Included will be a central traffic control facility, warehouse facilities and equipment storage facilities.
-
-

Table A1.2.5.5 Regulatory Compliance Support

ARCHITECTURE: Regulatory Compliance Support

REQUIREMENTS SATISFIED:

1.2.2C2; 1.2.2.1.2C2; 1.2.2.4.2C1 - 1.2.2.4.2C5; 1.2.2.4.6C1; 1.2.3.2C1 - 1.2.3.2C13;
1.2.3.6.6.4C1

RATIONALE:

- In order to fulfill DOE's responsibilities as the shipper of record, OCRWM will be required to continually provide regulatory compliance information which will necessitate a regulatory compliance support organization.

DESCRIPTION:

- To facilitate compliance with transportation regulations and to guide and control transportation activities, we will develop a detailed set of operating procedures. These procedures will specify how the casks are to be loaded and handled, how they are to be inspected, and how they are to be maintained. In developing these procedures we will work closely with the waste generators to resolve any technical issues well in advance of shipments.
[DOE/RW-0316P, Section 6]
-
-

Table A1.2.5.6 Administration Support

ARCHITECTURE: Administration Support

REQUIREMENTS SATISFIED:

1.2.2.4C1; 1.2.2.4O3, 1.2.2.4O4; 1.2.2.4.2C1 - 1.2.2.4.2C5; 1.2.3.3.2.5C2 - 1.2.3.3.2.5C4;
1.2.3.3.2.5P1; 1.2.3.3.2.5I1 - 1.2.3.3.2.5I4

RATIONALE:

- An administrative support organization will be required to support transportation operations.

DESCRIPTION:

- The administration support organization shall include financial accounting, human resources, information management, procurement, and public information resources.
-
-

Table A1.2.5.7 Training Support

ARCHITECTURE: Training Support

REQUIREMENTS SATISFIED:

1.2.2.4.7C4; 1.2.3.3.2.4C1 - 1.2.3.2.4C4; 1.2.3.3.2.4P1

RATIONALE:

• ... Such cask(s) shall be suitable for use at the purchaser's site, meet applicable regulatory requirements, and be accompanied by pertinent information including but not limited to the following:

(b) Training for purchaser's personnel in cask handling and loading as may be necessary.

[10 CFR 961.11 Article IV, B, 2]

• ... It is the duty of each person who offers hazardous materials for transportation to instruct each of his officers, agents, and employees having any responsibility for preparing hazardous materials for shipment as to the applicable regulations in this subchapter.

[49 CFR 173.1 (b)]

DESCRIPTION:

• In developing its transportation program, the DOE assumes the major responsibility of establishing rigorous guidelines for personnel training related to waste shipments. The DOE will establish training guidelines consistent with NRC and DOT requirements that contribute to operational safety and that reinforce public confidence in the transportation system. Training comprises many elements including the instruction of drivers, maintenance and service mechanics, inspectors and security personnel, and emergency response organizations. Once guidelines are established, the DOE will ensure that training will be conducted by the service contractors in accordance with NRC and DOT requirements. When appropriate and approved by DOE, training may be conducted by separate private organizations. This is particularly true where independence is deemed necessary. The DOE will oversee training activities and update guidelines as required.

[DOE/RW-0046, Section 5.1.3]

Table A1.2.5.8 Security Support

ARCHITECTURE: Security Support

REQUIREMENTS SATISFIED:

1.2.2C13, 1.2.2C14; 1.2.2.1.3C1; 1.2.2.2.4C1, 1.2.2.2.4C2, 1.2.2.2.4C4, 1.2.2.2.4C5; 1.2.2.4.4C1

RATIONALE:

• Another element in our transportation planning is the physical security of spent-fuel shipments. In 10 CFR Part 73, "Physical Protection of Plants and Materials," the Nuclear Regulatory Commission has established specific regulatory requirements for the protection and safeguarding of these shipments. Our shipments will be in full compliance with the requirements of the Commission.

[DOE/RW-0316P, page 115]

DESCRIPTION:

• ... the physical protection shall:

(i) Provide for early detection and assessment of attempts to gain unauthorized access to, or control over, spent fuel shipments;

(ii) Provide for notification to the appropriate response forces of any spent fuel shipment sabotage attempts; and

(iii) Impede attempts at radiological sabotage or spent fuel shipments within heavily populated areas, or attempts to illicitly move such shipments into heavily populated areas, until response forces arrive.

[10 CFR 73.37(a)(2)]

Table A1.2.5.9 Records and Information Management Support

ARCHITECTURE: Records and Information Management Support

REQUIREMENTS SATISFIED:

1.2.2.4.2C1, 1.2.2.4.2C4; 1.2.2.4.4C1; 1.2.2.4.7C4; 1.2.2.4.8C1 1.2.3.3.2.1C1 - 1.2.3.3.2.1C9

RATIONALE:

- Each licensee shall maintain sufficient written records to furnish evidence of the quality of the packaging. The records to be maintained include results of the determinations required by 71.85; design fabrication and assembly records; results of reviews, inspections, tests, and audits; results of maintenance, modification, and repair activities. Inspection, test and audit records must identify the inspector or data recorder, the type of observation, the results, the acceptability and action taken in connection with any deficiencies noted. The records must be retained for three years after the life of the packaging to which they apply. [10 CFR 71.89 (c)]

- The licensee shall make available to the Commission for inspection, upon reasonable notice, all records required by this part. Records are only valid if stamped, initialed, or signed and dated by authorized personnel or otherwise authenticated [10 CFR 71.89 (b)]

- Each record required by this part must be legible throughout the retention period specified by each commission regulation. The record must be the original or a reproduced copy or a microform provided that the copy or microform is authenticated by authorized personnel and that the microform is capable of producing a clear copy throughout the required retention period. The records may also be stored in electronic media with the capability for producing legible, accurate, and complete records during the required retention period. Records such as letters, drawings, specifications, must include all pertinent information such as stamps, initials, and signatures. The licensee shall maintain adequate safeguards against tampering with and loss of records. [10 CFR 71.1 (b)]

DESCRIPTION:

- A records management system must be established to provide for the maintenance, security, and accessibility of all required records.
 - The records will be maintained on a cask specific basis for the life of each cask in the cask fleet.
 - The records management system must comply with the requirements of the OCRWM QA Program for the maintenance and security of QA records.
 - Equipment and facilities will be provided to maintain required records and information.
-
-

4.0 INTERFACES

Interfaces can indicate either a flow between functions as in a sequence of activities, or a necessary fit between architectures. They are also either internal interfaces which are contained entirely within the function structure or external interfaces which interact with functions outside of the function structure. Prior to the preparation of detailed designs, only interfaces that indicate a flow between functions can be explicitly described.

Figures 6-10 show the interfaces, both internal and external, at the various levels within the function hierarchy. As depicted in these N-Square charts, functions are located on the diagonal, and interfaces are represented as either inputs to a particular function (those items located vertically above or below a function), or outputs from a particular function (those items located horizontally to the right or left of a function). The requirements for each of these interfaces are contained in Tables F1. - F1.2.3.7.4.

A more visual display of the interfaces is illustrated in the functional flow diagrams (Figures 11-16). Interfaces enter or exit a box containing a function as either inputs or outputs (see legend on illustration). A compilation of key inputs and outputs of the Transport Waste function are provided in Appendix E. Inputs and outputs from functions below the third level are not shown in Appendix E, however, these can be seen in both the N-Square charts and functional flow diagrams. Each interface is automatically tracked through lower level functional flow diagrams, thus assuring both traceability and consistency in logic and material flows. However, to maintain legibility on these diagrams, only key inputs/outputs, addressing the most important concepts at a particular function level, are explicitly shown on each diagram. Therefore, inputs and outputs not shown on lower level diagrams are bracketed (i.e. tunnelled) on the higher level functions and vice versa. Also, only the important controls and resources are shown at each level.

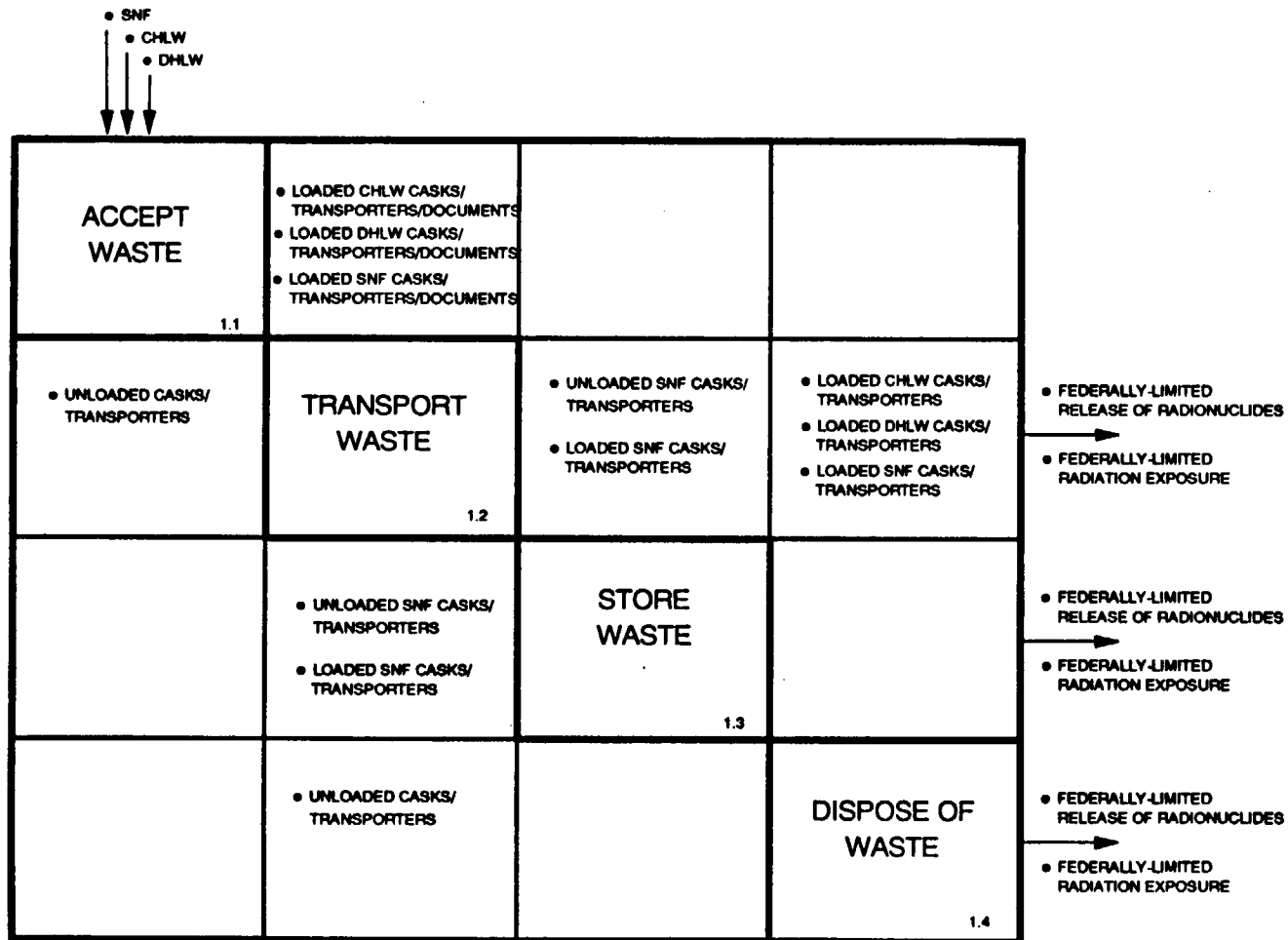
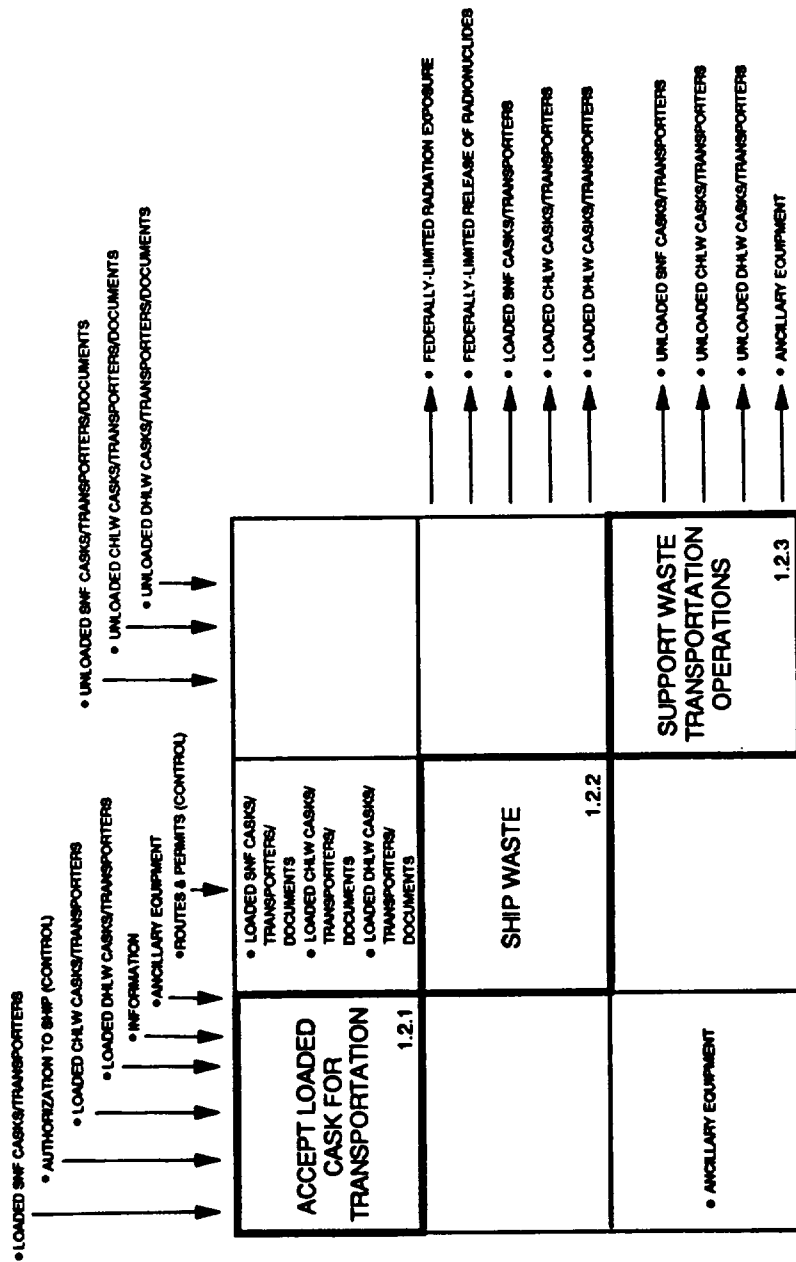

Figure 6. N-Square Chart for Second Level Functions



MSDS 11/1982

Figure 7. N-Square Chart for 1.2 Transport Waste

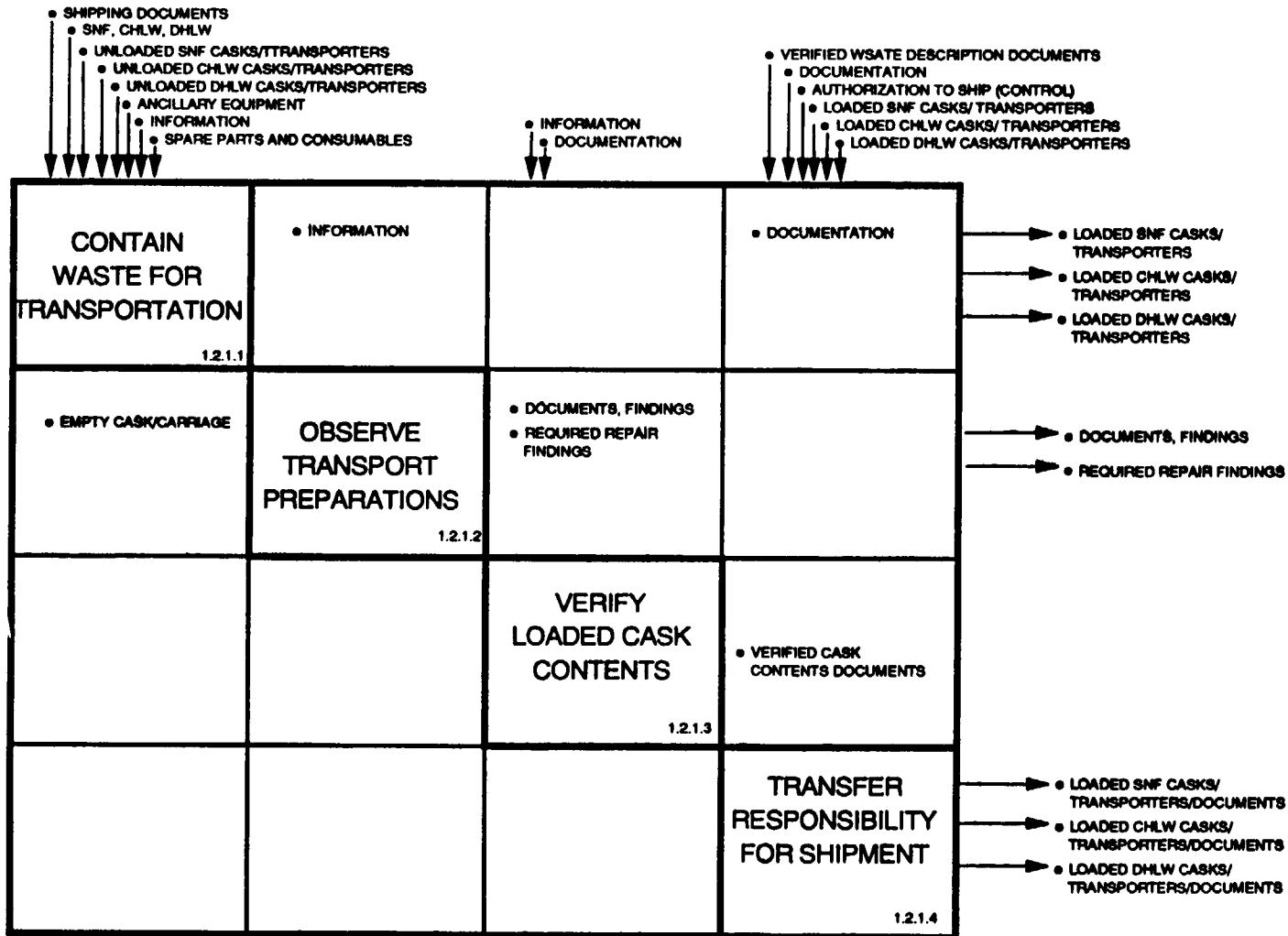

Figure 8. N-Square Chart for 1.2.1 Acceptance for Transportation

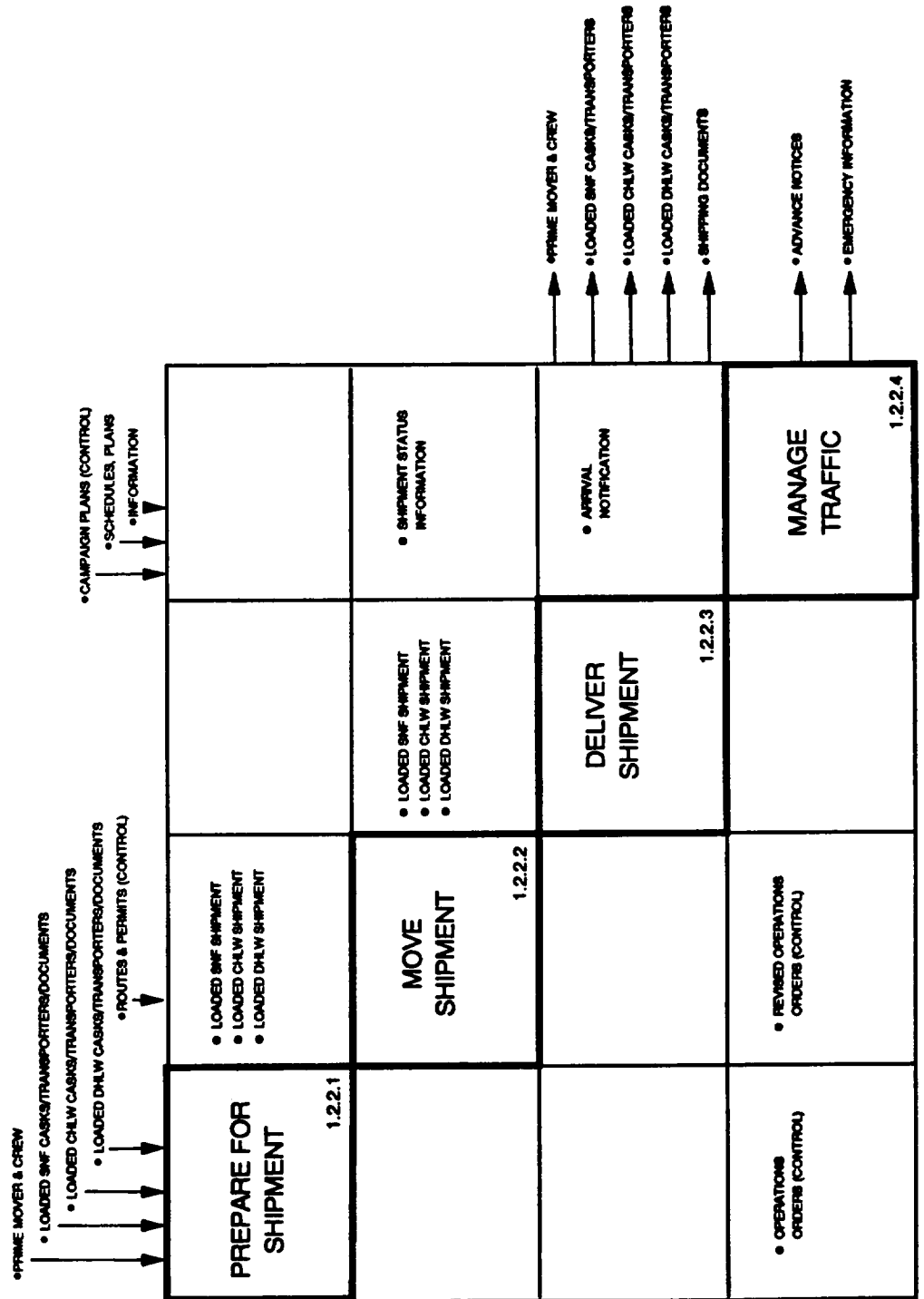

Figure 9. N-Square Chart for 1.2.2 Ship Waste

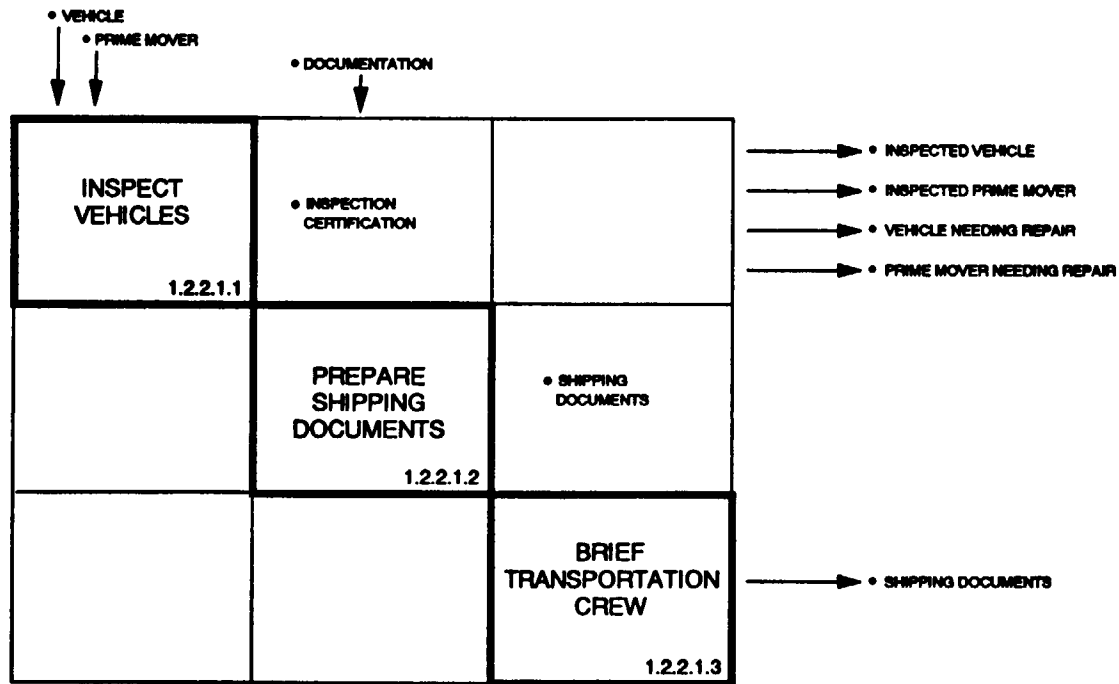

Figure 10. N-Square Chart for 1.2.2.1 Prepare for Shipment

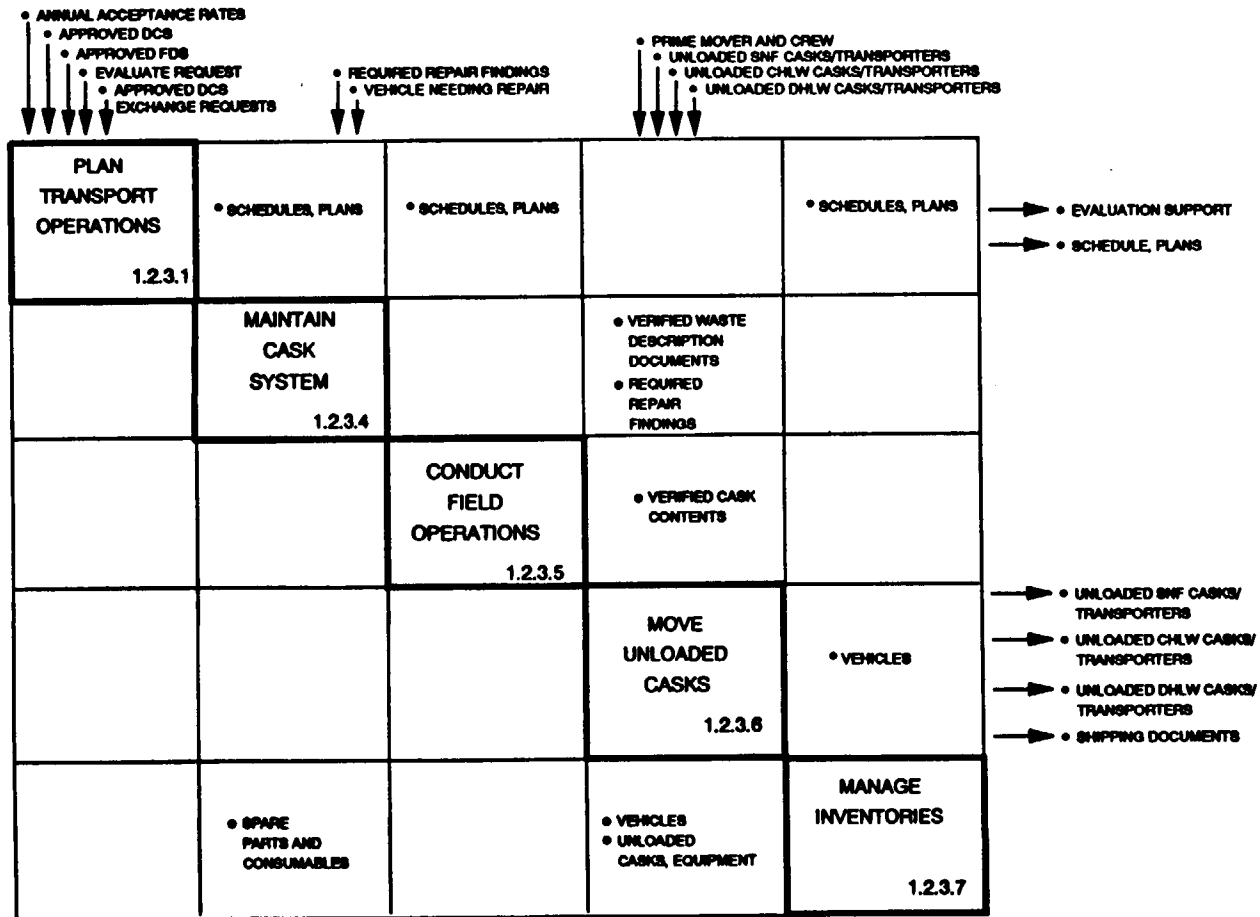

Figure 11. N-Square Chart for 1.2.3 Support Waste Transportation Operations

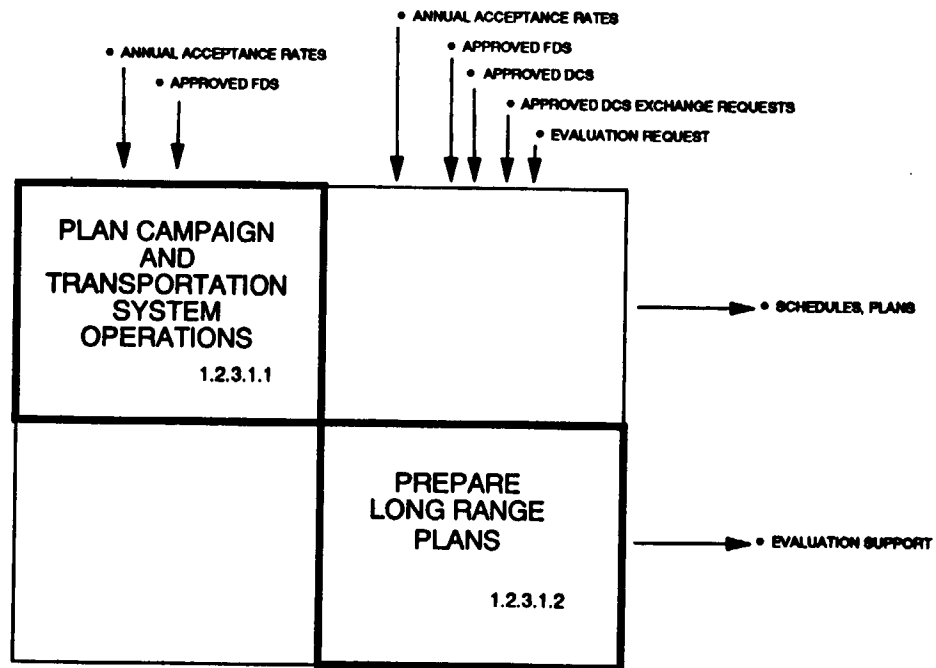
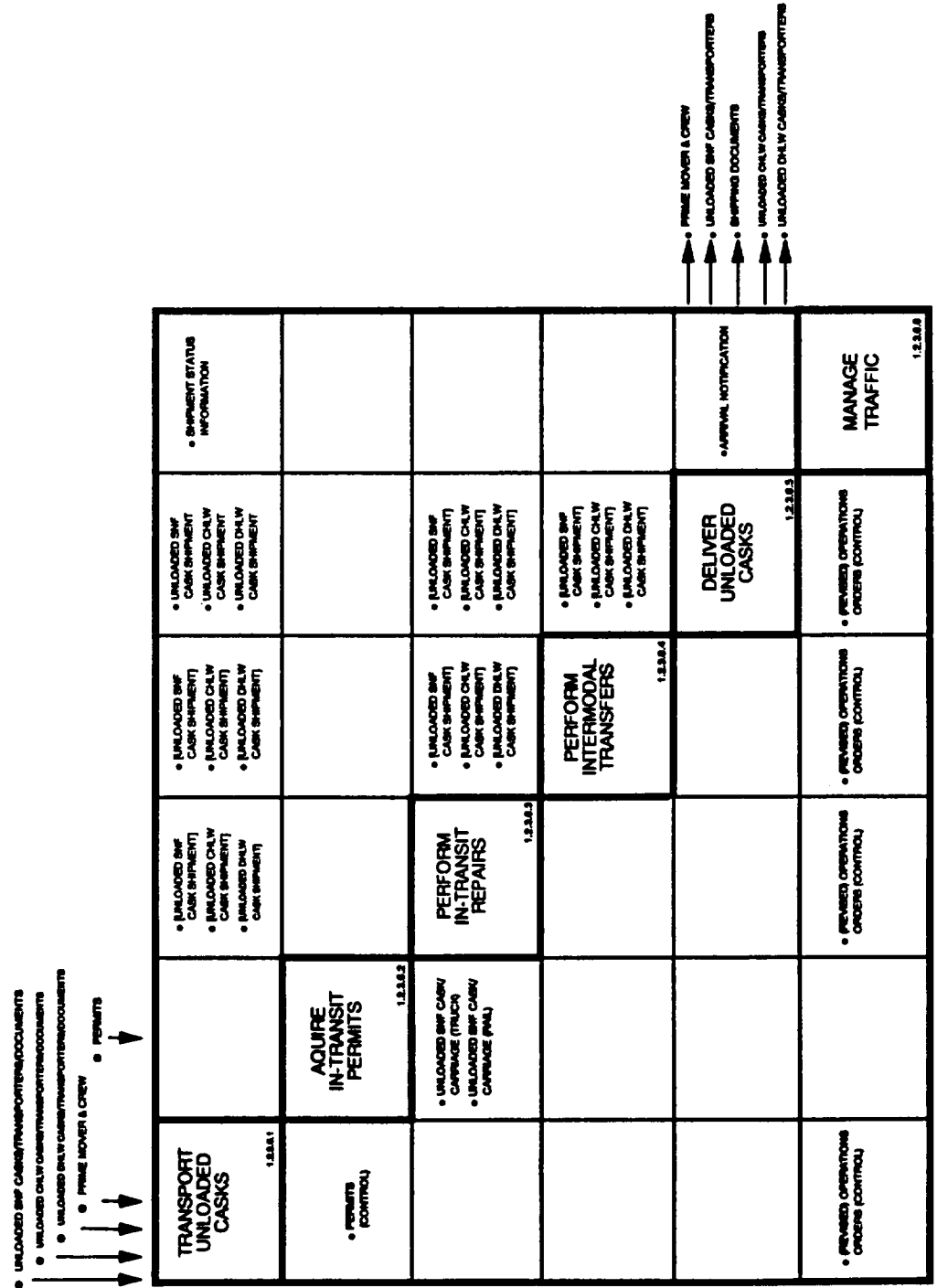

Figure 12. N-Square Chart for 1.2.3.1 Plan Transport Operations



11/19/02

Figure 13. N-Square Chart for 1.2.3.6 Move Unloaded Casks

(1) If Required

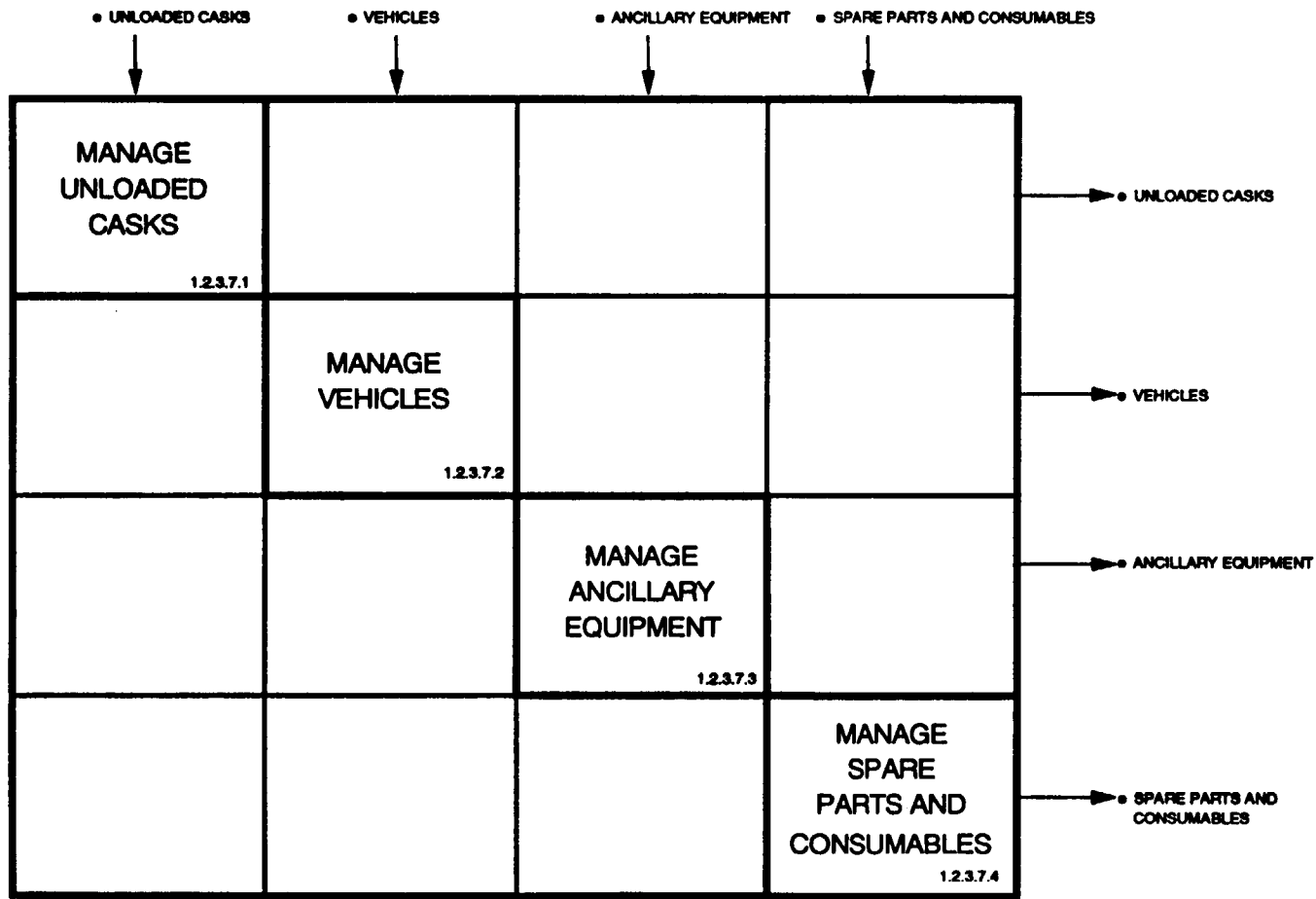

Figure 14. N-Square Chart for 1.2.3.7 Manage Inventories

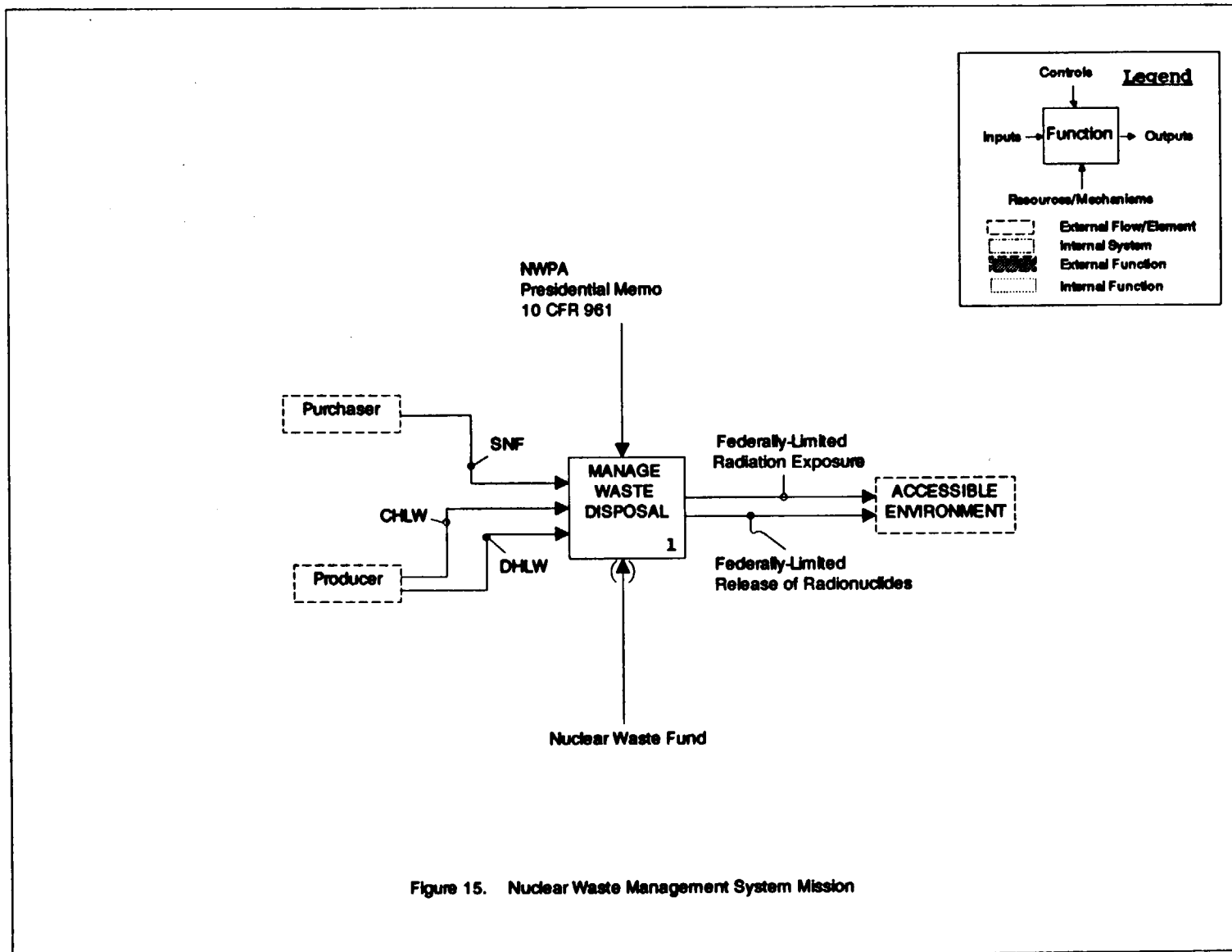

Figure 15. Nuclear Waste Management System Mission

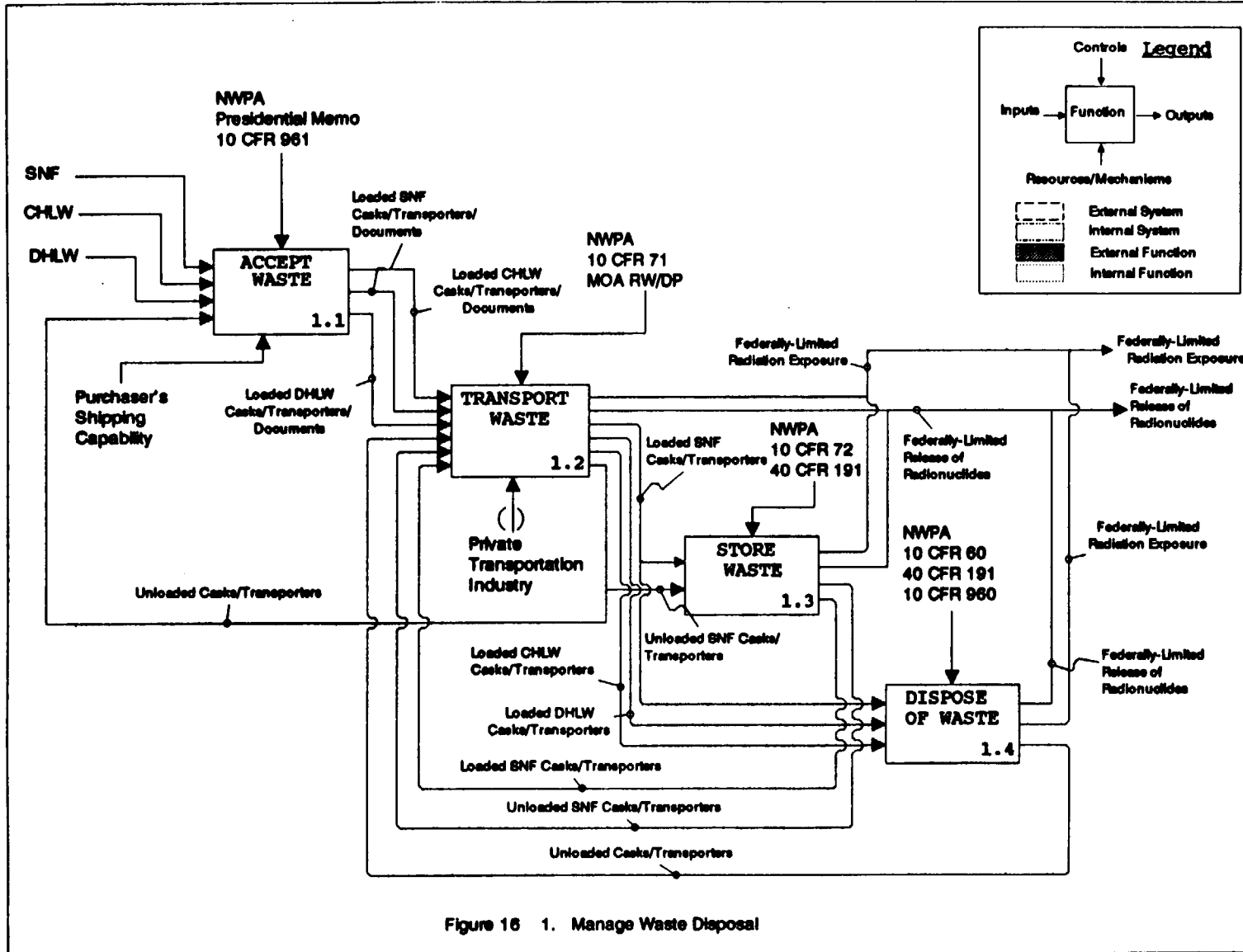

Figure 16 1. Manage Waste Disposal

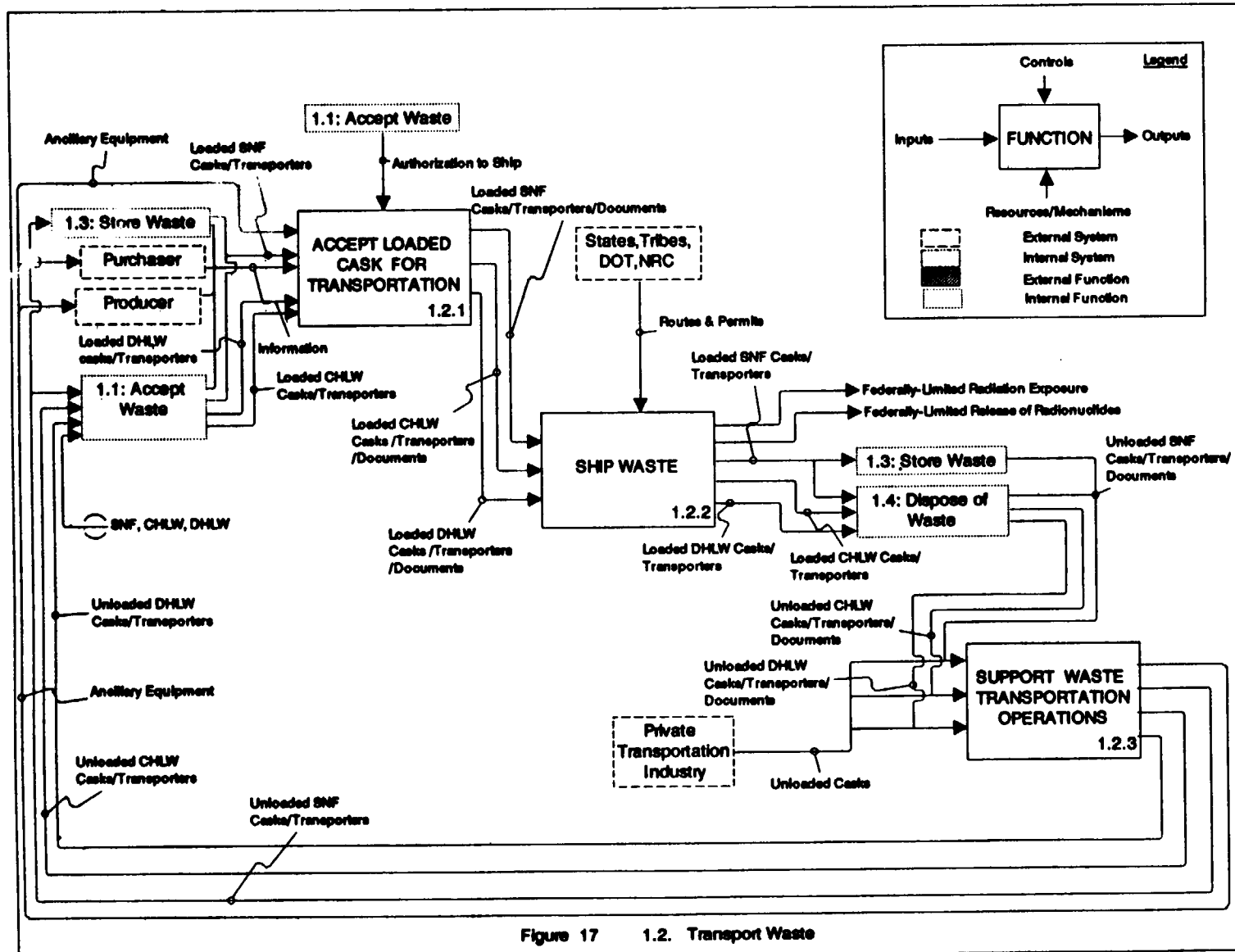
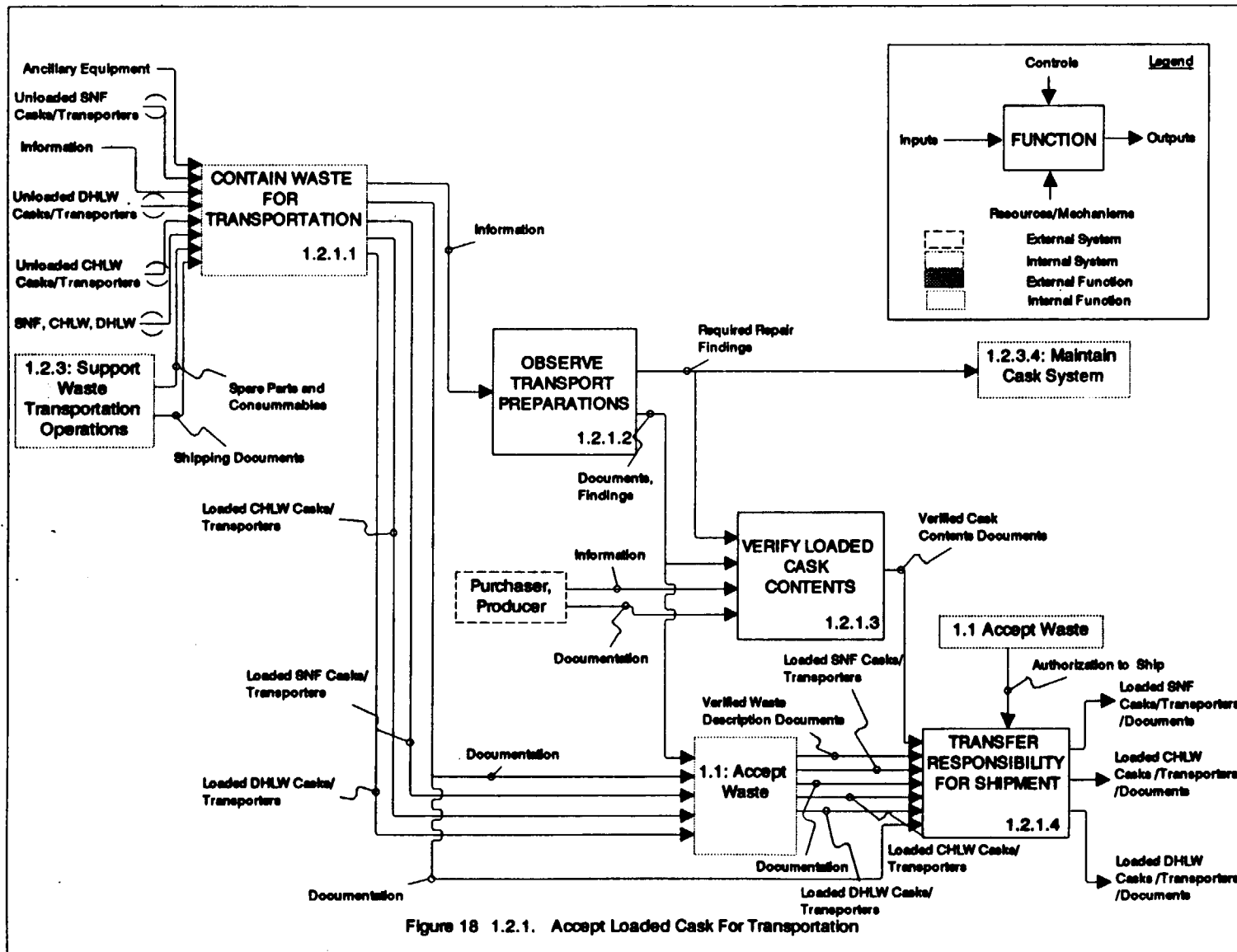

Figure 17 1.2. Transport Waste



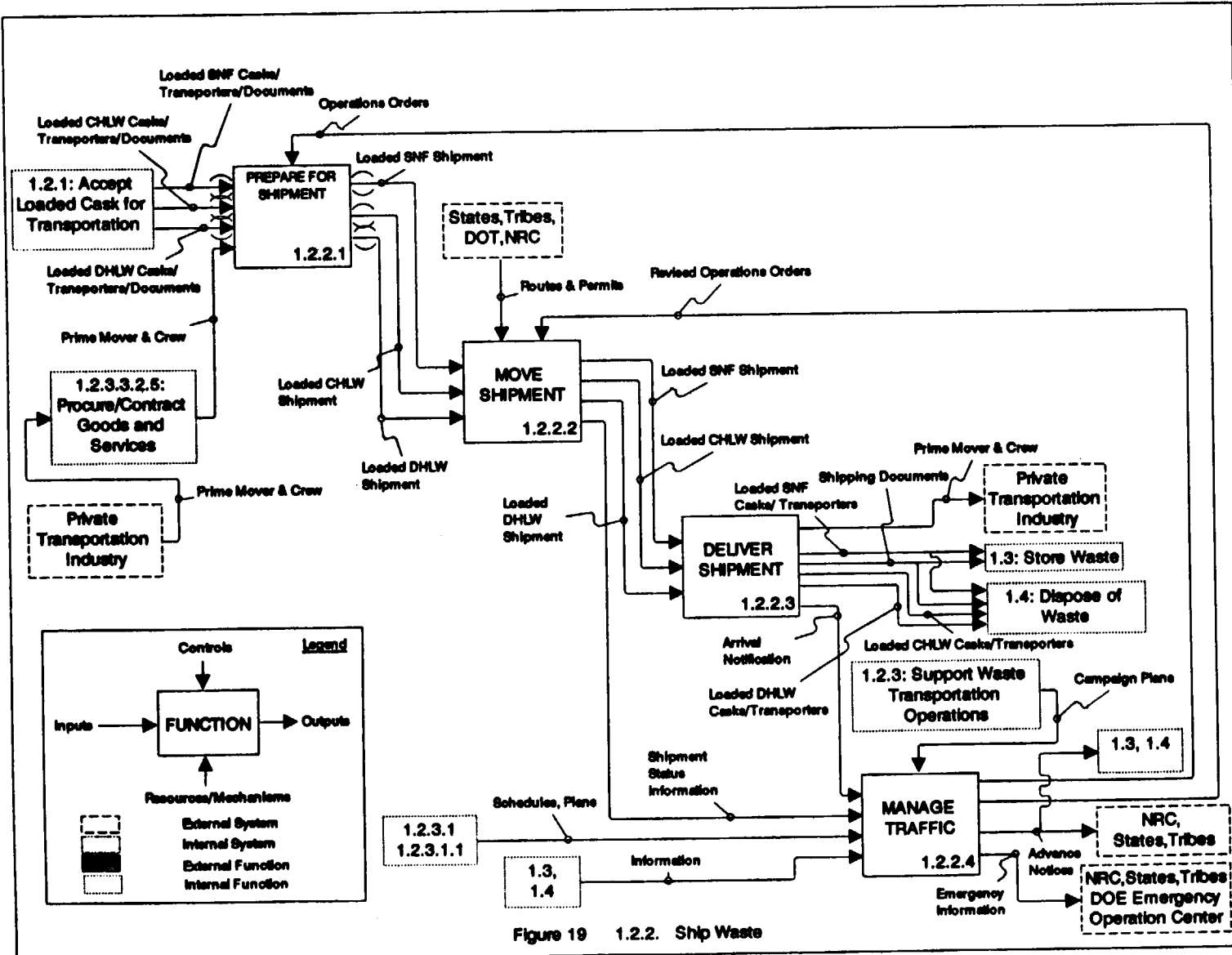

Figure 19 1.2.2. Ship Waste

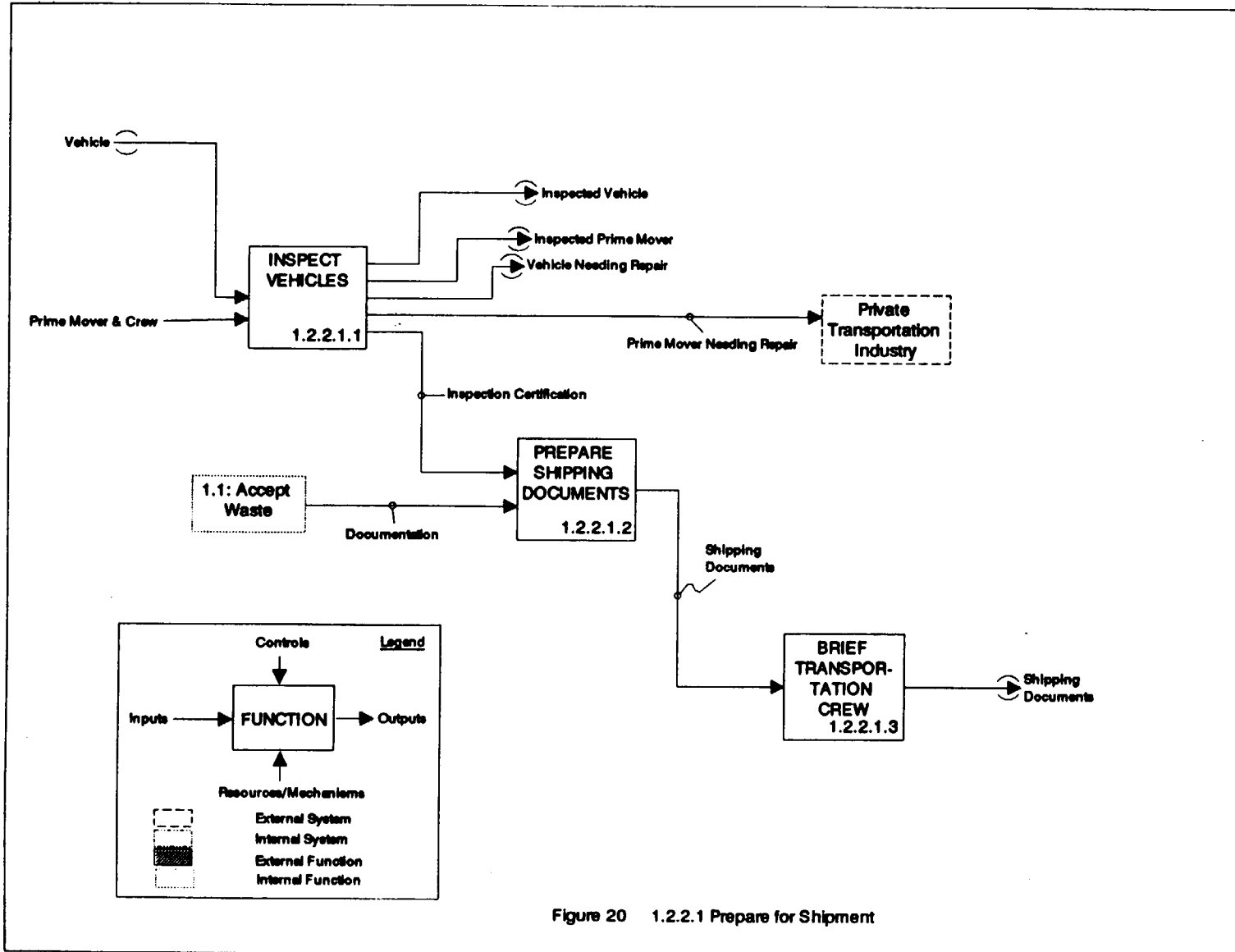

Figure 20 1.2.2.1 Prepare for Shipment

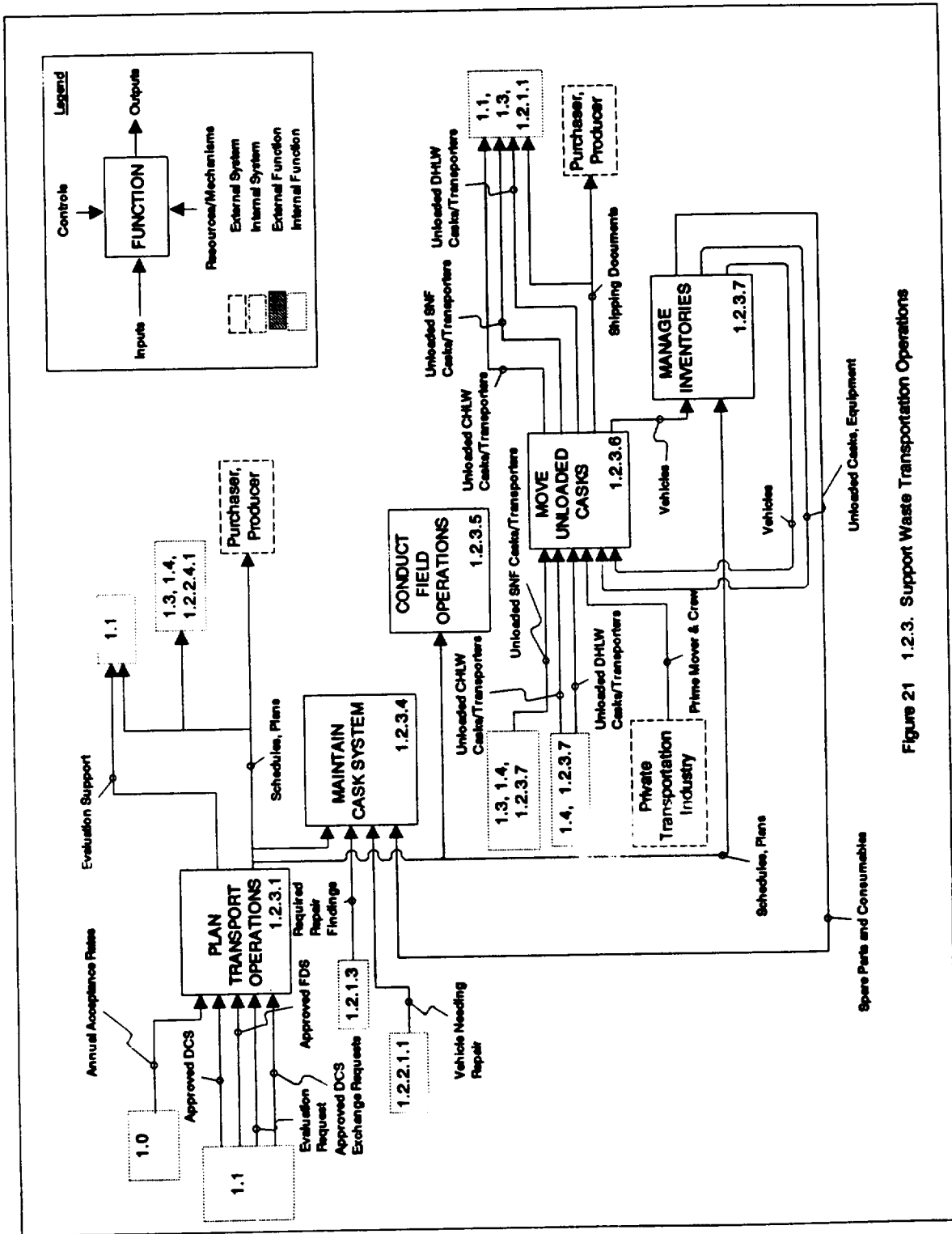

Figure 21 1.2.3. Support Waste Transportation Operations

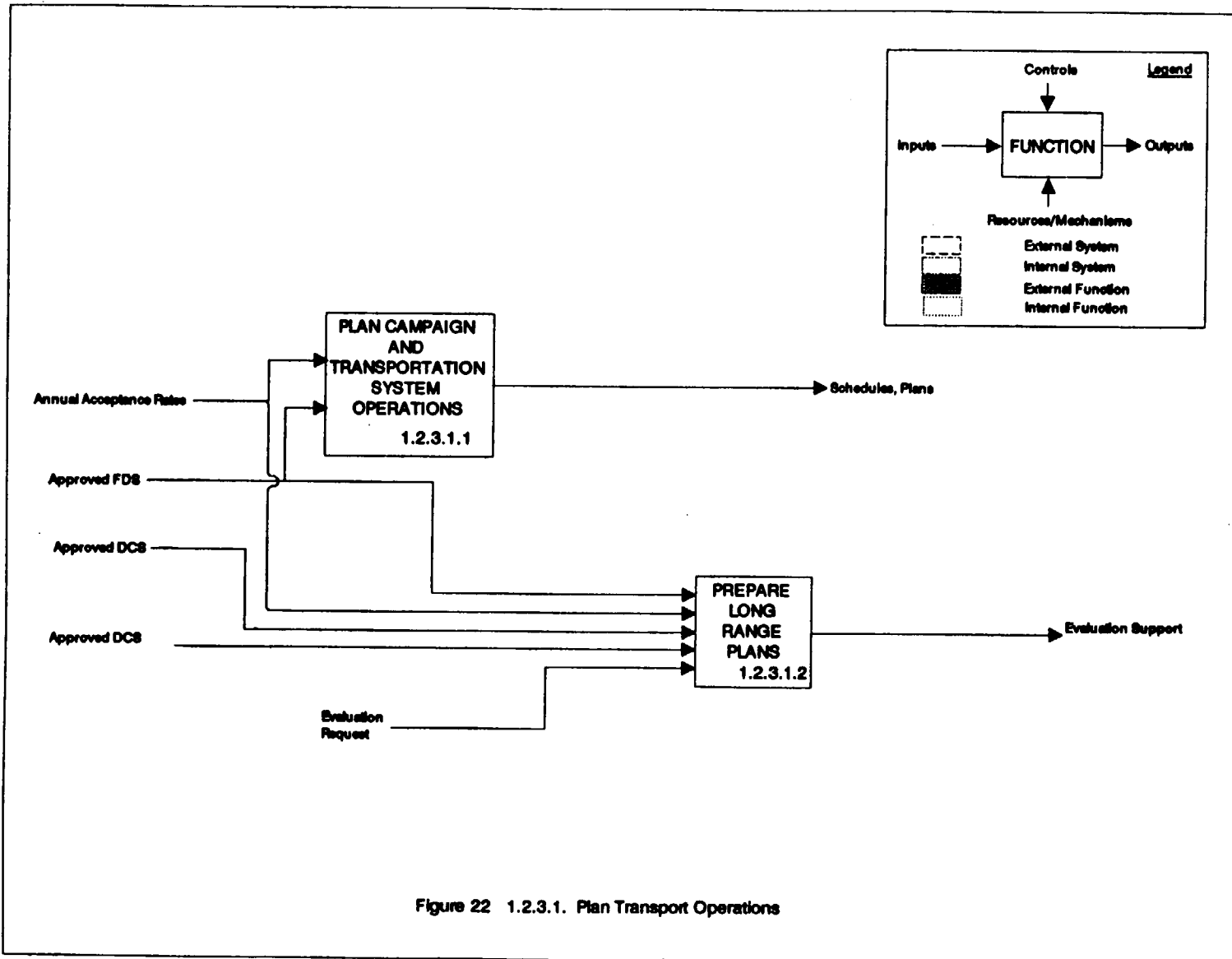

Figure 22 1.2.3.1. Plan Transport Operations

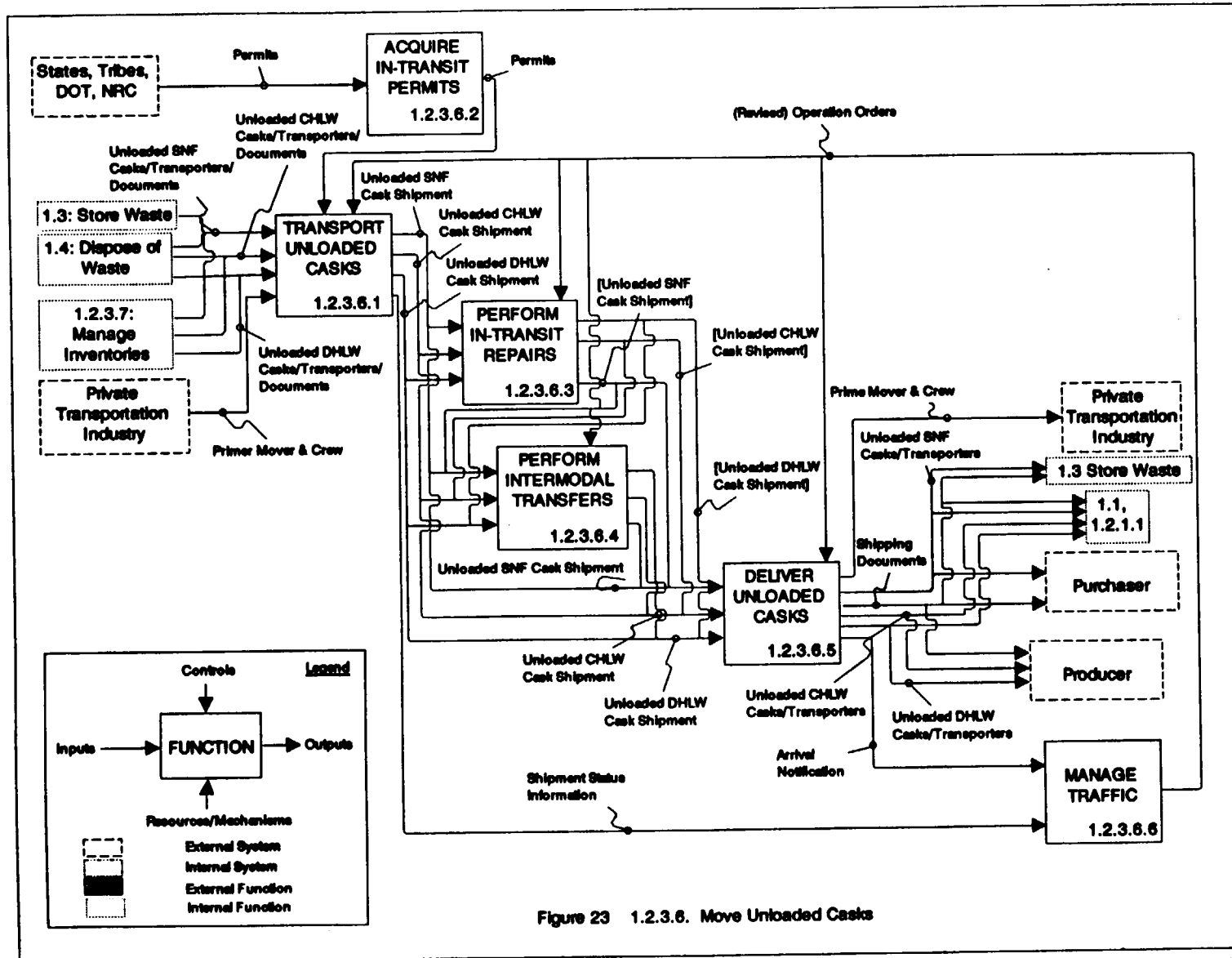

Figure 23 1.2.3.6. Move Unloaded Casks

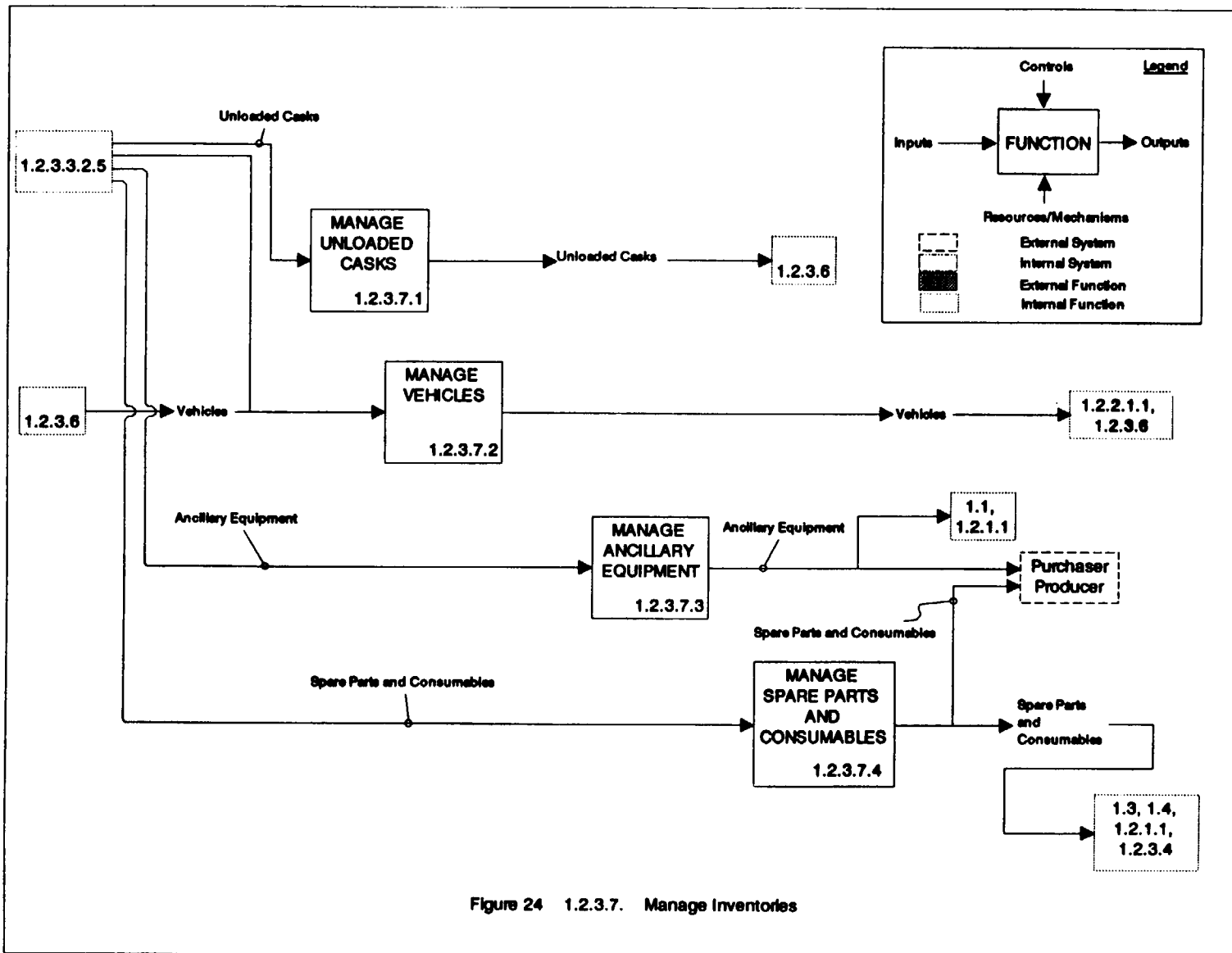

Figure 24 1.2.3.7. Manage Inventories

APPENDICES

APPENDIX A

GLOSSARY

This glossary contains definitions for the various terms used throughout this report and references for those terms that have been previously defined in one or more source documents.

As Low As Reasonably Achievable (ALARA) - As low as is reasonably achievable taking into account the state of technology, and the economics of improvement in relation to-

- (1) Benefits to the public health and safety,
- (2) Other societal and socioeconomic considerations, and
- (3) The utilization of atomic energy in the public interest. [10 CFR 72.3]

Accessible Environment - (1) The atmosphere, (2) the land surface, (3) surface water, (4) oceans, and (5) the portion of the lithosphere that is outside the controlled area. [10 CFR 60.2]

Architecture - That part of the physical system actually built, found, or selected to perform a function subject to its stated requirements.

Burnup - A measure of nuclear reactor fuel consumption expressed as the amount of energy produced per unit weight of fuel.

Campaign - The sequential shipments of spent nuclear fuel or high-level waste from a single generator's facility to a single Nuclear Waste Management System receiving facility. A shipping campaign begins with precampaign planning which includes the development of site specific operating procedures, cask handling training, and the development of site specific equipment, if required. Also included in the normal shipping campaign is the mobilization of OCRWM provided equipment and personnel at the generating site, on-site preshipment activities, movement of the spent nuclear fuel or high-level waste, and the delivery of empty casks. The shipping campaign ends with the demobilization of OCRWM provided equipment and personnel for the specific site. The size of a shipping campaign normally will be determined by the annual quantity of spent nuclear fuel or high-level waste to be delivered.

Canister - The metal receptacle with the following purpose: 1) for solidified HLW, its purpose is a pour mold and 2) for spent fuel, it may provide structural support for loose rods or containment of radionuclides.

Carrier - A person engaged in the transportation of passengers or property by land or water as a common, contract, or private carrier, or by civil aircraft. [10 CFR 71.4]

Cask - See package.

Cask System - As a minimum, it shall include the complete cask, a truck trailer or rail car (defined as the transporter), a tiedown system, an intermodal transfer device, special tools, and ancillary equipment. [RFP No. DE-rp07-86ID12625 Development of From-Reactor Casks]

Certificate of Compliance (CoC) - A certificate issued by DOE or the Nuclear Regulatory Commission, as appropriate, approving for use, with identified limitations, a specific packaging for quantities of radioactive materials exceeding A1/A2 quantities as defined in 49 CFR 173 and 10 CFR 71. [DOE Order 1540.3, Section 4.a]

Commercial High-Level Radioactive Waste (CHLW) - The high-level radioactive waste, as defined by NWSA Sec. 2(12), resulting from atomic energy civilian activities.

Commission - The Nuclear Regulatory Commission or its duly authorized representatives. [10 CFR 60.2]

Consolidation - The operation performed on spent fuel assemblies during which the upper and lower fuel-assembly tie plates are removed, the assembly spacer grids and any other assembly structural members are removed, and the fuel tubes are collected and formed into a closely packed bundle in a canister or container. The nonfuel structural members of the fuel assemblies are reduced in volume and placed in canisters or containers for shipment and disposal. [DOE/RW-0199, Vol. VIII, Part B, page G-18]

Constraint - A requirement imposed by the external environment (e.g., NRC).

Container - The component of the waste package that is placed around the waste form or the canistered waste form.

Containerize - To place the waste form or the canisterized waste in a container for emplacement.

Control - See constraint.

Defense High-Level Radioactive Waste (DHLW) - The high-level radioactive waste, as defined by NWSA Sec. 2(12), resulting from atomic energy defense activities.

Department - The Department of Energy

Disposal Package or Waste Package - The primary container that holds, and is in contact with, solidified high-level radioactive waste, spent nuclear fuel, or other radioactive materials, and any overpacks that are emplaced at a repository. [NWSA Sect. 2(10)]

Function - A primary statement of purpose; definition of what a system or subsystem must accomplish to meet the system mission.

Functional Analysis - The first step in the Systems Engineering process that defines a baseline of functions and function performance requirements which must be met in order to adequately accomplish the operation, support, test, and production requirements of a system. [DSMC 6.1]

Functional Interface - The interaction between functions, as in the flow of material or information between a sequence of activities.

Geologic Repository - A system which is intended to be used for, or may be used for, the disposal of radioactive wastes in excavated geologic media. A geologic repository includes: (1) the geologic repository operations area, and (2) the portion of the geologic setting that provides isolation of the radioactive waste. [10 CFR 60.2]

- A system, requiring licensing by the NRC, that is intended to be used, or may be used, for the disposal of radioactive waste in excavated geologic media. A geologic repository includes (1) the geologic repository-operations area and (2) the portion of the geologic setting that provides isolation of the radioactive waste and is located within the controlled area. [10 CFR 960.2]

- The Term "repository" means any system licensed by the Commission that is intended to be used for, or may be used for, the permanent deep geologic disposal of high-level radioactive waste and spent nuclear fuel, whether or not such system is designed to permit the recovery, for a limited period during initial operation, of any materials placed in such system. Such term includes both surface and subsurface areas at which high-level radioactive waste and spent nuclear fuel handling activities are conducted. "Disposal System" means any combination of engineered and natural barriers that isolate spent nuclear fuel or radioactive waste after disposal.

High-level Radioactive Waste - (A) the highly radioactive material resulting from the reprocessing of spent nuclear fuel, including liquid waste produced directly in reprocessing and any solid material derived from such liquid waste that contains fission products in sufficient concentrations; and (B) other highly radioactive material that the Commission, consistent with existing law, determines by rule requires permanent isolation. [NWSA Sect. 2(12)]

- (1) Irradiated reactor fuel, (2) liquid wastes resulting from the operation of the first cycle solvent extraction system, or equivalent, and the concentrated wastes from subsequent extraction cycles, or equivalent, in a facility for reprocessing irradiated reactor fuel, and (3) solids into which such liquid wastes have been converted. [10 CFR 60.2]

HLW Facility - A facility subject to the licensing and related regulatory authority of the Commission pursuant to Section 202(3) and 202(4) of the Energy Reorganization Act of 1974 (88 Stat. 1244). [10 CFR 60.2]

Important to Safety - Structures, components, and systems whose failure or malfunction could result directly or indirectly in a condition adversely affecting public health and safety. [Reg. Guide 7.10, Appendix A]

Input - Anything that is acted upon by a function to produce desired outputs. Inputs can be classified as either internal or external. Inputs that originate from outside a particular system are considered to be external. Inputs that are outputs from functions within a particular system are considered to be internal.

Interface Requirements - A requirement which applies to the inputs to, or outputs from, the function.

Licensee - A person who is authorized to conduct activities under a license or construction permit issued by the Commission. [10 CFR 2.4]

NOTE: In 10 CFR 71 two separate activities are addressed. The first activity is the delivery to a carrier for transport or the transport of radioactive material. 10 CFR 71.3 specifically requires these activities to be covered either by a specific or general license issued by the commission. The second activity is the NRC certification of a package design for use. These activities are covered by a Certificate of Compliance (license) which is issued to a specific person who is identified in section 3 of the C of C. In some instances these two activities are conducted by the same person (licensee). In other instances a licensee (licensee-user) will deliver to a carrier for transport in a package which is owned by another licensee. In this instance the NRC holds the licensee-use responsible to insure that all of its transportation activities meet the requirements of 10 CFR 71, even those normally associated with cask ownership. See IE Information Notice No. 83-10: "Clarification of Several Aspects Relating to Use of NRC-Certified Transport Packages" for additional information.

Management - Any activity, operation, or process (except for transportation) conducted to prepare spent nuclear fuel or radioactive waste for storage or disposal, or the activities associated with placing such fuel or waste in a disposal system. [40 CFR 191.01(m)]

Nuclear Waste Management System - (NWMS) - Consists of the composite of the sites, and all facilities, systems, equipment, materials, information, activities, and the personnel required to perform those activities necessary to manage waste disposal.

Output - Anything that leaves the system or function after it has been acted upon by that function.

Package - The packaging together with its radioactive contents as presented for transport. [10 CFR 71.4]

Packaging - The assembly of components necessary to ensure compliance with the packaging requirements of this part. It may consist of one or more receptacles, absorbent materials, spacing structures, thermal insulation, radiation shielding, and devices for cooling or absorbing mechanical shocks. The vehicle, tie-down system, and auxiliary equipment may be designated as part of the packaging. [10 CFR 71.4]

Physical Interface - The boundary at which physical systems interact, as in a necessary fit between architectures.

Physical System - The Nuclear Waste Management System (NWMS) consisting of the composite of the sites, and all facilities, systems, equipment, materials, information, activities, and the personnel required to perform those activities necessary to manage waste disposal.

Prime Mover - The vehicle providing motive power to the transporter.

Producer - Any generator of high-level radioactive waste resulting from atomic energy activities.

Purchaser - Any person, other than a Federal agency, who is licensed by the Nuclear Regulatory Commission to use a utilization or production facility under the authority of sections 103 or 104 of the Atomic Energy Act of 1954 (42 USC 2133, 2134) or who has title to spent nuclear fuel or high level radioactive waste and who has executed a contract with DOE or any contractual instrument. Purchaser includes DOE owned spent nuclear fuel from commercial industry and civilian development programs. [Based on 10 CFR 961.3]

Radioactive-Waste Facility - A facility subject to the licensing and related regulatory authority of the NRC pursuant to sections 202(3) and 202(4) of the Energy Reorganization Act of 1974 (88 Stat. 1244). [10 CFR 960.2]

Repository - Any system licensed by the Commission that is intended to be used for, or may be used for, the permanent deep geologic disposal of high-level radioactive waste and spent nuclear fuel, whether or not such system is designed to permit the recovery, for a limited period during initial operation, of any materials placed in such system. Such term includes both surface and subsurface areas at which high-level radioactive waste and spent nuclear fuel handling activities are conducted. [NWSA Sect. 2(18)]

Requirement - A qualitative or quantitative statement of how well a function must be performed. Requirements may be of three types: Performance Requirements, Constraints, and Interface Requirements.

Requirements Allocation - The further decomposition of system level requirements until a level is reached at which a specific hardware item or software routine can fulfill the needed functional/performance requirements. [DSMC 6.4]

Resource - The people, material, or funds available to support the satisfaction of a function.

Shipment - The movement of the properly packaged cask from the generating facility to the receiving site and all associated regulatory activities.

Shipper* - The person (or his or her agent) who tenders a shipment for transportation. The term includes persons who prepare packages for shipment, and offer packages to a carrier for transportation by signature on the shipping papers. [DOE Order 1540.1, Section 5, q]

Shipping Cask - A container for shipping spent nuclear fuel and/or high-level radioactive waste which meets all applicable regulatory requirements.

Spent Nuclear Fuel - (SNF) - Fuel that has been withdrawn from a nuclear reactor following irradiation, the constituent elements of which have not been separated by reprocessing. [NWPA Sect. 2(23); 10 CFR 961.11, I.18]

System - The geologic setting at the site, the waste package, and the repository, all acting together to contain and isolate the waste. [10 CFR 960.2]

System Performance - The complete behavior of a repository system in response to the conditions, processes, and events that may affect it. [10 CFR 960.2]

Systems Engineering - The management function which controls the total system development effort for the purpose of achieving an optimum balance of all system elements. It is a process which transforms an operational need into a description of system parameters and integrates those parameters to optimize the overall system effectiveness. [DSMC 1.3]. Systems engineering is a sequence of activities and decisions that transforms an identified mission need into a description of system performance parameters and a preferred system configuration [DOE Order 4700.1]

* DOE/OCRWM is the Shipper for all loaded and unloaded casks between Purchaser/Producer sites and NWMS facilities.

Systems Engineering Process - An iterative process applied throughout the acquisition life cycle. The process itself leads to a well defined, completely documented, and optimally balanced system. It does not produce the actual system itself, but rather, it produces the complete set of documentation, tailored to the needs of a specific program, which fully describes the system to be developed and produced. [DSMC 5.1]

Transporter - A cargo-carrying vehicle such as ... semi-trailer, ... or rail car used for the transportation of cargo by any mode. Each cargo-carrying body (trailer, rail car, barge) is a separate transport vehicle. [49 CFR 171.8]

Waste Form - The radioactive waste materials and any encapsulating or stabilizing matrix. [10 CFR 60.2, 10 CFR 960.2]

- The materials comprising the radioactive components of waste and any encapsulating or stabilizing matrix. [40 CFR 191.12(c)]

Waste Transportation System - The waste transportation system will consist of (1) the cask system, which includes transportation casks, vehicular conveyances, tie-downs for securing the casks to transport vehicles, ancillary equipment, and associated handling equipment designed for use in the waste-management system; (2) the transportation support system, which may include a control center, maintenance facilities, and the services and equipment required to support waste transportation; and (3) operating procedures.

APPENDIX B

BIBLIOGRAPHY

1. **ANSI/ASME NQA-1-1986, Quality Assurance Program Requirements for Nuclear facilities. [NQA-1]**
2. **10 CFR 20 (Code of Federal Regulations), Title 10, "Energy", Part 20, "Standards for Protection Against Radiation," U.S. Government Printing Office, Washington, D.C. [10 CFR 20]**
3. **10 CFR 21 (Code of Federal Regulations), Title 10, "Energy," Part 21, "Reporting of Defects and Noncompliance," U.S. Government Printing Office, Washington, D.C. [10 CFR 21]**
4. **10 CFR 50 (Code of Federal Regulations), Title 10, "Energy", Part 50, Appendix B, "Quality Assurance Criteria for Nuclear Power Plants and Fuel Reprocessing Plants," U.S. Government Printing Office, Washington, D.C. [10 CFR 50, Appendix B]**
5. **10 CFR 71 (Code of Federal Regulations), Title 10, "Energy," Part 71, "Packaging and Transportation of Radioactive Material," U.S. Government Printing Office, Washington, D.C. [10 CFR 71]**
6. **10 CFR 73 (Code of Federal Regulations), Title 10, "Energy," Part 73, "Physical Protection of Plants and Materials," U.S. Government Printing Office, Washington, D.C. [10 CFR 73]**
7. **10 CFR 74 (Code of Federal Regulations), Title 10, "Energy," Part 74, "Material Control and Accounting of Special Nuclear Material," U.S. Government Printing Office, Washington, D.C. [10 CFR 74]**
8. **10 CFR 961 (Code of Federal Regulations), Title 10, "Energy," Part 961, "Standard Contract for Disposal of Spent Nuclear Fuel and/or High-Level Radioactive Waste," U.S. Government Printing Office, Washington, D.C. [10 CFR 961]**
9. **49 CFR 171 (Code of Federal Regulations), Title 49, "Transportation," Part 171, "General Information, Regulations, and Definitions," U.S. Government Printing Office, Washington, D.C. [49 CFR 171]**
10. **49 CFR 172 (Code of Federal Regulations), Title 49, "Transportation," Part 172, "Hazardous Materials Tables and Hazardous Materials Communications Regulations," U.S. Government Printing Office, Washington, D.C. [49 CFR 172]**

11. 49 CFR 173 (Code of Federal Regulations), Title 49, "Transportation," Part 173, "Shippers - General Requirements for Shipments and Packagings," U.S. Government Printing Office, Washington, D.C. [49 CFR 173]
12. 49 CFR 174 (Code of Federal Regulations), Title 49, "Transportation," Part 174, "Carriage by Rail," U.S. Government Printing Office, Washington, D.C. [49 CFR 174]
13. 49 CFR 176 (Code of Federal Regulations), Title 49, "Transportation," Part 176, "Carriage by Vessel," U.S. Government Printing Office, Washington, D.C. [49 CFR 176]
14. 49 CFR 177 (Code of Federal Regulations), Title 49, "Transportation," Part 177, "Carriage by Public Highway," U.S. Government Printing Office, Washington, D.C. [49 CFR 177]
15. 49 CFR 392 (Code of Federal Regulations), Title 49, "Transportation," Part 392, "Driving of Motor Vehicles," U.S. Government Printing Office, Washington, D.C. [49 CFR 392]
16. Defense Systems Management College, "Systems Engineering Management Guide," Technical Management Department, U.S. Government Printing Office, Washington, D.C. [DSMC]
17. DOE (U.S. Department of Energy), "Materials Transportation and Traffic Management," DOE Order 1540.11, Washington, D.C. [DOE ORDER 1540.11]
18. DOE (U.S. Department of Energy), "Project Management System," DOE Order 4700.1, Washington, D.C. [DOE ORDER 4700.1]
19. DOE (U.S. Department of Energy), "Occurrence Reporting and Processing of Operations Information," DOE Order 5000.3A, Washington, D.C. [DOE ORDER 5000.3A]
20. DOE (U.S. Department of Energy), "Safety Requirements for the Packaging and Transportation of Hazardous Materials, Hazardous Substances, and Hazardous Wastes," DOE Order 5480.3, Washington, D.C. [DOE ORDER 5480.3]
21. DOE (U.S. Department of Energy), "Radiation Protection for Occupational Workers," DOE Order 5480.11, Washington, D.C. [DOE ORDER 5480.11]
22. DOE (U.S. Department of Energy), 1989. "General Design Criteria," DOE Order 6430.1A, Washington, D.C. [DOE Order 6430.1A]

23. DOE (U.S. Department of Energy), 1985. Mission Plan for the Civilian Radioactive Waste Management Program, Overview and Current Program Plans, DOE/RW-0005, Volume I, Washington, D.C. [Mission Plan]
24. DOE (U.S. Department of Energy), 1987. OCRWM Mission Plan Amendment, DOE/RW-0128, Washington, D.C. [Mission Plan Amendment - June 1987]
25. DOE (U.S. Department of Energy), 1988. Draft 1988 Mission Plan Amendment, DOE/RW-0187, Washington, D.C. [Draft 1988 Mission Plan Amendment - June 1988]
26. DOE (U.S. Department of Energy), 1991. Draft 1991 Mission Plan Amendment, DOE/RW-0316P, Washington, D.C. [Draft 1991 Mission Plan Amendment - September 1991]
27. DOE (U.S. Department of Energy), 1986. Action Memo, "Establishing Policy for Shipping Defense High-Level Waste to a Civilian Radioactive Waste Repository," from J.L. Meinhardt, DOE - DP to Assistant Secretary for DP, DP-1 and Director, OCRWM, RW-1, dated June 17, 1986. [MOA between DP and RW]
28. DOE (U.S. Department of Energy), 1989. The DOE Position on the MRS Facility, DOE/RW-0239, Washington, D.C. [DOE/RW-0239]
29. DOE (U.S. Department of Energy), 1989. Report to Congress on Reassessment of the Civilian Radioactive Waste Management Program, DOE/RW-0247, Washington, D.C. [DOE/RW-0247]
30. DOE (U.S. Department of Energy), 1987. Characteristics of Spent-Fuel, High-Level Waste, and Other Radioactive Wastes Which May Require Long-Term Isolation, DOE/RW-0184, Washington, D.C. [DOE/RW-0184]
31. DOE (U.S. Department of Energy), 1987. Quality Assurance Requirements Document, DOE/RW-0214, Washington, D.C. [DOE/RW-0214]
32. "Management Systems Improvement Strategy," (MSIS), Memorandum dated August 10, 1990, from John W. Bartlett
33. Meta Software Corporation, 1989, Design IDEF, Version 1.5, Cambridge, MA
34. NWPA (Nuclear Waste Policy Act), 1983. "Nuclear Waste Policy Act of 1982," Public Law 97-425, 42 USC 10101 -10226, Washington, D.C. This Act includes Amendments PL 100-203 (Dec 22, 1987) and PL 100-507 (Oct 18, 1988) [NWPA]
35. OSHA (Occupational Safety and Health Act), 29 USC 651 [29 USC 651 et.seq.]

36. Oak Ridge National Laboratory, 1989. Transportation Functions of the Federal Waste Management Systems, ORNL/TM-11232.
37. Physical System Requirements - Overall System, Draft Document, June 20, 1991 [Overall System Document]
38. Presidential Memo, 1985. Memo, "Disposal of Defense Waste in a Commercial Repository", from the President, Ronald Reagan, to the Secretary of Energy, John Herrington, dated April 30, 1985. [Presidential Memo]
39. Technical Document Management Plan, "Physical System Requirements/Functional Analysis Management Plan," 1991

APPENDIX C

DECISION DOCUMENTATION

Specifications of many performance and interface requirements and the selection of particular architectural concepts are the results of DOE decisions. As additional decisions are made and documented, they will be included in the technical baseline and documented in this section.

1. All shipments from the MRS facility to the repository would be made exclusively by rail in dedicated trains, which would minimize the number of shipments to the repository.

[DOE/RW-0239]

From the MRS facility, the spent fuel will be shipped in dedicated trains to the repository.

[DOE/RW-0316P, page 101]

2. High-level waste will be shipped by rail directly from the sites where it is stored to the repository.

[DOE/RW-0316P, page 101]

3. As directed by the Congress, we will use private industry to the fullest extent possible in each aspect of transportation, including the development and procurement of shipping casks, the transportation support system, and associated services.

[DOE/RW-0316P, page 103]

4. The transportation support system will consist of a cask-maintenance facility, which may be constructed at the site of the MRS facility, ...

[DOE/RW-0316P, page 111]

APPENDIX D

ACRONYMS

AE	Accessible Environment
ALARA	As Low as Reasonably Achievable
CMF	Cask Maintenance Facility
CoC	Certificate of Compliance
CFR	Code of Federal Regulations
CHLW	Commercial High-Level Radioactive Waste
CMF	Cask Maintenance Facility
CRWM	Commercial Radioactive Waste Management
DHLW	Defense High-Level Radioactive Waste
DCS	Delivery Commitment Schedule
DOE	Department of Energy
DOT	Department of Transportation
DP	Office of Defense Programs, Department of Energy
DSMC	Defense Systems Management College
DWPF	Defense Waste Processing Facility
EOC	Emergency Operations Center
EPA	Environmental Protection Agency
FDS	Final Delivery Schedule
FEMA	Federal Emergency Management Agency
f.o.b.	Freight on Board
F-R-A	Functions-Requirements-Architecture
GVWt	Gross Vehicle Weight
HLW	High-Level Radioactive Waste
IAEA	International Atomic Energy Agency
MSIS	Management System Improvement Strategy
MOA	Memorandum of Agreement
MRS	Monitored Retrievable Storage
MTHM	Metric Tons of Heavy Metal
MTU	Metric Tons of Uranium
MWd	Megawatt Days
NEPA	National Environmental Policy Act
NRC	Nuclear Regulatory Commission
NWMS	Nuclear Waste Management System
NWPA	Nuclear Waste Policy Act
OCC	Operations Control Center
OCRWM	Office of Civilian Radioactive Waste Management
PP	Purchaser and/or Producer
PSO	Program Secretarial Officers
QA	Quality Assurance
RW	Office of Civilian Radioactive Waste Management
SNF	Spent Nuclear Fuel
TBD	To Be Determined
TRU	Transuranic
USC	United States Code
WVDP	West Valley Demonstration Project

APPENDIX E

TRANSPORT WASTE INTERFACES

INTERFACE CONTROL #	FROM	TO	OUTPUT/INPUT TITLE	OUTPUT/INPUT ID#
1.1/1.2	Accept Waste	Transport Waste	Loaded SNF Casks/Transporters Loaded CHLW Casks/Transporters Loaded DHLW Casks/Transporters	1.101/1.211 1.102/1.212 1.103/1.213
1.1/1.2.1	Accept Waste	Accept Loaded Cask for Transportation	Authorization to Ship	Control
1.2/1.1	Transport Waste	Accept Waste	Unloaded Casks/Transporters	1.204/1.114
1.2/1.3	Transport Waste	Store Waste	Loaded SNF Casks/Transporters Unloaded SNF Casks/Transporters	1.201/1.311 1.204/1.312
1.2/1.4	Transport Waste	Dispose of Waste	Loaded SNF Casks/Transporters Loaded CHLW Casks/Transporters Loaded DHLW Casks/Transporters	1.201/1.411 1.202/1.412 1.203/1.413
1.2/AE	Transport Waste	Accessible Environment	Federally-Limited Radiation Exposure Federally-Limited Release of Radio-nuclides	1.205 1.206

TRANSPORT WASTE INTERFACES (con't)

INTERFACE CONTROL #	FROM	TO	OUTPUT/INPUT TITLE	OUTPUT/INPUT ID#
1.3/1.2	Store Waste	Transport Waste	Loaded SNF Casks/Transporters Unloaded SNF Casks/Transporters	1.3O1/1.2I2 1.3O2/1.2I4
1.4/1.2	Dispose of Waste	Transport Waste	Unloaded Casks/Transporters	1.4O1/1.2I4
S/1.2.2	States, Tribes, DOT, NRC	Ship Waste	Routes and Permits	Control
PP/1.1/1.3/ 1.2.1	Purchaser/Producer/ Accept Waste/ Store Waste	Accept Loaded Cask for Transportation	Information	1.2.1I4

APPENDIX F1

WASTE ACCEPTANCE SCHEDULE

Year	<u>Annual Waste Acceptance Rate</u>			<u>Annual Waste Transportation Rate</u>		
	SNF	CHLW	DHLW	Accept: SNF	Accept: CHLW	Accept: DHLW
1998				Score: CHLW	Score: CHLW	Score: CHLW
1999						
2000						
2001						
2002						
2003						
2004						
2005						
2006						
2007						
2008						
2009						
2010						
.						
.						
.						
						TBD

APPENDIX F2

SNF CHARACTERISTICS FOR DESIGN OF TRANSPORTATION SYSTEM TO/FROM MRS

Year	SNF Transmitted to MRS			SNF Inventory at MRS			SNF Transmitted From MRS		
	Age	Burnup	Qty.	Age	Burnup	Qty.	Age	Burnup	Qty.
1998									
1999									
2000									
2001									
2002									
2003									
2004									
2005									
2006									
2007									
2008									
2009									
2010									
...									

TBD

APPENDIX F3

SNF TRANSPORTATION RATES TO/FROM MRS BY MODE

Year	ENT TO MRS		ENT FROM MRS
	Truck	RAI	
1998			
1999			
2000			
2001			
2002			
2003			
2004			
2005			
2006			
2007			
2008			
2009			
2010			

TBD

APPENDIX G

INDENTURED LIST OF TRANSPORT WASTE FUNCTIONS

(1. Manage Waste Disposal)

1.2 Transport Waste

1.2.1 Accept Loaded Cask for Transportation

1.2.1.1 Contain Waste for Transportation

1.2.1.2 Observe Transport Preparations

1.2.1.3 Verify Loaded Cask Contents

1.2.1.4 Transfer Responsibility for Shipment

1.2.2 Ship Waste

1.2.2.1 Prepare for Shipment

1.2.2.1.1 Inspect Vehicles

1.2.2.1.2 Prepare Shipping Documents

1.2.2.1.3 Brief Transportation Crew

1.2.2.2 Move Shipment

1.2.2.2.1 Transport Loaded Cask

1.2.2.2.2 Acquire In-Transit Permits

1.2.2.2.3 Perform In-Transit Repairs

1.2.2.2.4 Perform Security Functions

1.2.2.2.5 Perform Intermodal Transfers

1.2.2.3 Deliver Shipment

1.2.2.3.1 Position Loaded Cask/Transporter

1.2.2.3.2 Debrief Transportation Crew

1.2.2.3.3 Transfer Shipping Documents

1.2.2.4 Manage Traffic

1.2.2.4.1 Prepare/Coordinate Traffic Flow Schedules

1.2.2.4.2 Issue Transport Notifications

1.2.2.4.3 Monitor Traffic Flow Status

1.2.2.4.4 Coordinate Traffic Communications

1.2.2.4.5 Issue Dispatch Orders

1.2.2.4.6 Obtain Special Transport Permits

1.2.2.4.7 Support Emergency Response Communications

1.2.2.4.8 Collect/File Transportation Records

1.2.3 Support Waste Transportation Operations

1.2.3.1 Plan Transport Operations

1.2.3.1.1 Plan Campaigns and Transportation System Operations

1.2.3.1.2 Prepare Long-Range Plans

1.2.3.2 Conduct Regulatory Compliance Activities

1.2.3.2.1 Monitor Compliance with Applicable Regulatory Requirements

1.2.3.2.2 Monitor Changes in Regulatory Requirements and Standards

1.2.3.2.3 Notify Other Functions of Changes in Requirements

- 1.2.3.2.4 Monitor NRC Certificates of Compliance / other Permits and Licenses
- 1.2.3.3 Manage Transportation System
 - 1.2.3.3.1 Protect Environment, Facilities, and Workers
 - 1.2.3.3.1.1 Protect Environment
 - 1.2.3.3.1.2 Provide Security
 - 1.2.3.3.1.3 Protect Workers
 - 1.2.3.3.2 Administer General Support Services
 - 1.2.3.3.2.1 Manage Information
 - 1.2.3.3.2.2 Conduct Engineering Support
 - 1.2.3.3.2.3 Provide for Human Resources
 - 1.2.3.3.2.4 Train Workforce
 - 1.2.3.3.2.5 Procure/Contract Goods and Services
 - 1.2.3.3.2.6 Inform Public
 - 1.2.3.3.2.7 Conduct Financial and Accounting Services
 - 1.2.3.3.3 Manage Transportation System Waste
 - 1.2.3.3.4 Maintain Operating Facilities
 - 1.2.3.3.5 Administer Quality Assurance
 - 1.2.3.3.6 Direct Operations of Transportation System
- 1.2.3.4 Maintain Cask System
 - 1.2.3.4.1 Maintain Casks
 - 1.2.3.4.2 Service and Maintain Vehicles
 - 1.2.3.4.3 Service and Maintain Ancillary Equipment

1.2.3.5 Conduct Field Operations

1.2.3.5.1 Support Waste Acceptance

1.2.3.5.2 Support MRS/Repository

1.2.3.5.3 Support In-Transit Operations

1.2.3.5.4 Support In-Transit Emergency Responses

1.2.3.6 Move Unloaded Casks

1.2.3.6.1 Transport Unloaded Casks

1.2.3.6.2 Acquire In-Transit Permits

1.2.3.6.3 Perform In-Transit Repairs

1.2.3.6.4 Perform Intermodal Transfers

1.2.3.6.5 Deliver Unloaded Casks

1.2.3.6.5.1 Debrief Transportation Crew

1.2.3.6.5.2 Position Unloaded Cask/Transporter

1.2.3.6.5.3 Transfer Shipping Documents

1.2.3.6.6 Manage Traffic

1.2.3.6.6.1 Prepare/Coordinate Traffic Flow Schedules

1.2.3.6.6.2 Monitor Traffic Flow Status

1.2.3.6.6.3 Issue Dispatch Orders

1.2.3.6.6.4 Obtain Special Transport Permits

1.2.3.6.6.5 Support Emergency Response Communications

1.2.3.6.6.6 Collect/File Transportation Records

1.2.3.7 Manage Inventories

- 1.2.3.7.1 Manage Unloaded Casks**
- 1.2.3.7.2 Manage Vehicles**
- 1.2.3.7.3 Manage Ancillary Equipment**
- 1.2.3.7.4 Manage Spare Parts and Consumables**

The following number is for OCRWM Records Management purposes only and should not be used when ordering this publication.

Accession No: HQO•920413•0001

UNITED STATES
DEPARTMENT OF ENERGY

RW-30
WASHINGTON, DC 20585

OFFICIAL BUSINESS
PENALTY FOR PRIVATE USE, \$300