

Safety Analysis Report for Packaging Safkeg-LS Design No. 3979A Package Docket No. 07109337



Application for Approval by the NRC Applicant: Croft Associates Limited

Number	CTR 2008/10
Issue	10
File Ref	CTR2008-10-Rev10-v1-Safety Analysis Report LS 3979A - redacted.docx
Date	19/03/2026

0 Contents

0	Content Management.....	0-6
0.1	Document verification and revision status.....	0-6
0.2	Revision history.....	0-6
0.3	SARP Status and Contents.....	0-7
0.4	PAGE AND SUPPORTING DOCUMENT REVISION STATUS.....	0-7
0.5	Appendix.....	0-12
1	General Information.....	1-1
1.1	Introduction.....	1-1
1.2	Package Description [71.33].....	1-2
1.3	Appendix.....	1-30
2	Structural Evaluation.....	2-1
2.1	Description of Structural Design.....	2-3
2.2	Materials.....	2-16
2.3	Fabrication and Examination.....	2-24
2.4	General Requirements for All Packages [71.43].....	2-25
2.5	Lifting and Tie-Down Standards for All Packages.....	2-26
2.6	Normal Conditions of Transport.....	2-26
2.7	Hypothetical Accident Conditions [71.73].....	2-42
2.8	Accident Conditions for Air Transport of Plutonium [71.74].....	2-56
2.9	Accident Conditions for Fissile Material Packages for Air Transport [1.55(f)].....	2-56
2.10	Special Form [71.75].....	2-56
2.11	Fuel Rods.....	2-56
2.12	Appendix.....	2-56
3	Thermal Evaluation.....	3-1
3.1	Description of Thermal Design.....	3-1
3.2	Material Properties and Component Specifications.....	3-6
3.3	Thermal Evaluation under Normal Conditions of Transport.....	3-10
3.4	Thermal Evaluation under Hypothetical Accident Conditions.....	3-17
3.5	Appendix.....	3-26
4	Containment Evaluation.....	4-1
4.1	Description of the Containment System [71.33 (a)(4)].....	4-1
4.2	Containment Under Normal Condition of Transport (NCT) [71.51 (a)(1)].....	4-4
4.3	Containment Under Hypothetical Conditions (HAC) [71.51 (a)(2)].....	4-5
4.4	Leakage Rate Test for Type B Packages.....	4-6
4.5	Appendix.....	4-7
5	Shielding Evaluation.....	5-1
5.1	Description of Shielding Design.....	5-2
5.2	Summary Table of Maximum Radiation Levels.....	5-5
5.3	Source Specification [71.33 (b)(1)].....	5-6

5.4	Shielding Model.....	5-7
5.5	Shielding Evaluation.....	5-7
5.6	Appendix.....	5-26
6	Criticality Evaluation.....	6-1
6.1	Description of Criticality Design.....	6-1
6.2	Fissile Material Contents.....	6-1
6.3	General Consideration.....	6-2
6.4	Single Package Evaluation.....	6-2
6.5	Evaluation of Package Arrays under Normal Conditions of Transport.....	6-2
6.6	Package Array Under Hypothetical Conditions.....	6-2
6.7	Fissile Material Packages for Air Transport.....	6-2
6.8	Benchmark Evaluations.....	6-2
6.9	Appendix.....	6-2
7	Package Operations.....	7-1
7.1	Package loading.....	7-1
7.2	Package Unloading.....	7-4
7.3	Preparation of Empty Packages for Transport.....	7-5
7.4	Other Operations.....	7-6
7.5	Appendix.....	7-6
8	Acceptance Test & Maintenance Program.....	8-1
8.1	Acceptance Tests [71.85].....	8-2
8.2	Maintenance Program.....	8-5
8.3	Appendix.....	8-10

Tables

Table 1-1	Maximum mass of the radionuclides.....	1-11
Table 1-2	Contents Types.....	1-13
Table 1-3	CT-1 – Solid in heavy tungsten insert (LS-12x65-Tu Design No 3984).....	1-13
Table 1-4	CT-2 – Solid in light tungsten insert (LS-31x73-Tu Design No 3983).....	1-15
Table 1-5	CT-3 – Solid in steel insert (LS-50x103-SS Design No 3986).....	1-15
Table 1-6	CT-4 - Liquid in light tungsten insert (LS-31x73-Tu Design No 3983).....	1-16
Table 1-7	CT-5 – Liquid in steel insert (LS-50x103-SS Design No 3986).....	1-16
Table 1-8	CT-6 – Gas in light tungsten insert (LS-31x73-Tu Design No 3983).....	1-17
Table 1-9	CT-7 – Fissile solid in Normal Form in steel insert (LS-50x103-SS Design No 3986) 1-17	
Table 1-10	CT-8 – Fissile solid in Special Form in steel insert (LS-50x103-SS Design No 3986).....	1-18
Table 1-11	CT-1 – Solid in heavy tungsten insert (LS-12x65-Tu) #3984 – Activity Limits.....	1-19
Table 1-12	CT-2 – Solid in light tungsten insert (LS-31x73-Tu) #3983 – Activity Limits.....	1-22
Table 1-13	CT-3 – Solid in steel insert (LS-50x103-SS) #3986 – Activity Limits.....	1-25
Table 1-14	CT-4 - Liquid in light tungsten insert (LS-31x73-Tu) – Activity Limits.....	1-26
Table 1-15	CT-5 – Liquid in steel insert (LS-50x103-SS) – Activity Limits.....	1-26
Table 1-16	CT-6 – Gas in light tungsten insert (LS-31x73-Tu) #3983 – Activity Limits.....	1-27

Table 1-17 CT-7 – Fissile solid in Normal Form in steel insert (LS-50x103-SS) #3986 – Activity Limits	1-27
Table 1-18 CT-8 – Fissile solid in Special Form in steel insert (LS-50x103-SS) #3986 – Activity Limits	1-28
Table 2-1 Load Combinations for NCT	2-5
Table 2-2 Load Combinations for HAC	2-6
Table 2-3 Containment System Allowable Design Criteria	2-8
Table 2-4 Containment vessel shell buckling geometric parameters	2-9
Table 2-5 Buckling reduction factors and theoretical buckling stresses	2-9
Table 2-6 Shell allowable buckling stresses	2-9
Table 2-7 Weights of SAFKEG 3979A	2-11
Table 2-8 Applicable Codes and Standards for the Manufacture of the 3979A Package	2-13
Table 2-9 Alternative Requirements to the ASME Code Requirements	2-14
Table 2-10 Packaging Material Specifications	2-16
Table 2-11 Material Properties for Grade 304L Stainless Steel	2-20
Table 2-12 Mechanical Properties of SA-320/A320 Grade L43 Bolting Steel	2-21
Table 2-13 Mechanical Properties and Temperature for Grade L7 (From a comparison with L43 provided in CTR 2025/01 [2.12.2])	2-22
Table 2-14 Mechanical Properties of Lead Shielding	2-22
Table 2-15 Average compressive Modulus of Elasticity and Compressive Strength at 10% Relative Deformation for Cork at each Test Temperature	2-23
Table 2-16 Summary of Material Interactions	2-23
Table 2-17 Containment Vessel Stress Summary under Heat Conditions	2-28
Table 2-18 Containment Vessel Bolts Stress Analysis under Heat Conditions	2-28
Table 2-19 Containment Vessel Buckling Calculations Under Heat Conditions	2-28
Table 2-20 Containment Vessel Fatigue Evaluation under Heat Conditions	2-28
Table 2-21 Containment Vessel Stress Summary under Cold Conditions	2-30
Table 2-22 Containment Vessel Bolts Stress Analysis under Cold Conditions	2-30
Table 2-23 Containment Vessel Buckling Calculations Under Cold Conditions	2-30
Table 2-24 Containment Vessel Fatigue Evaluation under Cold Conditions	2-30
Table 2-25 Containment Vessel Stress Summary for Changes to External Pressure	2-31
Table 2-26 Containment Vessel Bolts Stress Analysis for Changes to External Pressure	2-32
Table 2-27 Containment Vessel Stress Summary for Vibration Loads	2-34
Table 2-28 Containment Vessel Bolts Stress Analysis under Vibration Load Conditions	2-35
Table 2-29 Containment Vessel Buckling Calculations under Vibration Load Conditions	2-35
Table 2-30 Acceleration Data Recorded during Drop Tests	2-38
Table 2-31 Acceleration values applied to the FEA Analysis	2-38
Table 2-32 NCT Free Drop Stress Summary	2-39
Table 2-33 Containment Vessel Closure Bolts NCT Free Drop Stress Summary	2-40
Table 2-34 NCT Free Drop Buckling Evaluation Summary	2-41
Table 2-35 End Drop Containment Vessel Stress Summary	2-46
Table 2-36 End Drop Containment Vessel Bolt Stress Summary	2-46
Table 2-37 End Drop Containment Vessel Buckling Evaluation	2-46
Table 2-38 Side Drop Containment Vessel Stress Summary	2-48
Table 2-39 Side Drop Containment Vessel Bolt Stress Summary	2-48
Table 2-40 Side Drop Containment Vessel Buckling Evaluation	2-49
Table 2-41 Corner Drop Containment Vessel Stress Summary	2-50
Table 2-42 Corner Drop Containment Vessel Bolt Stress Summary	2-51
Table 2-43 Corner Drop Containment Vessel Buckling Evaluation	2-51
Table 2-44 Containment Vessel Stress Summary for Immersion	2-55
Table 2-45 Total Bolt Force After Analysis	2-56

Table 3-1 Calculated Maximum Containment Vessel Temperature under NCT and HAC	3-4
Table 3-2 Summary of Calculated Package Temperatures with 10 W Internal Heat Load under NCT (Ambient 38°C, with and without insolation)	3-4
Table 3-3 Summary of Package Temperatures for HAC Thermal Test (Ambient 38°C, with and without insolation)	3-5
Table 3-4 Summary Table of Maximum Pressures in the Containment Vessel.....	3-5
Table 3-5 Thermal Properties of Packaging Materials	3-6
Table 3-6 Emissivities used in the Thermal Model	3-8
Table 4-1 Safkeg-LS - Dose rate at the containment seal - based on Ir-192	4-3
Table 5-1 Summary Table of Maximum Radiation Levels Under Normal Conditions of Transport Under Exclusive Use.....	5-5
Table 5-2 Summary Table of External Surface Radiation Levels and Maximum O-ring Dose Rate - Monte Carlo calculations for reference case (Ir-192)	5-8
Table 5-3 Summary Table of External Radiation Levels at 1m from the Surface - Monte Carlo calculations for reference case (Ir-192)	5-9
Table 5-4 Summary Table of External Radiation Levels - MicroShield calculations	5-10
Table 5-5 NCT Activity Limits based on a contact dose rate of 2mSv/h and 10mSv/h respectively	5-14
Table 5-6 NCT Activity Limits based on a dose rate of 0.1mSv/h at 1m from the surface	5-16
Table 5-7 HAC Activity limits based on a dose rate of 10mSv/h at 1m from the surface.....	5-19
Table 5-8 Exclusive-Use, 0.1mSv/h 2m from package surface.....	5-21
Table 5-9 Geometry and dimensions employed in Table 5-8.....	5-25
Table 8-1 Package Maintenance Summary.....	8-9

Figures

Figure 1-1 Safkeg-LS 3979A package – Section View and Nomenclature	1-4
Figure 1-2 Safkeg-LS 3979A package – Isometric view	1-5
Figure 1-3 3980 CV – Top and Section View and Nomenclature.....	1-6
Figure 1-4 3980 CV – Isometric View	1-7
Figure 1-5 Containment boundary of the Safkeg-LS 3979A package	1-8
Figure 1-6 Gamma shielding present in the Safkeg-LS 3979A package.....	1-9
Figure 1-7 Shielding insert LS-12x65-Tu – Design # 3984	1-12
Figure 1-8 Shielding insert LS-31x73-Tu – Design # 3983	1-12
Figure 1-9 Shielding insert LS-50x103-SS – Design # 3986.....	1-12
Figure 2-1 Stress Evaluation Locations	2-16
Figure 2-2 NCT Free Drop Impact Orientations.....	2-38
Figure 2-3 HAC Free Drop Impact Orientations.....	2-44
Figure 2-4 Puncture Tests Impact Orientations	2-53
Figure 3-1 Thermal Design Properties	3-3
Figure 3-2 Thermal Conductivity of Cork.....	3-8
Figure 3-3 Comparison of Measured and Predicted Temperatures in the Steady-State Heating Test.....	3-12
Figure 3-4 Predicted temperature on the Outside of the Keg During Normal Transport with Insolation	3-14
Figure 3-5 Predicted Temperature at the Containment vessel lid Seal During Normal Conditions of Transport with Insolation	3-15
Figure 3-6 Predicted Temperature Profile under Normal Conditions of Transport With Solar Insolation	3-16
Figure 3-7 Furnace Temperature and External Surface Temperature in the Fire Test.....	3-19

Figure 3-8 Comparison of Predicted and Measured Temperature of the Containment Vessel Lid
in the Fire Test..... 3-20

Figure 3-9 Predicted Temperature of the Outside of the Keg during the Fire Test..... 3-22

Figure 3-10 Predicted Temperature Profile at the end of the Heating Phase of the Fire Accident
..... 3-23

Figure 3-11 Predicted Temperature of the Containment Vessel during the Fire Test 3-24

Figure 4-1 Package Containment Boundary..... 4-2

Figure 4-2 Leak Test Seal Arrangement..... 4-4

Figure 5-1 Gamma shielding present in the 3979A package 5-3

Figure 5-2 Shielding insert LS-12x65-Tu – Design # 3984 5-4

Figure 5-3 Shielding insert LS-31x73-Tu – Design # 3983 5-4

Figure 5-4 Shielding insert LS-50x103-SS – Design # 3986..... 5-4

Figure 5-5 Not used 5-7



Figure 5-6 Source positions within the 3983 insert 5-12

Figure 5-7 : Section view of the model through the z-axis showing the location of the contact
volume tallies on the outside of the Keg coincident with source locations 5-13

Content Management

0.1 Document verification and revision status

This section

Document Verification			
Title	Safety Analysis Report for Packaging Safkeg-LS Design No. 3979A Package Docket No. 07109337		
Project Number			
Document Reference	CTR 2008/10		
Revision	9	Date: 26 August 2025	
Basis and details of change			
Additional nuclides added for insert #3983. The option for liquid contents removed.			
	Compiled	Checked	Approved
Name	A L Ferguson	G Longman	M B Johnson
Signature			
Revision	10	Date: 19 March 2026	
Basis and details of change			
Changes identified in CTR 2025/04 Issue B: <ul style="list-style-type: none"> 0.25A2 impurity notes added Drawing 9012 updated to depict missing weld representation 			
	Compiled	Checked	Approved
Name	A L Ferguson	G Longman	M B Johnson pp
Signature			

0.2 Revision history

The revision history of this document is presented in CTR 2025/04.

0.3 SARP Status and Contents

This Safety Analysis Report for Packaging (SARP) has been prepared by Croft Associates Ltd for the new approval of the SAFKEG-LS Design No. 3979A transport package as a Type B(U) design.

This section (Section 0.4) defines the document status and lists the contents of the SARP (SARP sections and appended documents included in the SARP).

This SARP is a controlled document under the Croft Associates Ltd Quality Assurance Program approved by the NRC under Approval Number 071-0939.

Revisions are on a document control basis (from Rev. 9 onwards), with revisions indicated by a vertical change bar in the left hand margin.

Reference documents, which are listed in the Appendices to each section, are those available in the general literature and are not provided in the SARP.

Supporting documents are those developed specifically for the SARP and are provided in the section that is most closely associated with the document. These supporting documents are listed in this section, together with their revision status.

Document control for the supporting documents, which have been produced by different organizations at different times with different styles, is established by reference designations and issue status and/or date: there is no significance in the various policies of adding the names of author, checker or approver or whether they are manually or electronically signed.

0.4 PAGE AND SUPPORTING DOCUMENT REVISION STATUS

Page/Document Reference	Issue Status	Title/ <i>Comments</i>
Section 0 – Page and Supporting Document Revision Status		
Page 0-1 to 0-12	Rev 10	Section 0. <i>Drawing Issue references updated (missing weld observation)</i>
Documents in Section 0 Appendix		
CTR 2025/04	Issue B	SARP LS 3979A Revision History (Package Docket No. 07109337)
Section 1 - GENERAL INFORMATION		
Page 1-1 to 1-35	Rev 10	Section1. <i>Section 1.2.2.3 reference to impurity assessment added.</i>
Documents in Section 1.3 Appendix		
Documents in Section 1.3.2 Calculation Model Drawings		

Page/Document Reference	Issue Status	Title/ <i>Comments</i>
0C-6049	Issue A	Safkeg-LS Construction
1C-6097	Issue A	Containment Vessel LS Lid Construction
1C-6099	Issue A	Containment Vessel LS Body Construction
Documents in Section 1.3.3 Licensing Drawings		
1C-6040	Issue K	Cover sheet for Safkeg-LS design no. 3979A (licensing drawing)
0C-6041	Issue E	Safkeg-LS design no. 3979A (licensing drawing)
0C-6042	Issue H	Keg design no. 3979 (licensing drawing)
0C-6043	Issue C	Cork set for Safkeg-LS (licensing drawing)
1C-6044	Issue H	Containment vessel design no. 3980 (licensing drawing)
1C-6045	Issue F	Containment vessel lid (assy a) (licensing drawing)
1C-6046	Issue F	Containment vessel body (licensing drawing)
2C-6171	Issue D	LS-12x65-Tu insert design No. 3984 (licensing drawing)
2C-6172	Issue D	LS-31x73-Tu insert design No. 3983 (licensing drawing)
2C-6175	Issue F	LS-50x103-SS insert design No. 3986 (licensing drawing)
1C-9012	Issue B	Containment vessel design #3980 (assy b) (licensing drawing) Machined lead components
1C-9013	Issue A	Containment vessel lid (assy b) (licensing drawing) Machined lead component
1C-9014	Issue A	Containment vessel body (assy b) (licensing drawing) Machined lead component
M1049	Issue A	Drawing 'Change Control Document and Mod Sheet'

Page/Document Reference	Issue Status	Title/ <i>Comments</i>
		This details all the changes since the last approved set of Licensing drawings.
M1058	Issue A	Drawing 'Change Control Document and Mod Sheet': Correction of drawing 1C-9012 to add the lead encasement weld
Documents in Section 1.3.4 Supporting Documents		
PCS 036	Issue E	Package Contents Specification for Safkeg-LS - Package Design No 3979A <i>Rev 9 Updates:</i> <i>New nuclides and shielding calculation limits added for Insert #3983</i> <i>Microshield calculations relating to Insert #3983 replaced with monte carlo calculations.</i>
CTR 2024/08	Issue B	[REDACTED]
CTR 2024/09	Issue A	[REDACTED]
Section 2 - STRUCTURAL EVALUATION		
Page 2-1 to 2-59	Rev 10	Section 2. <i>No change.</i>
Documents in Section 2.12.2, Appendix		
CTR 2009/21	Issue D	Prototype Safkeg-LS 3979A/0002 NCT and HAC Regulatory Test Report
CTR 2009/27	Issue A	Prototype SAFKEG LS 3979A/0002 NCT and HAC Regulatory Test Report
SERCO/TAS/002762/01	Issue 1	Compression Testing of Cork
Vectra, 925-3272/R1	Rev 6	Stress Analysis of Safkeg LS 3979A Containment Vessel

Page/Document Reference	Issue Status	Title/ <i>Comments</i>
CS 2009/08	Issue A	SAFKEG LS 3979A – Maximum Pressure in CV
CS 2010/11	Issue B	Calculation of the Density of the 3977A Package
Vectra, 925-3274/R1	Rev 1	Safkeg LS 3979A – Additional HAC Case
Vectra, 925-3272/M2	15/03/10	Safkeg LS 3979A – Mesh Sensitivity Analysis
CTN 2025/01	Issue A	Comparison Between ASTM A320 Grade L7 and Grade L43 <i>Rev 9 Changes:</i> <i>Document added in Rev 9 to allow an alternative CV lid bolting material.</i>
Section 3 - THERMAL EVALUATION		
Page 3-1 to 3-27	Rev 10	Section 3. <i>Rev 8 Changes:</i> <i>Entire section raised to Rev 8, pages renumbered.</i> <i>Section 3.2.2, page 3-11: 1st paragraph changed to reduce NCT test temperature from 150°C to 130°C</i> <i>Note (second paragraph, added.</i> <i>Section 3.5.2, page 3-30: CTR 2021/22 and CTR 2021/24 added.</i> <i>Rev. 10: no changes.</i>
Documents in Section 3.5.2, Appendix		
SERCO/TAS/5388/001	Issue 2	Thermal Analysis of the Safkeg LS Design
SERCO CJF10302	31 Mar 10	Response to comments on thermal performance of SAFKEG LS raised by NRC assessor
CS 2010/16	Issue A	SAFKEG LS 3979A – Maximum Temperature of CV Inserts
CTR 2021/22	Issue A	3979A O-ring NCT Test Temperature Reduction - SARP Impact

Page/Document Reference	Issue Status	Title/ <i>Comments</i>
		<i>Document added in Rev 8 to justify NCT seal test temperature reduction.</i>
CTR2021/24	Issue A	LS 3979A (3980) O-ring Seal Thermal Tests <i>Document added in Rev 8 to provide test evidence for NCT seal test temperature reduction.</i>
Section 4 - CONTAINMENT		
Page 4-1 to 4-7	Rev 10	Section 4. <i>No changes</i>
Documents in Section 4.5.2, Appendix		
CS 2009/06	Issue A	SAFKEG-LS # 3979A - CV seal leak size for leaktight condition
CS 2009/07	Issue B	SAFKEG-LS 3979A - Gas contents limit for leaktight condition
Section 5 - SHIELDING EVALUATION		
Page 5-1 to 5-26	Rev 10	Section 5. <i>No changes.</i>
Documents in Section 5.5.2, Appendix		
CTR2009/22	Issue B	SAFKEG LS 3979A: Package Activity Limits Based on Shielding
CTR 2015/10	Issue A	Uncertainties Associated with the Proposed Shielding Calculation Method for the SAFKEG-LS 3979A Package
SERCO/TAS/003191/001 (ETR 319)	Issue 1	Monte Carlo Modelling of Safkeg LS Container
Cerberus C.02086- CROFT-PACK-B02-C01- I1 (ETR 566)	Issue 1 (B)	Transport Shielding Assessment for the Croft SAFKEG-LS Package DN 3979A
Section 6 - CRITICALITY EVALUATION		

Page/Document Reference	Issue Status	Title/ <i>Comments</i>
Page 6-1 to 6-2	Rev 10	Section 6. <i>No changes</i>
Documents in Section 6.9, Appendix		
None	-	
Section 7 - OPERATING PROCEDURES		
Page 7-1 to 7-6	Rev 10	Section 7. <i>Reference to ISO 12807 removed</i>
Documents in Section 7.5, Appendix		
None	-	
Section 8- ACCEPTANCE TESTS AND MAINTENANCE PROGRAM		
Page 8-1 to 8-10	Rev 10	Section 8. <i>Rev 8 approved Changes:</i> <i>Entire section raised to Rev 8, pages renumbered.</i> <i>Section 8.1.5.2, page 8-3, 1st, 2nd and 6th paragraphs.</i> <i>NCT O-ring seal test temperature reduced from 150°C to 130°C (130 to 135°C range).</i> <i>Rev.10: Reference to ISO 12807 removed.</i>
Documents in Section 8.3, Appendix		
None	-	

(Croft [External](#) [Technical](#) [Report](#) reference)

0.5 Appendix

0.5.1 Supporting Documents

Document Reference	Issue Status	Title
CTR 2025/04	B	SARP LS 3979A Revision History



		(Package Docket No. 07109337)
--	--	-------------------------------

1 General Information

Contents

1	General Information.....	1-1
1.1	Introduction	1-1
1.2	Package Description [71.33].....	1-2
1.2.1	Packaging.....	1-2
1.2.1.1	General	1-2
1.2.1.2	3979 Keg	1-2
1.2.1.3	3980 CV	1-2
1.2.1.4	Containment Boundary	1-3
1.2.1.5	Gamma Shielding	1-3
1.2.1.6	Energy Absorbing Features.....	1-3
1.2.1.7	Heat Transfer Features	1-4
1.2.1.8	Labelling	1-4
1.2.2	Contents.....	1-10
1.2.2.1	Contents - General.....	1-10
1.2.2.2	Inserts.....	1-10
1.2.2.3	Contents Types.....	1-13
1.2.3	Special Requirements for Plutonium.....	1-29
1.2.4	Operational Features	1-29
1.2.5	Compliance with International Regulations	1-29
1.3	Appendix	1-30
1.3.1	References	1-30
1.3.2	Calculation Model Drawings	1-30
1.3.3	Licensing Drawings.....	1-35
1.3.4	Supporting Documents	1-35

1.1 Introduction

This Safety Analysis Report for Packaging (SARP) has been prepared by Croft Associates Ltd for the new approval of the Safkeg-LS 3979A package as a Type B(U) design.

The Safkeg-LS 3979A package is a general purpose container for the transport of non-fissile nuclides and limited quantities of fissile nuclides as specified under NRC general licenses, under non exclusive and exclusive use. The contents may be in solid or gaseous form. The modes of transport specified are road, rail, sea and air. A detailed list of the nuclides can be found in Section 1.2.2. The contents of the package include some nuclides in excess of 3000 A₂ and therefore the package is classified as Category I as defined in NUREG 1609 [1.1].

The Safkeg-LS 3979A package was designed in 2008 and a prototype package fabricated and tested in 2009. Analysis of the safety of the design has also been carried out: the results of the tests and the analysis are provided in this SARP.

All design, manufacturing and testing has been carried out in accordance with the Croft Quality Assurance program which complies with 10 CFR 71 subpart H [1.2] and is approved by the NRC under Approval Number 0939. This SARP has been prepared in accordance with Regulatory Guide 7.9 [1.3] and demonstrates that the package meets all the applicable requirements in 10 CFR 71 [1.2].

1.2 Package Description [71.33]

1.2.1 Packaging

1.2.1.1 General

The general arrangement of the Safkeg-LS 3979A package is provided in drawing 0C-6041 in Section 1.3.3. The drawing shows the package and details all the nominal dimensions and the major design features.

The Safkeg-LS 3979A package (generally called the package in this SARP) consists of a single resealable containment vessel (generally called the CV in this SARP) Design No. 3980 (stainless steel with encased lead shielding), carried within insulating cork packing in an outer stainless steel keg Design No.3979 (generally called the Keg in this SARP).

Section views of the package and the CV are shown in Figure 1-1, Figure 1-2 and Figure 1-3 to Figure 1-6 respectively. These figures also give the nomenclature used throughout this report.

The maximum weight of the package is 59 kg (130 lbs) excluding the contents. The maximum contents weight is 5.8 kg (12.85 lbs), therefore the gross weight of the package is 64.8 kg (142.85 lbs).

1.2.1.2 3979 Keg

The keg Design No.3979 has a stainless steel outer shell and a stainless steel liner between which insulating cork is fitted. The keg is sealed as it has an O-ring weather seal in its closure, however, there is a fuse plug fitted at the bottom of the keg. This fuse plug contains a low melting point alloy which will vent during the HAC fire test providing pressure relief.

The keg is closed by a flat stainless steel lid which is bolted down with 8 stainless steel studs and nuts against a single O-ring which provides a weather seal to keep rain from entering the keg. The studs are fitted with seal holes for the fitting of a tamper indicating device in accordance with 10 CFR 71.43(b). The lid may also be further secured, to prevent unauthorized removal, by a padlock attached to a lock pin welded to the keg closure flange.

Due to the relatively low weight and size of the package, there are no specific design features to allow for the tie down and handling of the package.

An inner cork liner is fitted between the keg liner and the CV. The inner cork liner consists of a body and a top cork. There is no cork directly underneath the CV as it sits on the keg liner. The top cork varies in thickness between 67.5 mm and 85.5 mm; the variation in thickness is to accommodate the design of the CV lid. The side wall thickness of the inner cork varies from 30.5 mm at the top of the CV to 57 mm at the bottom of the CV. The surface of the cork is sealed with a water-based sealant to enhance its appearance and reduce the potential to produce dust.

1.2.1.3 3980 CV

The CV is composed of a body and a lid (see Figure 1-3).

The CV body is fabricated from three pieces of stainless steel: the CV flange/cavity wall, the CV outer wall and the CV base. Each piece is machined from solid. The CV flange/cavity wall is

welded to the CV outer wall to form the cavity into which the body lead shielding is either cast, or a pre-machined component fitted. The base is then welded to the outer wall. Drawing 1C-6044 and 1C-9012 in Section 1.3.3 shows the general arrangement of the CV body.

The CV lid is fabricated from two pieces of stainless steel, the CV lid top and the CV lid shielding casing. Both pieces are machined from solid. The CV lid shielding casing has the shielding lead cast inside (or a pre-machined component fitted) to a depth of 22 mm; the CV lid shielding casing is then welded to the CV lid top. Drawing 1C-6045 in Section 1.3.3 shows the general arrangement of the CV lid.

The CV lid is held in position by eight recessed alloy steel screws. The seal between the CV body and the CV lid is effected by two EP O-ring seals of 3 mm cord diameter. Access to the interspace between the two O-rings is provided for operational and maintenance leak testing. Leak testing is required for the CV to ensure that it meets the regulatory release limits specified in 10 CFR 71.51.

The CV has a cavity of overall length of 109 mm and a diameter of 64.5 mm. The vessel operates at atmospheric pressure, although the internal pressure may vary due to heating of the gases within the CV by decay heat of the contents and atmospheric temperature and pressure changes.

1.2.1.4 Containment Boundary

Figure 1-5 shows the containment boundary of the Safkeg-LS 3979A package. As shown, the containment boundary consists of the CV flange/cavity wall, the CV lid top and the inner O-ring containment seal of CV. The containment seal is tested on manufacture, during periodic maintenance and in operation, to ensure it remains within regulatory limits regarding leak rate under both NCT and HAC. Section 4 discusses the containment boundary in further detail.

1.2.1.5 Gamma Shielding

Figure 1-4 shows the gamma shielding present in the Safkeg-LS 3979A package. Beta and Gamma shielding is provided principally by the lead present in the CV body and lid; the steel of the CV provides some additional shielding. The lead is cast in position inside the stainless steel cladding of the CV body and the CV lid. Therefore there are no gaps in the lead shielding or at the interface of the lead and steel parts. The CV is designed so that the shielding in the lid and body are stepped to reduce radiation streaming. The upstanding ring on the lid also provides some additional steel shielding to reduce the radiation streaming from the gap between the CV Lid and CV Body.



The contents of the package are defined as everything that is carried within the CV cavity. For all contents, one of the inserts specified in Section 1.2.2.2 and shown in Figure 1-7, Figure 1-8 or Figure 1-9, is required. These inserts provide different amounts of shielding and also provide confinement for all contents under NCT and confinement for solid contents under HAC.

1.2.1.6 Energy Absorbing Features

The outer cork, top cork and inner cork provide insulation and energy absorption thus providing protection to the CV during NCT and HAC (see Figure 1-1, Figure 1-2).

The outer cork is located between the keg liner and the keg outer shell. The outer cork is protected by the keg liner and not intended to be replaced. The inner cork and top cork are

readily removable and intended to be replaced if required at pre-shipment or annual maintenance.

1.2.1.7 Heat Transfer Features

The contents of the Safkeg-LS 3979A package are limited to have a maximum heat output of 10 W for solid or gaseous contents. With such a small heat source no specific heat transfer design features are required.

Thermal protection of the contents from external heat sources such as insulation or fire is provided by the outer cork, top cork and inner cork. During HAC, the keg is designed to vent by melting of the low melting point alloy in the fuse plug, thus preventing any pressure build up within the keg cavity due to gasses arising from pyrolysis of the cork.

1.2.1.8 Labelling

The keg is fitted with a name plate to comply with the requirement in 10 CFR 71.85 [1.2] and 49 CFR 172.310 [1.4].

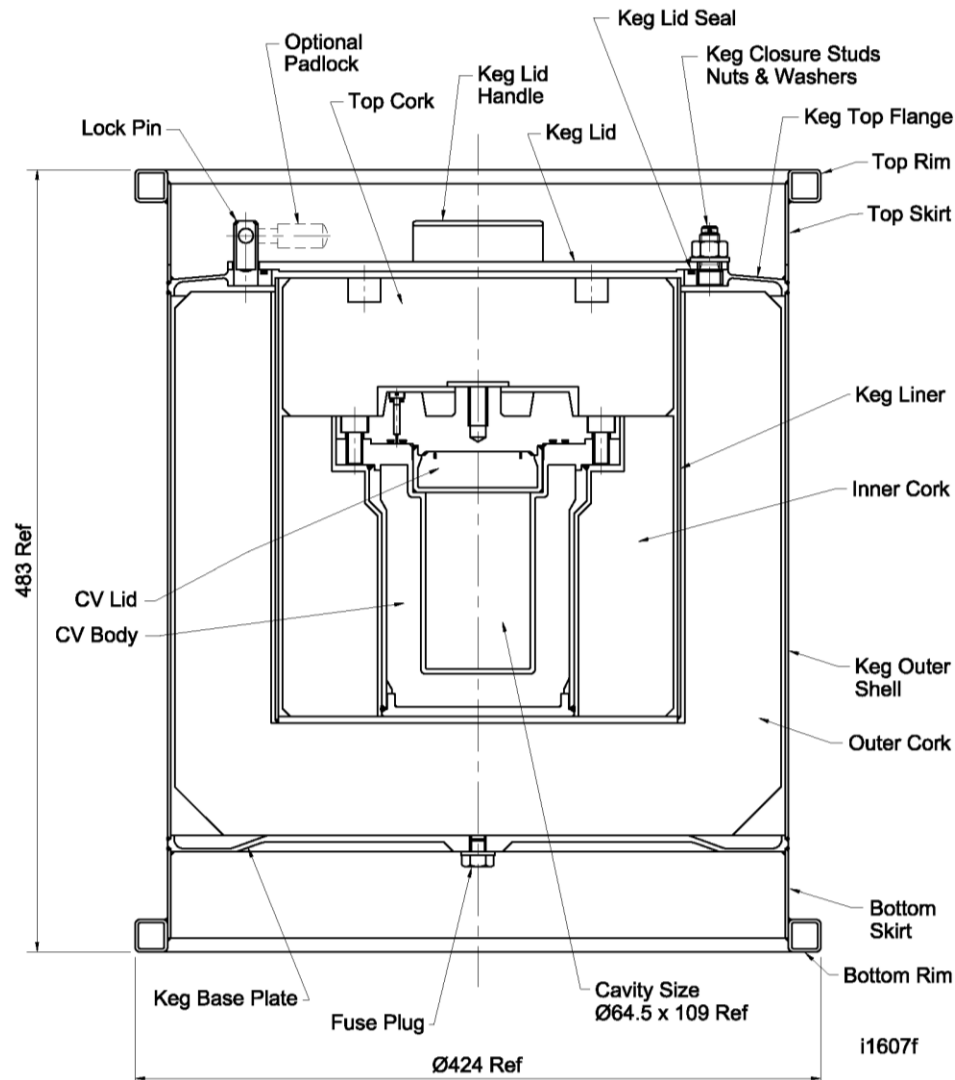
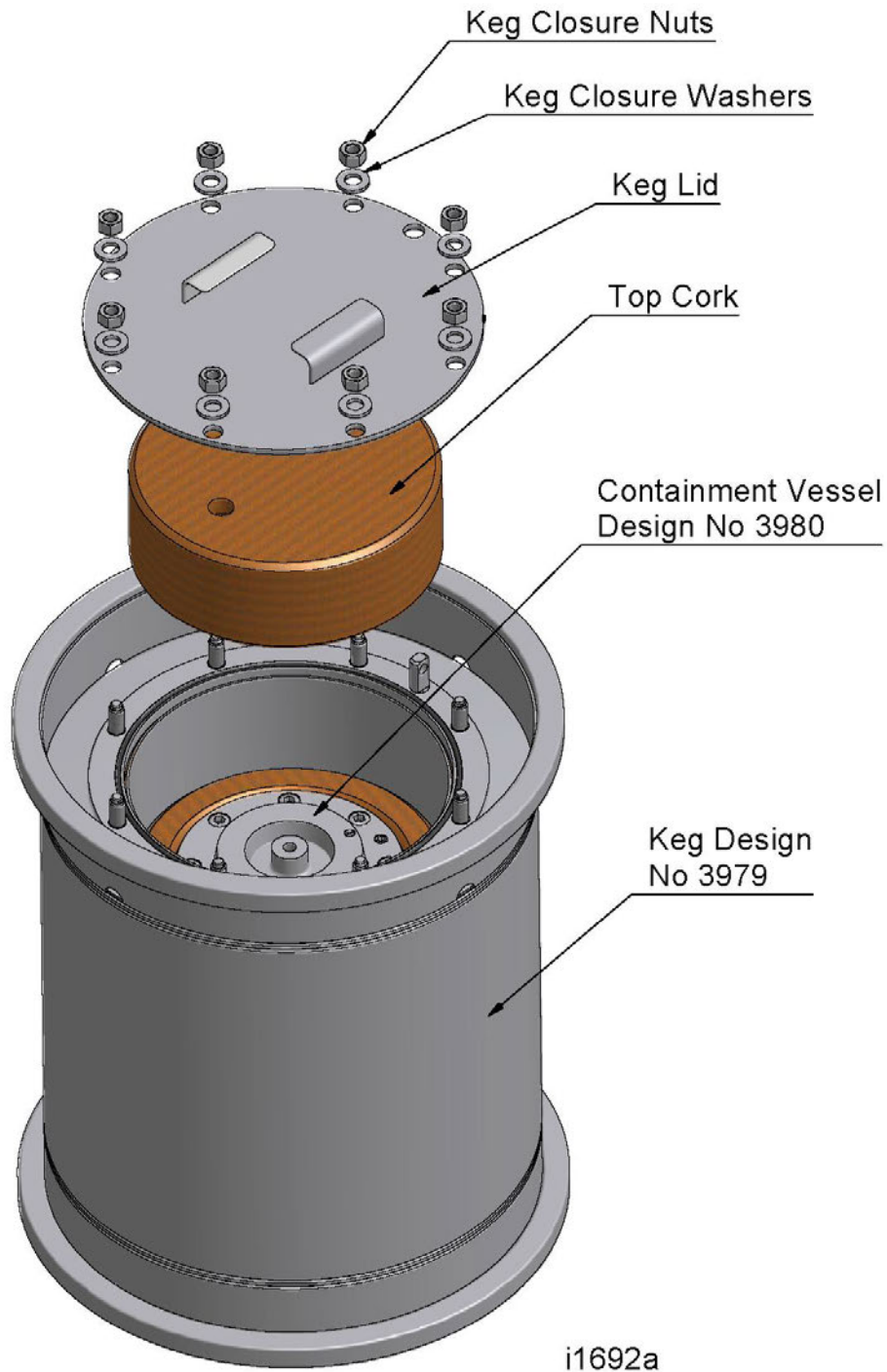

Figure 1-1 Safkeg-LS 3979A package – Section View and Nomenclature



Safkeg LS Design No 3979A

Figure 1-2 Safkeg-LS 3979A package – Isometric view

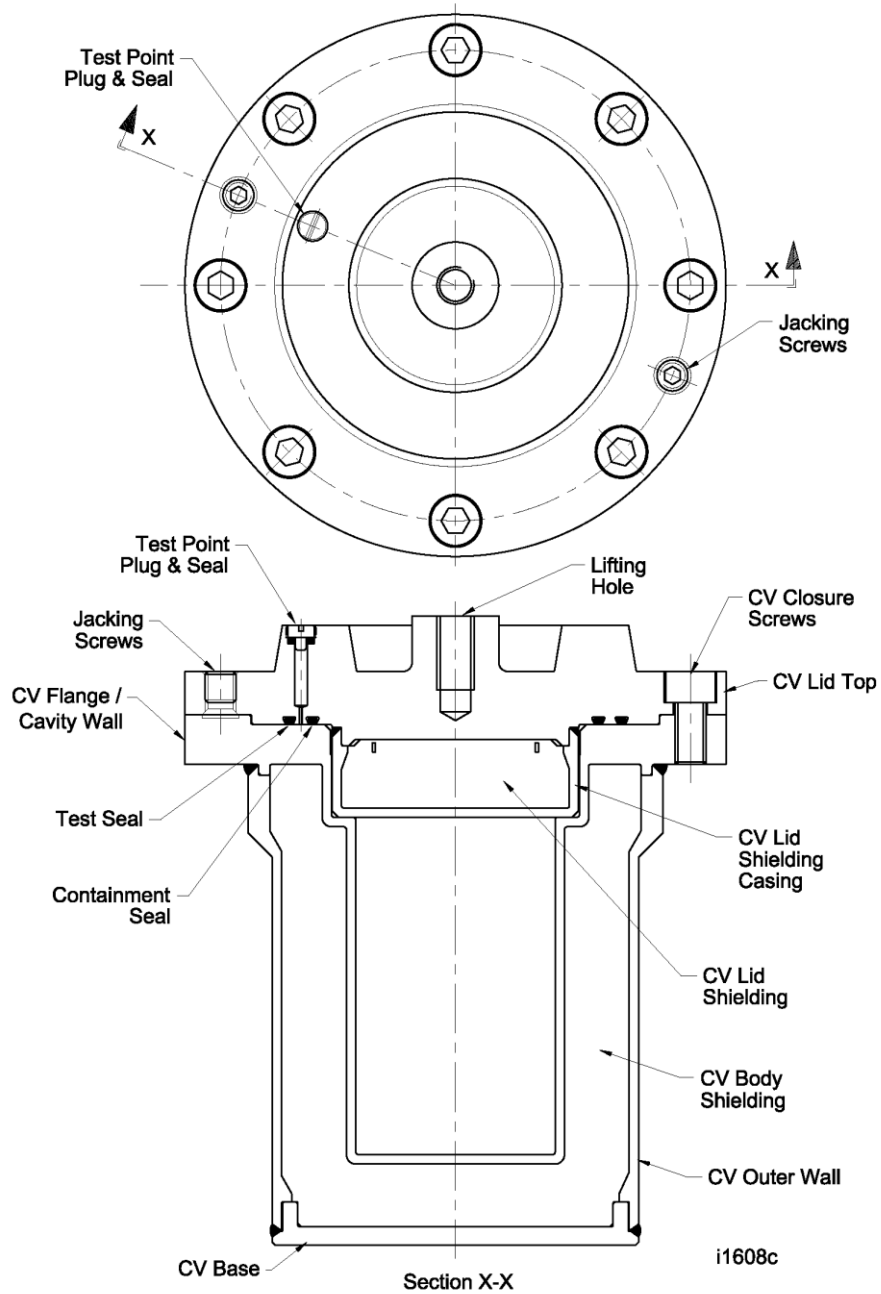
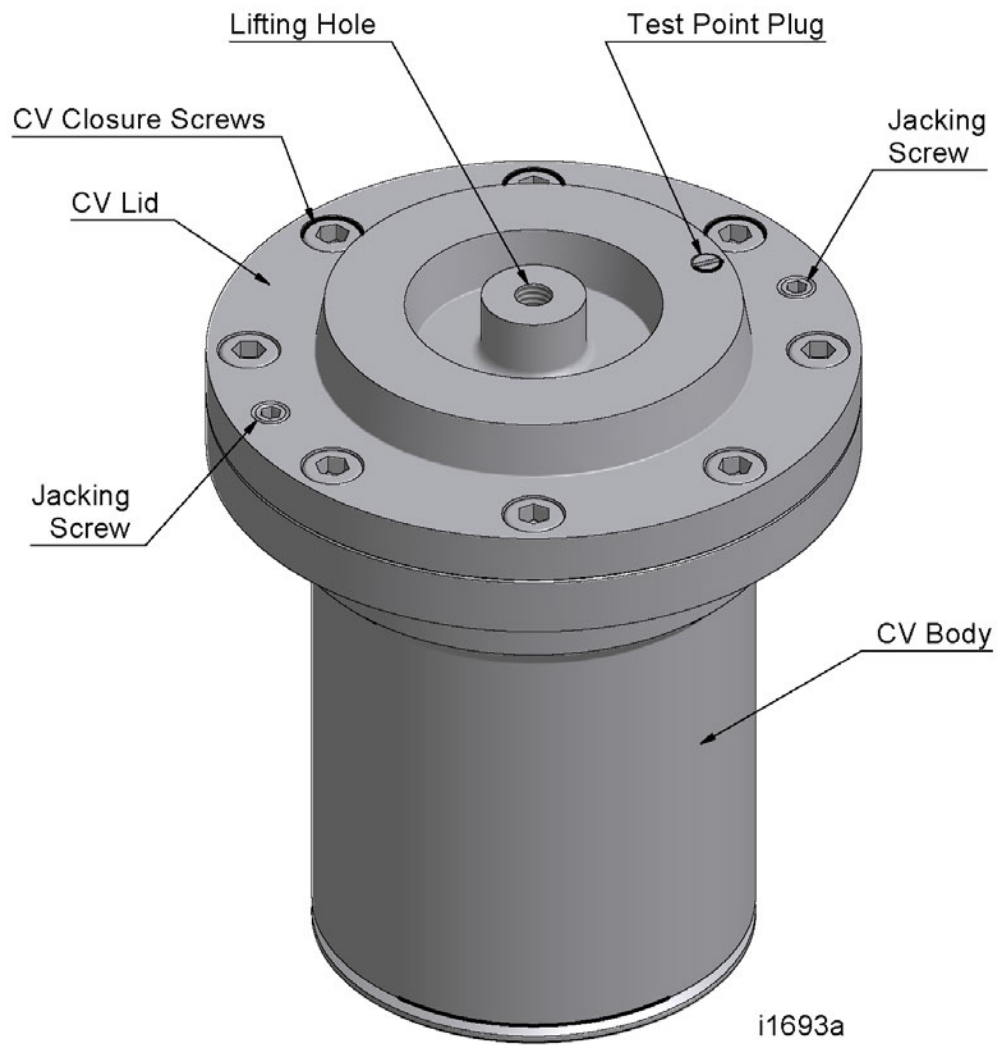

Figure 1-3 3980 CV – Top and Section View and Nomenclature



Containment Vessel Design No 3980

Figure 1-4 3980 CV – Isometric View

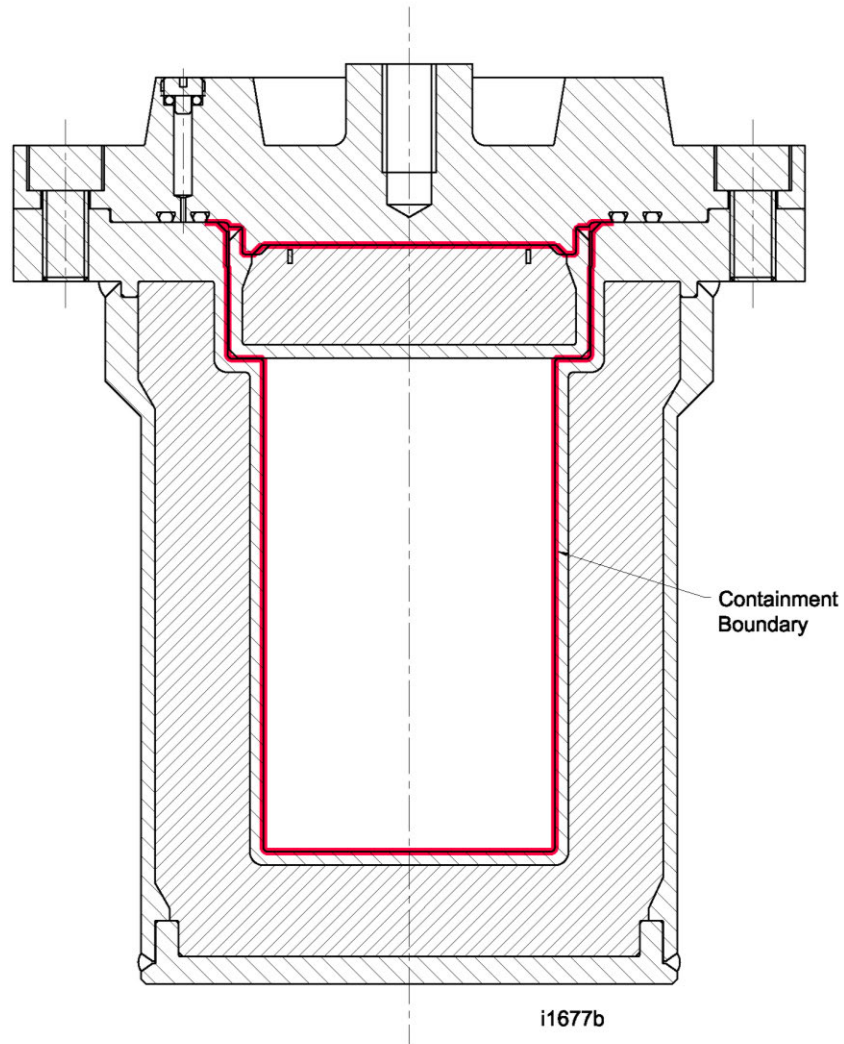

Figure 1-5 Containment boundary of the Safkeg-LS 3979A package

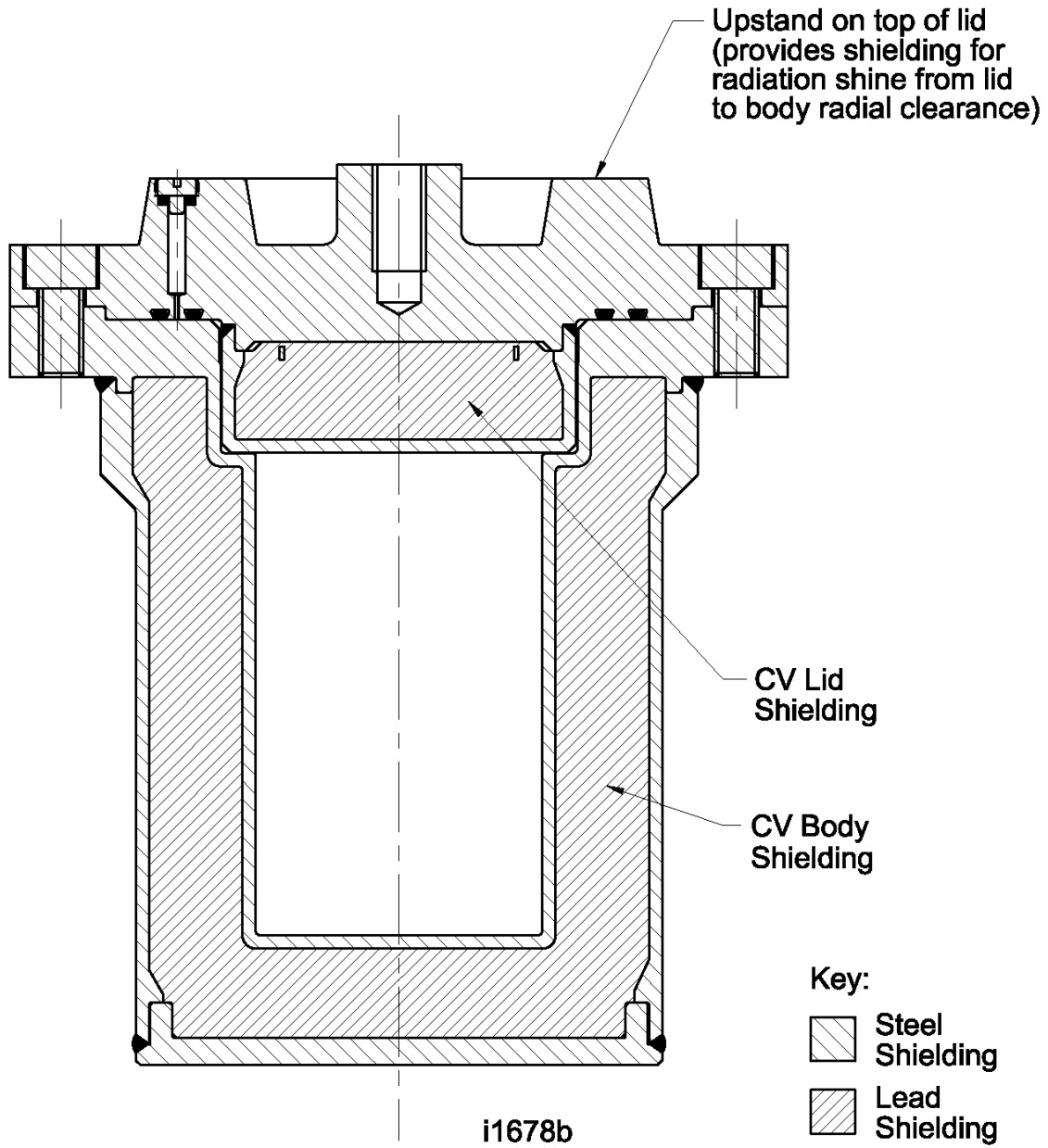

Figure 1-6 Gamma shielding present in the Safkeg-LS 3979A package

1.2.2 Contents

1.2.2.1 Contents - General

The Safkeg-LS 3979A package is designed as a general purpose package for radioactive material that requires no shielding or limited shielding. The inserts provide additional shielding for radioactive material that requires a significant amount of shielding.

The package is designed for radioactive material that emits alpha, beta or gamma radiation. The specified contents do not include materials that emit a significant amount of neutrons.

The contents may be in solid or gaseous form.

The contents may also include non-radioactive materials associated with the radioactive materials, such as contents holders or fixtures and packing materials. The radioactive material may be enclosed in any convenient product container such as a quartz vial or aluminum capsule. Irradiated items may be carried in plastic or metal can or wrapping to minimize the contamination of the insert.

Fissile materials and irradiated fissile materials containing fission products are permitted within the limits specified in Table 1-9.

Pyrophoric materials are permitted under the conditions specified.

As the maximum contents are $> 3,000 A_2$, the package is designated as Category I as defined in NUREG 1609 [1.1].

The maximum activity of the radioactive contents is limited principally by the radiation shielding.

The contents heat limit is 10 W for solid or gaseous contents.

The contents will be carried in a product container appropriate for the contents and chosen by the shipper.

The product containers will, in all cases, be carried in shielding inserts as specified in the licensing drawings in section 1.3.3.

The maximum mass of all material (radioactive contents, product capsules or containers, shielding inserts, and all associated items such as product container holders and packing) inside the CV is 5.8 kg (13 lbs).

Various restrictions and limits of quantity of radionuclides apply according to the insert used and the form of the radioactive material (solid or gas). These restrictions and contents limits are detailed in Section 1.2.2 in the tables for the different Contents Types (eg CT-1).

The maximum pressure assumed for the CV under NCT and HAC is 7 barg (100 psig): this is the design envelope.

1.2.2.2 Inserts

The inserts, which are required for all contents (in suitable product containers), provide different degrees of shielding and confinement under NCT.

The inserts are as shown in Figure 1-7, Figure 1-8 or Figure 1-9. The weights of the inserts and the contents of the inserts are given in Table 1-1. The maximum mass of the contents is determined by calculating the mass of steel which would completely fill the cavity of the insert.

Table 1-1 Maximum mass of the radionuclides

Shielding Insert	Mass of Insert	Maximum Mass of Contents	Mass of insert + Maximum mass of contents
	g	g	kg (rounded)
LS-12x65-Tu Design No 3984	5,750	57	5.8
LS-31x73-Tu Design No 3983	4,860	429	5.3
LS-50x103-SS Design No 3986	970	1,570	2.5

The insert designation is coded as below.

1st 2 letters eg LS Designate the insert fits the Safkeg-LS

Numbers eg 12x65 indicate the cavity size of the insert (dia mm x ht mm)

Last 2 letters Tu indicates tungsten and SS indicates stainless steel

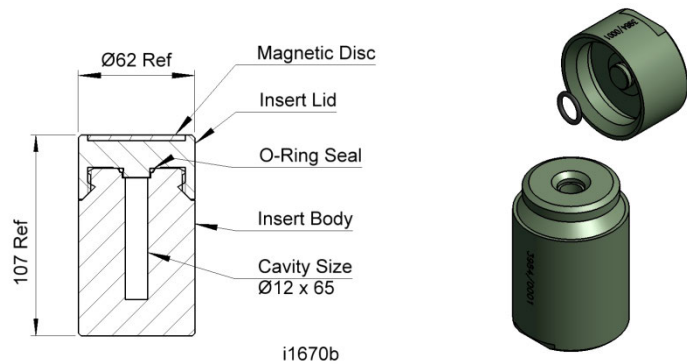

Figure 1-7 Shielding insert LS-12x65-Tu – Design # 3984

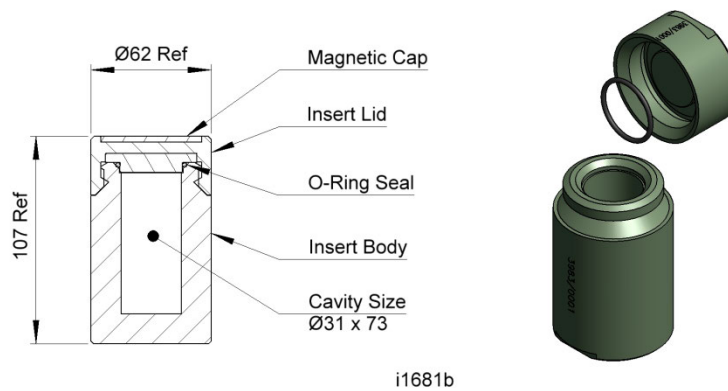

Figure 1-8 Shielding insert LS-31x73-Tu – Design # 3983

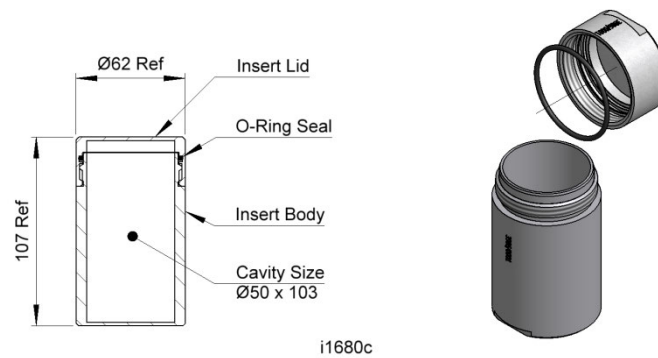

Figure 1-9 Shielding insert LS-50x103-SS – Design # 3986

1.2.2.3 Contents Types

The contents to be carried shall be as specified in the Contents Types listed in Table 1-2.

The general requirements for each Contents Types listed in Table 1-2 are given in Table 1-3 to Table 1-10. The package activity limit for each Contents Type is given in the Table 1-11 to Table 1-18. These tables specify the shipping limits for the package.

The activity limit for each nuclide given in Table 1-11 to Table 1-18 is determined as the least of the limits determined on the basis of heat output, mass limit, shielding limit and, for gas contents, the limit based on allowable leakage under NCT or HAC. The details of the determinations are given in report PCS 036 (Section 1.3.4).

The contents may include mixtures of activation products not listed in Table 1-11 to Table 1-13, provided the mixture of activation products does not exceed 0.25 x A2 and all other requirements in the certificate are met (Note. This section added as submitted under [1.9] and approved under Rev. 6 of the certificate [1.10]).

Note that the shipping limits must not exceed any of the limits in Table 1-2 to Table 1-10.

Table 1-2 Contents Types

Contents Type Designation	Material Form	Shielding Insert	General Requirements for each Contents Type	Activity Limits for each Contents Type
CT-1	Solid	LS-12x65-Tu Design No 3984	See Table 1-3	See Table 1-11
CT-2	Solid	LS-31x73-Tu Design No 3983	See Table 1-4	See Table 1-12
CT-3	Solid	LS-50x103-SS Design No 3986	See Table 1-5	See Table 1-13
CT-4	Removed	Not Used/approved		
CT-5	Removed	Not Used/approved		
CT-6	Gas	LS-31x73-Tu Design No 3983	See Table 1-8	See Table 1-16
CT-7	Solid/ Fissile Normal Form	LS-50x103-SS Design No 3986	See Table 1-9	See Table 1-17
CT-8	Solid/ Fissile Special Form	LS-50x103-SS Design No 3986	See Table 1-10	See Table 1-18

Table 1-3 CT-1 – Solid in heavy tungsten insert (LS-12x65-Tu Design No 3984)

Parameter	Restrictions
Contents Type name	CT-8 – Fissile solid in steel insert

Parameter	Restrictions
Comments on contents	Fissile samples and standards in Special Form
Insert in CV cavity	LS-50x103-SS Design No 3986 (mass 570g)
Maximum quantity of radioactive material	See Table 1-11 (subject to the limits below which provide a maximum for each case) Limit for air transport is A2 in accordance with 10CFR 71.88
Maximum mass of radioactive material	800g (subject to the limits below which provide a maximum for each case)
Mixtures of radionuclides	Mixtures of the nuclides are allowed providing that the sum of the proportionate amounts of each nuclide with respect to the quantity shown does not exceed unity.
Maximum decay heat of radioactive material	10W
Maximum quantity of fissile material	Contents limited to the quantities specified in the following references. 10CFR 71.15 Exemption from classification as fissile material 10CFR 71.22 General license: Fissile material 10CFR 71.23 General license: Plutonium-beryllium special form material.
Physical form of radioactive material	Solid in Special Form
Chemical form of radioactive material	Element or compound
Pyrophoric contents	The contents may be pyrophoric.
Product containers	The radioactive material may be carried in any convenient product container such as a quartz vial or aluminum capsule. Irradiated items may be carried in plastic or metal can or wrapping to minimize the contamination of the insert.
Location of radioactive material	Within the shielding insert
Maximum weight of contents of the CV	2.5 kg This includes the insert, radioactive material, product containers and any other packing.
Maximum weight of contents of the insert	1,570g
Loading restrictions	None

Table 1-4 CT-2 – Solid in light tungsten insert (LS-31x73-Tu Design No 3983)

Parameter	Restrictions
Contents Type name	CT-2 – Solid in light tungsten insert
Comments on contents	General use including bulk medical and industrial source material.
Insert in CV cavity	LS-31x73-Tu Design No 3983 (mass 4,860g)
Maximum quantity of radioactive material	See Table 1-12
Maximum mass of radioactive material	200g
Mixtures of radionuclides	Mixtures of the nuclides are allowed providing that the sum of the proportionate amounts of each nuclide with respect to the quantity shown does not exceed unity.
Maximum decay heat of radioactive material	10W
Maximum quantity of fissile material	None
Physical form of radioactive material	Solid with melting point > 250°C and not to be volatile at < 250°C.
Chemical form of radioactive material	Element or compound Compound only for Cs, Hg, I, Na and P.
Pyrophoric contents	The contents may be pyrophoric.
Product containers	The radioactive material may be carried in any convenient product container such as a quartz vial or aluminum capsule. Irradiated items may be carried in plastic or metal can or wrapping to minimize the contamination of the insert.
Location of radioactive material	Within the shielding insert
Maximum weight of contents of the CV	5.3 kg This includes the insert, radioactive material, product containers and any other packing.
Maximum weight of contents of the insert	429g
Loading restrictions	None

Table 1-5 CT-3 – Solid in steel insert (LS-50x103-SS Design No 3986)

Parameter	Restrictions
Contents Type name	CT-3 – Solid in steel insert
Comments on contents	General use including bulk medical and industrial source material.
Insert in CV cavity	LS-50x103-SS Design No 3986 (mass 570g)

Parameter	Restrictions
Maximum quantity of radioactive material	See Table 1-13
Maximum mass of radioactive material	800g
Mixtures of radionuclides	Mixtures of the nuclides are allowed providing that the sum of the proportionate amounts of each nuclide with respect to the quantity shown does not exceed unity.
Maximum decay heat of radioactive material	10W
Maximum quantity of fissile material	None
Physical form of radioactive material	Solid with melting point > 250°C and not to be volatile at < 250°C.
Chemical form of radioactive material	Element or compound Compound only for Cs, Hg, I, Na and P.
Pyrophoric contents	The contents may be pyrophoric.
Product containers	The radioactive material may be carried in any convenient product container such as a quartz vial or aluminum capsule. Irradiated items may be carried in plastic or metal can or wrapping to minimize the contamination of the insert.
Location of radioactive material	Within the shielding insert
Maximum weight of contents of the CV	2.5 kg This includes the insert, radioactive material, product containers and any other packing.
Maximum weight of contents of the insert	1,570g
Loading restrictions	None

Table 1-6 CT-4 - Liquid in light tungsten insert (LS-31x73-Tu Design No 3983)

Parameter	Restrictions
Table Removed, CT-4 not used/approved	

Table 1-7 CT-5 – Liquid in steel insert (LS-50x103-SS Design No 3986)

Parameter	Restrictions
Table Removed, CT-5 not used/approved	

Table 1-8 CT-6 – Gas in light tungsten insert (LS-31x73-Tu Design No 3983)

Parameter	Restrictions
Contents Type name	CT-6 – Gas in light tungsten insert
Comments on contents	General use including bulk medical material.
Insert in CV cavity	LS-31x73-Tu Design No 3983 (mass 4,860g)
Maximum quantity of radioactive material	See Table 1-16
Maximum mass of radioactive material	Mass < 1g
Mixtures of radionuclides	Mixtures of the nuclides are allowed providing that the sum of the proportionate amounts of each nuclide with respect to the quantity shown does not exceed unity.
Maximum decay heat of radioactive material	10W
Maximum quantity of fissile material	None
Physical form of radioactive material	Gas
Chemical form of radioactive material	Elemental gas
Pyrophoric contents	Not applicable
Product containers	The product container shall be a quartz vial sealed by fusing or an aluminum capsule. The product container may be carried in packing (such as a plastic or metal can or wrapping) to minimize the contamination of the insert. The volume of the product containers and packing shall be <10cc.
Location of radioactive material	Within the shielding insert
Maximum weight of contents of the CV	5.3 kg This includes the insert, radioactive material, product containers and any other packing.
Maximum weight of contents of the insert	429g
Loading restrictions	None

Table 1-9 CT-7 – Fissile solid in Normal Form in steel insert (LS-50x103-SS Design No 3986)

Parameter	Restrictions
Contents Type name	CT-7 – Fissile solid in steel insert
Comments on contents	Fissile samples and standards
Insert in CV cavity	LS-50x103-SS Design No 3986 (mass 570g)
Maximum quantity of radioactive material	See Table 1-17 (subject to the limits below which provide a maximum for each case)

Parameter	Restrictions
	Limit for air transport is A2 in accordance with 10CFR 71.88
Maximum mass of radioactive material	800g (subject to the limits below which provide a maximum for each case)
Mixtures of radionuclides	Mixtures of the nuclides are allowed providing that the sum of the proportionate amounts of each nuclide with respect to the quantity shown does not exceed unity.
Maximum decay heat of radioactive material	10W
Maximum quantity of fissile material	Contents limited to the quantities specified in the following references. 10CFR 71.15 Exemption from classification as fissile material 10CFR 71.22 General license: Fissile material 10CFR 71.23 General license: Plutonium-beryllium special form material.
Physical form of radioactive material	Solid in Normal Form with melting point > 250°C and not to be volatile at < 250°C.
Chemical form of radioactive material	Element or compound
Pyrophoric contents	The contents may be pyrophoric.
Product containers	The radioactive material may be carried in any convenient product container such as a quartz vial or aluminum capsule. Irradiated items may be carried in plastic or metal can or wrapping to minimize the contamination of the insert.
Location of radioactive material	Within the shielding insert
Maximum weight of contents of the CV	2.5 kg This includes the insert, radioactive material, product containers and any other packing.
Maximum weight of contents of the insert	1,570g
Loading restrictions	None

Table 1-10 CT-8 – Fissile solid in Special Form in steel insert (LS-50x103-SS Design No 3986)

Parameter	Restrictions
Contents Type name	CT-8 – Fissile solid in steel insert
Comments on contents	Fissile samples and standards in Special Form
Insert in CV cavity	LS-50x103-SS Design No 3986 (mass 570g)
Maximum quantity of radioactive material	See Table 1-18 (subject to the limits below which provide a maximum for each case)

Parameter	Restrictions
	Limit for air transport is A2 in accordance with 10CFR 71.88
Maximum mass of radioactive material	800g (subject to the limits below which provide a maximum for each case)
Mixtures of radionuclides	Mixtures of the nuclides are allowed providing that the sum of the proportionate amounts of each nuclide with respect to the quantity shown does not exceed unity.
Maximum decay heat of radioactive material	10W
Maximum quantity of fissile material	Contents limited to the quantities specified in the following references. 10CFR 71.15 Exemption from classification as fissile material 10CFR 71.22 General license: Fissile material 10CFR 71.23 General license: Plutonium-beryllium special form material.
Physical form of radioactive material	Solid in Special Form
Chemical form of radioactive material	Element or compound
Pyrophoric contents	The contents may be pyrophoric.
Product containers	The radioactive material may be carried in any convenient product container such as a quartz vial or aluminum capsule. Irradiated items may be carried in plastic or metal can or wrapping to minimize the contamination of the insert.
Location of radioactive material	Within the shielding insert
Maximum weight of contents of the CV	2.5 kg This includes the insert, radioactive material, product containers and any other packing.
Maximum weight of contents of the insert	1,570g
Loading restrictions	None

Table 1-11 CT-1 – Solid in heavy tungsten insert (LS-12x65-Tu) #3984 – Activity Limits

Contents Type 1 - CT-1 - Solid in heavy tungsten insert

1	2	3	4	5	6	7	8	9	10
Nuclide	Max TBq	Activity Ci	A2 TBq	# A2s	Spec Ac TBq/g	Mass g	Heat gen W/Ci	Heat output W	PackageType A or B
Ac-225	1.22E-01	3.29E+00	6.00E-03	20.29	2.10E+03	5.80E-05	3.46E-02	1.14E-01	B

Contents Type 1 - CT-1 - Solid in heavy tungsten insert

1	2	3	4	5	6	7	8	9	10
Nuclide	Max TBq	Activity Ci	A2 TBq	# A2s	Spec Ac TBq/g	Mass g	Heat gen W/Ci	Heat output W	PackageType A or B
Ac-227	8.38E-01	2.27E+01	9.00E-05	9311.69	2.70E+00	3.10E-01	4.72E-04	1.07E-02	B
Ac-228	1.07E-02	2.89E-01	5.00E-01	0.02	8.40E+04	1.27E-07	8.04E-03	2.32E-03	A
Am-241	3.90E+00	1.05E+02	1.00E-03	3900.00	1.30E-01	3.00E+01	3.28E-02	3.46E+00	B
As-77	1.95E+02	5.28E+03	7.00E-01	278.86	3.90E+04	5.01E-03	1.41E-03	7.41E+00	B
Au-198	2.33E+00	6.29E+01	6.00E-01	3.88	9.00E+03	2.59E-04	4.34E-03	2.73E-01	B
Ba-131	4.52E-01	1.22E+01	2.00E+00	0.23	3.10E+03	1.46E-04	3.06E-03	3.73E-02	A
C-14	4.80E+00	1.30E+02	3.00E+00	1.60	1.60E-01	3.00E+01	2.93E-04	3.80E-02	B
Co-60	2.28E-03	6.17E-02	4.00E-01	0.01	4.20E+01	5.44E-05	1.54E-02	9.52E-04	A
Cs-131	2.24E+03	6.05E+04	3.00E+01	74.58	3.80E+03	5.89E-01	1.65E-04	1.00E+01	B
Cs-134	2.24E-02	6.06E-01	7.00E-01	0.03	4.80E+01	4.67E-04	1.02E-02	6.17E-03	A
Cs-137	1.42E-01	3.83E+00	6.00E-01	0.24	3.20E+00	4.43E-02	1.01E-03	3.88E-03	A
Cu-67	2.30E+02	6.22E+03	7.00E-01	328.92	2.80E+04	8.22E-03	1.61E-03	1.00E+01	B
Hg-203	1.86E+02	5.03E+03	1.00E+00	185.96	5.10E+02	3.65E-01	1.99E-03	1.00E+01	B
Ho-166	2.42E-01	6.53E+00	4.00E-01	0.60	2.60E+04	9.30E-06	4.29E-03	2.80E-02	A
I-125	1.06E+03	2.87E+04	3.00E+00	354.17	6.40E+02	1.66E+00	3.48E-04	1.00E+01	B
I-129	1.95E-04	5.27E-03	unlimited	unlimited	6.50E-06	3.00E+01	4.68E-04	2.47E-06	B
I-131	1.34E+00	3.62E+01	7.00E-01	1.91	4.60E+03	2.91E-04	3.39E-03	1.23E-01	B
In-111	1.42E+02	3.85E+03	3.00E+00	47.45	1.50E+04	9.49E-03	2.60E-03	1.00E+01	B
Ir-192	9.60E-01	2.59E+01	6.00E-01	1.60	3.40E+02	2.82E-03	6.13E-03	1.59E-01	B
Ir-194	2.58E-01	6.96E+00	3.00E-01	0.86	3.10E+04	8.31E-06	5.35E-03	3.72E-02	A
Lu-177	3.43E+02	9.27E+03	7.00E-01	490.10	4.10E+03	8.37E-02	1.08E-03	1.00E+01	B
Mo-99	2.80E-01	7.58E+00	6.00E-01	0.47	1.80E+04	1.56E-05	3.27E-03	2.48E-02	A
Na-24	7.80E-04	2.11E-02	2.00E-01	0.00	3.20E+05	2.44E-09	2.77E-02	5.85E-04	A
Np-237	7.80E-04	2.11E-02	2.00E-03	0.39	2.60E-05	3.00E+01	2.88E-02	6.07E-04	A
P-32	1.90E-02	5.12E-01	5.00E-01	0.04	1.10E+04	1.72E-06	4.12E-03	2.11E-03	A
P-33	8.15E+02	2.20E+04	1.00E+00	814.82	5.80E+03	1.40E-01	4.54E-04	1.00E+01	B
Pb-203	1.45E+01	3.91E+02	3.00E+00	4.83	1.10E+04	1.32E-03	2.14E-03	8.35E-01	B
Pb-210	8.40E+01	2.27E+03	5.00E-02	1680.00	2.80E+00	3.00E+01	2.31E-04	5.24E-01	B
Pd-109	1.73E+02	4.67E+03	5.00E-01	345.39	7.90E+04	2.19E-03	2.14E-03	1.00E+01	B
Ra-223	8.46E-01	2.29E+01	7.00E-03	120.84	1.90E+03	4.45E-04	3.50E-02	8.00E-01	B
Ra-224	3.33E-03	8.99E-02	2.00E-02	0.17	5.90E+03	5.64E-07	3.37E-02	3.03E-03	A
Ra-226	3.62E-03	9.79E-02	3.00E-03	1.21	3.70E-02	9.79E-02	2.84E-02	2.78E-03	B
Re-186	1.38E+02	3.74E+03	6.00E-01	230.66	6.90E+03	2.01E-02	2.14E-03	8.00E+00	B
Re-188	5.74E-01	1.55E+01	4.00E-01	1.43	3.60E+04	1.59E-05	4.97E-03	7.70E-02	B
Rh-105	2.71E+02	7.31E+03	8.00E-01	338.13	3.10E+04	8.73E-03	1.37E-03	1.00E+01	B
Se-75	1.54E+02	4.16E+03	3.00E+00	51.27	5.40E+02	2.85E-01	2.41E-03	1.00E+01	B
Sm-153	1.90E+02	5.15E+03	6.00E-01	317.41	1.60E+04	1.19E-02	1.94E-03	1.00E+01	B
Sr-89	1.07E+02	2.89E+03	6.00E-01	178.41	1.10E+03	9.73E-02	3.46E-03	1.00E+01	B
Sr-90	1.62E+01	4.37E+02	3.00E-01	53.92	5.10E+00	3.17E+00	3.46E-03	1.51E+00	B
Tb-161	3.19E+02	8.62E+03	2.00E-02	15948.28	4.35E+03	7.33E-02	1.16E-03	1.00E+01	B



Contents Type 1 - CT-1 - Solid in heavy tungsten insert

1	2	3	4	5	6	7	8	9	10
Nuclide	Max TBq	Activity Ci	A2 TBq	# A2s	Spec Ac TBq/g	Mass g	Heat gen W/Ci	Heat output W	PackageType A or B
Th-227	1.79E+00	4.85E+01	5.00E-03	358.70	1.10E+03	1.63E-03	3.59E-02	1.74E+00	B
Th-228	2.53E-03	6.84E-02	1.00E-03	2.53	3.00E+01	8.44E-05	3.21E-02	2.20E-03	B
Tl-201	4.84E+02	1.31E+04	4.00E+00	120.90	7.90E+03	6.12E-02	7.65E-04	1.00E+01	B
W-187	1.96E-01	5.31E+00	3.00E-01	0.65	2.60E+04	7.55E-06	4.54E-03	2.41E-02	A
W-188	6.02E-01	1.63E+01	6.00E-01	1.00	3.70E+02	1.63E-03	5.98E-04	9.73E-03	B
Y-90	8.76E-03	2.37E-01	3.00E-01	0.03	2.00E+04	4.38E-07	5.54E-03	1.31E-03	A
Yb-169	1.47E+02	3.98E+03	1.00E+00	147.37	8.90E+02	1.66E-01	2.51E-03	1.00E+01	B
Yb-175	3.69E+02	9.96E+03	9.00E-01	409.64	6.60E+03	5.59E-02	1.00E-03	1.00E+01	B
Max	2.24E+03	6.05E+04		1.59E+04		3.00E+01		1.00E+01	

Notes

Column

- 1 Identifies nuclide
- 2 Package activity limit for this Contents Type
- 3 Calculated from Bq amount in Col 2
- 4 A2 from 10CFR71
- 5 # of A2's of nuclide at package activity limit
- 6 Specific activity from 10CFR71
- 7 Mass of nuclide at package activity limit
- 8 Heat generation rate of nuclide - from Microshield.
- 9 Heat output of nuclide at package activity limit
- 10 Package Type [A or B] based on individual nuclide limit

Table 1-12 CT-2 – Solid in light tungsten insert (LS-31x73-Tu) #3983 – Activity Limits

Contents Type 2 - CT-2 - Solid in light tungsten insert

Nuclide	Package Limits		A2	# A2s		Spec Ac	Mass		Heat gen		Heat output	Package Type
	non-exclusive use	exclusive use	TBq	non-exclusive use	exclusive use	TBq/g	non-exclusive use	exclusive use	W/Bq	W/Ci	W	A or B
	Bq	Bq		g	g							
Ac-225	7.89E+10	3.94E+11	6.00E-03	1.31E+01	6.57E+01	2.10E+03	3.76E-05	1.88E-04	4.55E-12	1.68E-01	1.79E+00	B
Ac-227	2.51E+11	1.25E+12	9.00E-05	2.79E+03	1.39E+04	2.70E+00	9.29E-02	4.64E-01	8.42E-14	3.12E-03	1.06E-01	B
Ac-228	7.38E+09	3.69E+10	5.00E-01	1.48E-02	7.38E-02	8.40E+04	8.78E-08	4.39E-07	2.11E-13	7.80E-03	7.78E-03	A
Am-241	1.13E+13	1.13E+13	1.00E-03	1.13E+04	1.13E+04	1.30E-01	8.66E+01	8.66E+01	8.88E-13	3.29E-02	1.00E+01	B
As-77	3.56E+13	1.78E+14	7.00E-01	5.08E+01	2.54E+02	3.90E+04	9.12E-04	4.56E-03	3.75E-14	1.39E-03	6.67E+00	B
Au-198	1.49E+12	7.43E+12	6.00E-01	2.48E+00	1.24E+01	9.00E+03	1.65E-04	8.26E-04	1.17E-13	4.33E-03	8.70E-01	B
Ba-131	1.81E+11	9.06E+11	2.00E+00	9.06E-02	4.53E-01	3.10E+03	5.85E-05	2.92E-04	8.83E-14	3.27E-03	8.00E-02	A
Bi-210	1.28E+14	1.60E+14	6.00E-01	2.14E+02	2.67E+02	4.60E+03	2.79E-02	3.49E-02	6.23E-14	2.31E-03	1.00E+01	B
Bi-213	8.01E+11	4.00E+12	9.00E-05	8.90E+03	4.45E+04	7.13E+05	1.12E-06	5.62E-06	1.11E-13	4.11E-03	4.45E-01	B
C-14	3.20E+13	3.20E+13	3.00E+00	1.07E+01	1.07E+01	1.60E-01	2.00E+02	2.00E+02	7.92E-15	2.93E-04	2.54E-01	B
Cm-244	8.81E+11	4.41E+12	2.00E-03	4.41E+02	2.20E+03	3.00E+00	2.94E-01	1.47E+00	9.30E-13	3.44E-02	4.10E+00	B
Co-60	1.52E+09	7.58E+09	4.00E-01	3.79E-03	1.90E-02	4.20E+01	3.61E-05	1.80E-04	4.17E-13	1.54E-02	3.16E-03	A
Cr-51	8.59E+14	1.70E+15	3.00E+01	2.86E+01	5.67E+01	3.40E+03	2.53E-01	5.00E-01	5.88E-15	2.18E-04	1.00E+01	B
Cs-131	2.12E+15	2.12E+15	3.00E+01	7.05E+01	7.05E+01	3.80E+03	5.57E-01	5.57E-01	4.73E-15	1.75E-04	1.00E+01	B
Cs-134	1.25E+10	6.26E+10	7.00E-01	1.79E-02	8.95E-02	4.80E+01	2.61E-04	1.30E-03	2.75E-13	1.02E-02	1.72E-02	A
Cs-137	6.82E+10	3.41E+11	6.00E-01	1.14E-01	5.68E-01	3.20E+00	2.13E-02	1.06E-01	1.36E-13	5.04E-03	4.64E-02	A
Cu-64	3.53E+11	1.77E+12	1.00E+00	3.53E-01	1.77E+00	1.40E+05	2.52E-06	1.26E-05	4.97E-14	1.84E-03	8.78E-02	B
Cu-67	2.35E+14	2.35E+14	7.00E-01	3.36E+02	3.36E+02	2.80E+04	8.39E-03	8.39E-03	4.26E-14	1.58E-03	1.00E+01	B
Er-169	6.03E+14	6.03E+14	1.00E+00	6.03E+02	6.03E+02	3.10E+03	1.94E-01	1.94E-01	1.66E-14	6.14E-04	1.00E+01	B
Eu-152	5.06E+09	2.53E+10	1.00E+00	5.06E-03	2.53E-02	6.50E+00	7.79E-04	3.89E-03	2.09E-13	7.73E-03	5.29E-03	A
Eu-154	4.52E+09	2.26E+10	6.00E-01	7.53E-03	3.77E-02	9.80E+00	4.61E-04	2.31E-03	2.44E-13	9.02E-03	5.51E-03	A
Eu-155	4.96E+14	4.96E+14	3.00E+00	1.65E+02	1.65E+02	1.80E+01	2.75E+01	2.75E+01	2.02E-14	7.46E-04	1.00E+01	B
Eu-156	2.83E+09	1.42E+10	7.00E-01	4.05E-03	2.02E-02	2.00E+03	1.42E-06	7.08E-06	2.71E-13	1.00E-02	3.84E-03	A
Fe-55	1.07E+16	1.07E+16	4.00E+01	2.67E+02	2.67E+02	8.80E+01	1.22E+02	1.22E+02	9.35E-16	3.46E-05	1.00E+01	B
Fe-59	3.63E+09	1.82E+10	9.00E-01	4.04E-03	2.02E-02	1.80E+03	2.02E-06	1.01E-05	2.09E-13	7.74E-03	3.80E-03	A
Ga-72	1.30E+09	6.48E+09	4.00E-01	3.24E-03	1.62E-02	1.10E+05	1.18E-08	5.89E-08	5.15E-13	1.90E-02	3.33E-03	A
Gd-152	1.60E+02	1.60E+02	9.00E-05	1.78E-06	1.78E-06	8.01E-13	2.00E+02	2.00E+02	3.44E-13	1.27E-02	5.51E-11	A
Gd-153	4.18E+14	4.18E+14	9.00E+00	4.65E+01	4.65E+01	1.30E+02	3.22E+00	3.22E+00	2.39E-14	8.84E-04	1.00E+01	B
Hf-177m	1.01E+13	2.23E+13	2.00E-02	5.07E+02	1.12E+03	7.61E+05	1.33E-05	2.94E-05	4.48E-13	1.66E-02	1.00E+01	B
Hg-203	1.85E+14	1.85E+14	1.00E+00	1.85E+02	1.85E+02	5.10E+02	3.63E-01	3.63E-01	5.40E-14	2.00E-03	1.00E+01	B
Ho-166	1.49E+11	7.47E+11	4.00E-01	3.73E-01	1.87E+00	2.60E+04	5.75E-06	2.87E-05	1.16E-13	4.31E-03	8.69E-02	B
I-125	1.01E+15	1.01E+15	3.00E+00	3.35E+02	3.35E+02	6.40E+02	1.57E+00	1.57E+00	9.95E-15	3.68E-04	1.00E+01	B
I-129	1.30E+09	1.30E+09	unlimited	N/A	N/A	6.50E-06	2.00E+02	2.00E+02	1.45E-14	5.35E-04	1.88E-05	B
I-131	4.81E+11	2.40E+12	7.00E-01	6.87E-01	3.43E+00	4.60E+03	1.04E-04	5.22E-04	9.21E-14	3.41E-03	2.21E-01	B
In-111	1.42E+14	1.42E+14	3.00E+00	4.72E+01	4.72E+01	1.50E+04	9.44E-03	9.44E-03	7.06E-14	2.61E-03	1.00E+01	B
Ir-192	2.85E+11	1.42E+12	6.00E-01	4.75E-01	2.37E+00	3.40E+02	8.38E-04	4.19E-03	1.66E-13	6.13E-03	2.36E-01	B
Ir-194	1.38E+11	6.92E+11	3.00E-01	4.61E-01	2.31E+00	3.10E+04	4.47E-06	2.23E-05	1.44E-13	5.34E-03	1.00E-01	B
La-140	1.49E+09	7.47E+09	4.00E-01	3.73E-03	1.87E-02	2.10E+04	7.11E-08	3.56E-07	4.55E-13	1.69E-02	3.40E-03	A
Lu-176m	4.48E+13	1.27E+14	2.00E-02	2.24E+03	6.33E+03	1.80E+05	2.49E-04	7.04E-04	7.90E-14	2.92E-03	1.00E+01	B
Lu-177	3.41E+14	3.41E+14	7.00E-01	4.87E+02	4.87E+02	4.10E+03	8.32E-02	8.32E-02	2.93E-14	1.08E-03	1.00E+01	B
Lu-177m	9.15E+12	4.58E+13	2.00E-02	4.58E+02	2.29E+03	1.69E+02	5.41E-02	2.70E-01	2.03E-13	7.52E-03	9.31E+00	B
Mn-54	1.24E+10	6.18E+10	1.00E+00	1.24E-02	6.18E-02	2.90E+02	4.26E-05	2.13E-04	1.35E-13	4.98E-03	8.32E-03	A
Mo-99	1.76E+11	8.79E+11	6.00E-01	2.93E-01	1.47E+00	1.80E+04	9.77E-06	4.88E-05	1.10E-13	4.06E-03	9.64E-02	B
Mo-101	3.15E+09	1.58E+10	2.00E-02	1.58E-01	7.88E-01	4.67E+06	6.75E-10	3.37E-09	3.24E-13	1.20E-02	5.11E-03	A
Na-24	5.80E+08	2.90E+09	2.00E-01	2.90E-03	1.45E-02	3.20E+05	1.81E-09	9.06E-09	7.49E-13	2.77E-02	2.17E-03	A
Ni-63	4.20E+14	4.20E+14	3.00E+01	1.40E+01	1.40E+01	2.10E+00	2.00E+02	2.00E+02	2.79E-15	1.03E-04	1.17E+00	B
Np-237	5.20E+09	5.20E+09	2.00E-03	2.60E+00	2.60E+00	2.60E-05	2.00E+02	2.00E+02	8.51E-13	3.15E-02	4.42E-03	B

Contents Type 2 - CT-2 - Solid in light tungsten insert

Nuclide	Package Limits		A2	# A2s		Spec Ac	Mass		Heat gen		Heat output	Package Type
	non-exclusive use	exclusive use	TBq	non-exclusive use	exclusive use	TBq/g	non-exclusive use	exclusive use	W/Bq	W/Ci	W	A or B
	Bq	Bq					g	g				
P-32	5.08E+12	2.54E+13	5.00E-01	1.02E+01	5.08E+01	1.10E+04	4.62E-04	2.31E-03	1.11E-13	4.12E-03	2.83E+00	B
P-33	8.17E+14	8.17E+14	1.00E+00	8.17E+02	8.17E+02	5.80E+03	1.41E-01	1.41E-01	1.22E-14	4.53E-04	1.00E+01	B
Pb-203	7.02E+12	3.51E+13	3.00E+00	2.34E+00	1.17E+01	1.10E+04	6.38E-04	3.19E-03	5.88E-14	2.18E-03	2.06E+00	B
Pb-210	1.10E+13	1.10E+13	5.00E-02	2.19E+02	2.19E+02	2.80E+00	3.91E+00	3.91E+00	9.12E-13	3.38E-02	1.00E+01	B
Pb-212	4.32E+09	2.16E+10	2.00E-01	2.16E-02	1.08E-01	5.10E+04	8.47E-08	4.24E-07	1.63E-12	6.02E-02	3.52E-02	A
Pd-103	1.04E+15	1.04E+15	4.00E+01	2.61E+01	2.61E+01	2.80E+03	3.73E-01	3.73E-01	9.58E-15	3.55E-04	1.00E+01	B
Pd-109	8.08E+13	1.39E+14	5.00E-01	1.62E+02	2.78E+02	7.90E+04	1.02E-03	1.76E-03	7.21E-14	2.67E-03	1.00E+01	B
Ra-223	2.53E+11	1.26E+12	7.00E-03	3.61E+01	1.80E+02	1.90E+03	1.33E-04	6.65E-04	4.49E-12	1.66E-01	5.67E+00	B
Ra-224	3.05E+09	1.52E+10	2.00E-02	1.52E-01	7.62E-01	5.90E+03	5.17E-07	2.58E-06	3.76E-12	1.39E-01	5.74E-02	A
Ra-225	1.73E+11	8.64E+11	4.00E-03	4.32E+01	2.16E+02	1.50E+03	1.15E-04	5.76E-04	4.11E-12	1.52E-01	3.55E+00	B
Ra-226	2.60E+09	1.30E+10	3.00E-03	8.67E-01	4.33E+00	3.70E-02	7.03E-02	3.51E-01	3.50E-12	1.29E-01	4.55E-02	B
Ra-227	1.12E+12	5.58E+12	9.00E-05	1.24E+04	6.20E+04	7.26E+05	1.54E-06	7.69E-06	9.64E-14	3.57E-03	5.38E-01	B
Re-186	4.40E+13	1.75E+14	6.00E-01	7.34E+01	2.91E+02	6.90E+03	6.38E-03	2.53E-02	5.72E-14	2.12E-03	1.00E+01	B
Re-188	2.30E+11	1.15E+12	4.00E-01	5.76E-01	2.88E+00	3.60E+04	6.40E-06	3.20E-05	1.35E-13	4.98E-03	1.55E-01	B
Rh-105	2.71E+14	2.71E+14	8.00E-01	3.38E+02	3.38E+02	3.10E+04	8.73E-03	8.73E-03	3.69E-14	1.37E-03	1.00E+01	B
Rn-220	2.99E+12	9.93E+12	9.00E-05	3.32E+04	1.10E+05	3.41E+07	8.76E-08	2.91E-07	1.01E-12	3.73E-02	1.00E+01	B
Rn-222	2.78E+09	1.39E+10	4.00E-03	6.95E-01	3.47E+00	5.70E+03	4.87E-07	2.44E-06	4.75E-12	1.76E-01	6.59E-02	B
Sb-122	1.10E+11	5.50E+11	4.00E-01	2.75E-01	1.38E+00	1.50E+04	7.33E-06	3.67E-05	1.61E-13	5.97E-03	8.88E-02	B
Sb-124	2.20E+09	1.10E+10	6.00E-01	3.67E-03	1.84E-02	6.50E+02	3.39E-06	1.70E-05	3.58E-13	1.33E-02	3.95E-03	A
Sc-46	3.27E+09	1.64E+10	5.00E-01	6.54E-03	3.27E-02	1.30E+03	2.52E-06	1.26E-05	3.40E-13	1.26E-02	5.56E-03	A
Sc-47	2.30E+14	2.30E+14	7.00E-01	3.29E+02	3.29E+02	3.10E+04	7.42E-03	7.42E-03	4.35E-14	1.61E-03	1.00E+01	B
Sc-48	1.42E+09	7.10E+09	3.00E-01	4.73E-03	2.37E-02	5.50E+04	2.58E-08	1.29E-07	5.73E-13	2.12E-02	4.06E-03	A
Se-75	4.08E+13	1.55E+14	3.00E+00	1.36E+01	5.16E+01	5.40E+02	7.55E-02	2.87E-01	6.46E-14	2.39E-03	1.00E+01	B
Si-32	9.89E+12	4.94E+13	5.00E-01	1.98E+01	9.89E+01	3.90E+00	2.54E+00	1.27E+01	1.10E-14	4.07E-04	5.44E-01	B
Sm-153	7.09E+13	1.87E+14	6.00E-01	1.18E+02	3.11E+02	1.60E+04	4.43E-03	1.17E-02	5.35E-14	1.98E-03	1.00E+01	B
Sr-89	9.06E+12	4.53E+13	6.00E-01	1.51E+01	7.55E+01	1.10E+03	8.24E-03	4.12E-02	9.37E-14	3.47E-03	4.24E+00	B
Sr-90	7.98E+11	3.99E+12	3.00E-01	2.66E+00	1.33E+01	5.10E+00	1.57E-01	7.83E-01	1.81E-13	6.69E-03	7.22E-01	B
Tb-161	2.61E+14	2.61E+14	7.00E-01	3.73E+02	3.73E+02	4.32E+03	6.04E-02	6.04E-02	3.83E-14	1.42E-03	1.00E+01	B
Tc-99m	7.38E+11	3.69E+12	4.00E+00	1.85E-01	9.23E-01	1.90E+05	3.89E-06	1.94E-05	2.29E-14	8.46E-04	8.45E-02	A
Tc-101	7.71E+13	7.71E+13	2.00E-02	3.86E+03	3.86E+03	4.81E+06	1.60E-05	1.60E-05	1.30E-13	4.80E-03	1.00E+01	B
Te-127	2.72E+14	2.72E+14	7.00E-01	3.89E+02	3.89E+02	9.80E+04	2.78E-03	2.78E-03	3.68E-14	1.36E-03	1.00E+01	B
Te-129	4.79E+11	2.39E+12	6.00E-01	7.98E-01	3.99E+00	7.70E+05	6.21E-07	3.11E-06	9.71E-14	3.59E-03	2.32E-01	B
Te-129m	4.17E+11	2.09E+12	4.00E-01	1.04E+00	5.22E+00	1.10E+03	3.79E-04	1.90E-03	1.47E-13	5.42E-03	3.06E-01	B
Te-131	3.43E+10	1.71E+11	2.00E-02	1.71E+00	8.56E+00	2.11E+06	1.62E-08	8.12E-08	1.81E-13	6.71E-03	3.11E-02	B
Te-131m	5.66E+09	2.83E+10	5.00E-01	1.13E-02	5.66E-02	2.93E+04	1.93E-07	9.66E-07	4.44E-13	1.64E-02	1.26E-02	A
Th-227	5.41E+11	2.70E+12	5.00E-03	1.08E+02	5.41E+02	1.10E+03	4.91E-04	2.46E-03	9.76E-13	3.61E-02	2.64E+00	B
Th-228	2.20E+09	1.10E+10	1.00E-03	2.20E+00	1.10E+01	3.00E+01	7.34E-05	3.67E-04	5.50E-12	2.04E-01	6.06E-02	B
Tl-201	4.51E+14	4.51E+14	4.00E+00	1.13E+02	1.13E+02	7.90E+03	5.70E-02	5.70E-02	2.22E-14	8.21E-04	1.00E+01	B
Tl-202	3.17E+12	1.58E+13	2.00E+00	1.58E+00	7.91E+00	2.00E+03	1.58E-03	7.91E-03	7.84E-14	2.90E-03	1.24E+00	B
Tl-204	2.62E+14	2.62E+14	7.00E-01	3.74E+02	3.74E+02	1.70E+01	1.54E+01	1.54E+01	3.82E-14	1.41E-03	1.00E+01	B
Tm-168	1.19E+10	5.94E+10	2.00E-02	5.94E-01	2.97E+00	3.07E+02	3.87E-05	1.93E-04	2.13E-13	7.87E-03	1.26E-02	B
Tm-170	1.88E+14	1.88E+14	6.00E-01	3.13E+02	3.13E+02	2.20E+02	8.54E-01	8.54E-01	5.32E-14	1.97E-03	1.00E+01	B
W-187	9.14E+10	4.57E+11	6.00E-01	1.52E-01	7.62E-01	2.60E+04	3.52E-06	1.76E-05	1.20E-13	4.43E-03	5.48E-02	A
W-188	2.54E+11	1.27E+12	3.00E-01	8.47E-01	4.23E+00	3.70E+02	6.87E-04	3.43E-03	1.51E-13	5.59E-03	1.92E-01	B
Y-90	1.11E+12	5.57E+12	3.00E-01	3.71E+00	1.86E+01	2.00E+04	5.57E-05	2.78E-04	1.50E-13	5.53E-03	8.32E-01	B
Yb-169	1.31E+14	1.31E+14	1.00E+00	1.31E+02	1.31E+02	8.90E+02	1.47E-01	1.47E-01	7.65E-14	2.83E-03	1.00E+01	B
Yb-175	3.67E+14	3.67E+14	9.00E-01	4.08E+02	4.08E+02	6.60E+03	5.57E-02	5.57E-02	2.72E-14	1.01E-03	1.00E+01	B
Yb-177	2.90E+10	1.45E+11	2.00E-02	1.45E+00	7.26E+00	3.41E+05	8.51E-08	4.26E-07	1.01E-13	3.74E-03	1.47E-02	B
Zn-65	9.04E+09	4.52E+10	2.00E+00	4.52E-03	2.26E-02	3.00E+02	3.01E-05	1.51E-04	9.43E-14	3.49E-03	4.26E-03	A

Contents Type 2 - CT-2 - Solid in light tungsten insert

1	2	3	4	5	6	7	8	9	10	11	12	13
Nuclide	Package Limits		A2	# A2s		Spec Ac	Mass		Heat gen		Heat output	Package Type
	non-exclusive use Bq	exclusive use Bq	TBq	non-exclusive use	exclusive use	TBq/g	non-exclusive use g	exclusive use g	W/Bq	W/Ci	W	A or B
Zr-95	2.17E+10	1.08E+11	8.00E-01	2.71E-02	1.36E-01	7.90E+02	2.75E-05	1.37E-04	1.76E-13	6.52E-03	1.91E-02	A

Notes

Column

1. Identifies nuclide
2. Package activity limit for this Contents Type shipped under non-exclusive use
3. Package activity limit for this Contents Type shipped under exclusive use
4. A2 from 10CFR71
5. # of A2's of nuclide at package activity limit under non-exclusive use provisions
6. # of A2's of nuclide at package activity limit under exclusive use provisions
7. Specific activity from 10CFR71
8. Mass of nuclide at package activity limit non-exclusive use provisions
9. Mass of nuclide at package activity limit exclusive use provisions
10. Heat generation rate of nuclide - from Microshield in metric units
11. Heat generation rate of nuclide converted to W/Ci
12. Maximum heat output of nuclide at package activity limit under Exclusive use
13. Package Type [A or B] based on individual nuclide limit

Table 1-13 CT-3 – Solid in steel insert (LS-50x103-SS) #3986 – Activity Limits

Contents Type 3 - CT-3 - Solid in steel insert

1	2	3	4	5	6	7	8	9	10
Nuclide	Max TBq	Activity Ci	A2 TBq	# A2s	Spec Ac TBq/g	Mass g	Heat gen W/Ci	Heat output W	PackageType A or B
Ac-225	2.08E-02	5.61E-01	6.00E-03	3.46	2.10E+03	9.89E-06	3.46E-02	1.94E-02	B
Ac-227	5.40E-02	1.46E+00	9.00E-05	599.72	2.70E+00	2.00E-02	4.72E-04	6.89E-04	B
Ac-228	1.41E-03	3.81E-02	5.00E-01	0.00	8.40E+04	1.68E-08	8.04E-03	3.06E-04	A
Am-241	1.13E+01	3.05E+02	1.00E-03	11276.02	1.30E-01	8.67E+01	3.28E-02	1.00E+01	B
As-77	2.85E+00	7.71E+01	7.00E-01	4.08	3.90E+04	7.32E-05	1.41E-03	1.08E-01	B
Au-198	7.61E-02	2.06E+00	6.00E-01	0.13	9.00E+03	8.46E-06	4.34E-03	8.92E-03	A
Ba-131	2.31E-02	6.24E-01	2.00E+00	0.01	3.10E+03	7.45E-06	3.06E-03	1.91E-03	A
Bi-210	2.74E-02	7.41E-01	6.00E-01	0.05	4.60E+03	5.96E-06	2.31E-03	1.71E-03	A
C-14	1.28E+02	3.46E+03	3.00E+00	42.67	1.60E-01	8.00E+02	2.93E-04	1.01E+00	B
Co-60	3.68E-04	9.95E-03	4.00E-01	0.00	4.20E+01	8.77E-06	1.54E-02	1.53E-04	A
Cs-131	2.24E+03	6.05E+04	3.00E+01	74.58	3.80E+03	5.89E-01	1.65E-04	1.00E+01	B
Cs-134	1.62E-03	4.37E-02	7.00E-01	0.00	4.80E+01	3.37E-05	1.02E-02	4.44E-04	A
Cs-137	5.85E-03	1.58E-01	6.00E-01	0.01	3.20E+00	1.83E-03	1.01E-03	1.60E-04	A
Cu-67	7.67E+01	2.07E+03	7.00E-01	109.51	2.80E+04	2.74E-03	1.61E-03	3.33E+00	B
Hg-203	6.03E+01	1.63E+03	1.00E+00	60.26	5.10E+02	1.18E-01	1.99E-03	3.24E+00	B
Ho-166	4.46E-02	1.21E+00	4.00E-01	0.11	2.60E+04	1.72E-06	4.29E-03	5.18E-03	A
I-125	1.06E+03	2.87E+04	3.00E+00	354.17	6.40E+02	1.66E+00	3.48E-04	1.00E+01	B
I-129	5.20E-03	1.41E-01	unlimited	unlimited	6.50E-06	8.00E+02	4.68E-04	6.58E-05	B
I-131	5.03E-02	1.36E+00	7.00E-01	0.07	4.60E+03	1.09E-05	3.39E-03	4.61E-03	A
In-111	1.42E+02	3.85E+03	3.00E+00	47.45	1.50E+04	9.49E-03	2.60E-03	1.00E+01	B
Ir-192	2.10E-02	5.68E-01	6.00E-01	0.04	3.40E+02	6.18E-05	6.13E-03	3.48E-03	A
Ir-194	3.35E-02	9.05E-01	3.00E-01	0.11	3.10E+04	1.08E-06	5.35E-03	4.84E-03	A
Lu-177	3.43E+02	9.27E+03	7.00E-01	490.10	4.10E+03	8.37E-02	1.08E-03	1.00E+01	B
Mo-99	1.70E-02	4.60E-01	6.00E-01	0.03	1.80E+04	9.46E-07	3.27E-03	1.50E-03	A
Na-24	1.79E-04	4.84E-03	2.00E-01	0.00	3.20E+05	5.59E-10	2.77E-02	1.34E-04	A
Np-237	2.08E-02	5.62E-01	2.00E-03	10.40	2.60E-05	8.00E+02	2.88E-02	1.62E-02	B
P-32	2.20E-02	5.95E-01	5.00E-01	0.04	1.10E+04	2.00E-06	4.12E-03	2.45E-03	A
P-33	8.15E+02	2.20E+04	1.00E+00	814.82	5.80E+03	1.40E-01	4.54E-04	1.00E+01	B
Pb-203	5.70E-01	1.54E+01	3.00E+00	0.19	1.10E+04	5.18E-05	2.14E-03	3.29E-02	A
Pb-210	2.39E+02	6.46E+03	5.00E-02	4781.91	2.80E+00	8.54E+01	2.31E-04	1.49E+00	B
Pd-109	1.50E+01	4.06E+02	5.00E-01	30.03	7.90E+04	1.90E-04	2.14E-03	8.69E-01	B
Po-210	1.18E+01	3.18E+02	2.00E-02	589.17	1.67E+02	7.08E-02	3.14E-02	1.00E+01	B
Ra-223	5.46E-02	1.47E+00	7.00E-03	7.80	1.90E+03	2.87E-05	3.50E-02	5.16E-02	B
Ra-224	7.83E-04	2.12E-02	2.00E-02	0.04	5.90E+03	1.33E-07	3.37E-02	7.13E-04	A
Ra-226	6.81E-04	1.84E-02	3.00E-03	0.23	3.70E-02	1.84E-02	2.84E-02	5.23E-04	A
Re-186	6.93E+00	1.87E+02	6.00E-01	11.55	6.90E+03	1.00E-03	2.14E-03	4.00E-01	B
Re-188	6.02E-02	1.63E+00	4.00E-01	0.15	3.60E+04	1.67E-06	4.97E-03	8.08E-03	A
Rh-105	1.48E+01	4.00E+02	8.00E-01	18.52	3.10E+04	4.78E-04	1.37E-03	5.48E-01	B

Contents Type 3 - CT-3 - Solid in steel insert

1	2	3	4	5	6	7	8	9	10
Nuclide	Max TBq	Activity Ci	A2 TBq	# A2s	Spec Ac TBq/g	Mass g	Heat gen W/Ci	Heat output W	PackageType A or B
Se-75	1.28E+00	3.47E+01	3.00E+00	0.43	5.40E+02	2.38E-03	2.41E-03	8.34E-02	A
Sm-153	3.15E+01	8.52E+02	6.00E-01	52.55	1.60E+04	1.97E-03	1.94E-03	1.66E+00	B
Sr-89	1.06E+01	2.86E+02	6.00E-01	17.64	1.10E+03	9.62E-03	3.46E-03	9.89E-01	B
Sr-90	8.94E-01	2.42E+01	3.00E-01	2.98	5.10E+00	1.75E-01	3.46E-03	8.35E-02	B
Tb-161	1.69E+01	4.58E+02	2.00E-02	846.49	4.35E+03	3.89E-03	1.16E-03	5.31E-01	B
Th-227	1.16E-01	3.12E+00	5.00E-03	23.10	1.10E+03	1.05E-04	3.59E-02	1.12E-01	B
Th-228	5.96E-04	1.61E-02	1.00E-03	0.60	3.00E+01	1.99E-05	3.21E-02	5.18E-04	A
Tl-201	4.84E+02	1.31E+04	4.00E+00	120.90	7.90E+03	6.12E-02	7.65E-04	1.00E+01	B
W-187	8.88E-03	2.40E-01	3.00E-01	0.03	2.60E+04	3.41E-07	4.54E-03	1.09E-03	A
W-188	6.31E-02	1.71E+00	6.00E-01	0.11	3.70E+02	1.71E-04	5.98E-04	1.02E-03	A
Y-90	6.02E-03	1.63E-01	3.00E-01	0.02	2.00E+04	3.01E-07	5.54E-03	9.02E-04	A
Yb-169	5.06E+01	1.37E+03	1.00E+00	50.62	8.90E+02	5.69E-02	2.51E-03	3.43E+00	B
Yb-175	2.56E+00	6.92E+01	9.00E-01	2.84	6.60E+03	3.88E-04	1.00E-03	6.94E-02	B
Max	2.24E+03	6.05E+04		1.13E+04		8.00E+02		1.00E+01	

Notes

Column

- 1 Identifies nuclide
- 2 Package activity limit for this Contents Type
- 3 Calculated from Bq amount in Col 2
- 4 A2 from 10CFR71
- 5 # of A2's of nuclide at package activity limit
- 6 Specific activity from 10CFR71
- 7 Mass of nuclide at package activity limit
- 8 Heat generation rate of nuclide - from Microshield.
- 9 Heat output of nuclide at package activity limit
- 10 Package Type [A or B] based on individual nuclide limit

Table 1-14 CT-4 - Liquid in light tungsten insert (LS-31x73-Tu) – Activity Limits

Contents Type 4 - CT-4 – Removed, not used/approved

Table 1-15 CT-5 – Liquid in steel insert (LS-50x103-SS) – Activity Limits

Contents Type 5 - CT-5 – Removed, not used/approved

Table 1-16 CT-6 – Gas in light tungsten insert (LS-31x73-Tu) #3983 – Activity Limits

Contents Type 6 - CT-6 - Gas in light tungsten insert

1	2	3	4	5	6	7	7a	8	9	10
Nuclide	Max	Activity	A2	# A2s	Spec Ac	Mass	Volume	Heat gen	Heat output	Package Type
	TBq	Ci	TBq		TBq/g	g	cc	W/Ci	W	A or B
Kr-79	2.00E-01	5.41E+00	2.00E-02	10.01	9.24E+04	2.17E-06	5.87E-04	167E-03	9.02E-03	B
Xe-133	3.45E+02	9.33E+03	100E+01	34.51	6.90E+03	5.00E-02	8.66E+00	107E-03	100E+01	B
Max	3.45E+02	9.33E+03		3.45E+01		5.00E-02			100E+01	
Notes										
	Column									
	1	Identifies nuclide								
	2	Package activity limit for this Contents Type - from Col 17								
	3	Calculated from Bq amount in Col 2								
	4	A2 from 10CFR71								
	5	# of A2's of nuclide at package activity limit								
	6	Specific activity from 10CFR71								
	7	Mass of nuclide at package activity limit								
	7a	Volume of nuclide at package activity limit								
	8	Heat generation rate of nuclide - from Microshield.								
	9	Heat output of nuclide at package activity limit								
	10	Package Type [A or B] based on individual nuclide limit								

Table 1-17 CT-7 – Fissile solid in Normal Form in steel insert (LS-50x103-SS) #3986 – Activity Limits

Contents Type 7 - CT-7 - Fissile solid in steel insert

1	2	3	4	5	6	7	8	9	10
Nuclide	Max	Activity	A2	# A2s	Spec Ac	Mass	Heat gen	Heat output	PackageType
	TBq	Ci	TBq		TBq/g	g	W/Ci	W	A or B
Pu-238	1.14E+01	3.07E+02	1.00E-03	11354.22	6.30E-01	1.80E+01	3.26E-02	1.00E+01	B
Pu-239	1.84E+00	4.97E+01	1.00E-03	1840.00	2.30E-03	8.00E+02	3.06E-02	1.52E+00	B
Pu-240	6.72E+00	1.82E+02	1.00E-03	6720.00	8.40E-03	8.00E+02	3.06E-02	5.56E+00	B
Pu-241	3.04E+03	8.22E+04	6.00E-02	50666.67	3.80E+00	8.00E+02	3.10E-05	2.55E+00	B
U-235	6.40E-05	1.73E-03	unlimited	unlimited	8.00E-08	8.00E+02	2.71E-02	4.69E-05	B
Max	3.04E+03	8.22E+04		5.07E+04		8.00E+02		1.00E+01	

Notes

Column

- 1 Identifies nuclide
- 2 Package activity limit for this Contents Type
- 3 Calculated from Bq amount in Col 2
- 4 A2 from 10CFR71
- 5 # of A2's of nuclide at package activity limit
- 6 Specific activity from 10CFR71
- 7 Mass of nuclide at package activity limit
- 8 Heat generation rate of nuclide - from Microshield.
- 9 Heat output of nuclide at package activity limit
- 10 Package Type [A or B] based on individual nuclide limit

Table 1-18 CT-8 – Fissile solid in Special Form in steel insert (LS-50x103-SS) #3986 – Activity Limits

Contents Type 7 - CT-7 - Fissile solid in steel insert

1	2	3	4	5	6	7	8	9	10
Nuclide	Max TBq	Activity Ci	A2 TBq	# A2s	Spec Ac TBq/g	Mass g	Heat gen W/Ci	Heat output W	PackageType A or B
Pu-238	1.14E+01	3.07E+02	1.00E-03	11354.22	6.30E-01	1.80E+01	3.26E-02	1.00E+01	B
Pu-239	1.84E+00	4.97E+01	1.00E-03	1840.00	2.30E-03	8.00E+02	3.06E-02	1.52E+00	B
Pu-240	6.72E+00	1.82E+02	1.00E-03	6720.00	8.40E-03	8.00E+02	3.06E-02	5.56E+00	B
Pu-241	3.04E+03	8.22E+04	6.00E-02	50666.67	3.80E+00	8.00E+02	3.10E-05	2.55E+00	B
U-235	6.40E-05	1.73E-03	unlimited	unlimited	8.00E-08	8.00E+02	2.71E-02	4.69E-05	B
Max	3.04E+03	8.22E+04		5.07E+04		8.00E+02		1.00E+01	

Notes

Column

- 1 Identifies nuclide
- 2 Package activity limit for this Contents Type
- 3 Calculated from Bq amount in Col 2
- 4 A2 from 10CFR71
- 5 # of A2's of nuclide at package activity limit
- 6 Specific activity from 10CFR71
- 7 Mass of nuclide at package activity limit
- 8 Heat generation rate of nuclide - from Microshield.
- 9 Heat output of nuclide at package activity limit
- 10 Package Type [A or B] based on individual nuclide limit

1.2.3 Special Requirements for Plutonium

The 10 CFR 71 [1.2] regulatory limit for plutonium in liquid form of 0.74 TBq (20Ci) of plutonium is met, as the contents as specified in Section 1.2.2 do not include liquids.

1.2.4 Operational Features

The package has no complex operational features. All the operational features of the package are given in the General Arrangement drawing 0C-6041 (Section 1.3.3) and the operational instructions are presented in Section 7.

[REDACTED]

- [REDACTED]

- [REDACTED]

1.3 Appendix

1.3.1 References

- [1.1] NUREG-1609, Standard Review Plan for Transportation Packages for Radioactive Material, 1999
- [1.2] Title 10, Code of Federal Regulations, Part 71, Office of the Federal Register, Washington, DC, 2009
- [1.3] Regulatory Guide 7.9, Standard Format And Content Of Part 71 Applications For Approval Of Packages For Radioactive Material
- [1.4] Title 49, Code of Federal Regulations, Part 171, Office of the Federal Register, Washington, DC, 2009
- [1.5] IAEA Specific Safety Requirements, SSR-6 (Rev. 1), Regulations for the Safe Transport of Radioactive Material, 2018 Edition
- [1.6] Croft, QAG 009, Categorisation for Quality Categories.
- [1.7] TRANSSC, "Ageing Guide for Transport Packages, TTEG-PPA_WG-AG_001 (Rev. P)," 2020
- [1.8] IAEA Specific Safety Guide, SSG-66, Format and Content of the Package Design Safety Report for the Transport of Radioactive Material, 2022.
- [1.9] NRC General Form submission on: 02/03/2026 at 09.09 AM. It is being tracked as submission ID# 51538.
- [1.10] CERTIFICATE OF COMPLIANCE FOR RADIOACTIVE MATERIAL PACKAGES: USA/9337/B(U)-96 Revision Number 6.

1.3.2 Calculation Model Drawings

The drawings listed below and provided in this section show the details used for setting up the calculation models for stress FEA, thermal FEA and shielding calculations (Monte Carlo and Microshield).

These drawings specify nominal dimensions with particular reference to key features (such as gaps for shielding calculations).

These drawings also specify the materials: details of the materials are given in Section 2.

Drawing No.	Title
0C-6049	Safkeg-LS Construction
1C-6097	CV LS Lid Construction



1C-6099	CV LS Body Construction
---------	-------------------------

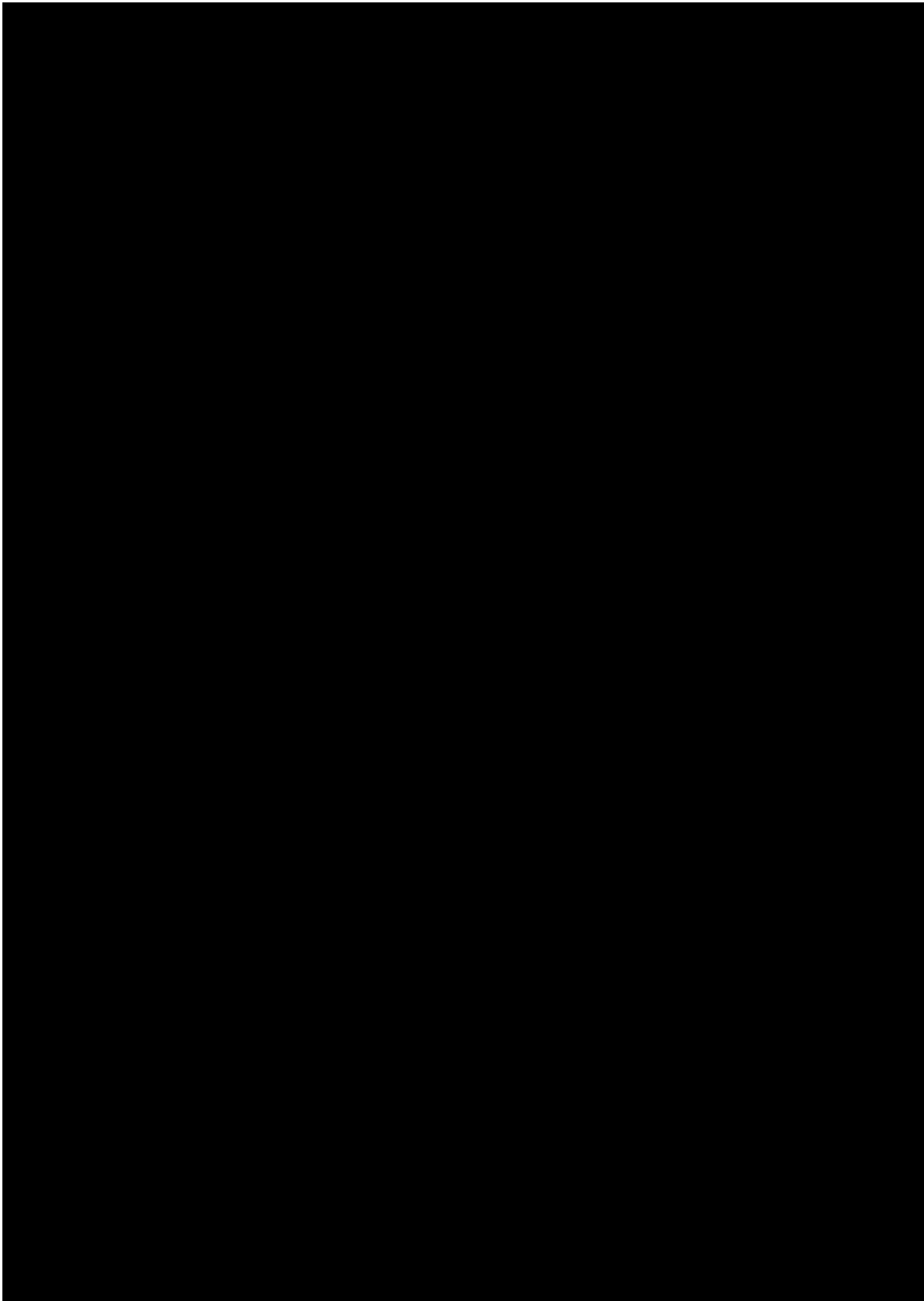

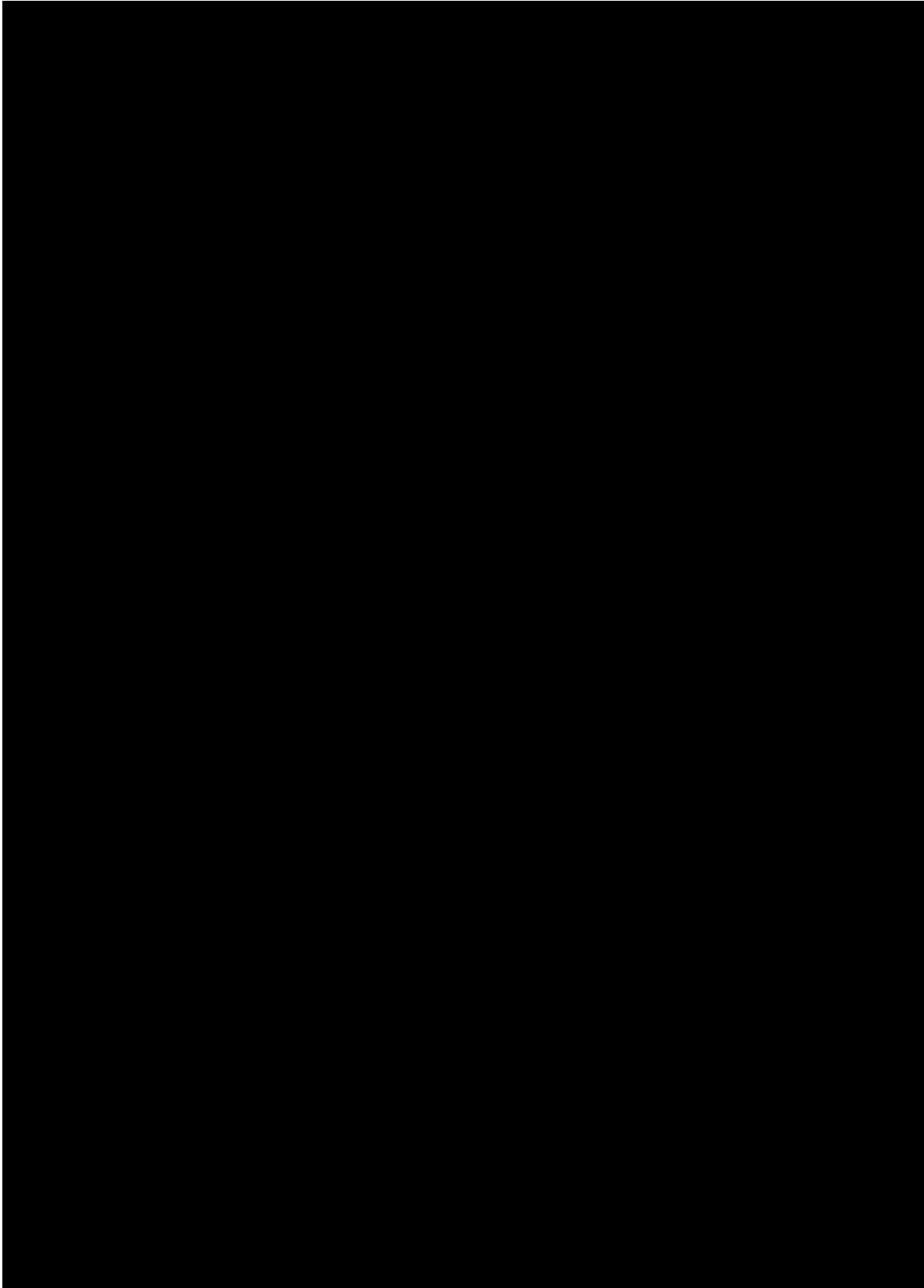

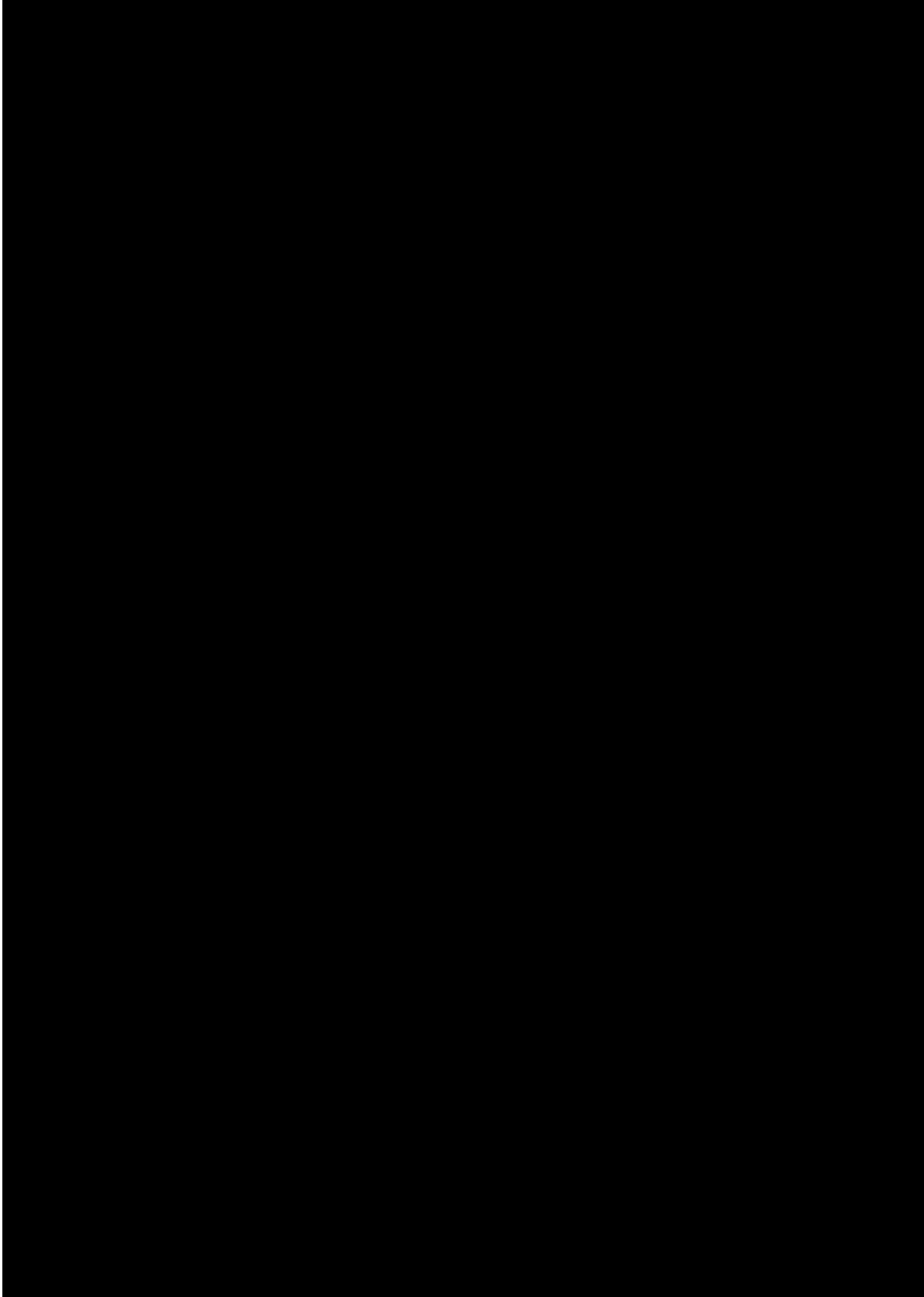

1.3.3 Licensing Drawings

The package is defined by the drawings listed below for which the revision status is given in Section 0.4. The drawings are appended to this section.

The drawings specify dimensions, fasteners, welding requirements, non-destructive examination requirements, O-ring specifications, method of O-ring retention, and closure surface requirements.

The drawings also specify the materials: details of the materials are given in Section 2.

Drawing No.	Title
1C-6040	Cover sheet for Safkeg-LS design no. 3979A (licensing drawing)
0C-6041	Safkeg-LS design no. 3979A (licensing drawing)
0C-6042	Keg design no. 3979 (licensing drawing)
0C-6043	Cork set for Safkeg-LS (licensing drawing)
1C-6044	CV design no. 3980 (assy a) (licensing drawing)
1C-6045	CV lid (assy a) (licensing drawing)
1C-6046	CV body (assy a) (licensing drawing)
2C-6171	LS-12x65-Tu insert design no. 3984 (licensing drawing)
2C-6172	LS-31x73-Tu insert design no. 3983 (licensing drawing)
2C-6175	LS-50x103-SS insert design no. 3986 (licensing drawing)
1C-9012	Containment vessel design #3980 (assy b) (licensing drawing) Machined lead components
1C-9013	Containment vessel lid (assy b) (licensing drawing) Machined lead component
1C-9014	Containment vessel body (assy b) (licensing drawing) Machined lead component

1.3.4 Supporting Documents

Document Reference	Title
PCS 036	Package Contents Specification for Safkeg-LS - Package Design No 3979A
CTR 2024/08	[REDACTED]



CTR 2024/09



2 Structural Evaluation

Contents

2	Structural Evaluation	2-1
2.1	Description of Structural Design	2-3
2.1.1	Discussion	2-3
2.1.2	Design Criteria.....	2-4
2.1.2.1	Load Combinations	2-5
2.1.2.2	Allowable Stress	2-6
2.1.2.3	Buckling	2-8
2.1.2.4	Fatigue.....	2-10
2.1.2.5	Brittle Fracture	2-10
2.1.3	Weights and Centers of Gravity [71.33]	2-10
2.1.4	Identification of Codes and Standards for Package Design.....	2-11
2.2	Materials.....	2-16
2.2.1	Material Properties and Specifications	2-16
2.2.1.1	Structural Materials	2-18
2.2.1.2	Shielding Material	2-19
2.2.1.3	Cork Packing.....	2-19
2.2.2	Chemical, Galvanic or Other Reactions [71.43(d)]	2-19
2.2.3	Effects of Radiation on Materials	2-20
2.3	Fabrication and Examination	2-24
2.3.1	Fabrication.....	2-24
2.3.2	Examination.....	2-24
2.4	General Requirements for All Packages [71.43]	2-25
2.4.1	Minimum Package Size [71.43 (a)]	2-25
2.4.2	Tamper Indicating Feature [71.43 (b)].....	2-25
2.4.3	Positive Closure [71.43 (c)].....	2-25
2.5	Lifting and Tie-Down Standards for All Packages	2-26
2.5.1	Lifting Devices [71.45 (a)]	2-26
2.5.2	Tie-Down Devices [71.45 (b)]	2-26
2.6	Normal Conditions of Transport.....	2-26
2.6.1	Heat [71.71 (c)(1)]	2-26
2.6.1.1	Summary of Pressures and Temperatures	2-26
2.6.1.2	Differential Thermal Expansion	2-27
2.6.1.3	Stress Calculations	2-27
2.6.1.4	Comparison with Allowable Stress	2-27
2.6.2	Cold [71.71 (c) (2)].....	2-29
2.6.3	Reduced External Pressure [71.71 (c) (3)].....	2-30
2.6.4	Increased External Pressure [71.71 (c) (4)]	2-32

2.6.5	Vibration [71.71 (c) (5)]	2-33
2.6.6	Water Spray [71.71 (c) (6)]	2-35
2.6.7	Free Drop [71.71 (c) (7)]	2-35
2.6.8	Corner Drop [71.71 (c) (8)]	2-41
2.6.9	Compression [71.71 (c) (9)]	2-41
2.6.10	Penetration [71.71 (c) (10)]	2-42
2.7	Hypothetical Accident Conditions [71.73]	2-42
2.7.1	Free Drop [71.73 (c)(1)]	2-42
2.7.1.1	End Drop	2-44
2.7.1.2	Side Drop	2-46
2.7.1.3	Corner Drop	2-49
2.7.1.4	Oblique Drops	2-51
2.7.1.5	Summary of Results	2-51
2.7.2	Crush [71.73 (c)(2)]	2-52
2.7.3	Puncture [71.73 (c)(3)]	2-52
2.7.4	Thermal [71.73 (c)(4)]	2-53
2.7.4.1	Summary of Pressures and Temperatures	2-53
2.7.4.2	Differential Thermal Expansion	2-54
2.7.4.3	Stress Calculations	2-54
2.7.4.4	Comparison with Allowable Stress	2-54
2.7.5	Immersion – Fissile Material [71.73 (c)(5)]	2-54
2.7.6	Immersion – All Packages [71.73 (c)(6)]	2-54
2.7.7	Deep Water Immersion Test (for Type B Packages Containing More than 105 A2) [71.61]	2-55
2.7.8	Summary of Damage	2-55
2.8	Accident Conditions for Air Transport of Plutonium [71.74]	2-56
2.9	Accident Conditions for Fissile Material Packages for Air Transport [1.55(f)]	2-56
2.10	Special Form [71.75]	2-56
2.11	Fuel Rods	2-56
2.12	Appendix	2-56
2.12.1	References	2-56
2.12.2	Supporting Documents	2-59

Introduction

This section identifies the principal structural members of the Safkeg-LS 3979A package, and the materials and fabrication methods of each are described. The ability of the package to satisfy the regulatory requirements of 10 CFR 71 [2.1], regarding Normal Conditions of Transport (NCT) and Hypothetical Accident Conditions (HAC) tests, is demonstrated in Sections 2.6 and 2.7 by Finite Element Analysis (FEA) of the containment vessel and testing of a prototype keg.

2.1 Description of Structural Design

2.1.1 Discussion

The principal structural members of the Safkeg-LS 3979A package are the 3979 keg, inner cork packing and the 3980 containment vessel. The radioactive contents are carried within product containers and inserts placed inside the containment vessel (see Section 1.2.1).

The keg is designed to absorb impacts, provide protection during handling operations and insulate the containment vessel during the HAC thermal test. The inner cork packing is designed to absorb the impact loads preventing damage to the containment vessel under HAC tests. The containment vessel is designed to provide the containment and shielding of the radioactive material and the insert is designed to provide a confinement boundary and additional shielding for the contents. A description of the structural design of each of these members is provided in the following sections.

3979 Keg

The keg comprises of a body, lid, outer cork and liner assembly as shown in drawing 0C-6042 (Section 1.3.3). The body of the keg is constructed from rolled austenitic stainless steel welded to form a cylinder. A base, top flange, skirts and rims are welded to the rolled cylinder to form the keg body. The outer cork is placed into the keg with the steel assembly liner fitting inside the cork to protect the outer cork during handling operations. The inner liner is formed from 2mm thick austenitic stainless steel.

The keg closure is facilitated by eight closure studs (occasionally referred to as bolts) screwed and glued into position on the top flange and a lock pin which is welded into position. The keg lid is a circular plate with eight holes machined for the closure bolts and one hole for the lock pin. The lid is attached to the body with eight M12 austenitic stainless steel nuts and washers. A nitrile O-ring is fitted to a groove in the flange ensuring that a weather tight seal is provided on closure of the keg. Two handles are welded to the lid to allow handling of the lid.

A fuse plug is located in the base plate of the keg body. It is present to prevent the over pressurization of the keg during the HAC thermal test. The fuse plug is austenitic stainless steel with a hole drilled through the centre which is filled with a low melting point alloy. This alloy has a melting point of $95^{\circ}\text{C} \pm 5^{\circ}\text{C}$ which once melted will allow any gases generated within the keg to vent, reducing the pressure in the keg body.

Top and Inner Cork

The inner cork fits inside the keg liner and surrounds the containment vessel. It is designed to reduce impact loads on the keg liner and the containment vessel and provide thermal insulation. The cork surrounds the side walls and the lid of the containment vessel. It varies in width from 58.5 mm to 30.5 mm on the side walls due to the variation in diameter of the containment vessel and is 85 mm thick above the lid. The cork is agglomerated and coated in a water based varnish. The cork components are shown in detail in drawing 0C-6043 (Section 1.3.3).

3980 Containment Vessel

The containment vessel consists of a body and a removable lid assembly bolted together with 8 closure bolts and sealed with an inner and outer O-ring, as shown in drawing 1C-6044 or 1C-9012 (Section 1.3.3).

The body assembly is formed from a stainless steel shell filled with antimony lead. The stainless steel shell consists of three austenitic stainless steel pieces, the inner cavity wall/flange, outer wall and base. Each piece is machined from solid austenitic stainless steel. The inner cavity wall/flange and outer wall are welded together with a circumferential groove weld which is both

visually and liquid penetrant tested. The shielding cavity is filled with lead and the base is welded into position with a circumferential groove weld which is both visually and liquid penetrant tested.

The antimony lead forms the shielding for the walls and base of the containment vessel. The antimony lead used may only contain a maximum of 0.5% impurities.

The inner cavity wall/flange and the bolted flange for the containment vessel closure form the cavity into which the radioactive contents are placed. The flange is machined with 8 closure holes into which CV closure screws (occasionally referred to as bolts) are fitted.

The containment vessel lid is comprised of two pieces a lid top and a stainless steel clad lead plug. The CV lid top is a circular plate machined from a stock billet of 304L stainless steel. Eight equally spaced counter bored holes are machined to accommodate the closure bolts. Four further holes are machined in the lid, the first accommodates the test port in order to leak test the closure system. The second is a blind hole in the centre of the lid and is fitted with a threaded insert. This allows a lifting eye to be fitted for the handling of the containment vessel. The last two allow jacking screws to be fitted which assist in the removal of the lid. Two grooves are machined onto the underside of the lid top into which the O-rings are fitted.

The lead is either cast or pre-machined from solid and fitted into a machined stainless steel casing forming the shielding plug. The plug is welded to the lid top with a circumferential weld which is liquid penetrant and visually tested.

The containment vessel lid is attached to the body with eight L43 alloy steel screws/bolts which are tightened to a torque of 10 ± 5 Nm. [REDACTED]

The design pressure for the containment vessel is 10 bar (1,000 kPa) gauge which envelopes the MNOP of 7 bar (700 kPa) gauge. The containment boundary is formed by the inner cavity wall/flange, lid and containment O-ring. This containment boundary is leak tested on manufacture, during annual maintenance and on loading.

Insert

Any one of the three inserts specified in Section 1.3.3 shall be used to provide further shielding and confinement for the contents. Two of the inserts, LS-12x65-Tu Design No 3984 and LS-31x73-Tu Design No 3983, are machined from tungsten with one, LS-50x103-SS Design No 3986, machined from stainless steel. All of the inserts consist of a body and a lid which are machined from a solid. The lid screws onto the body with an O-ring seal. The three types of inserts each have different cavity sizes and provide varying levels of shielding.

2.1.2 Design Criteria

In order to evaluate the containment design, an FEA was performed on the containment vessel under NCT and HAC using the software code Abaqus: as discussed in Vectra Report 925-3272 and report 925-3273 M2 (Section 2.12.2).

The initial load combinations used during the evaluation are discussed in Section 2.1.2.1. The resultant calculated stresses are compared against the allowable stresses presented in Section 2.1.2.2. Further evaluation is carried out to determine buckling, fatigue and brittle fracture as discussed in Sections 2.1.2.3, 2.1.2.4 and 2.1.2.5 respectively.

With regards to the model's boundary conditions the plane of symmetry was the plane $Z=0$. The boundary conditions on this plane were:

$UZ=0$

URX=0

URY=0

Where U is the displacement and UR is a rotation. As both the geometry and loading was symmetric about the plane Z=0, the use of a half-symmetry model has no effect on the results.

For the non-impact cases (NCT1-6), the flask was fixed at a single point at the centre of the bottom of the flask in the X-direction. The outer edge of the bottom of the flask was fixed in the Y-direction. These boundary conditions prevent any rigid body movement but do not affect the overall behaviour of the model. No stress concentrations were observed at these locations.

For impact cases NCT7, NCT8, HAC1 and HAC2 (drop on lid), the X and Y boundary conditions were maintained during the pre-loading steps. During the impact loading step, the Y boundary conditions were removed. Excessive movement in the Y direction and rotation about the Z axis was prevented by contact between the flask and the cork. Rigid body motion of the cork was prevented.

For impact cases NCT9, NCT10, HAC3 and HAC4 (drop on side), the X and Y boundary conditions were maintained during the pre-loading steps. During the impact loading step, the X boundary condition was removed. The Y boundary condition was changed so that it just applied to the centre of the bottom of the flask. This prevented rigid body motion in the Y direction but about allowed rotation about the Z axis. Excessive movement in the X direction was prevented by contact between the flask and the cork. Rigid body motion of the cork was prevented.

For impact cases NCT11, NCT12, HAC5 and HAC6 (drop on top corner), the X and Y boundary conditions were maintained during the pre-loading steps. During the impact loading step, the X and Y boundary conditions were removed. Excessive movement in the X and Y directions was prevented by contact between the flask and the cork. Rigid body motion of the cork was prevented.

The effectiveness of the packaging components under all the conditions of the regulatory requirements (both NCT and HAC) has been verified by physical tests. As the structural materials of the package are all austenitic stainless steel, the package is not susceptible to failure by brittle fracture. The keg, being a composite structure with the outer skin supported by the cork and the inner shell, it is not susceptible to buckling.

2.1.2.1 Load Combinations

The load combinations used in the structural evaluation of the containment vessel were developed in accordance with Regulatory Guide 7.8 [2.2]. The NCT and HAC load combinations used to determine the stresses within the containment vessel are summarized in Table 2-1 and Table 2-2.

Table 2-1 Load Combinations for NCT

Load Case ID	NCT	Initial Conditions								
		Ambient Temperature		Insolation		Decay Heat		Internal Pressure		Fabric -ation Stress
		38°C	-29°C	Max	Zero	Max	Zero	Max	Min	
NCT1	Hot environment (38°C ambient temperature)			X		X		X		X
NCT2	Cold				X		X		X	X

Load Case ID	NCT	Initial Conditions								
		Ambient Temperature		Insolation		Decay Heat		Internal Pressure		Fabric-ation Stress
		38°C	-29°C	Max	Zero	Max	Zero	Max	Min	
	environment (-40°C ambient temperature)									
NCT3	Reduced external pressure (24.5 kPa)	X		X		X		X		X
NCT4	Increased external pressure (140 kPa)		X		X		X		X	X
NCT5	Vibration (10g vertical)	X		X		X		X		X
NCT6			X		X		X		X	X
NCT7	Free drop on lid (1.2m)	X		X		X		X		X
NCT8				X		X		X		X
NCT9	Free drop on side (1.2m)	X		X		X		X		X
NCT10				X		X		X		X
NCT11	Free drop on corner (1.2 m)	X		X		X		X		X
NCT12				X		X		X		X

Table 2-2 Load Combinations for HAC

Load Case ID	HAC	Initial Conditions								
		Ambient Temperature		Insolation		Decay Heat		Internal Pressure		Fabric-ation Stress
		38°C	-29°C	Max	Zero	Max	Zero	Max	Min	
HAC1	Free drop on lid (9m)	X		X		X		X		X
HAC2			X		X		X		X	X
HAC3	Free drop on side (9m)	X		X		X		X		X
HAC4				X		X		X		X
HAC5	Free drop on corner (9m)	X		X		X		X		X
HAC6				X		X		X		X

2.1.2.2 Allowable Stress

The allowable stresses used to calculate the design margins within the containment boundary are given in Table 2-3. The allowable stresses were taken from Regulatory Guide 7.6 [2.3]. These are based on the 1977 edition of the ASME Boiler and Pressure Vessel Code [2.4]. This

guide only gives allowable stress values for primary membrane stress, primary membrane plus primary bending stress and primary plus secondary stress for both NCT and HAC loading conditions. The allowable values for bearing stress and for the bolts have been taken from ASME Section III Div 3 [2.5] as these are not given in Reg. Guide 7.6 [2.3]. Guidance for classification of stresses was taken from Table WB-3217-1 in ASME Section III Div 3 [2.5].

To demonstrate conformance with the allowable stress limits, it was necessary to determine the stress intensities at critical cross-sections of the containment vessel. Since the critical cross-section locations are load-condition dependent, several “stress evaluation sections” were defined to ensure that all critical locations were evaluated for every load condition. These stress evaluation sections are illustrated in Table 2-1. For evaluation of conditions producing a stress distribution in the vessel that is not axisymmetric, stress evaluations were performed at multiple circumferential locations.

The section stresses at each stress evaluation location were obtained using the Abaqus “stress linearization” post-processing feature (Vectra Report 925-3272/R1 (Section 2.12.2)). The stress linearization provides membrane, bending, membrane plus bending, and peak stress intensities at each section. In Abaqus, the Tresca stress is equal to the stress intensity as defined in Regulatory Guide 7.6 [2.3].

Using the critical sections from each load case, minimum design margins are calculated and reported for all bounding load combinations. The design margin (DM) is defined as follows:

$$DM = \left(\frac{\text{Allowable_Value}}{\text{Calculated_Value}} \right) - 1$$

Therefore a negative design margin indicates that the vessel has failed the assessment.

Table 2-3 Containment System Allowable Design Criteria

Stress Type	Allowable Stress Limits	
	NCT	HAC
Other Than Bolts		
Primary Membrane Stress Intensity (P_m)	S_m	Lesser of $2.4S_m$ and $0.7S_u$
Primary Local Membrane Stress Intensity (P_L)	$S_m^{(2)}$	N/A ⁽³⁾
Primary + Bending Stress Intensity (P_L or P_m+P_b)	$1.5S_m$	Lesser of $3.6S_m$ and S_u
Primary + Secondary Stress Intensity (P_L or P_m+Q)	$3.0S_m$	N/A
Average Bearing Stress	S_y	N/A
Bolts		
Average Shear Stress	$0.4S_y$	Lesser of $0.42S_u$ and $0.6S_y$
Average Stress ⁽⁴⁾	$2S_m$	Lesser of $3S_m$ and $0.7S_u$
Maximum Stress ⁽⁵⁾	$3S_m$	N/A ⁽⁶⁾

Notes:

1. Stress limits applicable for components and systems evaluated using elastic system analysis.
2. ASME B&PV code [2.5] gives an allowable of $1.5S_m$ for primary local membrane stress, P_L . However, Reg. Guide 7.6 [2.3] does not specify an allowable for this stress, so a lower allowable value of S_m has been adopted for this assessment.
3. Evaluation of secondary stress is not required for HAC.
4. The axial stress component averaged across the bolt cross-section and neglecting stress concentrations.
5. The stress due to internal pressure and gasket seating loads (e.g. bolt torque) shall not exceed one times S_m .
6. Evaluation of maximum bolt stress not required for HAC

2.1.2.3 Buckling

The containment vessel inner shell is evaluated for buckling in accordance with the requirements of ASME Code Case N-284-2 [2.6]. Capacity reduction factors are calculated in accordance with Section -1511 of ASME Code Case N-284-2 [2.6] to account for possible reductions in the capacity of the shells due to imperfections and nonlinearity in geometry and boundary conditions. Plasticity reduction factors, which account for nonlinear material properties when the product of the classical buckling stresses and capacity reduction factors exceed the proportional limit, are calculated in accordance with Section -1610 of ASME Code Case N-284-2 [2.6]. The theoretical buckling stresses of the vessel inner shell under uniform stress fields are calculated in accordance with Section -1712.1.1 of ASME Code Case N-284-2 [2.6]. The geometric parameters used in the buckling assessment are given in Table 2-4. The capacity reduction factors, plasticity reduction factors, and theoretical buckling stresses for the vessel inner shell are summarized in Table 2-5.

The allowable elastic and inelastic buckling stresses for NCT and HAC are calculated in accordance with the formulas given in Section -1713.1.1 and Section -1713.2.1 of ASME Code Case N-284-2 [2.6]. The allowable buckling stresses include factors of safety of 2.0 for NCT and 1.34 for HAC in accordance with Section -1400 of ASME Code Case N-284-2 [2.6]. Table 2-6 provides a summary of the vessel inner shell elastic and inelastic buckling stresses for NCT and

HAC. Buckling interaction ratios are calculated for the containment vessel inner shell for all NCT and HAC tests that load the shells in compression. The interaction ratios for elastic buckling and inelastic buckling are calculated using the highest values of compressive stress and shear stress from the finite element analysis solutions in accordance with the formulas given in Section -1713.1.1 and Section -1713.2.1 of ASME Code Case N-284-2 [2.6].

Table 2-4 Containment vessel shell buckling geometric parameters

Geometric Parameter	Inner Shell
Mean radius, R (mm)	33.75
Shell thickness, t (mm)	3.0
R/t	11.25
Unsupported axial length, l_ϕ (mm)	109
Unsupported circumferential length, l_θ (mm)	212.1

Table 2-5 Buckling reduction factors and theoretical buckling stresses

Calculation	Parameter	Hot ambient temperature	Cold ambient temperature
Capacity reduction factors (-1511)	$\alpha_{\phi L}$	0.2	0.3
	$\alpha_{\theta L}$	0.8	0.8
	$\alpha_{\phi\theta L}$	0.8	0.8
Plasticity reduction factors (-1610)	η_ϕ	0.1	0.1
	η_θ	0.1	0.2
	$\eta_{\phi\theta}$	0.0	0.0
Theoretical buckling values (-1712.1.1)	$\sigma_{\phi eL}$	10003 MPa	10702 MPa
	$\sigma_{\theta eL} = \sigma_{reL}$	1574 MPa	1684 MPa
	$\sigma_{\theta eL} = \sigma_{heL}$	1492 MPa	1596 MPa
	$\sigma_{\phi\theta eL}$	3804 MPa	4070 MPa

Table 2-6 Shell allowable buckling stresses

Buckling Regime	Stress Type	Allowable Buckling Stress (MPa)			
		Hot ambient temp.		Cold ambient temp.	
		NCT	HAC	NCT	HAC
Elastic Buckling	Axial Compression, σ_{xa}	1035	1545	1211	1807
	Hydrostatic Pressure, σ_{ha}	597	891	638	953
	Hoop Compression, σ_{ra}	630	940	674	1006
	In-plane shear, $\sigma_{\tau a}$	1522	2271	1628	2430
Inelastic Buckling	Axial Compression, σ_{xc}	66.0	98.5	86.0	128.4
	Radial external pressure, σ_{rc}	66.0	98.5	86.0	128.4

Buckling Regime	Stress Type	Allowable Buckling Stress (MPa)			
		Hot ambient temp.		Cold ambient temp.	
		NCT	HAC	NCT	HAC
	In-plane shear, σ_{Tc}	39.6	59.1	51.6	77.0

2.1.2.4 Fatigue

The fatigue analysis was carried out in accordance with section C3 in NRC Regulatory Guide 7.6 [2.3]. The fatigue analysis was performed as follows:

1. The alternating stress, S_{alt} , was calculated as one-half the maximum absolute value of S'_{12} , S'_{23} , S'_{31} for all possible stress states i and j where σ_1 , σ_2 , σ_3 are principal stresses and

$$S'_{12} = (\sigma_{1i} - \sigma_{1j}) - (\sigma_{2i} - \sigma_{2j})$$

$$S'_{23} = (\sigma_{2i} - \sigma_{2j}) - (\sigma_{3i} - \sigma_{3j})$$

$$S'_{31} = (\sigma_{3i} - \sigma_{3j}) - (\sigma_{1i} - \sigma_{1j})$$

State i is after the bolt pre-load has been applied and state j is after all the other loads have been applied. This calculation of S_{alt} is carried out in the post processor.

2. S_{alt} is multiplied by the ratio of the modulus of elasticity given on the design fatigue curve to the modulus of elasticity used in the analysis to obtain a value of stress to be used with the design fatigue curves.
3. The highest value of S_{alt} determined in step 2 is then compared with the design fatigue curves (Figure I-9.2.2) in appendix I of ASME B&PV Section III [2.5].

The number of cycles that the Safkeg LS CV will undergo is approximately 50 cycles/year for 20 years = 1000 cycles. The number of cycles was multiplied by 10 to give 10000 cycles, to give a safety margin.

2.1.2.5 Brittle Fracture

All the structural components of the package are fabricated from austenitic stainless steel which is ductile at low temperatures. According to Regulatory Guide 7.11 [2.6] austenitic stainless steel is not susceptible to brittle fracture at temperatures encountered in transport.

The HAC drop tests have been conducted at -40°C to determine if brittle fracture has any effect on the package, with compliance demonstrated if the containment vessel is undamaged and leak tight on completion of testing.

2.1.3 Weights and Centers of Gravity [71.33]

The nominal weight of the package plus the individual components and the maximum content weights are shown in Table 2-7. The maximum package gross weight is 64.8 kg. The center of gravity of the assembled package is approximately in the center of the 3979A keg.

The weights of the components in Table 2-7 are calculated maximum weights at extreme tolerance to give maximum material condition with rounding.

Table 2-7 Weights of SAFKEG 3979A

Components	Maximum Weight Allowing for Manufacturing Tolerances	
	Kg	lbs
Keg Body, Lid, Liner, Outer Cork, Nuts & Washers	34.3	75.6
Cork Packing	2.7	5.95
Keg plus inner and top corks	37	81.6
Containment vessel	22	48.5
LS SAFKEG 3979A excluding contents	59	130
Insert Plus Contents (max)	5.8	12.85
LS SAFKEG 3979A including contents	64.8	142.85

2.1.4 Identification of Codes and Standards for Package Design

The package has been designed to transport normal and special form material in quantities of greater than 3000A₂, therefore it is classified as a Category I package, as defined in Regulatory Guide 7.11 [2.6]. The standards to which the package has been designed, fabricated, tested and maintained have been selected based on the guidance provided in Regulatory Guide 7.6 [2.3] and NUREG/CR-3854 [2.8].

The package containment system was designed in accordance with the applicable requirements of the AMSE Code, Section III subsection NB [2.9]. The non-containment structural components of the package were designed in accordance with the applicable requirements of ASME Code section III, subsection NF for plate and shell type Class 2 supports [2.10].

The design criteria used to assess the containment boundary have been taken from Regulatory Guide 7.6 and the load combinations have been taken from Regulatory Guide 7.8 as discussed in section 2.1.2.1. The buckling evaluation of the containment vessel inner shell is evaluated in accordance with the requirements of ASME code case N-284-2 as discussed in section 2.1.2.3.

Table 2-8 identifies the major components of the LS package and identifies if they provide containment or fulfill the other safety functions such as gamma shielding or support. The drawings in section 1.3 identify whether the items are important to Safety (ITS), the identification was carried out using the guidance of NUREG/CR-6407. Table 2-8 also provides the applicable sections of the ASME code used to purchase materials, fabricate the package, inspect and examine the package. Table 2-9 lists if alternative specifications have been used to the ASME code.

The package containment system is fabricated in accordance with the applicable sections of Section III, Subsection NB of the ASME code as shown in Table 2-8. There are no welds in the containment boundary so there are no requirements listed. The other safety items shown in Table 2-8 have been fabricated in accordance with the applicable requirements of Section III Subsection NF for Class 2 supports in the ASME code

The lead shielding and the cork impact limiters are specialist materials for which an ASTM standard does not exist. The lead is fabricated and tested in accordance with standard industry practices. A chemical analysis of the batch used for the lead shielding is required prior to casting to ensure it satisfies the shielding requirements. Non-Destructive Test (NDT) examination of the lead is carried out after casting, or before machining from solid, using

gamma scintillation or ultrasonic examination testing techniques to ensure there are no cracks or voids.

The cork is fabricated in accordance with the vendor's standard practices and tested to the requirements of drawing 0C-6043.

Table 2-8 Applicable Codes and Standards for the Manufacture of the 3979A Package

	Component Safety Group					
	Containment		Other Safety			
Components	CV cavity wall/flange, CV Lid Top, Bolts	CV O-ring	CV lead	CV outer shell	Keg outer shell, keg skirts, keg lid, keg closure nuts	Cork
Function	Containment Boundary	Containment seal	Gamma Shielding	Positioning and support of Lead shielding	Secondary shell and closure	Impact limiters
Design Criteria	AMSE section III, Division 1, subsection NB-3000		AMSE section III, Division 1, subsection NF-3000			Section 2 of this SARP
Materials	NB-2000	Section 2 of this SARP	Section 2 of this SARP	NF-2000	NF-2000	Section 2 of this SARP
Forming, fitting and aligning	Not Applicable	Not Applicable	Not Applicable	NF-4200	NF-4200	Not Applicable
Welding	Not Applicable	Not Applicable	Not Applicable	NF-4400	NF-4400	Not Applicable
Qualification of weld procedure and personnel				NF-4300	NF-4300	
Examination of welds				NF-5000	NF-5000	
Acceptance Testing	NB-6000	Section 8 of this SARP and ANSI N14.5	Section 8 of this SARP	Section 8 of this SARP	Section 8 of this SARP	Section 8 of this SARP

Table 2-9 Alternative Requirements to the ASME Code Requirements

Component	Code Section	Code Requirement	Alternative Code Used and Justification
CV cavity wall/flange, CV Lid Top, Bolts	NB-2000	Metallic Materials shall be manufactured to an SA, SB of SFA specification.	NUREG/CR-3854 allows ASTM materials to be used. This SARP demonstrates equivalence between the materials.
	NB-2000	Requires materials to be supplied by ASME approved material supplier.	Croft approved suppliers will supply materials with certificates containing at the least information about: Heat number Material specification and grade Chemical analysis Mechanical properties including tensile strength and yield strength/proof stress
CV outer shell	NF-2000	Metallic Materials shall be manufactured to an SA, SB of SFA specification.	NUREG/CR-3854 allows ASTM materials to be used. This SARP demonstrates equivalence between the materials.
	NF-2000	Requires materials to be supplied by ASME approved material supplier.	Croft approved suppliers will supply materials with certificates containing at the least information about: Heat number Material specification and grade Chemical analysis



Component	Code Section	Code Requirement	Alternative Code Used and Justification
			Mechanical properties including tensile strength and yield strength/proof stress
	NF-5350	Liquid penetrant acceptance standards	NB-5350 has been used to accept the liquid penetrate tests. As allowed by NUREG 3019 [2.14] welding criteria can be upgraded by Category.
Keg outer shell, keg skirts, keg lid, keg closure nuts	NF-2000	Metallic Materials shall be manufactured to an SA, SB of SFA specification.	NUREG/CR-3854 allows ASTM materials to be used. This SARP demonstrates equivalence between the materials.
	NF-2000	Requires materials to be supplied by ASME approved material supplier.	Croft approved suppliers will supply materials with certificates containing at the least information about: Heat number Material specification and grade Chemical analysis Mechanical properties including tensile strength and yield strength/proof stress
	NF-5350	Liquid penetrant acceptance standards	NB-5350 has been used to accept the liquid penetrate tests. As allowed by NUREG 3019 [2.14] welding criteria can be upgraded by Category.

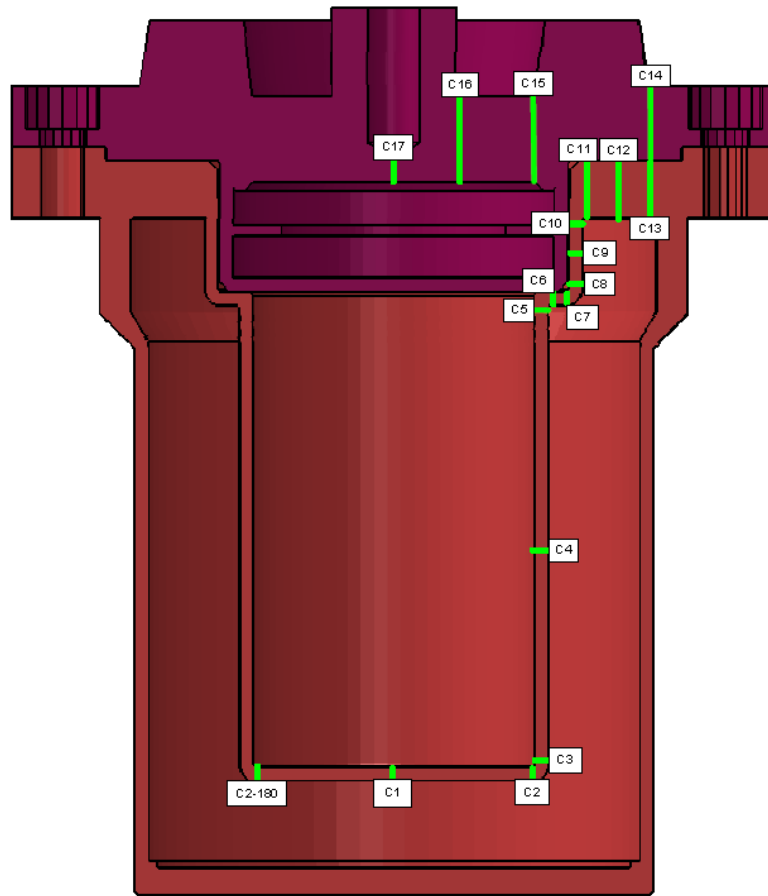

Figure 2-1 Stress Evaluation Locations

2.2 Materials

2.2.1 Material Properties and Specifications

The materials used in the construction of the package are listed in Table 2-10. The mechanical properties of the materials used in the structural evaluation of the containment vessel are presented in Sections 2.2.1.1 to 2.2.1.3.

Table 2-10 Packaging Material Specifications

Packaging Component	Material
Keg 3979	
Top and bottom rim	Stainless Steel ASTM A554 Type MT304
Top and bottom skirt	Stainless steel ASTM A240/A240M Type 304L
Keg outer shell	Stainless steel ASTM A240/A240M Type 304L
Keg top flange	Stainless Steel ASTM A240/A240M Type 304L
Keg base plate	Stainless Steel ASTM A240/A240M Type 304L
Outer cork	Agglomerated Cork

Packaging Component	Material
Keg liner	Stainless Steel ASTM A240/A240M Type 304L
Keg liner disc	Stainless Steel ASTM A240/A240M Type 304L
Keg lid	Stainless Steel ASTM A240/A240M Type 304L
Keg lid handle	Stainless Steel ASTM A240/A240M Type 304L
Keg lid seal	Nitrile 70 ± 10 IRHD
Keg closure stud	Stainless Steel ASTM A479/A479M 304L
Keg closure nut	Stainless Steel A2-70
Keg closure washers	Stainless Steel A2
Lock pin	Stainless Steel ASTM A479/A479M Type 304L
Fuse plug	Stainless steel A2
Fuse plug alloy	Low melting point alloy with melting point of 95±5°C
Inner Cork Packing	
Cork body and lid	Agglomerated Cork
Containment Vessel 3980	
Flange/cavity wall	Stainless Steel ASTM A479/A479M Type 304L
Outer wall	Stainless steel ASTM A511/A511M Type MT304L
Body shielding	Lead 4% antimony alloy
Base	Stainless Steel ASTM A240/A240M Type 304L or ASTM A479/A479M 304L
Lid shielding casing	Stainless Steel ASTM A479/A479M 304L
Lid shielding	Lead 4% antimony alloy
Lid Top	Stainless Steel ASTM A479/A479M 304L
Test point plug	Stainless Steel
Containment seal	Ethylene Propylene Rubber (EP or EPDM) ASTM D2000 M3 BA 810 A14 B13 F17 Z1 where Z1 stands for hardness of 75±5 IRHD (or Shore A)
Test seal	Ethylene Propylene Rubber (EP or EPDM) ASTM D2000 M3 BA 810 A14 B13 F17 Z1 where Z1 stands for hardness of 75±5 IRHD (or Shore A)
Test point seal	Ethylene Propylene Rubber (EP or EPDM)
Closure screws/bolts	Alloy steel ASTM A320/A320M Type L43
Jacking screw	Steel
12x65 Tu Insert	Tungsten
31x73 Tu Insert	Tungsten
50x103 SS Insert	Stainless Steel

2.2.1.1 Structural Materials

The containment vessel is fabricated entirely from stainless steel. The structural members in the main are fabricated from Type 304L stainless steel in either plate or bar form. The only exception is the containment vessel bolts which are fabricated from a high strength Grade L43 alloy bolting steel material: the justification for use of L7 material is provided in CTN 2025/01 (provided in section 2.12.2). All the insulating and shock absorbing material is fabricated from resin bonded cork.

The structural evaluation of the containment vessel was assessed under NCT using a temperature range of -40°C to 110°C . In order to carry out the stress analysis a Poisson ratio of 0.3 and a density of 8030 kg/m^3 were used for the stainless steel 304L components. A Poisson ratio of 0.3 and a density of 7860 kg/m^3 were taken for Grade L43 or L7 bolting steel.

The mechanical properties used in the structural analysis are taken from the ASME Section II Part D [2.16]. Table 2-11 provides the mechanical properties of stainless steel 304L, which makes up the majority of the structural component materials, over a range of temperatures. Table 2-12 summarizes the mechanical information for SA-320/A320 Grade L43 and



2.2.1.2 Shielding Material

The shielding is formed from lead cast within the stainless steel cladding. The lead is alloyed with 4% antimony to provide greater hardness and strength and therefore is less susceptible to lead slumping [2.19]. The mechanical properties of lead used in the structural evaluation are presented in Table 2-14.

2.2.1.3 Cork Packing

The inner and outer cork is machined from resin bonded cork. The cork may be formed from one piece or from several pieces glued with a contact adhesive.

The mechanical properties of the cork have been determined by testing. Loads were applied by a piston at a rate of 4.5 mm/minute to 45 mm thick radially constrained cork samples. The displacement of the cork was then recorded continuously at a rate of 20 readings/second. In order to cover the full range of service temperatures tests were carried out with corks at -29°C, 20°C and 100°C. The test details and results are discussed in the Serco Report SERCO/TAS/002762/01 [Section 2.12.2].

Table 2-15 presents the mechanical properties of the cork determined from testing. The test results show that cork is harder at low temperatures and softer at high temperatures. At an applied stress of 8 MPa, the cork at 100°C showed most deformation: which would indicate the containment vessel will travel a further distance into the cork before it is resisted by the same forces it would be resisted with at room temperature.

2.2.2 Chemical, Galvanic or Other Reactions [71.43(d)]

The package has been evaluated to determine all the material interactions of chemically or galvanic dissimilar materials. These interactions are identified in Table 2-16.

There is no potential for chemical, galvanic or other reactions between the components of the package which are stainless steel and cork in dry conditions, and stainless steel and encapsulated lead which is sealed and therefore dry.

2.2.3 Effects of Radiation on Materials

The contents of the package emit one or all of alpha, beta, gamma and neutron radiation. Austenitic stainless steel, lead and cork were chosen for the construction of the package because they are durable materials that are able to withstand the damaging effects from the radiation.

The EP O-ring seals fitted to the containment system are the only material on which the radiation may have an effect; however it has been shown in Section 4.1 that for the radioactive contents limited according to Section 1.2.2, the maximum dose to the containment seal is $\ll 10^4$ Gy (10^6 rad) whereas no change of physical properties of the EP containment seal is expected at radiation levels up to 10^4 Gy (10^6 rad). These seals are required to be replaced annually at maintenance (Section 8.2).

Table 2-11 Material Properties for Grade 304L Stainless Steel

Stainless Steel ASTM A240/A240m and ASTM A479/A479m Grade 304L Material Properties				Values at Different Temperatures					
				-40°C	20°C	149°C	204°C	232°C	260°C
				-40°F	68°F	300°F	400°F	450°F	500°F
				a	b	c	d	e	d
Design Stress Intensity	S _m	MN/m ²	f	115.1	115.1	115.1	108.9	105.4	102.0
		ksi	g	16.7	16.7	16.7	15.8	15.3	14.8
Yield Strength	S _y	MN/m ²	f	172.3	172.3	132.4	120.7	116.5	113.1
		ksi	h	25.0	25.0	19.2	17.5	16.9	16.4
Tensile Strength	S _u	MN/m ²	f	483	483	422	405	401	396
		ksi	i	70	70	61.2	58.7	58.1	57.5
Coefficient of Thermal Expansion (Mean)	a _m	10 ⁻⁶ m/m °C	f	14.7	15.3	16.6	17.1	17.3	17.5
		10 ⁻⁶ in/in °F	j	8.2	8.5	9.2	9.5	9.6	9.7
Thermal Conductivity	k	W/m K	f	13.9	14.9	17.0	18.0	18.5	18.9
		BTU/h ft °F	k	8.0	8.6	9.8	10.4	10.7	10.9
Modulus of Elasticity	E	GN/m ²	f	198.4	195.0	186.0	182.6	180.2	177.8
		Mpsi	l	28.8	28.3	27	26.5	26.2	25.8
Fatigue Strength @ 10 ⁶ and 10 ⁴ cycles	S _a	MN/m ²	f	195.1 and 441					
		ksi	m	28.3 and 64					

Some values are extrapolated or interpolated

- a -40°F is the lowest temperature to be considered for packaging. Data at 40°F is extrapolated where not given specifically in the ASME code. Note that the packaging is required to remain leak tight at 40°F under no loading; however, the specified structural loadings need not be considered below -20°F.
- b These data are used for calculations at normal ambient temperature
- c The temperature for this data is close to the maximum NCT temperature
- d These data are used to calculate the data at the maximum HAC
- e This data is interpolated from 400°F and 500°F
- f Calculated from the data in imperial units
- g ASME Section II (2001), Part D, Subpart 2 [2.16], Table 2A (pages 312-315)

- h ASME Section II (2001), Part D, Subpart 2 [2.16], Table Y-1 (pages 552-555)
- i ASME Section II (2001), Part D, Subpart 2 [2.16], Table U (pages 450-451)
- k ASME Section II (2001), Part D, Subpart 2 [2.16], Table TE-1 18 Cr-8 Ni (page 651 Group 3)
- l ASME Section II (2001), Part D, Subpart 2 [2.16], Table TM-1 Material Group G - Austenitic steels (page 671)
- m ASME Section III (2001), Appendix I [2.9], Table I-9.1 Line I-9.2.1 (page 4)

Table 2-12 Mechanical Properties of SA-320/A320 Grade L43 Bolting Steel

Properties				Values at Different Temperatures							
				-40°C	-30 °C	25 °C	40 °C	65 °C	100 °C	120 °C	150 °C
				-40°F	-22	77	104	149	212	248	302
				a							
Design Stress Intensity	S _m	MN/m ²	1	241	241	241	241	235	226	224	220
		ksi		34.95	34.95	34.95	34.95	34.1	32.8	32.5	31.9
Yield Strength	S _y	MN/m ²	2	723	723	723	723	704	678	671	660
		ksi		104.9	104.9	104.9	104.9	102.1	98.3	97.3	95.7
Tensile Strength	S _u	MN/m ²	3	860	860	860	860	860	860	860	860
		ksi		124.7	124.7	124.7	124.7	124.7	124.7	124.7	124.7
Coefficient of Thermal Expansion (Mean)	a _m	10 ⁻⁶ m/m °C	5	10.9	11.0	11.6	11.7	11.9	12.1	12.2	12.2
		10 ⁻⁶ in/in °F		6.06	6.1	6.4	6.5	6.6	6.7	6.8	6.8
Modulus of Elasticity	E	GN/m ²	4	195	194	191	190	189	187	186	184
		Mpsi		28.3	28.1	27.7	27.6	27.4	27.1	27.0	26.7

- 1 ASME Code, Section II, Part D, Table 4 [2.16]
- 2 In accordance with ASME code, Section II, Part D, Table 4 [2.16] general note (A), the yield strength is equal to 3 times the allowable stress value S_m
- 3 Minimum tensile strength from ASME code, Section II part D, Table 4 [2.16]
- 4 ASME Code Section II, Part D, Table TM-1, Material Group B [2.16]
- 5 ASME Code Section II, Part D, Table TE-1, Group 1, Coefficient B (mean from 70°F) [2.16]
- 6 Values in italics are calculated using linear interpolation or linear extrapolation.

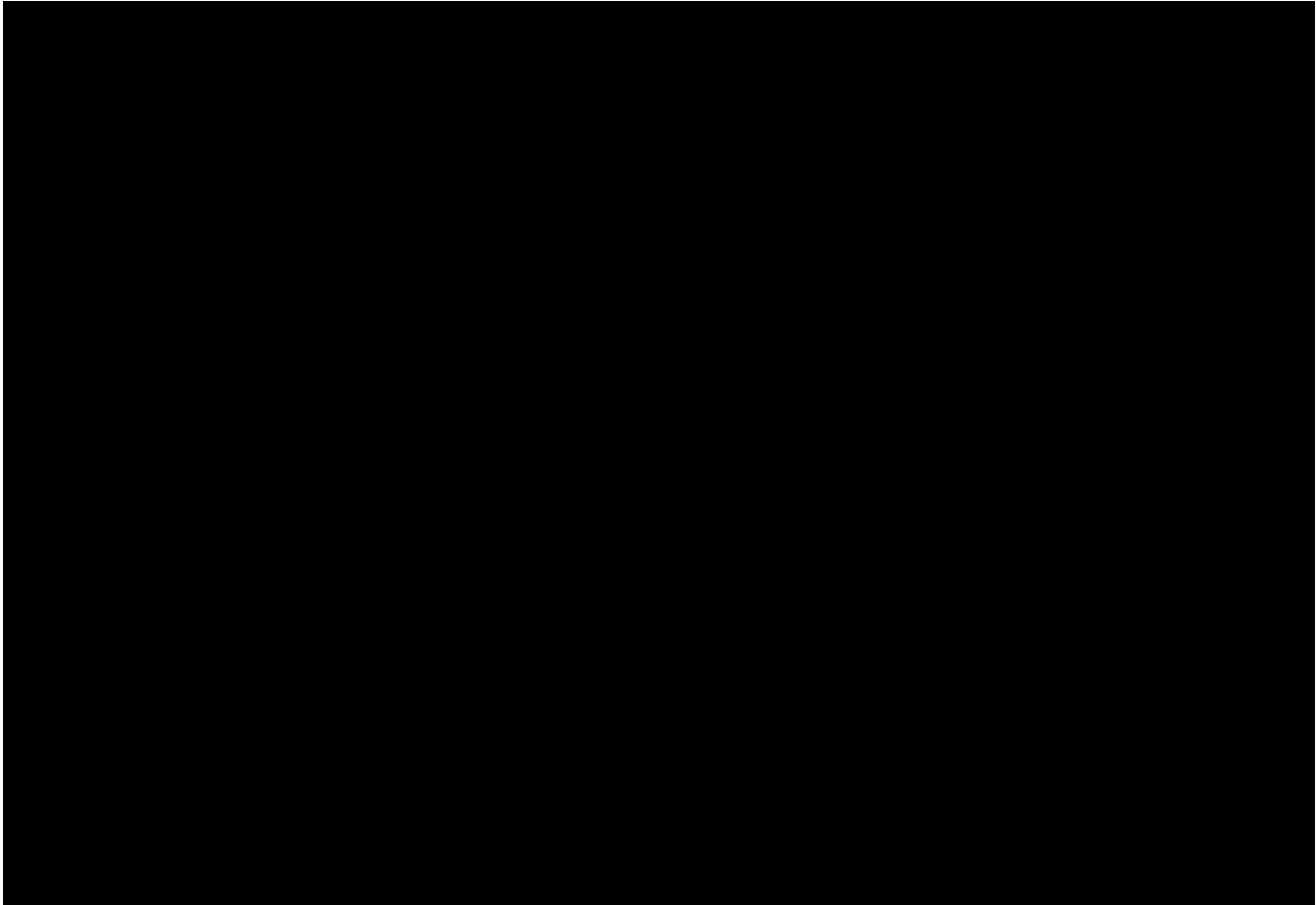

Table 2-14 Mechanical Properties of Lead Shielding

Density (kg/m ³)	Modulus of Elasticity (GPa)	Poisson's Ratio	Mean Coef. of Thermal Expansion (m/m/°C x 10 ⁻⁶)
11680	16.1	0.44	29

Table 2-15 Average compressive Modulus of Elasticity and Compressive Strength at 10% Relative Deformation for Cork at each Test Temperature

Test Temperature (°C)	Compressive Modulus of Elasticity E (MPa)	Compressive Strength at 10% relative deformation (MPa)
- 29	23.4	1.60
20	15.0	0.57
100	4.6	0.34

Table 2-16 Summary of Material Interactions

	Contents	Stainless Steel Insert	Tungsten shielding insert	Stainless steel	EP O-rings	O-ring lubricant	Lead	Cork	Cork sealant	Fuse plug alloy	Nitrile lid seal	Thread lubricant
Contents		NH	NH	H	H	H						
Stainless steel Insert				NH								
Tungsten shielding insert				NH								
Stainless steel					NH	NH	NH	H	NH	NH	NH	NH
EP O-rings						NH						
O-ring lubricant												
Lead												
Cork									NH	H		
Cork sealant										NH		NH
Fuse plug alloy												NH
Nitrile lid seal												

N = NCT, H = HAC

2.3 Fabrication and Examination

2.3.1 Fabrication

All work performed in the fabrication of the 3979A is required to be carried out under an NRC approved quality assurance program. The containment system shall be fabricated in accordance with the applicable sections of Division III Subsection NB [2.9] as shown in Table 2-8.

The other safety items are fabricated in accordance with the applicable sections of Section III subsection NF of the ASME code for plate and shell Type class 2 supports [2.10]. These components are the keg and the outer shell of the containment vessel. All welding procedures and personnel shall be qualified in accordance with AMSE section IX. Welding consumables their supply, certification, control during storage and use, shall comply with the appropriate requirements of ASME III, Division 1 subsection NF 2400. The keg shall be fabricated in accordance with drawing 0C-6042. All welding procedures and personnel shall be qualified in accordance with AMSE section IX.

The lead used shall be 4% Sb lead as specified in the drawings 1C-6045 (or 1C-9013) and 1C-6046 (or 1C-9014). It shall be either cast using standard industry practices or machined from solid. The cork shall be tested to demonstrate it meets the required specification in drawing 0C-6043 and marked with a unique identification number which will match it to the corresponding keg.

Any consumables used during manufacture such as thread inserts and O-rings shall be procured from commercial suppliers that are approved to a level commensurate with the safety functions of the consumable purchased.

2.3.2 Examination

All examinations shall be carried out under the scope of an NRC approved quality assurance program. Examinations shall be carried out on materials, components and finished assemblies throughout the manufacturing process. These tests will assure that the manufactured article meets the critical characteristics to allow the safe transport of radioactive material. All tests shall be carried out to approved procedures, with calibrated equipment. The records of the tests will be maintained with the manufacturing records for each package.

The examinations required during manufacture are described below:

Material Tests

Material examinations, from a sample of the stock material, used to fabricate the containment vessel lid top and the flange/cavity are required. These integrity tests will be an Ultrasonic straight beam test to ASME III Division 1 NB 2542 [2.9] and a liquid penetrant test to ASME III Division 1 subsection NB 2546 [2.9].

Sample O-rings shall be tested to ensure they perform satisfactory at the temperatures reached during NCT and HAC conditions. Inner and outer O-rings from each batch will be leak tested after maintaining an operating temperature of 150°C for 1000 hours. Inner and outer O-rings will also be leak tested after maintaining an operating temperature of 200°C for 24 hours.

A specimen of the lead used as the shield is required to be tested to assure that it meets the required chemical composition as defined in drawings 1C-6045 and 1C-6046.

For the cork the supplier is required to provide a Certificate of Conformance to confirm that the properties listed in drawing 0C-6043 are met.

Fabrication Tests and Examinations

Once the containment vessel lid and flange are machined, a helium leak test is required to be carried out in accordance with ANSI N14.5 [2.13]. This leak test is required to demonstrate that the leak rate of the machined items is less than or equal to 1×10^{-7} ref-cm³/s. No additional examinations are required for items which are not primary containment items.

All welds are subjected to non destructive visual and liquid penetrant examination in accordance with ASME section V [2.17]. The applicable acceptance criteria for the visual examinations are given in drawings 1C-6045 and 1C-6046. The acceptance standards for the liquid penetrant examination of the welds is in accordance with AMSE Section III Division 1 sub section NB 5350 of the ASME code.

All components and assemblies are required to be visually inspected and the dimensions measured using calibrated equipment to assure compliance with the dimensions shown on the general arrangement drawings. The weight of the finished containment vessel and fully assembled package are required to be measured to ensure the weight requirements are met.

Acceptance Tests

The completed containment vessels are required to be pressure tested to a maximum pressure of 12.5 barg which meets both the requirement of 10 CFR 71.85 (b) and ASME Section III sub section NB 6000 [2.9].

On completion of manufacture the containment vessel closures are required to be leak tested in accordance with ANSI 14.5 [2.13] to demonstrate the leak rate is less than or equal to 1×10^{-7} ref-cm³/s.

2.4 General Requirements for All Packages [71.43]

2.4.1 Minimum Package Size [71.43 (a)]

10 CFR 71.43(a) states: "The smallest overall dimension of a package may not be less than 10 cm (4 in)." The Keg 3979 has an outer diameter of 424 mm (16.69 in.) and a length of 483 mm (19.02 in.). Therefore, the smallest overall dimension of the package is not less than 10 cm (4 in), as required in 10 CFR 71.

2.4.2 Tamper Indicating Feature [71.43 (b)]

10 CFR 71.43(b) states: "The outside of a package must incorporate a feature, such as a seal, that is not readily breakable and that, while intact, would be evidence that the package has not been opened by unauthorized persons."

The tamper-proof feature of Keg 3979 is the hole provided in each closure stud which enables a wire security seal to be fitted through the studs. In addition, the keg closure is provided with a lock pin that may be fitted with a padlock. Therefore, the package can be fitted with a tamper indicating seal to provide indication that the package has not been opened.

2.4.3 Positive Closure [71.43 (c)]

10 CFR 71.43(c) states: "Each package must include a containment system securely closed by a positive fastening device that cannot be opened unintentionally or by a pressure that may arise within the package." The lid of the containment vessel is held in place using 8 screws/bolts which are screwed into the CV flange. The CV closure screws are tightened or released using

appropriate tools to the torque prescribed in the operating requirements (Section 7.1). The keg lid is attached by permanently fitted studs and secured by nuts (see Figure 1-1). Therefore, the package cannot be inadvertently opened.

The package cannot be opened unintentionally by any pressure that may arise within the package. The information presented in Section 2.6.3 shows that the containment vessels remain closed under the design pressure (which bounds the maximum internal pressure that can be generated). The keg lid will remain in place under any pressure that may arise within the package. This has been demonstrated by the thermal test reported in Section 2.7.4.

2.5 Lifting and Tie-Down Standards for All Packages

2.5.1 Lifting Devices [71.45 (a)]

The package itself has no structural devices designed for lifting the package therefore it is anticipated that the package will be man handled into position and lifted on a truck tail lift or lifted using a fork lift truck with drum clamps fitted. These methods of handling do not stress the structure of the package.

2.5.2 Tie-Down Devices [71.45 (b)]

The SAFKEG has no specifically designed tie-down devices. The normal method of securing the package during transport is expected to be by the use of dunnage, cargo nets or an equivalent system that envelope the package without being attached to it: such a system cannot stress the structure of the package. The package may be secured in either the horizontal or vertical position. Testing of both package positions during the steady state thermal test as described in CTR 2009/21 has demonstrated that either position is safe.

2.6 Normal Conditions of Transport

2.6.1 Heat [71.71 (c)(1)]

According to 10CFR 71.71 (c) (1), the package must be evaluated in an ambient temperature of 38°C, in still air and insolation. Under these conditions the maximum temperature and pressure generated have been calculated and discussed in Section 2.6.1.1. These temperatures and pressures have then been used to determine the differential thermal expansion in Section 2.6.1.2 and therefore the stresses present in the containment vessel. The calculated stresses are then used to determine if the containment vessel meets the structural design criteria.

2.6.1.1 Summary of Pressures and Temperatures

The calculated maximum temperatures in the containment vessel and keg with maximum heat load of 10W under NCT are shown in Section 3, Table 3-2. The maximum temperature for the containment vessel is 116°C. The stress calculations were carried out assuming a temperature of 110°C which is very close to the calculated maximum temperature.

The upper pressure experienced by the containment vessel is assumed to be 700 kPa gauge pressure. This value has been used in the structural evaluation.

A calculation of the actual maximum pressure expected under NCT is provided in Calculation Sheet CS 2009/08 (Section 2.12.2) – the calculated maximum pressure is 1.72 bar (172 kPa).

2.6.1.2 Differential Thermal Expansion

The finite element analysis model investigated the deformations caused within the containment vessel as a result of the differing expansion rates of the lead shielding and the stainless steel cladding. The results of the analysis included the effect of differential thermal expansion in both the radial and longitudinal directions. The results of analysis indicate that the base of the body was distorted due to the thermal expansion of the lead being greater than that of steel. The expansion of the lead also caused the internal web of the lid to bend upwards.

The 3979 keg is designed to have a 3 mm clearance between the cork and containment vessel and another 9 mm clearance between the cork and the keg lid. As the cork is free standing within the keg liner this allows movement of the top cork of up to 9 mm and hence expansion of the containment vessel of 12 mm. The radial expansion of 0.067 mm (0,003") calculated for the containment vessel is adequately covered by this gap.

The model has assumed no gap is present between the lead and the stainless steel and determined the stresses within the containment vessel boundary caused as a result of the differing thermal expansion rates. The results of the stress calculations are discussed in section 2.6.1.3.

2.6.1.3 Stress Calculations

In order to determine the effect of heat on the containment vessel a finite element analysis was carried out as documented in the Vectra Report No. 925-3272/R1 (Section 2.12.2). The model was applied with a uniform temperature of 110°C across the containment vessel and an internal gauge pressure of 700 kPa.

Stresses within the containment vessel boundary were calculated at the points shown in Figure 2-1. From these calculations the maximum stress intensities were determined and presented in Table 2-17. The maximum stress of 166 MPa occurred in the top corner of the flange and was due to the differential thermal expansion of the lead and steel. The stresses in the bolts were calculated and are presented in Table 2-18.

A buckling evaluation was also carried out using the FEA model, as described in the Vectra report No 925-3272/R1. The results of the calculation are presented in Table 2-19. The stresses used for the calculations were taken from point C4 in Figure 2-1, which is mid-way along the length of the inner shell of the containment vessel. Where one of the components was tensile in the finite element analysis it should be given a value of 0 Pa however in order to avoid zero errors it was given a very small positive value in the buckling calculation.

In order to determine the effect of repeated cycles of thermal loading on the containment vessel, fatigue calculations have been carried out in accordance with Section 2.1.2.4 and are detailed in the Vectra Report 925-3272/R1 (Section 2.12.2). The values calculated are given in Table 2-20.

2.6.1.4 Comparison with Allowable Stress

The maximum stresses calculated were compared against the allowable stresses and the design margin calculated as detailed in Section 2.1.2.2. All the design margins are greater than the design criteria of 0 as shown in Table 2-17, therefore, the containment vessel satisfies the requirements of Regulatory Guide 7.6 [2.3]. The lowest design margin calculated is 0.32 which is due to the bearing stress under the bolts.

The stresses calculated in the bolts have been compared against the allowable stresses and the design margin has been calculated as described in Section 2.1.2.2. All the design margins are

greater than 0 as shown in Table 2-18. Therefore the containment vessel bolts satisfy the requirements of Regulatory Guide 7.6 [2.3].

The buckling stresses were compared against the allowable stresses as detailed in Section 2.1.2.3. As all of the stress components were tensile in this case, the design margin is effectively infinite, hence the containment vessel satisfies the requirements of Regulatory Guide 7.6 [2.3] for buckling as shown in Table 2-19.

The fatigue evaluation is given in Table 2-20. As the value of the maximum alternating stress in the containment vessel was below the fatigue threshold, the design margin is effectively infinite. Hence the containment vessel satisfies the requirements of Regulatory Guide 7.6 [2.3] for fatigue.

Table 2-17 Containment Vessel Stress Summary under Heat Conditions

NCT Case ID	Description	Stress Type	Maximum Stress Intensity (MPa)	Stress Location	Allowable stress intensity (MPa)	Minimum Design Margin
1	Heat	P _m	71.5	C10	115	0.61
		P _m +P _b	109	C13	173	0.59
		P _m +P _b +Q	166	C11	345	1.08
		Bearing	100	Under bolts	132	0.32

Table 2-18 Containment Vessel Bolts Stress Analysis under Heat Conditions

NCT Case ID	Description	Stress Type	Maximum stress (MPa)	Allowable stress intensity (MPa)	Minimum design margin
1	Heat	Average Shear	3.32	268	79
		Average Stress	135	448	2.31
		Max Stress	149	672	3.51

Table 2-19 Containment Vessel Buckling Calculations Under Heat Conditions

NCT Case ID	Description	Stress (MPa)			Design Margin
		Axial Compression	Hoop Compression	In-plane shear	
1	Heat	0	0	0.07	4.3 x 10 ⁵

Table 2-20 Containment Vessel Fatigue Evaluation under Heat Conditions

Maximum alternating stress	Required No of cycles	Cycles to failure	Design Margin
128	10000	> 10 ¹¹	n/a

2.6.2 Cold [71.71 (c) (2)]

10CFR 71.71 (c) (2) requires that the package performance is evaluated at an ambient temperature of -40°C in still air and with no insolation. This should be considered along with no internal heat load and the minimum internal pressure.

As discussed in Section 3, at -40°C ambient temperature the package has a minimum internal pressure of 0 kPa and it is assumed the entire package temperature is -40°C . The stresses were calculated in the containment vessel using the FEA analysis described in the Vectra Report 925-3272/R1 (Section 2.12.2). It was assumed that the external pressure was 100 kPa and the internal pressure was 0 kPa absolute, so the internal gauge pressure applied to the model was -100 kPa.

The effect of temperature on the components of the containment vessel was determined with the model, as described in the Vectra Report 925-3272/R1 (Section 2.12.2). Stresses within the containment vessel boundary were calculated at the points shown in Figure 2-1. From these calculations the maximum stress intensities were determined and presented in Table 2-21. The maximum stresses calculated were compared with the allowable stresses and the design margin calculated as detailed in Section 2.1.2.2. All the design margins are greater than 0 as shown in Table 2-21 therefore the containment vessel satisfies the requirements of Regulatory Guide 7.6 [2.3].

The stresses in the bolts were calculated and are presented in Table 2-21. These stresses have been compared against the allowable stresses and the design margin has been calculated as described in Section 2.1.2.2. All the design margins are greater than 0 as shown in Table 2-22. Therefore the containment vessel bolts satisfy the requirements of Regulatory Guide 7.6 [2.3].

A buckling evaluation was also carried out using the FEA model, as described in the Vectra report No 925-3272/R1. The results of the calculation are presented in Table 2-23. The stresses used for the calculations were taken from point C4 in Figure 2-1 Stress Evaluation Locations, which is mid-way along the length of the inner shell of the containment vessel. Where one of the components was tensile in the finite element analysis it should be given a value of 0 Pa however in order to avoid zero errors it was given a very small positive value in the buckling calculation.

The buckling stresses were compared against the allowable stresses as detailed in Section 2.1.2.3. The design margin is greater than 0 hence the containment vessel satisfies the requirements of Regulatory Guide 7.6 [2.3] for buckling as shown in Table 2-23.

In order to determine the effect of repeated cycles of thermal loading on the containment vessel, fatigue calculations have been carried out in accordance with Section 2.1.2.4 and are detailed in the Vectra Report 925-3272/R1 (Section 2.12.2). The values calculated are given in Table 2-24. As the value of the maximum alternating stress in the containment vessel was below the fatigue threshold, the design margin is effectively infinite. Hence the containment vessel satisfies the requirements of Regulatory Guide 7.6 [2.3] for fatigue.

Brittle fracture has not been considered because the containment vessel and keg are fabricated from austenitic stainless steel which is ductile even at low temperatures and therefore not susceptible to brittle fracture [2.3].

Table 2-21 Containment Vessel Stress Summary under Cold Conditions

NCT Case ID	Description	Stress Type	Maximum Stress Intensity (MPa)	Stress Location	Allowable stress intensity (MPa)	Minimum Design Margin
2	Cold	P _m	50.3	C2	115	1.29
		P _m +P _b	96.1	C2	173	0.80
		P _m +P _b +Q	92.5	C4	345	2.73
		Bearing	61.9	Under bolts	172	1.78

Table 2-22 Containment Vessel Bolts Stress Analysis under Cold Conditions

NCT Case ID	Description	Stress Type	Maximum stress (MPa)	Allowable stress intensity (MPa)	Minimum design margin
2	Cold	Average Shear	1.32	289	218
		Average Stress	83.4	482	4.77
		Max Stress	149	723	3.85

Table 2-23 Containment Vessel Buckling Calculations Under Cold Conditions

NCT Case ID	Description	Stress (MPa)			Design Margin
		Axial Compression	Hoop Compression	In-plane shear	
2	Cold	20.9	37.9	0.46	1.27

Table 2-24 Containment Vessel Fatigue Evaluation under Cold Conditions

Maximum alternating stress	Required No of cycles	Cycles to failure	Design Margin
66.4	10000	> 10 ¹¹	n/a

2.6.3 Reduced External Pressure [71.71 (c) (3)]

Section 71.71 (c) (3) requires that the package is subjected to a reduced external pressure of 25 kPa absolute. According to Regulatory Guide 7.8 [2.2] the reduced external pressure should be combined with the worst case initial conditions shown in Table 2-1.

To determine the effect of the reduced external pressure with the worst case initial conditions a finite element analysis was carried out on the containment vessel as detailed in the Vectra Report 925-3272/R1 (Section 2.12.2). The analysis was carried out with an ambient temperature of 38°C in still air, with insolation and the maximum decay heat. It was assumed that under these conditions the containment vessel was at a uniform temperature of 110°C. The external pressure was 24.5 kPa with the internal pressure at 800 kPa absolute, so the internal gauge pressure applied to the model was 775.5 kPa.

The stresses were calculated at the points shown in Figure 2-1. From these calculations the maximum stress intensities were determined and presented in Table 2-24. As shown all of the design margins are greater than zero therefore satisfying the requirements of Regulatory Guide 7.6 [2.3].

A stress analysis of the containment vessel closure bolts under reduced external pressure was performed. The axial force from the finite element analysis model was extracted and divided by the bearing area of the bolt heads, to give the average bearing stress and divided by the cross sectional area of the bolts to give the average stress.

The calculated values for average shear, average stress and maximum stress of the closure bolts for the vibration load conditions are summarized in Table 2-25. The design margins are all greater than 0 therefore the bolts satisfy the requirements of Regulatory Guide 7.6 [2.3].

Buckling evaluations of the inner containment shell were carried out in accordance with the requirements of ASME Code Case N-284-2 [2.6] as detailed in Section 2.1.2.3. The stresses used for the calculations were taken from point C4 in Figure 2-1, which is mid-way along the length of the inner shell of the containment vessel. Where one of the components was tensile in the finite element analysis it should be given a value of 0 Pa however in order to avoid zero errors it was given a very small positive value in the buckling calculation.

The calculated stress from the FEA is tensile for the reduced external pressure condition. Therefore the stress is 0 MPa for axial and hoop compression, In-plane shear does have a maximum stress of 0.07. The design margin for the buckling stress was 3.1×10^5 which is greater than 0, therefore satisfying the requirements of Regulatory Guide 7.6 [2.3].

In accordance with Regulatory Guide 7.8 [2.2] regular pressurization loads should be evaluated to determine how they contribute to mechanical fatigue. The fatigue analysis was carried out in accordance with section C.3 in Regulatory Guide 7.6 [2.3]. It was assumed that the containment vessel would undergo approximately 50 cycles/year, for 20 years, which equates to 1000 cycles in its lifetime. This number was multiplied by 10 to give 10000 cycles, providing a safety margin. The maximum alternating stress was calculated as 128 MPa, this figure is below the fatigue threshold meaning that the design margin is effectively infinite with the number of cycles to failure of $>10^{11}$ far in excess of the actual number of cycles.

The results of the calculations resulting from the reduced external pressure have shown that the containment vessel satisfies the allowable design criteria. Reduced external pressure will not cause the permanent deformation of the containment vessel. It will not cause the failure of the containment vessel boundary or deformation of the bolts therefore it shall not result in any loss or dispersal of the radioactive contents.

Table 2-25 Containment Vessel Stress Summary for Changes to External Pressure

NCT Case ID	Description	Stress Type	Maximum Stress Intensity (MPa)	Stress Location	Allowable stress intensity (MPa)	Minimum Design Margin
3	Reduced External Pressure	P_m	71.7	C10	115	0.60
		P_m+P_b	108	C13	173	0.59
		P_m+P_b+Q	167	C11	345	1.07
		Bearing	100	Under bolts	132	0.32

NCT Case ID	Description	Stress Type	Maximum Stress Intensity (MPa)	Stress Location	Allowable stress intensity (MPa)	Minimum Design Margin
4	Increased External Pressure	P_m	42.0	C2	115	1.74
		P_m+P_b	81.1	C2	173	1.13
		P_m+P_b+Q	76.7	C4	345	3.50
		Bearing	64.2	Under bolts	172	1.67

Table 2-26 Containment Vessel Bolts Stress Analysis for Changes to External Pressure

NCT Case ID	Description	Stress Type	Maximum stress (MPa)	Allowable stress intensity (MPa)	Minimum design margin
3	Reduced External Pressure	Average Shear	3.29	268	80.5
		Average Stress	135	448	2.31
		Max Stress	116	672	4.75
4	Increased External Pressure	Average Shear	1.2	289	247
		Average Stress	86.9	482	4.54
		Max Stress	119	723	5.08

2.6.4 Increased External Pressure [71.71 (c) (4)]

10 CFR 71.71 (c) (4) requires that the package is subjected to an increased external pressure of 140 kPa absolute. According to Regulatory Guide 7.8 [2.2] the increase in external pressure should be combined with the worst case initial conditions shown in Table 2-1.

To determine the effect of the increased external pressure with the worst case initial conditions a finite element analysis was carried out on the containment vessel as detailed in the Vectra Report 925-3272/R1 (Section 2.12.2). The analysis was carried out with an ambient temperature of -29°C in still air, with zero insolation and zero decay heat. The external pressure was 140 kPa with the internal pressure at 800 kPa absolute, so the internal gauge pressure applied to the model was -140 kPa. A bolt pre load of 8.12 kN was applied to the bolts at the start of the analysis prior to any other load being applied.

The stresses were calculated at the points shown in Figure 2-1 Stress Evaluation Locations. From these calculations the maximum stress intensities were calculated and are presented in Table 2-25. As shown all of the design margins are greater than zero, therefore satisfying the requirements of Regulatory Guide 7.6 [2.3].

A stress analysis of the containment vessel closure bolts under increased external pressure was performed. The axial force from the finite element analysis model was extracted and divided by the bearing area of the bolt heads, to give the average bearing stress and divided by the cross sectional area of the bolts to give the average stress.

The calculated values for average shear, average stress and maximum stress of the closure bolts for the increased external pressure conditions are summarized in Table 2-26. The design margins are all greater than 0 therefore the bolts satisfy the requirements of Regulatory Guide 7.6 [2.3].

Buckling evaluations of the inner containment shell were carried out in accordance with the requirements of ASME Code Case N-284-2 [2.6] as detailed in Section 2.1.2.3. The stresses used for the calculations were taken from point C4 in Figure 2-1, which is mid-way along the length of the inner shell of the containment vessel. Where one of the components was tensile in the finite element analysis it should be given a value of 0 Pa however in order to avoid zero errors it was given a very small positive value in the buckling calculation.

The calculated stress from the FEA is tensile for the reduced external pressure condition. Therefore the stress is 0 MPa for axial and hoop compression, In-plane shear does have a maximum stress of 0.07. The design margin for the buckling stress was 3.1×10^5 which is greater than 0, therefore satisfying the requirements of Regulatory Guide 7.6 [2.3].

In accordance with Regulatory Guide 7.8 [2.2] regular pressurization loads should be evaluated to determine they contribute to mechanical fatigue. The fatigue analysis was carried out in accordance with Section 2.1.2.4. It was assumed that the containment vessel would undergo approximately 50 cycles/year, for 20 years, which equates to 1000 cycles in its lifetime. This number was multiplied by 10 to give 10000 cycles, providing a safely margin. The maximum alternating stress was calculated as 128 MPa, this figure is below the fatigue threshold meaning that the design margin is effectively infinite with the number of cycles to failure of $>10^{11}$ far in excess of the actual number of cycles.

The results of the calculations for increased external pressure have shown that the containment vessel satisfies the allowable design criteria as defined in Regulatory Guide 7.6 [2.3]. Increased external pressure will not cause the permanent deformation of the containment vessel. It will not cause the failure of the containment vessel boundary or deformation of the bolts therefore it shall not result in any loss or dispersal of the radioactive contents.

2.6.5 Vibration [71.71 (c) (5)]

10 CFR 71.71 (c) (5) requires that the package is subjected to vibration normally incident during transport. The package will be transported by all modes of transport and tied down using cargo nets or a similar system that envelope the package.

Vibration analysis has been carried out using a bounding vertical downward acceleration of 10g. Vibration loading has been applied to the containment vessel in combination with temperature and pressure loadings in accordance with Table 2-1. The stresses in the containment vessel were determined using the finite element model discussed in the appended Vectra Report 925-3272/R1 (Section 2.12.2).

Under the hot vibration conditions, a uniform temperature of 110°C and an internal gauge pressure of 700 kPa have been applied to the containment vessel. Under the cold vibration conditions an ambient temperature of -29°C is applied, along with an internal gauge pressure of -100 kPa to the containment vessel. For both tests a body force was applied to the model which was equivalent to a downward vertical acceleration of 10g. A pre load of 8.12 kN was applied to the bolts at the start of the analysis prior to any other loads being imposed. This corresponds to an applied torque of 10 Nm.

Under these vibration loading conditions the primary membrane (Pm), primary plus bending (Pm+Pb), primary plus secondary (Pm+Pb+Q) and bearing stresses have been evaluated at the locations shown on Figure 2-1 Stress Evaluation Locations. The stress distribution is given in the Vectra Report 925-3272/R1 (Section 2.12.2). The stress distribution is similar to the hot conditions stress calculation, which indicates the stresses are dominated by the thermal stress.

The maximum stress intensities calculated, along with the location of the maximum stress is summarized for each vibration load combination in Table 2-27. Each maximum stress is compared to the allowable stress intensity and a design margin given. All the design margins are greater than 0 therefore the containment vessel satisfies the requirements of Regulatory Guide 7.6 [2.3]. The lowest design margin calculated is 0.59 which is due to primary plus bending stresses on the corner of the lead shielding under hot vibration conditions.

A stress analysis of the containment vessel closure bolts under vibration load conditions was performed. The axial force from the finite element analysis model was extracted and divided by the bearing area of the bolt heads, to give the average bearing stress and divided by the cross sectional area of the bolts to give the average stress.

The calculated values for average shear, average stress and maximum stress of the closure bolts for the vibration load conditions are summarized in Table 2-28. The design margins are all greater than 0 therefore the bolts satisfy the requirements of Regulatory Guide 7.6 [2.3]. The maximum stress is 156 MPa, the maximum average stress is 135 MPa and the maximum average shear is 3.28 MPa: these values occur under the hot vibration conditions.

Buckling evaluations of the inner containment shell were carried out in accordance with the requirements of ASME Code Case N-284-2 [2.6] as detailed in Section 2.1.2.3. The stresses used for the calculations were taken from point C4 in Figure 2-1 Stress Evaluation Locations, which is mid-way along the length of the inner shell of the containment vessel. Where one of the components was tensile in the finite element analysis it should be given a value of 0, however, in order to avoid zero errors it was given a very small positive value in the buckling calculation.

The maximum calculated buckling stresses are shown in Table 2-29 along with the design margin. The maximum buckling stress of 16.3 MPa was encountered during the cold vibration condition. Table 2-29 shows that all the design margins are greater than 0 therefore the containment vessel will not buckle under an NCT free drop test and satisfies the requirements of Regulatory Guide 7.6 [2.3].

The results of the NCT Vibration structural evaluation show that the containment vessel meets all the applicable stress design criteria. The vibration loads will not result in any permanent deformation of the containment vessel or failure within the containment boundary.

Table 2-27 Containment Vessel Stress Summary for Vibration Loads

NCT Case ID	Description	Stress Type	Maximum Stress Intensity (MPa)	Stress Location	Allowable stress intensity (MPa)	Minimum Design Margin
5	Vibration (hot)	P_m	72	C10	115	0.60
		P_m+P_b	109	C13	173	0.59
		P_m+P_b+Q	168	C11	345	1.06
		Bearing	100	Under bolts	132	0.32
6	Vibration (cold)	P_m	45.8	C7	115	1.51
		P_m+P_b	79.3	C2	173	1.17
		P_m+P_b+Q	77.3	C4	345	3.46

NCT Case ID	Description	Stress Type	Maximum Stress Intensity (MPa)	Stress Location	Allowable stress intensity (MPa)	Minimum Design Margin
		Bearing	64.2	Under bolts	172	1.67

Table 2-28 Containment Vessel Bolts Stress Analysis under Vibration Load Conditions

NCT Case ID	Description	Stress Type	Maximum stress (MPa)	Allowable stress intensity (MPa)	Minimum design margin
5	Vibration (hot)	Average Shear	3.28	268	80.7
		Average Stress	135	448	2.31
		Max Stress	156	672	3.51
6	Vibration (cold)	Average Shear	1.08	289	268
		Average Stress	86.9	482	4.55
		Max Stress	119	723	5.08

Table 2-29 Containment Vessel Buckling Calculations under Vibration Load Conditions

NCT Case ID	Description	Stress (MPa)			Design Margin
		Axial Compression	Hoop Compression	In-plane shear	
5	Vibration (hot)	0	0	0.06	4.3×10^5
6	Vibration (cold)	15.0	16.3	0.42	4.26

2.6.6 Water Spray [71.71 (c) (6)]

10 CFR 71.71 (c) (6) requires that a package must be subjected to a water spray test that simulates exposure to rainfall of approximately 5 cm/hour for at least 1 hour. However the package was not subjected to a water spray test. This is because all materials both inside and out are made from materials that are water resistant. The lid of the keg is fitted with an O-ring seal for weather protection which would aid in the prevention of water entry due to water spray (rain). Therefore the water spray test would have no effect on the structural design of the package or its components and has not been performed during the regulatory tests.

2.6.7 Free Drop [71.71 (c) (7)]

10 CFR 71.71 (c) (7) requires that a package of less than 5,000 kg is subjected to a free drop test from a distance of 1.2 m onto an essentially unyielding, horizontal surface, striking in a position for which the maximum damage is expected.

The package was evaluated in three different drop orientations as shown in Figure 2-2, in all cases the centre of gravity was over the point of impact. These orientations were considered worst case because previous experience has shown that a drop on the side leads to the highest

stresses in the package. A drop on the lid or the top rim of the package may distort the lid and open the seals which would be more likely to cause a loss of containment.

The effect of a free drop test on the package was determined with a series of physical drop tests on a prototype package and a finite element analysis of the containment vessel.

The NCT free drop tests were carried out on a prototype package within the series of NCT and HAC tests, as described in the Croft Reports CTR 2009/21 and CTR 2009/27, appended in Section 2.12.2. The test package of 61.8 kg mass was dropped 1.2 meters onto a steel target with a mass of 500 kg, which was located on a thick concrete base. The NCT free drop tests were all carried out at an ambient temperature of 14°C.

In order to determine the effect of testing on the package several modifications were made to the containment vessel, cork and keg. To accommodate the wiring for the test equipment small holes of up to 25 mm were drilled through the center of the containment vessel lid, top cork and keg lid. A drain hole on the side of the keg was enlarged to allow the test equipment wiring to pass through it. Finally two cavities and threaded holes were machined into the containment vessel lid to allow the attachment of the accelerometers. The changes are discussed in more detail in the Croft Reports CTR 2009/21 and CTR 2009/27(Section 2.12.2). These changes are would not affect the structural integrity of the package or the test results: if anything they would slightly weaken the integrity causing the tests to have a greater effect on the test package than the actual package.

The total mass of the tested package was 61.72 kg which is 5% lighter than the design weight of 64.8 kg given in section 2.1.3. The design weight is greater than the tested package weight to allow for variations due to manufacturing tolerances. In order to account for the lower weight of the test package it was dropped from 10.2 m under the HAC tests, this is a 13% increase in the drop height and energy of the package at impact.

Aside from minor weight differences and the modifications discussed for testing, the prototype package was identical to the manufactured package.

The drop tests caused minor denting to the bottom and top rim of the 3979 keg. No visible damage or deformation was present on the body of the keg after each of the drop tests. This indicates there would be no significant change in the radiation level. Helium leakage testing was carried out prior to and after the entire test series. The leakage testing demonstrated the containment vessel remained leak tight throughout the test series. The containment vessel bolts did not loosen during the test series.

A detailed analysis of the stress present in the containment vessel during the free drop test was carried out using a finite element model of the containment vessel as described in Vectra Report 925-3272/R1 appended in Section 2.12.2.

The three drop orientations illustrated in Figure 2-2 were modeled under 'hot' and 'cold' conditions as required by Regulatory Guide 7.8 [2.2]. The hot conditions assumed the package experienced the maximum ambient temperature of 38°C, in still air with maximum insolation and decay heat. With these conditions it was assumed that the containment vessel was at a uniform temperature of 110°C. Along with the hot temperature it was assumed that the containment vessel had an internal pressure of 800 kPa. The external pressure was taken as 100 kPa, so the internal gauge pressure was 700 kPa

The cold conditions assumed an ambient temperature of -29°C, in still air with no insolation or decay heat. It has been assumed that the internal pressure is 0 kPa with an external pressure

of 100 kPa, so the internal gauge pressure is -100 kPa. The load combinations modeled for the NCT drop tests are outlined in Table 2-1.

A body force was applied to the model which was equivalent to those measured during the drop tests. Table 2-31 lists the g values used for each load case. The measured g values are shown in Table 2-30. A dynamic load factor (DLF) has not been applied to the model because a static analysis was performed.

For the entire NCT free drop analysis a pre load of 8.12kN was applied to the bolts at the start of the analysis, prior to any other loads being imposed. The bolts were tied to the CV body along the threaded length with the bolt heads free to slide.

Stress calculations were carried out for each free drop load combination. Stress distributions presented in Vectra Report 925-3272/R1 (Section 2.12.2) indicated that the highest stresses were in the outer part of the body resisting thermal expansion. However the drop on the lid caused distortion of the lid due to the tungsten insert impacting the bottom of the lid and the effect of the mass of the lead shielding. The drop on the side was found to cause the inner body of the containment vessel and tungsten insert to rotate clockwise.

The primary membrane (Pm), primary plus bending (Pm+Pb), primary plus secondary (Pm+Pb+Q) and bearing stresses were evaluated at the locations shown on Figure 2-1, for each of the free drop load combination identified in Table 2-1 (NCT load ids 7 – 12). The maximum stress intensities calculated along with the location of the maximum stress is given for each free drop load combination in Table 2-32. Each maximum stress is compared to the allowable stress intensity and the design margin given. All the design margins are greater than 0 therefore the containment vessel satisfies the requirements of Regulatory Guide 7.6. The lowest design margin calculated is 0.28 which is due to the bearing stress under the bolts when the package under the hot conditions is dropped on its side and on its corner. The g value applied to the model for the drop on the side of the package was a radial deceleration of 112g which is lower than the measured value of 273g. The drop on the corner had an axial deceleration of 264g and a radial deceleration of 278g applied to the model. It is considered that a corner impact would impose greater loading on the components due to the smaller impact area than the equivalent side impact. Therefore because the corner drop has higher g values applied and imposes greater loading it stands to reason that the side drop would remain acceptable if 273g had been applied to the drop on side model. It should be noted that the minimum design margins due to bearing stress under the bolts is caused by thermal stress around the bolts.

The calculated values for average shear, average stress and maximum stress of the closure bolts for each free drop condition are summarized in Table 2-33. The design margins for drop conditions are all greater than 0 therefore the bolts satisfy the requirements of Regulatory Guide 7.6 [2.3]. The maximum stress is 151 MPa and the maximum average stress is 139 MPa, both these values occur under hot conditions when the package is dropped onto the side and top corner. The maximum average shear of 8.67 MPa occurs when the package is dropped under hot conditions onto the corner.

Buckling evaluations of the inner containment shell were carried out in accordance with the requirements of ASME Code Case N-284-2 [2.6] as detailed in Section 2.1.2.3, for all the NCT free drop load combinations. The stresses used for the calculations were taken from point C4 in Figure 2-1, which is mid-way along the length of the inner shell of the containment vessel. Where one of the components was tensile in the finite element analysis it should be given a value of 0 Pa however in order to avoid zero errors it was given a very small positive value in the buckling calculation.

The maximum calculated buckling stresses are shown in Table 2-34 along with the design margin. The maximum buckling stress of 43 MPa was encountered during the drop on the side under cold conditions. Table 2-34 shows that all the design margins are greater than 0 therefore the containment vessel will not buckle under an NCT free drop test and satisfies the requirements of Regulatory Guide 7.6 [2.3].

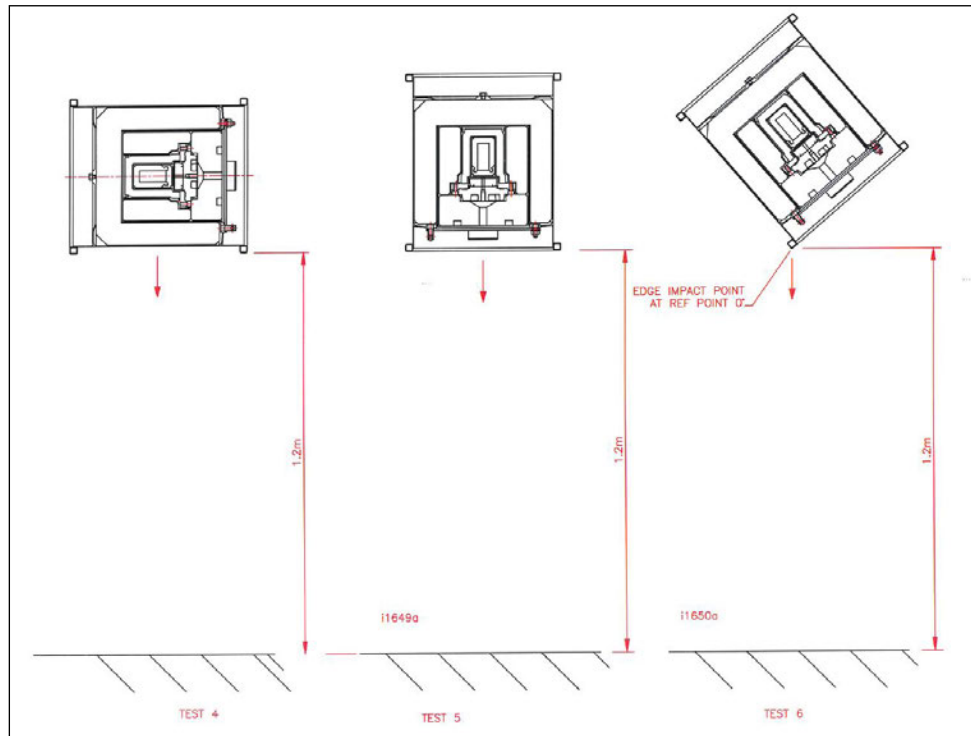

Figure 2-2 NCT Free Drop Impact Orientations

Table 2-30 Acceleration Data Recorded during Drop Tests

Test			Drop on side	Drop on lid	Drop on top rim	Drop on side	Drop on top rim	Drop on lid
Drop Height (m)			1.2	1.2	1.2	10.2	10.2	10.2
Peak Acceleration	Axial (g)	Accelerometer 1	55	113	265	298	311	449
		Accelerometer 2	69	80	205	255	388	340
	Radial (g)	Accelerometer 1	273	133	249	424	169	186
		Accelerometer 2	269	143	278	430	177	192

Table 2-31 Acceleration values applied to the FEA Analysis

Case	Description	Acceleration
NCT7	Free drop on lid from 1.2m (hot)	112g axial

Case	Description	Acceleration
NCT8	Free drop on lid from 1.2m (cold)	112g axial
NCT9	Free drop on side from 1.2m (hot)	112g radial
NCT10	Free drop on side from 1.2m (cold)	112g radial
NCT11	Free drop on corner from 1.2 m (hot)	264g axial 278g radial
NCT12	Free drop on corner from 1.2 m (cold)	264g axial 278g radial
HAC1	Free drop on lid from 10.2 m (hot)	430g axial
HAC2	Free drop on lid from 10.2 m (cold)	430g axial
HAC3	Free drop on side from 10.2 m (hot)	448g radial
HAC4	Free drop on side from 10.2 m (cold)	448g radial
HAC5	Free drop on corner from 10.2 m (hot)	388g axial 178g radial
HAC6	Free drop on corner from 10.2 m (cold)	388g axial 178g radial

Table 2-32 NCT Free Drop Stress Summary

NCT Case ID ^[1]	Description ^[2]	Stress Type	Maximum Stress Intensity (MPa)	Stress Location ^[3]	Allowable stress intensity (MPa)	Minimum Design Margin ^[4]
7	Drop on lid from 1.2m (hot)	P _m	77.7	C9	115	0.48
		P _m +P _b	110	C13	173	0.57
		P _m +P _b +Q	118	C11	345	1.93
		Bearing	101	Under bolts	132	0.32
8	Drop on lid from 1.2m (cold)	P _m	34.9	C5	115	2.29
		P _m +P _b	39.6	C2	173	3.35
		P _m +P _b +Q	65.3	C7	345	4.28
		Bearing	63.6	Under bolts	172	1.70
9	Drop on side (hot)	P _m	79.0	C9-180	115	0.45
		P _m +P _b	105	C13	173	0.64
		P _m +P _b +Q	143	C11-180	345	1.41
		Bearing	103	Under bolts	132	0.28
10	Drop on side (cold)	P _m	44.4	C8	115	1.59
		P _m +P _b	83.5	C2-180	173	1.07
		P _m +P _b +Q	67.0	C7-180	345	4.00

NCT Case ID ^[1]	Description ^[2]	Stress Type	Maximum Stress Intensity (MPa)	Stress Location ^[3]	Allowable stress intensity (MPa)	Minimum Design Margin ^[4]
		Bearing	65.3	Under bolts	172	1.64
11	Drop on corner (hot)	P _m	89.1	C9-180	115	0.29
		P _m +P _b	113	C13-180	173	0.53
		P _m +P _b +Q	136	C10-180	345	1.54
		Bearing	103	Under bolts	132	0.28
12	Drop on corner (cold)	P _m	80.3	C6-180	115	0.43
		P _m +P _b	134	C2-180	173	0.29
		P _m +P _b +Q	178	C6-180	345	0.94
		Bearing	66.0	Under bolts	172	1.61

Notes:

1. NCT case IDs are obtained from Table 2-1
2. The orientation of the drop is given in Figure 2-2
3. Stress locations are shown in Figure 2-1. Locations ending -180 are on the opposite side of the vessel to those shown in Figure 2-1, i.e. they are on the side of the vessel closest to the impact with the cork impact limiter.

Table 2-33 Containment Vessel Closure Bolts NCT Free Drop Stress Summary

NCT Case ID ^[1]	Description ^[2]	Stress Type	Maximum stress (MPa)	Allowable stress intensity (MPa)	Minimum design margin
7	Drop on lid from 1.2m (hot)	Average Shear	6.27	268	41.7
		Average Stress	137	448	2.26
		Max Stress	151	672	3.44
8	Drop on lid from 1.2m (cold)	Average Shear	3.72	289	76.8
		Average Stress	88.9	482	4.61
		Max Stress	118	723	5.12
9	Drop on side (hot)	Average Shear	4.53	268	58.1
		Average Stress	139	448	2.22
		Max Stress	151	672	3.45
10	Drop on side (cold)	Average Shear	2.22	289	129
		Average Stress	88.0	482	4.47
		Max Stress	120	723	5.05
11	Drop on corner (hot)	Average Shear	13.3	268	19.2
		Average Stress	139	448	2.21
		Max Stress	153	672	3.38

NCT Case ID ^[1]	Description ^[2]	Stress Type	Maximum stress (MPa)	Allowable stress intensity (MPa)	Minimum design margin
12	Drop on corner (cold)	Average Shear	8.67	289	32.3
		Average Stress	89.1	482	4.41
		Max Stress	123	723	4.90

Notes:

1. NCT case IDs are obtained from Table 2-1
2. The orientation of the drop is given in Figure 2-2

Table 2-34 NCT Free Drop Buckling Evaluation Summary

NCT Case ID	Description	Stress (MPa)			Design Margin
		Axial Compression	Hoop Compression	In-plane shear	
7	Drop on lid from 1.2m (hot)	0	0	0.023	2.8x10 ⁶
8	Drop on lid from 1.2m (cold)	26.1	33.7	0.06	1.55
9	Drop on side (hot)	0	0	0.09	1.9 x 10 ⁵
10	Drop on side (cold)	22.6	43.0	0.21	1
11	Drop on corner (hot)	6.11	0	0.5	9.78
12	Drop on corner (cold)	51.7	49.0	0.19	0.66

Notes:

1. NCT case IDs are obtained from Table 2-1
2. The orientation of the drop is given in Figure 2-2

2.6.8 Corner Drop [71.71 (c) (8)]

The requirement of 10 CFR 71.71(c) is that a fiberboard, wood or fissile material rectangular package not exceeding 50 kg (110 lbs) and fiberboard, wood, or fissile material cylindrical packages not exceeding 100 kg (220 lbs) must be subjected to a free drop onto each corner of the rectangular package or onto each quarter of each rim of the cylindrical package. The package must be dropped from a height of 0.3 m onto a flat, essentially unyielding surface.

The Safkeg-LS 3979A package is a robust steel shell package which only suffered minor deformation under both 1.2 m and 10.2 m drop tests: these tests demonstrated that a 0.3m drop would have no significant effect on the package.

2.6.9 Compression [71.71 (c) (9)]

According to 71.71(c) (9), the package must be subjected to a compressive load for a period of 24 hours. This load must be applied uniformly to the top and bottom of the package in the position in which the package is normally transported. The load applied must be the greater of 5 times the weight of the package or the equivalent of 13 kPa multiplied by the vertically projected area of the package.

The maximum mass of the package is 64.8 kg therefore 5 times the mass is 324 kg. The vertically projected area of the package is 0.116 m² multiplied by 13 kPa this results in a force of 1504 N which is equivalent to a stacking weight of 154 kg. Five times the mass of the package (324 kg) is the greater of the two and was used as the appropriate test weight.

The compression test was carried out on a prototype keg. The test procedure and results are documented in the Croft Report CTR 2009/21 appended in Section 2.12.2.

An empty keg body was subjected to a compressive load of 500 kg which is well in excess of the 324 kg required. The keg was weighed and dimensions taken before and after testing. On completion of the test no part of the keg showed any visually observed evidence of plastic deformation and no changes in dimensions or weight was found. These results show that the package satisfies the compression test criteria.

2.6.10 Penetration [71.71 (c) (10)]

In accordance with section 71.71 (c) (10) a 6 kg steel bar with a diameter of 3.2 cm was dropped from a height of 1m onto the side of a prototype package. The side was considered the most vulnerable area to puncture. The penetration test was carried out during the NCT test series and is described in CTR 2009/21 appended in Section 2.12.2. The test caused a dent of 8.9 mm in depth and 105 mm width in the keg skin but the skin was not punctured or torn.

A dent of 8.9 mm was the largest dent encountered during NCT test conditions, therefore this dent shall provide the basis for the allowable dents during the maintenance and package loading checks described in sections 7 and 8.

2.7 Hypothetical Accident Conditions [71.73]

Section 71.51 requires that when subjected to the HAC tests, the damage caused to the package does not lead to the loss of radioactive material exceeding a total amount of A₂ in one week, or an increase in the external radiation dose above 10 mSv/hr at 1m from the external surface of the package. In order to demonstrate compliance a prototype package was subjected to a series of HAC tests and the stresses in the containment vessel were modeled under the HAC test conditions.

The HAC tests were performed on the prototype keg after the NCT penetration and drop tests. The HAC tests were carried out sequentially in the order of puncture tests, drop tests, additional puncture test and thermal test. Therefore the keg was tested for the cumulative effects of both the NCT and HAC tests. The drop and final puncture tests were carried out with the package at -40°C to take into account any brittle failure. The containment vessel was analyzed under the most unfavorable initial conditions for each individual HAC test condition.

The results of the tests and analysis show that the package and the containment vessel satisfy the design criteria of Regulatory Guide 7.6 [2.3] when subjected to the affects of the HAC tests.

2.7.1 Free Drop [71.73 (c)(1)]

10 CFR 71.73 (c) (1) requires that a specimen undergoes a free drop through a distance of 9 m onto a flat and essentially unyielding, horizontal surface striking in a position for which the maximum damage is expected. In order to fulfill this requirement a prototype package was dropped 10.2 meters in several orientations.

The procedure, sequence of testing and results are documented in the Croft Reports CTR 2009/21 and CTR 2009/27 appended in Section 2.12.2. A series of 10.2 m drop tests were performed at the Croft Associates, Didcot Test Facility, as part of the NCT and HAC test series.

This facility has a test target consisting of a 50 mm thick non alloy structural steel plate. This plate sits at ground level on a one piece, continuously poured, cast in situ concrete block. The mass of the target is 50 tonnes.

The mass of the test package is 5% less than the maximum mass of the package; to compensate for this the test package was dropped from 10.2m which is 13% higher than the 9m specified in the regulations. As a result the energy at impact was 13% greater than required.

Regulatory Guide 7.8 suggests that the following orientations are considered, top end, top corner, side, bottom end and bottom corner. Previous tests on other Safkeg packages have shown that the highest shock is produced by the side impact, based on the assumption that the minimum measured deformation of the package produces the highest deceleration. On the basis of this evidence, and consideration of the damage mechanisms that could lead to loss of containment or failure to meet other regulatory criteria, the first orientation of the 10.2 m drop test was chosen to be a side impact (with axis horizontal). It was considered that a drop on the bottom or bottom rim of the package would cause less damage than a drop on the lid or the rim of the package. A drop on the lid or rim may distort the lid and open the seals however this would not occur with a drop on the bottom or the bottom corner. Therefore the 10.2 m drop tests were carried out in the order and orientations illustrated in Figure 2-3

The drop tests were performed with the test package cooled to -40°C . This temperature was considered the most challenging because brittle fracture is more likely at lower temperatures and the cork is also harder at lower temperatures thus providing less impact protection.

The package for the 10.2 m drop consisted of the fully assembled package with some modifications made to allow for test equipment to be fitted and data to be recorded. Several modifications were made to the containment vessel, cork and keg. To accommodate the wiring of the test equipment small holes of up to 25 mm were drilled through the center of the containment vessel lid, top cork and keg lid. A drain hole on the side of the keg was enlarged to allow the test equipment wiring to pass through it. Finally two cavities and threaded holes were machined into the containment vessel lid to allow the attachment of the accelerometers. The changes are discussed in more detail in the Croft Report CTR 2009/21 (Section 2.12.2). These changes would not affect the structural integrity of the package or the test results.

Aside from minor weight differences and modifications discussed for testing, the prototype package will be identical to the manufactured package. The test package was loaded with the 12 x 65 tungsten insert filled with 42 g (0.09 lb) of lead shot, to simulate the maximum permissible mass of contents.

Prior to the NCT and HAC test series the package and its components were measured and weighed. The containment vessel was also helium leak tested to ensure it was leak tight. On completion of the test series these tests were repeated to determine the damage sustained to the package and if the containment vessel remained leak tight.

Along with the physical tests a stress analysis of the containment vessel under HAC test conditions, was carried out, using a finite element analysis detailed in the Vectra Report 925-3272/R1 (Section 2.12.2). In accordance with Regulatory Guide 7.8 [2.2] each drop orientation was evaluated in combination with the worst case initial conditions. The load conditions used along with each drop test orientation is given in Table 2-2.

Once the load conditions had been applied a body force equivalent to the g value measured during the drop test was applied to the vessel. The g values applied to each test condition are given in Table 2-31.

The maximum stresses in the containment vessel are calculated and shown to satisfy the requirements of ASME Section III Div 3 [2.5] for bearing stress and bolt stress and satisfying Regulatory Guide 7.6 for all other stresses. In addition the containment vessel inner shell was evaluated for buckling in accordance with the requirements of ASME Code Case N-284-2 [2.6].

The results of each drop test and stress analysis are given in the following sections.

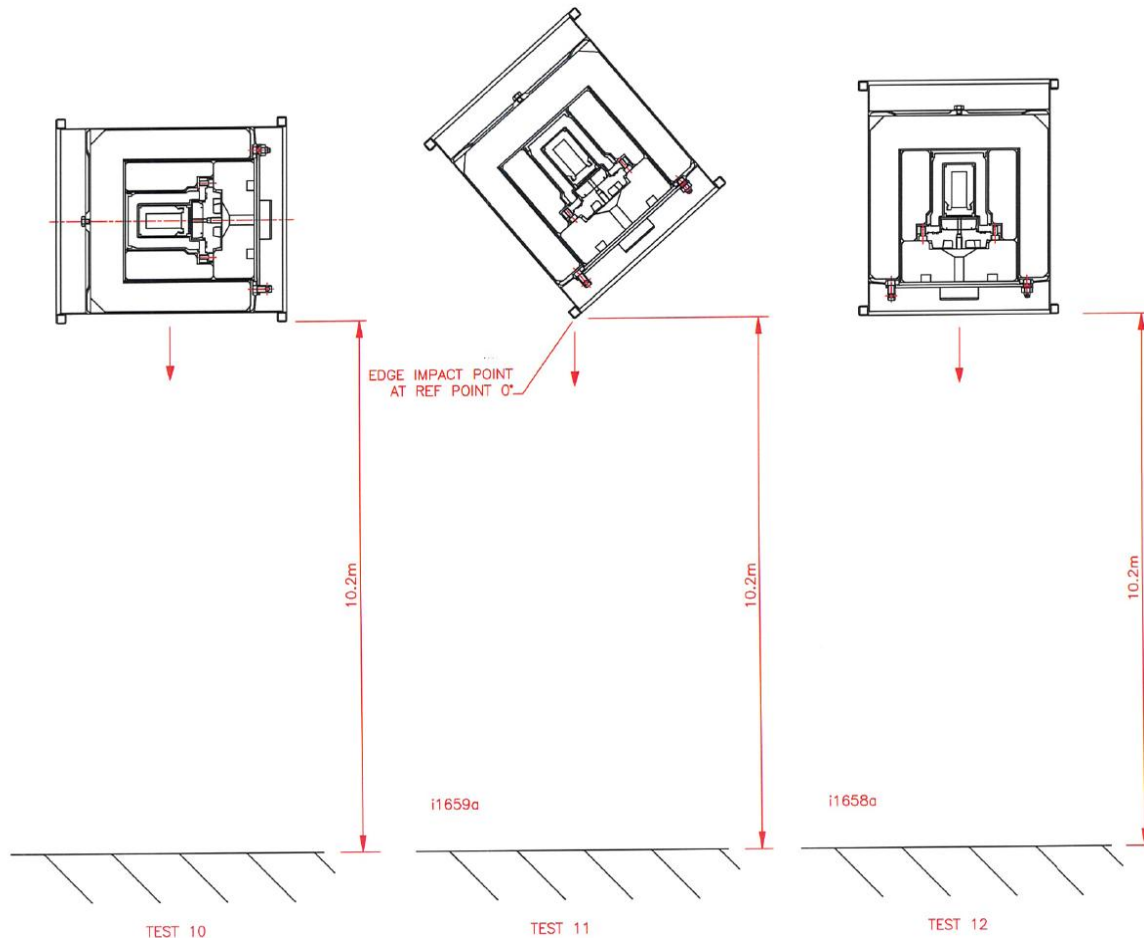

Figure 2-3 HAC Free Drop Impact Orientations

2.7.1.1 End Drop

The package was evaluated for a 10.2 m end drop occurring on the top of the package. This orientation is the worst case end drop because a drop on the lid may distort the lid and open the seals however this would not occur with a drop on the bottom. Testing of a prototype established the effect on the package along with a structural analysis determining the effect on the containment vessel.

Package Test

As described in Section 2.7.1. the prototype test package was cooled to -40°C and dropped onto its side, top corner and then the top end with damage from each drop accumulating for the next test. The end drop is described in the appended reports CTR 2009/21 and CTR 2009/27.

The package was slung in the correct orientation and dropped onto the test target. The package impacted the target on the top rim bounced and landed on its side.

The maximum g values recorded during the end drop are given in Table 2-30. The accelerations were measured by accelerometers attached to the lid of the containment vessel. The accelerometers logged at 100,000 samples per second. The raw data was filtered using a low pass digital 4th order Butterworth filter with a cut off frequency of 500 Hz. The maximum axial acceleration is 449g and the maximum radial acceleration is 192 g.

The keg received some minor denting which is discussed in Section 2.7.1.5.

Containment Vessel Evaluation

A detailed analysis of the stress present in the containment vessel during the free drop test was carried out using a finite element model of the containment vessel as described in the Vectra Group report 925-3272/R1(Section 2.12.2).

The end drop was modeled under 'hot' and 'cold' conditions as required by Regulatory Guide 7.8. The hot conditions assumed the package experienced the maximum ambient temperature of 38°C, in still air with maximum insolation and decay heat. With these conditions it was assumed that the containment vessel was at a uniform temperature of 150°C. Along with the hot temperature it was assumed that the containment vessel had an internal pressure of 800 kPa. The external pressure was taken as 100 kPa, so the internal gauge pressure was 700 kPa

The cold conditions assumed an ambient temperature of -29°C, in still air with no insolation or decay heat. It has been assumed that the internal pressure is 0 kPa with an external pressure of 100 kPa, so the internal gauge pressure is -100 kPa. The load combinations modeled for the NCT drop tests are outlined in Table 2-1.

A body force was applied to the model which was equivalent to an upward vertical acceleration of 430 g. This value was equivalent to the axial acceleration measured during the drop test as shown in Table 2-30.

For the entire HAC free drop analysis a pre load of 8.12kN was applied to the bolts at the start of the analysis, prior to any other loads being imposed. The bolts were tied to the CV body along the threaded length with the bolt heads free to slide.

Stress calculations were carried out for both the hot and cold end drop load combinations. Stress distributions presented in VECTRA report 925-3272/R1 (Section 2.12.2] indicated that under the hot and cold conditions the drop on the end causes a slight distortion of the lid due to the tungsten insert impacting the bottom of the lid.

The primary membrane (Pm), primary plus bending (Pm+Pb) stresses were evaluated at the locations shown on Figure 2-1, for each of the free drop load combination identified in Table 2-2. The maximum stress intensities calculated along with the location of the maximum stress is given for each free drop load combination. Each maximum stress is compared to the allowable stress intensity and the design margin given. All the design margins are greater than 0 therefore the containment vessel satisfies the requirements of Regulatory Guide 7.6. The lowest design margin calculated is 1.15 which is due to primary plus bending stresses on the CV liner which is located over the corner of the lead shielding.

The calculated values for average shear, average stress and maximum stress of the closure bolts for the end drop condition are summarized in Table 2-36. The design margin for the end drop condition are all greater than 0 therefore the bolts satisfy the requirements of Regulatory Guide 7.6 [2.3].

Buckling evaluations of the inner containment shell were carried out in accordance with the requirements of ASME Code Case N-284-2 [2.6]. The stresses used for the calculations were taken from point C4 in Figure 2-1, which is mid-way along the length of the inner shell of the containment vessel. Where one of the components was tensile in the finite element analysis it should be given a value of 0 Pa however in order to avoid zero errors it was given a very small positive value in the buckling calculation.

The maximum calculated buckling stresses are shown in Table 2-37 along with the design margins. A maximum buckling stress of 55.4 MPa was calculated. Table 2-37 shows that all the design margins are greater than 0 therefore the containment vessel will not buckle under an end drop and satisfies the requirements of Regulatory Guide 7.6 [2.3].

Table 2-35 End Drop Containment Vessel Stress Summary

HAC Case ID	Description	Stress Type	Maximum Stress Intensity (MPa)	Stress Location	Allowable stress intensity (MPa)	Minimum Design Margin
1	Drop on lid from 10.2m (hot)	P _m	124	C9	276	1.22
		P _m +P _b	193	C9	414	1.15
2	Drop on lid from 10.2m (cold)	P _m	87.0	C6	276	2.17
		P _m +P _b	193	C8	414	1.15

Table 2-36 End Drop Containment Vessel Bolt Stress Summary

HAC Case ID	Description	Stress Type	Maximum stress (MPa)	Allowable stress intensity (MPa)	Minimum design margin
1	Drop on lid from 10.2m (hot)	Average Shear	15.4	361	22.5
		Average Stress	154	602	2.90
2	Drop on lid from 10.2m (cold)	Average Shear	8.65	361	40.8
		Average Stress	87.9	602	5.85

Table 2-37 End Drop Containment Vessel Buckling Evaluation

NCT Case ID	Description	Stress (MPa)			Design Margin
		Axial Compression	Hoop Compression	In-plane shear	
7	Drop on lid from 1.2m (hot)	0	0	0.01	2.3 x 10 ⁷
8	Drop on lid from 1.2m (cold)	55.4	36.2	0.04	1.32

2.7.1.2 Side Drop

The package was evaluated for a 10.2 m side drop. Testing of a prototype established the effect on the package along with a structural analysis determining the effect on the containment vessel.

Package Test

As described in Section 2.7.1, the prototype test package was cooled to -40°C and dropped onto its side, top corner and then the top end with damage from each drop accumulating for the next test. The side drop is described in the appended reports CTR 2009/21 and CTR 2009/27 (Section 2.12.2). The package was slung in the correct orientation and dropped onto the test target. The package impacted the target with the bottom rim first and then rocked over for the secondary impact to occur on the top rim and came to rest on the side.

The maximum g values recorded during the end drop are given in Table 2-30. The accelerations were measured by accelerometers attached to the lid of the containment vessel. The accelerometers logged at 100,000 samples per second. The raw data was filtered using a low pass digital 4th order Butterworth filter [2.18] with a cut off frequency of 500 Hz. The maximum radial acceleration is 430 g and the maximum axial acceleration is 298 g.

The keg received some minor denting which is discussed in Section 2.7.1.5.

Containment Vessel Evaluation

A detailed analysis of the stress present in the containment vessel during the free drop test was carried out using a finite element model of the containment vessel as described in the Vectra Group report 925-3272/R1 (Section 2.12]. The commercial finite element code Abaqus/Standard v 6.8 was used for the analysis. A half symmetry model was generated because the geometry and load cases were all symmetrical about a vertical plane through the centre of the vessel. The model is described in detail in the Vectra report.

The side drop was modelled under 'hot' and 'cold' conditions as required by Regulatory Guide 7.8. The hot conditions assumed the package experienced the maximum ambient temperature of 38°C, in still air with maximum insolation and decay heat. With these conditions it was assumed that the containment vessel was at a uniform temperature of 150°C. Along with the hot temperature it was assumed that the containment vessel had an internal pressure of 800 kPa. The external pressure was taken as 100 kPa, so the internal gauge pressure was 700 kPa.

The cold conditions assumed an ambient temperature of -29°C, in still air with no insolation or decay heat. It has been assumed that the internal pressure is 0 kPa with an external pressure of 100 kPa, so the internal gauge pressure is -100 kPa. The load combinations modelled for the HAC drop tests are outlined in Table 2-1.

A body force was applied to the model which was equivalent to the radial value measured during the test. The measured g values are shown in Table 2-30 with the value of g applied to the model shown in Table 2-31.

For the entire HAC free drop analysis a pre load of 8.12kN was applied to the bolts at the start of the analysis, prior to any other loads being imposed. The bolts were tied to the CV body along the threaded length with the bolt heads free to slide.

Stress calculations were carried out for both the hot and cold end drop load combinations. Stress distributions presented in VECTRA report 925-3272/R1 (Section 2.12.2] indicated that under the hot and cold conditions the drop on the side causes the inner part of the body to rotate causing the lead shielding to compress. The cold conditions also were found to cause the tungsten insert to rotate.

The primary membrane (Pm), primary plus bending (Pm+Pb) stresses were evaluated at the locations shown on Figure 2-1, for each of the free drop load combination identified in Table 2-2. The maximum stress intensities calculated along with the location of the maximum stress is

given for each free drop load combination in. Each maximum stress is compared to the allowable stress intensity and the design margin given. All the design margins are greater than 0 therefore the containment vessel satisfies the requirements of Regulatory Guide 7.6 [2.3]. The lowest design margin calculated is 1.06 which is due to primary plus bending stresses on the CV cavity wall.

The calculated values for average shear, average stress and maximum stress of the closure bolts for each free drop condition are summarized in Table 2-39. The design margins for drop condition are all greater than 0 therefore the bolts satisfy the requirements of Regulatory Guide 7.6 [2.3].

Buckling evaluations of the inner containment shell were carried out in accordance with the requirements of ASME Code Case N-284-2 [2.6]. The stresses used for the calculations were taken from point C4 in Figure 2-1, which is mid-way along the length of the inner shell of the containment vessel. Where one of the components was tensile in the finite element analysis it should be given a value of 0 Pa however in order to avoid zero errors it was given a very small positive value in the buckling calculation.

The maximum calculated buckling stresses are shown in along with the design margin. A maximum buckling stress of 51.4 MPa was calculated. Table 2-40 shows that all the design margins are greater than 0 therefore the containment vessel will not buckle under an end drop and satisfies the requirements of Regulatory Guide 7.6 [2.3].

Table 2-38 Side Drop Containment Vessel Stress Summary

HAC Case ID	Description	Stress Type	Maximum Stress Intensity (MPa)	Stress Location	Allowable stress intensity (MPa)	Minimum Design Margin
3	Drop on side from 9m (hot)	P _m	132	C9-180	276	1.09
		P _m +P _b	201	C9-180	414	1.06
4	Drop on side from 9m (cold)	P _m	78.1	C2-180	276	2.53
		P _m +P _b	168	C2-180	414	1.46

Table 2-39 Side Drop Containment Vessel Bolt Stress Summary

HAC Case ID	Description	Stress Type	Maximum stress (MPa)	Allowable stress intensity (MPa)	Minimum design margin
3	Drop on side from 9m (hot)	Average Shear	11.2	361	31.1
		Average Stress	160	602	2.77
4	Drop on side from 9m (cold)	Average Shear	7.29	361	48.6
		Average Stress	92.0	602	5.54

Table 2-40 Side Drop Containment Vessel Buckling Evaluation

HAC Case ID	Description	Stress (MPa)			Design Margin
		Axial Compression	Hoop Compression	In-plane shear	
3	Drop on side from 9m (hot)	7.25	0	0.43	12.6
4	Drop on side from 9m (cold)	34.4	51.4	0.33	1.50

2.7.1.3 Corner Drop

The package was evaluated for a 10.2 m corner drop occurring on the top of the package. This orientation is considered the worst case corner drop because a drop on the top rim may distort the package lid and open the keg, this however would not occur with a drop on the bottom corner. Testing of a prototype established the effect on the package, with a structural analysis determining the effect on the containment vessel.

Package Test

As described in Section 2.7.1, a prototype test package was cooled to -40°C and dropped onto its side, top corner and then the top end with damage from each drop accumulating for the next test.

The package was slung in the correct orientation, raised to 10.2 m and dropped onto the test target. The package impacted the target on the top rim bounced, spun and landed on its side.

The maximum g values recorded during the corner drop are given in Table 2-30. The accelerations were measured by accelerometers attached to the lid of the containment vessel. The accelerometers logged at 100,000 samples per second. The raw data was filtered using a low pass digital 4th order Butterworth filter [2.18] with a cut off frequency of 500 Hz. The maximum axial acceleration is 388 g and the maximum radial acceleration is 177 g.

The keg received some minor denting which is discussed in Section 2.7.1.5.

Containment Vessel Evaluation

A detailed analysis of the stress present in the containment vessel during the corner drop test was carried out using a finite element model of the containment vessel as described in the Vectra Group report 925-3272/R1 (Section 2.12). The commercial finite element code Abaqus/Standard v 6.8 was used for the analysis. A half symmetry model was generated because the geometry and load cases were all symmetric about a vertical plane through the centre of the vessel. The model is described in detail in the Vectra report.

The corner drop was modeled under 'hot' and 'cold' conditions as required by Regulatory Guide 7.8 [2.2]. The hot conditions assumed the package experienced the maximum ambient temperature of 38°C, in still air with maximum insolation and decay heat. With these conditions it was assumed that the containment vessel was at a uniform temperature of 150°C. Along with the hot temperature it was assumed that the containment vessel had an internal pressure of 800 kPa. The external pressure was taken as 100 kPa, so the internal gauge pressure was 700 kPa.

The cold conditions assumed an ambient temperature of -29°C, in still air with no insolation or decay heat. It has been assumed that the internal pressure is 0 kPa with an external pressure of 100 kPa, so the internal gauge pressure is -100 kPa. The load combinations modeled for the HAC drop tests are outlined in Table 2-2.

A body force was applied to the model which was equivalent to a radial acceleration of 178g and axial acceleration of 388g. These g values are the maximum accelerations measured during the 10.2 meter free drop tests. The measured g values are shown in Table 2-30.

For the entire HAC free drop analysis a pre load of 8.12kN was applied to the bolts at the start of the analysis, prior to any other loads being imposed. The bolts were tied to the CV body along the threaded length with the bolt heads free to slide.

Stress calculations were carried out for both the hot and cold end drop load combinations. Stress distributions presented in VECTRA report 925-3272/R1 (Section 2.12) indicated that under the hot and cold conditions the drop on the top edge caused the lead shielding, along with the inner part of the body and the tungsten insert to rotate slightly.

The primary membrane (P_m), primary plus bending (P_m+P_b) stresses were evaluated at the locations shown on Figure 2-1, for each of the free drop load combination identified in Table 2-2. The maximum stress intensities calculated along with the location of the maximum stress is given for each corner drop load combination in Table 2-41. Each maximum stress is compared to the allowable stress intensity and the design margin given. All the design margins are greater than 0 therefore the containment vessel satisfies the requirements of Regulatory Guide 7.6. The lowest design margin calculated is 0.93 which is due to primary plus bending stresses on the flange which is located over the corner of the lead shielding.

The calculated values for average shear, average stress and maximum stress of the closure bolts for each free drop condition are summarized in Table 2-42. The design margins for drop condition are all greater than 0 therefore the bolts satisfy the requirements of Regulatory Guide 7.6 [2.3].

Buckling evaluations of the inner containment shell were carried out in accordance with the requirements of ASME Code Case N-284-2 [2.6]. The stresses used for the calculations were taken from point C4 in Figure 2-1, which is mid-way along the length of the inner shell of the containment vessel. Where one of the components was tensile in the finite element analysis it should be given a value of 0 Pa however in order to avoid zero errors it was given a very small positive value in the buckling calculation.

The maximum calculated buckling stresses are shown in Table 2-43 along with the design margin. Table 2-43 shows that all the design margins are greater than 0 therefore the containment vessel will not buckle under a corner drop, satisfying the requirements of Regulatory Guide 7.6 [2.3].

Table 2-41 Corner Drop Containment Vessel Stress Summary

HAC Case ID	Description	Stress Type	Maximum Stress Intensity (MPa)	Stress Location	Allowable stress intensity (MPa)	Minimum Design Margin
5	Drop on corner from 9m (hot)	P_m	130	C9-180	276	1.12
		P_m+P_b	201	C9-180	414	1.06
6	Drop on corner from 9m (cold)	P_m	105	C6-180	276	1.63
		P_m+P_b	215	C10-180	414	0.93

Table 2-42 Corner Drop Containment Vessel Bolt Stress Summary

HAC Case ID	Description	Stress Type	Maximum stress (MPa)	Allowable stress intensity (MPa)	Minimum design margin
5	Drop on corner from 9m (hot)	Average Shear	15.4	361	22.5
		Average Stress	157	602	2.84
6	Drop on corner from 9m (cold)	Average Shear	8.68	361	40.6
		Average Stress	89.5	602	5.73

Table 2-43 Corner Drop Containment Vessel Buckling Evaluation

HAC Case ID	Description	Stress (MPa)			Design Margin
		Axial Compression	Hoop Compression	In-plane shear	
5	Drop on corner from 9m (hot)	5.79	0	0.65	16.0
6	Drop on corner from 9m (cold)	61.2	47.0	0.09	1.10

2.7.1.4 Oblique Drops

An oblique drop is considered to produce lower “g”s and less damage to the package as less of the energy of the drop is absorbed in the initial impact. As the package does not have a large length to diameter ratio, increase of impact forces due to slap down cannot occur.

2.7.1.5 Summary of Results

The stress evaluation carried out on the containment vessel indicated that it satisfied all the applicable design criteria, therefore no significant deformation of the containment vessel or the closure bolts will occur. Testing of a prototype package confirmed that on completion of the NCT and HAC test series the containment vessel remained leak tight and undamaged as described in the Croft Associates report CTR 2009/21. The only damage suffered during the HAC drop tests was to the keg body which is discussed below.

HAC End Drop

The end drop was the final drop in the HAC test series so all the damage from the side drop and drop with the C of G over the top rim was present on the keg prior to the test. The end drop caused minimal damage to the top of the keg however the body of the keg was bellowed beneath the top rim.

HAC Side Drop

As discussed in the report CTR 2009/21 (Section 2.12.2), two HAC side drops were conducted with the first invalidated due to failure of test equipment. This meant that the keg had sustained a dent to the bottom of the keg. On carrying out the second 10.2 m drop test minimal additional damage was caused to the already dented bottom rim. Secondary impact caused minimal denting to the top rim. No damage was caused to the body of the keg.

HAC Corner Drop

The corner drop occurred on completion of the side drop, therefore the bottom rim was dented and the top rim had some very minor dents prior to the corner drop. The primary impact of the top rim with the target caused 12 mm of deformation to the top rim which caused the top skirt to deform. No other damage was caused to the keg.

2.7.2 Crush [71.73 (c)(2)]

The crush test is not required as the package has a density of 1,478 kg/m³. The calculation of the density of the package is described in CS 2010/11 [Section 2.12.2].

2.7.3 Puncture [71.73 (c)(3)]

10 CFR 71.73 (c) (3) requires that a package is dropped from 1m onto the upper end of a solid, vertical, cylindrical mild steel bar mounted on an essentially unyielding, horizontal surface. The package must be dropped onto the bar in the orientation in which the maximum damage is expected.

In order to fulfill this requirement a prototype package was dropped in the orientations illustrated in Figure 2-4, onto a steel punch with a diameter of 150 mm and 150 mm in length. The test procedure and results of the puncture tests are reported in the report CTR 2009/21 (Section 2.12.2) and summarized in this section.

The first three puncture tests were carried out at ambient temperature prior to the 10.2m drop tests. This is because the HAC drop tests can result in the cork crushing which increases the density. This increase in density causes the increase in the cork crush strength, therefore a puncture test on a damaged package would have less impact than a test on an undamaged package.

The package orientations chosen are illustrated in Figure 2-4. These orientations are those expected to cause the maximum damage to the package. The final puncture test (test 12a) illustrated in Figure 2-4 was carried out with the package at -40°C after the 10.2m drop test series. This test allowed the effects of brittle fracture during the punch test to be assessed. It also ensured that the maximum damage had been caused to the seal area of the containment vessel prior to the thermal test.

The penetration drops on the bottom end and the top rim resulted in minimal damage to the keg. The side penetration drop resulted in a dent of 14.6 mm in depth in the side of the keg. The penetration test carried out at -40°C on the top of the keg bent one of the keg handles. No tearing or penetration of the keg skin was observed.

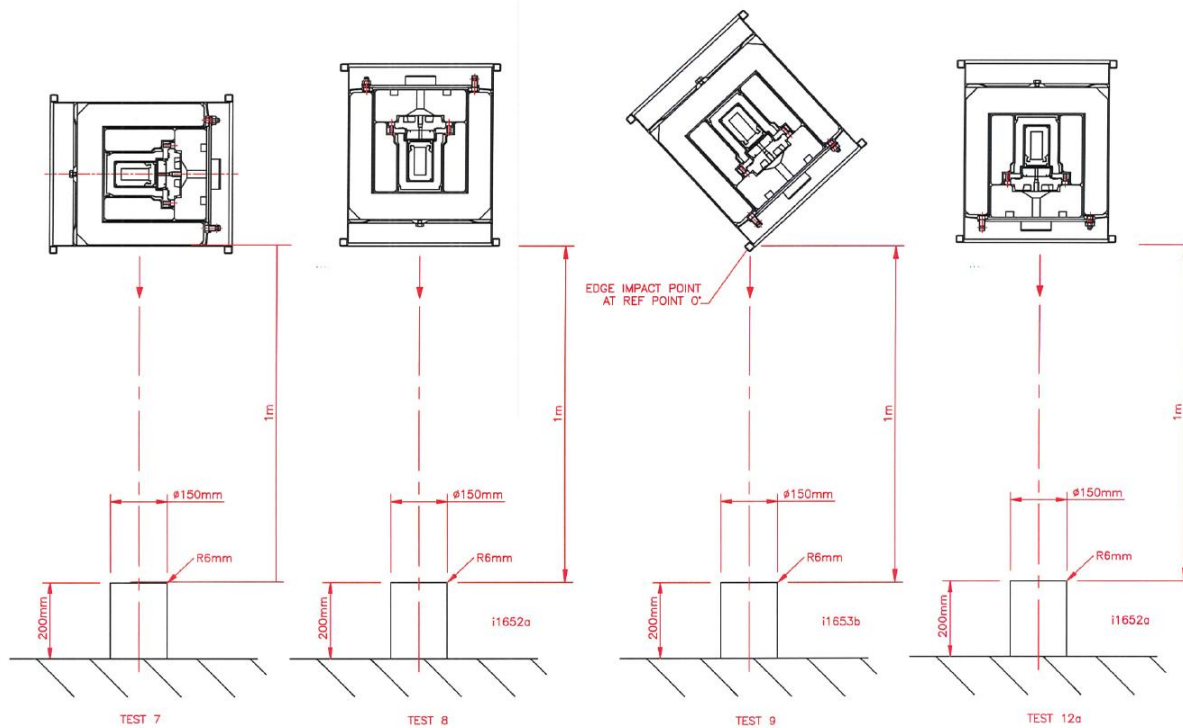

Figure 2-4 Puncture Tests Impact Orientations

2.7.4 Thermal [71.73 (c)(4)]

10 CFR 71.73 (c) (4) requires that the package can withstand a 30 minute fire with an average flame temperature of 800°C. The requirement was demonstrated by carrying out a thermal test on a prototype package after it had undergone a NCT penetration test, NCT drop tests, HAC puncture tests and HAC drop tests. The thermal test has been reported in Section 3.10.2. The analyses of the structural design during the thermal test are presented within this section.

2.7.4.1 Summary of Pressures and Temperatures

During the thermal test the keg skin reaches a maximum temperature similar to that of the fire (800°C). The containment vessel insulated from the full effect of the fire by the cork reaches a maximum temperature of 184°C with a heat load of 10W from the contents. The temperature each component reaches during the HAC thermal test is within its maximum allowable service temperature.

A calculation of the actual maximum pressure expected under HAC is provided in Calculation Sheet CS 2009/08 (Section 2.12.2) – the calculated maximum pressure is 2 bar (200 kPa).

The free volume within the CV is 78 cc – this is based on the air gap between the Tungsten Insert and CV cavity of 33cc + the cavity volume of the Tungsten Insert of 55cc less an allowance of 10 cc for solid contents of the Tungsten Insert (see restriction in Table 1-8 under Product containers “The volume limit of the Product containers and packing shall be <10cc). Therefore breaching of the product container containing the gas (of maximum amount 25

bar.cc) would increase the pressure in the CV by a maximum of 0.32 bar (given by the volume ratio 25/78).

The containment vessel maximum internal pressure during the HAC fire is assumed to be 10 bar or 1000 kPa gauge for the design evaluation.

HAC Operating Condition	CV
Assumed Max. Temperature	200°C
Max. Pressure	10 bar (1,000kPa) gauge 11 bar (1,100kPa) abs
Min. Temperature	-40°C
Min. Pressure	-1 bar (-100 kPa) gauge 0 bar (0 kPa) abs

2.7.4.2 Differential Thermal Expansion

The HAC thermal evaluation shows that on initiation and on completion of the fire there is no significant temperature gradient over the lead shielding and the stainless steel cladding. Therefore it is expected that the differential thermal expansion is bounded by the results for the NCT heat test discussed in section 2.6.1.2.

2.7.4.3 Stress Calculations

In accordance with the ASME code the stresses in the package resulting from temperature loading are classified as secondary and need not be evaluated under HAC. The HAC thermal evaluation shows that the thermal gradient of the containment vessel under HAC will be negligible and therefore bounded by the NCT heat test discussed in section 2.6.1.3.

2.7.4.4 Comparison with Allowable Stress

The HAC thermal test stresses are bounded by the stresses in the NCT thermal test. As detailed in Section 2.6.1.4 all the maximum stresses are less than the allowable stresses. Therefore the package meets the requirements under HAC conditions.

2.7.5 Immersion – Fissile Material [71.73 (c)(5)]

The quantity of fissile material to be carried does not depend on water exclusion for criticality safety and therefore this water immersion test is not required,

2.7.6 Immersion – All Packages [71.73 (c)(6)]

71.73(c)(6) requires that a package be subjected to a maximum external pressure due to immersion under 15 m (50 ft) of water (equivalent pressure is 150 kPa gauge).

The maximum pressure differential that could occur under the water immersion condition arises from external pressure of 150 kPa combined with a reduced internal pressure of 0 kPa absolute giving a maximum pressure differential of 150 kPa.

As described in section 2.6.4, the effect of an increased external pressure of 140 kPa with the worst case initial conditions has been determined: the maximum stresses encountered and the minimum design margins are presented in Table 2-44. In order to determine the effect of an external pressure of 150 kPa, the stresses calculated for an external pressure of 140 kPa have

been scaled by $150/140 = 1.07$: the results are given in Table 2-44. Scaling of the stresses indicates that the design margins are all greater than zero. This demonstrates the containment vessel will be acceptable under an immersion test.

Table 2-44 Containment Vessel Stress Summary for Immersion

.NCT Case ID	Description	Stress Type	Maximum Stress Intensity (MPa)	Stress Location	Allowable stress intensity (MPa)	Minimum Design Margin
4	Increased External Pressure	P _m	44.9	C2	115	1.56
		P _m +P _b	86.8	C2	173	0.99
		P _m +P _b +Q	82.1	C4	345	3.2
		Bearing	68.7	Under bolts	172	1.50

2.7.7 Deep Water Immersion Test (for Type B Packages Containing More than 105 A2) [71.61]

Not applicable as the contents are $< 10^5 A_2$.

2.7.8 Summary of Damage

The mechanical damage sustained by the package during the NCT and HAC test series is reported in CTR 2009/21 [Section 2.12.2]. The testing was carried out in series with the NCT drop testing, followed by the HAC puncture tests, HAC drop tests and the HAC thermal test.

The NCT drop tests caused minimal denting to the rim of the keg at the points of impact. The puncture tests also caused minimal damage to the keg rim however the side puncture test did cause an indent of 14.6 mm on the side of the keg. The 10.2 meter drop tests caused more severe denting to the top and bottom rims with the drop test over the top rim causing a 12 mm dent and the side drop causing a dent to the bottom rim.

The thermal test was carried out on completion of the HAC drop and puncture tests, to determine if the damaged package was able to withstand the rigors of this test. During the test the package skin reached 800°C however the containment vessel was insulated by the design and to some extent by the damage and only reached a temperature of 110°C which is within the operational range of the containment seal. On completion of the test series the keg and the components were inspected and revealed that the outer cork was charred with the inner and top cork partially charred.

On completion of the test series, examination of the containment vessel found no damage and no change in the measured dimensions. Leak tests carried out prior to and on completion of testing detected no signs of leaks, indicating that the containment vessel remained leak tight throughout the NCT and HAC tests. Additionally the force required to maintain compression of the containment O-ring is 9.9 kN, Table 2-45 below demonstrates that the total bolt force for all eight bolts at the end of each analysis in the FEA. As shown in the table all are well in excess of the 9.9 kN required and therefore will maintain compression in the containment O-ring.

The examination of the containment vessel (as detailed in report CTR 2009/21, Table 9, page 46, under the table section headed Containment Vessel in rows 12 -15), showed the outside diameter of the CV body at lower and mid height of the body at reference and 90° to reference – all are seen to be close to the nominal diameter of 118.5 mm and there are no significant

changes following the drop test program. This demonstrates that there was no distortion of the CV shell due to lead slumping.

Table 2-45 Total Bolt Force After Analysis

Case ID	Total Bolt force (for all eight Bolts) (kN)
NCT1	84.7
NCT2	52.4
NCT3	84.7
NCT4	54.6
NCT5	84.7
NCT6	54.5
NCT7	84.9
NCT8	55.1
NCT9	84.9
NCT10	55.2
NCT11	85.1
NCT12	55.3
HAC1	95.1
HAC2	55.5
HAC3	95.2
HAC4	54.9
HAC5	95.3
HAC6	55.6

2.8 Accident Conditions for Air Transport of Plutonium [71.74]

Not applicable – air shipment of $> A_2$ plutonium is not required.

2.9 Accident Conditions for Fissile Material Packages for Air Transport [1.55(f)]

Not applicable – air shipment of fissile materials is not required.

2.10 Special Form [71.75]

Special form is not claimed for the contents or for any part of the package.

2.11 Fuel Rods

Irradiated fuel rods are not to be carried in this package.

2.12 Appendix

2.12.1 References

- [2.1] Title 10, Code of Federal Regulations, Part 71, Office of the Federal Register, Washington D.C.
- [2.2] Regulatory Guide 7.8, *Load Combinations for the Structural Analysis of Shipping Casks for Radioactive Material*, Revision 1, U.S. Nuclear Regulatory Commission, Office of Standards Development, March 1989.

- [2.3] Regulatory Guide 7.6, *Design Criteria for the Structural Analysis of Shipping Cask Containment Vessels*, Revision 1, March 1978.
- [2.4] American Society of Mechanical Engineers (ASME) Boiler and Pressure Vessel Code, Section III, Division 3, *Containment Systems for Storage and Transport Packagings of Spent Nuclear Fuel and High Level Radioactive Material and Waste*, 1977 Edition.
- [2.5] American Society of Mechanical Engineers (ASME) Boiler and Pressure Vessel Code, Section III, Division 3, *Containment Systems for Storage and Transport Packagings of Spent Nuclear Fuel and High Level Radioactive Material and Waste*, 2001 Edition with Addenda through July 1, 2003.
- [2.6] American Society of Mechanical Engineers (ASME) Boiler and Pressure Vessel Code, Section III, Division 1, Code Cases: Nuclear Components, Case N-284-1, *Metal Containment Shell Buckling Design Methods, Class MC*, 2001 Edition with Addenda through July 1, 2003.
- [2.7] Regulatory Guide 7.11, *Fracture Toughness Criteria of Base Material for Ferritic Steel Shipping Cask Containment Vessels with a Maximum Wall Thickness of 4 Inch (0.1 m)*, U.S. Nuclear Regulatory Commission, Office of Standards Development, June 1991.
- [2.8] NUREG/CR-3854, *Fabrication Criteria for Shipping Containers*, U.S. Nuclear Regulatory Commission, Washington D.C., April 1984.
- [2.9] American Society of Mechanical Engineers (ASME) Boiler and Pressure Vessel Code, Section III, Division 1, Subsection NB, *Class 1 Components*, 2001 Edition with Addenda through July 1, 2003.
- [2.10] American Society of Mechanical Engineers (ASME) Boiler and Pressure Vessel Code, Section III, Division 1, Subsection NF, *Supports*, 2001 Edition with Addenda through July 1, 2003.
- [2.11] NUREG/CR-6407, INEL-95/0551, *Classification of Transportation Packaging and Dry Spent Fuel Storage System Components According to Importance to Safety*, February 1996
- [2.12] American Society of Mechanical Engineers (ASME) Boiler and Pressure Vessel Code, Section XI, *Ferrous Material Specification, 2007 Edition with Addenda through July 1, 2009*
- [2.13] American National Standards Institute, for Radioactive Material, *Leakage Tests on Packages for Shipment*, ANSI N14.5-2022 edition
- [2.14] NUREG CR/3019, UCRL-53044 *Recommended Welding Criteria for Use in the Fabrication of Shipping Containers for Radioactive Materials*, March 1984
- [2.15] Parker Hannifin Corporation, *Parker O-ring Handbook*, ORD 5700/USA, 2001.
- [2.16] American Society of Mechanical Engineers (ASME) Boiler and Pressure Vessel Code, Section II, Part D, *Materials*, 2001 Edition with Addenda through July 1, 2003.

- [2.17] American Society of Mechanical Engineers (ASME) Boiler and Pressure Vessel Code, Section V, *Non Destructive Examination*, 2001 Edition, with Addenda through July 1, 2001
- [2.18] *Vibration, Measurement and Analysis*, JD Smith, Butterworth-Heinemann
- [2.19] *Zeitstachuntersuchungen an Blei und Bleilegierungen (Investigations on Long Term Behaviour of lead and Lead-Alloys)* K. Gerischer und CM Meyenbug
- [2.20] American Society of Mechanical Engineers (ASME) Boiler and Pressure Vessel Code ASME, "ASME BPVC.II.D.M-2019 - ASME Boiler and Pressure Vessel Code," 2019.

2.12.2 Supporting Documents

Document Reference	Title
SERCO/TAS/002762/01 (ETR 313)	Compression Testing of Cork
Vectra, 925-3272/R1 (ETR 317)	Stress Analysis of Safkeg LS 3979A Containment Vessel
Vectra, 925-3272/M2 (ETR 325)	Safkeg LS 3979A Mesh Sensitivity Analysis
CTR 2009/21	Prototype SAFKEG LS 3979A/0002 NCT and HAC Regulatory Test Report
CTR 2009/27	Prototype SAFKEG LS 3979A/0002 NCT and HAC Regulatory Test Report
CS 2009/08	SAFKEG-LS 3979A – Maximum Pressure in CV
CS 2010/10	Calculation of the Density of the 3977A Package
Vectra, 925-3274/R1 (ETR 327)	Safkeg LS 3979A – Additional HAC Case
CTN 2025/01	[REDACTED]

(Croft [External](#) [Technical](#) [Report](#) reference)

3 Thermal Evaluation

Contents

3	Thermal Evaluation	3-1
3.1	Description of Thermal Design	3-1
3.1.1	Design Features	3-2
3.1.2	Content's Decay Heat [71.33 (b)(7)]	3-3
3.1.3	Summary Tables of Temperatures.....	3-3
3.1.4	Summary Tables of Maximum Pressures	3-5
3.2	Material Properties and Component Specifications	3-6
3.2.1	Material Properties.....	3-6
3.2.2	Component Specifications	3-8
3.3	Thermal Evaluation under Normal Conditions of Transport.....	3-10
3.3.1	Heat and Cold.....	3-13
3.3.2	Maximum Normal Operating Pressure [71.33 (b)(5)].....	3-17
3.4	Thermal Evaluation under Hypothetical Accident Conditions	3-17
3.4.1	Initial Conditions	3-17
3.4.2	Fire Test Conditions [71.73 (c)(4)]	3-17
3.4.3	Maximum Temperatures and Pressure	3-21
3.4.4	Maximum Thermal Stress	3-25
3.4.5	Accident Conditions for Fissile Material Packages for Air Transport [71.55(f)]	3-25
3.5	Appendix	3-26
3.5.1	References	3-26
3.5.2	Supporting Documents	3-27

Introduction

This section identifies the key thermal design features for the Safkeg-LS 3979A package. The maximum temperatures at both NCT and HAC conditions have been calculated for these features by a Finite Element Analysis (FEA) and a thermal model of the package. The FEA and the thermal model of the package were validated against testing of a prototype Safkeg-LS 3979A package under both steady state internal heating and an 800°C fire test. The test procedure and results of the tests and the FEA are presented and discussed.

The maximum operational temperatures determined for the maximum contents heating have been listed and shown to be lower than the maximum design temperatures of the package.

3.1 Description of Thermal Design

The Safkeg-LS 3979A is designed to transport a range of nuclides, with a maximum allowable heat output of 10 W. The following sections detail the design features affecting the thermal performance of the package.

3.1.1 Design Features

The only design features that are significant with respect to heat transfer in the Safkeg-LS 3979A are:

- The stainless steel keg outer skin
- The stainless steel keg inner liner
- The cork liner
- Top cork and side cork
- The stainless steel containment vessel
- The lead shielding in the containment vessel

These features are all axi-symmetric and are illustrated in Figure 3-1.

The keg and the cork provide the containment vessel with protection from impact and fire. Under HAC fire conditions the keg skin is designed to heat up very quickly with the cork providing insulation to the containment vessel, as a result of its low thermal conductivity and ablation properties. Since heating of the cork during the HAC fire causes gas evolution within the keg cavity, a fuse plug is provided in the bottom of the keg. On heating above 98°C the fuse plug melts allowing pressure relief of the keg cavity.

The package does not have any mechanical cooling.

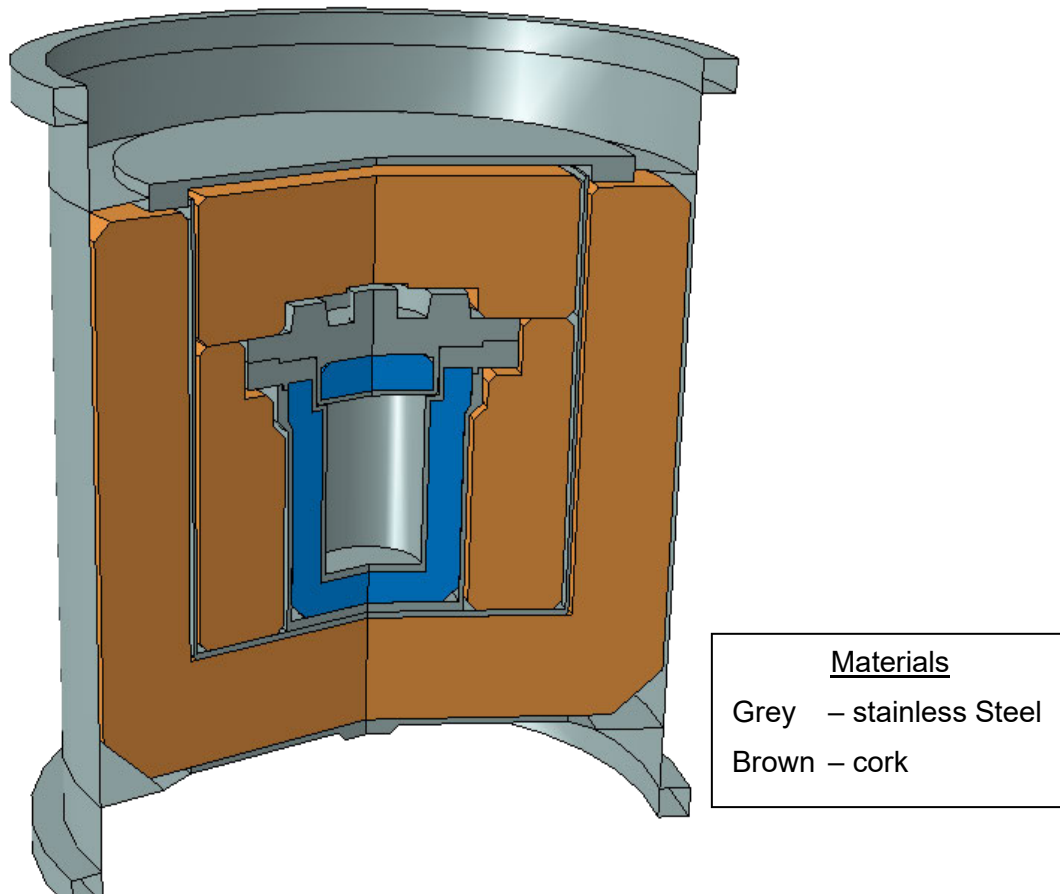

Figure 3-1 Thermal Design Properties

3.1.2 Content's Decay Heat [71.33 (b)(7)]

The contents decay heat is limited to a maximum of 10 W for solids.

3.1.3 Summary Tables of Temperatures

The maximum temperatures reached under NCT and HAC conditions have been determined using an FEA thermal model detailed in the report SERCO/TAS/5388/001 appended in Section 3.5.2. Table 3-1 summarizes the results of this report and presents the maximum temperatures reached in the containment vessel cavity with internal heat loads from 0 to 10 Watts under NCT and HAC thermal conditions.

The maximum temperatures within the containment vessel are generated at 10 W, therefore the temperatures reached at critical locations with this heat load were calculated in the SERCO report under NCT and are summarized here in Table 3-2. The maximum temperatures calculated are all within the acceptable temperature limits for the package components.

The temperature of the Shielding Inserts under NCT and HAC conditions with contents emitting 10W has been determined in Calculation Sheet CS 2010-16 [appended in Section 3.5.2] as 12°C above that of the CV body: this is based on the worst case assumption that all the heat from the contents, which is emitted as radiation, is absorbed within the Shielding Insert. The

maximum resulting temperatures of the Shielding Inserts calculated are presented in Table 3-2 and Table 3-3: these temperatures are within the acceptable temperature limits for the all the components of the inserts.

Table 3-1 Calculated Maximum Containment Vessel Temperature under NCT and HAC

(Ambient 38°C, with and without insolation)

Heat load (W)	Maximum Temperature under heat load (°C)				
	0	3	5	6	10
NCT – no insolation	38	55.8		72.8	94.2
NCT – with insolation	63.7	80.4	91.1 (1)	96.4	116.4
HAC – with insolation	139.6	153.5	162.41 (1)	166.9	184

1 Interpolated

Table 3-2 Summary of Calculated Package Temperatures with 10 W Internal Heat Load under NCT (Ambient 38°C, with and without insolation)

Location	Maximum Temperature (°C)		Temperature Limit (°C)
	No insolation	With Insolation	
Shielding Insert	106.2	128.4	427 (1)
Shielding Insert seal	106.2	128.4	135 (4)
Containment vessel cavity	94.2	116.4	427 (1)
Containment vessel lid seal	94	116	135(4)
Cork (2)	94	116	180 (3)
Keg lid	43	104	427 (1)
Keg bottom	46	75	427 (1)
Mid height on keg surface	42	68	427 (1)

- 1 The allowable temperature limit for steel when relied upon for structural support is 427°C as specified in ASME Section II Part D [3.1].
- 2 Maximum cork temperature is same as the CV which it carries.
- 3 [3.7]
- 4 EP O-ring temperature limit for continuous operation

The minimum package temperature is limited by the ambient conditions, therefore the minimum temperature of the package is assumed to be -40°C.

Table 3-3 summarizes the data obtained from the SERCO report (section 3.5.2) for the peak temperatures in the package resulting from the HAC thermal test and the period of post test heating of the internal parts of the package. As can be seen, all the CV components remain within acceptable temperature limits.

Table 3-3 Summary of Package Temperatures for HAC Thermal Test (Ambient 38°C, with and without insulation)

Location	Maximum Temperature (°C)	Time after Fire initiation (mins)	Temperature Limit (°C)
Shielding Insert	196	225 (3)	427
Shielding Insert seal	196	225 (3)	200 (1)
Containment vessel cavity	184	225	1427
Containment vessel lid seal	183	225	200 (1)
Cork	775	30	NA (2)
Lead Shielding	182	225	252
Keg lid	775	30	1427
Keg bottom	775	30	1427
Mid height on keg surface	780	30	1427

- 1 The containment lid seal remains above the continuous operation temperature of the O-ring of 130-135°C for 8 ¼ hours. Batch testing of the seals prior to use, as detailed in section 8.1.5.2, assures that the O-ring will perform satisfactorily after a period of 24 hours at 200°C.
- 2 Cork ablates under high temperatures and leaves a low density carbonaceous layer which provides insulation equivalent to still CO₂.
- 3 The Inserts would reach maximum temperature nominally at the same time as the peak in CV temperature with possibly a small time lag.

3.1.4 Summary Tables of Maximum Pressures

Table 3-4 shows the maximum design pressure under NCT and HAC.

Table 3-4 Summary Table of Maximum Pressures in the Containment Vessel

Case	Maximum Pressure
MNOP	7 bar (700kPa) gauge 8 bar (800kPa abs)
HAC	10 bar (1,000kPa) gauge 11 bar (1,100kPa abs)

3.2 Material Properties and Component Specifications

3.2.1 Material Properties

The materials affecting heat transfer within and from the package are cork, lead and stainless steel type 304L. The thermal properties for each material are summarized in Table 3-5.

Table 3-5 Thermal Properties of Packaging Materials

Material	Property	Temperature (°C)	Value	Reference
304 Stainless Steel	Conductivity	21	14.9 W/m/K	[3.1]
		38	15.0 W/m/K	
		93	16.1 W/m/K	
		149	16.9 W/m/K	
		205	18.0 W/m/K	
		260	18.9 W/m/K	
		316	19.5 W/m/K	
		371	20.4 W/m/K	
		427	21.1 W/m/K	
		482	22.0 W/m/K	
		538	22.8 W/m/K	
		593	23.5 W/m/K	
		649	24.2 W/m/K	
		705	25.1 W/m/K	
		760	25.8 W/m/K	
	816	26.5 W/m/K		
		Density	-	7900 kg/m ³
	Specific Heat	21	483 J/kg/K	[3.1]
		38	486 J/kg/K	
		93	506 J/kg/K	
		149	520 J/kg/K	
		205	535 J/kg/K	
		260	544 J/kg/K	
		316	551 J/kg/K	
		371	559 J/kg/K	
		427	562 J/kg/K	
		482	570 J/kg/K	
		538	577 J/kg/K	
	593	583 J/kg/K		
	649	585 J/kg/K		

Material	Property	Temperature (°C)	Value	Reference
		705	591 J/kg/K	
		760	596 J/kg/K	
		816	601 J/kg/K	
Lead	Conductivity	-	29.7 W/m/K	[3.3]
	Density	-	11040 kg/m ³	[3.4]
	Specific Heat	-	133.9 J/kg/K	[3.3]
	Melting Point		Solidus 252°C Liquidus 290°C	[3.5] [3.6]
Cork	Conductivity	-	See Figure 3-4	[3.7]
	Density	-	290 kg/m ³	[3.7]
	Specific Heat	-	1650 J/kg/K	[3.7]e
Air (1)	Conductivity	0	0.0243 W/m/K	[3.8]
		100	0.0314 W/m/K	
		200	0.0386 W/m/K	
		400	0.0515 W/m/K	
		800	0.0709 W/m/K	

- 1 The thermal conductivity was used to represent heat transfer across the air gaps in the model. The model did not include the thermal capacity of air. No data was therefore required for the density or specific head of air

During a fire the cork experiences temperatures up to ~800°C. No measurements of cork properties at high temperatures are available. However, the HAC thermal test has been performed on the Safkeg-LS 3979A package as detailed in report CTR 2009/21 (Section 2.12.2). The test has then been simulated in order to validate the model against the measured data and, to demonstrate the acceptability of the thermal properties assumed for the cork. It was found that, in order to obtain agreement with the measured temperatures, the thermal conductivity of the cork needed to be increased by 50%. It should be noted that these thermal properties, validated against the furnace test, are 'effective' properties that include any effects of charring and shrinkage of the cork.

The NCT thermal test performed on the Safkeg-LS 3979A package has also been simulated using the model. It was found that, to produce the best agreement with the measured temperatures, the thermal conductivity of the cork needed to be reduced by 15%. Because cork is a natural material, this degree of variation in conductivity may well be possible. To ensure that all the calculations performed with the model are pessimistic, the lower, fitted conductivity has been assumed for the calculations of temperature during normal transport and the higher, measured thermal conductivity assumed for the calculations of temperature during the fire accident. Values used for the thermal conductivity of the cork are shown in Figure 3-2.

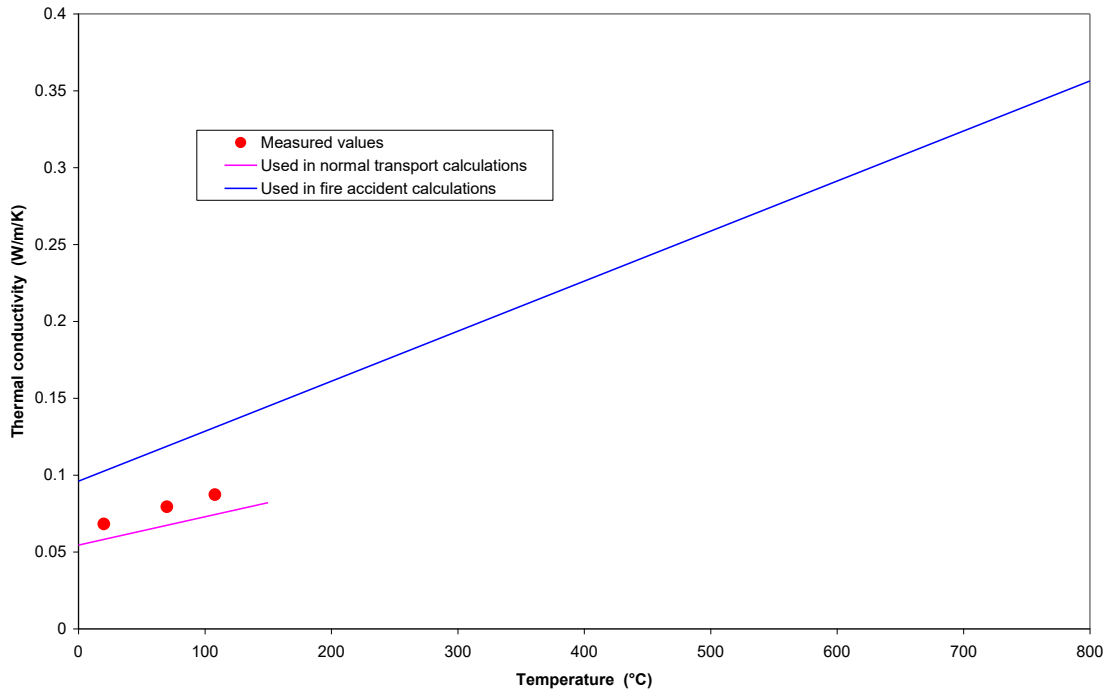

Figure 3-2 Thermal Conductivity of Cork

The package surface and internal emissivity values used in the thermal evaluation are given in Table 3-6. The emissivity of stainless steel can vary significantly depending upon the surface finish and level of oxidation. The values presented in Table 3-6 are shown to produce good agreement with the measured temperatures in the steady state heating test carried out in report CTR 2009/21 (Section 2.12.2) and are discussed in depth in Sections 3.3 and 3.4.2.

Table 3-6 Emissivities used in the Thermal Model

Material	Condition	Value	Reference
304 Stainless Steel	Internal surfaces	0.2	[3.9]
	External surface – heating test	0.4	Fitted to measured surface temperature in heating test.
	External surface - NCT	0.25	[3.9]
	External surface – fire test	0.8	[3.10]
Cork	All conditions	0.95	[3.11]

3.2.2 Component Specifications

The components that are important to thermal performance are the outer keg, the cork packing material, the containment vessel and the containment seal. The outer keg and the containment

vessel are manufactured from stainless steel 304L with the containment seal manufactured from Ethylene propylene rubber.

The allowable service temperatures for all the components cover the maximum and minimum temperatures anticipated during NCT and HAC conditions of transport. The minimum allowable service temperature for all components is less than or equal to -40°C . The maximum service temperature for each component is determined from the temperatures calculated from the thermal model.

The upper temperature reached by the stainless steel in the keg is 104°C for continuous operations and 780°C for short term operations. The upper temperature reached by the stainless steel in the containment vessel is 116°C for continuous operations and 184°C for short term operations under HAC conditions.

The allowable temperature limit for steel when relied upon for structural support is 427°C as specified in ASME Section II Part D [3.1]. During the HAC test the temperature of the keg skin exceeds this temperature for a short period of time. During a fire the steel is providing shielding to the cork from the direct exposure of the flames, its main function is not providing structural support therefore the maximum allowable temperature it can reach is 1427°C , which is the melting point of steel.

The lead shielding reaches a maximum temperature of 116°C for continuous operations and 183°C during HAC conditions. The lead does not provide any structural function therefore it is limited by its solidus which is 252°C .

The cork is unaffected by temperatures up to at least 140°C which is higher than the maximum temperature for any position in the cork packing under NCT. Under HAC conditions the cork reaches a maximum temperature of 775°C . Cork ablates under high temperatures and leaves a low density carbonaceous layer which provides insulation equivalent to still CO_2 .

The upper temperature reached by the containment seal is 116°C for continuous operation (NCT conditions), and 183°C for short term operation (HAC conditions). The temperatures under NCT conditions are within the allowable range of the O-ring material properties. The O-rings are specified as Ethylene Propylene rubber to ASTM D2000 M3 BA 810 A14 B13 F17 Z1, where Z1 stands for hardness of 75 ± 5 IRHD (or Shore A) (see drawings in Section 1.3.3). EP has a recommended temperature range of -57°C (-70°F) to 150°C (302°F) for continuous static and dynamic use with a maximum temperature of up to 204°C (400°F) for 2 hours duration as specified in the Parker O-Ring Handbook [3.12]. The ASTM D2000 standard F17 ensures that the O-ring material is suitable for use at -40°C . The critical characteristic tests specified section 8.1.5.2 provides assurance that the material supplied for use in packages, provides the required degree of sealing at 130°C for 1000 hours and at 200°C for 24 hours.

Note. The NCT 1000 hour temperature test mentioned above was reduced from 150°C to 130°C for Revision 8 of this SARP, as justified in CTR 2021/22 [3.5.2], with confirmatory testing reported in CTR 2021/24 [3.5.2].

Under HAC conditions the O-ring remains above 149°C for $8\frac{1}{4}$ hours reaching a maximum temperature of 183°C . Therefore the O-rings operate outside of the temperature ranges specified. In order to validate the O rings for use, each batch of O-rings will be tested to ensure they meet the critical requirement of remaining leak tight after 24 hours at 200°C - the test is specified in the drawings in section 1.3.3.

3.3 Thermal Evaluation under Normal Conditions of Transport

The Safkeg-LS 3979A package has been evaluated for compliance with 10 CFR 71 by thermally modeling the package. The thermal model has been validated by comparison against both an experimental self heating test (simulating normal conditions of transport) and a furnace test (simulating the fire accident), both carried out by Croft and documented in report CTR 2009/21 (Section 2.12.2).

NCT Thermal Test

A 10 W cartridge heater located inside an aluminum block was placed in the cavity of the containment vessel. The package was orientated in the vertical position on a wooden board covered with aluminum foil. The temperature of the package was monitored using thermocouples located in seven positions on and in the package. One thermocouple was located in the aluminum block, three thermocouples on the containment vessel surface, one on the keg liner and two on the keg surface. Temperatures were logged every minute until the package temperature reached equilibrium. The surface temperature of the package was then mapped using a temperature probe. The package was repositioned in the horizontal orientation and the temperatures logged until the package reached thermal equilibrium. The surface temperature of the keg was mapped using a temperature probe.

Thermal Model

The analytical model is described in detail the Report SERCO/TAS/5388/001 (Section 3.5.2). An axi-symmetrical model was generated with 5159 nodes and 2538 elements using the Abaqus code [3.13]. Each of the components was generated separately and joined, thermally, using tied constraints or interactions (representing narrow air gaps). The thin outer skin of the keg was modelled using 'shell' elements while all the other components were modelled using solid elements.

It was assumed that heat was lost from the package through natural convection and radiation from external surfaces. The convection coefficients used are described in detail in report SERCO/TAS/5388/001 (Section 3.5.2). The heat generated by the package contents was represented in the model as a uniform heat flux applied over the side, top and bottom of the cavity inside the containment vessel. The package contents themselves were not represented in the model.

Narrow gaps present were represented as air gaps, heat transfer across these gaps was assumed via conduction and thermal radiation. The sensitivity of the air gaps were discussed in the SERCO letter CJF10302 for NCT and HAC conditions. This letter demonstrated that the air gaps are relatively unimportant to the thermal performance of the package.

The package design also creates a number of small cavities across which radiation heat transfer will occur (in such small cavities heat transfer by conduction and convection is expected to be negligible). In these cavities radiation exchange between all the surfaces is modelled. The view factor from each element to each other element in the cavity is determined and radiation heat transfer, including the effect of reflection, then calculated.

The predicted temperatures from the model were compared against the actual values obtained. This comparison showed that the temperature of the containment vessel was initially underestimated. The calculation showed that, as expected, the majority of the temperature difference between the containment vessel and the outer surface of the keg results from heat transfer through the cork. It was therefore concluded that the low predicted containment vessel

temperature was probably due to the thermal conductivity of the cork being lower than assumed in the model. The calculation was therefore repeated with the thermal conductivity of the cork reduced by 15%. Such a variation in thermal conductivity is considered possible in a natural material such as cork.

The external surface temperature was also initially moderately overestimated. The assumed value of the surface emissivity was therefore increased from the reference value of 0.25 to 0.4. The emissivity of stainless steel can vary significantly depending upon the surface condition (e.g. level of oxidation) and a value of 0.4 is well within the range of possible values.

The predicted temperatures in the repeat calculation are in good agreement with those measured in the test. The predicted temperature profile is shown in report SERCO/TAS/5388/001 Figure 5 (Section 3.5.2) and it can be seen that, as expected, the highest temperatures occur in the heater block and inner containment vessel and high temperature gradients are generated in the cork. The temperatures measured in the steady state test and the predicted temperatures are summarised in Figure 3-3 (report SERCO/TAS/5388/001 (Section 3.5.2)). The temperatures initially predicted by the model are also shown on this Figure. The predicted temperatures agree with the temperatures measured by the fixed thermocouples to within 1.2°C. The predicted temperature on the outside of the keg, at the bottom, is around 2°C higher than the measured values. This is probably due to the board on which the container was sitting being modelled as perfectly insulating whereas, in practice, there was some heat loss through the board.

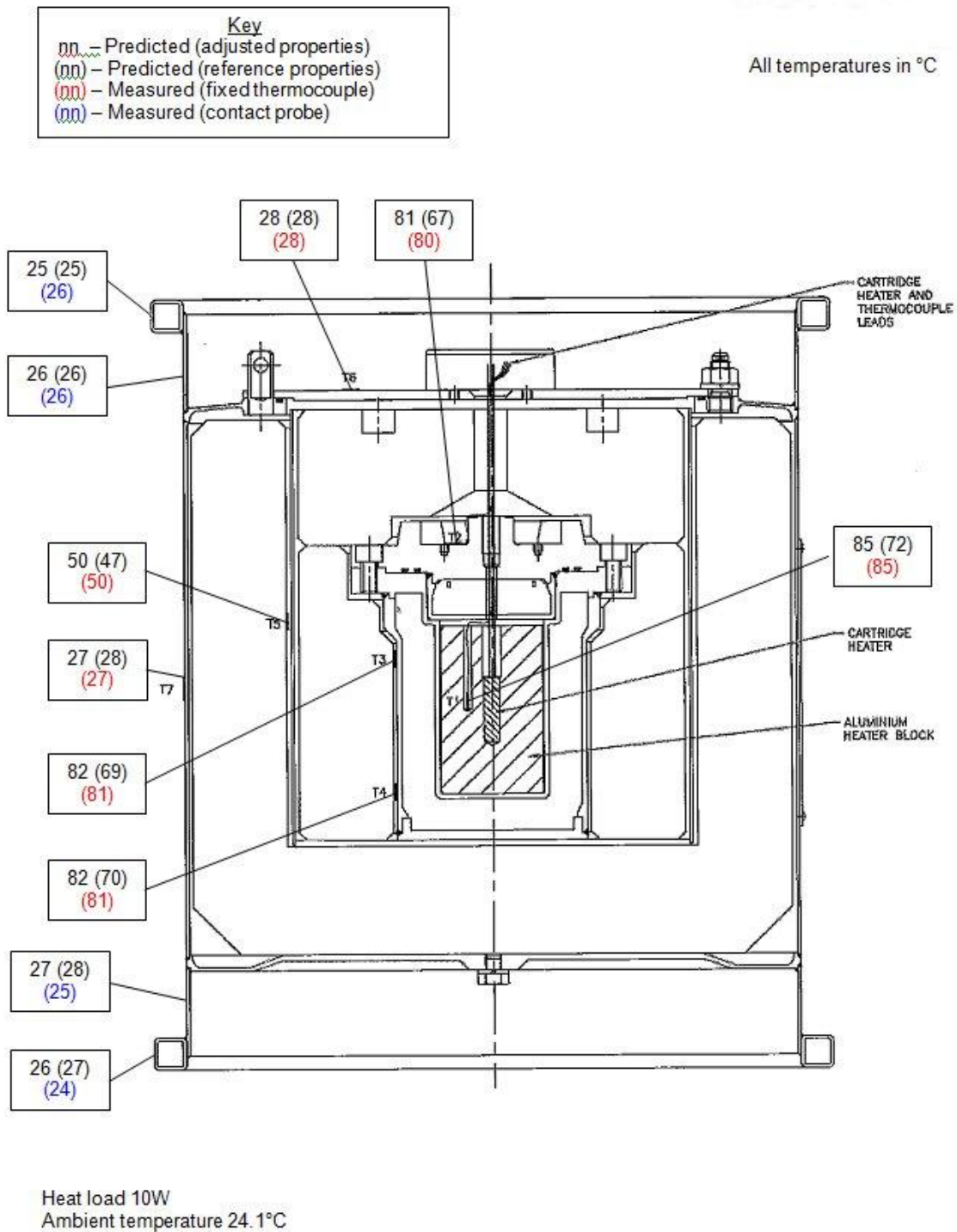

Figure 3-3 Comparison of Measured and Predicted Temperatures in the Steady-State Heating Test

3.3.1 Heat and Cold

The finite element model has been used to determine the temperature of the container under normal conditions of transport in the absence of solar insolation as described in the report SERCO/TAS/5388/001 (Section 3.5.2). A steady state calculation was performed which represented the container, stood vertically on an insulating surface, with heat loads of 0W, 3W, 6W and 10W and an ambient temperature of 38°C.

Heat losses to ambient by radiation and natural convection from the sides and top of the keg were simulated. In the validation of the model against the self heating test it was found that the best agreement was obtained with the thermal conductivity of the cork reduced by 15% compared to the measured values. To ensure that the temperatures predicted under normal conditions of transport are pessimistic, the lower, adjusted, thermal conductivity value has been used.

When modelling the heat test the surface emissivity was increased to 0.4 in order to improve the agreement between predicted and measured temperatures. To ensure that the temperatures predicted under normal conditions of transport are pessimistic, the lower, reference, emissivity value of 0.25 has been used.

The maximum temperatures reached, under NCT with no insolation and ambient of 38°C, at the containment seal and on the keg surface are given in Table 3-2. As shown the maximum temperature of the accessible surface is 43°C which is reached on the keg lid, the base of the keg reaches 46°C however this surface is not accessible and therefore not considered. This demonstrates that the package is capable of fulfilling the requirements of 71.73 (g) as the accessible surface temperature is less than 50°C with maximum contents heat load of 10W.

The package temperatures have also been modeled under normal conditions of transport and subject to solar insolation as described in the report SERCO/TAS/5388/001 (Section 3.5.2). Heat loads of 0, 3, 6 and 10 W were applied with an ambient temperature of 38°C. Transient calculations were performed covering a period of 4½ days with solar insolation incident upon the container for 12 hours each day.

Calculations were performed corresponding to both the horizontal and vertical orientation of the container. It was found that, at the end of each insolation period, the temperature of the inner container was around 1°C hotter in the vertical orientation than in the horizontal orientation due to the greater insolation heat flux onto the top of the container. The temperatures corresponding to vertical orientation of the container are therefore presented and also used as the starting point for the fire test calculation.

Figure 3-4 shows the transient temperature at various locations on the outer surface of the keg with a 10W heat load. The highest temperatures occur on the top of the container because the insolation flux is greater on the top than on the side. The maximum predicted temperature, which occurs on the top, is 104°C. Figure 3-5 shows the transient temperature at the inner containment vessel lid seal. It can be seen that the maximum temperature has effectively been reached after 1½ days. The maximum seal temperature is predicted to be 116°C. Figure 3-6 shows the maximum temperatures throughout the package under NCT.

The peak temperatures experienced during NCT conditions with insolation are shown in Table 3-2 along with the allowable maximum temperatures for each component listed. Each component has a large thermal margin with the smallest being the containment seal with a thermal margin at 34°C.

For the NCT cold evaluation the package is assumed to be in an ambient of -40°C , with zero insolation and zero heat decay. No analysis has been carried out because it has pessimistically been assumed that the package and all the components will eventually reach thermal equilibrium at -40°C . This temperature is within the allowable service limits for all the components.

The temperatures reached are within the NCT bounding conditions for the package which are as follows:

NCT Operating Condition	CV
Assumed Max. Temperature	120°C
Max. Pressure (MNOP)	7 bar (700kPa) gauge 8 bar (800kPa) abs
Min. Temperature	-40°C
Min. Pressure	-1 bar (-100 kPa) gauge 0 bar (0 kPa) abs

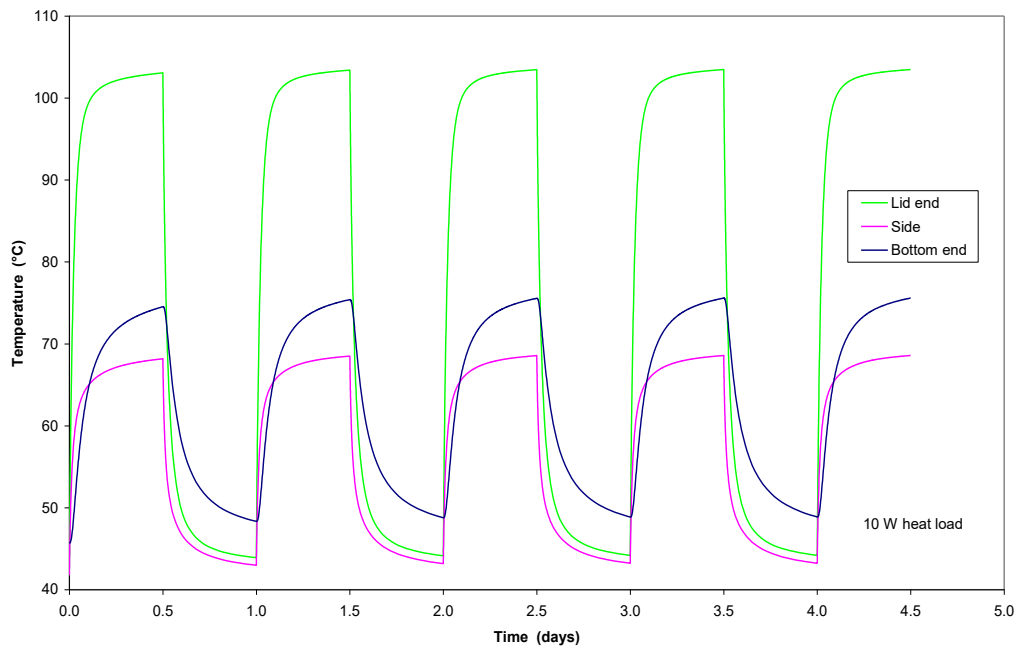

Figure 3-4 Predicted temperature on the Outside of the Keg During Normal Transport with Insolation

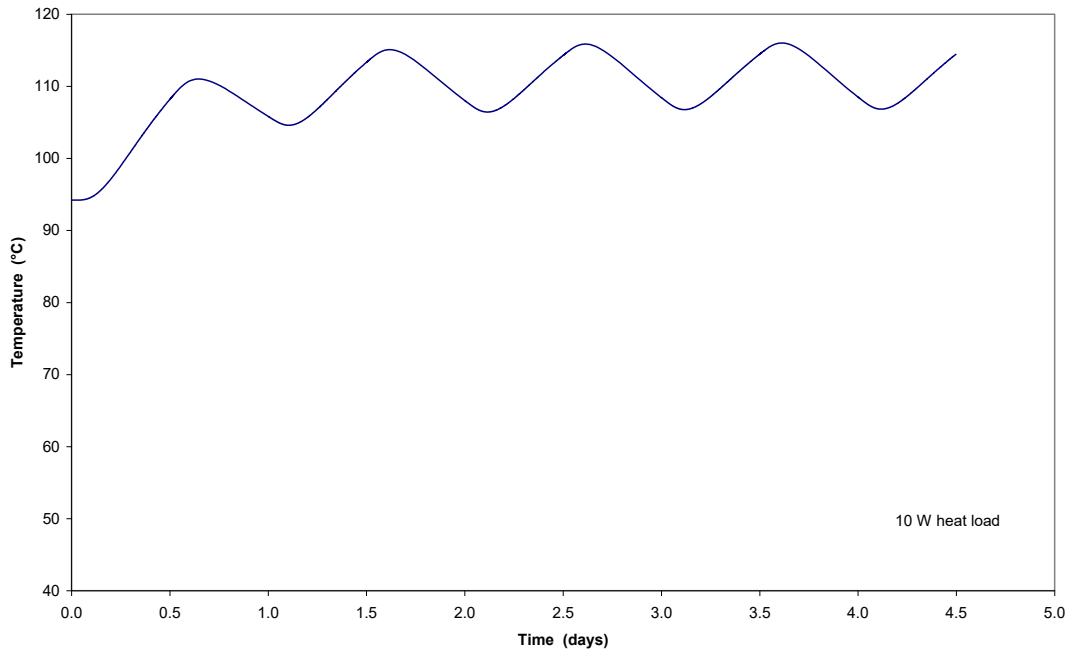

Figure 3-5 Predicted Temperature at the Containment vessel lid Seal During Normal Conditions of Transport with Insolation

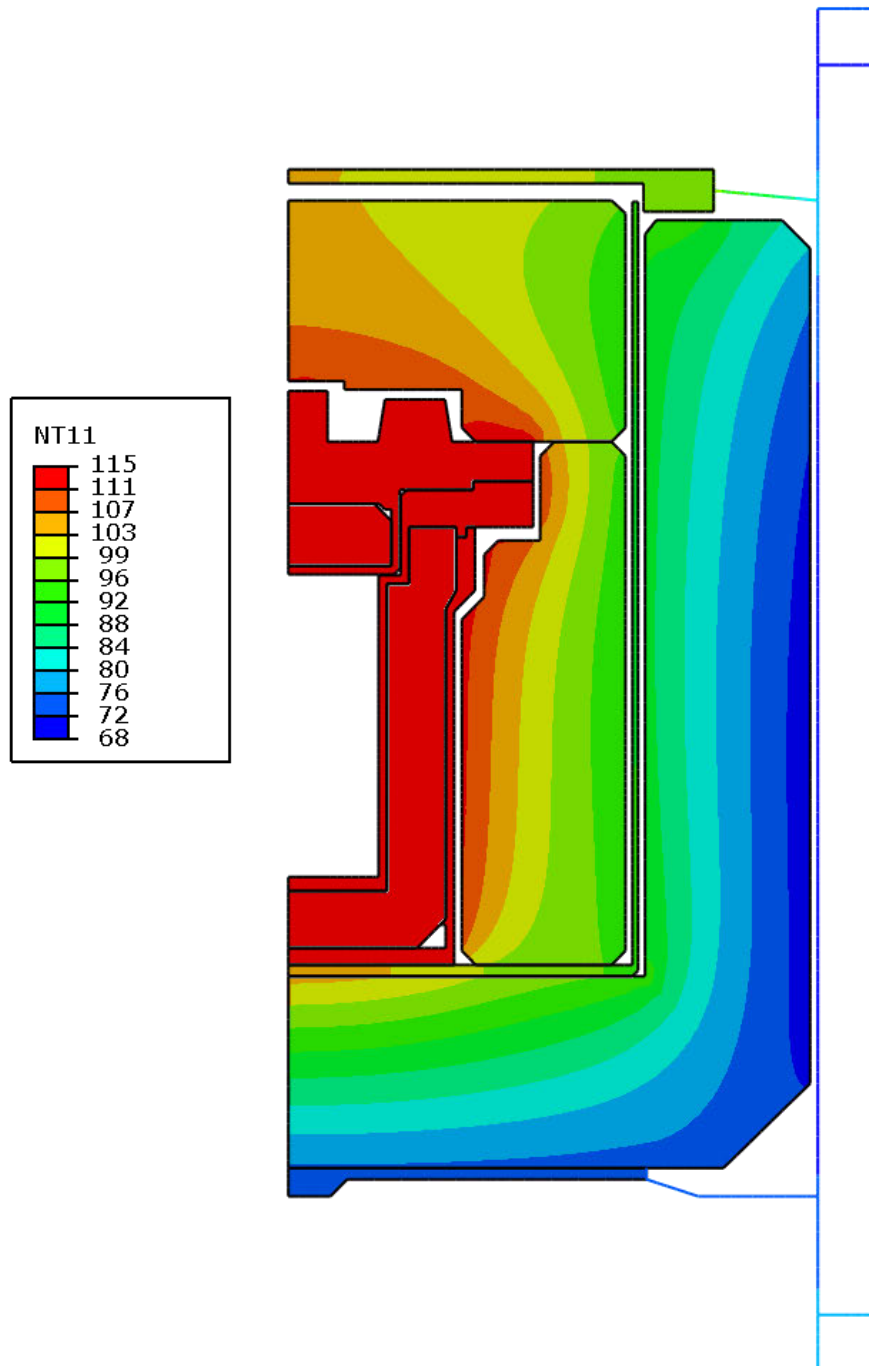

Figure 3-6 Predicted Temperature Profile under Normal Conditions of Transport With Solar Insolation

3.3.2 Maximum Normal Operating Pressure [71.33 (b)(5)]

The MNOP is 7 bar (700 kPa) gauge.

For solid contents emitting 10W, under NCT the maximum temperature of the CV is 116°C and the maximum temperature of the Shielding Insert and air within the CV is 128°C. Assuming the content were loaded at -40°C and a pressure of 1 bar abs, the pressure at the maximum temperature of the Shielding Insert, calculated according to Boyle's and Charles' Laws of 128°C, would be 1.72 bar (172kPa) gauge (see Calculations Sheet CS 2009/08), which is well within the design envelope.

The bounding temperatures and pressures for the package are as follows.

NCT Operating Condition	CV
Assumed Max. Temperature	120°C
Max. Pressure	7 bar (700kPa) gauge 8 bar (800kPa) abs
Min. Temperature	-40°C
Min. Pressure	-1 bar (-100 kPa) gauge 0 bar (0 kPa) abs

3.4 Thermal Evaluation under Hypothetical Accident Conditions

3.4.1 Initial Conditions

The initial conditions used for the thermal model of the fire test are taken at the end of a 12 hour period of insolation under Normal Conditions of Transport with a content decay heat of 10 W. All components are at their maximum temperatures as shown in Table 3-2.

3.4.2 Fire Test Conditions [71.73 (c)(4)]

The thermal assessment of the package under fire conditions has been carried out using a finite element model. The model was validated against a fire test carried out on a prototype Safkeg-LS 3979A package and then used to calculate the temperatures experienced during a fire with the initial conditions specified in section 3.4.1.

Fire Test

The fire test was carried out within a series of regulatory tests described in the report CTR 2009/21 (Section 2.12.2). A prototype package that had undergone the NCT and HAC drop and penetrations tests was placed into a furnace which was heated to 800°C. Once the package reached 800°C the thermal test was started and the package remained in the furnace for 30 minutes. During the fire test the temperature of the package was logged with eight thermocouples. Two were on the containment vessel lid, four were attached to the keg body, one was attached to the keg lid and one was attached to the keg base. The thermocouples logged the temperature of the package every 10 seconds until the termination of the test. The containment vessel and insert were also instrumented with temperature sensitive strips.

The temperatures recorded during the furnace test are shown in Figure 3-7; the data shows that the thermocouple output during the time that the package was in the furnace are false: it is understood that this is due to small thermocouples being used which are affected by the case of the thermocouple being at nominally 800°C. Once the package was removed from the furnace, the thermocouples provided valid temperature data.

On completion of the 30 minutes test period, the package was removed from the furnace. The package was allowed to cool naturally with temperatures logged until the temperature of the package peaked and began to decrease.

Validation of the Thermal Model

The thermal model described in Section 3.3 was modified with the addition of a tungsten insert containing lead shot and changing the boundary conditions in order to model the fire test carried out during the regulatory testing.

The lead shot was represented as a solid material filling the cavity inside the tungsten insert. There was assumed to be good heat transfer between the sides, top and bottom of the containment vessel and the tungsten insert and between the tungsten insert and the lead shot. These are pessimistic assumptions since they will tend to minimise the temperature increase predicted by the model (and hence reduce the level of conservatism compared to the measured data). The density of the lead shot material was adjusted to give a total mass of 42g.

During the heating phase of the furnace test all exterior surfaces of the keg were assumed to receive heat by forced convection and radiation from the furnace. A convection coefficient of 10W/m²/K was assumed (the value suggested in the Advisory Material for the IAEA Regulations [3.14]). The absorptivity of the surface of the keg was assumed to be 0.8 (the value specified in the IAEA Regulations [3.14]). It was recognised that the predicted temperature of the inner containment vessel would be insensitive to these heat transfer boundary conditions because the exterior skin of the keg, which has very little thermal capacity, will rapidly rise to near the temperature of the furnace.

The prototype Safkeg-LS 3979A package was placed inside the furnace by removing its lid and this resulted in the furnace being significantly cooler than 800°C when the package is first placed inside. This is why the package was inside the furnace for longer than the Regulatory 30 minutes. The temperature of the furnace increased back to 800°C over the first 19 minutes of the test. Unfortunately, the temperature provided from the furnace controller, as a function of time, was not sufficiently accurate for modelling purposes and the thermocouple attached to the support frame also gave false readings. However, the temperature of the exterior skin of the keg is expected to rapidly reach the furnace temperature. In the model, therefore, the temperature provided from the furnace controller was used as a guide but the modelled furnace

temperature was adjusted in order to give good agreement between the predicted outer keg skin temperature and the maximum measured skin temperature, as a function of time. These temperatures are shown in Figure 3-7.

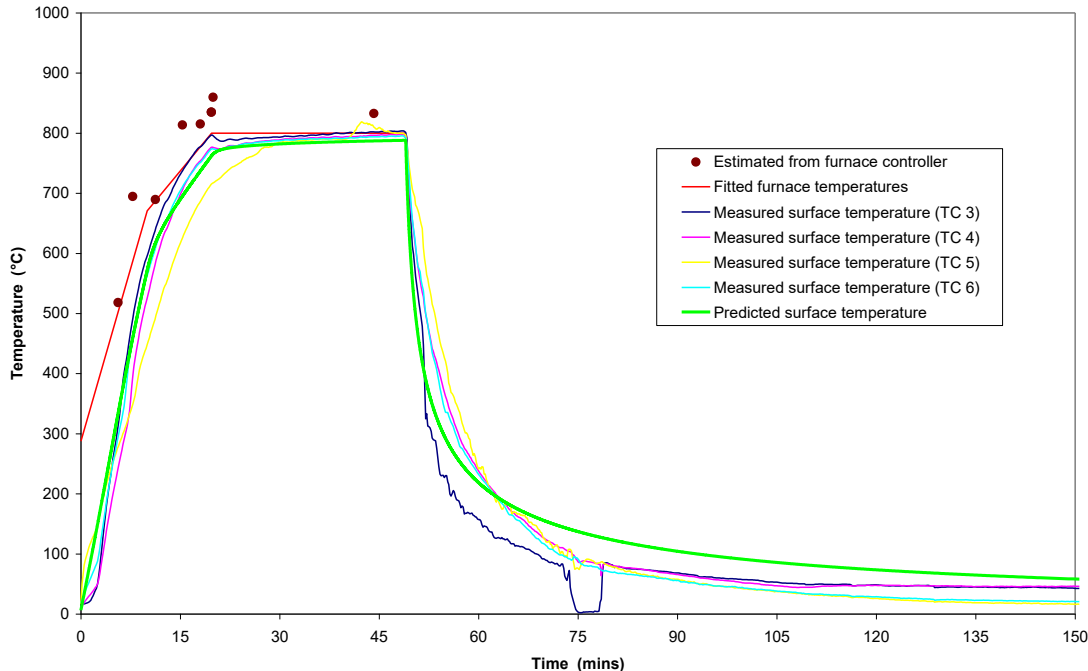

Figure 3-7 Furnace Temperature and External Surface Temperature in the Fire Test

During the cooling phase, heat was modelled as being lost from all exterior surfaces of the keg by radiation and natural convection. The emissivity of the surface of the keg was assumed to remain at 0.8, the value assumed during the heating phase (pictures of the container show the surface to be blackened and oxidised by the furnace). Established correlations for natural convection were again used to derive the appropriate convection coefficient (see Appendix 2 of report SERCO/TAS/5388/001 (Section 3.5.2)).

The predicted temperature of the containment vessel was initially much lower than the measured value. It was therefore concluded that the effective thermal conductivity of the cork was higher than had been assumed. The thermal conductivity of the cork (which was initially based on a linear extrapolation of the measured values) was therefore increased by 50%. It should be noted that this thermal conductivity in the model is an effective conductivity which includes possible additional heat transfer mechanisms such as evaporation and condensation of water or waxes.

The resulting predicted temperature at the location of the thermocouples on the containment vessel lid is compared against the measured values in Figure 3-8. The temperatures measured while the container was inside the furnace are believed to have been influenced by the flames inside the furnace and are hence unreliable. The temperatures measured during the cooling phase, however, are reliable and the maximum measured temperature agrees well with the temperature sensitive strip in this location. The general trend in measured temperature is predicted correctly but the predicted temperature lags behind the measured value but the

maximum temperature is predicted reasonably well. The maximum temperature is overestimated by 2.5°C.

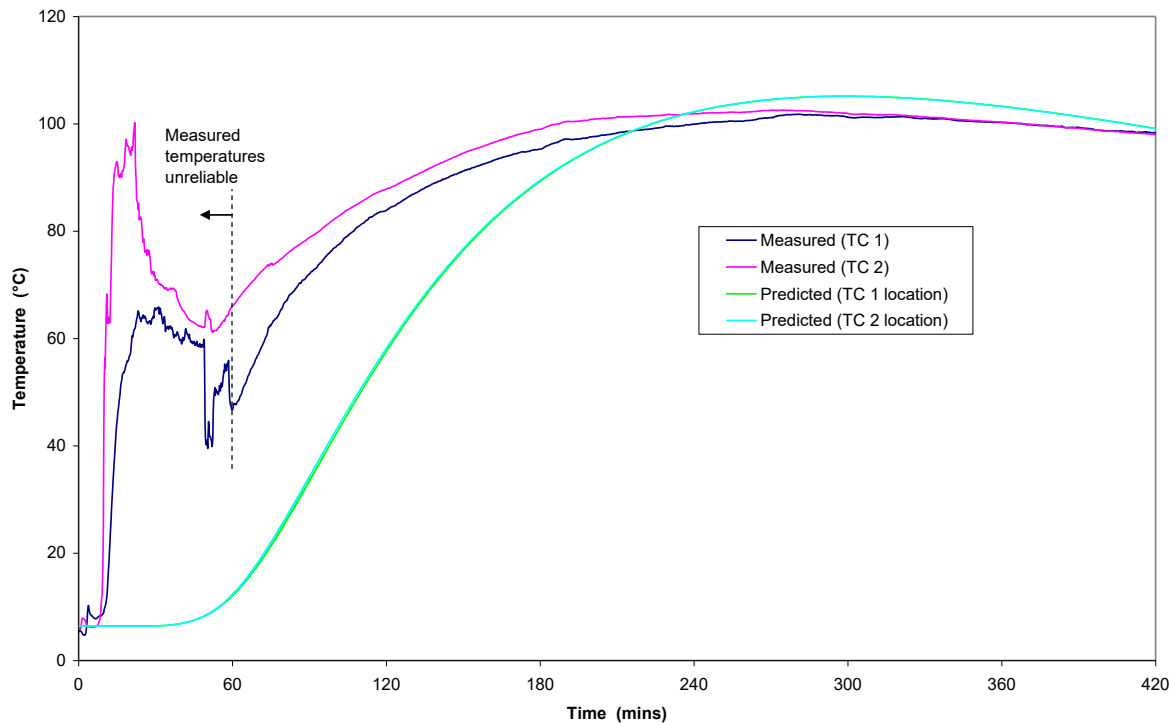

Figure 3-8 Comparison of Predicted and Measured Temperature of the Containment Vessel Lid in the Fire Test

It is therefore concluded that, with the adjusted cork conductivity, the finite element model is slightly pessimistic with respect to the peak inner containment seal temperature predicted during the fire test.

Thermal Model Used During the Fire Accident

The finite element analysis was used to determine the temperature of the container during the HAC fire test. A 30 minute, 800°C fire was simulated followed by a 12 hour cooling period.

During the heating phase, the model was the same as that used to validate the furnace test except:

- The tungsten insert and lead shot inside the inner containment vessel were removed.
- A heat load of 10W was applied to the inner surface of the containment vessel.
- The fire temperature was fixed at a constant value of 800°C.
- The convection heat transfer coefficient was increased from 10W/m²/K to 15 W/m²/k to ensure that the value was pessimistic.
- The duration of the fire was reduced to 30 minutes.
- The calculation started from the temperature profile obtained for normal conditions of transport with insulation.

10 CFR 71.73 requires the thermal test to be performed upon a container which has already been subjected to the regulatory impact tests. A series of NCT and HAC drop and penetration

tests was carried out on a prototype package (see Section 2.12.2). These tests caused denting of the top and bottom skirts of the package with minimal damage to the keg body.

These 'skirts' are not significant to the thermal performance and it is judged that the damaged 'skirt' would provide greater protection in a fire than an undamaged 'skirt' (since, when bent over, it will provide shielding of the top and bottom of the keg from the fire). The finite element model used to model the fire accident was therefore unchanged from that used to model Normal Conditions of Transport.

Although the temperature profile at the start of the fire test calculation corresponded to that at the end of a 12 hour period of solar insolation, solar insolation was (pessimistically) also applied during the 12 hour cooling phase of the fire accident calculation.

During the cooling phase, the boundary conditions were the same as those used to model normal conditions of transport (with the container vertical) except that the emissivity of the keg outer surface was assumed to be 0.8. The results of the HAC thermal evaluation are discussed in section 3.4.3.

3.4.3 Maximum Temperatures and Pressure

The maximum temperatures experienced by the components of the Safkeg-LS 3979A package calculated under a HAC fire test, with an ambient temperature of 38°C and insolation, are given in Table 3-3. The temperature each component reaches during the HAC thermal test is within its maximum allowable service temperature.

At the end of the heating phase the external surface of the keg is close to the temperature of the fire (800°C). Figure 3-9 shows the predicted temperature on the exterior surface of the keg. As measured in the furnace test detailed in report CTR 2009/21 (Section 2.12.2), the outer skin of the keg heats up and cools down rapidly because it is insulated from the inner containment vessel by the cork. The temperature of the keg lid changes more slowly than that of the side or base because the lid is thicker than the outer shell and therefore has a greater thermal capacity.

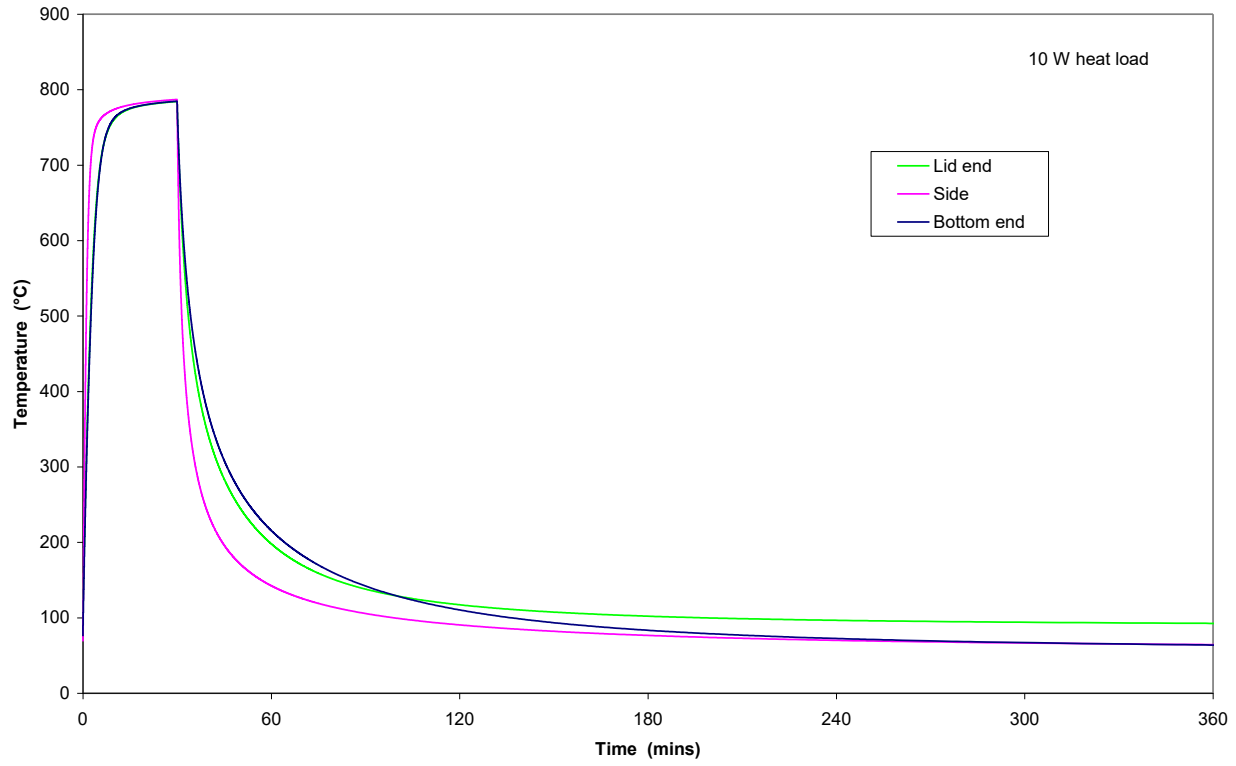

Figure 3-9 Predicted Temperature of the Outside of the Keg during the Fire Test

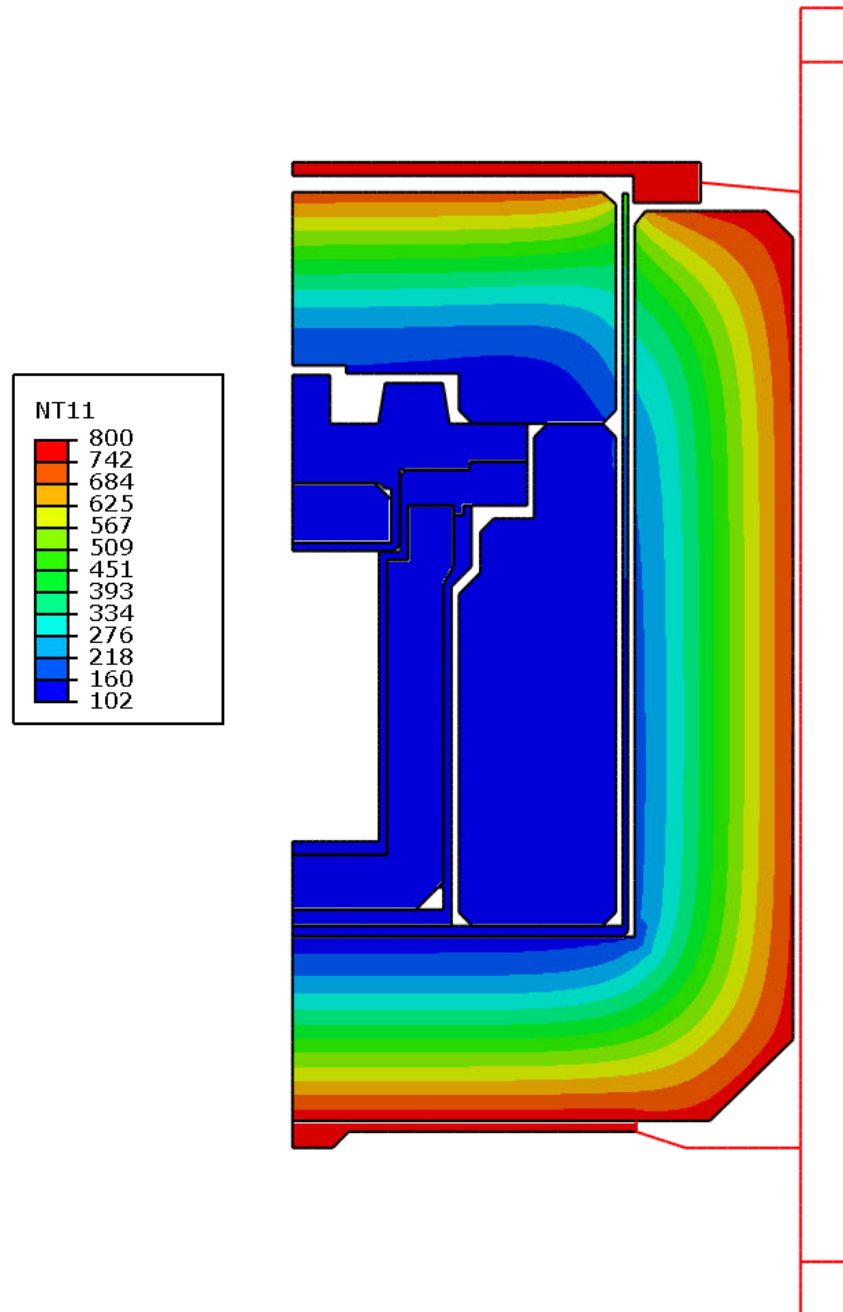

Figure 3-10 Predicted Temperature Profile at the end of the Heating Phase of the Fire Accident

Figure 3-10 and Figure 3-11 show the predicted temperature of the inner containment vessel. The lid seal reaches a maximum temperature of 183°C after 3¾ hours. A similar maximum temperature is experienced by the lead shielding. The lead therefore remains well below its solidus of 252°C. Figure 3-6 shows the maximum temperatures throughout the package under HAC.

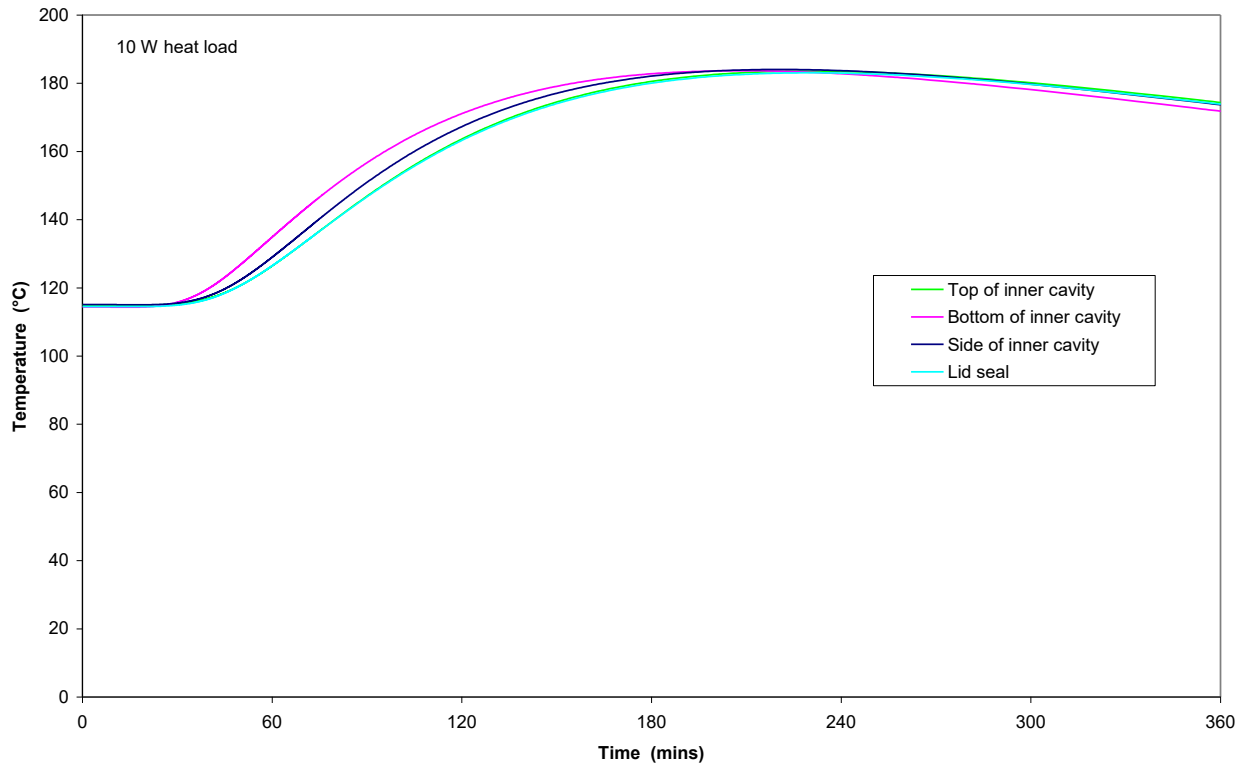

Figure 3-11 Predicted Temperature of the Containment Vessel during the Fire Test

The Design Pressure of the CV is 10 bar (1,000 kPa) gauge.

For solid contents emitting 10W, under HAC the maximum temperature of the CV is 184°C and the maximum temperature of the Shielding Insert and air within the CV is 196°C. Assuming the content were loaded at -40°C and a pressure of 1 bar abs, the pressure at the maximum temperature of the Shielding Insert, calculated according to Boyle's and Charles' Laws of 196°C, would be 2 bar (200 kPa) gauge (see Calculation Sheet CS 2009/08 in section 2.12.2), which is well within the design envelope.

The temperatures reached are within the bounding conditions for the package which are as follows:

HAC Operating Condition	CV
Assumed Max. Temperature	200°C
Max. Pressure	10 bar (1,000kPa) gauge 11 bar (1,100kPa) abs
Min. Temperature	-40°C
Min. Pressure	-1 bar (-100 kPa) gauge 0 bar (0 kPa) abs

3.4.4 Maximum Thermal Stress

As discussed in section 2.7.4.3 the NCT heat calculations bound the HAC test results. The resulting stresses from the NCT heat results are discussed in section 2.6.1.3 and 2.6.1.4. All the stresses calculated are within the allowable limits for the containment vessel.

3.4.5 Accident Conditions for Fissile Material Packages for Air Transport [71.55(f)]

Not applicable – air shipment of fissile material is not specified.

3.5 Appendix

3.5.1 References

- [3.1] American Society of Mechanical Engineers (ASME) Boiler and Pressure Vessel Code, Section II, Part D, 2001 Edition
- [3.2] Design Manual for Structural Stainless Steel (Second edition), The Steel Construction Institute, Building series, Vol 3
- [3.3] Edwards A.L, 'For Computer Heat-Conduction Calculations a Compilation of Thermal Properties Data', UCRL-50589, 1969
- [3.4] Goodfellows data sheet, <http://www.goodfellow.com/AntimonialLead.html>
- [3.5] The Equilibrium Diagram of the System Lead-Tin, London Institute of Metals, 1951
- [3.6] CRC, Handbook of Chemistry and Physics, 75th Edition, 1994-1995 CRC Press
- [3.7] Summary of the Physical Properties and Composition of Resin Bonded Cork, CTR 2001/11, Issue D, 2002
- [3.8] Atomic Energy Technical Data Sheets – Properties of Substances in SI units, UDC 53.
- [3.9] Touloukian & DeWitt, Thermal Radiative Properties – Metallic elements and alloys, Thermophysical properties of matter, Vol 7, Pub IFI/PLENUM, 1970
- [3.10] Title 10, Code of Federal Regulations, Part 71, Office of the Federal Register, Washington, DC, 2009
- [3.11] 'The Emissivity of Various Materials Commonly Encountered in Industry', Land pyrometers Technical Note 101
- [3.12] Parker Hannifin Corporation, Parker O-ring Handbook, ORD 5700/USA, 2001
- [3.13] Abaqus version 6.8-1, Dassault Systemes Simulia Corp
- [3.14] 'Advisory Material for the IAEA Regulations for the Safe Transport of Radioactive Material', 2005 Edition, IAEA Safety Guide No. SSG-26 (Rev. 1), 2018 Edition

3.5.2 Supporting Documents

Document Reference	Title
SERCO/TAS/5388/001 (ETR 318)	Thermal Analysis of the SAFKEG LS Design
SERCO CJF10302 (ETR 575)	Response to comments on thermal performance of SAFKEG LS raised by NRC assessor
CS 2010-16	SAFKEG-LS # 3979A – Maximum temperature of CV inserts
CTR 2021/22	3979A O-ring NCT Test Temperature Reduction - SARP Impact
CTR 2021/24	LS 3979A (3980) O-ring Seal Thermal Tests

(Croft [External Technical Report](#) reference)

4 Containment Evaluation

Contents

4	Containment Evaluation	4-1
4.1	Description of the Containment System [71.33 (a)(4)]	4-1
4.2	Containment Under Normal Condition of Transport (NCT) [71.51 (a)(1)]	4-4
4.2.1	Maximum internal pressures under NCT	4-4
4.2.2	NCT Containment Criterion	4-4
4.2.3	Structural Performance under NCT	4-4
4.2.4	Containment of Radioactive Material under NCT	4-5
4.3	Containment Under Hypothetical Conditions (HAC) [71.51 (a)(2)]	4-5
4.3.1	Maximum internal pressures under HAC	4-5
4.3.2	HAC Containment Criterion	4-5
4.3.3	Structural Performance under HAC	4-5
4.3.4	Containment of Radioactive Material under HAC	4-6
4.3.4.1	Containment of solidcontents	4-6
4.4	Leakage Rate Test for Type B Packages	4-6
4.4.1	Fabrication Leak Rate Test	4-6
4.4.2	Maintenance Leak Rate Test	4-6
4.4.3	Periodic Leak Rate Test	4-6
4.5	Appendix	4-7
4.5.1	References	4-7
4.5.2	Supporting Documents	4-7

Introduction

The containment boundary of the Safkeg-LS 3979A package is identified and discussed in this chapter. The design, materials selected and the method of fastening are discussed with regards to meeting the containment requirements during the operation of the package. The ability of the package to provide the required containment during Normal Conditions of Transport (NCT) and Hypothetical Accident Conditions (HAC) as defined in 10 CFR 71.71 and 10 CFR 71.73 [4.1] respectively is presented. The criteria that verify the containment requirements during fabrication, maintenance and use are presented within this section.

4.1 Description of the Containment System [71.33 (a)(4)]

The containment boundary of the Safkeg-LS 3979A package is formed from the containment vessel flange/cavity wall, lid top and containment seal O-ring, as shown in Figure 4-1. The lid top is sealed to the flange/cavity wall by the containment seal O-ring which is fitted in a face seal configuration with the O-ring recessed into the flange.

A shielded plug is welded with a circumferential weld to the lid top to provide radiation shielding. Although this weld is present in the containment boundary it's function is to hold the lead shielding in position not to fulfill any containment requirement. Indeed complete failure of the weld would not affect containment.

The lid top is held in position with 8 alloy steel closure screws which screw into the containment vessel flange/cavity wall and lid and are tightened to a torque of 10 ± 0.5 Nm. On tightening the

closure screws a uniform and repeatable compression of the O-rings is provided. The closure screws are recessed into the lid top to physically protect them from damage. There is also a shear lip in the lid top and flange protecting the screws from shear failure due to transverse impact loads. The closure screws are positive fasteners, that cannot be opened unintentionally, or by any pressure that may arise within the package.

There are no valves or pressure relief devices present in the containment boundary and the package does not rely on any filter or mechanical cooling system to meet the containment requirements.

The containment system is designed and fabricated in accordance with the applicable sections of ASME B&PV Code Section III, Subsection NB [4.2] as shown in Table 2-8. The complete specifications such as closure screw torques, materials of construction, O-ring specifications and design dimensions for the containment system are given in drawings 1C-6044 (or 1C-9012), 1C-6045 (or 1C-9013) and 1C-6046 (or 1C-9014) in Section 1.3.3.

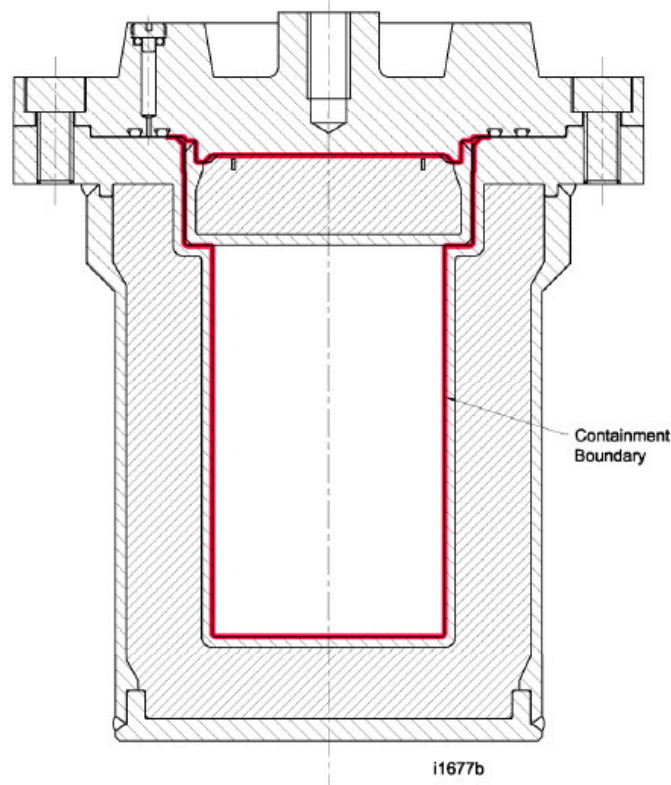

Figure 4-1 Package Containment Boundary

The flange/cavity wall and lid top are machined from solid stainless steel 304L. The containment O-ring is manufactured from Ethylene Propylene rubber. The materials of construction of the containment system are evaluated in Section 2.2.2. All the materials have been selected for compatibility with each other, the inserts and the payload, in order to avoid chemical, galvanic or other reactions.

Ethylene Propylene rubber was selected as the containment O-ring material as it offers a temperature range of -40°C to 150°C and is able to withstand short excursions to 200°C for 2 hours [4.3]. Additionally a Sandia National Laboratories test program [4.4] compared several elastomeric O-ring compounds for performance under transportation package conditions and reported that EP O-rings perform well at both low and high temperatures.

The radiation dose to the containment seal, assuming that the package is loaded with maximum contents as specified in Section 1.2.2 for a full year, is estimated to be $> 10^4$ Gy (10^6 rad). This estimate is based on the dose rate data presented in Section 5.5.4.1.1 for Ir-192 contents. It is judged that Ir-192 would produce the highest dose rate to the containment seal (which is outside the shielding) as it has a penetrating radiation. The maximum dose rate at the containment seal for each of the three inserts specified in Section 1.2.2 for the maximum Ir-192 contents, limited by the package maximum allowable surface dose rate, is given in Table 4-1.

Table 4-1 Safkeg-LS - Dose rate at the containment seal - based on Ir-192

Contents	CT-1				CT-2				CT-3			
	Insert				Insert				Insert			
	Source		Dose rate at containment seal		Source		Dose rate at containment seal		Source		Dose rate at containment seal	
			Sv/h	R/h			Sv/h	R/h			Sv/h	R/h
Calculated dose rate (1)	1000	Ci	1.46E-02	1.46E+00	1000	Ci	3.05E-01	3.05E+01	1000	Ci	3.43E+02	3.43E+04
Package limit	2.58E+01	Ci			1.16E+01	Ci			5.68E-01	Ci		
Dose rate for CT limit			3.77E-04	3.77E-02			3.54E-03	3.54E-01			1.96E-01	1.96E+01
			Sv	R								
Dose in 1 year	8760	hrs	3.30E+00	3.30E+02			3.10E+01	3.10E+03			1.71E+03	1.71E+05

Notes:

(1) From Table 5-3, Section 5.4.4.1.1

The containment O-ring seal is EP which has good radiation resistance with compression set of $<30\%$ at an absorbed radiation level of 10^5 Gy (10^7 rad) whereas the maximum recommended compression set in the Parker Handbook is specified as 40% [4.3]. Furthermore, the Parker Handbook reports that "Practically all elastomers suffer no change of their physical properties at radiation levels up to 10^6 rad". It is concluded that the containment O-ring seal will not be unduly affected by the radiation from the contents of the package. It is noted that the containment O-ring seal is required to be replaced during the periodic maintenance activity (Section 8.2) therefore the O-ring will only be in use for a maximum period of 1 year.

Figure 4-2 shows the two additional O-ring seals fitted to the CV: a test point seal and a test seal. These seals are present to facilitate the leak test of the containment seal during the pre-shipment leak test. The test point is a tapped hole that allows connection of a pressure drop leak tester to the interspace volume between the test seal and the containment seal. The test seal is located close to the containment seal to provide a small interspace volume thus increasing the sensitivity of the pressure rise leakage test. The inserts as specified in Section 1.2.2 are also fitted with an O-ring seal. The test point seal, the test seal and the insert seal are not relied upon for containment.

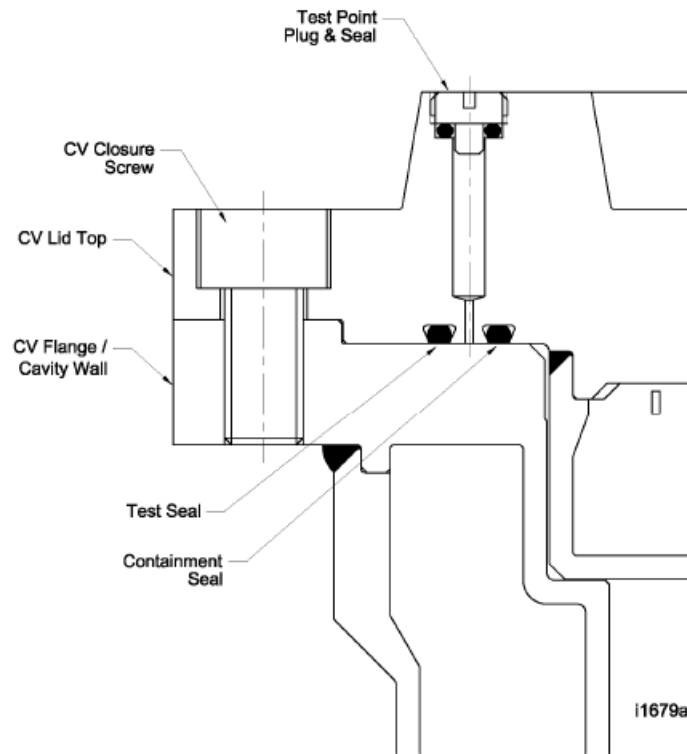

Figure 4-2 Leak Test Seal Arrangement

4.2 Containment Under Normal Condition of Transport (NCT) [71.51 (a)(1)]

4.2.1 Maximum internal pressures under NCT

The maximum internal pressure of the containment vessel under NCT is taken as the design pressure of 7 bar gauge (see Section 3.3.2).

4.2.2 NCT Containment Criterion

The Safkeg-LS 3979A package has been designed specifically to meet the criteria for leaktight during NCT and to be testable to demonstrate that the CV containment boundary is leaktight for the design, testing, fabrication, and maintenance leak tests. Leaktight is defined as demonstration of a leakage rate of $\leq 10^{-7}$ ref.cm³/s as specified in ANSI N14.5 [4.5].

The contents are carried within inserts as specified in Section 1.2.2 which are required for all contents.

Under NCT the shielding inserts provide confinement of the radioactive material (solid or gas). Thus the shielding calculations are based on the contents being retained within the insert specified for the particular contents. However, containment is provided by the containment seal in the CV.

4.2.3 Structural Performance under NCT

The structural performance of the containment boundary of the CV has been demonstrated by prototype testing and analysis.

A prototype Safkeg-LS 3979A package was subjected to the NCT and HAC tests, as reported in Sections 2.6 and 2.7, in an uninterrupted test series, the containment seals were shown to be leaktight on conclusion of the tests.

The structural analysis reported in Sections 2.6 and 2.7 showed that there would be no permanent deformation of any of the containment system components under NCT conditions.

4.2.4 Containment of Radioactive Material under NCT

The structural performance of the containment boundary of the CV has been demonstrated by prototype testing and analysis.

A prototype Safkeg-LS 3979A package was subjected to the NCT and HAC tests, as reported in Sections 2.6 and 2.7, in an uninterrupted test series. Following the tests, the containment vessel was leakage tested in accordance with ANSI N14.5 and the containment system seals were found to be leaktight (having a leakage rate of $\leq 10^{-7}$ ref.cm³/s).

The structural analysis reported in Sections 2.6 and 2.7 showed that there would be no permanent deformation of any of the containment system components under NCT, therefore there would be no effect which could cause any reduction in the effectiveness of the containment system.

4.3 Containment Under Hypothetical Conditions (HAC) [71.51 (a)(2)]

4.3.1 Maximum internal pressures under HAC

The maximum internal pressure of the containment vessel under HAC is taken as the design pressure of 10 bar gauge (see Section 3.3.2).

4.3.2 HAC Containment Criterion

The Safkeg-LS 3979A package has been designed specifically to meet the criteria for leaktight during HAC, and to be testable to demonstrate that the CV containment boundary is leaktight for the design, testing, fabrication, and maintenance leak tests. Leaktight is defined as demonstration of a leakage rate of $\leq 10^{-7}$ ref.cm³/s as specified in ANSI N14.5 [4.5].

The contents are carried within inserts as specified in Section 1.2.2 which are required for all contents.

For solid radioactive material, under HAC the shielding inserts (together with the user defined product containers) provide confinement of the radioactive material within the shielding. Thus the shielding calculations are based on the contents being retained within the insert specified for the particular contents.

For gaseous radioactive material, under HAC the gas is assumed to leak from shielding inserts (and the user defined product containers) and fill the cavity of the CV lid. The gas is assumed to leak from the CV at the containment seal at the leakage rate to which the containment is proved i.e. 10^{-7} ref.cm³/s.

4.3.3 Structural Performance under HAC

The structural performance of the containment boundary of the CV has been demonstrated by prototype testing and analysis.

A prototype Safkeg-LS 3979A package was subjected to the NCT and HAC tests, as reported in Sections 2.6 and 2.7, in an uninterrupted test series. Following the tests, the containment vessel was leakage tested in accordance with ANSI N14.5 and the containment system seals were found to be leaktight (having a leakage rate of $\leq 10^{-7}$ ref.cm³/s).

The structural analysis reported in Sections 2.6 and 2.7 showed that there would be no permanent deformation of any of the containment system components under HAC, therefore there would be no effect which could cause any reduction in the effectiveness of the containment system.

4.3.4 Containment of Radioactive Material under HAC

4.3.4.1 Containment of solid contents

The thermal evaluation in Section 3.4 shows that the bolts and containment system materials do not exceed their temperature limits under HAC. The seals may exceed the operational limits of the O-ring under the HAC conditions, however all batches of O-rings used in the manufacture of the containment vessel will be tested to ensure they can maintain containment under the temperatures experienced during HAC (200°C for 24 hour test as specified in the drawings in section 1.3.3).

The testing and analysis reported in Section 2 show that the containment system would be unaffected by HAC and provide complete containment for all solid contents.

The containment system has been shown to be unaffected by HAC and the seals will be tested to ensure they meet the temperature requirements under HAC: it is therefore concluded that the containment system meets the requirement for providing containment of the solid radioactive contents, within the allowable leakage limits under HAC.

4.4 Leakage Rate Test for Type B Packages

4.4.1 Fabrication Leak Rate Test

The components used to manufacture the containment boundary are required to be helium leak tested during fabrication with a pass rate of 10^{-7} ref.cm³/s. These tests ensure that the fabricated components, meet the required level of containment prior to the approval of the package for use.

The requirements for the fabrication leak rate test are specified in Section 8.1.4.

4.4.2 Maintenance Leak Rate Test

If any maintenance activities are undertaken on the containment boundary, a helium leak rate test is required to confirm that any repairs or replacements have not degraded the containment system performance. The required leak rate has a pass rate of $\leq 10^{-7}$ ref.cm³/s.

The requirements for the periodic leak rate test are specified in Section 8.2.2.

4.4.3 Periodic Leak Rate Test

A periodic helium leak rate test is required to be carried out annually with a pass rate of $\leq 10^{-7}$ ref.cm³/s. This test confirms that the containment boundary capabilities have not deteriorated over an extended period.

The requirements for the maintenance leak rate test are specified in Section 8.2.2.

4.5 Appendix

4.5.1 References

- [4.1] Title 10, Code of Federal Regulations, Part 71, Office of the Federal Register, Washington D.C.
- [4.2] ASME III Division 1 – Subsection NB, Class One Components, Rules for Construction of Nuclear Facility Components, ASME Boiler and Pressure Vessel Code, 2001 edition, the American Society of Mechanical Engineers, New York, New York
- [4.3] Parker Hannifin Corporation, Parker O Ring Handbook, ORD 5700/USA, 2001
- [4.4] Bronowski, D. R., Performance Testing of Elastomeric Seal Materials Under Low- and High-Temperature Conditions: Final Report, SAND94-2207, Sandia National Laboratories, June 2000
- [4.5] ANSI N14.5, American National Standard for Radioactive Materials - Leakage Test on Packages for Shipment, American National Standards Institute, Inc., 1997

4.5.2 Supporting Documents

Document Reference	Title
CS 2009/06	SAFKEG-LS # 3979A - CV seal leak size for leaktight condition
CS 2009/07	SAFKEG-LS 3979A - Gas contents limit for leaktight condition

5 Shielding Evaluation

Contents

5	Shielding Evaluation	5-1
5.1	Description of Shielding Design	5-2
5.1.1	Design Features	5-2
5.2	Summary Table of Maximum Radiation Levels	5-5
5.2.1	Inserts 3984 and 3986	5-5
5.2.2	Insert 3983	5-6
5.3	Source Specification [71.33 (b)(1)]	5-6
5.3.1	Gamma Source	5-6
5.3.2	Neutron Source	5-7
5.4	Shielding Model	5-7
5.4.1	Configuration of Source and Shielding	5-7
5.4.1.1	Model for Monte Carlo calculations for reference case (Ir-192)	5-7
5.4.1.2	Model for MicroShield calculations for Solid Contents	5-7
5.4.2	Material Properties	5-7
5.5	Shielding Evaluation	5-7
5.5.1	Methods	5-7
5.5.2	Input and Output Data	5-7
5.5.3	Flux to Dose Rate Conversion	5-8
5.5.4	External Radiation Levels	5-8
5.5.4.1	Monte Carlo calculations	5-8
5.5.4.1.1	Monte Carlo calculations for reference case (Ir-192)	5-8
5.5.4.2	MicroShield calculations – Inserts 3984 and 3986	5-9
5.5.4.3	Monte Carlo calculations – Inserts 3983	5-11
5.6	Appendix	5-26
5.6.1	References	5-26
5.6.2	Supporting Documents	5-26

Introduction

This section of the application identifies the principal radiation shielding design features of the packaging that are important to safety and provides the results of analysis that shows the packaging meets the shielding requirements of the regulations.

Three assessments are reported:

- A report by Serco (), which is employed to identify the worst case dose point location using a 1kCi Ir-192 source and Monte Carlo code (which is referred to as the 'reference case')

- Croft reports CTR 2009/22 and CTR 2015/10, based on Microshield calculations, which are employed to identify the allowable activity limits based on shielding. These currently only apply to inserts 3984 and 3986.
- Cerberus report C.02086-CROFT-PACK-B02-C01-I1 (ETR 566), which addresses the dose rates for insert 3983, addressing an expanded list of permitted nuclides using Monte Carlo code MCNP [5.5] and re-assessing all of the previous contents approved under Revision 8 of this SARP.

5.1 Description of Shielding Design

5.1.1 Design Features

Figure 5-1 shows the gamma shielding present in the Safkeg-LS 3979A package. The materials of construction and dimensions are fully specified in the drawings in Section 1. Beta and Gamma shielding is provided principally by the lead present in the containment vessel body and lid; the steel of the CV provides some additional shielding.

The lead is cast in position inside the stainless steel cladding of the body and the lid. The only gap between the lead and the stainless steel cladding is at the outside cylindrical surface of the lead. For the CV body, the lead shrinks onto the CV cavity wall, leaving no gap while the gap between the lead and the stainless steel cladding at the outside cylindrical surface of the lead is about 0.2 mm wide. There is no axial gap at the lead onto the base of the CV cavity wall and the method of fitting the CV base leaves no gap. For the CV lid, no gap was found on fabrication of the prototype between the lead and the stainless steel cladding at the outside cylindrical surface of the lead. There is no axial gap as the lead is cast into the CV lid shielding casing and machined such that fitting to the CV lid top leaves no gap. Therefore, there are no gaps in the lead shielding of CV, or at the interface of the lead and steel parts that affect the shielding. The containment vessel is designed so that the shielding in the lid and body are stepped to reduce radiation streaming. The upstanding ring on the lid also provides some additional steel shielding to reduce the radiation streaming from the gap between the CV Lid and CV Body.



The contents of the package are defined as everything that is carried within the CV cavity. For all contents, one of the inserts shown in Figure 5-2, Figure 5-3 or Figure 5-4 is used – these are fully specified in Section 1.2.2.2. These inserts provide different amounts of shielding and also provide confinement for all contents under NCT, and confinement for solid contents under HAC.

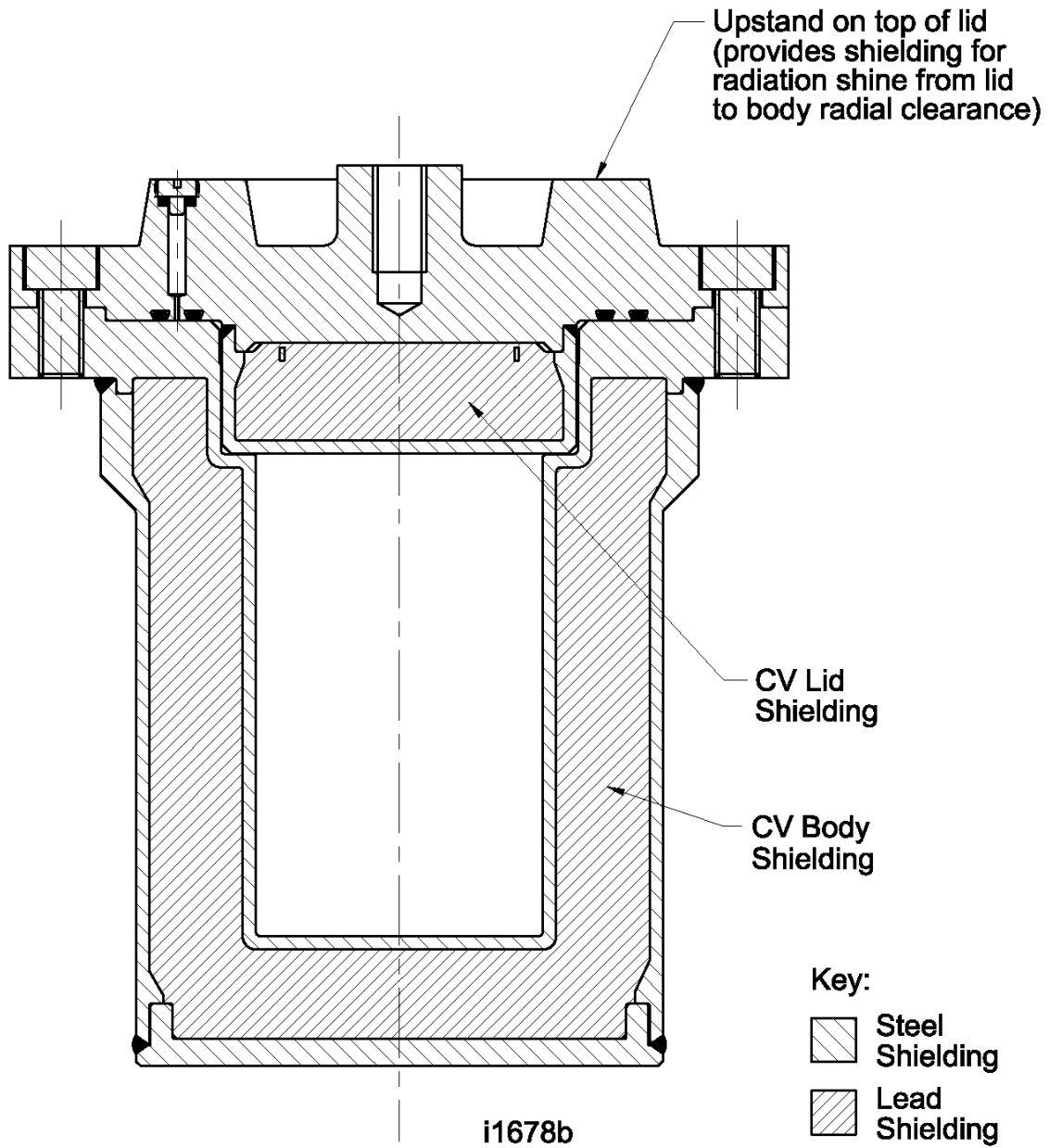

Figure 5-1 Gamma shielding present in the 3979A package

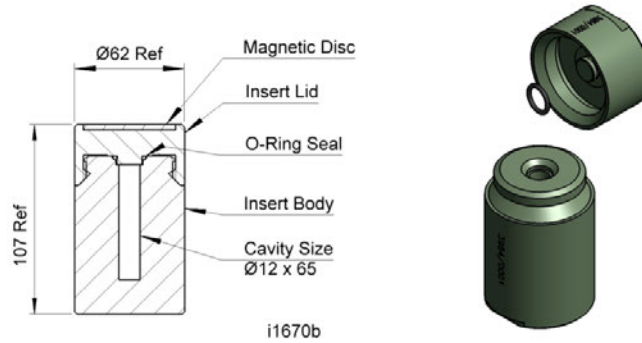

Figure 5-2 Shielding insert LS-12x65-Tu – Design # 3984

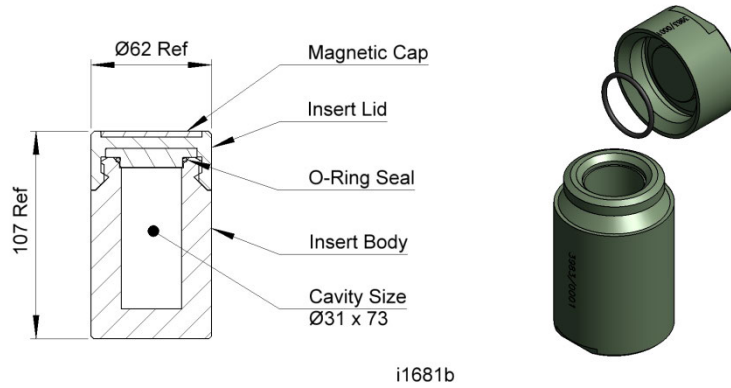

Figure 5-3 Shielding insert LS-31x73-Tu – Design # 3983

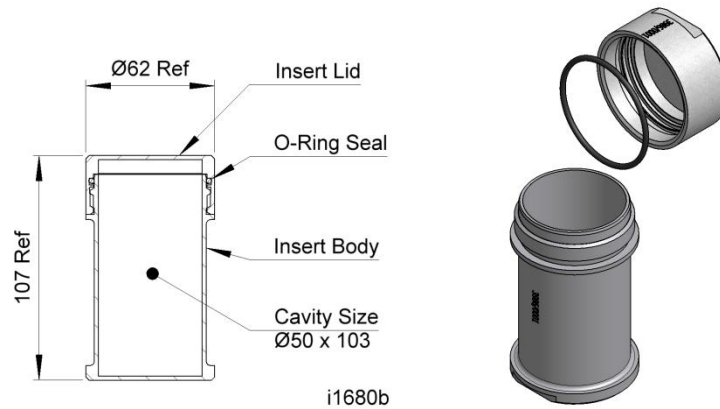

Figure 5-4 Shielding insert LS-50x103-SS – Design # 3986

5.2 Summary Table of Maximum Radiation Levels

5.2.1 Inserts 3984 and 3986

Table 5-1 shows the package maximum NCT dose rates for exclusive use. The maximum quantities of the allowable contents were derived assuming a surface dose rate of 2 mSv/hr. However due to analytical uncertainties, package tolerances and the method of calculation the surface dose rates required increasing in accordance with CTR 2015/10. Therefore the surface dose rates exceeded that of non exclusive use so they were assessed against those of Exclusive use.

Under 10 CFR 71.47(b) if a package exceeds the limits specified in 71.47(a) it shall be shipped under exclusive use and the radiation levels shall not exceed the following during shipment:

- 1) 2 mSv/h (200 mrem/h) on the external surface of the package, unless the following conditions are met, in which case the limit is 10 mSv/h (1000 mrem/h):
 - (i). The shipment is made in a closed transport vehicle;
 - (ii). The package is secured within the vehicle so that its position remains fixed during transportation; and
 - (iii). There are no loading or unloading operations between the beginning and end of the transportation;
- 2) 2 mSv/h (200 mrem/h) at any point on the outer surface of the vehicle, including the top and underside of the vehicle; or in the case of a flat-bed style vehicle, at any point on the vertical planes projected from the outer edges of the vehicle, on the upper surface of the load or enclosure, if used, and on the lower external surface of the vehicle; and
- 3) 0.1 mSv/h (10 mrem/h) at any point 2 meters (80 in) from the outer lateral surfaces of the vehicle (excluding the top and underside of the vehicle); or in the case of a flat-bed style vehicle, at any point 2 meters (6.6 feet) from the vertical planes projected by the outer edges of the vehicle (excluding the top and underside of the vehicle); and
- 4) 0.02 mSv/h (2 mrem/h) in any normally occupied space, except that this provision does not apply to private carriers, if exposed personnel under their control wear radiation dosimetry devices in conformance with 10 CFR 20.1502.

The Safkeg-LS package will be transported in a closed sided truck. The smallest truck that shall be used is an 18 foot (5.5 m) truck. The minimum internal dimensions of this truck are 7'4" (2.24 m) wide and 7' (2.13 m) high. The package shall be secured in position using a transport pallet it shall secure the pallet so that the package is at least 20 cm from the external surface of the base, side and top of the truck.

Within Table 5-1 it has been assumed that the dose rate for each surface is the highest rate calculated. The surface dose rate of the truck has been calculated assuming that the package is only 20 cm from the surface of the truck, therefore accounting for the worst case scenario.

Table 5-1 Summary Table of Maximum Radiation Levels Under Normal Conditions of Transport Under Exclusive Use

Location	Total Gamma + Neutron mSv/h (mrem/h)			10 CFR 71.47(b) Limit
	Top	Side	Bottom	
Package Surface	2.74 (274)	2.74 (274)	2.74 (274)	10 (1000)
Truck Surface	0.4 (40)	0.4 (40)	0.4 (40)	2 (200)

Location	Total Gamma + Neutron mSv/h (mrem/h)			10 CFR 71.47(b) Limit
	Top	Side	Bottom	
2m from Edge of the Truck	0.008 (0.8)	0.008 (0.8)	0.008 (0.8)	0.1 (10)

In practice, the surface dose rate will be less than the calculated dose rates for maximum contents of 2.74 (274) mSv/h (mrem/h) because the assumptions for the calculations as summarized below are inherently conservative.

The MicroShield calculations are based on the following worst case assumptions.

- Self shielding is neglected as the contents are assumed to be a point source.
- The point source is positioned in the worst position (centre of bottom of the Insert) whereas in practice it will usually be a volume distributed throughout a significant part of the cavity.
- Shielding provided by the Product containers is neglected.

5.2.2 Insert 3983

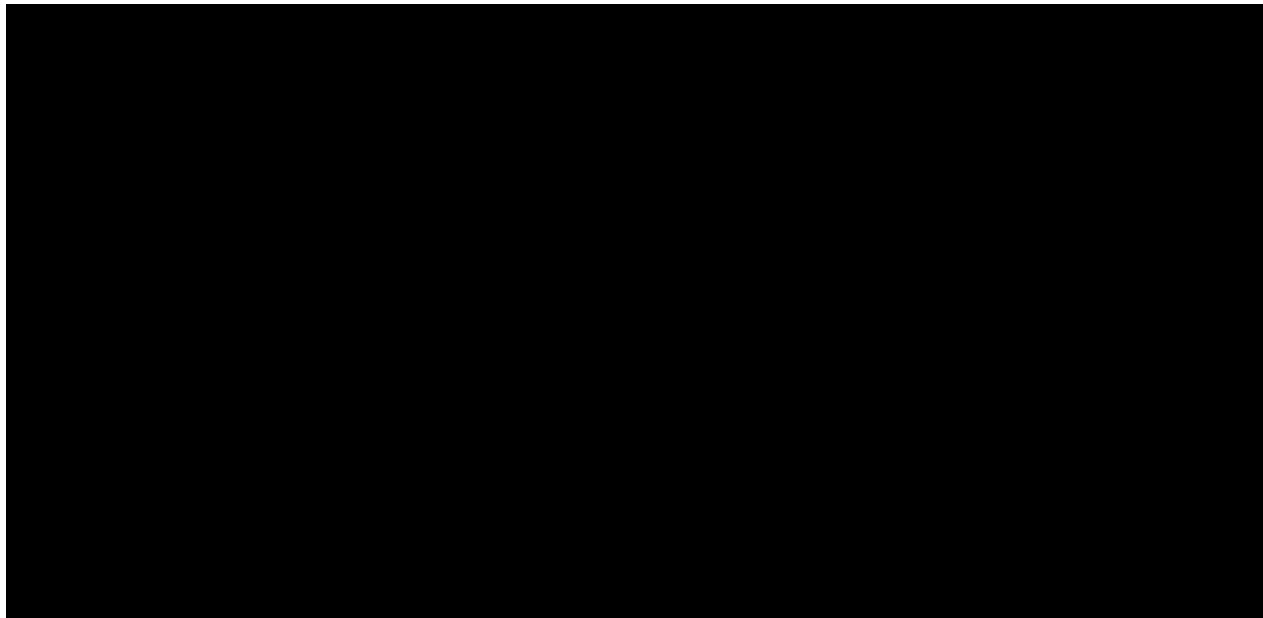

5.3 Source Specification [71.33 (b)(1)]

5.3.1 Gamma Source

For solid and gaseous contents, the source (gamma, beta or alpha according to nuclide) is specified as a point source for all calculations.

Details of source strength for the MicroShield shielding calculations is reported are CTR 2009/22 (Section 5.6.2).

Details of source strength for the Monte Carlo shielding calculations are reported in SERCO/TAS/003191 (ETR 319) and Cerberus report C.02086-CROFT-PACK-B02-C01-I1 (ETR 566) (provided in Section 5.6.2).

5.3.2 Neutron Source

The only contents that emit neutrons are plutonium (limited to solid form).

Details of the source strength are given in report CTR 2009/22 (Section 5.6.2).

5.4 Shielding Model

5.4.1 Configuration of Source and Shielding

5.4.1.1 Model for Monte Carlo calculations for reference case (Ir-192)

For the Monte Carlo calculations, the reference case is for a 1kCi Ir-192 point source positioned all around the surface of the empty CV cavity. This includes a position that lines up with the gap between the CV lid and CV Body. Calculations were also performed with the source in similar positions within the two tungsten inserts (LS-12x65-Tu – Design # 3984, LS-31x73-Tu – Design # 3983).

5.4.1.2 Model for MicroShield calculations for Solid Contents

For the MicroShield shielding calculations reported in CTR 2009/22 (Section 5.6.2), the contents are modeled by a point source positioned at the centre of the bottom of the insert within the CV. The calculations were restricted to the point source at this one position as the Monte Carlo calculations for the reference case (1kCi Ir-192 point source) show that this position produces the higher dose rate on the external surface of the package (see Table 5-2). The MicroShield calculations also include point source calculations for the gaseous contents.

Full details of the configuration of the source are given in the reports referenced above.

Figure 5-5 Not used

5.4.2 Material Properties

The material properties used for the shielding evaluations are given in the reports referenced in Section 5.3.1.

5.5 Shielding Evaluation

5.5.1 Methods

The methods used for the Monte Carlo shielding calculations are reported in SERCO/TAS/003191 for the reference case (Section 5.6.2).

The methods used for the MicroShield shielding calculations for inserts 3984 and 3986 are reported in CTR 2009/22 (Section 5.6.2). This includes the methodology for assessing gamma emitters, beta emitters and neutron emitters.

5.5.2 Input and Output Data

The input and output data for the Monte Carlo reference case shielding calculations are reported in SERCO/TAS/003191 (Section 5.6.2).

The input and output data for the MicroShield shielding calculations, for inserts 3984 and 3986, are reported in CTR 2009/22 (Section 5.6.2).

[REDACTED]

5.5.3 Flux to Dose Rate Conversion

The flux to dose rate conversion data for the Monte Carlo shielding calculations reported in SERCO/TAS/003191 (Section 5.6.2) are taken from ICRP 74 [5.2].

The flux to dose rate conversion data for the MicroShield shielding calculations reported in CTR 2009/22 (Section 5.6.2) are performed by the software using ICRP-51 [5.4], with the Anterior/Posterior values taken as these provided the highest surface dose rate. ICRP 51 provides a lower surface dose rate than using the conversion factors in ANSI/ANS 6.6.1-1977. Therefore a correction factor was applied to the results as detailed in CTR 2015/10. These now only apply to inserts 3984 and 3986, a separate assessment has been performed on the 3983 insert.

[REDACTED]

5.5.4 External Radiation Levels

5.5.4.1 Monte Carlo calculations

5.5.4.1.1 Monte Carlo calculations for reference case (Ir-192)

The results of the Monte Carlo shielding calculations reported in SERCO/TAS/003191 (Section 5.6.2) for the reference case of 1kCi Ir-192 point source, with the source positioned all around the surface of the CV, are presented in Table 5-2 (surface radiation levels) and Table 5-3 (Radiation Levels at 1m from the Surface).

The results showed that the maximum radiation level for each surface was with the source at the centre of the correlating inner surface of the CV cavity – see Table 5-2.

The calculations also provide the dose rate at the seal O-ring position – see Table 5-2.

Table 5-2 Summary Table of External Surface Radiation Levels and Maximum O-ring Dose Rate - Monte Carlo calculations for reference case (Ir-192)

Source position in CV cavity or Insert	External Surface Radiation Levels (mSv/h)		
	No insert	LS-31x73-Tu Design No 3983	LS-12x65-Tu Design No 3984
	(least shielding)	(median shielding)	(most shielding)
Centre at the top of the cavity	9.25E+02	3.29E+01	1.50E+01
Centre at the bottom of the cavity	4.30E+03	1.67E+02	7.72E+01
Centre at side of the cavity	2.82E+03	1.21E+02	2.08E+01
Eccentred at the side of the CV cavity with the source near the	3.29E+03	Not applicable	Not applicable

Source position in CV cavity or Insert	External Surface Radiation Levels (mSv/h)		
	No insert	LS-31x73-Tu Design No 3983	LS-12x65-Tu Design No 3984
	(least shielding)	(median shielding)	(most shielding)
top lined up with the CV Top and Body gaps			
CV O-ring	3.43E+05	3.05E+02	1.46E+02

The highest dose rate at the surface of the package for a point source in all positions within the CV is seen to be with the source at the centre of the bottom of the CV cavity and the highest surface dose rate is at the centre of the bottom of the Outer Keg Shell.

Table 5-3 Summary Table of External Radiation Levels at 1m from the Surface - Monte Carlo calculations for reference case (Ir-192)

Source position in CV cavity or Insert	External Surface Radiation Levels (mSv/h)		
	No insert	LS-31x73-Tu Design No 3983	LS-12x65-Tu Design No 3984
	(least shielding)	(median shielding)	(most shielding)
Centre at the top of the cavity	1.38E+01	5.33E-01	2.40E-01
Centre at the bottom of the cavity	4.22E+01	1.97E+00	9.74E-01
Centre at side of the cavity	5.08E+01	2.57E+00	4.68E-01
Eccentred at the side of the CV cavity with the source near the top lined up with the CV Top and Body gaps	3.29E+01	Not applicable	Not applicable

The dose rate at 1m from the surface of the package for a point source in all positions within the CV is seen to be with the source at the centre of the bottom or side of the CV cavity and the highest surface dose rate is at centre of the bottom or side of the outer Keg Shell respectively.

5.5.4.2 MicroShield calculations – Inserts 3984 and 3986

The results of the MicroShield shielding calculations (reported in CTR 2009/22 and corrected in CTR 2015/10 (Section 5.6.2), consider all of the nuclides to be represented as a point source positioned at the centre of the bottom of each insert, are given in Table 5-4.

Under NCT, it is assumed that gaseous contents are contained in sealed product containers within the applicable insert and that the gaseous contents do not leak from the insert during NCT. Therefore the NCT shielding calculations for gaseous contents are represented by the calculations for a point source positioned at the centre of the bottom of each insert, and the package limits are those given in Table 5-4.

The activities given in Table 5-4 are used to determine the package limit, taking into account mass limit, heat limit, gas limit and shielding limit – see report PCS 036 (see Section 1.3.4).

Table 5-4 Summary Table of External Radiation Levels - MicroShield calculations

Ref #	Nuclide	Activity for Surface Dose of 2.74 mSv/h	
		LS-12x65-Tu – Design # 3984	LS-50x103-SS – Design # 3986
1	Ac-225	1.22E+11	2.08E+10
2	Ac-227	8.38E+11	5.40E+10
3	Ac-228	1.07E+10	1.41E+09
4	Am-241	7.07E+19	1.18E+17
5	As-77	1.95E+14	2.85E+12
6	Au-198	2.33E+12	7.61E+10
7	Ba-131	4.52E+11	2.31E+10
7a	Bi-210		2.74E+10
8	C-14	4.55E+36	1.47E+29
9	Co-60	2.28E+09	3.68E+08
10	Cs-131	4.85E+35	3.59E+35
11	Cs-134	2.24E+10	1.62E+09
12	Cs-137	1.42E+11	5.85E+09
13	Cu-67	4.53E+16	7.67E+13
14	Hg-203	1.06E+19	6.03E+13
15	Ho-166	2.42E+11	4.46E+10
17	I-125	2.61E+35	1.93E+35
18	I-129	4.57E+35	3.38E+35
19	I-131	1.34E+12	5.03E+10
20	In-111	1.38E+22	1.70E+15
21	Ir-192	9.60E+11	2.10E+10
22	Ir-194	2.58E+11	3.35E+10
23	Kr-79	3.34E+11	2.49E+10
24	Lu-177	1.21E+19	1.29E+15
26	Mo-99	2.80E+11	1.70E+10
28	Na-24	7.80E+08	1.79E+08
29	Np-237	6.93E+18	5.02E+18
30	P-32	1.90E+10	2.20E+10
31	P-33	2.37E+23	1.37E+17
32	Pb-203	1.45E+13	5.70E+11
33	Pb-210	3.31E+15	2.39E+14
34	Pd-109	1.17E+15	1.50E+13
34a	Po-210		1.97E+14
35	Pu-238	2.99E+14	2.99E+14
36	Pu-239	6.47E+21	8.26E+20
37	Pu-240	1.15E+13	1.15E+13
38	Pu-241	2.77E+21	4.32E+18
39	Ra-223	8.46E+11	5.46E+10
40	Ra-224	3.33E+09	7.83E+08
41	Ra-226	3.62E+09	6.81E+08
42	Re-186	1.38E+14	6.93E+12
43	Re-188	5.74E+11	6.02E+10
44	Rh-105	1.69E+17	1.48E+13
45	Se-75	6.39E+14	1.28E+12
47	Sm-153	9.33E+15	3.15E+13
48	Sr-89	1.11E+14	1.06E+13
49	Sr-90	1.62E+13	8.94E+11
50	Tb-161	6.57E+17	1.69E+13
51	Th-227	1.79E+12	1.16E+11
52	Th-228	2.53E+09	5.96E+08
53	Tl-201	1.11E+30	1.16E+25
55	U-235	5.60E+14	3.60E+13

Ref #	Nuclide	Activity for Surface Dose of 2.74 mSv/h	
		Insert LS-12x65-Tu – Design # 3984	LS-50x103-SS – Design # 3986
56	W-187	1.96E+11	8.88E+09
57	W-188	6.02E+11	6.31E+10
58	Xe-133	3.20E+35	1.61E+25
59	Y-90	8.76E+09	6.02E+09

5.5.4.3 Monte Carlo calculations – Inserts 3983

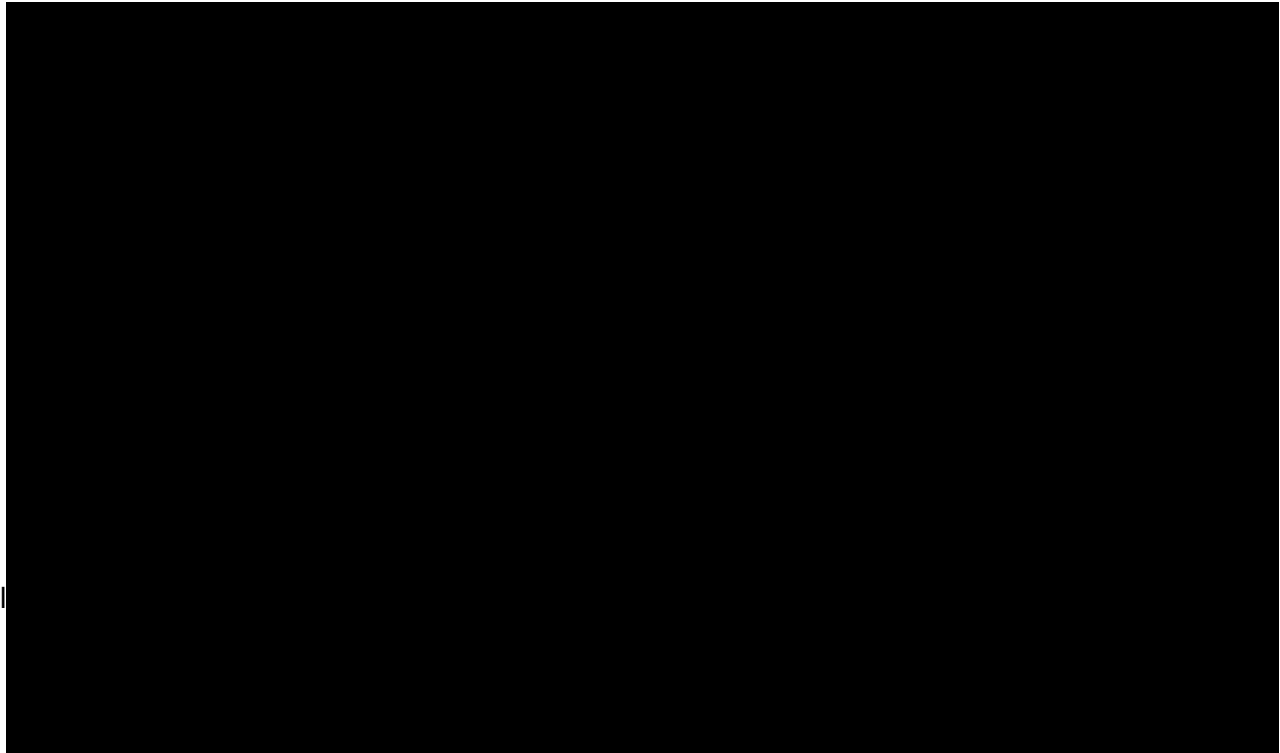

Derivation of the source terms

The source terms for the selected radionuclides were derived using the ORIGEN module of SCALE [5.6], which allows for the derivation of prompt gamma, neutron, alpha-neutron, alpha, beta, and bremsstrahlung gamma source terms for a defined source. In this case, all sources were modelled with an activity of 1kCi, with decay times of 0, 0.5, 1, 7, and 14 days. These decay times take into account any daughter nuclides that may have an effect on the source term. In most cases, this was long enough to reach energetic equilibrium due to the relatively short half-lives of the radionuclides. For those cases where it wasn't, the decay time was extended to determine the most energetic decay time.



Additionally, SCALE cross-checks were run using the MAVRIC module for SCALE [5.6], which simplified the design of the package further such it no longer had slanted edges and was made entirely of cylindrical geometry.

Assessment of the package under normal and accident conditions

As part of normal conditions (NCT), the most conservative source position is at the centre bottom of the insert. Radioactive material will be transported in a product container within the insert when in use, meaning that it will be some distance from the bottom of the insert in normal conditions, so modelling the source at the centre bottom of the insert without a gap is the most pessimistic position. For accident conditions (HAC), it has been assumed that the tungsten insert provides confinement for solid radionuclides. Therefore, as solid radionuclides are modelled in this shielding analysis, the bounding case was to ignore the confinement of any inner/primary product container. It is therefore assumed that the geometry for normal and accident conditions is the same, and that the source position will be varied within the tungsten insert, with additional dose rates measured for the source at the centre middle and top of the insert, as well as 1.5cm radially from the centre for the bottom, middle, and top of the insert. These source positions are illustrated in Figure 5-6.

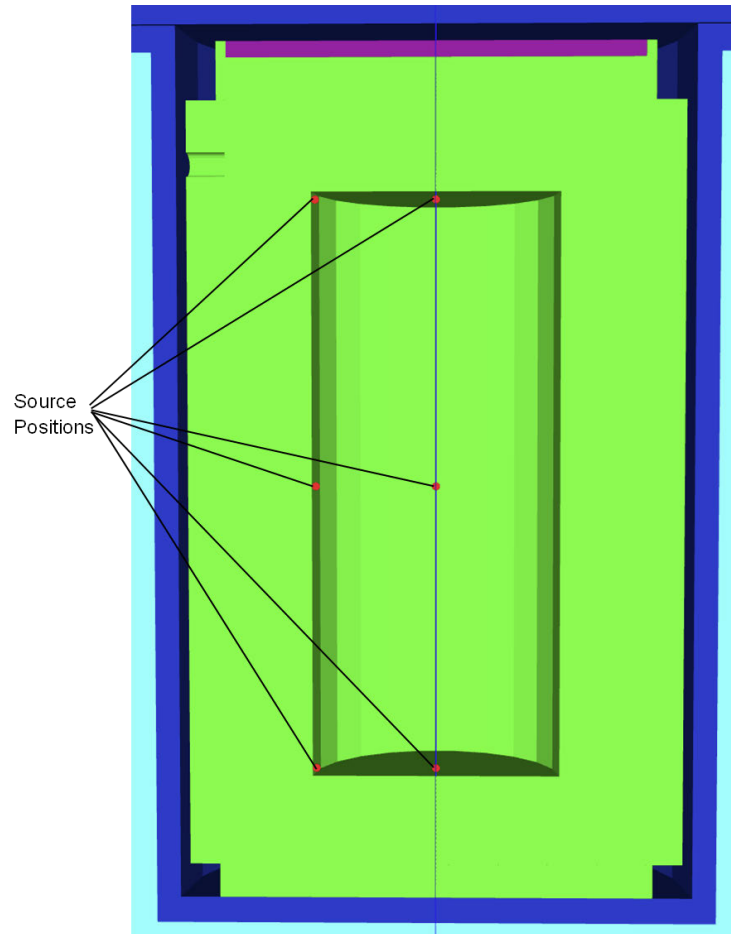

Figure 5-6 Source positions within the 3983 insert

The NCT contact dose limits for these packages are 2mSv/h for non-exclusive use, and 10 mSv/h for exclusive use, with an additional limit of 0.1mSv/h at 1m for non-exclusive use [10]. These are based upon IAEA dose limits and formed the basis of the determination of the limit for each radionuclide. For the ACT, the dose rate limit is 10mSv/h at 1m. The dose rates for gamma, neutron, and alpha-neutron radiation were determined using 1cm³ rectangular volume tallies, with contact tallies touching the outside of the package and additional tallies at 1m from these contact points. For the bremsstrahlung gamma radiation, point tallies were used as beta particles are not compatible with the acceleration technique used for neutron and gamma radiation. The tallies were arranged such that they were aligned with the source position, with the assumed greatest dose rate occurring at the contact tally at the bottom of the vessel. Contact tallies at the side of the package were as illustrated in Figure 5-7.

Only alpha-neutrons and bremsstrahlung gamma dose rates were measured when modelling the radionuclides as an alpha or beta source, because it was assumed that the shielding present in the package would effectively negate any contribution to the dose rate outside the package directly from alpha and beta particles.

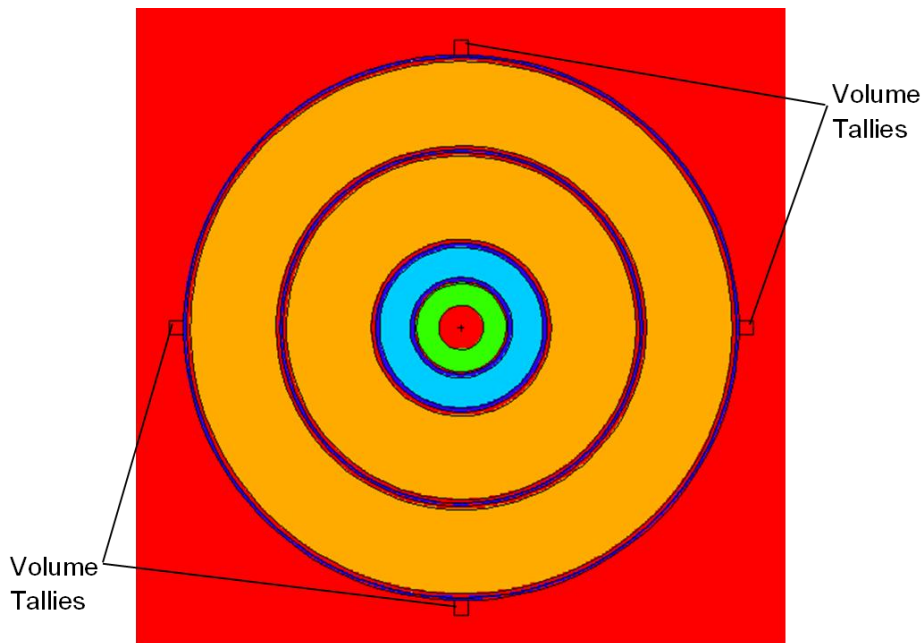
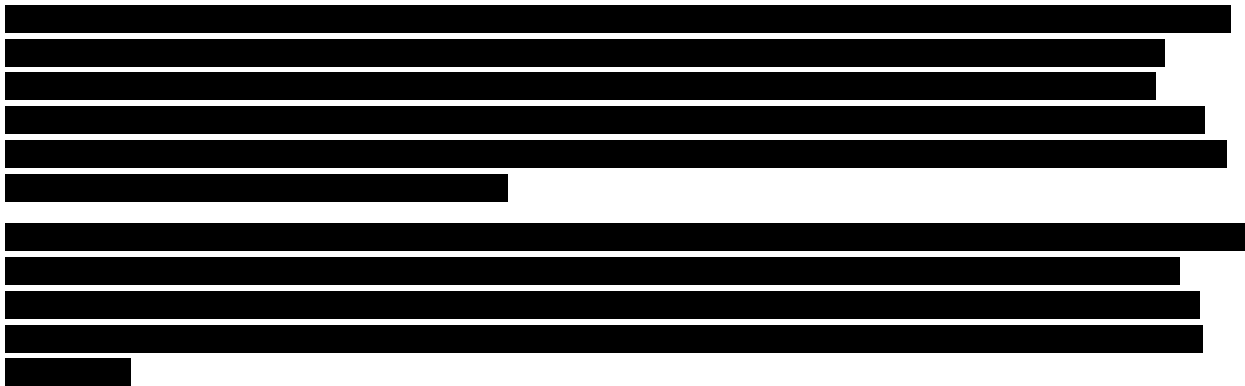

Figure 5-7 : Section view of the model through the z-axis showing the location of the contact volume tallies on the outside of the Keg coincident with source locations

Table 5-5 NCT Activity Limits based on a contact dose rate of 2mSv/h and 10mSv/h respectively

Normal Conditions – Base Contact			TBq Limit (2mSv/h)	
Ref #	Radionuclide	Total Dose / mSv/h/kCi	Non-exclusive	Exclusive
1	Ac-225		7.886E-02	3.943E-01
2	Ac-228		7.378E-03	3.689E-02
3	Au-198		1.487E+00	7.434E+00
4	Ba-131		1.812E-01	9.060E-01
5	Bi-210		1.285E+02	6.424E+02
6	Bi-213		8.008E-01	4.004E+00
7	Cm-244		8.814E-01	4.407E+00
8	Co-60		1.516E-03	7.580E-03
9	Cr-51		8.592E+02	4.296E+03
10	Cs-134		1.252E-02	6.262E-02
11	Cs-137		6.815E-02	3.408E-01
12	Cu-64		3.532E-01	1.766E+00
13	Er-169		3.556E+11	1.778E+12
14	Eu-152		5.063E-03	2.531E-02
15	Eu-154		4.519E-03	2.260E-02
16	Eu-155		2.327E+19	1.163E+20
17	Eu-156		2.833E-03	1.416E-02
18	Fe-55		No Limit	No Limit
19	Fe-59		3.632E-03	1.816E-02
20	Ga-72		1.295E-03	6.476E-03
21	Gd-152		1.183E+05	5.916E+05
22	Gd-153		No Limit	No Limit
23	Hf-177m		1.014E+01	5.069E+01
24	Ho-166		1.494E-01	7.470E-01
25	I-131		4.806E-01	2.403E+00
26	Ir-192		2.848E-01	1.424E+00
27	Ir-194		1.384E-01	6.922E-01
28	La-140		1.494E-03	7.469E-03
29	Lu-176m		4.476E+01	2.238E+02
30	Lu-177m		9.153E+00	4.577E+01
31	Mo-99		1.759E-01	8.793E-01
32	Mo-101		3.152E-03	1.576E-02
33	Mn-54		1.236E-02	6.178E-02
34	Na-24		5.799E-04	2.900E-03
35	Ni-63		No Limit	No Limit
36	P-32		5.082E+00	2.541E+01
37	Pb-203		7.015E+00	3.508E+01
38	Pb-212		4.322E-03	2.161E-02

Normal Conditions – Base Contact			TBq Limit (2mSv/h)	
Ref #	Radionuclide	Total Dose / mSv/h/kCi	Non-exclusive	Exclusive
39	Pd-103		2.217E+04	1.109E+05
40	Ra-224		3.050E-03	1.525E-02
41	Ra-225		1.727E-01	8.636E-01
42	Ra-226		2.600E-03	1.300E-02
43	Ra-227		1.117E+00	5.583E+00
44	Re-188		2.303E-01	1.152E+00
45	Rn-220		2.986E+00	1.493E+01
46	Rn-222		2.778E-03	1.389E-02
47	Sb-122		1.100E-01	5.500E-01
48	Sb-124		2.205E-03	1.102E-02
49	Sc-46		3.272E-03	1.636E-02
50	Sc-47		6.511E+05	3.256E+06
51	Sc-48		1.420E-03	7.098E-03
52	Se-75		4.078E+01	2.039E+02
53	Si-32		9.887E+00	4.944E+01
54	Tc-99m		8.350E+07	4.175E+08
55	Tc-101		7.384E-01	3.692E+00
56	Te-127		5.106E+02	2.553E+03
57	Te-129		4.785E-01	2.393E+00
58	Te-129m		4.173E-01	2.086E+00
59	Te-131		3.425E-02	1.713E-01
60	Te-131m		5.664E-03	2.832E-02
61	Th-227		5.406E-01	2.703E+00
62	Th-228		2.203E-03	1.102E-02
63	Tl-202		3.165E+00	1.583E+01
64	Tl-204		7.395E+03	3.698E+04
65	Tm-168		1.188E-02	5.940E-02
66	Tm-170		6.403E+02	3.202E+03
67	W-187		9.140E-02	4.570E-01
68	W-188		2.541E-01	1.270E+00
69	Y-90		1.113E+00	5.565E+00
70	Yb-169		3.623E+02	1.811E+03
71	Yb-175		6.308E+02	3.154E+03
72	Yb-177		2.902E-02	1.451E-01
73	Zn-65		9.036E-03	4.518E-02
74	Zr-95		2.169E-02	1.084E-01
75	Ac-227		2.508E-01	1.254E+00
76	Am-241		1.405E+02	7.027E+02
77	As-77		3.558E+01	1.779E+02
78	C-14		No Limit	No Limit

Normal Conditions – Base Contact			TBq Limit (2mSv/h)	
Ref #	Radionuclide	Total Dose / mSv/h/kCi	Non-exclusive	Exclusive
79	Cs-131		No Limit	No Limit
80	Cu-67		9.244E+03	4.622E+04
81	Hg-203		1.801E+05	9.003E+05
82	I-125		No Limit	No Limit
83	I-129		No Limit	No Limit
84	In-111		2.257E+08	1.129E+09
85	Lu-177		4.352E+04	2.176E+05
86	Np-237		9.194E-02	4.597E-01
87	P-33		1.037E+19	5.186E+19
88	Pb-210		7.633E+01	3.817E+02
89	Pd-109		8.083E+01	4.042E+02
90	Ra-223		2.525E-01	1.263E+00
91	Re-186		4.402E+01	2.201E+02
92	Rh-105		3.466E+02	1.733E+03
93	Sm-153		7.088E+01	3.544E+02
94	Sr-89		9.059E+00	4.529E+01
95	Sr-90		7.984E-01	3.992E+00
96	Tb-161		4.871E+02	2.436E+03
97	Tl-201		1.010E+14	5.052E+14

Table 5-6 NCT Activity Limits based on a dose rate of 0.1mSv/h at 1m from the surface

Normal Conditions – 1m from Surface			TBq Limit (0.1mSv/h)
Ref #	Radionuclide	Total Dose / mSv/h/kCi	Non-exclusive
1	Ac-225		2.905E-01
2	Ac-228		2.646E-02
3	Au-198		4.874E+00
4	Ba-131		6.167E-01
5	Bi-210		4.200E+02
6	Bi-213		2.972E+00
7	Cm-244		3.567E+00
8	Co-60		5.494E-03
9	Cr-51		2.283E+03
10	Cs-134		4.091E-02
11	Cs-137		2.025E-01
12	Cu-64		1.052E+00
13	Er-169		4.355E+11
14	Eu-152		1.686E-02
15	Eu-154		1.816E-02

Normal Conditions – 1m from Surface			TBq Limit (0.1mSv/h)
Ref #	Radionuclide	Total Dose / mSv/h/kCi	Non-exclusive
16	Eu-155		8.943E+19
17	Eu-156		9.508E-03
18	Fe-55		No Limit
19	Fe-59		1.368E-02
20	Ga-72		4.492E-03
21	Gd-152		4.487E+05
22	Gd-153		No Limit
23	Hf-177m		3.316E+01
24	Ho-166		5.474E-01
25	I-131		1.668E+00
26	Ir-192		9.905E-01
27	Ir-194		5.230E-01
28	La-140		5.312E-03
29	Lu-176m		1.320E+02
30	Lu-177m		1.298E+01
31	Mo-99		6.130E-01
32	Mo-101		1.237E-02
33	Mn-54		4.703E-02
34	Na-24		2.190E-03
35	Ni-63		No Limit
36	P-32		1.971E+01
37	Pb-203		2.091E+01
38	Pb-212		1.548E-02
39	Pd-103		6.848E+04
40	Ra-224		1.081E-02
41	Ra-225		6.118E-01
42	Ra-226		8.696E-03
43	Ra-227		3.595E+00
44	Re-188		8.983E-01
45	Rn-220		1.022E+01
46	Rn-222		1.030E-02
47	Sb-122		4.291E-01
48	Sb-124		7.424E-03
49	Sc-46		1.081E-02
50	Sc-47		1.630E+06
51	Sc-48		5.319E-03
52	Se-75		7.726E+01
53	Si-32		3.448E+01
54	Tc-99m		2.276E+08
55	Tc-101		2.844E+00

Normal Conditions – 1m from Surface			TBq Limit (0.1mSv/h)
Ref #	Radionuclide	Total Dose / mSv/h/kCi	Non-exclusive
56	Te-127		1.597E+03
57	Te-129		1.781E+00
58	Te-129m		1.401E+00
59	Te-131		1.118E-01
60	Te-131m		2.033E-02
61	Th-227		2.077E+00
62	Th-228		8.449E-03
63	Tl-202		9.941E+00
64	Tl-204		1.857E+04
65	Tm-168		4.179E-02
66	Tm-170		1.030E+03
67	W-187		3.031E-01
68	W-188		8.448E-01
69	Y-90		3.970E+00
70	Yb-169		1.255E+03
71	Yb-175		1.387E+03
72	Yb-177		1.094E-01
73	Zn-65		3.160E-02
74	Zr-95		7.827E-02
75	Ac-227		9.138E-01
76	Am-241		5.900E+02
77	As-77		1.152E+02
78	C-14		No Limit
79	Cs-131		No Limit
80	Cu-67		2.315E+04
81	Hg-203		5.508E+05
82	I-125		No Limit
83	I-129		No Limit
84	In-111		1.041E+09
85	Lu-177		1.547E+05
86	Np-237		3.480E-01
87	P-33		1.836E+19
88	Pb-210		2.513E+02
89	Pd-109		3.032E+02
90	Ra-223		8.125E-01
91	Re-186		1.517E+02
92	Rh-105		1.214E+03
93	Sm-153		2.409E+02
94	Sr-89		3.285E+01
95	Sr-90		4.067E+00

Normal Conditions – 1m from Surface			TBq Limit (0.1mSv/h)
Ref #	Radionuclide	Total Dose / mSv/h/kCi	Non-exclusive
96	Tb-161	2.231E-03	1.658E+03
97	Tl-201	8.836E-15	4.187E+14

Table 5-7 HAC Activity limits based on a dose rate of 10mSv/h at 1m from the surface

Accident Conditions (HAC)			Based on 10mSv/h at 1m
Ref #	Radionuclide	Total Dose / mSv/h/kCi	TBq Limit
1	Ac-225		2.290E+01
2	Ac-228		2.203E+00
3	Au-198		4.053E+02
4	Ba-131		4.741E+01
5	Bi-210		3.023E+04
6	Bi-213		2.188E+02
7	Cm-244		3.322E+02
8	Co-60		4.420E-01
9	Cr-51		1.543E+05
10	Cs-134		3.362E+00
11	Cs-137		1.500E+01
12	Cu-64		1.022E+02
13	Er-169		5.424E+12
14	Eu-152		1.373E+00
15	Eu-154		1.300E+00
16	Eu-155		9.484E+20
17	Eu-156		8.779E-01
18	Fe-55		No Limit
19	Fe-59		1.199E+00
20	Ga-72		3.792E-01
21	Gd-152		4.051E+07
22	Gd-153		No Limit
23	Hf-177m		1.710E+03
24	Ho-166		4.590E+01
25	I-131		1.385E+02
26	Ir-192		6.170E+01
27	Ir-194		3.664E+01
28	La-140		4.708E-01
29	Lu-176m		9.987E+03
30	Lu-177m		1.298E+03
31	Mo-99		3.565E+00
32	Mo-101		4.980E+01

Accident Conditions (HAC)			Based on 10mSv/h at 1m
Ref #	Radionuclide	Total Dose / mSv/h/kCi	TBq Limit
33	Mn-54		9.761E-01
34	Na-24		1.925E-01
35	Ni-63		No Limit
36	P-32		1.345E+03
37	Pb-203		1.683E+03
38	Pb-212		1.436E+00
39	Pd-103		6.247E+06
40	Ra-224		9.366E-01
41	Ra-225		5.201E+01
42	Ra-226		8.043E-01
43	Ra-227		2.802E+02
44	Re-188		6.775E+01
45	Rn-220		8.469E+02
46	Rn-222		8.060E-01
47	Sb-122		2.896E+01
48	Sb-124		6.869E-01
49	Sc-46		9.622E-01
50	Sc-47		1.092E+08
51	Sc-48		3.905E-01
52	Se-75		6.863E+03
53	Si-32		2.777E+03
54	Tc-99m		1.498E+10
55	Tc-101		2.134E+02
56	Te-127		1.024E+05
57	Te-129		1.384E+02
58	Te-129m		1.137E+02
59	Te-131		1.114E+01
60	Te-131m		1.630E+00
61	Th-227		1.609E+02
62	Th-228		7.323E-01
63	Tl-202		7.420E+02
64	Tl-204		7.167E+05
65	Tm-168		3.565E+00
66	Tm-170		7.951E+04
67	W-187		2.711E+01
68	W-188		7.545E+01
69	Y-90		2.496E+02
70	Yb-169		8.833E+04
71	Yb-175		1.353E+05
72	Yb-177		8.564E+00

Accident Conditions (HAC)			Based on 10mSv/h at 1m
Ref #	Radionuclide	Total Dose / mSv/h/kCi	TBq Limit
73	Zn-65		2.664E+00
74	Zr-95		5.727E+00
75	Ac-227		7.578E+01
76	Am-241		5.511E+04
77	As-77		9.065E+03
78	C-14		No Limit
79	Cs-131		No Limit
80	Cu-67		1.712E+06
81	Hg-203		1.613E+07
82	I-125		No Limit
83	I-129		No Limit
84	In-111		1.917E+10
85	Lu-177		7.564E+06
86	Np-237		3.088E+01
87	P-33		1.633E+19
88	Pb-210		1.805E+04
89	Pd-109		2.060E+04
90	Ra-223		6.138E+01
91	Re-186		1.000E+04
92	Rh-105		6.289E+04
93	Sm-153		1.769E+04
94	Sr-89		2.422E+03
95	Sr-90		2.982E+02
96	Tb-161		1.436E+05
97	Tl-201		4.187E+16

Table 5-8 Exclusive-Use, 0.1mSv/h 2m from package surface

Ref #	Radionuclide	NCT @1m+1m	TBq Limit	Check	From NCT Contact tab, TBq
Ref #	Radionuclide	Total Dose / mSv/h/kCi	Activity Limit for 0.1mSv/h at 2m (Exclusive Use), TBq	Is this greater than NCT Exclusive Use contact activity limit, True/False	From NCT Contact tab, TBq
1	Ac-225		1.041E+00	TRUE	3.94E-01
2	Ac-228		9.477E-02	TRUE	3.69E-02
3	Au-198		1.746E+01	TRUE	7.43E+00
4	Ba-131		2.209E+00	TRUE	9.06E-01
5	Bi-210		1.505E+03	TRUE	6.42E+02
6	Bi-213		1.065E+01	TRUE	4.00E+00

Ref #	Radionuclide	NCT @1m+1m Total Dose / mSv/h/kCi	TBq Limit Activity Limit for 0.1mSv/h at 2m (Exclusive Use), TBq	Check Is this greater than NCT Exclusive Use contact activity limit, True/False	From NCT Contact tab, TBq
7	Cm-244		1.278E+01	TRUE	4.41E+00
8	Co-60		1.968E-02	TRUE	7.58E-03
9	Cr-51		8.178E+03	TRUE	4.30E+03
10	Cs-134		1.466E-01	TRUE	6.26E-02
11	Cs-137		7.252E-01	TRUE	3.41E-01
12	Cu-64		3.769E+00	TRUE	1.77E+00
13	Er-169		1.560E+12	FALSE	1.78E+12
14	Eu-152		6.041E-02	TRUE	2.53E-02
15	Eu-154		6.507E-02	TRUE	2.26E-02
16	Eu-155		3.204E+20	TRUE	1.16E+20
17	Eu-156		3.406E-02	TRUE	1.42E-02
18	Fe-55		No Limit	FALSE	No Limit
19	Fe-59		4.900E-02	TRUE	1.82E-02
20	Ga-72		1.609E-02	TRUE	6.48E-03
21	Gd-152		1.607E+06	TRUE	5.92E+05
22	Gd-153		No Limit	FALSE	No Limit
23	Hf-177m		1.188E+02	TRUE	5.07E+01
24	Ho-166		1.961E+00	TRUE	7.47E-01
25	I-131		5.975E+00	TRUE	2.40E+00
26	Ir-192		3.548E+00	TRUE	1.42E+00
27	Ir-194		1.873E+00	TRUE	6.92E-01
28	La-140		1.903E-02	TRUE	7.47E-03
29	Lu-176m		4.728E+02	TRUE	2.24E+02
30	Lu-177m		4.648E+01	TRUE	4.58E+01
31	Mo-99		2.196E+00	TRUE	8.79E-01
32	Mo-101		4.431E-02	TRUE	1.58E-02
33	Mn-54		1.685E-01	TRUE	6.18E-02
34	Na-24		7.845E-03	TRUE	2.90E-03
35	Ni-63		No Limit	FALSE	No Limit
36	P-32		7.061E+01	TRUE	2.54E+01

i.e. Activity Limit based on 2m limit rather than contact

e.g. No activity limit based on shielding.

Ref #	Radionuclide	NCT @1m+1m Total Dose / mSv/h/kCi	TBq Limit Activity Limit for 0.1mSv/h at 2m (Exclusive Use), TBq	Check Is this greater than NCT Exclusive Use contact activity limit, True/False	From NCT Contact tab, TBq
37	Pb-203		7.492E+01	TRUE	3.51E+01
38	Pb-212		5.547E-02	TRUE	2.16E-02
39	Pd-103		2.453E+05	TRUE	1.11E+05
40	Ra-224		3.873E-02	TRUE	1.52E-02
41	Ra-225		2.192E+00	TRUE	8.64E-01
42	Ra-226		3.115E-02	TRUE	1.30E-02
43	Ra-227		1.288E+01	TRUE	5.58E+00
44	Re-188		3.218E+00	TRUE	1.15E+00
45	Rn-220		3.660E+01	TRUE	1.49E+01
46	Rn-222		3.691E-02	TRUE	1.39E-02
47	Sb-122		1.537E+00	TRUE	5.50E-01
48	Sb-124		2.660E-02	TRUE	1.10E-02
49	Sc-46		3.873E-02	TRUE	1.64E-02
50	Sc-47		5.838E+06	TRUE	3.26E+06
51	Sc-48		1.905E-02	TRUE	7.10E-03
52	Se-75		2.768E+02	TRUE	2.04E+02
53	Si-32		1.235E+02	TRUE	4.94E+01
54	Tc-99m		8.152E+08	TRUE	4.17E+08
55	Tc-101		1.019E+01	TRUE	3.69E+00
56	Te-127		5.721E+03	TRUE	2.55E+03
57	Te-129		6.381E+00	TRUE	2.39E+00
58	Te-129m		5.017E+00	TRUE	2.09E+00
59	Te-131		4.007E-01	TRUE	1.71E-01
60	Te-131m		7.285E-02	TRUE	2.83E-02
61	Th-227		7.441E+00	TRUE	2.70E+00
62	Th-228		3.027E-02	TRUE	1.10E-02
63	Tl-202		3.561E+01	TRUE	1.58E+01
64	Tl-204		6.652E+04	TRUE	3.70E+04
65	Tm-168		1.497E-01	TRUE	5.94E-02
66	Tm-170		3.689E+03	TRUE	3.20E+03
67	W-187		1.086E+00	TRUE	4.57E-01
68	W-188		3.026E+00	TRUE	1.27E+00
69	Y-90		1.422E+01	TRUE	5.57E+00
70	Yb-169		4.496E+03	TRUE	1.81E+03
71	Yb-175		4.968E+03	TRUE	3.15E+03
72	Yb-177		3.920E-01	TRUE	1.45E-01

		NCT @1m+1m	TBq Limit	Check	
Ref #	Radionuclide	Total Dose / mSv/h/kCi	Activity Limit for 0.1mSv/h at 2m (Exclusive Use), TBq	Is this greater than NCT Exclusive Use contact activity limit, True/False	From NCT Contact tab, TBq
73	Zn-65		1.132E-01	TRUE	4.52E-02
74	Zr-95		2.804E-01	TRUE	1.08E-01
75	Ac-227		3.274E+00	TRUE	1.25E+00
76	Am-241		2.114E+03	TRUE	7.03E+02
77	As-77		4.127E+02	TRUE	1.78E+02
78	C-14		No Limit	FALSE	No Limit
79	Cs-131		No Limit	FALSE	No Limit
80	Cu-67		8.293E+04	TRUE	4.62E+04
81	Hg-203		1.973E+06	TRUE	9.00E+05
82	I-125		No Limit	FALSE	No Limit
83	I-129		No Limit	FALSE	No Limit
84	In-111		3.730E+09	TRUE	1.13E+09
85	Lu-177		5.542E+05	TRUE	2.18E+05
86	Np-237		1.247E+00	TRUE	4.60E-01
87	P-33		6.575E+19	TRUE	5.19E+19
88	Pb-210		9.003E+02	TRUE	3.82E+02
89	Pd-109		1.086E+03	TRUE	4.04E+02
90	Ra-223		2.911E+00	TRUE	1.26E+00
91	Re-186		5.435E+02	TRUE	2.20E+02
92	Rh-105		4.348E+03	TRUE	1.73E+03
93	Sm-153		8.629E+02	TRUE	3.54E+02
94	Sr-89		1.177E+02	TRUE	4.53E+01
95	Sr-90		1.457E+01	TRUE	3.99E+00
96	Tb-161		5.940E+03	TRUE	2.44E+03
97	Tl-201		1.500E+15	TRUE	5.05E+14

Table 5-9 Geometry and dimensions employed in Table 5-8

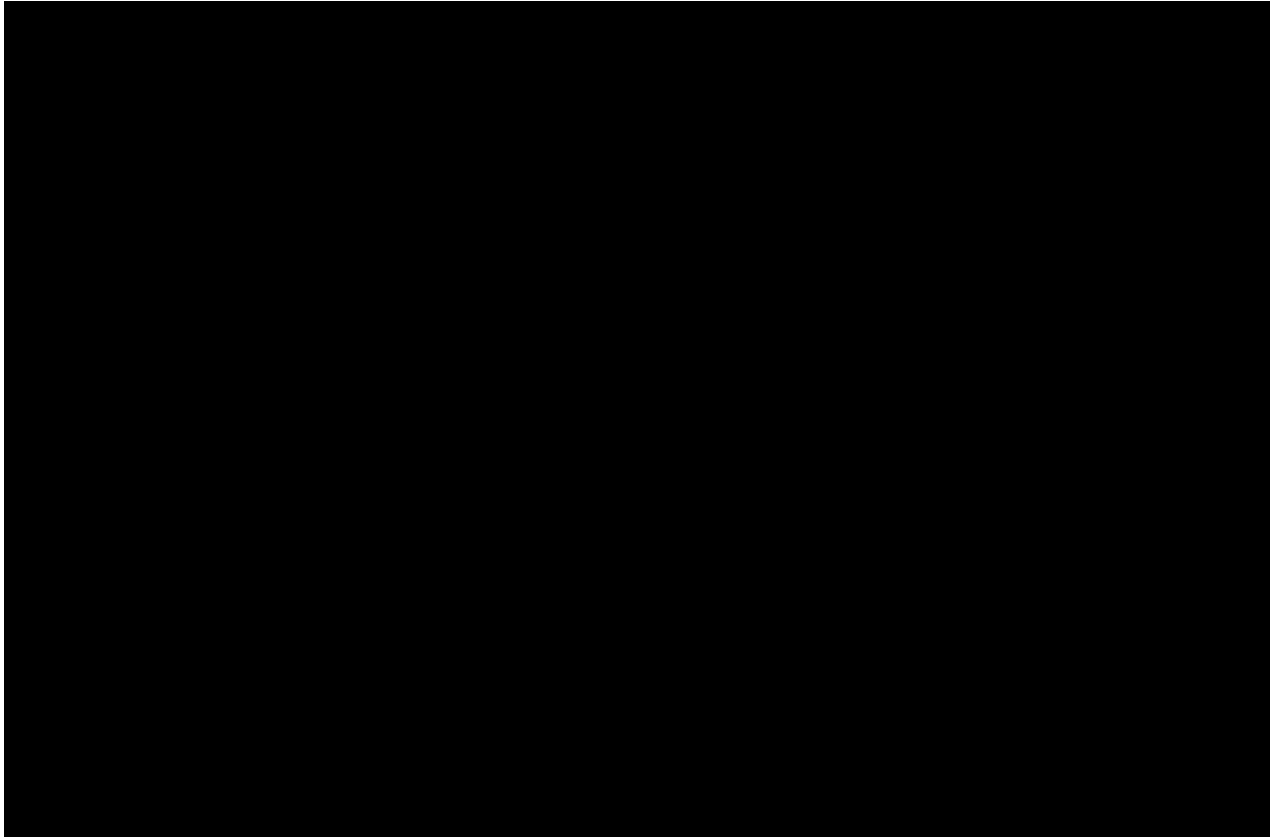

The content of this table is redacted with a large black rectangle.

5.6 Appendix

5.6.1 References

- [5.1] Title 10, Code of Federal Regulations, Part 71, Office of the Federal Register, Washington D.C.
- [5.2] ICRP Publication 74, "Conversion Coefficients for use in Radiological Protection against External Radiation", Annals of the ICRP 26 3/4, 1996
- [5.3] Not Used.
- [5.4] ICRP Publication 51, "Data for Use in Protection against External Radiation", Annals of the ICRP, 1984
- [5.5] Los Alamos National Laboratory, MCNP 6.2, A General-Purpose Monte Carlo N-Particle Radiation Transport Code.
- [5.6] W. A. Wieselquist, R. A. Lefebvre, Eds., SCALE 6.3.1 User Manual, ORNL/TM-SCALE-6.3.1, UT-Battelle, LLC, Oak Ridge National Laboratory, Oak Ridge, TN, 2003
- [5.7] Oak Ridge National Laboratory, ADVANTG - An Automated Variance Reduction Parameter Generator, 2015

5.6.2 Supporting Documents

Document Reference	Title
CTR2009/22	SAFKEG LS 3979A: Package Activity Limits Based on Shielding
CTR2015/10	Uncertainties Associated with the Proposed Shielding Calculation Method for the SAFKEG-LS 3979A Package
SERCO/TAS/003191/001 (ETR 319)	Monte Carlo Modelling of Safkeg LS Container
Cerberus Nuclear C.02086- CROFT-PACK-B02-C01-I1 (ETR 566)	Transport Shielding Assessment for the Croft SAFKEG-LS Package DN 3979 A

(Croft [External](#) [Technical](#) [Report](#) reference)

6 Criticality Evaluation

Contents

6	Criticality Evaluation	6-1
6.1	Description of Criticality Design	6-1
6.2	Fissile Material Contents.....	6-1
6.2.1	Fissile material under Exemption 71.15	6-1
6.2.2	Fissile material under General License 71.22	6-1
6.2.3	Plutonium-beryllium special form material under General License 71.23.....	6-1
6.3	General Consideration	6-2
6.4	Single Package Evaluation	6-2
6.5	Evaluation of Package Arrays under Normal Conditions of Transport	6-2
6.6	Package Array Under Hypothetical Conditions	6-2
6.7	Fissile Material Packages for Air Transport.....	6-2
6.8	Benchmark Evaluations	6-2
6.9	Appendix.....	6-2
6.9.1	References	6-2

Introduction

This section specifies the requirements for fissile contents for the Safkeg-LS 3979A package which are restricted to solids as Contents Type CT-7 as specified in Section 1.2.2 and Table 1-9.

Fissile material in quantities requiring a criticality evaluation, are not to be carried. However, small quantities may be carried under the conditions described below.

6.1 Description of Criticality Design

There are no special features needed or provided for fissile contents

6.2 Fissile Material Contents

The contents are limited to the quantities as specified in the following sections.

6.2.1 Fissile material under Exemption 71.15

Fissile material meeting the requirements of 10CFR 71.15 [6.1] are allowed by virtue of the Exemption provided by this regulation.

Note that the other requirements of CT-7 specified in Section 1.2.2 and Table 1-9 have to be met.

6.2.2 Fissile material under General License 71.22

Fissile material meeting the requirements of 10 CFR 71.22 [6.1] are allowed by virtue of the General License provided by this regulation.

Note that the other requirements of CT-7 specified in Section 1.2.2 and Table 1-9 have to be met.

6.2.3 Plutonium-beryllium special form material under General License 71.23

Plutonium-beryllium special form material meeting the requirements of 10CFR 71.23 [6.1] is included in CT-7 specified in Section 1.2.2 and Table 1-9 on the basis of the General license in 10 CFR 71.23.

Note that the other requirements of CT-7 specified in Section 1.2.2 and Table 1-9 have to be met.

6.3 General Consideration

Not required as the limited quantities of fissile material specified in 10 CFR 71.15, 10 CFR 71.22, 10 CFR 71.23 [6.1] are accepted as not requiring criticality evaluation.

6.4 Single Package Evaluation

Not required as the limited quantities of fissile material specified in 10CFR 71.15, 10 CFR 71.22, 10CFR 71.23 [6.1] are accepted as not requiring criticality evaluation.

6.5 Evaluation of Package Arrays under Normal Conditions of Transport

Not required as the limited quantities of fissile material specified in 10CFR 71.15, 10 CFR 71.22, 10 CFR 71.23 [6.1] are accepted as not requiring criticality evaluation.

6.6 Package Array Under Hypothetical Conditions

Not required as the limited quantities of fissile material specified in 10 CFR 71.15, 10 CFR 71.22, 10 CFR 71.23 [6.1] are accepted as not requiring criticality evaluation.

6.7 Fissile Material Packages for Air Transport

Air transport of plutonium is only allowed for the limited quantities specified in 10 CFR 71.88.

6.8 Benchmark Evaluations

Not applicable.

6.9 Appendix

6.9.1 References

[6.1] Title 10, Code of Federal Regulations, Part 71, Office of the Federal Register, Washington D.C.

7 Package Operations

Contents

7	Package Operations	7-1
7.1	Package loading	7-1
7.1.1	Preparation for Loading	7-2
7.1.2	Loading of Contents	7-3
7.1.3	Preparation for Transport	7-3
7.2	Package Unloading	7-4
7.2.1	Receipt of Package from Carrier	7-4
7.2.2	Removal of Contents	7-4
7.3	Preparation of Empty Packages for Transport	7-5
7.4	Other Operations	7-6
7.5	Appendix	7-6
7.5.1	References	7-6

Introduction

This section specifies the requirements for loading and unloading the Safkeg-LS 3979A package, and preparation of an empty package for transport.

Each packaging user shall load, unload, and prepare the package for transport in accordance with approved operating procedures that ensure compliance with the requirements of Subpart G to 10 CFR Part 71 [7.1] and 49 CFR Parts 171 through 178 [7.2]. They shall ensure that occupational radiation exposures are maintained as low as reasonably achievable as required by 10 CFR 835 [7.3].

Each packaging user shall ensure compliance with the requirements of this safety analysis report and the user's organization with regard to documentation, records, safety, and work procedures. Each user shall have a quality assurance program that meets the requirements of 10 CFR 71 Subpart H and shall maintain records that meet the requirements of 10 CFR 71.91.

If during use any instance is found where there is a significant reduction in the effectiveness of the package, where defects are identified with safety significance after first use or there are instances in which the conditions of approval in the Certificate of Compliance were not observed in making a shipment. Then each packaging user shall first request the certificate holders input regarding the incident and then submit a written report to the Nuclear Regulatory Commission in accordance with 10 CFR 71.95.

All drawings referred to in this section are included in Section 1.3.3 of the SARP.

7.1 Package loading

This section provides the minimum requirements required in order to load the package. From these requirements each organization shall prepare specific instructions and checklists, in accordance with that organization's Quality Assurance Program. This will ensure compliance with the following requirements.

The periodic maintenance activities, as specified in Section 8.2, shall have been performed not more than 1 year prior to shipment.

7.1.1 Preparation for Loading

- 1) The external surface of the package shall be inspected for radioactive contamination, and decontaminated if necessary. All components shall also be checked for contamination, and decontaminated if necessary.
- 2) A survey of the radiation levels of the package shall be conducted to confirm that the package is empty. If, at any stage of disassembly, levels of radiation above that permitted are detected, then the appropriate action shall be taken to safeguard personnel, and to rectify the situation.
- 3) The security seals, padlock (if fitted), closure nuts/washers, lid and top cork shall be removed from the keg.
- 4) The containment vessel shall be removed from within the inner cork. The recommended method for lifting the containment vessel is using a 12 mm eye bolt threaded into the containment vessel lid.
- 5) The containment vessel closure screws and lid shall be removed.
- 6) If the containment vessel lid is not readily released, as may occur if the containment vessel was loaded at a lower atmospheric pressure, gently jack the lid from the containment vessel body using 2 jacking screws fitted in the jacking holes on the containment vessel lid. The jacking screws should be left in the containment vessel lid withdrawn to be flush with the lid top surface.
- 7) The model/serial numbers of the containment vessel assembly (body and lid) shall be checked to ensure they match. Where the model/serial numbers of the containment vessel assembly (body and lid) do not match, these components shall be removed from service and, in accordance with the users NCR (Non Conformance Report) system, the complete packaging shall be subjected to maintenance in accordance with the requirements of Section 8.2.
- 8) The containment vessel body and lid shall be checked for damage that may have occurred during transport. Check the closure screws are in good condition and that no fatigue cracks have developed during transport. Check that the closure components assemble freely by hand. Repair or replace any damaged items.
- 9) The O-rings shall be visually inspected for any cuts, blemishes, debris or permanent local deformation on the sealing surface. Damaged seals shall be replaced with seals meeting the specifications in drawing 1C-6044 (or 1C-9012). If the O-rings are acceptable, lubricate with a light film of silicone O-ring lubricant.
- 10) If the containment seal O-ring is replaced or the containment O-ring has not been leak tested within 12 months prior to the shipment, a helium leak test shall be performed in accordance with Section 8.1.4.

NOTE: Completion of a helium leak test DOES NOT relieve the need to perform the pre-shipment leak test in Section 7.1.3 step 1.

- 11) The model/serial numbers of the keg assembly (keg body and keg lid) shall be checked to ensure they match: where the model/serial numbers of the containment vessel assembly (body and lid) do not match, these assemblies shall be removed from service and, in accordance with the users NCR system, the complete packaging shall be subjected to maintenance in accordance with the requirements of Section 8.2.
- 12) The outer surfaces of the keg body and lid shall be visually inspected for unacceptable defects. Unacceptable defects are dents greater than 8.9 mm in depth, penetration of the keg body, abrasion/scratches greater than half the thickness of the keg shell (the shell thickness is 2mm) or cracks in the accessible welds.
- 13) Check that the keg lid fits without interference with the closure studs. Check that the closure studs and bolts are undamaged i.e. no fatigue cracks have developed and the studs are not

stripped. The closure nuts and studs shall fit up without interference. The keg lid seal shall be fitted into the O-ring groove in the top of the keg. It shall be checked for any visible damage. The keg lid seal (item 13, drawing 0C-6042), closure studs (item 16, drawing 0C-6042), closure nuts/washers (item 14 and 15, drawing 0C-6042) shall be replaced, if missing or damaged.

- 14) Check that the cork packing pieces (inner cork and top cork) are in good condition i.e. intact and not chipped or cracked. Replace as required.
- 15) Remove the keg steel liner and invert the keg to check for the presence of water. If water runs out of the keg. Place the keg minus the liner and lid in a controlled oven and hold the oven at 80°C for 24 hours.

7.1.2 Loading of Contents

- 1) The containment vessel cavity shall be checked to ensure it is dry and clean before loading with the radioactive contents.
- 2) The contents shall be limited as required by Section 1.2.2 of this SARP and the Certificate of Compliance. The contents shall be chemically compatible (i.e. not chemically reactive) with their immediate packaging and the containment boundary (e.g. stainless steel 304L, tungsten, EP O-ring).
- 3) From the contents type to be shipped, determine the insert required for the shipment in accordance with Table 1-2 in Section 1.2.2.3. Visually inspect the insert to be used for the shipment for any damage. Check that the lid screws freely by hand onto the body. If there is any damage or the closure does not operate correctly carry out a maintenance operation according to Section 8.2.3. Check that the O-ring is present, if not it, shall be replaced
- 4) Check that the contents meet the restrictions for its content type as listed in Table 1-3 to Table 1-10 and Table 1-11 to Table 1-18 in Section 1.2.2.3.
- 5) If the content is Special Form, check the Special Form certificate to ensure it is current.
- 6) Load the contents into the insert and fit the insert lid ensuring that it is hand tight and cannot tighten any further. Load the insert into the containment vessel.
- 7) The lid shall be fitted to the containment vessel and the containment bolts tightened to a torque of 10 ± 0.5 Nm.

7.1.3 Preparation for Transport

- 1) Perform a pre-shipment leak test on the double O-ring closure of the loaded containment vessel at room temperature and atmospheric ambient conditions. The closure shall be leak tested in accordance with the criteria specified in ANSI N14.5 [7.4], using a gas pressure rise or gas pressure drop method with a sensitivity of 10^{-3} ref.cm³/s.
- 2) If the leak rate is unacceptable, recheck the test equipment to ensure there are no leaks. If there are no leaks disconnect from the containment vessel and open the containment vessel. Inspect the O-rings and replace as necessary following steps from 7.1.1. Repeat step one of this section. If the leak test continues to fail, remove the package from service and raise an NCR.
- 3) The inner cork packing and containment vessel shall be fitted into Keg 3979 in the following order: inner cork, containment vessel, ensuring that the containment vessel sits down on the keg liner. Finally insert the top cork ensuring that it is no higher than the surface of the keg closure flange.
- 4) The keg lid seal and the keg lid shall be fitted, the keg closure washers emplaced, and the keg closure nuts tightened to a torque of 23 ± 1 Nm.
- 5) A security seal shall be fitted through the security seal holes in any adjacent pair of lid closure studs.

- 6) A contamination survey shall be conducted on the external surfaces of the package to ensure that the level of non-fixed radioactive contamination is as low as reasonably achievable and within the limits specified in 10 CFR 71.87 and 49 CFR 173.443.
- 7) A radiation survey shall be conducted to verify compliance with 10 CFR 71.47 and 49 CFR 173.441 requirements.
- 8) Optional step: PVC tape may be applied to the body and/or lid of the keg to cover the surface and to facilitate the removal of transport labels.
- 9) The packaging shall be marked and labeled in accordance with 49 CFR requirements. Any inappropriate markings or labels shall be removed. If the keg has been taped ensure all labels are placed on the tape and not on the keg skin. This allows for easy removal of shipping labels.
- 10) A survey of the outside temperature of the package to meet the requirements of 49 CFR 173.442 is not required as conformance with this requirement is assured by the design and proving tests reported in Sections 2 and 3.
- 11) Release the package to the carrier for shipment to the consignee.

7.2 Package Unloading

This section describes the requirements for unloading the package and the contents. It also details the tests and inspections that must be carried out during unloading and opening. Each packaging user shall prepare specific instructions and checklists, in accordance with the organizations Quality Assurance Program, to ensure compliance with the requirements detailed in Sections 7.2.1 and 7.2.2.

7.2.1 Receipt of Package from Carrier

- 1) Confirm that the package is the one identified on the accompanying documentation. Any special requirements of the receiving organization shall be fulfilled.
- 2) The exterior of the package shall be checked for damage that may have occurred during shipment. Damaged packages shall be handled in accordance with the user's facility procedures for handling packages that may not be in a safe condition.
- 3) The radiation and contamination levels on the outer surface of the keg shall be monitored. If, at any stage of unloading, levels of radiation or contamination are detected above those permitted, then the appropriate action shall be taken to safeguard personnel, and to rectify the situation. Radiation level limits are specified in 10 CFR 71.47 and 49 CFR 173.441. The maximum level of removable radioactive contamination on the package surface is specified in 10 CFR 71.87(i) and 49 CFR 173.443.
- 4) The security seals shall be checked to ensure they are intact. If NOT intact investigate the cause and follow internal procedures. No further disassembly of the package shall be attempted until the situation has been resolved.

7.2.2 Removal of Contents

- 1) The security seals, keg closure nuts, washers, and keg lid shall be removed. The opened top of the keg shall be monitored
- 2) The top cork shall be removed.
- 3) The containment vessel shall be lifted from the keg using a 12 mm diameter eyebolt threaded into the lid. The containment vessel shall be monitored for contamination as it is removed from the cork body.
- 4) The containment vessel closure screws and the lid shall be removed.
- 5) If the containment vessel lid is not readily released, as may occur if the containment vessel was loaded at a lower atmospheric pressure, gently jack the lid from the containment vessel body using 2 jacking screws fitted in the jacking holes on the containment vessel lid. The

jacking screws should be left in the containment vessel lid withdrawn to be flush with the lid top surface.

- 6) The containment vessel shall be monitored while the lid is removed.
- 7) The insert shall be removed from the containment vessel.
- 8) The contents shall be removed from the insert in accordance with user's facility procedures, and shall take into account any special requirements for the materials being handled.
- 9) Radiation and contamination surveys of the containment vessel and insert shall be carried out to internal procedures. Decontamination shall be carried out if required.

7.3 Preparation of Empty Packages for Transport

Empty packagings shall meet the requirements of 49 CFR 173.428.

Each packaging user's facility shall prepare specific instructions or procedures and checklists, in accordance with that organization's approved Quality Assurance Program, and ensure compliance with the following requirements when shipping an empty package.

During handling of the package it is recommended that the containment vessel is lifted with a 12mm eyebolt threaded into the lid.

- 1) A contamination survey of the internal surfaces of the containment vessel i.e. the flange/cavity wall and underside of the closure lid shall be performed and the insert. If the non fixed surface contamination exceeds the requirements of 10 CFR 71.87 and 49 CFR 173.443 then decontaminate the containment vessel.
- 2) The insert shall be placed into the cavity of the containment vessel. The lid of the containment vessel shall be placed onto the containment vessel flange and the closure screws shall be tightened. Torque measurements are not required, but ensure all the nuts are tight.
- 3) The inner cork packing and containment vessel shall be fitted into Keg 3979 in the following order: inner cork, containment vessel, ensuring that the containment vessel sits down on the keg liner. Finally insert the top cork ensuring that it is no higher than the surface of the keg
- 4) The keg lid seal and the keg lid shall be fitted, the keg closure washers emplaced, and the keg closure nuts tightened to a torque of 23 ± 1 Nm.
- 5) A contamination survey of the external surfaces of the package shall be performed. Determine if the surface contamination levels meet the requirements of 10 CFR 71.87 and 49 CFR 173.443. If not clean the outside of the package and repeat the contamination survey.
- 6) The empty label as specified in 49 CFR 172.450 shall be attached to the package. Ensure that any labels that have previously been applied are removed, covered or obliterated as required by 49 CFR 173.428.
- 7) The assembled keg should be delivered to a carrier in such condition that subsequent transport will not reduce the effectiveness of the packaging. An empty package should be handled, stored, and shipped according to proper procedures to prevent damage that could affect the subsequent use of the packaging closure flange.

The package may be shipped empty in a damaged condition providing all the components are packed within the keg and keg lid can be fastened securely.

Empty packages should be stored in an area where they are protected from the weather and physical damage. It is recommended that the package be stored in a controlled area to prevent unauthorized tampering or use and that a security seal be in place to provide evidence of tampering.

7.4 Other Operations

There are no other required operations for the package.

7.5 Appendix

7.5.1 References

- [7.1] Title 10, Code of Federal Regulations, Part 71, Office of the Federal Register, Washington D.C.
- [7.2] Title 49, Code of Federal Regulations, Parts 106 – 180, Office of the Federal Register, Washington D.C.
- [7.3] Title 10, Code of Federal Regulations, Part 835, Office of the Federal Register, Washington D.C.
- [7.4] ANSI N14.5, American Standards for Radioactive Materials – Leakage Tests on Packages for Shipment, American National Standards Institute, 2022 edition.

8 Acceptance Test & Maintenance Program

Contents

8	Acceptance Test & Maintenance Program.....	8-1
8.1	Acceptance Tests [71.85]	8-2
8.1.1	Visual Inspections and Measurements.....	8-2
8.1.2	Weld Examinations	8-2
8.1.3	Structural and Pressure Tests [71.85 (b)]	8-2
8.1.4	Leakage Tests	8-3
8.1.5	Component and Material Tests.....	8-3
8.1.5.1	Package weight.....	8-3
8.1.5.2	Containment Vessel O-rings	8-3
8.1.5.3	Containment Vessel Lid Top	8-4
8.1.5.4	Containment Vessel Flange/Cavity Wall.....	8-4
8.1.5.5	Cork	8-4
8.1.5.6	Lead Shielding	8-4
8.1.5.7	Stock Material Used to Manufacture the Containment Boundary.....	8-4
8.1.6	Shielding Tests	8-5
8.1.7	Thermal Tests.....	8-5
8.1.8	Miscellaneous Tests	8-5
8.2	Maintenance Program	8-5
8.2.1	Structural and Pressure Tests	8-6
8.2.2	Leakage Tests.....	8-6
8.2.2.1	Containment Vessel.....	8-6
8.2.2.2	Inserts	8-6
8.2.3	Component and Material Tests.....	8-6
8.2.3.1	Stainless Steel Surfaces	8-6
8.2.3.2	Keg	8-7
8.2.3.3	Containment Vessel.....	8-7
8.2.3.4	Cork Set.....	8-8
8.2.3.5	Inserts	8-8
8.2.4	Thermal Tests.....	8-8
8.2.5	Miscellaneous Tests	8-9
8.2.5.1	Replacement of a Closure Lid	8-9
8.2.5.2	Replacement of the Containment Vessel Body	8-9
8.2.5.3	Replacement of a Containment Vessel	8-9
8.2.5.4	Replacement of a Keg Lid	8-9
8.3	Appendix	8-10
8.3.1	References	8-10

Introduction

This section details the requirements of the acceptance and maintenance test program for the Safkeg-LS 3979A package. The requirements of the sections below ensure compliance with Subpart G of 10 CFR Part 71[8.1].

It is the responsibility of the authorized maintenance organization to produce approved procedures which comply with the requirements of this SARP and 10 CFR 71 Subpart G with regard to all aspects of maintenance. The maintenance organization shall also have a Quality Assurance Program that meets the requirements of 10 CFR 71 Subpart H and shall maintain records that meet the requirements of 10 CFR 71.91.

The authorized maintenance organization is required to notify the SARP owner of any instance in which the packaging fails to meet the criteria of Section 8.2 during maintenance activities.

All drawings referred to in this section are included in Section 1.3.3 of the SARP.

8.1 Acceptance Tests [71.85]

This section describes the requirements for the acceptance tests to be performed prior to the initial use of the packaging. The tests shall be performed in accordance with written procedures produced by the manufacturing organization.

Initial inspection and acceptance tests are carried out during the fabrication of the packaging components by the manufacturer. These tests include dimensional, visual, liquid penetrant and radiographic inspections, structural pressure tests, and leakage tests.

8.1.1 Visual Inspections and Measurements

All components including the inserts shall be subject to visual checks to ensure that they have been fabricated and assembled in accordance with the general arrangement drawings in Section 1.3.3. The dimensions, tolerances and surface finishes shown on the drawings shall be verified by measurement of each packaging component.

Non-conforming components shall be rejected using the approved manufacturer's organization's non-conformance system. Disposition of rejected components should be reworked, used as is, or scrapped and replaced. The SARP owner should be notified of all disposition actions.

8.1.2 Weld Examinations

All keg welds shall be examined according to drawing 0C-6042. The containment vessel welds shall be examined in accordance with drawings 1C-6045 and 1C-6046. Non-conforming components shall be rejected using the approved manufacturer's organization's non-conformance system. Disposition of rejected components should be reworked, used as is, or scrapped and replaced. The SARP owner should be notified of all disposition actions.

8.1.3 Structural and Pressure Tests [71.85 (b)]

A Pressure test of the containment vessel shall be performed in accordance with the ASME B&PV Code, Subsection NB-6000 [4.1]. These tests shall be conducted at 12.5 bar gauge (181 psig) which is 1.25 times the maximum design pressure of 10 bar gauge (145 psig). The pressure shall be held for a minimum of 10 minutes. The pass criteria for the test shall be no gross leakage (i.e. no visible leakage detected without use of instruments) and no permanent deformation of the lid of the containment vessel under test. This test pressure exceeds the requirements of 10 CFR 71.85(b) [8.1] which requires a test pressure of 1.5 x MNOP (7 barg) which is 10.5 bar gauge (152 psig).

Non-conforming components shall be rejected and controlled for rework, or scrapped and replaced. Components that are reworked or replaced shall meet the specifications in the manufacturing drawings and specifications referenced in the certificate and Section 1 of the SARP.

8.1.4 Leakage Tests

Leakage testing of the containment boundary defined in Section 4 shall be carried out in accordance with ANSI N14.5 [8.3]. The containment vessel flange/cavity wall shall be leak tested after fabrication using the gas filled envelope test A.5.3 in ANSI N14.5 [8.3] as described in section 8.1.5.4. The containment vessel lid top shall be helium leak tested prior to and after machining using the gas filled envelope test A.5.3 in ANSI N14.5 [8.3] as described in section 8.1.5.3. Leak rate testing of the containment vessel closure shall be performed using the evacuated envelope gas detector method A.5.4 with helium as the tracer gas and a helium leak detector. The test sensitivity shall be 5×10^{-8} ref.cm³/s and the acceptance rate shall be 1×10^{-7} ref.cm³/s

Leakage testing of the insert shall be carried out in accordance with ANSI N14.5 [8.3]. Leak rate testing shall be performed using the vacuum bubble method. The test sensitivity shall be 10^{-3} ref.cm³/s and the acceptance rate shall be no visible stream of bubbles.

Non-conforming components shall be rejected and controlled for rework, or scrapped and replaced. Components that are reworked or replaced shall meet the specifications in the manufacturing drawings and specifications referenced in the certificate and Section 1 of the SARP.

8.1.5 Component and Material Tests

8.1.5.1 Package weight

The package shall be weighed on a set of calibrated scales with a resolution of 10g. The weight of the package shall not exceed 59 kg (130 lbs). Any non-conforming packages shall be reworked or rejected.

8.1.5.2 Containment Vessel O-rings

In addition to ensuring that the EP O-ring seals meet the specification in drawing 1C-6044 (or 1C-9012), two inner and two outer O-ring seals from each manufacturing batch shall be removed and tested for the ability to remain leaktight, after 1000 hours at 130°C and 24 hours at 200°C in a test rig representing the CV.

One O-ring set (inner and outer) will be used for the 130°C test and another O-ring set shall be used for the 200°C test. The same O-ring set may be used for both tests but each test shall be carried out independently of the other, with each test having a separate helium leak test.

The 3980 prototype containment vessel, serial no 0002 (modified for NCT and HAC testing), may be used as the test rig or, alternatively, a dedicated test rig may be used which replicates the critical dimensions of the containment vessel, including the O-ring seal groove dimensions. The test rig shall be constructed of the same materials as the containment vessel in the vicinity of the O-ring seals.

The test equipment shall include a helium mass spectrometer leakage detector (MSLD) and fittings to connect to the test ports in the test rig lid.

The O-ring shall be lubricated and fitted in position, the closure screws shall be tightened to 10 ± 0.5 Nm. A Thermocouple shall be fitted to the test rig in the O-ring seal interspace. Additional thermocouples may be attached to the surface of the test rig.

The O-rings shall then be tested at 130°C or 200°C depending on the required test. The test rig for both tests shall be placed into an air circulating oven. The temperature of the oven will be raised until the O-rings reach the required temperature of the test either 130°C or 200°C. The temperature of the O-rings shall be maintained for 1000 hours at 130°C to 135°C for the 130°C test or for 24 hours at 200°C to 205°C for the 200°C test. Once the O-rings have been held at the required temperature for the required amount of time the test rig shall be cooled to room temperature.

Once cooled the O-rings shall be helium leak tested using the evacuated envelope gas detector method A.5.4, with helium as the tracer gas and a helium leak detector. The test sensitivity shall be 5×10^{-8} ref.cm³/s and the acceptance rate shall be 1×10^{-7} ref.cm³/s.

8.1.5.3 Containment Vessel Lid Top

The containment vessel lid top shall be helium leak tested prior to machining in accordance with the gas filled envelope test A.5.3 in ANSI N14.5 [8.3], to ensure it is leak tight prior to further manufacture.

The leak test sensitivity shall be a minimum of 5×10^{-8} ref.cm³/s air and the acceptance leak rate shall be 1×10^{-7} ref-cm³/s. Any non-conforming components not meeting this criterion shall be reworked or rejected.

On completion of the machining operation the containment vessel lid top shall be helium leak tested in accordance with the gas filled envelope test A.5.3 in ANSI N14.5 [8.3], to ensure it is leak tight prior to further manufacture.

The leak test sensitivity shall be a minimum of 5×10^{-8} ref.cm³/s air and the acceptance leak rate shall be 1×10^{-7} ref-cm³/s. Any non-conforming components not meeting this criterion shall be reworked or rejected.

8.1.5.4 Containment Vessel Flange/Cavity Wall

The containment vessel flange/cavity wall shall be helium leak tested in accordance with the gas filled envelope test A.5.3 in ANSI N14.5 [8.3], to ensure it is leak tight prior to further manufacture.

The leak test sensitivity shall be a minimum of 5×10^{-8} ref.cm³/s air and the acceptance leak rate shall be 1×10^{-7} ref-cm³/s. Any non-conforming components not meeting this criterion shall be reworked or rejected.

8.1.5.5 Cork

Each batch of the inner, outer and top cork shall have its specific weight measured according to drawing 0C-6043 (section 1.3.3) and meet the criterion of 250 to 290 kg/m³. Any cork not meeting this criterion shall be rejected.

8.1.5.6 Lead Shielding

A chemical analysis shall be carried out for each batch of lead alloy. The chemical composition shall meet the requirements given in drawing 1C-6046 (section 1.3.3).

8.1.5.7 Stock Material Used to Manufacture the Containment Boundary

The stock material, Stainless Steel 304L, used to manufacture items that make up the containment boundary as defined in Section 4.1, shall be examined with liquid penetrant and ultrasonic tests according to drawings 1C-6045 and 1C-6046.

8.1.6 Shielding Tests

Shielding is provided by the inserts and lead in the containment vessel body. Dimensional checks shall be carried out on the inserts in accordance with Section 8.1.1. This is considered an adequate shielding check due to the simple design of the inserts.

The lead shielding shall be checked for defects after casting by Non-Destructive (NDA) examination of the CV body and CV lid using gamma scintillation testing or ultrasonic examination techniques.

Shielding integrity testing identifies weakness in the lead (e.g. porosity, inclusions, blowholes, gaps between successive pours, airlocks and shrinkage cavities) and the complete fill of the cavity. The acceptance criteria shall be < 20% increase in the radiation count rate.

8.1.7 Thermal Tests

A prototype package has been fully tested as described in Section 2 and shown to perform satisfactorily under both Normal Conditions of Transport (NCT) and Hypothetical Accident Conditions (HAC).

The package design is such that specific tests of manufactured components are not required to prove adequate thermal performance. This package has no special thermal features other than the cork insulation. With the low heat load and the design margins on allowable material temperature, the package requires no special thermal testing as part of the post-manufacture acceptance test.

8.1.8 Miscellaneous Tests

Not applicable.

8.2 Maintenance Program

The maintenance program for the SAFKEG 3979A packaging applies to periodic maintenance, and to packagings that have failed the pre-shipment inspection specified in Section 7.1.1. It ensures the continued performance of the package throughout its lifetime.

The maintenance program includes periodic testing, inspection and replacement schedules. Criteria are also included for the repair of components and parts on an 'as needed' basis. A summary of the maintenance requirements is given in Table 8-1.

This section provides the minimum requirements required in order to maintain the package. From these requirements each organization, authorized to perform maintenance, shall prepare specific instructions and checklists, in accordance with that organization's Quality Assurance Program, that will ensure compliance with the requirements of Section 8.2.

Any non-conforming components shall be rejected and controlled for rework, or scrapped and replaced. Components that are reworked or replaced shall meet the specifications in the manufacturing drawings and specifications referenced in the certificate and Section 1 of the SARP.

The maintenance organization is required to notify the SARP owner of any instance in which the packaging fails to meet the criteria of Section 8.2 is found during maintenance.

The periodic maintenance activities, as specified in Section 8.2, shall have been performed not more than 1 year prior to shipment.

8.2.1 Structural and Pressure Tests

Structural and pressure testing do not form part of the periodic maintenance requirements.

8.2.2 Leakage Tests

8.2.2.1 Containment Vessel

Maintenance leakage testing of the containment vessel shall be in accordance with the evacuated envelope (gas detector) test A.5.4 in ANSI N14.5 [8.3]. The test shall use a suitable helium leak detector. The test sensitivity shall be 5×10^{-8} ref.cm³/s and the test pass rate shall be 1×10^{-7} ref.cm³/s. The O-rings shall be coated with a light film of silicone O-ring lubricant for lubrication, and replaced if damaged.

The leakage rate testing shall be performed during the periodic maintenance tests, this shall not exceed 12 months prior to package use. The leakage rate test shall also be performed after the following maintenance activities:

- replacement of the containment seal
- repair of the containment sealing surface
- repair or replacement of the containment vessel lid or body.

8.2.2.2 Inserts

The maintenance leakage testing of the inserts shall be in accordance with the vacuum bubble test A.5.6(b) in ANSI N14.5 [8.3]. The test sensitivity shall be 10^{-3} ref.cm³/s and the acceptance rate shall be no visible stream of bubbles.

The leakage rate testing shall be performed during the periodic maintenance tests, this shall not exceed 12 months prior to package use. The leakage rate test shall also be performed after the following maintenance activities:

- replacement of the insert seal
- repair of the insert sealing surface
- repair or replacement of the insert lid or body.

8.2.3 Component and Material Tests

The following sections describe the periodic maintenance requirements for package operation. Additional maintenance may be required on packagings that have failed the pre-shipment inspection process. Any additional maintenance requirements shall follow the periodic maintenance and its associated record keeping requirements.

8.2.3.1 Stainless Steel Surfaces

All of the stainless steel surfaces of the keg and containment vessels shall be visually inspected for corrosion. The presence of any surface corrosion on any component shall be cause for further inspection. If the corrosion can be easily wiped off, and no pitting is apparent beneath it, the component is acceptable. If the corrosion cannot be easily wiped off, or if scaling is present, or if pitting is observed, then the surface shall be reworked and the component must undergo a dimensional inspection and dye penetrant and/or radiographic testing to determine the extent of the damage.

In the case of the containment vessel, a hydrostatic test shall be performed. All acceptance criteria for a newly fabricated component (drawing 1C-6044 or 1C-9012) shall apply to the reworked component. If the corrosion has compromised the structural integrity of the component (e.g. the component no longer meets dimensional criteria for a new part as specified on drawing

1C-6044 or 1C-9012), then the component shall be rejected. The inspection results and any necessary replacement or repairs, shall be recorded in the package maintenance records.

8.2.3.2 Keg

1. The model/serial numbers of the keg assembly (keg body and keg lid) shall be checked to be matched: where the model/serial numbers of the keg assembly (body and lid) do not match, these assemblies shall be removed from service.
2. The keg name plate shall be checked for legibility of the nameplate information.
3. The keg outer shell shall be visually checked for unacceptable defects. Unacceptable defects are dents greater than 8.9 mm (1 in.) in depth; cracking of welded joints; penetration of the keg skin; or abrasion or scratches greater than half the thickness of the keg skin [shell thickness is 2 mm (0.080 in.)].
4. The keg closure studs shall be checked for tightness of fit in the keg top flange and damage (i.e. stripped or distorted). A die nut (thread class 6g) shall be used to clear any tight threads. The closure studs shall be checked that they are positioned in accordance with drawing 0C-6042. If the stud is loose or the height is incorrect, the stud shall be removed, cleaned, and repositioned using Loctite 270 or Loctite 263. If any keg closure studs are damaged they shall be replaced according to drawing 0C-6042.
5. The keg lid seal and respective groove shall be checked for visible damage such as splits or cuts in the lid seal and scratches in the lid seal groove. The lid seal shall fit correctly into the seal groove. The lid seal shall be replaced as necessary; there is no requirement for periodic replacement.
6. The keg, keg lid, and keg closure nuts shall fit up freely. Any damaged nuts or washers shall be replaced according to drawing 0C-6042.
7. The fuse plug and spring washer shall be visually inspected for presence in the keg and damage and wear. A damaged or missing fuse plug or washer shall be replaced according to the specifications in drawing 0C-6042.
8. Nonconforming components shall be rejected and controlled for rework, or scrapped and replaced. Components that are reworked or replaced shall meet the specifications in the manufacturing drawings and specifications referenced in the certificate and Section 1 of the SARP.
9. The inspection results and any necessary replacement or repairs, shall be recorded in the package maintenance records.

8.2.3.3 Containment Vessel

1. The model/serial numbers of the body and lid shall be checked to be matched: where the model/serial numbers of the containment vessel assembly (body and lid) do not match, these assemblies shall be removed from service.
2. The Containment Vessel components shall be checked for visible damage and in particular that the closure components assemble freely by hand. Any defects affecting the operation or integrity must be corrected or a part replaced.
3. The welds on the containment vessel body and lid shall be visually checked for defects and evidence of cracking.
4. The threads in the closure of the containment vessel and the closure screws shall be cleaned and the threads shall be coated with molybdenum disulfide dry film spray lubricant.
5. The surface finish of the faces against which the O-rings seat shall be visually inspected. These faces shall be circular and there shall be no scratches across the lay. Scratches shall be polished out to return the surface to the specification in the drawings or the component rejected.
6. The three O-rings marked on drawing 1C-6044 (or 1C-9012) shall be replaced. These O-rings must be replaced annually. The O-rings shall be coated with a light film of silicone O-

ring lubricant (Parker Super O-Lube). The O-rings shall be within the valid expiration date as specified by the manufacturer. O-rings shall be procured and tested in accordance with drawing 1C-6044 (or 1C-9012).

7. Leakage testing of the containment vessel shall be carried out in accordance with ANSI N14.5 [8.3]. The test sensitivity shall be 5×10^{-8} ref.cm³/s and the test pass rate shall be 1×10^{-7} ref.cm³/s.
8. Nonconforming components shall be rejected and controlled for rework, or scrapped and replaced. Components that are reworked or replaced shall meet the specifications in the manufacturing drawings and specifications referenced in the certificate and Section 1 of the SARP.
9. The inspection results and any necessary replacement or repairs, shall be recorded in the package maintenance records.

8.2.3.4 Cork Set

1. The cork packing pieces (top cork, inner cork and outer cork) shall be visually inspected for chipping and cracking. The pieces shall be checked for fit within the assembled package. They shall fit without interference.
2. Non-conforming components shall be rejected and controlled for rework, or scrapped and replaced. Components that are reworked or replaced shall meet the specifications drawing 0C-6043 and specifications referenced in the certificate and Section 1 of the SARP.
3. The inspection results and any necessary replacement or repairs, shall be recorded in the package maintenance records.

8.2.3.5 Inserts

1. The model/serial numbers of the body and lid shall be checked to be matched: where the model/serial numbers of the insert (body and lid) do not match, these assemblies shall be removed from service.
2. The insert components shall be checked for visible damage and in particular that the lid screws freely by hand onto the body. Any defects affecting the operation or integrity must be corrected or a part replaced.
3. The lid and body threads shall be cleaned and coated with molybdenum disulfide dry film spray lubricant.
4. The presence of the O-ring shall be checked and replaced if missing. The O-ring shall be coated with a light film of silicone O-ring lubricant.
5. The insert shall be leak tested as specified in section 8.2.2.2.
6. Non-conforming components shall be rejected and controlled for rework, or scrapped and replaced. Components that are reworked or replaced shall meet the specifications on drawing 2C-6171, 2C-6172 and 2C-6175 and the specifications referenced in the certificate and Section 1 of the SARP.
7. The inspection results and any necessary replacement or repairs, shall be recorded in the package maintenance records.

8.2.4 Thermal Tests

This package has no special thermal features other than the cork insulation. Therefore, the package requires no special thermal testing as part of the routine maintenance. Visual inspection is sufficient to check that components are in satisfactory condition.

8.2.5 Miscellaneous Tests

This section discusses the requirements for replacing component parts on the package. These parts may be newly manufactured or substituted components from other packages. The keg which bears the serial number of the package will form the host component.

8.2.5.1 Replacement of a Closure Lid

If a closure lid is replaced, a maintenance leak rate test shall be performed in accordance with Section 8.1.4. The replacement shall be noted in the maintenance log along with the results of the leak test.

8.2.5.2 Replacement of the Containment Vessel Body

If the containment vessel body is replaced, it shall first be checked to ensure that the lid, closure screws and O-rings all fit. A maintenance leak test shall then be performed according to Section 8.1.4. The replacement shall be noted in the maintenance log along with the results of the leak test.

8.2.5.3 Replacement of a Containment Vessel

If the containment vessel is substituted the replacement shall be noted in the package maintenance log. The replacement containment vessel shall be manufactured to the requirements shown in the general arrangement drawings in Section 1.3.3.

8.2.5.4 Replacement of a Keg Lid

If the keg lid is replaced, the replacement shall be noted in the package maintenance log.

Table 8-1 Package Maintenance Summary

Item	SARP Section	Pre Shipment Action	Annual Maintenance Action	Tests on repair/replacement
Containment Vessel Surfaces	8.2.3.3	V	V	Leak Test
Containment O-ring	8.2.3.3	V, Leak Test	R, Leak Test	Leak Test
Leak test O-ring	8.2.3.3	V	R	
Test Port O-ring	8.2.3.3	V	R	
O-ring sealing surfaces	8.2.3.3	V	V	
Containment Vessel threaded inserts	8.2.3.3	O	V	
Containment vessel screws	8.2.3.3	O, V	V	
Keg surfaces	8.2.3.2	V	V	
Keg lid seal	8.2.3.2	V	V	
Lid seal sealing surfaces	8.2.3.2	V	V	
Keg Studs	8.2.3.2	O, V	V	
Keg bolts and washers	8.2.3.2	O	V	
Fuse plug	8.2.3.2		V	
Fuse plug washer	8.2.3.2		V	

Item	SARP Section	Pre Shipment Action	Annual Maintenance Action	Tests on repair/replacement
Cork	8.2.3.4	V	V	

Notes: V = Visual Inspection, R = Replace, O = Operational test

8.3 Appendix

8.3.1 References

- [8.1] Title 10, Code of Federal Regulations, Part 71, Office of the Federal Register, Washington D.C.
- [8.2] ASME III Division 1 – Subsection NB, Class One Components, Rules for Construction of Nuclear Facility Components, ASME Boiler and Pressure Vessel Code, 2001 edition, the American Society of Mechanical Engineers, New York, New York.
- [8.3] ANSI N14.5, American Standards for Radioactive Materials – Leakage Tests on Packages for Shipment, American National Standards Institute, 2022 edition.