

May 4, 2026

Docket Nos.: 50-424  
50-425

NL-26-0155

U. S. Nuclear Regulatory Commission  
ATTN: Document Control Desk  
Washington, D. C. 20555-0001

Vogtle Electric Generating Plant – Units 1 and 2  
Annual Radioactive Effluent Release Report and  
Annual Non-Radiological Environmental Operating Report for 2025

Ladies and Gentlemen:

In accordance with section 5.6.3 of the Vogtle Electric Generating Plant (VEGP) - Units 1 and 2 Technical Specifications (TS), Southern Nuclear Operating Company submits the enclosed Annual Radioactive Effluent Release Report for 2025.

Per section 5.5.1.c of the VEGP Units 1 and 2 TS, any Offsite Dose Calculation Manual (ODCM) revisions must accompany the Radioactive Effluent Release Report. During the 2025 reporting period, ODCM revisions for VEGP Units 1 and 2 occurred and are included as enclosures.

Additionally, in accordance with subsection 5.4.1 of the VEGP Units 1 and 2 Environmental Protection Plan (Appendix B to the operating licenses), Southern Nuclear Operating Company submits the Annual Non-Radiological Environmental Operating Report for 2025, also enclosed with this letter.

This letter contains no NRC commitments. If you have any questions, please contact Ryan Joyce at 205.992.6468.

Respectfully submitted,

Jamie M. Coleman  
Director, Regulatory Affairs  
Southern Nuclear Operating Company

JMC/btr/cbg

Enclosure: 1. VEGP Units 1 and 2 Annual Radioactive Effluent Release Report (2025)  
2. VEGP Units 1 and 2 Offsite Dose Calculation Manual - Version 38  
3. VEGP Units 1 and 2 Annual Non-Radiological Environmental Operating (2025)

cc: Regional Administrator, Region II  
NRR Project Manager – Vogtle 1&2  
Senior Resident Inspector – Vogtle 1&2  
R-Type: CVC7000

**Vogtle Electric Generating Plant – Units 1 and 2**  
**Annual Radioactive Effluent Release Report and**  
**Annual Non-Radiological Environmental Operating Report for 2025**

**Enclosure 1 to NL-26-0155**

**VEGP Units 1 and 2 Annual Radioactive Effluent Release Report (2025)**



2025

# Annual Radioactive Effluent Release Report

Document Number: 50-424 & 50-425  
Facility Operating License Nos. NPF-68 & NPF-81

Prepared By: Michael Baker /  Date: 4/13/2026  
Nuclear Chemist

Reviewed By: Alan Steinmen /  Date: 4/13/2026  
Chemistry Manager

|  |  |              |
|--|--|--------------|
| Annual Radioactive Effluent Release Report | YEAR: 2025   | Page 1 of 81 |
| <b>Company: Southern Nuclear Company</b>   | <b>Plant: Vogtle Electric Generating Plant 1&amp;2</b> |              |

Page Intentionally Left Blank

**TABLE OF CONTENTS**

- 1.0 LIST OF ACRONYMS AND DEFINITIONS ..... 4
- 2.0 EXECUTIVE SUMMARY ..... 6
  - 2.1 Comparison to Regulatory Limits ..... 7
- 3.0 INTRODUCTION..... 12
  - 3.1 About Nuclear Power ..... 12
  - 3.2 About Radiation Dose ..... 14
  - 3.3 About Dose Calculation ..... 16
- 4.0 DOSE ASSESSMENT FOR PLANT OPERATIONS ..... 18
  - 4.1 Regulatory Limits ..... 18
  - 4.2 Regulatory Limits for Gaseous Effluent Doses: ..... 18
  - 4.3 Regulatory Limits for Liquid Effluent Doses..... 19
  - 4.4 40 CFR 190 Regulatory Dose Limits for a Member of the Public ..... 20
  - 4.5 Onsite Doses (Within Site Boundary) ..... 20
- 5.0 SUPPLEMENTAL INFORMATION ..... 21
  - 5.1 Gaseous Batch Releases ..... 21
  - 5.2 Liquid Batch Releases ..... 22
  - 5.3 Abnormal Releases ..... 22
  - 5.4 Land Use Census Changes ..... 23
  - 5.5 Meteorological Data ..... 24
  - 5.6 Effluent Radiation Monitors Out of Service Greater Than 30 Days ..... 24
  - 5.7 Offsite Dose Calculation Manual (ODCM) Changes ..... 25
  - 5.8 Process Control Program (PCP) Changes ..... 35
  - 5.9 Radioactive Waste Treatment System Changes ..... 35
  - 5.10 Other Supplemental Information ..... 35
- 6.0 NEI 07-07 ONSITE RADIOLOGICAL GROUNDWATER MONITORING PROGRAM ..... 46
  - 6.1 Voluntary Notification ..... 46
- 7.0 BIBLIOGRAPHY ..... 47

**TABLES**

- Table 1, Vogtle Electric Generating Plant 1&2 (Unit 1) Dose Summary ..... 7
- Table 2, Vogtle Electric Generating Plant 1&2 (Unit 2) Dose Summary ..... 8
- Table 3, Vogtle Electric Generating Plant 1&2 (Site) Dose Summary ..... 9
- Table 4, Total Annual Offsite-Dose Comparison to 40 CFR 190 Limits for VEGP ..... 11
- Table 5, Onsite Doses (Within Site Boundary) ..... 21
- Table 6, Gaseous Effluents Summation of All Releases (Unit 1)..... 48
- Table 7, Gaseous Effluents – Mixed Level Release Continuous Mode (Unit 1) ..... 49
- Table 8, Gaseous Effluents – Mixed Level Release Batch Mode (Unit 1)..... 50
- Table 9, Gaseous Effluents – Ground Level Release Continuous Mode (Unit 1)..... 51
- Table 10, Gaseous Effluents – Ground Level Release Batch Mode (Unit 1) ..... 52
- Table 11, Gaseous Effluents Summation of All Releases (Unit 2)..... 53

|  |  |
|--|--|
| <b>Company: Southern Nuclear Company</b> | <b>Plant: Vogtle Electric Generating Plant 1&amp;2</b> |
|--|--|

|   |    |
|---|----|
| Table 12, Gaseous Effluents – Mixed Level Release Continuous Mode (Unit 2).....   | 54 |
| Table 13, Gaseous Effluents – Mixed Level Release Batch Mode (Unit 2).....        | 55 |
| Table 14, Gaseous Effluents – Ground Level Release Continuous Mode (Unit 2).....  | 56 |
| Table 15, Gaseous Effluents – Ground Level Release Batch Mode (Unit 2) .....      | 57 |
| Table 16, Gaseous Effluents Summation of All Releases (Site) .....                | 58 |
| Table 17, Gaseous Effluents – Mixed Level Release Continuous Mode (Site) .....    | 59 |
| Table 18, Gaseous Effluents – Mixed Level Release Batch Mode (Site).....          | 60 |
| Table 19, Gaseous Effluents – Ground Level Release Continuous Mode (Site).....    | 61 |
| Table 20, Gaseous Effluents – Ground Level Release Batch Mode (Site).....         | 62 |
| Table 21, Minimum Detectable Concentrations Gaseous Sample Analysis.....          | 63 |
| Table 22, Liquid Effluents – Summation of All Releases (Unit 1).....              | 64 |
| Table 23, Continuous Mode Liquid Effluents (Unit 1) .....                         | 65 |
| Table 24, Batch Mode Liquid Effluents (Unit 1) .....                              | 66 |
| Table 25, Liquid Effluents – Summation of All Releases (Unit 2).....              | 67 |
| Table 26, Continuous Mode Liquid Effluents (Unit 2) .....                         | 68 |
| Table 27, Batch Mode Liquid Effluents (Unit 2) .....                              | 69 |
| Table 28, Liquid Effluents – Summation of All Releases (Site).....                | 70 |
| Table 29, Continuous Mode Liquid Effluents (Site) .....                           | 71 |
| Table 30, Batch Mode Liquid Effluents (Site) .....                                | 72 |
| Table 31, Minimum Detectable Concentrations-Liquid Sample Analyses.....           | 73 |
| Table 32, Solid Waste Shipped Offsite January 1, 2024 Through June 30, 2024 ..... | 74 |
| Table 33, Solid Waste Shipped Offsite July 1, 2024 Through December 31, 2024..... | 76 |

**FIGURES**

|  |    |
|--|----|
| Figure 1, Pressurized Water Reactor (PWR) [1].....   | 12 |
| Figure 2, Boiling Water Reactor (BWR) [2].....   | 13 |
| Figure 3, Sources of Radiation Exposure (NCRP Report No. 160) [3].....                           | 14 |
| Figure 4, Potential exposure pathways to Members of the Public due to Plant Operations [6] ..... | 16 |

**ATTACHMENTS**

|  |    |
|--|----|
| Attachment 1, ARERR Release Summary Tables (RG-1.21 Tables) .....                | 48 |
| Attachment 2, Solid Waste Information .....                                      | 74 |
| Attachment 3, NEI 07-07 Onsite Radiological Groundwater Monitoring Program ..... | 78 |

## 1.0 LIST OF ACRONYMS AND DEFINITIONS

1. *a priori*: Before the fact limit representing the capability of a measurement system and not as an after the fact (*a posteriori*) limit for a particular measurement.
2. Airborne Activity Sampling: Sampling of air through the collection of particulates and radionuclides on filter media, collection of noble gases in a container, and collection of water vapor containing tritium.
3. Alpha Particle ( $\alpha$ ): A charged particle emitted from the nucleus of an atom having a mass and charge equal in magnitude of a helium nucleus.
4. BWR: Boiling Water Reactor
5. Composite Sample: A series of single collected portions (aliquots) analyzed as one sample. The aliquots making up the sample are collected at time intervals that are very short compared to the composite period.
6. Control: A sampling station in a location not likely to be affected by plant effluents due to its distance and/or direction from the Plant.
7. Counting Error: An estimate of the two-sigma uncertainty associated with the sample results based on total counts accumulated.
8. Curie (Ci): A measure of radioactivity; equal to  $3.7 \times 10^{10}$  disintegrations per second, or  $2.22 \times 10^{12}$  disintegrations per minute.
9. Direct Radiation Monitoring: The measurement of radiation dose at various distances from the plant is assessed using thermoluminescent dosimeters (TLDs), optically stimulated luminescent dosimeters (OSLDs), and/or pressurized ionization chambers.
10. ECL: Effluent Concentration Limit
11. Grab Sample: A single discrete sample drawn at one point in time.
12. Indicator: A sampling location that is likely to be affected by plant effluents due to its proximity and/or direction from the plant.
13. Ingestion Pathway: The ingestion pathway includes milk, fish, and garden produce. Meat or other food products may also be included.
14. ISFSI: Independent Spent Fuel Storage Installation
15. Lower Limit of Detection (LLD): The smallest concentration of radioactive material in a sample that will yield a net count (above system background) that will be detected with 95% probability with a 5% probability of a false conclusion that a blank observation represents "real" signal.

16. MDA: Minimum Detectable Activity. - For radiochemistry instruments, the MDA is the a posteriori minimum concentration that a counting system detects. The smallest concentration or activity of radioactive material in a sample that will yield a net count above instrument background and that is detected with 95% probability, with only five % probability of falsely concluding that a blank observation represents a true signal.
17. MDC: Minimum Detectable Concentration, essentially synonymous with MDA for the purposes of radiological monitoring.
18. Mean: The average, i.e., the sum of results divided by the number of results.
19. Microcurie ( $\mu\text{Ci}$ ):  $3.7 \times 10^4$  disintegrations per second, or  $2.22 \times 10^6$  disintegrations per minute.
20. millirem (mrem): 1/1000 rem; a unit of radiation dose equivalent in tissue.
21. Milliroentgen (mR): 1/1000 Roentgen; a unit of exposure to X- or gamma radiation.
22. MWe: Megawatts Electric
23. MWTh: Megawatts Thermal
24. NA: Not Applicable
25. NEI: Nuclear Energy Institute
26. NRC: Nuclear Regulatory Commission
27. ODCM: Offsite Dose Calculation Manual
28. OSLD: Optically Stimulated Luminescence Dosimeter
29. Protected Area: The fenced area immediately surrounding the Plant. Access to the protected area requires a security badge or escort.
30. PWR: Pressurized Water Reactor
31. REC: Radiological Effluent Control
32. REMP: Radiological Environmental Monitoring Program
33. Restricted Area: Any area where access is controlled for the purpose of protecting individuals from exposure to radiation or radioactive materials.
34. SLCs: Selected Licensee Commitments
35. TEDE: Total Effective Dose Equivalent (TEDE) means the sum of the effective dose equivalent (for external exposures) and the committed effective dose equivalent (for internal exposures).

|  |  |              |
|--|--|--------------|
| Annual Radioactive Effluent Release Report | YEAR: 2025   | Page 6 of 81 |
| <b>Company: Southern Nuclear Company</b>   | <b>Plant: Vogtle Electric Generating Plant 1&amp;2</b> |              |

- 36. TLD: Thermoluminescent Dosimeter
- 37. TRM: Technical Requirements Manual
- 38. TS: Technical Specification

## 2.0 EXECUTIVE SUMMARY

Vogtle Electric Generating Plant 1&2 (VEGP) Radiological Effluent Control (REC) Program was established to limit the quantities of radioactive material that may be released based on calculated radiation doses or dose rates. Dose to Members of the Public due to radioactive materials released from the plant is limited by Appendix I of 10 CFR 50 and by 40 CFR 190. Operational doses to the public during 2025 were calculated to be very small compared to the limits required by regulation and compared to other sources of radiation dose and pose no health hazard. These doses are summarized and compared to the regulatory limits in Section 2.1, Comparison to Regulatory Limits, below.

The Annual Radioactive Effluent Release Report (ARERR) is published per REC requirements and provides data related to plant operation, including: quantities of radioactive materials released in liquid and gaseous effluents; radiation doses to members of the public; solid radioactive waste shipped offsite for disposal; and other information as required by site licensing documents.

In 2025 the Land Use Census dose assessments due to radioactive gaseous effluents showed that the critical receptor for Vogtle Electric Generating Plant 1&2 is Child, due to exposure pathways of inhalation, ground plane, cow meat and garden, at location 1.2 miles, WSW. The maximum Annual Organ Dose calculated for this receptor was 4.355E-03 (Units 1 and 2), to the Thyroid. This annual dose is a small fraction of the 10 CFR 50, Appendix I guideline of 30 mrem to the Maximum Organ (15 mrem per reactor unit).

Solid radioactive waste shipped offsite for disposal included 4.12E+01 Curies and 4.96E+02 m<sup>3</sup>, shipped in 24 shipments.

In addition to monitoring radioactive effluents, VEGP has a Radiological Environmental Monitoring Program (REMP) that monitors for buildup of radioactivity in the offsite environment. Data from the REMP is published in the Annual Radiological Environmental Operating Report (AREOR).

## 2.1 Comparison to Regulatory Limits

During 2025 all solid, liquid, and gaseous radioactive effluents from Vogtle Electric Generating Plant 1&2 were well below regulatory limits, as summarized in Table 1, Table 2 and Table 4. Table 3 is a summary of the cumulative dose from both units.

Table 1, Vogtle Electric Generating Plant 1&2 (Unit 1) Dose Summary<sup>1</sup>

|  |                 | Quarter 1       | Quarter 2       | Quarter 3       | Quarter 4       | Annual         |
|--|-----------------|-----------------|-----------------|-----------------|-----------------|----------------|
| Liquid Effluent Dose Limit, Total Body   | <b>Limit</b>    | <b>1.5 mrem</b> | <b>1.5 mrem</b> | <b>1.5 mrem</b> | <b>1.5 mrem</b> | <b>3 mrem</b>  |
|  | Total Body Dose | 1.75E-02        | 4.82E-03        | 2.54E-03        | 9.11E-04        | 2.57E-02       |
|  | % of Limit      | 1.16E+00        | 3.22E-01        | 1.69E-01        | 6.07E-02        | 8.57E-01       |
| Liquid Effluent Dose Limit, Any Organ  | <b>Limit</b>    | <b>5 mrem</b>   | <b>5 mrem</b>   | <b>5 mrem</b>   | <b>5 mrem</b>   | <b>10 mrem</b> |
|  | Max Organ Dose  | 1.77E-02        | 5.32E-03        | 2.56E-03        | 1.00E-03        | 2.66E-02       |
|  | % of Limit      | 3.55E-01        | 1.06E-01        | 5.11E-02        | 2.00E-02        | 2.66E-01       |
| Gaseous Effluent Dose Limit, Gamma Air (Noble Gas)                                       | <b>Limit</b>    | <b>5 mrad</b>   | <b>5 mrad</b>   | <b>5 mrad</b>   | <b>5 mrad</b>   | <b>10 mrad</b> |
|  | Gamma Air Dose  | 1.21E-05        | 1.09E-05        | 1.32E-05        | 1.50E-05        | 5.13E-05       |
|  | % of Limit      | 2.42E-04        | 2.18E-04        | 2.65E-04        | 3.01E-04        | 5.13E-04       |
| Gaseous Effluent Dose Limit, Beta Air (Noble Gas)  | <b>Limit</b>    | <b>10 mrad</b>  | <b>10 mrad</b>  | <b>10 mrad</b>  | <b>10 mrad</b>  | <b>20 mrad</b> |
|  | Beta Air Dose   | 4.27E-06        | 4.00E-06        | 4.87E-06        | 5.38E-06        | 1.85E-05       |
|  | % of Limit      | 4.27E-05        | 4.00E-05        | 4.87E-05        | 5.38E-05        | 9.27E-05       |
| Gaseous Effluent Organ Dose Limit (Iodine, Tritium, Particulates with > 8-day half-life) | <b>Limit</b>    | <b>7.5 mrem</b> | <b>7.5 mrem</b> | <b>7.5 mrem</b> | <b>7.5 mrem</b> | <b>15 mrem</b> |
|  | Max Organ Dose  | 3.00E-03        | 9.91E-05        | 6.31E-05        | 1.07E-04        | 3.27E-03       |
|  | % of Limit      | 3.99E-02        | 1.32E-03        | 8.41E-04        | 1.42E-03        | 2.18E-02       |

<sup>1</sup> Table 1 demonstrates compliance with 10 CFR Part 50, App. I Limits.

**Company: Southern Nuclear Company****Plant: Vogtle Electric Generating Plant 1&2**Table 2, Vogtle Electric Generating Plant 1&2 (Unit 2) Dose Summary<sup>1</sup>

|  |                   | Quarter 1       | Quarter 2       | Quarter 3       | Quarter 4       | Annual         |
|--|-------------------|-----------------|-----------------|-----------------|-----------------|----------------|
| Liquid Effluent<br>Dose Limit,<br>Total Body   | <b>Limit</b>      | <b>1.5 mrem</b> | <b>1.5 mrem</b> | <b>1.5 mrem</b> | <b>1.5 mrem</b> | <b>3 mrem</b>  |
|  | Total Body Dose   | 8.12E-03        | 4.37E-03        | 1.77E-03        | 7.70E-04        | 1.50E-02       |
|  | % of Limit        | 5.42E-01        | 2.92E-01        | 1.18E-01        | 5.13E-02        | 5.01E-01       |
| Liquid Effluent<br>Dose Limit,<br>Any Organ  | <b>Limit</b>      | <b>5 mrem</b>   | <b>5 mrem</b>   | <b>5 mrem</b>   | <b>5 mrem</b>   | <b>10 mrem</b> |
|  | Max Organ Dose    | 8.38E-03        | 4.53E-03        | 1.79E-03        | 8.02E-04        | 1.55E-02       |
|  | % of Limit        | 1.68E-01        | 9.07E-02        | 3.58E-02        | 1.60E-02        | 1.55E-01       |
| Gaseous Effluent<br>Dose Limit,<br>Gamma Air<br>(Noble Gas)  | <b>Limit</b>      | <b>5 mrad</b>   | <b>5 mrad</b>   | <b>5 mrad</b>   | <b>5 mrad</b>   | <b>10 mrad</b> |
|  | Gamma Air<br>Dose | 5.54E-06        | 5.52E-06        | 5.23E-06        | 5.87E-06        | 2.22E-05       |
|  | % of Limit        | 1.11E-04        | 1.10E-04        | 1.05E-04        | 1.17E-04        | 2.22E-04       |
| Gaseous Effluent<br>Dose Limit,<br>Beta Air<br>(Noble Gas)   | <b>Limit</b>      | <b>10 mrad</b>  | <b>10 mrad</b>  | <b>10 mrad</b>  | <b>10 mrad</b>  | <b>20 mrad</b> |
|  | Beta Air Dose     | 2.07E-06        | 2.42E-06        | 1.84E-06        | 2.07E-06        | 8.41E-06       |
|  | % of Limit        | 2.07E-05        | 2.42E-05        | 1.84E-05        | 2.07E-05        | 4.20E-05       |
| Gaseous Effluent<br>Organ Dose Limit<br>(Iodine, Tritium,<br>Particulates with<br>> 8-day half-life) | <b>Limit</b>      | <b>7.5 mrem</b> | <b>7.5 mrem</b> | <b>7.5 mrem</b> | <b>7.5 mrem</b> | <b>15 mrem</b> |
|  | Max Organ Dose    | 3.28E-04        | 2.49E-04        | 4.55E-04        | 5.91E-05        | 1.09E-03       |
|  | % of Limit        | 4.37E-03        | 3.31E-03        | 6.06E-03        | 7.87E-04        | 7.27E-03       |

<sup>1</sup> Table 2 demonstrates compliance with 10 CFR Part 50, App. I Limits.

Table 3, Vogtle Electric Generating Plant 1&2 (Site) Dose Summary<sup>1</sup>

|  |                 | Quarter 1      | Quarter 2      | Quarter 3      | Quarter 4      | Annual         |
|--|-----------------|----------------|----------------|----------------|----------------|----------------|
| Liquid Effluent<br>Dose Limit,<br>Total Body   | <b>Limit</b>    | <b>3 mrem</b>  | <b>3 mrem</b>  | <b>3 mrem</b>  | <b>3 mrem</b>  | <b>6 mrem</b>  |
|  | Total Body Dose | 2.56E-02       | 9.20E-03       | 4.31E-03       | 1.68E-03       | 4.08E-02       |
|  | % of Limit      | 8.53E-01       | 3.07E-01       | 1.44E-01       | 5.60E-02       | 6.80E-01       |
| Liquid Effluent<br>Dose Limit,<br>Any Organ  | <b>Limit</b>    | <b>10 mrem</b> | <b>10 mrem</b> | <b>10 mrem</b> | <b>10 mrem</b> | <b>20 mrem</b> |
|  | Max Organ Dose  | 2.61E-02       | 9.86E-03       | 4.35E-03       | 1.80E-03       | 4.21E-02       |
|  | % of Limit      | 2.61E-01       | 9.86E-02       | 4.35E-02       | 1.80E-02       | 2.11E-01       |
| Gaseous Effluent<br>Dose Limit,<br>Gamma Air<br>(Noble Gas)  | <b>Limit</b>    | <b>10 mrad</b> | <b>10 mrad</b> | <b>10 mrad</b> | <b>10 mrad</b> | <b>20 mrad</b> |
|  | Gamma Air Dose  | 1.77E-05       | 1.64E-05       | 1.85E-05       | 2.09E-05       | 7.35E-05       |
|  | % of Limit      | 1.77E-04       | 1.64E-04       | 1.85E-04       | 2.09E-04       | 3.68E-04       |
| Gaseous Effluent<br>Dose Limit,<br>Beta Air<br>(Noble Gas)   | <b>Limit</b>    | <b>20 mrad</b> | <b>20 mrad</b> | <b>20 mrad</b> | <b>20 mrad</b> | <b>40 mrad</b> |
|  | Beta Air Dose   | 6.35E-06       | 6.42E-06       | 6.72E-06       | 7.45E-06       | 2.69E-05       |
|  | % of Limit      | 3.18E-05       | 3.21E-05       | 3.36E-05       | 3.73E-05       | 6.74E-05       |
| Gaseous Effluent<br>Organ Dose Limit<br>(Iodine, Tritium,<br>Particulates with<br>> 8-day half-life) | <b>Limit</b>    | <b>15 mrem</b> | <b>15 mrem</b> | <b>15 mrem</b> | <b>15 mrem</b> | <b>30 mrem</b> |
|  | Max Organ Dose  | 3.32E-03       | 3.48E-04       | 5.18E-04       | 1.66E-04       | 4.35E-03       |
|  | % of Limit      | 2.21E-02       | 2.32E-03       | 3.45E-03       | 1.11E-03       | 1.45E-02       |

<sup>1</sup> Compliance to 10 CFR Part 50, Appendix I Limits is demonstrated from Tables 1 and 2 for each unit. Table 3 is a summary of the cumulative dose from both units.

|  |  |               |
|--|--|---------------|
| Annual Radioactive Effluent Release Report | YEAR: 2025   | Page 10 of 81 |
| <b>Company: Southern Nuclear Company</b>   | <b>Plant: Vogtle Electric Generating Plant 1&amp;2</b> |               |

ODCM 5.1 states in part that the annual (calendar year) dose or dose commitment to any MEMBER OF THE PUBLIC due to releases of radioactivity and to radiation from uranium fuel cycle sources shall be limited to less than or equal to 25 mrem to the whole body or to any organ, except the thyroid, which shall be limited to less than or equal to 75 mrem.

No dose limits stated in ODCM Sections 2.1.3, 3.1.3, and 3.1.4 were exceeded. Therefore, compliance with 40 CFR 190 dose limits was demonstrated in accordance with the requirements of ODCM Section 5.1.3. However, Table 4 was included to demonstrate compliance with 40 CFR 190.

Table 4, Total Annual Offsite-Dose Comparison to 40 CFR 190 Limits for VEGP<sup>1</sup>

|  | <b>Whole Body</b> | <b>Thyroid</b>  | <b>Max Other Organ</b> |
|--|-------------------|-----------------|------------------------|
| <b>Limit</b>                                     | <b>25 mrem</b>    | <b>75 mrem</b>  | <b>25 mrem</b>         |
| <b>Gaseous</b>                                   |                   |                 |                        |
| Unit 1 Noble Gas                                 | 4.87E-05          | 7.14E-05        | 7.14E-05               |
| Unit 1 Particulate and Iodine                    | 3.27E-03          | 3.27E-03        | 3.27E-03               |
| Unit 1 C-14                                      | 1.69E-02          | 1.69E-02        | 8.45E-02               |
| Unit 2 Noble Gas                                 | 2.10E-05          | 3.09E-05        | 3.09E-05               |
| Unit 2 Particulate and Iodine                    | 1.09E-03          | 1.09E-03        | 1.09E-03               |
| Unit 2 C-14                                      | 1.69E-02          | 1.69E-02        | 8.45E-02               |
| Unit 3 Noble Gas                                 | 2.76E-03          | 2.76E-03        | 4.07E-03               |
| Unit 3 Particulate and Iodine                    | 2.55E-03          | 7.54E-03        | 2.57E-03               |
| Unit 3 C-14                                      | 4.49E-02          | 4.49E-02        | 2.25E-01               |
| Unit 4 Noble Gas                                 | 3.28E-02          | 3.28E-02        | 4.83E-02               |
| Unit 4 Particulate and Iodine                    | 2.44E-03          | 3.11E-03        | 2.00E-04               |
| Unit 4 C-14                                      | 3.91E-02          | 3.91E-02        | 1.96E-01               |
| <b>Total Gaseous</b>                             | <b>1.63E-01</b>   | <b>1.52E-01</b> | <b>6.50E-01</b>        |
| <b>Liquid</b>                                    |                   |                 |                        |
| Unit 1   | 2.57E-02          | 2.41E-02        | 2.66E-02               |
| Unit 2   | 1.50E-02          | 1.42E-02        | 1.55E-02               |
| Unit 3   | 1.01E-01          | 1.04E-01        | 1.02E-01               |
| Unit 4   | 7.84E-02          | 7.78E-02        | 7.96E-02               |
| <b>Total Liquid</b>                              | <b>2.20E-01</b>   | <b>2.20E-01</b> | <b>2.24E-01</b>        |
| Direct Shine*                                    | N/A               | N/A             | N/A                    |
| <b>Total w/Other Nearby Facility<sup>2</sup></b> | <b>3.30E-01</b>   | <b>3.30E-01</b> | <b>3.30E-01</b>        |
| Total Dose                                       | 7.13E-01          | 7.02E-01        | 1.20E+00               |
|  |                   |                 |                        |
| <b>% of Limit</b>                                | <b>2.85</b>       | <b>0.94</b>     | <b>4.81</b>            |

\* Based on data from the Radiological Environmental Monitoring Program, direct radiation at the site boundary is indistinguishable from background at the plant perimeter.

<sup>1</sup> Table 4 is a summation of Units to show compliance with 40 CFR Part 190 Limits.

<sup>2</sup> Savannah River Site 2024 Environmental Report Summary.

### 3.0 INTRODUCTION

#### 3.1 About Nuclear Power

Commercial nuclear power plants are generally classified as either Boiling Water Reactors (BWRs) or Pressurized Water Reactors (PWRs), based on their design. A BWR includes a single coolant system where water used as reactor coolant boils as it passes through the core and the steam generated is used to turn the turbine generator for power production. A PWR, in contrast, includes two separate water systems: radioactive reactor coolant and a secondary system. Reactor coolant is maintained under high pressure, preventing boiling. The high-pressure coolant is passed through a heat exchanger called a steam generator where the secondary system water is boiled, and the steam is used to turn the turbine generator for power production.

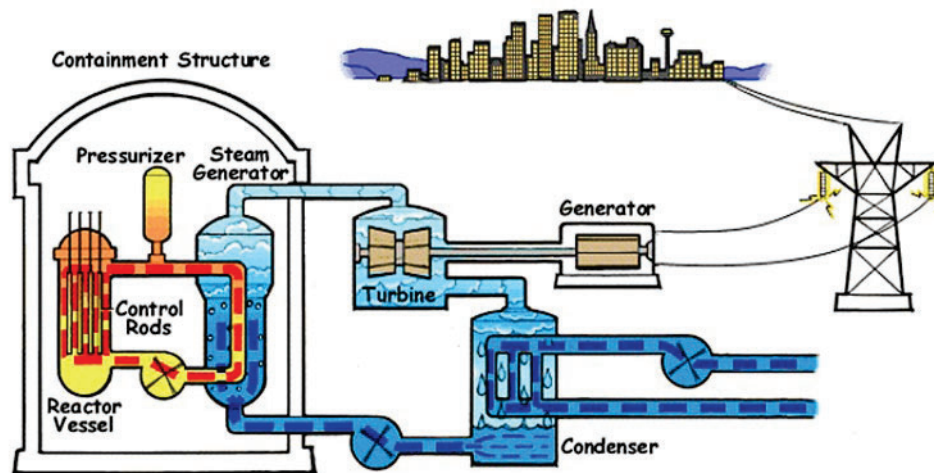

Figure 1, Pressurized Water Reactor (PWR) [1]

## 3.1 (Continued)

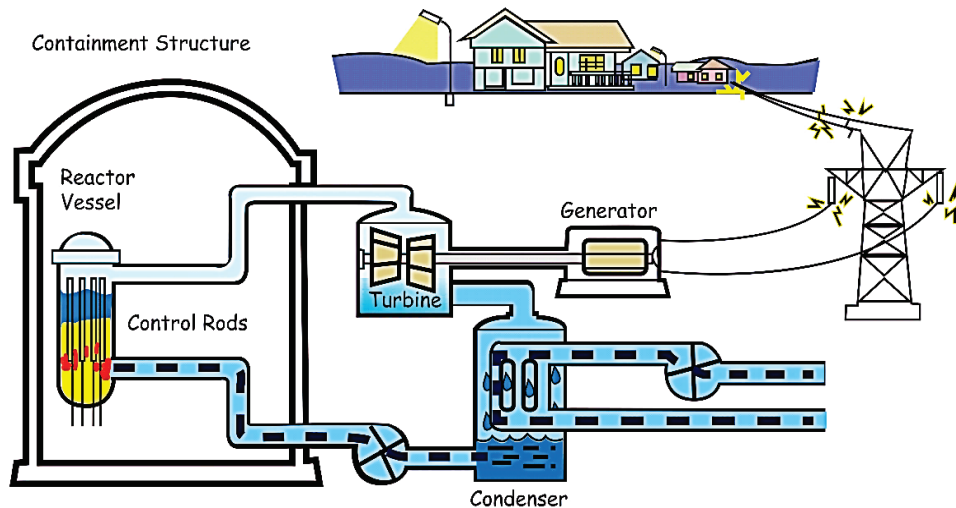

Figure 2, Boiling Water Reactor (BWR) [2]

Electricity is generated by a nuclear power plant similarly to the way that electricity is generated at other conventional types of power plants, such as those driven by coal or natural gas. Water is boiled to generate steam; the steam turns a turbine that is attached to a generator and the steam is condensed back into water to be returned to the boiler. What makes nuclear power different from these other types of power plants is that the heat is generated by fission and decay reactions occurring within and around the core containing fissionable uranium (U-235).

Nuclear fission occurs when certain nuclides (primarily U-233, U-235, or Pu-239) absorb a neutron and break into several smaller nuclides (called fission products) as well as some additional neutrons.

Fission results in production of radioactive materials including gases and solids that must be contained to prevent release or treated prior to release. These effluents are generally treated by filtration and/or hold-up prior to release. Releases are generally monitored by sampling and by continuously indicating radiation monitors. The effluent release data is used to calculate doses in order to ensure that dose to the public due to plant operation remains within required limits.

### 3.2 About Radiation Dose

Ionizing radiation, including alpha, beta, and gamma radiation from radioactive decay, has enough energy to break chemical bonds in tissues and result in damage to tissue or genetic material. The amount of ionization that will be generated by a given exposure to ionizing radiation is quantified as dose. Radiation dose is generally reported in units of millirem (mrem) in the US.

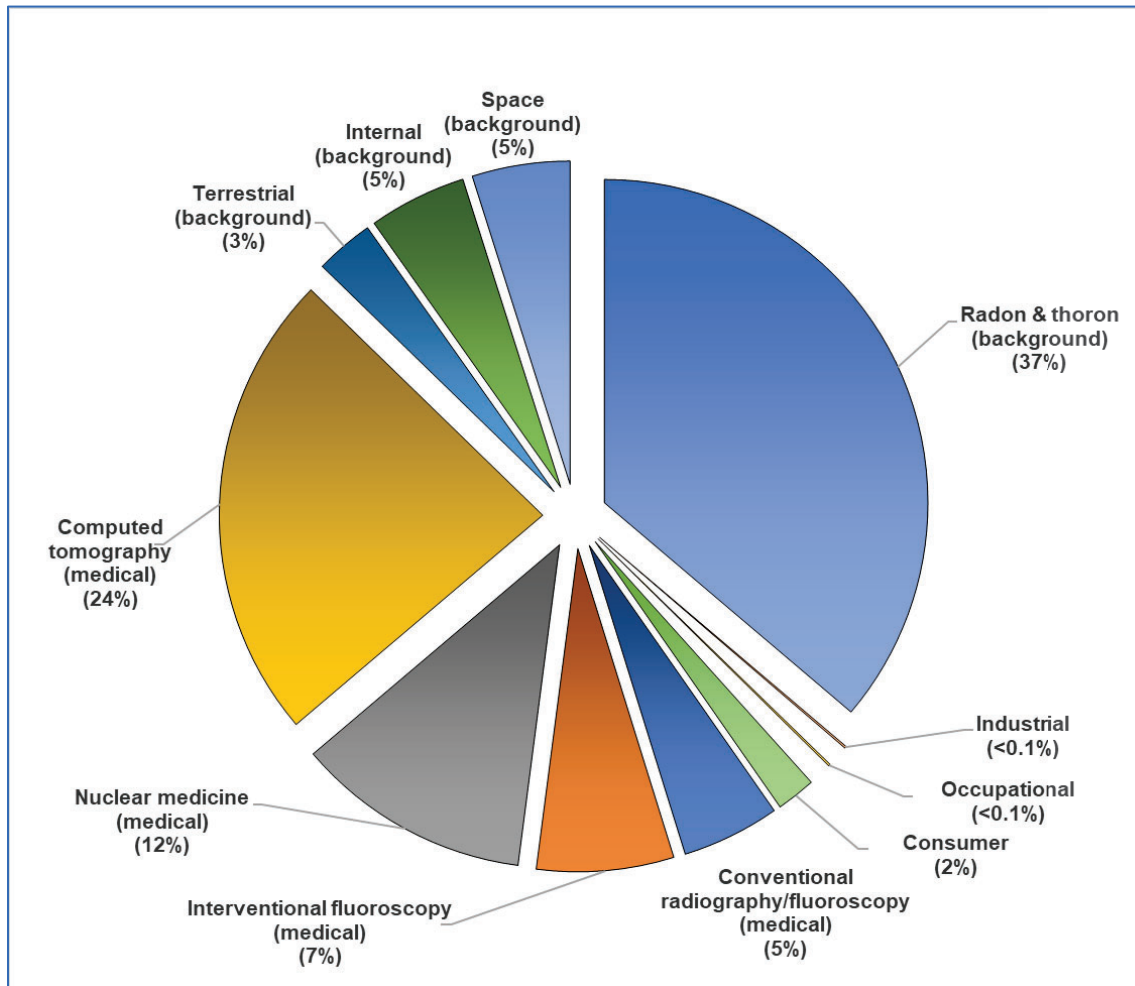

Figure 3, Sources of Radiation Exposure (NCRP Report No. 160) [3]

|  |  |               |
|--|--|---------------|
| Annual Radioactive Effluent Release Report | YEAR: 2025   | Page 15 of 81 |
| <b>Company: Southern Nuclear Company</b>   | <b>Plant: Vogtle Electric Generating Plant 1&amp;2</b> |               |

3.2 (Continued)

The National Council on Radiation Protection (NCRP) has evaluated the population dose for the US and determined that the average individual is exposed to approximately 620 mrem per year [3]. There are many sources for radiation dose, ranging from natural background sources to medical procedures, air travel, and industrial processes. Approximately half (310 mrem) of the average exposure is due to natural sources of radiation including exposure to Radon, cosmic radiation, and internal radiation and terrestrial due to naturally occurring radionuclides. The remaining 310 mrem of exposure is due to man-made sources of exposure, with the most significant contributors being medical (48%) due to radiation used in various types of medical scans and treatments. Of the remaining 2% of dose, most is due to consumer activities such as air travel, smoking cigarettes, and building materials. A small fraction of this 2% is due to industrial activities including generation of nuclear power.

Readers that are curious about common sources and effects of radiation dose that they may encounter can find excellent sources of information from the Health Physics Society, including the Radiation Fact Sheets [4], and from the US Nuclear Regulatory Commission website [5].

### 3.3 About Dose Calculation

Concentrations of radioactive material in the environment resulting from plant operations are very small and it is not possible to determine doses directly using measured activities of environmental samples. To overcome this, Dose Calculations based on measured activities of effluent streams are used to model the dose impact for Members of the Public due to plant operation and effluents. There are several mechanisms that can result in dose to Members of the Public, including: Ingestion of radionuclides in food or water; Inhalation of radionuclides in air; Immersion in a plume of noble gases; and Direct Radiation from the ground, the plant or from an elevated plume.

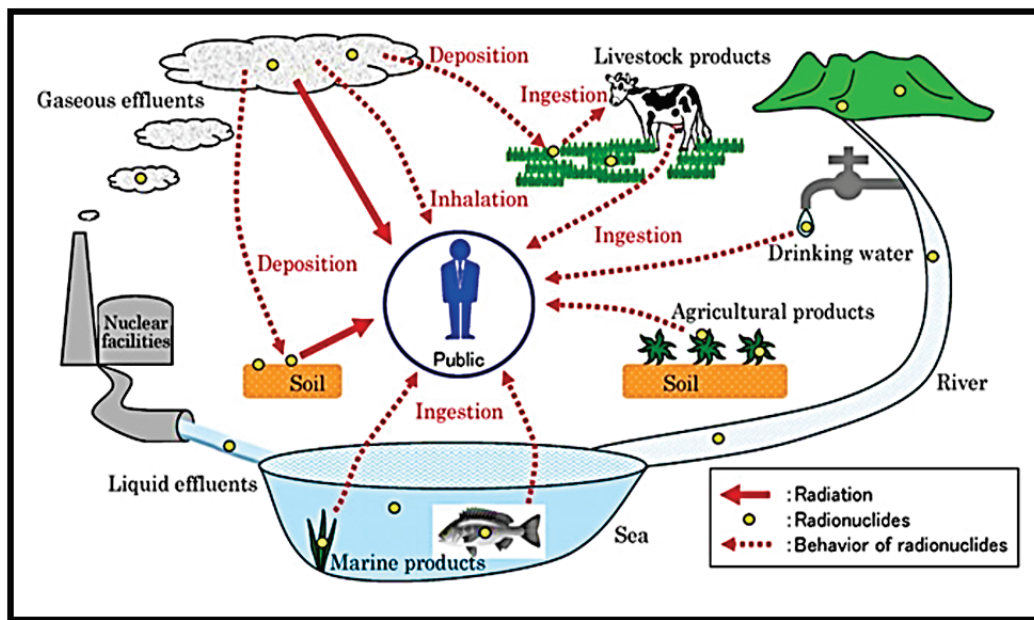

Figure 4, Potential exposure pathways to Members of the Public due to Plant Operations [6]

The Offsite Dose Calculation Manual (ODCM) specifies the methodology used to obtain the doses in the Dose Assessment section of this report. The methodology in the ODCM is based on NRC Regulatory Guide 1.109 [7] and NUREG-0133 [8]. Doses are calculated by determining what the nuclide concentration will be in air, water, on the ground, or in food products based on plant effluent releases. Release points are continuously monitored to quantify what concentrations of nuclides are being released. For gaseous releases meteorological data is used to determine how much of the released activity will be present at a given location outside of the plant either deposited onto the ground or in gaseous form. Intake patterns and nuclide bio-concentration factors are used to determine how much activity will be transferred into animal milk or meat. Finally, human ingestion factors and dose factors are used to determine how much activity will be consumed and how much dose the consumer will receive. Inhalation dose is calculated by determining the concentration of nuclides and how much air is breathed by the individual.

### 3.3 (Continued)

For liquid releases, dilution and mixing factors are used to model the environmental concentrations in water. Drinking water pathways are modeled by determining the concentration of nuclides in the water at the point where the drinking water is sourced. Fish and invertebrate pathways are determined by using concentration at the release point, bioaccumulation factors for the fish or invertebrate and an estimate of the quantity of fish consumed.

Each year a Land Use Census is performed to determine what potential dose pathways currently exist within a five-mile radius around the plant, the area most affected by plant operations. The Annual Land Use Census identifies the locations of vegetable gardens, nearest residences, milk animals and meat animals. The data from the census is used to determine who is the likely to be most exposed to radiation dose as a result of plant operation.

There is significant uncertainty in dose calculation results, due to modeling dispersion of material released and bioaccumulation factors, as well as assumptions associated with consumption and land-use patterns. Even with these sources of uncertainty, the calculations do provide a reasonable estimate of the order of magnitude of the exposure. Conservative assumptions are made in the calculation inputs such as the number of various foods and water consumed, the amount of air inhaled, and the amount of direct radiation exposure from the ground or plume, such that the actual dose received are likely lower than the calculated dose. Even with the built-in conservatism, doses calculated for the highest hypothetical exposed individual due to plant operation are a very small fraction of the annual dose that is received due to other sources. The low calculated doses due to plant effluents, along with REMP results, serve to provide assurance that the site is not having a negative impact on the environment or people living near the plant.

## 4.0 DOSE ASSESSMENT FOR PLANT OPERATIONS

### 4.1 Regulatory Limits

Regulatory limits are detailed in Station Licensing documents such as the Offsite Dose Calculation Manual (ODCM) and Technical Specifications 5.5.1, 5.5.4, 5.5.12 and 5.6.3. These documents contain the limits to which VEGP must adhere. VEGP drives to maintain the philosophy to keep dose "as low as reasonably achievable" (ALARA) and actions are taken to reduce the amount of radiation released to the environment. Liquid and gaseous release data show that the dose from VEGP is well below the ODCM limits. The concentration of liquid radioactive material released shall be limited to ten times the concentration specified in 10 CFR 20, Appendix B, Table 2, Column 2, for radionuclides other than dissolved or entrained noble gases. For dissolved or entrained noble gases, the total concentration released shall be limited to  $1.0 \times 10^{-4}$  microcuries/ml. For gross alpha in liquid radwaste, the ECL is  $2E-09$  uCi/ml. These data reveals that the radioactive effluents have an overall minimal dose contribution to the surrounding environment.

The annual whole body, skin and organ dose was computed using the 2025 source term using the dose calculation methodology provided in the ODCM. The calculated doses due to gaseous effluents to demonstrate compliance with offsite dose limits are presented in Table 1, Vogtle Electric Generating Plant 1&2 (Unit 1) Dose Summary, Table 2, Vogtle Electric Generating Plant 1&2 (Unit 2) Dose Summary and Table 4, Total Annual Offsite-Dose Comparison to 40 CFR 190 Limits for VEGP.

### 4.2 Regulatory Limits for Gaseous Effluent Doses:

1. Fission and activation gases:
  - a. Noble gases dose rate due to radioactive materials released in gaseous effluents from the site to areas at and beyond the site boundary shall be limited to the following:
    - 1) Less than or equal to 500 mrem/year to the total body
    - 2) Less than or equal to 3000 mrem/year to the skin
  - b. Noble gas air dose due to noble gases released in gaseous effluents, from each reactor unit to areas at and beyond the site boundary shall be limited to the following:
    - 1) Quarterly
      - a) Less than or equal to 5 mrad gamma
      - b) Less than or equal to 10 mrad beta

## 4.2 (Continued)

- 2) Yearly
  - a) Less than or equal to 10 mrad gamma
  - b) Less than or equal to 20 mrad beta
2. Iodine, tritium, and all radionuclides in particulate form with half-lives greater than 8 days.
  - a. The dose rate for iodine-131, iodine-133, tritium, and all radionuclides in particulate form with half-lives greater than 8 days in gaseous effluents released from the site to areas at and beyond the site boundary shall be limited to the following:
    - 1) Less than or equal to 1500 mrem/yr to any organ
  - b. The dose to a MEMBER OF THE PUBLIC from iodine-131, iodine-133, tritium, and all radionuclides in particulate form with half-lives greater than 8 DAYS in gaseous effluents released, from each reactor unit to areas at and beyond the site boundary shall be limited to the following:
    - 1) Quarterly
      - a) Less than or equal to 7.5 mrem to any organ
    - 2) Yearly
      - a) Less than or equal to 15 mrem to any organ

**4.3 Regulatory Limits for Liquid Effluent Doses**

1. The dose or dose commitment to a MEMBER OF THE PUBLIC from radioactive materials in liquid effluents released, from each reactor unit to unrestricted areas shall be limited to the following:
  - a. Quarterly
    - 1) Less than or equal to 1.5 mrem total body
    - 2) Less than or equal to 5 mrem critical organ
  - b. Yearly
    - 1) Less than or equal to 3 mrem total body
    - 2) Less than or equal to 10 mrem critical organ

#### 4.4 40 CFR 190 Regulatory Dose Limits for a Member of the Public

##### 1. Total Dose (40 CFR 190)

- a. The annual (calendar year) dose or dose commitment to any MEMBER OF THE PUBLIC in the unrestricted area due to releases of radioactivity and to radiation from uranium fuel cycle sources shall be limited to the following:
  - 1) Less than or equal to 25 mrem, Total Body or any Organ except Thyroid.
  - 2) Less than or equal to 75 mrem, Thyroid.

#### 4.5 Onsite Doses (Within Site Boundary)

ODCM 7.2.2.3 states in part:

"The report shall also include assessment of the radiation doses from radioactive liquid and gaseous effluents to MEMBERS OF THE PUBLIC due to their activities inside the SITE BOUNDARY during the report period; this assessment must be performed in accordance with Chapter 6. All assumptions used in making these assessments (i.e., specific activity, exposure time, and location) shall be included in the report".

This section evaluates dose to non-occupationally exposed workers and members of the public that may be onsite for various reasons. The report must include any other information as may be required by the Commission to estimate maximum potential annual radiation doses to the public resulting from effluent releases as required by 10 CFR 50.36a(a)(2). While within controlled or restricted areas, the limits from Sections 4.1 through 4.4 do not apply; however, 10 CFR 20.1301 dose limit of 100 mrem per year TEDE and dose rate limit of 2 mrem per hour from external sources continue to apply. Occupancy times within the controlled areas are generally sufficiently low to compensate for increase in the atmospheric dispersion factor above the site boundary. Groups of concern and occupancy factors (number of hours/year spent inside the site boundary), are listed in Table 5. These groups conservatively represent the most-exposed individual.

The location of concern within the site boundary is the Visitors Center. The activities at the Visitor Center consist of occasional attendance at meetings and/or short visits for informational purposes.

There will be no radiation dose at these locations due to radioactive liquid effluents. Delineated in Table 5 for these locations are the values of the basic data assumed in the dose assessment due to radioactive gaseous effluents. Listed in this table are distance, direction from a point midway between the center of Unit 1 and the Unit 2 reactors and the estimated maximum occupancy factor for an individual.

**Table 5, Onsite Doses (Within Site Boundary)**

| Location         | Sector | Occupancy Hours | Approx. Distance (Meters) | Dose (mrem) |          |
|------------------|--------|-----------------|---------------------------|-------------|----------|
|                  |        |                 |                           | Total Body  | Organ    |
| Visitor's Center | SE     | 4               | 447                       | 2.35E-08    | 2.35E-08 |

**5.0 SUPPLEMENTAL INFORMATION**

**5.1 Gaseous Batch Releases**

**5.1.1 VEGP (Unit 1)**

|                                     | Units   | 1 <sup>st</sup> Quarter | 2 <sup>nd</sup> Quarter | 3 <sup>rd</sup> Quarter | 4 <sup>th</sup> Quarter | Annual   |
|-------------------------------------|---------|-------------------------|-------------------------|-------------------------|-------------------------|----------|
| 1. Number of Batch Releases         |         | 62                      | 66                      | 65                      | 73                      | 266      |
| 2. Total duration of batch releases | minutes | 3.45E+03                | 5.25E+03                | 3.78E+03                | 3.48E+03                | 1.60E+04 |
| 3. Maximum batch release duration   | minutes | 1.95E+02                | 5.11E+02                | 3.90E+02                | 3.66E+02                | 5.11E+02 |
| 4. Average batch release duration   | minutes | 5.57E+01                | 7.96E+01                | 5.81E+01                | 4.76E+01                | 6.00E+01 |
| 5. Minimum batch release duration   | minutes | 1.70E+01                | 2.90E+01                | 2.10E+01                | 1.40E+01                | 1.40E+01 |

**5.1.2 VEGP (Unit 2)**

|                                     | Units   | 1 <sup>st</sup> Quarter | 2 <sup>nd</sup> Quarter | 3 <sup>rd</sup> Quarter | 4 <sup>th</sup> Quarter | Annual   |
|-------------------------------------|---------|-------------------------|-------------------------|-------------------------|-------------------------|----------|
| 1. Number of Batch Releases         |         | 50                      | 37                      | 31                      | 31                      | 149      |
| 2. Total duration of batch releases | minutes | 3.22E+04                | 3.09E+03                | 1.33E+03                | 1.32E+03                | 3.80E+04 |
| 3. Maximum batch release duration   | minutes | 4.57E+03                | 6.63E+02                | 7.40E+01                | 1.02E+02                | 4.57E+03 |
| 4. Average batch release duration   | minutes | 6.45E+02                | 8.34E+01                | 4.28E+01                | 4.25E+01                | 2.55E+02 |
| 5. Minimum batch release duration   | minutes | 1.60E+01                | 1.80E+01                | 2.00E+01                | 2.30E+01                | 1.60E+01 |

## 5.2 Liquid Batch Releases

### 5.2.1 VEGP (Unit 1)

| VEGP (Unit 1)  | Units   | 1 <sup>st</sup> Quarter | 2 <sup>nd</sup> Quarter | 3 <sup>rd</sup> Quarter | 4 <sup>th</sup> Quarter | Annual   |
|--|---------|-------------------------|-------------------------|-------------------------|-------------------------|----------|
| 1. Number of Batch Releases  |         | 17                      | 7                       | 4                       | 4                       | 32       |
| 2. Total duration of batch releases  | minutes | 5.78E+03                | 2.75E+03                | 1.14E+03                | 1.04E+03                | 1.07E+04 |
| 3. Maximum batch release duration  | minutes | 7.17E+02                | 9.41E+02                | 4.11E+02                | 4.52E+02                | 9.41E+02 |
| 4. Average batch release duration  | minutes | 3.40E+02                | 3.92E+02                | 2.85E+02                | 2.61E+02                | 3.35E+02 |
| 5. Minimum batch release duration  | minutes | 1.60E+01                | 2.16E+02                | 1.53E+02                | 7.10E+01                | 1.60E+01 |
| 6. Average stream flow during periods of release of liquid effluent into a flowing stream <sup>1</sup> | CFS     | 7.64E+03                | 1.05E+04                | 9.31E+03                | 6.46E+02                | 2.81E+04 |

### 5.2.2 VEGP (Unit 2)

| VEGP (Unit 2)  | Units   | 1 <sup>st</sup> Quarter | 2 <sup>nd</sup> Quarter | 3 <sup>rd</sup> Quarter | 4 <sup>th</sup> Quarter | Annual   |
|--|---------|-------------------------|-------------------------|-------------------------|-------------------------|----------|
| 1. Number of Batch Releases  |         | 13                      | 7                       | 5                       | 3                       | 28       |
| 2. Total duration of batch releases  | minutes | 5.99E+03                | 2.39E+03                | 1.69E+03                | 8.55E+02                | 1.09E+04 |
| 3. Maximum batch release duration  | minutes | 9.34E+02                | 5.37E+02                | 5.15E+02                | 3.74E+02                | 9.34E+02 |
| 4. Average batch release duration  | minutes | 4.61E+02                | 3.41E+02                | 3.38E+02                | 2.85E+02                | 3.90E+02 |
| 5. Minimum batch release duration  | minutes | 1.68E+02                | 2.72E+02                | 1.90E+02                | 2.29E+02                | 1.68E+02 |
| 6. Average stream flow during periods of release of liquid effluent into a flowing stream <sup>2</sup> | CFS     | 7.64E+03                | 1.05E+04                | 9.31E+03                | 6.46E+02                | 2.81E+04 |

## 5.3 Abnormal Releases

### 5.3.1 Gaseous Abnormal Releases (Unit 1)

|                                    | Units   | 1 <sup>st</sup> Quarter | 2 <sup>nd</sup> Quarter | 3 <sup>rd</sup> Quarter | 4 <sup>th</sup> Quarter | Annual   |
|------------------------------------|---------|-------------------------|-------------------------|-------------------------|-------------------------|----------|
| 1. Number of Releases              |         | 0                       | 0                       | 0                       | 0                       | 0        |
| 2. Total Time For All Releases     | minutes | 0.00E+00                | 0.00E+00                | 0.00E+00                | 0.00E+00                | 0.00E+00 |
| 3. Maximum Time For A Release      | minutes | 0.00E+00                | 0.00E+00                | 0.00E+00                | 0.00E+00                | 0.00E+00 |
| 4. Average Time For A Release      | minutes | 0.00E+00                | 0.00E+00                | 0.00E+00                | 0.00E+00                | 0.00E+00 |
| 5. Minimum Time For A Release      | minutes | 0.00E+00                | 0.00E+00                | 0.00E+00                | 0.00E+00                | 0.00E+00 |
| 6. Total activity for all releases | Curies  | 0.00E+00                | 0.00E+00                | 0.00E+00                | 0.00E+00                | 0.00E+00 |

<sup>1</sup> Average river flowrate taken from USGS Monitoring Station 02197500, Savannah River at Burton's Ferry Bridge near Millhaven, GA. 32 miles

<sup>2</sup> Average river flowrate taken from USGS Monitoring Station 02197500, Savannah River at Burton's Ferry Bridge near Millhaven, GA. 32 miles

5.3.2 Gaseous Abnormal Releases (Unit 2)

|                                    | Units   | 1 <sup>st</sup> Quarter | 2 <sup>nd</sup> Quarter | 3 <sup>rd</sup> Quarter | 4 <sup>th</sup> Quarter | Annual   |
|------------------------------------|---------|-------------------------|-------------------------|-------------------------|-------------------------|----------|
| 1. Number of Releases              |         | 0                       | 0                       | 0                       | 0                       | 0        |
| 2. Total Time For All Releases     | minutes | 0.00E+00                | 0.00E+00                | 0.00E+00                | 0.00E+00                | 0.00E+00 |
| 3. Maximum Time For A Release      | minutes | 0.00E+00                | 0.00E+00                | 0.00E+00                | 0.00E+00                | 0.00E+00 |
| 4. Average Time For A Release      | minutes | 0.00E+00                | 0.00E+00                | 0.00E+00                | 0.00E+00                | 0.00E+00 |
| 5. Minimum Time For A Release      | minutes | 0.00E+00                | 0.00E+00                | 0.00E+00                | 0.00E+00                | 0.00E+00 |
| 6. Total activity for all releases | Curies  | 0.00E+00                | 0.00E+00                | 0.00E+00                | 0.00E+00                | 0.00E+00 |

There were no abnormal gaseous releases during 2025.

5.3.3 Liquid Abnormal Releases (Unit 1)

|                                    | Units   | 1 <sup>st</sup> Quarter | 2 <sup>nd</sup> Quarter | 3 <sup>rd</sup> Quarter | 4 <sup>th</sup> Quarter | Annual   |
|------------------------------------|---------|-------------------------|-------------------------|-------------------------|-------------------------|----------|
| 1. Number of Releases              |         | 0                       | 0                       | 0                       | 0                       | 0        |
| 2. Total Time For All Releases     | minutes | 0.00E+00                | 0.00E+00                | 0.00E+00                | 0.00E+00                | 0.00E+00 |
| 3. Maximum Time For A Release      | minutes | 0.00E+00                | 0.00E+00                | 0.00E+00                | 0.00E+00                | 0.00E+00 |
| 4. Average Time For A Release      | minutes | 0.00E+00                | 0.00E+00                | 0.00E+00                | 0.00E+00                | 0.00E+00 |
| 5. Minimum Time For A Release      | minutes | 0.00E+00                | 0.00E+00                | 0.00E+00                | 0.00E+00                | 0.00E+00 |
| 6. Total activity for all releases | Curies  | 0.00E+00                | 0.00E+00                | 0.00E+00                | 0.00E+00                | 0.00E+00 |

5.3.4 Liquid Abnormal Releases (Unit 2)

|                                    | Units   | 1 <sup>st</sup> Quarter | 2 <sup>nd</sup> Quarter | 3 <sup>rd</sup> Quarter | 4 <sup>th</sup> Quarter | Annual   |
|------------------------------------|---------|-------------------------|-------------------------|-------------------------|-------------------------|----------|
| 1. Number of Releases              |         | 0                       | 0                       | 0                       | 0                       | 0        |
| 2. Total Time For All Releases     | minutes | 0.00E+00                | 0.00E+00                | 0.00E+00                | 0.00E+00                | 0.00E+00 |
| 3. Maximum Time For A Release      | minutes | 0.00E+00                | 0.00E+00                | 0.00E+00                | 0.00E+00                | 0.00E+00 |
| 4. Average Time For A Release      | minutes | 0.00E+00                | 0.00E+00                | 0.00E+00                | 0.00E+00                | 0.00E+00 |
| 5. Minimum Time For A Release      | minutes | 0.00E+00                | 0.00E+00                | 0.00E+00                | 0.00E+00                | 0.00E+00 |
| 6. Total activity for all releases | Curies  | 0.00E+00                | 0.00E+00                | 0.00E+00                | 0.00E+00                | 0.00E+00 |

There were no abnormal liquid releases during 2025.

5.4 Land Use Census Changes

There were no changes to receptors, receptor locations, sample media availability, or new (or changed) routes of exposure as determined by the 2025 Land Use Census.

## 5.5 Meteorological Data

ODCM 7.2.2.2 states in part:

The Radioactive Effluent Release Report shall include an annual summary of hourly meteorological data collected over the previous year. This annual summary may be either in the form of an hour-by-hour listing of wind speed, wind direction, atmospheric stability, and precipitation (if measured) on magnetic tape; or in the form of joint frequency distributions of wind speed, wind direction and atmospheric stability.

In lieu of submission with the Radioactive Effluent Release Report, the licensee has the option of retaining this summary of required meteorological data on site in a file that shall be provided to the NRC upon request.

Meteorological data accumulation was greater than 96.0% for all variables required by Regulatory Guide 1.23. At least a 90% data recovery is required by the Regulatory Guide.

## 5.6 Effluent Radiation Monitors Out of Service Greater Than 30 Days

ODCM 7.2.2.6 states in part that the report shall include deviations from the liquid and gaseous effluent monitoring instrumentation operability requirements included in Sections 2.1.1 and 3.1.1, respectively. The report shall include an explanation as to why the inoperability of liquid or gaseous effluent monitoring instrumentation was not corrected within the specified time requirement.

1. The inoperability of liquid and gaseous effluent monitors not corrected within the specified time for this reporting period is detailed below. When applicable, compensatory measures were utilized per ODCM Action Statements:
  - a. 2FT-0018(Liquid Waste Effluent Monitor Flowmeter) – This flowmeter was removed from service on 11/26/2024 for failing a flow transmitter calibration. The flow meter remains Out of Service (OOS) into 2026. The work for this flowmeter is being tracked on Work Order SNC2192650. A CR was generated when the monitor reached the 30-day mark for being OOS, CR11140491. TE1192584 Is being used to track the LTAM for design change.
  - b. ARE-16980 (Radwaste Facility Processing Plant Vent) – This monitor was removed from service on 11/23/2024 for heat trace panel A-1817-U3-016 being outside of the temperature operating range. The work was tracked under Work Order SNC2167248. The monitor was returned to service on 8/20/2025.CR11137510, generated to document rad monitor being OOS for more than 30 days.
  - c. 2RE-12839 A, B, C, D, E, F (Turbine Building Vent Stack) – This monitor was removed from service on 1/09/2025 for temperature trouble alarms and monitor operation failure. The work was tracked under Work Order SNC2276080. The monitor was returned to service on 2/25/2025. The 30 day OOS CR generated is CR11149826.

- d. 2RE-0018 (Liquid Waste Effluent Line) – This monitor was removed from service on 6/25/2025 due to a high alarm that would not clear after a pulse check. This work was tracked and repaired using Work Order SNC2638460. The rad monitor was returned to service on 9/13/2025. CR11198267 was generated to document rad monitor being OOS for 30 days.
  
- e. 2RE-0848 (Turbine Building Effluent Line) – This rad monitor was removed from service on 7/08/2025. Removed from service during COT (Calibration Operability Test); 2HV-0877A did not fully close as expected. This work is being tracked by Work Order SNC2704947. CR11203126 was generated to document rad monitor being OOS for 30 days. This rad monitor remains OOS into 2026.

**5.7 Offsite Dose Calculation Manual (ODCM) Changes**

ODCM 7.2.2.5 states in part that changes to the ODCM shall be submitted with the Radioactive Effluent Release Report. These changes may be due to changes in the radiological environmental monitoring program sampling locations as required by ODCM 4.1.1.2.3 or changes to dose calculation locations as required by ODCM 4.1.2.2.2. Land uses and dose calculation locations within five miles of VEGP must be determined by a land use census as required by ODCM 4.1.2.

| Date of Change | Revision | Section in ODCM | Description of Change   |
|----------------|----------|-----------------|---|
| January 2025   | 38       | All pages.      | Added VEGP UNITS 1 AND 2 ODCM. Added JANUARY 2025 Reason: VEGP UNITS 1 AND 2 ODCM was added to clarify that this is a unit 1 and 2 ODCM document Reason: The requirements of Tech Spec section 5.5.1 Licensee initiated changes to the ODCM shall be identified by markings in the margin of the affected pages, clearly indicating the area of the page that was changed, and shall indicate the date (i.e., month and year) the change was implemented. |

Company: Southern Nuclear Company

Plant: Vogtle Electric Generating Plant 1&amp;2

|                 |    |     |   |
|-----------------|----|-----|---|
| January<br>2025 | 38 | 4-1 | <p>Changed the following wording in Section 4.1 Limits of Operation From: The following limits are the same for both units at the site. Thus, a single program including monitoring, land use survey, and quality assurance serves both units.</p> <p>To: The following limits are the same for both VEGP units 1 and 2 and VEGP units 3 and 4 at the VEGP site. Thus, a single program including monitoring, land use survey, and quality assurance serves all four units. Reason: The REMP for VEGP 1&amp;2 and 3&amp;4 is a common program. All changes to the implementation of REMP will be controlled by the VEGP 1&amp;2 ODCM.</p> |
|-----------------|----|-----|---|

Company: Southern Nuclear Company

Plant: Vogtle Electric Generating Plant 1&amp;2

|                 |    |     |   |
|-----------------|----|-----|---|
| January<br>2025 | 38 | 4-3 | <p>Table 4-1 Radiological Environmental Monitoring Program 1. Direct Radiation: Changed the following language from: An inner ring of stations, one in each meteorological sector in the general area of the site boundary. An outer ring of stations, one in each meteorological sector at approximately 5 miles from the site. The balance of the stations to be placed in special interest areas such as population centers, nearby residences, schools, and in one or more areas to serve as control stations. To: An inner ring of 16 stations, one in each meteorological sector in the general area of the site boundary. An outer ring of 16 stations, one in each meteorological sector at approximately 5 miles from the site. The balance of the stations to be placed in special interest areas such as population centers, nearby residences, or schools. The use of control stations was eliminated. Reason: The REMP for VEGP 1&amp;2 and 3&amp;4 is a common program. Additional OSLDs were added to ensure that each of the 16 sectors was covered for all units (1&amp;2 and 3&amp;4). The changes in the reduction of the OSLD control locations are made as part of the adoption of ANSI/HPS N13.37-2014 Environmental Dosimetry - Criteria for System Design and Implementation. The need for control locations is eliminated because each location's background value will be determined, such that net dose can be determined.</p> |
|-----------------|----|-----|---|

Company: Southern Nuclear Company

Plant: Vogtle Electric Generating Plant 1&amp;2

|                 |    |     |  |
|-----------------|----|-----|--|
| January<br>2025 | 38 | 4-3 | <p>Revised Table 4-1<br/>Radiological Environmental<br/>Monitoring Program 2.<br/>Airborne Changed the<br/>following language from:<br/>Samples from 5 or more<br/>locations as follows: Three or<br/>more samples from close to<br/>the three site boundary<br/>locations, in different sectors.<br/>One sample from the vicinity<br/>of a community having the<br/>highest calculated annual<br/>average ground-level D/Q.<br/>One sample from a control<br/>location, as, for example, a<br/>population center 10 to 20<br/>miles distant and in the least<br/>prevalent wind direction. To:<br/>Samples from 4 or more<br/>locations as follows: Three<br/>samples from close to the<br/>three site boundary locations,<br/>in highest calculated annual<br/>average ground-level D/Q<br/>sectors. One sample from the<br/>vicinity of a community<br/>having the highest calculated<br/>annual average ground-level<br/>D/Q. Eliminated the control<br/>locations requirement.<br/>Reason: The removal of the<br/>Airborne Control Locations<br/>was carried out because they<br/>are no longer needed for<br/>determining if activity at the<br/>Indicator locations is natural<br/>or from the Plant. When the<br/>NRC recommended the use<br/>of control and indicator<br/>locations back in the 1960's<br/>and 70's, the United States<br/>and other nations were still<br/>performing above ground<br/>nuclear weapons testing. The<br/>last above ground test was<br/>performed by China in<br/>October 1980. Since that<br/>time the amount of gross<br/>beta activity in the air has<br/>declined significantly. In 2023<br/>the average gross beta<br/>concentration at the indicator<br/>locations and control<br/>locations were the same at<br/>21 fCi/m3 and 21 fCi/m3,<br/>respectively. The current<br/>program requires that should<br/>the individual gross beta<br/>activity exceed 10 time the</p> |
|-----------------|----|-----|--|

Company: Southern Nuclear Company

Plant: Vogtle Electric Generating Plant 1&amp;2

|              |    |     |  |
|--------------|----|-----|--|
|              |    |     | <p>average control location average, then a gamma scan must be performed on the individual samples. This action level can be established based upon historical data at about 200 fCi/m<sup>3</sup>. In addition to this requirement, the results from Vogtle units 1, 2, 3 and 4 would be compared to the other Southern Nuclear plant data to discern the source of any elevated numbers.</p>             |
| January 2025 | 38 | 4-4 | <p>Revised Table 4-1 Radiological Environmental Monitoring Program 3. Waterborne Eliminated the requirements a control location for the exposure pathway Sediment from Shoreline. Reason: NUREG 1301 Offsite Dose Calculation Manual Guidance: Standard Radiological Effluent Controls for Pressurized Water Reactors provides guidance that only a downstream location is necessary for this pathway.</p> |

Company: Southern Nuclear Company

Plant: Vogtle Electric Generating Plant 1&amp;2

|                 |    |     |   |
|-----------------|----|-----|---|
| January<br>2025 | 38 | 4-5 | <p>Revised Table 4-1<br/>Radiological Environmental<br/>Monitoring Program 4.<br/>Ingestion Changed the<br/>following language for Fish<br/>from: At least one sample of<br/>any commercially and<br/>recreationally important<br/>species in vicinity of plant<br/>discharge area. At least one<br/>sample of any species in<br/>areas not influenced by plant<br/>discharge. At least one<br/>sample of any anadromous<br/>species in vicinity of plant<br/>discharge. To: One sample of<br/>any commercially and<br/>recreationally important<br/>species (e.g., bass, sunfish,<br/>catfish) in vicinity of plant<br/>discharge area. One sample<br/>of the same species in areas<br/>not influenced by plant<br/>discharge. At least one<br/>sample of any anadromous<br/>species in vicinity of plant<br/>discharge. Reason: The<br/>language in this control was<br/>modified to reflect the<br/>language in the VEGP units 3<br/>and 4 ODCM. The REMP for<br/>VEGP 1&amp;2 and 3&amp;4 is a<br/>common program. All<br/>changes to the<br/>implementation of REMP will<br/>be controlled by the VEGP<br/>1&amp;2 ODCM.</p> |
|-----------------|----|-----|---|

Company: Southern Nuclear Company

Plant: Vogtle Electric Generating Plant 1&amp;2

|                 |    |     |  |
|-----------------|----|-----|--|
| January<br>2025 | 38 | 4-6 | <p>Revised Table 4-1<br/>Radiological Environmental<br/>Monitoring Program<br/>Notations (1) Added the<br/>following wording "This is a<br/>common program with Vogtle<br/>units 3 and 4." Reason:<br/>Clarifies that this is a<br/>common REMP Program. (2)<br/>Replaced "a<br/>thermoluminescent dosimeter<br/>(TLD)" with "an optical<br/>stimulated luminescent<br/>dosimeter (OSLD)." Reason:<br/>The devise used to measure<br/>direct radiation levels in the<br/>environment was changed<br/>from TLD to OSLD several<br/>years ago. (3) Replaced the<br/>following wording "10 times<br/>the yearly mean of control<br/>samples" with "200 fCi/m<sup>3</sup>".<br/>Reason: Item No. 4 above<br/>removed the requirement for<br/>airborne control locations<br/>because the data from the<br/>control locations and the<br/>indicator locations are<br/>approximately the same.<br/>However, the original Control<br/>had a stipulation to perform<br/>gamma spectroscopy on<br/>individual samples whenever,<br/>the gross beta results were<br/>10 times the control annual<br/>average value. Since the<br/>need for control samples are<br/>no longer needed a set value<br/>is added to require counting<br/>individual samples when their<br/>individual activity exceeds<br/>200 fCi/m<sup>3</sup> which<br/>approximates 10 time the<br/>historical average of the<br/>deleted control locations</p> |
|-----------------|----|-----|--|

Company: Southern Nuclear Company

Plant: Vogtle Electric Generating Plant 1&amp;2

|                 |    |            |  |
|-----------------|----|------------|--|
| January<br>2025 | 38 | 4-12, 4-17 | <p>Revised Table 4-4 Radiological Environmental Monitoring Locations to implement the requirements of Table 4-1 Radiological Environmental Monitoring Program. The changes were as follows: 1. Latitude and Longitude coordinates for all locations were added. 2. The distance (miles) and direction (sector) for the sampling locations from the centerpoint of VEGP units 3 and 4 reactors were added as appropriate. 3. Locations with multiple environmental pathways (i. e., OSLD, Air, and Vegetation), were repeated in that media. Reason: Improved information available for this table. This table represents the common REMP program for both VEGP units 1 and 2 and VEGP units 3 and 4. 4. Deleted the footnote "Two locations in the same sector and shown as a single sample station in Figure 4-1." Reason: Using the GPS coordinates all locations can be accurately plotted on GIS maps.</p> |
|-----------------|----|------------|--|

Company: Southern Nuclear Company

Plant: Vogtle Electric Generating Plant 1&amp;2

|                 |    |      |   |
|-----------------|----|------|---|
| January<br>2025 | 38 | 4-14 | <p>Revised Table 4-4 Radiological Environmental Monitoring Locations to implement the requirements of Table 4-1 Radiological Environmental Monitoring Program. The following locations were eliminated from the REMP. OSLD Special Interest and Control Locations Deleted the following Locations: 32 River Bank 36 GPC Waynesboro Operating Headquarters 47 Oak Grove Church 48 McBean Cemetery 51 SGA School, Sardis GA 37 Substation, Waynesboro GA 52 Oglethorp Substation, Alexander GA The remaining locations represent 20 inner ring locations, 17 outer ring locations, and 2 Special Interest Locations for a total of 39 locations. Reason: There are more OSLD locations in both the inner ring and outer ring than required because each of the four units are ensured to have coverage in each of the 16 sectors.</p> |
|-----------------|----|------|---|

Company: Southern Nuclear Company

Plant: Vogtle Electric Generating Plant 1&amp;2

|                 |    |      |  |
|-----------------|----|------|--|
| January<br>2025 | 38 | 4-13 | <p>Revised Table 4-4 Radiological Environmental Monitoring Locations to implement the requirements of Table 4-1 Radiological Environmental Monitoring Program. The following locations were eliminated from the REMP. Radioiodine and Particulates 10 MET Tower 16 Hancock Landing Road 36 GPC Waynesboro Operating Headquarters The remaining locations represent the 3 locations in the highest D/Q sectors, 2 additional elevated D/Q sectors, and 1 Special Interest Location Reason: The above locations meet the requirements of NUREG 1301. Although the above listed indicator locations are being eliminated from the routine ODCM sampling, the physical locations will be maintained to ensure that necessary power is available if needed in future. Should a significant gaseous radiological release occur from Farley, then those air monitoring locations could be installed with air sampling equipment to capture plume data occurring in those sectors and distances.</p> |
| January<br>2025 | 38 | 4-16 | <p>The two milk locations were removed from Table 4-4 because they are outside of the milk requirements of Table 4-1. (8)Added the following note to Table 4-4 under Milk "No milk farms located within 5-miles of the Site". Reason: The annual Land Use Census has consistently found no human consumption milk producing animals within five miles of the site. Several gardens on the Site have been added to measure broad leafy vegetation per the requirements of ODCM 4.1.1.2.3.</p>   |

|                 |    |                 |   |
|-----------------|----|-----------------|---|
| January<br>2025 | 38 | 4-18 to<br>4-21 | Provided updated maps for Figures 4-1 through 4-4<br>Reason: With changes in the REMP locations, updated maps are required. |
|-----------------|----|-----------------|---|

**5.8 Process Control Program (PCP) Changes**

PCP 12.1 states in part:

Licensee major initiated changes to the solid radioactive waste treatment system shall be reported to the Nuclear Regulatory Commission in the Radioactive Effluent Release Report for the period in which the change was implemented.

There were no major changes to the solid radwaste systems in the 2025 assessment period.

**5.9 Radioactive Waste Treatment System Changes**

ODCM 7.2.2.7 states in part:

As required by Sections 2.1.5 and 3.1.6, licensee initiated MAJOR CHANGES TO RADIOACTIVE WASTE TREATMENT SYSTEMS (liquid and gaseous) shall be reported to the Nuclear Regulatory Commission in the Radioactive Effluent Release Report covering the period in which the change was reviewed and accepted for implementation.

Note 1: In lieu of inclusion in the Radioactive Effluents Release Report, this same information may be submitted as part of the annual FSAR update.

There were no major changes to the gaseous or liquid radwaste systems in the 2025 assessment period.

**5.10 Other Supplemental Information**

**5.10.1 Measurements and Approximation of Total Radioactivity Gaseous Effluents**

1. Sample Collection and Analysis

Gaseous Effluents at the Vogtle Electric Generating Plant are currently confined to five paths: plant vents (Unit 1 and Unit 2), the condenser air ejector, the steam packing exhauster systems (Unit 1 and Unit 2), and the Radwaste Processing Facility (RPF).

Waste gas decay tanks are batch released through the Unit 1 plant vent. The containment purges are released through their respective plant vents.

Containment atmosphere is also released via the containment equipment hatch during periods when the equipment hatch is open with containment purge/vent being stopped. Approval was granted by the NRC to open the equipment hatch during fuel movement; a release permit is generated when the equipment hatch is opened, and the containment exhaust fan is not discharging to the plant vent. Any detected activity in the containment equipment hatch permit is included in the Ground Release Table of the effluent report.

All of the paths with the exception of the RPF can be continuously monitored for gaseous radioactivity. The RPF is equipped with an integrated-type sample collection device for collecting particulates. Plant vent, containment, steam jet air ejector, steam-packing exhauster are equipped with an integrated-type sample collection device for collecting particulates and iodines. During this reporting period, there were no continuous radioactive releases through the condenser air ejector and the steam packing exhauster system vents. Batch Waste Gas Decay Tank releases are analyzed for noble gases before each release. The containment atmosphere is analyzed for noble gases prior to each release and for tritium at least on a monthly basis.

Sample analysis results and release flow rates form the basis for calculating released quantities of radionuclide specific radioactivity, dose rates associated with gaseous releases, and cumulative doses for the current quarter and year.

With each release period and batch release, radioactivity, dose rates, and cumulative doses are calculated. Cumulative dose results are tabulated, along with the percent of the ODCM limits for each release for the current quarter and year.

Typically achieved minimum detectable concentrations for gaseous effluent sample analyses are reported in Table 21, Minimum Detectable Concentrations Gaseous Sample Analysis.

## 2. Total Quantities of Radioactivity, Dose Rates, and Cumulative Doses

### a. Fission and Activation Gases

The released radioactivity is determined from sample analysis results collected as described above and average release flow rates over the period represented by the collected sample. Dose rates due to noble gases, radioiodines, tritium, and particulates are calculated. Calculated dose rates are compared to the dose rate limits specified in ODCM 3.1.2 for noble gases, radioiodines, tritium, and particulates. Dose rate calculation methodology is presented in the ODCM.

Beta and gamma air doses due to noble gases are calculated for the location in the unrestricted area with the potential for the highest exposure due to gaseous releases. Air doses are calculated for each release period and cumulative totals are kept for each unit for the calendar quarter and year. Cumulative air doses are compared with the dose limits specified in ODCM 3.1.3. Current percent of the ODCM limits are shown on the printout for each release period. Air dose calculation methodology is presented in the ODCM.

b. Radioiodines, Tritium and Particulate Releases

The released quantities of radioiodines, tritium and particulates are determined using the weekly samples and release flow rates for the two plant vent release points.

After each quarter, the particulate filters from each plant vent are combined, for strontium analysis. Strontium concentrations are input to the composite file of the computer to be used for release dose rate and individual dose calculations.

Doses to a Member of the Public due to radioiodines, tritium and particulates are calculated for the controlling receptor, which is described in Table 3-7 of the ODCM. Doses are calculated for each release period, and cumulative totals are kept for each unit for the current calendar quarter and year. Cumulative doses are compared to the dose limits specified in ODCM 3.1.4.

Current percent of ODCM limits are shown in this report for each release period

c. Gross Alpha Release

The gross alpha release is calculated each month by counting the particulate filters for each week for gross alpha activity. The four or five weeks' numbers are then recorded on a data sheet and the activity is summed at the end of the month. This concentration is used for release calculations.

3. Total Error Estimation

The total or maximum error associated with the effluent measurement will include the cumulative errors resulting from the total operation of sampling and measurement. Because it may be very difficult to assign error terms for each parameter affecting the final measurement, detailed statistical evaluation of error are not suggested. The objective should be to obtain an overall estimate of the error associated with measurements of radioactive materials released in liquid and gaseous effluents and solid waste.

|  |  |               |
|--|--|---------------|
| Annual Radioactive Effluent Release Report | YEAR: 2025   | Page 38 of 81 |
| <b>Company: Southern Nuclear Company</b>   | <b>Plant: Vogtle Electric Generating Plant 1&amp;2</b> |               |

Estimated errors are based on errors in counting equipment calibration, counting statistics, vent-flow rates, vent sample flow rates, non-steady release rates, chemical yield factors, and sample losses for such items as charcoal cartridges. Total Error is calculated by the root mean square method. The root mean square value is the square root of the arithmetic mean (average) of the squares of the original values.

5.10.1 (Continued)

- a. Fission and activation total release was calculated from sample analysis results and release point flow rates with one sigma counting error.

|  |             |
|--|-------------|
| Sampling and statistical error in counting | 10%         |
| Counting equipment calibration             | 10%         |
| Vent flow rates                            | 10%         |
| Non-steady release rates                   | 20%         |
| <b>TOTAL ERROR</b>                         | <b>26.5</b> |

- b. I-131 releases were calculated from each weekly sample:

|                                 |            |
|---------------------------------|------------|
| Statistical error in counting   | 10%        |
| Counting equipment calibration  | 10%        |
| Vent flow rates                 | 10%        |
| Vent sample flow rates          | 50%        |
| Non-steady release rates        | 10%        |
| Losses from charcoal cartridges | 10%        |
| <b>TOTAL ERROR</b>              | <b>55%</b> |

- c. Particulates with half-lives greater than 8 day releases were calculated from sample and analysis results and release point flow rates.

|  |            |
|--|------------|
| Statistical error at MDC concentration | 10%        |
| Counting equipment calibration         | 10%        |
| Vent flow rates                        | 10%        |
| Vent sample flow rates                 | 50%        |
| Non steady release rates               | 10%        |
| <b>TOTAL ERROR</b>                     | <b>54%</b> |

5.10.1 (Continued)

- d. Total tritium releases were calculated from sample analysis results and release point flow rates.

|  |     |
|--|-----|
| Water vapor in sample stream determination | 10% |
| Vent flow rates                            | 10% |
| Counting calibration and statistics        | 10% |
| Non-steady release rates                   | 10% |
| TOTAL ERROR                                | 20% |

- e. Gross Alpha radioactivity was calculated from sample analysis results and release point flow rates.

|  |     |
|--|-----|
| Statistical error at MDC concentration | 10% |
| Counting equipment calibration         | 10% |
| Vent flow rates                        | 10% |
| Vent sample flow rates                 | 50% |
| Non steady release rates               | 10% |
| TOTAL ERROR                            | 55% |

5.10.2 Measurements and Approximation of Total Radioactivity Liquid Effluents

1. Total Radioactivity Determination

Prior to the release of any tank containing liquid radwaste, and following the required recirculation, samples are collected and analyzed in accordance with the Vogtle Electric Generating Plant Offsite Dose Calculation Manual (ODCM) Table 2-3 "Radioactive Liquid Waste Sampling and Analysis Program". A sample from each tank which is planned for release is analyzed for principal gamma emitters, I-131, and dissolved and entrained noble gases by gamma spectroscopy. Monthly and quarterly composites are prepared for analysis by extracting aliquots from each sample taken from the tanks, which are released. Liquid radwaste sample analyses are performed as follows:

|    | Measurement                        | Frequency           | Method  |
|----|------------------------------------|---------------------|---|
| 1. | Gamma Isotopic                     | Each Batch          | Gamma Spectroscopy with computerized data reduction.                        |
| 2. | Dissolved or entrained noble gases | Each Batch          | Gamma Spectroscopy with computerized data reduction                         |
| 3. | Tritium                            | Monthly Composite   | Distillation and liquid scintillation counting                              |
| 4. | Gross Alpha                        | Monthly Composite   | Gas flow proportional counting (1)  |
| 5. | Sr-89 & Sr-90                      | Quarterly Composite | Chemical separation and gas flow proportional or scintillation counting (1) |
| 6. | Fe-55                              | Quarterly Composite | Chemical separation and liquid scintillation Counting (1)                   |
| 7. | Ni-63                              | Quarterly Composite | Chemical separation and liquid scintillation Counting (1)                   |

(1) Analysis performed by an offsite laboratory

## 5.10.2 (Continued)

Gamma isotopic measurements are performed using germanium detectors with a resolution of 2.1 keV or lower. A peak search of the resulting gamma ray spectrum is performed by the computer system. Energy and net count data for all significant peaks are determined, and a quantitative reduction or MDC calculation is performed. This ensures that the MDC's are met for the nuclides specified in ODCM Chapter 10 (i.e., Mn-54, Fe-59, Co-58, Co-60, Zn-65, Mo-99, Cs-134, Cs-137, Ce-141 and Ce-144). The quantitative calculations, corrections for counting time, decay time, sample volume, sample geometry, detector efficiency, baseline counts, branching ratio and MDC calculations, are made based on the counts at the location in the spectrum where the peak for that radionuclide would be located, if present.

ECL fraction is determined using radionuclide concentrations of a tank planned for release, the most current results available for tritium, gross alpha, Sr-89, Sr-90, Fe-55 and Ni-63 and the corresponding ECL values. This ECL fraction is used, with appropriate safety factors, tolerance factors, and the minimum assured dilution stream flow to calculate maximum permissible release rates and a liquid effluent monitor setpoint. The monitor setpoint is calculated to assure that the limits of the Offsite Dose Calculation Manual (ODCM) are not exceeded.

A monitor reading in excess of the calculated setpoint results in an automatic termination of the liquid radwaste discharge. Liquid effluent discharge is also automatically terminated if the dilution stream flow rate falls below the minimum assured dilution flow rate used in the setpoint calculations and established as a setpoint on the dilution stream flow monitor.

Radionuclide concentrations, safety factors, dilution stream flow rate, and liquid effluent radiation monitor calibrations are entered into the computer and a pre-release printout is generated. If the release is not permissible, appropriate warnings will be displayed on the computer screen. If the release is permissible, it is approved by the Chemistry Department and sent to the Operations Department for release. When the release is completed, the necessary data from the release (i.e., release volume, etc.) is provided by the Operations Department to the Chemistry Department. This data is inputted to the computer and a post-release printout is generated. The post release printout contains the actual release rates, release concentrations and quantities, actual dilution flow, and calculated doses to an individual.

Typically achieved liquid effluent sample analyses minimum detectable concentrations are reported in Table 31, Minimum Detectable Concentrations-Liquid Sample Analyses.

5.10.2 (Continued)

2. Total Error Estimation

The total or maximum error associated with the effluent measurement includes the cumulative errors resulting from the total operation of sampling and measurement. Because it may be very difficult to assign error terms for each parameter affecting the final measurement, detailed statistical evaluation of error is not suggested. The objective should be to obtain an overall estimate of the error associated with measurements of radioactive materials released in effluents (Reference Reg. Guide 1.21 Rev 1). Total Error is calculated by the root mean square method. The root mean square value is the square root of the arithmetic mean (average) of the squares of the original values.

- a. Fission and activation total release was calculated from sample analysis results and release point flow rates with one sigma counting error.

|                                   |              |
|-----------------------------------|--------------|
| Sampling and statistical error    | 10%          |
| Counting equipment calibration    | 10%          |
| Tank volumes and system flow rate | 20%          |
| <b>TOTAL ERROR</b>                | <b>24.5%</b> |

- b. Total Tritium release was calculated from sample analysis results and release point volumes.

|                                   |              |
|-----------------------------------|--------------|
| Sampling and statistical error    | 10%          |
| Counting equipment calibration    | 10%          |
| Tank volumes and system flow rate | 20%          |
| <b>TOTAL ERROR</b>                | <b>24.5%</b> |

- c. Dissolved and entrained gases were calculated from sample analysis results and release point volumes.

|                                   |            |
|-----------------------------------|------------|
| Sampling and statistical error    | 20%        |
| Counting equipment calibration    | 10%        |
| Tank volumes and system flow rate | 20%        |
| <b>TOTAL ERROR</b>                | <b>30%</b> |

5.10.2 (Continued)

- d. Gross alpha radioactivity was calculated from sample analysis results and release point volumes.

|                                   |       |
|-----------------------------------|-------|
| Sampling and statistical error    | 10%   |
| Counting equipment calibration    | 10%   |
| Tank volumes and system flow rate | 20%   |
| TOTAL ERROR                       | 24.5% |

- e. Volume of waste prior to dilution was calculated from level indicators on the tanks and pump discharge flow rates and times.

|                                  |     |
|----------------------------------|-----|
| Level Indicator error            | 10% |
| Operator Interpretation of gauge | 10% |
| TOTAL ERROR                      | 14% |

- f. Volume of dilution water used was calculated from flow totalizers and pump discharge flow rates and times.

|                                  |     |
|----------------------------------|-----|
| Flow totalizer error             | 10% |
| Operator Interpretation of gauge | 10% |
| TOTAL ERROR                      | 14% |

- g. Gross alpha, Sr-89, Sr-90, Fe-55, Ni-63 and H-3 radioactivity has an additional error associated with sample compositing.

|                          |    |
|--------------------------|----|
| Compositing sample error | 5% |
|--------------------------|----|

5.10.3 Outside Temporary Tanks

ODCM 7.2.2.6 states in part that the report shall include a description of the events leading to liquid holdup tanks or gas storage tanks exceeding the limits of Technical Specifications 5.5.12.

Limits for outdoor liquid hold-up tanks used for radioactive liquids were not exceeded during this reporting period.

Limits for the gas storage tanks were not exceeded during this reporting period.

#### 5.10.4 Carbon-14

Carbon-14 (C-14) is a naturally-occurring radionuclide with a 5730 year half-life. Nuclear weapons testing in the 1950s and 1960s significantly increased the amount of C-14 in the atmosphere. Nuclear power plants also produce C-14, but the amount is infinitesimal compared to what has been distributed in the environment due to weapons testing and what is produced by natural cosmic ray interactions.

As nuclear plants have improved gaseous waste processing systems and improved fuel performance, the percentages of “principal radionuclides” in gaseous effluents have changed, and C-14 has become a larger percentage. “Principal radionuclides” are determined based on public dose contribution or the amount of activity discharged compared to other radionuclides of the same effluent type. In Revision 2 (June 2009) of Regulatory Guide 1.21 (RG 1.21), “Measuring, Evaluating, and Reporting Radioactive Material in Liquid and Gaseous Effluents and Solid Waste,” the NRC recommended re-evaluating “principal radionuclides” and reporting C-14 as appropriate. In 2010 Radioactive Effluent Release Reports, virtually all U. S. nuclear power plants started reporting C-14 amounts released and resulting doses to the maximally exposed member of the public.

Because C-14 is considered a hard-to-detect radionuclide which must be chemically separated from the effluent stream before it can be measured, RG 1.21 provides the option of calculating the C-14 source term based on power generation. The Electric Power Research Institute (EPRI) developed an accepted methodology for calculating C-14, and published the results in Technical Report 1021106 (December 2010), “Estimation of Carbon-14 in Nuclear Power Plant Gaseous Effluents.” Evaluation of C-14 in radioactive liquid effluents is not required because the quantity and dose contribution has been determined to be insignificant.

At Plant Vogtle, the annual quantity of C-14 released in gaseous effluents was estimated to be 12.08 Curies (per unit). Approximately 30% of the C-14 released is in the form of  $^{14}\text{CO}_2$  and is incorporated into plants through photosynthesis. Ingestion dose results from this pathway. The remaining 70% is estimated to be organic. Both the organic and inorganic forms of C-14 contribute to inhalation dose. A child is the maximally exposed individual, and bone dose is the highest organ dose. Using the dose calculation methodology from the Vogtle ODCM, the resulting bone dose to a child located at the controlling receptor location would be 8.46E-02 mrem in a year which is 0.56% of the regulatory limit of 15 mrem per year (per unit) to any organ due to gaseous effluents. The resulting total body dose to a child located at the controlling receptor location would be 1.69E-02 mrem in a year which is 0.11% of the regulatory limit of 15 mrem per year (per unit) total body dose due to Table 1 and Table 2)

5.10.5 Errata/Corrections to Previous ARERs

**6.0 NEI 07-07 ONSITE RADIOLOGICAL GROUNDWATER MONITORING PROGRAM**

Vogtle Electric Generating Plant 1&2 has developed a Groundwater Protection Initiative (GPI) program in accordance with NEI 07-07, Industry Ground Water Protection Initiative – Final Guidance Document [9]. The purpose of the GPI is to ensure timely detection and an effective response to situations involving inadvertent radiological releases to groundwater in order to prevent migration of licensed radioactive material off-site and to quantify impacts on decommissioning. The summary of results of 2025, VEGP GPI is located in Attachment 3, NEI 07-07 Onsite Radiological Groundwater Monitoring Program.

**6.1 Voluntary Notification**

During 2025, Vogtle Electric Generating Plant 1&2 did not make a voluntary NEI 07-07 notification to State/Local officials, NRC, and to other stakeholders required by site procedures.

|  |  |               |
|--|--|---------------|
| Annual Radioactive Effluent Release Report | YEAR: 2025   | Page 47 of 81 |
| <b>Company: Southern Nuclear Company</b>   | <b>Plant: Vogtle Electric Generating Plant 1&amp;2</b> |               |

## 7.0 BIBLIOGRAPHY

- [1] Nuclear Regulatory Commission, 30 June 2015. [Online]. Available: <http://www.nrc.gov/reading-rm/basic-ref/students/animated-pwr.html>. [Accessed October 2020].
- [2] Nuclear Regulatory Commission, 25 June 2015. [Online]. Available: <http://www.nrc.gov/reading-rm/basic-ref/students/animated-bwr.html>. [Accessed October 2020].
- [3] "NCRP Report No. 160, "Ionizing Radiation Exposure of the Population of the United States", " National Council on Radiation Protection and Measurements, Bethesda, MD, 2009.
- [4] [Online]. Available: <http://hps.org/hpspublications/radiationfactsheets.html>. [Accessed 2020].
- [5] "NRC Resource Page," [Online]. Available: <http://www.nrc.gov/about-nrc/radiation.html>. [Accessed 10 November 2020].
- [6] "Japan Atomic Energy Agency," 06 November 2020. [Online]. Available: [https://www.jaea.go.jp/english/04/ntokai/houkan/houkan\\_02.html](https://www.jaea.go.jp/english/04/ntokai/houkan/houkan_02.html).
- [7] "Regulatory Guide 1.109, "Calculation of Annual Doses to Man from Routine Releases of Reactor Effluents for the Purpose of Demonstrating Compliance with 10 CFR Part 50, Appendix I,," Nuclear Regulatory Commission, October, 1977.
- [8] "NUREG-0133, Preparation of Effluent Technical Specifications for Nuclear Power Plants," Nuclear Regulatory Commission, 1987.
- [9] "NEI 07-07 - Industry Ground Water Protection Initiative — Final Guidance Document, Rev. 1," Nuclear Energy Institute, Washington, D.C., 2019.
- [10] "Regulatory Guide 4.13, Performance, Testing, and Procedural Specifications for Thermoluminescence Dosimetry: Environmental Applications, Revision 2," Nuclear Regulatory Commission, June, 2019.
- [11] "Regulatory Guide 4.15, Quality Assurance for Radiological Monitoring Programs (Inception through Normal Operations to License Termination) -- Effluent Streams and the Environment," Nuclear Regulatory Commission, July, 2007.
- [12] "10 CFR 50 - Domestic Licensing of Production and Utilization Facilities," US Nuclear Regulatory Commission, Washington, DC.
- [13] "NUREG-0324, "XOQDOQ, Program for the Meteorological Evaluation of Routine Effluent Releases at Nuclear Power Stations,," Nuclear Regulatory Commission, September, 1977.
- [14] "NUREG-1301, "Offsite Dose Calculation Manual Guidance: Standard Radiological Effluent Controls for Pressurized Water Reactors,," .," Nuclear Regulatory Commission, April 1991.
- [15] "NUREG-1302, "Offsite Dose Calculation Manual Guidance: Standard Radiological Effluent Controls for Boiling Water Reactors,," Nuclear Regulatory Commission, April 1991.
- [16] "40 CFR Part 141, "National Primary Drinking Water Regulations,," US Environmental Protection Agency, Washington, DC..
- [17] "40 CFR 190 - Environmental Radiation Protection Standards for Nuclear Power Operation," US Environmental Protection Agency, Washington, DC.
- [18] "10 CFR 20 - Standards for Protection Against Radiation," US Nuclear Regulatory Commission, Washington, DC.

**Attachment 1, ARERR Release Summary Tables (RG-1.21 Tables)**

**1.0 GASEOUS EFFLUENTS**

Table 6, Gaseous Effluents Summation of All Releases (Unit 1)

| A. Fission & Activation Gases          | Unit    | Quarter<br>1 | Quarter<br>2 | Quarter<br>3 | Quarter<br>4 | Annual   | Est.<br>Total<br>Error % |
|--|---------|--------------|--------------|--------------|--------------|----------|--------------------------|
| 1. Total Release                       | Ci      | 8.90E-02     | 9.11E-02     | 1.12E-01     | 1.15E-01     | 4.07E-01 | 2.65E+01                 |
| 2. Average release rate for the period | μCi/sec | 1.13E-02     | 1.16E-02     | 1.42E-02     | 1.46E-02     | 1.29E-02 |                          |
| <b>B. Iodine-131</b>                   |         |              |              |              |              |          |                          |
| 1. Total Release                       | Ci      | 0.00E+00     | 0.00E+00     | 0.00E+00     | 0.00E+00     | 0.00E+00 | 5.50E+01                 |
| 2. Average release rate for the period | μCi/sec | N/A          | N/A          | N/A          | N/A          | N/A      |                          |
| <b>C. Particulates</b>                 |         |              |              |              |              |          |                          |
| 1. Total Release                       | Ci      | 9.72E-07     | 1.50E-06     | 0.00E+00     | 0.00E+00     | 2.47E-06 | 5.40E+01                 |
| 2. Average release rate for the period | μCi/sec | 1.23E-07     | 1.91E-07     | N/A          | N/A          | 7.83E-08 |                          |
| <b>D. Tritium</b>                      |         |              |              |              |              |          |                          |
| 1. Total Release                       | Ci      | 1.39E+02     | 4.54E+00     | 2.92E+00     | 4.93E+00     | 1.51E+02 | 2.00E+01                 |
| 2. Average release rate for the period | μCi/sec | 1.76E+01     | 5.75E-01     | 3.70E-01     | 6.26E-01     | 4.79E+00 |                          |
| <b>E. Gross Alpha</b>                  |         |              |              |              |              |          |                          |
| 1. Total Release                       | Ci      | 5.56E-07     | 4.53E-07     | 9.30E-07     | 8.96E-07     | 2.84E-06 | 5.50E+01                 |
| 2. Average release rate for the period | μCi/sec | 7.06E-08     | 5.75E-08     | 1.18E-07     | 1.14E-07     | 9.01E-08 |                          |
| <b>F. Carbon-14</b>                    |         |              |              |              |              |          |                          |
| 1. Total Release                       | Ci      | 3.02E+00     | 3.02E+00     | 3.02E+00     | 3.02E+00     | 1.21E+01 |                          |
| 2. Average release rate for the period | μCi/sec | 3.88E-01     | 3.84E-01     | 3.80E-01     | 3.80E-01     | 3.83E-01 |                          |

% of limit is on Table 1, Vogtle Electric Generating Plant 1&2 (Unit 1) Dose Summary

Table 7, Gaseous Effluents – Mixed Level Release Continuous Mode (Unit 1)

| Radionuclide Released  | Units     | Quarter 1       | Quarter 2       | Quarter 3       | Quarter 4       | Total for year  |
|--|-----------|-----------------|-----------------|-----------------|-----------------|-----------------|
| Fission & Activation Gases   |           |                 |                 |                 |                 |                 |
| No Nuclides Found  | Ci        | 0.00E+00        | 0.00E+00        | 0.00E+00        | 0.00E+00        | 0.00E+00        |
| <b>Total for Period</b>  | <b>Ci</b> | <b>0.00E+00</b> | <b>0.00E+00</b> | <b>0.00E+00</b> | <b>0.00E+00</b> | <b>0.00E+00</b> |
| Iodines  |           |                 |                 |                 |                 |                 |
| No Nuclides Found  | Ci        | 0.00E+00        | 0.00E+00        | 0.00E+00        | 0.00E+00        | 0.00E+00        |
| <b>Total for Period</b>  | <b>Ci</b> | <b>0.00E+00</b> | <b>0.00E+00</b> | <b>0.00E+00</b> | <b>0.00E+00</b> | <b>0.00E+00</b> |
| Particulates   |           |                 |                 |                 |                 |                 |
| Co-58  | Ci        | 9.72E-07        | 0.00E+00        | 0.00E+00        | 0.00E+00        | 9.72E-07        |
| <b>Total for Period</b>  | <b>Ci</b> | <b>9.72E-07</b> | <b>0.00E+00</b> | <b>0.00E+00</b> | <b>0.00E+00</b> | <b>9.72E-07</b> |
| Tritium  |           |                 |                 |                 |                 |                 |
| H-3  | Ci        | 1.39E+02        | 4.51E+00        | 2.87E+00        | 4.85E+00        | 1.51E+02        |
| Gross Alpha  |           |                 |                 |                 |                 |                 |
| Alpha  | Ci        | 5.56E-07        | 4.53E-07        | 9.30E-07        | 8.96E-07        | 2.84E-06        |
| If Not Detected, Nuclide is Not Reported. Zeroes in this table indicate that no radioactivity was present at detectable levels. See Table 21, Minimum Detectable Concentrations Gaseous Sample Analysis for typical minimum detectable concentrations. |           |                 |                 |                 |                 |                 |

Table 8, Gaseous Effluents – Mixed Level Release Batch Mode (Unit 1)

| Radionuclide Released  | Units     | Quarter 1       | Quarter 2       | Quarter 3       | Quarter 4       | Total for year  |
|--|-----------|-----------------|-----------------|-----------------|-----------------|-----------------|
| Fission & Activation Gases   |           |                 |                 |                 |                 |                 |
| Ar-41  | Ci        | 8.90E-02        | 7.96E-02        | 9.65E-02        | 1.10E-01        | 3.75E-01        |
| Xe-133   | Ci        | 0.00E+00        | 1.15E-02        | 1.53E-02        | 4.67E-03        | 3.15E-02        |
| Xe-135   | Ci        | 0.00E+00        | 0.00E+00        | 0.00E+00        | 5.02E-04        | 5.02E-04        |
| <b>Total for Period</b>  | <b>Ci</b> | <b>8.90E-02</b> | <b>9.11E-02</b> | <b>1.12E-01</b> | <b>1.15E-01</b> | <b>4.07E-01</b> |
| Iodines  |           |                 |                 |                 |                 |                 |
| No Nuclides Found  | Ci        | 0.00E+00        | 0.00E+00        | 0.00E+00        | 0.00E+00        | 0.00E+00        |
| <b>Total for Period</b>  | <b>Ci</b> | <b>0.00E+00</b> | <b>0.00E+00</b> | <b>0.00E+00</b> | <b>0.00E+00</b> | <b>0.00E+00</b> |
| Particulates   |           |                 |                 |                 |                 |                 |
| Co-60  | Ci        | 0.00E+00        | 1.50E-06        | 0.00E+00        | 0.00E+00        | 1.50E-06        |
| <b>Total for Period</b>  | <b>Ci</b> | <b>0.00E+00</b> | <b>1.50E-06</b> | <b>0.00E+00</b> | <b>0.00E+00</b> | <b>1.50E-06</b> |
| Tritium  |           |                 |                 |                 |                 |                 |
| H-3  | Ci        | 2.54E-02        | 2.28E-02        | 4.36E-02        | 8.51E-02        | 1.77E-01        |
| Gross Alpha  |           |                 |                 |                 |                 |                 |
| No Nuclides Found  | Ci        | 0.00E+00        | 0.00E+00        | 0.00E+00        | 0.00E+00        | 0.00E+00        |
| If Not Detected, Nuclide is Not Reported. Zeroes in this table indicate that no radioactivity was present at detectable levels. See Table 21, Minimum Detectable Concentrations Gaseous Sample Analysis for typical minimum detectable concentrations. |           |                 |                 |                 |                 |                 |

Table 9, Gaseous Effluents – Ground Level Release Continuous Mode (Unit 1)

| Radionuclide Released  | Units     | Quarter 1       | Quarter 2       | Quarter 3       | Quarter 4       | Total for year  |
|--|-----------|-----------------|-----------------|-----------------|-----------------|-----------------|
| Fission & Activation Gases   |           |                 |                 |                 |                 |                 |
| No Nuclides Found  | Ci        | 0.00E+00        | 0.00E+00        | 0.00E+00        | 0.00E+00        | 0.00E+00        |
| <b>Total for Period</b>  | <b>Ci</b> | <b>0.00E+00</b> | <b>0.00E+00</b> | <b>0.00E+00</b> | <b>0.00E+00</b> | <b>0.00E+00</b> |
| Iodines  |           |                 |                 |                 |                 |                 |
| No Nuclides Found  | Ci        | 0.00E+00        | 0.00E+00        | 0.00E+00        | 0.00E+00        | 0.00E+00        |
| <b>Total for Period</b>  | <b>Ci</b> | <b>0.00E+00</b> | <b>0.00E+00</b> | <b>0.00E+00</b> | <b>0.00E+00</b> | <b>0.00E+00</b> |
| Particulates   |           |                 |                 |                 |                 |                 |
| No Nuclides Found  | Ci        | 0.00E+00        | 0.00E+00        | 0.00E+00        | 0.00E+00        | 0.00E+00        |
| <b>Total for Period</b>  | <b>Ci</b> | <b>0.00E+00</b> | <b>0.00E+00</b> | <b>0.00E+00</b> | <b>0.00E+00</b> | <b>0.00E+00</b> |
| Tritium  |           |                 |                 |                 |                 |                 |
| No Nuclides Found  | Ci        | 0.00E+00        | 0.00E+00        | 0.00E+00        | 0.00E+00        | 0.00E+00        |
| Gross Alpha  |           |                 |                 |                 |                 |                 |
| No Nuclides Found  | Ci        | 0.00E+00        | 0.00E+00        | 0.00E+00        | 0.00E+00        | 0.00E+00        |
| If Not Detected, Nuclide is Not Reported. Zeroes in this table indicate that no radioactivity was present at detectable levels. See Table 21, Minimum Detectable Concentrations Gaseous Sample Analysis for typical minimum detectable concentrations. |           |                 |                 |                 |                 |                 |

Company: Southern Nuclear Company

Plant: Vogtle Electric Generating Plant 1&amp;2

Table 10, Gaseous Effluents – Ground Level Release Batch Mode (Unit 1)

| Radionuclide Released  | Units     | Quarter 1       | Quarter 2       | Quarter 3       | Quarter 4       | Total for year  |
|--|-----------|-----------------|-----------------|-----------------|-----------------|-----------------|
| Fission & Activation Gases   |           |                 |                 |                 |                 |                 |
| No Nuclides Found  | Ci        | 0.00E+00        | 0.00E+00        | 0.00E+00        | 0.00E+00        | 0.00E+00        |
| <b>Total for Period</b>  | <b>Ci</b> | <b>0.00E+00</b> | <b>0.00E+00</b> | <b>0.00E+00</b> | <b>0.00E+00</b> | <b>0.00E+00</b> |
| Iodines  |           |                 |                 |                 |                 |                 |
| No Nuclides Found  | Ci        | 0.00E+00        | 0.00E+00        | 0.00E+00        | 0.00E+00        | 0.00E+00        |
| <b>Total for Period</b>  | <b>Ci</b> | <b>0.00E+00</b> | <b>0.00E+00</b> | <b>0.00E+00</b> | <b>0.00E+00</b> | <b>0.00E+00</b> |
| Particulates   |           |                 |                 |                 |                 |                 |
| No Nuclides Found  | Ci        | 0.00E+00        | 0.00E+00        | 0.00E+00        | 0.00E+00        | 0.00E+00        |
| <b>Total for Period</b>  | <b>Ci</b> | <b>0.00E+00</b> | <b>0.00E+00</b> | <b>0.00E+00</b> | <b>0.00E+00</b> | <b>0.00E+00</b> |
| Tritium  |           |                 |                 |                 |                 |                 |
| H-3  | Ci        | 0.00E+00        | 0.00E+00        | 0.00E+00        | 0.00E+00        | 0.00E+00        |
| Gross Alpha  |           |                 |                 |                 |                 |                 |
| No Nuclides Found  | Ci        | 0.00E+00        | 0.00E+00        | 0.00E+00        | 0.00E+00        | 0.00E+00        |
| If Not Detected, Nuclide is Not Reported. Zeroes in this table indicate that no radioactivity was present at detectable levels. See Table 21, Minimum Detectable Concentrations Gaseous Sample Analysis for typical minimum detectable concentrations. |           |                 |                 |                 |                 |                 |

Table 11, Gaseous Effluents Summation of All Releases (Unit 2)

| A. Fission & Activation Gases          | Unit    | Quarter<br>1 | Quarter<br>2 | Quarter<br>3 | Quarter<br>4 | Annual   | Est.<br>Total<br>Error % |
|--|---------|--------------|--------------|--------------|--------------|----------|--------------------------|
| 1. Total Release                       | Ci      | 4.88E-02     | 7.37E-02     | 3.84E-02     | 4.31E-02     | 2.04E-01 | 2.65E+01                 |
| 2. Average release rate for the period | μCi/sec | 6.19E-03     | 9.35E-03     | 4.87E-03     | 5.47E-03     | 6.47E-03 |                          |
| <b>B. Iodine-131</b>                   |         |              |              |              |              |          |                          |
| 1. Total Release                       | Ci      | 0.00E+00     | 0.00E+00     | 0.00E+00     | 0.00E+00     | 0.00E+00 | 5.50E+01                 |
| 2. Average release rate for the period | μCi/sec | 0.00E+00     | 0.00E+00     | 0.00E+00     | 0.00E+00     | 0.00E+00 |                          |
| <b>C. Particulates</b>                 |         |              |              |              |              |          |                          |
| 1. Total Release                       | Ci      | 4.09E-07     | 0.00E+00     | 0.00E+00     | 5.98E-07     | 1.01E-06 | 5.40E+01                 |
| 2. Average release rate for the period | μCi/sec | 5.18E-08     | 0.00E+00     | 0.00E+00     | 7.588E-08    | 3.20E-08 |                          |
| <b>D. Tritium</b>                      |         |              |              |              |              |          |                          |
| 1. Total Release                       | Ci      | 1.47E+01     | 1.15E+01     | 2.10E+01     | 2.73E+00     | 4.99E+01 | 2.00E+01                 |
| 2. Average release rate for the period | μCi/sec | 1.87E+00     | 1.46E+00     | 2.67E+00     | 3.46E-01     | 1.58E+00 |                          |
| <b>E. Gross Alpha</b>                  |         |              |              |              |              |          |                          |
| 1. Total Release                       | Ci      | 1.36E-07     | 3.33E-07     | 6.94E-07     | 6.35E-07     | 1.80E-06 | 5.50E+01                 |
| 2. Average release rate for the period | μCi/sec | 1.72E-08     | 4.23E-08     | 8.80E-08     | 8.05E-08     | 5.71E-08 |                          |
| <b>F. Carbon-14</b>                    |         |              |              |              |              |          |                          |
| 1. Total Release                       | Ci      | 3.02E+00     | 3.02E+00     | 3.02E+00     | 3.02E+00     | 1.21E+01 |                          |
| 2. Average release rate for the period | μCi/sec | 3.88E-01     | 3.84E-01     | 3.80E-01     | 3.80E-01     | 3.84E-01 |                          |

% of limit is on Table 2, Vogtle Electric Generating Plant 1&2 (Unit 2) Dose Summary

Company: Southern Nuclear Company

Plant: Vogtle Electric Generating Plant 1&amp;2

Table 12, Gaseous Effluents – Mixed Level Release Continuous Mode (Unit 2)

| Radionuclide Released  | Units     | Quarter 1       | Quarter 2       | Quarter 3       | Quarter 4       | Total for year  |
|--|-----------|-----------------|-----------------|-----------------|-----------------|-----------------|
| Fission & Activation Gases   |           |                 |                 |                 |                 |                 |
| No Nuclides Found  | Ci        | 0.00E+00        | 0.00E+00        | 0.00E+00        | 0.00E+00        | 0.00E+00        |
| <b>Total for Period</b>  | <b>Ci</b> | <b>0.00E+00</b> | <b>0.00E+00</b> | <b>0.00E+00</b> | <b>0.00E+00</b> | <b>0.00E+00</b> |
| Iodines  |           |                 |                 |                 |                 |                 |
| No Nuclides Found  | Ci        | 0.00E+00        | 0.00E+00        | 0.00E+00        | 0.00E+00        | 0.00E+00        |
| <b>Total for Period</b>  | <b>Ci</b> | <b>0.00E+00</b> | <b>0.00E+00</b> | <b>0.00E+00</b> | <b>0.00E+00</b> | <b>0.00E+00</b> |
| Particulates   |           |                 |                 |                 |                 |                 |
| Co-58  | Ci        | 4.09E-07        | 0.00E+00        | 0.00E+00        | 0.00E+00        | 4.09E-07        |
| Sr-89  | Ci        | 0.00E+00        | 0.00E+00        | 0.00E+00        | 5.98E-07        | 5.98E-07        |
| <b>Total for Period</b>  | <b>Ci</b> | <b>4.09E-07</b> | <b>0.00E+00</b> | <b>0.00E+00</b> | <b>5.98E-07</b> | <b>1.01E-06</b> |
| Tritium  |           |                 |                 |                 |                 |                 |
| H-3  | Ci        | 1.18E+01        | 1.15E+01        | 2.10E+01        | 2.71E+00        | 4.70E+01        |
| Gross Alpha  |           |                 |                 |                 |                 |                 |
| Alpha  | Ci        | 1.36E-07        | 3.33E-07        | 6.94E-07        | 6.35E-07        | 1.80E-06        |
| If Not Detected, Nuclide is Not Reported. Zeroes in this table indicate that no radioactivity was present at detectable levels. See Table 21, Minimum Detectable Concentrations Gaseous Sample Analysis for typical minimum detectable concentrations. |           |                 |                 |                 |                 |                 |

Table 13, Gaseous Effluents – Mixed Level Release Batch Mode (Unit 2)

| Radionuclide Released  | Units     | Quarter 1       | Quarter 2       | Quarter 3       | Quarter 4       | Total for year  |
|--|-----------|-----------------|-----------------|-----------------|-----------------|-----------------|
| Fission & Activation Gases   |           |                 |                 |                 |                 |                 |
| Ar-41  | Ci        | 4.02E-02        | 3.92E-02        | 3.84E-02        | 4.31E-02        | 1.61E-01        |
| Xe-133   | Ci        | 8.21E-03        | 3.44E-02        | 0.00E+00        | 0.00E+00        | 4.26E-02        |
| Xe-135   | Ci        | 3.41E-04        | 1.49E-04        | 0.00E+00        | 0.00E+00        | 4.90E-04        |
| <b>Total for Period</b>  | <b>Ci</b> | <b>4.88E-02</b> | <b>7.37E-02</b> | <b>3.84E-02</b> | <b>4.31E-02</b> | <b>2.04E-01</b> |
| Iodines  |           |                 |                 |                 |                 |                 |
| No Nuclides Found  | Ci        | 0.00E+00        | 0.00E+00        | 0.00E+00        | 0.00E+00        | 0.00E+00        |
| <b>Total for Period</b>  | <b>Ci</b> | <b>0.00E+00</b> | <b>0.00E+00</b> | <b>0.00E+00</b> | <b>0.00E+00</b> | <b>0.00E+00</b> |
| Particulates   |           |                 |                 |                 |                 |                 |
| No Nuclides Found  | Ci        | 0.00E+00        | 0.00E+00        | 0.00E+00        | 0.00E+00        | 0.00E+00        |
| <b>Total for Period</b>  | <b>Ci</b> | <b>0.00E+00</b> | <b>0.00E+00</b> | <b>0.00E+00</b> | <b>0.00E+00</b> | <b>0.00E+00</b> |
| Tritium  |           |                 |                 |                 |                 |                 |
| H-3  | Ci        | 2.85E+00        | 1.53E-02        | 1.28E-02        | 2.61E-02        | 2.90E+00        |
| Gross Alpha  |           |                 |                 |                 |                 |                 |
| No Nuclides Found  | Ci        | 0.00E+00        | 0.00E+00        | 0.00E+00        | 0.00E+00        | 0.00E+00        |
| If Not Detected, Nuclide is Not Reported. Zeroes in this table indicate that no radioactivity was present at detectable levels. See Table 21, Minimum Detectable Concentrations Gaseous Sample Analysis for typical minimum detectable concentrations. |           |                 |                 |                 |                 |                 |

Table 14, Gaseous Effluents – Ground Level Release Continuous Mode (Unit 2)

| Radionuclide Released  | Units     | Quarter 1       | Quarter 2       | Quarter 3       | Quarter 4       | Total for year  |
|--|-----------|-----------------|-----------------|-----------------|-----------------|-----------------|
| Fission & Activation Gases   |           |                 |                 |                 |                 |                 |
| No Nuclides Found  | Ci        | 0.00E+00        | 0.00E+00        | 0.00E+00        | 0.00E+00        | 0.00E+00        |
| <b>Total for Period</b>  | <b>Ci</b> | <b>0.00E+00</b> | <b>0.00E+00</b> | <b>0.00E+00</b> | <b>0.00E+00</b> | <b>0.00E+00</b> |
| Iodines  |           |                 |                 |                 |                 |                 |
| No Nuclides Found  | Ci        | 0.00E+00        | 0.00E+00        | 0.00E+00        | 0.00E+00        | 0.00E+00        |
| <b>Total for Period</b>  | <b>Ci</b> | <b>0.00E+00</b> | <b>0.00E+00</b> | <b>0.00E+00</b> | <b>0.00E+00</b> | <b>0.00E+00</b> |
| Particulates   |           |                 |                 |                 |                 |                 |
| No Nuclides Found  | Ci        | 0.00E+00        | 0.00E+00        | 0.00E+00        | 0.00E+00        | 0.00E+00        |
| <b>Total for Period</b>  | <b>Ci</b> | <b>0.00E+00</b> | <b>0.00E+00</b> | <b>0.00E+00</b> | <b>0.00E+00</b> | <b>0.00E+00</b> |
| Tritium  |           |                 |                 |                 |                 |                 |
| No Nuclides Found  | Ci        | 0.00E+00        | 0.00E+00        | 0.00E+00        | 0.00E+00        | 0.00E+00        |
| Gross Alpha  |           |                 |                 |                 |                 |                 |
| No Nuclides Found  | Ci        | 0.00E+00        | 0.00E+00        | 0.00E+00        | 0.00E+00        | 0.00E+00        |
| If Not Detected, Nuclide is Not Reported. Zeroes in this table indicate that no radioactivity was present at detectable levels. See Table 21, Minimum Detectable Concentrations Gaseous Sample Analysis for typical minimum detectable concentrations. |           |                 |                 |                 |                 |                 |

Table 15, Gaseous Effluents – Ground Level Release Batch Mode (Unit 2)

| Radionuclide Released  | Units     | Quarter 1       | Quarter 2       | Quarter 3       | Quarter 4       | Total for year  |
|--|-----------|-----------------|-----------------|-----------------|-----------------|-----------------|
| Fission & Activation Gases   |           |                 |                 |                 |                 |                 |
| No Nuclides Found  | Ci        | 0.00E+00        | 0.00E+00        | 0.00E+00        | 0.00E+00        | 0.00E+00        |
| <b>Total for Period</b>  | <b>Ci</b> | <b>0.00E+00</b> | <b>0.00E+00</b> | <b>0.00E+00</b> | <b>0.00E+00</b> | <b>0.00E+00</b> |
| Iodines  |           |                 |                 |                 |                 |                 |
| No Nuclides Found  | Ci        | 0.00E+00        | 0.00E+00        | 0.00E+00        | 0.00E+00        | 0.00E+00        |
| <b>Total for Period</b>  | <b>Ci</b> | <b>0.00E+00</b> | <b>0.00E+00</b> | <b>0.00E+00</b> | <b>0.00E+00</b> | <b>0.00E+00</b> |
| Particulates   |           |                 |                 |                 |                 |                 |
| No Nuclides Found  | Ci        | 0.00E+00        | 0.00E+00        | 0.00E+00        | 0.00E+00        | 0.00E+00        |
| <b>Total for Period</b>  | <b>Ci</b> | <b>0.00E+00</b> | <b>0.00E+00</b> | <b>0.00E+00</b> | <b>0.00E+00</b> | <b>0.00E+00</b> |
| Tritium  |           |                 |                 |                 |                 |                 |
| H-3  | Ci        | 1.07E-01        | 0.00E+00        | 0.00E+00        | 0.00E+00        | 1.07E-01        |
| Gross Alpha  |           |                 |                 |                 |                 |                 |
| No Nuclides Found  | Ci        | 0.00E+00        | 0.00E+00        | 0.00E+00        | 0.00E+00        | 0.00E+00        |
| If Not Detected, Nuclide is Not Reported. Zeroes in this table indicate that no radioactivity was present at detectable levels. See Table 21, Minimum Detectable Concentrations Gaseous Sample Analysis for typical minimum detectable concentrations. |           |                 |                 |                 |                 |                 |

Table 16, Gaseous Effluents Summation of All Releases (Site)

| A. Fission & Activation Gases          | Unit    | Quarter<br>1 | Quarter<br>2 | Quarter<br>3 | Quarter<br>4 | Annual   | Est.<br>Total<br>Error % |
|--|---------|--------------|--------------|--------------|--------------|----------|--------------------------|
| 1. Total Release                       | Ci      | 1.38E-01     | 1.65E-01     | 1.50E-01     | 1.58E-01     | 6.11E-01 | 2.65E+01                 |
| 2. Average release rate for the period | μCi/sec | 1.75E-02     | 2.09E-02     | 1.91E-02     | 2.01E-02     | 1.94E-02 |                          |
| <b>B. Iodine-131</b>                   |         |              |              |              |              |          |                          |
| 1. Total Release                       | Ci      | 0.00E+00     | 0.00E+00     | 0.00E+00     | 0.00E+00     | 0.00E+00 | 5.50E+01                 |
| 2. Average release rate for the period | μCi/sec | 0.00E+00     | 0.00E+00     | 0.00E+00     | 0.00E+00     | 0.00E+00 |                          |
| <b>C. Particulates</b>                 |         |              |              |              |              |          |                          |
| 1. Total Release                       | Ci      | 1.38E-06     | 1.50E-06     | 0.00E+00     | 5.98E-07     | 3.48E-06 | 5.40E+01                 |
| 2. Average release rate for the period | μCi/sec | 1.75E-07     | 1.91E-07     | 0.00E+00     | 7.588E-08    | 1.10E-07 |                          |
| <b>D. Tritium</b>                      |         |              |              |              |              |          |                          |
| 1. Total Release                       | Ci      | 1.53E+02     | 1.60E+01     | 2.39E+01     | 7.66E+00     | 2.01E+02 | 2.00E+01                 |
| 2. Average release rate for the period | μCi/sec | 1.94E+01     | 2.03E+00     | 3.04E+00     | 9.72E-01     | 6.37E+00 |                          |
| <b>E. Gross Alpha</b>                  |         |              |              |              |              |          |                          |
| 1. Total Release                       | Ci      | 6.92E-07     | 7.87E-07     | 1.62E-06     | 1.53E-06     | 4.63E-06 | 5.50E+01                 |
| 2. Average release rate for the period | μCi/sec | 8.78E-08     | 9.98E-08     | 2.06E-07     | 1.94E-07     | 1.47E-07 |                          |
| <b>F. Carbon-14</b>                    |         |              |              |              |              |          |                          |
| 1. Total Release                       | Ci      | 6.04E+00     | 6.04E+00     | 6.04E+00     | 6.04E+00     | 2.42E+01 |                          |
| 2. Average release rate for the period | μCi/sec | 7.77E-01     | 7.68E-01     | 7.60E-01     | 7.60E-01     | 7.67E-01 |                          |

Table 17, Gaseous Effluents – Mixed Level Release Continuous Mode (Site)

| Radionuclide Released  | Units     | Quarter 1       | Quarter 2       | Quarter 3       | Quarter 4       | Total for year  |
|--|-----------|-----------------|-----------------|-----------------|-----------------|-----------------|
| Fission & Activation Gases   |           |                 |                 |                 |                 |                 |
| No Nuclides Found  | Ci        | 0.00E+00        | 0.00E+00        | 0.00E+00        | 0.00E+00        | 0.00E+00        |
| <b>Total for Period</b>  | <b>Ci</b> | <b>0.00E+00</b> | <b>0.00E+00</b> | <b>0.00E+00</b> | <b>0.00E+00</b> | <b>0.00E+00</b> |
| Iodines  |           |                 |                 |                 |                 |                 |
| No Nuclides Found  | Ci        | 0.00E+00        | 0.00E+00        | 0.00E+00        | 0.00E+00        | 0.00E+00        |
| <b>Total for Period</b>  | <b>Ci</b> | <b>0.00E+00</b> | <b>0.00E+00</b> | <b>0.00E+00</b> | <b>0.00E+00</b> | <b>0.00E+00</b> |
| Particulates   |           |                 |                 |                 |                 |                 |
| Co-58  | Ci        | 1.38E-06        | 0.00E+00        | 0.00E+00        | 0.00E+00        | 1.38E-06        |
| Sr-89  | Ci        | 0.00E+00        | 0.00E+00        | 0.00E+00        | 5.98E-07        | 5.98E-07        |
| <b>Total for Period</b>  | <b>Ci</b> | <b>1.38E-06</b> | <b>0.00E+00</b> | <b>0.00E+00</b> | <b>5.98E-07</b> | <b>1.98E-06</b> |
| Tritium  |           |                 |                 |                 |                 |                 |
| H-3  | Ci        | 1.50E+02        | 1.60E+01        | 2.39E+01        | 7.55E+00        | 1.97E+02        |
| Gross Alpha  |           |                 |                 |                 |                 |                 |
| Alpha  | Ci        | 6.92E-07        | 7.87E-07        | 1.62E-06        | 1.53E-06        | 4.63E-06        |
| If Not Detected, Nuclide is Not Reported. Zeroes in this table indicate that no radioactivity was present at detectable levels. See Table 21, Minimum Detectable Concentrations Gaseous Sample Analysis for typical minimum detectable concentrations. |           |                 |                 |                 |                 |                 |

Table 18, Gaseous Effluents – Mixed Level Release Batch Mode (Site)

| Radionuclide Released  | Units     | Quarter 1       | Quarter 2       | Quarter 3       | Quarter 4       | Total for year  |
|--|-----------|-----------------|-----------------|-----------------|-----------------|-----------------|
| Fission & Activation Gases   |           |                 |                 |                 |                 |                 |
| Ar-41  | Ci        | 1.29E-01        | 1.19E-01        | 1.35E-01        | 1.53E-01        | 5.36E-01        |
| Xe-133   | Ci        | 8.21E-03        | 4.59E-02        | 1.53E-02        | 4.67E-03        | 7.41E-02        |
| Xe-135   | Ci        | 3.41E-04        | 1.49E-04        | 0.00E+00        | 5.02E-04        | 9.92E-04        |
| <b>Total for Period</b>  | <b>Ci</b> | <b>1.38E-01</b> | <b>1.65E-01</b> | <b>1.50E-01</b> | <b>1.58E-01</b> | <b>6.11E-01</b> |
| Iodines  |           |                 |                 |                 |                 |                 |
| No Nuclides Found  | Ci        | 0.00E+00        | 0.00E+00        | 0.00E+00        | 0.00E+00        | 0.00E+00        |
| <b>Total for Period</b>  | <b>Ci</b> | <b>0.00E+00</b> | <b>0.00E+00</b> | <b>0.00E+00</b> | <b>0.00E+00</b> | <b>0.00E+00</b> |
| Particulates   |           |                 |                 |                 |                 |                 |
| Co-60  | Ci        | 0.00E+00        | 1.50E-06        | 0.00E+00        | 0.00E+00        | 1.50E-06        |
| <b>Total for Period</b>  | <b>Ci</b> | <b>0.00E+00</b> | <b>1.50E-06</b> | <b>0.00E+00</b> | <b>0.00E+00</b> | <b>1.50E-06</b> |
| Tritium  |           |                 |                 |                 |                 |                 |
| H-3  | Ci        | 2.88E+00        | 3.81E-02        | 5.64E-02        | 1.11E-01        | 3.09E+00        |
| Gross Alpha  |           |                 |                 |                 |                 |                 |
| No Nuclides Found  | Ci        | 0.00E+00        | 0.00E+00        | 0.00E+00        | 0.00E+00        | 0.00E+00        |
| If Not Detected, Nuclide is Not Reported. Zeroes in this table indicate that no radioactivity was present at detectable levels. See Table 21, Minimum Detectable Concentrations Gaseous Sample Analysis for typical minimum detectable concentrations. |           |                 |                 |                 |                 |                 |

Company: Southern Nuclear Company

Plant: Vogtle Electric Generating Plant 1&amp;2

Table 19, Gaseous Effluents – Ground Level Release Continuous Mode (Site)

| Radionuclide Released  | Units     | Quarter 1       | Quarter 2       | Quarter 3       | Quarter 4       | Total for year  |
|--|-----------|-----------------|-----------------|-----------------|-----------------|-----------------|
| Fission & Activation Gases   |           |                 |                 |                 |                 |                 |
| No Nuclides Found  | Ci        | 0.00E+00        | 0.00E+00        | 0.00E+00        | 0.00E+00        | 0.00E+00        |
| <b>Total for Period</b>  | <b>Ci</b> | <b>0.00E+00</b> | <b>0.00E+00</b> | <b>0.00E+00</b> | <b>0.00E+00</b> | <b>0.00E+00</b> |
| Iodines  |           |                 |                 |                 |                 |                 |
| No Nuclides Found  | Ci        | 0.00E+00        | 0.00E+00        | 0.00E+00        | 0.00E+00        | 0.00E+00        |
| <b>Total for Period</b>  | <b>Ci</b> | <b>0.00E+00</b> | <b>0.00E+00</b> | <b>0.00E+00</b> | <b>0.00E+00</b> | <b>0.00E+00</b> |
| Particulates   |           |                 |                 |                 |                 |                 |
| No Nuclides Found  | Ci        | 0.00E+00        | 0.00E+00        | 0.00E+00        | 0.00E+00        | 0.00E+00        |
| <b>Total for Period</b>  | <b>Ci</b> | <b>0.00E+00</b> | <b>0.00E+00</b> | <b>0.00E+00</b> | <b>0.00E+00</b> | <b>0.00E+00</b> |
| Tritium  |           |                 |                 |                 |                 |                 |
| No Nuclides Found  | Ci        | 0.00E+00        | 0.00E+00        | 0.00E+00        | 0.00E+00        | 0.00E+00        |
| Gross Alpha  |           |                 |                 |                 |                 |                 |
| No Nuclides Found  | Ci        | 0.00E+00        | 0.00E+00        | 0.00E+00        | 0.00E+00        | 0.00E+00        |
| If Not Detected, Nuclide is Not Reported. Zeroes in this table indicate that no radioactivity was present at detectable levels. See Table 21, Minimum Detectable Concentrations Gaseous Sample Analysis for typical minimum detectable concentrations. |           |                 |                 |                 |                 |                 |

Company: Southern Nuclear Company

Plant: Vogtle Electric Generating Plant 1&amp;2

Table 20, Gaseous Effluents – Ground Level Release Batch Mode (Site)

| Radionuclide Released  | Units     | Quarter 1       | Quarter 2       | Quarter 3       | Quarter 4       | Total for year  |
|--|-----------|-----------------|-----------------|-----------------|-----------------|-----------------|
| Fission & Activation Gases   |           |                 |                 |                 |                 |                 |
| No Nuclides Found  | Ci        | 0.00E+00        | 0.00E+00        | 0.00E+00        | 0.00E+00        | 0.00E+00        |
| <b>Total for Period</b>  | <b>Ci</b> | <b>0.00E+00</b> | <b>0.00E+00</b> | <b>0.00E+00</b> | <b>0.00E+00</b> | <b>0.00E+00</b> |
| Iodines  |           |                 |                 |                 |                 |                 |
| No Nuclides Found  | Ci        | 0.00E+00        | 0.00E+00        | 0.00E+00        | 0.00E+00        | 0.00E+00        |
| <b>Total for Period</b>  | <b>Ci</b> | <b>0.00E+00</b> | <b>0.00E+00</b> | <b>0.00E+00</b> | <b>0.00E+00</b> | <b>0.00E+00</b> |
| Particulates   |           |                 |                 |                 |                 |                 |
| No Nuclides Found  | Ci        | 0.00E+00        | 0.00E+00        | 0.00E+00        | 0.00E+00        | 0.00E+00        |
| <b>Total for Period</b>  | <b>Ci</b> | <b>0.00E+00</b> | <b>0.00E+00</b> | <b>0.00E+00</b> | <b>0.00E+00</b> | <b>0.00E+00</b> |
| Tritium  |           |                 |                 |                 |                 |                 |
| H-3  | Ci        | 1.07E-01        | 0.00E+00        | 0.00E+00        | 0.00E+00        | 1.07E-01        |
| Gross Alpha  |           |                 |                 |                 |                 |                 |
| No Nuclides Found  | Ci        | 0.00E+00        | 0.00E+00        | 0.00E+00        | 0.00E+00        | 0.00E+00        |
| If Not Detected, Nuclide is Not Reported. Zeroes in this table indicate that no radioactivity was present at detectable levels. See Table 21, Minimum Detectable Concentrations Gaseous Sample Analysis for typical minimum detectable concentrations. |           |                 |                 |                 |                 |                 |

Table 21, Minimum Detectable Concentrations Gaseous Sample Analysis

The values in this table represent *a priori* Minimum Detectable Concentrations (MDC) that are typically achieved in laboratory analyses of gaseous effluent samples

| RADIONUCLIDE | MDC       | UNITS  |
|--------------|-----------|--------|
| Kr-87        | 1.82E-08  | μCi/ml |
| Kr-88        | 2.53E-08  | μCi/ml |
| Xe-133       | 2.05E-08  | μCi/ml |
| Xe-133m      | 8.63E-08  | μCi/ml |
| Xe-135       | 7.12E-08  | μCi/ml |
| Xe-138       | 1.05E-07  | μCi/ml |
| I-131        | 7.93E-15* | μCi/ml |
| Mn-54        | 3.94E-14* | μCi/ml |
| Fe-59        | 2.45E-14* | μCi/ml |
| Co-58        | 1.39E-14* | μCi/ml |
| Co-60        | 1.75E-14* | μCi/ml |
| Zn-65        | 2.82E-14* | μCi/ml |
| Mo-99        | 9.57E-14* | μCi/ml |
| Cs-134       | 1.12E-14* | μCi/ml |
| Cs-137       | 8.71E-15* | μCi/ml |
| Ce-141       | 8.62E-15* | μCi/ml |
| Ce-144       | 2.77E-14* | μCi/ml |
| Sr-89        | 1.00E-13  | μCi/ml |
| Sr-90        | 1.00E-13  | μCi/ml |
| H-3          | 9.00E-08  | μCi/ml |
| Gross Alpha  | 1.00E-13  | μCi/ml |

\* Based on an estimated sample volume of 5.7E+08 mL for particulate filters and charcoal cartridges

## 2.0 LIQUID EFFLUENTS

Table 22, Liquid Effluents – Summation of All Releases (Unit 1)

| A. Fission & Activation Products                       | Unit   | Quarter 1 | Quarter 2 | Quarter 3 | Quarter 4 | Annual   | Est. Total Error % |
|--|--------|-----------|-----------|-----------|-----------|----------|--------------------|
| 1. Total Release                                       | Ci     | 5.06E-03  | 3.24E-03  | 6.05E-04  | 3.02E-03  | 1.19E-02 | 2.45E+01           |
| 2. Average diluted concentration                       | μCi/mL | 9.72E-10  | 1.25E-09  | 2.14E-10  | 1.56E-09  | 9.52E-10 |                    |
| <b>B. Tritium</b>                                      |        |           |           |           |           |          |                    |
| 1. Total Release                                       | Ci     | 4.56E+02  | 1.14E+02  | 8.59E+01  | 2.14E+01  | 6.77E+02 | 2.45E+01           |
| 2. Average diluted concentration                       | μCi/mL | 8.77E-05  | 4.37E-05  | 3.04E-05  | 1.11E-05  | 5.42E-05 |                    |
| <b>C. Dissolved &amp; Entrained Gases</b>              |        |           |           |           |           |          |                    |
| 1. Total Release                                       | Ci     | 1.44E-04  | 0.00E+00  | 0.00E+00  | 0.00E+00  | 1.44E-04 | 3.00E+01           |
| 2. Average diluted concentration                       | μCi/mL | 2.77E-11  | 0.00E+00  | 0.00E+00  | 0.00E+00  | 1.15E-11 |                    |
| <b>D. Gross Alpha Activity</b>                         |        |           |           |           |           |          |                    |
| 1. Total Release                                       | Ci     | 0.00E+00  | 0.00E+00  | 0.00E+00  | 0.00E+00  | 0.00E+00 | 2.45E+01           |
| <b>E. Volume of Waste Released (prior to dilution)</b> |        |           |           |           |           |          |                    |
|  | Liters | 1.93E+07  | 2.11E+07  | 1.59E+07  | 1.57E+07  | 7.20E+07 |                    |
| <b>F. Volume of Dilution Water Used During Period</b>  |        |           |           |           |           |          |                    |
|  | Liters | 5.18E+09  | 2.58E+09  | 2.82E+09  | 1.92E+09  | 1.25E+10 |                    |

% of limit is on the Table 1, Vogtle Electric Generating Plant 1&2 (Unit 1) Dose Summary

Table 23, Continuous Mode Liquid Effluents (Unit 1)

| Radionuclide Released   | Units     | Quarter 1       | Quarter 2       | Quarter 3       | Quarter 4       | Total for year  |
|---|-----------|-----------------|-----------------|-----------------|-----------------|-----------------|
| Fission and Activation Products   |           |                 |                 |                 |                 |                 |
| No Nuclides Found   | Ci        | 0.00E+00        | 0.00E+00        | 0.00E+00        | 0.00E+00        | 0.00E+00        |
| <b>Total for Period</b>   | <b>Ci</b> | <b>0.00E+00</b> | <b>0.00E+00</b> | <b>0.00E+00</b> | <b>0.00E+00</b> | <b>0.00E+00</b> |
| Tritium   |           |                 |                 |                 |                 |                 |
| H-3   | Ci        | 7.17E-02        | 4.21E-02        | 8.59E-02        | 1.26E-01        | <b>3.26E-01</b> |
| Gross Alpha   |           |                 |                 |                 |                 |                 |
| No Nuclides Found   | Ci        | 0.00E+00        | 0.00E+00        | 0.00E+00        | 0.00E+00        | 0.00E+00        |
| Entrained Gases   |           |                 |                 |                 |                 |                 |
| No Nuclides Found   | Ci        | 0.00E+00        | 0.00E+00        | 0.00E+00        | 0.00E+00        | 0.00E+00        |
| <b>Total for Period</b>   | <b>Ci</b> | <b>0.00E+00</b> | <b>0.00E+00</b> | <b>0.00E+00</b> | <b>0.00E+00</b> | <b>0.00E+00</b> |
| If Not Detected, Nuclide is Not Reported. Zeroes in this table indicate that no radioactivity was present at detectable levels. See Table 31, Minimum Detectable Concentrations-Liquid Sample Analyses for typical minimum detectable concentrations. |           |                 |                 |                 |                 |                 |

Company: Southern Nuclear Company

Plant: Vogtle Electric Generating Plant 1&amp;2

Table 24, Batch Mode Liquid Effluents (Unit 1)

| Radionuclide Released   | Units     | Quarter 1       | Quarter 2       | Quarter 3       | Quarter 4       | Total for year  |
|---|-----------|-----------------|-----------------|-----------------|-----------------|-----------------|
| <b>Fission and Activation Products</b>  |           |                 |                 |                 |                 |                 |
| Sb-125  | Ci        | 1.33E-04        | 0.00E+00        | 0.00E+00        | 1.14E-04        | 2.47E-04        |
| Co-57   | Ci        | 1.35E-05        | 0.00E+00        | 0.00E+00        | 6.82E-06        | 2.03E-05        |
| Co-60   | Ci        | 6.15E-04        | 2.46E-04        | 1.29E-04        | 5.60E-04        | 1.55E-03        |
| Co-58   | Ci        | 1.90E-03        | 1.58E-03        | 1.77E-04        | 6.61E-04        | 4.32E-03        |
| Fe-55   | Ci        | 5.88E-04        | 1.64E-04        | 1.58E-04        | 6.84E-04        | 1.59E-03        |
| Cs-137  | Ci        | 1.11E-04        | 1.18E-04        | 3.90E-06        | 1.09E-05        | 2.44E-04        |
| Ni-63   | Ci        | 1.68E-03        | 1.12E-03        | 1.33E-04        | 9.61E-04        | 3.89E-03        |
| Ag-110M   | Ci        | 0.00E+00        | 0.00E+00        | 3.24E-06        | 0.00E+00        | 3.24E-06        |
| Mn-54   | Ci        | 2.02E-05        | 1.32E-05        | 1.17E-06        | 2.52E-05        | 5.98E-05        |
| <b>Total for Period</b>   | <b>Ci</b> | <b>5.06E-03</b> | <b>3.24E-03</b> | <b>6.05E-04</b> | <b>3.02E-03</b> | <b>1.19E-02</b> |
| <b>Tritium</b>  |           |                 |                 |                 |                 |                 |
| H-3   | Ci        | 4.56E+02        | 1.14E+02        | 8.59E+01        | 2.13E+01        | 6.77E+02        |
| <b>Gross Alpha</b>  |           |                 |                 |                 |                 |                 |
| No Nuclides Found   | Ci        | 0.00E+00        | 0.00E+00        | 0.00E+00        | 0.00E+00        | 0.00E+00        |
| <b>Entrained Gases</b>  |           |                 |                 |                 |                 |                 |
| Xe-133  | Ci        | 1.44E-04        | 0.00E+00        | 0.00E+00        | 0.00E+00        | 1.44E-04        |
| <b>Total for Period</b>   | <b>Ci</b> | <b>1.44E-04</b> | <b>0.00E+00</b> | <b>0.00E+00</b> | <b>0.00E+00</b> | <b>1.44E-04</b> |
| If Not Detected, Nuclide is Not Reported. Zeroes in this table indicate that no radioactivity was present at detectable levels. See Table 31, Minimum Detectable Concentrations-Liquid Sample Analyses for typical minimum detectable concentrations. |           |                 |                 |                 |                 |                 |

Table 25, Liquid Effluents – Summation of All Releases (Unit 2)

| A. Fission & Activation Products                       | Unit   | Quarter 1 | Quarter 2 | Quarter 3 | Quarter 4 | Annual   | Est. Total Error % |
|--|--------|-----------|-----------|-----------|-----------|----------|--------------------|
| 1. Total Release                                       | Ci     | 2.13E-03  | 5.40E-04  | 2.92E-04  | 4.87E-04  | 3.45E-03 | 2.45E+01           |
| 2. Average diluted concentration                       | μCi/mL | 4.20E-10  | 2.10E-10  | 1.02E-10  | 2.54E-10  | 2.78E-10 |                    |
| <b>B. Tritium</b>                                      |        |           |           |           |           |          |                    |
| 1. Total Release                                       | Ci     | 4.03E+02  | 1.88E+02  | 6.02E+01  | 2.24E+01  | 6.74E+02 | 2.45E+01           |
| 2. Average diluted concentration                       | μCi/mL | 7.94E-05  | 7.31E-05  | 2.10E-05  | 1.17E-05  | 5.44E-05 |                    |
| <b>C. Dissolved &amp; Entrained Gases</b>              |        |           |           |           |           |          |                    |
| 1. Total Release                                       | Ci     | 5.25E-05  | 6.35E-06  | 0.00E+00  | 0.00E+00  | 5.89E-05 | 3.00E+01           |
| 2. Average diluted concentration                       | μCi/mL | 1.03E-11  | 2.47E-12  | 0.00E+00  | 0.00E+00  | 4.75E-12 |                    |
| <b>D. Gross Alpha Activity</b>                         |        |           |           |           |           |          |                    |
| 1. Total Release                                       | Ci     | 0.00E+00  | 0.00E+00  | 0.00E+00  | 0.00E+00  | 0.00E+00 | 2.45E+01           |
| <b>E. Volume of Waste Released (prior to dilution)</b> |        |           |           |           |           |          |                    |
|  | Liters | 1.73E+07  | 1.46E+07  | 1.44E+07  | 1.27E+07  | 5.90E+07 |                    |
| <b>F. Volume of Dilution Water Used During Period</b>  |        |           |           |           |           |          |                    |
|  | Liters | 5.06E+09  | 2.55E+09  | 2.86E+09  | 1.91E+09  | 1.24E+10 |                    |

% of limit is on the Table 2, Vogtle Electric Generating Plant 1&2 (Unit 2) Dose Summary

Table 26, Continuous Mode Liquid Effluents (Unit 2)

| Radionuclide Released   | Units     | Quarter 1       | Quarter 2       | Quarter 3       | Quarter 4       | Total for year  |
|---|-----------|-----------------|-----------------|-----------------|-----------------|-----------------|
| Fission and Activation Products   |           |                 |                 |                 |                 |                 |
| No Nuclides Found   | Ci        | 0.00E+00        | 0.00E+00        | 0.00E+00        | 0.00E+00        | 0.00E+00        |
| <b>Total for Period</b>   | <b>Ci</b> | <b>0.00E+00</b> | <b>0.00E+00</b> | <b>0.00E+00</b> | <b>0.00E+00</b> | <b>0.00E+00</b> |
| Tritium   |           |                 |                 |                 |                 |                 |
| H-3   | Ci        | 4.85E-02        | 3.16E-02        | 1.08E-01        | 1.32E-01        | 3.20E-01        |
| Gross Alpha   |           |                 |                 |                 |                 |                 |
| No Nuclides Found   | Ci        | 0.00E+00        | 0.00E+00        | 0.00E+00        | 0.00E+00        | 0.00E+00        |
| Entrained Gases   |           |                 |                 |                 |                 |                 |
| No Nuclides Found   | Ci        | 0.00E+00        | 0.00E+00        | 0.00E+00        | 0.00E+00        | 0.00E+00        |
| <b>Total for Period</b>   | <b>Ci</b> | <b>0.00E+00</b> | <b>0.00E+00</b> | <b>0.00E+00</b> | <b>0.00E+00</b> | <b>0.00E+00</b> |
| If Not Detected, Nuclide is Not Reported. Zeroes in this table indicate that no radioactivity was present at detectable levels. See Table 31, Minimum Detectable Concentrations-Liquid Sample Analyses for typical minimum detectable concentrations. |           |                 |                 |                 |                 |                 |

Company: Southern Nuclear Company

Plant: Vogtle Electric Generating Plant 1&amp;2

Table 27, Batch Mode Liquid Effluents (Unit 2)

| Radionuclide Released   | Units     | Quarter 1       | Quarter 2       | Quarter 3       | Quarter 4       | Total for year  |
|---|-----------|-----------------|-----------------|-----------------|-----------------|-----------------|
| <b>Fission and Activation Products</b>  |           |                 |                 |                 |                 |                 |
| Fe-55   | Ci        | 1.67E-04        | 4.41E-05        | 3.79E-05        | 8.36E-05        | 3.33E-04        |
| Mn-54   | Ci        | 8.97E-06        | 0.00E+00        | 0.00E+00        | 6.69E-06        | 1.57E-05        |
| Cs-137  | Ci        | 1.03E-04        | 4.20E-05        | 5.16E-06        | 6.22E-06        | 1.56E-04        |
| Ni-63   | Ci        | 9.28E-04        | 1.99E-04        | 9.96E-05        | 1.28E-04        | 1.35E-03        |
| Co-60   | Ci        | 2.80E-04        | 6.10E-05        | 5.17E-05        | 2.33E-04        | 6.26E-04        |
| Co-58   | Ci        | 5.46E-04        | 1.94E-04        | 9.81E-05        | 2.98E-05        | 8.68E-04        |
| Sb-125  | Ci        | 9.53E-05        | 0.00E+00        | 0.00E+00        | 0.00E+00        | 9.53E-05        |
| Co-57   | Ci        | 6.14E-06        | 0.00E+00        | 0.00E+00        | 0.00E+00        | 6.14E-06        |
| <b>Total for Period</b>   | <b>Ci</b> | <b>2.13E-03</b> | <b>5.40E-04</b> | <b>2.92E-04</b> | <b>4.87E-04</b> | <b>3.45E-03</b> |
| <b>Tritium</b>  |           |                 |                 |                 |                 |                 |
| H-3   | Ci        | 4.03E+02        | 1.88E+02        | 6.01E+01        | 2.23E+01        | 6.73E+02        |
| <b>Gross Alpha</b>  |           |                 |                 |                 |                 |                 |
| No Nuclides Found   | Ci        | 0.00E+00        | 0.00E+00        | 0.00E+00        | 0.00E+00        | 0.00E+00        |
| <b>Entrained Gases</b>  |           |                 |                 |                 |                 |                 |
| Xe-133  | Ci        | 5.25E-05        | 0.00E+00        | 0.00E+00        | 0.00E+00        | 5.25E-05        |
| Ar-41   | Ci        | 0.00E+00        | 6.35E-06        | 0.00E+00        | 0.00E+00        | 6.35E-06        |
| <b>Total for Period</b>   | <b>Ci</b> | <b>5.25E-05</b> | <b>6.35E-06</b> | <b>0.00E+00</b> | <b>0.00E+00</b> | <b>5.89E-05</b> |
| If Not Detected, Nuclide is Not Reported. Zeroes in this table indicate that no radioactivity was present at detectable levels. See Table 31, Minimum Detectable Concentrations-Liquid Sample Analyses for typical minimum detectable concentrations. |           |                 |                 |                 |                 |                 |

Table 28, Liquid Effluents – Summation of All Releases (Site)

| A. Fission & Activation Products                       | Unit   | Quarter<br>1 | Quarter<br>2 | Quarter<br>3 | Quarter<br>4 | Annual   | Est. Total<br>Error % |
|--|--------|--------------|--------------|--------------|--------------|----------|-----------------------|
| 1. Total Release                                       | Ci     | 7.19E-03     | 3.78E-03     | 8.97E-04     | 3.51E-03     | 1.54E-02 | 2.45E+01              |
| 2. Average diluted concentration                       | μCi/mL | 6.99E-10     | 7.32E-10     | 1.57E-10     | 9.10E-10     | 6.21E-07 |                       |
| <b>B. Tritium</b>                                      |        |              |              |              |              |          |                       |
| 1. Total Release                                       | Ci     | 8.60E+02     | 3.01E+02     | 1.46E+02     | 4.39E+01     | 1.35E+03 | 2.45E+01              |
| 2. Average diluted concentration                       | μCi/mL | 8.36E-05     | 5.83E-05     | 2.56E-05     | 1.14E-05     | 5.44E-02 |                       |
| <b>C. Dissolved &amp; Entrained Gases</b>              |        |              |              |              |              |          |                       |
| 1. Total Release                                       | Ci     | 1.97E-04     | 6.35E-06     | 0.00E+00     | 0.00E+00     | 2.03E-04 | 3.00E+01              |
| 2. Average diluted concentration                       | μCi/mL | 1.91E-11     | 1.23E-12     | 0.00E+00     | 0.00E+00     | 8.19E-09 |                       |
| <b>D. Gross Alpha Activity</b>                         |        |              |              |              |              |          |                       |
| 1. Total Release                                       | Ci     | 0.00E+00     | 0.00E+00     | 0.00E+00     | 0.00E+00     | 0.00E+00 | 2.45E+01              |
| <b>E. Volume of Waste Released (prior to dilution)</b> |        |              |              |              |              |          |                       |
|  | Liters | 3.65E+07     | 3.57E+07     | 3.02E+07     | 2.84E+07     | 1.31E+08 |                       |
| <b>F. Volume of Dilution Water Used During Period</b>  |        |              |              |              |              |          |                       |
|  | Liters | 1.02E+10     | 5.13E+09     | 5.68E+09     | 3.83E+09     | 2.48E+10 |                       |

% of limit is on the Table 3, Vogtle Electric Generating Plant 1&2 (Site) Dose Summary

Table 29, Continuous Mode Liquid Effluents (Site)

| Radionuclide Released   | Units     | Quarter 1       | Quarter 2       | Quarter 3       | Quarter 4       | Total for year  |
|---|-----------|-----------------|-----------------|-----------------|-----------------|-----------------|
| Fission and Activation Products   |           |                 |                 |                 |                 |                 |
| No Nuclides Found   | Ci        | 0.00E+00        | 0.00E+00        | 0.00E+00        | 0.00E+00        | 0.00E+00        |
| <b>Total for Period</b>   | <b>Ci</b> | <b>0.00E+00</b> | <b>0.00E+00</b> | <b>0.00E+00</b> | <b>0.00E+00</b> | <b>0.00E+00</b> |
| Tritium   |           |                 |                 |                 |                 |                 |
| H-3   | Ci        | 1.20E-01        | 7.37E-02        | 1.93E-01        | 2.57E-01        | 6.44E-01        |
| Gross Alpha   |           |                 |                 |                 |                 |                 |
| No Nuclides Found   | Ci        | 0.00E+00        | 0.00E+00        | 0.00E+00        | 0.00E+00        | 0.00E+00        |
| Entrained Gasses  |           |                 |                 |                 |                 |                 |
| No Nuclides Found   | Ci        | 0.00E+00        | 0.00E+00        | 0.00E+00        | 0.00E+00        | 0.00E+00        |
| <b>Total for Period</b>   | <b>Ci</b> | <b>0.00E+00</b> | <b>0.00E+00</b> | <b>0.00E+00</b> | <b>0.00E+00</b> | <b>0.00E+00</b> |
| If Not Detected, Nuclide is Not Reported. Zeroes in this table indicate that no radioactivity was present at detectable levels. See Table 31, Minimum Detectable Concentrations-Liquid Sample Analyses for typical minimum detectable concentrations. |           |                 |                 |                 |                 |                 |

Company: Southern Nuclear Company

Plant: Vogtle Electric Generating Plant 1&amp;2

Table 30, Batch Mode Liquid Effluents (Site)

| Radionuclide Released   | Units     | Quarter 1       | Quarter 2       | Quarter 3       | Quarter 4       | Total for year  |
|---|-----------|-----------------|-----------------|-----------------|-----------------|-----------------|
| <b>Fission and Activation Products</b>  |           |                 |                 |                 |                 |                 |
| Cs-137  | Ci        | 2.14E-04        | 1.60E-04        | 9.07E-06        | 1.71E-05        | 4.00E-04        |
| Co-60   | Ci        | 8.96E-04        | 3.07E-04        | 1.80E-04        | 7.93E-04        | 2.18E-03        |
| Ni-63   | Ci        | 2.61E-03        | 1.32E-03        | 2.33E-04        | 1.09E-03        | 5.25E-03        |
| Co-57   | Ci        | 1.96E-05        | 0.00E+00        | 0.00E+00        | 6.82E-06        | 2.64E-05        |
| Sb-125  | Ci        | 2.28E-04        | 0.00E+00        | 0.00E+00        | 1.14E-04        | 3.42E-04        |
| Mn-54   | Ci        | 2.91E-05        | 1.32E-05        | 1.17E-06        | 3.19E-05        | 7.54E-05        |
| Co-58   | Ci        | 2.44E-03        | 1.77E-03        | 2.75E-04        | 6.90E-04        | 5.18E-03        |
| Fe-55   | Ci        | 7.55E-04        | 2.08E-04        | 1.96E-04        | 7.68E-04        | 1.93E-03        |
| Ag-110M   | Ci        | 0.00E+00        | 0.00E+00        | 3.24E-06        | 0.00E+00        | 3.24E-06        |
| <b>Total for Period</b>   | <b>Ci</b> | <b>7.19E-03</b> | <b>3.78E-03</b> | <b>8.97E-04</b> | <b>3.51E-03</b> | <b>1.54E-02</b> |
| <b>Tritium</b>  |           |                 |                 |                 |                 |                 |
| H-3   | Ci        | 8.60E+02        | 3.01E+02        | 1.46E+02        | 4.36E+01        | 1.35E+03        |
| <b>Gross Alpha</b>  |           |                 |                 |                 |                 |                 |
| No Nuclides Found   | Ci        | 0.00E+00        | 0.00E+00        | 0.00E+00        | 0.00E+00        | 0.00E+00        |
| <b>Entrained Gases</b>  |           |                 |                 |                 |                 |                 |
| Ar-41   | Ci        | 0.00E+00        | 6.35E-06        | 0.00E+00        | 0.00E+00        | 6.35E-06        |
| Xe-133  | Ci        | 1.97E-04        | 0.00E+00        | 0.00E+00        | 0.00E+00        | 1.97E-04        |
| <b>Total for Period</b>   | <b>Ci</b> | <b>1.97E-04</b> | <b>6.35E-06</b> | <b>0.00E+00</b> | <b>0.00E+00</b> | <b>2.03E-04</b> |
| If Not Detected, Nuclide is Not Reported. Zeroes in this table indicate that no radioactivity was present at detectable levels. See Table 31, Minimum Detectable Concentrations-Liquid Sample Analyses for typical minimum detectable concentrations. |           |                 |                 |                 |                 |                 |

Table 31, Minimum Detectable Concentrations-Liquid Sample Analyses

The values in this table represent *a priori* Minimum Detectable Concentrations (MDC) that are typically achieved in laboratory analyses of liquid radwaste samples.

| RADIONUCLIDE | MDC      | UNITS  |
|--------------|----------|--------|
| Mn-54        | 2.73E-08 | μCi/ml |
| Fe-59        | 8.33E-08 | μCi/ml |
| Co-58        | 3.78E-08 | μCi/ml |
| Co-60        | 6.76E-08 | μCi/ml |
| Zn-65        | 1.32E-07 | μCi/ml |
| Mo-99        | 4.31E-07 | μCi/ml |
| Cs-134       | 3.06E-08 | μCi/ml |
| Cs-137       | 4.51E-08 | μCi/ml |
| Ce-141       | 6.99E-08 | μCi/ml |
| Ce-144       | 2.95E-07 | μCi/ml |
| I-131        | 5.97E-08 | μCi/ml |
| Xe-133       | 9.11E-08 | μCi/ml |
| Xe-135       | 4.27E-08 | μCi/ml |
| Fe-55        | 1.00E-06 | μCi/ml |
| Sr-89        | 5.00E-08 | μCi/ml |
| Sr-90        | 7.00E-09 | μCi/ml |
| H-3          | 2.00E-06 | μCi/ml |
| Gross Alpha  | 7.00E-08 | μCi/ml |

**Attachment 2, Solid Waste Information**

Table 32, Solid Waste Shipped Offsite January 1, 2025 Through June 30, 2025

**A. Solid Waste Shipped Offsite For Burial Or Disposal (Not irradiated fuel)**

| 1.Type of Waste: <b><u>NRC Waste Class A</u></b>          | <u>UNIT</u>    | <u>6 month Period</u> | <u>Est. Total ERROR %</u> |
|---|----------------|-----------------------|---------------------------|
| a) Spent resins, filter sludges, evaporator bottoms, etc. | m <sup>3</sup> | 3.75E+01              | +/- 10%                   |
|   | Ci             | 1.25E-02              | +/- 10%                   |
| b) Dry compressible waste, contaminated equip., etc.      | m <sup>3</sup> | 2.28E+02              | +/- 25%                   |
|   | Ci             | 1.28E-01              | +/- 25%                   |
| c) Irradiated components, control rods, etc.              | m <sup>3</sup> | N/A                   | N/A                       |
|   | Ci             | N/A                   | N/A                       |
| d) Control Rod Drive Filters                              | m <sup>3</sup> | N/A                   | N/A                       |
|   | Ci             | N/A                   | N/A                       |
| e) Other (describe)                                       | m <sup>3</sup> | 6.98E+01              | +/- 10%                   |
|   | Ci             | 9.77E-03              | +/- 10%                   |
| 1.Type of Waste: <b><u>NRC Waste Class B</u></b>          | <u>UNIT</u>    | <u>6 month Period</u> | <u>Est. Total ERROR %</u> |
| a) Spent resins, filter sludges, evaporator bottoms, etc. | m <sup>3</sup> | 3.65E+00              | +/- 10%                   |
|   | Ci             | 1.54E+02              | +/- 10%                   |
| b) Dry compressible waste, contaminated equip., etc.      | m <sup>3</sup> | N/A                   | N/A                       |
|   | Ci             | N/A                   | N/A                       |
| c) Irradiated components, control rods, etc.              | m <sup>3</sup> | N/A                   | N/A                       |
|   | Ci             | N/A                   | N/A                       |
| d) Control Rod Drive Filters                              | m <sup>3</sup> | N/A                   | N/A                       |
|   | Ci             | N/A                   | N/A                       |
| e) Other (describe)                                       | m <sup>3</sup> | N/A                   | N/A                       |
|   | Ci             | N/A                   | N/A                       |

**2. Estimate of Major Nuclide Composition (by type of waste): NRC Waste Class A**

|    | ISOTOPE | PERCENT | CURIES   |
|----|---------|---------|----------|
| a. | H-3     | 33.55   | 4.20E-03 |
|    | C-14    | 3.05    | 3.82E-04 |
|    | Mn-54   | 1.42    | 1.78E-04 |
|    | Fe-55   | 9.03    | 1.13E-03 |
|    | Co-58   | 23.5    | 2.94E-03 |
|    | Co-60   | 11.61   | 1.45E-03 |
|    | Ni-63   | 15.49   | 1.94E-03 |
| b. | H-3     | 33.59   | 4.29E-02 |
|    | C-14    | 3.05    | 3.90E-03 |
|    | Mn-54   | 1.43    | 1.82E-03 |
|    | Fe-55   | 9.04    | 1.16E-02 |
|    | Co-58   | 23.5    | 3.00E-02 |

|    |       |       |          |
|----|-------|-------|----------|
|    | Co-60 | 11.62 | 1.49E-02 |
|    | Ni-63 | 15.5  | 1.98E-02 |
| c. | N/A   | N/A   | N/A      |
| d. | N/A   | N/A   | N/A      |
| e. | H-3   | 34.23 | 3.35E-03 |
|    | C-14  | 3.11  | 3.04E-04 |
|    | Mn-54 | 1.43  | 1.40E-04 |
|    | Fe-55 | 9.17  | 8.96E-04 |
|    | Co-58 | 22.21 | 2.17E-03 |
|    | Co-60 | 11.83 | 1.16E-03 |
|    | Ni-63 | 15.82 | 1.55E-03 |

Table 32 (Continued)

Estimate of Major Nuclide Composition (by type of waste): **NRC Waste Class B**

|    | ISOTOPE | PERCENT | CURIES   |
|----|---------|---------|----------|
| a. | Mn-54   | 1.96    | 3.02E+00 |
|    | Fe-55   | 21.54   | 3.31E+01 |
|    | Co-60   | 19.23   | 2.96E+01 |
|    | Ni-63   | 53.37   | 8.21E+01 |
|    | Cs-137  | 1.24    | 1.90E+00 |
| b. | N/A     | N/A     | N/A      |
| c. | N/A     | N/A     | N/A      |
| d. | N/A     | N/A     | N/A      |
| e. | N/A     | N/A     | N/A      |

3. Solid Waste Disposition

| <u>Number of Shipments</u> | <u>Mode of Transportation</u> | <u>Destination</u>            |
|----------------------------|-------------------------------|-------------------------------|
| 4                          | Hittman Transport             | Energy Solutions – Bear Creek |
| 7                          | Hittman Transport             | Energy Solutions – Memphis    |
| 1                          | Interstate Ventures           | WCS – Compact Waste           |

B. IRRADIATED FUEL SHIPMENTS

| <u>Number of Shipments</u> | <u>Mode of Transportation</u> | <u>Destination</u> |
|----------------------------|-------------------------------|--------------------|
| N/A                        | N/A                           | N/A                |

Table 33, Solid Waste Shipped Offsite July 1, 2025 Through December 31, 2025

**A. Solid Waste Shipped Offsite For Burial Or Disposal (Not irradiated fuel)**

| 1.Type of Waste: <b><u>NRC Waste Class A</u></b>          | <u>UNIT</u>    | <u>6 month Period</u> | <u>Est. Total ERROR %</u> |
|---|----------------|-----------------------|---------------------------|
| a) Spent resins, filter sludges, evaporator bottoms, etc. | m <sup>3</sup> | 5.07E+01              | +/- 10%                   |
|   | Ci             | 2.61E+00              | +/- 10%                   |
| b) Dry compressible waste, contaminated equip., etc.      | m <sup>3</sup> | 8.52E+01              | +/- 25%                   |
|   | Ci             | 2.67E-01              | +/- 25%                   |
| c) Irradiated components, control rods, etc.              | m <sup>3</sup> | N/A                   | N/A                       |
|   | Ci             | N/A                   | N/A                       |
| d) Control Rod Drive Filters                              | m <sup>3</sup> | N/A                   | N/A                       |
|   | Ci             | N/A                   | N/A                       |
| e) Other (describe) Equipment, etc.                       | m <sup>3</sup> | 1.66E+01              | +/- 25%                   |
|   | Ci             | 2.53E-03              | +/- 25%                   |
| 1.Type of Waste: <b><u>NRC Waste Class B</u></b>          | <u>UNIT</u>    | <u>6 month Period</u> | <u>Est. Total ERROR %</u> |
| a) Spent resins, filter sludges, evaporator bottoms, etc. | m <sup>3</sup> | 4.28E+00              | +/- 10%                   |
|   | Ci             | 3.82E+01              | +/- 10%                   |
| b) Dry compressible waste, contaminated equip., etc.      | m <sup>3</sup> | N/A                   | N/A                       |
|   | Ci             | N/A                   | N/A                       |
| c) Irradiated components, control rods, etc.              | m <sup>3</sup> | N/A                   | N/A                       |
|   | Ci             | N/A                   | N/A                       |
| d) Control Rod Drive Filters                              | m <sup>3</sup> | N/A                   | N/A                       |
|   | Ci             | N/A                   | N/A                       |
| e) Other (describe)                                       | m <sup>3</sup> | N/A                   | N/A                       |
|   | Ci             | N/A                   | N/A                       |

**2. Estimate of Major Nuclide Composition (by type of waste): NRC Waste Class A**

|    | ISOTOPE | PERCENT | CURIES   |
|----|---------|---------|----------|
| a. | H-3     | 8.1     | 2.11E-01 |
|    | Mn-54   | 2.75    | 7.17E-02 |
|    | Fe-55   | 16.74   | 4.36E-01 |
|    | Co-58   | 15.51   | 4.04E-01 |
|    | Co-60   | 23.38   | 6.09E-01 |
|    | Ni-63   | 25.73   | 6.71E-01 |
|    | Zr-95   | 1.49    | 3.90E-02 |
|    | Nb-95   | 3.2     | 8.35E-02 |
|    | Sb-125  | 1.54    | 4.01E-02 |
| b. | H-3     | 19.89   | 5.31E-03 |
|    | C-14    | 1.47    | 3.92E-04 |
|    | Mn-54   | 2.11    | 5.63E-04 |
|    | Fe-55   | 12.68   | 3.38E-03 |

Company: Southern Nuclear Company

Plant: Vogtle Electric Generating Plant 1&amp;2

|    |        |       |          |
|----|--------|-------|----------|
|    | Co-58  | 20.87 | 5.56E-03 |
|    | Co-60  | 17.14 | 4.57E-03 |
|    | Ni-63  | 20.03 | 5.34E-03 |
|    | Zr-95  | 1.15  | 3.06E-04 |
|    | Nb-95  | 2.4   | 6.40E-04 |
| c. | N/A    | N/A   | N/A      |
| d. | N/A    | N/A   | N/A      |
| e. | H-3    | 7.55  | 1.91E-04 |
|    | Mn-54  | 2.72  | 6.88E-05 |
|    | Fe-55  | 15.84 | 4.01E-04 |
|    | Co-58  | 19.1  | 4.83E-04 |
|    | Co-60  | 21.91 | 5.54E-04 |
|    | Ni-63  | 23.88 | 6.04E-04 |
|    | Zr-95  | 1.9   | 4.80E-05 |
|    | Nb-95  | 4.03  | 1.02E-04 |
|    | Sb-125 | 1.45  | 3.68E-05 |

Estimate of Major Nuclide Composition (by type of waste): **NRC Waste Class B**

|    | ISOTOPE | PERCENT | CURIES   |
|----|---------|---------|----------|
| a. | H-3     | 1.83    | 7.00E-01 |
|    | Mn-54   | 2.43    | 9.29E-01 |
|    | Fe-55   | 15.33   | 5.85E+00 |
|    | Co-58   | 5.35    | 2.04E+00 |
|    | Co-60   | 25.62   | 9.78E+00 |
|    | Ni-63   | 44.75   | 1.71E+01 |
|    | Cs-137  | 1.13    | 4.30E-01 |
| b. | N/A     | N/A     | N/A      |
| c. | N/A     | N/A     | N/A      |
| d. | N/A     | N/A     | N/A      |
| e. | N/A     | N/A     | N/A      |

## 3. Solid Waste Disposition

Number of ShipmentsMode of TransportationDestination

3

Hittman Transport

Energy Solutions – Bear Creek

5

Hittman Transport

Energy Solutions – Memphis

2

Hittman Transport

Energy Solutions – Erwin

1

Interstate Ventures

WCS – Compact Waste

**B. IRRADIATED FUEL SHIPMENTS**

| <u>Number of Shipments</u> | <u>Mode of Transportation</u> | <u>Destination</u> |
|----------------------------|-------------------------------|--------------------|
| N/A                        | N/A                           | N/A                |

**Attachment 3, NEI 07-07 Onsite Radiological Groundwater Monitoring Program**

To ensure compliance with NEI 07-07 (Industry Ground Water Protection Initiative – Final Guidance Document), Southern Nuclear implemented a groundwater protection program which is proceduralized in Nuclear Management Procedure, Radiological Groundwater Protection Program. The procedure contains detailed site-specific monitoring plans, program technical bases, and communications protocol (to ensure that radioactive leaks and spills are addressed and communicated appropriately). In an effort to prevent future leaks of radioactive material to groundwater, SNC plants have established buried piping and tanks inspection programs. No changes were made to the Groundwater Protection Program in 2025.

Vogtle Electric Generating Plant Units 1&2 groundwater protection program consists of 19 sample points listed in Table 34. The points are sampled at a frequency that satisfies the requirements of NEI 07-07. Table 35 contains the 2025 analytical results of the VEGP 1&2 groundwater protection program tritium results (in pCi/L). Figure 5 is a map of the monitoring network.

Table 34 – Groundwater Protection Program Sample Points

| <b>Sample Point</b> | <b>Aquifer</b>    | <b>Monitoring Purpose</b>                    |
|---------------------|-------------------|--|
| LT-1B               | Surficial Aquifer | NSCW related tank                            |
| LT-7A               | Surficial Aquifer | NSCW related tank                            |
| LT-12               | Surficial Aquifer | NSCW related tank                            |
| LT-13               | Surficial Aquifer | NSCW related tank                            |
| 802A                | Surficial Aquifer | Southeastern potential leakage               |
| 806B                | Surficial Aquifer | Dilution line                                |
| 808                 | Surficial Aquifer | Up gradient (Pen Branch Fault)               |
| R-1                 | Surficial Aquifer | NSCW related tank; western potential leakage |
| R-2                 | Surficial Aquifer | Southern potential leakage                   |

**Company: Southern Nuclear Company****Plant: Vogtle Electric Generating Plant 1&2**

|       |                     |                           |
|-------|---------------------|---------------------------|
| R-3   | Surficial Aquifer   | Eastern potential leakage |
| R-4   | Surficial Aquifer   | Dilution line             |
| R-5   | Surficial Aquifer   | Dilution line             |
| R-6   | Surficial Aquifer   | Dilution line             |
| R-7   | Surficial Aquifer   | Dilution line             |
| R-8   | Alluvial Aquifer    | Dilution line             |
| 1014  | Tertiary            | Up gradient               |
| 1015  | Surficial Aquifer   | Vertically up gradient    |
| MU-1  | Tertiary/Cretaceous | Facility water supply     |
| River | N/A                 | Surface water             |

**Company: Southern Nuclear Company****Plant: Vogtle Electric Generating Plant 1&2**

Table 35 – Groundwater Protection Program 2025 Sample Results

| Table 35, Groundwater Protection Program 2025 Sample Results                                |                               |                    |                               |                               |
|---|-------------------------------|--------------------|-------------------------------|-------------------------------|
| Name  | Number of Positive Detections | Number of Analyses | Average Concentration (pCi/L) | Maximum Concentration (pCi/L) |
| 1014  | 0                             | 2                  | NDM                           | NDM                           |
| 1015  | 0                             | 2                  | NDM                           | NDM                           |
| 806B  | 2                             | 2                  | 353                           | 353                           |
| 808   | 1                             | 2                  | 298                           | 298                           |
| LT-12   | 4                             | 4                  | 2238                          | 2960                          |
| LT-13   | 3                             | 4                  | 224                           | 375                           |
| LT-1B   | 4                             | 4                  | 278                           | 341                           |
| LT-7A   | 1                             | 4                  | 450                           | 450                           |
| R-1   | 2                             | 2                  | 162                           | 164                           |
| R-2   | 1                             | 2                  | 120                           | 120                           |
| R-3   | 2                             | 2                  | 127                           | 154                           |
| R-4   | 0                             | 2                  | NDM                           | NDM                           |
| R-5   | 2                             | 2                  | 175                           | 192                           |
| R-6   | 2                             | 2                  | 174                           | 247                           |
| R-7   | 0                             | 2                  | NDM                           | NDM                           |
| R-8   | 0                             | 2                  | NDM                           | NDM                           |
| River sample  | 1                             | 2                  | 167                           | 167                           |
| <b>Notes:</b> <b>NDM:</b> No Detectable Measurement - Less than Minimal Detectable Activity |                               |                    |                               |                               |

Figure 5 – Vogtle Electric Generating Plant Units 1&2 GWPP Monitoring Network

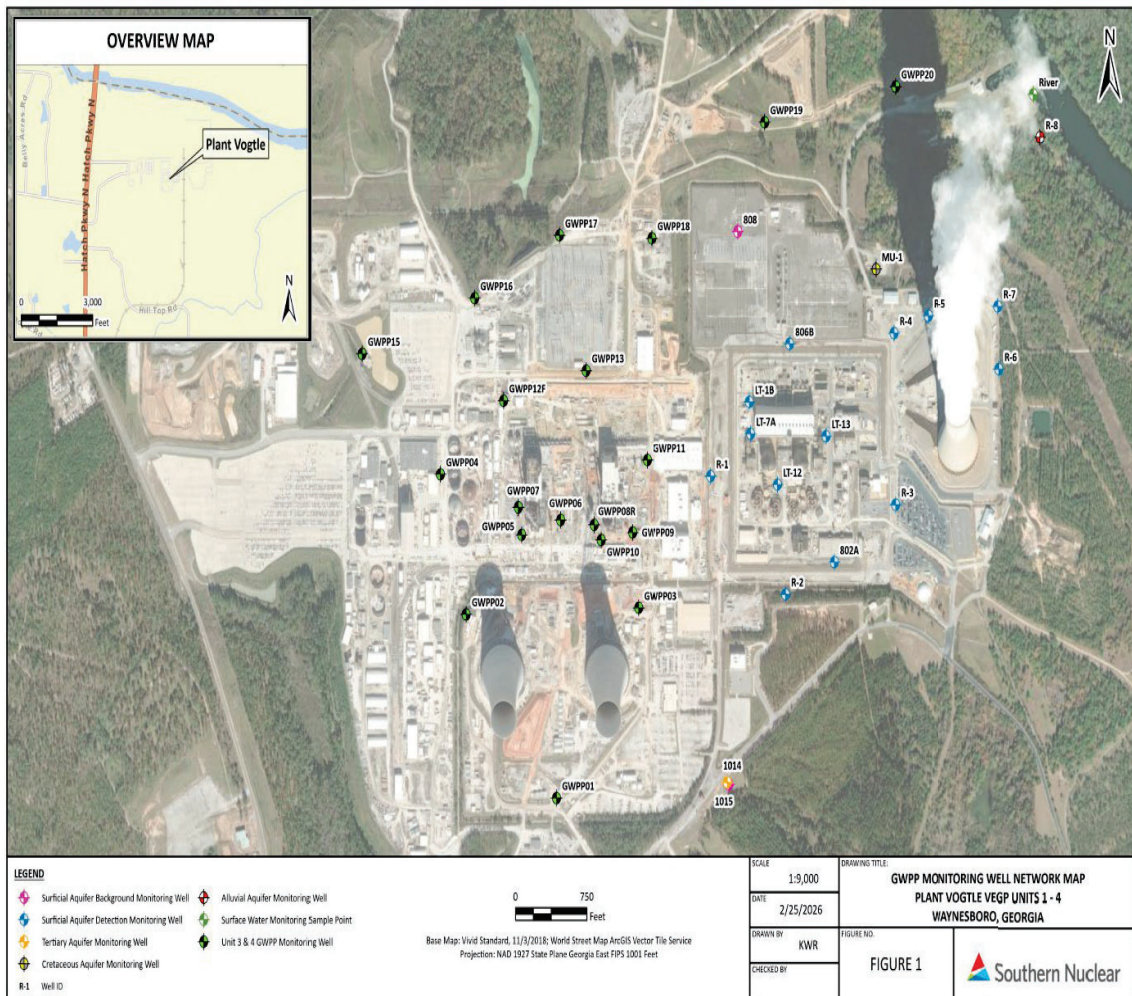

**Vogtle Electric Generating Plant – Units 1 and 2**  
**Annual Radioactive Effluent Release Report and**  
**Annual Non-Radiological Environmental Operating Report for 2025**

**Enclosure 2 to NL-26-0155**

**VEGP Units 1 and 2 Offsite Dose Calculation Manual - Version 38**

OFFSITE DOSE CALCULATION MANUAL  
FOR  
SOUTHERN NUCLEAR OPERATING COMPANY  
VOGTLE ELECTRIC GENERATING PLANT UNITS 1 AND 2

Version 38

March 2025

| <u>TABLE OF CONTENTS</u>  |  | <u>PAGE</u> |
|---|--|-------------|
| TABLE OF CONTENTS .....   |  | i           |
| LIST OF TABLES.....   |  | iv          |
| LIST OF FIGURES .....   |  | vi          |
| REFERENCES .....  |  | vii         |
| CHAPTER 1: INTRODUCTION .....   |  | 1-1         |
| CHAPTER 2: LIQUID EFFLUENTS .....   |  | 2-1         |
| 2.1 LIMITS OF OPERATION   |  | 2-1         |
| 2.1.1 <u>Liquid Effluent Monitoring Instrumentation Control</u>           |  | 2-1         |
| 2.1.2 <u>Liquid Effluent Concentration Control</u>                        |  | 2-7         |
| 2.1.3 <u>Liquid Effluent Dose Control</u>                                 |  | 2-10        |
| 2.1.4 <u>Liquid Radwaste Treatment System Control</u>                     |  | 2-11        |
| 2.1.5 <u>Major Changes to Liquid Radioactive Waste Treatment Systems</u>  |  | 2-12        |
| 2.2 LIQUID RADWASTE TREATMENT SYSTEM                                      |  | 2-13        |
| 2.3 LIQUID EFFLUENT MONITOR SETPOINTS                                     |  | 2-17        |
| 2.3.1 <u>General Provisions Regarding Setpoints</u>                       |  | 2-17        |
| 2.3.2 <u>Setpoints for Radwaste System Discharge Monitors</u>             |  | 2-19        |
| 2.3.3 <u>Setpoints for Monitors on Normally Low-Radioactivity Streams</u> |  | 2-25        |
| 2.4 LIQUID EFFLUENT DOSE CALCULATIONS                                     |  | 2-26        |
| 2.4.1 <u>Calculation of Dose</u>  |  | 2-26        |
| 2.4.2 <u>Calculation of <math>A_{ir}</math></u>                           |  | 2-27        |
| 2.4.3 <u>Calculation of <math>CF_{iv}</math></u>                          |  | 2-28        |
| 2.5 LIQUID EFFLUENT DOSE PROJECTIONS                                      |  | 2-37        |
| 2.5.1 <u>Thirty-One Day Dose Projections</u>                              |  | 2-37        |
| 2.5.2 <u>Dose Projections for Specific Releases</u>                       |  | 2-37        |
| 2.6 DEFINITIONS OF LIQUID EFFLUENT TERMS                                  |  | 2-38        |
| CHAPTER 3: GASEOUS EFFLUENTS .....  |  | 3-1         |
| 3.1 LIMITS OF OPERATION   |  | 3-1         |
| 3.1.1 <u>Gaseous Effluent Monitoring Instrumentation Control</u>          |  | 3-1         |
| 3.1.2 <u>Gaseous Effluent Dose Rate Control</u>                           |  | 3-7         |
| 3.1.3 <u>Gaseous Effluent Air Dose Control</u>                            |  | 3-10        |
| 3.1.4 <u>Control on Gaseous Effluent Dose to a Member of the Public</u>   |  | 3-11        |
| 3.1.5 <u>Gaseous Radwaste Treatment System Control</u>                    |  | 3-12        |
| 3.1.6 <u>Major Changes to Gaseous Radioactive Waste Treatment Systems</u> |  | 3-13        |

TABLE OF CONTENTS (continued)

|  | <u>PAGE</u> |
|--|-------------|
| 3.2 GASEOUS WASTE PROCESSING SYSTEM  | 3-14        |
| 3.3 GASEOUS EFFLUENT MONITOR SETPOINTS   | 3-20        |
| 3.3.1 <u>General Provisions Regarding Noble Gas Monitor Setpoints</u>  | 3-20        |
| 3.3.2 <u>Setpoint for the Final Noble Gas Monitor on Each Release Pathway</u>                                | 3-22        |
| 3.3.3 <u>Setpoints for Noble Gas Monitors on Effluent Source Streams</u>                                     | 3-25        |
| 3.3.4 <u>Determination of Allocation Factors, AG</u>   | 3-27        |
| 3.3.5 <u>Setpoints for Noble Gas Monitors with Special Requirements</u>                                      | 3-29        |
| 3.3.6 <u>Setpoints for Particulate and Iodine Monitors</u>   | 3-29        |
| 3.4 GASEOUS EFFLUENT COMPLIANCE CALCULATIONS   | 3-30        |
| 3.4.1 <u>Dose Rates at and Beyond the Site Boundary</u>  | 3-30        |
| 3.4.2 <u>Noble Gas Air Dose at or Beyond Site Boundary</u>   | 3-31        |
| 3.4.3 <u>Dose to a Member of the Public at or Beyond Site Boundary</u>                                       | 3-35        |
| 3.4.4 <u>Dose Calculations to Support Other Requirements</u>   | 3-38        |
| 3.5 GASEOUS EFFLUENT DOSE PROJECTIONS  | 3-44        |
| 3.5.1 <u>Thirty-One Day Dose Projections</u>   | 3-44        |
| 3.5.2 <u>Dose Projections for Specific Releases</u>  | 3-45        |
| 3.6 DEFINITIONS OF GASEOUS EFFLUENT TERMS  | 3-46        |
| CHAPTER 4: RADIOLOGICAL ENVIRONMENTAL MONITORING PROGRAM.....  | 4-1         |
| 4.1 LIMITS OF OPERATION  | 4-1         |
| 4.1.1 <u>Radiological Environmental Monitoring</u>   | 4-1         |
| 4.1.2 <u>Land Use Census</u>   | 4-9         |
| 4.1.3 <u>Interlaboratory Comparison Program</u>  | 4-10        |
| 4.2 RADIOLOGICAL ENVIRONMENTAL MONITORING LOCATIONS  | 4-11        |
| CHAPTER 5: TOTAL DOSE DETERMINATIONS.....  | 5-1         |
| 5.1 LIMIT OF OPERATION   | 5-1         |
| 5.1.1 <u>Applicability</u>   | 5-1         |
| 5.1.2 <u>Actions</u>   | 5-1         |
| 5.1.3 <u>Surveillance Requirements</u>   | 5-1         |
| 5.1.4 <u>Basis</u>   | 5-1         |
| 5.2 DEMONSTRATION OF COMPLIANCE  | 5-3         |
| CHAPTER 6: POTENTIAL DOSES TO MEMBERS OF THE PUBLIC DUE TO THEIR<br>ACTIVITIES INSIDE THE SITE BOUNDARY..... | 6-1         |
| 6.1 REQUIREMENT FOR CALCULATION  | 6-1         |
| 6.2 CALCULATIONAL METHOD   | 6-1         |

TABLE OF CONTENTS (continued)

|   | <u>PAGE</u> |
|---|-------------|
| CHAPTER 7: REPORTS .....  | 7-1         |
| 7.1 ANNUAL RADIOLOGICAL ENVIRONMENTAL SURVEILLANCE REPORT   | 7-1         |
| 7.1.1 <u>Requirement for Report</u>   | 7-1         |
| 7.1.2 <u>Report Contents</u>  | 7-1         |
| 7.2 RADIOACTIVE EFFLUENT RELEASE REPORT   | 7-3         |
| 7.2.1 <u>Requirement for Report</u>   | 7-3         |
| 7.2.2 <u>Report Contents</u>  | 7-3         |
| 7.3 MONTHLY OPERATING REPORT  | 7-6         |
| 7.4 SPECIAL REPORTS   | 7-6         |
| CHAPTER 8: METEOROLOGICAL MODELS .....  | 8-1         |
| 8.1 ATMOSPHERIC DISPERSION  | 8-1         |
| 8.1.1 <u>Ground-Level Releases</u>  | 8-1         |
| 8.1.2 <u>Elevated Releases</u>  | 8-2         |
| 8.1.3 <u>Mixed-Mode Releases</u>  | 8-4         |
| 8.2 RELATIVE DEPOSITION   | 8-5         |
| 8.2.1 <u>Ground-Level Releases</u>  | 8-5         |
| 8.2.2 <u>Elevated Releases</u>  | 8-5         |
| 8.2.3 <u>Mixed-Mode Releases</u>  | 8-6         |
| 8.3 ELEVATED PLUME DOSE FACTORS   | 8-6         |
| CHAPTER 9: METHODS AND PARAMETERS FOR CALCULATION OF GASEOUS<br>EFFLUENT PATHWAY DOSE FACTORS, $R_{aipj}$ ..... | 9-1         |
| 9.1 INHALATION PATHWAY FACTOR   | 9-1         |
| 9.2 GROUND PLANE PATHWAY FACTOR   | 9-2         |
| 9.3 GARDEN VEGETATION PATHWAY FACTOR  | 9-3         |
| 9.4 GRASS-COW-MILK PATHWAY FACTOR   | 9-6         |
| 9.5 GRASS-GOAT-MILK PATHWAY FACTOR  | 9-9         |
| 9.6 GRASS-COW-MEAT PATHWAY FACTOR   | 9-12        |
| CHAPTER 10: DEFINITIONS OF EFFLUENT CONTROL TERMS.....  | 10-1        |
| 10.1 TERMS SPECIFIC TO THE ODCM   | 10-1        |
| 10.2 TERMS DEFINED IN THE TECHNICAL SPECIFICATIONS  | 10-5        |

LIST OF TABLES

|   | <u>PAGE</u> |
|---|-------------|
| Table 2-1. Radioactive Liquid Effluent Monitoring Instrumentation                                     | 2-3         |
| Table 2-2. Radioactive Liquid Effluent Monitoring Instrumentation Surveillance Requirements           | 2-5         |
| Table 2-3. Radioactive Liquid Waste Sampling and Analysis Program                                     | 2-8         |
| Table 2-4. Applicability of Liquid Monitor Setpoint Methodologies                                     | 2-18        |
| Table 2-5. Parameters for Calculation of Doses Due to Liquid Effluent Releases                        | 2-30        |
| Table 2-6. Element Transfer Factors   | 2-31        |
| Table 2-7. Adult Ingestion Dose Factors   | 2-32        |
| Table 2-8. Site-Related Ingestion Dose Factors, $A_{ir}$  | 2-35        |
| Table 3-1. Radioactive Gaseous Effluent Monitoring Instrumentation                                    | 3-3         |
| Table 3-2. Radioactive Gaseous Effluent Monitoring Instrumentation Surveillance Requirements          | 3-5         |
| Table 3-3. Radioactive Gaseous Waste Sampling and Analysis Program                                    | 3-8         |
| Table 3-4. Applicability of Gaseous Monitor Setpoint Methodologies                                    | 3-21        |
| Table 3-5. Dose Factors for Exposure to a Semi-Infinite Cloud of Noble Gases                          | 3-33        |
| Table 3-6. Dose Factors for Exposure to Direct Radiation from Noble Gases in an Elevated Finite Plume | 3-34        |
| Table 3-7. Attributes of the Controlling Receptor   | 3-37        |
| Table 3-8. $R_{aipj}$ for Ground Plane Pathway, All Age Groups  | 3-39        |
| Table 3-9. $R_{aipj}$ for Inhalation Pathway, Child Age Group   | 3-40        |
| Table 3-10. $R_{aipj}$ for Inhalation Pathway, Adult Age Group  | 3-41        |
| Table 3-11. $R_{aipj}$ for Cow Meat Pathway, Child Age Group  | 3-42        |
| Table 3-12. $R_{aipj}$ for Garden Vegetation, Child Age Group   | 3-43        |
| Table 4-1. Radiological Environmental Monitoring Program  | 4-3         |

LIST OF TABLES (Continued)

|             |  | <u>PAGE</u> |
|-------------|--|-------------|
| Table 4-2.  | Reporting Levels for Radioactivity Concentrations in Environmental Samples     | 4-7         |
| Table 4-3.  | Values for the Minimum Detectable Concentration (MDC)                          | 4-8         |
| Table 4-4.  | Radiological Environmental Monitoring Locations                                | 4-12        |
| Table 6-1.  | Attributes of Member of the Public Receptor Locations Inside the Site Boundary | 6-2         |
| Table 8-1.  | Terrain Elevation Above Plant Site Grade                                       | 8-8         |
| Table 9-1.  | Miscellaneous Parameters for the Garden Vegetation Pathway                     | 9-5         |
| Table 9-2.  | Miscellaneous Parameters for the Grass-Cow-Milk Pathway                        | 9-8         |
| Table 9-3.  | Miscellaneous Parameters for the Grass-Goat-Milk Pathway                       | 9-11        |
| Table 9-4.  | Miscellaneous Parameters for the Grass-Cow-Meat Pathway                        | 9-14        |
| Table 9-5.  | Individual Usage Factors   | 9-15        |
| Table 9-6.  | Stable Element Transfer Data   | 9-16        |
| Table 9-7.  | Inhalation Dose Factors for the Infant Age Group                               | 9-17        |
| Table 9-8.  | Inhalation Dose Factors for the Child Age Group                                | 9-20        |
| Table 9-9.  | Inhalation Dose Factors for the Teenager Age Group                             | 9-23        |
| Table 9-10. | Inhalation Dose Factors for the Adult Age Group                                | 9-26        |
| Table 9-11. | Ingestion Dose Factors for the Infant Age Group                                | 9-29        |
| Table 9-12. | Ingestion Dose Factors for the Child Age Group                                 | 9-32        |
| Table 9-13. | Ingestion Dose Factors for the Teenager Age Group                              | 9-35        |
| Table 9-14. | Ingestion Dose Factors for the Adult Age Group                                 | 9-38        |
| Table 9-15. | External Dose Factors for Standing on Contaminated Ground                      | 9-41        |

LIST OF FIGURES

|   | <u>PAGE</u> |
|---|-------------|
| Figure 2-1. Unit 1 Liquid Radwaste Treatment System   | 2-14        |
| Figure 2-2. Unit 2 Liquid Radwaste Treatment System   | 2-15        |
| Figure 2-3. Liquid Radwaste Discharge Pathways  | 2-16        |
| Figure 3-1. Schematic Diagram of the Gaseous Radwaste Treatment System                                | 3-15        |
| Figure 3-2. Schematic Diagram of the Unit 1 Plant Vent Release Pathway                                | 3-16        |
| Figure 3-3. Schematic Diagram of the Unit 2 Plant Vent Release Pathway                                | 3-17        |
| Figure 3-4. Schematic Diagram of the Turbine Building Vent Release Pathway<br>(Typical of Both Units) | 3-18        |
| Figure 3-5. Schematic Diagram of the Radwaste Processing Facility Ventilation<br>Release Pathway      | 3-19        |
| Figure 4-1. Sampling Location Map (Onsite)  | 4-18        |
| Figure 4-2. Sampling Location Map (Near Field/Site Boundary)  | 4-19        |
| Figure 4-3. Sampling Location Map (Far Field)   | 4-20        |
| Figure 8-1. Vertical Standard Deviation of Material in a Plume ( $\sigma_z$ )                         | 8-7         |
| Figure 8-2. Terrain Recirculation Factor ( $K_r$ )  | 8-9         |
| Figure 8-3. Plume Depletion Effect for Ground Level Releases  | 8-10        |
| Figure 8-4. Plume Depletion Effect for 30-Meter Releases  | 8-11        |
| Figure 8-5. Plume Depletion Effect for 60-Meter Releases  | 8-12        |
| Figure 8-6. Plume Depletion Effect for 100-Meter Releases   | 8-13        |
| Figure 8-7. Relative Deposition for Ground-Level Releases   | 8-14        |
| Figure 8-8. Relative Deposition for 30-Meter Releases   | 8-15        |
| Figure 8-9. Relative Deposition for 60-Meter Releases   | 8-16        |
| Figure 8-10. Relative Deposition for 100-Meter (or Greater) Releases                                  | 8-17        |

---

REFERENCES

1. J.S. Boegli, R.R. Bellamy, W.L. Britz, and R.L. Waterfield, "Preparation of Radiological Effluent Technical Specifications for Nuclear Power Plants," NUREG-0133, October 1978.
2. "Calculation of Annual Doses to Man from Routine Releases of Reactor Effluents for the Purpose of Evaluating Compliance with 10 CFR 50, Appendix I," U.S. NRC Regulatory Guide 1.109, March 1976.
3. "Calculation of Annual Doses to Man from Routine Releases of Reactor Effluents for the Purpose of Evaluating Compliance with 10 CFR 50, Appendix I," U.S. NRC Regulatory Guide 1.109, Revision 1, October 1977.
4. "Methods for Estimating Atmospheric Transport and Dispersion of Gaseous Effluents in Routine Releases from Light-Water-Cooled Reactors," U.S. NRC Regulatory Guide 1.111, March 1976.
5. "Methods for Estimating Atmospheric Transport and Dispersion of Gaseous Effluents in Routine Releases from Light-Water-Cooled Reactors," U.S. NRC Regulatory Guide 1.111, Revision 1, July 1977.
6. "Estimating Aquatic Dispersion of Effluents from Accidental and Routine Reactor Releases for the Purpose of Implementing Appendix I," U.S. NRC Regulatory Guide 1.113, April 1977.
7. W.R. Stokes III, T.W. Hale, J.L. Pearman, and G.R. Buell, "Water Resources Data, Georgia, Water Year 1983," U.S. Geological Survey Water Data Report GA-83-1, June 1984.
8. Direct communication with the Water Resources Division, U.S. Geological Survey, U.S. Department of the Interior, February 1985.
9. Bernd Kahn, *et al.*, "Bioaccumulation of P-32 in Bluegill and Catfish," NUREG/CR-3981, February 1985.
10. Memo from S.E. Ewald, Georgia Power Company, to C.C. Eckert, Georgia Power Company, May 9, 1988.
11. Vogtle Electric Generating Plant Units 1 and 2 Final Safety Analysis Report, Georgia Power Company.
12. Vogtle Electric Generating Plant Units 1 and 2 Environmental Report - Operating License Stage, Georgia Power Company.
13. Memo from A.C. Stalker, Georgia Power Company, to D.F. Hallman, Georgia Power Company, May 9, 1988.
14. Vogtle Electric Generating Plant Land Use Survey - 1988, Georgia Power Company, April 1988.

15. Letter to Southern Company Services from Pickard, Lowe, and Garrick, Inc., Washington, D.C., April 27, 1988.
16. Letter to Bill Ollinger, Georgia Power Company, from T.L. Broadwell, Georgia Power Company, Atlanta, Georgia, June 22, 1988.
17. Letter to Bill Ollinger, Georgia Power Company, from R.D. Just, Georgia Power Company, Atlanta, Georgia, July 8, 1988.
18. L.A. Currie, Lower Limit of Detection: Definition and Elaboration of a Proposed Position of Radiological Effluent and Environmental Measurements, U.S. NRC Report NUREG/CR-4007, 1984.
19. "Radiological Assessment Branch Technical Position," U.S. Nuclear Regulatory Commission, Revision 1, November 1979.
20. D.C. Kocher, "Radioactive Decay Data Tables," U.S. DOE Report DOE/TIC-11026, 1981.
21. J.E. Till and H.R. Meyer, eds., Radiological Assessment, U.S. NRC Report NUREG/CR-3332, 1983.
22. Letter to Bill Ollinger, Southern Nuclear Operating Company, from Gary D. Johnson, Georgia Power Company, December 21, 1995.
23. Letter to Mary Beth Lloyd, Southern Nuclear Operating Company, from Steven Bearce, Southern Company Services, February 2, 2009.
24. EV-13-1797, EACRS Intracompany Correspondence, "Vogtle REMP Drinking Water Sampling Stations"
25. EV-14-0226, EACRS Intracompany Correspondence, "Vogtle 1 and 2 Tritium Monitoring Well Update"

---

## CHAPTER 1

### INTRODUCTION

The Offsite Dose Calculation Manual is a supporting document of the Technical Specifications. As such, it describes the methodology and parameters to be used in the calculation of offsite doses due to radioactive liquid and gaseous effluents, and in the calculation of liquid and gaseous effluent monitoring instrumentation alarm setpoints. In addition, it contains the following:

- The controls required by the Technical Specifications, governing the radioactive effluent and radiological environmental monitoring programs.
- Schematics of liquid and gaseous radwaste effluent treatment systems, which include designation of release points to UNRESTRICTED AREAS.
- A list and maps indicating the specific sample locations for the Radiological Environmental Monitoring Program.
- Specifications and descriptions of the information that must be included in the Annual Radiological Environmental Operating Report and the Radioactive Effluent Release Report required by the Technical Specifications.

The ODCM will be maintained at the plant for use as a reference guide and training document of accepted methodologies and calculations. Changes in the calculational methods or parameters will be incorporated into the ODCM in order to ensure that it represents current methodology in all applicable areas. Any computer software used to perform the calculations described will be maintained current with the ODCM.

Equations and methods used in the ODCM are based on those presented in NUREG-0133 (Reference 1), in Regulatory Guide 1.109 (References 2 and 3), in Regulatory Guide 1.111 (References 4 and 5), and in Regulatory Guide 1.113 (Reference 6).

---

## CHAPTER 2

### LIQUID EFFLUENTS

#### 2.1 LIMITS OF OPERATION

The following Liquid Effluent Controls implement requirements established by Technical Specifications Section 5.0. Terms printed in all capital letters are defined in Chapter 10.

##### 2.1.1 Liquid Effluent Monitoring Instrumentation Control

In accordance with Technical Specification 5.5.4.a, the radioactive liquid effluent monitoring instrumentation channels shown in Table 2-1 shall be FUNCTIONAL with their alarm/trip setpoints set to ensure that the limits specified in Section 2.1.2 are not exceeded. The alarm/trip setpoints of these channels shall be determined in accordance with Section 2.3.

###### 2.1.1.1 Applicability

This limit applies at all times.

###### 2.1.1.2 Actions

With a radioactive liquid effluent monitoring instrumentation channel alarm/trip setpoint less conservative than required by the above control, immediately suspend the release of radioactive liquid effluents monitored by the affected channel, declare the channel NON-FUNCTIONAL, or change the setpoint to a conservative value.

With less than the minimum number of radioactive liquid effluent monitoring instrumentation channels FUNCTIONAL, take the ACTION shown in Table 2-1. Restore the NON-FUNCTIONAL instrumentation to FUNCTIONAL status within 30 days, or if unsuccessful, explain in the next Radioactive Effluent Release Report, per Technical Specification 5.6.3, why this NON-FUNCTIONALITY was not corrected in a timely manner.

This control does not affect shutdown requirements or MODE changes.

###### 2.1.1.3 Surveillance Requirements

Each radioactive liquid effluent monitoring instrumentation channel shall be demonstrated FUNCTIONAL by performance of the CHANNEL CHECK, SOURCE CHECK, CHANNEL CALIBRATION, and CHANNEL FUNCTIONALITY TEST operations at the frequencies shown in Table 2-2. Specific instrument numbers are provided in parentheses for information only. The numbers apply to each unit. These numbers will help to identify associated channels or loops and are not intended to limit the requirements to the specific instruments associated with the number.

#### 2.1.1.4 Basis

The radioactive liquid effluent instrumentation is provided to monitor and control, as applicable, the releases of radioactive materials in liquid effluents during actual or potential releases of liquid effluents. The Alarm/Trip Setpoints for these instruments shall be calculated and adjusted in accordance with the methodology and parameters in Section 2.3 to ensure that the alarm/trip will occur prior to exceeding the limits of Section 2.1.2. The FUNCTIONALITY and use of this instrumentation is consistent with the requirements of General Design Criteria 60, 63, and 64 of Appendix A to 10 CFR Part 50.

Table 2-1. Radioactive Liquid Effluent Monitoring Instrumentation

| Instrument   | FUNCTIONALITY Requirements <sup>a</sup> |        |
|--|---|--------|
|  | Minimum Channels FUNCTIONAL             | ACTION |
| 1. Radwaste Monitors Providing Alarm and Automatic Termination of Release      |   |        |
| a. Liquid Radwaste Effluent Line (RE-0018)                                     | 1                                       | 37     |
| b. Steam Generator Blowdown Effluent Line (RE-0021)                            | 1                                       | 38     |
| c. Turbine Building Effluent Line (RE-0848)                                    | 1                                       | 38     |
| 2. Radwaste Monitors Providing Alarm, but Not Automatic Termination of Release |   |        |
| NSCW Effluent Line (RE-0020 A)   | 1                                       | 39     |
| NSCW Effluent Line (RE-0020 B)   | 1                                       | 39     |
| 3. Flowrate Measurement Devices  |   |        |
| a. Liquid Radwaste Effluent Line (FT-0018), (FT-1084A/B), or (FT-1085A/B)      | 1                                       | 40     |
| b. Steam Generator Blowdown Effluent Line (FT-0021)                            | 1                                       | 40     |
| c. Flow to Blowdown Sump (AFQI-7620, FI7620A)                                  | 1                                       | 40     |

a. All requirements in this table apply to each unit.

---

Table 2-1 (contd).                      Notation for Table 2-1 — ACTION Statements

---

**ACTION 37** — With the number of channels FUNCTIONAL less than required by the Minimum Channels FUNCTIONAL requirement, effluent releases may continue provided that prior to initiating a release:

- a.        The local radiation monitor reading (if functional) is recorded at least once per 12 hours during the release or at least two independent samples are analyzed in accordance with Section 2.1.2.3, and
- b.        At least two technically qualified members of the Facility Staff independently verify the discharge line valving and the release rate calculations.

Otherwise, suspend release of radioactive effluents via this pathway.

**ACTION 38** — With the number of channels FUNCTIONAL less than required by the Minimum Channels FUNCTIONAL requirement, effluent releases via this pathway may continue provided the local radiation monitor reading (if functional) is recorded at least once per 12 hours or grab samples are analyzed for gross radioactivity at a MINIMUM DETECTABLE CONCENTRATION no higher than  $1 \times 10^{-7}$   $\mu\text{Ci}/\text{mL}$  using gross beta/gamma counting or  $5 \times 10^{-7}$   $\mu\text{Ci}/\text{mL}$  for the principal gamma emitters using gamma-ray spectroscopy.

- a.        At least once per 12 hours when the specific activity of the secondary coolant is greater than 0.01  $\mu\text{Ci}/\text{gram}$  DOSE EQUIVALENT I-131.
- b.        At least once per 24 hours when the specific activity of the secondary coolant is less than or equal to 0.01  $\mu\text{Ci}/\text{gram}$  DOSE EQUIVALENT I-131.

**ACTION 39** — With the number of channels FUNCTIONAL less than required by the Minimum Channels FUNCTIONAL requirement, effluent releases via this pathway may continue provided that, at least once per 12 hours, the local radiation monitor reading (if functional) is recorded or grab samples are collected and analyzed for radioactivity at a MINIMUM DETECTABLE CONCENTRATION no higher than  $1 \times 10^{-7}$   $\mu\text{Ci}/\text{mL}$  using gross beta/gamma counting or  $5 \times 10^{-7}$   $\mu\text{Ci}/\text{mL}$  for the principal gamma emitters using gamma-ray spectroscopy.

**ACTION 40** — With the number of channels FUNCTIONAL less than required by the Minimum Channels FUNCTIONAL requirement, effluent releases via this pathway may continue provided the flowrate is estimated at least once per 4 hours during actual releases. Pump curves generated in place may be used to estimate flow.

Table 2-2. Radioactive Liquid Effluent Monitoring Instrumentation Surveillance Requirements

| Instrument  | Surveillance Requirements <sup>d</sup> |              |                     |                         |
|---|--|--------------|---------------------|-------------------------|
|   | CHANNEL CHECK                          | SOURCE CHECK | CHANNEL CALIBRATION | CHANNEL FUNCTIONAL TEST |
| <b>1. Radwaste Monitors Providing Alarm and Automatic Termination of Release</b>      |  |              |                     |                         |
| a. Liquid Radwaste Effluent Line (RE-0018)  | P                                      | P            | R <sup>b</sup>      | R <sup>a(1)</sup>       |
| b. Steam Generator Blowdown Effluent Line (RE-0021)                                   | M                                      | SA           | R <sup>b</sup>      | R <sup>a(1)</sup>       |
| c. Turbine Building Effluent Line (RE-0848)   | M                                      | SA           | R <sup>b</sup>      | R <sup>a(1)</sup>       |
| <b>2. Radwaste Monitors Providing Alarm, but Not Automatic Termination of Release</b> |  |              |                     |                         |
| NSCW Effluent Line (RE-0020 A&B)  | M                                      | SA           | R <sup>b</sup>      | R <sup>a(2)</sup>       |
| <b>3. Flowrate Measurement Devices</b>  |  |              |                     |                         |
| a. Liquid Radwaste Effluent Line (FT-0018)  | P <sup>c</sup>                         | NA           | R                   | NA                      |
| b. Liquid Radwaste Effluent Line (FT-1084A/B), or (FT-1085A/B)                        | M <sup>c</sup>                         | NA           | R                   | NA                      |
| b. Steam Generator Blowdown Effluent Line (FT-0021)                                   | M <sup>c</sup>                         | NA           | R                   | NA                      |
| d. Flow to Blowdown Sump (AFQI-7620, FI7620A)   | M <sup>c</sup>                         | NA           | R                   | Q                       |

Table 2-2 (contd). Notation for Table 2-2

- 
- a. In addition to the basic functions of a CHANNEL FUNCTIONAL TEST (Section 10.2):
- (1) The CHANNEL FUNCTIONAL TEST shall also demonstrate that automatic isolation of this pathway and control room annunciation occurs (for item a. below only); and control room CRT indication occurs (if any of the following conditions exist):
    - (a) Instrument indicates measured levels above the alarm/trip setpoint;
    - (b) Instrument indicates an "Equipment Trouble" alarm;
    - (c) Instrument indicates a "Low" alarm; or
    - (d) Instrument indicates channel "Deactivated".
  - (2) The CHANNEL FUNCTIONAL TEST shall also demonstrate that control room annunciation occurs (for item a. below only); and that control room CRT indication occurs (if any of the following conditions exist):
    - (a) Instrument indicates measured levels above the alarm/trip setpoint;
    - (b) Instrument indicates an "Equipment Trouble" alarm;
    - (c) Instrument indicates a "Low" alarm; or
    - (d) Instrument indicates channel "Deactivated".
- b. The initial CHANNEL CALIBRATION shall be performed using one or more of the reference standards certified by the National Institute of Standards and Technology or using standards that have been obtained from suppliers that participate in measurements assurance activities with NIST. These standards shall permit calibrating the system over its intended range of energy and measurement range. For subsequent CHANNEL CALIBRATION, sources that have been related to the initial calibration shall be used.
- c. CHANNEL CHECK shall consist of verifying indication of flow during periods of release. CHANNEL CHECK shall be made at least once per 24 hours on days on which continuous, periodic, or batch releases are made.
- d. All requirements in this table apply to each unit.
-

---

## 2.1.2 Liquid Effluent Concentration Control

In accordance with Technical Specifications 5.5.4.b and 5.5.4.c, the concentration of radioactive material released in liquid effluents to UNRESTRICTED AREAS shall be limited at all times to ten times the concentrations specified in 10 CFR 20, Appendix B, Table 2, Column 2 for radionuclides other than dissolved or entrained noble gases. For dissolved or entrained noble gases, the concentration shall be limited to  $1 \times 10^{-4}$   $\mu\text{Ci}/\text{mL}$  total activity.

### 2.1.2.1 Applicability

This limit applies at all times.

### 2.1.2.2 Actions

With the concentration of radioactive material released in liquid effluents to UNRESTRICTED AREAS exceeding the limits stated in Section 2.1.2, immediately restore the concentration to within the stated limits.

This control does not affect shutdown requirements or MODE changes.

### 2.1.2.3 Surveillance Requirements

The radioactivity content of each batch of radioactive liquid waste shall be determined by sampling and analysis in accordance with Table 2-3. The results of radioactive analyses shall be used with the calculational methods in Section 2.3 to assure that the concentration at the point of release is maintained within the limits of Section 2.1.2.

### 2.1.2.4 Basis

This control is provided to ensure that the concentration of radioactive materials released in liquid waste effluents to UNRESTRICTED AREAS will be less than ten times the concentration levels specified in 10 CFR 20, Appendix B, Table 2, Column 2. This limitation provides additional assurance that the levels of radioactive materials in bodies of water in UNRESTRICTED AREAS will result in exposures within (1) the Section II.A design objectives of Appendix I, 10 CFR 50, to a MEMBER OF THE PUBLIC, and (2) the limits of 10 CFR 20.1301 to the population. The concentration limit for dissolved or entrained noble gases is based upon the assumption that Xe-135 is the controlling radioisotope and its MPC in air (submersion) was converted to an equivalent concentration in water using the methods described in International Commission on Radiological Protection (ICRP) Publication 2 (1959). The resulting concentration of  $2 \times 10^{-4}$  was then multiplied by the ratio of the effluent concentration limit for Xe-135, stated in Appendix B, Table 2, Column 1 of 10 CFR 20 (paragraphs 20.1001 to 20.2401), to the MPC for Xe-135, stated in Appendix B, Table II, Column 1 of 10 CFR 20 (paragraphs 20.1 to 20.601), to obtain the limiting concentration of  $1 \times 10^{-4}$   $\mu\text{Ci}/\text{mL}$ .

Table 2-3. Radioactive Liquid Waste Sampling and Analysis Program

| Liquid Release Type                      | Sampling and Analysis Requirements <sup>a,b</sup> |                            |  |  |
|--|---|----------------------------|--|--|
|  | Sampling FREQUENCY                                | Minimum Analysis FREQUENCY | Type of Activity Analysis                      | MINIMUM DETECTABLE CONCENTRATION (MDC) ( $\mu\text{Ci/mL}$ ) |
| <b>A. BATCH RELEASES</b>                 |   |                            |  |  |
| 1. Waste Monitor Tank                    | P<br>Each BATCH                                   | P<br>Each BATCH            | PRINCIPAL GAMMA EMITTERS                       | 5 E-7  |
|  | P<br>One BATCH/M                                  | M                          | I-131  | 1 E-6  |
| 2. Drainage of System                    | P<br>Each BATCH                                   | M<br>COMPOSITE             | Dissolved and Entrained Gases (Gamma Emitters) | 1 E-5  |
|  | P<br>Each BATCH                                   | M<br>COMPOSITE             | H-3  | 1 E-5  |
|  | P<br>Each BATCH                                   | Q<br>COMPOSITE             | Gross Alpha                                    | 1 E-7  |
|  | P<br>Each BATCH                                   | Q<br>COMPOSITE             | Sr-89, Sr-90                                   | 5 E-8  |
|  | P<br>Each BATCH                                   | Q<br>COMPOSITE             | Fe-55  | 1 E-6  |
| <b>B. CONTINUOUS RELEASES</b>            |   |                            |  |  |
| Waste Water Retention Basin <sup>c</sup> | Continuous  | W<br>COMPOSITE             | PRINCIPAL GAMMA EMITTERS                       | 5 E-7  |
|  | M<br>Grab Sample                                  | M                          | I-131  | 1 E-6  |
|  | M<br>Grab Sample                                  | M                          | Dissolved and Entrained Gases (Gamma Emitters) | 1 E-5  |
|  | Continuous  | M<br>COMPOSITE             | H-3  | 1 E-5  |
|  | Continuous  | M<br>COMPOSITE             | Gross Alpha                                    | 1 E-7  |
|  | Continuous  | Q<br>COMPOSITE             | Sr-89, Sr-90                                   | 5 E-8  |
|  | Continuous  | Q<br>COMPOSITE             | Fe-55  | 1 E-6  |

---

Table 2-3 (contd).                      Notation for Table 2-3

---

- a.        All requirements in this table apply to each unit.
- b.        Terms printed in all capital letters are defined in Chapter 10.
- c.        The WWRB will not be considered a release point until there is a confirmed primary to secondary leak. Once a primary to secondary leak has been confirmed, this composite shall be analyzed as specified until the leak is repaired. This surveillance will continue until three consecutive weekly composite samples have shown no activity above the MDC.

---

### 2.1.3 Liquid Effluent Dose Control

In accordance with Technical Specifications 5.5.4.d and 5.5.4.e, the dose or dose commitment to a MEMBER OF THE PUBLIC from radioactive materials in liquid effluents released, from each unit, to UNRESTRICTED AREAS shall be limited:

- a. During any calendar quarter to less than or equal to 1.5 mrem to the total body and to less than or equal to 5 mrem to any organ, and
- b. During any calendar year to less than or equal to 3 mrem to the total body and to less than or equal to 10 mrem to any organ.

#### 2.1.3.1 Applicability

These limits apply at all times.

#### 2.1.3.2 Actions

With the calculated dose from the release of radioactive materials in liquid effluents exceeding any of the limits of Section 2.1.3., prepare and submit to the Nuclear Regulatory Commission within 30 days a special report which identifies the cause(s) for exceeding the limit(s); defines the corrective actions to be taken to reduce the releases; and defines the proposed corrective actions to be taken to assure that subsequent releases will be in compliance with the limits of Section 2.1.3.

This control does not affect shutdown requirements or MODE changes.

#### 2.1.3.3 Surveillance Requirements

At least once per 31 days, cumulative dose contributions from liquid effluents for the current calendar quarter and the current calendar year shall be determined, for each unit, in accordance with Section 2.4.

#### 2.1.3.4 Basis

This control is provided to implement the requirements of Sections II.A, III.A and IV.A of Appendix I, 10 CFR Part 50. The limits stated in Section 2.1.3 implement the guides set forth in Section II.A of Appendix I. The ACTIONS stated in Section 2.1.3.2 provide the required operating flexibility and at the same time implement the guides set forth in Section IV.A of Appendix I to assure that the releases of radioactive material in liquid effluents will be kept "as low as is reasonably achievable." Also, for fresh water sites with drinking water supplies that can be potentially affected by plant operations, there is reasonable assurance that the operation of the facility will not result in radionuclide concentrations in the finished drinking water that are in excess of the requirements of 40 CFR Part 141. The dose calculations in Section 2.4 implement the requirements in Section III.A of Appendix I, which state that conformance with the guides of Appendix I be shown by calculational procedures based on models and data, such that the actual exposure of a MEMBER OF THE PUBLIC through appropriate pathways is unlikely to be substantially underestimated. The equations specified in Section 2.4 for calculating the doses due to the actual release rates of radioactive materials in liquid effluents are consistent with the

---

methodology provided in Regulatory Guide 1.109 (Reference 3) and Regulatory Guide 1.113 (Reference 6).

This control applies to the release of liquid effluents from each unit at the site. The liquid effluents from shared LIQUID RADWASTE TREATMENT SYSTEMS are to be proportioned between the units.

#### 2.1.4 Liquid Radwaste Treatment System Control

In accordance with Technical Specification 5.5.4.f, the LIQUID RADWASTE TREATMENT SYSTEM shall be FUNCTIONAL. The appropriate portions of the system shall be used to reduce radioactivity in liquid wastes prior to their discharge when the projected doses due to the liquid effluent, from each unit, to UNRESTRICTED AREAS would exceed 0.06 mrem to the total body or 0.2 mrem to any organ of a MEMBER OF THE PUBLIC in 31 days.

##### 2.1.4.1 Applicability

This limit applies at all times.

##### 2.1.4.2 Actions

With radioactive liquid waste being discharged without treatment and in excess of the above limits and any portion of the LIQUID RADWASTE TREATMENT SYSTEM not in operation, prepare and submit to the Nuclear Regulatory Commission within 30 days a special report which includes the following information:

- a. Explanation of why liquid radwaste was being discharged without treatment, identification of any NON-FUNCTIONAL equipment or subsystems and the reason for the NON-FUNCTIONALITY,
- b. Action(s) taken to restore the NON-FUNCTIONAL equipment to FUNCTIONAL status, and
- c. Summary description of action(s) taken to prevent a recurrence.

This control does not affect shutdown requirements or MODE changes.

##### 2.1.4.3 Surveillance Requirements

Doses due to liquid releases to UNRESTRICTED AREAS shall be projected at least once per 31 days, in accordance with Section 2.5, during periods in which the LIQUID RADWASTE TREATMENT SYSTEMS are not being fully utilized.

The LIQUID RADWASTE TREATMENT SYSTEM shall be demonstrated FUNCTIONAL by meeting the controls of Sections 2.1.2 and 2.1.3.

##### 2.1.4.4 Basis

The FUNCTIONALITY of the LIQUID RADWASTE TREATMENT SYSTEM ensures that this system will be available for use whenever liquid effluents require treatment prior to release to the UNRESTRICTED AREAS. The requirement that the appropriate portions of this system be used

when specified provides assurance that the releases of radioactive materials in liquid effluents will be kept “as low as is reasonably achievable.” This control implements the requirements of 10 CFR Part 50.36a, General Design Criterion 60 of Appendix A to 10 CFR Part 50, and the design objective given in Section II.D of Appendix I to 10 CFR Part 50. The specified limits governing the use of appropriate portions of the LIQUID RADWASTE TREATMENT SYSTEM were specified as a suitable fraction of the dose design objectives set forth in Section II.A of Appendix I, 10 CFR Part 50, for liquid effluents.

This control applies to the release of radioactive materials in liquid effluents from each unit at the site. For units with shared radwaste systems, the liquid effluents from the shared system are to be proportioned among the units sharing that system.

#### 2.1.5 Major Changes to Liquid Radioactive Waste Treatment Systems

Licensee initiated MAJOR CHANGES TO LIQUID RADIOACTIVE WASTE TREATMENT SYSTEMS:

- a. Shall be reported to the Nuclear Regulatory Commission in the Radioactive Effluent Release Report for the period in which the change was implemented. The discussion of each change shall contain the information described in Section 7.2.2.7.
- b. Shall become effective upon review by the Plant Review Board and approval by the Plant Manager.

---

## 2.2 LIQUID RADWASTE TREATMENT SYSTEM

The Vogtle Electric Generating Plant is located on the west bank of the Savannah River approximately 151 river miles from the Atlantic Ocean. There are two pressurized water reactors on the site. Each unit is served by a separate LIQUID RADWASTE TREATMENT SYSTEM; however, certain components are shared between the two systems. Schematics of the LIQUID RADWASTE TREATMENT SYSTEMS are presented in Figure 2-1 and Figure 2-2. Liquid discharge pathways are shown in Figure 2-3.

All liquid radwastes treated by the LIQUID RADWASTE TREATMENT SYSTEM are collected in 5,000-gallon or 20,000-gallon waste monitor tanks. Releases from the waste monitor tanks are to the discharge line from the blowdown sump, and from there to the Savannah River. The blowdown sump also receives input from the waste water retention basins, turbine plant cooling water blowdown, and nuclear service cooling water blowdown. Additional dilution water is available from the cooling tower makeup water bypass line.

Although no significant quantities of radioactivity are expected in the nuclear service cooling water, the steam generator blowdown processing system, or the turbine building drain system, these effluent pathways are monitored as a precautionary measure. The monitors serving the latter two pathways provide for automatic termination of releases from these systems in the event that radio-activity is detected above predetermined levels. These two systems discharge to the waste water retention basin. Sampling and analysis of releases via all three of these pathways must be sufficient to ensure that the liquid effluent dose limits specified in the controls of Section 2.1.3 are not exceeded.

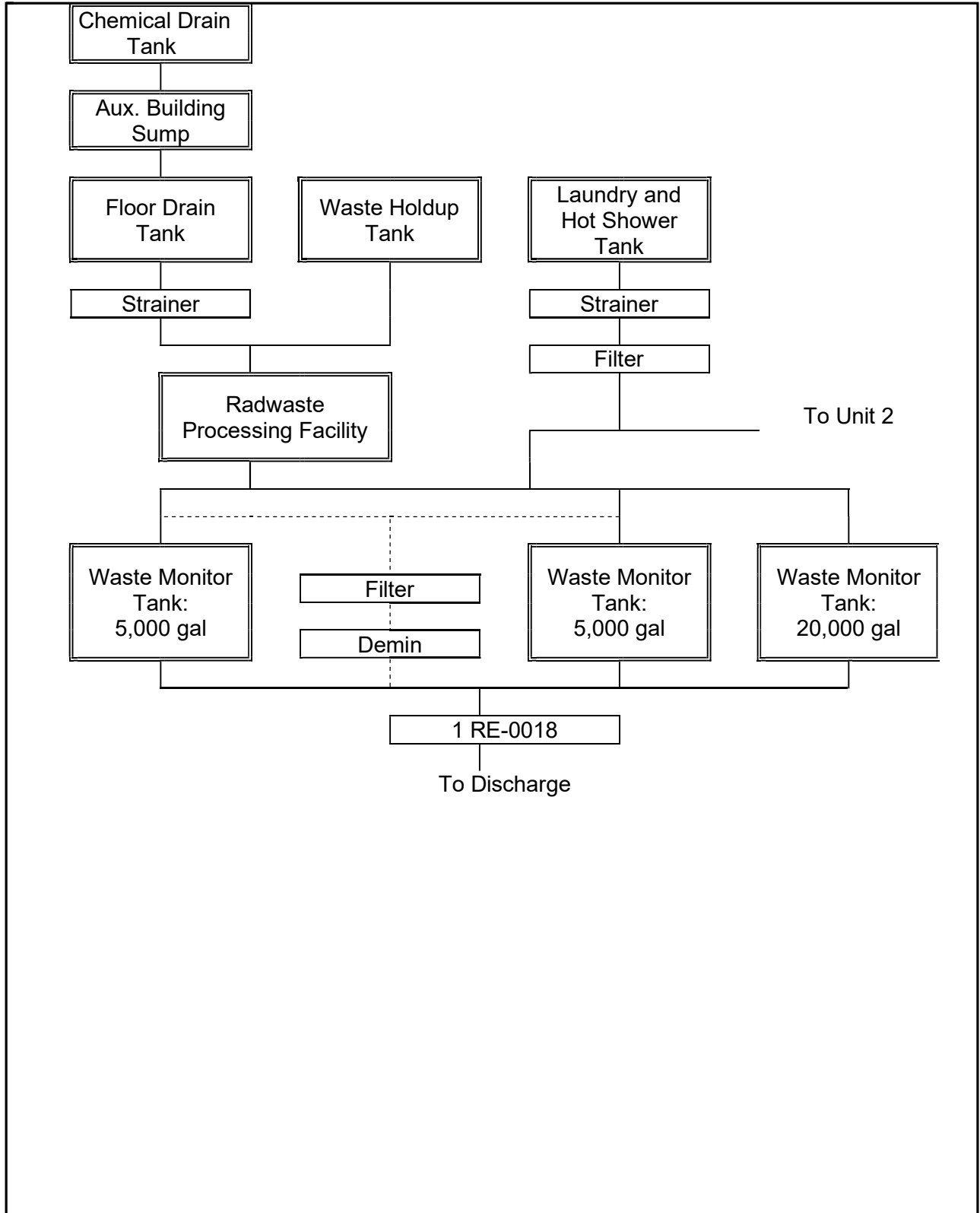

**Figure 2-1.** Unit 1 Liquid Radwaste Treatment System

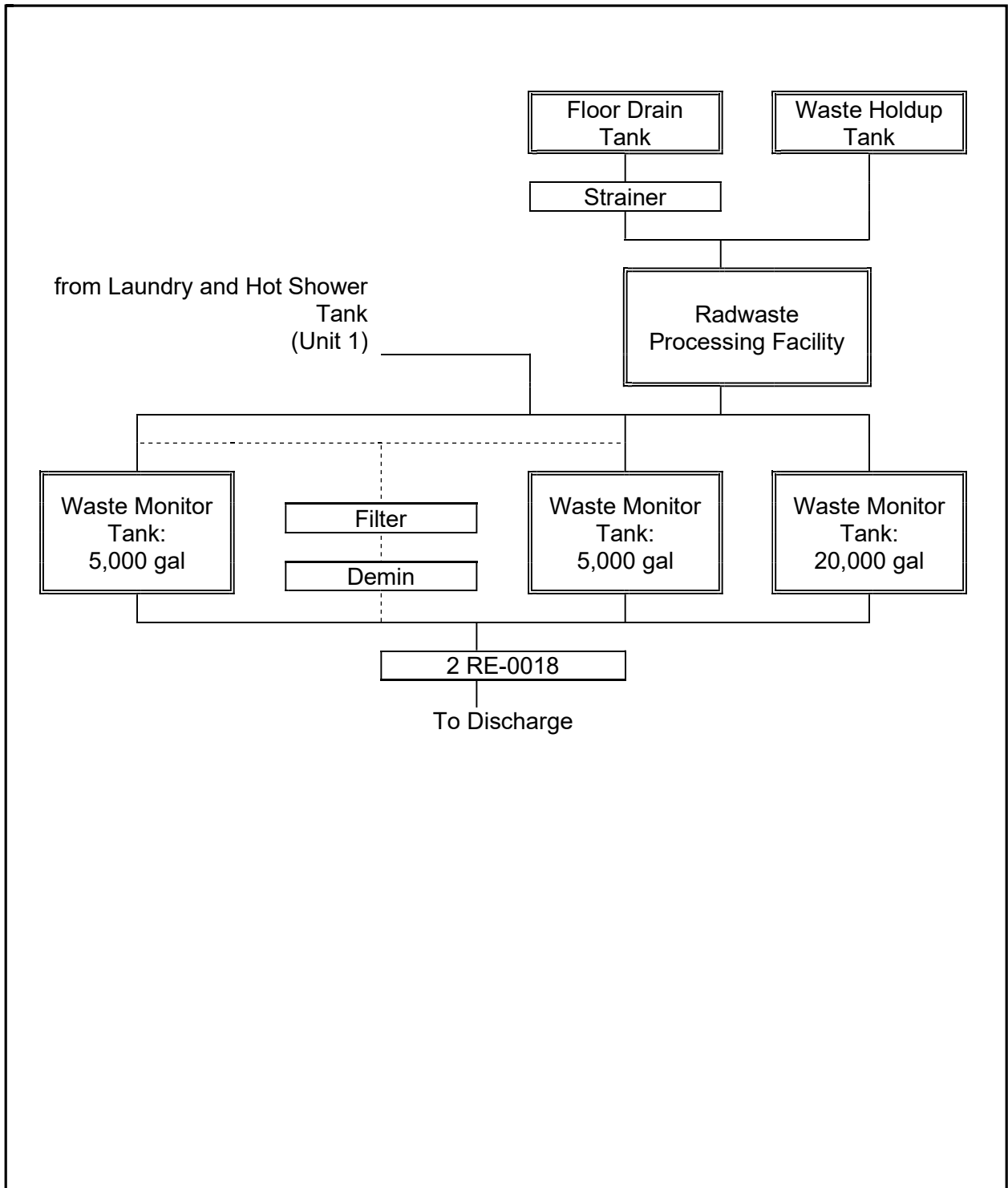

**Figure 2-2.** Unit 2 Liquid Radwaste Treatment System

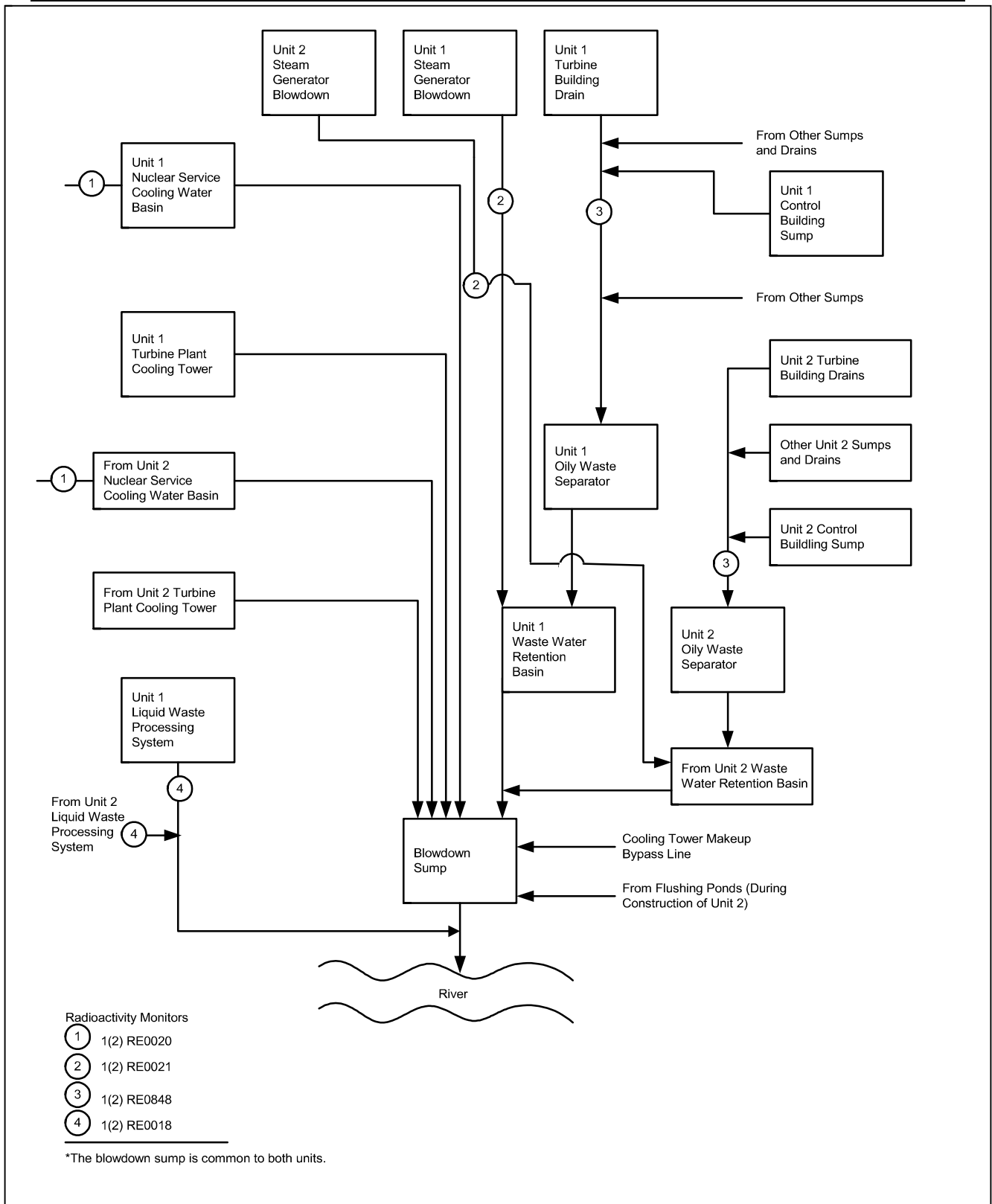

Figure 2-3. Liquid Radwaste Discharge Pathways

---

## 2.3 LIQUID EFFLUENT MONITOR SETPOINTS

### 2.3.1 General Provisions Regarding Setpoints

Liquid monitor setpoints calculated in accordance with the methodology presented in this section will be regarded as upper bounds for the actual high alarm setpoints. That is, a lower value for the high alarm setpoint may be established or retained on the monitor, if desired. Intermediate level setpoints should be established at an appropriate level to give sufficient warning prior to reaching the high alarm setpoint. If no release is planned for a particular pathway, or if there is no detectable activity in the planned release, the monitor setpoint should be established as close to background as practical to prevent spurious alarms, and yet alarm should an inadvertent release occur.

Two basic setpoint methodologies are presented below. For radwaste system discharge monitors, setpoints are determined to assure that the limits of Section 2.1.2 are not exceeded. For monitors on streams that are not expected to contain significant radioactivity, the purpose of the monitor setpoints is to cause an alarm on low levels of radioactivity, and to terminate the release where this is possible. Section 2.1.1 establishes the requirements for liquid effluent monitoring instrumentation. Table 2-4 lists the monitors for which each of the setpoint methodologies is applicable.

---

 Table 2-4. Applicability of Liquid Monitor Setpoint Methodologies
 

---

**Liquid Radwaste Discharge Monitors**

Setpoint Method: Section 2.3.2

Release Type: BATCH

Unit 1 or Unit 2 Liquid Waste Treatment System Effluent

Monitor: 1RE-0018 / 2RE-0018

**Normally Low-Radioactivity Streams with Termination or Diversion upon Alarm**

Setpoint Method: Section 2.3.3

Release Type: CONTINUOUS

Unit 1 or Unit 2 Steam Generator Blowdown Effluent

Monitor: 1RE-0021 / 2RE-0021

Unit 1 or Unit 2 Turbine Building Drain Effluent

Monitor: 1RE-0848 / 2RE-0848

**Normally Low-Radioactivity Streams with Alarm Only**

Setpoint Method: Section 2.3.3

Release Type: CONTINUOUS

Unit 1 or Unit 2 Nuclear Service Cooling Water System EffluentMonitors (2 per unit): 1RE-0020 A and B  
2RE-0020 A and B

## 2.3.2 Setpoints for Radwaste System Discharge Monitors

### 2.3.2.1 Overview of Method

LIQUID RADWASTE TREATMENT SYSTEM effluent line radioactivity monitors are intended to provide alarm and automatic termination of release prior to exceeding the limits specified in Section 2.1.2 at the point of release of the diluted effluent into the UNRESTRICTED AREA. Therefore, their alarm/trip setpoints are established to ensure compliance with the following equation (equation adapted from Addendum to Reference 1):

$$\frac{c \cdot f}{F + f} \leq TF \cdot C_{ECL} \quad (2.1)$$

where:

- $C_{ECL}$  = the Effluent Concentration Limit corresponding to the mix of radionuclides in the effluent being considered for discharge, in  $\mu\text{Ci/mL}$ .
- $c$  = the setpoint, in  $\mu\text{Ci/mL}$ , of the radioactivity monitor measuring the concentration of radioactivity in the effluent line prior to dilution and subsequent release. The setpoint represents a concentration which, if exceeded, could result in concentrations exceeding the limits of Section 2.1.2 in the UNRESTRICTED AREA.
- $f$  = the effluent flowrate at the location of the radioactivity monitor, in gpm.
- $F$  = the dilution stream flowrate which can be assured prior to the release point to the UNRESTRICTED AREA, in gpm. A predetermined dilution flowrate must be assured for use in the calculation of the radioactivity monitor setpoint.
- $TF$  = the tolerance factor selected to allow flexibility in the establishment of a practical monitor setpoint which could accommodate effluent releases at concentrations higher than the ECL values stated in 10 CFR 20, Appendix B, Table 2, Column 2; the tolerance factor must not exceed a value of 10.

While equation (2.1) shows the relationships of the critical parameters that determine the setpoint, it cannot be applied practically to a mixture of radionuclides with different Effluent Concentration Limits (ECLs). For a mixture of radionuclides, equation (2.1) is satisfied in a practicable manner based on the calculated ECL fraction of the radionuclide mixture and the dilution stream flowrate that can be assured for the duration of the release ( $F_d$ ), by calculating the maximum permissible effluent flowrate ( $f_m$ ) and the radioactivity monitor setpoint ( $c$ ).

The setpoint method presented below is applicable to the release of only one tank of liquid radwaste per reactor unit at a given time. Liquid releases must be controlled administratively to ensure that this condition is met; otherwise, the setpoint method may not ensure that the limits of Section 2.1.2 are not exceeded.

### 2.3.2.2 Setpoint Calculation Steps

**Step 1:** Determine the radionuclide concentrations in the liquid waste being considered for release in accordance with the sampling and analysis requirements of Section 2.1.2.

All liquid radwastes treated by the LIQUID RADWASTE TREATMENT SYSTEM are collected in waste monitor tanks for sampling and analysis. The 5,000-gallon waste monitor tanks are recirculated for a minimum of 30 minutes, and the 20,000-gallon waste monitor tanks are recirculated for a minimum of 45 minutes. This mixing assures that a representative sample can be taken from the tank.

The total concentration of the liquid waste is determined by the results of all required analyses on the collected sample, as follows:

$$\sum_i C_i = C_a + \sum_s C_s + C_f + C_t + \sum_g C_g \quad (2.2)$$

where:

- $C_a$  = the gross concentration of alpha emitters in the liquid waste, not less than that measured in the most recent applicable composite sample.
- $C_s$  = the concentration of strontium radioisotope  $s$  (Sr-89 or Sr-90) in the liquid waste, not less than that measured in the most recent applicable composite sample.
- $C_f$  = the concentration of Fe-55 in the liquid waste, not less than that measured in the most recent applicable composite sample.
- $C_t$  = the concentration of H-3 in the liquid waste, not less than that measured in the most recent applicable composite sample.
- $C_g$  = the concentration of gamma emitter  $g$  in the liquid waste as measured by gamma ray spectroscopy performed on the sample for the release under consideration.

The  $C_g$  term will be included in the analysis of each waste sample; terms for gross concentrations of alpha emitters, Sr-89, Sr-90, Fe-55, and tritium will be included in accordance with the sampling and analysis program required for the waste stream (see Section 2.1.2). For each analysis, only radionuclides identified and detected above background for the given measurement should be included in the calculation. When using the alternate setpoint methodology of step 5.b, the historical maximum values of  $C_a$ ,  $C_s$ ,  $C_f$ , and  $C_t$  shall be used.

**Step 2:** Determine the required dilution factor for the mix of radionuclides detected in the waste.

Measured radionuclide concentrations are used to calculate ECL fractions. The ECL fractions are used along with a safety factor to calculate the required dilution factor; this is the minimum ratio of dilution flowrate to waste flowrate that must be maintained throughout the release to ensure that the limits of Section 2.1.2 are not exceeded at the point of discharge into the UNRESTRICTED AREA. The required dilution factor, RDF, is calculated as the sum of the dilution factors required for gamma emitters ( $RDF_\gamma$ ) and for non-gamma-emitters ( $RDF_{n\gamma}$ ):

$$RDF = \left[ \sum_i \frac{C_i}{ECL_i} \right] \div [(SF)(TF)]$$

$$= RDF_\gamma + RDF_{ng} \tag{2.3}$$

$$RDF_\gamma = \frac{\left[ \sum_g \frac{C_g}{ECL_g} \right]}{(SF)(TF)} \tag{2.4}$$

where:

$$RDF_{ng} = \frac{\left[ \frac{C_a}{ECL_a} + \sum_s \frac{C_s}{ECL_s} + \frac{C_f}{ECL_f} + \frac{C_t}{ECL_t} \right]}{(SF)(TF)} \tag{2.5}$$

$C_i$  = the measured concentration of radionuclide  $i$  as defined in step 1, in  $\mu\text{Ci/mL}$ . The  $C_a$ ,  $C_s$ ,  $C_f$ , and  $C_t$  terms will be included in the calculation as appropriate.

$ECL_i$  = the Effluent Concentration Limit for radionuclide  $i$  from 10 CFR Part 20, Appendix B, Table 2, Column 2 (except for noble gases as discussed below). In the absence of information regarding the solubility classification of a given radionuclide in the waste stream, the solubility class with the lowest ECL shall be assumed. For dissolved or entrained noble gases, the concentration shall be limited to  $1 \times 10^{-4} \mu\text{Ci/mL}$ . For gross alpha, the ECL shall be  $2 \times 10^{-9} \mu\text{Ci/mL}$ ; if specific alpha-emitting radionuclides are measured, the ECL for the specific radionuclide(s) should be used.

SF = the safety factor selected to compensate for statistical fluctuations and errors of measurement. The value for the safety factor must be between 0 and 1. A value of 0.5 is reasonable for liquid releases; a more precise value may be developed if desired.

TF = the tolerance factor (as defined in Section 2.3.2.1).

**Step 3:** Determine the release-specific assured dilution stream flowrate.

Determine the dilution stream flowrate that can be assured during the release period, designated  $F_d$ ; this value is the setpoint for the dilution stream flowrate measurement device.

If simultaneous radioactive releases are planned from the same or different reactor units, the dilution stream must be allocated among all the simultaneous releases. There will only be one such release per unit at a given time, unless there is detectable radioactivity in one of the normally low-radioactivity streams (see Section 2.3.3). Allocation of the dilution stream to multiple release paths is accomplished as follows:

$$F_{dp} = F_d (AF_p) \tag{2.6}$$

where:

- $F_{dp}$  = the dilution flowrate allocated to release pathway p, in gpm.
- $AF_p$  = the dilution allocation factor for release pathway p.  $AF_p$  may be assigned any value between 0 and 1 for each active release pathway, under the condition that the sum of the  $AF_p$  for all active release pathways for the entire plant site does not exceed 1.
- $F_d$  = the assured minimum dilution flow for the unit, in gpm.

In the normal case in which the only release pathways with detectable radioactivity are the LIQUID RADWASTE TREATMENT SYSTEMS of each unit,  $AF_p$  for each unit may be assigned the value of 0.5 to permit releases from either unit to be made without regard to any releases from the other unit; if only one unit's LIQUID RADWASTE TREATMENT SYSTEM is releasing at a given time, its  $AF_p$  may be increased proportionately. If more precise allocation factor values are desired, they may be determined based on the relative radiological impact of each active release pathway; this may be approximated by multiplying the RDF of each effluent stream by its respective planned release flowrate, and comparing these values. If only one simultaneous release is being made, its  $AF_p$  may be assigned the value of 1, making  $F_{dp}$  equal to  $F_d$ .

For the case where  $RDF \leq 1$ , the planned release meets the limits of Section 2.1.2 without dilution, and *could* be released with any desired effluent flowrate and dilution flowrate. However, in order to maintain individual doses due to liquid effluent releases as low as is reasonably achievable, no releases with detectable radioactivity *should* be made if the assured dilution flowrate,  $F_d$ , is less than 12,000 gpm.

**Step 4:** Determine the maximum allowable waste discharge flowrate.

For the case where  $RDF > 1$ , the maximum permissible effluent discharge flowrate for this release pathway,  $f_{mp}$  (in gpm), is calculated as follows:

$$f_{mp} = \frac{F_{dp}}{(RDF - 1)} \tag{2.7}$$

For the case  $RDF \leq 1$ , equation (2.7) is not valid. However, as discussed above, when  $RDF \leq 1$ , the release may be made at full discharge pump capacity; the radioactivity monitor setpoint must still be calculated in accordance with Step 5 below.

**NOTE 1:** Discharge flowrates are actually limited by the discharge pump capacity. When the calculated maximum permissible release flowrate exceeds the pump capacity, the release may be made at full capacity. Discharge flowrates less than the pump capacity must be achieved by throttling if this is available; if throttling is not available, the release may not be made as planned.

**NOTE 2:** If, at the time of the planned release, there is detectable radioactivity due to plant operations in the dilution stream, the diluting capacity of the dilution stream is diminished. (In addition, sampling and analysis of the other radioactive effluents affecting the dilution stream must be sufficient to ensure that the liquid effluent dose limits specified in the controls of Section 2.1.3 are not exceeded.) Under

these conditions, equation (2.7) must be modified to account for the radioactivity present in the dilution stream prior to the introduction of the planned release:

$$f_{mp} = \frac{F_{dp}}{(RDF-1)} \left( 1 - \sum_r \left[ \frac{f_r}{F_d} \sum_i \left( \frac{C_{ir}}{ECL_i} \right) \right] \right) \quad (2.8)$$

where:

$C_{ir}$  = the measured concentration of radionuclide  $i$  in release pathway  $r$  that is contributing to radioactivity in the dilution stream.

$f_r$  = the effluent discharge flowrate of release pathway  $r$ .

If the entire dilution stream contains detectable activity due to plant operations, whether or not its source is identified,  $f_r = F_d$ , and  $C_{ir}$  is the concentration in the total dilution system. This note does not apply: a) if the RDF of the planned release is  $\leq 1$ ; or b) if the release contributing radioactivity to the dilution stream has been accounted for by the assignment of an allocation factor.

**Step 5:** Determine the maximum radioactivity monitor setpoint concentration.

Based on the values determined in previous steps, the radioactivity monitor setpoint for the planned release is calculated to ensure that the limits of Section 2.1.2 will not be exceeded. Because the radioactivity monitor responds primarily to gamma radiation, the monitor setpoint  $c_p$  for release pathway  $p$  (in  $\mu\text{Ci/mL}$ ) is based on the concentration of gamma emitters in the waste stream, as follows:

$$c_p = A_p \sum_g c_g \quad (2.9)$$

where:

$A_p$  = an adjustment factor which will allow the setpoint to be established in a practical manner to prevent spurious alarms while allowing a margin between measured concentrations and the limits of Section 2.1.2.

**Step 5.a.** If the concentration of gamma emitters in the effluent to be released is sufficient that the high alarm setpoint can be established at a level that will prevent spurious alarms,  $A_p$  should be calculated as follows:

$$A_p = \frac{1}{RDF} \times ADF \quad (2.10)$$

$$= \frac{1}{RDF} \times \frac{(F_{dp} + f_{ap})}{f_{ap}}$$

where:

- ADF = the assured dilution factor.
- $f_{ap}$  = the anticipated actual discharge flowrate for the planned release (in gpm), a value less than  $f_{mp}$ . The release must then be controlled so that the actual effluent discharge flowrate does not exceed  $f_{ap}$  at any time.

Step 5.b. Alternatively,  $A_p$  may be calculated as follows:

$$A_p = \frac{ADF - RDF_{ny}}{RDF_{\gamma}} \tag{2.11}$$

Step 5.c. Evaluate the computed value of  $A_p$  as follows:

If  $A_p \geq 1$ , calculate the monitor setpoint,  $c_p$ . However, if  $c_p$  is within about 10 percent of  $C_g$ , it may be impractical to use this value of  $c_p$ . This situation indicates that measured concentrations are approaching values which would cause limits of Section 2.1.2 to be exceeded. Therefore, steps should be taken to reduce potential concentrations at the point of discharge; these steps may include decreasing the planned effluent discharge flowrate, increasing the dilution stream flowrate, postponing simultaneous releases, and/or decreasing the effluent concentrations by further processing the liquid planned for release. Alternatively, allocation factors for the active liquid release pathways may be reassigned. When one or more of these actions has been taken, repeat Steps 1–5 to calculate a new radioactivity monitor setpoint.

If  $A_p < 1$ , the release may not be made as planned. Consider the alternatives discussed in the paragraph above, and calculate a new setpoint based on the results of the actions taken.

### 2.3.2.3 Use of the Calculated Setpoint

The setpoint calculated above is in the units  $\mu\text{Ci/mL}$ . The monitor actually measures a count rate, subtracts a predetermined background count rate, and multiplies by a calibration factor to convert from count rate to  $\mu\text{Ci/mL}$ .

Initial calibration of the monitors by the manufacturer and Georgia Power Company utilized NIST-traceable liquid solutions with gamma ray emissions over the range 0.08 to 1.33 MeV, in the exact geometry of each production monitor. The calibration factor is a function of the radionuclide mix in the liquid to be released, and will be calculated for the monitor based on the results of the pre-release sample results from the laboratory gamma-ray spectrometer system. The mix-dependent calibration factor will be used as the gain factor in the PERMS monitor, or used to modify the

---

calculated base monitor setpoint so that the default calibration factor in the PERMS monitor can be left unchanged.

Notwithstanding the initial calibration, monitor calibration data for conversion between count rate and concentration *may* include operational data obtained from determining the monitor response to stream concentrations measured by liquid sample analysis. In all cases, monitor background must be controlled so that the monitor is capable of responding to concentrations in the range of the setpoint value.

### 2.3.3 Setpoints for Monitors on Normally Low-Radioactivity Streams

Radioactivity in these streams (listed in Table 2-4 above) is expected to be at very low levels, generally below detection limits. Accordingly, the purpose of these monitors is to alarm upon the occurrence of significant radioactivity in these streams, and to terminate or divert the release where this is possible.

#### 2.3.3.1 Normal Conditions

When radioactivity in one of these streams is at its normal low level, its radioactivity monitor setpoint should be established as close to background as practical to prevent spurious alarms, and yet alarm should an inadvertent release occur.

#### 2.3.3.2 Conditions Requiring an Elevated Setpoint

Under the following conditions, radionuclide concentrations must be determined and an elevated radioactivity monitor setpoint determined for these pathways:

- For streams that can be diverted or isolated, a new monitor setpoint must be established when it is desired to discharge the stream directly to the dilution water even though the radioactivity in the stream exceeds the level which would normally be diverted or isolated.
- For streams that cannot be diverted or isolated, a new monitor setpoint must be established whenever: the radioactivity in the stream becomes detectable above the background levels of the applicable laboratory analyses; or the associated radioactivity monitor detects activity in the stream at levels above the established alarm setpoint.

When an elevated monitor setpoint is required for any of these effluent streams, it should be determined in the same manner as described in Section 2.3.2. However, special consideration must be given to Step 3. An allocation factor must be assigned to the normally low-radioactivity release pathway under consideration, and allocation factors for other release pathways discharging simultaneously must be adjusted downward (if necessary) to ensure that the sum of the allocation factors does not exceed 1. Sampling and analysis of the normally low-radioactivity streams must be sufficient to ensure that the liquid effluent dose limits specified in the controls of Section 2.1.3 are not exceeded.

2.4 LIQUID EFFLUENT DOSE CALCULATIONS

The following sub-sections present the methods required for liquid effluent dose calculations, in deepening levels of detail. Applicable site-specific pathways and parameter values for the calculation of  $D_\tau$ ,  $A_{i\tau}$ , and  $CF_{iv}$  are summarized in Table 2-5.

2.4.1 Calculation of Dose

The dose limits for a MEMBER OF THE PUBLIC specified in Section 2.1.3 are on a per-unit basis. Therefore, the doses calculated in accordance with this section must be determined and recorded on a per-unit basis, including apportionment of releases shared between the two units.

For the purpose of implementing Section 2.1.3, the dose to the maximum exposed individual due to radionuclides identified in liquid effluents released from each unit to UNRESTRICTED AREAS will be calculated as follows (equation from Reference 1, page 15):

$$D_\tau = \sum_i A_{i\tau} \left[ \sum_{l=1}^m (\Delta t_l C_{il} F_l) \right] \tag{2.12}$$

where:

- $D_\tau$  = the cumulative dose commitment to the total body or to any organ  $\tau$ , in mrem, due to radioactivity in liquid effluents released during the total of the  $m$  time periods  $\Delta t_l$ .
- $A_{i\tau}$  = the site-related adult ingestion dose commitment factor, for the total body or for any organ  $\tau$ , due to identified radionuclide  $i$ , in (mrem·mL)/(h· $\mu$ Ci). Methods for the calculation of  $A_{i\tau}$  are presented below in Section 2.4.2. The values of  $A_{i\tau}$  to be used in dose calculations for releases from the plant site are listed in Table 2-8.
- $\Delta t_l$  = the length of time period  $l$ , over which  $C_{il}$  and  $F_l$  are averaged for liquid releases, in h.
- $C_{il}$  = the average concentration of radionuclide  $i$  in undiluted liquid effluent during time period  $l$ , in  $\mu$ Ci/mL. Only radionuclides identified and detected above background in their respective samples should be included in the calculation.
- $F_l$  = the near-field average dilution factor in the receiving water of the UNRESTRICTED AREA:

$$F_l = \frac{f_t}{F_t \times Z} \tag{2.13}$$

where:

- $f_t$  = the average undiluted liquid waste flowrate actually observed during the period of radioactivity release, in gpm.

- $F_t$  = the average dilution stream flowrate actually observed during the period of radioactivity release, in gpm. If simultaneous releases from both units occur, the dilution stream flowrate  $F_t$  must be allocated between them. In such cases,  $F_i$  is unit-specific.
- $Z$  = the applicable dilution factor for the receiving water body, in the near field of the discharge structure, during the period of radioactivity release, from Table 2-5.

NOTE: In equation (2.13), the product ( $F_t \times Z$ ) is limited to 1000 cfs (= 448,000 gpm) or less. (Reference 1, Section 4.3.)

#### 2.4.2 Calculation of $A_{it}$

The site-related adult ingestion dose commitment factor,  $A_{it}$ , is calculated as follows (equation adapted from Reference 1, page 16, by addition of the irrigated garden vegetation pathway):

$$A_{it} = 1.14 \times 10^5 \left( \frac{U_w}{D_w} e^{-\lambda_i t_w} + U_f B F_i e^{-\lambda_i t_f} + U_v C F_{iv} \right) D F_{it} \quad (2.14)$$

where:

- $1.14 \times 10^5$  = a units conversion factor, determined by:  
 $10^6 \text{ pCi}/\mu\text{Ci} \times 10^3 \text{ mL/L} \div 8760 \text{ h/y}$ .
- $U_w$  = the adult drinking water consumption rate applicable to the plant site (L/y).
- $D_w$  = the dilution factor from the near field of the discharge structure for the plant site to the potable water intake location.
- $\lambda_i$  = the decay constant for radionuclide  $i$  ( $\text{h}^{-1}$ ). Values of  $\lambda_i$  used in effluent calculations should be based on decay data from a recognized and current source, such as Reference 20.
- $t_w$  = the transit time from release to receptor for potable water consumption (h).
- $U_f$  = the adult rate of fish consumption applicable to the plant site (kg/y).
- $B F_i$  = the bioaccumulation factor for radionuclide  $i$  applicable to freshwater fish in the receiving water body for the plant site, in  $(\text{pCi/kg})/(\text{pCi/L}) = (\text{L/kg})$ . For specific values applicable to the plant site, see Table 2-6.
- $t_f$  = the transit time from release to receptor for fish consumption (h).
- $U_v$  = the adult consumption rate for irrigated garden vegetation applicable to the plant site (kg/y).

- $CF_{iv}$  = the concentration factor for radionuclide  $i$  in irrigated garden vegetation, as applicable to the vicinity of the plant site, in (pCi/kg)/(pCi/L). Methods for calculation of  $CF_{iv}$  are presented below in Section 2.4.3.
- $DF_{\tau}$  = the dose conversion factor for radionuclide  $i$  for adults, in organ  $\tau$  (mrem/pCi). For specific values, see Table 2-7.

### 2.4.3 Calculation of $CF_{iv}$

The concentration factor for radionuclide  $i$  in irrigated garden vegetation,  $CF_{iv}$  in (L/kg), is calculated as follows:

- For radionuclides other than tritium (equation adapted from Reference 3, equations A-8 and A-9):

$$CF_{iv} = M \cdot I \left[ \frac{r \left( 1 - e^{-\lambda_{Ei} t_c} \right)}{Y_v \lambda_{Ei}} + \frac{f_i B_{iv} \left( 1 - e^{-\lambda_i t_b} \right)}{P \lambda_i} \right] e^{-\lambda_i t_h} \quad (2.15)$$

- For tritium (equation adapted from Reference 3, equations A-9 and A-10):

$$CF_{iv} = M \cdot L_v \quad (2.16)$$

where:

- $M$  = the additional river dilution factor from the near field of the discharge structure for the plant site to the point of irrigation water usage.
- $I$  = the average irrigation rate during the growing season (L)/(m<sup>2</sup>·h).
- $r$  = the fraction of irrigation-deposited activity retained on the edible portions of leafy garden vegetation.
- $Y_v$  = the areal density (agricultural productivity) of leafy garden vegetation (kg/m<sup>2</sup>)
- $f_i$  = the fraction of the year that garden vegetation is irrigated.
- $B_{iv}$  = the crop to soil concentration factor applicable to radionuclide  $i$  (pCi/kg garden vegetation)/(pCi/kg soil).
- $P$  = the effective surface density of soil (kg/m<sup>2</sup>).
- $\lambda_i$  = the decay constant for radionuclide  $i$  (h<sup>-1</sup>). Values of  $\lambda_i$  used in effluent calculations should be based on decay data from a recognized and current source, such as Reference 20.
- $\lambda_w$  = the rate constant for removal of activity from plant leaves by weathering (h<sup>-1</sup>).
- $\lambda_{Ei}$  = the effective removal rate for activity deposited on crop leaves (h<sup>-1</sup>) calculated as:  
 $\lambda_{Ei} = \lambda_i + \lambda_w$ .

- $t_e$  = the period of leafy garden vegetation exposure during the growing season (h).
- $t_b$  = the period of long-term buildup of activity in soil (h).
- $t_h$  = the time between harvest of garden vegetation and human consumption (h).
- $L_v$  = the water content of leafy garden vegetation edible parts (L/kg).

Table 2-5. Parameters for Calculation of Doses Due to Liquid Effluent Releases

**Dose Calculation Receptor Locations:**

- Fish: Vicinity of plant discharge
- Drinking Water: 112 miles downstream, at Beaufort, SC (Reference 12)
- Irrigated Garden Vegetation: None (Reference 12)

**Numerical Parameters:**

| <u>Parameter</u> | <u>Value</u>  | <u>Reference</u>   |
|------------------|---|--|
| Z                | 10, for May through December<br>20, for January through April | Ref. 11  |
| $U_w$            | 730 L/y   | Ref 3  |
| $D_w$            | 8   | Ref. 7   |
| $t_w$            | 48 h  | Ref. 3, Sec. A.2; Ref. 8                                     |
| $U_f$            | 21 kg/y   | Ref. 3, Table E-5  |
| $t_f$            | 24 h  | Ref. 3, Sec. A.2   |
| $U_v$            | 0 kg/y *  | Ref. 12  |
| M                | 1.0 +   |  |
| I                | No value **   |  |
| r                | 0.25  | Ref. 3, Table E-15.  |
| $Y_v$            | 2.0 kg/m <sup>2</sup>   | Ref. 3, Table E-15   |
| $f_i$            | 1.0 +   |  |
| P                | 240 kg/m <sup>2</sup>   | Ref. 3, Table E-15   |
| $\lambda_w$      | 0.0021 h <sup>-1</sup> (i.e., half-life of 14 d)              | Ref. 3, Table E-15   |
| $t_e$            | 1440 h (= 60 d)   | Ref. 3, Table E-15   |
| $t_b$            | 1.31 x 10 <sup>5</sup> h (= 15 y)                             | Ref. 3, Table E-15   |
| $t_h$            | 24 h  | Ref. 3, Table E-15   |
| $L_v$            | 0.92 L/kg   | Based on Ref. 21, Table 5.16<br>(for lettuce, cabbage, etc.) |

- \* - Because there is no irrigated garden vegetation pathway downstream of the plant site, the consumption of irrigated garden vegetation is set to zero, and the other pathway parameters are defaults.
- + - There is no established default value for this parameter. The most conservative physically realistic value is 1.0.

Table 2-6. Element Transfer Factors

| Element | Freshwater Fish |
|---------|-----------------|
|         | $BF_i^*$        |
| H       | 9.0 E-01        |
| C       | 4.6 E+03        |
| Na      | 1.0 E+02        |
| P       | 3.0 E+03        |
| Cr      | 2.0 E+02        |
| Mn      | 4.0 E+02        |
| Fe      | 1.0 E+02        |
| Co      | 5.0 E+01        |
| Ni      | 1.0 E+02        |
| Cu      | 5.0 E+01        |
| Zn      | 2.0 E+03        |
| Br      | 4.2 E+02        |
| Rb      | 2.0 E+03        |
| Sr      | 3.0 E+01        |
| Y       | 2.5 E+01        |
| Zr      | 3.3 E+00        |
| Nb      | 5.5 E+02        |
| Mo      | 1.0 E+01        |
| Tc      | 1.5 E+01        |
| Ru      | 1.0 E+01        |
| Rh      | 1.0 E+01        |
| Ag      | 2.3 E+00        |
| Sb      | 2.0 E+02        |
| Te      | 4.0 E+02        |
| I       | 1.5 E+01        |
| Cs      | 2.0 E+03        |
| Ba      | 4.0 E+00        |
| La      | 2.5 E+01        |
| Ce      | 1.0 E+00        |
| Pr      | 2.5 E+01        |
| Nd      | 2.5 E+01        |
| W       | 1.2 E+03        |
| Np      | 1.0 E+01        |

\* - Bioaccumulation Factors for freshwater fish, in (pCi/kg)/(pCi/L). They are obtained from Reference 3 (Table A-1), except as follows: Reference 9 for P; Reference 2 (Table A-8) for Ag; and Reference 10 for Nb and Sb.

Table 2-7. Adult Ingestion Dose Factors

| Nuclide | Bone     | Liver    | T. Body  | Thyroid  | Kidney   | Lung     | GI-LLI   |
|---------|----------|----------|----------|----------|----------|----------|----------|
| H-3     | No Data  | 1.05E-07 | 1.05E-07 | 1.05E-07 | 1.05E-07 | 1.05E-07 | 1.05E-07 |
| C-14    | 2.84E-06 | 5.68E-07 | 5.68E-07 | 5.68E-07 | 5.68E-07 | 5.68E-07 | 5.68E-07 |
| Na-24   | 1.70E-06 | 1.70E-06 | 1.70E-06 | 1.70E-06 | 1.70E-06 | 1.70E-06 | 1.70E-06 |
| P-32    | 1.93E-04 | 1.20E-05 | 7.46E-06 | No Data  | No Data  | No Data  | 2.17E-05 |
| Cr-51   | No Data  | No Data  | 2.66E-09 | 1.59E-09 | 5.86E-10 | 3.53E-09 | 6.69E-07 |
| Mn-54   | No Data  | 4.57E-06 | 8.72E-07 | No Data  | 1.36E-06 | No Data  | 1.40E-05 |
| Mn-56   | No Data  | 1.15E-07 | 2.04E-08 | No Data  | 1.46E-07 | No Data  | 3.67E-06 |
| Fe-55   | 2.75E-06 | 1.90E-06 | 4.43E-07 | No Data  | No Data  | 1.06E-06 | 1.09E-06 |
| Fe-59   | 4.34E-06 | 1.02E-05 | 3.91E-06 | No Data  | No Data  | 2.85E-06 | 3.40E-05 |
| Co-58   | No Data  | 7.45E-07 | 1.67E-06 | No Data  | No Data  | No Data  | 1.51E-05 |
| Co-60   | No Data  | 2.14E-06 | 4.72E-06 | No Data  | No Data  | No Data  | 4.02E-05 |
| Ni-63   | 1.30E-04 | 9.01E-06 | 4.36E-06 | No Data  | No Data  | No Data  | 1.88E-06 |
| Ni-65   | 5.28E-07 | 6.86E-08 | 3.13E-08 | No Data  | No Data  | No Data  | 1.74E-06 |
| Cu-64   | No Data  | 8.33E-08 | 3.91E-08 | No Data  | 2.10E-07 | No Data  | 7.10E-06 |
| Zn-65   | 4.84E-06 | 1.54E-05 | 6.96E-06 | No Data  | 1.03E-05 | No Data  | 9.70E-06 |
| Zn-69   | 1.03E-08 | 1.97E-08 | 1.37E-09 | No Data  | 1.28E-08 | No Data  | 2.96E-09 |
| Br-83   | No Data  | No Data  | 4.02E-08 | No Data  | No Data  | No Data  | 5.79E-08 |
| Br-84   | No Data  | No Data  | 5.21E-08 | No Data  | No Data  | No Data  | 4.09E-13 |
| Br-85   | No Data  | No Data  | 2.14E-09 | No Data  | No Data  | No Data  | No Data  |
| Rb-86   | No Data  | 2.11E-05 | 9.83E-06 | No Data  | No Data  | No Data  | 4.16E-06 |
| Rb-88   | No Data  | 6.05E-08 | 3.21E-08 | No Data  | No Data  | No Data  | 8.36E-19 |
| Rb-89   | No Data  | 4.01E-08 | 2.82E-08 | No Data  | No Data  | No Data  | 2.33E-21 |
| Sr-89   | 3.08E-04 | No Data  | 8.84E-06 | No Data  | No Data  | No Data  | 4.94E-05 |
| Sr-90   | 7.58E-03 | No Data  | 1.86E-03 | No Data  | No Data  | No Data  | 2.19E-04 |
| Sr-91   | 5.67E-06 | No Data  | 2.29E-07 | No Data  | No Data  | No Data  | 2.70E-05 |

All values are in (mrem/pCi ingested). They are obtained from Reference 3 (Table E-11), except as follows: Reference 2 (Table A-3) for Rh-105, Sb-124, and Sb-125.

Table 2-7 (contd). Adult Ingestion Dose Factors

| Nuclide | Bone     | Liver    | T.Body   | Thyroid  | Kidney   | Lung     | GI-LLI   |
|---------|----------|----------|----------|----------|----------|----------|----------|
| Sr-92   | 2.15E-06 | No Data  | 9.30E-08 | No Data  | No Data  | No Data  | 4.26E-05 |
| Y-90    | 9.62E-09 | No Data  | 2.58E-10 | No Data  | No Data  | No Data  | 1.02E-04 |
| Y-91m   | 9.09E-11 | No Data  | 3.52E-12 | No Data  | No Data  | No Data  | 2.67E-10 |
| Y-91    | 1.41E-07 | No Data  | 3.77E-09 | No Data  | No Data  | No Data  | 7.76E-05 |
| Y-92    | 8.45E-10 | No Data  | 2.47E-11 | No Data  | No Data  | No Data  | 1.48E-05 |
| Y-93    | 2.68E-09 | No Data  | 7.40E-11 | No Data  | No Data  | No Data  | 8.50E-05 |
| Zr-95   | 3.04E-08 | 9.75E-09 | 6.60E-09 | No Data  | 1.53E-08 | No Data  | 3.09E-05 |
| Zr-97   | 1.68E-09 | 3.39E-10 | 1.55E-10 | No Data  | 5.12E-10 | No Data  | 1.05E-04 |
| Nb-95   | 6.22E-09 | 3.46E-09 | 1.86E-09 | No Data  | 3.42E-09 | No Data  | 2.10E-05 |
| Mo-99   | No Data  | 4.31E-06 | 8.20E-07 | No Data  | 9.76E-06 | No Data  | 9.99E-06 |
| Tc-99m  | 2.47E-10 | 6.98E-10 | 8.89E-09 | No Data  | 1.06E-08 | 3.42E-10 | 4.13E-07 |
| Tc-101  | 2.54E-10 | 3.66E-10 | 3.59E-09 | No Data  | 6.59E-09 | 1.87E-10 | 1.10E-21 |
| Ru-103  | 1.85E-07 | No Data  | 7.97E-08 | No Data  | 7.06E-07 | No Data  | 2.16E-05 |
| Ru-105  | 1.54E-08 | No Data  | 6.08E-09 | No Data  | 1.99E-07 | No Data  | 9.42E-06 |
| Ru-106  | 2.75E-06 | No Data  | 3.48E-07 | No Data  | 5.31E-06 | No Data  | 1.78E-04 |
| Rh-105  | 1.22E-07 | 8.86E-08 | 5.83E-08 | No Data  | 3.76E-07 | No Data  | 1.41E-05 |
| Ag-110m | 1.60E-07 | 1.48E-07 | 8.79E-08 | No Data  | 2.91E-07 | No Data  | 6.04E-05 |
| Sb-124  | 2.81E-06 | 5.30E-08 | 1.11E-06 | 6.79E-09 | No Data  | 2.18E-06 | 7.95E-05 |
| Sb-125  | 2.23E-06 | 2.40E-08 | 4.48E-07 | 1.98E-09 | No Data  | 2.33E-04 | 1.97E-05 |
| Te-125m | 2.68E-06 | 9.71E-07 | 3.59E-07 | 8.06E-07 | 1.09E-05 | No Data  | 1.07E-05 |
| Te-127m | 6.77E-06 | 2.42E-06 | 8.25E-07 | 1.73E-06 | 2.75E-05 | No Data  | 2.27E-05 |
| Te-127  | 1.10E-07 | 3.95E-08 | 2.38E-08 | 8.15E-08 | 4.48E-07 | No Data  | 8.68E-06 |
| Te-129m | 1.15E-05 | 4.29E-06 | 1.82E-06 | 3.95E-06 | 4.80E-05 | No Data  | 5.79E-05 |
| Te-129  | 3.14E-08 | 1.18E-08 | 7.65E-09 | 2.41E-08 | 1.32E-07 | No Data  | 2.37E-08 |
| Te-131m | 1.73E-06 | 8.46E-07 | 7.05E-07 | 1.34E-06 | 8.57E-06 | No Data  | 8.40E-05 |
| Te-131  | 1.97E-08 | 8.23E-09 | 6.22E-09 | 1.62E-08 | 8.63E-08 | No Data  | 2.79E-09 |

Table 2-7 (contd). Adult Ingestion Dose Factors

| Nuclide | Bone     | Liver    | T.Body   | Thyroid  | Kidney   | Lung     | GI-LLI   |
|---------|----------|----------|----------|----------|----------|----------|----------|
| Te-132  | 2.52E-06 | 1.63E-06 | 1.53E-06 | 1.80E-06 | 1.57E-05 | No Data  | 7.71E-05 |
| I-130   | 7.56E-07 | 2.23E-06 | 8.80E-07 | 1.89E-04 | 3.48E-06 | No Data  | 1.92E-06 |
| I-131   | 4.16E-06 | 5.95E-06 | 3.41E-06 | 1.95E-03 | 1.02E-05 | No Data  | 1.57E-06 |
| I-132   | 2.03E-07 | 5.43E-07 | 1.90E-07 | 1.90E-05 | 8.65E-07 | No Data  | 1.02E-07 |
| I-133   | 1.42E-06 | 2.47E-06 | 7.53E-07 | 3.63E-04 | 4.31E-06 | No Data  | 2.22E-06 |
| I-134   | 1.06E-07 | 2.88E-07 | 1.03E-07 | 4.99E-06 | 4.58E-07 | No Data  | 2.51E-10 |
| I-135   | 4.43E-07 | 1.16E-06 | 4.28E-07 | 7.65E-05 | 1.86E-06 | No Data  | 1.31E-06 |
| Cs-134  | 6.22E-05 | 1.48E-04 | 1.21E-04 | No Data  | 4.79E-05 | 1.59E-05 | 2.59E-06 |
| Cs-136  | 6.51E-06 | 2.57E-05 | 1.85E-05 | No Data  | 1.43E-05 | 1.96E-06 | 2.92E-06 |
| Cs-137  | 7.97E-05 | 1.09E-04 | 7.14E-05 | No Data  | 3.70E-05 | 1.23E-05 | 2.11E-06 |
| Cs-138  | 5.52E-08 | 1.09E-07 | 5.40E-08 | No Data  | 8.01E-08 | 7.91E-09 | 4.65E-13 |
| Ba-139  | 9.70E-08 | 6.91E-11 | 2.84E-09 | No Data  | 6.46E-11 | 3.92E-11 | 1.72E-07 |
| Ba-140  | 2.03E-05 | 2.55E-08 | 1.33E-06 | No Data  | 8.67E-09 | 1.46E-08 | 4.18E-05 |
| Ba-141  | 4.71E-08 | 3.56E-11 | 1.59E-09 | No Data  | 3.31E-11 | 2.02E-11 | 2.22E-17 |
| Ba-142  | 2.13E-08 | 2.19E-11 | 1.34E-09 | No Data  | 1.85E-11 | 1.24E-11 | 3.00E-26 |
| La-140  | 2.50E-09 | 1.26E-09 | 3.33E-10 | No Data  | No Data  | No Data  | 9.25E-05 |
| La-142  | 1.28E-10 | 5.82E-11 | 1.45E-11 | No Data  | No Data  | No Data  | 4.25E-07 |
| Ce-141  | 9.36E-09 | 6.33E-09 | 7.18E-10 | No Data  | 2.94E-09 | No Data  | 2.42E-05 |
| Ce-143  | 1.65E-09 | 1.22E-06 | 1.35E-10 | No Data  | 5.37E-10 | No Data  | 4.56E-05 |
| Ce-144  | 4.88E-07 | 2.04E-07 | 2.62E-08 | No Data  | 1.21E-07 | No Data  | 1.65E-04 |
| Pr-143  | 9.20E-09 | 3.69E-09 | 4.56E-10 | No Data  | 2.13E-09 | No Data  | 4.03E-05 |
| Pr-144  | 3.01E-11 | 1.25E-11 | 1.53E-12 | No Data  | 7.05E-12 | No Data  | 4.33E-18 |
| Nd-147  | 6.29E-09 | 7.27E-09 | 4.35E-10 | No Data  | 4.25E-09 | No Data  | 3.49E-05 |
| W-187   | 1.03E-07 | 8.61E-08 | 3.01E-08 | No Data  | No Data  | No Data  | 2.82E-05 |
| Np-239  | 1.19E-09 | 1.17E-10 | 6.45E-11 | No Data  | 3.65E-10 | No Data  | 2.40E-05 |

Table 2-8. Site-Related Ingestion Dose Factors,  $A_{it}$ 

| Nuclide | Bone     | Liver    | T. Body  | Thyroid  | Kidney   | Lung     | GI-LLI   |
|---------|----------|----------|----------|----------|----------|----------|----------|
| H-3     | 0.00     | 1.32E+00 | 1.32E+00 | 1.32E+00 | 1.32E+00 | 1.32E+00 | 1.32E+00 |
| C-14    | 3.13E+04 | 6.26E+03 | 6.26E+03 | 6.26E+03 | 6.26E+03 | 6.26E+03 | 6.26E+03 |
| Na-24   | 1.36E+02 | 1.36E+02 | 1.36E+02 | 1.36E+02 | 1.36E+02 | 1.36E+02 | 1.36E+02 |
| P-32    | 1.32E+06 | 8.22E+04 | 5.11E+04 | 0.00     | 0.00     | 0.00     | 1.49E+05 |
| Cr-51   | 0.00     | 0.00     | 1.27E+00 | 7.58E-01 | 2.79E-01 | 1.68E+00 | 3.19E+02 |
| Mn-54   | 0.00     | 4.41E+03 | 8.42E+02 | 0.00     | 1.31E+03 | 0.00     | 1.35E+04 |
| Mn-56   | 0.00     | 1.74E-01 | 3.08E-02 | 0.00     | 2.21E-01 | 0.00     | 5.55E+00 |
| Fe-55   | 6.86E+02 | 4.74E+02 | 1.11E+02 | 0.00     | 0.00     | 2.65E+02 | 2.72E+02 |
| Fe-59   | 1.07E+03 | 2.51E+03 | 9.61E+02 | 0.00     | 0.00     | 7.01E+02 | 8.36E+03 |
| Co-58   | 0.00     | 9.59E+01 | 2.15E+02 | 0.00     | 0.00     | 0.00     | 1.94E+03 |
| Co-60   | 0.00     | 2.78E+02 | 6.14E+02 | 0.00     | 0.00     | 0.00     | 5.23E+03 |
| Ni-63   | 3.25E+04 | 2.25E+03 | 1.09E+03 | 0.00     | 0.00     | 0.00     | 4.70E+02 |
| Ni-65   | 1.72E-01 | 2.23E-02 | 1.02E-02 | 0.00     | 0.00     | 0.00     | 5.66E-01 |
| Cu-64   | 0.00     | 2.75E+00 | 1.29E+00 | 0.00     | 6.94E+00 | 0.00     | 2.35E+02 |
| Zn-65   | 2.32E+04 | 7.37E+04 | 3.33E+04 | 0.00     | 4.93E+04 | 0.00     | 4.64E+04 |
| Zn-69   | 7.88E-07 | 1.51E-06 | 1.05E-07 | 0.00     | 9.79E-07 | 0.00     | 2.26E-07 |
| Br-83   | 0.00     | 0.00     | 3.83E-02 | 0.00     | 0.00     | 0.00     | 5.52E-02 |
| Br-84   | 0.00     | 0.00     | 1.22E-12 | 0.00     | 0.00     | 0.00     | 9.61E-18 |
| Br-85   | 0.00     | 0.00     | 0.00     | 0.00     | 0.00     | 0.00     | 0.00     |
| Rb-86   | 0.00     | 9.75E+04 | 4.54E+04 | 0.00     | 0.00     | 0.00     | 1.92E+04 |
| Rb-88   | 0.00     | 1.29E-22 | 6.82E-23 | 0.00     | 0.00     | 0.00     | 1.78E-33 |
| Rb-89   | 0.00     | 1.61E-26 | 1.14E-26 | 0.00     | 0.00     | 0.00     | 0.00     |
| Sr-89   | 2.49E+04 | 0.00     | 7.16E+02 | 0.00     | 0.00     | 0.00     | 4.00E+03 |
| Sr-90   | 6.23E+05 | 0.00     | 1.53E+05 | 0.00     | 0.00     | 0.00     | 1.80E+04 |
| Sr-91   | 7.25E+01 | 0.00     | 2.93E+00 | 0.00     | 0.00     | 0.00     | 3.45E+02 |
| Sr-92   | 3.33E-01 | 0.00     | 1.44E-02 | 0.00     | 0.00     | 0.00     | 6.60E+00 |
| Y-90    | 5.04E-01 | 0.00     | 1.35E-02 | 0.00     | 0.00     | 0.00     | 5.34E+03 |
| Y-91m   | 1.04E-11 | 0.00     | 4.01E-13 | 0.00     | 0.00     | 0.00     | 3.04E-11 |
| Y-91    | 9.77E+00 | 0.00     | 2.61E-01 | 0.00     | 0.00     | 0.00     | 5.38E+03 |
| Y-92    | 4.61E-04 | 0.00     | 1.35E-05 | 0.00     | 0.00     | 0.00     | 8.07E+00 |
| Y-93    | 3.19E-02 | 0.00     | 8.82E-04 | 0.00     | 0.00     | 0.00     | 1.01E+03 |
| Zr-95   | 5.47E-01 | 1.75E-01 | 1.19E-01 | 0.00     | 2.75E-01 | 0.00     | 5.56E+02 |
| Zr-97   | 7.40E-03 | 1.49E-03 | 6.83E-04 | 0.00     | 2.26E-03 | 0.00     | 4.62E+02 |
| Nb-95   | 8.09E+00 | 4.50E+00 | 2.42E+00 | 0.00     | 4.45E+00 | 0.00     | 2.73E+04 |
| Mo-99   | 0.00     | 1.07E+02 | 2.04E+01 | 0.00     | 2.43E+02 | 0.00     | 2.49E+02 |
| Tc-99m  | 5.70E-04 | 1.61E-03 | 2.05E-02 | 0.00     | 2.44E-02 | 7.89E-04 | 9.53E-01 |

All values are in (mrem·mL)/(h· $\mu$ Ci). They are calculated using equation (2.14), and data from Table 2-5, Table 2-6, and Table 2-7. When "No Data" is shown for a radionuclide-organ combination in Table 2-7,  $A_{it}$  factors in this table are presented as zero.

Table 2-8 (contd). Site-Related Ingestion Dose Factors,  $A_{ir}$ 

| Nuclide | Bone     | Liver    | T. Body  | Thyroid  | Kidney   | Lung     | GI-LLI   |
|---------|----------|----------|----------|----------|----------|----------|----------|
| Tc-101  | 2.71E-33 | 3.91E-33 | 3.83E-32 | 0.00     | 7.03E-32 | 2.00E-33 | 0.00     |
| Ru-103  | 6.21E+00 | 0.00     | 2.68E+00 | 0.00     | 2.37E+01 | 0.00     | 7.25E+02 |
| Ru-105  | 8.79E-03 | 0.00     | 3.47E-03 | 0.00     | 1.14E-01 | 0.00     | 5.38E+00 |
| Ru-106  | 9.42E+01 | 0.00     | 1.19E+01 | 0.00     | 1.82E+02 | 0.00     | 6.10E+03 |
| Rh-105  | 2.32E+00 | 1.69E+00 | 1.11E+00 | 0.00     | 7.15E+00 | 0.00     | 2.68E+02 |
| Ag-110m | 2.53E+00 | 2.34E+00 | 1.39E+00 | 0.00     | 4.61E+00 | 0.00     | 9.56E+02 |
| Sb-124  | 1.36E+03 | 2.56E+01 | 5.37E+02 | 3.28E+00 | 0.00     | 1.05E+03 | 3.84E+04 |
| Sb-125  | 1.09E+03 | 1.17E+01 | 2.19E+02 | 9.68E-01 | 0.00     | 1.14E+05 | 9.63E+03 |
| Te-125m | 2.56E+03 | 9.29E+02 | 3.43E+02 | 7.71E+02 | 1.04E+04 | 0.00     | 1.02E+04 |
| Te-127m | 6.51E+03 | 2.33E+03 | 7.93E+02 | 1.66E+03 | 2.64E+04 | 0.00     | 2.18E+04 |
| Te-127  | 1.78E+01 | 6.40E+00 | 3.85E+00 | 1.32E+01 | 7.25E+01 | 0.00     | 1.41E+03 |
| Te-129m | 1.09E+04 | 4.07E+03 | 1.73E+03 | 3.74E+03 | 4.55E+04 | 0.00     | 5.49E+04 |
| Te-129  | 1.78E-05 | 6.68E-06 | 4.33E-06 | 1.36E-05 | 7.47E-05 | 0.00     | 1.34E-05 |
| Te-131m | 9.57E+02 | 4.68E+02 | 3.90E+02 | 7.42E+02 | 4.74E+03 | 0.00     | 4.65E+04 |
| Te-131  | 8.64E-17 | 3.61E-17 | 2.73E-17 | 7.10E-17 | 3.78E-16 | 0.00     | 1.22E-17 |
| Te-132  | 1.97E+03 | 1.27E+03 | 1.19E+03 | 1.41E+03 | 1.23E+04 | 0.00     | 6.02E+04 |
| I-130   | 7.60E+00 | 2.24E+01 | 8.85E+00 | 1.90E+03 | 3.50E+01 | 0.00     | 1.93E+01 |
| I-131   | 1.73E+02 | 2.48E+02 | 1.42E+02 | 8.13E+04 | 4.25E+02 | 0.00     | 6.55E+01 |
| I-132   | 5.27E-03 | 1.41E-02 | 4.93E-03 | 4.93E-01 | 2.24E-02 | 0.00     | 2.65E-03 |
| I-133   | 2.59E+01 | 4.51E+01 | 1.37E+01 | 6.62E+03 | 7.86E+01 | 0.00     | 4.05E+01 |
| I-134   | 2.18E-08 | 5.94E-08 | 2.12E-08 | 1.03E-06 | 9.44E-08 | 0.00     | 5.17E-11 |
| I-135   | 1.31E+00 | 3.44E+00 | 1.27E+00 | 2.27E+02 | 5.52E+00 | 0.00     | 3.89E+00 |
| Cs-134  | 2.98E+05 | 7.10E+05 | 5.80E+05 | 0.00     | 2.30E+05 | 7.62E+04 | 1.24E+04 |
| Cs-136  | 2.96E+04 | 1.17E+05 | 8.42E+04 | 0.00     | 6.51E+04 | 8.92E+03 | 1.33E+04 |
| Cs-137  | 3.82E+05 | 5.23E+05 | 3.43E+05 | 0.00     | 1.78E+05 | 5.90E+04 | 1.01E+04 |
| Cs-138  | 9.12E-12 | 1.80E-11 | 8.92E-12 | 0.00     | 1.32E-11 | 1.31E-12 | 7.68E-17 |
| Ba-139  | 5.64E-06 | 4.02E-09 | 1.65E-07 | 0.00     | 3.76E-09 | 2.28E-09 | 1.00E-05 |
| Ba-140  | 3.74E+02 | 4.69E-01 | 2.45E+01 | 0.00     | 1.60E-01 | 2.69E-01 | 7.69E+02 |
| Ba-141  | 8.47E-25 | 6.40E-28 | 2.86E-26 | 0.00     | 5.95E-28 | 3.63E-28 | 3.99E-34 |
| Ba-142  | 0.00     | 0.00     | 0.00     | 0.00     | 0.00     | 0.00     | 0.00     |
| La-140  | 1.10E-01 | 5.56E-02 | 1.47E-02 | 0.00     | 0.00     | 0.00     | 4.08E+03 |
| La-142  | 2.19E-07 | 9.96E-08 | 2.48E-08 | 0.00     | 0.00     | 0.00     | 7.27E-04 |
| Ce-141  | 1.15E-01 | 7.79E-02 | 8.84E-03 | 0.00     | 3.62E-02 | 0.00     | 2.98E+02 |
| Ce-143  | 8.65E-03 | 6.39E+00 | 7.08E-04 | 0.00     | 2.81E-03 | 0.00     | 2.39E+02 |
| Ce-144  | 6.22E+00 | 2.60E+00 | 3.34E-01 | 0.00     | 1.54E+00 | 0.00     | 2.10E+03 |
| Pr-143  | 6.10E-01 | 2.44E-01 | 3.02E-02 | 0.00     | 1.41E-01 | 0.00     | 2.67E+03 |
| Pr-144  | 1.48E-28 | 6.14E-29 | 7.51E-30 | 0.00     | 3.46E-29 | 0.00     | 2.13E-35 |
| Nd-147  | 4.11E-01 | 4.75E-01 | 2.84E-02 | 0.00     | 2.78E-01 | 0.00     | 2.28E+03 |
| W-187   | 1.47E+02 | 1.23E+02 | 4.31E+01 | 0.00     | 0.00     | 0.00     | 4.04E+04 |
| Np-239  | 2.81E-02 | 2.76E-03 | 1.52E-03 | 0.00     | 8.62E-03 | 0.00     | 5.67E+02 |

## 2.5 LIQUID EFFLUENT DOSE PROJECTIONS

### 2.5.1 Thirty-One Day Dose Projections

In order to meet the requirements for operation of the LIQUID RADWASTE TREATMENT SYSTEM (see Section 2.1.4), dose projections must be made at least once each 31 days; this applies during periods in which a discharge to UNRESTRICTED AREAS of liquid effluents containing radioactive materials occurs or is expected.

Projected 31-day doses to individuals due to liquid effluents may be determined as follows:

$$D_{\tau p} = \left( \frac{D_{\tau c}}{t} \right) \times 31 + D_{\tau a} \quad (2.17)$$

where:

- $D_{\tau p}$  = the projected dose to the total body or organ  $\tau$ , for the next 31 days of liquid releases.
- $D_{\tau c}$  = the cumulative dose to the total body or organ  $\tau$ , for liquid releases that have occurred in the elapsed portion of the current quarter, plus the release under consideration.
- $t$  = the number of whole or partial days elapsed into the current quarter, including the time to the end of the release under consideration (even if the release continues into the next quarter).
- $D_{\tau a}$  = the anticipated dose contribution to the total body or any organ  $\tau$ , due to any planned activities during the next 31-day period, if those activities will result in liquid releases that are in addition to routine liquid effluents. If only routine liquid effluents are anticipated,  $D_{\tau a}$  may be set to zero.

### 2.5.2 Dose Projections for Specific Releases

Dose projections may be performed for a particular release by performing a prerelease dose calculation assuming that the planned release will proceed as anticipated. For individual dose projections due to liquid releases, follow the methodology of Section 2.4, using sample analysis results for the source to be released, and parameter values expected to exist during the release period.

## 2.6 DEFINITIONS OF LIQUID EFFLUENT TERMS

The following symbolic terms are used in the presentation of liquid effluent calculations in the subsections above.

| <u>Term</u>   | <u>Definition</u>   | <u>Section of Initial Use</u> |
|---------------|---|-------------------------------|
| $A_p =$       | the adjustment factor used in calculating the effluent monitor setpoint for liquid release pathway p: the ratio of the assured dilution to the required dilution [unitless].  | 2.3.2.2                       |
| $ADF =$       | the assured dilution factor for a planned release [unitless].   | 2.3.2.2                       |
| $AF_p =$      | the dilution allocation factor for liquid release pathway p [unitless].   | 2.3.2.2                       |
| $A_{i\tau} =$ | the site-related adult ingestion dose commitment factor, for the total body or for any organ $\tau$ , due to identified radionuclide i [(mrem · mL)/(h · $\mu$ Ci)]. The values of $A_{i\tau}$ are listed in Table 2-8. | 2.4.1                         |
| $B_{iv} =$    | the crop to soil concentration factor applicable to radionuclide i, [(pCi/kg garden vegetation)/(pCi/kg soil)].   | 2.4.3                         |
| $BF_i =$      | the bioaccumulation factor for radionuclide i for freshwater fish [(pCi/kg)/(pCi/L)]. Values are listed in Table 2-6.   | 2.4.2                         |
| $c =$         | the setpoint of the radioactivity monitor measuring the concentration of radioactivity in the effluent line, prior to dilution and subsequent release [ $\mu$ Ci/mL].   | 2.3.2.1                       |
| $C_p =$       | the calculated effluent radioactivity monitor setpoint for liquid release pathway p [ $\mu$ Ci/mL].   | 2.3.2.2                       |
| $C_a =$       | the gross concentration of alpha emitters in the liquid waste as measured in the applicable composite sample [ $\mu$ Ci/mL].  | 2.3.2.2                       |
| $C_{ECL} =$   | the Effluent Concentration Limit stated in 10 CFR 20, Appendix B, Table 2, Column 2 [ $\mu$ Ci/mL].   | 2.3.2.1                       |
| $C_f =$       | the concentration of Fe-55 in the liquid waste as measured in the applicable composite sample [ $\mu$ Ci/mL].   | 2.3.2.2                       |

| <u>Term</u>    | <u>Definition</u>  | <u>Section of Initial Use</u> |
|----------------|--|-------------------------------|
| $C_g =$        | the concentration of gamma emitter $g$ in the liquid waste as measured by gamma ray spectroscopy performed on the applicable prerelease waste sample [ $\mu\text{Ci/mL}$ ].                | 2.3.2.2                       |
| $C_i =$        | the measured concentration of radionuclide $i$ in a sample of liquid effluent [ $\mu\text{Ci/mL}$ ].   | 2.3.2.2                       |
| $C_{ij} =$     | the average concentration of radionuclide $i$ in undiluted liquid effluent during time period $j$ [ $\mu\text{Ci/mL}$ ].   | 2.4.1                         |
| $C_{ir} =$     | the measured concentration of radionuclide $i$ in release pathway $r$ that is contributing to radioactivity in the dilution stream [ $\mu\text{Ci/mL}$ ].                                  | 2.3.2.2                       |
| $C_s =$        | the concentration of strontium radioisotope $s$ (Sr-89 or Sr-90) in the liquid waste as measured in the applicable composite sample [ $\mu\text{Ci/mL}$ ].                                 | 2.3.2.2                       |
| $C_t =$        | the concentration of H-3 in the liquid waste as measured in the applicable composite sample [ $\mu\text{Ci/mL}$ ].   | 2.3.2.2                       |
| $CF_{iv} =$    | the concentration factor for radionuclide $i$ in irrigated garden vegetation [ $(p\text{Ci/kg})/(p\text{Ci/L})$ ].   | 2.4.2                         |
| $D_w =$        | the dilution factor from the near field of the discharge structure to the potable water intake location [unitless].  | 2.4.2                         |
| $D_\tau =$     | the cumulative dose commitment to the total body or to any organ $\tau$ , due to radioactivity in liquid effluents released during a given time period [mrem].                             | 2.4.1                         |
| $D_{\tau a} =$ | the anticipated dose contribution to the total body or any organ $\tau$ , due to any planned activities during the next 31-day period [mrem].  | 2.5.1                         |
| $D_{\tau c} =$ | the cumulative dose to the total body or organ $\tau$ , for liquid releases that have occurred in the elapsed portion of the current quarter, plus the release under consideration [mrem]. | 2.5.1                         |
| $D_{\tau p} =$ | the projected dose to the total body or organ $\tau$ , for the next 31 days of liquid releases [mrem].   | 2.5.1                         |

| <u>Term</u>    | <u>Definition</u>   | <u>Section of Initial Use</u> |
|----------------|---|-------------------------------|
| $DF_{i\tau}$ = | the dose conversion factor for radionuclide $i$ for adults, in organ $\tau$ [mrem/pCi]. Values are listed in Table 2-7.         | 2.4.2                         |
| $ECL_i$ =      | the liquid Effluent Concentration Limit for radionuclide $i$ from 10 CFR Part 20, Appendix B, Table 2, Column 2 [ $\mu$ Ci/mL]. | 2.3.2.2                       |
| $f$ =          | the effluent flowrate at the location of the radioactivity monitor [gpm].   | 2.3.2.1                       |
| $f_{ap}$ =     | the anticipated actual discharge flowrate for a planned release from liquid release pathway $p$ [gpm].                          | 2.3.2.2                       |
| $f_l$ =        | the fraction of the year that garden vegetation is irrigated [unitless].  | 2.4.3                         |
| $f_{mp}$ =     | the maximum permissible effluent discharge flowrate for release pathway $p$ [gpm].  | 2.3.2.2                       |
| $f_r$ =        | the effluent discharge flowrate of release pathway $r$ [gpm].   | 2.3.2.2                       |
| $f_t$ =        | the average undiluted liquid waste flowrate actually observed during the period of a liquid release [gpm].                      | 2.4.1                         |
| $F$ =          | the dilution stream flowrate which can be assured prior to the release point to the UNRESTRICTED AREA [gpm].                    | 2.3.2.1                       |
| $F_d$ =        | the entire assured dilution flowrate for the plant site during the release period [gpm].  | 2.3.2.2                       |
| $F_{dp}$ =     | the dilution flowrate allocated to release pathway $p$ [gpm].   | 2.3.2.2                       |
| $F_l$ =        | the near-field average dilution factor in the receiving water of the UNRESTRICTED AREA [unitless].                              | 2.4.1                         |
| $F_t$ =        | the average dilution stream flowrate actually observed during the period of a liquid release [gpm].                             | 2.4.1                         |
| $I$ =          | the average irrigation rate during the growing season [ $L/(m^2 \cdot h)$ ].  | 2.4.3                         |
| $L_v$ =        | the water content of leafy garden vegetation edible parts [L/kg].   | 2.4.3                         |

| <u>Term</u>         | <u>Definition</u>  | <u>Section of Initial Use</u> |
|---------------------|--|-------------------------------|
| M =                 | the additional river dilution factor from the near field of the discharge structure for the plant site to the point of irrigation water usage [unitless].  | 2.4.3                         |
| P =                 | the effective surface density of soil [kg/m <sup>2</sup> ].  | 2.4.3                         |
| r =                 | the fraction of irrigation-deposited activity retained on the edible portions of leafy garden vegetation.  | 2.4.3                         |
| RDF =               | the required dilution factor: the minimum ratio by which liquid effluent must be diluted before reaching the UNRESTRICTED AREA, in order to ensure that the limits of Section 2.1.2 are not exceeded [unitless]. | 2.3.2.2                       |
| RDF <sub>γ</sub> =  | the RDF for a liquid release due only to its concentration of gamma-emitting radionuclides [unitless].   | 2.3.2.2                       |
| RDF <sub>nγ</sub> = | the RDF for a liquid release due only to its concentration of non-gamma-emitting radionuclides [unitless].   | 2.3.2.2                       |
| SF =                | the safety factor selected to compensate for statistical fluctuations and errors of measurement [unitless].  | 2.3.2.2                       |
| t =                 | the number of whole or partial days elapsed into the current quarter, including the time to the end of the release under consideration.  | 2.5.1                         |
| t <sub>b</sub> =    | the period of long-term buildup of activity in soil [h].   | 2.4.3                         |
| t <sub>e</sub> =    | the period of leafy garden vegetation exposure during the growing season [h].  | 2.4.3                         |
| t <sub>f</sub> =    | the transit time from release to receptor for fish consumption [h].  | 2.4.2                         |
| t <sub>h</sub> =    | the time between harvest of garden vegetation and human consumption [h].   | 2.4.3                         |
| t <sub>w</sub> =    | the transit time from release to receptor for potable water consumption [h].   | 2.4.2                         |

| <u>Term</u>      | <u>Definition</u>   | <u>Section of Initial Use</u> |
|------------------|---|-------------------------------|
| TF =             | the tolerance factor selected to allow flexibility in the establishment of a practical monitor setpoint which could accommodate effluent releases at concentrations higher than the ECL values stated in 10 CFR 20, Appendix B, Table 2, Column 2 [unitless]; the tolerance factor must not exceed a value of 10. | 2.3.2.1                       |
| $U_f$ =          | the adult rate of fish consumption [kg/y].  | 2.4.2                         |
| $U_v$ =          | the adult consumption rate for irrigated garden vegetation [kg/y].  | 2.4.2                         |
| $U_w$ =          | the adult drinking water consumption rate applicable to the plant site [L/y].   | 2.4.2                         |
| $Y_v$ =          | the areal density (agricultural productivity) of leafy garden vegetation [kg/m <sup>2</sup> ].  | 2.4.3                         |
| Z =              | the applicable dilution factor for the receiving water body, in the near field of the discharge structure, during the period of radioactivity release [unitless].   | 2.4.1                         |
| $\Delta t_1$ =   | the length of time period 1, over which $C_{i1}$ and $F_1$ are averaged for liquid releases [h].  | 2.4.1                         |
| $\lambda_{Ei}$ = | the effective removal rate for activity deposited on crop leaves [h <sup>-1</sup> ].  | 2.4.3                         |
| $\lambda_i$ =    | the decay constant for radionuclide i [h <sup>-1</sup> ].   | 2.4.2                         |
| $\lambda_w$ =    | the rate constant for removal of activity from plant leaves by weathering [h <sup>-1</sup> ].   | 2.4.3                         |

---

CHAPTER 3  
GASEOUS EFFLUENTS

### 3.1 LIMITS OF OPERATION

The following Limits of Operation implement requirements established by Technical Specifications Section 5.0. Terms printed in all capital letters are defined in Chapter 10.

#### 3.1.1 Gaseous Effluent Monitoring Instrumentation Control

In accordance with Technical Specification 5.5.4.a, the radioactive gaseous effluent monitoring instrumentation channels shown in Table 3-1 shall be FUNCTIONAL with their alarm/trip setpoints set to ensure that the limits of Section 3.1.2.a are not exceeded. The alarm/trip setpoints of these channels shall be determined in accordance with Section 3.3.

##### 3.1.1.1 Applicability

These limits apply as shown in Table 3-1.

##### 3.1.1.2 Actions

With a radioactive gaseous effluent monitoring instrumentation channel alarm/trip setpoint less conservative than required by the above control, immediately suspend the release of radioactive gaseous effluents monitored by the affected channel, declare the channel NON-FUNCTIONAL, or restore the setpoint to a value that will ensure that the limits of Section 3.1.2.a are met.

With less than the minimum number of radioactive gaseous effluent monitoring instrumentation channels FUNCTIONAL, take the ACTION shown in Table 3-1. Restore the NON-FUNCTIONAL instrumentation to FUNCTIONAL status within 30 days, or if unsuccessful, explain in the next Radioactive Effluent Release Report, per Technical Specification 5.6.3, why this NON-FUNCTIONALITY was not corrected in a timely manner.

This control does not affect shutdown requirements or MODE changes.

##### 3.1.1.3 Surveillance Requirements

Each radioactive gaseous effluent monitoring instrumentation channel shall be demonstrated FUNCTIONAL by performance of the CHANNEL CHECK, SOURCE CHECK, CHANNEL CALIBRATION and CHANNEL FUNCTIONAL TEST operations at the frequencies shown in Table 3-2.

---

#### 3.1.1.4 Basis

The radioactive gaseous effluent instrumentation is provided to monitor and control, as applicable, the releases of radioactive materials in gaseous effluents during actual or potential releases of gaseous effluents. The Alarm/Trip Setpoints for these instruments shall be calculated and adjusted in accordance with the methodology and parameters in Section 3.3 to ensure that the alarm/trip will occur prior to exceeding the limits of Section 3.1.2.a. The FUNCTIONALITY and use of this instrumentation is consistent with the requirements of General Design Criteria 60, 63, and 64 of Appendix A to 10 CFR Part 50.

Table 3-1. Radioactive Gaseous Effluent Monitoring Instrumentation

| Instrument  | FUNCTIONALITY Requirements  |                              |        |
|---|-----------------------------|------------------------------|--------|
|   | Minimum Channels FUNCTIONAL | Applicability                | ACTION |
| <b>1. GASEOUS RADWASTE TREATMENT SYSTEM (Common)</b>                                      |                             |                              |        |
| a. Noble Gas Activity Monitor, with Alarm and Automatic Termination of Release (ARE-0014) | 1                           | During releases <sup>a</sup> | 45     |
| b. Effluent System Flowrate Measuring Device (AFT-0014)                                   | 1                           | During releases <sup>a</sup> | 46     |
| <b>2. Turbine Building Vent (Each Unit)</b>   |                             |                              |        |
| a. Noble Gas Activity Monitor (RE-12839C)   | 1                           | During releases <sup>a</sup> | 47     |
| b. Iodine and Particulate Samplers (RE-12839A & B)  | 1                           | During releases <sup>a</sup> | 51     |
| c. Flowrate Monitor (FT-12839 or FIS-12862) <sup>b</sup>                                  | 1                           | During releases <sup>a</sup> | 46     |
| d. Sampler Flowrate Monitor (1FIT-13211, 2FIT-13211)                                      | 1                           | During releases <sup>a</sup> | 46     |
| <b>3. Plant Vent (Each Unit)</b>  |                             |                              |        |
| a. Noble Gas Activity Monitor (RE-12442C or RE-12444C)                                    | 1                           | At all times                 | 47,48  |
| b. Iodine Sampler/Monitor (RE-12442B or RE-12444B)  | 1                           | At all times                 | 51     |
| c. Particulate Sampler/Monitor (RE-12442A or RE-12444A)                                   | 1                           | At all times                 | 51     |
| d. Flowrate Monitor (FT-12442 or 12835)   | 1                           | At all times                 | 46     |
| e. Sampler Flowrate Monitor (FI-12442 or FI-12444N)                                       | 1                           | At all times                 | 46     |
| <b>4. Radwaste Processing Facility Vent (Common)</b>                                      |                             |                              |        |
| a. Particulate Monitor (ARE-16980)  | 1                           | During releases <sup>a</sup> | 51     |

a. "During releases" means "During radioactive releases via this pathway."

b. During emergency filtration.

---

Table 3-1 (contd).                      Notation for Table 3-1 — ACTION Statements

---

ACTION 45 — With the number of channels FUNCTIONAL less than required by the Minimum Channels FUNCTIONAL requirement, the contents of the tank(s) may be released to the environment for up to 14 days provided that prior to initiating the release:

- a.        The local radiation monitor reading (if functional) is recorded at least once per 12 hours or at least two independent samples of the tank's contents are analyzed, and
- b.        At least two technically qualified members of the Facility Staff independently verify the discharge line valving, and verify the release rate calculations.

Otherwise, suspend release of radioactive effluents via this pathway.

ACTION 46 — With the number of channels FUNCTIONAL less than required by the Minimum Channels FUNCTIONAL requirement, effluent releases via this pathway may continue provided the flowrate is estimated at least once per 4 hours.

ACTION 47 — With the number of channels FUNCTIONAL less than required by the Minimum Channels FUNCTIONAL requirement, effluent releases via this pathway may continue provided the local radiation monitor reading (if functional) is recorded at least once per 12 hours or grab samples are taken at least once per 12 hours and these samples are analyzed for radioactivity within 24 hours. With the plant vent radiation monitor iodine and particulate channels NON-FUNCTIONAL during the loss of sample line heat tracing, the noble gas channel of RE-12442 and RE-12444 would still be considered valid.

ACTION 48 — With the number of channels FUNCTIONAL less than required by the Minimum Channels FUNCTIONAL requirement, record the local radiation monitor reading (if functional) for RE-2565C at least once per 12 hours or immediately suspend containment purging of radioactive effluents via this pathway.

ACTION 49 — (Not Used)

ACTION 50 — (Not Used)

ACTION 51 — With the number of channels FUNCTIONAL less than required by the Minimum Channels FUNCTIONAL requirement, effluent releases via the affected pathway may continue provided one of the following options is available (1) the local radiation monitor reading (if functional) is recorded at least once per 12 hours (2) samples are continuously collected with the installed skid or (3) samples are continuously collected with auxiliary sampling equipment. RE-12444A and B may be verified functional by recording local radiation monitor skid flow once per 12 hours. With the plant vent radiation monitor particulate and iodine channels NON-FUNCTIONAL during the loss of sample line heat tracing, estimate radioactive releases for up to 48 hours while continuing to monitor noble gas activity from RE-12442 and RE-12444.

Table 3-2. Radioactive Gaseous Effluent Monitoring Instrumentation Surveillance Requirements

| Instrument  | Surveillance Requirements |              |                     |                         |                    |
|---|---------------------------|--------------|---------------------|-------------------------|--------------------|
|   | CHANNEL CHECK             | SOURCE CHECK | CHANNEL CALIBRATION | CHANNEL FUNCTIONAL TEST | MODES <sup>c</sup> |
| <b>1. GASEOUS RADWASTE TREATMENT SYSTEM (Common)</b>                                      |                           |              |                     |                         |                    |
| a. Noble Gas Activity Monitor, with Alarm and Automatic Termination of Release (ARE-0014) | P                         | P            | R <sup>b</sup>      | R <sup>a(1)</sup>       | During Release     |
| b. Effluent System Flowrate Measuring Device (AFT-0014)                                   | P                         | NA           | R                   | NA                      | During Release     |
| <b>2. Turbine Building Vent (Each Unit)</b>   |                           |              |                     |                         |                    |
| a. Noble Gas Activity Monitor (RE-12839C)   | M                         | SA           | R <sup>b</sup>      | R <sup>a(2)</sup>       | During Release     |
| b. Iodine and Particulate Samplers (RE-12839A&B)  | M <sup>d</sup>            | NA           | NA                  | NA                      | During Release     |
| c. Flowrate Monitor (FT-12839 or FIS-12862)   | M                         | NA           | R                   | NA                      | During Release     |
| d. Sampler Flowrate Monitor (1FIT-13211, 2FIT-13211)                                      | M                         | NA           | R                   | Q                       | During Release     |
| <b>3. Plant Vent (Each Unit)</b>  |                           |              |                     |                         |                    |
| a. Noble Gas Activity Monitor (RE-12442C or RE-12444C)                                    | M                         | SA           | R <sup>b</sup>      | R <sup>a(2)</sup>       | All                |
| b. Particulate and Iodine Monitors (RE-12442A&B)  | M <sup>d</sup>            | NA           | R                   | R <sup>a(2)</sup>       | All                |
| c. Particulate and Iodine Samplers (RE-12444A&B)  | M <sup>d</sup>            | NA           | NA                  | NA                      | All                |
| d. Flowrate Monitor (FT-12442 or 12835)   | M                         | NA           | R                   | NA                      | All                |
| e. Sampler Flowrate Monitor (FI-12442 or FI-12444N)                                       | M                         | NA           | R                   | Q                       | All                |
| <b>4. Radwaste Processing Facility Vent (Common)</b>                                      |                           |              |                     |                         |                    |
| a. Particulate Monitor (ARE-16980)  | M <sup>d</sup>            | SA           | R <sup>e</sup>      | N/A                     | During Release     |

Table 3-2 (contd). Notation for Table 3-2

- 
- a. In addition to the basic functions of a CHANNEL FUNCTIONAL TEST (Section 10.2):
- (1) The CHANNEL FUNCTIONAL TEST shall also demonstrate that automatic isolation of this pathway and control room annunciation occurs (for item a. below only); and control room CRT indication occurs (if any of the following conditions exist):
    - (a) Instrument indicates measured levels above the alarm/trip setpoint;
    - (b) Instrument indicates an "Equipment Trouble" alarm;
    - (c) Instrument indicates a "Low" alarm; or
    - (d) Instrument indicates channel "Deactivated."
  - (2) The CHANNEL FUNCTIONAL TEST shall also demonstrate that control room annunciation occurs (for item a. below only); and that control room CRT indication occurs (if any of the following conditions exist):
    - (a) Instrument indicates measured levels above the alarm/trip setpoint;
    - (b) Instrument indicates an "Equipment Trouble" alarm;
    - (c) Instrument indicates a "Low" alarm; or
    - (d) Instrument indicates channel "Deactivated." ("Loss of counts" for ARE-16980 only)
- b. The initial CHANNEL CALIBRATION shall be performed using one or more of the reference standards certified by the National Institute of Standards and Technology, or using standards that have been obtained from suppliers that participate in measurement assurance activities with NIST. These standards shall permit calibrating the system over its intended range of energy and measurement range. For any subsequent CHANNEL CALIBRATION, sources that have been related to the initial calibration shall be used.
- c. MODES in which surveillance is required. "All" means "At all times." "During release" means "During radioactive release via this pathway."
- d. The channel check shall consist of visually verifying that the collection device (i.e., particulate filter or charcoal cartridge, etc.) is in place for sampling.
- e. The CHANNEL CALIBRATION verifies proper operation of the CHANNEL FUNCTIONAL TEST requirements described in Notation a(2) above.

---

### 3.1.2 Gaseous Effluent Dose Rate Control

In accordance with Technical Specifications 5.5.4.c and 5.5.4.g, the licensee shall conduct operations so that the dose rates due to radioactive materials released in gaseous effluents from the site to areas at and beyond the SITE BOUNDARY are limited as follows:

- a. For noble gases: Less than or equal to a dose rate of 500 mrem/y to the total body and less than or equal to a dose rate of 3000 mrem/y to the skin, and
- b. For Iodine-131, Iodine-133, tritium, and for all radionuclides in particulate form with half-lives greater than 8 days: Less than or equal to a dose rate of 1500 mrem/y to any organ.

#### 3.1.2.1 Applicability

This limit applies at all times.

#### 3.1.2.2 Actions

With a dose rate due to radioactive material released in gaseous effluents exceeding the limit stated in Section 3.1.2, immediately decrease the release rate to within the stated limit.

These limits do not affect shutdown requirements or MODE changes.

#### 3.1.2.3 Surveillance Requirements

The dose rates due to radioactive materials in areas at or beyond the SITE BOUNDARY due to releases of gaseous effluents shall be determined to be within the above limits, in accordance with the methods and procedures in Section 3.4.1, by obtaining representative samples and performing analyses in accordance with the sampling and analysis program specified in Table 3-3.

#### 3.1.2.4 Basis

This control is provided to ensure that gaseous effluent dose rates will be maintained within the limits that historically have provided reasonable assurance that radioactive material discharged in gaseous effluents will not result in a dose to a MEMBER OF THE PUBLIC in an UNRESTRICTED AREA, either within or outside the SITE BOUNDARY, exceeding the limits specified in Appendix I of 10 CFR Part 50, while allowing operational flexibility for effluent releases. For MEMBERS OF THE PUBLIC who may at times be within the SITE BOUNDARY, the occupancy of the MEMBER OF THE PUBLIC will be sufficiently low to compensate for any increase in the atmospheric diffusion factor above that for the SITE BOUNDARY.

The dose rate limit for Iodine-131, Iodine-133, tritium, and radionuclides in particulate form with half-lives greater than 8 days specifically applies to dose rates to a child via the inhalation pathway.

This control applies to the release of gaseous effluents from all reactors at the site.

Table 3-3. Radioactive Gaseous Waste Sampling and Analysis Program

| Gaseous Release Type   | Sampling and Analysis Requirements <sup>a</sup> |   |   |   |
|--|---|---|---|---|
|  | Sampling FREQUENCY                              | Minimum Analysis FREQUENCY                          | Type of Activity Analysis               | MINIMUM DETECTABLE CONCENTRATION (MDC) (μCi/mL) |
| Waste Gas Decay Tank (Common)  | P<br>Each Tank Grab Sample                      | P<br>Each Tank                                      | Noble Gas<br>PRINCIPAL GAMMA EMITTERS   | 1 E-4   |
| Containment Purge 24" or 14" (Each Unit)   | P <sup>c</sup><br>Each Purge Grab Sample        | P <sup>c</sup><br>Each Purge                        | Noble Gas<br>PRINCIPAL GAMMA EMITTERS   | 1 E-4   |
|  |   | M   | H-3 (Oxide)                             | 1 E-6   |
| Plant Vent (Each Unit)   | M <sup>c,d,f</sup><br>Grab Sample               | M <sup>c</sup>                                      | Noble Gas<br>PRINCIPAL GAMMA EMITTERS   | 1 E-4   |
|  |   |   | H-3 (Oxide)                             | 1 E-6   |
| Condenser Air Ejector & Steam Packing Exhaust (Each Unit) <sup>b</sup>             | M<br>Grab Sample                                | M   | Noble Gas<br>PRINCIPAL GAMMA EMITTERS   | 1 E-4   |
|  |   |   | H-3 (Oxide)                             | 1 E-6   |
| Plant Vent, Condenser Air Ejector & Steam Packing Exhaust (Each Unit) <sup>b</sup> | CONTINUOUS <sup>g</sup>                         | W <sup>e</sup><br>Charcoal or Silver Zeolite Sample | I-131                                   | 1 E-12  |
|  | CONTINUOUS <sup>g</sup>                         | W <sup>e</sup><br>Particulate Sample                | Particulate<br>PRINCIPAL GAMMA EMITTERS | 1 E-11  |
|  | CONTINUOUS <sup>g</sup>                         | M<br>COMPOSITE Particulate Sample                   | Gross Alpha                             | 1 E-11  |
|  | CONTINUOUS <sup>g</sup>                         | Q<br>COMPOSITE Particulate Sample                   | Sr-89, Sr-90                            | 1 E-11  |
| Radwaste Processing Facility Vent (Common)   | CONTINUOUS <sup>g</sup>                         | W <sup>h</sup><br>Particulate Sample                | Particulate<br>PRINCIPAL GAMMA EMITTERS | 1 E-11  |

Table 3-3 (contd). Notation for Table 3-3

- a. Terms printed in all capital letters are defined in Chapter 10.
- b. The turbine building vent is the release point for the condenser air ejector and steam packing exhaust. All sampling and analyses may be omitted for this vent, provided the absence of a primary to secondary leak has been demonstrated, that is, if the gamma activity in the secondary water does not exceed background by more than 20%.
- c. Sampling and analysis shall also be performed following shutdown, startup, or a THERMAL POWER change exceeding 15% of the RATED THERMAL POWER within a one-hour period. This requirement does not apply if (1) analysis shows that the DOSE EQUIVALENT I-131 concentration in the primary coolant has not increased more than a factor of 3; and (2) the noble gas monitor shows that effluent activity has not increased more than a factor of 3.
- d. Tritium grab samples shall be taken at least once per 24 hours when the refueling cavity is flooded.
- e. Samples shall be changed at least once per 7 days and analyses shall be completed within 48 hours after changing (or after removal from sampler). Sampling shall also be performed at least once per 24 hours for at least 7 days following each shutdown, startup, or THERMAL POWER change exceeding 15% of RATED THERMAL POWER in one hour, and analyses shall be completed within 48 hours of changing. When samples collected for 24 hours are analyzed, the corresponding MDC may be increased by a factor of 10. This requirement does not apply if (1) analysis shows that the DOSE EQUIVALENT I-131 concentration in the primary coolant has not increased more than a factor of 3; and (2) the noble gas monitor shows that effluent activity has not increased more than a factor of 3.
- f. Tritium grab samples shall be taken at least once per 7 days from the Unit 1 plant vent, whenever spent fuel is in the spent fuel pool (Unit 1 plant vent only).
- g. The ratio of the sample flowrate to the sampled stream flowrate shall be known for the time period covered by each dose or dose rate calculation made in accordance with controls specified in Sections 3.1.2, 3.1.3, and 3.1.4.
- h. Samples shall be changed at least once per 7 days and analyses shall be completed within 48 hours after changing (or removal of sampler).

---

### 3.1.3 Gaseous Effluent Air Dose Control

In accordance with Technical Specifications 5.5.4.e and 5.5.4.h, the air dose due to noble gases released in gaseous effluents, from each reactor unit, to areas at and beyond the SITE BOUNDARY shall be limited to the following:

- a. During any calendar quarter: Less than or equal to 5 mrad for gamma radiation and less than or equal to 10 mrad for beta radiation, and
- b. During any calendar year: Less than or equal to 10 mrad for gamma radiation and less than or equal to 20 mrad for beta radiation.

#### 3.1.3.1 Applicability

This limit applies at all times.

#### 3.1.3.2 Actions

With the calculated air dose from radioactive noble gases in gaseous effluents exceeding any of the above limits, prepare and submit to the Nuclear Regulatory Commission within 30 days a special report which identifies the cause(s) for exceeding the limit(s); defines the corrective actions that have been taken to reduce the releases; and defines the proposed corrective actions to be taken to assure that subsequent releases of radioactive noble gases in gaseous effluents will be in compliance with the limits of Section 3.1.3.

This control does not affect shutdown requirements or MODE changes.

#### 3.1.3.3 Surveillance Requirements

Cumulative air dose contributions from noble gas radionuclides released in gaseous effluents from each unit to areas at and beyond the SITE BOUNDARY, for the current calendar quarter and current calendar year, shall be determined in accordance with Section 3.4.2 at least once per 31 days.

#### 3.1.3.4 Basis

This control is provided to implement the requirements of Sections II.B, III.A and IV.A of Appendix I, 10 CFR Part 50. Section 3.1.3 implements the guides set forth in Section II.B of Appendix I. The ACTION statements in Section 3.1.3.2 provide the required operating flexibility and at the same time implement the guides set forth in Section IV.A of Appendix I, assuring that the releases of radioactive material in gaseous effluents to UNRESTRICTED AREAS will be kept "as low as is reasonably achievable." The Surveillance requirements in Section 3.1.3.3 implement the requirements in Section III.A of Appendix I, which require that conformance with the guides of Appendix I be shown by calculational procedures based on models and data such that the actual exposure of a MEMBER OF THE PUBLIC through appropriate pathways is unlikely to be substantially underestimated. The dose calculations established in Section 3.4.2 for calculating the doses due to the actual releases of noble gases in gaseous effluents are consistent with the methodology provided in Regulatory Guide 1.109 (Reference 3), and Regulatory Guide 1.111 (Reference 5). The equations in Section 3.4.2 provided for determining the air doses at the SITE BOUNDARY are based upon the historical annual average atmospheric conditions.

### 3.1.4 Control on Gaseous Effluent Dose to a Member of the Public

In accordance with Technical Specifications 5.5.4.e and 5.5.4.i, the dose to a MEMBER OF THE PUBLIC from I-131, I-133, tritium, and all radionuclides in particulate form with half-lives greater than 8 days in gaseous effluents released, from each reactor unit, to areas at and beyond the SITE BOUNDARY shall be limited to the following:

- a. During any calendar quarter: Less than or equal to 7.5 mrem to any organ, and
- b. During any calendar year: Less than or equal to 15 mrem to any organ.

#### 3.1.4.1 Applicability

This limit applies at all times.

#### 3.1.4.2 Actions

With the calculated dose from the release of I-131, I-133, tritium, or radionuclides in particulate form with half-lives greater than 8 days, in gaseous effluents exceeding any of the above limits, prepare and submit to the Nuclear Regulatory Commission within 30 days a special report which identifies the cause(s) for exceeding the limit; defines the corrective actions that have been taken to reduce the releases of radioiodines and radionuclides in particulate form with half-lives greater than 8 days in gaseous effluents; and defines proposed corrective actions to assure that subsequent releases will be in compliance with the limits stated in Section 3.1.4.

This control does not affect shutdown requirements or MODE changes.

#### 3.1.4.3 Surveillance Requirements

Cumulative organ dose contributions to a MEMBER OF THE PUBLIC from I-131, I-133, tritium, and radionuclides in particulate form with half-lives greater than 8 days released in gaseous effluents from each unit to areas at and beyond the SITE BOUNDARY, for the current calendar quarter and current calendar year, shall be determined in accordance with Section 3.4.3 at least once per 31 days.

#### 3.1.4.4 Basis

This control is provided to implement the requirements of Section II.C, III.A and IV.A of Appendix I, 10 CFR Part 50. The limits stated in Section 3.1.4 are the guides set forth in Section II.C of Appendix I. The ACTION statements in Section 3.1.4.2 provide the required operating flexibility and at the same time implement the guides set forth in Section IV.A of Appendix I to assure that the releases of radioactive materials in gaseous effluents to UNRESTRICTED AREAS will be kept "as low as is reasonably achievable." The calculational methods specified in the Surveillance Requirements of Section 3.1.4.3 implement the requirements in Section III.A of Appendix I that conformance with the guides of Appendix I be shown by calculational procedures based on models and data, such that the actual exposure of a MEMBER OF THE PUBLIC through appropriate pathways is unlikely to be substantially underestimated. The calculational methods in Section 3.4.3 for calculating the doses due to the actual releases of the subject materials are consistent with the methodology provided in Regulatory Guide 1.109 (Reference 3), and Regulatory Guide 1.111 (Reference 5). These equations provide for determining the actual doses based upon the historical annual average atmospheric conditions. The release specifications for

radioiodines, radioactive materials in particulate form and radionuclides other than noble gases are dependent on the existing radionuclide pathways to man, in the areas at and beyond the SITE BOUNDARY. The pathways which were examined in the development of these calculations were: 1) individual inhalation of airborne radionuclides, 2) deposition of radionuclides onto green leafy garden vegetation with subsequent consumption by man, 3) deposition onto grassy areas where milk animals and meat producing animals graze with consumption of the milk and meat by man, and 4) deposition on the ground with subsequent exposure of man.

### 3.1.5 Gaseous Radwaste Treatment System Control

In accordance with Technical Specification 5.5.4.f, the GASEOUS WASTE PROCESSING SYSTEM and the VENTILATION EXHAUST TREATMENT SYSTEM shall be FUNCTIONAL. The appropriate portions of the GASEOUS WASTE PROCESSING SYSTEM and the VENTILATION EXHAUST TREATMENT SYSTEM shall be used to reduce radioactive materials in gaseous wastes prior to their discharge when the projected doses in 31 days due to gaseous effluent releases, from each reactor unit, to areas at and beyond the SITE BOUNDARY would exceed 0.2 mrad to air from gamma radiation, 0.4 mrad to air from beta radiation, or 0.3 mrem to any organ of a MEMBER OF THE PUBLIC.

#### 3.1.5.1 Applicability

These limits apply at all times.

#### 3.1.5.2 Actions

With gaseous waste being discharged without treatment and in excess of the limits in Section 3.1.5, prepare and submit to the Nuclear Regulatory Commission within 30 days a special report which includes the following information:

- a. Identification of any NON-FUNCTIONAL equipment or subsystem and the reason for NON-FUNCTIONALITY,
- b. Action(s) taken to restore the NON-FUNCTIONAL equipment to FUNCTIONAL status, and
- c. Summary description of action(s) taken to prevent a recurrence.

This control does not affect shutdown requirements or MODE changes.

#### 3.1.5.3 Surveillance Requirements

Doses due to gaseous releases from each unit to areas at and beyond the SITE BOUNDARY shall be projected at least once per 31 days, in accordance with Section 3.5.1, when the GASEOUS WASTE PROCESSING SYSTEM or the VENTILATION EXHAUST TREATMENT SYSTEM is not being fully utilized.

The GASEOUS WASTE PROCESSING SYSTEM and the VENTILATION EXHAUST TREATMENT SYSTEM shall be demonstrated FUNCTIONAL:

by meeting the controls of Sections 3.1.2, and either 3.1.3 (for the GASEOUS WASTE PROCESSING SYSTEM) or 3.1.4 (for the VENTILATION EXHAUST TREATMENT SYSTEM).

#### 3.1.5.4 Basis

The FUNCTIONALITY of the GASEOUS WASTE PROCESSING SYSTEM ensures that the system will be available for use whenever gaseous effluents require treatment prior to release to the environment. The requirement that the appropriate portions of this system be used, when specified, provides reasonable assurance that the releases of radioactive materials in gaseous effluents will be kept "as low as is reasonably achievable." This control implements the requirements of 10 CFR Part 50.36a, General Design Criterion 60 of Appendix A to 10 CFR Part 50, and the design objectives given in Section II.D of Appendix I to 10 CFR Part 50. The specified limits governing the use of appropriate portions of the system were specified as a suitable fraction of the dose design objectives set forth in Section II.B and II.C of Appendix I, 10 CFR Part 50, for gaseous effluents.

This control applies to the release of radioactive materials in gaseous effluents from each unit at the site. For units with shared radwaste treatment systems, the gaseous effluents from the shared system are proportioned among the units sharing that system.

#### 3.1.6 Major Changes to Gaseous Radioactive Waste Treatment Systems

Licensee initiated MAJOR CHANGES TO GASEOUS RADIOACTIVE WASTE TREATMENT SYSTEMS:

- a. Shall be reported to the Nuclear Regulatory Commission in the Radioactive Effluents Release Report for the period in which the change was implemented. The discussion of each change shall contain the information described in Section 7.2.2.7.
- b. Shall become effective upon review by the Plant Review Board and approval by the Plant Manager.

---

### 3.2 GASEOUS WASTE PROCESSING SYSTEM

At Plant Vogtle, there are five potential points where radioactivity may be released to the atmosphere in gaseous discharges. These five *potential* release pathways are the Unit 1 and Unit 2 Plant Vents; the Unit 1 and Unit 2 Turbine Building Vents; and the Radwaste Processing Facility Vent. However, the Turbine Building Vents are not normal release pathways unless a primary-to-secondary leak exists. The Radwaste Processing Facility Vent is not a normal release pathway unless a spill occurs. The figures on the following pages give schematic diagrams of the Gaseous Waste Treatment System and the Ventilation Exhaust Treatment Systems (Reference 11).

The Unit 1 Plant Vent release pathway includes two release sources that are common to the two units: ventilation air from the Fuel Handling Building, and discharges from the GASEOUS WASTE PROCESSING SYSTEM. Otherwise, discharges from the two reactor units are separated. Reactor Containment Building ventilation releases are through the respective plant vents. The Turbine Building Vent serves as the discharge point for both the condenser air ejector and the steam packing exhaust system. The Radwaste Processing Facility Vent includes sources from the Radwaste Processing Facility Process area.

Releases from the two Turbine Building Vents and the Radwaste Processing Facility Vent are considered to be ground-level releases, whereas releases from the two Plant Vents are considered mixed-mode releases. Chapter 8 discusses the calculation of atmospheric dispersion parameters using the ground-level and mixed-mode (i.e., split-wake) models. All five potential release pathways are considered to be continuous (as opposed to batch) in nature.

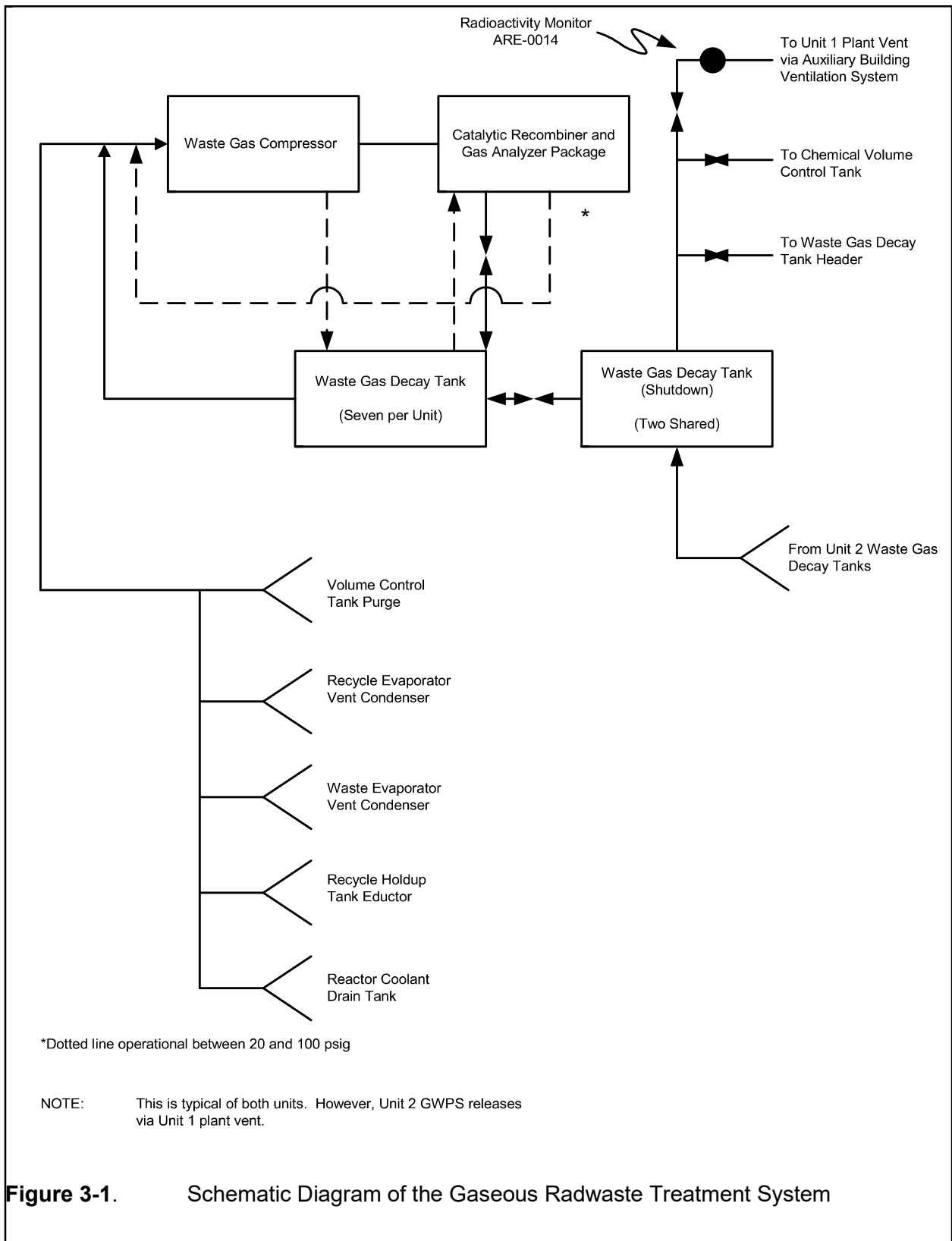

**Figure 3-1.** Schematic Diagram of the Gaseous Radwaste Treatment System

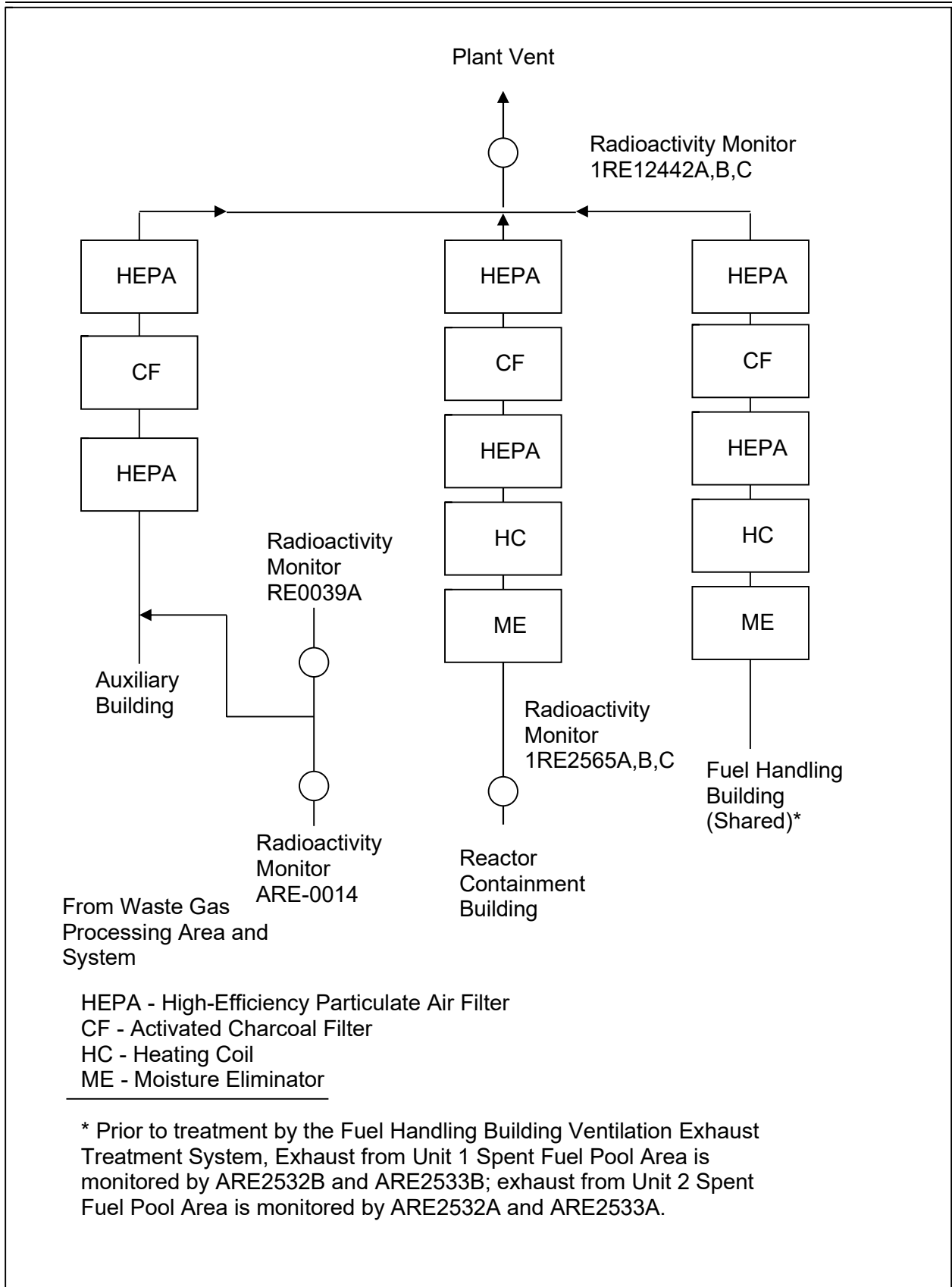

**Figure 3-2.** Schematic Diagram of the Unit 1 Plant Vent Release Pathway

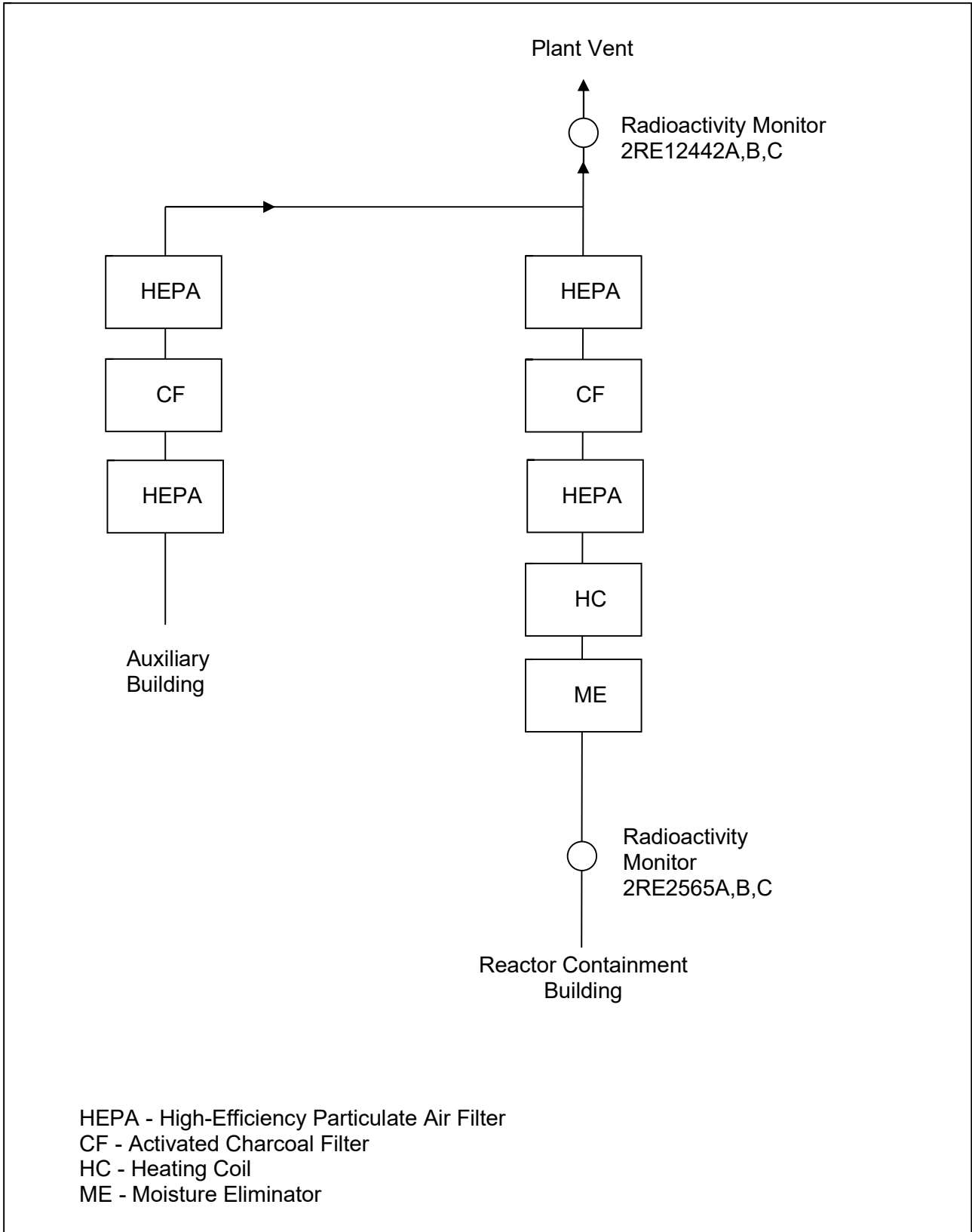

**Figure 3-3.** Schematic Diagram of the Unit 2 Plant Vent Release Pathway

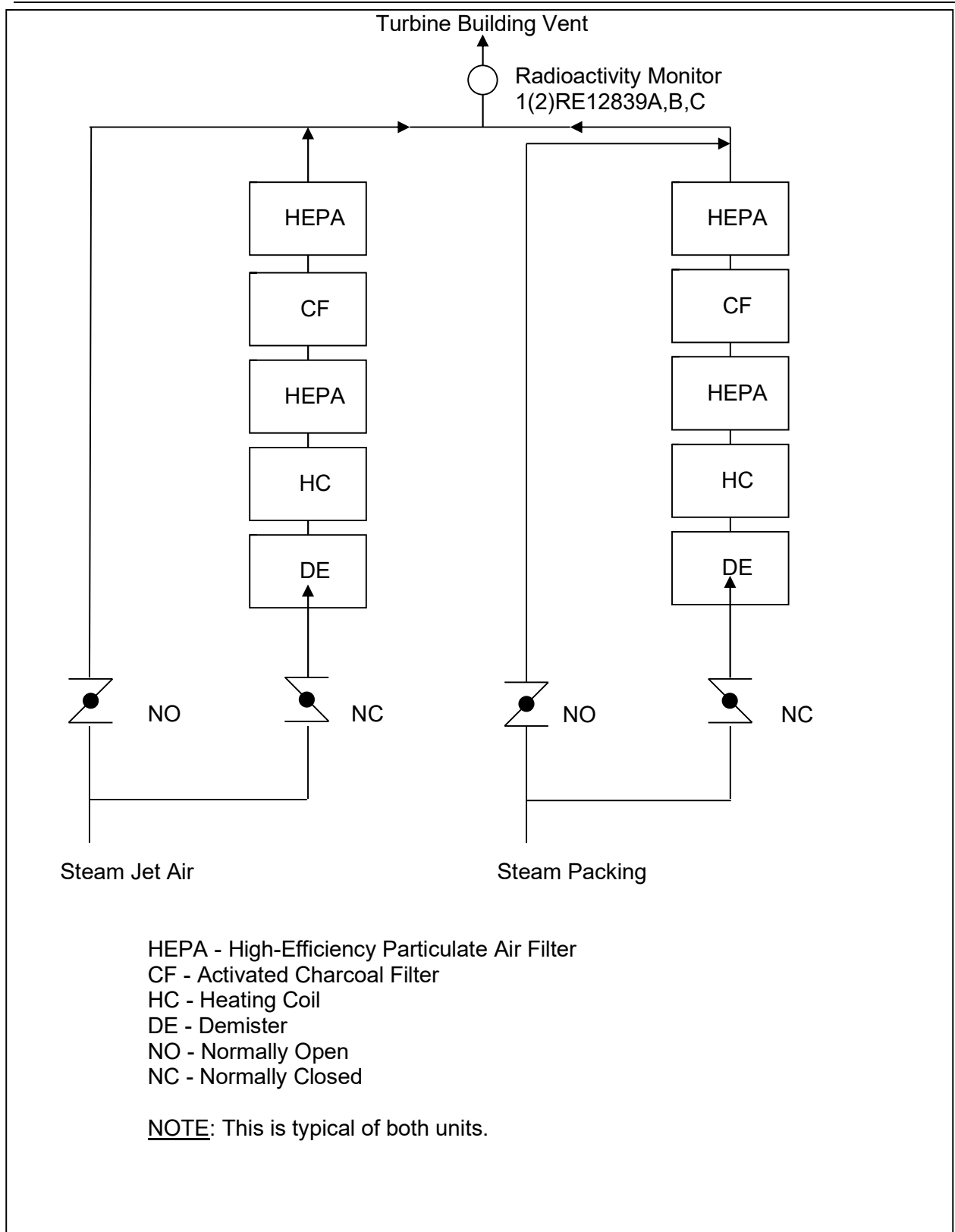

**Figure 3-4.** Schematic Diagram of the Turbine Building Vent Release Pathway (Typical of Both Units)

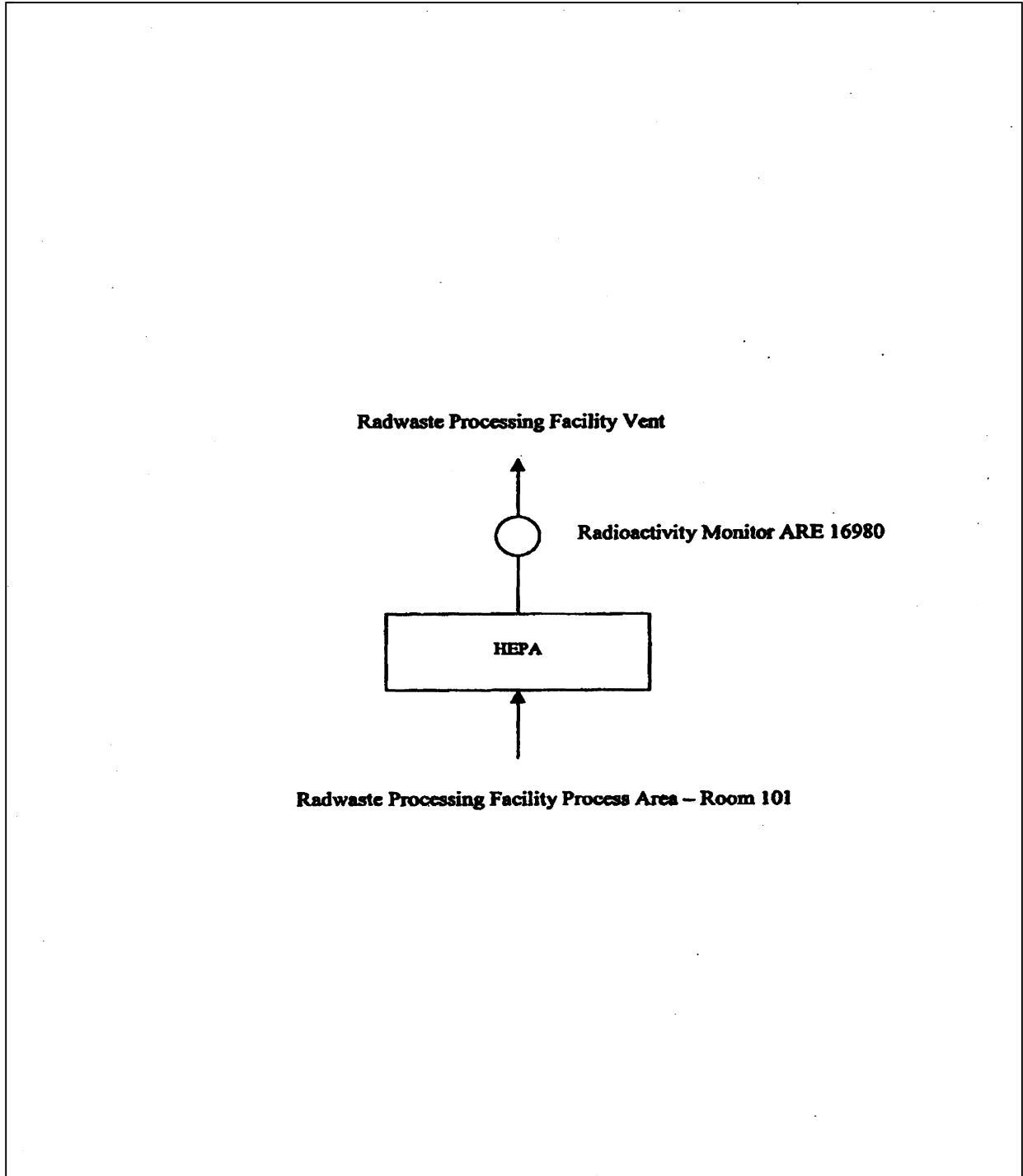

**Figure 3-5.** Schematic Diagram of the Radwaste Processing Facility Ventilation Release Pathway

---

### 3.3 GASEOUS EFFLUENT MONITOR SETPOINTS

#### 3.3.1 General Provisions Regarding Noble Gas Monitor Setpoints

Noble gas radioactivity monitor setpoints calculated in accordance with the methodology presented in this section are intended to ensure that the limits of Section 3.1.2.a are not exceeded. They will be regarded as upper bounds for the actual high alarm setpoints. That is, a lower high alarm setpoint may be established or retained on the monitor, if desired. Intermediate level setpoints should be established at an appropriate level to give sufficient warning prior to reaching the high alarm setpoint.

If no release is planned for a given pathway, or if there is no detectable activity in the gaseous stream being evaluated for release, the setpoint should be calculated in accordance with the methods presented below, based on an assumed concentration of Kr-88 that leads to a practical setpoint. A practical setpoint in this context is one which prevents spurious alarms, and yet produces an alarm should a significant inadvertent release occur.

Section 3.1.1 establishes the requirements for gaseous effluent monitoring instrumentation, and Section 3.2 describes the VENTILATION EXHAUST TREATMENT SYSTEM and the GASEOUS WASTE PROCESSING SYSTEM. From those Sections, it can be seen that certain monitors are located on final release pathways, that is, streams that are being monitored immediately before being discharged from the plant; the setpoint methodology for these monitors is presented in Section 3.3.2. Other monitors are located on source streams, that is, streams that merge with other streams prior to passing a final monitor and being discharged; the setpoint methodology for these monitors is presented in Section 3.3.3. Table 3-4 identifies which of these setpoint methodologies applies to each monitor. Some additional monitors with special setpoint requirements are discussed in Section 3.3.5.

As established in Section 3.1.1, gaseous effluent monitor setpoints are *required* only for the noble gas monitors on certain potential release streams: the two Plant Vents, the two Turbine Building Vents, and the GASEOUS WASTE PROCESSING SYSTEM discharge. However, because of the potential significance of releases from other sources, Section 3.3 discusses setpoint methodologies for certain additional monitors, as well.

Table 3-4. Applicability of Gaseous Monitor Setpoint Methodologies

**Final Release Pathways with no Monitored Source Streams**

Setpoint Method: Section 3.3.2  
 Release Elevation: Ground-level

Unit 1 or Unit 2 Turbine Building Vent

Monitor: 1RE-12839C/2RE-12839C  
 Maximum Flowrate: 900 cfm (4.25 E+05 mL/s)

**Final Release Pathways with One or More Monitored Source Streams**

Release Elevation: Mixed-Mode

Unit 1 Plant Vent

Monitors: 1RE-12442C, 1RE-12444C  
 Maximum Flowrate: 187,000 cfm (8.83 E+07 mL/s)  
 Setpoint Method: Section 3.3.2  
 Release Type: CONTINUOUS

Source Stream: Unit 1 Reactor Containment Purge

Monitor: 1RE-2565C  
 Maximum Flowrate: release-dependent  
 Setpoint Method: Section 3.3.3  
 Release Type: BATCH

Source Stream: Gaseous Waste Treatment System

Monitor: ARE-0014  
 Maximum Flowrate: release-dependent  
 Setpoint Method: Section 3.3.3  
 Release Type: BATCH

Unit 2 Plant Vent

Monitors: 2RE-12442C, 2RE-12444C  
 Maximum Flowrate: 112,500 cfm (5.31 E+07 mL/s)  
 Setpoint Method: Section 3.3.2  
 Release Type: CONTINUOUS

Source Stream: Unit 2 Reactor Containment Purge

Monitor: 2RE-2565C  
 Maximum Flowrate: release-dependent  
 Setpoint Method: Section 3.3.3  
 Release Type: BATCH

 **$(\overline{X/Q})_{vb}$  Values for Use in Setpoint Calculations**

Ground-Level Releases:  $2.55 \times 10^{-6}$  s/m<sup>3</sup> [NE Sector]

Mixed-Mode Releases:  $4.62 \times 10^{-7}$  s/m<sup>3</sup> [NE Sector]

Maximum flowrate values are from Reference 11, Table 11.5.2-1 and Table 11.5.5-1.

3.3.2 Setpoint for the Final Noble Gas Monitor on Each Release Pathway

3.3.2.1 Overview of Method

Gaseous effluent radioactivity monitors are intended to alarm prior to exceeding the limits of Section 3.1.2.a. Therefore, their alarm setpoints are established to ensure compliance with the following equation:

$$c = \text{the lesser of} \begin{cases} AG \cdot SF \cdot X \cdot R_t \\ AG \cdot SF \cdot X \cdot R_k \end{cases} \quad (3.1)$$

where:

- c = the setpoint, in  $\mu\text{Ci/mL}$ , of the radioactivity monitor measuring the concentration of radioactivity in the effluent line prior to release. The setpoint represents a concentration which, if exceeded, could result in dose rates exceeding the limits of Section 3.1.2.a at or beyond the SITE BOUNDARY.
- AG = an administrative allocation factor applied to divide the release limit among all the gaseous release pathways at the site.
- SF = the safety factor selected to compensate for statistical fluctuations and errors of measurement.
- X = the noble gas concentration for the release under consideration.
- $R_t$  = the ratio of the dose rate limit for the total body, 500 mrem/y, to the dose rate to the total body for the conditions of the release under consideration.
- $R_k$  = the ratio of the dose rate limit for the skin, 3000 mrem/y, to the dose rate to the skin for the conditions of the release under consideration.

Equation (3.1) shows the relationships of the critical parameters that determine the setpoint. However, in order to apply the methodology presented in the equation to a mixture of noble gas radionuclides, radionuclide-specific concentrations and dose factors must be taken into account under conditions of maximum flowrate for the release point and annual average meteorology.

The basic setpoint method presented below is applicable to the radioactivity monitor nearest the point of release for the release pathway. For monitors measuring the radioactivity in source streams that merge with other streams prior to subsequent monitoring and release, the modifications presented in Section 3.3.3 must be applied.

3.3.2.2 Setpoint Calculation Steps

- Step 1: Determine the concentration,  $X_{iv}$ , of each noble gas radionuclide  $i$  in the gaseous stream  $v$  being considered for release, in accordance with the sampling and analysis requirements of Section 3.1.2. Then sum these concentrations to determine the total noble gas concentration,  $\sum_i X_{iv}$ .
- Step 2: Determine  $R_t$ , the ratio of the dose rate limit for the total body, 500 mrem/y, to the total body dose rate due to noble gases detected in the release under consideration, as follows:

$$R_t = \frac{500}{(\overline{X/Q})_{vb} \sum_i [K_i \cdot Q_{iv}]} \quad (3.2)$$

where:

- 500 = the dose rate limit for the total body, 500 mrem/y.
- $(\overline{X/Q})_{vb}$  = the highest annual average relative concentration at the SITE BOUNDARY for the discharge point of release pathway v. Table 3-4 includes an indication of what release elevation is applicable to each release pathway; release elevation determines the appropriate value of  $(\overline{X/Q})_{vb}$ .
- $K_i$  = the total-body dose factor due to gamma emissions from noble gas radionuclide i, in (mrem/y)/(μCi/m<sup>3</sup>), from Table 3-5.
- $Q_{iv}$  = the release rate of noble gas radionuclide i from the release pathway under consideration, in μCi/s, calculated as the product of  $X_{iv}$  and  $f_{av}$ , where:
- $X_{iv}$  = the concentration of noble gas radionuclide i for the particular release, in μCi/mL.
- $f_{av}$  = the maximum anticipated flowrate for release pathway v during the period of the release under consideration, in mL/s.

**Step 3:** Determine  $R_k$ , the ratio of the dose rate limit for the skin, 3000 mrem/y, to the skin dose rate due to noble gases detected in the release under consideration, as follows:

$$R_k = \frac{3000}{(\overline{X/Q})_{vb} \sum_i [(L_i + 1.1M) \cdot Q_{iv}]} \quad (3.3)$$

where:

- 3000 = the dose rate limit for the skin, 3000 mrem/y.
- $L_i$  = the skin dose factor due to beta emissions from noble gas radionuclide i, in (mrem/y)/(μCi/m<sup>3</sup>), from Table 3-5.
- $M_i$  = the air dose factor due to gamma emissions from noble gas radionuclide i, in (mrad/y)/(μCi/m<sup>3</sup>), from Table 3-5.
- 1.1 = the factor to convert air dose in mrad to skin dose in mrem.

All other terms were defined previously.

**Step 4:** Determine the maximum noble gas radioactivity monitor setpoint concentration.

Based on the values determined in previous steps, the radioactivity monitor setpoint for the planned release is calculated to ensure that the limits of Section 3.1.2.a will not be exceeded.

Because the radioactivity monitor responds primarily to radiation from noble gas radionuclides, the monitor setpoint  $c_{nv}$  (in  $\mu\text{Ci}/\text{mL}$ ) is based on the concentration of all noble gases in the waste stream, as follows:

where:

$c_{nv}$  = the calculated setpoint, in  $\mu\text{Ci}/\text{mL}$ , for the noble gas monitor serving gaseous release pathway  $v$ .

$$c_{nv} = \text{the lesser of } \begin{cases} AG_v \cdot SF \cdot \sum_i X_{iv} \cdot R_t \\ AG_v \cdot SF \cdot \sum_i X_{iv} \cdot R_k \end{cases} \quad (3.4)$$

$AG_v$  = the administrative allocation factor for gaseous release pathway  $v$ , applied to divide the release limit among all the gaseous release pathways at the site. The allocation factor may be assigned any value between 0 and 1, under the condition that the sum of the allocation factors for all simultaneously-active final release pathways at the entire plant site does not exceed 1. Alternative methods for determination of  $AG_v$  are presented in Section 3.3.4.

$SF$  = the safety factor selected to compensate for statistical fluctuations and errors of measurement. The value for the safety factor must be between 0 and 1. A value of 0.5 is reasonable for gaseous releases; a more precise value may be developed if desired.

$X_{iv}$  = the measured concentration of noble gas radionuclide  $i$  in gaseous stream  $v$ , as defined in Step 1, in  $\mu\text{Ci}/\text{mL}$ .

The values of  $R_t$  and  $R_k$  to be used in the calculation are those which were determined in Steps 2 and 3 above.

**Step 5:** Determine whether the release is permissible, as follows:

If  $c_{nv} \geq \sum_i X_{iv}$ , the release is permissible. However, if  $c_{nv}$  is within about 10 percent of  $\sum_i X_{iv}$ , it may be impractical to use this value of  $c_{nv}$ . This situation indicates that measured concentrations are approaching values which would cause the limits of Section 3.1.2.a to be exceeded. Therefore, steps should be taken to reduce contributing source terms of gaseous radioactive material, or to adjust the allocation of the limits among the active release points. The setpoint calculations (steps 1–4) must then be repeated with parameters that reflect the modified conditions.

If  $c_{nv} < \sum_i X_{iv}$ , the release may not be made as planned. Consider the alternatives discussed in the paragraph above, and calculate a new setpoint based on the results of the actions taken.

### 3.3.2.3 Use of the Calculated Setpoint

The setpoint calculated above is in the units  $\mu\text{Ci}/\text{mL}$ . The monitor actually measures a count rate, subtracts a predetermined background count rate, and multiplies by a calibration factor to convert from count rate to  $\mu\text{Ci}/\text{mL}$ .

Initial calibration by the manufacturer and Georgia Power Company of the gaseous effluent monitors specified in Section 3.1.1 utilized at least one NIST-traceable gaseous radionuclide source in the exact geometry of each production monitor. The point and gaseous sources used covered the beta particle end point energy range from 0.293 MeV to at least 1.488 MeV. The calibration factor is a function of the radionuclide mix in the gas to be released, and normally will be calculated for the monitor based on the results of the sample results from the laboratory gamma-ray spectrometer system. The mix-dependent calibration factor will be used as the gain factor in the PERMS monitor, or used to modify the calculated base monitor setpoint so that the default calibration factor in the PERMS monitor can be left unchanged.

Notwithstanding the initial calibration, monitor calibration data for conversion between count rate and concentration *may* include operational data obtained from determining the monitor response to stream concentrations measured by sample analysis.

In all cases, monitor background must be controlled so that the monitor is capable of responding to concentrations in the range of the setpoint value. Contributions to the monitor background may include any or all of the following factors: ambient background radiation, plant-related radiation levels at the monitor location (which may change between shutdown and power conditions), and internal background due to contamination of the monitor's sample chamber.

### 3.3.3 Setpoints for Noble Gas Monitors on Effluent Source Streams

Table 3-4 lists certain gaseous release pathways as being source streams. As may be seen in the figures of Section 3.2, these are streams that merge with other streams, prior to passing a final radioactivity monitor and being released. Unlike the final monitors, the source stream monitors measure radioactivity in effluent streams for which flow can be terminated; therefore, the source stream monitors have control logic to terminate the source stream release at the alarm setpoint.

#### 3.3.3.1 Setpoint of the Monitor on the Source Stream

Step 1: Determine the concentration  $X_{is}$  of each noble gas radionuclide  $i$  in source stream  $s$  (in  $\mu\text{Ci/mL}$ ) according to the results of its required sample analyses [see Section 3.1.2].

Step 2: Determine  $r_t$ , the ratio of the dose rate limit for the total body, 500 mrem/y, to the total body dose rate due to noble gases detected in the source stream under consideration. Use the  $X_{is}$  values and the maximum anticipated source stream flowrate  $f_{as}$  in equation (3.2) to determine the total body dose rate for the source stream, substituting  $r_t$  for  $R_t$ .

The SITE BOUNDARY relative dispersion value used in Steps 2 and 3 for the source stream is the same as the  $(X/Q)_{vb}$  that applies to the respective merged stream. This is because the  $(X/Q)$  value is determined by the meteorology of the plant site and the physical attributes of the release point, and is unaffected by whether or not a given source stream is operating.

**Step 3:** Determine  $r_k$ , the ratio of the dose rate limit for the skin, 3000 mrem/y, to the skin dose rate due to noble gases detected in the source stream under consideration. Use the  $X_{is}$  values and the maximum anticipated source stream flow rate  $f_{as}$  in equation (3.3) to determine the skin dose rate for the source stream, substituting  $r_k$  for  $R_k$ .

**Step 4:** Determine the maximum noble gas radioactivity monitor setpoint concentration, as follows:

$$c_{ns} = \text{the lesser of } \begin{cases} AG_s \cdot SF \cdot \sum_i X_{is} \cdot r_t \\ AG_s \cdot SF \cdot \sum_i X_{is} \cdot r_k \end{cases} \quad (3.5)$$

where:

- $c_{ns}$  = the calculated setpoint (in  $\mu\text{Ci/mL}$ ) for the noble gas monitor serving gaseous source stream  $s$ .
- $AG_s$  = the administrative allocation factor applied to gaseous source stream  $s$ . For a given final release point  $v$ , the sum of all the  $AG_s$  values for source streams contributing to the final release point must not exceed the release point's allocation factor  $Ag_v$ .
- $X_{is}$  = the measured concentration of noble gas radionuclide  $i$  in gaseous source stream  $s$ , as defined in Step 1, in  $\mu\text{Ci/mL}$ .

The values of  $r_t$  and  $r_k$  to be used in the calculation are those which were determined in Steps 2 and 3 above. The safety factor,  $SF$ , was defined previously.

**Step 5:** Determine whether the release is permissible, as follows:

If  $c_{ns} \geq \sum_i X_{is}$ , the release is permissible. However, if  $c_{ns}$  is within about 10 percent of  $\sum_i X_{is}$ , it may be impractical to use this value of  $c_{ns}$ . This situation indicates that measured concentrations are approaching values which would cause the limits of Section 3.1.2.a to be exceeded. Therefore, steps should be taken to reduce contributing source terms of gaseous radioactive material, or to adjust the allocation of the limits among the active release points. The setpoint calculations (steps 1–4) must then be repeated with parameters that reflect the modified conditions.

If  $c_{ns} < \sum_i X_{is}$ , the release may not be made as planned. Consider the alternatives discussed in the paragraph above, and calculate a new setpoint based on the results of the actions taken.

### 3.3.3.2 Effect on the Setpoint of the Monitor on the Merged Stream

Before beginning a release from a monitored source stream, a setpoint must be determined for the source stream monitor as presented in Section 3.3.3.1. In addition, whether or not the source stream has its own effluent monitor, the previously-determined maximum allowable setpoint for the downstream final monitor on the merged stream must be redetermined. This is accomplished by repeating the steps of Section 3.3.2, with the following modifications.

Modification 1: The new maximum anticipated flowrate of the merged stream is the sum of the old merged stream maximum flowrate, and the maximum flowrate of the source stream being considered for release.

$$(f_{av})_{new} = (f_{av})_{old} + f_{as} \quad (3.6)$$

Modification 2: The new concentration of noble gas radionuclide *i* in the merged stream includes both the contribution of the merged stream *without* the source stream, *and* the source stream being considered for release.

$$(X_{iv})_{new} = \frac{(f_{av})_{old} \cdot (X_{iv})_{old} + f_{as} \cdot X_{is}}{(f_{av})_{new}} \quad (3.7)$$

### 3.3.4 Determination of Allocation Factors, AG

When simultaneous gaseous releases are conducted, an administrative allocation factor must be applied to divide the release limit among the active gaseous release pathways. This is to assure that the dose rate limit for areas at and beyond the SITE BOUNDARY (see Section 3.1.2) will not be exceeded by simultaneous releases. The allocation factor for any pathway may be assigned any value between 0 and 1, under the following two conditions:

1. The sum of the allocation factors for all simultaneously-active *final* release paths at the plant site may not exceed 1.
2. The sum of the allocation factors for all simultaneously-active *source streams* merging into a given final release pathway may not exceed the allocation factor of that final release pathway.

Any of the following three methods may be used to assign the allocation factors to the active gaseous release pathways:

1. For ease of implementation,  $AG_v$  may be equal for all release pathways:

$$AG_v = \frac{1}{N} \quad (3.8)$$

where:

$N$  = the number of simultaneously active gaseous release pathways.

2.  $AG_v$  for a given release pathway may be selected based on an *estimate* of the portion of the total SITE BOUNDARY dose rate (from all simultaneous releases) that is contributed by the release pathway. During periods when a given building or release pathway is not subject to gaseous radioactive releases, it may be assigned an allocation factor of zero.
3.  $AG_v$  for a given release pathway may be selected based on a *calculation* of the portion of the total SITE BOUNDARY dose rate that is contributed by the release pathway, as follows:

$$AG_v = \frac{(\overline{X/Q})_{vb} \sum_i (K_i Q_{iv})}{\sum_{r=1}^N \left[ (\overline{X/Q})_{rb} \sum_i (K_i Q_{ir}) \right]} \quad (3.9)$$

where:

$(\overline{X/Q})_{vb}$  = the annual average SITE BOUNDARY relative concentration applicable to the gaseous release pathway v for which the allocation factor is being determined, in s/m<sup>3</sup>.

$K_i$  = the total-body dose factor due to gamma emissions from noble gas radionuclide i, in (mrem/y)/(μCi/m<sup>3</sup>), from Table 3-5.

$Q_{iv}$  = the release rate of noble gas radionuclide i from release pathway v, in μCi/s, calculated as the product of  $X_{iv}$  and  $f_{av}$ , where:

$X_{iv}$  = the concentration of noble gas radionuclide i applicable to the gaseous release pathway v for which the allocation factor is being determined, in μCi/mL.

$f_{av}$  = the discharge flowrate applicable to gaseous release pathway v for which the allocation factor is being determined, in mL/s.

$(\overline{X/Q})_{rb}$  = the annual average SITE BOUNDARY relative concentration applicable to active gaseous release pathway r, in s/m<sup>3</sup>.

$Q_{ir}$  = the release rate of noble gas radionuclide i applicable to active release pathway r, in μCi/s, calculated as the product of  $X_{ir}$  and  $f_{ar}$ , where:

$X_{ir}$  = the concentration of noble gas radionuclide i applicable to active gaseous release pathway r, in μCi/mL.

$f_{ar}$  = the discharge flowrate applicable to active gaseous release pathway r, in mL/s.

$N$  = the number of simultaneously active gaseous release pathways (including pathway v that is of interest).

**NOTE:** Although equations (3.8) and (3.9) are written to illustrate the assignment of the allocation factors for final release pathways, they may also be used to assign allocation factors to the source streams that merge into a given final release pathway.

### 3.3.5 Setpoints for Noble Gas Monitors with Special Requirements

At present, VEGP has no noble gas monitors for which setpoint methodologies are to be presented in the ODCM, and that require methods other than those in Section 3.3.2 or Section 3.3.3.

### 3.3.6 Setpoints for Particulate and Iodine Monitors

In accordance with Section 5.1.1 of NRC NUREG-0133 (Reference 1), the effluent controls of Section 3.1.1 do not require that the ODCM establish setpoint calculation methods for particulate and iodine monitors. Therefore, the following is provided for information only: Initial setpoints for the particulate channels of effluent monitors RE-12442 and RE-2565 were determined as described in Reference 13.

3.4 GASEOUS EFFLUENT COMPLIANCE CALCULATIONS

3.4.1 Dose Rates at and Beyond the Site Boundary

Because the dose rate limits for areas at and beyond the SITE specified in Section 3.1.2 are *site* limits applicable at any instant in time, the summations extend over all simultaneously active gaseous final release pathways at the *plant site*. Table 3-4 identifies the gaseous final release pathways at the plant site, and indicates the  $(\overline{X/Q})_{vb}$  value for each.

3.4.1.1 Dose Rates Due to Noble Gases

For the purpose of implementing the controls of Section 3.1.2.a, the dose rates due to noble gas radionuclides in areas at or beyond the SITE BOUNDARY, due to releases of gaseous effluents, shall be calculated as follows:

For total body dose rates:

$$DR_t = \sum_v \left\{ (\overline{X/Q})_{vb} \sum_i [K_i Q_{iv}] \right\} \tag{3.10}$$

For skin dose rates:

$$DR_k = \sum_v \left\{ (\overline{X/Q})_{vb} \sum_i [(L_i + 1.1M_i) Q_{iv}] \right\} \tag{3.11}$$

where:

- DR<sub>t</sub> = the total body dose rate at the time of the release, in mrem/y.
- DR<sub>k</sub> = the skin dose rate at the time of the release, in mrem/y.
- Q<sub>iv</sub> = the release rate of noble gas radionuclide i, in μCi/s, equal to the product of f<sub>iv</sub> and X<sub>iv</sub>, where:
- f<sub>iv</sub> = the actual average flowrate for release pathway v during the period of the release, in mL/s.

All other terms were defined previously.

3.4.1.2 Dose Rates Due to Iodine-131, Iodine-133, Tritium, and Radionuclides in Particulate Form with Half-Lives Greater than 8 Days

For the purpose of implementing the controls of Section 3.1.2.b, the dose rates due to Iodine-131, Iodine-133, tritium, and all radionuclides in particulate form with half-lives greater than 8 days, in areas at or beyond the SITE BOUNDARY, due to releases of gaseous effluents, shall be calculated as follows:

$$DR_o = \sum_v \left\{ (\overline{X/Q})_{vb} \sum_i [P_{io} Q'_{iv}] \right\} \tag{3.12}$$

where:

- DR<sub>o</sub> = the dose rate to organ o at the time of the release, in mrem/y.

- $P_{io}$  = the site-specific dose factor for radionuclide  $i$  and organ  $o$ , in (mrem/y)/(μCi/m<sup>3</sup>). Since the dose rate limits specified in Section 3.1.2.b apply only to the child age group exposed to the inhalation pathway, the values of  $P_{io}$  may be obtained from Table 3-9, “ $R_{aipj}$  for Inhalation Pathway, Child Age Group.”
- $Q'_{iv}$  = the release rate of radionuclide  $i$  from gaseous release pathway  $v$ , in μCi/s. For the purpose of implementing the controls of Section 3.1.2.b, only I-131, I-133, tritium, and all radionuclides in particulate form with half-lives greater than 8 days should be included in this calculation.

All other terms were defined previously.

### 3.4.2 Noble Gas Air Dose at or Beyond Site Boundary

For the purpose of implementing the controls of Section 3.1.3, air doses in areas at or beyond the SITE BOUNDARY due to releases of noble gases from each unit shall be calculated as follows (adapted from Reference 1, page 28, by including only long-term releases):

$$D_{\beta} = 3.17 \times 10^{-8} \sum_v \left\{ \left( \overline{X/Q} \right)_{vb} \sum_i \left[ N_i \cdot \tilde{Q}_{iv} \right] \right\} \quad (3.13)$$

$$D_{\gamma} = 3.17 \times 10^{-8} \sum_v \left\{ \left( \overline{X/\Gamma} \right)_{vb} \sum_i \left[ M_i \cdot \tilde{Q}_{iv} \right] \right\} \quad (3.14)$$

where:

$3.17 \times 10^{-8}$  = a units conversion factor:  $1 \text{ y} / (3.15 \times 10^7 \text{ s})$ .

- $D_{\beta}$  = the air dose due to beta emissions from noble gas radionuclides, in mrad.
- $D_{\gamma}$  = the air dose due to gamma emissions from noble gas radionuclides, in mrad.
- $N_i$  = the air dose factor due to beta emissions from noble gas radionuclide  $i$  (mrad/y)/(μCi/m<sup>3</sup>), from Table 3-5.
- $M_i$  = the air dose factor due to gamma emissions from noble gas radionuclide  $i$  (mrad/y)/(μCi/m<sup>3</sup>), from Table 3-5.
- $\tilde{Q}_{iv}$  = the cumulative release of noble gas radionuclide  $i$  from release pathway  $v$  (μCi), during the period of interest.

and all other terms are as defined above.

Because the air dose limit is on a per-reactor-unit basis, the summations extend over all gaseous final release pathways for a given *unit*. For a release pathway discharging materials originating in both reactor units, the activity discharged from the release point may be apportioned to the two units in any reasonable manner, provided that all activity released via the particular shared release pathway is apportioned to one or the other unit.

The gaseous final release pathways at the plant site, and the  $\overline{(X/Q)}_{vb}$  for each, are identified in Table 3-4.

Table 3-5. Dose Factors for Exposure to a Semi-Infinite Cloud of Noble Gases

| Nuclide | $\gamma$ - Body (K)<br>(mrem/y) per<br>( $\mu\text{Ci}/\text{m}^3$ ) | $\beta$ - Skin (L)<br>(mrem/y) per<br>( $\mu\text{Ci}/\text{m}^3$ ) | $\gamma$ - Air (M)<br>(mrad/y) per<br>( $\mu\text{Ci}/\text{m}^3$ ) | $\beta$ - Air (N)<br>(mrad/y) per<br>( $\mu\text{Ci}/\text{m}^3$ ) |
|---------|--|---|---|--|
| Kr-83m  | 7.56 E-02  | 0.00 E+00   | 1.93 E+01   | 2.88 E+02  |
| Kr-85m  | 1.17 E+03  | 1.46 E+03   | 1.23 E+03   | 1.97 E+03  |
| Kr-85   | 1.61 E+01  | 1.34 E+03   | 1.72 E+01   | 1.95 E+03  |
| Kr-87   | 5.92 E+03  | 9.73 E+03   | 6.17 E+03   | 1.03 E+04  |
| Kr-88   | 1.47 E+04  | 2.37 E+03   | 1.52 E+04   | 2.93 E+03  |
| Kr-89   | 1.66 E+04  | 1.01 E+04   | 1.73 E+04   | 1.06 E+04  |
| Kr-90   | 1.56 E+04  | 7.29 E+03   | 1.63 E+04   | 7.83 E+03  |
| Xe-131m | 9.15 E+01  | 4.76 E+02   | 1.56 E+02   | 1.11 E+03  |
| Xe-133m | 2.51 E+02  | 9.94 E+02   | 3.27 E+02   | 1.48 E+03  |
| Xe-133  | 2.94 E+02  | 3.06 E+02   | 3.53 E+02   | 1.05 E+03  |
| Xe-135m | 3.12 E+03  | 7.11 E+02   | 3.36 E+03   | 7.39 E+02  |
| Xe-135  | 1.81 E+03  | 1.86 E+03   | 1.92 E+03   | 2.46 E+03  |
| Xe-137  | 1.42 E+03  | 1.22 E+04   | 1.51 E+03   | 1.27 E+04  |
| Xe-138  | 8.83 E+03  | 4.13 E+03   | 9.21 E+03   | 4.75 E+03  |
| Ar-41   | 8.84 E+03  | 2.69 E+03   | 9.30 E+03   | 3.28 E+03  |

All values in this table were obtained from Reference 3 (Table B-1), with units converted.

---

Table 3-6. Dose Factors for Exposure to Direct Radiation from Noble Gases in an Elevated Finite Plume

---

The contents of this table are not applicable to VEGP.

3.4.3 Dose to a Member of the Public at or Beyond Site Boundary

The dose received by an individual due to gaseous releases from each reactor unit, to areas at or beyond the SITE BOUNDARY, depends on the individual's location, age group, and exposure pathways. The MEMBER OF THE PUBLIC expected to receive the highest dose in the plant vicinity is referred to as the controlling receptor. The dosimetrically-significant attributes of the currently-defined controlling receptor are presented in Table 3-7.

Doses to a MEMBER OF THE PUBLIC due to gaseous releases of I-131, I-133, tritium, and all radionuclides in particulate form from each unit shall be calculated as follows (equation adapted from Reference 1, page 29, by considering only long-term releases):

$$D_{ja} = 3.17 \times 10^{-8} \sum_p \left\{ \sum_i R_{aipj} \sum_v \left[ W_{vip} \cdot \tilde{Q}'_{iv} \right] \right\} \tag{3.15}$$

where:

$D_{ja}$  = the dose to organ j of an individual in age group a, due to gaseous releases of I-131, I-133, tritium, and all radionuclides in particulate form with half-lives greater than 8 days, in mrem.

$3.17 \times 10^{-8}$  = a units conversion factor:  $1 \text{ y}/(3.15 \times 10^7 \text{ s})$ .

$R_{aipj}$  = the site-specific dose factor for age group a, radionuclide i, exposure pathway p, and organ j. For the purpose of implementing the controls of Section 3.1.4, the exposure pathways applicable to calculating the dose to the currently-defined controlling receptor are included in Table 3-7; values of  $R_{aipj}$  for each exposure pathway and radionuclide applicable to calculations of dose to the controlling receptor are included in Tables 3-8 through 3-12.

A detailed discussion of the methods and parameters used for calculating  $R_{aipj}$  for the plant site is presented in Chapter 9. That information may be used for recalculating the  $R_{aipj}$  values if the underlying parameters change, or for calculating  $R_{aipj}$  values for special radionuclides and age groups when performing the assessments discussed in Section 3.4.4 below.

$W_{vip}$  = the annual average relative dispersion or deposition at the location of the controlling receptor, for release pathway v, as appropriate to exposure pathway p and radionuclide i.

For all tritium pathways, and for the inhalation of any radionuclide:  $W_{vip}$  is  $(\overline{X/Q})_{vp}$ , the annual average relative dispersion factor for release pathway v, at the location of the controlling receptor ( $\text{s/m}^3$ ). For the ground-plane exposure pathway, and for all ingestion-related pathways for radionuclides other than tritium:  $W_{vip}$  is  $(\overline{D/Q})_{vp}$ , the annual average relative deposition factor for release pathway v, at the location of the controlling receptor ( $\text{m}^{-2}$ ). Values of  $(\overline{X/Q})_{vp}$  and  $(\overline{D/Q})_{vp}$  for use in calculating the dose to the currently-defined controlling receptor are included in Table 3-7.

---

$\tilde{Q}'_{iv}$  = the cumulative release of radionuclide  $i$  from release pathway  $v$ , during the period of interest ( $\mu\text{Ci}$ ). For the purpose of implementing the controls of Section 3.1.4, only I-131, I-133, tritium, and all radionuclides in particulate form with half-lives greater than 8 days should be included in this calculation. In any dose assessment using the methods of this subsection, only radionuclides detectable above background in their respective samples should be included in the calculation.

Because the member of the public dose limit is on a per-unit basis, the summations extend over all gaseous final release pathways for a given *unit*. For a release pathway discharging materials originating in both reactor units, the activity discharged from the release point may be apportioned between the two units in any reasonable manner, provided that all activity released from the plant site is apportioned to one or the other unit.

The gaseous final release pathways at the plant site, and the release elevation for each, are identified in Table 3-4.

Table 3-7. Attributes of the Controlling Receptor

The locations of members of the public in the vicinity of the plant site, and the exposure pathways associated with those locations, are determined in the Annual Land Use Census. Dispersion and deposition values were calculated based on site meteorological data collected for the period January 1, 1985 through December 31, 1987.

Based on an analysis of this information, the current controlling receptor for the plant site is described as follows.

Sector: WSW  
Distance: 1.2 miles  
Age Group: Child  
Exposure Pathways: Inhalation, ground plane, cow meat, and garden vegetation

Dispersion Factors  $(X/Q)_{vb}$  :

Ground-Level release points: 6.20 E-7 s/m<sup>3</sup>  
 Mixed-Mode release points: 1.27 E-7 s/m<sup>3</sup>

Deposition Factors  $(D/Q)_{vb}$  :

Ground-Level release points: 2.80 E-9 m<sup>-2</sup>  
 Mixed-Mode release points: 9.90 E-10 m<sup>-2</sup>

### 3.4.4 Dose Calculations to Support Other Requirements

Case 1: A radiological impact assessment may be required to support evaluation of a reportable event.

Dose calculations may be performed using the equations in Section 3.4.3, with the substitution of the dispersion and deposition parameters [(X/Q) and (D/Q)] for the period covered by the report, and using the appropriate pathway dose factors ( $R_{aipj}$ ) for the receptor of interest. Methods for calculating (X/Q) and (D/Q) from meteorological data are presented in Chapter 8.

Values of  $R_{aipj}$  other than those presented in Tables 3-8 through 3-12 may need to be calculated. Methods and parameters for calculating values of  $R_{aipj}$  are presented in Chapter 9. When calculating  $R_{aipj}$  for evaluation of an event, pathway and usage factors specific to the receptor involved in the event may be used in place of the values in Chapter 9, if the specific values are known.

Case 2: A dose calculation is required to evaluate the results of the Land Use Census, under the provisions of Section 4.1.2.

In the event that the Land Use Census reveals that exposure pathways have changed at previously-identified locations, or if new locations are identified, it may be necessary to calculate doses at two or more locations to determine which should be designated as the controlling receptor. Such dose calculations may be performed using the equations in Section 3.4.3, with the substitution of the annual average dispersion and deposition values [ $\overline{(X/Q)}$  and  $\overline{(D/Q)}$ ] for the locations of interest, and using the appropriate pathway dose factors ( $R_{aipj}$ ) for the receptors of interest.

Methods for calculating (X/Q) and (D/Q) from meteorological data are presented in Chapter 8. The values of  $R_{aipj}$  other than those presented in Tables 3-8 through 3-12 may need to be calculated. Methods and parameters for calculating values of  $R_{aipj}$  are presented in Chapter 9.

Case 3: Under Section 5.2, a dose calculation may be required to support the determination of a component of the total dose to a receptor other than that currently defined as the controlling receptor.

Dose calculations would be performed using the equations in Section 3.4.3, with the dispersion and deposition parameters and appropriate values of ( $R_{aipj}$ ) for the receptor of interest.

Appropriate values of the dispersion and deposition parameters, if not found in Table 3-7, would need to be calculated. Methods for calculating (X/Q) and (D/Q) from meteorological data are presented in Chapter 8.

Appropriate values of  $R_{aipj}$ , if not found in Tables 3-8 through 3-12, would need to be calculated. Methods and parameters for calculating values of  $R_{aipj}$  are presented in Chapter 9.

Table 3-8.  $R_{aij}$  for Ground Plane Pathway, All Age Groups

| Nuclide | T. Body  | Skin     |
|---------|----------|----------|
| H-3     | 0.00     | 0.00     |
| C-14    | 0.00     | 0.00     |
| P-32    | 0.00     | 0.00     |
| Cr-51   | 4.66E+06 | 5.51E+06 |
| Mn-54   | 1.39E+09 | 1.63E+09 |
| Fe-55   | 0.00     | 0.00     |
| Fe-59   | 2.73E+08 | 3.21E+08 |
| Co-58   | 3.79E+08 | 4.44E+08 |
| Co-60   | 2.15E+10 | 2.53E+10 |
| Ni-63   | 0.00     | 0.00     |
| Zn-65   | 7.47E+08 | 8.59E+08 |
| Rb-86   | 8.99E+06 | 1.03E+07 |
| Sr-89   | 2.16E+04 | 2.51E+04 |
| Sr-90   | 0.00     | 0.00     |
| Y-91    | 1.07E+06 | 1.21E+06 |
| Zr-95   | 2.45E+08 | 2.84E+08 |
| Nb-95   | 1.37E+08 | 1.61E+08 |
| Ru-103  | 1.08E+08 | 1.26E+08 |
| Ru-106  | 4.22E+08 | 5.07E+08 |
| Ag-110m | 3.44E+09 | 4.01E+09 |
| Sb-124  | 5.98E+08 | 6.90E+08 |
| Sb-125  | 2.34E+09 | 2.64E+09 |
| Te-125m | 1.55E+06 | 2.13E+06 |
| Te-127m | 9.16E+04 | 1.08E+05 |
| Te-129m | 1.98E+07 | 2.31E+07 |
| I-131   | 1.72E+07 | 2.09E+07 |
| I-133   | 2.45E+06 | 2.98E+06 |
| Cs-134  | 6.86E+09 | 8.00E+09 |
| Cs-136  | 1.51E+08 | 1.71E+08 |
| Cs-137  | 1.03E+10 | 1.20E+10 |
| Ba-140  | 2.05E+07 | 2.35E+07 |
| Ce-141  | 1.37E+07 | 1.54E+07 |
| Ce-144  | 6.95E+07 | 8.04E+07 |
| Pr-143  | 0.00     | 0.00     |
| Nd-147  | 8.39E+06 | 1.01E+07 |

1. Units are  $m^2 \cdot (mrem/yr) / (\mu Ci/s)$ .
2. The values in the Total Body column also apply to the Bone, Liver, Thyroid, Kidney, Lung, and GI-LLI organs.
3. This table also supports the calculations of section 6.2.

Table 3-9.  $R_{aij}$  for Inhalation Pathway, Child Age Group

| Nuclide | Bone     | Liver    | T. Body  | Thyroid  | Kidney   | Lung     | GI-LLI   |
|---------|----------|----------|----------|----------|----------|----------|----------|
| H-3     | 0.00     | 1.12E+03 | 1.12E+03 | 1.12E+03 | 1.12E+03 | 1.12E+03 | 1.12E+03 |
| C-14    | 3.59E+04 | 6.73E+03 | 6.73E+03 | 6.73E+03 | 6.73E+03 | 6.73E+03 | 6.73E+03 |
| P-32    | 2.60E+06 | 1.14E+05 | 9.88E+04 | 0.00     | 0.00     | 0.00     | 4.22E+04 |
| Cr-51   | 0.00     | 0.00     | 1.54E+02 | 8.55E+01 | 2.43E+01 | 1.70E+04 | 1.08E+03 |
| Mn-54   | 0.00     | 4.29E+04 | 9.51E+03 | 0.00     | 1.00E+04 | 1.58E+06 | 2.29E+04 |
| Fe-55   | 4.74E+04 | 2.52E+04 | 7.77E+03 | 0.00     | 0.00     | 1.11E+05 | 2.87E+03 |
| Fe-59   | 2.07E+04 | 3.34E+04 | 1.67E+04 | 0.00     | 0.00     | 1.27E+06 | 7.07E+04 |
| Co-58   | 0.00     | 1.77E+03 | 3.16E+03 | 0.00     | 0.00     | 1.11E+06 | 3.44E+04 |
| Co-60   | 0.00     | 1.31E+04 | 2.26E+04 | 0.00     | 0.00     | 7.07E+06 | 9.62E+04 |
| Ni-63   | 8.21E+05 | 4.63E+04 | 2.80E+04 | 0.00     | 0.00     | 2.75E+05 | 6.33E+03 |
| Zn-65   | 4.26E+04 | 1.13E+05 | 7.03E+04 | 0.00     | 7.14E+04 | 9.95E+05 | 1.63E+04 |
| Rb-86   | 0.00     | 1.98E+05 | 1.14E+05 | 0.00     | 0.00     | 0.00     | 7.99E+03 |
| Sr-89   | 5.99E+05 | 0.00     | 1.72E+04 | 0.00     | 0.00     | 2.16E+06 | 1.67E+05 |
| Sr-90   | 1.01E+08 | 0.00     | 6.44E+06 | 0.00     | 0.00     | 1.48E+07 | 3.43E+05 |
| Y-91    | 9.14E+05 | 0.00     | 2.44E+04 | 0.00     | 0.00     | 2.63E+06 | 1.84E+05 |
| Zr-95   | 1.90E+05 | 4.18E+04 | 3.70E+04 | 0.00     | 5.96E+04 | 2.23E+06 | 6.11E+04 |
| Nb-95   | 2.35E+04 | 9.18E+03 | 6.55E+03 | 0.00     | 8.62E+03 | 6.14E+05 | 3.70E+04 |
| Ru-103  | 2.79E+03 | 0.00     | 1.07E+03 | 0.00     | 7.03E+03 | 6.62E+05 | 4.48E+04 |
| Ru-106  | 1.36E+05 | 0.00     | 1.69E+04 | 0.00     | 1.84E+05 | 1.43E+07 | 4.29E+05 |
| Ag-110m | 1.69E+04 | 1.14E+04 | 9.14E+03 | 0.00     | 2.12E+04 | 5.48E+06 | 1.00E+05 |
| Sb-124  | 0.00     | 0.00     | 0.00     | 0.00     | 0.00     | 0.00     | 0.00     |
| Sb-125  | 0.00     | 0.00     | 0.00     | 0.00     | 0.00     | 0.00     | 0.00     |
| Te-125m | 6.73E+03 | 2.33E+03 | 9.14E+02 | 1.92E+03 | 0.00     | 4.77E+05 | 3.38E+04 |
| Te-127m | 2.49E+04 | 8.55E+03 | 3.02E+03 | 6.07E+03 | 6.36E+04 | 1.48E+06 | 7.14E+04 |
| Te-129m | 1.92E+04 | 6.85E+03 | 3.04E+03 | 6.33E+03 | 5.03E+04 | 1.76E+06 | 1.82E+05 |
| I-131   | 4.81E+04 | 4.81E+04 | 2.73E+04 | 1.62E+07 | 7.88E+04 | 0.00     | 2.84E+03 |
| I-133   | 1.66E+04 | 2.03E+04 | 7.70E+03 | 3.85E+06 | 3.38E+04 | 0.00     | 5.48E+03 |
| Cs-134  | 6.51E+05 | 1.01E+06 | 2.25E+05 | 0.00     | 3.30E+05 | 1.21E+05 | 3.85E+03 |
| Cs-136  | 6.51E+04 | 1.71E+05 | 1.16E+05 | 0.00     | 9.55E+04 | 1.45E+04 | 4.18E+03 |
| Cs-137  | 9.07E+05 | 8.25E+05 | 1.28E+05 | 0.00     | 2.82E+05 | 1.04E+05 | 3.62E+03 |
| Ba-140  | 7.40E+04 | 6.48E+01 | 4.33E+03 | 0.00     | 2.11E+01 | 1.74E+06 | 1.02E+05 |
| Ce-141  | 3.92E+04 | 1.95E+04 | 2.90E+03 | 0.00     | 8.55E+03 | 5.44E+05 | 5.66E+04 |
| Ce-144  | 6.77E+06 | 2.12E+06 | 3.61E+05 | 0.00     | 1.17E+06 | 1.20E+07 | 3.89E+05 |
| Pr-143  | 1.85E+04 | 5.55E+03 | 9.14E+02 | 0.00     | 3.00E+03 | 4.33E+05 | 9.73E+04 |
| Nd-147  | 1.08E+04 | 8.73E+03 | 6.81E+02 | 0.00     | 4.81E+03 | 3.28E+05 | 8.21E+04 |

1. Units are (mrem/yr)/( $\mu\text{Ci}/\text{m}^3$ ) for all radionuclides.
2. This table also supports the calculations of section 6.2.

Table 3-10.  $R_{aij}$  for Inhalation Pathway, Adult Age Group

| Nuclide | Bone     | Liver    | T. Body  | Thyroid  | Kidney   | Lung     | GI-LLI   |
|---------|----------|----------|----------|----------|----------|----------|----------|
| H-3     | 0.00     | 1.26E+03 | 1.26E+03 | 1.26E+03 | 1.26E+03 | 1.26E+03 | 1.26E+03 |
| C-14    | 1.82E+04 | 3.41E+03 | 3.41E+03 | 3.41E+03 | 3.41E+03 | 3.41E+03 | 3.41E+03 |
| P-32    | 1.32E+06 | 7.71E+04 | 5.01E+04 | 0.00     | 0.00     | 0.00     | 8.64E+04 |
| Cr-51   | 0.00     | 0.00     | 1.00E+02 | 5.95E+01 | 2.28E+01 | 1.44E+04 | 3.32E+03 |
| Mn-54   | 0.00     | 3.96E+04 | 6.30E+03 | 0.00     | 9.84E+03 | 1.40E+06 | 7.74E+04 |
| Fe-55   | 2.46E+04 | 1.70E+04 | 3.94E+03 | 0.00     | 0.00     | 7.21E+04 | 6.03E+03 |
| Fe-59   | 1.18E+04 | 2.78E+04 | 1.06E+04 | 0.00     | 0.00     | 1.02E+06 | 1.88E+05 |
| Co-58   | 0.00     | 1.58E+03 | 2.07E+03 | 0.00     | 0.00     | 9.28E+05 | 1.06E+05 |
| Co-60   | 0.00     | 1.15E+04 | 1.48E+04 | 0.00     | 0.00     | 5.97E+06 | 2.85E+05 |
| Ni-63   | 4.32E+05 | 3.14E+04 | 1.45E+04 | 0.00     | 0.00     | 1.78E+05 | 1.34E+04 |
| Zn-65   | 3.24E+04 | 1.03E+05 | 4.66E+04 | 0.00     | 6.90E+04 | 8.64E+05 | 5.34E+04 |
| Rb-86   | 0.00     | 1.35E+05 | 5.90E+04 | 0.00     | 0.00     | 0.00     | 1.66E+04 |
| Sr-89   | 3.04E+05 | 0.00     | 8.72E+03 | 0.00     | 0.00     | 1.40E+06 | 3.50E+05 |
| Sr-90   | 9.92E+07 | 0.00     | 6.10E+06 | 0.00     | 0.00     | 9.60E+06 | 7.22E+05 |
| Y-91    | 4.62E+05 | 0.00     | 1.24E+04 | 0.00     | 0.00     | 1.70E+06 | 3.85E+05 |
| Zr-95   | 1.07E+05 | 3.44E+04 | 2.33E+04 | 0.00     | 5.42E+04 | 1.77E+06 | 1.50E+05 |
| Nb-95   | 1.41E+04 | 7.82E+03 | 4.21E+03 | 0.00     | 7.74E+03 | 5.05E+05 | 1.04E+05 |
| Ru-103  | 1.53E+03 | 0.00     | 6.58E+02 | 0.00     | 5.83E+03 | 5.05E+05 | 1.10E+05 |
| Ru-106  | 6.91E+04 | 0.00     | 8.72E+03 | 0.00     | 1.34E+05 | 9.36E+06 | 9.12E+05 |
| Ag-110m | 1.08E+04 | 1.00E+04 | 5.94E+03 | 0.00     | 1.97E+04 | 4.63E+06 | 3.02E+05 |
| Sb-124  | 3.12E+04 | 5.89E+02 | 1.24E+04 | 7.55E+01 | 0.00     | 2.48E+06 | 4.06E+05 |
| Sb-125  | 6.61E+04 | 7.13E+02 | 1.33E+04 | 5.87E+01 | 0.00     | 2.20E+06 | 1.01E+05 |
| Te-125m | 3.42E+03 | 1.58E+03 | 4.67E+02 | 1.05E+03 | 1.24E+04 | 3.14E+05 | 7.06E+04 |
| Te-127m | 1.26E+04 | 5.77E+03 | 1.57E+03 | 3.29E+03 | 4.58E+04 | 9.60E+05 | 1.50E+05 |
| Te-129m | 9.76E+03 | 4.67E+03 | 1.58E+03 | 3.44E+03 | 3.66E+04 | 1.16E+06 | 3.83E+05 |
| I-131   | 2.52E+04 | 3.58E+04 | 2.05E+04 | 1.19E+07 | 6.13E+04 | 0.00     | 6.28E+03 |
| I-133   | 8.64E+03 | 1.48E+04 | 4.52E+03 | 2.15E+06 | 2.58E+04 | 0.00     | 8.88E+03 |
| Cs-134  | 3.73E+05 | 8.48E+05 | 7.28E+05 | 0.00     | 2.87E+05 | 9.76E+04 | 1.04E+04 |
| Cs-136  | 3.90E+04 | 1.46E+05 | 1.10E+05 | 0.00     | 8.56E+04 | 1.20E+04 | 1.17E+04 |
| Cs-137  | 4.78E+05 | 6.21E+05 | 4.28E+05 | 0.00     | 2.22E+05 | 7.52E+04 | 8.40E+03 |
| Ba-140  | 3.90E+04 | 4.90E+01 | 2.57E+03 | 0.00     | 1.67E+01 | 1.27E+06 | 2.18E+05 |
| Ce-141  | 1.99E+04 | 1.35E+04 | 1.53E+03 | 0.00     | 6.26E+03 | 3.62E+05 | 1.20E+05 |
| Ce-144  | 3.43E+06 | 1.43E+06 | 1.84E+05 | 0.00     | 8.48E+05 | 7.78E+06 | 8.16E+05 |
| Pr-143  | 9.36E+03 | 3.75E+03 | 4.64E+02 | 0.00     | 2.16E+03 | 2.81E+05 | 2.00E+05 |
| Nd-147  | 5.27E+03 | 6.10E+03 | 3.65E+02 | 0.00     | 3.56E+03 | 2.21E+05 | 1.73E+05 |

1. Units are (mrem/yr)/( $\mu\text{Ci}/\text{m}^3$ ) for all radionuclides.
2. This table is included to support the calculations of section 6.2.

Table 3-11.  $R_{aij}$  for Cow Meat Pathway, Child Age Group

| Nuclide | Bone     | Liver    | T. Body  | Thyroid  | Kidney   | Lung     | GI-LLI   |
|---------|----------|----------|----------|----------|----------|----------|----------|
| H-3     | 0.00     | 2.34E+02 | 2.34E+02 | 2.34E+02 | 2.34E+02 | 2.34E+02 | 2.34E+02 |
| C-14    | 5.29E+05 | 1.06E+05 | 1.06E+05 | 1.06E+05 | 1.06E+05 | 1.06E+05 | 1.06E+05 |
| P-32    | 7.41E+09 | 3.47E+08 | 2.86E+08 | 0.00     | 0.00     | 0.00     | 2.05E+08 |
| Cr-51   | 0.00     | 0.00     | 8.79E+03 | 4.88E+03 | 1.33E+03 | 8.91E+03 | 4.66E+05 |
| Mn-54   | 0.00     | 8.01E+06 | 2.13E+06 | 0.00     | 2.25E+06 | 0.00     | 6.72E+06 |
| Fe-55   | 4.57E+08 | 2.42E+08 | 7.51E+07 | 0.00     | 0.00     | 1.37E+08 | 4.49E+07 |
| Fe-59   | 3.76E+08 | 6.09E+08 | 3.03E+08 | 0.00     | 0.00     | 1.77E+08 | 6.34E+08 |
| Co-58   | 0.00     | 1.64E+07 | 5.02E+07 | 0.00     | 0.00     | 0.00     | 9.58E+07 |
| Co-60   | 0.00     | 6.93E+07 | 2.04E+08 | 0.00     | 0.00     | 0.00     | 3.84E+08 |
| Ni-63   | 2.91E+10 | 1.56E+09 | 9.91E+08 | 0.00     | 0.00     | 0.00     | 1.05E+08 |
| Zn-65   | 3.75E+08 | 1.00E+09 | 6.22E+08 | 0.00     | 6.30E+08 | 0.00     | 1.76E+08 |
| Rb-86   | 0.00     | 5.77E+08 | 3.55E+08 | 0.00     | 0.00     | 0.00     | 3.71E+07 |
| Sr-89   | 4.82E+08 | 0.00     | 1.38E+07 | 0.00     | 0.00     | 0.00     | 1.87E+07 |
| Sr-90   | 1.04E+10 | 0.00     | 2.64E+09 | 0.00     | 0.00     | 0.00     | 1.40E+08 |
| Y-91    | 1.80E+06 | 0.00     | 4.82E+04 | 0.00     | 0.00     | 0.00     | 2.40E+08 |
| Zr-95   | 2.66E+06 | 5.85E+05 | 5.21E+05 | 0.00     | 8.38E+05 | 0.00     | 6.11E+08 |
| Nb-95   | 3.10E+06 | 1.21E+06 | 8.62E+05 | 0.00     | 1.13E+06 | 0.00     | 2.23E+09 |
| Ru-103  | 1.55E+08 | 0.00     | 5.96E+07 | 0.00     | 3.90E+08 | 0.00     | 4.01E+09 |
| Ru-106  | 4.44E+09 | 0.00     | 5.54E+08 | 0.00     | 5.99E+09 | 0.00     | 6.90E+10 |
| Ag-110m | 8.39E+06 | 5.67E+06 | 4.53E+06 | 0.00     | 1.06E+07 | 0.00     | 6.74E+08 |
| Sb-124  | 0.00     | 0.00     | 0.00     | 0.00     | 0.00     | 0.00     | 0.00     |
| Sb-125  | 0.00     | 0.00     | 0.00     | 0.00     | 0.00     | 0.00     | 0.00     |
| Te-125m | 5.69E+08 | 1.54E+08 | 7.59E+07 | 1.60E+08 | 0.00     | 0.00     | 5.49E+08 |
| Te-127m | 1.77E+09 | 4.78E+08 | 2.11E+08 | 4.24E+08 | 5.06E+09 | 0.00     | 1.44E+09 |
| Te-129m | 1.79E+09 | 5.00E+08 | 2.78E+08 | 5.77E+08 | 5.26E+09 | 0.00     | 2.18E+09 |
| I-131   | 1.65E+07 | 1.66E+07 | 9.46E+06 | 5.50E+09 | 2.73E+07 | 0.00     | 1.48E+06 |
| I-133   | 5.67E-01 | 7.02E-01 | 2.66E-01 | 1.30E+02 | 1.17E+00 | 0.00     | 2.83E-01 |
| Cs-134  | 9.22E+08 | 1.51E+09 | 3.19E+08 | 0.00     | 4.69E+08 | 1.68E+08 | 8.16E+06 |
| Cs-136  | 1.62E+07 | 4.46E+07 | 2.88E+07 | 0.00     | 2.37E+07 | 3.54E+06 | 1.57E+06 |
| Cs-137  | 1.33E+09 | 1.28E+09 | 1.88E+08 | 0.00     | 4.16E+08 | 1.50E+08 | 7.99E+06 |
| Ba-140  | 4.38E+07 | 3.84E+04 | 2.56E+06 | 0.00     | 1.25E+04 | 2.29E+04 | 2.22E+07 |
| Ce-141  | 2.22E+04 | 1.11E+04 | 1.64E+03 | 0.00     | 4.86E+03 | 0.00     | 1.38E+07 |
| Ce-144  | 2.32E+06 | 7.26E+05 | 1.24E+05 | 0.00     | 4.02E+05 | 0.00     | 1.89E+08 |
| Pr-143  | 3.34E+04 | 1.00E+04 | 1.66E+03 | 0.00     | 5.43E+03 | 0.00     | 3.60E+07 |
| Nd-147  | 1.17E+04 | 9.47E+03 | 7.33E+02 | 0.00     | 5.19E+03 | 0.00     | 1.50E+07 |

Units are (mrem/yr)/( $\mu\text{Ci}/\text{m}^3$ ) for tritium, and  $\text{m}^2 \cdot (\text{mrem}/\text{yr})/(\mu\text{Ci}/\text{s})$  for all other radionuclides.

Table 3-12.  $R_{aij}$  for Garden Vegetation Pathway, Child Age Group

| Nuclide | Bone     | Liver    | T.Body   | Thyroid  | Kidney   | Lung     | GI-LLI   |
|---------|----------|----------|----------|----------|----------|----------|----------|
| H-3     | 0.00     | 4.01E+03 | 4.01E+03 | 4.01E+03 | 4.01E+03 | 4.01E+03 | 4.01E+03 |
| C-14    | 8.89E+08 | 1.78E+08 | 1.78E+08 | 1.78E+08 | 1.78E+08 | 1.78E+08 | 1.78E+08 |
| P-32    | 3.37E+09 | 1.58E+08 | 1.30E+08 | 0.00     | 0.00     | 0.00     | 9.31E+07 |
| Cr-51   | 0.00     | 0.00     | 1.17E+05 | 6.50E+04 | 1.78E+04 | 1.19E+05 | 6.21E+06 |
| Mn-54   | 0.00     | 6.65E+08 | 1.77E+08 | 0.00     | 1.86E+08 | 0.00     | 5.58E+08 |
| Fe-55   | 8.01E+08 | 4.25E+08 | 1.32E+08 | 0.00     | 0.00     | 2.40E+08 | 7.87E+07 |
| Fe-59   | 3.98E+08 | 6.43E+08 | 3.20E+08 | 0.00     | 0.00     | 1.86E+08 | 6.70E+08 |
| Co-58   | 0.00     | 6.44E+07 | 1.97E+08 | 0.00     | 0.00     | 0.00     | 3.76E+08 |
| Co-60   | 0.00     | 3.78E+08 | 1.12E+09 | 0.00     | 0.00     | 0.00     | 2.10E+09 |
| Ni-63   | 3.95E+10 | 2.11E+09 | 1.34E+09 | 0.00     | 0.00     | 0.00     | 1.42E+08 |
| Zn-65   | 8.13E+08 | 2.16E+09 | 1.35E+09 | 0.00     | 1.36E+09 | 0.00     | 3.80E+08 |
| Rb-86   | 0.00     | 4.52E+08 | 2.78E+08 | 0.00     | 0.00     | 0.00     | 2.91E+07 |
| Sr-89   | 3.60E+10 | 0.00     | 1.03E+09 | 0.00     | 0.00     | 0.00     | 1.39E+09 |
| Sr-90   | 1.24E+12 | 0.00     | 3.15E+11 | 0.00     | 0.00     | 0.00     | 1.67E+10 |
| Y-91    | 1.86E+07 | 0.00     | 4.99E+05 | 0.00     | 0.00     | 0.00     | 2.48E+09 |
| Zr-95   | 3.86E+06 | 8.48E+05 | 7.55E+05 | 0.00     | 1.21E+06 | 0.00     | 8.85E+08 |
| Nb-95   | 4.10E+05 | 1.60E+05 | 1.14E+05 | 0.00     | 1.50E+05 | 0.00     | 2.96E+08 |
| Ru-103  | 1.53E+07 | 0.00     | 5.90E+06 | 0.00     | 3.86E+07 | 0.00     | 3.97E+08 |
| Ru-106  | 7.45E+08 | 0.00     | 9.30E+07 | 0.00     | 1.01E+09 | 0.00     | 1.16E+10 |
| Ag-110m | 3.21E+07 | 2.17E+07 | 1.73E+07 | 0.00     | 4.04E+07 | 0.00     | 2.58E+09 |
| Sb-124  | 0.00     | 0.00     | 0.00     | 0.00     | 0.00     | 0.00     | 0.00     |
| Sb-125  | 0.00     | 0.00     | 0.00     | 0.00     | 0.00     | 0.00     | 0.00     |
| Te-125m | 3.51E+08 | 9.50E+07 | 4.67E+07 | 9.84E+07 | 0.00     | 0.00     | 3.38E+08 |
| Te-127m | 1.32E+09 | 3.56E+08 | 1.57E+08 | 3.16E+08 | 3.77E+09 | 0.00     | 1.07E+09 |
| Te-129m | 8.41E+08 | 2.35E+08 | 1.31E+08 | 2.71E+08 | 2.47E+09 | 0.00     | 1.03E+09 |
| I-131   | 1.43E+08 | 1.44E+08 | 8.17E+07 | 4.75E+10 | 2.36E+08 | 0.00     | 1.28E+07 |
| I-133   | 3.53E+06 | 4.37E+06 | 1.65E+06 | 8.11E+08 | 7.28E+06 | 0.00     | 1.76E+06 |
| Cs-134  | 1.60E+10 | 2.63E+10 | 5.55E+09 | 0.00     | 8.15E+09 | 2.93E+09 | 1.42E+08 |
| Cs-136  | 8.24E+07 | 2.27E+08 | 1.47E+08 | 0.00     | 1.21E+08 | 1.80E+07 | 7.96E+06 |
| Cs-137  | 2.39E+10 | 2.29E+10 | 3.38E+09 | 0.00     | 7.46E+09 | 2.68E+09 | 1.43E+08 |
| Ba-140  | 2.77E+08 | 2.42E+05 | 1.61E+07 | 0.00     | 7.89E+04 | 1.45E+05 | 1.40E+08 |
| Ce-141  | 6.56E+05 | 3.27E+05 | 4.86E+04 | 0.00     | 1.43E+05 | 0.00     | 4.08E+08 |
| Ce-144  | 1.27E+08 | 3.98E+07 | 6.78E+06 | 0.00     | 2.21E+07 | 0.00     | 1.04E+10 |
| Pr-143  | 1.46E+05 | 4.37E+04 | 7.23E+03 | 0.00     | 2.37E+04 | 0.00     | 1.57E+08 |
| Nd-147  | 7.15E+04 | 5.79E+04 | 4.48E+03 | 0.00     | 3.18E+04 | 0.00     | 9.17E+07 |

Units are (mrem/yr)/( $\mu$ Ci/m<sup>3</sup>) for tritium, and m<sup>2</sup>·(mrem/yr)/( $\mu$ Ci/s) for all other radionuclides.

3.5 GASEOUS EFFLUENT DOSE PROJECTIONS

3.5.1 Thirty-One Day Dose Projections

In order to meet the requirements of the limit for operation of the gaseous radwaste treatment system (see Section 3.1.5), dose projections must be made at least once each 31 days; this applies during periods in which a discharge to areas at or beyond the SITE BOUNDARY of gaseous effluents containing radioactive materials occurs or is expected.

Projected 31–day air doses and doses to individuals due to gaseous effluents may be determined as follows:

For air doses:

$$D_{\beta p} = \left( \frac{D_{\beta c}}{t} \right) \times 31 + D_{\beta a} \tag{3.16}$$

$$D_{\gamma p} = \left( \frac{D_{\gamma c}}{t} \right) \times 31 + D_{\gamma a}$$

For individual doses:

$$D_{op} = \left( \frac{D_{oc}}{t} \right) \times 31 + D_{oa} \tag{3.17}$$

where:

- $D_{\beta p}$  = the projected air dose due to beta emissions from noble gases, for the next 31 days of gaseous releases.
- $D_{\beta c}$  = the cumulative air dose due to beta emissions from noble gas releases that have occurred in the elapsed portion of the current quarter, plus the release under consideration.
- $D_{\beta a}$  = the anticipated air dose due to beta emissions from noble gas releases, contributed by any planned activities during the next 31–day period, if those activities will result in gaseous releases that are in addition to routine gaseous effluents. If only routine gaseous effluents are anticipated,  $D_{\beta a}$  may be set to zero.
- $D_{\gamma p}$  = the projected air dose due to gamma emissions from noble gases for the next 31 days of gaseous releases.
- $D_{\gamma c}$  = the cumulative air dose due to gamma emissions from noble gas releases that have occurred in the elapsed portion of the current quarter, plus the release under consideration.
- $D_{\gamma a}$  = the anticipated air dose due to gamma emissions from noble gas releases, contributed by any planned activities during the next 31–day period, if those activities will result in gaseous releases that are in addition to routine gaseous effluents. If only routine gaseous effluents are anticipated,  $D_{\gamma a}$  may be set to zero.

- 
- $D_{op}$  = the projected dose to the total body or organ o, due to releases of I-131, I-133, tritium, and particulates for the next 31 days of gaseous releases.
- $D_{oc}$  = the cumulative dose to the total body or organ o, due to releases of I-131, I-133, tritium, and particulates that have occurred in the elapsed portion of the current quarter, plus the release under consideration.
- $D_{oa}$  = the anticipated dose to the total body or organ o, due to releases of I-131, I-133, tritium, and particulates, contributed by any planned activities during the next 31-day period, if those activities will result in gaseous releases that are in addition to routine gaseous effluents. If only routine gaseous effluents are anticipated,  $D_{oa}$  may be set to zero.
- t = the number of whole or partial days elapsed into the current quarter, including the time to the end of the release under consideration (even if the release continues into the next quarter).

### 3.5.2 Dose Projections for Specific Releases

Dose projections may be performed for a particular release by performing a pre-release dose calculation assuming that the planned release will proceed as anticipated. For air dose and individual dose projections due to gaseous effluent releases, follow the methodology of Section 3.4, using sample analysis results for the gaseous stream to be released, and parameter values expected to exist during the release period.

## 3.6 DEFINITIONS OF GASEOUS EFFLUENT TERMS

| <u>Term</u>                        | <u>Definition</u>  | <u>Section of Initial Use</u> |
|------------------------------------|--|-------------------------------|
| AG =                               | the administrative allocation factor for gaseous streams, applied to divide the gaseous release limit among all the release pathways [unitless].   | 3.3.2.1                       |
| AG <sub>s</sub> =                  | the administrative allocation factor for gaseous source stream s, applied to divide the gaseous release limit among all the release pathways [unitless].                                     | 3.3.3                         |
| AG <sub>v</sub> =                  | the administrative allocation factor for gaseous release pathway v, applied to divide the gaseous release limit among all the release pathways [unitless].                                   | 3.3.2.2                       |
| c =                                | the setpoint of the radioactivity monitor measuring the concentration of radioactivity in the effluent line prior to release [ $\mu\text{Ci}/\text{mL}$ ].                                   | 3.3.2.1                       |
| c <sub>ns</sub> =                  | the calculated noble gas effluent monitor setpoint for gaseous source stream s [ $\mu\text{Ci}/\text{mL}$ ].   | 3.3.3                         |
| c <sub>nv</sub> =                  | the calculated noble gas effluent monitor setpoint for release pathway v [ $\mu\text{Ci}/\text{mL}$ ].   | 3.3.2.2                       |
| D <sub>ja</sub> =                  | the dose to organ j of an individual in age group a, due to gaseous releases of I-131, I-133, tritium, and radionuclides in particulate form with half-lives greater than 8 days [mrem].     | 3.4.3                         |
| D <sub>oa</sub> =                  | the anticipated dose to organ o due to releases of non-noble-gas radionuclides, contributed by any planned activities during the next 31-day period [mrem].                                  | 3.5.1                         |
| D <sub>oc</sub> =                  | the cumulative dose to organ o due to releases of non-noble-gas radionuclides that have occurred in the elapsed portion of the current quarter, plus the release under consideration [mrem]. | 3.5.1                         |
| D <sub>op</sub> =                  | the projected dose to organ o due to the next 31 days of gaseous releases of non-noble-gas radionuclides [mrem].   | 3.5.1                         |
| D <sub><math>\beta</math></sub> =  | the air dose due to beta emissions from noble gas radionuclides [mrad].  | 3.4.2                         |
| D <sub><math>\beta</math>a</sub> = | the anticipated air dose due to beta emissions from noble gas releases, contributed by any planned activities during the next 31-day period [mrad].  | 3.5.1                         |
| D <sub><math>\beta</math>c</sub> = |  |                               |

| <u>Term</u>               | <u>Definition</u>   | <u>Section of Initial Use</u> |
|---------------------------|---|-------------------------------|
|                           | the cumulative air dose due to beta emissions from noble gas releases that have occurred in the elapsed portion of the current quarter, plus the release under consideration [mrad].  | 3.5.1                         |
| $D_{\beta p} =$           | the projected air dose due to beta emissions from noble gases, for the next 31 days of gaseous releases [mrad].   | 3.5.1                         |
| $D_{\gamma} =$            | the air dose due to gamma emissions from noble gas radionuclides [mrad].  | 3.4.2                         |
| $D_{\gamma a} =$          | the anticipated air dose due to gamma emissions from noble gas releases, contributed by any planned activities during the next 31-day period [mrad].                                  | 3.5.1                         |
| $D_{\gamma c} =$          | the cumulative air dose due to gamma emissions from noble gas releases that have occurred in the elapsed portion of the current quarter, plus the release under consideration [mrad]. | 3.5.1                         |
| $D_{\gamma p} =$          | the projected air dose due to gamma emissions from noble gases, for the next 31 days of gaseous releases [mrad].  | 3.5.1                         |
| $(\overline{D/Q})_{vp} =$ | the annual average relative deposition factor for release pathway v, at the location of the controlling receptor, from Table 3-7 [ $m^{-2}$ ].  | 3.4.3                         |
| $DR_k =$                  | the skin dose rate at the time of the release [mrem/y].   | 3.4.1.1                       |
| $DR_o =$                  | the dose rate to organ o at the time of the release [mrem/y].   | 3.4.1.2                       |
| $DR_t =$                  | the total body dose rate at the time of the release [mrem/y].   | 3.4.1.1                       |
| $f_{av} =$                | the maximum anticipated actual discharge flowrate for release pathway v during the period of the planned release [mL/s].  | 3.3.2.2                       |
| $f_{as} =$                | the maximum anticipated actual discharge flowrate for gaseous source stream s during the period of the planned release [mL/s].  | 3.3.3                         |
| $K_i =$                   | the total body dose factor due to gamma emissions from noble gas radionuclide i, from Table 3-5 [(mrem/y)/( $\mu\text{Ci}/m^3$ )].  | 3.3.2.2                       |
| $L_i =$                   | the skin dose factor due to beta emissions from noble gas radionuclide i, from Table 3-5 [(mrem/y)/( $\mu\text{Ci}/m^3$ )].   | 3.3.2.2                       |
| $M_i =$                   | the air dose factor due to gamma emissions from noble gas radionuclide i, from Table 3-5 [(mrad/y)/( $\mu\text{Ci}/m^3$ )].   | 3.4.2                         |

| <u>Term</u>         | <u>Definition</u>  | <u>Section of Initial Use</u> |
|---------------------|--|-------------------------------|
| $N =$               | the number of simultaneously active gaseous release pathways [unitless].   | 3.3.4                         |
| $N_i =$             | the air dose factor due to beta emissions from noble gas radionuclide $i$ , from Table 3-5 [(mrad/y)/( $\mu\text{Ci}/\text{m}^3$ )].   | 3.4.2                         |
| $P_{io} =$          | the site-specific dose factor for radionuclide $i$ (I-131, I-133, tritium, and radionuclides in particulate form with half-lives greater than 8 days) and organ $o$ . The values of $P_{io}$ are equal to the site-specific $R_{aipj}$ values presented in Table 3-9 [(mrem/y)/( $\mu\text{Ci}/\text{m}^3$ )]. | 3.4.1.2                       |
| $Q_{iv} =$          | the release rate of noble gas radionuclide $i$ from release pathway $v$ during the period of interest [ $\mu\text{Ci}/\text{s}$ ].   | 3.3.2.2                       |
| $Q'_{iv} =$         | the release rate of radionuclide $i$ (I-131, I-133, tritium, and radionuclides in particulate form with half-lives greater than 8 days) from gaseous release pathway $v$ during the period of interest [ $\mu\text{Ci}/\text{s}$ ].  | 3.4.1.2                       |
| $\tilde{Q}_{iv} =$  | the cumulative release of noble gas radionuclide $i$ from release pathway $v$ during the period of interest [ $\mu\text{Ci}$ ].  | 3.4.2                         |
| $\tilde{Q}'_{iv} =$ | the cumulative release of non-noble-gas radionuclide $i$ from release pathway $v$ , during the period of interest [ $\mu\text{Ci}$ ].  | 3.4.3                         |
| $R_{aipj} =$        | the site-specific dose factor for age group $a$ , radionuclide $i$ , exposure pathway $p$ , and organ $j$ . Values and units of $R_{aipj}$ for each exposure pathway, age group, and radionuclide that may arise in calculations for implementing Section 3.1.4 are listed in Table 3-8 through Table 3-9.     | 3.4.3                         |
| $R_k =$             | the ratio of the skin dose rate limit for noble gases, to the skin dose rate due to noble gases in the release under consideration [unitless].   | 3.3.2.1                       |
| $R_t =$             | the ratio of the total body dose rate limit for noble gases, to the total body dose rate due to noble gases in the release under consideration [unitless].   | 3.3.2.1                       |
| $r_k =$             | the ratio of the skin dose rate limit for noble gases, to the skin dose rate due to noble gases in the source stream under consideration [unitless].   | 3.3.3.1                       |
| $r_t =$             | the ratio of the total body dose rate limit for noble gases, to the total body dose rate due to noble gases in the source stream under consideration [unitless].   | 3.3.3.1                       |

| <u>Term</u>    | <u>Definition</u>   | <u>Section of Initial Use</u> |
|----------------|---|-------------------------------|
| SF =           | the safety factor used in gaseous setpoint calculations to compensate for statistical fluctuations and errors of measurement [unitless].  | 3.3.2.2                       |
| t =            | the number of whole or partial days elapsed in the current quarter, including the period of the release under consideration.  | 3.5.1                         |
| $W_{vip} =$    | the annual average relative dispersion [ $(X/Q)_{vp}$ ] or deposition [ $(D/Q)_{vp}$ ] at the location of the controlling receptor, for release pathway v, as appropriate to exposure pathway p and radionuclide i. | 3.4.3                         |
| X =            | the noble gas concentration for the release under consideration [ $\mu\text{Ci/mL}$ ].  | 3.3.2.1                       |
| $X_{ir} =$     | the concentration of radionuclide i applicable to active gaseous release pathway r [ $\mu\text{Ci/mL}$ ].   | 3.3.4                         |
| $X_{is} =$     | the measured concentration of radionuclide i in gaseous source stream s [ $\mu\text{Ci/mL}$ ].  | 3.3.3                         |
| $X_{iv} =$     | the measured concentration of radionuclide i in gaseous stream v [ $\mu\text{Ci/mL}$ ].   | 3.3.2.2                       |
| $(X/Q) =$      | the highest relative concentration at any point at or beyond the SITE BOUNDARY [ $\text{s/m}^3$ ].  | 3.3.2.1                       |
| $(X/Q)_{rb} =$ | the annual average SITE BOUNDARY relative concentration applicable to active gaseous release pathway r [ $\text{s/m}^3$ ].  | 3.3.4                         |
| $(X/Q)_{vb} =$ | the highest annual average relative concentration at the SITE BOUNDARY for the discharge point of release pathway v, from Table 3-4 [ $\text{s/m}^3$ ].   | 3.3.2.2                       |

CHAPTER 4  
RADIOLOGICAL ENVIRONMENTAL MONITORING PROGRAM

4.1 LIMITS OF OPERATION

The following limits are the same for both VEGP units 1 and 2 and VEGP units 3 and 4 at the VEGP site. Thus, a single program including monitoring, land use survey, and quality assurance serves all four units.

4.1.1 Radiological Environmental Monitoring

The Radiological Environmental Monitoring Program (REMP) shall be conducted as specified in Table 4-1.

4.1.1.1 Applicability

This control applies at all times.

4.1.1.2 Actions

4.1.1.2.1 With the REMP not being conducted as specified in Table 4-1, submit to the Nuclear Regulatory Commission (NRC), in the Annual Radiological Environmental Operating Report, a description of the reasons for not conducting the program as required and the plans for preventing a recurrence. Deviations from the required sampling schedule are permitted if specimens are unobtainable due to hazardous conditions, unavailability, inclement weather, equipment malfunction, or other just reasons. If deviations are due to equipment malfunction, efforts shall be made to complete corrective action prior to the end of the next sampling period.

4.1.1.2.2 With the confirmed<sup>1</sup> measured level of radioactivity as a result of plant effluents in an environmental sampling medium specified in Table 4-1 exceeding the reporting levels of Table 4-2 when averaged over any calendar quarter, submit within 30 days a special report to the NRC. The special report shall identify the cause(s) for exceeding the limit(s) and define the corrective action(s) to be taken to reduce radioactive effluents so that the potential annual dose to a MEMBER OF THE PUBLIC is less than the calendar year limits of Sections 2.1.3, 3.1.3, and 3.1.4. The methodology and parameters used to estimate the potential annual dose to a MEMBER OF THE PUBLIC shall be indicated in the special report.

When more than one of the radionuclides in Table 4-2 are detected in the sampling medium, this report shall be submitted if:

$$\frac{\text{concentration (1)}}{\text{reporting level (1)}} + \frac{\text{concentration (2)}}{\text{reporting level (2)}} + \dots \geq 1.0$$

When radionuclides other than those in Table 4-2 are detected and are the result of plant effluents, this special report shall be submitted if the potential annual dose to a MEMBER OF THE

<sup>1</sup> Defined as confirmed by reanalysis of the original sample, or analysis of a duplicate or new sample, as appropriate. The results of the confirmatory analysis shall be completed at the earliest time consistent with the analysis.

---

PUBLIC is equal to or greater than the calendar year limits stated in Sections 2.1.3, 3.1.3, and 3.1.4. This special report is not required if the measured level of radioactivity was not the result of plant effluents; however, in such an event, the condition shall be described in the Annual Radiological Environmental Operating Report. The levels of naturally-occurring radionuclides which are not included in the plant's effluent releases need not be reported.

4.1.1.2.3 If adequate samples of milk, or during the growing season, grass or leafy vegetation, can no longer be obtained from one or more of the sample locations required by Table 4-1, or if the availability is frequently or persistently wanting, efforts shall be made: to identify specific locations for obtaining suitable replacement samples; and to add any replacement locations to the REMP given in the ODCM within 30 days. The specific locations from which samples became unavailable may be deleted from the REMP. Pursuant to Technical Specification 5.5.1, documentation shall be submitted in the next Radioactive Effluent Release Report for the change(s) in the ODCM, including revised figure(s) and table(s) reflecting the changes to the location(s), with supporting information identifying the cause of the unavailability of samples and justifying the selection of any new location(s).

4.1.1.2.4 This control does not affect shutdown requirements or MODE changes.

#### 4.1.1.3 Surveillance Requirements

The REMP samples shall be collected pursuant to Table 4-1 from the locations described in Section 4.2, and shall be analyzed pursuant to the requirements of Table 4-1 and Table 4-3. Required detection capabilities for thermoluminescent dosimeters used for environmental measurements shall be in accordance with the recommendations of Regulatory Guide 4.13. Program changes may be initiated based on operational experience.

Analyses shall be performed in such a manner that the stated MINIMUM DETECTABLE CONCENTRATIONS (MDCs) will be achieved under routine conditions. Occasionally background fluctuations, unavoidable small sample sizes, the presence of interfering radionuclides, or other uncontrollable circumstances may render these MDCs unachievable. In such cases, the contributing factors will be identified and described in the Annual Radiological Environmental Operating Report.

#### 4.1.1.4 Basis

The REMP required by this control provides representative measurements of radiation and of radioactive materials in those exposure pathways, and for those radionuclides, which lead to the highest potential radiation exposures of MEMBERS OF THE PUBLIC resulting from the plant operation. The REMP implements Section IV.B.2, Appendix I, 10 CFR 50, and thereby supplements the radiological effluent monitoring program by measuring concentrations of radioactive materials and levels of radiation, which may then be compared with those expected on the basis of the effluent measurements and modeling of the environmental exposure pathways.

The detection capabilities required by Table 4-3 are within state-of-the-art for routine environmental measurements in industrial laboratories.

Table 4-1. Radiological Environmental Monitoring Program

| Exposure Pathway and/or Sample  | Number of Representative Samples and Sample Locations <sup>(1)</sup>  | Sampling and Collection Frequency   | Type and Frequency of Analysis   |
|---------------------------------|---|---|--|
| <b>1. DIRECT RADIATION</b>      |   |   |  |
| Direct Radiation <sup>(2)</sup> | <p>Thirty-six or more routine monitoring stations, either with two or more dosimeters, or with one instrument for measuring and recording dose rate continuously, placed as follows:</p> <p>An inner ring of 16 stations, one in each meteorological sector in the general area of the site boundary.</p> <p>An outer ring of 16 stations, one in each meteorological sector at approximately 4-8 miles from the site.</p> <p>The balance of the stations to be placed in special interest areas such as population centers, nearby residences, or schools.</p> | Quarterly.  | Gamma dose quarterly.  |
| <b>2. AIRBORNE</b>              |   |   |  |
| Radioiodine and Particulates    | <p>Samples from 4 or more locations as follows:</p> <p>Three samples from close to the three site boundary locations, in highest calculated annual average ground-level D/Q sectors.</p> <p>One sample from the vicinity of a community having the highest calculated annual average ground-level D/Q.</p>  | Continuous sampler operation with sample collection weekly, or more frequently if required by dust loading. | <p><u>Radioiodine Canister</u>: I-131 analysis weekly.</p> <p><u>Particulate Sampler</u>: Gross beta radioactivity analysis following filter change,<sup>(3)</sup> and gamma isotopic analysis of composite (by location) quarterly.<sup>(4)</sup></p> |
| <b>3. WATERBORNE</b>            |   |   |  |
| Surface <sup>(5)</sup>          | <p>One sample upstream.</p> <p>One sample downstream.</p>   | Composite sample over 1-month period. <sup>(6)</sup>  | Gamma isotopic analysis monthly; composite for tritium analysis quarterly. <sup>(4)</sup>  |

Table 4-1. Radiological Environmental Monitoring Program

| Exposure Pathway and/or Sample | Number of Representative Samples and Sample Locations <sup>(1)</sup>  | Sampling and Collection Frequency  | Type and Frequency of Analysis  |
|--------------------------------|---|--|---|
| Drinking                       | <p>Two samples at each of the one to three nearest water treatment plants that could be affected by discharges from the facility.</p> <p>Two samples at a control location.</p>   | <p>Composite sample of river water near intake at each water treatment plant over 2-week period when I-131 analysis is performed, monthly composite otherwise; and grab sample of finished water at each water treatment plant every 2 weeks or monthly, as appropriate.<sup>(6)</sup></p> | <p>I-131 analysis on each sample when the dose calculated for the consumption of the water is greater than 1 mrem per year.<sup>(7)</sup></p> <p>Composite for gross beta and gamma isotopic analyses monthly.<sup>(4)</sup></p> <p>Composite for tritium analysis quarterly.</p> |
| Sediment from Shoreline        | <p>One sample from downstream area with existing or potential recreational value.</p>   | <p>Semiannually.</p>   | <p>Gamma isotopic analysis semi-annually.<sup>(4)</sup></p>   |
| Groundwater                    | <p>On-site groundwater monitoring is not required at Vogtle per NUREG 1301. Groundwater monitoring is performed under NMP-EN-002.</p>   | <p>See NMP-EN-002.</p>   | <p>See NMP-EN-002.</p>  |
| 4. INGESTION                   |   |  |   |
| Milk                           | <p>Samples from milking animals in three locations within 3 miles distance having the highest dose potential; if there are none, then one sample from milking animals in each of three areas between 3 and 5 miles distance where doses are calculated to be greater than 1 mrem per year.<sup>(7)</sup></p> <p>One sample from milking animals at a control location about 10 miles distant or beyond, and preferably in a wind direction of low prevalence.</p> | <p>Semimonthly.</p>  | <p>Gamma isotopic analysis semi-monthly.<sup>(4)(8)</sup></p>   |

Table 4-1. Radiological Environmental Monitoring Program

| Exposure Pathway and/or Sample | Number of Representative Samples and Sample Locations <sup>(1)</sup>  | Sampling and Collection Frequency                          | Type and Frequency of Analysis                             |
|--------------------------------|---|--|--|
| Fish                           | <p>One sample of any commercially and recreationally important species (e.g., bass, sunfish, catfish) in vicinity of plant discharge area.</p> <p>One sample of the same species in areas not influenced by plant discharge.</p> <p>At least one sample of any anadromous species in vicinity of plant discharge.</p> | <p>Semiannually.</p> <p>During spring spawning season.</p> | Gamma isotopic analyses on edible portions. <sup>(4)</sup> |
| Grass or Leafy Vegetation      | <p>One sample from two onsite locations near the site boundary in different sectors.</p> <p>One sample from a control location about 15 miles distant.</p>  | Monthly during growing season.                             | Gamma isotopic. <sup>(4)(8)</sup>                          |

Table 4-1. Radiological Environmental Monitoring Program

**TABLE NOTATIONS**

- (1) This is a common program with Vogtle units 3 and 4. For each sample location in this table, specific parameters of distance and direction sector from a point midway between the center of the two reactors for Vogtle units 1 and 2 and Vogtle units 3 and 4. Pertinent information of this program can be found in Table 4-4 and in Figure 4-1 through Figure 4-4 of this ODCM.
- (2) One or more instruments, such as a pressurized ion chamber, for measuring and recording dose rate continuously, may be used in place of or in addition to integrating dosimeters. For the purpose of this table, an optically stimulated luminescent dosimeter (OSLD) is considered to be one phosphor; two or more phosphors in a packet are considered as two or more dosimeters. Film badges shall not be used as dosimeters for measuring direct radiation.
- (3) Airborne particulate sample filters shall be analyzed for gross beta radioactivity 24 hours or more after sampling to allow for radon and thoron daughter decay. If gross beta activity in air particulate samples is greater than 200 fCi/m<sup>3</sup>, gamma isotopic analysis shall be performed on the individual samples.
- (4) Gamma isotopic analysis means the identification and quantification of gamma-emitting radionuclides that may be attributable to the effluents from the facility.
- (5) The upstream sample shall be taken at a distance beyond significant influence of the discharge. The downstream sample shall be taken in an area beyond but near the mixing zone.
- (6) Composite sample aliquots shall be collected at time intervals that are very short (e.g., hourly) relative to the compositing period (e.g., monthly) in order to assure obtaining a representative sample.
- (7) The dose shall be calculated for the maximum organ and age group, using the methodology and parameters in the ODCM.
- (8) If gamma isotopic analysis is not sensitive enough to meet the required MDC for I-131, a separate analysis for I-131 will be performed.

Table 4-2. Reporting Levels for Radioactivity Concentrations in Environmental Samples

| Analysis | Water<br>(pCi/L)   | Airborne<br>Particulate or<br>Gases (pCi/m <sup>3</sup> ) | Fish<br>(pCi/kg, wet) | Milk<br>(pCi/L) | Grass or Leafy<br>Vegetation<br>(pCi/kg, wet) |
|----------|--------------------|---|-----------------------|-----------------|---|
| H-3      | 2 E+4 <sup>a</sup> |   |                       |                 |   |
| Mn-54    | 1 E+3              |   | 3 E+4                 |                 |   |
| Fe-59    | 4 E+2              |   | 1 E+4                 |                 |   |
| Co-58    | 1 E+3              |   | 3 E+4                 |                 |   |
| Co-60    | 3 E+2              |   | 1 E+4                 |                 |   |
| Zn-65    | 3 E+2              |   | 2 E+4                 |                 |   |
| Zr-95    | 4 E+2              |   |                       |                 |   |
| Nb-95    | 7 E+2              |   |                       |                 |   |
| I-131    | 2 E+0 <sup>b</sup> | 9 E-1   |                       | 3 E+0           | 1 E+2   |
| Cs-134   | 3 E+1              | 1 E+1   | 1 E+3                 | 6 E+1           | 1 E+3   |
| Cs-137   | 5 E+1              | 2 E+1   | 2 E+3                 | 7 E+1           | 2 E+3   |
| Ba-140   | 2 E+2              |   |                       | 3 E+2           |   |
| La-140   | 1 E+2              |   |                       | 4 E+2           |   |

- a. This is the 40 CFR 141 value for drinking water samples. If no drinking water pathway exists, a value of 3 E+04 pCi/L may be used.
- b. If no drinking water pathway exists, a value of 20 pCi/L may be used.

Table 4-3. Values for the Minimum Detectable Concentration (MDC)

| Analysis     | Minimum Detectable Concentration (MDC) <sup>a</sup> |   |                    |              |   |                        |
|--------------|---|---|--------------------|--------------|---|------------------------|
|              | Water (pCi/L)                                       | Airborne Particulate or Gases (pCi/m <sup>3</sup> ) | Fish (pCi/kg, wet) | Milk (pCi/L) | Grass or Leafy Vegetation (pCi/kg, wet) | Sediment (pCi/kg, dry) |
| Gross Beta   | 4 E+0   | 1 E-2   |                    |              |   |                        |
| H-3          | 2 E+3 <sup>b</sup>                                  |   |                    |              |   |                        |
| Mn-54        | 1.5 E+1   |   | 1.3 E+2            |              |   |                        |
| Fe-59        | 3 E+1   |   | 2.6 E+2            |              |   |                        |
| Co-58, Co-60 | 1.5 E+1   |   | 1.3 E+2            |              |   |                        |
| Zn-65        | 3 E+1   |   | 2.6 E+2            |              |   |                        |
| Zr-95        | 3 E+1   |   |                    |              |   |                        |
| Nb-95        | 1.5 E+1   |   |                    |              |   |                        |
| I-131        | 1 E+0 <sup>c</sup>                                  | 7 E-2   |                    | 1 E+0        | 6 E+1                                   |                        |
| Cs-134       | 1.5 E+1   | 5 E-2   | 1.3 E+2            | 1.5 E+1      | 6 E+1                                   | 1.5 E+2                |
| Cs-137       | 1.8 E+1   | 6 E-2   | 1.5 E+2            | 1.8 E+1      | 8 E+1                                   | 1.8 E+2                |
| Ba-140       | 6 E+1   |   |                    | 6 E+1        |   |                        |
| La-140       | 1.5 E+1   |   |                    | 1.5 E+1      |   |                        |

- a. See the definition of MINIMUM DETECTABLE CONCENTRATION in Section 10.1. Other peaks which are measurable and identifiable as plant effluents, together with the radionuclides in this table, shall be analyzed and reported in accordance with Section 7.1.
- b. If no drinking water pathway exists, a value of 3 E+3 pCi/L may be used.
- c. If no drinking water pathway exists, a value of 1.5 E+1 pCi/L may be used.

#### 4.1.2 Land Use Census

A land use census shall be conducted and shall identify the following within a distance of 5 miles in each of the 16 meteorological sectors: the location of the nearest milk animal,<sup>1</sup> the nearest permanent residence, and the nearest garden of greater than 500 square feet producing broad leafy vegetation. Land within the Savannah River Site is excluded from this census.

##### 4.1.2.1 Applicability

This control applies at all times.

##### 4.1.2.2 Actions

4.1.2.2.1 With a land use census identifying a location(s) which yields a calculated dose or dose commitment greater than values currently being calculated in accordance with Section 3.4.3, identify the new location(s) in the next Radioactive Effluent Release Report.

4.1.2.2.2 With a land use census identifying a location(s) which yields a calculated dose or dose commitment (via the same exposure pathway) 20 percent greater than at a location from which samples are currently being obtained in accordance with Section 4.1.1, add the new location(s) to the REMP within 30 days if samples are available. The sampling location, excluding control station location(s), having the lowest calculated dose or dose commitment (via the same exposure pathway) may be deleted from the REMP if new sampling locations are added. Pursuant to Technical Specification 5.5.1 submit in the next Radioactive Effluent Release Report any change(s) in the ODCM, including the revised figure(s) and table(s) reflecting any new location(s) and information supporting the change(s).

4.1.2.2.3 This control does not affect shutdown requirements or MODE changes.

##### 4.1.2.3 Surveillance Requirements

The land use census shall be conducted annually, using that information which will provide good results, such as a door-to-door census, a visual census from automobile or aircraft, consultation with local agriculture authorities, or some combination of these methods, as feasible. Results of the land use census shall be included in the Annual Radiological Environmental Operating Report.

##### 4.1.2.4 Basis

This control is provided to ensure that changes in the use of UNRESTRICTED AREAS are identified and that modifications to the REMP are made if required by the results of this census. This census satisfies the requirements of Section IV.B.3 of Appendix I to 10 CFR Part 50. Restricting the census to gardens of greater than 500 ft<sup>2</sup> provides assurance that significant exposure pathways via leafy vegetables will be identified and monitored since a garden of this size is the minimum required to produce the quantity (26 kg/y) of leafy vegetables assumed in Regulatory Guide 1.109 for consumption by a child. To determine this minimum garden size, the following assumptions were made: (1) 20 percent of the garden was used for growing broad leaf vegetation (i.e., similar to lettuce and cabbage) and (2) a vegetation yield of 2 kg/m<sup>2</sup> was obtained.

<sup>1</sup> Defined as a cow or goat that is producing milk for human consumption.

---

### 4.1.3 Interlaboratory Comparison Program

Analyses shall be performed on radioactive materials supplied as part of an Interlaboratory Comparison Program which satisfies the requirements of Regulatory Guide 4.15, Revision 1, February, 1979.

#### 4.1.3.1 Applicability

This control applies at all times.

#### 4.1.3.2 Actions

With analyses not being performed as required by Section 4.1.3, report the corrective actions taken to prevent a recurrence in the Annual Radiological Environmental Operating Report.

This control does not affect shutdown requirements or MODE changes.

#### 4.1.3.3 Surveillance Requirements

A summary of the results obtained as part of the required Interlaboratory Comparison Program shall be included in the Annual Radiological Environmental Operating Report.

#### 4.1.3.4 Basis

The requirement for participation in an approved Interlaboratory Comparison Program is provided to ensure that independent checks on the precision and accuracy of the measurements of radioactive material in environmental sample matrices are performed as part of the quality assurance program for environmental monitoring, in order to demonstrate that the results are reasonably valid for the purposes of Section IV.B.2, Appendix I, 10 CFR 50.

---

## 4.2 RADIOLOGICAL ENVIRONMENTAL MONITORING LOCATIONS

Table 4-4 and Figure 4-1 through Figure 4-4 specify the locations at which the measurements and samples are taken for the REMP required by Section 4.1.1.

Table 4-4. Radiological Environmental Monitoring Locations

| Location Number         | Descriptive Location  | Latitude  | Longitude  | Units 1 and 2 |                  | Units 3 and 4 |                  | Sample Type <sup>(1)</sup> |
|-------------------------|-----------------------|-----------|------------|---------------|------------------|---------------|------------------|----------------------------|
|                         |                       |           |            | Direction     | Distance (miles) | Direction     | Distance (miles) |                            |
| OSLD Site Boundary Ring |                       |           |            |               |                  |               |                  |                            |
| 1                       | River Bank            | 33.158196 | -81.763205 | N             | 1.1              | NNE           | 1.2              | D                          |
| 2                       | River Bank            | 33.152146 | -81.756462 | NNE           | 0.8              | NE            | 1.2              | D                          |
| 112                     | Near River Intake     | 33.1489   | -81.7557   | NE            | 0.6              | NE            | 1.0              | D                          |
| 3                       | River Bank            | 33.148329 | -81.753059 | NE            | 0.7              | ENE           | 1.1              | D                          |
| 4                       | River Bank            | 33.146024 | -81.748912 | ENE           | 0.8              | ENE           | 1.3              | D                          |
| 5                       | River Bank            | 33.142488 | -81.745196 | E             | 1.0              | E             | 1.5              | D                          |
| 6                       | Plant Wilson          | 33.138484 | -81.744929 | ESE           | 1.1              | E             | 1.5              | D                          |
| 7                       | Simulator Building    | 33.125125 | -81.741427 | SE            | 1.7              | ESE           | 2.0              | D                          |
| 8                       | River Road            | 33.126262 | -81.754303 | SSE           | 1.1              | SE            | 1.4              | D                          |
| 9                       | River Road            | 33.125974 | -81.762186 | S             | 1.1              | SSE           | 1.1              | D                          |
| 10                      | River Road            | 33.126584 | -81.770513 | SSW           | 1.1              | S             | 1.0              | D                          |
| 11                      | River Road            | 33.12939  | -81.777146 | SW            | 1.2              | SSW           | 0.9              | D                          |
| 12                      | River Road            | 33.13605  | -81.781074 | WSW           | 1.2              | WSW           | 0.7              | D                          |
| 13                      | River Road            | 33.142923 | -81.785256 | W             | 1.3              | W             | 0.9              | D                          |
| 113                     | River Road            | 33.1327   | -81.7804   | WSW           | 1.1              | SW            | 0.8              | D                          |
| 114                     | River Road            | 33.1475   | -81.7887   | WNW           | 1.5              | WNW           | 1.2              | D                          |
| 14                      | River Road            | 33.154405 | -81.790894 | WNW           | 1.8              | WNW           | 1.8              | D                          |
| 15                      | Hancock Landing Road  | 33.158597 | -81.780185 | NW            | 1.5              | NNW           | 1.5              | D                          |
| 115                     | Handcock Landing Road | 33.1618   | -81.7711   | NNW           | 1.5              | N             | 1.4              | D                          |

Table 4-4. Radiological Environmental Monitoring Locations

| Location Number | Descriptive Location                    | Latitude  | Longitude  | Units 1 and 2 |                  | Units 3 and 4 |                  | Sample Type <sup>(1)</sup> |
|-----------------|---|-----------|------------|---------------|------------------|---------------|------------------|----------------------------|
|                 |   |           |            | Direction     | Distance (miles) | Direction     | Distance (miles) |                            |
| 16              | Hancock Landing Road                    | 33.161434 | -81.768968 | NNW           | 1.4              | NNW           | 1.4              | D                          |
| OSLD Outer Ring |   |           |            |               |                  |               |                  |                            |
| 17              | Savannah River Site, River Road         | 33.22067  | -81.764828 | N             | 5.4              | N             | 5.5              | D                          |
| 18              | Savannah River Site, D Area             | 33.210372 | -81.731879 | NNE           | 5.0              | N             | 5.5              | D                          |
| 19              | Savannah River Site, Road A.13          | 33.19516  | -81.714049 | NE            | 4.6              | NE            | 5.0              | D                          |
| 20              | Savannah River Site, Road A.13.1        | 33.176893 | -81.691737 | ENE           | 4.8              | ENE           | 4.8              | D                          |
| 21              | Savannah River Site, Road A.17          | 33.133389 | -81.661389 | E             | 5.3              | E             | 5.1              | D                          |
| 22              | River Bank Downstream of Buxton Landing | 33.110752 | -81.679244 | ESE           | 5.2              | ESE           | 5.6              | D                          |
| 23              | River Road                              | 33.096649 | -81.704853 | SE            | 4.6              | SE            | 4.8              | D                          |
| 24              | Chance Road                             | 33.07504  | -81.727965 | SSE           | 4.9              | SSE           | 5.2              | D                          |
| 25              | Chance Road near Highway 23             | 33.067735 | -81.756422 | S             | 5.2              | S             | 5.1              | D                          |
| 26              | Highway 23 and Ebenezer Church Rd.      | 33.078314 | -81.789467 | SSW           | 4.6              | SSW           | 4.5              | D                          |
| 27              | Highway 23, opposite Boll Weevil Road   | 33.086999 | -81.81091  | SW            | 4.7              | SSW           | 4.1              | D                          |
| 117             | Highway 23, near Jack Delaigle Road     | 33.0978   | -81.8301   | SW            | 4.9              | SW            | 4.6              | D                          |
| 28              | Thomas Road                             | 33.115188 | -81.843188 | WSW           | 5.0              | WSW           | 4.6              | D                          |

Table 4-4. Radiological Environmental Monitoring Locations

| Location Number              | Descriptive Location              | Latitude  | Longitude  | Units 1 and 2 |                  | Units 3 and 4 |                  | Sample Type <sup>(1)</sup> |
|------------------------------|-----------------------------------|-----------|------------|---------------|------------------|---------------|------------------|----------------------------|
|                              |                                   |           |            | Direction     | Distance (miles) | Direction     | Distance (miles) |                            |
| 29                           | Claxton-Lively Road               | 33.140699 | -81.847843 | W             | 5.1              | W             | 4.5              | D                          |
| 30                           | Nathaniel Howard Road             | 33.157737 | -81.846134 | WNW           | 5.0              | WNW           | 4.6              | D                          |
| 31                           | River Road at Allen's Chapel Fork | 33.191992 | -81.82585  | NW            | 5.0              | NW            | 4.8              | D                          |
|                              |                                   |           |            |               |                  |               |                  |                            |
| 116                          | Shell Bluff Landing Road          | 33.2213   | -81.8206   | NNW           | 6.4              | NNW           | 6.3              | D                          |
| OSLD Special Interest        |                                   |           |            |               |                  |               |                  |                            |
| 35                           | Girard                            | 33.053359 | -81.722694 | SSE           | 6.6              | SSE           | 6.6              | D                          |
| 43                           | Employees Recreation Area         | 33.116095 | -81.786647 | SW            | 2.2              | SSW           | 2.0              | D                          |
| Radioiodine and Particulates |                                   |           |            |               |                  |               |                  |                            |
| 3                            | Discharge Area                    | 33.148884 | -81.756429 | NE            | 0.6              | NE            | 0.9              | A                          |
| 118                          | Near Vogtle 1&2 Cooling Tower     | 33.1441   | -81.7524   | ENE           | 0.6              | ENE           | 1.0              | A                          |
| 119                          | Near Plant Wilson                 | 33.1418   | -81.7504   | E             | 0.7              | E             | 1.2              | A                          |
| 7                            | Simulator Building                | 33.125125 | -81.741427 | SE            | 1.7              | ESE           | 2.0              | A                          |
| 12                           | River Road                        | 33.13605  | -81.781074 | WSW           | 1.2              | WSW           | 0.7              | A                          |
|                              |                                   |           |            |               |                  |               |                  |                            |
| 35                           | Girard                            | 33.053359 | -81.722694 | SSE           | 6.6              | SSE           | 6.6              | A                          |
|                              |                                   |           |            |               |                  |               |                  |                            |
| Vegetation                   |                                   |           |            |               |                  |               |                  |                            |
| 7                            | Simulator Building                | 33.125125 | -81.741427 | SE            | 1.7              | ESE           | 2.0              | V                          |

Table 4-4. Radiological Environmental Monitoring Locations

| Location Number        | Descriptive Location                                    | Latitude  | Longitude  | Units 1 and 2 |                  | Units 3 and 4 |                  | Sample Type <sup>(1)</sup>        |
|------------------------|---|-----------|------------|---------------|------------------|---------------|------------------|-----------------------------------|
|                        |   |           |            | Direction     | Distance (miles) | Direction     | Distance (miles) |                                   |
| 15                     | Hancock Landing Road                                    | 33.158597 | -81.780185 | NW            | 1.5              | NW            | 1.5              | V                                 |
| 37                     | Substation; Waynesboro, GA                              | 33.08973  | -82.050789 | WSW           | 16.7             | WSW           | 16.7             | V                                 |
| 110                    | Vogtle 1 & 2 River Intake                               | 33.14865  | -81.754775 | NE            | 0.6              | ENE           | 1.0              | V                                 |
| 111                    | Wilson Transmission Line ROW                            | 33.1416   | -81.750488 | E             | 0.7              | E             | 1.1              | V                                 |
| Surface/Drinking Water |   |           |            |               |                  |               |                  |                                   |
| 80                     | Augusta Water Treatment Plant                           | 33.513381 | -82.007061 | NNW           | 29.0             | NNW           | 29.2             | W <sup>(2)</sup>                  |
| 88                     | Cherokee Hill Water Treatment Plant; Port Wentworth, GA | 32.256707 | -81.176718 | SSE           | 72.0             | SSE           | 70.0             | W <sup>(6)</sup>                  |
| 89                     | Purrysburg Water Treatment Plant; Purrysburg, SC        | 32.356629 | -81.119593 | SSE           | 76.0             | SSE           | 66.0             | W <sup>(7)</sup>                  |
| Fish / Sediment        |   |           |            |               |                  |               |                  |                                   |
| 81                     | Savannah River  | N/A       | N/A        | N             | 2.5              | NE            | 1.1              | F <sup>(3)</sup> S <sup>(4)</sup> |
| 83                     | Savannah River (RM 150.4)                               | 33.145799 | -81.748941 | ENE           | 0.8              | ENE           | 1.3              | S <sup>(4)</sup>                  |
| 85                     | Savannah River  | N/A       | N/A        | ESE           | 4.3              | ESE           | 4.3              | F <sup>(3)</sup>                  |
| River Water            |   |           |            |               |                  |               |                  |                                   |
| 82                     | Savannah River (RM 151.2)                               | 33.151993 | -81.756368 | NNE           | 0.8              | ENE           | 1.3              | R                                 |
| 83                     | Savannah River (RM 150.4)                               | 33.145799 | -81.748941 | ENE           | 0.8              | ENE           | 1.3              | R                                 |
| 84                     | Savannah River (RM 149.5)                               | 33.136268 | -81.734649 | ESE           | 1.6              | E             | 2.1              | R                                 |

Table 4-4. Radiological Environmental Monitoring Locations

| Location Number     | Descriptive Location | Latitude | Longitude | Units 1 and 2 |                  | Units 3 and 4 |                  | Sample Type <sup>(1)</sup> |
|---------------------|----------------------|----------|-----------|---------------|------------------|---------------|------------------|----------------------------|
|                     |                      |          |           | Direction     | Distance (miles) | Direction     | Distance (miles) |                            |
| Milk <sup>(8)</sup> |                      |          |           |               |                  |               |                  |                            |
|                     |                      |          |           |               |                  |               |                  |                            |
|                     |                      |          |           |               |                  |               |                  |                            |

Table 4-4 (cont.) Radiological Environmental Monitoring Locations

**TABLE NOTATIONS**

- (1) Sample Types:
- A - Airborne Radioactivity
  - D - Direct Radiation
  - F - Fish
  - M - Milk
  - R - River Water
  - S - River Shoreline Sediment
  - W - Drinking Water (at water treatment plant)
  - V - Vegetation
- (2) The intake for the Augusta Water Treatment Plant is located on the Augusta Canal. The entrance to this canal is at river mile (RM) 207 on the Savannah River. The canal effectively parallels the river. The intake to the pumping station is about 4 miles down the canal and only 0.1 mile from the river (across land).
- (3) About a 5-mile stretch of the river is generally needed to obtain adequate fish samples. Samples are normally gathered between RM 153 and 158 for upriver collections and between RMs 144 and 149.4 for downriver collections.
- (4) Sediment is collected at locations with existing or potential recreational value. High water shifting of the river bottom or other reasons could cause a suitable location for sediment collection to become unavailable or unsuitable. Thus, a stretch of river between RM 148.5 and 150.5 is designated for downriver sediment collections, while a stretch between RM 153 and 154 is designated for upriver collections. In practice, collections are normally made at RM 150.2 for downriver collections and at RM 153.3 for upriver collections.
- (5) Not Used
- (6) The intake for the Cherokee Hill Water Treatment Plant is located on Abercorn Creek, which is about one and a quarter creek miles from its mouth on the Savannah River at RM 29.
- (7) The intake for the Purrysburg Water Treatment Plant is located on the same canal as the Beaufort–Jasper Water Treatment Plant. The Purrysburg intake is nearer to the Savannah River at the beginning of the canal.
- (8) No milk farms located within 5-miles of the Site.

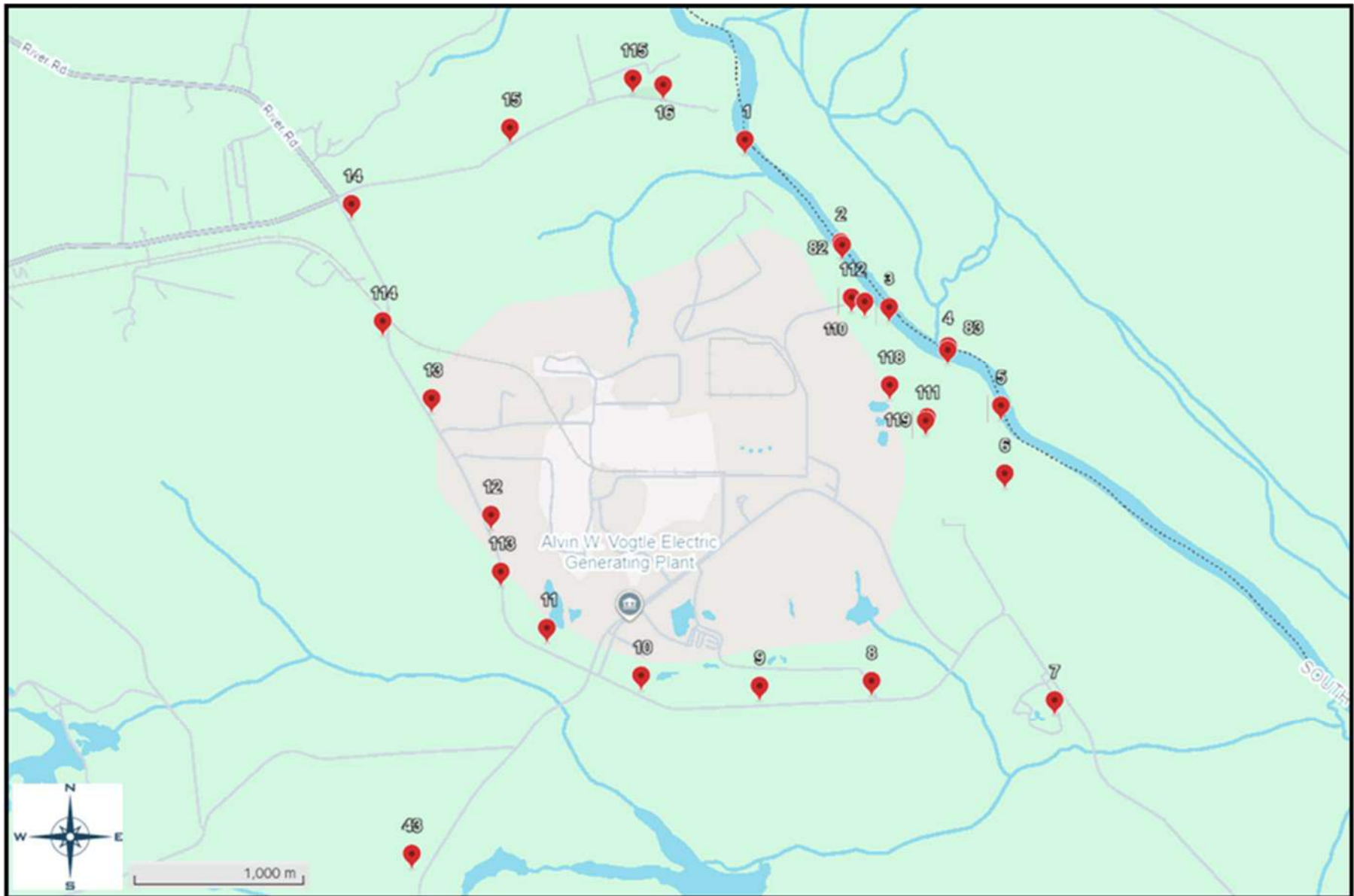

Figure 4-1. Sampling Location Map (Onsite)

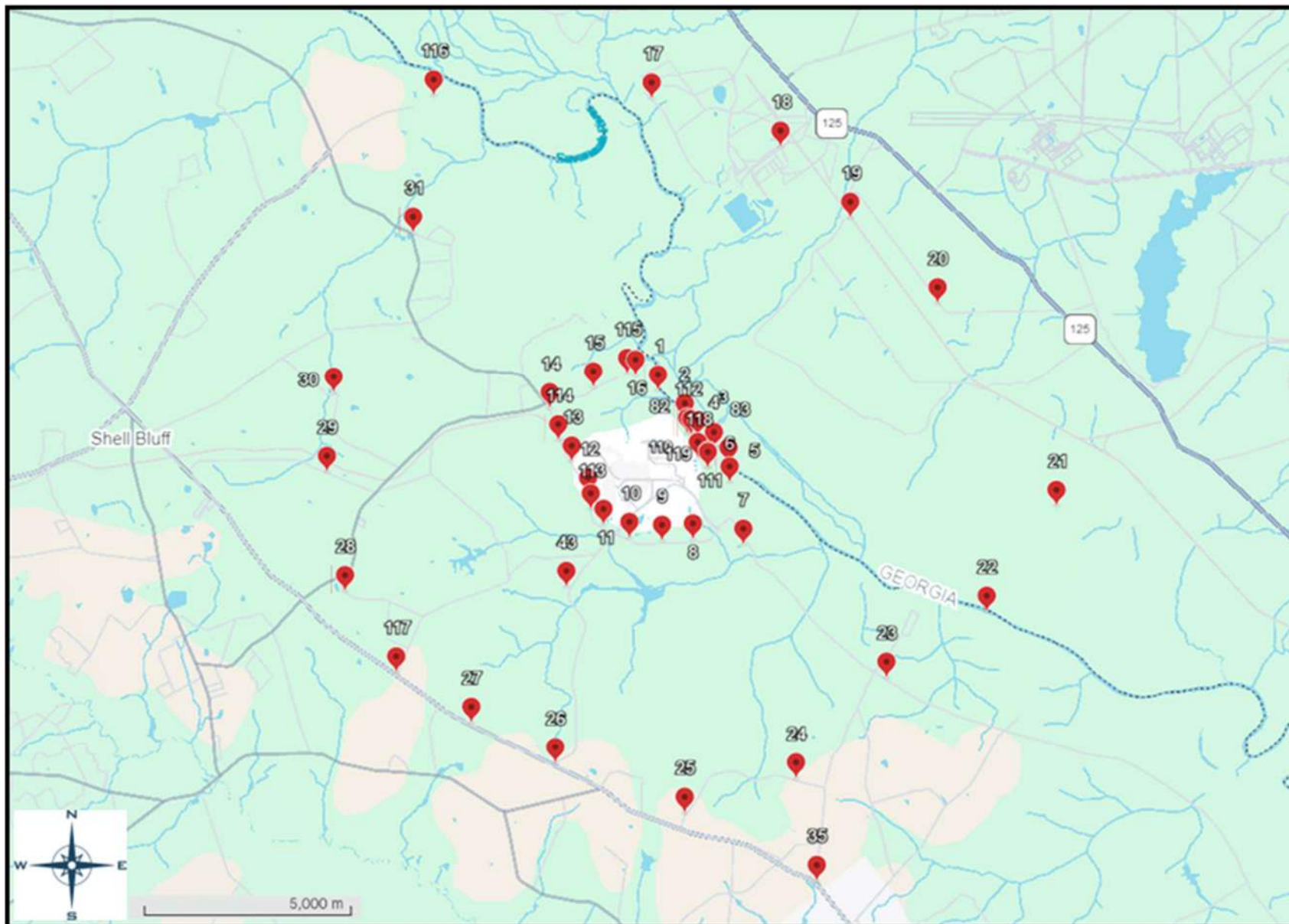

Figure 4-2. Sampling Location Map (Near Field/Site Boundary)

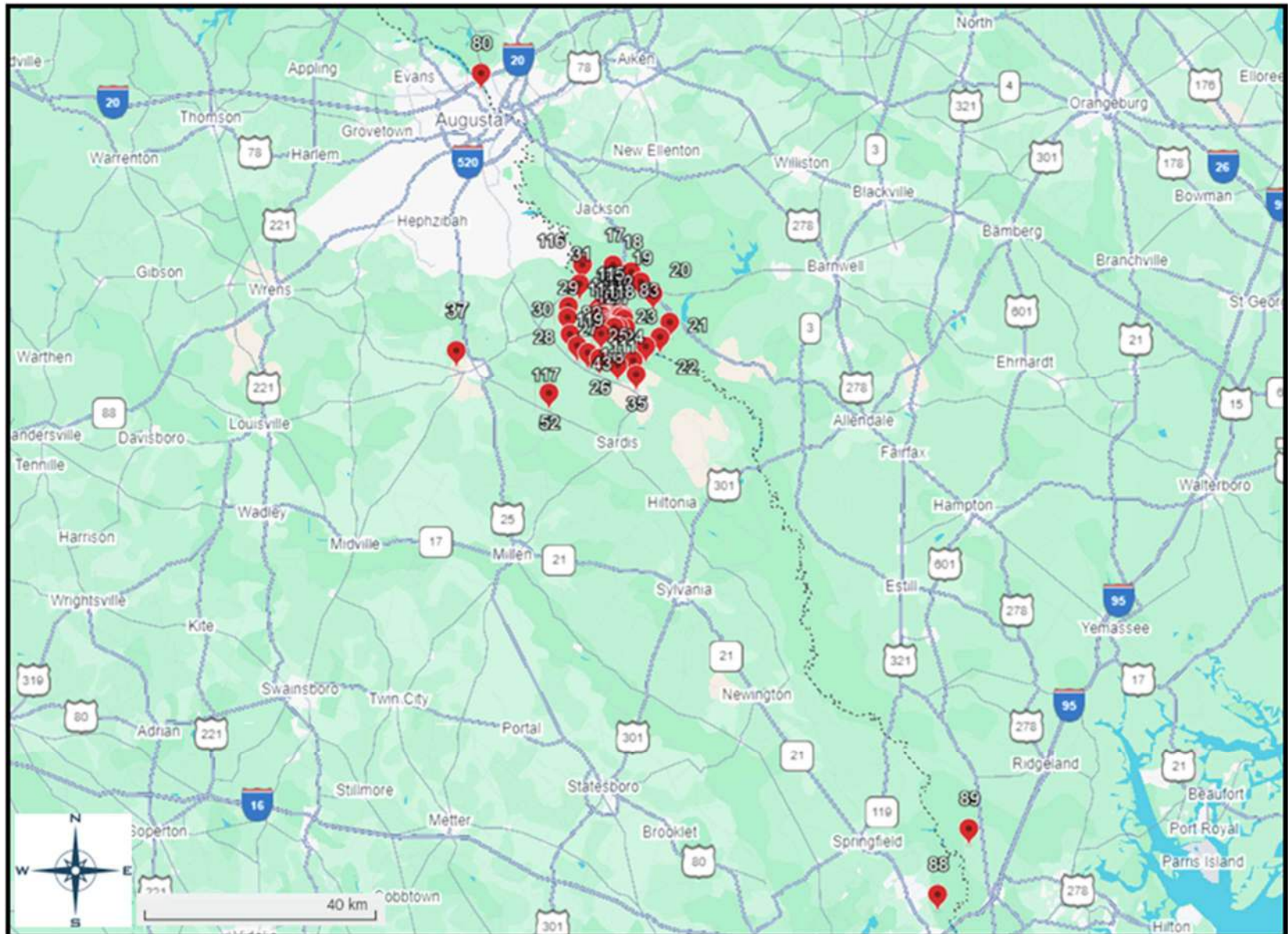

Figure 4-3. Sampling Location Map (Far Field)

---

CHAPTER 5  
TOTAL DOSE DETERMINATIONS

5.1 LIMIT OF OPERATION

In accordance with Technical Specification 5.5.4.j, the dose or dose commitment to any MEMBER OF THE PUBLIC over a calendar year, due to releases of radioactivity and to radiation from uranium fuel cycle sources, shall be limited to less than or equal to 25 mrem to the total body or any organ, except the thyroid, which shall be limited to less than or equal to 75 mrem.

5.1.1 Applicability

This limit applies at all times.

5.1.2 Actions

With the calculated doses from the release of radioactive materials in liquid or gaseous effluents exceeding twice the limits of Section 2.1.3, 3.1.3, or 3.1.4, calculations shall be made according to Section 5.2 methods to determine whether the limits of Section 5.1 have been exceeded. If these limits have been exceeded, prepare and submit a special report to the Nuclear Regulatory Commission within 30 days, which defines the corrective actions to be taken to reduce subsequent releases to prevent recurrence of exceeding the limits of Section 5.1 and includes the schedule for achieving conformance with the limits of Section 5.1. This special report, as defined in 10 CFR 20.2203, shall also include an analysis which estimates the radiation exposure (dose) to a MEMBER OF THE PUBLIC from uranium fuel cycle sources (including all effluent pathways and direct radiation) for the calendar year that includes the release(s) covered by this report. This special report shall also describe the levels of radiation and concentrations of radioactive material involved, and the cause of the exposure levels or concentrations. If the estimated dose(s) exceeds the limits of Section 5.1, and if the release condition resulting in violation of the provisions of 40 CFR 190 has not already been corrected, the special report shall include a request for variance in accordance with the provisions of 40 CFR 190 and including the specified information of 40 CFR 190.11(b). Submittal of the report is considered a timely request, and a variance is granted until staff action on the request is complete.

This control does not affect shutdown requirements or MODE changes.

5.1.3 Surveillance Requirements

Cumulative dose contributions from liquid and gaseous effluents and from direct radiation shall be determined in accordance with Section 5.2. This requirement is applicable only under the conditions set forth above in Section 5.1.2.

5.1.4 Basis

This control is provided to meet the dose limitations and reporting requirements of 40 CFR 190. The control requires the preparation and submittal of a special report whenever the calculated doses from plant radioactive effluents exceed the limits of Section 5.1. For sites containing up to 4 reactors, it is highly unlikely that the resultant dose to a MEMBER OF THE PUBLIC will exceed the dose limits of 40 CFR 190 if the individual reactors remain within twice the dose design

---

objectives of Appendix I and if direct radiation doses from the units, such as direct exposure from outside storage tanks, are kept small. The special report will describe a course of action which should result in the limitation of dose to a MEMBER OF THE PUBLIC for a calendar year to within the 40 CFR 190 limits. For the purposes of the special report, it may be assumed that the dose commitment to the MEMBER OF THE PUBLIC from other uranium fuel cycle sources is negligible with the exception that dose contributions from other uranium fuel cycle facilities at the same site or within a radius of 5 miles must be considered. If the dose to any MEMBER OF THE PUBLIC is estimated to exceed the requirements of 40 CFR 190, the special report with a request for variance (provided the release conditions resulting in violation of 40 CFR 190 have not already been corrected), in accordance with the provisions of 40 CFR 190.11 and 10 CFR 20.2203(a)(4), is considered to be a timely request and fulfills the requirements of 40 CFR 190 until NRC staff action is completed. The variance only relates to the limits of 40 CFR 190, and does not apply in any way to the requirements for dose limitation as addressed in other sections of this ODCM. An individual is not considered a MEMBER OF THE PUBLIC during any period in which he/she is engaged in carrying out any operation which is part of the nuclear fuel cycle.

## 5.2 DEMONSTRATION OF COMPLIANCE

There are no other uranium fuel cycle facilities within 5 miles of the plant site. Therefore, for the purpose of demonstrating compliance with the limits of Section 5.1, the total dose to a MEMBER OF THE PUBLIC in the vicinity of the plant site due to uranium fuel cycle sources shall be determined as follows:

$$D_{Tk} = D_L + D_G + D_D + D_N \quad (5.1)$$

where:

- $D_{Tk}$  = the total dose or dose commitment to the total body or organ k, in mrem.
- $D_L$  = the dose to the same organ due to radioactivity discharged from the plant site in liquid effluents, calculated in accordance with Section 2.4.1, in mrem.
- $D_G$  = the dose to the same organ due to non-noble-gas radionuclides discharged from the plant site in gaseous effluents, calculated for the controlling receptor in accordance with Section 3.4.3, in mrem.
- $D_D$  = the direct radiation dose to the whole body of an individual at the controlling receptor location, due to radioactive materials retained within the plant site, in mrem. Values of direct radiation dose may be determined by measurement, calculation, or a combination of the two.
- $D_N$  = the external whole body dose to an individual at the controlling receptor location, due to gamma ray emissions from noble gas radionuclides discharged from the plant site in gaseous effluents, in mrem.  $D_N$  is calculated as follows (equation adapted from Reference 1, page 22, by recasting in cumulative dose form):

$$D_N = 3.17 \times 10^{-8} \sum_v \left\{ \left( \overline{X/Q} \right)_{vp} \sum_i \left[ K_i \cdot \tilde{Q}_{iv} \right] \right\} \quad (5.2)$$

where:

$3.17 \times 10^{-8}$  = a units conversion factor:  $1 \text{ y}/(3.15 \times 10^7 \text{ s})$ .

$\tilde{Q}_{iv}$  = the cumulative release of noble gas radionuclide i from release pathway v ( $\mu\text{Ci}$ ), during the period of interest.

$K_i$  = the total-body dose factor due to gamma emissions from noble gas radionuclide i ( $\text{mrem/y}/(\mu\text{Ci}/\text{m}^3)$ ), from Table 3-5.

$\left( \overline{X/Q} \right)_{vp}$  = annual average relative dispersion factor for release pathway v, at the location of the controlling receptor, from Table 3-7 [ $\text{s}/\text{m}^3$ ].

---

As defined above,  $D_L$  and  $D_G$  are for different age groups, while  $D_D$  and  $D_N$  are not age group specific. When a more precise determination of  $D_{TK}$  is desired, values of  $D_L$  and  $D_G$  may be calculated for all four age groups, and those values used in equation (5.1) to determine age group specific values of  $D_{TK}$ ; the largest value of  $D_{TK}$  for any age group may then be compared to the limits of Section 5.1.

CHAPTER 6  
POTENTIAL DOSES TO MEMBERS OF THE PUBLIC DUE TO  
 THEIR ACTIVITIES INSIDE THE SITE BOUNDARY

### 6.1 REQUIREMENT FOR CALCULATION

To support the reporting requirements of Section 7.2.2.3, an assessment of the radiation doses from radioactive liquid and gaseous effluents to MEMBERS OF THE PUBLIC due to their activities inside the SITE BOUNDARY shall be performed as specified in Section 6.2, at least once per calendar year.

### 6.2 CALCULATIONAL METHOD

For the purpose of performing the calculations required in Section 6.1, the dose to a member of the public inside the SITE BOUNDARY shall be determined at the locations, and for the receptor age groups, defined in Table 6-1. The dose to such a receptor at any one of the defined locations shall be determined as follows:

$$D_{ik} = [D_A + D_S + D_P] \cdot F_o \quad (6.1)$$

where:

- $D_{ik}$  = the total dose to the total body or organ k, in mrem.
- $D_A$  = the dose to the same organ due to inhalation of non-noble-gas radionuclides discharged from the plant site in gaseous effluents, calculated in accordance with Section 3.4.3, in mrem. The  $\overline{(X/Q)}$  value to be used is given for each receptor location in Table 6-1; depleted  $\overline{(X/Q)}$  values may be used in calculations for non-noble-gas radionuclides.
- $D_S$  = the dose to the same organ due to ground plane deposition of non-noble-gas radionuclides discharged from the plant site in gaseous effluents, calculated in accordance with Section 3.4.3, in mrem. The  $\overline{(D/Q)}$  value to be used is given for each receptor location in Table 6-1.
- $D_P$  = the external whole body dose due to gamma ray emissions from noble gas radionuclides discharged from the plant site in gaseous effluents, calculated using equation (5.2), in mrem. The  $\overline{(X/Q)}$  values that are to be used are given for each receptor location in Table 6-1.
- $F_o$  = the occupancy factor for the given location, which is the fraction of the year that one individual MEMBER OF THE PUBLIC is assumed to be present at the receptor location [unitless]. Values of  $F_o$  for each receptor location are included in Table 6-1.

---

 Table 6-1. Attributes of Member of the Public Receptor Locations Inside the Site Boundary
 

---

**Location: Visitors Center, SE at 447 meters**Age Group: ChildOccupancy Factor:  $4.57 \times 10^{-4}$  (based on 4 hours per year)Dispersion and Deposition Parameters:

| Parameter  | Ground-Level | Mixed-Mode |
|--|--------------|------------|
| Undepleted $(\overline{X/Q})$ , s/m <sup>3</sup> | 5.93 E-6     | 7.12 E-7   |
| Depleted $(\overline{X/Q})$ , s/m <sup>3</sup>   | 5.58 E-6     | 6.74 E-7   |
| $(\overline{D/Q})$ , m <sup>-2</sup>             | 2.28 E-8     | 5.77 E-9   |

---

## CHAPTER 7 REPORTS

### 7.1 ANNUAL RADIOLOGICAL ENVIRONMENTAL OPERATING REPORT

#### 7.1.1 Requirement for Report

In accordance with Technical Specification 5.6.2, the Annual Radiological Environmental Operating Report covering the REMP activities during the previous calendar year shall be submitted before May 15 of each year. (A single report fulfills the requirements for both units.) The material provided shall be consistent with the objectives outlined in section 4.1 and section 7.1.2 of the ODCM, and in Sections IV.B.2, IV.B.3, and IV.C of Appendix I to 10 CFR Part 50.

#### 7.1.2 Report Contents

The materials specified in the following subsections shall be included in each Annual Radiological Environmental Operating Report:

##### 7.1.2.1 Data

The report shall include summarized and tabulated results of all REMP samples required by Table 4-1 taken during the report period, in a format similar to that contained in Table 3 of the Radiological Assessment Branch Technical Position (Reference 19); the results for any additional samples shall also be reported. In the event that some results are not available for inclusion with the report, the report shall be submitted noting and explaining the reasons for the missing results; the missing data shall be submitted as soon as possible in a supplementary report. The results for naturally-occurring radionuclides not included in plant effluents need not be reported.

##### 7.1.2.2 Evaluations

Interpretations and analyses of trends of the results shall be included in the report, including the following: (as appropriate) comparisons with preoperational studies, operational controls, and previous environmental reports; and an assessment of any observed impacts of the plant operation on the environment. If the measured level of radioactivity in an environmental sampling medium exceeding the reporting levels of Table 4-2 is not the result of plant effluents, the condition shall be described as required by Section 4.1.1.2.2.

##### 7.1.2.3 Programmatic Information

Also to be included in each report are the following: a summary description of the REMP; a map(s) of all sampling locations keyed to a table giving distances and directions from a point midway between the centers of the two reactors; the results of land use censuses required by Section 4.1.2; and the results of licensee participation in the Interlaboratory Comparison Program required by Section 4.1.3.

##### 7.1.2.4 Descriptions of Program Deviations

Discussions of deviations from the established program must be included in each report, as follows:

---

7.1.2.4.1 If the REMP is not conducted as required in Table 4-1, a description of the reasons for not conducting the program as required, and the plans for preventing a recurrence, must be included in the report.

7.1.2.4.2 If the MDCs required by Table 4-3 are not achieved, the contributing factors must be identified and described in the report.

7.1.2.4.3 If Interlaboratory Comparison Program analyses are not performed as required by Section 4.1.3, the corrective actions taken to prevent a recurrence must be included in the report.

---

## 7.2 RADIOACTIVE EFFLUENT RELEASE REPORT

### 7.2.1 Requirement for Report

In accordance with Technical Specification 5.6.3, the Radioactive Effluent Release Report covering the operation of the units during the previous calendar year of operation shall be submitted in accordance with 10 CFR Part 50.36a. (A single submittal may be made for Units 1 and 2. However, the submittal shall specify the releases of radioactive material in liquid and gaseous effluents from each unit and solid radioactive waste from the site.) The report shall include a summary of the quantities of radioactive liquid and gaseous effluents and solid waste released from the units. The material provided shall be consistent with the objectives outlined throughout this ODCM and the Process Control Program (PCP) and in conformance with 10 CFR Part 50.36a and Section IV.B.1 of Appendix I to 10 CFR Part 50.

### 7.2.2 Report Contents

The materials specified in the following subsections shall be included in each Radioactive Effluent Release Report:

#### 7.2.2.1 Quantities of Radioactive Materials Released

The report shall include a summary of the quantities of radioactive liquid and gaseous effluents and solid waste released from the units as outlined in NRC Regulatory Guide 1.21, "Measuring, Evaluating, and Reporting Radioactivity in Solid Wastes and Releases of Radioactive Materials in Liquid and Gaseous Effluents from Light-Water-Cooled Nuclear Power Plants," Revision 1, June 1974, with liquid and gaseous effluent data summarized on a quarterly basis and solid radioactive waste data summarized on a semiannual basis following the format of Appendix B thereof. Unplanned releases of radioactive materials in gaseous and liquid effluents from the site to UNRESTRICTED AREAS shall be included in the report, tabulated either by quarter or by event. For gamma emitters released in liquid and gaseous effluents, in addition to the principal gamma emitters for which MDCs are specifically established in Table 2-3 and Table 3-3, other peaks which are measurable and identifiable also shall be identified and reported.

#### 7.2.2.2 Meteorological Data

The report shall include an annual summary of hourly meteorological data collected over the previous year. This annual summary may be either in the form of an hour-by-hour listing of wind speed, wind direction, and atmospheric stability, and precipitation (if measured) on digital media; or in the form of joint frequency distributions of wind speed, wind direction, and atmospheric stability. In lieu of submission with the Radioactive Effluent Release Report, the licensee has the option of retaining this summary of required meteorological data on site in a file that shall be provided to the NRC upon request.

#### 7.2.2.3 Dose Assessments

The report shall include an assessment of the radiation doses due to the radioactive liquid and gaseous effluents released from each unit during the previous calendar year. Historical annual average meteorology or the meteorological conditions concurrent with the time of release of radioactive materials in gaseous effluents (as determined by sampling frequency and measurement) shall be used for determining the gaseous pathway doses. This assessment of

radiation doses shall be performed in accordance with Sections 2.1.3, 2.4, 3.1.3, 3.1.4, 3.4.2, 3.4.3, 5.1, and 5.2.

If a determination is required by Section 5.1.2, the report shall also include an assessment of radiation doses to the likely most exposed MEMBER OF THE PUBLIC from reactor releases and other nearby uranium fuel cycle sources (including doses from primary effluent pathways and direct radiation) for the previous calendar year to show conformance with 40 CFR 190, Environmental Radiation Protection Standards for Nuclear Power Operation; this dose assessment must be performed in accordance with Chapter 5. The report shall also include an assessment of the radiation doses from radioactive liquid and gaseous effluents to MEMBERS OF THE PUBLIC due to their activities inside the SITE BOUNDARY during the report period; this assessment must be performed in accordance with Chapter 6. All assumptions used in making these assessments (i.e., specific activity, exposure time, and location) shall be included in the report.

#### 7.2.2.4 Solid Radwaste Data

For each type of solid waste shipped offsite during the report period, the following information shall be included:

- a. Waste volume,
- b. Total curie quantity (specify whether determined by measurement or estimate),
- c. Principal radionuclides (specify whether determined by measurement or estimate),
- d. Type of waste (e.g., spent resin, compacted dry waste, evaporator bottoms),
- e. Type of container (e.g., LSA, Type A, Type B, Large Quantity),
- f. Solidification agent (e.g., cement, urea formaldehyde)  
and
- g. Class of solid wastes (as defined by 10 CFR Part 61.)

#### 7.2.2.5 Licensee Initiated Document Changes

Licensee initiated changes shall be submitted to the Nuclear Regulatory Commission as a part of or concurrent with the Radioactive Effluent Release Report for the period in which any changes were made. Such changes to the ODCM shall be submitted pursuant to Technical Specification 5.5.1. This requirement includes:

7.2.2.5.1 Any changes to the sampling locations in the radiological environmental monitoring program, including any changes made pursuant to Section 4.1.1.2.3. Documentation of changes made pursuant to Section 4.1.1.2.3 shall include supporting information identifying the cause of the unavailability of samples.

7.2.2.5.2 Any changes to dose calculation locations or pathways, including any changes made pursuant to Section 4.1.2.2.2.

#### 7.2.2.6 Descriptions of Program Deviations

Discussions of deviations from the established program shall be included in each report, as follows:

7.2.2.6.1 The report shall include deviations from the liquid and gaseous effluent monitoring instrumentation FUNCTIONALITY requirements included in Sections 2.1.1 and 3.1.1,

respectively. The report shall include an explanation as to why the NON-FUNCTIONALITY of the liquid or gaseous effluent monitoring instrumentation was not corrected within the specified time requirement.

7.2.2.6.2 The report shall include a description of the events leading to liquid holdup tanks or gas storage tanks exceeding the limits of Technical Specification 5.5.12.

#### 7.2.2.7 Major Changes to Radioactive Waste Treatment Systems

As required by Sections 2.1.5 and 3.1.6, licensee initiated MAJOR CHANGES TO RADIOACTIVE WASTE TREATMENT SYSTEMS (liquid and gaseous) shall be reported to the Nuclear Regulatory Commission in the Radioactive Effluent Release Report covering the period in which the change was reviewed and accepted for implementation.<sup>1</sup> The discussion of each change shall contain:

- a. A summary of the evaluation that led to the determination that the change could be made in accordance with 10 CFR 50.59;
- b. Sufficient detailed information to totally support the reason for the change without benefit of additional supplemental information;
- c. A detailed description of the equipment, components, and processes involved and the interfaces with other plant systems;
- d. An evaluation of the change which shows the predicted releases of radioactive materials in liquid and gaseous effluents that differ from those previously predicted in the license applications and amendments thereto;
- e. An evaluation of the change which shows the expected maximum exposures to individuals in the UNRESTRICTED AREA and to the general population that differ from those previously estimated in the license applications and amendments thereto;
- f. A comparison of the predicted releases of radioactive materials, in liquid and gaseous effluents, to the actual releases for the period prior to when the changes are to be made;
- g. An estimate of the exposure to plant operating personnel as a result of the change; and
- h. Documentation of the fact that the change was reviewed and found acceptable by the PRB.

---

<sup>1</sup> In lieu of inclusion in the Radioactive Effluents Release Report, this same information may be submitted as part of the annual FSAR update.

---

### 7.3 MONTHLY OPERATING REPORT

This ODCM establishes no requirements pertaining to the Monthly Operating Report.

### 7.4 SPECIAL REPORTS

Special reports shall be submitted to the Nuclear Regulatory Commission as required by Sections 2.1.3.2, 2.1.4.2, 3.1.3.2, 3.1.4.2, 3.1.5.2, 4.1.1.2.2, and 5.1.2.

CHAPTER 8  
METEOROLOGICAL MODELS

The models presented in this chapter are those which were used to compute the specific values of meteorology-related parameters that are referenced throughout this ODCM. These models should also be used whenever it is necessary to calculate values of these parameters for new locations of interest.

Note: Although Plant Vogtle has no pure elevated releases, the sections on elevated-mode calculations (8.1.2 and 8.2.2) are included for convenience in calculating mixed-mode values, and to preserve section number compatibility with the ODCMs of the other Southern Company nuclear power plants.

## 8.1 ATMOSPHERIC DISPERSION

Atmospheric dispersion may be calculated using the appropriate form of the sector-averaged Gaussian model. Gaseous release elevations may be considered to be either at ground-level, elevated, or mixed-mode. Facility release elevations for each gaseous release point are as indicated in Table 3-4.

### 8.1.1 Ground-Level Releases

Relative concentration calculations for ground-level releases, or for the ground-level portion of mixed-mode releases, shall be made as follows:

$$(X/Q)_G = \frac{2.032 \delta K_r}{N r} \sum_{jk} \left[ \frac{n_{jk}}{u_j \sum_{zk}} \right] \quad (8.1)$$

where:

$(X/Q)_G$  = the ground-level sector-averaged relative concentration for a given wind direction (sector) and distance ( $s/m^3$ ).

$2.032 = (2/\pi)^{1/2}$  divided by the width in radians of a  $22.5^\circ$  sector, which is 0.3927 radians.

$\delta$  = the plume depletion factor for all radionuclides other than noble gases at a distance  $r$  shown in Figure 8-3. For noble gases, the depletion factor is unity. If an undepleted relative concentration is desired, the depletion factor is unity. Only depletion by deposition is considered since depletion by radioactive decay would be of little significance at the distances considered.

$K_r$  = the terrain recirculation factor corresponding to a distance  $r$ , taken from Appendix A of Reference 15.

$n_{jk}$  = the number of hours that wind of wind speed class  $j$  is directed into the given sector during the time atmospheric stability category  $k$  existed.

$N$  = the total hours of valid meteorological data recorded throughout the period of interest for all sectors, wind speed classes, and stability categories.

- $u_j =$  the wind speed (mid-point of wind speed class  $j$ ) at ground level (m/s).
- $r =$  the distance from release point to location of interest (m).
- $\Sigma_{zk} =$  the vertical standard deviation of the plume concentration distribution considering the initial dispersion within the building wake, calculated as follows:

$$\Sigma_{zk} = \text{the lesser of } \left\{ \begin{array}{l} \left( \sigma_{zk}^2 + \frac{b^2}{2\pi} \right)^{1/2} \\ \text{OR} \\ \sqrt{3}(\sigma_{zk}) \end{array} \right. \quad (8.2)$$

- $\sigma_{zk} =$  the vertical standard deviation of the plume concentration distribution (m) for a given distance and stability category  $k$  as shown in Figure 8-1. The stability category is determined by the vertical temperature gradient  $\Delta T/\Delta z$  ( $^{\circ}\text{C}/100 \text{ m}$ ).
- $\pi =$  3.1416
- $b =$  the maximum height of adjacent plant structure (55 m).

8.1.2 Elevated Releases

Relative dispersion calculations for elevated releases, or for the elevated portion of mixed-mode releases, shall be made as follows:

$$(X/Q)_E = \frac{2.032K_r}{N r} \sum_{jk} \left[ \frac{\delta_k n_{jk} \exp\left(\frac{-h^2}{2\sigma_{zk}^2}\right)}{u_j \sigma_{zk}} \right] \quad (8.3)$$

where:

- $(X/Q)_E =$  the elevated release sector-averaged relative concentration for a given wind direction (sector) and distance ( $\text{s}/\text{m}^3$ ).
- $\delta_k =$  the plume depletion factor for all radionuclides other than noble gases at a distance  $r$  for elevated releases, as shown in Figure 8-4, Figure 8-5, and Figure 8-6. For an elevated release, this factor is stability dependent. For noble gases, the depletion factor is unity. If an undepleted relative concentration is desired, the depletion factor is unity. Only depletion by deposition is considered since depletion by radioactive decay would be of little significance at the distances considered.
- $n_{jk} =$  the number of hours that wind of wind speed class  $j$  is directed into the given sector during the time atmospheric stability category  $k$  existed.

$u_j$  = the wind speed (mid-point of wind speed class  $j$ ) at the effective release height  $h$  (m/s).

$h$  = the effective height of the release (m), which is calculated as follows:

$$h = h_v + h_{pr} - h_t - c_v \quad (8.4)$$

$h_v$  = the height of the release point (m).

$h_t$  = the maximum terrain height between the release point and the point of interest (m), from Table 8-1.

$h_{pr}$  = the additional height due to plume rise (m) which is calculated as follows and limited by  $h_{pr(max)}$ :

$$h_{pr} = 1.44d \left( \frac{W_o}{u} \right)^{2/3} \cdot \left( \frac{x}{d} \right)^{1/3} \quad (8.5)$$

$$h_{pr(max)} = \text{the lesser of : } \begin{cases} 3 \left( \frac{W_o}{u} \right) \cdot d \\ OR \\ 1.5 \left( \frac{F_m}{u} \right)^{1/3} \cdot s^{-1/6} \end{cases} \quad (8.6)$$

$d$  = the inside diameter of the vent (m).

$c_v$  = the correction for low vent exit velocity (m), which is calculated as follows:

$$c_v = \begin{cases} 3 \left( 1.5 - \frac{W_o}{u} \right) \cdot d & \text{for } \frac{W_o}{u} < 1.5 \\ OR \\ 0 & \text{for } \frac{W_o}{u} \geq 1.5 \end{cases} \quad (8.7)$$

$F_m$  = the momentum flux parameter ( $m^4/s^2$ ), which is calculated as follows:

$$F_m = \left( W_o \cdot \frac{d}{2} \right)^2 \quad (8.8)$$

$S$  = the stability parameter:

$$\begin{aligned} &= 8.75 \times 10^{-4} \text{ s}^{-2} \text{ for } -0.5 < \Delta T \leq 1.5 \\ &= 1.75 \times 10^{-3} \text{ s}^{-2} \text{ for } 1.5 < \Delta T \leq 4.0 \end{aligned}$$

$$= 2.45 \times 10^{-3} \text{ s}^{-2} \text{ for } \Delta T > 4.0$$

All other symbols are as previously defined in Section 8.1.1.

### 8.1.3 Mixed-Mode Releases

Relative dispersion calculations for mixed-mode releases shall be made as follows:

$$(X/Q)_M = (1 - E) \cdot (X/Q)_E + E \cdot (X/Q)_G \quad (8.9)$$

where:

$(X/Q)_M$  = the mixed-mode release sector-averaged relative concentration for a given wind direction (sector) and distance ( $\text{s/m}^3$ ).

$E$  = the fraction of hours during which releases are considered as ground-level releases, calculated as follows:

$$E = \begin{cases} 1.0 & \text{for } \frac{W_o}{u_j} \leq 1.0 \\ 2.58 - 1.58 \cdot \left( \frac{W_o}{u_j} \right) & \text{for } 1.0 < \frac{W_o}{u_j} \leq 1.5 \\ 0.3 - 0.06 \cdot \left( \frac{W_o}{u_j} \right) & \text{for } 1.5 < \frac{W_o}{u_j} \leq 5.0 \\ 0 & \text{for } \frac{W_o}{u_j} > 5.0 \end{cases} \quad (8.10)$$

All other symbols are as previously defined.

## 8.2 RELATIVE DEPOSITION

Plume depletion may be calculated using the appropriate form of the sector-averaged Gaussian model. Gaseous release elevations may be considered to be either at ground-level, elevated, or mixed-mode. Facility release elevations for each gaseous release points are as indicated in Table 3-4.

### 8.2.1 Ground-Level Releases

Relative deposition calculations for ground-level releases, or for the ground-level portion of mixed-mode releases, shall be made as follows:

$$(D/Q)_G = \frac{2.55 D_g K_r}{N r} \sum_k n_k \quad (8.11)$$

where:

$(D/Q)_G$  = the ground-level sector-averaged relative deposition for a given wind direction (sector) and distance ( $m^{-2}$ ).

2.55 = the inverse of the number of radians in a  $22.5^\circ$  sector  $[= (2 \pi / 16)^{-1}]$ .

$D_g$  = the deposition rate at distance  $r$ , taken from Figure 8-7 for ground-level releases ( $m^{-1}$ ).

$n_k$  = the number of hours in which the wind is directed into the sector of interest, and during which stability category  $k$  exists.

All other symbols are as defined previously in Section 8.1.

### 8.2.2 Elevated Releases

Relative deposition calculations for elevated releases, or for the elevated portion of mixed-mode releases, shall be made as follows:

$$(D/Q)_E = \frac{2.55 K_r}{N r} \sum_k (n_k D_{ek}) \quad (8.12)$$

where:

$(D/Q)_E$  = the elevated-plume sector-averaged relative deposition for a given wind direction (sector) and distance ( $m^{-2}$ ).

$D_{ek}$  = the elevated plume deposition rate at distance  $r$ , taken from Figure 8-8, Figure 8-9, or Figure 8-10, as appropriate to the plume effective release height  $h$  defined in Section 8.1.2, for stability class  $k$  ( $m^{-1}$ ).

All other symbols are as defined previously.

---

### 8.2.3 Mixed-Mode Releases

Relative deposition calculations for mixed-mode releases shall be made as follows:

$$(D/Q)_M = (1 - E) \cdot (D/Q)_E + E \cdot (D/Q)_G \quad (8.13)$$

where:

$(D/Q)_M$  = the mixed-mode release sector-averaged relative deposition for a given wind direction (sector) and distance ( $m^{-2}$ ).

E = the fraction of hours during which releases are considered as ground-level releases, defined in Section 8.1.3.

All other symbols are as previously defined.

### 8.3 ELEVATED PLUME DOSE FACTORS

These factors are not required in effluent dose calculations for VEGP.

Table 8-1. Terrain Elevation Above Plant Site Grade

| Dist. (m) | N   | NNE  | NE   | ENE  | E    | ESE | SE   | SSE  | S    | SSW | SW   | WSW  | W    | WNW  | NW   | NNW |
|-----------|-----|------|------|------|------|-----|------|------|------|-----|------|------|------|------|------|-----|
| 500       | 0.0 | 0.0  | 0.0  | 0.0  | 0.0  | 0.0 | 0.0  | 0.0  | 0.0  | 4.7 | 8.7  | 5.7  | 1.4  | 5.8  | 5.7  | 3.5 |
| 1,000     | 0.0 | 0.0  | 0.0  | 0.0  | 0.0  | 0.0 | 0.0  | 0.0  | 0.0  | 4.7 | 16.7 | 13.4 | 3.3  | 10.4 | 11.8 | 6.8 |
| 1,500     | 0.0 | 0.0  | 0.0  | 0.0  | 0.0  | 0.0 | 0.0  | 0.0  | 0.0  | 4.7 | 21.7 | 18.6 | 7.3  | 12.2 | 14.3 | 7.3 |
| 2,000     | 0.0 | 0.0  | 0.0  | 0.0  | 0.0  | 0.0 | 0.0  | 0.0  | 0.0  | 4.7 | 21.7 | 18.6 | 7.3  | 12.2 | 14.3 | 7.3 |
| 2,500     | 0.0 | 0.0  | 0.0  | 0.0  | 0.0  | 0.0 | 0.0  | 0.0  | 0.0  | 4.7 | 21.7 | 18.6 | 7.3  | 12.2 | 14.3 | 7.3 |
| 3,000     | 0.0 | 0.0  | 0.0  | 0.0  | 0.0  | 0.0 | 0.0  | 0.0  | 0.0  | 4.7 | 23.7 | 18.6 | 7.3  | 12.2 | 14.3 | 7.3 |
| 3,500     | 0.0 | 0.0  | 0.0  | 0.0  | 0.0  | 0.0 | 0.0  | 0.0  | 0.0  | 4.7 | 24.4 | 18.6 | 7.3  | 12.2 | 16.9 | 7.3 |
| 4,000     | 0.0 | 0.0  | 0.0  | 0.0  | 0.0  | 0.0 | 4.5  | 0.0  | 0.0  | 4.7 | 24.4 | 18.6 | 7.3  | 12.2 | 16.9 | 7.3 |
| 5,000     | 0.0 | 0.0  | 0.0  | 0.0  | 0.0  | 0.0 | 11.1 | 0.0  | 0.0  | 4.7 | 24.7 | 18.6 | 7.3  | 12.2 | 16.9 | 7.3 |
| 6,000     | 0.0 | 0.0  | 0.0  | 0.0  | 0.0  | 0.0 | 11.1 | 0.0  | 0.0  | 4.7 | 26.8 | 18.6 | 7.3  | 12.2 | 16.9 | 7.3 |
| 7,000     | 0.0 | 0.0  | 0.0  | 7.8  | 0.0  | 0.0 | 11.1 | 0.0  | 3.6  | 4.7 | 26.8 | 18.6 | 7.3  | 12.2 | 16.9 | 7.3 |
| 8,000     | 0.0 | 0.0  | 21.1 | 13.9 | 0.0  | 0.0 | 11.8 | 0.0  | 14.6 | 4.7 | 26.8 | 18.6 | 7.3  | 12.2 | 16.9 | 7.3 |
| 9,000     | 0.0 | 0.0  | 24.4 | 14.6 | 0.0  | 0.0 | 12.7 | 7.1  | 14.6 | 5.1 | 26.8 | 18.6 | 7.3  | 12.2 | 16.9 | 7.3 |
| 10,000    | 0.0 | 10.2 | 24.4 | 20.2 | 0.0  | 0.0 | 17.1 | 17.0 | 14.6 | 6.8 | 26.8 | 18.6 | 7.3  | 12.2 | 16.9 | 7.3 |
| 12,000    | 0.0 | 15.9 | 26.8 | 20.2 | 0.0  | 0.0 | 17.1 | 19.5 | 14.6 | 6.8 | 34.1 | 28.9 | 13.4 | 12.2 | 16.9 | 7.3 |
| 14,000    | 0.0 | 15.9 | 26.8 | 20.2 | 0.0  | 0.0 | 17.1 | 19.5 | 14.6 | 6.8 | 34.1 | 28.9 | 13.4 | 16.5 | 19.7 | 7.3 |
| 16,000    | 0.0 | 15.9 | 26.8 | 21.7 | 13.2 | 0.0 | 17.1 | 19.5 | 14.6 | 6.8 | 34.1 | 28.9 | 13.4 | 16.5 | 25.7 | 7.3 |

Data in this table are obtained from Reference 11.

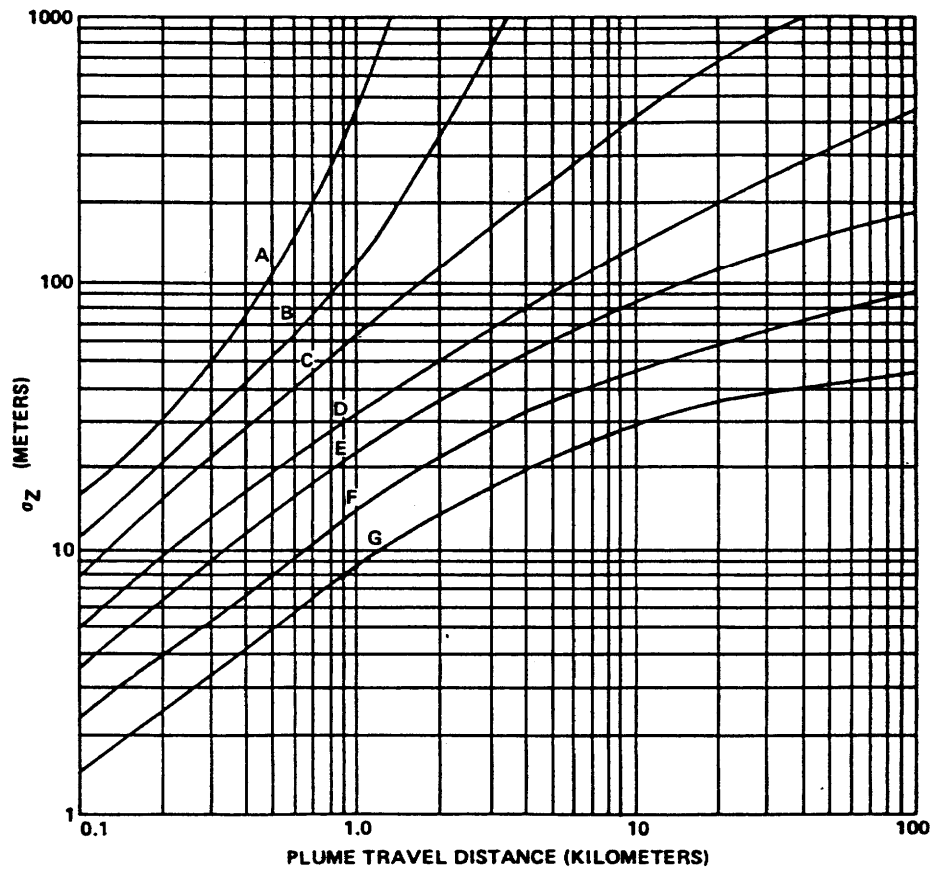

| Category | Range of Vertical Temperature Gradient (°C/100 m) | Range of Vertical Temperature Gradient (°F/100 ft) |
|----------|---|--|
| A        | $\Delta T/\Delta Z < -1.9$                        | $\Delta T/\Delta Z < -1.0$                         |
| B        | $-1.9 \leq \Delta T/\Delta Z < -1.7$              | $-1.0 \leq \Delta T/\Delta Z < -0.9$               |
| C        | $-1.7 \leq \Delta T/\Delta Z < -1.5$              | $-0.9 \leq \Delta T/\Delta Z < -0.8$               |
| D        | $-1.5 \leq \Delta T/\Delta Z < -0.5$              | $-0.8 \leq \Delta T/\Delta Z < -0.3$               |
| E        | $-0.5 \leq \Delta T/\Delta Z < 1.5$               | $-0.3 \leq \Delta T/\Delta Z < 0.8$                |
| F        | $1.5 \leq \Delta T/\Delta Z < 4.0$                | $0.8 \leq \Delta T/\Delta Z < 2.2$                 |
| G        | $4.0 \leq \Delta T/\Delta Z$                      | $2.2 \leq \Delta T/\Delta Z$                       |

This graph is reproduced from Reference 5 (Figure 1).

**Figure 8-1.** Vertical Standard Deviation of Material in a Plume ( $\sigma_z$ )

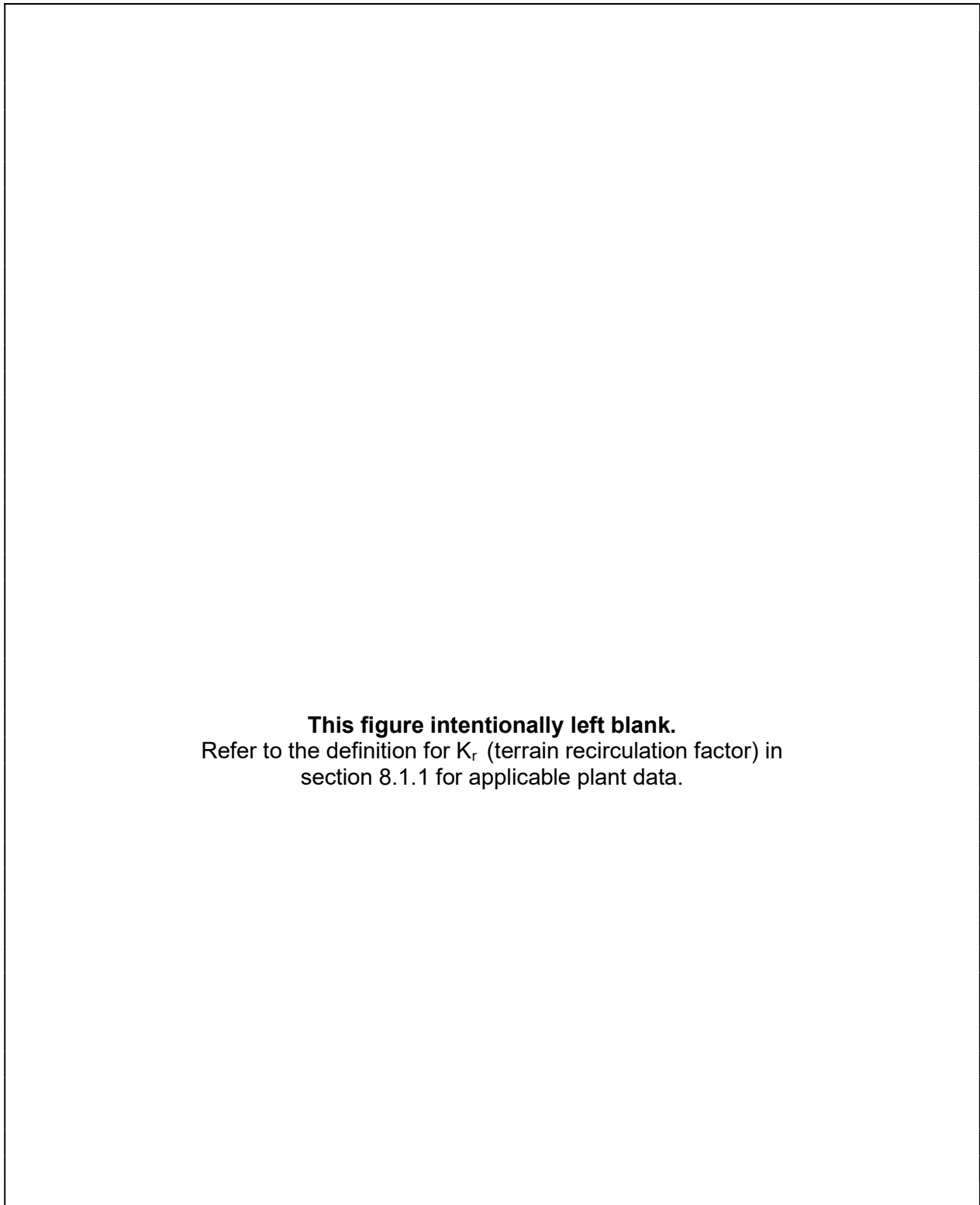

**Figure 8-2.** Terrain Recirculation Factor ( $K_r$ )

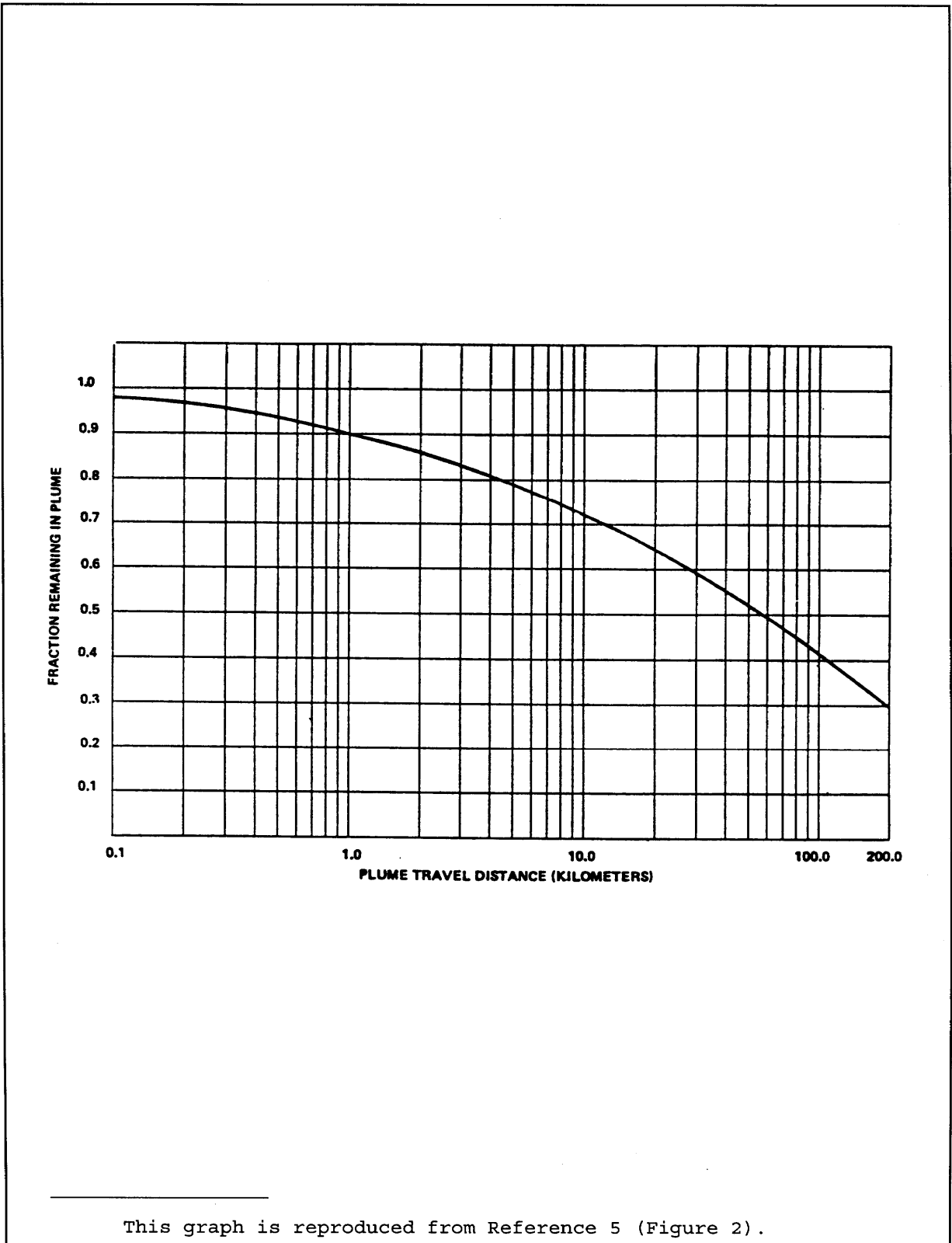

**Figure 8-3.** Plume Depletion Effect for Ground Level Releases

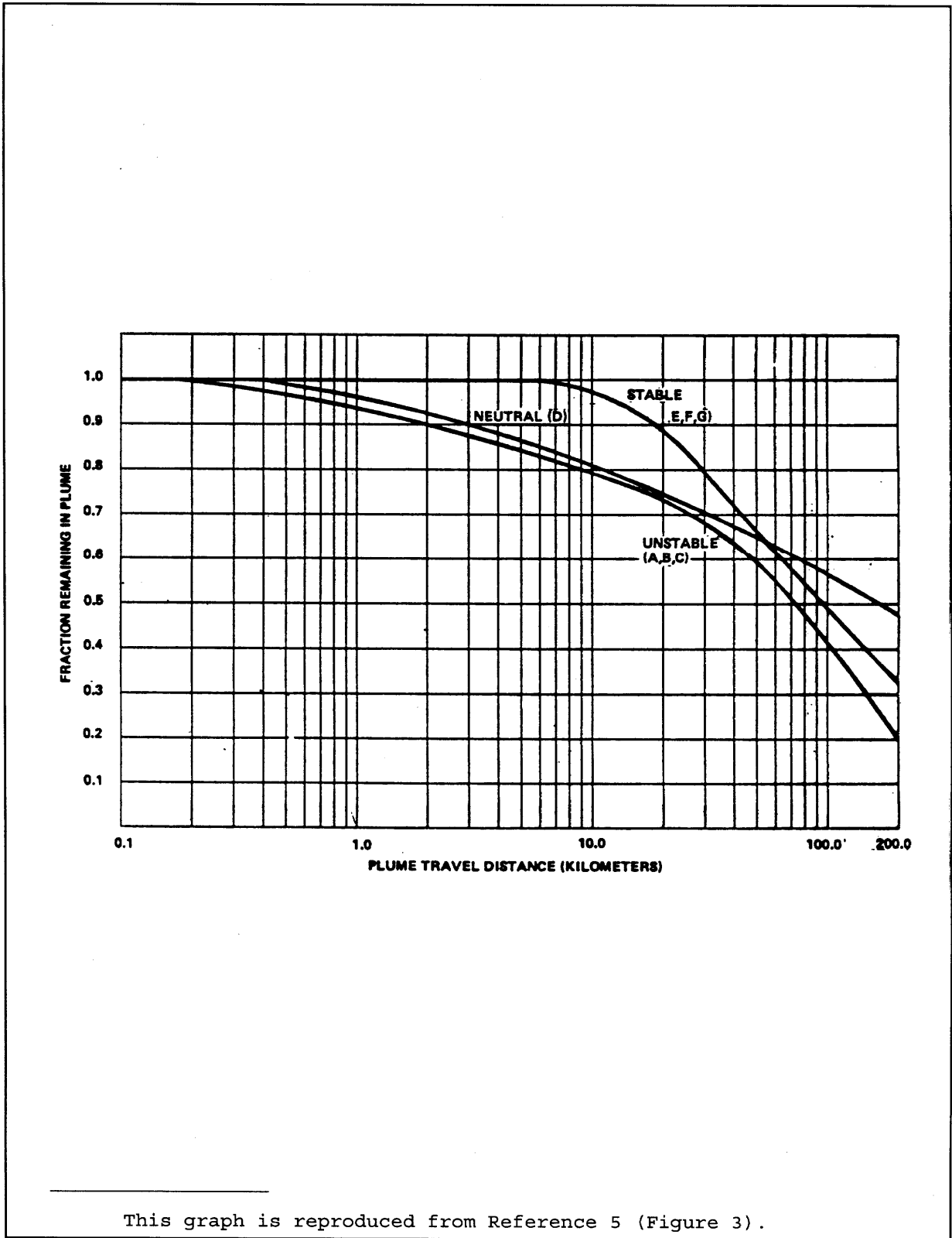
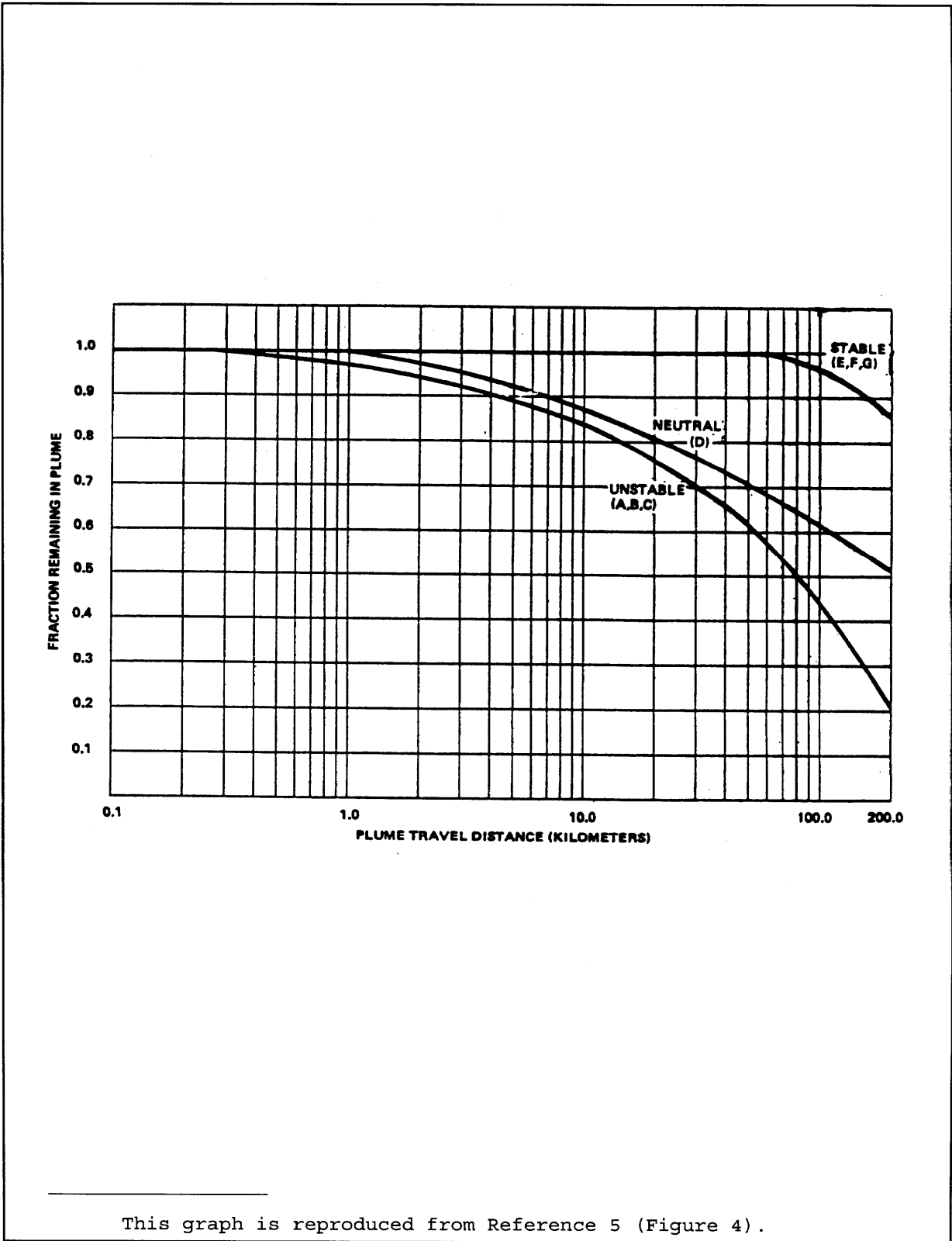
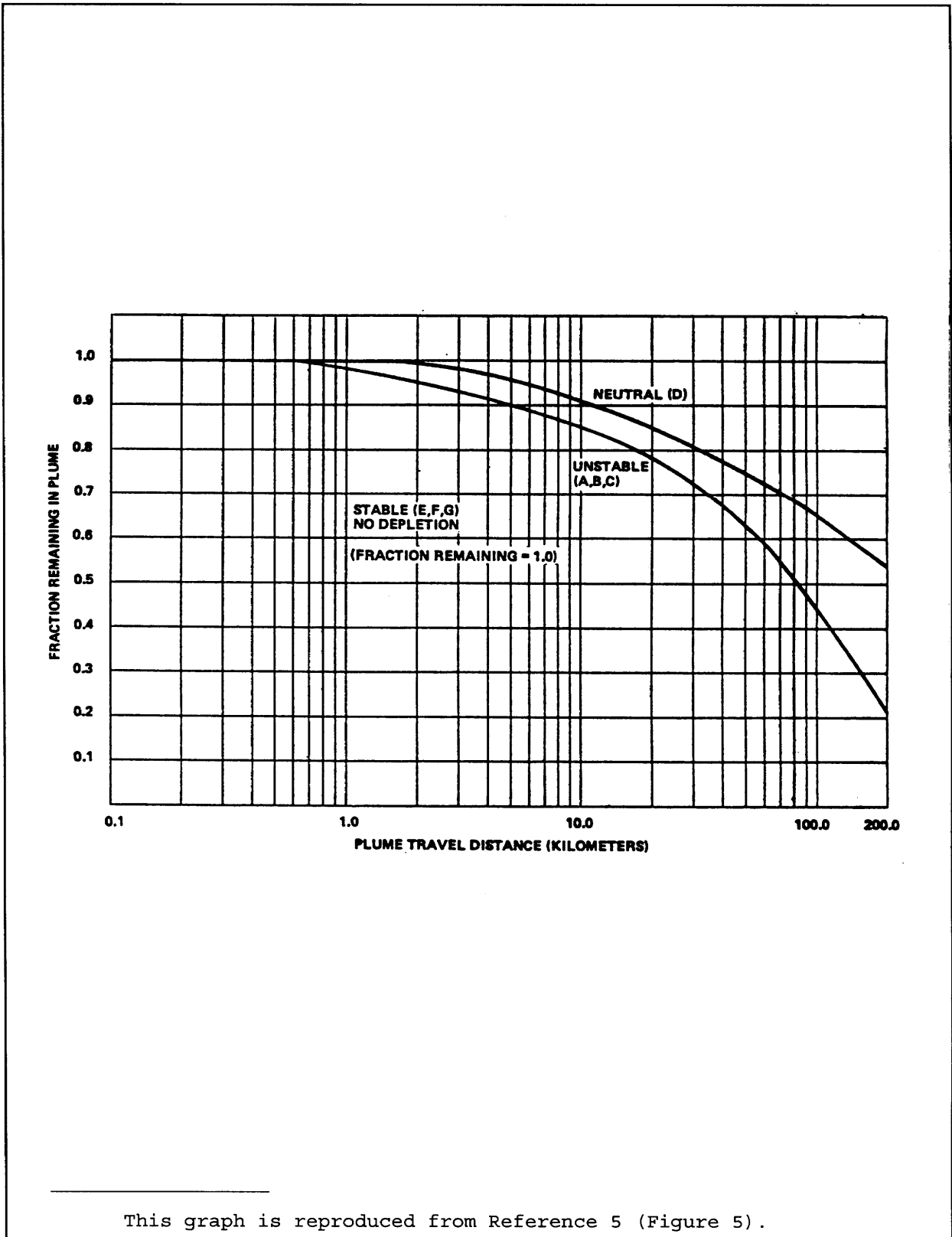

Figure 8-4. Plume Depletion Effect for 30-Meter Releases



**Figure 8-5.** Plume Depletion Effect for 60-Meter Releases



**Figure 8-6.** Plume Depletion Effect for 100-Meter Releases

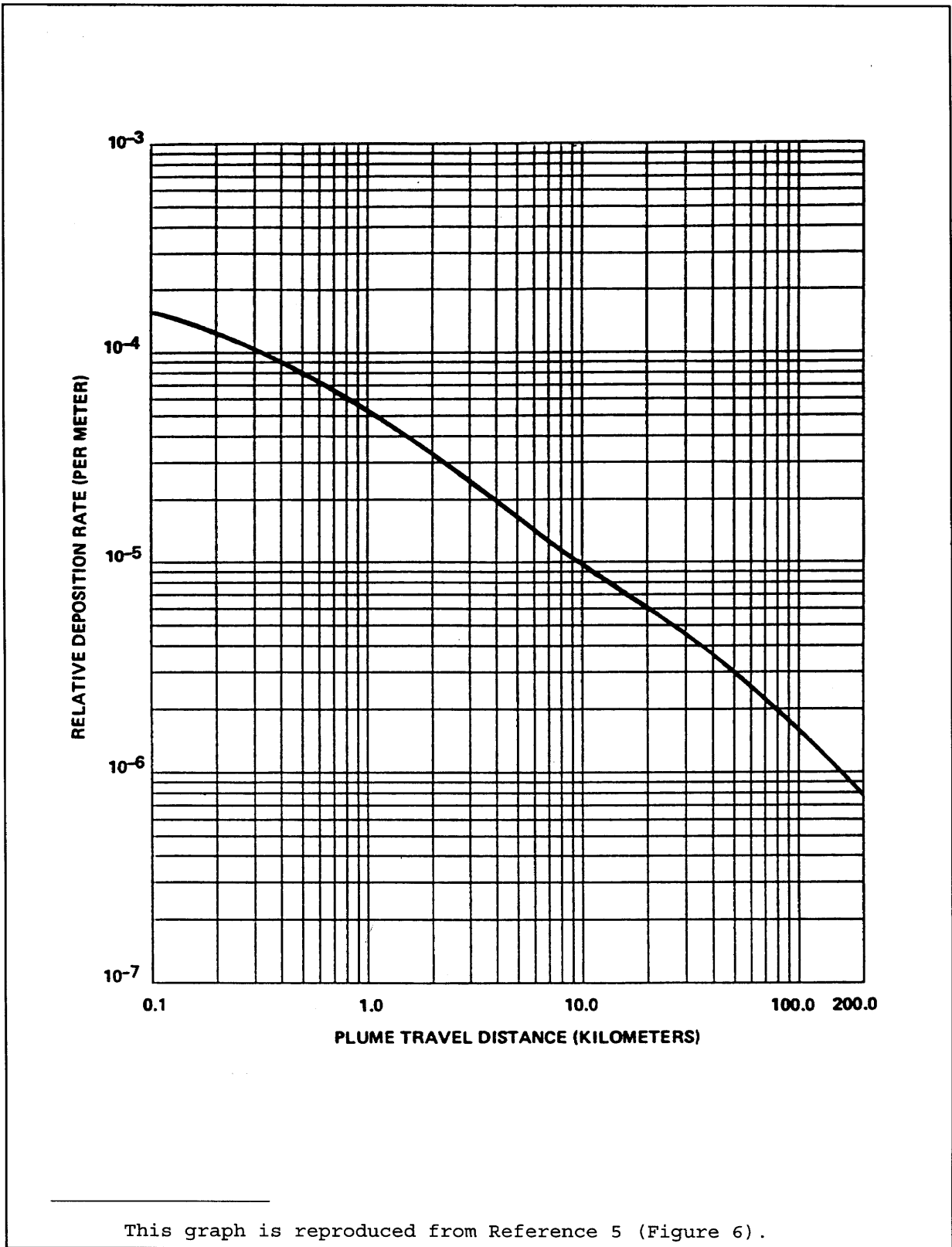

**Figure 8-7.** Relative Deposition for Ground-Level Releases

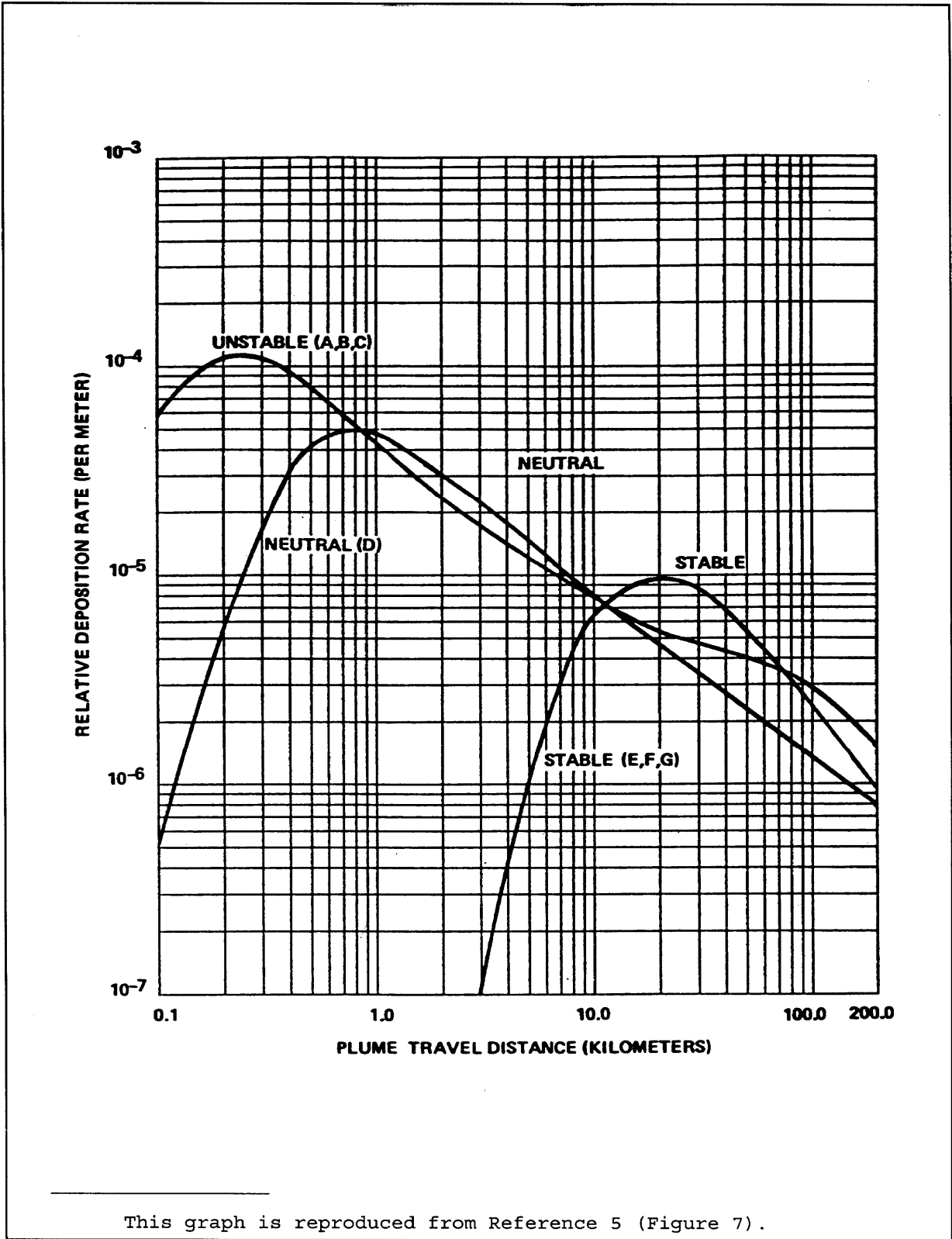

**Figure 8-8.** Relative Deposition for 30-Meter Releases

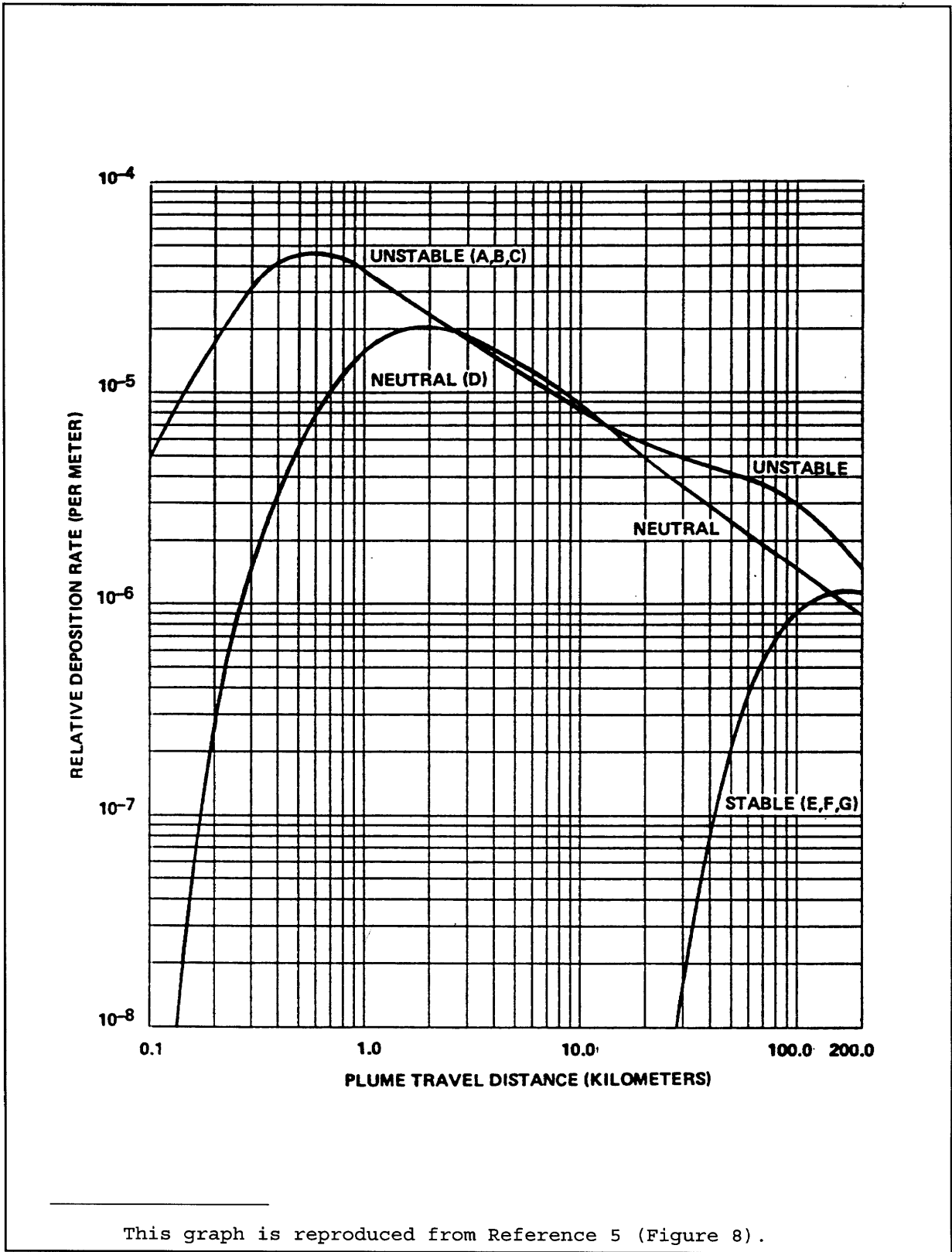
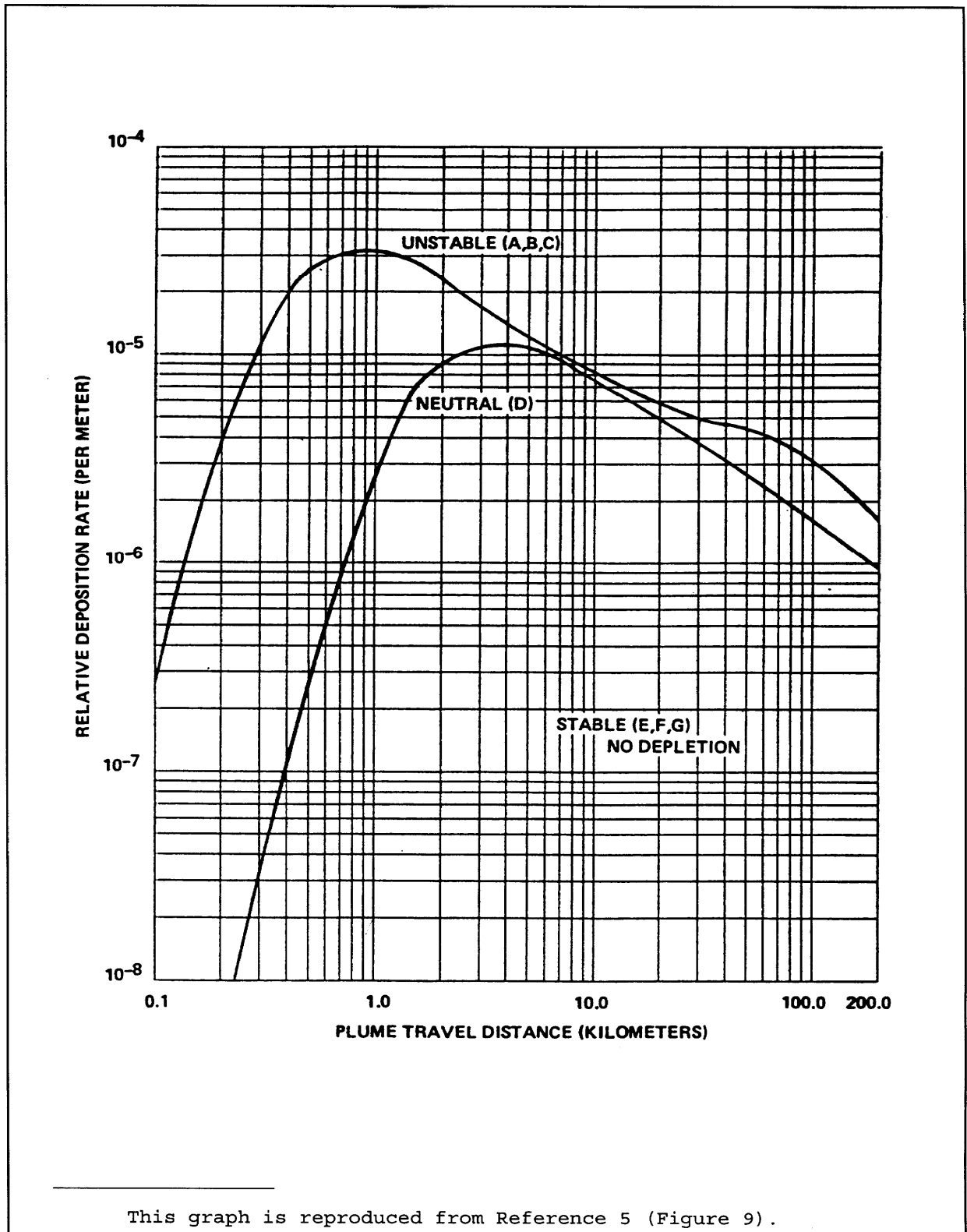

Figure 8-9. Relative Deposition for 60-Meter Releases



**Figure 8-10.** Relative Deposition for 100-Meter (or Greater) Releases

---

CHAPTER 9  
METHODS AND PARAMETERS FOR CALCULATION OF  
GASEOUS EFFLUENT PATHWAY DOSE FACTORS,  $R_{aipj}$

9.1 INHALATION PATHWAY FACTOR

For the inhalation pathway,  $R_{aipj}$  in (mrem/y) per ( $\mu\text{Ci}/\text{m}^3$ ) is calculated as follows (Reference 1, Section 5.3.1.1):

$$R_{aipj} = K_1 \cdot (BR)_a \cdot (DFA)_{aij} \quad (9.1)$$

where:

- $K_1$  = the units conversion factor:  $10^6$  pCi/ $\mu\text{Ci}$ .
- $(BR)_a$  = the breathing rate of receptor age group a, in  $\text{m}^3/\text{y}$ , from Table 9-5.
- $(DFA)_{aij}$  = the inhalation dose factor for receptor age group a, radionuclide i, and organ j, in mrem/pCi, from Table 9-7 through Table 9-10.

## 9.2 GROUND PLANE PATHWAY FACTOR

For the ground plane external exposure pathway,  $R_{aipj}$  in ( $m^2 \cdot mrem/y$ ) per ( $\mu Ci/s$ ) is calculated as follows (Reference 1, Section 5.3.1.2):

$$R_{aipj} = K_1 \cdot K_2 \cdot (SHF) \cdot (DFG)_{ij} \cdot \left( \frac{1 - e^{-\lambda_i t}}{\lambda_i} \right) \quad (9.2)$$

where:

- $K_1$  = the units conversion factor:  $10^6$  pCi/ $\mu$ Ci.
- $K_2$  = the units conversion factor: 8760 h/y.
- (SHF) = the shielding factor due to structure (dimensionless). The value used for (SHF) is 0.7, from (Reference 3, Table E-15).
- (DFG)<sub>ij</sub> = the ground plane dose factor for radionuclide  $i$  and organ  $j$ , in (mrem/h) per (pCi/ $m^2$ ), from Table 9-15. Dose factors are the same for all age groups, and those for the total body also apply to all organs other than skin.
- $\lambda_i$  = the radioactive decay constant for radionuclide  $i$ , in  $s^{-1}$ . Values of  $\lambda_i$  used in effluent calculations should be based on decay data from a recognized and current source, such as Reference 20.
- $t$  = the exposure time, in s. The value used for  $t$  is  $4.73 \times 10^8$  s (= 15 y), from (Reference 1, Section 5.3.1.2).

### 9.3 GARDEN VEGETATION PATHWAY FACTOR

For radionuclides other than tritium in the garden vegetation consumption pathway,  $R_{aipj}$  in ( $m^2 \cdot mrem/y$ ) per ( $\mu Ci/s$ ) is calculated as follows (Reference 1, Section 5.3.1.5):

$$R_{aipj} = K_1 \cdot \frac{r}{Y_v(\lambda_i + \lambda_w)} \cdot (DFL)_{aij} \cdot (U_{aL} f_L e^{-\lambda_i t_L} + U_{aS} f_g e^{-\lambda_i t_{hv}}) \quad (9.3)$$

where:

- $K_1$  = the units conversion factor:  $10^6$  pCi/ $\mu$ Ci.
- $r$  = the fraction of deposited activity retained on the edible parts of garden vegetation (dimensionless). The value used for  $r$  is 1.0 for radioiodines and 0.2 for particulates, from (Reference 3, Table E-1).
- $Y_v$  = the areal density (agricultural productivity) of growing leafy garden vegetation, in  $kg/m^2$ , from Table 9-1.
- $\lambda_i$  = the radioactive decay constant for radionuclide  $i$ , in  $s^{-1}$ . Values of  $\lambda_i$  used in effluent calculations should be based on decay data from a recognized and current source, such as Reference 20.
- $\lambda_w$  = the rate constant for removal of activity on leaf and plant surfaces by weathering, in  $s^{-1}$ , from Table 9-1.
- $(DFL)_{aij}$  = the ingestion dose factor for receptor age group  $a$ , radionuclide  $i$ , and organ  $j$ , in  $mrem/pCi$ , from Table 9-11 through Table 9-14.
- $U_{aL}$  = the consumption rate of fresh leafy garden vegetation by a receptor in age group  $a$ , in  $kg/y$ , from Table 9-5.
- $U_{aS}$  = the consumption rate of stored garden vegetation by a receptor in age group  $a$ , in  $kg/y$ , from Table 9-5.
- $f_L$  = the fraction of the annual intake of fresh leafy garden vegetation that is grown locally (dimensionless), from Table 9-1.
- $f_g$  = the fraction of the annual intake of stored garden vegetation that is grown locally (dimensionless), from Table 9-1.
- $t_L$  = the average time between harvest of fresh leafy garden vegetation and its consumption, in  $s$ , from Table 9-1.
- $t_{hv}$  = the average time between harvest of stored garden vegetation and its consumption, in  $s$ , from Table 9-1.

For tritium in the garden vegetation consumption pathway,  $R_{aipj}$  in (mrem/y) per ( $\mu\text{Ci}/\text{m}^3$ ) is calculated as follows (Reference 1, Section 5.3.1.5), based on the concentration in air rather than deposition onto the ground:

$$R_{aipj} = K_1 \cdot K_3 \cdot (DFL)_{aij} \cdot (U_{aL}f_L + U_{aS}f_g) \cdot 0.75 \cdot \left( \frac{0.5}{H} \right) \quad (9.4)$$

where:

- $K_3 =$  = the units conversion factor:  $10^3$  g/kg.
- $H =$  = the absolute humidity of atmospheric air, in  $\text{g}/\text{m}^3$ , from Table 9-1.
- $0.75 =$  = the fraction of the mass of total garden vegetation that is water (dimensionless).
- $0.5 =$  = the ratio of the specific activity of tritium in garden vegetation water to that in atmospheric water (dimensionless).

and other parameters are as defined above.

Table 9-1. Miscellaneous Parameters for the Garden Vegetation Pathway

The following parameter values are for use in calculating  $R_{aij}$  for the garden vegetation pathway only. The terms themselves are defined in section 9.3.

| Parameter   | Value   | Reference          |
|-------------|---|--------------------|
| $Y_v$       | 2.0 kg/m <sup>2</sup>   | Ref. 3, Table E-15 |
| $\lambda_w$ | 5.73 x 10 <sup>-7</sup> s <sup>-1</sup><br>(14-day half-life) | Ref. 1, page 33    |
| $f_L$       | 1.0   | Ref. 1, page 36    |
| $f_g$       | 0.76  | Ref. 1, page 33    |
| $t_L$       | 8.6 x 10 <sup>4</sup> s<br>(1 day)                            | Ref. 3, Table E-15 |
| $t_{hv}$    | 5.18 x 10 <sup>6</sup> s<br>(60 days)                         | Ref. 3, Table E-15 |
| H           | 8 g/m <sup>3</sup>  | Ref. 3             |

#### 9.4 GRASS-COW-MILK PATHWAY FACTOR

For radionuclides other than tritium in the grass-cow-milk pathway,  $R_{aijp}$  in (m<sup>2</sup>·mrem/y) per (μCi/s) is calculated as follows (Reference 1, Section 5.3.1.3):

$$R_{aijp} = K_1 \cdot \frac{r}{(\lambda_i + \lambda_w)} \cdot Q_F \cdot U_{ap} \cdot F_{mi} \cdot (DFL)_{aij} \cdot \left[ \frac{f_p f_s}{Y_p} + \frac{(1 - f_p f_s) e^{-\lambda_i t_{hm}}}{Y_s} \right] \cdot e^{-\lambda_i t_f} \quad (9.5)$$

where:

- $K_1$  = the units conversion factor: 10<sup>6</sup> pCi/μCi.
- $r$  = the fraction of deposited activity retained on the edible parts of vegetation (dimensionless). The value used for  $r$  is 1.0 for radioiodines and 0.2 for particulates, from (Reference 3, Table E-1).
- $\lambda_i$  = the radioactive decay constant for radionuclide  $i$ , in s<sup>-1</sup>. Values of  $\lambda_i$  used in effluent calculations should be based on decay data from a recognized and current source, such as Reference 20.
- $\lambda_w$  = the rate constant for removal of activity on leaf and plant surfaces by weathering, in s<sup>-1</sup>, from Table 9-2.
- $Q_F$  = the cow's consumption rate of feed, in kg/d, from Table 9-2.
- $U_{ap}$  = the consumption rate of cow milk by a receptor in age group  $a$ , in L/y, from Table 9-5.
- $F_{mi}$  = the stable element transfer coefficient applicable to radionuclide  $i$ , for cow's milk, in d/L, from Table 9-6.
- $(DFL)_{aij}$  = the ingestion dose factor for receptor age group  $a$ , radionuclide  $i$ , and organ  $j$ , in mrem/pCi, from Table 9-11 through Table 9-14.
- $f_p$  = the fraction of the year that the cow is on pasture (dimensionless), from Table 9-2.
- $f_s$  = the fraction of the cow's feed that is pasture grass while the cow is on pasture (dimensionless), from Table 9-2.
- $Y_p$  = the areal density (agricultural productivity) of growing pasture feed grass, in kg/m<sup>2</sup>, from Table 9-2.
- $Y_s$  = the areal density (agricultural productivity) of growing stored feed, in kg/m<sup>2</sup>, from Table 9-2.
- $t_{hm}$  = the transport time from harvest of stored feed to its consumption by the cow, in s, from Table 9-2.

$t_f$  = the transport time from consumption of feed by the cow, to consumption of milk by the receptor, in s, from Table 9-2.

For tritium in the grass-cow-milk pathway,  $R_{aij}$  in (mrem/y) per ( $\mu\text{Ci}/\text{m}^3$ ) is calculated as follows (Reference 1, Section 5.3.1.5), based on the concentration in air rather than deposition onto the ground:

$$R_{aij} = K_1 \cdot K_3 \cdot Q_F \cdot U_{ap} \cdot F_{mi} \cdot (DFL)_{aij} \cdot 0.75 \cdot \left( \frac{0.5}{H} \right) \quad (9.6)$$

where:

- $K_3$  = the units conversion factor:  $10^3$  g/kg.
- $H$  = the absolute humidity of atmospheric air, in  $\text{g}/\text{m}^3$ , from Table 9-2.
- 0.75 = the fraction of the mass of total vegetation that is water (dimensionless).
- 0.5 = the ratio of the specific activity of tritium in vegetation water to that in atmospheric water (dimensionless).

and other parameters are as defined above.

Table 9-2. Miscellaneous Parameters for the Grass-Cow-Milk Pathway

The following parameter values are for use in calculating  $R_{aij}$  for the grass-cow-milk pathway only. The terms themselves are defined in section 9.4.

| Parameter   | Value  | Reference          |
|-------------|--|--------------------|
| $\lambda_w$ | $5.73 \times 10^{-7} \text{ s}^{-1}$<br>(14-day half-life) | Ref. 1, page 33    |
| $Q_F$       | 50 kg/d  | Ref. 3, Table E-3  |
| $f_p$       | 1.0  | Ref. 1, page 33    |
| $f_s$       | 1.0  | Ref. 1, page 33    |
| $Y_p$       | 0.7 kg/m <sup>2</sup>                                      | Ref. 3, Table E-15 |
| $Y_s$       | 2.0 kg/m <sup>2</sup>                                      | Ref. 3, Table E-15 |
| $t_{hm}$    | $7.78 \times 10^6 \text{ s}$<br>(90 days)                  | Ref. 3, Table E-15 |
| $t_f$       | $1.73 \times 10^5 \text{ s}$<br>(2 days)                   | Ref. 3, Table E-15 |
| H           | 8 g/m <sup>3</sup>   | Ref. 3             |

## 9.5 GRASS-GOAT-MILK PATHWAY FACTOR

For radionuclides other than tritium in the grass-goat-milk pathway,  $R_{aij}$  in ( $\text{m}^2 \cdot \text{mrem}/\text{y}$ ) per ( $\mu\text{Ci}/\text{s}$ ) is calculated as follows (Reference 1, Section 5.3.1.3):

$$R_{aij} = K_1 \cdot \frac{r}{(\lambda_i + \lambda_w)} \cdot Q_F \cdot U_{ap} \cdot F_{mi} \cdot (DFL)_{aij} \cdot \left[ \frac{f_p f_s}{Y_p} + \frac{(1 - f_p f_s) e^{-\lambda_i t_{hm}}}{Y_s} \right] \cdot e^{-\lambda_i t_f} \quad (9.7)$$

where:

- $K_1$  = the units conversion factor:  $10^6$  pCi/ $\mu\text{Ci}$ .
- $r$  = the fraction of deposited activity retained on the edible parts of vegetation (dimensionless). The value used for  $r$  is 1.0 for radioiodines and 0.2 for particulates, from (Reference 3, Table E-1).
- $\lambda_i$  = the radioactive decay constant for radionuclide  $i$ , in  $\text{s}^{-1}$ . Values of  $\lambda_i$  used in effluent calculations should be based on decay data from a recognized and current source, such as Reference 20.
- $\lambda_w$  = the rate constant for removal of activity on leaf and plant surfaces by weathering, in  $\text{s}^{-1}$ , from Table 9-3.
- $Q_F$  = the goat's consumption rate of feed, in kg/d, from Table 9-3.
- $U_{ap}$  = the consumption rate of goat milk by a receptor in age group  $a$ , in L/y, from Table 9-5.
- $F_{mi}$  = the stable element transfer coefficient applicable to radionuclide  $i$ , for goat's milk, in d/L, from Table 9-6.
- $(DFL)_{aij}$  = the ingestion dose factor for receptor age group  $a$ , radionuclide  $i$ , and organ  $j$ , in mrem/pCi, from Table 9-11 through Table 9-14.
- $f_p$  = the fraction of the year that the goat is on pasture (dimensionless), from Table 9-3.
- $f_s$  = the fraction of the goat's feed that is pasture grass while the goat is on pasture (dimensionless), from Table 9-3.
- $Y_p$  = the areal density (agricultural productivity) of growing pasture feed grass, in  $\text{kg}/\text{m}^2$ , from Table 9-3.
- $Y_s$  = the areal density (agricultural productivity) of growing stored feed, in  $\text{kg}/\text{m}^2$ , from Table 9-3.
- $t_{hm}$  = the transport time from harvest of stored feed to its consumption by the goat, in s, from Table 9-3.

$t_f$  = the transport time from consumption of feed by the goat, to consumption of milk by the receptor, in s, from Table 9-3.

For tritium in the grass-goat-milk pathway,  $R_{aipj}$  in (mrem/y) per ( $\mu\text{Ci}/\text{m}^3$ ) is calculated as follows (Reference 1, Section 5.3.1.5), based on the concentration in air rather than deposition onto the ground:

$$R_{aipj} = K_1 \cdot K_3 \cdot Q_F \cdot U_{ap} \cdot F_{mi} \cdot (DFL)_{ij} \cdot 0.75 \cdot \left( \frac{0.5}{H} \right) \quad (9.8)$$

where:

$K_3$  = the units conversion factor:  $10^3$  g/kg.

$H$  = the absolute humidity of atmospheric air, in  $\text{g}/\text{m}^3$ , from Table 9-3.

0.75 = the fraction of the mass of total vegetation that is water (dimensionless).

0.5 = the ratio of the specific activity of tritium in vegetation water to that in atmospheric water (dimensionless).

and other parameters are as defined above.

Table 9-3. Miscellaneous Parameters for the Grass-Goat-Milk Pathway

The following parameter values are for use in calculating  $R_{aij}$  for the grass-goat-milk pathway only. The terms themselves are defined in section 9-5.

| Parameter   | Value  | Reference          |
|-------------|--|--------------------|
| $\lambda_w$ | $5.73 \times 10^{-7} \text{ s}^{-1}$<br>(14-day half-life) | Ref. 1, page 33    |
| $Q_F$       | 6 kg/d   | Ref. 3, Table E-3  |
| $f_p$       | 1.0  | Ref. 1, page 33    |
| $f_s$       | 1.0  | Ref. 1, page 33    |
| $Y_p$       | 0.7 kg/m <sup>2</sup>                                      | Ref. 3, Table E-15 |
| $Y_s$       | 2.0 kg/m <sup>2</sup>                                      | Ref. 3, Table E-15 |
| $t_{hm}$    | $7.78 \times 10^6 \text{ s}$<br>(90 days)                  | Ref. 3, Table E-15 |
| $t_f$       | $1.73 \times 10^5 \text{ s}$<br>(2 days)                   | Ref. 3, Table E-15 |
| H           | 8 g/m <sup>3</sup>   | Ref. 3             |

## 9.6 GRASS-COW-MEAT PATHWAY FACTOR

For radionuclides other than tritium in the grass-cow-meat pathway,  $R_{aij}$  in ( $m^2 \cdot mrem/y$ ) per ( $\mu Ci/s$ ) is calculated as follows (Reference 1, Section 5.3.1.4):

$$R_{aij} = K_1 \cdot \frac{r}{(\lambda_i + \lambda_w)} \cdot Q_F \cdot U_{ap} \cdot F_{fi} \cdot (DFL)_{aij} \cdot \left[ \frac{f_p f_s}{Y_p} + \frac{(1 - f_p f_s) e^{-\lambda_i t_{hm}}}{Y_s} \right] \cdot e^{-\lambda_i t_f} \quad (9.9)$$

where:

- $K_1 =$  the units conversion factor:  $10^6$  pCi/ $\mu$ Ci.
- $r =$  the fraction of deposited activity retained on the edible parts of vegetation (dimensionless). The value used for  $r$  is 1.0 for radioiodines and 0.2 for particulates, from (Reference 3, Table E-1).
- $\lambda_i =$  the radioactive decay constant for radionuclide  $i$ , in  $s^{-1}$ . Values of  $\lambda_i$  used in effluent calculations should be based on decay data from a recognized and current source, such as Reference 20.
- $\lambda_w =$  the rate constant for removal of activity on leaf and plant surfaces by weathering, in  $s^{-1}$ , from Table 9-4.
- $Q_F =$  the cow's consumption rate of feed, in kg/d, from Table 9-4.
- $U_{ap} =$  the consumption rate of meat by a receptor in age group  $a$ , in kg/y, from Table 9-5.
- $F_{fi} =$  the stable element transfer coefficient applicable to radionuclide  $i$ , for meat, in d/kg, from Table 9-6.
- $(DFL)_{aij} =$  the ingestion dose factor for receptor age group  $a$ , radionuclide  $i$ , and organ  $j$ , in mrem/pCi, from Table 9-11 through Table 9-14.
- $f_p =$  the fraction of the year that the cow is on pasture (dimensionless), from Table 9-4.
- $f_s =$  the fraction of the cow's feed that is pasture grass while the cow is on pasture (dimensionless), from Table 9-4.
- $Y_p =$  the areal density (agricultural productivity) of growing pasture feed grass, in kg/m<sup>2</sup>, from Table 9-4.
- $Y_s =$  the areal density (agricultural productivity) of growing stored feed, in kg/m<sup>2</sup>, from Table 9-4.
- $t_{hm} =$  the transport time from harvest of stored feed to its consumption by the cow, in s, from Table 9-4.

$t_f$  = the transport time from consumption of feed by the cow, to consumption of meat by the receptor, in s, from Table 9-4.

For tritium in the grass-cow-meat pathway,  $R_{aij}$  in (mrem/y) per ( $\mu\text{Ci}/\text{m}^3$ ) is calculated as follows (Reference 1, Section 5.3.1.4), based on the concentration in air rather than deposition onto the ground:

$$R_{aij} = K_1 \cdot K_3 \cdot Q_F \cdot U_{ap} \cdot F_{fi} \cdot (DFL)_{aij} \cdot 0.75 \cdot \left( \frac{0.5}{H} \right) \quad (9.10)$$

where:

$K_3$  = the units conversion factor:  $10^3$  g/kg.

$H$  = the absolute humidity of atmospheric air, in  $\text{g}/\text{m}^3$ , from Table 9-4.

0.75 = the fraction of the mass of total vegetation that is water (dimensionless).

0.5 = the ratio of the specific activity of tritium in vegetation water to that in atmospheric water (dimensionless).

and other parameters are as defined above.

Table 9-4. Miscellaneous Parameters for the Grass-Cow-Meat Pathway

The following parameter values are for use in calculating  $R_{aij}$  for the grass-cow-meat pathway only. The terms themselves are defined in section 9-6.

| Parameter   | Value  | Reference          |
|-------------|--|--------------------|
| $\lambda_w$ | $5.73 \times 10^{-7} \text{ s}^{-1}$<br>(14-day half-life) | Ref. 1, page 33    |
| $Q_F$       | 50 kg/d  | Ref. 3, Table E-3  |
| $f_p$       | 1.0  | Ref. 1, page 33    |
| $f_s$       | 1.0  | Ref. 1, page 33    |
| $Y_p$       | 0.7 kg/m <sup>2</sup>                                      | Ref. 3, Table E-15 |
| $Y_s$       | 2.0 kg/m <sup>2</sup>                                      | Ref. 3, Table E-15 |
| $t_{hm}$    | $7.78 \times 10^6 \text{ s}$<br>(90 days)                  | Ref. 3, Table E-15 |
| $t_f$       | $1.73 \times 10^6 \text{ s}$<br>(20 days)                  | Ref. 3, Table E-15 |
| H           | 8 g/m <sup>3</sup>   | Ref. 3             |

Table 9-5. Individual Usage Factors

| Usage Factor  | Receptor Age Group |       |          |       |
|---|--------------------|-------|----------|-------|
|   | Infant             | Child | Teenager | Adult |
| Milk Consumption Rate, $U_{ap}$<br>(L/y)                              | 330                | 330   | 400      | 310   |
| Meat Consumption Rate, $U_{ap}$<br>(kg/y)                             | 0                  | 41    | 65       | 110   |
| Fresh Leafy Garden Vegetation<br>Consumption Rate, $U_{aL}$<br>(kg/y) | 0                  | 26    | 42       | 64    |
| Stored Garden Vegetation<br>Consumption Rate, $U_{aS}$<br>(kg/y)      | 0                  | 520   | 630      | 520   |
| Breathing Rate, $(BR)_a$<br>(m <sup>3</sup> /y)                       | 1400               | 3700  | 8000     | 8000  |

All values are from Reference 3, Table E-5.

Table 9-6. Stable Element Transfer Data

| Element | Cow Milk     | Goat Milk    | Meat          |
|---------|--------------|--------------|---------------|
|         | $F_m$ (d/L)* | $F_m$ (d/L)+ | $F_f$ (d/kg)* |
| H       | 1.0 E-02     | 1.7 E-01     | 1.2 E-02      |
| C       | 1.2 E-02     | 1.0 E-01     | 3.1 E-02      |
| Na      | 4.0 E-02     | 4.0 E-02     | 3.0 E-02      |
| P       | 2.5 E-02     | 2.5 E-01     | 4.6 E-02      |
| Cr      | 2.2 E-03     | 2.2 E-03     | 2.4 E-03      |
| Mn      | 2.5 E-04     | 2.5 E-04     | 8.0 E-04      |
| Fe      | 1.2 E-03     | 1.3 E-04     | 4.0 E-02      |
| Co      | 1.0 E-03     | 1.0 E-03     | 1.3 E-02      |
| Ni      | 6.7 E-03     | 6.7 E-03     | 5.3 E-02      |
| Cu      | 1.4 E-02     | 1.3 E-02     | 8.0 E-03      |
| Zn      | 3.9 E-02     | 3.9 E-02     | 3.0 E-02      |
| Br      | 5.0 E-02     | 5.0 E-02     | 2.6 E-02      |
| Rb      | 3.0 E-02     | 3.0 E-02     | 3.1 E-02      |
| Sr      | 8.0 E-04     | 1.4 E-02     | 6.0 E-04      |
| Y       | 1.0 E-05     | 1.0 E-05     | 4.6 E-03      |
| Zr      | 5.0 E-06     | 5.0 E-06     | 3.4 E-02      |
| Nb      | 2.5 E-03     | 2.5 E-03     | 2.8 E-01      |
| Mo      | 7.5 E-03     | 7.5 E-03     | 8.0 E-03      |
| Tc      | 2.5 E-02     | 2.5 E-02     | 4.0 E-01      |
| Ru      | 1.0 E-06     | 1.0 E-06     | 4.0 E-01      |
| Rh      | 1.0 E-02     | 1.0 E-02     | 1.5 E-03      |
| Ag      | 5.0 E-02     | 5.0 E-02     | 1.7 E-02      |
| Sb      | 1.5 E-03     | 1.5 E-03     | 4.0 E-03      |
| Te      | 1.0 E-03     | 1.0 E-03     | 7.7 E-02      |
| I       | 6.0 E-03     | 6.0 E-02     | 2.9 E-03      |
| Cs      | 1.2 E-02     | 3.0 E-01     | 4.0 E-03      |
| Ba      | 4.0 E-04     | 4.0 E-04     | 3.2 E-03      |
| La      | 5.0 E-06     | 5.0 E-06     | 2.0 E-04      |
| Ce      | 1.0 E-04     | 1.0 E-04     | 1.2 E-03      |
| Pr      | 5.0 E-06     | 5.0 E-06     | 4.7 E-03      |
| Nd      | 5.0 E-06     | 5.0 E-06     | 3.3 E-03      |
| W       | 5.0 E-04     | 5.0 E-04     | 1.3 E-03      |
| Np      | 5.0 E-06     | 5.0 E-06     | 2.0 E-04      |

\* - Values from Reference 3 (Table E-1) except as follows: Reference 2 (Table C-5) for Br and Sb.

+ - Values from Reference 3, Table E-2 for H, C, P, Fe, Cu, Sr, I, and Cs in goat milk, and Table E-1 for all other elements in cow milk, except as follows: Reference 2 (Table C-5) for Br and Sb in cow milk.

Table 9-7. Inhalation Dose Factors for the Infant Age Group

| Nuclide | Bone     | Liver    | T.Body   | Thyroid  | Kidney   | Lung     | GI-LLI   |
|---------|----------|----------|----------|----------|----------|----------|----------|
| H-3     | No Data  | 4.62E-07 | 4.62E-07 | 4.62E-07 | 4.62E-07 | 4.62E-07 | 4.62E-07 |
| C-14    | 1.89E-05 | 3.79E-06 | 3.79E-06 | 3.79E-06 | 3.79E-06 | 3.79E-06 | 3.79E-06 |
| Na-24   | 7.54E-06 | 7.54E-06 | 7.54E-06 | 7.54E-06 | 7.54E-06 | 7.54E-06 | 7.54E-06 |
| P-32    | 1.45E-03 | 8.03E-05 | 5.53E-05 | No Data  | No Data  | No Data  | 1.15E-05 |
| Cr-51   | No Data  | No Data  | 6.39E-08 | 4.11E-08 | 9.45E-09 | 9.17E-06 | 2.55E-07 |
| Mn-54   | No Data  | 1.81E-05 | 3.56E-06 | No Data  | 3.56E-06 | 7.14E-04 | 5.04E-06 |
| Mn-56   | No Data  | 1.10E-09 | 1.58E-10 | No Data  | 7.86E-10 | 8.95E-06 | 5.12E-05 |
| Fe-55   | 1.41E-05 | 8.39E-06 | 2.38E-06 | No Data  | No Data  | 6.21E-05 | 7.82E-07 |
| Fe-59   | 9.69E-06 | 1.68E-05 | 6.77E-06 | No Data  | No Data  | 7.25E-04 | 1.77E-05 |
| Co-58   | No Data  | 8.71E-07 | 1.30E-06 | No Data  | No Data  | 5.55E-04 | 7.95E-06 |
| Co-60   | No Data  | 5.73E-06 | 8.41E-06 | No Data  | No Data  | 3.22E-03 | 2.28E-05 |
| Ni-63   | 2.42E-04 | 1.46E-05 | 8.29E-06 | No Data  | No Data  | 1.49E-04 | 1.73E-06 |
| Ni-65   | 1.71E-09 | 2.03E-10 | 8.79E-11 | No Data  | No Data  | 5.80E-06 | 3.58E-05 |
| Cu-64   | No Data  | 1.34E-09 | 5.53E-10 | No Data  | 2.84E-09 | 6.64E-06 | 1.07E-05 |
| Zn-65   | 1.38E-05 | 4.47E-05 | 2.22E-05 | No Data  | 2.32E-05 | 4.62E-04 | 3.67E-05 |
| Zn-69   | 3.85E-11 | 6.91E-11 | 5.13E-12 | No Data  | 2.87E-11 | 1.05E-06 | 9.44E-06 |
| Br-83   | No Data  | No Data  | 2.72E-07 | No Data  | No Data  | No Data  | No Data  |
| Br-84   | No Data  | No Data  | 2.86E-07 | No Data  | No Data  | No Data  | No Data  |
| Br-85   | No Data  | No Data  | 1.46E-08 | No Data  | No Data  | No Data  | No Data  |
| Rb-86   | No Data  | 1.36E-04 | 6.30E-05 | No Data  | No Data  | No Data  | 2.17E-06 |
| Rb-88   | No Data  | 3.98E-07 | 2.05E-07 | No Data  | No Data  | No Data  | 2.42E-07 |
| Rb-89   | No Data  | 2.29E-07 | 1.47E-07 | No Data  | No Data  | No Data  | 4.87E-08 |
| Sr-89   | 2.84E-04 | No Data  | 8.15E-06 | No Data  | No Data  | 1.45E-03 | 4.57E-05 |
| Sr-90   | 2.92E-02 | No Data  | 1.85E-03 | No Data  | No Data  | 8.03E-03 | 9.36E-05 |
| Sr-91   | 6.83E-08 | No Data  | 2.47E-09 | No Data  | No Data  | 3.76E-05 | 5.24E-05 |

All values are in (mrem/pCi inhaled). They are obtained from Reference 3 (Table E-10). Neither Reference 2 nor Reference 3 contains data for Rh-105, Sb-124, or Sb-125.

Table 9-7 (contd). Inhalation Dose Factors for the Infant Age Group

| Nuclide | Bone     | Liver    | T.Body   | Thyroid  | Kidney   | Lung     | GI-LLI   |
|---------|----------|----------|----------|----------|----------|----------|----------|
| Sr-92   | 7.50E-09 | No Data  | 2.79E-10 | No Data  | No Data  | 1.70E-05 | 1.00E-04 |
| Y-90    | 2.35E-06 | No Data  | 6.30E-08 | No Data  | No Data  | 1.92E-04 | 7.43E-05 |
| Y-91m   | 2.91E-10 | No Data  | 9.90E-12 | No Data  | No Data  | 1.99E-06 | 1.68E-06 |
| Y-91    | 4.20E-04 | No Data  | 1.12E-05 | No Data  | No Data  | 1.75E-03 | 5.02E-05 |
| Y-92    | 1.17E-08 | No Data  | 3.29E-10 | No Data  | No Data  | 1.75E-05 | 9.04E-05 |
| Y-93    | 1.07E-07 | No Data  | 2.91E-09 | No Data  | No Data  | 5.46E-05 | 1.19E-04 |
| Zr-95   | 8.24E-05 | 1.99E-05 | 1.45E-05 | No Data  | 2.22E-05 | 1.25E-03 | 1.55E-05 |
| Zr-97   | 1.07E-07 | 1.83E-08 | 8.36E-09 | No Data  | 1.85E-08 | 7.88E-05 | 1.00E-04 |
| Nb-95   | 1.12E-05 | 4.59E-06 | 2.70E-06 | No Data  | 3.37E-06 | 3.42E-04 | 9.05E-06 |
| Mo-99   | No Data  | 1.18E-07 | 2.31E-08 | No Data  | 1.89E-07 | 9.63E-05 | 3.48E-05 |
| Tc-99m  | 9.98E-13 | 2.06E-12 | 2.66E-11 | No Data  | 2.22E-11 | 5.79E-07 | 1.45E-06 |
| Tc-101  | 4.65E-14 | 5.88E-14 | 5.80E-13 | No Data  | 6.99E-13 | 4.17E-07 | 6.03E-07 |
| Ru-103  | 1.44E-06 | No Data  | 4.85E-07 | No Data  | 3.03E-06 | 3.94E-04 | 1.15E-05 |
| Ru-105  | 8.74E-10 | No Data  | 2.93E-10 | No Data  | 6.42E-10 | 1.12E-05 | 3.46E-05 |
| Ru-106  | 6.20E-05 | No Data  | 7.77E-06 | No Data  | 7.61E-05 | 8.26E-03 | 1.17E-04 |
| Rh-105  | No Data  | No Data  | No Data  | No Data  | No Data  | No Data  | No Data  |
| Ag-110m | 7.13E-06 | 5.16E-06 | 3.57E-06 | No Data  | 7.80E-06 | 2.62E-03 | 2.36E-05 |
| Sb-124  | No Data  | No Data  | No Data  | No Data  | No Data  | No Data  | No Data  |
| Sb-125  | No Data  | No Data  | No Data  | No Data  | No Data  | No Data  | No Data  |
| Te-125m | 3.40E-06 | 1.42E-06 | 4.70E-07 | 1.16E-06 | No Data  | 3.19E-04 | 9.22E-06 |
| Te-127m | 1.19E-05 | 4.93E-06 | 1.48E-06 | 3.48E-06 | 2.68E-05 | 9.37E-04 | 1.95E-05 |
| Te-127  | 1.59E-09 | 6.81E-10 | 3.49E-10 | 1.32E-09 | 3.47E-09 | 7.39E-06 | 1.74E-05 |
| Te-129m | 1.01E-05 | 4.35E-06 | 1.59E-06 | 3.91E-06 | 2.27E-05 | 1.20E-03 | 4.93E-05 |
| Te-129  | 5.63E-11 | 2.48E-11 | 1.34E-11 | 4.82E-11 | 1.25E-10 | 2.14E-06 | 1.88E-05 |
| Te-131m | 7.62E-08 | 3.93E-08 | 2.59E-08 | 6.38E-08 | 1.89E-07 | 1.42E-04 | 8.51E-05 |
| Te-131  | 1.24E-11 | 5.87E-12 | 3.57E-12 | 1.13E-11 | 2.85E-11 | 1.47E-06 | 5.87E-06 |

Table 9-7 (contd). Inhalation Dose Factors for the Infant Age Group

| Nuclide | Bone     | Liver    | T.Body   | Thyroid  | Kidney   | Lung     | GI-LLI   |
|---------|----------|----------|----------|----------|----------|----------|----------|
| Te-132  | 2.66E-07 | 1.69E-07 | 1.26E-07 | 1.99E-07 | 7.39E-07 | 2.43E-04 | 3.15E-05 |
| I-130   | 4.54E-06 | 9.91E-06 | 3.98E-06 | 1.14E-03 | 1.09E-05 | No Data  | 1.42E-06 |
| I-131   | 2.71E-05 | 3.17E-05 | 1.40E-05 | 1.06E-02 | 3.70E-05 | No Data  | 7.56E-07 |
| I-132   | 1.21E-06 | 2.53E-06 | 8.99E-07 | 1.21E-04 | 2.82E-06 | No Data  | 1.36E-06 |
| I-133   | 9.46E-06 | 1.37E-05 | 4.00E-06 | 2.54E-03 | 1.60E-05 | No Data  | 1.54E-06 |
| I-134   | 6.58E-07 | 1.34E-06 | 4.75E-07 | 3.18E-05 | 1.49E-06 | No Data  | 9.21E-07 |
| I-135   | 2.76E-06 | 5.43E-06 | 1.98E-06 | 4.97E-04 | 6.05E-06 | No Data  | 1.31E-06 |
| Cs-134  | 2.83E-04 | 5.02E-04 | 5.32E-05 | No Data  | 1.36E-04 | 5.69E-05 | 9.53E-07 |
| Cs-136  | 3.45E-05 | 9.61E-05 | 3.78E-05 | No Data  | 4.03E-05 | 8.40E-06 | 1.02E-06 |
| Cs-137  | 3.92E-04 | 4.37E-04 | 3.25E-05 | No Data  | 1.23E-04 | 5.09E-05 | 9.53E-07 |
| Cs-138  | 3.61E-07 | 5.58E-07 | 2.84E-07 | No Data  | 2.93E-07 | 4.67E-08 | 6.26E-07 |
| Ba-139  | 1.06E-09 | 7.03E-13 | 3.07E-11 | No Data  | 4.23E-13 | 4.25E-06 | 3.64E-05 |
| Ba-140  | 4.00E-05 | 4.00E-08 | 2.07E-06 | No Data  | 9.59E-09 | 1.14E-03 | 2.74E-05 |
| Ba-141  | 1.12E-10 | 7.70E-14 | 3.55E-12 | No Data  | 4.64E-14 | 2.12E-06 | 3.39E-06 |
| Ba-142  | 2.84E-11 | 2.36E-14 | 1.40E-12 | No Data  | 1.36E-14 | 1.11E-06 | 4.95E-07 |
| La-140  | 3.61E-07 | 1.43E-07 | 3.68E-08 | No Data  | No Data  | 1.20E-04 | 6.06E-05 |
| La-142  | 7.36E-10 | 2.69E-10 | 6.46E-11 | No Data  | No Data  | 5.87E-06 | 4.25E-05 |
| Ce-141  | 1.98E-05 | 1.19E-05 | 1.42E-06 | No Data  | 3.75E-06 | 3.69E-04 | 1.54E-05 |
| Ce-143  | 2.09E-07 | 1.38E-07 | 1.58E-08 | No Data  | 4.03E-08 | 8.30E-05 | 3.55E-05 |
| Ce-144  | 2.28E-03 | 8.65E-04 | 1.26E-04 | No Data  | 3.84E-04 | 7.03E-03 | 1.06E-04 |
| Pr-143  | 1.00E-05 | 3.74E-06 | 4.99E-07 | No Data  | 1.41E-06 | 3.09E-04 | 2.66E-05 |
| Pr-144  | 3.42E-11 | 1.32E-11 | 1.72E-12 | No Data  | 4.80E-12 | 1.15E-06 | 3.06E-06 |
| Nd-147  | 5.67E-06 | 5.81E-06 | 3.57E-07 | No Data  | 2.25E-06 | 2.30E-04 | 2.23E-05 |
| W-187   | 9.26E-09 | 6.44E-09 | 2.23E-09 | No Data  | No Data  | 2.83E-05 | 2.54E-05 |
| Np-239  | 2.65E-07 | 2.37E-08 | 1.34E-08 | No Data  | 4.73E-08 | 4.25E-05 | 1.78E-05 |

Table 9-8. Inhalation Dose Factors for the Child Age Group

| Nuclide | Bone     | Liver    | T. Body  | Thyroid  | Kidney   | Lung     | GI-LLI   |
|---------|----------|----------|----------|----------|----------|----------|----------|
| H-3     | No Data  | 3.04E-07 | 3.04E-07 | 3.04E-07 | 3.04E-07 | 3.04E-07 | 3.04E-07 |
| C-14    | 9.70E-06 | 1.82E-06 | 1.82E-06 | 1.82E-06 | 1.82E-06 | 1.82E-06 | 1.82E-06 |
| Na-24   | 4.35E-06 | 4.35E-06 | 4.35E-06 | 4.35E-06 | 4.35E-06 | 4.35E-06 | 4.35E-06 |
| P-32    | 7.04E-04 | 3.09E-05 | 2.67E-05 | No Data  | No Data  | No Data  | 1.14E-05 |
| Cr-51   | No Data  | No Data  | 4.17E-08 | 2.31E-08 | 6.57E-09 | 4.59E-06 | 2.93E-07 |
| Mn-54   | No Data  | 1.16E-05 | 2.57E-06 | No Data  | 2.71E-06 | 4.26E-04 | 6.19E-06 |
| Mn-56   | No Data  | 4.48E-10 | 8.43E-11 | No Data  | 4.52E-10 | 3.55E-06 | 3.33E-05 |
| Fe-55   | 1.28E-05 | 6.80E-06 | 2.10E-06 | No Data  | No Data  | 3.00E-05 | 7.75E-07 |
| Fe-59   | 5.59E-06 | 9.04E-06 | 4.51E-06 | No Data  | No Data  | 3.43E-04 | 1.91E-05 |
| Co-58   | No Data  | 4.79E-07 | 8.55E-07 | No Data  | No Data  | 2.99E-04 | 9.29E-06 |
| Co-60   | No Data  | 3.55E-06 | 6.12E-06 | No Data  | No Data  | 1.91E-03 | 2.60E-05 |
| Ni-63   | 2.22E-04 | 1.25E-05 | 7.56E-06 | No Data  | No Data  | 7.43E-05 | 1.71E-06 |
| Ni-65   | 8.08E-10 | 7.99E-11 | 4.44E-11 | No Data  | No Data  | 2.21E-06 | 2.27E-05 |
| Cu-64   | No Data  | 5.39E-10 | 2.90E-10 | No Data  | 1.63E-09 | 2.59E-06 | 9.92E-06 |
| Zn-65   | 1.15E-05 | 3.06E-05 | 1.90E-05 | No Data  | 1.93E-05 | 2.69E-04 | 4.41E-06 |
| Zn-69   | 1.81E-11 | 2.61E-11 | 2.41E-12 | No Data  | 1.58E-11 | 3.84E-07 | 2.75E-06 |
| Br-83   | No Data  | No Data  | 1.28E-07 | No Data  | No Data  | No Data  | No Data  |
| Br-84   | No Data  | No Data  | 1.48E-07 | No Data  | No Data  | No Data  | No Data  |
| Br-85   | No Data  | No Data  | 6.84E-09 | No Data  | No Data  | No Data  | No Data  |
| Rb-86   | No Data  | 5.36E-05 | 3.09E-05 | No Data  | No Data  | No Data  | 2.16E-06 |
| Rb-88   | No Data  | 1.52E-07 | 9.90E-08 | No Data  | No Data  | No Data  | 4.66E-09 |
| Rb-89   | No Data  | 9.33E-08 | 7.83E-08 | No Data  | No Data  | No Data  | 5.11E-10 |
| Sr-89   | 1.62E-04 | No Data  | 4.66E-06 | No Data  | No Data  | 5.83E-04 | 4.52E-05 |
| Sr-90   | 2.73E-02 | No Data  | 1.74E-03 | No Data  | No Data  | 3.99E-03 | 9.28E-05 |
| Sr-91   | 3.28E-08 | No Data  | 1.24E-09 | No Data  | No Data  | 1.44E-05 | 4.70E-05 |

All values are in (mrem/pCi inhaled). They are obtained from Reference 3 (Table E-9). Neither Reference 2 nor Reference 3 contains data for Rh-105, Sb-124, or Sb-125.

Table 9-8 (contd). Inhalation Dose Factors for the Child Age Group

| Nuclide | Bone     | Liver    | T.Body   | Thyroid  | Kidney   | Lung     | GI-LLI   |
|---------|----------|----------|----------|----------|----------|----------|----------|
| Sr-92   | 3.54E-09 | No Data  | 1.42E-10 | No Data  | No Data  | 6.49E-06 | 6.55E-05 |
| Y-90    | 1.11E-06 | No Data  | 2.99E-08 | No Data  | No Data  | 7.07E-05 | 7.24E-05 |
| Y-91m   | 1.37E-10 | No Data  | 4.98E-12 | No Data  | No Data  | 7.60E-07 | 4.64E-07 |
| Y-91    | 2.47E-04 | No Data  | 6.59E-06 | No Data  | No Data  | 7.10E-04 | 4.97E-05 |
| Y-92    | 5.50E-09 | No Data  | 1.57E-10 | No Data  | No Data  | 6.46E-06 | 6.46E-05 |
| Y-93    | 5.04E-08 | No Data  | 1.38E-09 | No Data  | No Data  | 2.01E-05 | 1.05E-04 |
| Zr-95   | 5.13E-05 | 1.13E-05 | 1.00E-05 | No Data  | 1.61E-05 | 6.03E-04 | 1.65E-05 |
| Zr-97   | 5.07E-08 | 7.34E-09 | 4.32E-09 | No Data  | 1.05E-08 | 3.06E-05 | 9.49E-05 |
| Nb-95   | 6.35E-06 | 2.48E-06 | 1.77E-06 | No Data  | 2.33E-06 | 1.66E-04 | 1.00E-05 |
| Mo-99   | No Data  | 4.66E-08 | 1.15E-08 | No Data  | 1.06E-07 | 3.66E-05 | 3.42E-05 |
| Tc-99m  | 4.81E-13 | 9.41E-13 | 1.56E-11 | No Data  | 1.37E-11 | 2.57E-07 | 1.30E-06 |
| Tc-101  | 2.19E-14 | 2.30E-14 | 2.91E-13 | No Data  | 3.92E-13 | 1.58E-07 | 4.41E-09 |
| Ru-103  | 7.55E-07 | No Data  | 2.90E-07 | No Data  | 1.90E-06 | 1.79E-04 | 1.21E-05 |
| Ru-105  | 4.13E-10 | No Data  | 1.50E-10 | No Data  | 3.63E-10 | 4.30E-06 | 2.69E-05 |
| Ru-106  | 3.68E-05 | No Data  | 4.57E-06 | No Data  | 4.97E-05 | 3.87E-03 | 1.16E-04 |
| Rh-105  | No Data  | No Data  | No Data  | No Data  | No Data  | No Data  | No Data  |
| Ag-110m | 4.56E-06 | 3.08E-06 | 2.47E-06 | No Data  | 5.74E-06 | 1.48E-03 | 2.71E-05 |
| Sb-124  | No Data  | No Data  | No Data  | No Data  | No Data  | No Data  | No Data  |
| Sb-125  | No Data  | No Data  | No Data  | No Data  | No Data  | No Data  | No Data  |
| Te-125m | 1.82E-06 | 6.29E-07 | 2.47E-07 | 5.20E-07 | No Data  | 1.29E-04 | 9.13E-06 |
| Te-127m | 6.72E-06 | 2.31E-06 | 8.16E-07 | 1.64E-06 | 1.72E-05 | 4.00E-04 | 1.93E-05 |
| Te-127  | 7.49E-10 | 2.57E-10 | 1.65E-10 | 5.30E-10 | 1.91E-09 | 2.71E-06 | 1.52E-05 |
| Te-129m | 5.19E-06 | 1.85E-06 | 8.22E-07 | 1.71E-06 | 1.36E-05 | 4.76E-04 | 4.91E-05 |
| Te-129  | 2.64E-11 | 9.45E-12 | 6.44E-12 | 1.93E-11 | 6.94E-11 | 7.93E-07 | 6.89E-06 |
| Te-131m | 3.63E-08 | 1.60E-08 | 1.37E-08 | 2.64E-08 | 1.08E-07 | 5.56E-05 | 8.32E-05 |
| Te-131  | 5.87E-12 | 2.28E-12 | 1.78E-12 | 4.59E-12 | 1.59E-11 | 5.55E-07 | 3.60E-07 |

Table 9-8 (contd). Inhalation Dose Factors for the Child Age Group

| Nuclide | Bone     | Liver    | T.Body   | Thyroid  | Kidney   | Lung     | GI-LLI   |
|---------|----------|----------|----------|----------|----------|----------|----------|
| Te-132  | 1.30E-07 | 7.36E-08 | 7.12E-08 | 8.58E-08 | 4.79E-07 | 1.02E-04 | 3.72E-05 |
| I-130   | 2.21E-06 | 4.43E-06 | 2.28E-06 | 4.99E-04 | 6.61E-06 | No Data  | 1.38E-06 |
| I-131   | 1.30E-05 | 1.30E-05 | 7.37E-06 | 4.39E-03 | 2.13E-05 | No Data  | 7.68E-07 |
| I-132   | 5.72E-07 | 1.10E-06 | 5.07E-07 | 5.23E-05 | 1.69E-06 | No Data  | 8.65E-07 |
| I-133   | 4.48E-06 | 5.49E-06 | 2.08E-06 | 1.04E-03 | 9.13E-06 | No Data  | 1.48E-06 |
| I-134   | 3.17E-07 | 5.84E-07 | 2.69E-07 | 1.37E-05 | 8.92E-07 | No Data  | 2.58E-07 |
| I-135   | 1.33E-06 | 2.36E-06 | 1.12E-06 | 2.14E-04 | 3.62E-06 | No Data  | 1.20E-06 |
| Cs-134  | 1.76E-04 | 2.74E-04 | 6.07E-05 | No Data  | 8.93E-05 | 3.27E-05 | 1.04E-06 |
| Cs-136  | 1.76E-05 | 4.62E-05 | 3.14E-05 | No Data  | 2.58E-05 | 3.93E-06 | 1.13E-06 |
| Cs-137  | 2.45E-04 | 2.23E-04 | 3.47E-05 | No Data  | 7.63E-05 | 2.81E-05 | 9.78E-07 |
| Cs-138  | 1.71E-07 | 2.27E-07 | 1.50E-07 | No Data  | 1.68E-07 | 1.84E-08 | 7.29E-08 |
| Ba-139  | 4.98E-10 | 2.66E-13 | 1.45E-11 | No Data  | 2.33E-13 | 1.56E-06 | 1.56E-05 |
| Ba-140  | 2.00E-05 | 1.75E-08 | 1.17E-06 | No Data  | 5.71E-09 | 4.71E-04 | 2.75E-05 |
| Ba-141  | 5.29E-11 | 2.95E-14 | 1.72E-12 | No Data  | 2.56E-14 | 7.89E-07 | 7.44E-08 |
| Ba-142  | 1.35E-11 | 9.73E-15 | 7.54E-13 | No Data  | 7.87E-15 | 4.44E-07 | 7.41E-10 |
| La-140  | 1.74E-07 | 6.08E-08 | 2.04E-08 | No Data  | No Data  | 4.94E-05 | 6.10E-05 |
| La-142  | 3.50E-10 | 1.11E-10 | 3.49E-11 | No Data  | No Data  | 2.35E-06 | 2.05E-05 |
| Ce-141  | 1.06E-05 | 5.28E-06 | 7.83E-07 | No Data  | 2.31E-06 | 1.47E-04 | 1.53E-05 |
| Ce-143  | 9.89E-08 | 5.37E-08 | 7.77E-09 | No Data  | 2.26E-08 | 3.12E-05 | 3.44E-05 |
| Ce-144  | 1.83E-03 | 5.72E-04 | 9.77E-05 | No Data  | 3.17E-04 | 3.23E-03 | 1.05E-04 |
| Pr-143  | 4.99E-06 | 1.50E-06 | 2.47E-07 | No Data  | 8.11E-07 | 1.17E-04 | 2.63E-05 |
| Pr-144  | 1.61E-11 | 4.99E-12 | 8.10E-13 | No Data  | 2.64E-12 | 4.23E-07 | 5.32E-08 |
| Nd-147  | 2.92E-06 | 2.36E-06 | 1.84E-07 | No Data  | 1.30E-06 | 8.87E-05 | 2.22E-05 |
| W-187   | 4.41E-09 | 2.61E-09 | 1.17E-09 | No Data  | No Data  | 1.11E-05 | 2.46E-05 |
| Np-239  | 1.26E-07 | 9.04E-09 | 6.35E-09 | No Data  | 2.63E-08 | 1.57E-05 | 1.73E-05 |

Table 9-9. Inhalation Dose Factors for the Teenager Age Group

| Nuclide | Bone     | Liver    | T.Body   | Thyroid  | Kidney   | Lung     | GI-LLI   |
|---------|----------|----------|----------|----------|----------|----------|----------|
| H-3     | No Data  | 1.59E-07 | 1.59E-07 | 1.59E-07 | 1.59E-07 | 1.59E-07 | 1.59E-07 |
| C-14    | 3.25E-06 | 6.09E-07 | 6.09E-07 | 6.09E-07 | 6.09E-07 | 6.09E-07 | 6.09E-07 |
| Na-24   | 1.72E-06 | 1.72E-06 | 1.72E-06 | 1.72E-06 | 1.72E-06 | 1.72E-06 | 1.72E-06 |
| P-32    | 2.36E-04 | 1.37E-08 | 8.95E-06 | No Data  | No Data  | No Data  | 1.16E-05 |
| Cr-51   | No Data  | No Data  | 1.69E-08 | 9.37E-09 | 3.84E-09 | 2.62E-06 | 3.75E-07 |
| Mn-54   | No Data  | 6.39E-06 | 1.05E-06 | No Data  | 1.59E-06 | 2.48E-04 | 8.35E-06 |
| Mn-56   | No Data  | 2.12E-10 | 3.15E-11 | No Data  | 2.24E-10 | 1.90E-06 | 7.18E-06 |
| Fe-55   | 4.18E-06 | 2.98E-06 | 6.93E-07 | No Data  | No Data  | 1.55E-05 | 7.99E-07 |
| Fe-59   | 1.99E-06 | 4.62E-06 | 1.79E-06 | No Data  | No Data  | 1.91E-04 | 2.23E-05 |
| Co-58   | No Data  | 2.59E-07 | 3.47E-07 | No Data  | No Data  | 1.68E-04 | 1.19E-05 |
| Co-60   | No Data  | 1.89E-06 | 2.48E-06 | No Data  | No Data  | 1.09E-03 | 3.24E-05 |
| Ni-63   | 7.25E-05 | 5.43E-06 | 2.47E-06 | No Data  | No Data  | 3.84E-05 | 1.77E-06 |
| Ni-65   | 2.73E-10 | 3.66E-11 | 1.59E-11 | No Data  | No Data  | 1.17E-06 | 4.59E-06 |
| Cu-64   | No Data  | 2.54E-10 | 1.06E-10 | No Data  | 8.01E-10 | 1.39E-06 | 7.68E-06 |
| Zn-65   | 4.82E-06 | 1.67E-05 | 7.80E-06 | No Data  | 1.08E-05 | 1.55E-04 | 5.83E-06 |
| Zn-69   | 6.04E-12 | 1.15E-11 | 8.07E-13 | No Data  | 7.53E-12 | 1.98E-07 | 3.56E-08 |
| Br-83   | No Data  | No Data  | 4.30E-08 | No Data  | No Data  | No Data  | No Data  |
| Br-84   | No Data  | No Data  | 5.41E-08 | No Data  | No Data  | No Data  | No Data  |
| Br-85   | No Data  | No Data  | 2.29E-09 | No Data  | No Data  | No Data  | No Data  |
| Rb-86   | No Data  | 2.38E-05 | 1.05E-05 | No Data  | No Data  | No Data  | 2.21E-06 |
| Rb-88   | No Data  | 6.82E-08 | 3.40E-08 | No Data  | No Data  | No Data  | 3.65E-15 |
| Rb-89   | No Data  | 4.40E-08 | 2.91E-08 | No Data  | No Data  | No Data  | 4.22E-17 |
| Sr-89   | 5.43E-05 | No Data  | 1.56E-06 | No Data  | No Data  | 3.02E-04 | 4.64E-05 |
| Sr-90   | 1.35E-02 | No Data  | 8.35E-04 | No Data  | No Data  | 2.06E-03 | 9.56E-05 |
| Sr-91   | 1.10E-08 | No Data  | 4.39E-10 | No Data  | No Data  | 7.59E-06 | 3.24E-05 |

All values are in (mrem/pCi inhaled). They are obtained from Reference 3 (Table E-8). Neither Reference 2 nor Reference 3 contains data for Rh-105, Sb-124, or Sb-125.

Table 9-9 (contd). Inhalation Dose Factors for the Teenager Age Group

| Nuclide | Bone     | Liver    | T.Body   | Thyroid  | Kidney   | Lung     | GI-LLI   |
|---------|----------|----------|----------|----------|----------|----------|----------|
| Sr-92   | 1.19E-09 | No Data  | 5.08E-11 | No Data  | No Data  | 3.43E-06 | 1.49E-05 |
| Y-90    | 3.73E-07 | No Data  | 1.00E-08 | No Data  | No Data  | 3.66E-05 | 6.99E-05 |
| Y-91m   | 4.63E-11 | No Data  | 1.77E-12 | No Data  | No Data  | 4.00E-07 | 3.77E-09 |
| Y-91    | 8.26E-05 | No Data  | 2.21E-06 | No Data  | No Data  | 3.67E-04 | 5.11E-05 |
| Y-92    | 1.84E-09 | No Data  | 5.36E-11 | No Data  | No Data  | 3.35E-06 | 2.06E-05 |
| Y-93    | 1.69E-08 | No Data  | 4.65E-10 | No Data  | No Data  | 1.04E-05 | 7.24E-05 |
| Zr-95   | 1.82E-05 | 5.73E-06 | 3.94E-06 | No Data  | 8.42E-06 | 3.36E-04 | 1.86E-05 |
| Zr-97   | 1.72E-08 | 3.40E-09 | 1.57E-09 | No Data  | 5.15E-09 | 1.62E-05 | 7.88E-05 |
| Nb-95   | 2.32E-06 | 1.29E-06 | 7.08E-07 | No Data  | 1.25E-06 | 9.39E-05 | 1.21E-05 |
| Mo-99   | No Data  | 2.11E-08 | 4.03E-09 | No Data  | 5.14E-08 | 1.92E-05 | 3.36E-05 |
| Tc-99m  | 1.73E-13 | 4.83E-13 | 6.24E-12 | No Data  | 7.20E-12 | 1.44E-07 | 7.66E-07 |
| Tc-101  | 7.40E-15 | 1.05E-14 | 1.03E-13 | No Data  | 1.90E-13 | 8.34E-08 | 1.09E-16 |
| Ru-103  | 2.63E-07 | No Data  | 1.12E-07 | No Data  | 9.29E-07 | 9.79E-05 | 1.36E-05 |
| Ru-105  | 1.40E-10 | No Data  | 5.42E-11 | No Data  | 1.76E-10 | 2.27E-06 | 1.13E-05 |
| Ru-106  | 1.23E-05 | No Data  | 1.55E-06 | No Data  | 2.38E-05 | 2.01E-03 | 1.20E-04 |
| Rh-105  | No Data  | No Data  | No Data  | No Data  | No Data  | No Data  | No Data  |
| Ag-110m | 1.73E-06 | 1.64E-06 | 9.99E-07 | No Data  | 3.13E-06 | 8.44E-04 | 3.41E-05 |
| Sb-124  | No Data  | No Data  | No Data  | No Data  | No Data  | No Data  | No Data  |
| Sb-125  | No Data  | No Data  | No Data  | No Data  | No Data  | No Data  | No Data  |
| Te-125m | 6.10E-07 | 2.80E-07 | 8.34E-08 | 1.75E-07 | No Data  | 6.70E-05 | 9.38E-06 |
| Te-127m | 2.25E-06 | 1.02E-06 | 2.73E-07 | 5.48E-07 | 8.17E-06 | 2.07E-04 | 1.99E-05 |
| Te-127  | 2.51E-10 | 1.14E-10 | 5.52E-11 | 1.77E-10 | 9.10E-10 | 1.40E-06 | 1.01E-05 |
| Te-129m | 1.74E-06 | 8.23E-07 | 2.81E-07 | 5.72E-07 | 6.49E-06 | 2.47E-04 | 5.06E-05 |
| Te-129  | 8.87E-12 | 4.22E-12 | 2.20E-12 | 6.48E-12 | 3.32E-11 | 4.12E-07 | 2.02E-07 |
| Te-131m | 1.23E-08 | 7.51E-09 | 5.03E-09 | 9.06E-09 | 5.49E-08 | 2.97E-05 | 7.76E-05 |
| Te-131  | 1.97E-12 | 1.04E-12 | 6.30E-13 | 1.55E-12 | 7.72E-12 | 2.92E-07 | 1.89E-09 |

Table 9-9 (contd). Inhalation Dose Factors for the Teenager Age Group

| Nuclide | Bone     | Liver    | T.Body   | Thyroid  | Kidney   | Lung     | GI-LLI   |
|---------|----------|----------|----------|----------|----------|----------|----------|
| Te-132  | 4.50E-08 | 3.63E-08 | 2.74E-08 | 3.07E-08 | 2.44E-07 | 5.61E-05 | 5.79E-05 |
| I-130   | 7.80E-07 | 2.24E-06 | 8.96E-07 | 1.86E-04 | 3.44E-06 | No Data  | 1.14E-06 |
| I-131   | 4.43E-06 | 6.14E-06 | 3.30E-06 | 1.83E-03 | 1.05E-05 | No Data  | 8.11E-07 |
| I-132   | 1.99E-07 | 5.47E-07 | 1.97E-07 | 1.89E-05 | 8.65E-07 | No Data  | 1.59E-07 |
| I-133   | 1.52E-06 | 2.56E-06 | 7.78E-07 | 3.65E-04 | 4.49E-06 | No Data  | 1.29E-06 |
| I-134   | 1.11E-07 | 2.90E-07 | 1.05E-07 | 4.94E-06 | 4.58E-07 | No Data  | 2.55E-09 |
| I-135   | 4.62E-07 | 1.18E-06 | 4.36E-07 | 7.76E-05 | 1.86E-06 | No Data  | 8.69E-07 |
| Cs-134  | 6.28E-05 | 1.41E-04 | 6.86E-05 | No Data  | 4.69E-05 | 1.83E-05 | 1.22E-06 |
| Cs-136  | 6.44E-06 | 2.42E-05 | 1.71E-05 | No Data  | 1.38E-05 | 2.22E-06 | 1.36E-06 |
| Cs-137  | 8.38E-05 | 1.06E-04 | 3.89E-05 | No Data  | 3.80E-05 | 1.51E-05 | 1.06E-06 |
| Cs-138  | 5.82E-08 | 1.07E-07 | 5.58E-08 | No Data  | 8.28E-08 | 9.84E-09 | 3.38E-11 |
| Ba-139  | 1.67E-10 | 1.18E-13 | 4.87E-12 | No Data  | 1.11E-13 | 8.08E-07 | 8.06E-07 |
| Ba-140  | 6.84E-06 | 8.38E-09 | 4.40E-07 | No Data  | 2.85E-09 | 2.54E-04 | 2.86E-05 |
| Ba-141  | 1.78E-11 | 1.32E-14 | 5.93E-13 | No Data  | 1.23E-14 | 4.11E-07 | 9.33E-14 |
| Ba-142  | 4.62E-12 | 4.63E-15 | 2.84E-13 | No Data  | 3.92E-15 | 2.39E-07 | 5.99E-20 |
| La-140  | 5.99E-08 | 2.95E-08 | 7.82E-09 | No Data  | No Data  | 2.68E-05 | 6.09E-05 |
| La-142  | 1.20E-10 | 5.31E-11 | 1.32E-11 | No Data  | No Data  | 1.27E-06 | 1.50E-06 |
| Ce-141  | 3.55E-06 | 2.37E-06 | 2.71E-07 | No Data  | 1.11E-06 | 7.67E-05 | 1.58E-05 |
| Ce-143  | 3.32E-08 | 2.42E-08 | 2.70E-09 | No Data  | 1.08E-08 | 1.63E-05 | 3.19E-05 |
| Ce-144  | 6.11E-04 | 2.53E-04 | 3.28E-05 | No Data  | 1.51E-04 | 1.67E-03 | 1.08E-04 |
| Pr-143  | 1.67E-06 | 6.64E-07 | 8.28E-08 | No Data  | 3.86E-07 | 6.04E-05 | 2.67E-05 |
| Pr-144  | 5.37E-12 | 2.20E-12 | 2.72E-13 | No Data  | 1.26E-12 | 2.19E-07 | 2.94E-14 |
| Nd-147  | 9.83E-07 | 1.07E-06 | 6.41E-08 | No Data  | 6.28E-07 | 4.65E-05 | 2.28E-05 |
| W-187   | 1.50E-09 | 1.22E-09 | 4.29E-10 | No Data  | No Data  | 5.92E-06 | 2.21E-05 |
| Np-239  | 4.23E-08 | 3.99E-09 | 2.21E-09 | No Data  | 1.25E-08 | 8.11E-06 | 1.65E-05 |

Table 9-10. Inhalation Dose Factors for the Adult Age Group

| Nuclide | Bone     | Liver    | T. Body  | Thyroid  | Kidney   | Lung     | GI-LLI   |
|---------|----------|----------|----------|----------|----------|----------|----------|
| H-3     | No Data  | 1.58E-07 | 1.58E-07 | 1.58E-07 | 1.58E-07 | 1.58E-07 | 1.58E-07 |
| C-14    | 2.27E-06 | 4.26E-07 | 4.26E-07 | 4.26E-07 | 4.26E-07 | 4.26E-07 | 4.26E-07 |
| Na-24   | 1.28E-06 | 1.28E-06 | 1.28E-06 | 1.28E-06 | 1.28E-06 | 1.28E-06 | 1.28E-06 |
| P-32    | 1.65E-04 | 9.64E-06 | 6.26E-06 | No Data  | No Data  | No Data  | 1.08E-05 |
| Cr-51   | No Data  | No Data  | 1.25E-08 | 7.44E-09 | 2.85E-09 | 1.80E-06 | 4.15E-07 |
| Mn-54   | No Data  | 4.95E-06 | 7.87E-07 | No Data  | 1.23E-06 | 1.75E-04 | 9.67E-06 |
| Mn-56   | No Data  | 1.55E-10 | 2.29E-11 | No Data  | 1.63E-10 | 1.18E-06 | 2.53E-06 |
| Fe-55   | 3.07E-06 | 2.12E-06 | 4.93E-07 | No Data  | No Data  | 9.01E-06 | 7.54E-07 |
| Fe-59   | 1.47E-06 | 3.47E-06 | 1.32E-06 | No Data  | No Data  | 1.27E-04 | 2.35E-05 |
| Co-58   | No Data  | 1.98E-07 | 2.59E-07 | No Data  | No Data  | 1.16E-04 | 1.33E-05 |
| Co-60   | No Data  | 1.44E-06 | 1.85E-06 | No Data  | No Data  | 7.46E-04 | 3.56E-05 |
| Ni-63   | 5.40E-05 | 3.93E-06 | 1.81E-06 | No Data  | No Data  | 2.23E-05 | 1.67E-06 |
| Ni-65   | 1.92E-10 | 2.62E-11 | 1.14E-11 | No Data  | No Data  | 7.00E-07 | 1.54E-06 |
| Cu-64   | No Data  | 1.83E-10 | 7.69E-11 | No Data  | 5.78E-10 | 8.48E-07 | 6.12E-06 |
| Zn-65   | 4.05E-06 | 1.29E-05 | 5.82E-06 | No Data  | 8.62E-06 | 1.08E-04 | 6.68E-06 |
| Zn-69   | 4.23E-12 | 8.14E-12 | 5.65E-13 | No Data  | 5.27E-12 | 1.15E-07 | 2.04E-09 |
| Br-83   | No Data  | No Data  | 3.01E-08 | No Data  | No Data  | No Data  | 2.90E-08 |
| Br-84   | No Data  | No Data  | 3.91E-08 | No Data  | No Data  | No Data  | 2.05E-13 |
| Br-85   | No Data  | No Data  | 1.60E-09 | No Data  | No Data  | No Data  | No Data  |
| Rb-86   | No Data  | 1.69E-05 | 7.37E-06 | No Data  | No Data  | No Data  | 2.08E-06 |
| Rb-88   | No Data  | 4.84E-08 | 2.41E-08 | No Data  | No Data  | No Data  | 4.18E-19 |
| Rb-89   | No Data  | 3.20E-08 | 2.12E-08 | No Data  | No Data  | No Data  | 1.16E-21 |
| Sr-89   | 3.80E-05 | No Data  | 1.09E-06 | No Data  | No Data  | 1.75E-04 | 4.37E-05 |
| Sr-90   | 1.24E-02 | No Data  | 7.62E-04 | No Data  | No Data  | 1.20E-03 | 9.02E-05 |
| Sr-91   | 7.74E-09 | No Data  | 3.13E-10 | No Data  | No Data  | 4.56E-06 | 2.39E-05 |

All values are in (mrem/pCi inhaled). They are obtained from Reference 3 (Table E-7), except as follows: Reference 2 (Table C-1) for Rh-105, Sb-124, and Sb-125.

Table 9-10 (contd). Inhalation Dose Factors for the Adult Age Group

| Nuclide | Bone     | Liver    | T.Body   | Thyroid  | Kidney   | Lung     | GI-LLI   |
|---------|----------|----------|----------|----------|----------|----------|----------|
| Sr-92   | 8.43E-10 | No Data  | 3.64E-11 | No Data  | No Data  | 2.06E-06 | 5.38E-06 |
| Y-90    | 2.61E-07 | No Data  | 7.01E-09 | No Data  | No Data  | 2.12E-05 | 6.32E-05 |
| Y-91m   | 3.26E-11 | No Data  | 1.27E-12 | No Data  | No Data  | 2.40E-07 | 1.66E-10 |
| Y-91    | 5.78E-05 | No Data  | 1.55E-06 | No Data  | No Data  | 2.13E-04 | 4.81E-05 |
| Y-92    | 1.29E-09 | No Data  | 3.77E-11 | No Data  | No Data  | 1.96E-06 | 9.19E-06 |
| Y-93    | 1.18E-08 | No Data  | 3.26E-10 | No Data  | No Data  | 6.06E-06 | 5.27E-05 |
| Zr-95   | 1.34E-05 | 4.30E-06 | 2.91E-06 | No Data  | 6.77E-06 | 2.21E-04 | 1.88E-05 |
| Zr-97   | 1.21E-08 | 2.45E-09 | 1.13E-09 | No Data  | 3.71E-09 | 9.84E-06 | 6.54E-05 |
| Nb-95   | 1.76E-06 | 9.77E-07 | 5.26E-07 | No Data  | 9.67E-07 | 6.31E-05 | 1.30E-05 |
| Mo-99   | No Data  | 1.51E-08 | 2.87E-09 | No Data  | 3.64E-08 | 1.14E-05 | 3.10E-05 |
| Tc-99m  | 1.29E-13 | 3.64E-13 | 4.63E-12 | No Data  | 5.52E-12 | 9.55E-08 | 5.20E-07 |
| Tc-101  | 5.22E-15 | 7.52E-15 | 7.38E-14 | No Data  | 1.35E-13 | 4.99E-08 | 1.36E-21 |
| Ru-103  | 1.91E-07 | No Data  | 8.23E-08 | No Data  | 7.29E-07 | 6.31E-05 | 1.38E-05 |
| Ru-105  | 9.88E-11 | No Data  | 3.89E-11 | No Data  | 1.27E-10 | 1.37E-06 | 6.02E-06 |
| Ru-106  | 8.64E-06 | No Data  | 1.09E-06 | No Data  | 1.67E-05 | 1.17E-03 | 1.14E-04 |
| Rh-105  | 9.24E-10 | 6.73E-10 | 4.43E-10 | No Data  | 2.86E-09 | 2.41E-06 | 1.09E-05 |
| Ag-110m | 1.35E-06 | 1.25E-06 | 7.43E-07 | No Data  | 2.46E-06 | 5.79E-04 | 3.78E-05 |
| Sb-124  | 3.90E-06 | 7.36E-08 | 1.55E-06 | 9.44E-09 | No Data  | 3.10E-04 | 5.08E-05 |
| Sb-125  | 8.26E-06 | 8.91E-08 | 1.66E-06 | 7.34E-09 | No Data  | 2.75E-04 | 1.26E-05 |
| Te-125m | 4.27E-07 | 1.98E-07 | 5.84E-08 | 1.31E-07 | 1.55E-06 | 3.92E-05 | 8.83E-06 |
| Te-127m | 1.58E-06 | 7.21E-07 | 1.96E-07 | 4.11E-07 | 5.72E-06 | 1.20E-04 | 1.87E-05 |
| Te-127  | 1.75E-10 | 8.03E-11 | 3.87E-11 | 1.32E-10 | 6.37E-10 | 8.14E-07 | 7.17E-06 |
| Te-129m | 1.22E-06 | 5.84E-07 | 1.98E-07 | 4.30E-07 | 4.57E-06 | 1.45E-04 | 4.79E-05 |
| Te-129  | 6.22E-12 | 2.99E-12 | 1.55E-12 | 4.87E-12 | 2.34E-11 | 2.42E-07 | 1.96E-08 |
| Te-131m | 8.74E-09 | 5.45E-09 | 3.63E-09 | 6.88E-09 | 3.86E-08 | 1.82E-05 | 6.95E-05 |
| Te-131  | 1.39E-12 | 7.44E-13 | 4.49E-13 | 1.17E-12 | 5.46E-12 | 1.74E-07 | 2.30E-09 |

Table 9-10 (contd). Inhalation Dose Factors for the Adult Age Group

| Nuclide | Bone     | Liver    | T.Body   | Thyroid  | Kidney   | Lung     | GI-LLI   |
|---------|----------|----------|----------|----------|----------|----------|----------|
| Te-132  | 3.25E-08 | 2.69E-08 | 2.02E-08 | 2.37E-08 | 1.82E-07 | 3.60E-05 | 6.37E-05 |
| I-130   | 5.72E-07 | 1.68E-06 | 6.60E-07 | 1.42E-04 | 2.61E-06 | No Data  | 9.61E-07 |
| I-131   | 3.15E-06 | 4.47E-06 | 2.56E-06 | 1.49E-03 | 7.66E-06 | No Data  | 7.85E-07 |
| I-132   | 1.45E-07 | 4.07E-07 | 1.45E-07 | 1.43E-05 | 6.48E-07 | No Data  | 5.08E-08 |
| I-133   | 1.08E-06 | 1.85E-06 | 5.65E-07 | 2.69E-04 | 3.23E-06 | No Data  | 1.11E-06 |
| I-134   | 8.05E-08 | 2.16E-07 | 7.69E-08 | 3.73E-06 | 3.44E-07 | No Data  | 1.26E-10 |
| I-135   | 3.35E-07 | 8.73E-07 | 3.21E-07 | 5.60E-05 | 1.39E-06 | No Data  | 6.56E-07 |
| Cs-134  | 4.66E-05 | 1.06E-04 | 9.10E-05 | No Data  | 3.59E-05 | 1.22E-05 | 1.30E-06 |
| Cs-136  | 4.88E-06 | 1.83E-05 | 1.38E-05 | No Data  | 1.07E-05 | 1.50E-06 | 1.46E-06 |
| Cs-137  | 5.98E-05 | 7.76E-05 | 5.35E-05 | No Data  | 2.78E-05 | 9.40E-06 | 1.05E-06 |
| Cs-138  | 4.14E-08 | 7.76E-08 | 4.05E-08 | No Data  | 6.00E-08 | 6.07E-09 | 2.33E-13 |
| Ba-139  | 1.17E-10 | 8.32E-14 | 3.42E-12 | No Data  | 7.78E-14 | 4.70E-07 | 1.12E-07 |
| Ba-140  | 4.88E-06 | 6.13E-09 | 3.21E-07 | No Data  | 2.09E-09 | 1.59E-04 | 2.73E-05 |
| Ba-141  | 1.25E-11 | 9.41E-15 | 4.20E-13 | No Data  | 8.75E-15 | 2.42E-07 | 1.45E-17 |
| Ba-142  | 3.29E-12 | 3.38E-15 | 2.07E-13 | No Data  | 2.86E-15 | 1.49E-07 | 1.96E-26 |
| La-140  | 4.30E-08 | 2.17E-08 | 5.73E-09 | No Data  | No Data  | 1.70E-05 | 5.73E-05 |
| La-142  | 8.54E-11 | 3.88E-11 | 9.65E-12 | No Data  | No Data  | 7.91E-07 | 2.64E-07 |
| Ce-141  | 2.49E-06 | 1.69E-06 | 1.91E-07 | No Data  | 7.83E-07 | 4.52E-05 | 1.50E-05 |
| Ce-143  | 2.33E-08 | 1.72E-08 | 1.91E-09 | No Data  | 7.60E-09 | 9.97E-06 | 2.83E-05 |
| Ce-144  | 4.29E-04 | 1.79E-04 | 2.30E-05 | No Data  | 1.06E-04 | 9.72E-04 | 1.02E-04 |
| Pr-143  | 1.17E-06 | 4.69E-07 | 5.80E-08 | No Data  | 2.70E-07 | 3.51E-05 | 2.50E-05 |
| Pr-144  | 3.76E-12 | 1.56E-12 | 1.91E-13 | No Data  | 8.81E-13 | 1.27E-07 | 2.69E-18 |
| Nd-147  | 6.59E-07 | 7.62E-07 | 4.56E-08 | No Data  | 4.45E-07 | 2.76E-05 | 2.16E-05 |
| W-187   | 1.06E-09 | 8.85E-10 | 3.10E-10 | No Data  | No Data  | 3.63E-06 | 1.94E-05 |
| Np-239  | 2.87E-08 | 2.82E-09 | 1.55E-09 | No Data  | 8.75E-09 | 4.70E-06 | 1.49E-05 |

Table 9-11. Ingestion Dose Factors for the Infant Age Group

| Nuclide | Bone     | Liver    | T.Body   | Thyroid  | Kidney   | Lung     | GI-LLI   |
|---------|----------|----------|----------|----------|----------|----------|----------|
| H-3     | No Data  | 3.08E-07 | 3.08E-07 | 3.08E-07 | 3.08E-07 | 3.08E-07 | 3.08E-07 |
| C-14    | 2.37E-05 | 5.06E-06 | 5.06E-06 | 5.06E-06 | 5.06E-06 | 5.06E-06 | 5.06E-06 |
| Na-24   | 1.01E-05 | 1.01E-05 | 1.01E-05 | 1.01E-05 | 1.01E-05 | 1.01E-05 | 1.01E-05 |
| P-32    | 1.70E-03 | 1.00E-04 | 6.59E-05 | No Data  | No Data  | No Data  | 2.30E-05 |
| Cr-51   | No Data  | No Data  | 1.41E-08 | 9.20E-09 | 2.01E-09 | 1.79E-08 | 4.11E-07 |
| Mn-54   | No Data  | 1.99E-05 | 4.51E-06 | No Data  | 4.41E-06 | No Data  | 7.31E-06 |
| Mn-56   | No Data  | 8.18E-07 | 1.41E-07 | No Data  | 7.03E-07 | No Data  | 7.43E-05 |
| Fe-55   | 1.39E-05 | 8.98E-06 | 2.40E-06 | No Data  | No Data  | 4.39E-06 | 1.14E-06 |
| Fe-59   | 3.08E-05 | 5.38E-05 | 2.12E-05 | No Data  | No Data  | 1.59E-05 | 2.57E-05 |
| Co-58   | No Data  | 3.60E-06 | 8.98E-06 | No Data  | No Data  | No Data  | 8.97E-06 |
| Co-60   | No Data  | 1.08E-05 | 2.55E-05 | No Data  | No Data  | No Data  | 2.57E-05 |
| Ni-63   | 6.34E-04 | 3.92E-05 | 2.20E-05 | No Data  | No Data  | No Data  | 1.95E-06 |
| Ni-65   | 4.70E-06 | 5.32E-07 | 2.42E-07 | No Data  | No Data  | No Data  | 4.05E-05 |
| Cu-64   | No Data  | 6.09E-07 | 2.82E-07 | No Data  | 1.03E-06 | No Data  | 1.25E-05 |
| Zn-65   | 1.84E-05 | 6.31E-05 | 2.91E-05 | No Data  | 3.06E-05 | No Data  | 5.33E-05 |
| Zn-69   | 9.33E-08 | 1.68E-07 | 1.25E-08 | No Data  | 6.98E-08 | No Data  | 1.37E-05 |
| Br-83   | No Data  | No Data  | 3.63E-07 | No Data  | No Data  | No Data  | No Data  |
| Br-84   | No Data  | No Data  | 3.82E-07 | No Data  | No Data  | No Data  | No Data  |
| Br-85   | No Data  | No Data  | 1.94E-08 | No Data  | No Data  | No Data  | No Data  |
| Rb-86   | No Data  | 1.70E-04 | 8.40E-05 | No Data  | No Data  | No Data  | 4.35E-06 |
| Rb-88   | No Data  | 4.98E-07 | 2.73E-07 | No Data  | No Data  | No Data  | 4.85E-07 |
| Rb-89   | No Data  | 2.86E-07 | 1.97E-07 | No Data  | No Data  | No Data  | 9.74E-08 |
| Sr-89   | 2.51E-03 | No Data  | 7.20E-05 | No Data  | No Data  | No Data  | 5.16E-05 |
| Sr-90   | 1.85E-02 | No Data  | 4.71E-03 | No Data  | No Data  | No Data  | 2.31E-04 |
| Sr-91   | 5.00E-05 | No Data  | 1.81E-06 | No Data  | No Data  | No Data  | 5.92E-05 |

All values are in (mrem/pCi ingested). They are obtained from Reference 3 (Table E-14). Neither Reference 2 nor Reference 3 contains data for Rh-105, Sb-124, or Sb-125.

Table 9-11 (contd). Ingestion Dose Factors for the Infant Age Group

| Nuclide | Bone     | Liver    | T.Body   | Thyroid  | Kidney   | Lung     | GI-LLI   |
|---------|----------|----------|----------|----------|----------|----------|----------|
| Sr-92   | 1.92E-05 | No Data  | 7.13E-07 | No Data  | No Data  | No Data  | 2.07E-04 |
| Y-90    | 8.69E-08 | No Data  | 2.33E-09 | No Data  | No Data  | No Data  | 1.20E-04 |
| Y-91m   | 8.10E-10 | No Data  | 2.76E-11 | No Data  | No Data  | No Data  | 2.70E-06 |
| Y-91    | 1.13E-06 | No Data  | 3.01E-08 | No Data  | No Data  | No Data  | 8.10E-05 |
| Y-92    | 7.65E-09 | No Data  | 2.15E-10 | No Data  | No Data  | No Data  | 1.46E-04 |
| Y-93    | 2.43E-08 | No Data  | 6.62E-10 | No Data  | No Data  | No Data  | 1.92E-04 |
| Zr-95   | 2.06E-07 | 5.02E-08 | 3.56E-08 | No Data  | 5.41E-08 | No Data  | 2.50E-05 |
| Zr-97   | 1.48E-08 | 2.54E-09 | 1.16E-09 | No Data  | 2.56E-09 | No Data  | 1.62E-04 |
| Nb-95   | 4.20E-08 | 1.73E-08 | 1.00E-08 | No Data  | 1.24E-08 | No Data  | 1.46E-05 |
| Mo-99   | No Data  | 3.40E-05 | 6.63E-06 | No Data  | 5.08E-05 | No Data  | 1.12E-05 |
| Tc-99m  | 1.92E-09 | 3.96E-09 | 5.10E-08 | No Data  | 4.26E-08 | 2.07E-09 | 1.15E-06 |
| Tc-101  | 2.27E-09 | 2.86E-09 | 2.83E-08 | No Data  | 3.40E-08 | 1.56E-09 | 4.86E-07 |
| Ru-103  | 1.48E-06 | No Data  | 4.95E-07 | No Data  | 3.08E-06 | No Data  | 1.80E-05 |
| Ru-105  | 1.36E-07 | No Data  | 4.58E-08 | No Data  | 1.00E-06 | No Data  | 5.41E-05 |
| Ru-106  | 2.41E-05 | No Data  | 3.01E-06 | No Data  | 2.85E-05 | No Data  | 1.83E-04 |
| Rh-105  | No Data  | No Data  | No Data  | No Data  | No Data  | No Data  | No Data  |
| Ag-110m | 9.96E-07 | 7.27E-07 | 4.81E-07 | No Data  | 1.04E-06 | No Data  | 3.77E-05 |
| Sb-124  | No Data  | No Data  | No Data  | No Data  | No Data  | No Data  | No Data  |
| Sb-125  | No Data  | No Data  | No Data  | No Data  | No Data  | No Data  | No Data  |
| Te-125m | 2.33E-05 | 7.79E-06 | 3.15E-06 | 7.84E-06 | No Data  | No Data  | 1.11E-05 |
| Te-127m | 5.85E-05 | 1.94E-05 | 7.08E-06 | 1.69E-05 | 1.44E-04 | No Data  | 2.36E-05 |
| Te-127  | 1.00E-06 | 3.35E-07 | 2.15E-07 | 8.14E-07 | 2.44E-06 | No Data  | 2.10E-05 |
| Te-129m | 1.00E-04 | 3.43E-05 | 1.54E-05 | 3.84E-05 | 2.50E-04 | No Data  | 5.97E-05 |
| Te-129  | 2.84E-07 | 9.79E-08 | 6.63E-08 | 2.38E-07 | 7.07E-07 | No Data  | 2.27E-05 |
| Te-131m | 1.52E-05 | 6.12E-06 | 5.05E-06 | 1.24E-05 | 4.21E-05 | No Data  | 1.03E-04 |
| Te-131  | 1.76E-07 | 6.50E-08 | 4.94E-08 | 1.57E-07 | 4.50E-07 | No Data  | 7.11E-06 |

Table 9-11 (contd). Ingestion Dose Factors for the Infant Age Group

| Nuclide | Bone     | Liver    | T.Body   | Thyroid  | Kidney   | Lung     | GI-LLI   |
|---------|----------|----------|----------|----------|----------|----------|----------|
| Te-132  | 2.08E-05 | 1.03E-05 | 9.61E-06 | 1.52E-05 | 6.44E-05 | No Data  | 3.81E-05 |
| I-130   | 6.00E-06 | 1.32E-05 | 5.30E-06 | 1.48E-03 | 1.45E-05 | No Data  | 2.83E-06 |
| I-131   | 3.59E-05 | 4.23E-05 | 1.86E-05 | 1.39E-02 | 4.94E-05 | No Data  | 1.51E-06 |
| I-132   | 1.66E-06 | 3.37E-06 | 1.20E-06 | 1.58E-04 | 3.76E-06 | No Data  | 2.73E-06 |
| I-133   | 1.25E-05 | 1.82E-05 | 5.33E-06 | 3.31E-03 | 2.14E-05 | No Data  | 3.08E-06 |
| I-134   | 8.69E-07 | 1.78E-06 | 6.33E-07 | 4.15E-05 | 1.99E-06 | No Data  | 1.84E-06 |
| I-135   | 3.64E-06 | 7.24E-06 | 2.64E-06 | 6.49E-04 | 8.07E-06 | No Data  | 2.62E-06 |
| Cs-134  | 3.77E-04 | 7.03E-04 | 7.10E-05 | No Data  | 1.81E-04 | 7.42E-05 | 1.91E-06 |
| Cs-136  | 4.59E-05 | 1.35E-04 | 5.04E-05 | No Data  | 5.38E-05 | 1.10E-05 | 2.05E-06 |
| Cs-137  | 5.22E-04 | 6.11E-04 | 4.33E-05 | No Data  | 1.64E-04 | 6.64E-05 | 1.91E-06 |
| Cs-138  | 4.81E-07 | 7.82E-07 | 3.79E-07 | No Data  | 3.90E-07 | 6.09E-08 | 1.25E-06 |
| Ba-139  | 8.81E-07 | 5.84E-10 | 2.55E-08 | No Data  | 3.51E-10 | 3.54E-10 | 5.58E-05 |
| Ba-140  | 1.71E-04 | 1.71E-07 | 8.81E-06 | No Data  | 4.06E-08 | 1.05E-07 | 4.20E-05 |
| Ba-141  | 4.25E-07 | 2.91E-10 | 1.34E-08 | No Data  | 1.75E-10 | 1.77E-10 | 5.19E-06 |
| Ba-142  | 1.84E-07 | 1.53E-10 | 9.06E-09 | No Data  | 8.81E-11 | 9.26E-11 | 7.59E-07 |
| La-140  | 2.11E-08 | 8.32E-09 | 2.14E-09 | No Data  | No Data  | No Data  | 9.77E-05 |
| La-142  | 1.10E-09 | 4.04E-10 | 9.67E-11 | No Data  | No Data  | No Data  | 6.86E-05 |
| Ce-141  | 7.87E-08 | 4.80E-08 | 5.65E-09 | No Data  | 1.48E-08 | No Data  | 2.48E-05 |
| Ce-143  | 1.48E-08 | 9.82E-06 | 1.12E-09 | No Data  | 2.86E-09 | No Data  | 5.73E-05 |
| Ce-144  | 2.98E-06 | 1.22E-06 | 1.67E-07 | No Data  | 4.93E-07 | No Data  | 1.71E-04 |
| Pr-143  | 8.13E-08 | 3.04E-08 | 4.03E-09 | No Data  | 1.13E-08 | No Data  | 4.29E-05 |
| Pr-144  | 2.74E-10 | 1.06E-10 | 1.38E-11 | No Data  | 3.84E-11 | No Data  | 4.93E-06 |
| Nd-147  | 5.53E-08 | 5.68E-08 | 3.48E-09 | No Data  | 2.19E-08 | No Data  | 3.60E-05 |
| W-187   | 9.03E-07 | 6.28E-07 | 2.17E-07 | No Data  | No Data  | No Data  | 3.69E-05 |
| Np-239  | 1.11E-08 | 9.93E-10 | 5.61E-10 | No Data  | 1.98E-09 | No Data  | 2.87E-05 |

Table 9-12. Ingestion Dose Factors for the Child Age Group

| Nuclide | Bone     | Liver    | T. Body  | Thyroid  | Kidney   | Lung     | GI-LLI   |
|---------|----------|----------|----------|----------|----------|----------|----------|
| H-3     | No Data  | 2.03E-07 | 2.03E-07 | 2.03E-07 | 2.03E-07 | 2.03E-07 | 2.03E-07 |
| C-14    | 1.21E-05 | 2.42E-06 | 2.42E-06 | 2.42E-06 | 2.42E-06 | 2.42E-06 | 2.42E-06 |
| Na-24   | 5.80E-06 | 5.80E-06 | 5.80E-06 | 5.80E-06 | 5.80E-06 | 5.80E-06 | 5.80E-06 |
| P-32    | 8.25E-04 | 3.86E-05 | 3.18E-05 | No Data  | No Data  | No Data  | 2.28E-05 |
| Cr-51   | No Data  | No Data  | 8.90E-09 | 4.94E-09 | 1.35E-09 | 9.02E-09 | 4.72E-07 |
| Mn-54   | No Data  | 1.07E-05 | 2.85E-06 | No Data  | 3.00E-06 | No Data  | 8.98E-06 |
| Mn-56   | No Data  | 3.34E-07 | 7.54E-08 | No Data  | 4.04E-07 | No Data  | 4.84E-05 |
| Fe-55   | 1.15E-05 | 6.10E-06 | 1.89E-06 | No Data  | No Data  | 3.45E-06 | 1.13E-06 |
| Fe-59   | 1.65E-05 | 2.67E-05 | 1.33E-05 | No Data  | No Data  | 7.74E-06 | 2.78E-05 |
| Co-58   | No Data  | 1.80E-06 | 5.51E-06 | No Data  | No Data  | No Data  | 1.05E-05 |
| Co-60   | No Data  | 5.29E-06 | 1.56E-05 | No Data  | No Data  | No Data  | 2.93E-05 |
| Ni-63   | 5.38E-04 | 2.88E-05 | 1.83E-05 | No Data  | No Data  | No Data  | 1.94E-06 |
| Ni-65   | 2.22E-06 | 2.09E-07 | 1.22E-07 | No Data  | No Data  | No Data  | 2.56E-05 |
| Cu-64   | No Data  | 2.45E-07 | 1.48E-07 | No Data  | 5.92E-07 | No Data  | 1.15E-05 |
| Zn-65   | 1.37E-05 | 3.65E-05 | 2.27E-05 | No Data  | 2.30E-05 | No Data  | 6.41E-06 |
| Zn-69   | 4.38E-08 | 6.33E-08 | 5.85E-09 | No Data  | 3.84E-08 | No Data  | 3.99E-06 |
| Br-83   | No Data  | No Data  | 1.71E-07 | No Data  | No Data  | No Data  | No Data  |
| Br-84   | No Data  | No Data  | 1.98E-07 | No Data  | No Data  | No Data  | No Data  |
| Br-85   | No Data  | No Data  | 9.12E-09 | No Data  | No Data  | No Data  | No Data  |
| Rb-86   | No Data  | 6.70E-05 | 4.12E-05 | No Data  | No Data  | No Data  | 4.31E-06 |
| Rb-88   | No Data  | 1.90E-07 | 1.32E-07 | No Data  | No Data  | No Data  | 9.32E-09 |
| Rb-89   | No Data  | 1.17E-07 | 1.04E-07 | No Data  | No Data  | No Data  | 1.02E-09 |
| Sr-89   | 1.32E-03 | No Data  | 3.77E-05 | No Data  | No Data  | No Data  | 5.11E-05 |
| Sr-90   | 1.70E-02 | No Data  | 4.31E-03 | No Data  | No Data  | No Data  | 2.29E-04 |
| Sr-91   | 2.40E-05 | No Data  | 9.06E-07 | No Data  | No Data  | No Data  | 5.30E-05 |

All values are in (mrem/pCi ingested). They are obtained from Reference 3 (Table E-13). Neither Reference 2 nor Reference 3 contains data for Rh-105, Sb-124, or Sb-125.

Table 9-12 (contd). Ingestion Dose Factors for the Child Age Group

| Nuclide | Bone     | Liver    | T.Body   | Thyroid  | Kidney   | Lung     | GI-LLI   |
|---------|----------|----------|----------|----------|----------|----------|----------|
| Sr-92   | 9.03E-06 | No Data  | 3.62E-07 | No Data  | No Data  | No Data  | 1.71E-04 |
| Y-90    | 4.11E-08 | No Data  | 1.10E-09 | No Data  | No Data  | No Data  | 1.17E-04 |
| Y-91m   | 3.82E-10 | No Data  | 1.39E-11 | No Data  | No Data  | No Data  | 7.48E-07 |
| Y-91    | 6.02E-07 | No Data  | 1.61E-08 | No Data  | No Data  | No Data  | 8.02E-05 |
| Y-92    | 3.60E-09 | No Data  | 1.03E-10 | No Data  | No Data  | No Data  | 1.04E-04 |
| Y-93    | 1.14E-08 | No Data  | 3.13E-10 | No Data  | No Data  | No Data  | 1.70E-04 |
| Zr-95   | 1.16E-07 | 2.55E-08 | 2.27E-08 | No Data  | 3.65E-08 | No Data  | 2.66E-05 |
| Zr-97   | 6.99E-09 | 1.01E-09 | 5.96E-10 | No Data  | 1.45E-09 | No Data  | 1.53E-04 |
| Nb-95   | 2.25E-08 | 8.76E-09 | 6.26E-09 | No Data  | 8.23E-09 | No Data  | 1.62E-05 |
| Mo-99   | No Data  | 1.33E-05 | 3.29E-06 | No Data  | 2.84E-05 | No Data  | 1.10E-05 |
| Tc-99m  | 9.23E-10 | 1.81E-09 | 3.00E-08 | No Data  | 2.63E-08 | 9.19E-10 | 1.03E-06 |
| Tc-101  | 1.07E-09 | 1.12E-09 | 1.42E-08 | No Data  | 1.91E-08 | 5.92E-10 | 3.56E-09 |
| Ru-103  | 7.31E-07 | No Data  | 2.81E-07 | No Data  | 1.84E-06 | No Data  | 1.89E-05 |
| Ru-105  | 6.45E-08 | No Data  | 2.34E-08 | No Data  | 5.67E-07 | No Data  | 4.21E-05 |
| Ru-106  | 1.17E-05 | No Data  | 1.46E-06 | No Data  | 1.58E-05 | No Data  | 1.82E-04 |
| Rh-105  | No Data  | No Data  | No Data  | No Data  | No Data  | No Data  | No Data  |
| Ag-110m | 5.39E-07 | 3.64E-07 | 2.91E-07 | No Data  | 6.78E-07 | No Data  | 4.33E-05 |
| Sb-124  | No Data  | No Data  | No Data  | No Data  | No Data  | No Data  | No Data  |
| Sb-125  | No Data  | No Data  | No Data  | No Data  | No Data  | No Data  | No Data  |
| Te-125m | 1.14E-05 | 3.09E-06 | 1.52E-06 | 3.20E-06 | No Data  | No Data  | 1.10E-05 |
| Te-127m | 2.89E-05 | 7.78E-06 | 3.43E-06 | 6.91E-06 | 8.24E-05 | No Data  | 2.34E-05 |
| Te-127  | 4.71E-07 | 1.27E-07 | 1.01E-07 | 3.26E-07 | 1.34E-06 | No Data  | 1.84E-05 |
| Te-129m | 4.87E-05 | 1.36E-05 | 7.56E-06 | 1.57E-05 | 1.43E-04 | No Data  | 5.94E-05 |
| Te-129  | 1.34E-07 | 3.74E-08 | 3.18E-08 | 9.56E-08 | 3.92E-07 | No Data  | 8.34E-06 |
| Te-131m | 7.20E-06 | 2.49E-06 | 2.65E-06 | 5.12E-06 | 2.41E-05 | No Data  | 1.01E-04 |
| Te-131  | 8.30E-08 | 2.53E-08 | 2.47E-08 | 6.35E-08 | 2.51E-07 | No Data  | 4.36E-07 |

Table 9-12 (contd). Ingestion Dose Factors for the Child Age Group

| Nuclide | Bone     | Liver    | T.Body   | Thyroid  | Kidney   | Lung     | GI-LLI   |
|---------|----------|----------|----------|----------|----------|----------|----------|
| Te-132  | 1.01E-05 | 4.47E-06 | 5.40E-06 | 6.51E-06 | 4.15E-05 | No Data  | 4.50E-05 |
| I-130   | 2.92E-06 | 5.90E-06 | 3.04E-06 | 6.50E-04 | 8.82E-06 | No Data  | 2.76E-06 |
| I-131   | 1.72E-05 | 1.73E-05 | 9.83E-06 | 5.72E-03 | 2.84E-05 | No Data  | 1.54E-06 |
| I-132   | 8.00E-07 | 1.47E-06 | 6.76E-07 | 6.82E-05 | 2.25E-06 | No Data  | 1.73E-06 |
| I-133   | 5.92E-06 | 7.32E-06 | 2.77E-06 | 1.36E-03 | 1.22E-05 | No Data  | 2.95E-06 |
| I-134   | 4.19E-07 | 7.78E-07 | 3.58E-07 | 1.79E-05 | 1.19E-06 | No Data  | 5.16E-07 |
| I-135   | 1.75E-06 | 3.15E-06 | 1.49E-06 | 2.79E-04 | 4.83E-06 | No Data  | 2.40E-06 |
| Cs-134  | 2.34E-04 | 3.84E-04 | 8.10E-05 | No Data  | 1.19E-04 | 4.27E-05 | 2.07E-06 |
| Cs-136  | 2.35E-05 | 6.46E-05 | 4.18E-05 | No Data  | 3.44E-05 | 5.13E-06 | 2.27E-06 |
| Cs-137  | 3.27E-04 | 3.13E-04 | 4.62E-05 | No Data  | 1.02E-04 | 3.67E-05 | 1.96E-06 |
| Cs-138  | 2.28E-07 | 3.17E-07 | 2.01E-07 | No Data  | 2.23E-07 | 2.40E-08 | 1.46E-07 |
| Ba-139  | 4.14E-07 | 2.21E-10 | 1.20E-08 | No Data  | 1.93E-10 | 1.30E-10 | 2.39E-05 |
| Ba-140  | 8.31E-05 | 7.28E-08 | 4.85E-06 | No Data  | 2.37E-08 | 4.34E-08 | 4.21E-05 |
| Ba-141  | 2.00E-07 | 1.12E-10 | 6.51E-09 | No Data  | 9.69E-11 | 6.58E-10 | 1.14E-07 |
| Ba-142  | 8.74E-08 | 6.29E-11 | 4.88E-09 | No Data  | 5.09E-11 | 3.70E-11 | 1.14E-09 |
| La-140  | 1.01E-08 | 3.53E-09 | 1.19E-09 | No Data  | No Data  | No Data  | 9.84E-05 |
| La-142  | 5.24E-10 | 1.67E-10 | 5.23E-11 | No Data  | No Data  | No Data  | 3.31E-05 |
| Ce-141  | 3.97E-08 | 1.98E-08 | 2.94E-09 | No Data  | 8.68E-09 | No Data  | 2.47E-05 |
| Ce-143  | 6.99E-09 | 3.79E-06 | 5.49E-10 | No Data  | 1.59E-09 | No Data  | 5.55E-05 |
| Ce-144  | 2.08E-06 | 6.52E-07 | 1.11E-07 | No Data  | 3.61E-07 | No Data  | 1.70E-04 |
| Pr-143  | 3.93E-08 | 1.18E-08 | 1.95E-09 | No Data  | 6.39E-09 | No Data  | 4.24E-05 |
| Pr-144  | 1.29E-10 | 3.99E-11 | 6.49E-12 | No Data  | 2.11E-11 | No Data  | 8.59E-08 |
| Nd-147  | 2.79E-08 | 2.26E-08 | 1.75E-09 | No Data  | 1.24E-08 | No Data  | 3.58E-05 |
| W-187   | 4.29E-07 | 2.54E-07 | 1.14E-07 | No Data  | No Data  | No Data  | 3.57E-05 |
| Np-239  | 5.25E-09 | 3.77E-10 | 2.65E-10 | No Data  | 1.09E-09 | No Data  | 2.79E-05 |

Table 9-13. Ingestion Dose Factors for the Teenager Age Group

| Nuclide | Bone     | Liver    | T. Body  | Thyroid  | Kidney   | Lung     | GI-LLI   |
|---------|----------|----------|----------|----------|----------|----------|----------|
| H-3     | No Data  | 1.06E-07 | 1.06E-07 | 1.06E-07 | 1.06E-07 | 1.06E-07 | 1.06E-07 |
| C-14    | 4.06E-06 | 8.12E-07 | 8.12E-07 | 8.12E-07 | 8.12E-07 | 8.12E-07 | 8.12E-07 |
| Na-24   | 2.30E-06 | 2.30E-06 | 2.30E-06 | 2.30E-06 | 2.30E-06 | 2.30E-06 | 2.30E-06 |
| P-32    | 2.76E-04 | 1.71E-05 | 1.07E-05 | No Data  | No Data  | No Data  | 2.32E-05 |
| Cr-51   | No Data  | No Data  | 3.60E-09 | 2.00E-09 | 7.89E-10 | 5.14E-09 | 6.05E-07 |
| Mn-54   | No Data  | 5.90E-06 | 1.17E-06 | No Data  | 1.76E-06 | No Data  | 1.21E-05 |
| Mn-56   | No Data  | 1.58E-07 | 2.81E-08 | No Data  | 2.00E-07 | No Data  | 1.04E-05 |
| Fe-55   | 3.78E-06 | 2.68E-06 | 6.25E-07 | No Data  | No Data  | 1.70E-06 | 1.16E-06 |
| Fe-59   | 5.87E-06 | 1.37E-05 | 5.29E-06 | No Data  | No Data  | 4.32E-06 | 3.24E-05 |
| Co-58   | No Data  | 9.72E-07 | 2.24E-06 | No Data  | No Data  | No Data  | 1.34E-05 |
| Co-60   | No Data  | 2.81E-06 | 6.33E-06 | No Data  | No Data  | No Data  | 3.66E-05 |
| Ni-63   | 1.77E-04 | 1.25E-05 | 6.00E-06 | No Data  | No Data  | No Data  | 1.99E-06 |
| Ni-65   | 7.49E-07 | 9.57E-08 | 4.36E-08 | No Data  | No Data  | No Data  | 5.19E-06 |
| Cu-64   | No Data  | 1.15E-07 | 5.41E-08 | No Data  | 2.91E-07 | No Data  | 8.92E-06 |
| Zn-65   | 5.76E-06 | 2.00E-05 | 9.33E-06 | No Data  | 1.28E-05 | No Data  | 8.47E-06 |
| Zn-69   | 1.47E-08 | 2.80E-08 | 1.96E-09 | No Data  | 1.83E-08 | No Data  | 5.16E-08 |
| Br-83   | No Data  | No Data  | 5.74E-08 | No Data  | No Data  | No Data  | No Data  |
| Br-84   | No Data  | No Data  | 7.22E-08 | No Data  | No Data  | No Data  | No Data  |
| Br-85   | No Data  | No Data  | 3.05E-09 | No Data  | No Data  | No Data  | No Data  |
| Rb-86   | No Data  | 2.98E-05 | 1.40E-05 | No Data  | No Data  | No Data  | 4.41E-06 |
| Rb-88   | No Data  | 8.52E-08 | 4.54E-08 | No Data  | No Data  | No Data  | 7.30E-15 |
| Rb-89   | No Data  | 5.50E-08 | 3.89E-08 | No Data  | No Data  | No Data  | 8.43E-17 |
| Sr-89   | 4.40E-04 | No Data  | 1.26E-05 | No Data  | No Data  | No Data  | 5.24E-05 |
| Sr-90   | 8.30E-03 | No Data  | 2.05E-03 | No Data  | No Data  | No Data  | 2.33E-04 |
| Sr-91   | 8.07E-06 | No Data  | 3.21E-07 | No Data  | No Data  | No Data  | 3.66E-05 |

All values are in (mrem/pCi ingested). They are obtained from Reference 3 (Table E-12). Neither Reference 2 nor Reference 3 contains data for Rh-105, Sb-124, or Sb-125.

Table 9-13 (contd). Ingestion Dose Factors for the Teenager Age Group

| Nuclide | Bone     | Liver    | T.Body   | Thyroid  | Kidney   | Lung     | GI-LLI   |
|---------|----------|----------|----------|----------|----------|----------|----------|
| Sr-92   | 3.05E-06 | No Data  | 1.30E-07 | No Data  | No Data  | No Data  | 7.77E-05 |
| Y-90    | 1.37E-08 | No Data  | 3.69E-10 | No Data  | No Data  | No Data  | 1.13E-04 |
| Y-91m   | 1.29E-10 | No Data  | 4.93E-12 | No Data  | No Data  | No Data  | 6.09E-09 |
| Y-91    | 2.01E-07 | No Data  | 5.39E-09 | No Data  | No Data  | No Data  | 8.24E-05 |
| Y-92    | 1.21E-09 | No Data  | 3.50E-11 | No Data  | No Data  | No Data  | 3.32E-05 |
| Y-93    | 3.83E-09 | No Data  | 1.05E-10 | No Data  | No Data  | No Data  | 1.17E-04 |
| Zr-95   | 4.12E-08 | 1.30E-08 | 8.94E-09 | No Data  | 1.91E-08 | No Data  | 3.00E-05 |
| Zr-97   | 2.37E-09 | 4.69E-10 | 2.16E-10 | No Data  | 7.11E-10 | No Data  | 1.27E-04 |
| Nb-95   | 8.22E-09 | 4.56E-09 | 2.51E-09 | No Data  | 4.42E-09 | No Data  | 1.95E-05 |
| Mo-99   | No Data  | 6.03E-06 | 1.15E-06 | No Data  | 1.38E-05 | No Data  | 1.08E-05 |
| Tc-99m  | 3.32E-10 | 9.26E-10 | 1.20E-08 | No Data  | 1.38E-08 | 5.14E-10 | 6.08E-07 |
| Tc-101  | 3.60E-10 | 5.12E-10 | 5.03E-09 | No Data  | 9.26E-09 | 3.12E-10 | 8.75E-17 |
| Ru-103  | 2.55E-07 | No Data  | 1.09E-07 | No Data  | 8.99E-07 | No Data  | 2.13E-05 |
| Ru-105  | 2.18E-08 | No Data  | 8.46E-09 | No Data  | 2.75E-07 | No Data  | 1.76E-05 |
| Ru-106  | 3.92E-06 | No Data  | 4.94E-07 | No Data  | 7.56E-06 | No Data  | 1.88E-04 |
| Rh-105  | No Data  | No Data  | No Data  | No Data  | No Data  | No Data  | No Data  |
| Ag-110m | 2.05E-07 | 1.94E-07 | 1.18E-07 | No Data  | 3.70E-07 | No Data  | 5.45E-05 |
| Sb-124  | No Data  | No Data  | No Data  | No Data  | No Data  | No Data  | No Data  |
| Sb-125  | No Data  | No Data  | No Data  | No Data  | No Data  | No Data  | No Data  |
| Te-125m | 3.83E-06 | 1.38E-06 | 5.12E-07 | 1.07E-06 | No Data  | No Data  | 1.13E-05 |
| Te-127m | 9.67E-06 | 3.43E-06 | 1.15E-06 | 2.30E-06 | 3.92E-05 | No Data  | 2.41E-05 |
| Te-127  | 1.58E-07 | 5.60E-08 | 3.40E-08 | 1.09E-07 | 6.40E-07 | No Data  | 1.22E-05 |
| Te-129m | 1.63E-05 | 6.05E-06 | 2.58E-06 | 5.26E-06 | 6.82E-05 | No Data  | 6.12E-05 |
| Te-129  | 4.48E-08 | 1.67E-08 | 1.09E-08 | 3.20E-08 | 1.88E-07 | No Data  | 2.45E-07 |
| Te-131m | 2.44E-06 | 1.17E-06 | 9.76E-07 | 1.76E-06 | 1.22E-05 | No Data  | 9.39E-05 |
| Te-131  | 2.79E-08 | 1.15E-08 | 8.72E-09 | 2.15E-08 | 1.22E-07 | No Data  | 2.29E-09 |

Table 9-13 (contd). Ingestion Dose Factors for the Teenager Age Group

| Nuclide | Bone     | Liver    | T.Body   | Thyroid  | Kidney   | Lung     | GI-LLI   |
|---------|----------|----------|----------|----------|----------|----------|----------|
| Te-132  | 3.49E-06 | 2.21E-06 | 2.08E-06 | 2.33E-06 | 2.12E-05 | No Data  | 7.00E-05 |
| I-130   | 1.03E-06 | 2.98E-06 | 1.19E-06 | 2.43E-04 | 4.59E-06 | No Data  | 2.29E-06 |
| I-131   | 5.85E-06 | 8.19E-06 | 4.40E-06 | 2.39E-03 | 1.41E-05 | No Data  | 1.62E-06 |
| I-132   | 2.79E-07 | 7.30E-07 | 2.62E-07 | 2.46E-05 | 1.15E-06 | No Data  | 3.18E-07 |
| I-133   | 2.01E-06 | 3.41E-06 | 1.04E-06 | 4.76E-04 | 5.98E-06 | No Data  | 2.58E-06 |
| I-134   | 1.46E-07 | 3.87E-07 | 1.39E-07 | 6.45E-06 | 6.10E-07 | No Data  | 5.10E-09 |
| I-135   | 6.10E-07 | 1.57E-06 | 5.82E-07 | 1.01E-04 | 2.48E-06 | No Data  | 1.74E-06 |
| Cs-134  | 8.37E-05 | 1.97E-04 | 9.14E-05 | No Data  | 6.26E-05 | 2.39E-05 | 2.45E-06 |
| Cs-136  | 8.59E-06 | 3.38E-05 | 2.27E-05 | No Data  | 1.84E-05 | 2.90E-06 | 2.72E-06 |
| Cs-137  | 1.12E-04 | 1.49E-04 | 5.19E-05 | No Data  | 5.07E-05 | 1.97E-05 | 2.12E-06 |
| Cs-138  | 7.76E-08 | 1.49E-07 | 7.45E-08 | No Data  | 1.10E-07 | 1.28E-08 | 6.76E-11 |
| Ba-139  | 1.39E-07 | 9.78E-11 | 4.05E-09 | No Data  | 9.22E-11 | 6.74E-11 | 1.24E-06 |
| Ba-140  | 2.84E-05 | 3.48E-08 | 1.83E-06 | No Data  | 1.18E-08 | 2.34E-08 | 4.38E-05 |
| Ba-141  | 6.71E-08 | 5.01E-11 | 2.24E-09 | No Data  | 4.65E-11 | 3.43E-11 | 1.43E-13 |
| Ba-142  | 2.99E-08 | 2.99E-11 | 1.84E-09 | No Data  | 2.53E-11 | 1.99E-11 | 9.18E-20 |
| La-140  | 3.48E-09 | 1.71E-09 | 4.55E-10 | No Data  | No Data  | No Data  | 9.82E-05 |
| La-142  | 1.79E-10 | 7.95E-11 | 1.98E-11 | No Data  | No Data  | No Data  | 2.42E-06 |
| Ce-141  | 1.33E-08 | 8.88E-09 | 1.02E-09 | No Data  | 4.18E-09 | No Data  | 2.54E-05 |
| Ce-143  | 2.35E-09 | 1.71E-06 | 1.91E-10 | No Data  | 7.67E-10 | No Data  | 5.14E-05 |
| Ce-144  | 6.96E-07 | 2.88E-07 | 3.74E-08 | No Data  | 1.72E-07 | No Data  | 1.75E-04 |
| Pr-143  | 1.31E-08 | 5.23E-09 | 6.52E-10 | No Data  | 3.04E-09 | No Data  | 4.31E-05 |
| Pr-144  | 4.30E-11 | 1.76E-11 | 2.18E-12 | No Data  | 1.01E-11 | No Data  | 4.74E-14 |
| Nd-147  | 9.38E-09 | 1.02E-08 | 6.11E-10 | No Data  | 5.99E-09 | No Data  | 3.68E-05 |
| W-187   | 1.46E-07 | 1.19E-07 | 4.17E-08 | No Data  | No Data  | No Data  | 3.22E-05 |
| Np-239  | 1.76E-09 | 1.66E-10 | 9.22E-11 | No Data  | 5.21E-10 | No Data  | 2.67E-05 |

Table 9-14. Ingestion Dose Factors for the Adult Age Group

| Nuclide | Bone     | Liver    | T. Body  | Thyroid  | Kidney   | Lung     | GI-LLI   |
|---------|----------|----------|----------|----------|----------|----------|----------|
| H-3     | No Data  | 1.05E-07 | 1.05E-07 | 1.05E-07 | 1.05E-07 | 1.05E-07 | 1.05E-07 |
| C-14    | 2.84E-06 | 5.68E-07 | 5.68E-07 | 5.68E-07 | 5.68E-07 | 5.68E-07 | 5.68E-07 |
| Na-24   | 1.70E-06 | 1.70E-06 | 1.70E-06 | 1.70E-06 | 1.70E-06 | 1.70E-06 | 1.70E-06 |
| P-32    | 1.93E-04 | 1.20E-05 | 7.46E-06 | No Data  | No Data  | No Data  | 2.17E-05 |
| Cr-51   | No Data  | No Data  | 2.66E-09 | 1.59E-09 | 5.86E-10 | 3.53E-09 | 6.69E-07 |
| Mn-54   | No Data  | 4.57E-06 | 8.72E-07 | No Data  | 1.36E-06 | No Data  | 1.40E-05 |
| Mn-56   | No Data  | 1.15E-07 | 2.04E-08 | No Data  | 1.46E-07 | No Data  | 3.67E-06 |
| Fe-55   | 2.75E-06 | 1.90E-06 | 4.43E-07 | No Data  | No Data  | 1.06E-06 | 1.09E-06 |
| Fe-59   | 4.34E-06 | 1.02E-05 | 3.91E-06 | No Data  | No Data  | 2.85E-06 | 3.40E-05 |
| Co-58   | No Data  | 7.45E-07 | 1.67E-06 | No Data  | No Data  | No Data  | 1.51E-05 |
| Co-60   | No Data  | 2.14E-06 | 4.72E-06 | No Data  | No Data  | No Data  | 4.02E-05 |
| Ni-63   | 1.30E-04 | 9.01E-06 | 4.36E-06 | No Data  | No Data  | No Data  | 1.88E-06 |
| Ni-65   | 5.28E-07 | 6.86E-08 | 3.13E-08 | No Data  | No Data  | No Data  | 1.74E-06 |
| Cu-64   | No Data  | 8.33E-08 | 3.91E-08 | No Data  | 2.10E-07 | No Data  | 7.10E-06 |
| Zn-65   | 4.84E-06 | 1.54E-05 | 6.96E-06 | No Data  | 1.03E-05 | No Data  | 9.70E-06 |
| Zn-69   | 1.03E-08 | 1.97E-08 | 1.37E-09 | No Data  | 1.28E-08 | No Data  | 2.96E-09 |
| Br-83   | No Data  | No Data  | 4.02E-08 | No Data  | No Data  | No Data  | 5.79E-08 |
| Br-84   | No Data  | No Data  | 5.21E-08 | No Data  | No Data  | No Data  | 4.09E-13 |
| Br-85   | No Data  | No Data  | 2.14E-09 | No Data  | No Data  | No Data  | No Data  |
| Rb-86   | No Data  | 2.11E-05 | 9.83E-06 | No Data  | No Data  | No Data  | 4.16E-06 |
| Rb-88   | No Data  | 6.05E-08 | 3.21E-08 | No Data  | No Data  | No Data  | 8.36E-19 |
| Rb-89   | No Data  | 4.01E-08 | 2.82E-08 | No Data  | No Data  | No Data  | 2.33E-21 |
| Sr-89   | 3.08E-04 | No Data  | 8.84E-06 | No Data  | No Data  | No Data  | 4.94E-05 |
| Sr-90   | 7.58E-03 | No Data  | 1.86E-03 | No Data  | No Data  | No Data  | 2.19E-04 |
| Sr-91   | 5.67E-06 | No Data  | 2.29E-07 | No Data  | No Data  | No Data  | 2.70E-05 |

All values are in (mrem/pCi ingested). They are obtained from Reference 3 (Table E-11), except as follows: Reference 2 (Table A-3) for Rh-105, Sb-124, and Sb-125.

Table 9-14 (contd). Ingestion Dose Factors for the Adult Age Group

| Nuclide | Bone     | Liver    | T.Body   | Thyroid  | Kidney   | Lung     | GI-LLI   |
|---------|----------|----------|----------|----------|----------|----------|----------|
| Sr-92   | 2.15E-06 | No Data  | 9.30E-08 | No Data  | No Data  | No Data  | 4.26E-05 |
| Y-90    | 9.62E-09 | No Data  | 2.58E-10 | No Data  | No Data  | No Data  | 1.02E-04 |
| Y-91m   | 9.09E-11 | No Data  | 3.52E-12 | No Data  | No Data  | No Data  | 2.67E-10 |
| Y-91    | 1.41E-07 | No Data  | 3.77E-09 | No Data  | No Data  | No Data  | 7.76E-05 |
| Y-92    | 8.45E-10 | No Data  | 2.47E-11 | No Data  | No Data  | No Data  | 1.48E-05 |
| Y-93    | 2.68E-09 | No Data  | 7.40E-11 | No Data  | No Data  | No Data  | 8.50E-05 |
| Zr-95   | 3.04E-08 | 9.75E-09 | 6.60E-09 | No Data  | 1.53E-08 | No Data  | 3.09E-05 |
| Zr-97   | 1.68E-09 | 3.39E-10 | 1.55E-10 | No Data  | 5.12E-10 | No Data  | 1.05E-04 |
| Nb-95   | 6.22E-09 | 3.46E-09 | 1.86E-09 | No Data  | 3.42E-09 | No Data  | 2.10E-05 |
| Mo-99   | No Data  | 4.31E-06 | 8.20E-07 | No Data  | 9.76E-06 | No Data  | 9.99E-06 |
| Tc-99m  | 2.47E-10 | 6.98E-10 | 8.89E-09 | No Data  | 1.06E-08 | 3.42E-10 | 4.13E-07 |
| Tc-101  | 2.54E-10 | 3.66E-10 | 3.59E-09 | No Data  | 6.59E-09 | 1.87E-10 | 1.10E-21 |
| Ru-103  | 1.85E-07 | No Data  | 7.97E-08 | No Data  | 7.06E-07 | No Data  | 2.16E-05 |
| Ru-105  | 1.54E-08 | No Data  | 6.08E-09 | No Data  | 1.99E-07 | No Data  | 9.42E-06 |
| Ru-106  | 2.75E-06 | No Data  | 3.48E-07 | No Data  | 5.31E-06 | No Data  | 1.78E-04 |
| Rh-105  | 1.22E-07 | 8.86E-08 | 5.83E-08 | No Data  | 3.76E-07 | No Data  | 1.41E-05 |
| Ag-110m | 1.60E-07 | 1.48E-07 | 8.79E-08 | No Data  | 2.91E-07 | No Data  | 6.04E-05 |
| Sb-124  | 2.81E-06 | 5.30E-08 | 1.11E-06 | 6.79E-09 | No Data  | 2.18E-06 | 7.95E-05 |
| Sb-125  | 2.23E-06 | 2.40E-08 | 4.48E-07 | 1.98E-09 | No Data  | 2.33E-04 | 1.97E-05 |
| Te-125m | 2.68E-06 | 9.71E-07 | 3.59E-07 | 8.06E-07 | 1.09E-05 | No Data  | 1.07E-05 |
| Te-127m | 6.77E-06 | 2.42E-06 | 8.25E-07 | 1.73E-06 | 2.75E-05 | No Data  | 2.27E-05 |
| Te-127  | 1.10E-07 | 3.95E-08 | 2.38E-08 | 8.15E-08 | 4.48E-07 | No Data  | 8.68E-06 |
| Te-129m | 1.15E-05 | 4.29E-06 | 1.82E-06 | 3.95E-06 | 4.80E-05 | No Data  | 5.79E-05 |
| Te-129  | 3.14E-08 | 1.18E-08 | 7.65E-09 | 2.41E-08 | 1.32E-07 | No Data  | 2.37E-08 |
| Te-131m | 1.73E-06 | 8.46E-07 | 7.05E-07 | 1.34E-06 | 8.57E-06 | No Data  | 8.40E-05 |
| Te-131  | 1.97E-08 | 8.23E-09 | 6.22E-09 | 1.62E-08 | 8.63E-08 | No Data  | 2.79E-09 |

Table 9-14 (contd). Ingestion Dose Factors for the Adult Age Group

| Nuclide | Bone     | Liver    | T.Body   | Thyroid  | Kidney   | Lung     | GI-LLI   |
|---------|----------|----------|----------|----------|----------|----------|----------|
| Te-132  | 2.52E-06 | 1.63E-06 | 1.53E-06 | 1.80E-06 | 1.57E-05 | No Data  | 7.71E-05 |
| I-130   | 7.56E-07 | 2.23E-06 | 8.80E-07 | 1.89E-04 | 3.48E-06 | No Data  | 1.92E-06 |
| I-131   | 4.16E-06 | 5.95E-06 | 3.41E-06 | 1.95E-03 | 1.02E-05 | No Data  | 1.57E-06 |
| I-132   | 2.03E-07 | 5.43E-07 | 1.90E-07 | 1.90E-05 | 8.65E-07 | No Data  | 1.02E-07 |
| I-133   | 1.42E-06 | 2.47E-06 | 7.53E-07 | 3.63E-04 | 4.31E-06 | No Data  | 2.22E-06 |
| I-134   | 1.06E-07 | 2.88E-07 | 1.03E-07 | 4.99E-06 | 4.58E-07 | No Data  | 2.51E-10 |
| I-135   | 4.43E-07 | 1.16E-06 | 4.28E-07 | 7.65E-05 | 1.86E-06 | No Data  | 1.31E-06 |
| Cs-134  | 6.22E-05 | 1.48E-04 | 1.21E-04 | No Data  | 4.79E-05 | 1.59E-05 | 2.59E-06 |
| Cs-136  | 6.51E-06 | 2.57E-05 | 1.85E-05 | No Data  | 1.43E-05 | 1.96E-06 | 2.92E-06 |
| Cs-137  | 7.97E-05 | 1.09E-04 | 7.14E-05 | No Data  | 3.70E-05 | 1.23E-05 | 2.11E-06 |
| Cs-138  | 5.52E-08 | 1.09E-07 | 5.40E-08 | No Data  | 8.01E-08 | 7.91E-09 | 4.65E-13 |
| Ba-139  | 9.70E-08 | 6.91E-11 | 2.84E-09 | No Data  | 6.46E-11 | 3.92E-11 | 1.72E-07 |
| Ba-140  | 2.03E-05 | 2.55E-08 | 1.33E-06 | No Data  | 8.67E-09 | 1.46E-08 | 4.18E-05 |
| Ba-141  | 4.71E-08 | 3.56E-11 | 1.59E-09 | No Data  | 3.31E-11 | 2.02E-11 | 2.22E-17 |
| Ba-142  | 2.13E-08 | 2.19E-11 | 1.34E-09 | No Data  | 1.85E-11 | 1.24E-11 | 3.00E-26 |
| La-140  | 2.50E-09 | 1.26E-09 | 3.33E-10 | No Data  | No Data  | No Data  | 9.25E-05 |
| La-142  | 1.28E-10 | 5.82E-11 | 1.45E-11 | No Data  | No Data  | No Data  | 4.25E-07 |
| Ce-141  | 9.36E-09 | 6.33E-09 | 7.18E-10 | No Data  | 2.94E-09 | No Data  | 2.42E-05 |
| Ce-143  | 1.65E-09 | 1.22E-06 | 1.35E-10 | No Data  | 5.37E-10 | No Data  | 4.56E-05 |
| Ce-144  | 4.88E-07 | 2.04E-07 | 2.62E-08 | No Data  | 1.21E-07 | No Data  | 1.65E-04 |
| Pr-143  | 9.20E-09 | 3.69E-09 | 4.56E-10 | No Data  | 2.13E-09 | No Data  | 4.03E-05 |
| Pr-144  | 3.01E-11 | 1.25E-11 | 1.53E-12 | No Data  | 7.05E-12 | No Data  | 4.33E-18 |
| Nd-147  | 6.29E-09 | 7.27E-09 | 4.35E-10 | No Data  | 4.25E-09 | No Data  | 3.49E-05 |
| W-187   | 1.03E-07 | 8.61E-08 | 3.01E-08 | No Data  | No Data  | No Data  | 2.82E-05 |
| Np-239  | 1.19E-09 | 1.17E-10 | 6.45E-11 | No Data  | 3.65E-10 | No Data  | 2.40E-05 |

Table 9-15. External Dose Factors for Standing on Contaminated Ground

| Nuclide | T. Body  | Skin     |
|---------|----------|----------|
| H-3     | 0.00     | 0.00     |
| C-14    | 0.00     | 0.00     |
| Na-24   | 2.50E-08 | 2.90E-08 |
| P-32    | 0.00     | 0.00     |
| Cr-51   | 2.20E-10 | 2.60E-10 |
| Mn-54   | 5.80E-09 | 6.80E-09 |
| Mn-56   | 1.10E-08 | 1.30E-08 |
| Fe-55   | 0.00     | 0.00     |
| Fe-59   | 8.00E-09 | 9.40E-09 |
| Co-58   | 7.00E-09 | 8.20E-09 |
| Co-60   | 1.70E-08 | 2.00E-08 |
| Ni-63   | 0.00     | 0.00     |
| Ni-65   | 3.70E-09 | 4.30E-09 |
| Cu-64   | 1.50E-09 | 1.70E-09 |
| Zn-65   | 4.00E-09 | 4.60E-09 |
| Zn-69   | 0.00     | 0.00     |
| Br-83   | 6.40E-11 | 9.30E-11 |
| Br-84   | 1.20E-08 | 1.40E-08 |
| Br-85   | 0.00     | 0.00     |
| Rb-86   | 6.30E-10 | 7.20E-10 |
| Rb-88   | 3.50E-09 | 4.00E-09 |
| Rb-89   | 1.50E-08 | 1.80E-08 |
| Sr-89   | 5.60E-13 | 6.50E-13 |
| Sr-90   | 0.00     | 0.00     |

| Nuclide | T. Body  | Skin     |
|---------|----------|----------|
| Sr-91   | 7.10E-09 | 8.30E-09 |
| Sr-92   | 9.00E-09 | 1.00E-08 |
| Y-90    | 2.20E-12 | 2.60E-12 |
| Y-91m   | 3.80E-09 | 4.40E-09 |
| Y-91    | 2.40E-11 | 2.70E-11 |
| Y-92    | 1.60E-09 | 1.90E-09 |
| Y-93    | 5.70E-10 | 7.80E-10 |
| Zr-95   | 5.00E-09 | 5.80E-09 |
| Zr-97   | 5.50E-09 | 6.40E-09 |
| Nb-95   | 5.10E-09 | 6.00E-09 |
| Mo-99   | 1.90E-09 | 2.20E-09 |
| Tc-99m  | 9.60E-10 | 1.10E-09 |
| Tc-101  | 2.70E-09 | 3.00E-09 |
| Ru-103  | 3.60E-09 | 4.20E-09 |
| Ru-105  | 4.50E-09 | 5.10E-09 |
| Ru-106  | 1.50E-09 | 1.80E-09 |
| Rh-105  | 6.60E-10 | 7.70E-10 |
| Ag-110m | 1.80E-08 | 2.10E-08 |
| Sb-124  | 1.30E-08 | 1.50E-08 |
| Sb-125  | 3.10E-09 | 3.50E-09 |
| Te-125m | 3.50E-11 | 4.80E-11 |
| Te-127m | 1.10E-12 | 1.30E-12 |
| Te-127  | 1.00E-11 | 1.10E-11 |
| Te-129m | 7.70E-10 | 9.00E-10 |

All values are in (mrem/h) per (pCi/m<sup>2</sup>). They are obtained from Reference 3 (Table E-6), except as follows: Reference 2 (Table A-7) for Rh-105, Sb-124, and Sb-125.

Table 9-15 (contd). External Dose Factors for Standing on Contaminated Ground

| Nuclide | T.Body   | Skin     |
|---------|----------|----------|
| Te-129  | 7.10E-10 | 8.40E-10 |
| Te-131m | 8.40E-09 | 9.90E-09 |
| Te-131  | 2.20E-09 | 2.60E-06 |
| Te-132  | 1.70E-09 | 2.00E-09 |
| I-130   | 1.40E-08 | 1.70E-08 |
| I-131   | 2.80E-09 | 3.40E-09 |
| I-132   | 1.70E-08 | 2.00E-08 |
| I-133   | 3.70E-09 | 4.50E-09 |
| I-134   | 1.60E-08 | 1.90E-08 |
| I-135   | 1.20E-08 | 1.40E-08 |
| Cs-134  | 1.20E-08 | 1.40E-08 |
| Cs-136  | 1.50E-08 | 1.70E-08 |
| Cs-137  | 4.20E-09 | 4.90E-09 |
| Cs-138  | 2.10E-08 | 2.40E-08 |
| Ba-139  | 2.40E-09 | 2.70E-09 |
| Ba-140  | 2.10E-09 | 2.40E-09 |
| Ba-141  | 4.30E-09 | 4.90E-09 |
| Ba-142  | 7.90E-09 | 9.00E-09 |
| La-140  | 1.50E-08 | 1.70E-08 |
| La-142  | 1.50E-08 | 1.80E-08 |
| Ce-141  | 5.50E-10 | 6.20E-10 |
| Ce-143  | 2.20E-09 | 2.50E-09 |
| Ce-144  | 3.20E-10 | 3.70E-10 |
| Pr-143  | 0.00     | 0.00     |
| Pr-144  | 2.00E-10 | 2.30E-10 |
| Nd-147  | 1.00E-09 | 1.20E-09 |
| W-187   | 3.10E-09 | 3.60E-09 |
| Np-239  | 9.50E-10 | 1.10E-09 |

CHAPTER 10  
DEFINITIONS OF EFFLUENT CONTROL TERMS

The terms defined in this chapter are used in the presentation of the above chapters. These terms are shown in all capital letters to indicate that they are specifically defined.

#### 10.1 TERMS SPECIFIC TO THE ODCM

The following terms are used in the ODCM, but are not found in the Technical Specifications:

##### ACTION(S)

An ACTION shall be that part of a control that prescribes remedial measures required under designated conditions.

##### BATCH RELEASE

A BATCH RELEASE is the discharge of wastes of a discrete volume. Prior to sampling for analyses, each liquid batch shall be isolated and then thoroughly mixed by a method described in the ODCM to assure representative sampling.

##### COMPOSITE SAMPLE

A COMPOSITE SAMPLE is one which contains material from multiple waste releases, in which the quantity of sample is proportional to the quantity of waste discharged, and in which the method of sampling employed results in a specimen that is representative of the wastes released. Prior to analyses, all liquid samples that are to be aliquotted for a COMPOSITE SAMPLE shall be mixed thoroughly, in order for the COMPOSITE SAMPLE to be representative of the effluent release.

When assessing the consequences of a waste release at the pre-release or post-release stage, the most recent available COMPOSITE SAMPLE results for the applicable release pathway may be used.

##### CONTINUOUS RELEASE

A CONTINUOUS RELEASE is the discharge of wastes of a non-discrete volume, e.g., from a volume within a system that has an input flow during the continuous release. To be representative of the quantities and concentrations of radioactive materials in CONTINUOUS RELEASES of liquid effluents, samples shall be collected in proportion to the rate of flow of the effluent stream or to the quantity of liquid waste discharged.

##### FREQUENCY NOTATION

The FREQUENCY NOTATION specified for the performance of surveillance requirements shall correspond to the intervals defined below, with a maximum allowable extension not to exceed 25% of the surveillance interval.

| <u>NOTATION</u>    | <u>FREQUENCY</u>            |
|--------------------|-----------------------------|
| S (Once per shift) | At least once per 12 hours. |
| D (Daily)          | At least once per 24 hours. |
| W (Weekly)         | At least once per 7 days.   |
| M (Monthly)        | At least once per 31 days.  |

|                    |                                    |
|--------------------|------------------------------------|
| SM (Semi-Monthly)  | At least twice per calendar month* |
| Q (Quarterly)      | At least once per 92 days.         |
| SA (Semi-annually) | At least once per 184 days.        |
| R (Refueling)      | At least once per 18 months.       |
| S/U (Startup)      | Prior to each reactor startup.     |
| NA                 | Not applicable.                    |
| P (Prior)          | Completed prior to each release.   |

\*Semi-monthly sampling means one sample on two different weeks of every calendar month. No other grace period applies.

#### GASEOUS WASTE PROCESSING SYSTEM

A GASEOUS WASTE PROCESSING SYSTEM shall be any system designed and installed to reduce radioactive gaseous effluents by collecting Reactor Coolant System offgases from the Reactor Coolant System and providing for delay or holdup for the purpose of reducing the total radioactivity prior to release to the environment.

#### LIQUID RADWASTE TREATMENT SYSTEM

A LIQUID RADWASTE TREATMENT SYSTEM is any system designed and installed to reduce radioactive materials in liquid effluents by systematic collection, retention, and processing through filtration, evaporation, separation and/or ion exchange treatment. This system consists of at least one collection tank, one evaporator or demineralizer system, one post-treatment tank and associated components providing for treatment flow and functional control.

#### MAJOR CHANGES TO RADIOACTIVE WASTE TREATMENT SYSTEMS

For the purposes of the ODCM, MAJOR CHANGES TO RADIOACTIVE WASTE TREATMENT SYSTEMS include the following changes to such systems:

- (1) Major changes in process equipment, components, structures, or effluent monitoring instrumentation as described in the Final Safety Analysis Report (FSAR) or as evaluated in the Nuclear Regulatory Commission staff's Safety Evaluation Report (SER) (e.g., deletion of evaporators and installation of demineralizers);
- (2) Changes in the design of radwaste treatment systems that could significantly increase quantities of effluents released from those previously considered in the FSAR and SER;
- (3) Changes in system design which may invalidate the accident analysis as described in the SER (e.g., changes in tank capacity that would alter the curies released); or
- (4) Changes in system design that could potentially result in a significant increase in occupational exposure of operating personnel (e.g., use of temporary equipment without adequate shielding provisions).

MEMBER(S) OF THE PUBLIC<sup>1</sup>

A MEMBER OF THE PUBLIC means any individual except when that individual is receiving an *occupational dose*<sup>2</sup>. This category may include persons who use portions of the site for recreational, occupational, or other purposes not associated with the plant.

MINIMUM DETECTABLE CONCENTRATION

The MINIMUM DETECTABLE CONCENTRATION (MDC) is defined, for purposes of the controls in this ODCM, as the smallest concentration of radioactive material in a sample that will yield a net count above system background and that will be detected with 95-percent probability, with only 5-percent probability of falsely concluding that a blank observation represents a "real" signal.

For a particular measurement system, which may include radiochemical separation, the MDC for a given radionuclide is determined as follows (Reference 18):

where:

MDC = the *a priori* MINIMUM DETECTABLE CONCENTRATION ( $\mu\text{Ci}$  per unit mass or volume).

$$MDC = \frac{\frac{2.71}{t_s} + 3.29 \sqrt{R_b \left( \frac{1}{t_s} + \frac{1}{t_b} \right)}}{E \cdot V \cdot 2.22 \times 10^6 \cdot Y \cdot e^{-\lambda \Delta t}}$$

$R_b$  = the background counting rate, or the counting rate of a blank sample, as appropriate (counts per minute).

$t_s$  = the length of the sample counting period (minutes).

$t_b$  = the length of the background counting period (minutes).

$E$  = the counting efficiency (counts per disintegration)

$V$  = the sample size (units of mass or volume).

$2.22 \times 10^6$  = the number of disintegrations per minute per  $\mu\text{Ci}$ .

$Y$  = the fractional radiochemical yield, when applicable.

$\lambda$  = the radioactive decay constant for the given radionuclide ( $\text{h}^{-1}$ ).

Values of  $\lambda$  used in effluent calculations should be based on decay data from a recognized and current source, such as Reference 20.

$\Delta t$  = for effluent samples, the elapsed time between the midpoint of sample collection and the time of counting (h); for environmental samples, the elapsed time between the end of sample collection and the time of counting (h).

<sup>1</sup> The italicized terms in this definition, which are not otherwise used in this ODCM, shall have the definitions assigned to them by 10 CFR 20.1003.

<sup>2</sup> Except as delineated in other parts of 10 CFR chapter I.

Typical values of E, V, Y, and  $\Delta t$  should be used in the calculation. It should be recognized that the MDC is defined as an *a priori* (before the fact) limit representing the capability of a measurement system, and not as an *a posteriori* (after the fact) limit for a particular measurement.

#### PRINCIPAL GAMMA EMITTERS

The PRINCIPAL GAMMA EMITTERS for which the MINIMUM DETECTABLE CONCENTRATION (MDC) limit applies include exclusively the following radionuclides:

- For liquid radioactive effluents: Mn-54, Fe-59, Co-58, Co-60, Zn-65, Mo-99, Cs-134, Cs-137, and Ce-141. Ce-144 shall also be measured, but with an MDC of  $5 \times 10^{-6}$   $\mu\text{Ci/mL}$ .
- For gaseous radioactive effluents: In noble gas releases, Kr-87, Kr-88, Xe-133, Xe-133m, Xe-135, Xe-138; and in particulate releases, Mn-54, Fe-59, Co-58, Co-60, Zn-65, Mo-99, Cs-134, Cs-137, Ce-141, and Ce-144.
- For environmental media: The gamma emitters specifically listed in Table 4-3.

These lists do not mean that only these nuclides are to be considered. Other gamma peaks that are identifiable, together with those of the above nuclides, shall also be analyzed and reported in the Radioactive Effluent Release Report, the Annual Radiological Environmental Operating Report, or other applicable report(s).

#### SITE BOUNDARY

For the purpose of effluent controls defined in the ODCM, the SITE BOUNDARY shall be as shown in Figure 4-1.

#### SOURCE CHECK

A SOURCE CHECK shall be the qualitative assessment of channel response when the channel sensor is exposed to a source of increased radioactivity.

#### UNRESTRICTED AREA

The UNRESTRICTED AREA shall be any area access to which is neither limited nor controlled by the licensee, or any area within the SITE BOUNDARY used for residential quarters or for industrial, commercial, institutional, and/or recreational purposes.

#### VENTILATION EXHAUST TREATMENT SYSTEM

The VENTILATION EXHAUST TREATMENT SYSTEM is any system designed and installed to reduce gaseous radioiodine or radioactive material in particulate form in effluents, by passing ventilation or vent exhaust gases through charcoal adsorbers and/or HEPA filters, for the purpose of removing iodines or particulates from the gaseous exhaust stream prior to the release to the environment. (Such a system is not considered to have any effect on any noble gas effluents). Engineered Safety Feature (ESF) atmospheric cleanup systems are not considered to be VENTILATION EXHAUST TREATMENT SYSTEM components.

## 10.2 TERMS DEFINED IN THE TECHNICAL SPECIFICATIONS

The following terms are defined in the Technical Specifications, Section 1.0. Because they are used throughout the Limits of Operation sections of the ODCM, they are presented here for convenience. In the event of discrepancies between the definitions below and those in the Technical Specifications, the Technical Specification definitions shall take precedence.

### CHANNEL CALIBRATION

A CHANNEL CALIBRATION shall be the adjustment, as necessary, of the channel, such that it responds within the required range and accuracy to known values of input. The CHANNEL CALIBRATION shall encompass the entire channel including the required sensor, alarm, interlock, and/or trip functions and may be performed by any series of sequential, overlapping, or total channel steps, so that the entire channel is calibrated.

### CHANNEL CHECK

A CHANNEL CHECK shall be the qualitative assessment of channel behavior during operation by observation. This determination shall include, where possible, comparison of the channel indication and/or status with other indications and/or status derived from independent instrument channels measuring the same parameter.

### CHANNEL FUNCTIONAL TEST (CFT)

A CHANNEL FUNCTIONAL TEST shall be the injection of a simulated signal into the channel as close to the sensor as practicable to verify FUNCTIONALITY of required alarm, interlock, and/or trip functions. The CHANNEL FUNCTIONAL TEST shall include adjustments, as necessary, of the required alarm, interlock, and/or trip setpoints, so that the setpoints are within the required range and accuracy.

### DOSE EQUIVALENT I-131

DOSE EQUIVALENT I-131 shall be that concentration of I-131 ( $\mu\text{Ci/g}$ ) that alone would produce the same dose when inhaled as the combined activities of iodine isotopes I-131, I-132, I-133, I-134 and I-135 actually present. The determination of DOSE EQUIVALENT I-131 shall be performed using Committed Dose Equivalent (CDE) or Committed Effective Dose Equivalent (CEDE) dose conversion factor from Table 2.1 of EPA Federal Guidance Report No. 11.]

### MODE (or OPERATIONAL MODE)

An OPERATIONAL MODE shall correspond to any one inclusive combination of core reactivity condition, power level, average reactor coolant temperature, and reactor vessel head closure bolt tensioning specified in Section 1.0 of the Technical Specifications with fuel in the reactor vessel.

### FUNCTIONAL (or FUNCTIONALITY)

FUNCTIONALITY exists when a system, subsystem, train, component or device is capable of performing its specified function(s), and when all necessary attendant instrumentation, controls, electrical power, cooling or seal water, lubrication or other auxiliary equipment that are required for the system, subsystem, train, component or device to perform its function(s) are also capable of performing their related support function(s).

---

RATED THERMAL POWER

RATED THERMAL POWER shall be a total reactor core heat transfer rate to the reactor coolant of 3565 MWt.

THERMAL POWER

THERMAL POWER shall be the total reactor core heat transfer rate to the reactor coolant.

**Vogtle Electric Generating Plant – Units 1 and 2**  
**Annual Radioactive Effluent Release Report and**  
**Annual Non-Radiological Environmental Operating Report for 2025**

**Enclosure 3 to NL-26-0155**

**VEGP Units 1 and 2 Annual Non-Radiological Environmental Operating (2025)**

---

## VOGTLE ELECTRIC GENERATING PLANT - UNITS 1 AND 2

### **I. Introduction**

In accordance with Subsection 5.4.1 of the Vogtle Electric Generating Plant (VEGP) Environmental Protection Plan (Nonradiological), Appendix B to Facility Operating License Nos. NPF-68 and NPF-81, this report is submitted describing implementation of the Environmental Protection Plan for the calendar year 2025.

### **II. Reporting Requirements**

#### **A. Summaries and Analyses of Results of Environmental Protection Activities Required by Subsection 4.2 of the Environmental Protection Plan (EPP) for the Reporting Period**

1. Aquatic Monitoring - Liquid effluent monitoring was performed in accordance with State of Georgia National Pollutant Discharge Elimination System (NPDES) Permit GA0026786; there was no additional requirement for aquatic monitoring during the year.
2. Terrestrial Monitoring - Terrestrial monitoring is not required.
3. Maintenance of Transmission Line Corridors – There is no reporting requirement associated with this condition.
4. Noise Monitoring - There were no complaints reported regarding noise along the VEGP-related, high-voltage transmission lines.

#### **B. Comparison of the Year's Monitoring Activities with Preoperational Studies, Operational Controls, and Previous Monitoring Reports**

These programs were not required because no nonradiological environmental monitoring programs were conducted during the reporting period beyond those performed in accordance with NPDES Permit No. GA0026786 referenced in Section A above.

#### **C. Assessment of the Observed Impacts of Plant Operation on the Environment**

There were no significant adverse environmental impacts associated with plant operation during the year.

#### **D. EPP Noncompliance and Corrective Actions**

There were no EPP noncompliances during the year.

**E. Changes in Station Design or Operation, Tests, or Experiments Made in Accordance with EPP Subsection 3.1 Which Involved a Potentially Significant Unreviewed Environmental Question**

There were no changes in station design or operation, tests, or experiments which involved a potentially significant, unreviewed environmental question.

**F. Nonroutine Reports Submitted in Accordance with EPP Section 5.4.2**

There were no nonroutine reports submitted during the year.