

**PROPOSED APPENDIX A**

**TECHNICAL SPECIFICATIONS AND DESIGN FEATURES  
FOR THE MAGNASTOR SYSTEM**

**AMENDMENT NO. 7  
REVISION NO. 3**

**Appendix A  
Table of Contents**

1.0	USE AND APPLICATION .....	A1-1
1.1	Definitions .....	A1-1
1.2	Logical Connectors .....	A1-7
1.3	Completion Times .....	A1-9
1.4	Frequency .....	A1-13
2.0	[Reserved] .....	A2-1
3.0	LIMITING CONDITION FOR OPERATION (LCO) APPLICABILITY .....	A3-1
3.0	SURVEILLANCE REQUIREMENT (SR) APPLICABILITY .....	A3-2
3.1	MAGNASTOR SYSTEM Integrity .....	A3-3
3.1.1	Transportable Storage Canister (TSC) .....	A3-3
3.1.2	STORAGE CASK Heat Removal System .....	A3-9
3.2	MAGNASTOR SYSTEM Criticality Control for PWR Fuel .....	A3-10
3.2.1	Dissolved Boron Concentration .....	A3-10
3.3	MAGNASTOR SYSTEM Radiation Protection .....	A3-12
3.3.1	STORAGECASK Maximum Surface Dose Rate .....	A3-12
3.3.2	TSC Surface Contamination.....	A3-15
4.0	DESIGN FEATURES .....	A4-1
4.1	Design Features Significant to Safety .....	A4-1
4.1.1	Criticality Control .....	A4-1
4.1.2	Fuel Cladding Integrity .....	A4-1
4.1.3	Transfer Cask Shielding .....	A4-1
4.1.4	TSC Confinement Integrity .....	A4-2
4.2	Codes and Standards .....	A4-2
4.2.1	Alternatives to Codes, Standards, and Criteria .....	A4-3
4.2.2	Construction/Fabrication Alternatives to Codes, Standards, and Criteria .....	A4-3
4.3	Site-Specific Parameters and Analyses .....	A4-4
4.3.1	Design Basis Specific Parameters and Analyses .....	A4-4
4.4	TSC Handling and Transfer Facility .....	A4-5
5.0	ADMINISTRATIVE CONTROLS AND PROGRAMS .....	A5-1
5.1	Radioactive Effluent Control Program .....	A5-1
5.2	TSC Loading, Unloading, and Preparation Program .....	A5-1
5.3	Transport Evaluation Program .....	A5-2
5.4	ISFSI Operations Program .....	A5-2
5.5	Radiation Protection Program .....	A5-3
5.6	Special Requirements for the First System Placed in Service .....	A5-3
5.7	Training Program .....	A5-4
5.8	Pre-operational Testing and Training Exercises.....	A5-4

### List of Figures

Figure A3-1 STORAGE CASK Surface Dose Rate Measurement..... A3-14

### List of Tables

Table A3-1 Helium Mass per Unit Volume for MAGNASTOR TSCs ..... A3-8

Table A4-1 Load Combinations and Service Condition Definitions for the TSC Handling  
and Transfer Facility Structure ..... A4-7

1.0 USE AND APPLICATION

1.1 Definitions

NOTE

The defined terms of this section appear in capitalized type and are applicable throughout these Technical Specifications and Bases.

<u>Term</u>	<u>Definition</u>
ACTIONS	ACTIONS shall be that part of a Specification that prescribes Required Actions to be taken under designated Conditions within specified Completion Times.
ASSEMBLY AVERAGE FUEL ENRICHMENT	Value calculated by averaging the <sup>235</sup> U wt % enrichment over the entire fuel region (UO <sub>2</sub> ) of an individual fuel assembly, including axial blankets, if present.
BREACHED SPENT FUEL ROD	Spent fuel with cladding defects that permit the release of gas from the interior of the fuel rod. A fuel rod breach may be a minor defect (i.e., hairline crack or pinhole), allowing the rod to be classified as undamaged, or be a gross breach requiring a damaged fuel classification.
BURNUP	<p>a) Assembly Average Burnup: Value calculated by averaging the burnup over the entire fuel region (UO<sub>2</sub>) of an individual fuel assembly, including axial blankets, if present. Assembly average burnup represents the reactor record, nominal, value. The assembly average burnup is equal to the reactor record, nominal, energy production (MWd) over the life of the fuel assembly divided by the fuel assembly pre-irradiation heavy metal (U) mass in metric tons.</p> <p>b) Nonfuel Hardware Burnup: Equivalent accumulated irradiation exposure for activation evaluation.</p>
COMPOSITE CLOSURE LID	A closure lid assembly, consisting of a stainless steel TRANSPORTABLE STORAGE CANISTER closure lid and a separate shield plate bolted together, that provides closure of a TRANSPORTABLE STORAGE CANISTER.
CONCRETE CASK	The CONCRETE CASK is the vertical storage module that receives, holds and protects the sealed TSC for storage at the ISFSI. The CONCRETE CASK passively provides the radiation shielding, structural protection, and heat dissipation capabilities for the safe storage of spent fuel in a TSC. Closure for the CONCRETE CASK is provide by the CONCRETE CASK LID.

(continued)

---

CONCRETE CASK LID	The CONCRETE CASK LID is a thick concrete and steel closure for the CONCRETE CASK. The CONCRETE CASK LID precludes access to the TSC and provides radiation shielding.
DAMAGED FUEL	<p data-bbox="553 394 1373 493">SPENT NUCLEAR FUEL (SNF) assembly that cannot fulfill its fuel-specific or system-related function. SNF is classified as damaged under the following conditions.</p> <ol data-bbox="553 514 1373 1228" style="list-style-type: none"><li data-bbox="553 514 1373 682">1. There is visible deformation of the rods in the SNF assembly. Note: This is not referring to the uniform bowing that occurs in the reactor; this refers to bowing that significantly opens up the lattice spacing.</li><li data-bbox="553 703 1373 829">2. Individual fuel rods are missing from the SNF assembly and the missing rods are not replaced by a solid stainless steel or zirconium dummy rod that displaces a volume equal to, or greater than, the original fuel rod.</li><li data-bbox="553 850 1373 1228">3. The SNF assembly has missing, displaced or damaged structural components such that:<ol data-bbox="597 934 1373 1228" style="list-style-type: none"><li data-bbox="597 934 1373 997">3.1. Radiological and/or criticality safety is adversely affected (e.g., significantly changed rod pitch); or</li><li data-bbox="597 1018 1373 1081">3.2. The SNF assembly cannot be handled by normal means (i.e., crane and grapple); or</li><li data-bbox="597 1102 1373 1228">3.3. The PWR SNF assembly contains fuel rods with damaged or missing grids, grid straps, and/or grid springs producing an unsupported length greater than 60 inches.</li></ol>Note: PWR SNF assemblies with the following structural defects meet MAGNASTOR system-related functional requirements and are, therefore, classified as undamaged: Assemblies with missing or damaged grids, grid straps and/or grid springs resulting in an unsupported fuel rod length not to exceed 60 inches.</li></ol> <ol data-bbox="553 1459 1373 1934" style="list-style-type: none"><li data-bbox="553 1459 1373 1816">4. Any SNF assembly that contains fuel rods for which reactor operating records (or other records or tests) cannot support the conclusion that they do not contain gross breaches. Note: BREACHED SPENT FUEL RODs with minor cladding defects (i.e., pinhole leaks or hairline cracks that will not permit significant release of particulate matter from the spent fuel rod) meet MAGNASTOR system-related functional requirements and are, therefore, classified as undamaged.</li><li data-bbox="553 1837 1373 1934">5. FUEL DEBRIS such as ruptured fuel rods, severed rods, loose fuel pellets, containers or structures that are supporting loose PWR fuel assembly parts.</li></ol>

(continued)

DAMAGED FUEL CAN (DFC)	A specially designed stainless steel screened can sized to hold UNDAMAGED PWR FUEL, DAMAGED PWR FUEL, and/or FUEL DEBRIS. The screens preclude the release of gross particulate from the DFC into the canister cavity. DFCs are only authorized for loading in specified locations of a DF Basket Assembly.
FUEL DEBRIS	FUEL DEBRIS is ruptured fuel rods, severed rods, loose fuel pellets, containers or structures that are supporting loose PWR fuel assembly parts.
GROSSLY BREACHED SPENT FUEL ROD	A breach in the spent fuel cladding that is larger than a pinhole or hairline crack. A gross cladding breach may be established by visual examination with the capability to determine if the fuel pellet can be seen through the cladding, or through a review of reactor operating records indicating the presence of heavy metal isotopes.
INDEPENDENT SPENT FUEL STORAGE INSTALLATION (ISFSI)	The facility within the perimeter fence licensed for storage of spent fuel within MAGNASTOR SYSTEMS (see also 10 CFR 72.3).
INITIAL PEAK PLANAR-AVERAGE ENRICHMENT	The INITIAL PEAK PLANAR-AVERAGE ENRICHMENT is the maximum planar-average enrichment at any height along the axis of the fuel assembly. The INITIAL PEAK PLANAR-AVERAGE ENRICHMENT may be higher than the bundle (assembly) average enrichment.
LOADING OPERATIONS	LOADING OPERATIONS include all licensed activities while a MAGNASTOR SYSTEM is being loaded with fuel assemblies. LOADING OPERATIONS begin when the first assembly is placed in the TSC and end when the TSC is lowered into a CONCRETE CASK.
MAGNASTOR SYSTEM (MAGNASTOR)	The MAGNASTOR (Modular Advanced Generation Nuclear All-purpose STORAGE) SYSTEM includes the components certified for the storage of spent fuel assemblies at an ISFSI. The MAGNASTOR SYSTEM consists of a STORAGE CASK and a TSC. A MAGNASTOR TRANSFER CASK (MTC) or Passive MAGNASTOR TRANSFER CASK (PMTC) is provided and utilized to load and place a TSC in a CONCRETE CASK or to remove a TSC from a CONCRETE CASK.

(continued)

---

NONFUEL HARDWARE

NONFUEL HARDWARE is defined as reactor control components (RCCs), burnable poison absorber assemblies (BPAAs), guide tube plug devices (GTPDs), neutron sources/neutron source assemblies (NSAs), hafnium absorber assemblies (HFRAAs), instrument tube tie components, guide tube anchors or other similar devices, in-core instrument thimbles, steel rod inserts (used to displace water from lower section of guide tube), and components of these devices such as individual rods. All nonfuel hardware, with the exception of instrument tube tie components, guide tube anchors or other similar devices, and steel rod inserts, may be activated during in-core operations.

RCCs are commonly referred to as rod cluster control assemblies (RCCAs), control rod assemblies (CRAs), or control element assemblies (CEAs). RCCs are primarily designed to provide reactor shutdown reactivity control, are inserted into the guide tubes of the assembly, and are typically employed for a significant number of operating cycles. Burnup poison absorber assemblies (BPAAs) are commonly referred to as burnup poison rod assemblies (BPRAs), but may have vendor specific nomenclature such as BPRA, Pyrex BPRA or WABA (wet annular burnable absorber). BPAAs are used to control reactivity of fresh fuel or high reactivity fuels and are commonly used for a single cycle, but may be used for multiple cycles. GTPDs are designed to block guide tube openings when no BPAA is employed and are commonly referred to as thimble plugs (TPs), thimble plug devices (TPDs), flow mixers (FMs), water displacement guide tube plugs, or vibration suppressor inserts. GTPDs may be employed for multiple cycles. NSAs are primary and secondary neutron sources used during reactor startup and may be used for multiple cycles.

Integral fuel burnable absorbers, either integral to a fuel rod or as a substitution for a fuel rod, and fuel replacement rods (fueled, stainless steel, or zirconium alloy) are considered components of spent nuclear fuel (SNF) assemblies and are not considered to be nonfuel hardware.

OPERABLE

A system, component, or device is OPERABLE when it is capable of performing its specified safety functions.

---

(continued)

---

SPENT NUCLEAR FUEL (SNF)	Irradiated fuel assemblies consisting of end-fittings, grids, fuel rods and integral hardware. Integral hardware for PWR assemblies primarily consists of guide/instrument tubes, but may contain integral fuel burnable absorbers, either integral to a fuel rod or as a fuel rod substitution, and fuel replacement rods (another fuel rod, stainless steel rod, or zirconium alloy rod). For BWR fuel, integral hardware may consist of water rods in various shapes, inert rods, fuel rod cluster dividers, and/or fuel assembly channels (optional). PWR SNF may contain NONFUEL HARDWARE.
STORAGE CASK	A STORAGE CASK is a CONCRETE CASK with a CONCRETE CASK LID.
STORAGE OPERATIONS	STORAGE OPERATIONS include all licensed activities that are performed at the ISFSI following placement of a STORAGE CASK containing a loaded TSC at its designated storage location on the storage pad.
TRANSFER CASK	TRANSFER CASK is a shielded lifting device designed to hold the TSC during LOADING OPERATIONS, TRANSFER OPERATIONS, and UNLOADING OPERATIONS. Either a MAGNASTOR TRANSFER CASK (MTC) or Passive MAGNASTOR TRANSFER CASK (PMTC) may be used.
TRANSFER OPERATIONS	TRANSFER OPERATIONS include all licensed activities involved in using a MAGNASTOR TRANSFER CASK (MTC) or Passive MAGNASTOR TRANSFER CASK (PMTC) to move a loaded and sealed TSC from a CONCRETE CASK to another CONCRETE CASK.
TRANSPORT OPERATIONS	TRANSPORT OPERATIONS include all licensed activities performed on a loaded MAGNASTOR STORAGE CASK when it is being moved to and from its designated location on the ISFSI. TRANSPORT OPERATIONS begin when the loaded STORAGE CASK is placed on or lifted by a transporter and end when the STORAGE CASK is set down in its storage position on the ISFSI pad.
TRANSPORTABLE STORAGE CANISTER (TSC)	The TRANSPORTABLE STORAGE CANISTER (TSC) is the welded container consisting of a basket in a weldment composed of a cylindrical shell welded to a baseplate. The TSC includes a closure lid, a shield plate (optional), a closure ring, and redundant port covers at the vent and the drain ports. The closure lid is welded to the TSC shell and the closure ring is welded to the closure lid and the TSC shell. The port covers are welded to the closure lid. The TSC provides the confinement boundary for the radioactive material contained in the TSC cavity.

---

(continued)

---

TSC TRANSFER FACILITY	The TSC TRANSFER FACILITY includes: 1) a transfer location for the lifting and transfer of a TRANSFER CASK and placement of a TSC into or out of a CONCRETE CASK; and 2) either a stationary lift device or a mobile lifting device used to lift the TRANSFER CASK and TSC, but not licensed as part of the 10 CFR Part 50 facility.
UNDAMAGED FUEL	SNF that can meet all fuel specific and system-related functions. UNDAMAGED FUEL is SNF that is not DAMAGED FUEL, as defined herein, and does not contain assembly structural defects that adversely affect radiological and/or criticality safety. As such, UNDAMAGED FUEL may contain: <ul style="list-style-type: none"><li>a) BREACHED SPENT FUEL RODS (i.e., rods with minor defects up to hairline cracks or pinholes) but cannot contain grossly breached fuel rods;</li><li>b) For PWR SNF: Grid, grid strap, and/or grid spring damage provided that the unsupported length of the fuel rod does not exceed 60 inches.</li></ul>
UNLOADING OPERATIONS	UNLOADING OPERATIONS include the activities required to remove the fuel assemblies from a sealed TSC. UNLOADING OPERATIONS begin with the movement of the TSC from a CONCRETE CASK into a TRANSFER CASK in an unloading facility and end when the last fuel assembly has been removed from the TSC.

---

1.0 USE AND APPLICATION

1.2 Logical Connectors

---

**PURPOSE** The purpose of this section is to explain the meaning of logical connectors.

Logical connectors are used in Technical Specifications (TS) to discriminate between, and yet connect, discrete Conditions, Required Actions, Completion Times, Surveillances, and Frequencies. The only logical connectors that appear in Technical Specifications are “AND” and “OR”. The physical arrangement of these connectors constitutes logical conventions with specific meanings.

**BACKGROUND** Several levels of logic may be used to state Required Actions. These levels are identified by the placement (or nesting) of the logical connectors and by the number assigned to each Required Action. The first level of logic is identified by the first digit of the number assigned to a Required Action and the placement of the logical connector in the first level of nesting (i.e., left justified with the number of the Required Action). The successive levels of logic are identified by additional digits of the Required Action number and by successive indentations of the logical connectors.

When logical connectors are used to state a Condition, Completion Time, Surveillance, or Frequency, only the first level of logic is used, and the logical connector is left justified with the statement of the Condition, Completion Time, Surveillance, or Frequency.

**EXAMPLES** The following examples illustrate the use of logical connectors.

EXAMPLE 1.2-1

ACTIONS

CONDITION		REQUIRED ACTION	COMPLETION TIME
A.	LCO not met	A.1 Verify . . .	
		<u>AND</u>	
		A.2 Restore . . .	

In this example, the logical connector “AND” is used to indicate that when in Condition A, both Required Actions A.1 and A.2 must be completed.

(continued)

EXAMPLES  
(continued)

EXAMPLE 1.2-2

ACTIONS

CONDITION	REQUIRED ACTION	COMPLETION TIME
A. LCO not met	A.1 Stop . . . <u>OR</u> A.2.1 Verify . . . <u>AND</u> A.2.2 A.2.2.1 Reduce . . . <u>OR</u> A.2.2.2 Perform . . . <u>OR</u> A.3 Remove . . .	

This example represents a more complicated use of logical connectors. Required Actions A.1, A.2, and A.3 are alternative choices, only one of which must be performed as indicated by the use of the logical connector “OR” and the left justified placement. Any one of these three Actions may be chosen. If A.2 is chosen, then both A.2.1 and A.2.2 must be performed as indicated by the logical connector “AND”. Required Action A.2.2 is met by performing A.2.2.1 or A.2.2.2. The indented position of the logical connector “OR” indicates that A.2.2.1 and A.2.2.2 are alternative choices, only one of which must be performed.

1.0 USE AND APPLICATION

1.3 Completion Times

---

**PURPOSE** The purpose of this section is to establish the Completion Time convention and to provide guidance for its use.

---

**BACKGROUND** Limiting Conditions for Operation (LCOs) specify the lowest functional capability or performance levels of equipment required for safe operation of the facility. The ACTIONS associated with an LCO state conditions that typically describe the ways in which the requirements of the LCO can fail to be met. Specified with each stated Condition are Required Action(s) and Completion Time(s).

---

**DESCRIPTION** The Completion Time is the amount of time allowed for completing a Required Action. It is referenced to the time of discovery of a situation (e.g., equipment or variable not within limits) that requires entering an ACTIONS Condition unless otherwise specified, provided that MAGNASTOR is in a specified condition stated in the Applicability of the LCO. Required Actions must be completed prior to the expiration of the specified Completion Time. An ACTIONS Condition remains in effect and the Required Actions apply until the Condition no longer exists or MAGNASTOR is not within the LCO Applicability.

Once a Condition has been entered, subsequent subsystems, components, or variables expressed in the Condition, discovered to be not within limits, will not result in separate entry into the Condition unless specifically stated. The Required Actions of the Condition continue to apply to each additional failure, with Completion Times based on initial entry into the Condition.

---

(continued)

EXAMPLES

The following examples illustrate the use of Completion Times with different types of Conditions and changing Conditions.

EXAMPLE 1.3-1

ACTIONS

CONDITION	REQUIRED ACTION	COMPLETION TIME
B. Required Action and associated Completion Time not met	B.1 Perform Action B.1	12 hours
	<u>AND</u> B.2 Perform Action B.2	36 hours

Condition B has two Required Actions. Each Required Action has its own Completion Time. Each Completion Time is referenced to the time that Condition B is entered.

The Required Actions of Condition B are to complete action B.1 within 12 hours AND complete action B.2 within 36 hours. A total of 12 hours is allowed for completing action B.1 and a total of 36 hours (not 48 hours) is allowed for completing action B.2 from the time that Condition B was entered. If action B.1 is completed within six hours, the time allowed for completing action B.2 is the next 30 hours because the total time allowed for completing action B.2 is 36 hours.

(continued)

EXAMPLES  
(continued)

EXAMPLE 1.3-2  
ACTIONS

CONDITION	REQUIRED ACTION	COMPLETION TIME
A. One system not within limit.	A.1 Restore system to within limit.	7 days
B. Required Action and associated Completion Time not met.	B.1 Complete action B.1	12 hours
	<u>AND</u> B.2 Complete action B.2	36 hours

When a system is determined not to meet the LCO, Condition A is entered. If the system is not restored within 7 days, Condition B is also entered, and the Completion Time clocks for Required Actions B.1 and B.2 start. If the system is restored after Condition B is entered, Conditions A and B are exited, and therefore, the Required Actions of Condition B may be terminated.

(continued)

EXAMPLES  
(continued)

EXAMPLE 1.3-3  
ACTIONS

NOTE  
Separate Condition entry is allowed for each component.

CONDITION	REQUIRED ACTION	COMPLETION TIME
A. LCO not met	A.1 Restore compliance with LCO.	4 hours
B. Required Action and associated Completion Time not met.	B.1 Complete action B.1	6 hours
	<u>AND</u> B.2 Complete action B.2	12 hours

The Note above the ACTIONS table is a method of modifying how the Completion Time is tracked. If this method of modifying how the Completion Time is tracked was applicable only to a specific Condition, the Note would appear in that Condition rather than at the top of the ACTIONS Table.

The Note allows Condition A to be entered separately for each component, and Completion Times to be tracked on a per component basis. When a component is determined to not meet the LCO, Condition A is entered and its Completion Time starts. If subsequent components are determined to not meet the LCO, Condition A is entered for each component and separate Completion Times are tracked for each component.

IMMEDIATE  
COMPLETION TIME

When “Immediately” is used as a Completion Time, the Required Action should be pursued without delay and in a controlled manner.

1.0 USE AND APPLICATION

1.4 Frequency

---

**PURPOSE** The purpose of this section is to define the proper use and application of Frequency requirements.

---

**DESCRIPTION** Each Surveillance Requirement (SR) has a specified Frequency in which the Surveillance must be met in order to meet the associated Limiting Condition for Operation (LCO). An understanding of the correct application of the specified Frequency is necessary for compliance with the SR.

Each “specified Frequency” is referred to throughout this section and each of the Specifications of Section 3.0, Surveillance Requirement (SR) Applicability. The “specified Frequency” consists of requirements of the Frequency column of each SR.

Situations where a Surveillance could be required (i.e., its Frequency could expire), but where it is not possible or not desired that it be performed until sometime after the associated LCO is within its Applicability, represent potential SR 3.0.4 conflicts. To avoid these conflicts, the SR (i.e., the Surveillance or the Frequency) is stated such that it is only “required” when it can be and should be performed. With an SR satisfied, SR 3.0.4 imposes no restriction.

The use of “met” or “performed” in these instances conveys specific meanings. Surveillance is “met” only after the acceptance criteria are satisfied. Known failure of the requirements of Surveillance, even without Surveillance specifically being “performed”, constitutes a Surveillance not “met”.

---

(continued)

EXAMPLES

The following examples illustrate the various ways that Frequencies are specified.

EXAMPLE 1.4-1

SURVEILLANCE REQUIREMENTS

SURVEILLANCE	FREQUENCY
Verify pressure within limit	12 hours

Example 1.4-1 contains the type of SR most often encountered in the Technical Specifications (TS). The Frequency specifies an interval (12 hours) during which the associated Surveillance must be performed at least one time. Performance of the Surveillance initiates the subsequent interval. Although the Frequency is stated as 12 hours, an extension of the time interval to 1.25 times the interval specified in the Frequency is allowed by SR 3.0.2 for operational flexibility. The measurement of this interval continues at all times, even when the SR is not required to be met per SR 3.0.1 (such as when the equipment or variables are outside specified limits, or the facility is outside the Applicability of the LCO). If the interval specified by SR 3.0.2 is exceeded while the facility is in a condition specified in the Applicability of the LCO, the LCO is not met in accordance with SR 3.0.1.

If the interval as specified by SR 3.0.2 is exceeded while the facility is not in a condition specified in the Applicability of the LCO for which performance of the SR is required, the Surveillance must be performed within the Frequency requirements of SR 3.0.2, prior to entry into the specified condition. Failure to do so would result in a violation of SR 3.0.4.

(continued)

EXAMPLES

(continued)

EXAMPLE 1.4-2

SURVEILLANCE REQUIREMENTS

SURVEILLANCE	FREQUENCY
Verify flow is within limit	Once within 12 hours prior to starting activity  <u>AND</u> 24 hours thereafter

Example 1.4-2 has two Frequencies. The first is a one-time performance Frequency, and the second is of the type shown in Example 1.4-1. The logical connector “AND” indicates that both Frequency requirements must be met. Each time the example activity is to be performed, the Surveillance must be performed within 12 hours prior to starting the activity.

The use of “once” indicates a single performance will satisfy the specified Frequency (assuming no other Frequencies are connected by “AND”). This type of Frequency does not qualify for the 25% extension allowed by SR 3.0.2.

“Thereafter” indicates future performances must be established per SR 3.0.2, but only after a specified condition is first met (i.e., the “once” performance in this example). If the specified activity is canceled or not performed, the measurement of both intervals stops. New intervals start upon preparing to restart the specified activity.

2.0 [Reserved]

3.0 LIMITING CONDITION FOR OPERATION (LCO) APPLICABILITY

---

LCO 3.0.1	LCOs shall be met during specified conditions in the Applicability, except as provided in LCO 3.0.2.
LCO 3.0.2	<p>Upon failure to meet an LCO, the Required Actions of the associated Conditions shall be met, except as provided in LCO 3.0.5.</p> <p>If the LCO is met or is no longer applicable prior to expiration of the specified Completion Time(s), completion of the Required Action(s) is not required, unless otherwise stated.</p>
LCO 3.0.3	Not applicable to MAGNASTOR.
LCO 3.0.4	<p>When an LCO is not met, entry into a specified condition in the Applicability shall not be made except when the associated ACTIONS to be entered permit continued operation in the specified condition in the Applicability for an unlimited period of time. This Specification shall not prevent changes in specified conditions in the Applicability that are required to comply with ACTIONS or that are related to the unloading of MAGNASTOR.</p> <p>Exceptions to this Condition are stated in the individual Specifications. These exceptions allow entry into specified conditions in the Applicability where the associated ACTIONS to be entered allow operation in the specified conditions in the Applicability only for a limited period of time.</p>
LCO 3.0.5	This exception to LCO 3.0.2 is not applicable for the MAGNASTOR SYSTEM to return to service under administrative control to perform the testing.

---

3.0 SURVEILLANCE REQUIREMENT (SR) APPLICABILITY

---

SR 3.0.1 SRs shall be met during the specified conditions in the Applicability for individual LCOs, unless otherwise stated in the SR. Failure to meet Surveillance, whether such failure is experienced during the performance of the Surveillance or between performances of the Surveillance, shall be a failure to meet the LCO. Failure to perform Surveillance within the specified Frequency shall be a failure to meet the LCO, except as provided in SR 3.0.3. Surveillances do not have to be performed on equipment or variables outside specified limits.

---

SR 3.0.2 The specified Frequency for each SR is met if the Surveillance is performed within 1.25 times the interval specified in the Frequency, as measured from the previous performance or as measured from the time a specified condition of the Frequency is met.

For Frequencies specified as “once,” the above interval extension does not apply. If a Completion Time requires periodic performance on a “once per...” basis, the above Frequency extension applies to each performance after the initial performance.

Exceptions to this Specification are stated in the individual Specifications.

---

SR 3.0.3 If it is discovered that Surveillance was not performed within its specified Frequency, then compliance with the requirement to declare the LCO not met may be delayed from the time of discovery up to 24 hours or up to the limit of the specified Frequency, whichever is less. This delay period is permitted to allow performance of the Surveillance.

If the Surveillance is not performed within the delay period, the LCO must immediately be declared not met, and the applicable Condition(s) must be entered. When the Surveillance is performed within the delay period and the Surveillance is not met, the LCO must immediately be declared not met, and the applicable Condition(s) must be entered.

---

SR 3.0.4 Entry into a specified Condition in the Applicability of an LCO shall not be made, unless the LCO’s Surveillances have been met within their specified Frequency. This provision shall not prevent entry into specified conditions in the Applicability that are required to comply with Actions or that are related to the unloading of MAGNASTOR.

---

3.1 MAGNASTOR SYSTEM Integrity

---

3.1.1 Transportable Storage Canister (TSC)

---

LCO 3.1.1

The TSC shall be dry and helium filled. The following vacuum drying times, helium backfill and TSC transfer times shall be met as appropriate to the fuel content type and heat load:

1. The time durations covering the beginning of canister draining through completion of vacuum drying and helium backfill, minimum helium backfill times, and TSC transfer times shall meet the following:

**A. PWR TSC Transfer Using MTC Reduced Helium Backfill Time**

Heat Load (kW)	Maximum Vacuum Time Limit (hours)	Minimum Helium Backfill Time (hours)	Maximum TSC Transfer Time (hours)
≤ 20	No limit	0	600
≤ 25	50	7	70.5
≤ 30	19	7	8
≤ 35.5	15	7	8

**B. PWR Using MTC with Maximum TSC Transfer**

Heat Load (kW)	Maximum Vacuum Time Limit (hours)	Minimum Helium Backfill Time (hours)	Maximum TSC Transfer Time (hours)
≤ 25	No limit	24	48
≤ 30	32	24	22
≤ 35.5	24	24	22

**C. BWR Using MTC with 8 Hours TSC Transfer**

Heat Load (kW)	Maximum Vacuum Time Limit (hours)	Minimum Helium Backfill Time (hours)	Maximum TSC Transfer Time (hours)
≤ 25	No limit	0	8
≤ 29	34	6	8
≤ 30	31	6	8
≤ 33	26	6	8

(continued)

**D. BWR Using MTC with Maximum TSC Transfer**

Heat Load (kW)	Maximum Vacuum Time Limit (hours)	Minimum Helium Backfill Time (hours)	Maximum TSC Transfer Time (hours)
≤ 25	No limit	24	65
≤ 29	No limit	24	32
≤ 30	44	24	32
≤ 33	33	24	32

**E. PWR TSC Transfer Using PMTC<sup>1</sup>**

Heat Load (kW)	Maximum Vacuum Time Limit (hours)	Minimum Helium Backfill Time (hours)	Maximum TSC Transfer Time (hours)
≤ 20	No limit	0	600
≤ 25	54	0	600
≤ 30	32	0	600

2. The time duration from the end of TSC annulus cooling, either by 24 hours in the pool or by the annulus circulating water system, through completion of vacuum drying and helium backfill using a MTC shall not exceed the following:

	Heat Load	Time Limit (hours)
PWR	35.5	11
BWR	33	16

Note: The helium backfill times and TSC transfer times provided in Tables 1.B and 1.D shall be used for operations following the second or subsequent vacuum drying cycles using the MTC.

(continued)

<sup>1</sup> CE 16 × 16 fuel only, with a maximum storage cell location heat load of 811 watts.

3. The time duration from the end of TSC annulus cooling, either by 24 hours in the pool or by the annulus circulating water system, through completion of vacuum drying and helium backfill using a PMTC shall not exceed the following:

	<b>Heat Load</b>	<b>Time Limit (hours)</b>
PWR	$\leq 25$	34
PWR	$\leq 30$	17

Note: The helium backfill times and TSC transfer times provided in Table 1.E shall be used for operations following the second or subsequent vacuum drying cycles using the PMTC.

APPLICABILITY: Prior to TRANSPORT OPERATIONS

---

(continued)

ACTIONS

NOTE

Separate Condition entry is allowed for each TSC.

CONDITION	REQUIRED ACTION	COMPLETION TIME
A. TSC cavity vacuum drying pressure limit not met.	A.1 Perform an engineering evaluation to determine the quantity of moisture remaining in the TSC.	7 days
	<u>AND</u> A.2 Develop and initiate corrective actions necessary to return the TSC to an analyzed condition.	30 days
B. TSC helium backfill density limit not met.	B.1 Perform an engineering evaluation to determine the effect of helium density differential.	72 hours
	<u>AND</u> B.2 Develop and initiate corrective actions necessary to return the TSC to an analyzed condition.	14 days
C. Required Actions and associated Completion Times not met.	C.1 Remove all fuel assemblies from the TSC.	30 days

(continued)

SURVEILLANCE REQUIREMENTS		
SURVEILLANCE		FREQUENCY
SR 3.1.1.1	Verify TSC cavity vacuum drying pressure is less than or equal to 10 torr for greater than or equal to 10 minutes with the vacuum pump turned off and isolated.	Once, prior to TRANSPORT OPERATIONS.
SR 3.1.1.2	Following vacuum drying and evacuation to < 3 torr, backfill the cavity with high purity helium until a mass $M_{\text{helium}}$ corresponding to the free volume of the TSC measured during draining ( $V_{\text{TSC}}$ ), multiplied by the helium density ( $L_{\text{helium}}$ ) required for the design basis heat load and specified in Table A3-1, is reached.	Once, prior to TRANSPORT OPERATIONS.

**Table A3-1 Helium Mass per Unit Volume for MAGNASTOR TSCs**

<b>Fuel Type</b>	<b>Helium Density (g/liter)</b>
PWR	0.694 – 0.802
BWR	0.704 – 0.814



3.2 MAGNASTOR SYSTEM Criticality Control for PWR Fuel

3.2.1 Dissolved Boron Concentration

LCO 3.2.1 The dissolved boron concentration in the water in the TSC cavity shall be greater than, or equal to, the concentration specified in Appendix B, Table B2-4. A minimum concentration of 1,500 ppm is required for all PWR fuel types. Higher concentrations are required, depending on the fuel type and enrichment.

APPLICABILITY: During LOADING OPERATIONS and UNLOADING OPERATIONS with water and at least one fuel assembly in the TSC.

ACTIONS

NOTE

Separate Condition entry is allowed for each TSC.

CONDITION	REQUIRED ACTION	COMPLETION TIME
A. Dissolved boron concentration not met.	A.1 Suspend LOADING OPERATIONS or UNLOADING OPERATIONS  <u>AND</u>	Immediately
	A.2 Suspend positive reactivity additions.  <u>AND</u>	Immediately
	A.3 Initiate action to restore boron concentration to within limits.	Immediately

(continued)

---

---

SURVEILLANCE REQUIREMENTS

---

SURVEILLANCE	FREQUENCY
SR 3.2.1.1      Verify the dissolved boron concentration is met using two independent measurements.	Once within 4 hours prior to commencing LOADING OPERATIONS or UNLOADING OPERATIONS.  <u>AND</u> Every 24 hours thereafter while the TSC is in the spent fuel pool or while water is in the TSC.

---

3.3 MAGNASTOR SYSTEM Radiation Protection

---

3.3.1 STORAGE CASK Maximum Surface Dose Rate

---

- LCO 3.3.1 The maximum surface dose rates for the STORAGE CASK, Reference Figure A3-1, shall not exceed the following limits:
- a. PWR and BWR – 120 mrem/hour gamma and 5 mrem/hour neutron on the vertical concrete surfaces; and
  - b. PWR and BWR – 450 mrem/hour (neutron + gamma) on the top.

APPLICABILITY: Prior to start of STORAGE OPERATIONS

ACTIONS

-----NOTE-----

Separate Condition entry is allowed for each MAGNASTOR® SYSTEM.

CONDITION	REQUIRED ACTION	COMPLETION TIME
A. STORAGE CASK maximum surface dose rate limits not met	A.1 Administratively verify correct fuel loading	24 hours
	<u>AND</u> A.2 Perform analysis to verify compliance with the ISFSI radiation protection requirements of 10 CFR Part 20 and 10 CFR Part 72	7 days
B. Required Action and associated Completion Time not met	B.1 Perform (and document) an engineering assessment and take appropriate corrective action to ensure the dose limits of 10 CFR Part 20 and 10 CFR Part 72 are not exceeded	60 days

(continued)

---

SURVEILLANCE REQUIREMENTS

---

SURVEILLANCE	FREQUENCY
SR 3.3.1.1      Verify maximum surface dose rates of STORAGE CASK loaded with a TSC containing fuel assemblies are within limits. Dose rates shall be measured at the locations shown in Figure A3-1.	Prior to start of STORAGE OPERATIONS of each loaded STORAGE CASK before or after placement on the ISFSI pad.

---

**Figure A3-1 STORAGE CASK Surface Dose Rate Measurement**

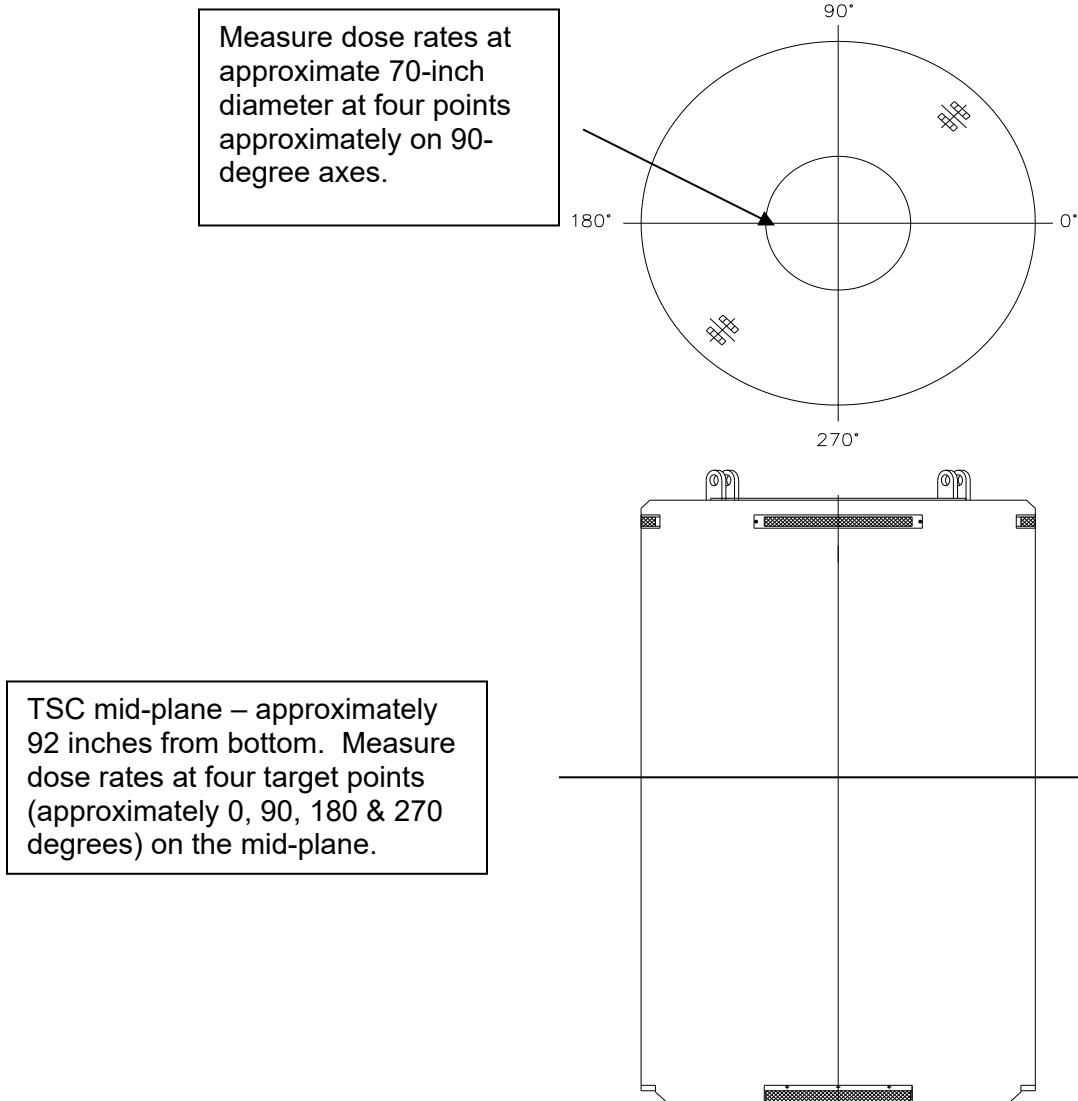

3.3 MAGNASTOR SYSTEM Radiation Protection

3.3.2 TSC Surface Contamination

LCO 3.3.2 Removable contamination on the exterior surfaces of the TSC shall not exceed:

- a. 10,000 dpm/100 cm<sup>2</sup> from beta and gamma sources; and
- b. 100 dpm/100 cm<sup>2</sup> from alpha sources.

APPLICABILITY: During LOADING OPERATIONS

ACTIONS

-----NOTE-----  
Separate Condition entry is allowed for each MAGNASTOR SYSTEM.  
-----

CONDITION	REQUIRED ACTION	COMPLETION TIME
A. TSC removable surface contamination limits not met	A.1 Restore TSC removable surface contamination to within limits	Prior to TRANSPORT OPERATIONS

(continued)

SURVEILLANCE REQUIREMENTS		
	SURVEILLANCE	FREQUENCY
SR 3.3.2	Verify by either direct or indirect methods that the removable contamination on the exterior surfaces of the TSC is within limits	Once, prior to TRANSPORT OPERATIONS

4.0 DESIGN FEATURES

4.1 Design Features Significant to Safety

4.1.1 Criticality Control

a) Minimum <sup>10</sup>B loading in the neutron absorber material:

Neutron Absorber Type	Required Minimum Effective Areal Density ( <sup>10</sup> B g/cm <sup>2</sup> )		% Credit Used in Criticality Analyses	Required Minimum Actual Areal Density ( <sup>10</sup> B g/cm <sup>2</sup> )	
	PWR Fuel	BWR Fuel		PWR Fuel	BWR Fuel
Borated Aluminum Alloy	0.036	0.027	90	0.04	0.03
	0.030	0.0225		0.0334	0.025
	0.027	0.020		0.03	0.0223
Borated MMC	0.036	0.027	90	0.04	0.03
	0.030	0.0225		0.0334	0.025
	0.027	0.020		0.03	0.0223
Boral	0.036	0.027	75	0.048	0.036
	0.030	0.0225		0.04	0.030
	0.027	0.020		0.036	0.0267

Enrichment/soluble boron limits for PWR systems and enrichment limits for BWR systems are incorporated in Appendix B Section 2.0.

b) Acceptance and qualification testing of borated aluminum alloy and borated MMC neutron absorber material shall be in accordance with Sections 10.1.6.4.5, 10.1.6.4.6 and 10.1.6.4.7. Acceptance testing of Boral shall be in accordance with Section 10.1.6.4.8. These sections of the FSAR are hereby incorporated into the MAGNASTOR CoC.

c) Soluble boron concentration in the PWR fuel pool and water in the TSC shall be in accordance with LCO 3.2.1, with a minimum water temperature 5-10°F higher than the minimum needed to ensure solubility.

d) Minimum fuel tube outer diagonal dimension

PWR basket — 13.08 inches

BWR basket — 8.72 inches

Note: Not applicable to DFC locations of the DF Basket Assembly.

4.1.2 Fuel Cladding Integrity

The licensee shall ensure that fuel oxidation and the resultant consequences are precluded during canister loading and unloading operations.

4.1.3 Transfer Cask Shielding

The nominal configuration transfer cask radial bulk shielding (i.e., shielding integral to the transfer cask; excludes supplemental shielding) must provide a

(continued)

minimum radiation shield equivalent to 2 inches of carbon steel or stainless steel and 3.2 inches of lead gamma shielding and 2.25 inches of NS-4-FR (with 0.6 wt % B<sub>4</sub>C and 6.0 wt % H) neutron shielding. Material and dimensions of the individual shield layers may vary provided maximum calculated radial dose rates of 1100 mrem/hr (PWR system) and 1600 mrem/hr (BWR system) are maintained on the vertical surface (not including doors or vent shielding).

---

#### 4.1.4 TSC Confinement Integrity

---

The TSC shell, bottom plate, all confinement welds, and the COMPOSITE CLOSURE LID shall be fabrication helium leak-tested in accordance with ANSI N14.5 to leaktight criterion.

The closure lid shall be helium leak-tested during fabrication (in accordance with ANSI N14.5 to leaktight criterion) if it is constructed with a lid thickness less than 9 inches (nominal).

---

#### 4.2 Codes and Standards

---

The American Society of Mechanical Engineers Boiler and Pressure Vessel Code (ASME Code), 2001 Edition with Addenda through 2003, Section III, Subsection NB, is the governing Code for the design, material procurement, fabrication, and testing of the TSC.

The ASME Code, 2001 Edition with Addenda through 2003, Section III, Subsection NG, is the governing Code for the design, material procurement, fabrication and testing of the spent fuel baskets.

The American Concrete Institute Specifications ACI-349 and ACI-318 govern the CONCRETE CASK design and construction, respectively.

The concrete used in the construction of the CONCRETE CASK LID, at minimum, shall be of a commercial grade ready-mix type that can develop a density of 140 pcf. The mix and batching should meet the purchaser's requirement of unit weight (i.e., density) and any additional purchaser indicated attributes (e.g., air content), as allowed by ASTM C94.

The unit weight (i.e., density) of the concrete in the CONCRETE CASK LID can be verified by either test method ASTM C138 or an approved shop fabrication procedure by following the basic equation of  $\rho=W/V$ . The shop procedure shall include steps to weigh the lid before and after concrete placement and in calculating the actual volume (V) of the cavity to be filled with a record of the weight (W) of concrete placed into the cavity.

The CONCRETE CASK LID concrete placement shall be in a dry and clean cavity or form with procedures and equipment that ensure the concrete placed is thoroughly consolidated and worked around any reinforcement and/or embedded fixtures and into the corners of the cavity or form.

The CONCRETE CASK LID concrete shall be protected from the environment during curing to minimize development of cracks by one or more of various methods such as moist cure or liquid membrane forming chemicals. Type II Portland cement may be substituted by an alternate cement type for the CONCRETE CASK LID if the density requirement can be met.

The American National Standards Institute ANSI N14.6 (1993) and NUREG-0612 govern the TRANSFER CASK design, operation, fabrication, testing, inspection, and maintenance.

4.2.1 Alternatives to Codes, Standards, and Criteria

---

Table 2.1-2 of the FSAR lists approved alternatives to the ASME Code for the design, procurement, fabrication, inspection and testing of MAGNASTOR SYSTEM TSCs and spent fuel baskets.

4.2.2 Construction/Fabrication Alternatives to Codes, Standards, and Criteria

---

Proposed alternatives to ASME Code, Section III, 2001 Edition with Addenda through 2003, other than the alternatives listed in Table 2.1-2 of the FSAR, may be used when authorized by the Director of the Office of Nuclear Material Safety and Safeguards or designee. The request for such alternatives should demonstrate that:

1. The proposed alternatives would provide an acceptable level of quality and safety, or
2. Compliance with the specified requirements of ASME Code, Section III, Subsections NB and NG, 2001 Edition with Addenda through 2003, would result in hardship or unusual difficulty without a compensating increase in the level of quality and safety.

Requests for alternatives shall be submitted in accordance with 10 CFR 72.4.

---

(continued)

---

4.3 Site-Specific Parameters and Analyses

---

This section presents site-specific parameters and analytical bases that must be verified by the MAGNASTOR SYSTEM user. The parameters and bases presented in Section 4.3.1 are those applied in the design bases analysis.

4.3.1 Design Basis Specific Parameters and Analyses

---

The design basis site-specific parameters and analyses that require verification by the MAGNASTOR SYSTEM user are:

- a. A temperature of 76°F is the maximum average yearly temperature. The three-day average ambient temperature shall be  $\leq 106^{\circ}\text{F}$ .
- b. The allowed temperature extremes, averaged over a three-day period, shall be  $\geq -40^{\circ}\text{F}$  and  $\leq 133^{\circ}\text{F}$ .
- c. The analyzed flood condition of 15 fps water velocity and a depth of 50 ft of water (full submergence of the loaded cask) are not exceeded.
- d. The potential for fire and explosion shall be addressed, based on site-specific considerations. This includes the condition that the fuel tank(s) of the cask handling equipment used to move the loaded STORAGE CASK onto or from the ISFSI site contains a total of no more than 50 gallons of fuel.
- e. In cases where engineered features (i.e., berms, shield walls) are used to ensure that requirements of 10 CFR 72.104(a) are met, such features are to be considered important to safety and must be evaluated to determine the applicable Quality Assurance Category on a site-specific basis.
- f. The TRANSFER CASK shall not be operated and used when surrounding air temperature is  $< 0^{\circ}\text{F}$ . This limit is NOT applicable to the stainless steel MTC or PMTC.
- g. The STORAGE CASK shall not be lifted by the lifting lugs with surrounding air temperatures  $< 0^{\circ}\text{F}$ .
- h. Loaded STORAGE CASK lifting height limit  $\leq 24$  inches.

---

(continued)

- i. The maximum design basis earthquake acceleration of 0.37g in the horizontal direction (without cask sliding) and 0.25g in the vertical direction at the ISFSI pad top surface do not result in cask tip-over.

For design basis earthquake accelerations up to and greater than 0.37g in the horizontal direction and 0.25g in the vertical direction at the ISFSI pad top surface, site-specific cask sliding is permitted with validation by the cask user that the cask does not slide off the pad and that the g-load resulting from the collision of two sliding casks remains bounded by the cask tip-over accident condition analysis presented in Chapter 3 of the FSAR.

An alternative to crediting site-specific cask sliding for design basis earthquake accelerations up to and greater than 0.37g in the horizontal direction and 0.25g in the vertical direction at the ISFSI pad top surface, the use of the MAGNASTOR system is permitted provided the ISFSI pad has bollards and the cask user validates that the cask does not overturn, g-loads resulting from the cask contacting the bollard is bounded by the cask tip-over accident condition presented in Chapter 3 of the FSAR, and the ISFSI pad and bollards are designed, fabricated and installed such that they are capable of handling the combined loading of the design basis earthquake and any contact between the bollard and cask during the design basis earthquake.

#### 4.4 TSC Handling and Transfer Facility

---

The TSC provides a leaktight confinement boundary and is evaluated for normal and off-normal handling loads. A handling and transfer facility is not required for TSC and TRANSFER CASK handling and transfer operations within a 10 CFR Part 50 licensed facility or for utilizing an external crane structure integral to a 10 CFR Part 50 licensed facility.

Movements of the TRANSFER CASK and TSC outside of a 10 CFR Part 50 licensed facility are not permitted unless a TSC TRANSFER FACILITY is designed, operated, fabricated, tested, inspected, and maintained in accordance with the following requirements. These requirements do not apply to handling heavy loads under a 10 CFR Part 50 license.

The permanent or stationary weldment structure of the TSC TRANSFER FACILITY shall be designed to comply with the stress limits of ASME Code, Section III, Subsection NF, Class 3 for linear structures. All compression loaded members shall satisfy the buckling criteria of ASME Code, Section III, Subsection NF.

The reinforced concrete structure of the facility shall be designed in accordance with ACI-349 and the factored load combinations set forth in ACI-318 for the loads defined in Table A4-1 shall apply. TRANSFER CASK and TSC lifting devices installed in the handling facility shall be designed, fabricated, operated, tested, inspected, and maintained in accordance with NUREG-0612, Section 5.1.

---

(continued)

If mobile load lifting and handling equipment is used at the facility, that equipment shall meet the guidelines of NUREG-0612, Section 5.1, with the following conditions:

- a. The mobile lifting device shall have a minimum safety factor of two over the allowable load table for the lifting device in accordance with the guidance of NUREG-0612, Section 5.1.6 (1)(a), and shall be capable of stopping and holding the load during a design earthquake event;
  - b. The mobile lifting device shall contain  $\leq 50$  gallons of fuel during operation inside the ISFSI;
  - c. Mobile cranes are not required to meet the guidance of NUREG-0612, Section 5.1.6(2) for new cranes;
  - d. The mobile lifting device shall conform to the requirements of ASME B30.5, "Mobile and Locomotive Cranes";
  - e. Movement of the TSC or STORAGE CASK in a horizontal orientation is not permitted.
-

**Table A4-1 Load Combinations and Service Condition Definitions for the TSC Handling and Transfer Facility Structure**

Load Combination	ASME Section III Service Condition for Definition of Allowable Stress	Note
<p style="text-align: center;">D* D + S</p>	<p style="text-align: center;">Level A</p>	<p style="text-align: center;">All primary load bearing members must satisfy Level A stress limits</p>
<p style="text-align: center;">D + M + W'<sup>1</sup> D + F D + E D + Y</p>	<p style="text-align: center;">Level D</p>	<p style="text-align: center;">Factor of safety against overturning shall be <math>\geq 1.1</math>, if applicable.</p>

- D = Crane hook dead load
- D\* = Apparent crane hook dead load
- S = Snow and ice load for the facility site
- M = Tornado missile load of the facility site<sup>1</sup>
- W' = Tornado wind load for the facility site<sup>1</sup>
- F = Flood load for the facility site
- E = Seismic load for the facility site
- Y = Tsunami load for the facility site

1. Tornado missile load may be reduced or eliminated based on a Probabilistic Risk Assessment for the facility site.

## 5.0 ADMINISTRATIVE CONTROLS AND PROGRAMS

5.1 Radioactive Effluent Control Program

---

- 5.1.1 A program shall be established and maintained to implement the requirements of 10 CFR 72.44 (d) or 10 CFR 72.126, as appropriate.
- 5.1.2 The MAGNASTOR SYSTEM does not create any radioactive materials or have any radioactive waste treatment systems. Therefore, specific operating procedures for the control of radioactive effluents are not required. LCO 3.3.2, TSC Surface Contamination, provides assurance that excessive surface contamination is not available for release as a radioactive effluent.
- 5.1.3 This program includes an environmental monitoring program. Each general license user may incorporate MAGNASTOR SYSTEM operations into their environmental monitoring program for 10 CFR Part 50 operations.

5.2 TSC Loading, Unloading, and Preparation Program

---

A program shall be established to implement the FSAR, Chapter 9 general procedural guidance for loading fuel and components into the TSC, unloading fuel and components from the TSC, and preparing the TSC and STORAGE CASK for storage. The requirements of the program for loading and preparing the TSC shall be completed prior to removing the TSC from the 10 CFR Part 50 structure. The program requirements for UNLOADING OPERATIONS shall be maintained until all spent fuel is removed from the spent fuel pool and TRANSPORT OPERATIONS have been completed on the last STORAGE CASK. The program shall provide for evaluation and control of the following requirements during the applicable operation:

- a. Verify that no TRANSFER CASK handling or STORAGE CASK handling using the lifting lugs occurs when the ambient temperature is  $< 0^{\circ}\text{F}$ . This limit is NOT applicable to the stainless steel MTC or PMTC.
- b. The water temperature of a water-filled, or partially filled, loaded TSC shall be shown by analysis and/or measurement to be less than boiling at all times.
- c. Verify that the drying time, cavity vacuum pressure, and component and gas temperatures ensure that the fuel cladding temperature limit of  $400^{\circ}\text{C}$  is not exceeded during TSC preparation activities, including TRANSFER OPERATIONS, and that the TSC is adequately dry. For fuel with burnup  $> 45 \text{ GWd/MTU}$ , limit cooling cycles to  $\leq 10$  for temperature changes greater than  $65^{\circ}\text{C}$ .
- d. Verify that the helium backfill purity and mass assure adequate heat transfer and preclude fuel cladding corrosion.
- e. The integrity of the inner port cover welds to the closure lid at the vent port and at the drain port shall be verified in accordance with the procedures in Section 9.1.1.

---

(continued)

- 
- f. Verify that the time to complete the transfer of the TSC from the TRANSFER CASK to the CONCRETE CASK and from a CONCRETE CASK to another CONCRETE CASK assures that the fuel cladding temperature limit of 400°C is not exceeded.
  - g. The surface dose rates of the STORAGE CASK are adequate to allow proper storage and to assure consistency with the offsite dose analysis.
  - h. The equipment used to move the loaded STORAGE CASK onto or from the ISFSI site contains no more than 50 gallons of fuel.

This program will control limits, surveillances, compensatory measures and appropriate completion times to assure the integrity of the fuel cladding at all times in preparation for and during LOADING OPERATIONS, UNLOADING OPERATIONS, TRANSPORT OPERATIONS, TRANSFER OPERATIONS and STORAGE OPERATIONS, as applicable.

---

### 5.3 Transport Evaluation Program

---

A program that provides a means for evaluating transport route conditions shall be developed to ensure that the design basis impact g-load drop limits are met. For lifting of the loaded TRANSFER CASK or STORAGE CASK using devices that are integral to a structure governed by 10 CFR Part 50 regulations, 10 CFR Part 50 requirements apply. This program evaluates the site-specific transport route conditions and controls, including the transport route road surface conditions; road and route hazards; security during transport; ambient temperature; and equipment operability and lift heights. The program shall also consider drop event impact g-loading and route subsurface conditions, as necessary.

---

### 5.4 ISFSI Operations Program

---

A program shall be established to implement FSAR requirements for ISFSI operations.

At a minimum, the program shall include the following criteria to be verified and controlled:

- a. Minimum STORAGE CASK center-to-center spacing.
- b. ISFSI pad parameters (i.e., thickness, concrete strength, soil modulus, reinforcement, etc.) are consistent with the FSAR analyses.
- c. Maximum STORAGE CASK lift heights ensure that the g-load limits analyzed in the FSAR are not exceeded.

---

(continued)

---

**5.5 Radiation Protection Program**

---

- 5.5.1 Each cask user shall ensure that the 10 CFR Part 50 radiation protection program appropriately addresses dry storage cask loading and unloading, and ISFSI operations, including transport of the loaded STORAGE CASK outside of facilities governed by 10 CFR Part 50 as applicable. The radiation protection program shall include appropriate controls and monitoring for direct radiation and surface contamination, ensuring compliance with applicable regulations, and implementing actions to maintain personnel occupational exposures ALARA. The actions and criteria to be included in the program are provided as follows.
- 5.5.2 Each user shall perform a written evaluation of the TRANSFER CASK and associated operations, 30 days prior to first use, to verify that it meets public, occupational, and ALARA requirements (including shielding design and dose characteristics) in 10 CFR Part 20, and that it is consistent with the program elements of each user's radiation protection program. The evaluation should consider both normal operations and unanticipated occurrences, such as handling equipment malfunctions, during use of the transfer cask.
- 5.5.3 As part of the evaluation pursuant to 10 CFR 72.212(b)(5)(iii), the licensee shall perform an analysis to confirm that the dose limits of 10 CFR 72.104(a) will be satisfied under actual site conditions and ISFSI configuration, considering the number of casks to be deployed and the cask contents.
- 5.5.4 Each user shall establish limits on the surface contamination of the STORAGE CASK, TSC and TRANSFER CASK, and procedures for the verification of meeting the established limits prior to removal of the components from the 10 CFR Part 50 structure. Surface contamination limits for the TSC prior to placement in STORAGE OPERATIONS shall meet the limits established in LCO 3.3.2.

---

**5.6 Special Requirements for the First System Placed in Service**

---

The heat transfer characteristics and thermal performance of the MAGNASTOR SYSTEM will be validated by recorded mass flow measurements in the air flow cooling passages of the first system placed in service with a heat load equal to or greater than 30 kW. A letter report summarizing the results of the measurements with respect to analyses of the actual canister content will be submitted to the NRC in accordance with 10 CFR 72.4 within 60 days of placing the loaded cask on the ISFSI pad. The report will include a comparison of the calculated mass flow of the MAGNASTOR SYSTEM at the loaded heat load to the measured mass flow. A report is not required to be submitted for the MAGNASTOR SYSTEMS that are subsequently loaded, provided that the performance of the first system placed in service with a heat load of  $\geq 30$  kW is demonstrated by the comparison of the calculated and measured mass flow rates.

---

(continued)

5.7 Training Program

---

A training program for the MAGNASTOR system shall be developed under the general licensee's systematic approach to training (SAT). Training modules shall include comprehensive instructions for the operation and maintenance of the MAGNASTOR system and the independent spent fuel storage installation (ISFSI) as applicable to the status of ISFSI operations.

5.8 Preoperational Testing and Training Exercises

---

A dry run training exercise on loading, closure, handling, unloading, and transfer of the MAGNASTOR system shall be conducted by the licensee prior to the first use of the system to load spent fuel assemblies. The training exercise shall not be conducted with spent fuel in the TSC. The dry run may be performed in an alternate step sequence from the actual procedures, but all steps must be performed. The dry run shall include, but is not limited to, the following:

- a. Moving the STORAGE CASK into its designated loading area
- b. Moving the TRANSFER CASK containing the empty TSC into the spent fuel pool
- c. Loading one or more dummy fuel assemblies into the TSC, including independent verification
- d. Selection and verification of fuel assemblies to ensure conformance with appropriate loading configuration requirements
- e. Installing the closure lid
- f. Removal of the TRANSFER CASK from the spent fuel pool
- g. Closing and sealing of the TSC to demonstrate pressure testing, vacuum drying, helium backfilling, welding, weld inspection and documentation, and leak testing
- h. TRANSFER CASK movement through the designated load path
- i. TRANSFER CASK installation on the CONCRETE CASK
- j. Transfer of the TSC to the CONCRETE CASK
- k. CONCRETE CASK LID assembly installation
- l. Transport of the STORAGE CASK to the ISFSI
- m. TSC removal from the CONCRETE CASK
- n. TSC unloading, including refueling and weld removal or cutting

Appropriate mock-up fixtures may be used to demonstrate and/or to qualify procedures, processes or personnel in welding, weld inspection, vacuum drying, helium backfilling, leak testing and weld removal or cutting. Previously completed and documented demonstrations of specific processes and procedures may be used, as applicable, for implementation of the MAGNASTOR SYSTEM at a specific loading facility.