



## JOB PERFORMANCE MEASURE VALIDATION CHECKLIST

**NOTE:** All steps of this checklist should be performed upon initial validation.  
Prior to JPM usage, revalidate JPM using steps 9 and 13 below.

1. Task description and number, JPM description and number are identified. \_\_\_\_\_
  2. Knowledge and Abilities (K/A) references are included. \_\_\_\_\_
  3. Performance location specified. (in-plant, control room, simulator, or other) \_\_\_\_\_
  4. Initial setup conditions are identified. \_\_\_\_\_
  5. Initiating cue (and terminating cue if required) are properly identified. \_\_\_\_\_
  6. Task standards identified and verified by instructor or SME review. \_\_\_\_\_
  7. Critical steps meet the criteria for critical steps and are identified with an asterisk (\*). \_\_\_\_\_
  8. IAW NUREG 1021 Appendix C, clearly identify the task standard (i.e., the predetermined qualitative or quantitative outcome) against which task performance will be measured. \_\_\_\_\_
  9. Verify the procedure(s) referenced by this JPM reflects the current revision: \_\_\_\_\_
- |            |   |           |     |
|------------|---|-----------|-----|
| Procedure: | QOS 0005-01, OPERATIONS DEPARTMENT WEEKLY SUMMARY OF DAILY SURVEILLANCE       | Revision: | 172 |
| Procedure: | QOS 0005-S01, OPERATIONS DEPARTMENT WEEKLY SUMMARY OF DAILY SURVEILLANCE UNIT | Revision: | 200 |
| Procedure: |   | Revision: |     |
10. Verify cues both verbal and visual are free of conflict. \_\_\_\_\_
  11. Verify performance time is accurate. \_\_\_\_\_
  12. If the JPM cannot be performed as written with proper responses, then revise the JPM. \_\_\_\_\_
  13. When JPM is initially validated, sign and date JPM cover page. For subsequent validations, sign and date below: \_\_\_\_\_

_____ / _____ SME / Instructor (Print/Sign)	_____ Date
--	---------------

_____ / _____ SME / Instructor (Print/Sign)	_____ Date
--	---------------

_____ / _____ SME / Instructor (Print/Sign)	_____ Date
--	---------------

**Revision Record (Summary)**

<b>Revision #</b>	<b>Summary</b>
00	New JPM developed for the 2024 ILT NRC Exam IAW NUREG 1021 Rev. 12, Section ES-3.2, D.

## SIMULATOR SETUP INSTRUCTIONS

1. Reset the simulator to IC-20 (75% power), or any IC at power.

**NOTE:** It is okay to use a similar IC to the IC listed above, provided the IC actually used is verified to be compatible with this and other JPMs that are scheduled to be run concurrently.

2. Procedures required for JPM performance:

- Unmarked copy of QOS 0005-01, OPERATIONS DEPARTMENT WEEKLY SUMMARY OF DAILY SURVEILLANCE.

- QOS 0005-S01, page 21 with Sunday Shift 1 marked up as follows:

Step 30. Channel 14 – 85.8, Channel 15 – 85.7, Channel check – (√)

Step 31. Channel 1(A) – 85.7, Channel 2(B) – 85.7, 200A/B pt. 9 – 85.8, Channel check – (√)

Step 32. All boxes checked for Sunday

3. Insert the following overrides for temperature recorder readings:

- AOTR116028A1 85.73 TR 1640-8 Channel 1(A)
- AOTR116028A2 85.81 TR 1640-8 Channel 1(B)
- AOTR11640200A9 73.91 TR 1640-200A Channel pt. 9
- AOTR11640200B9 85.82 TR 1640-200B Channel pt. 9
- AOTR11640200A1 0 TR 1640-8 Pt. 1
- AOTR1026020K 205 TR 260-20, 3C Relief Valve tailpipe
- AOTR1026020N 85.73 TR 260-20 Channel 14
- AOTR1026020O 85.74 TR 260-20 Channel 15

4. This completes the setup for this JPM.

### INITIAL CONDITIONS

- You are the extra NSO.
- It is Monday Shift 1.
- Unit 1 is operating at rated power.
- QOS 0005-01, OPERATION DEPARTMENT WEEKLY SUMMARY OF DAILY SURVEILLANCE is in progress.
- The Unit NSO has requested you to perform steps 30 thru 32 and document the results on QOS 0005-S01.
- This JPM is NOT time critical.

### INITIATING CUE

Perform steps 30 thru 32 and document the results on QOS 0005-S01, OPERATION DEPARTMENT WEEKLY SUMMARY OF DAILY SURVEILLANCE.

Inform the Unit Supervisor of any discrepancies.

**Provide examinee with:** Copy of QOS 0005-01 and page 21 of QOS 0005-S01 with Sunday Shift 1 completed.

Fill in the JPM Start Time when the student acknowledges the Initiating Cue.  
.....

#### **Information For Evaluator's Use:**

UNSAT requires written comments on respective step.

\* Denotes critical steps.

Number any comments in the "Comment Number" column on the following pages. Then annotate that comment in the "Comments" section. The comment section should be used to document: the reason that a step is marked as unsatisfactory, marginal performance relating to management expectations, or problems the examinee had while performing the JPM. Comments relating to procedural, or equipment issues should be entered and tracked using the site's appropriate tracking system.

Some operations that are performed from outside of the control room may require multiple steps. These items may be listed as individual steps in this JPM. It is acceptable for the candidate to direct the local operator to perform groups of procedure steps instead of calling for each individual item to be performed.

The timeclock starts when the candidate acknowledges the initiating cue.  
.....

JPM Start Time: \_\_\_\_\_ JPM Sequence #: \_\_\_\_\_ of \_\_\_\_\_

<b><u>Task Standard:</u></b>					
Perform the daily surveillance of Torus air/water and Safety/Relief Valve tailpipe temperatures and identify Torus water temperature readings on TR 1640-200A and 200B are NOT within 10°F and TR 0260-20 channel 11 (3C Relief Valve tailpipe temperature) is > 195°F using QOS 0005-01 and QOS 0005-S01.					
<b><u>STEP</u></b>	<b><u>ELEMENT</u></b>	<b><u>STANDARD</u></b>	<b>SAT</b>	<b>UNSAT</b>	<b>Comment Number</b>
Step 30.	Obtains and records Torus Air temperature and verifies readings within 10°F.	At the 901-21 panel from TR 260-20 and records: Channel 14 – 85.7 Channel 15 – 85.7  Verifies readings are within 10°F and marks Channel check box – (√)	<input type="checkbox"/>	<input type="checkbox"/>	—
*Step 31.	Obtains and records Torus Water temperature and verifies readings are < 95°F and within 10°F.	At the 901-21 panel from TR 1-1640-8 and records: Channel 1(A) – 85.7 Channel 2(B) – 85.8  At the 901-36 panel from TR 1640-200A and 200B and records: 200A pt. 9 – 73.9 200B pt. 9 – 85.8  Verifies all readings are < 95°F. *Identifies that pt. 9 on TR 1640-200A and 200B are NOT within 10°F.*  Does NOT mark Channel check box.	<input type="checkbox"/>	<input type="checkbox"/>	—

<u>STEP</u>	<u>ELEMENT</u>	<u>STANDARD</u>	SAT	UNSAT	Comment Number
<b>Evaluator Note: The examinee may observe that the Div. I point 1 temperature element is reading 0. This is indicative of a problem with that thermocouple and is causing the low average bulk water temperature reading on TR 1640-200A. It is not required that the examinee identifies this as a cause (Did not occur in validation).</b>					
*Step 32.	Verifies Safety Valve tailpipe temperatures are < 225°F. and Verifies Relief Valve tailpipe temperatures are < 195°F.	At the 901-21 panel on TR 0260-20 verifies the following: Channels 1 thru 8 are reading < 225°F. Channels 9 thru 13 are reading < 195°F. *Identifies channel 11, the 3C Relief Valve tailpipe temperature, is reading 205°F.* Does NOT check box.	<input type="checkbox"/>	<input type="checkbox"/>	—
JPM Step 4*	Reports surveillance discrepancies to the Unit Supervisor.	Informs the Unit Supervisor of the following: – Torus Water temperatures on TR 1640-200A and 200B pt. 9 are NOT within 10°F. – TR 0260-20 Channel 11 the 3C Relief Valve tailpipe temperature is reading 205°F.	<input type="checkbox"/>	<input type="checkbox"/>	—
<b>CUE:</b>	<b>As the Unit Supervisor, state:            “I’ll contact Instrument Maintenance to investigate the off normal readings and the System Engineer with the WEC SRO to evaluate the 3C Relief Valve tailpipe temperature for seat or pilot valve leakage per QCOS 0203-02.”</b>				
<b>EVALUATOR NOTE: The examinee should inform you the task is complete.</b>					

JPM Stop Time: \_\_\_\_\_

.....

**JPM SUMMARY**
**Operator's Name:** \_\_\_\_\_ **Emp. ID#:** \_\_\_\_\_

**Job Title:**  EO  RO  SRO  FS  STA/IA  SRO Cert

**JPM Title:** Operations Daily Surveillance of Torus and Safety/Relief Valve Instrumentation

**JPM Number:** RO A1.1

**Revision Number:** 00
**Task Number and Title:** **SR-1601-K20 a/b** (Freq: LIC=B) Given various plant conditions, a.) EVALUATE the following Containment Systems indications/ responses and b.) DETERMINE if the indication/ response is expected and normal.

d. Torus pressure, air temperature, water level and temperature

**Task Standard:** Perform the daily surveillance of Torus air/water and Safety/Relief Valve tailpipe temperatures and identify Torus water temperature readings on TR 1640-200A and 200B are NOT within 10°F and TR 0260-20 channel 11 (3C Relief Valve tailpipe temperature) is > 195°F using QOS 0005-01 and QOS 0005-S01.
**K/A Number and Importance:** **K/A:** 2.1.19

**Rating:** RO/SRO 3.9/3.8

**Suggested Testing Environment:** Simulator

**Alternate Path:**  Yes  No **SRO Only:**  Yes  No **Time Critical:**  Yes  No

**Reference(s):**

Procedure:	QCOS 0005-01, OPERATIONS DEPARTMENT WEEKLY SUMMARY OF DAILY SURVEILLANCE	Revision: <u>172</u>
Procedure:	QOS 0005-S01, OPERATIONS DEPARTMENT WEEKLY SUMMARY OF DAILY SURVEILLANCE UNIT	Revision: <u>199</u>
Procedure:	_____	Revision: _____

**Actual Testing Environment:**  Simulator  Control Room  In-Plant  Other

**Testing Method:**  Simulate  Perform

**Estimated Time to Complete:** 15 minutes

**Actual Time Used:** \_\_\_\_\_ minutes

**EVALUATION SUMMARY:**

 Were all the Critical Elements performed satisfactorily?  Yes  No

 The operator's performance was evaluated against standards contained within this JPM and has been determined to be:  Satisfactory  Unsatisfactory

**NOTE:** Enter finalized grading, comments, and notes relevant to this evaluation in the associated TQ-AA-150-F03A/B. (See AR [4282419](#)).

**Evaluator's Name (Print):** \_\_\_\_\_

**Evaluator's Signature:** \_\_\_\_\_ **Date:** \_\_\_\_\_

**Page Intentionally Left Blank**

### **INITIAL CONDITIONS**

- You are the extra NSO.
- It is Monday Shift 1.
- Unit 1 is operating at rated power.
- QOS 0005-01, OPERATION DEPARTMENT WEEKLY SUMMARY OF DAILY SURVEILLANCE is in progress.
- The Unit NSO has requested you to perform steps 30 thru 32 and document the results on QOS 0005-S01.
- This JPM is NOT time critical.

### **INITIATING CUE**

Perform steps 30 thru 32 and document the results on QOS 0005-S01, OPERATION DEPARTMENT WEEKLY SUMMARY OF DAILY SURVEILLANCE.

Inform the Unit Supervisor of any discrepancies.

OPERATION DEPARTMENT WEEKLY SUMMARY OF DAILY SURVEILLANCE

DAY SHIFT	SUN			MON			TUES			WED			THURS			FRI			SAT		
	1	2	3	1	2	3	1	2	3	1	2	3	1	2	3	1	2	3	1	2	3
	1	2	3	1	2	3	1	2	3	1	2	3	1	2	3	1	2	3	1	2	3

30. TORUS AIR TEMPERATURE (TR 260-20) (Required once per day in MODES 1 and 2 AND prior to entering required MODE.)

Channel 14	85.8																						
Channel 15	85.7																						
Channel check - within 10°F of each other. (✓)	✓																						

31. TORUS WATER TEMPERATURE (Required once per day in MODES 1, 2 and 3 AND prior to entering required MODE.)

Verify readings are < 95°F

1640-8 Channel 1(A)	85.1																						
1640-8 Channel 2(B)	85.7																						
1640-200A pt 9	85.8																						
1640-200B pt 9	85.8																						
Channel check - within 10° of each other. (✓)	✓																						

32. RELIEF AND SAFETY VALVE TAILPIPE TEMPERATURES (TR 260-20) (Required once per shift during MODES 1, 2 and 3 and prior to entering required MODES.)

Verify Safety Valve temperature readings ≤ 225°F.

Verify Relief and Safety/Relief Valve temperature readings < 195°F. Discern whether temperature increase is due to seat leakage or pilot leakage using QCOS 0203-02, Att. B.

Safety Valves Channels 1 thru 8	✓	✓	✓																				
Relief & Safety/Relief Valves Channels 9 thru 13	✓	✓	✓																				

OPERATIONS DEPARTMENT WEEKLY  
SUMMARY OF DAILY SURVEILLANCE

A. PURPOSE

To outline the use of the Operations Department Weekly Summary of Daily Surveillance Sheet (QOS 0005-S01).

B. REFERENCES

1. LER 1-97-001, Technical Specification Required Readings Were Not Completed Within the Required Time Frequency After Changing from Eight Hour to Twelve Hour Shifts.
2. NDIT No. MSD-98-019, Rev. 0, Setpoint Change for HCU Scram Accumulator Minimum Setpoint Pressure.
3. NDIT No. QDC-98-151, Minimum Torus Level Requirement for Technical Specifications.
4. PIF Q1999-00286, SBO Building Temperature Parameters Not Monitored on Regular Basis.
5. LER 1-98-009, SBLC Pump Suction Heat Tracing Operability.
6. LER 1-98-006, Reactor Building Post Loss of Coolant Accident Temperatures are Higher than Values used for the Environmental Qualification of Electrical Equipment due to Unvalidated Engineering Judgment.
7. Engineering Report ER-KOP-448-01-001, Evaluation of Loading Capacity of the 4000 Amp Bus Duct at Quad Cities and Dresden.
8. CR 170462, Actual Reactor Pressure greater than indicated.
9. QDC-1100-I-0595, SBLC Pump Suction Piping Temperature Indication Accuracy Calculation.
10. WC-AA-101, On-Line Work Control Process.
11. EN-QC-402-001, NPDES Temperature & Flow Determinations.
12. EC 387133, Quad Cities Station Ventilation Chimney Illumination.

6. Technical Specifications LCO 3.0.4 provides guidance for entry into a MODE or other specified condition in the Applicability with inoperable equipment required by Tech Specs. Additional guidance is provided in WC-AA-101.
7. Readings must be obtained while in the applicable operating mode AND prior to entering another operating mode, in order to comply with E.4. It is expected that when obtaining readings for a MODE, prior to entering that MODE, that there will be readings that are outside of the indicated band. For any reading found outside the expected band, the value should be recorded and circled. The step number, date and reason for the discrepancy should be noted on the "REMARKS" page at the end of the surveillance. WHEN the problem is resolved, THEN the date should be entered in the RESOLVED column. For example:

STEP#/DATE	EXPLANATION	DATE RESOLVED
41/1-1-99	PRESSURE LOW, EO WILL CHANGE BOTTLE	1-2-99

This is NOT required for readings that are outside the normal band due to plant conditions, such as a Unit Shutdown.

Once a discrepancy is noted on the "REMARKS" page, it need NOT be recorded again unless the discrepancy has been resolved and has now recurred.

8. Acceptable Channel check variations included are for normal power operation. There may be exceptions to these bands as determined by the Unit Supervisor.
9. Control Room component light indication issues (i.e., flickering or extinguished light that cannot be fixed by replacing bulb) may be indicative of operability issues with the component (i.e., control power issues versus a degraded socket). IF Control Room component indication issues occur, THEN:
  - a. Immediately initiate actions to determine operability of the component (i.e., control power issues versus a degraded socket).
  - b. Review TS 3.3.3.1, Post Accident Monitoring (PAM) Instrumentation for Primary Containment Isolation Valves (PCIVs) with lost indication.
  - c. Review TS 3.6.1.3, Primary Containment Isolation Valves (PCIVs) for PCIVs determined to be inoperable.

- b. Drywell Pressure. (Required in MODES 1, 2, 3 and prior to entering required mode.)

Once per shift, record Drywell pressure indications from both ranges of PR 1640-12, and from PIC 1640-11. Verify Drywell Pressure  $\leq$  1.5 psig.

Wide range pressure on PR 1640-12 has a band of -10" Hg to 70 psig and may not be calibrated to an accuracy to reliably use as a  $<$  1.5 psig verification. Narrow range on PR 1640-12 is the preferred channel for verification of Drywell pressure.

- c. Drywell-to-Suppression Chamber Differential Pressure. (Required in MODE 1.)

Once per shift, record differential pressure (psid) from DPC 1(2)-1640-15 on the 90X-3 panel. IF DPC 1(2)-1640-15 is unavailable, THEN calculate dP by subtracting Suppression Chamber pressure (PI 1602-1) from Drywell pressure (PIC 1640-11 or PR 1640-12). Verify digital dP or calculated dP is  $>$  1.0 psid above the pressure of the Suppression Chamber.

- d. Wide Range Drywell Pressure. (Required in MODES 1, 2 and prior to entering required mode.)

Daily, record Drywell pressures from PI 1640-11A and 11B on 90X-3 panel and verify readings are within 10 psig of each other. Perform CHANNEL CHECK daily.

3. Torus Water Level.

TS 3.6.2.2  
TS 3.5.2  
TS 3.3.3.1  
NDIT No. QDC-98-151

5. Target Rock pneumatic supply pressure (DW pneumatic supply pressure). (Required in MODES 1 and 2 AND in MODE 3 with Reactor pressure > 150 psig, AND prior to entering required MODE/CONDITION.)

TS SR 3.5.1.12

Once per week, record and verify DW pneumatic header pressure is  $\geq 80$  psig. This verifies that the relief valve function of the Target Rock SRV is operable.

6. Reactor Vessel Water Level. (Required in MODES 1, 2, 3 and prior to entering required MODE.)

TS 3.3.3.1  
TRM 3.3.d

Daily, record Reactor vessel wide range water level from LI 263-106A and 106B, on 90X-3 panel. IF on scale, THEN verify readings are within 12" of each other. Perform CHANNEL CHECK daily.

7. Drywell Air Temperature. (Required in MODES 1, 2, 3 and prior to entering required MODE.)

TS 3.6.1.5  
TRM 3.3.b

Daily, record temperatures from TR 2340-9, points 7-12 on 90X-3 panel and verify drywell average air temperature is  $\leq 150^{\circ}\text{F}$  in accordance with QCOS 1600-53. Perform CHANNEL CHECK daily.

8. Reactor Coolant Conductivity Monitor. (Required in MODES 1, 2 and 3 and prior to entering required MODE.)

TRM 3.4.b.  
UFSAR Section 5.2.3.2.1  
QCOS 0201-05

Twice per shift, verify Reactor Coolant Continuous Conductivity Monitor, X-1290-25, is operable per QCOS 0201-05. To be considered operable, at least one of the following conditions must apply:

- a. AO X-220-44 and 45, RX RECIRC SAMPLE VLVS, are open.
- b. The RWCU System is operating with at least one pump running.

Verify conductivity is less than Action Level 1 (CY-AB-120-100). IF the monitor is inoperable, THEN enter QCOS 0201-06.

- c. In MODES 2, 3, 4, and 5, verify the channel count rate is  $\geq 3.0$  cps, or  $\geq 0.7$  cps with a signal to noise ratio  $\geq 20:1$  once per 12 hours during CORE ALTERATIONS and at least once per 24 hours at other times. (NOT required to be met with less than or equal to four fuel assemblies adjacent to the SRM and no other fuel assemblies in the associated core quadrant.)
12. Control Rod Scram Accumulators. (Required in MODES 1, 2, 3, 4, 5 and prior to entering required mode.)

NDIT MSD-98-019, Rev. 0.  
TS 3.1.5  
TS 3.9.5

Once per shift, verify all accumulator pressures  $\geq 940$  psig by accumulator alarms being cleared. IF accumulator alarm present, THEN verify local pressure  $\geq 940$  psig. IF accumulator pressure is  $< 940$  psig, THEN declare CRD accumulator inoperable and enter QCOS 0300-14. Recharge CRD accumulator within 8 hours or declare CRD inoperable.

In MODES 3 and 4 this is applicable for the accumulators associated with each control rod withdrawn per Technical Specification 3.10.2 and 3.10.3.

IF all rods inserted in MODE 5, THEN enter N/A. In MODE 5 this is applicable for the accumulators associated with each withdrawn control rod and is NOT applicable to control rods removed per Technical Specification 3.10.4 or 3.10.5.

13. Control Rod Position Indication. (Required once per day in MODE 1 and 2, and prior to entering required MODE/condition.)

TS 3.1.3

Daily and during control rod withdrawal, observe rod display for proper control rod position indication (Bases SR 3.1.3.1). Record any rod position indication discrepancy. Consult a QNE if rod movement to a known position is required.

- b. (Required once per shift when  $\geq 25\%$  rated thermal power and prior to exceeding  $25\%$  rated thermal power.) WHEN Reactor power is  $\geq 25\%$  rated thermal power, THEN verify Reactor pressure via computer point C109(C209) or C109 FILT(C209 FILT) or meter 1(2)-640-25A on Panel 901(2)-5 to be in the normal operating region of Core Thermal Power vs. Reactor Pressure curve.

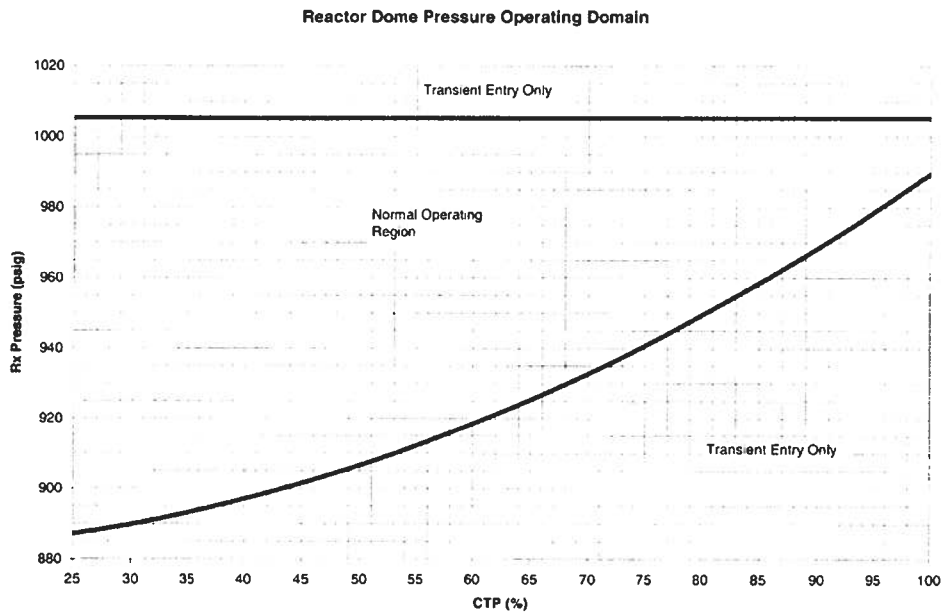

17. Explosive Gas Mixture and Explosive Gas Monitoring.  
(Required during operation of the Offgas Holdup  
System.)

TS 5.5.8.a  
TRM 3.3.c  
TRM 3.7.e

Daily, verify H2 Concentration in the Offgas Holdup  
System is  $< 4\%$  by volume as indicated on recorder  
5440-17. IF a H2 monitor is inoperable, THEN refer to  
TRM 3.3.c, TRM 3.7.e, and QCOS 2700-02.

Daily, perform CHANNEL CHECK by verifying that the  
hydrogen analyzer is ON, is drawing sample flow, and  
has NO trouble lights/alarms actuated. For 1(2)A  
Analyzer, verify Annunciator 901(2)-54 A-3 is NOT in  
alarm. In addition, a qualitative check should be made  
of indicated off-gas oxygen concentration, recombiner  
temperatures, and off-gas flow to the chimney. Off-gas  
oxygen concentration less than 12%, an unexplained drop  
in recombiner temperatures, or increase in off-gas flow  
to the chimney could be indicative of incomplete  
recombination and hydrogen entering the holdup portion  
of the system.

18. Drywell Rad Monitor Instrument Check. (Required in  
MODES 1, 2, 3 and prior to entering required mode.)

TS 3.3.3.1  
TS 3.3.6.1

- a. Once per shift, record readings from drywell  
Rad computer points R123(223) and R122(222)  
[preferred - record to nearest 1/10<sup>th</sup> R/hr] OR  
from drywell Rad monitors 2419A and 2419B on  
Panels 90X-55 and 56 [back up].
- b. Once per shift, perform channel check by verifying  
readings meet the following criteria:
- (1) Within 2 R/hr of each other for lower  
channel indication of  $\leq 3$  R/hr.
  - (2) Within 3 R/hr of each other for lower  
channel indication of  $> 3$  R/hr and  $< 10$  R/hr.
  - (3) Within 10 R/hr of each other for indication  
 $\geq 10$  R/hr.
  - (4) Individually reading  $\geq 2$  R/hr for power  
level  $\geq 700$  MWe. (IF  $< 2$  R/hr with power  
level  $\geq 700$  MWe, THEN notify US and IMD.
  - (5) An individual reading that is "flat-lining"  
at 1 R/hr requires evaluation/validation of  
proper instrument function.

20. Jet Pump Flow Distribution Comparison, QCOS 0202-07.  
(Required in MODES 1 and 2, 4 hours after associated recirculation loop is in operation and 24 hours after > 25% RTP.)

TS 3.4.2

Daily, obtain jet pump readings from Panel 901(2)-38 and perform QCOS 0202-07.

- a. IF either of the following conditions are met, THEN information may be obtained from the RCCS Jet Pump Surveillance display:
- (1) The cycle number on the Jet Pump Surveillance display is for the current cycle.
  - (2) The cycle number on the Jet Pump Surveillance display matches the cycle number on the attachments in QCOS 0202-07 AND use of the Cycle data has been approved by a QNE on QCGP 4-1, Attachment A, Special Instructions.
- b. Attach a copy of QCOS 0202-07 OR a dated screen print of the Jet Pump Surveillance display to QOS 0005-S01.
21. Core Shroud Access Hole Cover Integrity. (Required in MODES 1 and 2.)

UFSAR Sections 6.3.3.1.2.2, 6.3.3.2.2.2.  
SIL No. 462 Supplement 2, Revision 1.

Once per day, based on current core thermal power, flow control line and core flow, determine if there has been an unexplained power decrease of >5% core thermal power with no corresponding change in core flow or an increase in the total core flow. Consideration should be given for changes in plant system/components operation, Xenon transients, heat balance input parameters, etc.

- a. IF an unexplained power decrease of >5% core thermal power with no corresponding change in core flow or an increase in the total core flow, THEN notify QNE to assist in assessing correlation to access hole cover integrity.
- b. WHEN the Reactor is in MODES 1 or 2, THEN Shroud Access Hole Cover shall be intact. IF it is determined that Shroud Access Hole cover has failed, THEN an orderly shutdown shall be initiated AND Reactor shall be in at least MODE 3 within 12 hours.

- b. Residual Heat Removal (RHR) - High Water Level.  
(Required in MODE 5 with irradiated fuel in the reactor pressure vessel (RPV) and the water level  $> 23$  feet above the top of the RPV flange and prior to entering MODE 5.) Perform surveillance requirement once per shift.

Once per shift, verify each required RHR shutdown cooling subsystem manual and power operated valve in the flow path, that is NOT locked, sealed or otherwise secured in position, is in the correct position or can be aligned to the correct position.

- c. Residual Heat Removal (RHR) - Low Water Level.  
(Required in MODE 5 with irradiated fuel in the reactor pressure vessel (RPV) and the water level  $< 23$  feet above the top of the RPV flange and prior to entering MODE 5.) Perform surveillance requirement once per shift.

Once per shift, verify each required RHR shutdown cooling subsystem manual and power operated valve in the flow path, that is NOT locked, sealed or otherwise secured in position, is in the correct position or can be aligned to the correct position. SDC Operability is determined via one of the following:

- (1) One loop of SDC in Operation per QCOP 1000-05.
- (2) One loop of SDC secured, but lined up for subsequent restart per QCOP 1000-05.
- (3) At least one loop of RHR in stand by lineup per QCOP 1000-49(50).

26. Service Water Effluent Gross Activity Monitor.

ODCM Table 12.2.1-1

Perform CHANNEL CHECK daily. Record reading from RR 1705-12 on the 90X-2 panel. Verify reading is between 100 and 10,000 CPM. IF RR 1705-12 is inoperable, THEN Service Water Effluent Gross Activity may be obtained from the Eberline Control Terminals (0-1740-200 or 201) on the 912-4 panel per QCOP 1700-11 or Computer Point R119(R229). IF Service Water Effluent Gross Activity Monitor is inoperable, THEN enter QCOS 1700-04.

28. Main Steam Line Radiation Monitors and Mechanical Vacuum Pump Trip Instrumentation. (Required during MODE 1 and 2 with the mechanical vacuum pump in service and any main steam line NOT isolated AND during MODE 1 AND during MODE 2 and 3 with any main steam line NOT isolated and steam jet air ejector (SJAE) in operation AND prior to entering required MODE/condition.)

TS 3.3.7.2  
CY-QC-130-404

Perform CHANNEL CHECK once per shift. Once per shift, record readings in scientific notation from MSL Rad Monitors 1705 A-D on the 90X-10 panel. Verify readings are all within 150 units of each other. Check recorders 1(2)-1705-11A and -11B for normal trend.

MODE 1 ONLY; NOT APPLICABLE DURING NORMAL UNIT START UP/POWER ASCENSION

IF activity increases/decreases by  $> 50\%$  from the previous reading OR the reading is NOT within 50% to 90% of the current high alarm setpoint 'as expected due to plant conditions changing (i.e., power level and H<sub>2</sub> addition status/injection rate), AND IF anticipated duration is  $< 72$  hours, THEN NO actions are required to address the temporary change to plant conditions.

- IF anticipated duration is  $> 72$  hours, THEN notify Chemistry to calculate new MSL Rad Monitor High alarm setpoints per CY-QC-130-404 within 72 hours AND notify IMD to implement the new setpoints.
- IF reading is NOT within 50% to 90% of the current High Alarm setpoint (provided via CY-QC-130-404), THEN notify Chemistry to calculate new MSL Rad Monitor High alarm setpoints within 72 hours AND notify IMD to implement the new setpoints.

29. Reactor Building Ventilation Radiation Monitors and Refueling Floor Radiation Monitors. (Required at ALL times.)

TS 3.3.6.2                      TS 3.3.7.1  
ODCM 12.2.2                    ODCM Table 12.2.2-1

Once per shift, perform the following:

- a. Record readings from Reactor Building Ventilation Rad Monitor channels A & B on the 90X-10 panel. Verify readings are  $< 2$  mR/hr and within 1 mR/hr of each other. Perform CHANNEL CHECK once per shift.

32. Relief Valve and Safety Valve tailpipe temperatures (Required in MODES 1, 2, and 3 and prior to entering required MODE.)

Once per shift, review tailpipe temperatures of Relief and safety valves from channels 1 through 13 on TR 0260-20 on Panel 90X-21.

- a. IF a Safety Valve, channels 1 through 8, exceeds 225°F OR experiences a step change independent of changes in plant conditions, THEN refer to QCOS 0203-02.
- b. IF a Relief or Safety/Relief Valve, channels 9 through 13, exceeds 195°F OR experiences a step change independent of changes in plant conditions, THEN refer to QCOS 0203-02. Discern whether temperature increase is due to seat leakage or pilot leakage using QCOS 0203-02, Att. B.

33. Control Rod Drive Temperatures.

Once per day in Modes 1 and 2, monitor TR 1(2)-340-16, CRD HYDRAULIC DRIVE UNITS TEMP RECORDER, and verify all temperatures <350°F. IF any temperature is  $\geq 350^{\circ}\text{F}$ , THEN either verify appropriate actions for  $\geq 350^{\circ}\text{F}/\geq 400^{\circ}\text{F}$  have been taken per QCOS 0300-21 (IR initiated and penalties added) OR initiate an IR and perform actions of QCOS 0300-21 and TS 3.1.4.

34. SRMs. (Required in MODES 1, 2, 3, 4, 5 and prior to entering MODE 5 from no MODE.)

TS 3.3.1.2  
TRM 3.3.b

Once per shift, record readings from SRM channels 21-24 on the 90X-36 panel. Verify readings are within one decade of each other. Perform CHANNEL CHECK once per shift.

35. IRMs. (Required in MODE 2 and MODE 5 with any control rod withdrawn from a core cell containing one or more fuel assemblies, and prior to entering required MODE/condition. Required in MODE 3 and MODE 4 during TS special operations 3.10.2 and 3.10.3.)

TS 3.3.1.1

Perform CHANNEL CHECK once per shift.

c. Source Check.

ODCM Table 12.2.2-1

Once per day, source check monitors 1 and 2 by performing the following for each monitor:

- (1) Place SOURCE CHECK CHIMNEY GAS MON 1/2 switch to "CHK."
- (2) Verify alarms 912-1 E-3 and F-3 annunciate.
- (3) Record readings on QOS 0005-S01.
- (4) Place SOURCE CHECK CHIMNEY GAS MON 1/2 switch to "NOR" for at least 10 seconds.
- (5) Verify 912-1 E-3 and F-3 reset. Reset HI and HI HI lights on chassis "A"/"B."
- (6) Place SOURCE CHECK CHIMNEY GAS MON 1/2 switch to "LOCAL."

Verify the source check value is > 500 cps for each monitor. IF value of source check is < 500 cps, THEN enter QCOS 1700-03.

38. Radwaste Effluent Monitor (Unit One only).

ODCM Table 12.2.2-1 (Instrument Check)

Once per day:

- a. At the SPING terminal depress DATA, 10-01, ENTER.
- b. At the SPING terminal depress PRINT, FILE, ENTER.
- c. Record reading for Radwaste channel 10-01 and verify reading is in the E+02 to E+05 range.

Refer to QCOP 1700-11 as needed. IF Radwaste Effluent Gross Activity Monitor is inoperable, THEN refer to QCOS 1700-06.

41. ATWS Reactor Vessel Steam Dome Pressure Instrument Check. (Required in MODE 1 and prior to entering MODE 1.)

TS 3.3.4.1

Once per shift, record Reactor pressure readings obtained from PI 263-22A and 22C on the 220X-70A panel, and PI 263-22B and 22D on the 220X-70B panel in the Auxiliary Electric Room. Verify the four meters do NOT vary by more than 75 psig. IF the meters vary by more than this band, THEN initiate Work Request to calibrate the meters. Perform CHANNEL CHECK once per shift.

42. Reactor Vessel Steam Dome High Pressure. (Required in MODES 1, 2 and prior to entering required mode.)

TS 3.3.1.1

Once per shift, record Reactor pressure readings obtained from the master trip units 263-191A, B, C, and D in the Cable Spreading Room. Verify that the four meters do NOT vary by more than 75 psig. Perform CHANNEL CHECK once per shift.

43. CCST Level. (Required in MODES 1, 2, 3, 4, 5 and prior to entering required mode.)

TS 3.5.1 (MODES 1, 2, 3.)

TS 3.5.2 (MODES 4, 5.)

Once per shift, record Contaminated Condensate Storage Tank (CCST) level as read at local level indicators. In MODES 1, 2 and 3, verify level is > 10.5' (corresponds to > 12' actual level.) This is required to verify/maintain discharge piping full on the HPCI System, and therefore maintain HPCI System operability. In MODES 4 and 5, the Tech Spec level requirement will be met if CCST level is maintained within limits per table below.

Number of Tori with < 8.5' Water Level	Number of CCSTs Available	Minimum Indicated CCST Level to Ensure 140,000 gallons to RHR/CS
1	1	12'
1	2	10.5'
2	1	Not Allowed
2	2	12.0'

45. Toxic Gas Monitoring System. (Required in MODES 1, 2, 3, 4 and 5.)

TRM 3.3.e

- a. (Unit 1 Only)  
Once per shift, record Control Room Ventilation toxic gas reading NH<sub>3</sub> (Panel 0-9400-105 monitors 0-9400-121A, -121B, -122A and -122B) and verify readings between 0 and +30 ppm. IF toxic gas Monitoring Channel/System is inoperable, THEN perform QCOS 5750-06. Perform CHANNEL CHECK once per shift by verifying 0-9400-121A and -122A are within ± 10 ppm, and 0-9400-121B and -122B are within ± 10 ppm.

NOTE

The Meteorological Tower temperature indication (computer point R235) has a range of -22°F to +122°F. IF temperature is outside this band, THEN contact the National Weather Service as an alternate indication at 1-563-386-3815 OR 1-563-391-7094.

- b. (Unit 2 Only)  
Once per shift, record outside air temperature from computer point R235, or TI 1-5703-12B on Panel 912-5 if R235 is unavailable. IF outside air temperature is ≤ 32°F or sudden dramatic drop of outside temperature has occurred which would cause Circulating Water inlet temperature to drop to ≤ 36°F, THEN enter QCOP 0010-02. IF outside air temperature is ≥ 95°F, THEN enter QCOP 0010-10.
- c. (Unit 2 Only)  
Once per shift, verify Control Room air temperature is ≤ 95°F from either of the following:
- (1) Panel 912-5, TI 1/2-5795-8B CR AIR TEMP.
  - (2) On wall behind Panel 902-8, TIC 0-5795-359 CONTROL RM HVAC "B" TRAIN BYPASS DAMPER THERMOSTAT.

48. Spent Fuel Storage Pool Water Level. (Required during movement of irradiated fuel assemblies in the spent fuel storage pool or during movement of new fuel assemblies in the spent fuel storage pool with irradiated fuel assemblies seated in the spent fuel storage pool.)

TS 3.7.8

The spent fuel storage pool water level shall be  $\geq$  19 ft over the top of irradiated fuel assemblies seated in the spent fuel storage racks. This corresponds to approximately 4 feet below the "0" mark on the level indicator.

Daily, record fuel pool level. Verify level is between +1" and -2". The "0" mark on the level indicator in the fuel pool equals 37' 9".

49. RVLIS Backfill. (Perform in MODES 1, 2, 3 and prior to entering required mode.)

Once per day, record readings obtained from RVLIS flow indicators FI 1(2)-0263-164A, 165A, 164B, and 165B per QCOS 0201-09. Verify all flows are  $\geq$  0.45 AND  $\leq$  0.75 gph.

50. MSL High Flow. (Required in MODES 1, 2, 3 and prior to entering required mode.)

TS 3.3.6.1  
TS 3.3.7.1

Once per shift, record MSL dP readings obtained from Analog Trip System Panels 2201(2)-73A, -73B, -73AA, and -73BB). Verify the four readings for each steam line are within 16 psid of each other. Perform CHANNEL CHECK once per shift.

MSL A:	261 A-D	MSL B:	261 E-H
MSL C:	261 J-M	MSL D:	261 N-S

51. Core Spray Differential Pressure Instrumentation.

Once per day with fuel in vessel and prior to start up from a cold condition, record differential pressures obtained from DPI 1459A and B on the 2201-7 (2202-8) rack. Verify readings are  $<$  1 psid.

- (8) Demonstrate direct communications between Control Room and Refueling Platform personnel once within one hour prior to start of CORE ALTERATIONS and then once per shift thereafter, except movement of control rods with their normal drive system.
  - (9) Verify an OPERABLE fully inserted SRM detector reading  $\geq 3$  cps or  $\geq 0.7$  cps with a signal to noise ratio  $\geq 20:1$  is located in the fueled region of the core quadrant where CORE ALTERATIONS are being performed, when the associated SRM is included in the fueled region and another is located in an adjacent quadrant to where CORE ALTERATIONS are being performed, when the associated SRM is included in the fueled region within 12 hours prior to start of CORE ALTERATIONS or control rod withdrawal and then once per shift.  
(Note: The cps requirement is NOT required to be met with less than or equal to four fuel assemblies adjacent to the SRM and NO other fuel assemblies in the associated core quadrant.) Verify signal to noise determination QCIS 0700-09 complete within 31 days prior to start of CORE ALTERATIONS and then at least once per 31 days.
  - (10) Verify all control rods fully inserted when loading fuel assemblies into the core once per shift.
  - (11) Verify each withdrawn control rod accumulator pressure is  $\geq 940$  psig once per 7 days and insert each withdrawn control rod at least one notch once per 7 days. NOT applicable to control rods removed per TS 3.10.5.
53. Reactor Mode Switch Interlock Testing. (Required in MODES 3 and 4 with the reactor mode switch in the run, startup/hot standby, or refuel position AND required in MODE 5 with the reactor mode switch in the run or startup/hot standby position.) (IF NOT in correct mode, THEN leave blank.)
- TS 3.10.1
- a. Once per shift, verify all control rods are fully inserted in core cells containing one or more fuel assemblies. This must be verified by a second licensed Operator (RO or SRO) or other task qualified member of the Technical Staff (STA or RE).
  - b. Once per shift, verify NO CORE ALTERATIONS are in progress.

56. HI-STORM Fuel Casks [required during STORAGE OPERATIONS (spent fuel in casks)].

TS 3.1.2, Technical Specifications for the HI-STORM 100 Cask System.

HI-STORM FSAR Table 9.1.2.

Daily, verify all OVERPACK inlet and outlet air ducts are free of blockage and gross damage to vent duct screens. IF any blockage can NOT be removed within the TS Action Statement specified time, THEN enter QCFHP 0800-05.

57. Surveillance items 1 through 55 complete.

The Operator shall record the time surveillance items 1 through 54 have been completed. (B.1)

58. SBO DG Room Temperatures.

Shiftly, record Engine Room and Electrical Equipment Room temperatures as indicated on the DCS Panel or obtained locally. Verify temperatures are between 60°F and 95°F. Expected temperatures in the SBO Rooms during and immediately after an SBO event could be as low as 40°F or as high as 125°F. (B.4)

- a. IF < 95°F, THEN record temperatures.
- b. IF > 95°F, THEN:
  - (1) IF in SBO DG Room, THEN verify 1(2)-5790-6001 fan is running.
  - (2) Indicate that SBO DG Room is < 5% Lower Explosive Limit by Radiation Protection sample OR start additional SBO DG Room ventilation fans.
  - (3) IF in SBO Electrical Equipment Room, THEN verify 1(2)-5790-6004 fan is running.
- c. IF > 99°F in SBO Electrical Equipment Room, THEN verify 1(2)-5790-6005 fan is running.

64. HPCI Room Temperature. (Required in MODES 1 and 2, and MODE 3 with Reactor Pressure > 150 psig and prior to entering required MODE/condition.)

Daily, record HPCI Room temperature. IF room temperature is greater than or equal to 100 deg F, THEN initiate shiftly monitoring, notify US, and take action to restore room cooling. IF room temperature is greater than or equal to 108 deg F, THEN initiate IR and contact Engineering to aid in operability determination. Verify temperature does NOT exceed 120°F.

65. Stack and Metro Tower Lights.

Daily, verify Stack and Metro Tower within Owner Controlled area lights are lit.

For the Stack (Main Chimney): to maintain FAA required illumination, a maximum of four lights may be lost from any bank, or any combination of banks. (B.13.)

Information in the following table can be used for Reportability Manual LS-AA-1110 Reportable Events SAF 1.18, malfunction of FAA Required Lights, and SAF 1.28, Restoration of FAA Required Lights. Clinton, IA Airport (CWI) is 7 miles North of the station.  
FAA phone number: 877-487-6867

Tower	FCC Registration #	Latitude	Longitude	Height above mean sea level	Height above ground
MAIN CHIMNEY	N/A	41°43m 46s North	90° 18m 40.2s West	275.8 m 905 ft	94.5 m 310 ft
NORTH MET	1252238	41°42m 46.3s North	90° 18m 31s West	307.5 m 1009 ft	121.9 m 400 ft
SOUTH MET	1253646	41°43m 45s North	90° 18m 22.5s West	276.1 m 906 ft	91.4 m 300 ft

(2) For Unit 2:

- Amp Meter on Panel 902-8, XFMR 22 TO BUS 21 AND BUS 22 CUR/PH B OR Computer Point E206, XFMR 22 FD TO BUS 21/22.
- Amp Meters on Panel 902-8, the sum of XFMR 22 TO BUS 23 CUR/PH B plus XFMR 22 TO BUS 24 CUR/PH B.

Required once per shift while Generator is on line, check that TR 11(21) and TR 12(22) amps are normal OR refer to QCOP 6500-09 to return transformer load to normal.

67. Heat Balance Parameters.

Once per eight-hours WHEN Reactor power is  $\geq 75\%$ , perform QCOS 0005-10.

68. Steam Dryer Monitoring Plan

Steam - Feedwater Flow Mismatch monitoring frequency once/hour. IF unexplained change  $\geq 0.2$  Mlbm/hr from existing condition, THEN initiate an IR and notify Engineering for evaluation.

Main Steam Line Flow monitoring frequency once/hour. IF unexplained change  $\geq 0.15$  Mlbm/hr, THEN initiate an IR and notify Engineering for evaluation.

Reactor Water Level monitoring frequency once/hour. IF unexplained change of +/- 3 inches, THEN initiate an IR and notify Engineering for evaluation.

Reactor Pressure monitoring frequency once/hour. IF unexplained change of +/- 2 psig, THEN initiate an IR and notify Engineering for evaluation.

Moisture Carryover monitoring frequency once/week. IF exceeds 0.3%, THEN initiate an IR and perform confirmatory sample. The IR should assess for potential structural degradation of the steam dryer.

69. Protected Equipment Signs.

Once per 8 hours when Protected Equipment signs are posted, per OP-AA-108-117. Using the Protected Equipment Operator Aid, verify all required Posted Protected Equipment signs are in place. Ensure NO unauthorized work on or within 2 feet of the Protected Equipment.

72. DVR (Data Validation and Reconciliation) Correction Factor Validation.

Twice per shift, validate installed DVR Feedwater Flow Correction Factors by ensuring specified Secondary Plant Parameters are within expected ranges. This should be performed per QCOP 9950-18 Step F.4.

IF DVR Correction Factors are disabled (value of 1.00 for all three FW Pump correction factors), THEN all parameters will indicate ACCEPTABLE 'In Band' on the 'Secondary Parameters Monitoring' PPC screen, and a check may be placed in the box indicating that correction factors were validated to be disabled.

WHEN CTP is < 85%, DVR Correction Factors are required to be disabled (ref. QCGP 3-1), so this check additionally confirms that the DVR Correction Factors are set to 1.00 for this condition.

The Secondary Plant Parameters monitored are Turbine 1<sup>st</sup> Stage Pressure via Computer Point DEHC\_A017\_AVG, High Pressure Turbine Exhaust Pressure via Computer Point T102\_AVG(not applicable for Unit 2), and average Feedwater Temperature via Computer Point D168\_AVG(D268\_AVG). The value of the parameter must fall between the upper and lower bounds specified below (check normally performed automatically by PPC). IF the value is outside of the specified band, THEN follow the guidance of QCOP 9950-18 step F.4. It is not expected that the DVR Correction Factors will be utilized when the PPC is not functional, therefore hand-calculation of limits and comparison to actual parameter values is not anticipated. The limits, which are only applicable above 85% CTP, are included here for informational purposes.

U1 Turbine 1<sup>st</sup> Stage Pressure, DEHC A017

Upper Limit: CTP (MWth) \* 0.293936 - 51.156178

Lower Limit: CTP (MWth) \* 0.293936 - 66.521022

U1 HP Turbine Exhaust Pressure, T102

Upper Limit: CTP (MWth) \* 0.10606 - 36.304297

Lower Limit: CTP (MWth) \* 0.10606 - 40.713903

U2 Turbine 1<sup>st</sup> Stage Pressure, DEHC A017

Upper Limit: CTP (MWth) \*0.299438 - 73.681556

Lower Limit: CTP (MWth) \*0.299438 - 85.773692

U1 Average Feedwater Temp, D168

Upper Limit: CTP (MWth) \*0.022041 + 288.947002

Lower Limit: CTP (MWth) \*0.022041 + 287.544798

79. Itemized Scheduled Surveillance Incomplete.

Any items NOT completed during their designated time interval are to be itemized and carried forward to the next shift. The Unit Supervisor shall determine IF a Tech Spec required time interval has been exceeded.

80. All Scheduled Surveillances Complete.

Upon completion of a set of readings, Unit Supervisor shall review their shift's surveillance, verify surveillance items 1 through 54 were completed by 0500 for Set 1, by 1300 for Set 2 and by 2100 for Set 3, list any discrepancies, and initial appropriate block.

81. Review Previous Shift Surveillance.

The oncoming Unit Supervisor shall review the previous shift surveillance taking particular note of any surveillance listed as incomplete and initial the previous shift surveillance.

G. CHECKLISTS

1. QOS 0005-S01, Operations Department Weekly Summary of Daily Surveillance Unit \_\_\_\_.

H. TECHNICAL SPECIFICATION REFERENCES

1. References included in procedure body.

**Job Performance Measure****Verify SSMP Post Test Standby Lineup**JPM Number: RO A1.2Revision Number: 00Date: 02/01/2024Developed By: \_\_\_\_\_  
Instructor: Print / Sign \_\_\_\_\_ Date \_\_\_\_\_Reviewed By: \_\_\_\_\_  
SME or Instructor: Print / Sign \_\_\_\_\_ Date \_\_\_\_\_Reviewed By: \_\_\_\_\_  
Operations Representative: Print / Sign \_\_\_\_\_ Date \_\_\_\_\_Approved By: \_\_\_\_\_  
Training Department: Print / Sign \_\_\_\_\_ Date \_\_\_\_\_

## JOB PERFORMANCE MEASURE VALIDATION CHECKLIST

**NOTE:** All steps of this checklist should be performed upon initial validation.  
Prior to JPM usage, revalidate JPM using steps 9 and 13 below.

1. Task description and number, JPM description and number are identified. \_\_\_\_\_
  2. Knowledge and Abilities (K/A) references are included. \_\_\_\_\_
  3. Performance location specified. (in-plant, control room, simulator, or other) \_\_\_\_\_
  4. Initial setup conditions are identified. \_\_\_\_\_
  5. Initiating cue (and terminating cue if required) are properly identified. \_\_\_\_\_
  6. Task standards identified and verified by instructor or SME review. \_\_\_\_\_
  7. Critical steps meet the criteria for critical steps and are identified with an asterisk (\*). \_\_\_\_\_
  8. IAW NUREG 1021 Appendix C, clearly identify the task standard (i.e., the predetermined qualitative or quantitative outcome) against which task performance will be measured. \_\_\_\_\_
  9. Verify the procedure(s) referenced by this JPM reflects the current revision: \_\_\_\_\_
- |            |   |           |       |
|------------|---|-----------|-------|
| Procedure: | QCOS 2900-01, SAFE SHUTDOWN MAKEUP PUMP FLOW RATE<br>TEST | Revision: | 43    |
| Procedure: | _____   | Revision: | _____ |
| Procedure: | _____   | Revision: | _____ |
10. Verify cues both verbal and visual are free of conflict. \_\_\_\_\_
  11. Verify performance time is accurate. \_\_\_\_\_
  12. If the JPM cannot be performed as written with proper responses, then revise the JPM. \_\_\_\_\_
  13. When JPM is initially validated, sign and date JPM cover page. For subsequent validations, sign and date below: \_\_\_\_\_

\_\_\_\_\_/\_\_\_\_\_  
SME / Instructor (Print/Sign) \_\_\_\_\_ Date

\_\_\_\_\_/\_\_\_\_\_  
SME / Instructor (Print/Sign) \_\_\_\_\_ Date

\_\_\_\_\_/\_\_\_\_\_  
SME / Instructor (Print/Sign) \_\_\_\_\_ Date

**Revision Record (Summary)**

<b>Revision #</b>	<b>Summary</b>
00	New JPM developed for the 2024 ILT NRC Exam IAW NUREG 1021 Rev. 12, Section ES-3.2, D.

### **SIMULATOR SETUP INSTRUCTIONS**

1. Reset the simulator to IC-20 (75% power).

**NOTE:** It is okay to use a similar IC to the IC listed above, provided the IC actually used is verified to be compatible with this and other JPMs that are scheduled to be run concurrently.

2. Procedures required for JPM performance:

Marked up copy of QCOS 2900-01, Safe Shutdown Makeup Pump Flow Rate Test as follows:

- Step D.1 – check Normal Surveillance
- Sign off all remaining steps up to H.22
- Steps H.10.b, H.11, and H.14.b. are N/A
- Obtain most recent surveillance from EDMS for plant data.

3. Manual Actions:

- Place the SSMP Controller in MANUAL with setpoint at 250 gpm.
- Open the MO 1/2-2901-7 valve until it has dual indication.

4. This completes the setup for this JPM.

### INITIAL CONDITIONS

- You are the U-2 Extra NSO.
- QCOS 2900-01, SAFE SHUTDOWN MAKEUP PUMP FLOW RATE TEST has been completed up to step H.22.
- The U-1 Supervisor has directed you to perform an independent verification of the standby lineup per QCOS 2900-01 step H.22.
- This JPM is NOT time critical.

### INITIATING CUE

Verify the SSMP standby lineup per QCOS 2900-01 step H.22.  
Inform the Unit Supervisor of any discrepancies.

**Provide examinee with:** Copy of QCOS 2900-01, SAFE SHUTDOWN MAKEUP PUMP FLOW RATE TEST marked up as described in setup.

Fill in the JPM Start Time when the student acknowledges the Initiating Cue.  
.....

#### Information For Evaluator's Use:

UNSAT requires written comments on respective step.

\* Denotes critical steps.

Number any comments in the "Comment Number" column on the following pages. Then annotate that comment in the "Comments" section. The comment section should be used to document: the reason that a step is marked as unsatisfactory, marginal performance relating to management expectations, or problems the examinee had while performing the JPM. Comments relating to procedural, or equipment issues should be entered and tracked using the site's appropriate tracking system.

Some operations that are performed from outside of the control room may require multiple steps. These items may be listed as individual steps in this JPM. It is acceptable for the candidate to direct the local operator to perform groups of procedure steps instead of calling for each individual item to be performed.

The timeclock starts when the candidate acknowledges the initiating cue.  
.....

JPM Start Time: \_\_\_\_\_ JPM Sequence #: \_\_\_\_\_ of \_\_\_\_\_

<b><u>Task Standard:</u></b>					
Perform a verification of the SSMP standby lineup and identify the SSMP Flow Controller setpoint and the MO 1/2-2901-7 valve position requirements are NOT met using QCOS 2900-01 and report these discrepancies to the Unit Supervisor.					
<b><u>STEP</u></b>	<b><u>ELEMENT</u></b>	<b><u>STANDARD</u></b>	<b>SAT</b>	<b>UNSAT</b>	<b>Comment Number</b>
Step H.22.a.	Verify MO 1/2-2901-6 valve is open.	At the 912-8 panel: <ul style="list-style-type: none"> <li>- Digital indication at the bottom of FIC 0-2940-7 is reading <math>\geq 7\%</math>.</li> <li>- Initials step.</li> </ul>	<input type="checkbox"/>	<input type="checkbox"/>	—
<b>CUE:</b>	<b>If the examinee attempts to dispatch an EO to determine valve position locally, state:</b> <b>“There are presently no extra EOs available at this time.”</b>				
*Step H.22.a.	Verify MO 1/2-2901-7 valve is closed.	At the 912-8 panel: <ul style="list-style-type: none"> <li>- Observes both OPEN and CLOSED lights for the 1/2-2901-7 valve are LIT.</li> <li>- *Determines the 1/2-2901-7 valve is NOT fully closed.</li> <li>- Does NOT initial step.*</li> </ul>	<input type="checkbox"/>	<input type="checkbox"/>	—
Step H.22.a.	Verify FIC 1/2-2940-7 is in MANUAL mode.	At the 912-8 panel: <ul style="list-style-type: none"> <li>- On FIC 0-2940-7, observes (  ) is lit above Auto/Man pushbutton.</li> <li>- Determines FIC 1/2-2940-7 is in MANUAL mode.</li> <li>- Initials step.</li> </ul>	<input type="checkbox"/>	<input type="checkbox"/>	—

<u>STEP</u>	<u>ELEMENT</u>	<u>STANDARD</u>	<b>SAT</b>	<b>UNSAT</b>	<b>Comment Number</b>
*Step H.22.a.	Verify FIC 1/2-2940-7 setpoint is at 200 gpm.	At the 912-8 panel: <ul style="list-style-type: none"> <li>- *On FIC 0-2940-7, observes value indicated at the bottom of the scale is 250.</li> <li>- Does NOT initial step.*</li> </ul>	<input type="checkbox"/>	<input type="checkbox"/>	—
*	Reports discrepancies to the U-1 Supervisor.	Informs the U-1 Supervisor of following: <ul style="list-style-type: none"> <li>- MO 1/2-2901-7 valve is NOT in the required closed position.</li> <li>- FIC 1/2-2940-7 setpoint needs to be adjusted to 200 gpm.</li> </ul>	<input type="checkbox"/>	<input type="checkbox"/>	—
<b>CUE:</b>	<b>As the Unit Supervisor, state:</b> <b>“The U-1 Extra NSO will make the required corrections and another operator will re-perform the verification.”</b>				
<b>EVALUATOR NOTE: The examinee should inform you the task is complete.</b>					

JPM Stop Time: \_\_\_\_\_

.....

**JPM SUMMARY**
**Operator's Name:** \_\_\_\_\_ **Emp. ID#:** \_\_\_\_\_

**Job Title:**  EO  RO  SRO  FS  STA/IA  SRO Cert

**JPM Title:** Verify SSMP Post Test Standby Lineup

**JPM Number:** RO A1.2

**Revision Number:** 00

Task Number and Title: SR-2900-P01 (Freq: LIC=B) Given a reactor plant cold shutdown with the SSMP in a standby lineup, perform the SSMP RPV injection test and return the system to a standby lineup from panel 912-8 in accordance with QCOS 2900-04 and QCOS 2900-01.

**Task Standard:** Perform a verification of the SSMP standby lineup and identify the SSMP Flow Controller setpoint and the MO 1/2-2901-7 valve position requirements are NOT met using QCOS 2900-01 and report these discrepancies to the Unit Supervisor.

**K/A Number and Importance:** **K/A:** 2.1.31

**Rating:** RO/SRO 4.6/4.3

**Suggested Testing Environment:** Simulator

**Alternate Path:**  Yes  No **SRO Only:**  Yes  No **Time Critical:**  Yes  No

**Reference(s):**

Procedure:	QCOS 2900-01, SAFE SHUTDOWN MAKEUP PUMP FLOW RATE	Revision:	<u>43</u>
Procedure:	TEST	Revision:	_____
Procedure:	_____	Revision:	_____

**Actual Testing Environment:**  Simulator  Control Room  In-Plant  Other

**Testing Method:**  Simulate  Perform

**Estimated Time to Complete:** 5 minutes

**Actual Time Used:** \_\_\_\_\_ minutes

**EVALUATION SUMMARY:**

 Were all the Critical Elements performed satisfactorily?  Yes  No

 The operator's performance was evaluated against standards contained within this JPM and has been determined to be:  Satisfactory  Unsatisfactory

**NOTE:** Enter finalized grading, comments, and notes relevant to this evaluation in the associated TQ-AA-150-F03A/B. (See AR [4282419](#)).

**Evaluator's Name (Print):** \_\_\_\_\_

**Evaluator's Signature:** \_\_\_\_\_ **Date:** \_\_\_\_\_

**Page Intentionally Left Blank**

### **INITIAL CONDITIONS**

- You are the U-2 Extra NSO.
- QCOS 2900-01, SAFE SHUTDOWN MAKEUP PUMP FLOW RATE TEST has been completed up to step H.22.
- The U-1 Supervisor has directed you to perform an independent verification of the standby lineup per QCOS 2900-01 step H.22.
- This JPM is NOT time critical.

### **INITIATING CUE**

Verify the SSMP standby lineup per QCOS 2900-01 step H.22.

Inform the Unit Supervisor of any discrepancies.

## SAFE SHUTDOWN MAKEUP PUMP PUMP FLOW RATE TEST

### ~~A.~~ PURPOSE

To perform periodic testing of the Safe Shutdown Makeup System pump and valves from MCR Panel 912-8, as required by the Inservice Testing (IST) Program, Technical Specification 3.7.9, and Appendix R

### ~~B.~~ DISCUSSION

~~B.1.~~ This procedure has been written to accommodate the following IST pump test:

~~a.~~ IST Group B Pump Test: A quarterly test that monitors pump flow rate and differential pressure. Special 0.5% accurate instrumentation may be used to monitor inlet and discharge pressures.

~~B.2.~~ The following safety related components and IST test requirements are accountable to this procedure:

#### ~~a.~~ EXERCISE OPEN

~~(1)~~ 1/2-2901-4, SAFE SHUTDOWN MU PMP DSCH CK VLV.

~~(2)~~ 1/2-2901-5, SAFE SHUTDOWN MU PMP RECIRC CK VLV.

#### ~~b.~~ IST GROUP B PUMP TEST

~~(1)~~ 1/2-2901, SAFE SHUTDOWN MAKEUP PUMP.

~~B.3.~~ QCOS 2900-03 may be performed in conjunction with this procedure.

~~B.4.~~ Local valve operations and indications are in the SSMP Room at Turbine Building ground floor of Unit 2 by the Cardox unit.

~~B.5.~~

The open function of 1(2)-2901-10, SAFE SHUTDOWN PMP TO U1(2) HPCI DSCH CK VLV, is required for operability of SSMP, and the close function is required for operability of HPCI. The check valve is designed to check flow but is **NOT** designed to be a pressure isolation valve. For this reason, a pressure increase is sometimes observed on the discharge of the SSMP subsequent to opening MO 1(2)-2901-08, U1(2) REACTOR SUPPLY VLV. This is not unexpected and does **NOT** render HPCI inoperable (reference AT 370284-04). An Issue Report should be written to address operability if concern still exists.

~~B.6.~~

This procedure is used to verify pressure and flow requirements of the SSMP for both Tech Specs and Appendix R. These requirements were determined in Calculation QDC-2900-M-0472, Rev. 001. (J.8.e)

~~a.~~

To meet the pressure and flow requirement for Tech Spec 3.7.9, a test performed at 400 gpm is required.

~~b.~~

**IF** discharge pressure of  $\geq 1264.0$  psig at 400 gpm is achieved, **THEN** acceptance criteria needed for both Tech Specs and Appendix R are met.

~~c.~~

**IF** a SSMP discharge pressure of  $\geq 1264.0$  psig at 400 gpm can **NOT** be achieved, **THEN** the Appendix R pressure criteria will be verified when the SSMP is set to 300 gpm.

~~B.7.~~

Contaminated Condensate Storage Tank (CCST) Level Correction. (J.8.e)

When a measurement is taken during this surveillance, a correction factor will be needed to be subtracted from the acquired SSMP discharge pressure to compare it to the required discharge pressure. This correction factor is a combination of the sum of the uncertainties in the pressure instruments and a correction factor for the CCST level at the time of the surveillance.

~~B.7~~ (cont'd)

~~a~~ Tech Spec CCST Level Correction Factor ( $P_{Tscorr}$ )

During a Tech Spec event, it is assumed that the minimum amount of water is in the CCST for the entire event.

Therefore, the Tech Spec CCST Level Correction Factor is calculated using:

$$P_{Tscorr} = 6.02 + (0.44 * \text{CCST Level})$$

~~b~~ Appendix R CCST Level Correction Factor ( $P_{Rcorr}$ )

During an Appendix R event, the water in the CCST will be located at the top of the standpipes since the 300 gpm requirement is at the beginning of the event only. This is due to the boil off rate in the reactor changing as the decay heat lowers. Therefore, less water will be required further into the event and the added column of water (8.4 ft) can be added to the pressure correction factor. This 8.4 feet of margin is subtracted from the CCST water level resulting in the following calculation for the Appendix R CCST Level Correction Factor:

$$P_{Rcorr} = 6.02 + [0.44 * (\text{CCST Level} - 8.4)]$$

~~B.8~~

SSMP operation with the Flow Control Valve (FCV) in MANUAL may be necessary if FCV oscillations occur in AUTO. Due to SSMP being a manual start system, automatic operation of the FCV is not required for system operability.

### ~~C.~~ EQUIPMENT REQUIRED

~~C.1~~

High-pressure hose to connect temporary digital discharge pressure gauge.

~~C.2.~~ Temporary digital pressure gauge that meets the following requirements:

Parameter	Range	Accuracy
Discharge Pressure	0-2000 psig	+ 0.5% of calibrated range (or more accurate)

~~C.3.~~ **IF** performing an IST Group B Pump test using temporary digital inlet pressure gauge, **THEN**:

Parameter	Range	Accuracy
Inlet Pressure	0-15 <b>OR</b> 0-30 psig	+ 0.5% of calibrated range (or more accurate)

~~D.~~ **PREREQUISITES**

~~D.1.~~ Unit Supervisor has completed the following:

~~a.~~ Reason for test (check appropriate item):

Normal Surveillance (✓)

~~NOTE~~

**IF** this is a Post-Maintenance test for the SSMP Pump, **THEN perform** QCOS 2900-08.

Post Maintenance ( )

Partial for \_\_\_\_\_ ( )

Other ( )

~~b.~~ Permission to start test:

\_\_\_\_\_  
*Unit Supervisor*  
 US Signature

*current* / *current*  
 Date / Time

~~D.2.~~ SSMP System in standby lineup per QCOP 2900-01 with suction from CCST.

ADJ

~~D.3.~~ Oil level visible in SSMP pump and motor oilers.

EO/MSO

~~D.4~~ Appropriate IST Pump Test Acceptance Criteria Sheet with IST Acceptable, Alert, and Required Action Range data is attached to this procedure. NOT

~~D.5~~ **Record** ID numbers and calibration due date for instruments to be used:

Instrument	Range	ID Number	Cal Due Date
Discharge Pressure	0-2000 psig	4407015	9/22/24

~~D.6~~ **IF** performing an IST Group B Pump Test using temporary digital inlet pressure gauge, **THEN** ID number and calibration due date recorded for instrument to be used:

Instrument	Range	ID Number	Cal Due Date
Inlet Pressure	0-15 psig <b>OR</b> 0-30 psig	4384031	9/21/24

~~D.7~~ **Direct** Instrument Maintenance (IMD) to install the following:

~~1.~~ **Install** a digital pressure instrument (range: 0-2000 psig) downstream of 1/2-2941-8A, SSMP PI 0-2941-08 DISCHARGE PRESSURE INDICATOR CALIBRATION VALVE.

(1) **Verify closed AND uncap** 1/2-2941-8A. IM1

(2) **Install** temporary digital pressure instrument using high-pressure hose

Installed by: IM1 Date: current

Verified by: IM2 Date: current

(3) **Open** 1/2-2941-8A. IM1

Verified by: IM2

~~D.7~~ (cont'd)

~~(b)~~ **IF** performing an IST Group B Pump Test using temporary digital inlet pressure gauge, **THEN install** a digital pressure instrument (range: 0-15 psig or 0-30 psig) downstream of 1/2-2941-1A, SSMP PI 0-2941-1 SUCTION PRESSURE INDICATOR CALIBRATION VALVE:

~~(1)~~ **Verify closed AND uncap** 1/2-2941-1A. IM1

~~(2)~~ **Install** temporary digital pressure instrument:

Installed by: IM1 Date: CURRENT

Verified by: IM2 Date: CURRENT

~~(3)~~ **Open** 1/2-2941-1A. IM1

Verified by: IM2

~~D.8.~~ **Verify** 1/2-2901-6, SAFE SHUTDOWN MU PMP FCV, is set to ensure a minimum flow path for SSMP. (SSMP will trip if FCV 1/2-2901-6 is closed.):

~~(a)~~ Controller in MANUAL ( $\leq 20$  lit). ASO

~~(b)~~ Controller flow setpoint at 200 gpm (value at bottom of scale indicates 200). ASO

~~(c)~~ Valve position to  $\geq 7\%$  open (value at bottom of controller indicates  $\geq 7$ ) ASO

~~D.9.~~ **Record** CCST levels:

~~(a)~~ A CCST LVL (1/2-3340-3) 15 ft

~~(b)~~ B CCST LVL (1/2-3340-4) 15 ft

~~(c)~~ **Record** the higher CCST level. 15 ft

~~D.9~~ (cont'd)

d. **Calculate** Tech Spec CCST Level Correction Factor ( $P_{TScorr}$ ) from the HIGHER CCST level: (J.8.e)

$$P_{TScorr} = 6.02 + (0.44 * \frac{15 \text{ ft}}{\text{CCST Level}})$$

$$P_{TScorr} = \underline{12.62} \text{ psig}$$

Performed By: MSD

Verified By: ANSD

~~D.10~~ **Calculate** the Appendix R CCST Level Correction Factor ( $P_{ARcorr}$ ) from the HIGHER CCST level: (J.8.e)

$$P_{ARcorr} = 6.02 + [0.44 * (\frac{15 \text{ ft}}{\text{CCST Level}} - 8.4)]$$

$$P_{ARcorr} = \underline{8.92} \text{ psig}$$

Performed By: MSD

Verified By: ANSD

~~E.~~ **PRECAUTIONS**

- ~~E.1.~~ Injection of SSMP into the Reactor during power operation could cause a reactivity transient.
- ~~E.2.~~ Continuous operation of the SSMP at flow rates < 150 gpm can damage the pump.
- ~~E.3.~~ Ensuring a pump discharge path will prevent overheating and subsequent damage to the SSMP by maintaining FCV 1/2-2901-6 open in conjunction with one of the following:
  - ~~a.~~ MO 1-2901-8, U1 REACTOR SUPPLY VLV.
  - ~~b.~~ MO 2-2901-8, U2 REACTOR SUPPLY VLV.
  - ~~c.~~ MO 1/2-2901-7, THROTTLED TEST VLV.

~~F.~~ **LIMITATIONS AND ACTIONS**

- ~~F.1.~~ Tech Spec Operability of the SSMP System pump and valves must be demonstrated from the MCR Panel 912-8. For IST purposes, pump inlet and discharge pressures will be read in the SSMP room.
- ~~F.2.~~ Appendix R availability is based on the ability to make up water to the RPV using the controls at local Panel 1/2-2251-104 and Control Room Panel 912-8.
- ~~F.3.~~ At the completion of the surveillance, the Unit Supervisor must immediately review the results of this test for compliance to Acceptance Criteria requirements.
- ~~F.4.~~ The SSMP can **NOT** be started unless one of the following is open:
- ~~A.~~ MO 1-2901-8.
  - ~~B.~~ MO 2-2901-8.
  - ~~C.~~ MO 1/2-2901-7.
- ~~F.5.~~ MO 1-2901-8 **AND** MO 2-2901-8 are interlocked so that one valve must be closed to open the other valve.
- ~~F.6.~~ **IF** a component fails to perform, **THEN** notify the Unit Supervisor.
- ~~F.7.~~ **IF** a selector switch is in LOCAL, **THEN** the corresponding control switch at Panel 912-8 will **NOT** affect the component.
- ~~F.8.~~ **IF** a selector switch is in MCB, **THEN** the corresponding control switch at Panel 2251-104 will **NOT** affect the component.
- ~~F.9.~~ **IF** a selector switch at Panel 2251-104, Safe Shutdown System local control panel, is placed in LOCAL, **THEN** indication and control of that component is lost in the Control Room **AND** Panel 912-8 annunciator A-8 will alarm.

~~NOTE~~

The following guidelines do **NOT** apply to MO 1/2-2901-6. (J.8.d)

~~F.10~~ For Motor Operated Valves Guidelines see OP-AA-103-105. (J.5.a)

~~F.11~~ SSMP Motor Start Limitations:

~~(a.)~~ Surveillance or testing conditions:

~~(1)~~ At ambient temperatures (up to 40°C or 104°F), the motor can make 2 starts in succession after coasting to rest between starts. After 2 starts, the motor should be allowed a 30-minute cooling off period before subsequent starts.

~~(2)~~ At normal operating temperatures (after running with motor coupled to the pump), the motor can make 1 restart, with a 30-minute cooling off period before subsequent starts.

~~(a)~~ **IF** the motor is run uncoupled, **THEN** the cooling off period can be reduced to 10 minutes.

~~(b.)~~ Emergency conditions:

~~(1)~~ Motor nameplate ratings allow 7 starts with the motor initially at ambient temperatures (up to 40°C or 104°F), and 4 starts with the motor initially at rated load operation temperatures, before a 30-minute cooling off period is recommended.

~~F.12~~ **IF** partial testing is required, **THEN** the Unit Supervisor will document in the PREREQUISITES either the steps to be performed **OR** the steps to be disregarded, **AND** any special instructions required for performance of the partial test.

- ~~F.13.~~ The SSMP System shall be demonstrated OPERABLE at least once per 92 days by verifying that the SSMP develops a flow of  $\geq 400$  gpm against a system head corresponding to Reactor vessel pressure of  $> 1120$  psig. (J.1.a)
- ~~F.14.~~ The following sections may be performed any time after the appropriate step is completed, but must be completed before final acceptance of this procedure.
  - ~~a.~~ Acceptance Criteria verification.
  - ~~b.~~ Calculation verification.
  - ~~c.~~ Vibration amplitude tables (if performed).

## ~~G.~~ **PERFORMANCE ACCEPTANCE CRITERIA**

- ~~G.1~~ The SSMP, in AUTO or MANUAL flow control, developed a flow rate of  $> 400$  gpm at a discharge pressure  $> 1215.0$  psig (discharge pressure corresponding to Reactor pressure of  $> 1120$  psig). (J.1.a, J.8.e)
  - ~~G.2~~ For Appendix R, the SSMP, in AUTO or MANUAL FCV operation:
    - ~~a.~~ Developed a flow rate of  $> 400$  gpm at a discharge pressure  $> 1264.0$  psig. (J.8.e)
- OR**
- ~~b.~~ Developed a flow rate of  $> 300$  gpm at a discharge pressure  $> 1233.4$  psig. (J.8.e)
- ~~G.3~~ **IF** performing an IST Comprehensive Pump Test, **THEN** SSMP differential pressure **AND** vibration are within IST Acceptable Range. (N/A, IF setting baseline)
  - ~~G.4~~ Check valves 1/2-2901-4 and 1/2-2901-5 are verified to have opened by the pump meeting discharge flow  $> 400$  gpm.
  - ~~G.5~~ SSMP running inlet pressure was  $> 0$  psig (NPSH minimum). (J.8.g)

~~H.~~ **PROCEDURE**

- H.1. **Verify** annunciator 912-8 A-8, SAFE SHUTDOWN SYSTEM TROUBLE, is clear, indicating selector switches at local panel 2251-104 are in MCB. MSD

~~NOTE~~

Unless otherwise noted, all controls are located on MCR Panel 912-8. Inlet and discharge pressures will be read in the SSMP Room.

- H.2. **Open** MO 1/2-2901-7. MSD

- H.3. In SSMP Room, **close** 1/2-2999-9, SERVICE WATER TO SSMP ROOM COOLER BYPASS VALVE. EO/MSD

- H.4. **Start** 1/2-2901, SAFE SHUTDOWN PMP. MSD

- a. **Verify** PI 1/2-2940-05, PUMP DISCHARGE PRESSURE increases. MSD

- b. **IF** necessary, **THEN adjust** pump flow to approximately 200 gpm with flow controller FIC 1/2-2940-7 using ◀/▶ and monitoring flow value at top of scale. MSD

- ~~H.5.~~ **Verify** running pump inlet pressure meets NPSH minimum:

- a. **IF** using PI 1/2-2941-1 PMP 1/2-2901 SUCT PRESS to obtain SSMP Inlet Pressure, **THEN record** running pump inlet pressure from PI 1/2-2941-1. N/A/MSD

- ~~b.~~ **IF** using temporary digital inlet pressure gauge to obtain to obtain SSMP Inlet Pressure, **THEN record** running pump inlet pressure from temporary digital inlet pressure gauge. 4.5  
psig

~~H.5~~ (cont'd)

- c. **Verify** running inlet pressure  $\geq$  0 psig.  
(G.5)

NSO



**NOTE**

**IF** SSMP flow rate can **NOT** be maintained  $>$  150 gpm, **THEN** SSMP must be tripped.



SSMP flow rate must be  $\geq$  400 gpm to obtain accurate IST data.

It is preferred that flow controller FIC 1/2-2940-7 be operated in AUTO. **IF** SSMP flow rate can **NOT** be stabilized at a required flow with flow controller in AUTO, **THEN** it is acceptable to place flow controller in MANUAL for the purposes of collecting surveillance data.

The SSMP FCV will be returned to MANUAL as the final flow controller position prior to SSMP shutdown.



- H.6. **Place** FIC 1/2-2940-7 in auto by selecting the  pushbutton ( should be lit).

NSO

- H.7. **Slowly increase** flow setpoint using SP  /  until flow value at top of scale indicates 400 gpm.

NSO



- ~~H.8.~~ **Verify** proper operation of FIC 1/2-2940-7:

- a. **Lower** FIC 1/2-2940-7 setpoint using SP  /  until flow value at bottom of scale decreases from 400 to approximately 350 (gpm).

NSO









- (1) **Verify** corresponding flow reduction as indicated by flow value at top of scale.

NSO

- b. **Return** FIC 1/2-2940-7 setpoint to 400 gpm using SP  /  until flow value at bottom of scale increases to 400 (gpm).

NSO

~~H.8.b~~ (cont'd)

- (1) **Verify** corresponding flow increase as indicated by flow value at top of scale. NSO
- (c.) **Transfer** FIC 1/2-2940-7 to MANUAL (  lit) by selecting the  pushbutton NSO
- (d.) **Decrease** FIC 1/2-2940-7 signal to approximately 350 gpm using  /  until flow value at top of scale indicates 350. NSO
- (e.) **Increase** FIC 1/2-2940-7 signal to 400 gpm using  /  until flow value at top of scale indicates 400. NSO
- (f.) **Transfer** FIC 1/2-2940-7 to AUTO (  lit) by selecting the  pushbutton. NSO

~~H.9~~

**Record** the following data (used for trending purposes only):

PARAMETER	MEASURED
BUS 31 Voltage	<u>4200</u> volts VI-1/2-6700-07 (BUS 31 Cub 4)
SSMP motor current	<u>52.5</u> amps II-1-6041-0101B (BUS 31 Cub 1)
SSMP Running Inlet Pressure (P <sub>i</sub> )	<u>3.4</u> psig Digital Press Inst.
SSMP Motor Speed	<u>3585</u> RPM
FCV 1/2-2901-6 % open (Indicated at bottom of controller)	<u>8.0</u> %

**H.10** Establish flow and discharge pressure: N/A

**(a.)** Slowly increase flow setpoint using SP  $\nabla$ / $\blacktriangle$  until flow value at top of scale indicates as close as possible to, but **NOT** less than, 400 gpm while maintaining pump discharge pressure  $\geq$  1215.0 psig. N/A

**(b.)** IF SSMP flow rate can **NOT** be stabilized, THEN:

(1) Place FIC 1/2-2940-7 in MANUAL (  $\text{20}^{\text{m}}$  lit) by selecting the  $\square$  pushbutton. \_\_\_\_\_

(2) Slowly adjust flow using  $\blacktriangleleft$ / $\blacktriangleright$  until flow value at top of scale indicates as close as possible to, but **NOT** less than, 400 gpm while maintaining pump discharge pressure  $\geq$  1215.0 psig. N/A/N/A

~~NOTE~~

**WHEN** the required IST set point for flow rate has been established and before taking pressure data (as required), **THEN** pump flow rate shall be maintained as stable as the system permits for the following applicable durations:

IST Group B Test: No hold period.

~~NOTE~~

**IF** a SSMP discharge pressure of  $\geq$  1264.0 psig at 400 gpm, **THEN** acceptance criteria for both Tech Specs and Appendix R is met.

**IF** a SSMP discharge pressure of  $\geq$  1264.0 psig at 400 gpm can **NOT** be achieved, **THEN** Appendix R pressure criteria will be verified later in this test when the SSMP is set to 300 gpm.

H.11. **IF** using PI 1/2-2941-1 to obtain SSMP Inlet Pressure, **THEN record** the following and **verify** Acceptance criteria achieved:

PARAMETER	MEASURED	ACCEPTANCE CRITERIA	ACCEPTANCE CRITERIA PASS (Initial)
SSMP Discharge Flow	_____ gpm FIC 1/2-2940-7	≥ 400 gpm <b>AND</b> ≥ 1215.0 psig (G.1)	_____
SSMP Discharge Pressure (Pd)	_____ psig Digital Press Inst.		
Tech Spec CCST Level Correction Factor (PT <sub>scorr</sub> )	_____ psig (Step D.9)		
SSMP Corrected Discharge Pressure	_____ psig (Pd - PT <sub>scorr</sub> )		
SSMP Running Inlet Pressure (Pi)	_____ psig PI 1/2-2941-1	N/A	N/A
SSMP Differential Pressure (DP)	_____ psig (Pd - Pi)	IST Pump Test Acceptance Criteria Sheet (G.3)	_____
SSMP Total Head	_____ ft (DP x 2.31)	N/A	N/A

Calculations Performed by: \_\_\_\_\_

Verified by: \_\_\_\_\_

*N/A/MSO*

H.12. **IF** using temporary digital inlet pressure gauge to obtain SSMP Inlet Pressure, **THEN record** the following and **verify** Acceptance criteria achieved:

PARAMETER	MEASURED	ACCEPTANCE CRITERIA	ACCEPTANCE CRITERIA PASS (Initial)
SSMP Discharge Flow	<u>403</u> gpm FIC 1/2-2940-7	$\geq 400$ gpm <b>AND</b> $\geq 1215.0$ psig (G.1)	<u>MSO</u>
SSMP Discharge Pressure ( $P_d$ )	<u>1293</u> psig Digital Press Inst.		
Tech Spec CCST Level Correction Factor ( $P_{T_{corr}}$ )	<u>12.62</u> psig (Step D.9)		
SSMP Corrected Discharge Pressure	<u>1280</u> psig ( $P_d - P_{T_{corr}}$ )		
SSMP Running Inlet Pressure ( $P_i$ )	<u>3.1</u> psig Digital Press Inst.	N/A	N/A
SSMP Differential Pressure (DP)	<u>1289.9</u> psig ( $P_d - P_i$ )	IST Pump Test Acceptance Criteria Sheet (G.3)	<u>MSO</u>
SSMP Total Head	<u>2979.67</u> ft ( $DP \times 2.31$ )	N/A	N/A

Calculations Performed by: MSO

Verified by: MSO

a. **Verify** Appendix R SSMP flow rate of  $> 400$  gpm at a discharge pressure  $\geq 1264.0$  psig is met. (G.2) MSO

b. **Verify** check valves 1/2-2901-4 and 1/2-2901-5 are open by obtaining a SSMP flow of  $\geq 400$  gpm. (G.4) MSO

H.13. Verify FIC 1/2-2940-7 is in Auto (☉ lit). N/SO

H.14. Slowly adjust flow setpoint using SP ▼/▲ until flow value at top of scale indicates as close as possible to, but **NOT** less than 300 gpm. N/SO

a. **IF** SSMP flow rate can **NOT** be stabilized, **THEN:**

- (1) Place FIC 1/2-2940-7 in MANUAL (☿ lit) by selecting the ☑ pushbutton.
- (2) Slowly adjust flow using ◀/▶ until flow value at top of scale indicates as close as possible to, but **NOT** less than 300 gpm.

b. Record the following: N/A/N/SO

PARAMETER	MEASURED
SSMP Discharge Flow	<u>308</u> gpm FIC 1/2-2940-7
SSMP Discharge Pressure (Pd)	<u>1315</u> psig Digital Press Inst.
Appendix R CCST Level Correction Factor (PAR <sub>corr</sub> )	<u>8.92</u> psig (Step D.10)
SSMP Appendix R Corrected Discharge Pressure	<u>1306.08</u> psig (Pd - PAR <sub>corr</sub> )

Calculations Performed by: N/SO

Verified by: A/N/SO

c. Verify Appendix R SSMP flow rate of > 300 gpm at a corrected discharge pressure  $\geq$  1233.4 psig is met (G.3). N/SO

- ~~H.15~~ **Reduce** flow on FIC 1/2-2940-7:
- (a.) **IF** FIC 1/2-2940-7 is in AUTO (☉ lit), **THEN slowly adjust** flow setpoint using SP ▼/▲ until flow value at bottom of scale indicates 200. N/SO
  - (b.) **IF** FIC 1/2-2940-7 is in MANUAL (☒ lit), **THEN slowly adjust** flow setpoint using ◀/▶ until flow value at top of scale indicates 200. N/A/N/SO
  - (1) **Verify** setpoint at bottom of scale indicates 200. (Using SP ▼/▲ if adjustment necessary) N/A/N/SO
- H.16 **IF** FIC 1/2-2940-7 is in AUTO (☉ lit), **THEN place** in MANUAL (☒ lit) by selecting the  pushbutton. N/SO
- H.17 **Stop** 1/2-2901, SAFE SHUTDOWN PUMP. N/SO
- H.18 **Close** MO 1/2-2901-7. N/SO
- H.19 **Verify** annunciator 912-8 A-8, SAFE SHUTDOWN SYSTEM TROUBLE, is clear. N/SO
- ~~H.20~~ **Direct** IMD to restore the following:
- (a.) **Remove** the digital pressure instrument downstream of 1/2-2941-8A:
    - (1) **Verify closed** 1/2-2941-8A. JM1
    - (2) **Remove** the digital pressure instrument downstream of 1/2-2941-8A **AND cap** 1/2-2941-8A. JM1
- Installed by: JM1 Date: current
- Verified by: JM2 Date: current

~~H.20~~ (cont'd)

~~b.~~ **IF** an IST Group B Pump Test using temporary digital inlet pressure gauge was performed, **THEN remove** the digital pressure instrument downstream of 1/2-2941-1A:

(1) **Verify closed** 1/2-2941-1A. IM1

(2) **Remove** the temporary digital pressure instrument **AND cap** 1/2-2941-1A.:

Installed by: IM1 Date: current

Verified by: IM2 Date: current

~~H.21.~~ **Position** 1/2-2999-9, as follows:

(a) **IF** Freon head pressure is < 260 psig as indicated on PI 1/2-5711-1 **AND** PI 1/2-5741-2, **THEN open** 1/2-2999-9. EO/MSO

(b) **IF** Freon head pressure is  $\geq$  260 psig as indicated on PI 1/2-5711-1 **OR** PI 1/2-5741-2, **THEN close** 1/2-2999-9. N/A/MSO

H.22. **Verify** SSMP is in standby lineup:

a. At Control Room Panel 912-8:

Component	Position	Initial
MO 1/2-2901-6	Open $\geq 7\%$ digital <b>OR</b> 3/16 in. on valve	_____
MO 1/2-2901-7	Closed	_____
FIC 1/2-2940-7 AUTO/MANUAL setting	MANUAL ( $\approx$ lit)	_____
FIC 1/2-2940-7 Flow setpoint as indicated by value at bottom of scale	200 gpm	_____

b. In SSMP Room:

Component	Position	Initial
<b>IF</b> an IST Group B Pump Test using temporary digital inlet pressure gauge was performed, <b>THEN</b> 1/2-2941-1A	Closed	_____
1/2-2941-8A	Closed	_____
1/2-2999-9	<b>IF</b> Freon Pressure $< 260$ psig, <b>THEN</b> Open	_____
	<b>IF</b> Freon Pressure $\geq 260$ psig, <b>THEN</b> Closed	

H.23. **IF** this surveillance was satisfactory, **THEN**:

- a. Satisfactory with discrepancies  
**AND** corrective actions  
performed, as noted: \_\_\_\_\_ Yes \_\_\_\_\_ N/A

Comments: \_\_\_\_\_  
\_\_\_\_\_

b. **IF** pump is in the IST Alert Range, **THEN**  
**evaluate** and **disposition** per ER-AA-321. \_\_\_\_\_

c. Surveillance completed by: \_\_\_\_\_ / \_\_\_\_\_  
Signature Date

d. Surveillance approved by: \_\_\_\_\_ / \_\_\_\_\_  
US Signature Date

H.24. **IF** this surveillance was unsatisfactory, **THEN**:

a. **OPERATOR**

(1) **Describe** Deficiencies/Comments:

\_\_\_\_\_  
\_\_\_\_\_

(2) Surveillance completed by:

\_\_\_\_\_ / \_\_\_\_\_  
Signature Date

b. **UNIT SUPERVISOR**

(1) **Evaluate** and **disposition** pump  
discrepancies per ER-AA-321. \_\_\_\_\_

(2) **IF** a component fails to meet IST  
Pass/Fail criteria, **THEN** component  
is INOPERABLE: \_\_\_\_\_

(a) **Initiate** an Issue Report. \_\_\_\_\_

(b) **Initiate** QCAP 0230-19. \_\_\_\_\_

(3) Comments: \_\_\_\_\_  
\_\_\_\_\_

H.24.b (cont'd)

(4) Surveillance completed by:

\_\_\_\_\_  
US Signature

\_\_\_\_\_  
Date

## **I. ATTACHMENTS**

I.1. Attachment A: Figure 1, Safe Shutdown Makeup Pump Vibration Points.

## **J. REFERENCES**

### **J.1. Technical Specifications:**

a. TS 3.7.9, Safe Shutdown Makeup Pump (SSMP) System.

### **J.2. P&IDs:**

a. M-70, Diagram of Safe Shutdown Make-up System.

### **J.3. Drawings:**

a. 4E-6613A, Schematic Diagram Safe Shutdown System MOs 1/2-2901-6 & 1/2-2901-7.

b. 4E-6613B, Schematic Diagram Safe Shutdown System MOs 1-2901-8 & 2-2901-8.

c. 4E-6623, Key Diagram 4160V Swgr Bus 31 Safe Shutdown System.

d. 4E-6624, Schematic Diagram 4160V Bus 24-1 Safe Shutdown Sys Alt Feed & 4160V Bus 31 Safe Shutdown Sys Transf Feed Control.

### **J.4. Manuals:**

a. VETI #C00024B, Safe Shutdown Pump.

b. Technical Requirements Manual (TRM) Section 5.5.6, Inservice Testing Program.

**J.5. Procedures:**

- a. ER-AA-321, Administrative Requirements for Inservice Testing.
- b. OP-AA-103-105, Limitorque Motor-Operated Valve Operations.
- c. OP-QC-201-012-1001, Quad Cities On-Line Fire Risk Management.
- d. QCAP 0230-19, Equipment Operability.
- e. QCOP 2900-01, Safe Shutdown Makeup Pump System Preparation for Standby Operation.
- f. QCOP 2900-04, Safe Shutdown Makeup Pump System Shutdown.
- g. QCOS 2900-03, Safe Shutdown Makeup System Power Operated Valve Test.
- h. QCOS 2900-08, Safe Shutdown Makeup Pump Comprehensive/Performance Test.

**J.6. UFSAR:**

- a. Section 3.9.6, Inservice Testing of Pumps and Valves.
- b. Section 5.4.6.5, Safe Shutdown Makeup System.
- c. Section 9.5.1, Fire Protection System None.

**J.7. Commitments:**

None.

J.8. **Others:**

- a. Emergency Procedure Guidelines, Appendix B.
- b. Fire Protection Reports, Volume 2.
- c. Letter B. Rybak to R. Bax dated 8-29-86, subject: "Operability of Safe Shutdown Equipment (Appendix R)."
- d. SESR# 4-2963, Motor Start Limitations for MOV 1/2-2901-6.
- e. QDC-2900-M-0472, Rev. 001 Determination of Pressure Required for SSMP Injection Under Safe Shutdown Conditions.
- f. AT 370284-04, Review of 1(2)-2901-10 Valve Performance: Review and Document Back Leakage as Being Acceptable.
- g. QDC-2900-M-0721 Rev. No. 000, Editorial Changes to Page #5 of the Calculation (NPSH Analysis for Safe Shutdown Make-up Pump).
- h. EC 333177, Rev. 0, Evaluate the Use of the Druck DPI610 Pressure Calibrator.
- i. QCPWG (Procedure Writer's Guide) Vol 3.

**ATTACHMENT A (Page 1 of 1)**

**FIGURE 1  
SAFE SHUTDOWN MAKEUP PUMP VIBRATION POINTS**

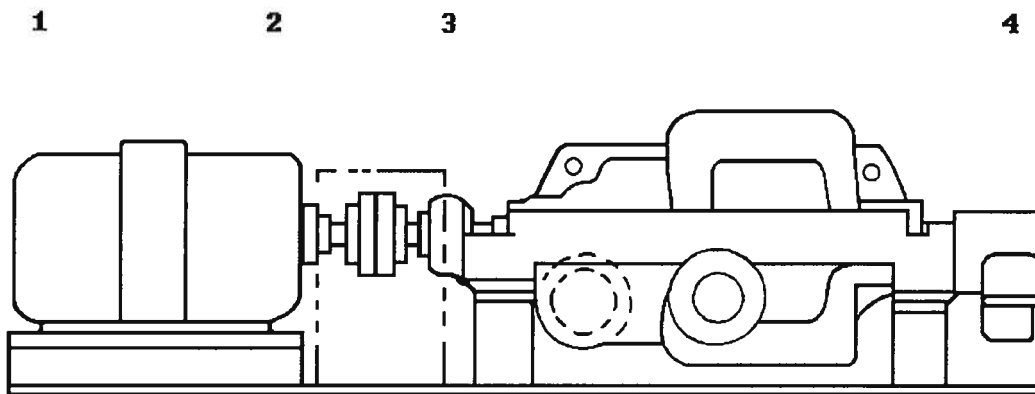

# IST Pump Test Acceptance Criteria Sheet

Procedure QCOS 2900-01 (U0)

Page 1 of 1

Pump EPN	Test Designator	Reference Value	Acceptable Range	Alert Range	Required Action Range
0-2901	DP	1286.99	1222 to 1415	N/A	Hi: > 1415.
				N/A	Low: <1222.

Prepared by: *[Signature]* 2/22/10  
IST Program Engineer Date

Reviewed by: *[Signature]* 3/10/10  
Engineering Programs Manager Date

**Job Performance Measure****Take a Control Rod Out-of-Service on the RWM**JPM Number: RO A2Revision Number: 00Date: 02/01/2024Developed By: \_\_\_\_\_  
Instructor: Print / Sign \_\_\_\_\_ Date \_\_\_\_\_Reviewed By: \_\_\_\_\_  
SME or Instructor: Print / Sign \_\_\_\_\_ Date \_\_\_\_\_Reviewed By: \_\_\_\_\_  
Operations Representative: Print / Sign \_\_\_\_\_ Date \_\_\_\_\_Approved By: \_\_\_\_\_  
Training Department: Print / Sign \_\_\_\_\_ Date \_\_\_\_\_

## JOB PERFORMANCE MEASURE VALIDATION CHECKLIST

**NOTE:** All steps of this checklist should be performed upon initial validation.  
Prior to JPM usage, revalidate JPM using steps 9 and 13 below.

1. Task description and number, JPM description and number are identified. \_\_\_\_\_
2. Knowledge and Abilities (K/A) references are included. \_\_\_\_\_
3. Performance location specified. (in-plant, control room, simulator, or other) \_\_\_\_\_
4. Initial setup conditions are identified. \_\_\_\_\_
5. Initiating cue (and terminating cue if required) are properly identified. \_\_\_\_\_
6. Task standards identified and verified by instructor or SME review. \_\_\_\_\_
7. Critical steps meet the criteria for critical steps and are identified with an asterisk (\*). \_\_\_\_\_
8. IAW NUREG 1021 Appendix C, clearly identify the task standard (i.e., the predetermined qualitative or quantitative outcome) against which task performance will be measured. \_\_\_\_\_
9. Verify the procedure(s) referenced by this JPM reflects the current revision:
 

Procedure: <u>QCOP 0207-01, ROD WORTH MINIMIZER OPERATION</u>	Revision: <u>32</u>
Procedure: _____	Revision: _____
Procedure: _____	Revision: _____
10. Verify cues both verbal and visual are free of conflict. \_\_\_\_\_
11. Verify performance time is accurate. \_\_\_\_\_
12. If the JPM cannot be performed as written with proper responses, then revise the JPM. \_\_\_\_\_
13. When JPM is initially validated, sign and date JPM cover page. For subsequent validations, sign and date below: \_\_\_\_\_

\_\_\_\_\_/\_\_\_\_\_  
SME / Instructor (Print/Sign) \_\_\_\_\_  
Date

\_\_\_\_\_/\_\_\_\_\_  
SME / Instructor (Print/Sign) \_\_\_\_\_  
Date

\_\_\_\_\_/\_\_\_\_\_  
SME / Instructor (Print/Sign) \_\_\_\_\_  
Date

**Revision Record (Summary)**

<b>Revision #</b>	<b>Summary</b>
00	New JPM developed for the 2024 ILT NRC Exam IAW NUREG 1021 Rev. 12, Section ES-3.2, D.

### SIMULATOR SETUP INSTRUCTIONS

1. Reset the simulator to IC-19 (50% power).

**NOTE:** It is okay to use a similar IC to the IC listed above, provided the IC actually used is verified to be compatible with this and other JPMs that are scheduled to be run concurrently.

2. Manual Actions:

- Depending on the simulator IC, if necessary, insert control rod F-8 to position 00.
- Verify the RWM MODE SELECT switch is in NORMAL.
- Verify the RWM Primary Display screen is selected.

Remote Functions:

- **RD06R2231R INOP** (Remove HCU 22-31 from service)

3. Prepare a copy of QCOP 0207-01 with the prerequisites and step F.5.a signed off by the Unit Supervisor.
4. This completes the setup for this JPM.

### INITIAL CONDITIONS

- You are the U-1 NSO.
- Control rod F-8 drifted in to position 00 late last shift.
- The control rod has been declared inoperable and electrically disarmed.
- The CRDA analysis has been verified per NF-QC-721, CONTROL ROD SEQUENCES AND FORMS.
- The U-1 Supervisor has directed you to remove control rod F-8 from service on the RWM.
- This JPM is NOT time critical.

### INITIATING CUE

Remove control rod F-8 from service on the RWM per QCOP 0207-01, step F.5.

**Provide examinee with:** Marked up copy of QCOP 0207-01, ROD WORTH MINIMIZER OPERATION.

Fill in the JPM Start Time when the student acknowledges the Initiating Cue.  
.....

#### Information For Evaluator's Use:

UNSAT requires written comments on respective step.

\* Denotes critical steps.

Number any comments in the "Comment Number" column on the following pages. Then annotate that comment in the "Comments" section. The comment section should be used to document: the reason that a step is marked as unsatisfactory, marginal performance relating to management expectations, or problems the examinee had while performing the JPM.

Comments relating to procedural, or equipment issues should be entered and tracked using the site's appropriate tracking system.

Some operations that are performed from outside of the control room may require multiple steps. These items may be listed as individual steps in this JPM. It is acceptable for the candidate to direct the local operator to perform groups of procedure steps instead of calling for each individual item to be performed.

The timeclock starts when the candidate acknowledges the initiating cue.  
.....

JPM Start Time: \_\_\_\_\_ JPM Sequence #: \_\_\_\_\_ of \_\_\_\_\_

<b><u>Task Standard:</u></b>					
Remove a control rod from service on the RWM by performing the following actions: select the SECONDARY FUNCTIONS box, select the desired control rod on the Rod Select Matrix and the RWM, then select the ROD OUT OF SERVICE function, and the RETURN TO PRIMARY box using QCOP 0207-01.					
<b><u>STEP</u></b>	<b><u>ELEMENT</u></b>	<b><u>STANDARD</u></b>	<b>SAT</b>	<b>UNSAT</b>	<b>Comment Number</b>
*F.5.b.	Select Secondary Functions.	On the RWM Screen: Selects "SECONDARY FUNCTIONS" box.	<input type="checkbox"/>	<input type="checkbox"/>	—
*F.5.c.	Select the control rod on the Rod Select Matrix.	At the 901-5 panel: – *Selects control rod F-8 on the Rod Select Matrix.* – Verifies pushbutton for F-8 latches and backlights.	<input type="checkbox"/>	<input type="checkbox"/>	—
*F.5.d. & F.5.e.	Select the control rod on the RWM Screen.	On the RWM Screen: – *Selects control rod F-8 on the RWM Full Core Display.* – Verifies control rod F-8 is enclosed in a blue box.	<input type="checkbox"/>	<input type="checkbox"/>	—
*F.5.f.	Select ROD OUT OF SERVICE function.	On the RWM Screen: – *Selects the "ROD OUT OF SERVICE" box.* – Verifies "Rod F-8 placed out of service" message is displayed in the Scratch Area. – Verifies rod status below the bounds appears as "OOSERV".	<input type="checkbox"/>	<input type="checkbox"/>	—

<u>STEP</u>	<u>ELEMENT</u>	<u>STANDARD</u>	SAT	UNSAT	Comment Number
F.5.g.(1)	Verify RWM blocks are applied.	On the RWM Screen: <ul style="list-style-type: none"> <li>– Verifies Insert and Withdraw blocks are applied as indicated by magenta and red bars above and below the rod bounds.</li> </ul>	<input type="checkbox"/>	<input type="checkbox"/>	—
<b>EVALUATOR NOTE: Insert and Withdraw blocks are applied because the rod is at position 00. If the control rod was not full in, then only a Withdraw block is applied.</b>					
*F.5.g.	Return to Primary Menu screen.	On the RWM Screen: <ul style="list-style-type: none"> <li>– *Selects “RETURN TO PRIMARY” box.*</li> <li>– Verifies Primary Menu screen is displayed.</li> </ul>	<input type="checkbox"/>	<input type="checkbox"/>	—
F.5.h.	Verify the control rod is at the required OOS position.	Verifies control rod F-8 is at position 00 on the Full Core Display and the RWM Full Core Display.	<input type="checkbox"/>	<input type="checkbox"/>	—
F.5.i.(1) thru (3)	Deselect and Reselect control rod and verify RWM blocks are applied.	On the rod Select Matrix: <ul style="list-style-type: none"> <li>– Deselects rod F-8 by selecting another rod or by cycling the Rod Select Matrix power switch.</li> <li>– Reselects control rod F-8.</li> </ul> On the Primary Menu Screen: <ul style="list-style-type: none"> <li>– Verifies control rod F-8 is indicated in light blue.</li> <li>– Verifies Insert and Withdraw blocks are applied on the rod bounds.</li> </ul>	<input type="checkbox"/>	<input type="checkbox"/>	—

<u>STEP</u>	<u>ELEMENT</u>	<u>STANDARD</u>	SAT	UNSAT	Comment Number
<b>EVALUATOR NOTE: Deselecting and reselecting the control rod will apply Insert and Withdraw block regardless of the control rod position. Now the control rod cannot be moved until it is returned to service on the RWM.</b>					
<b>EVALUATOR NOTE: The examinee should inform you that the task is complete.</b>					

JPM Stop Time: \_\_\_\_\_

.....

**JPM SUMMARY****Operator's Name:** \_\_\_\_\_ **Emp. ID#:** \_\_\_\_\_**Job Title:**  EO  RO  SRO  FS  STA/IA  SRO Cert

JPM Title: Take a Control Rod Out-of-Service on the RWM

JPM Number: RO A2

Revision Number: 00Task Number and Title: **SR-0207-P02** (Freq: LIC=I) Given an operating reactor, perform the following RWM operations in accordance with QCOP 0207-01 and QCOP 0207-02.**0207.009** Take a rod OOS and return a rod to service on the RWM (901(2)-5)**Task Standard:** Remove a control rod from service on the RWM by performing the following actions: select the SECONDARY FUNCTIONS box, select the desired control rod on the Rod Select Matrix and the RWM, then select the ROD OUT OF SERVICE function, and the RETURN TO PRIMARY box using QCOP 0207-01.K/A Number and Importance: **K/A:** 2.2.14**Rating:** RO/SRO 3.9/4.3

Suggested Testing Environment: Simulator

Alternate Path:  Yes  No SRO Only:  Yes  No Time Critical:  Yes  No

Reference(s):

Procedure: QCOP 0207-01, ROD WORTH MINIMIZER OPERATION Revision: 32

Procedure: \_\_\_\_\_ Revision: \_\_\_\_\_

Procedure: \_\_\_\_\_ Revision: \_\_\_\_\_

**Actual Testing Environment:**  Simulator  Control Room  In-Plant  Other**Testing Method:**  Simulate  Perform**Estimated Time to Complete:** 5 minutes**Actual Time Used:** \_\_\_\_\_ minutes**EVALUATION SUMMARY:**Were all the Critical Elements performed satisfactorily?  Yes  NoThe operator's performance was evaluated against standards contained within this JPM and has been determined to be:  Satisfactory  Unsatisfactory**NOTE:** Enter finalized grading, comments, and notes relevant to this evaluation in the associated TQ-AA-150-F03A/B. (See AR [4282419](#)).**Evaluator's Name (Print):** \_\_\_\_\_**Evaluator's Signature:** \_\_\_\_\_ **Date:** \_\_\_\_\_

**Page Intentionally Left Blank**

### **INITIAL CONDITIONS**

- You are the U-1 NSO.
- Control rod F-8 drifted in to position 00 late last shift.
- The control rod has been declared inoperable and electrically disarmed.
- The CRDA analysis has been verified per NF-QC-721, CONTROL ROD SEQUENCES AND FORMS.
- The U-1 Supervisor has directed you to remove control rod F-8 from service on the RWM.
- This JPM is NOT time critical.

### **INITIATING CUE**

Remove control rod F-8 from service on the RWM per QCOP 0207-01, step F.5.

## ROD WORTH MINIMIZER OPERATION

### ~~A.~~ PURPOSE

The purpose of this procedure is to provide the necessary steps to initialize the Rod Worth Minimizer (RWM) Program, acknowledge RWM Alarms, take Rods out of service, perform Single Rod Testing, and perform Diagnostic Testing.

### ~~B.~~ DISCUSSION

~~B.1.~~ Design Basis of RWM is to serve as a backup to procedural control to limit Control Rod Worth during Startup and Low Power Operation.

~~B.2.~~ The RWM is **NOT** designed to prevent Control Rod withdrawal past the Target Position as specified in the sequence.

~~B.3.~~ The Logic Circuitry stops the notch override function but allows the 1.5 second notch out function on the timer to complete.

~~B.4.~~ Latching to a step in the sequence consists of comparing the current Control Rod pattern to each step in the loaded sequence. At each step, a count of Control Rods not within limits for that step is made. The step with the least number of Rods outside of limits is termed the latched step. **IF** more than one step has this calculated lowest count, **THEN** RWM will latch to any one of these steps containing the selected Rod. For this reason, the RWM may not latch to the next expected step following CRAM insertion. **IF** this happens, **THEN** RWM will only allow the correction of the withdraw errors via Rod insertion. Rod insertion should continue, if required, with the next in-sequence step to its target position.

~~B.5.~~ **IF** a Control Rod is taken Out of Service (OOS) at a position other than "00", **AND** shows an 'OOS Rod Not Fully Inserted' alarm, **THEN** the alarm will **NOT** automatically clear when the OOS rod is taken to "00". A relaunch of the application **OR** navigating away and back to the application may be necessary to clear the alarm message. (H.8.d)

~~B.6.~~ Attachment A is a list of RWM Messages that may appear on the screen during RWM operation.

~~C.~~ **PREREQUISITES**

- ~~C.1.~~ RPIS is operable. MS
- ~~C.2.~~ RWM Control Rod Sequence has been loaded as necessary. MS
- ~~C.3.~~ RWM MODE SELECT switch in NORMAL position unless bypassed per QCOP 0207-02. MS

~~D.~~ **PRECAUTIONS**

- ~~D.1.~~ In the upper left of the RWM Primary Display, the server listed should also be the server at active status (for example: PPC-U1(2)A with status A:ACT B:STBY or PPC-U1(2)B with status A:STBY B:ACT). Also both blocks should **NOT** be purple.

~~E.~~ **LIMITATIONS AND ACTIONS**

- ~~E.1.~~ Conditions for which Insert and Withdraw Blocks are applied by the RWM System:
- ~~a.~~ Any Rod withdrawn one **OR** more notches beyond its withdraw limit will cause a **Withdraw** Block to be issued for all Rods. **Insert** Blocks will be issued for all Rods except for Rods which have withdraw errors. Rods with withdraw errors may be inserted to the correct position.
- ~~b.~~ Any Rod inserted one **OR** more notches beyond its insert limit will cause an **Insert** Block to be issued for all Rods except Rods with withdraw errors or Rods in the current sequence step. **Withdraw** Blocks will be issued for all Rods except Rods with insert errors.
- ~~c.~~ Any out-of-sequence Rod selected will cause an insert and withdrawn block to be applied for the selected Rod with one exception: Insertion/withdrawal of an out of sequence Rod is allowed in order to correct a withdraw/insert error.
- ~~d.~~ Whenever the RWM is initialized or Reactor Power is below the Low Power Setpoint (below 15% of Rated Steam Flow or below 17% of Rated Feedwater Flow), all Insert and Withdraw blocks are active. The Low Power Setpoint corresponds to approximately 20% Core Thermal Power.

~~E.1.~~ (cont'd)

~~e.~~ Whenever RWM is operational, select block function should be enabled. Select block function may be disabled at the discretion of the Unit Supervisor, Qualified Nuclear Engineer or as allowed by approved Station Procedures.

~~f.~~ Whenever Reactor Power is above the Low Power Setpoint, FULL POWER blocks should be enabled. FULL POWER blocks may be disabled above the Low Power Setpoint at the discretion of the Unit Supervisor, Qualified Nuclear Engineer or as allowed by approved Station Procedures.

~~g.~~ **IF** the RWM fails **OR** is powered down with the MODE SELECT switch in NORMAL (NORM), **THEN** insert and withdraw blocks will be applied at any power upon restoration.

~~E.2.~~ A maximum of one Control Rod **NOT** fully inserted per BPWS group may be placed OOS **IF** Shutdown Margin (SDM) is met. (H.8.b)

~~E.3.~~ The Rod Worth Minimizer (RWM) shall be OPERABLE in OPERATIONAL MODES 1 AND 2 when thermal power is less than or equal to 10% of Rated Thermal Power. (H.1.b)

~~E.4.~~ In Modes 1 and 2 with Thermal Power  $\leq$  10% RTP, the bypassing (taking out of service) and position of Control Rods required to be bypassed in the RWM shall be verified by a second licensed Operator or other qualified member of the technical staff per Tech Spec SR 3.3.2.1.9. This is required prior to and during the movement of Control Rods bypassed in the RWM. Initialing the appropriate rod location line on the Control Rod move sheet and/or initiating a Unit Log entry may be used to document verification. (H.1.b)

~~E.5.~~ **IF** desired to initiate a manual Control Rod scan, **THEN** a scan request can be initiated from either the RWM Main Menu by selecting REQUEST SCAN or from the PPC Rod Monitoring Screen by selecting PERFORM SCAN.

**F. PROCEDURE**

F.1. **IF** required, **THEN load** a new RWM sequence [NSO, QRE, QNE, or US]:

a. **Obtain** Unit Supervisor permission to Load Sequence. \_\_\_\_\_

b. **Select** SECONDARY FUNCTIONS button from the RWM Primary Display. \_\_\_\_\_

F.1. (cont'd)

- c. **Select** SEQUENCE LOAD button from the RWM Secondary Functions Display. \_\_\_\_\_
- d. Either **touch** the "Select the sequence file name" area of the Sequence Load/Transfer screen **OR select** the SELECT SEQUENCE button to bring up a pick list. \_\_\_\_\_
- e. **Select** the file name desired, then **click** "OK". \_\_\_\_\_
- f. **Verify** Sequence Name **AND** Sequence Key Word that appear in the center left of the display are the correct sequence and key word. \_\_\_\_\_
- g. **Select** the LOAD SEQUENCE button on the Sequence Load/Transfer screen. \_\_\_\_\_
- h. **Select** CONTINUE to load the sequence **OR** CANCEL to **NOT** load the sequence. \_\_\_\_\_
- i. **Verify** message area of the Sequence Load/Transfer screen indicates sequence has been loaded. \_\_\_\_\_
- j. **Return** to the RWM Primary display by either using the "previous display" icon, **OR** by selecting the "RWM" icon, and **verify** the new sequence name and key word now appear in the display. \_\_\_\_\_
- k. **Enter** any Rods required to be OOS or to have substitute Rod positions or Alternate Limits. \_\_\_\_\_
- l. **Update** CRAM tape on the rod select matrix. \_\_\_\_\_
- m. **Direct** QNE or QRE (Qualified Reactor Engineer) to **verify** Rod sequence is in conformance with the Analyzed Rod Sequence **AND** to document verification on the sequence cover page. (H.1.b). \_\_\_\_\_

**NOTE**

The most recent alarm message will be displayed at the bottom area of the screen.

A list of RWM Messages is provided on Attachment A.

The RWM Message Summary may be accessed under the Review Functions Menu.

RWM alarm messages are accessed in the same manner as all Plant Process Computer alarms, through the Alarms Menu.

- F.2. **IF** alarm and error messages are to be reviewed/acknowledged/cleared, **THEN** **review/acknowledge/clear** alarms and error messages per QCOP 9950-02.
- F.3. **IF** using the RWM to monitor Control Rod positions during Rod movements, **THEN**:
- a. **Use** the upper left portion of the Main Display Screen for the following information:
- (1) The first line contains the selected Rod.
  - (2) The second line contains the position of the selected Rod.
  - (3) The third line contains the correct position for the selected Rod according to the current latched step of the RWM. If the selected Rod is in the current latched step, a range of allowable positions will be displayed.
- b. **Use** the lower left area of the Main Display Screen for the following information about the current latched step in the sequence:
- (1) The first line contains the current latched step in the sequence.
  - (2) The second line contains the array designation that is to be moved in this step.
  - (3) The third line contains the range of movement allowed for the Rods in this step.

F.3. (cont'd)

- c. **Use** the center portion of the Main Display Screen for the full core display showing all current Rod positions.
- (1) Rods that appear green are in the current latched step.
  - (2) Rods that appear red are Rods that have withdraw errors.
  - (3) Rods that appear magenta are Rods that have insert errors.
  - (4) Rods that appear light blue are Rods that have been taken out of service with the RWM.
  - (5) Rods that appear yellow are Rods that have had a substitute value entered for their position.
  - (6) All other Rods will appear white on the Full Core Display.
  - (7) The selected Rod will be displayed in inverse video to highlight it.

- F.4. **IF** a substitute Control Rod position is to be entered for a Rod with bad position indication from RPIS, **THEN** **refer** to QCOP 9950-07.

~~E.5.~~

**IF** a Control Rod is to be taken out of service with the RWM, **THEN**:

**NOTE**

The RWM OOS function enforces the following BPWS and Technical Specifications constraints:

- A maximum of 8 Rods may be OOS at any one time. (H.1.a)
- A maximum of 3 Rods per BPWS Group may be OOS at any one time.
- OOS Rods in the same Banked Position Withdrawal Sequence (BPWS) group must be separated from each other by at least two Rod cells.
- A maximum of one Rod **NOT** fully inserted per BPWS group may be placed OOS. (E.2.)

a.

**Contact** QNE to revise control rod sequence and **verify** assumptions of CRDA analysis will be met per NF-QC-721.

MS

- b. **Select** SECONDARY FUNCTIONS. \_\_\_\_\_
- c. **Select** the Rod to be taken OOS on the select matrix. \_\_\_\_\_
- d. **Select** the Rod to be taken OOS on the RWM Screen. \_\_\_\_\_
- e. **Verify** the Rod is enclosed in a blue box. \_\_\_\_\_
- f. **Select** ROD OUT OF SERVICE and **verify** message "Rod **XXX** placed out of service". \_\_\_\_\_

**NOTE**

**Maintain** Rod to be taken OOS "selected" on the select matrix until placed at target position. **IF** the Rod was left at a position other than 00, **THEN** it can **NOT** be inserted to 00 if it is deselected on the matrix.

F.5. (cont'd)

- g. **Verify** one of the following: \_\_\_\_\_
  - (1) **IF** the Rod is at 00, **THEN** insert and withdraw blocks are applied. \_\_\_\_\_
  - (2) **IF** the Rod is **NOT** at 00, **THEN** a withdraw block is applied, but **NO** insert block is applied. \_\_\_\_\_
- g. **Select** RETURN TO PRIMARY to return to the Primary Menu. \_\_\_\_\_
- h. **Verify** Control Rod is at the required OOS position. **IF** the Rod is to be left at 00, **THEN insert** Rod to 00. \_\_\_\_\_
- i. **WHEN** Rod is at target position, **THEN:**
  - (1) **Deselect** Rod. \_\_\_\_\_
  - (2) **Reselect** Rod. \_\_\_\_\_
  - (3) **Verify** the Rod is indicated in light blue **AND** has both insert and withdraw blocks applied. \_\_\_\_\_

F.6. **IF** a Control Rod is to be returned to service, **THEN:**

**NOTE**

The Unit Supervisor should be contacted to determine any testing requirements for any Rods returned to service.

- a. **Select** SECONDARY FUNCTIONS. \_\_\_\_\_
- b. **Select** Rod to be returned. \_\_\_\_\_
- c. **Select** ROD OUT OF SERVICE. \_\_\_\_\_
- d. **Verify** message "Rod XXX placed in service". \_\_\_\_\_
- e. **Select** RETURN TO PRIMARY and **verify** Rod indicates normal mode when selected. \_\_\_\_\_

F.6. (cont'd)

- f. **Contact** a QNE to determine any maneuvers required to restore the Rod to the Rod Sequence. \_\_\_\_\_

- F.7. **IF** an alternate limit for a Control Rod is to be enabled, **THEN**:

**NOTE**

The following alternate limits are valid:

- Position 02 for 00. (unlimited number of Rods)
- Position 46 for 48. (unlimited number of Rods)
- One notch **in** from the present target limit for any Rod. (maximum of two Rods)

To enable an alternate limit for a Rod, it must already be at the correct alternate position **OR** at the target in or target out limit for that Rod.

Once an alternate limit is enabled, movement of the Rod will disable the alternate limit, unless movement of the Rod is from the target in or target out limit to the alternate limit.

- a. **Contact** QNE to **verify** assumptions of CRDA analysis will be met per NF-QC-721. \_\_\_\_\_
- b. **Verify** Control Rod position is at the desired alternate position, then **select** SECONDARY FUNCTIONS. \_\_\_\_\_
- c. **Select** Rod to have alternate position enabled, then **verify** selection is enclosed in a blue box. \_\_\_\_\_
- d. **Select** ALTERNATE LIMITS. \_\_\_\_\_
- e. **Verify** message "Rod XXX alternate limit enabled". \_\_\_\_\_
- f. **Select** RETURN TO PRIMARY to return to the Primary Menu. \_\_\_\_\_

F.7. (cont'd)

- g. **IF** a Rod with alternate limits is selected, **THEN verify** ALTERN is displayed in the Rod information area of the Main Display Screen. \_\_\_\_\_
- h. **Request** ONE to revise control rod sequence to reflect use of alternate limit. \_\_\_\_\_

F.8. **IF** Control Rods are to be moved for testing **OR** maintenance with all Rods in **AND** ROD TEST is to be used, **THEN**:

- a. **Select** SPECIAL MODES. \_\_\_\_\_
- b. **Select** ROD TEST. \_\_\_\_\_
- c. **Verify** RWM is now in Rod Test Mode. \_\_\_\_\_

**NOTE**

Any one Rod in the core may be moved as long as all other Rods are at position 00.

- d. To exit Rod Test Mode, **select** RETURN TO Normal Mode to return to Primary Menu. \_\_\_\_\_

**CAUTION**

Rod Exercise mode should **NOT** be used below 10 percent of Rated Core Thermal Power due to Banked Position Withdrawal Sequence (BPWS) constraints.

F.9. **IF** Control Rods are to be moved one notch for testing/exercising and ROD EXERCISE is to be used, **THEN**:

- a. **Select** SPECIAL MODES. \_\_\_\_\_
- b. **Select** ROD EXERCISE. \_\_\_\_\_

F.9. (cont'd)

- c. **Verify** RWM displays the ROD EXERCISE screen and shows all of the Control Rods at their initial positions and all in white except for the selected Rod, Rods with substitute positions, and OOS Rods. \_\_\_\_\_

**NOTE**

Any one Control Rod may be inserted a single notch. **IF** Rod is at position 00, **THEN** it may be moved to 02.

The Control Rod must be returned to its initial position before another Control Rod is allowed to be moved.

- d. **Verify** the selected Control Rod is displayed in green indicating that movement is allowed. \_\_\_\_\_
  - e. **WHEN** exercising is complete, **THEN** select RETURN TO NORMAL MODE to return to the primary menu. \_\_\_\_\_
- F.10. **IF** Control Rods are to be SCRAM timed **AND** the SCRAM TIMING function is to be used, **THEN**:
- a. **Select** SPECIAL MODES from the Primary Menu. \_\_\_\_\_
  - b. **Select** SCRAM TIMING. \_\_\_\_\_
  - c. **Verify** the RWM displays the SCRAM TIMING screen and shows all of the Control Rods except the selected Rod, at their initial positions in white. \_\_\_\_\_
  - d. **Bypass** RWM as applicable per QCOP 0207-02. \_\_\_\_\_

F.10. (cont'd)

**NOTE**

Even if the RWM is bypassed, it will still perform auto Rod scans unless the RWM is in SCRAM TIMING mode.

In scram timing mode, automatic Rod scans are disabled to prevent interference with data transfer to PPC.

To request a new scan to update the Control Rod positions while in SCRAM TIMING mode, MANUAL SCAN must be selected. This will update the computer so that the current positions are the initial positions.

- e. **Verify** the selected Control Rod is displayed in green indicating that movement is allowed. \_\_\_\_\_
- f. **WHEN** scram timing is complete, **THEN** select NORMAL MODE to return to the Primary Menu, and **reload** new sequence as necessary per step F.1. \_\_\_\_\_

F.11. **IF** rapid insertion of CRAM Rods to the full in position and POWER REDUCTION is to be used, **THEN:**

- a. **Select** POWER REDUCTION from any menu. \_\_\_\_\_
- b. **Depress** ARRAY MODE to latch all CRAM arrays. \_\_\_\_\_
  - (1) Once the first CRAM Rod is selected, all Rods specified in the sequence as CRAM Rods will be green, all other Rods will be white.
  - (2) The RWM will latch the groups containing the CRAM Rods.

**NOTE**

The RWM will allow the CRAM Rods to be inserted to the full in position. Once all CRAM Rods are fully inserted, further in sequence Rod insertion can be performed when POWER REDUCTION mode is exited. The selected CRAM Rod will change color while selected and driving.

F.11. (cont'd)

- c. **Continuously insert** CRAM Rods (shown in green) in sequence to position 00 until Reactor power has stopped increasing **AND** operation is outside ICA region II as indicated in QCOA 0400-02. \_\_\_\_\_
- d. **Select** RETURN TO NORMAL MODE to exit POWER REDUCTION mode. \_\_\_\_\_

**NOTE**

**WHEN** the Scram Function is ENABLED **AND** a RPS scram signal is detected, **THEN** the RWM will automatically enter SCRAM MODE at an accelerated scan rate. ALL IN will be displayed when all Rods are at 00. ROD OUT will be displayed if any Rod position is unknown or not at 00.

F.12. **IF** RWM Special Scram Mode is to be used following a Reactor Scram, **THEN**:

- a. **Select** SPECIAL MODES. \_\_\_\_\_
- b. **Select** SCRAM DISPLAY. \_\_\_\_\_
- c. **Verify** the RWM is now in SCRAM MODE. \_\_\_\_\_
- d. **Verify** the following:
  - (1) All Rods at a known position other than 00 are displayed in red. \_\_\_\_\_
  - (2) All unknown Rod positions are displayed as yellow '??'. \_\_\_\_\_
  - (3) All Rods at 00 are displayed as green. \_\_\_\_\_
- e. **Select** RETURN TO NORMAL MODE to return to the Primary Menu. \_\_\_\_\_

F.13. **IF** current status of the RWM is to be displayed, **THEN**:

- a. **Select** REVIEW FUNCTIONS. \_\_\_\_\_
- b. **Select** the VIEW SYSTEM STATUS button on the screen. \_\_\_\_\_

F.13. (cont'd)

- c. **Verify** upper left of the RWM Screen shows the current operating status of the computer. **IF** necessary, **THEN refer** to D.1. \_\_\_\_\_
  
- d. **Verify** report shows a count of Rods that:
  - (1) Have withdraw errors. \_\_\_\_\_
  - (2) Have insert errors. \_\_\_\_\_
  - (3) Have bad position indication. \_\_\_\_\_
  - (4) Have substituted position. \_\_\_\_\_
  - (5) Are Out of service. \_\_\_\_\_
  - (6) Have alternate limits enabled. \_\_\_\_\_

**NOTE**

Disabling Full Power Blocks also disables select blocks, regardless of indicated state of Select Blocks.

Below LPSP enables and enforces RWM Rod blocks, regardless of indicated state of FULL Power Blocks, however select blocks may be enabled or disabled.

Enabling Scram Function will allow the RWM to automatically switch to the SRAM MODE screen when a scram signal is received from RPS. It is recommended that this function be left disabled whereas Rods inserted past 00 will be seen as "bad" by the PPC and will indicate ROD OUT.

- F.14. **IF** an additional menu of items is desired, **THEN select** RWM MAIN MENU box and **perform** the desired function:
- a. **Enable** or **disable** RWM Full Power Blocks. \_\_\_\_\_
  - b. **Enable** or **disable** RWM select blocks. \_\_\_\_\_
  - c. **Enable** or **disable** Scram Function. \_\_\_\_\_
  - d. **Enable** or **disable** Auto-Scan. \_\_\_\_\_

**NOTE**

Re-booting the RWM display can improve sluggish or delayed RWM display response. While the RWM display is re-booting, the RWM function of the Process Computer is still available from the NSO PPC Stations. During normal business hours, IT should be contacted to perform RWM display re-boots.

F.15. If desired to re-boot the Unit 1 RWM Display:

- a. At 1-0941-user1-mon station in New Computer Room (WEC Key F-23), access KVM selector by pressing "Ctrl" key on keyboard twice in succession. \_\_\_\_\_
- b. Select the RWM display station, ppcl-rwm, by using UP and DOWN arrows on keyboard to highlight the port that corresponds to ppcl-rwm. (All ports may not be displayed without scrolling UP/DOWN first) \_\_\_\_\_
- c. Press "Enter" key on keyboard to display the RWM Display. \_\_\_\_\_
- d. Press " (Windows/Start Menu) key on keyboard. \_\_\_\_\_
- e. Select "Power" button using mouse. \_\_\_\_\_
- f. Select "Restart" option from drop-down menu using mouse. \_\_\_\_\_
- g. Select "Ok" button using mouse. \_\_\_\_\_
- h. Verify RWM has re-booted and MCR RWM display is returned to normal. \_\_\_\_\_

F.16. If desired to re-boot the Unit 2 RWM Display:

- a. At 2-0941-user2-mon station in New Computer Room (WEC Key F-23), access KVM selector by pressing "Ctrl" key on keyboard twice in succession. \_\_\_\_\_

F.16. (cont'd)

- b. Select the RWM display station, ppc2-rwm, by using UP and DOWN arrows on keyboard to highlight the port that corresponds to ppc2-rwm. (All ports may not be displayed without scrolling UP/DOWN first) \_\_\_\_\_
- c. Press "Enter" key on keyboard to display the RWM Display. \_\_\_\_\_
- d. Press "" (Windows/Start Menu) key on keyboard. \_\_\_\_\_
- e. Select "Shutdown" button using mouse. \_\_\_\_\_
- f. Select "Restart" option from drop-down menu using mouse. \_\_\_\_\_
- g. Select "Ok" button using mouse. \_\_\_\_\_
- h. Verify RWM has re-booted and MCR RWM display is returned to normal. \_\_\_\_\_

**G. ATTACHMENTS**

- G.1. Attachment A: RWM Messages.

**H. REFERENCES**

H.1. **Technical Specifications:**

- a. TS 3.1.3, Control Rod Operability.
- b. TS 3.3.2.1, Control Rod Block Instrumentation.

H.2. **P&IDs:**

None.

H.3. **Drawings:**

None.

H.4. **Manuals:**

- a. R\*Time User's Manual, Scientech Company, Idaho Falls, Idaho.

H.4. (cont'd)

- b. QDC-03-15, Quad Cities Station Units 1 and 2 Software Requirements Specification (SRS) & Software Design Description (SDD) for the Rod Worth Minimizer (RWM).

H.5. **Procedures:**

- a. QCOP 0207-02, Rod Worth Minimizer Bypass Control.
- b. QCOA 0400-02, Core Instabilities.
- c. QCOP 9950-02, Plant Process Computer Miscellaneous Functions.
- d. QCOP 9950-07, Plant Process Computer Control Rod Positions - Substitutions.
- e. QCOP 9950-61, Plant Process Computer Control Rod Scram Timing.

H.6. **UFSAR:**

None.

H.7. **Commitments:**

None.

H.8. **Other:**

- a. Enhanced BPWS Analysis, MOE-42-0386 Jun 1986.
- b. NEDO 21231.
- c. EC 393282, Nuclear Fuel Transition to AREVA Fuel.
- d. IR 2716242, Unexpected OOS Rod Not Fully Inserted RWM Message.
- e. QCPWG (Procedure Writer's Guide) Vol 3.

**ATTACHMENT A (Page 1 of 4)  
 RWM MESSAGES**

RWM Messages shows the alarm messages generated by the Rod timing software. Messages are divided across the System Message Event File (SEF16), the Alarm Summary (ALM), and Direct Error Message presented to the Operator (ERR)

<b>Message Type</b>	<b>Message</b>	<b>Additional Description</b>
ERR	Sequence not loaded. Function disabled.	No Sequence is loaded. Power Reduction Mode is not allowed.
SEF16	Power Reduction Mode Invalid For Loaded Sequence <sequence file name>	No Cram Arrays are defined in Selected Sequence. Power Reduction Mode is not allowed.
ERR	Functions disabled. RWM in Bypass Mode.	Functions are disabled when RWM is in Bypass Mode (Power Reduction, Full Power Toggle, Rod Exercise, Alternate Limits, OOS, Rod Test)
SEF16	Power Reduction Mode Enabled/Disabled	Status of Power Reduction Mode upon change of mode.
SEF16	Less restrictive Power Reduction Mode invalid for loaded sequence <sequence file name>.	Power Reduction /Array Mode - Less Restrictive Power entered.
SEF16	Rod Test Mode Enable/Disabled	Status of Rod Test Mode upon change of mode.
SEF16	Rod Exercise Mode Enable/Disabled.	Status of Rod Exercise Mode upon change of mode.
SEF16	Scram Mode Enable/Disabled	Status of Scram Mode upon change of mode.
SEF16	Scram Timing Mode Enable/Disabled	Status of Scram Timing Mode upon change of mode.
SEF16	Select Blocks Enabled/Disabled	Status of Select Blocks upon change of mode.

**ATTACHMENT A (Page 2 of 4)  
 RWM MESSAGES**

<b>Message Type</b>	<b>Message</b>	<b>Additional Description</b>
SEF16	Full Power Blocks Enabled/Disabled	Status of Full Power Blocks upon change of mode.
SEF16	Scram Function Enabled/Disabled	Status of Scram Function upon change of mode.
ERR	Rod X does not meet sub rod req.	Substitute Rod does not meet requirements.
ERR	Max number of sub rods has been reached.	Substitute Rods exceed maximum number
ERR	Invalid rod/position selected	Substitute Rod position invalid.
RR	Rod X placed in service	Out of Service Rod placed back into Service.
ERR	Rod X placed out of service.	Rod placed Out of Service.
ERR	Rod X can not be placed back into service	Out of Service Rod cannot be placed back into Service.
ERR	OOS Rod Not Fully Inserted	Out of Service Rod which is not fully inserted and the operator has requested return to Primary Mode from Secondary Functions (B.5.)
ERR	Rod X does not meet alt limit req	Selected Rod does not meet Alternate Limits Requirements.
ERR	BPWS violation. OOS Rods must be two cells apart.	Selected Rod for Out of Service does not meet Banked Position Withdrawal Sequence (BPWS) requirements.
ERR	Max OOS rods exceeded (max 8 rods, 3 per BPWS group).	Selected Rod for Out of Service does not meet Banked Position Withdrawal Sequence (BPWS) requirements

**ATTACHMENT A (Page 3 of 4)  
 RWM MESSAGES**

<b>Message Type</b>	<b>Message</b>	<b>Additional Description</b>
ERR	BPWS violation. Max OOS rods not fully inserted.	Selected Rod for Out of Service does not meet Banked Position Withdrawal Sequence (BPWS) requirements
ERR	BPWS violation. OOS not fully inserted two cells apart.	Selected Rod for Out of Service does not meet Banked Position Withdrawal Sequence (BPWS) requirements
SEF16	Scram Count Out = <Counter>	Scram Display Mode; rods not at 0
SEF16	rwm: Latch to New Cram Array X	Cram Array Latch status message
SEF16	rwm: Latch to new step X	Sequence Step Latch status message
SEF16	Rod Movement for X to Y	Status Message for Rod movement.
SEF16	Viewer not running on Workstation X, display not activated.	The dedicated workstation cannot be changed to the Primary Display. The Workstation is not accessible.
ERR	Unable to get environment value for RTIMEHOME	RTIME Home environment variable has not been configured or removed. Server configuration problem.
ERR	Unable to attach to RWM shared memory segment	Create and attach to the RWM shared memory segment has failed. Server configuration problem.
SEF16	RWM: Command line arguments required	Command of RWM Quad1(2) failed. Server configuration problem.
SEF16	RWM: Invalid Database Name entered. Program Aborted	Database Quad1(2) unit designator error. Server configuration problem.

**ATTACHMENT A (Page 4 of 4)  
 RWM MESSAGES**

<b>Message Type</b>	<b>Message</b>	<b>Additional Description</b>
SEF16	RWM: Unable to attach to MMI Config Entry	Attach to the MMI Configuration global common. Server configuration problem.
SEF16	Sequence not loaded, applying rod blocks	Start RWM specific. No Sequence loaded.
SEF16	Error reading failover file Y	Failover file read error. Server configuration problem.
SEF16	Error writing failover file Y	Failover file write error. Server configuration problem.
ERR	X rods are withdrawn. Rod Test Mode invalid.	More than one rod withdrawn prohibits Rod Test mode.
ALM	Rod pos not the same as init pos	Alarm indication after a drift signal was received and there has been no motion detected after a timeout period (3 minute time delay) while not in Scram Timing.
ALM	Phantom rod movement	Alarm indication from rod movement by an unselected rod or a previous rod with no driving operation in process.
ALM	Drift signal received.	Alarm indicated by the receiving of the drift indication and the non-driven movement of the selected rod.
ALM	No rod motion in scram timing	Alarm indication after a drift signal was received and there has been no motion detected after a timeout period (3 minute time delay) while in Scram Timing Mode.

**Job Performance Measure****Calculate a Main Chimney Release Rate**JPM Number: RO A3Revision Number: 00Date: 3/11/2024Developed By: \_\_\_\_\_  
Instructor: Print / Sign \_\_\_\_\_ Date \_\_\_\_\_Reviewed By: \_\_\_\_\_  
SME or Instructor: Print / Sign \_\_\_\_\_ Date \_\_\_\_\_Reviewed By: \_\_\_\_\_  
Operations Representative: Print / Sign \_\_\_\_\_ Date \_\_\_\_\_Approved By: \_\_\_\_\_  
Training Department: Print / Sign \_\_\_\_\_ Date \_\_\_\_\_

## JOB PERFORMANCE MEASURE VALIDATION CHECKLIST

**NOTE:** All steps of this checklist should be performed upon initial validation.  
Prior to JPM usage, revalidate JPM using steps 9 and 13 below.

1. Task description and number, JPM description and number are identified. \_\_\_\_\_
2. Knowledge and Abilities (K/A) references are included. \_\_\_\_\_
3. Performance location specified. (in-plant, control room, simulator, or other) \_\_\_\_\_
4. Initial setup conditions are identified. \_\_\_\_\_
5. Initiating cue (and terminating cue if required) are properly identified. \_\_\_\_\_
6. Task standards identified and verified by instructor or SME review. \_\_\_\_\_
7. Critical steps meet the criteria for critical steps and are identified with an asterisk (\*). \_\_\_\_\_
8. IAW NUREG 1021 Appendix C, clearly identify the task standard (i.e., the predetermined qualitative or quantitative outcome) against which task performance will be measured. \_\_\_\_\_
9. Verify the procedure(s) referenced by this JPM reflects the current revision: \_\_\_\_\_  
 Procedure: EP-AA-110-201, ON-SHIFT DOSE ASSESSMENT Revision: 09  
 Procedure: \_\_\_\_\_ Revision: \_\_\_\_\_  
 Procedure: \_\_\_\_\_ Revision: \_\_\_\_\_
10. Verify cues both verbal and visual are free of conflict. \_\_\_\_\_
11. Verify performance time is accurate. \_\_\_\_\_
12. If the JPM cannot be performed as written with proper responses, then revise the JPM. \_\_\_\_\_
13. When JPM is initially validated, sign and date JPM cover page. For subsequent validations, sign and date below: \_\_\_\_\_

\_\_\_\_\_/\_\_\_\_\_  
 SME / Instructor (Print/Sign) Date

\_\_\_\_\_/\_\_\_\_\_  
 SME / Instructor (Print/Sign) Date

\_\_\_\_\_/\_\_\_\_\_  
 SME / Instructor (Print/Sign) Date

**Revision Record (Summary)**

<b>Revision #</b>	<b>Summary</b>
00	New JPM developed for the 2024 ILT NRC Exam IAW NUREG 1021 Rev. 12, Section ES-3.2, D.

### **SIMULATOR SETUP INSTRUCTIONS**

1. This is an Administrative JPM that may be performed in any setting where the necessary procedures and support information can be provided.
2. Manual Actions:
  - NoneMalfunctions:
  - NoneOverrides:
  - NoneRemote Functions:
  - None
3. Provide the following:
  - Unmarked copy of EP-AA-110-201 Attachment 1 pages 11 and 12.
  - Calculator
4. This completes the setup for this JPM.

### INITIAL CONDITIONS

- You are the U-2 Admin NSO.
- Unit 1 was operating at 100% rated power when an unisolable steam leak into the Turbine Building occurred. The reactor was scrammed, and considerable fuel damage has developed. QGA 400 was entered due to a high Main Chimney release rate.
- The Plant Parameter Display System (PPDS) is not available.
- Release rates are presently being monitored on the Eberline SPING Control Terminal on the 912-4 panel.
- A reading of 7.1 E+00  $\mu\text{Ci/cc}$  has just been obtained from the SPING High Range Noble Gas channel.
- The Main Chimney flow rate is presently 350 KCFM.
- This is a Drill, NOT an actual event.
- This JPM is NOT time critical.

### INITIATING CUE

Calculate the Main Chimney release rate using EP-AA-110-201, Attachment 1.

**Provide examinee with:** An unmarked copy of EP-AA-110-201, Attachment 1 pages 11 and 12.

Fill in the JPM Start Time when the student acknowledges the Initiating Cue.  
.....

#### Information For Evaluator's Use:

UNSAT requires written comments on respective step.

\* Denotes critical steps.

Number any comments in the "Comment Number" column on the following pages. Then annotate that comment in the "Comments" section. The comment section should be used to document: the reason that a step is marked as unsatisfactory, marginal performance relating to management expectations, or problems the examinee had while performing the JPM.

Comments relating to procedural, or equipment issues should be entered and tracked using the site's appropriate tracking system.

Some operations that are performed from outside of the control room may require multiple steps. These items may be listed as individual steps in this JPM. It is acceptable for the candidate to direct the local operator to perform groups of procedure steps instead of calling for each individual item to be performed.

The timeclock starts when the candidate acknowledges the initiating cue.  
.....

JPM Start Time: \_\_\_\_\_ JPM Sequence #: \_\_\_\_\_ of \_\_\_\_\_

<b><u>Task Standard:</u></b>					
Calculate the Main Chimney release rate given a SPING High Range Noble Gas channel reading of 7.1 E+00 $\mu\text{Ci/cc}$ and a Main Chimney flowrate of 350 KCFM using EP-AA-110-201 Attachment 1.					
<b><u>STEP</u></b>	<b><u>ELEMENT</u></b>	<b><u>STANDARD</u></b>	<b>SAT</b>	<b>UNSAT</b>	<b>Comment Number</b>
*JPM Step 1	Determines SPING High Range Noble Gas channel release concentration.	Obtains 7.1 E+00 $\mu\text{Ci/cc}$ from the reported reading.	<input type="checkbox"/>	<input type="checkbox"/>	—
*JPM Step 2	Determines Main Chimney flowrate.	Determines Main Chimney flowrate is 350 KCFM.	<input type="checkbox"/>	<input type="checkbox"/>	—
*JPM Step 3	Calculate the release rate.	Determines release rate from EP-AA-110-201 Attachment 1 step 5 or 6.  Release Rate ( $\mu\text{Ci/sec}$ ) = $7.1 \times 472 \times 350,000 =$ $11.7 \text{ E}+08 \mu\text{Ci/sec}$  OR  Release Rate ( $\mu\text{Ci/sec}$ ) = $7.1 \times 472 \times 350 \times 1000 =$ $11.72 \text{ E}+08 \mu\text{Ci/sec}$	<input type="checkbox"/>	<input type="checkbox"/>	—
<b>EVALUATOR NOTE: The examinee should inform you the task is complete.</b>					

JPM Stop Time: \_\_\_\_\_

.....

### JPM SUMMARY

SRRS: 3D.105 (when utilized for operator initial or continuing training)



Operator's Name: \_\_\_\_\_ Emp. ID#: \_\_\_\_\_

Job Title:  EO  RO  SRO  FS  STA/IA  SRO Cert

JPM Title: Calculate a Main Chimney Release Rate

JPM Number: RO A3

Revision Number: 00

Task Number and Title: 1700.004 - Display/read current/recorded Main Chimney low/mid/high noble gas readings at Eberline control terminal (SPING) (912-4)

1700.032 - Determine if main chimney OR RB vent radiation levels exceed posted limits of CY-QC-120-735

Task Standard: Calculate the Main Chimney release rate given a SPING High Range Noble Gas channel reading of 7.1 E+00 µCi/cc and a Main Chimney flowrate of 350 KCFM using EP-AA-110-201 Attachment 1.

K/A Number and Importance: K/A: 2.3.11

Rating: RO/SRO 3.8/4.3

Suggested Testing Environment: Anywhere

Alternate Path:  Yes  No SRO Only:  Yes  No Time Critical:  Yes  No

Reference(s):

Procedure: EP-AA-110-201, ON-SHIFT DOSE ASSESSMENT Revision: 09

Procedure: \_\_\_\_\_ Revision: \_\_\_\_\_

Procedure: \_\_\_\_\_ Revision: \_\_\_\_\_

Actual Testing Environment:  Simulator  Control Room  In-Plant  Other

Testing Method:  Simulate  Perform

Estimated Time to Complete: 5 minutes

Actual Time Used: \_\_\_\_\_ minutes

EVALUATION SUMMARY:

Were all the Critical Elements performed satisfactorily?  Yes  No

The operator's performance was evaluated against standards contained within this JPM and has been determined to be:  Satisfactory  Unsatisfactory

NOTE: Enter finalized grading, comments, and notes relevant to this evaluation in the associated TQ-AA-150-F03A/B. (See AR 4282419).

Evaluator's Name (Print): \_\_\_\_\_

Evaluator's Signature: \_\_\_\_\_ Date: \_\_\_\_\_

**Page Intentionally Left Blank**

### **INITIAL CONDITIONS**

- You are the U-2 Admin NSO.
- Unit 1 was operating at 100% rated power when an unisolable steam leak into the Turbine Building occurred. The reactor was scrammed, and considerable fuel damage has developed. QGA 400 was entered due to a high Main Chimney release rate.
- The Plant Parameter Display System (PPDS) is not available.
- Release rates are presently being monitored on the Eberline SPING Control Terminal on the 912-4 panel.
- A reading of  $7.1 \text{ E}+00 \text{ } \mu\text{Ci/cc}$  has just been obtained from the SPING High Range Noble Gas channel.
- The Main Chimney flow rate is presently 350 KCFM.
- This is a Drill, NOT an actual event.
- This JPM is NOT time critical.

### **INITIATING CUE**

Calculate the Main Chimney release rate using EP-AA-110-201, Attachment 1.

## **EBERLINE RADIATION MONITOR CONTROL TERMINAL OPERATION**

### **A. PURPOSE**

This procedure provides guidance for operating the 1/2-1740-200 and 201, Eberline Radiation Monitoring System Control Terminals and their associated Gas Activity Chart Recorders located at Panel 912-4. The Eberline Radiation Monitoring system provides controls and indications for both the Eberline DAM 3/4 Service Water and Radwaste liquid effluent monitors, and the SPING (Separate Particulate Iodine and Noble Gas) gaseous effluent monitors - Main Chimney and Reactor Building Vent SPINGS.

The performance of this procedure may also be required to provide data for completion of EP-MW-110-200.

### **B. DISCUSSION**

B.1. All Radiation Monitor channels should indicate NORMAL on the SPING print-out monitor at Center Desk. **IF** UNINITIALIZED is indicated, **THEN** that Rad Monitor is inoperable and the respective Outage Report shall be entered.

### **C. PREREQUISITES**

None.

### **D. PRECAUTIONS**

D.1. The keys on the keyboard are touch sensitive. Do **NOT** press hard when entering data.

D.2. During a low flow condition in the Radwaste Liquid Effluent Monitor System, (i.e., starting a pump), an External Fail Light and Red Alarm Light will actuate momentarily before automatically resetting and entering the operating mode.

### **E. LIMITATIONS AND ACTIONS**

E.1. **Inform** Shift Manager and Chemistry of any noted discrepancies in the Eberline Radiation Monitoring System.

- E.2. **IF** Service Water Effluent Gross Activity Rad Monitor is inoperable, **THEN perform** QCOS 1700-04.
- E.3. **IF** Radwaste Effluent Gross Activity Rad Monitor is inoperable, **THEN perform** QCOS 1700-06.
- E.4. **IF** Main Chimney Low Range Noble Gas Monitor **OR** Main Chimney Mid Range Noble Gas Monitor is inoperable, **THEN** the Main Chimney High Range Noble Gas Monitor is also inoperable.
- E.5. **IF** Main Chimney Iodine and Particulate Sampler is inoperable, **THEN perform** QCOS 1700-11.
- E.6. **IF** Main Chimney High Range Noble Gas Monitor is inoperable, **THEN perform** QCOS 1700-08.
- E.7. **IF** any of the monitors in E.2 through E.6 are inoperable, **THEN initiate** an IR.
- E.8. Control terminal to PC cables are to be connected to one Sping Control Terminal at a time. **IF** it is necessary to swap cables, **THEN contact** IT to ensure PC RS232 port is not in a faulted condition which could propagate to the control terminal.

## **F. PROCEDURE**

### **NOTE**

**See** Attachment A for general information on Control Terminal operation.

- F.1. Eberline Radiation Monitor Control Terminal Operation:
  - a. **Place** Command/Enable key to ON. \_\_\_\_\_
  - b. To determine system status, **monitor** the indicating lights and computer display (see Attachment A). \_\_\_\_\_
  - c. To determine cause of any indicating light that is lit, **enter** "[PRINT] [X] [ENTER]" on Control Terminal keypads (X = number of the light listed below.) \_\_\_\_\_

F.1.c. (cont'd)

- (1) NORMAL [1]
- (2) MAINTENANCE [2]
- (3) FAIL [3]
- (4) TREND [4]
- (5) ALERT [5]
- (6) HIGH ALARM [6]

- d. To display the status of all process channels, **enter** "[PRINT] [ENTER]" on Control Terminal keypads.

**NOTE**

The below guidelines apply to the following steps:

- "[XX-XX]" indicates the Channel Unit Number as listed on Attachment A.
- The command "[PRINT] [FILE] [ENTER]" will display the contents of the file (parameters that you asked for) at the center console.
- Symbols appearing on the PC Screen are defined as follows:

u	= Micro <b><u>OR</u></b> $10^{-6}$
b (e.g., Beta Gas)	= Beta
g (e.g., gamma liquid)	= gamma
- The SPING Control Terminal display screen can display only two lines of data; the up and down arrow keys (+/-) may be used to scroll through additional lines of data.

- e. To display the present output value and status of a specific process channel,  
**THEN:**

- (1) **Enter** "[DATA] [XX-XX] [ENTER]"
- (2) **Scroll** through the channel to the desired data.

F.1. (cont'd)

- f. To display the previous output values of a process channel, **perform** one of the following:
- (1) For the previous 24, ten-minute averages of a channel, **enter** "[HIST 10 MIN] [XX-XX] [ENTER]" and **scroll** to the desired data. \_\_\_\_\_
  - (2) For the previous 24, one-hour averages of a channel, **enter** "[HIST HOUR] [XX-XX] [ENTER]" and **scroll** to the desired data. \_\_\_\_\_
  - (3) For the previous 24, one-day averages of a channel, **enter** "[HIST DAY] [XX-XX] [ENTER]" and **scroll** to the desired data. \_\_\_\_\_

**NOTE**

To clear an alarm, the parameter must indicate < 83% of alarm setpoint and the local field unit alarm must be reset.

- g. To clear the alarm of a process channel, **enter** "[ALMCLR] [XX-XX] [ENTER]" on Control Terminal keypads. \_\_\_\_\_

**NOTE**

A source check can only be performed on SPING channels 5 and 9 and both channels of the DAM 3/4 units. Source check may cause Control Room alarms.

- h. To check a detector's response using installed sources, **enter** "[CKSRC] [XX-XX] [ENTER]". \_\_\_\_\_
- i. To display the alarm setpoints and calibration constants for a process channel:
- (1) **Unlock** Edit Enable keylock. \_\_\_\_\_

F.1.i. (cont'd)

- (2) **Enter** "[FILE] [XX-XX] [ENTER]". \_\_\_\_\_

**NOTE**

**IF** power is lost to a channel's field unit, **THEN** that channel will need to be initialized. A channel requiring initializing is indicated by a lack of status indication of that channel.

- j. **IF** malfunction occurs with Control Terminal 1/2-1740-200 and/or 1/2-1740-201 that may be addressed with a monitor "re-boot," **THEN contact** the Effluent Monitoring Chemist or the System Engineer for guidance. As an alternate point of contact for guidance, **contact** a Chemistry Supervisor. \_\_\_\_\_

**NOTE**

**WHEN** Control Terminal 1/2-1740-200 is powered down, **THEN** 912-1 E-9, RAD MON SYS A HIGH SCALE, is an expected alarm.

**WHEN** Control Terminal 1/2-1740-201 is powered down, **THEN** 912-1 F-9, RAD MON SYS B HIGH SCALE, is an expected alarm.

- (1) To power down Control Terminal 1/2-1740-200 and/or 1/2-1740-201, the ON/OFF switch at the back of the terminal is used. **WHEN** re-booting a single control terminal, **THEN allow** it to be de-energized at least approximately five seconds. \_\_\_\_\_
- (2) **Allow** up to two minutes following control terminal re-boot to determine if the malfunction has cleared. \_\_\_\_\_

F.1.j. (cont'd)

- (3) **IF** re-booting both monitors simultaneously, **THEN** turn on Control Terminal 1/2-1740-200 (unless directed otherwise) **FIRST** and **ensure** that it has provided a status print-out prior to turning on the other control terminal.

**NOTE**

**IF** Control Terminal 1/2-1740-200 and/or 1/2-1740-201 is "re-booted", **THEN** this is to be documented in the IR process and "re-boot" log on the backside of the Control Terminal.

- k. **IF** a channel requires initializing, or problems arise beyond the scope of this procedure, **THEN** contact the Effluent Monitoring Chemist, a Chemistry Supervisor, or the System Engineer.

- l. **Place** Command/Enable key to OFF.

F.2. General Information about the Main Chimney SPING and Reactor Building Vent SPING Gas Activity Recorders:

- a. Recorder 1/2-1740-202, MN CHIMNEY GAS ACTIVITY low range noble gas scale (red pen), mid range noble gas scale (grn pen), and high range noble gas scale (blu pen) record  $\mu\text{Ci/cc}$  activity and may be used as a backup source of data in the calculation of Main Chimney Noble Gas Release per CY-QC-120-730.
- b. Recorder 1/2-1740-203, RX BLDG STACK GAS ACTIVITY low range noble gas scale (green pen), mid range noble gas scale (blue pen), and high range noble gas scale (red pen) record  $\mu\text{Ci/cc}$  of Reactor Vent Noble Gas Activity and this data is used in the calculation of Reactor Vent Noble Gas Release per CY-QC-120-731.

## **G. ATTACHMENTS**

- G.1. Attachment A: General Information Required for Control Terminal Operation.

## **H. REFERENCES**

### **H.1. Technical Specifications:**

- a. TS 5.5.1, Offsite Dose Calculation Manual.

### **H.2. P&IDs:**

None.

### **H.3. Drawings:**

None.

### **H.4. Manuals:**

- a. VETI C0005, Technical Manual for CT-2 & CT-2B.

### **H.5. Procedures:**

- a. EP-MW-110-200, Dose Assessment.
- b. CY-QC-120-730, Main Chimney Noble Gas Release.
- c. CY-QC-120-731, Reactor Vent Noble Gas Release Calculations.
- d. CY-QC-120-735, Main Chimney & Reactor Vent Noble Gas Release Rate Action Levels.
- e. QCOS 1700-04, Service Water Effluent Gross Activity Radiation Monitor Outage Report.
- f. QCOS 1700-06, Liquid Radwaste Effluent Gross Activity Radiation Monitor Outage Report.
- g. QCOS 1700-08, Main Chimney High Range Noble Gas Monitor Outage Report.
- h. QCOS 1700-11, Main Chimney Iodine and Particulate Sampler Outage Report.

### **H.6. UFSAR:**

- a. Section 11.5.2.7, Process Liquid Monitoring Subsystem.

H.7. **Commitments:**

None.

H.8. **Others:**

- a. QCPWG (Procedure Writers Guide), Vol 3.

**ATTACHMENT A (Page 1 of 3)**  
**GENERAL INFORMATION REQUIRED FOR  
CONTROL TERMINAL OPERATION**

1. The seven indicating lights at the front of the Control Terminal indicate the following status conditions of all process radiation channels monitored by Eberline Radiation Monitoring System:
  - a. NORMAL (green) - One or more channels in normal status.
  - b. MAINTENANCE (white)- One or more channels in Flush, Check Source, or Calibrate.
  - c. FAIL (amber) - One or more channels failed on low flow, low counts, communication failure, or power loss.
  - d. TREND (amber) - One or more channels in trend alarm status.
  - e. ALERT (amber) - One or more channels in high alarm condition.
  - f. HIGH ALARM (red) - One or more channels in high-high alarm status. (Pushbutton is depressed to acknowledge alarm.)
  - g. RED LIGHT - Will light upon change in status of any channel or during a high-high alarm condition.
2. Specific information about the process radiation channels can be requested by a typed in "command" via keypads within the Control Terminal drawer.
  - a. The upper keypad is the instruction pad and the lower keypad is the data pad.
  - h. All commands begin with a single entry via the instruction pad followed by an entry (or entries) via the data pad, then terminated by the ENTER key.

**ATTACHMENT A (Page 2 of 3)**  
**GENERAL INFORMATION REQUIRED FOR  
CONTROL TERMINAL OPERATION**

3. Each process radiation channel is assigned a "unit" number (two 2-digit numbers separated by a hyphen) to enable the channel's selection via the terminal keypads. When entered, the unit number must include the hyphen.

<u>PROCESS CHANNEL</u>	<u>UNIT NUMBER</u>	<u>UNITS</u>
(Rx Vent SPING)		
Rx Vent Low Range Noble Gas	01-05	µCi/cc
Rx Vent Mid Range Noble Gas	01-07	µCi/cc
Rx Vent High Range Noble Gas	01-09	µCi/cc
(Chimney SPING)		
Chimney Low Range Noble Gas SPING	03-05	µCi/cc
Chimney Mid Range Noble Gas SPING	03-07	µCi/cc
Chimney High Range Noble Gas	03-09	µCi/cc
(DAM 3/4 Liquid)		
Radwaste Effluent	10-01	cpm
Unit 1 Service Water Effluent	11-01	cpm
Unit 2 Service Water Effluent	12-01	cpm

4. Any change in status of the process channels will be shown on the computer display.
5. Each key depressed is displayed on the Control Terminal display screen above the keypads. An entry error can be corrected by depressing the [RUBOUT] key.
6. The Control Terminal display screen can display up to two lines of data; the up and down arrow keys then may be used to scroll through additional lines of data.
7. The command "[PRINT] [FILE] [ENTER]" will output the contents of display screen to the computer display.
8. Use of the black/white and green/white keys require the Command Enable keylock to be unlocked.
9. Use of the black/green keys require the Edit Enable keylock to be unlocked.

**ATTACHMENT A (Page 3 of 3)**  
**GENERAL INFORMATION REQUIRED FOR**  
**CONTROL TERMINAL OPERATION**

10. Process channel status is indicated by any of the following conditions:

<u>MARGIN</u> <u>FLAG</u>	<u>STATUS</u> <u>WORD</u>	(Status Meaning)
*	(none)	Channel is not initialized.
*	CK SRCE	Channel placed in Check Source mode.
*	CALIB	Channel has CALIBRATE switch on.
*	MAINT	Channel has MAINTENANCE switch on.
*	FLUSH	Channel placed in Flush mode.
*	STANDBY	Channel placed in Standby mode (disables alarm).
F	FAIL EX	Channel sample flow is beyond acceptable limits.
F	FAIL LO	Channel failed downscale.
F	FAIL HI	Channel failed upscale.
*	ALM OFF	Channel alarm function is disabled.
A	HI ALM	Channel exceeds High Alarm setpoint. (Will clear when output value decreases below 83% of alarm setpoint.)
A	FLO ALM	Channel sampling system trouble.
A	ALT ALM	Channel in Alert Alarm status. (Will clear when output value decreases below 80% of alarm setpoint.)
(none)	NORMAL	Channel is in normal status.
(none)	UNINITIALIZED (on Center Desk monitor)	Channel is inoperable.

**Attachment 1**  
**Alternate Release Rate Determination Methodologies**

In the event a release point using a release rate (uCi/sec) is unavailable, either due to the loss of the plant computer point or installed instrument, it may be possible to calculate a release rate that can be used in URI.

1. **LOCATE** the affected site and the applicable Release Point in Table 1.1.
2. **CONTACT** the affected control room.

NOTE: Monitors for each release point in Table 1.1 are listed in order from most sensitive to least sensitive.

3. **OBTAIN** the release concentration in uCi/cc using the lowest range (most sensitive) instrument that is available and on-scale.
4. **OBTAIN** the release point flow rate.
5. If the flow rate is in CFM, then **CALCULATE** the release rate using the following equation:

$$ReleaseRate_{(uCi/sec)} = uCi/cc * 472 * CFM$$

6. If the flow rate is in KCFM, then **CALCULATE** the release rate using the following equation:

$$ReleaseRate_{(uCi/sec)} = uCi/cc * 472 * KCFM * 1000$$

Table 1.1

Release Rate Conversion Points

Site	Release Point	Monitor Description	Monitor ID	Units	Flow Rate ID	Units
Braidwood	Unit 1 Vent Stack	Wide Range Gas	Low Range: 1PB128 (a) Hi Range: 1PDD428 (a)	uCi/cc	VA019 (a)	CFM
	Unit 2 Vent Stack	Wide Range Gas	Low Range: 2PB128 (a) Hi Range: 2PB428 (a)	uCi/cc	VA020 (a)	CFM
(a) These points are available from the RM-11 Terminal in the Control Room.						

**Attachment 1  
Alternate Release Rate Determination Methodologies**

**Table 1.1**

**Release Rate Conversion Points**

Site	Release Point	Monitor Description	Monitor ID	Units	Flow Rate ID	Units
Byron	Unit 1 Vent Stack	Wide Range Gas	Low Range: 1PB128 (a) Hi Range: 1PD428 (a)	uCi/cc	VA019 (a)	CFM
	Unit 2 Vent Stack	Wide Range Gas	Low Range: 2PB128 (a) Hi Range: 2PB428 (a)	uCi/cc	VA020 (a)	CFM
	(a) These points are available from the RM-11 Terminal in the Control Room.					
Site	Release Point	Monitor Description	Monitor ID	Units	Flow Rate ID	Units
Clinton	HVAC Stack	HVAC AXM NG	Low Range: 0R1X-PR001 0R1X-PR002 Mid Range: 0R1X-PR012 Hi Range: 0R1X-PR012	uCi/cc	0U1X-PR051 Ch.6	CFM
	SGTS Stack	SGTS AXM NG	Low Range: 0R1X-PR003 0R1X-PR004 Mid Range: 0R1X-PR008 Hi Range: 0R1X-PR008	uCi/cc	0U1X-PR051 Ch.1	CFM
Site	Release Point	Monitor Description	Monitor ID	Units	Flow Rate ID	Units
Dresden	Unit 2/3 Main Chimney	Chimney SPING	Low Range: 05-05 (a) Mid Range: 05-07 (a) Hi Range: 05-09 (a)	uCi/cc	05-10 (a)	KCFM
	Unit 2/3 Reactor Building Vent Stack	Rx Vent SPING	Low Range: 01-05 (a) Mid Range: 01-07 (a) Hi Range: 01-09 (a)	uCi/cc	01-10 (a)	KCFM

(a) These points are available from the Eberline Control Terminal (CT) in the corresponding Control Room or directly from the corresponding SPING.

**Attachment 1**  
**Alternate Release Rate Determination Methodologies**

**Table 1.1**

**Release Rate Conversion Points**

Site	Release Point	Monitor Description	Monitor ID	Units	Flow Rate ID	Units
Ginna	Plant Vent	Plant SPING	R14A Plant Vent Noble Gas <sup>(a)</sup>	uCi/cc	See Attachment 4	CFM
	Containment Vent	CV Vent SPING	R12A CNTMT Vent Noble Gas <sup>(a)</sup>	uCi/cc	See Attachment 4	CFM
<sup>(a)</sup> These points are available from the corresponding SPING.						
Site	Release Point	Monitor Description	Monitor ID	Units	Flow Rate ID	Units
LaSalle	Station Vent Stack	Wide Range Gas	Low Range: RM-23 Lo <sup>(a)</sup> Mid Range: RM-23 Mid <sup>(a)</sup> Hi Range: RM-23 Hi <sup>(a)</sup>	uCi/cc	RM-23 Mon 029 <sup>(a)</sup> OFR-VR019 <sup>(c)</sup>	KCFM
	SBG T Stack	Wide Range Gas	Low Range: RM-23 Lo <sup>(b)</sup> Mid Range: RM-23 Mid <sup>(b)</sup> Hi Range: RM-23 Hi <sup>(b)</sup>	uCi/cc	1/2 FR-VG009 <sup>(d)</sup>	KCFM
<sup>(a)</sup> Reading obtained from Control Room Panel 0PM14J. <sup>(b)</sup> Reading obtained from Control Room Panel 0PM15J. <sup>(c)</sup> Reading obtained from Control Room Panel 1PM06J. <sup>(d)</sup> Reading obtained from Control Room Panel 1/2PM07.						
Site	Release Point	Monitor Description	Monitor ID	Units	Flow Rate ID	Units
Limerick	North Stack	Wide Range	Low Range: RR-26-076 Pt.3	uCi/cc	RE-026-076 <sup>(a)</sup>	CFM
			Mid Range: RR-26-076 Pt.2 Hi Range: RR-26-076 Pt.1	RE-026-075 <sup>(a)</sup>		
<sup>(a)</sup> These points are only available from the RM-11 Terminal in the TSC or Control Room. To obtain the information: 1) <b>SELECT</b> the WRAM (RE-026-076) or North Stack Normal (RE-026-075) point. 2) <b>SELECT</b> Monitor Detail. 3) <b>SELECT</b> the Total Effluent Flow Rate in scfm.						

**Attachment 1**  
**Alternate Release Rate Determination Methodologies**

**Table 1.1**

**Release Rate Conversion Points**

Site	Release Point	Monitor Description	Monitor ID	Units	Flow Rate ID	Units	
Nine Mile Point Unit 2	Unit 2 Stack	Stack 2RMS-SKD170B	Channel 1 - Low Range	UCI/cc	Use Form EP-AA-110-200-F-06	KCFM	
			Channel 2 - Mid Range				
			Channel 3 - High Range				
Peach Bottom	Main Stack	Wide Range	Low Range: RI-0-17-050BL	UCI/cc	FT-0470A	KCFM	
			Mid Range: RI-0-17-050BM		FT-0470B		
			High Range: RI-0-17-050BH				
Site	Release Point	Monitor Description	Monitor ID	Units	Flow Rate ID	Units	
			U2 Reactor Building Vent (a)	Wide Range	UCI/cc	FT-2805A FT-2805B	KCFM
			U3 Reactor Building Vent (b)	Wide Range	UCI/cc	FT-3805A FT-3805B	KCFM
(a) These points are available in PMS as PA019, PA020, and PA021.							
(b) These points are available in PMS as PA319, PA320, and PA321.							
Quad Cities	Main Chimney	Chimney SPING	Low Range: 03-05 (a)	UCI/cc	RE 0-5740-109	KCFM	
			Mid Range: 03-07 (a)				
			Hi Range: 03-09 (a)				
Site	Release Point	Monitor Description	Monitor ID	Units	Flow Rate ID	Units	
			Reactor Building Vent Stack	Rx Vent SPING	UCI/cc	Assume 48K cfm per running fan	KCFM
(a) These points are available from the Eberline Control Terminal (CT) or directly from the corresponding SPING.							