

# **Irradiation and corrosion testing of laser powder bed fusion-manufactured materials in the AMMT program**

Andrea Jokisaari

NRC Workshop on AMTs for Nuclear Applications, October 24-26, 2023, Rockville, MD

# We are an interlaboratory collaborative research team

**Rongjie Song**

**Drew Johnson**

**Andrea Jokisaari**

**Wei-Ying Chen**

**Yiren Chen**

**Argonne NATIONAL LABORATORY**

**INL Idaho National Laboratory**

**OAK RIDGE National Laboratory**

**TS Byun**

**Stephen Taller**

**Tim Lach**

**Caleb Massey**

# What's the big deal for environmental effects testing of additively manufactured materials?

- **Material evolution and lifetime in harsh advanced reactor environments must be part of a reactor material development and qualification program**
  - Irradiation, corrosion, and high-temperature loading conditions
  - Complex damage processes that are often coupled phenomena
  - Experiments can be time-consuming and costly
- **Evaluating irradiation performance of new materials is one of the most critical technical hurdles for their rapid adoption in nuclear energy systems**
- **AM materials have challenge of process variability: how much does that matter?**
  - Existing qualification regime will be prohibitive
- **Goal: Rapid and effective qualification of the effect of process variability on performance and degradation of AM materials in reactor environments**

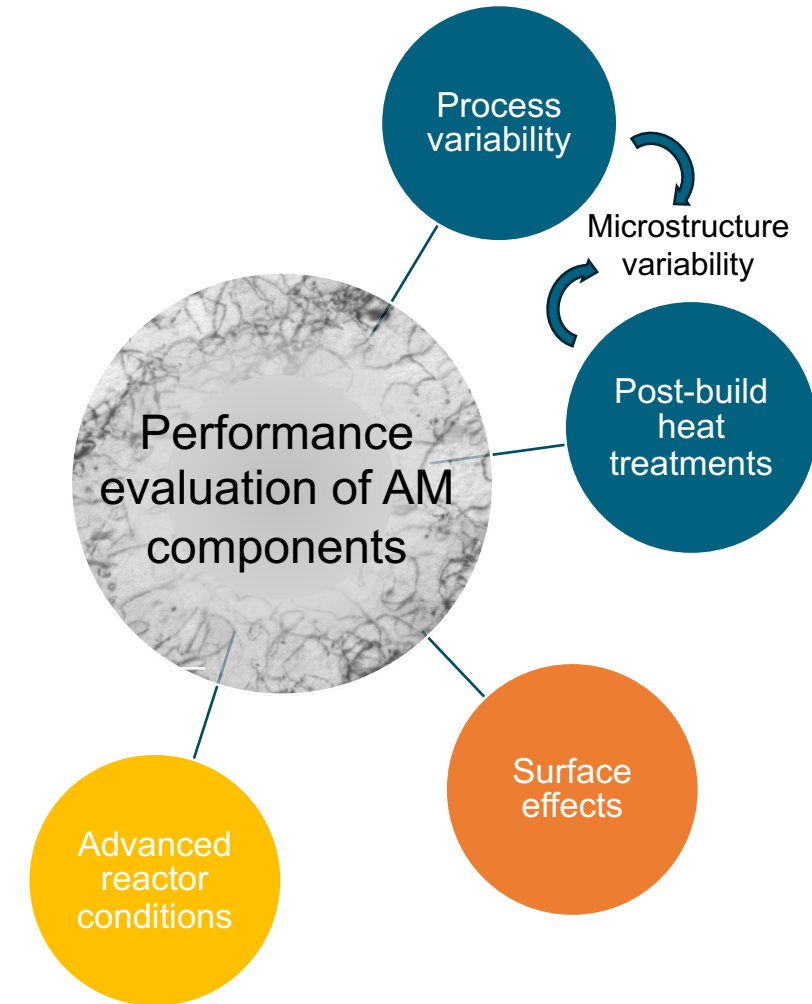



# The AMMT solution: an integrated environmental effects testing strategy for AM 316H

- ★ Build
- ★ Ions
- ★ Neutrons
- ★ Corrosion

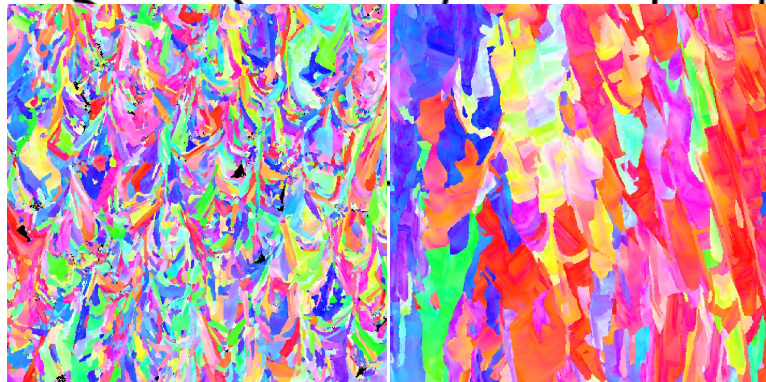
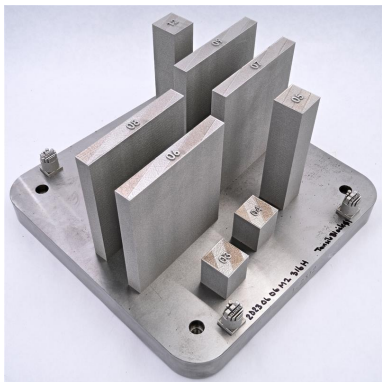
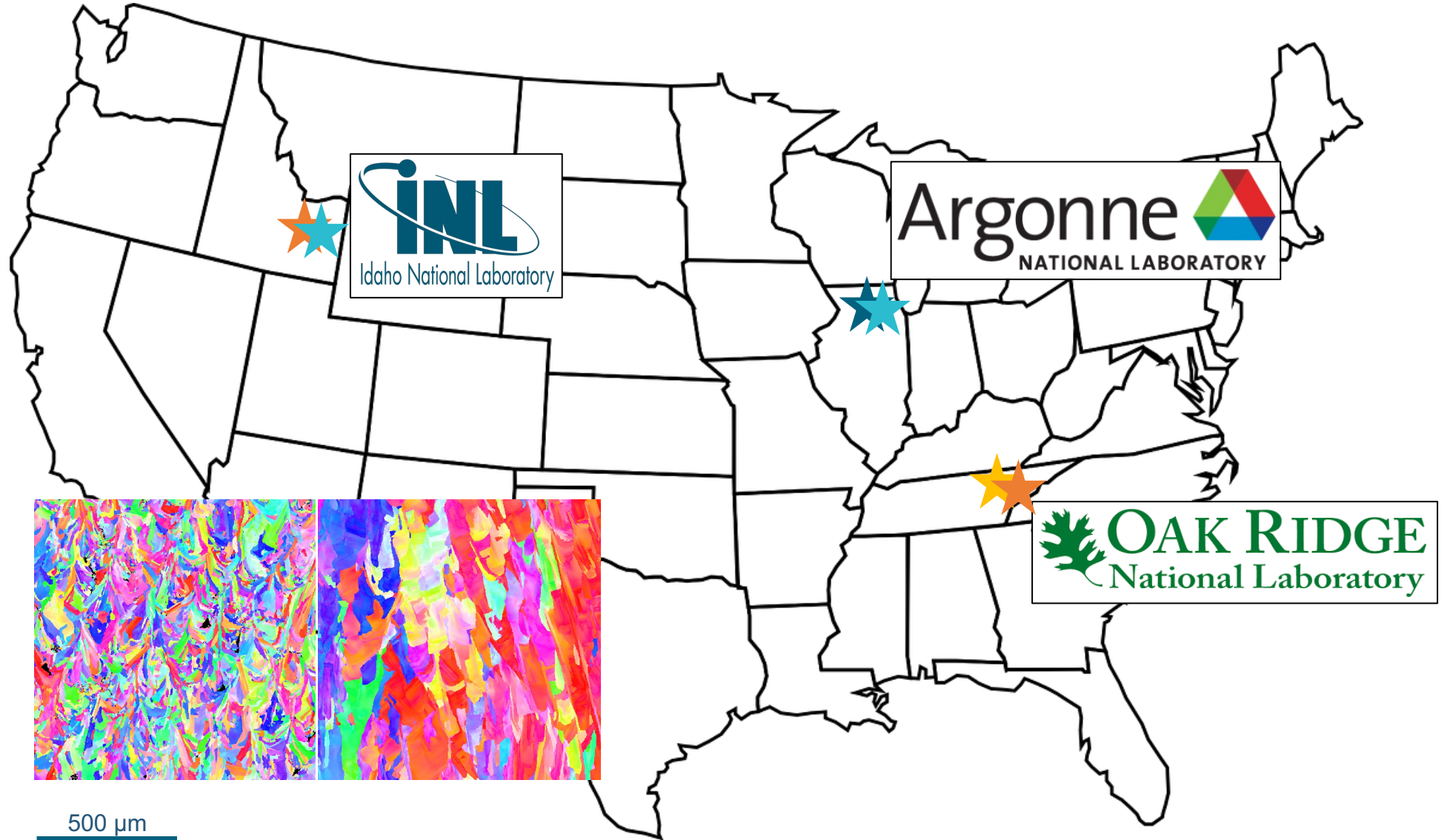

500  $\mu\text{m}$



# Corrosion Testing of AM Materials

## Corrosion is a natural process of removing useful material thickness

- Uniform
- Localized
- Erosion
- Dealloying
- Environment-assisted cracking

## Corrosion costs nuclear industry ~\$4B/yr

- Each reactor type has its own corrosion issues
- Elevated temperature + intense irradiation are common conditions for all advanced reactor types

## Unique features of AM materials may impact corrosion behavior

- Influence of surface roughness, porosity, residual stresses
- Influence of melt pool boundaries
- Influence of microstructural anisotropy

**Some types of corrosion are difficult to detect but have severe consequences of critical importance**

INL/RPT-23-74687



## Corrosion testing needs and considerations for additively manufactured materials in nuclear reactors

September 2023

Andrea Jokisaari<sup>1</sup>, Yiren Chen<sup>2</sup>, Thomas Hartmann<sup>3</sup>, Vineet Joshi<sup>3</sup>, Isabella van Rooyen<sup>3</sup>, Rongjie Song<sup>1</sup>, and Jonathan Wierschke<sup>3</sup>

<sup>1</sup>Idaho National Laboratory

<sup>2</sup>Argonne National Laboratory

<sup>3</sup>Pacific Northwest National Laboratory



INL is a US Department of Energy National Laboratory operated by Battelle Energy Alliance, LLC

# AMMT program corrosion testing strategy on AM 316 prioritizes advanced reactor concerns

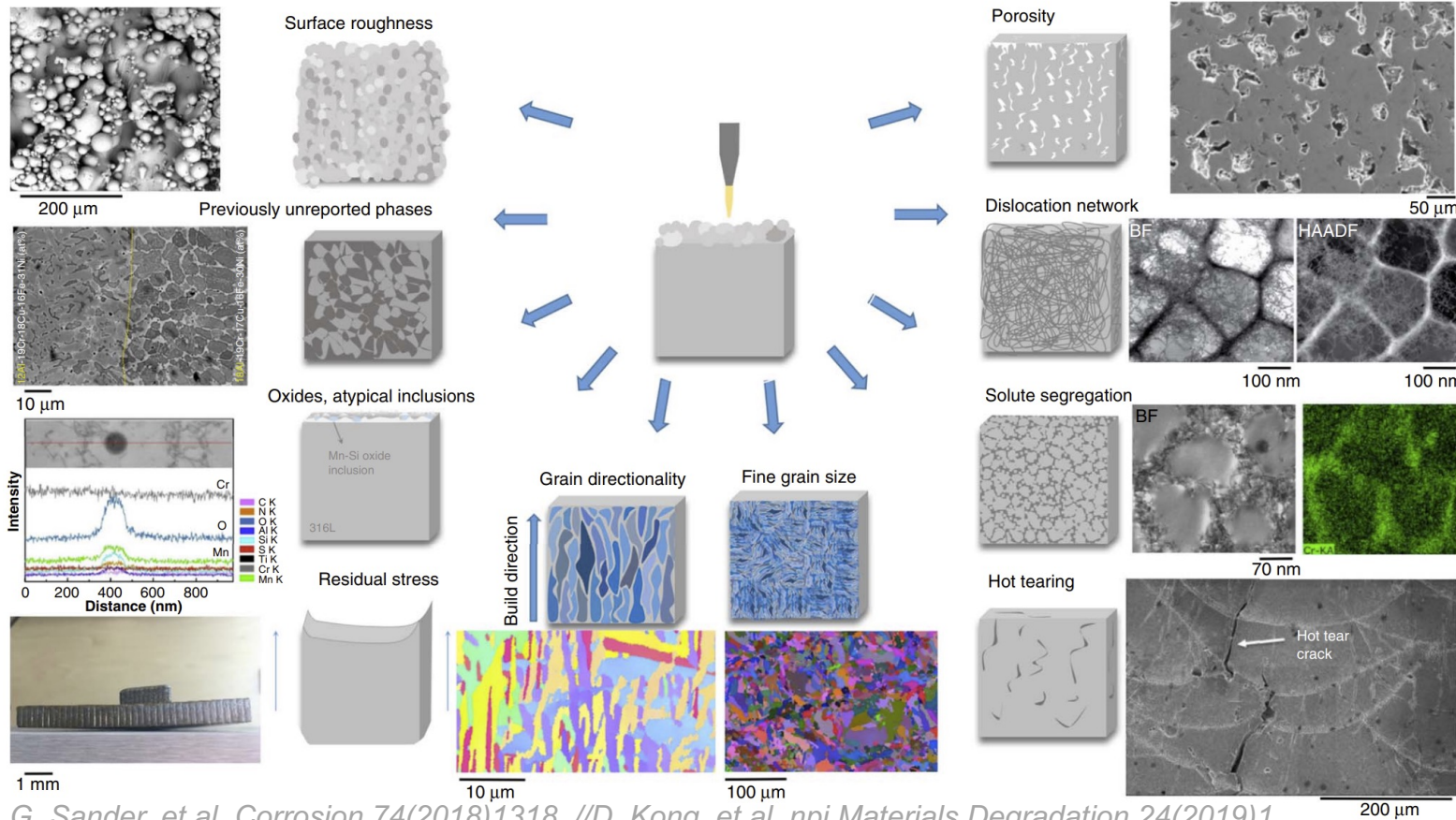

G. Sander, et al. *Corrosion* 74(2018)1318. //D. Kong, et al. *npj Materials Degradation* 24(2019)1.

- **Corrosion systems:**
  - Liquid sodium
  - Molten chloride salts
- **Two-surface tests:**
  - As-built surfaces
  - Machined smooth surfaces
- **Macroscopic behavior:**
  - Weight gain/loss
- **Microscopic behavior:**
  - Localized effects (leaching, phase changes...)
- **Staged approach:**
  - Unirradiated material
  - PIE corrosion of irradiated material
  - Prototypical testing *in situ*

**Corrosion resistance of stainless steel comes from its passive film**

# AMMT selects the right tool for the job in evaluating irradiation effects on material performance

- **AMMT uses its expertise to select the right tool for the job**
  - High level conceptualization of radiation testing for design achievement
  - Timelines to obtain data (accelerated vs prototypical)

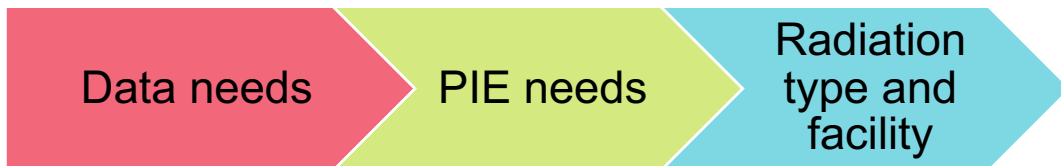
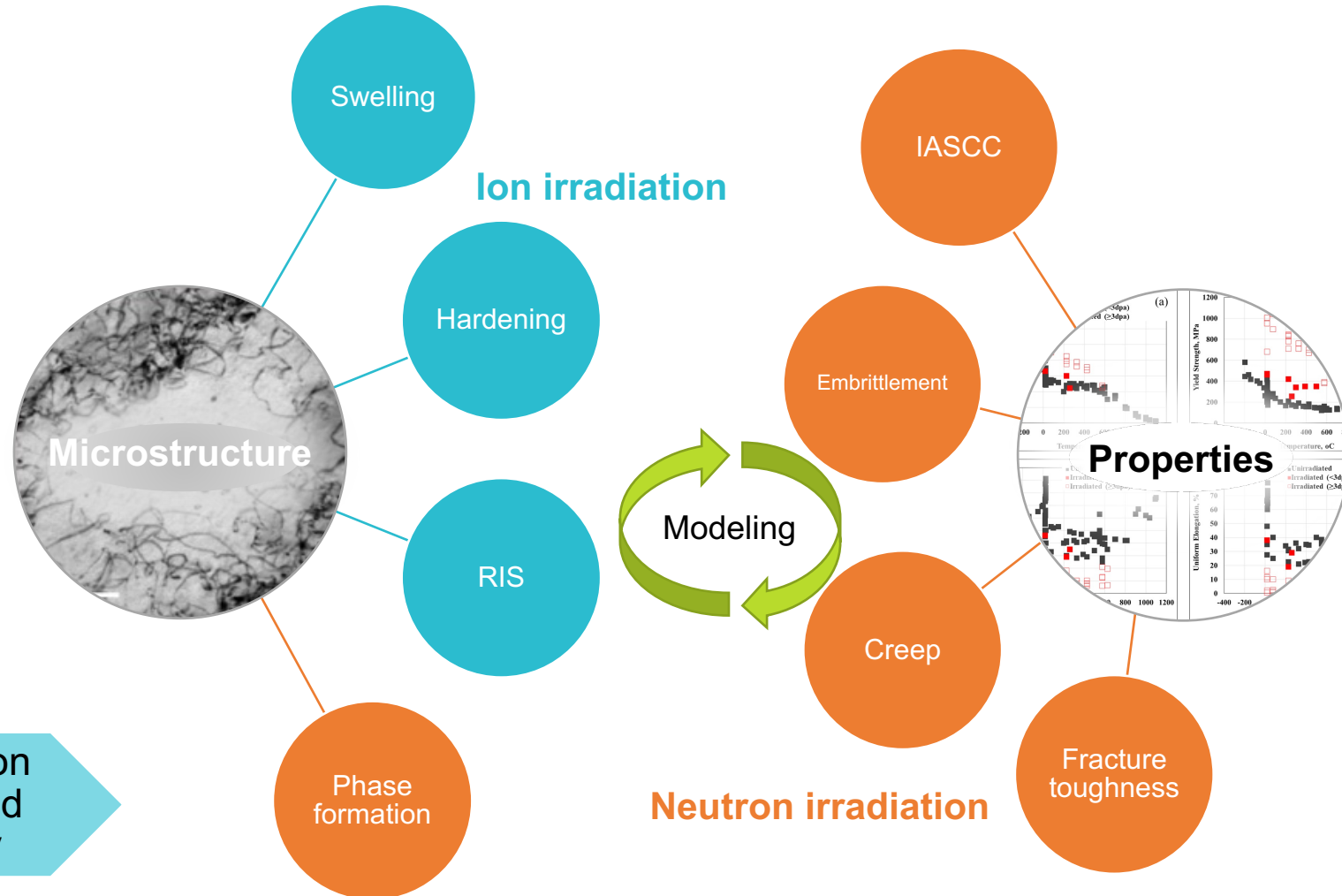



# Neutron irradiation campaigns are integrated to provide rapid insight into AM processing impacts on 316H

- **Neutron irradiations are designed to:**
  - Provide rapid screening of AM processing effects (microstructure variability) on radiation response behavior (microstructure and mechanical properties)
  - Provide targeted neutron irradiation information for promoting the regulatory acceptance of the combined use of ion and neutron irradiation data
- **Integrated campaign catering to the strengths of both High Flux Isotope Reactor (ORNL) and Advanced Test Reactor (INL) and post-irradiation examination facilities**
  - Link irradiation data of the selected materials to AM builds with high-pedigree digital signatures and well-characterized local microstructures
  - Leveraging standard capsule designs to make neutron irradiations faster and cheaper

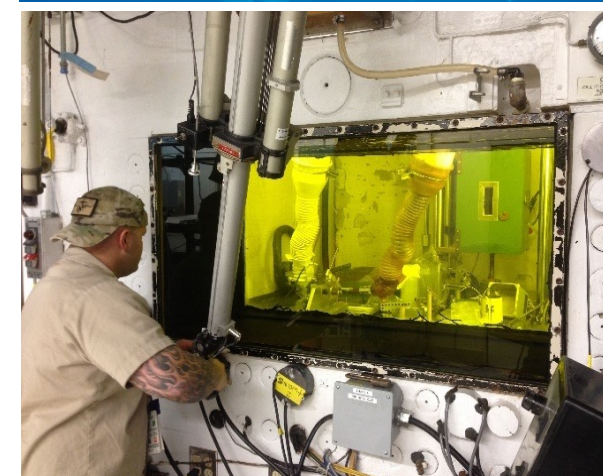

# AM 316H irradiation campaign provides useful information to industry quickly

- **Focusing primarily on neutron irradiation conditions in the range of interest for deployment of AM 316H in advanced reactors**
  - 400 °C – 600 °C
  - 1 to 10 dpa
  - LPBF, wire-DED, and wrought material
- **Producing data of interest for advanced reactors and multiple specimens in each condition for data replication and statistical variation**
  - Uniaxial tensile tests (SSJ specimens) performed at irradiation temperature and room temperature
  - Fracture toughness tests (bend bars)
  - Creep tests (SSJ specimens) of irradiated material in hot cell
  - Creep crack growth and fatigue (compact tension specimens) of irradiated material in hot cell
  - Microstructure characterization using TEM disks, FIB lift-outs, atom probe and hardness testing of material from grip areas of other specimens

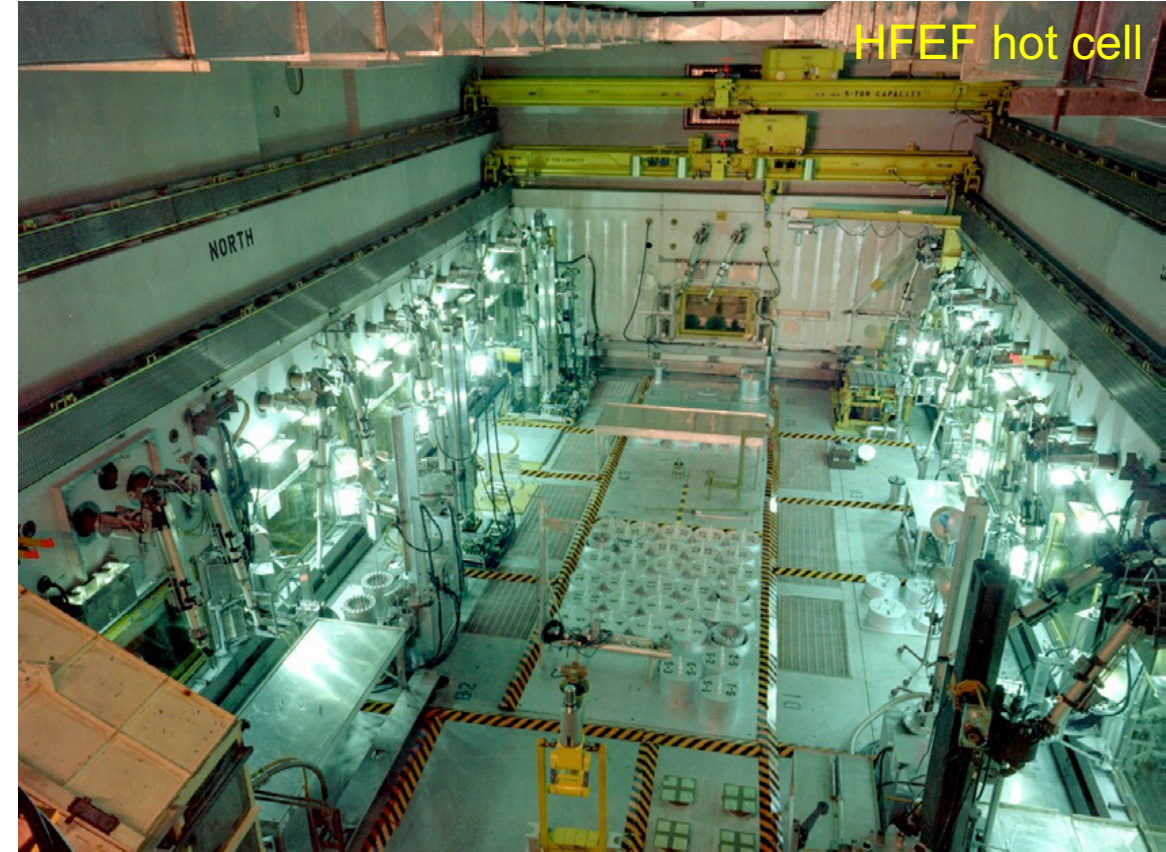



# Near-term HFIR irradiations evaluate post-irradiation strength, ductility, and fracture toughness

- Evaluate impact of material (build), orientation, and thermomechanical treatment
- Tensile testing and fracture toughness testing evaluates:
  - $T_{irr} = 400\text{ °C}$  and  $600\text{ °C}$
  - 2 dpa and 10 dpa
  - Stress-relieved, solution annealed
  - Chevron and columnar microstructures
  - Loading in the build and transverse orientations
  - Wrought material
- Two specimens for each unique AM combination
- Additional tests at  $650\text{ °C}$  will investigate susceptibility to high-temperature He embrittlement
- Additional tests at  $475\text{ °C}$  from 2 dpa – 30 dpa to test cavity swelling

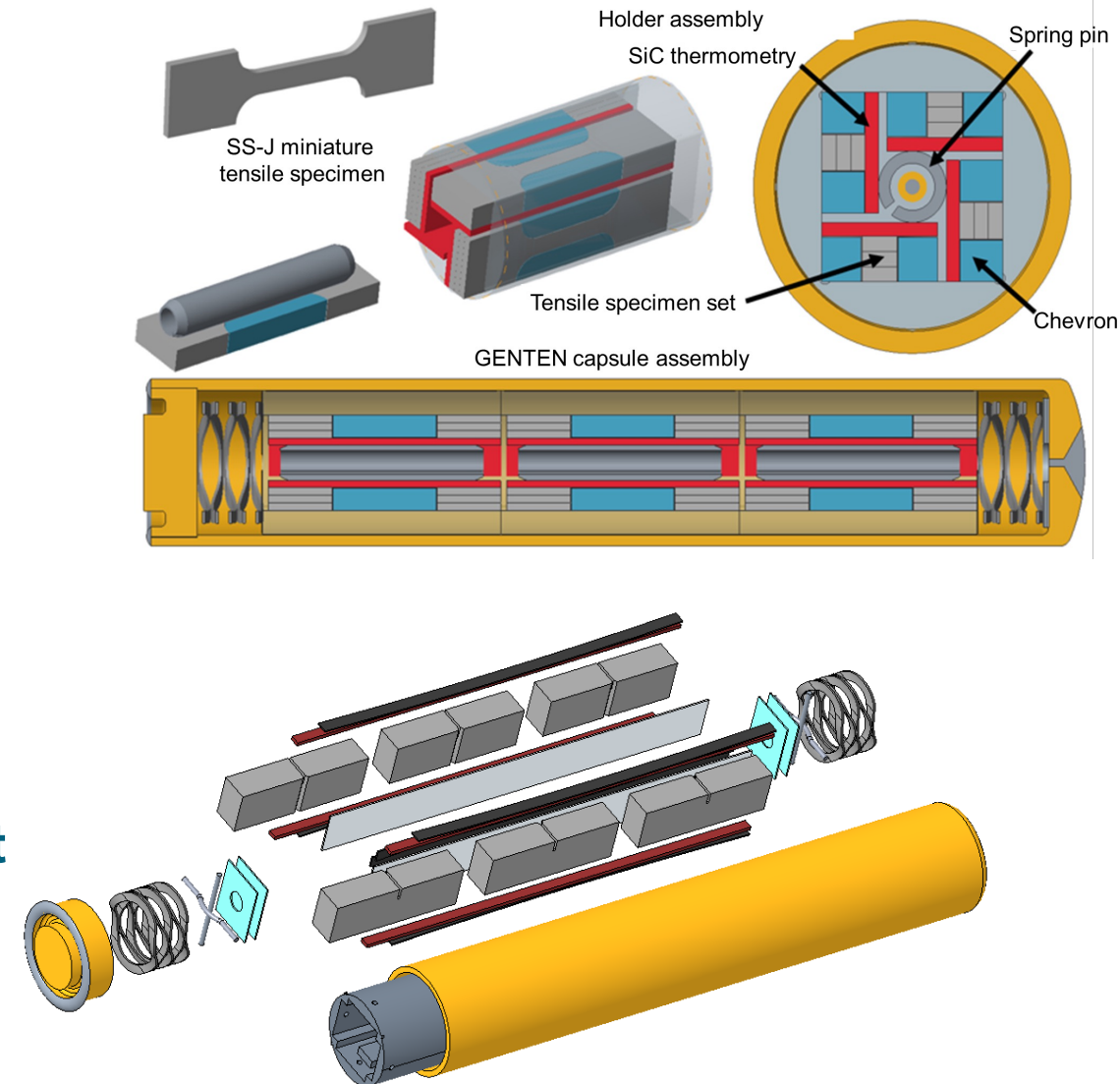



# ATR irradiations provide information specific to advanced reactor concerns

- Evaluate impact of material (build), orientation, thermomechanical treatment, and neutron spectrum by comparison to HFIR data
- Tensile, creep, creep-fatigue, creep crack growth testing evaluates:
  - $T_{irr} = 400\text{ °C}$  and  $600\text{ °C}$
  - 1 dpa and 2 dpa
  - Subset of material tested at HFIR
- Duplicate specimens for each unique AM combination
- Novel PIE leveraging the upcoming SPL
- Tensile testing at 2 dpa provides overlap with HFIR

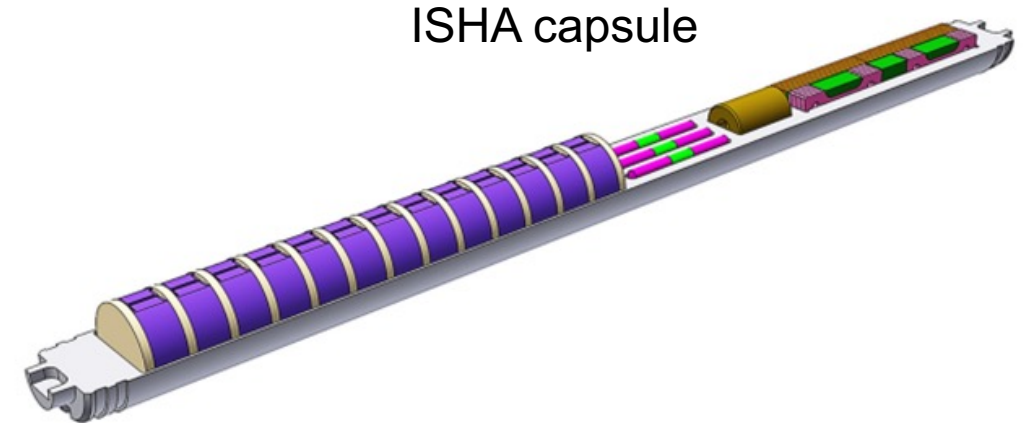

ISHA capsule

Structural Properties Laboratory

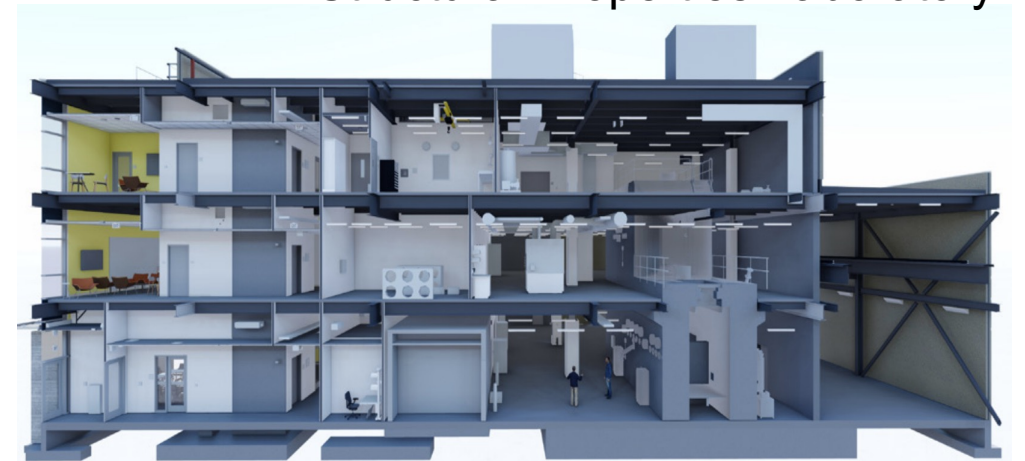

# HFIR irradiation results on AM 316L reveal hardening and ductility behaviors

- Evaluate impact of material (build), orientation, and thermomechanical treatment
- Tensile testing and PIE evaluates:
  - $T_{irr} = 300\text{ }^{\circ}\text{C}$  and  $600\text{ }^{\circ}\text{C}$  (targeted)
  - 0.2, 2, and 10 dpa
  - As-built, stress-relieved, and solution annealed material and wrought conventional
  - Sampling from different locations with the AM build (stress-relieved)

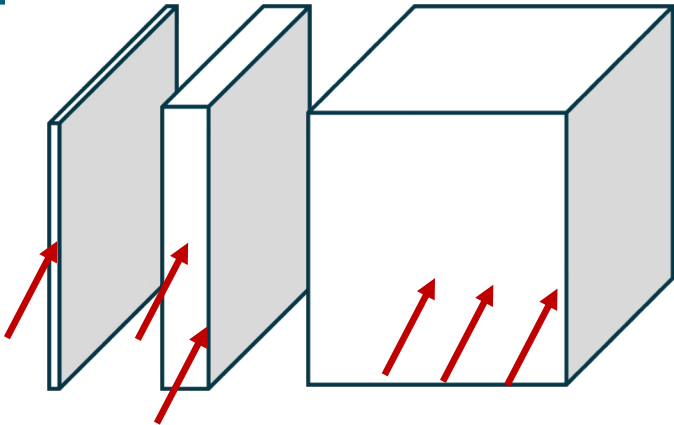

**Sampling Location**

- 1.5mm plate layer
- 5mm block center layer
- 5 mm block surface layer
- 40mm cube 10mm from surface
- 40mm cube center layer
- 40mm cube surface layer

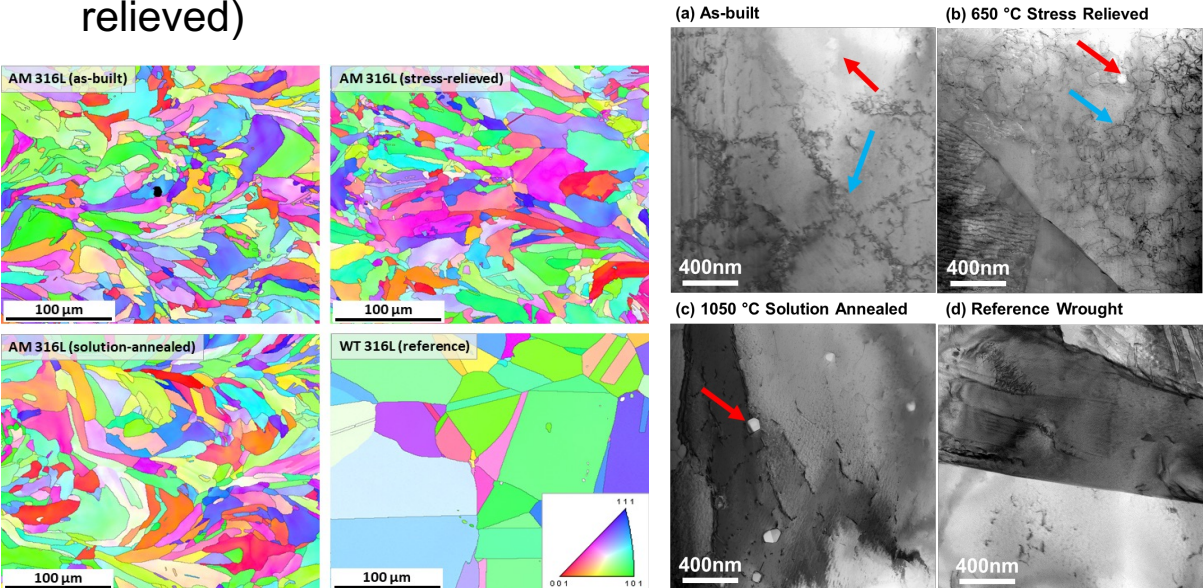
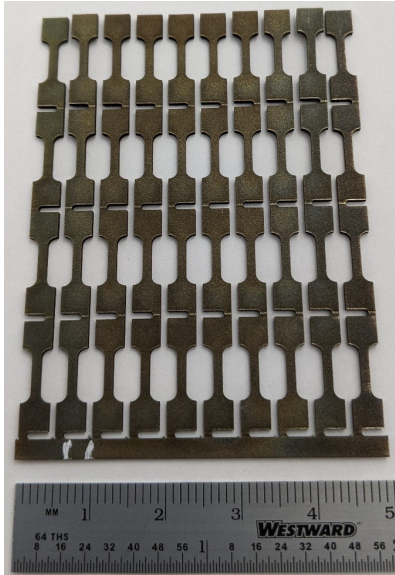

# Testing after neutron irradiation reveals degree of effect of process variability on tensile behavior

- **Variations in UTS and uniform elongation are similar after 600 °C and 300 °C irradiation**
  - Different defect mobilities: vacancies and interstitials at 600 °C, interstitials only at 300 °C
  - No consistent dependency on sampling location
  - As-built material exhibited softening, stress-relieved appeared to provide the best combination of properties
- **Complete loss of uniform elongation at 300 °C**

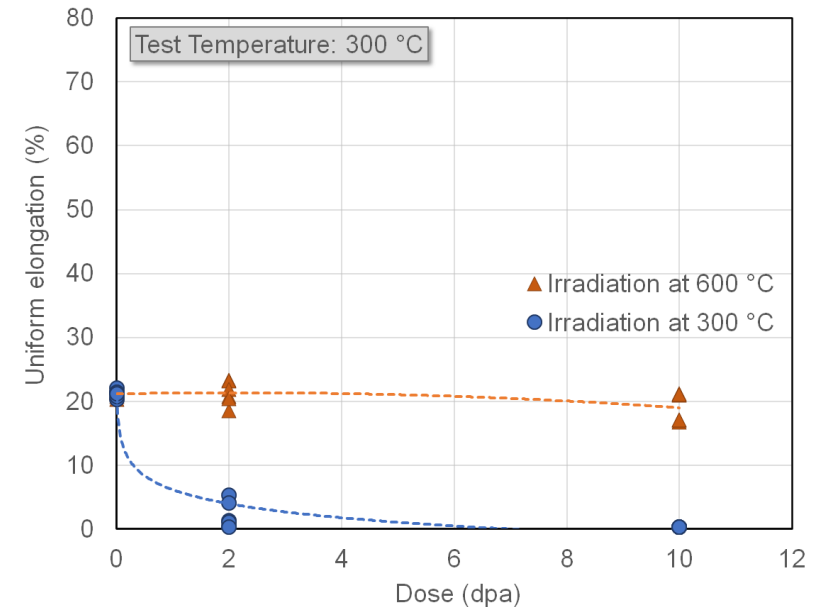
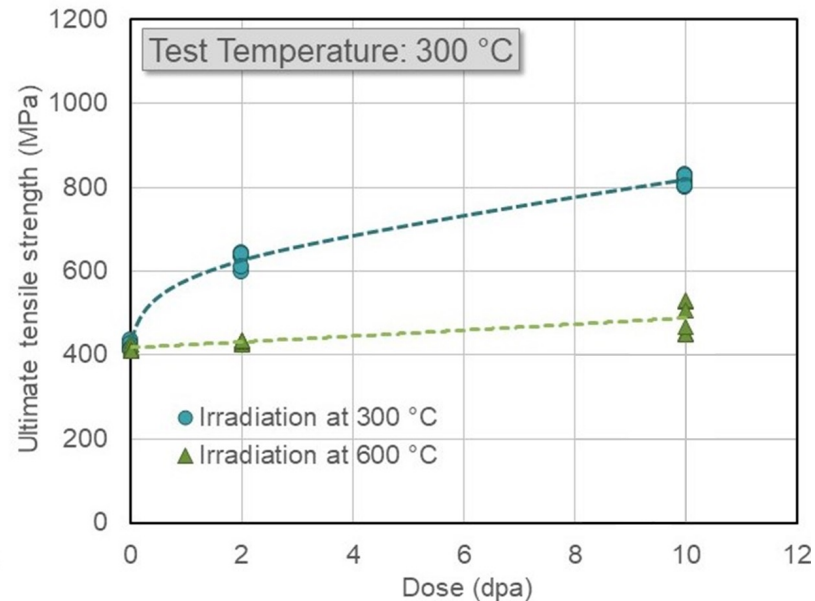
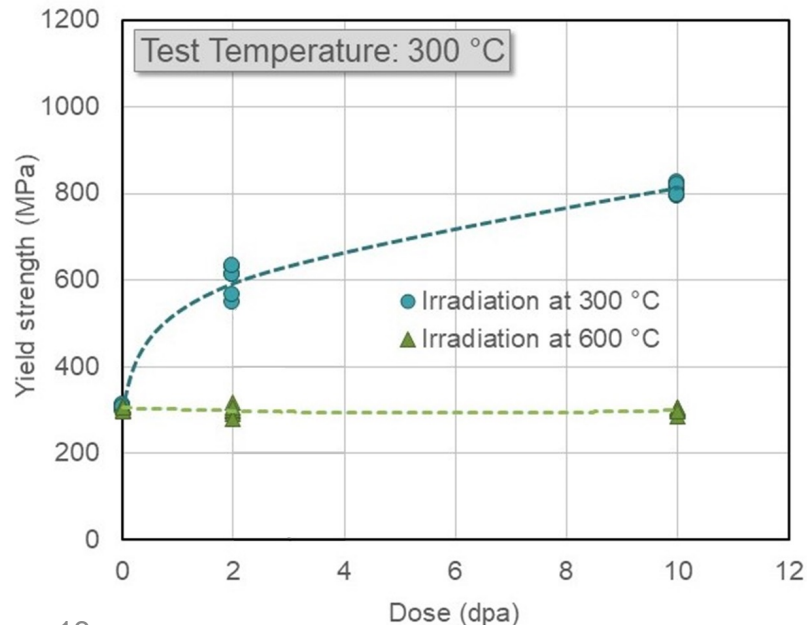



# Ion irradiation provides initial insights into microstructure evolution under irradiation for AM 316L and AM 316H

- **Ion irradiations can:**
  - Provide rapid screening of materials evolution under a wide parameter array
  - Create cascade damage that can be linked to prototypical neutron irradiation conditions via microstructure
  - Help calibrate microstructure evolution models used to predict neutron-irradiated microstructures
- ***In situ* ion irradiations allow real-time imaging of radiation damage and mechanistic insight**
- ***Ex situ* ion irradiations provide a larger damage volume and fine-tuning data for models to predict behavior in neutron environments**

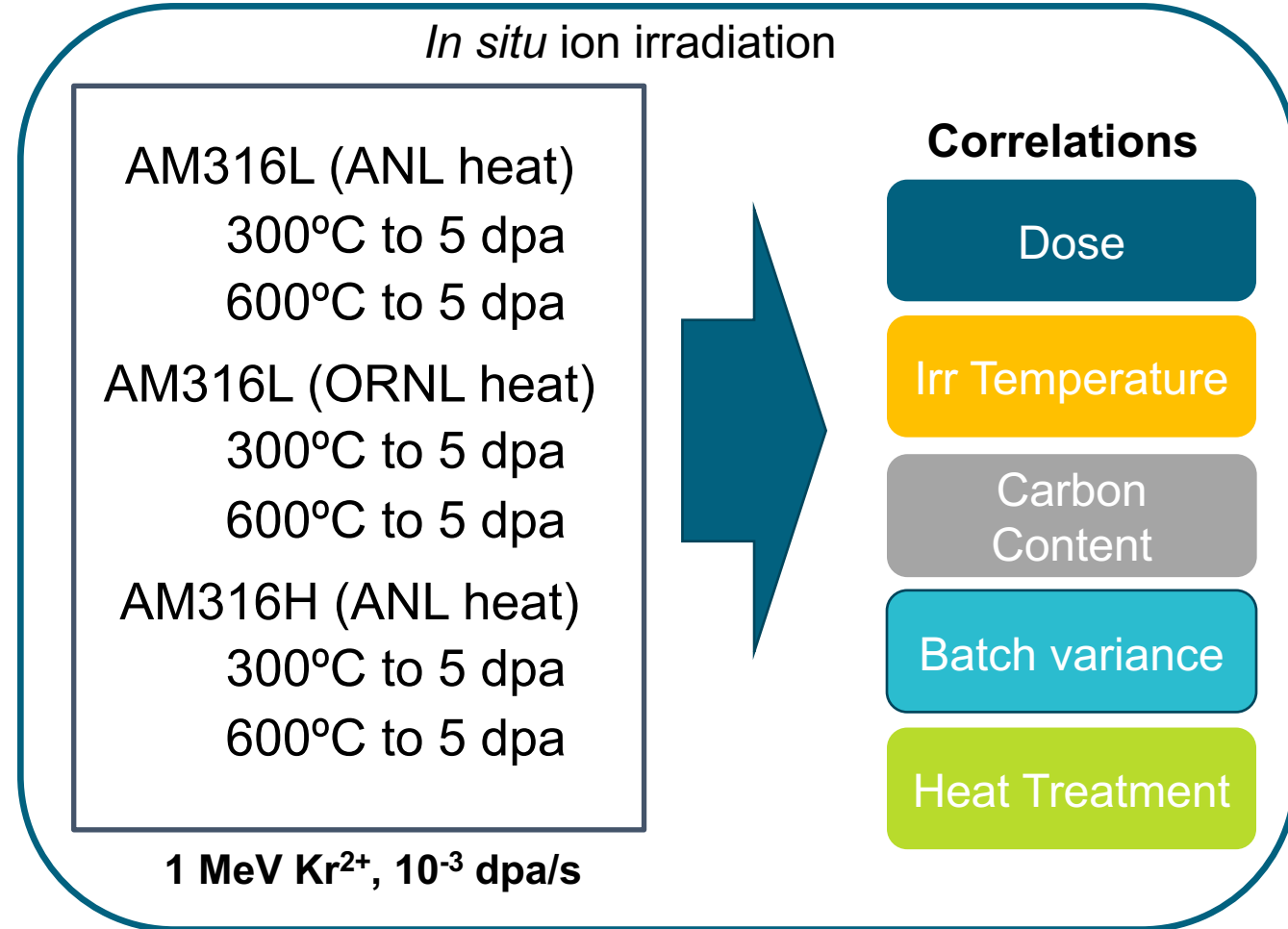

# Ion irradiation provides initial insights into microstructure evolution under irradiation for AM 316L and AM 316H

## • Compared three LPBF builds

- Similar starting microstructure (as-built)
- Dislocation cell size approximately 500 nm, walls approximately 50 – 100 nm wide
- Nanoscale oxide particles present
- Microsegregation of Cr, Si, Ni at at dislocation cell walls and HAGBs

Pre-irradiation characterization of as-printed material

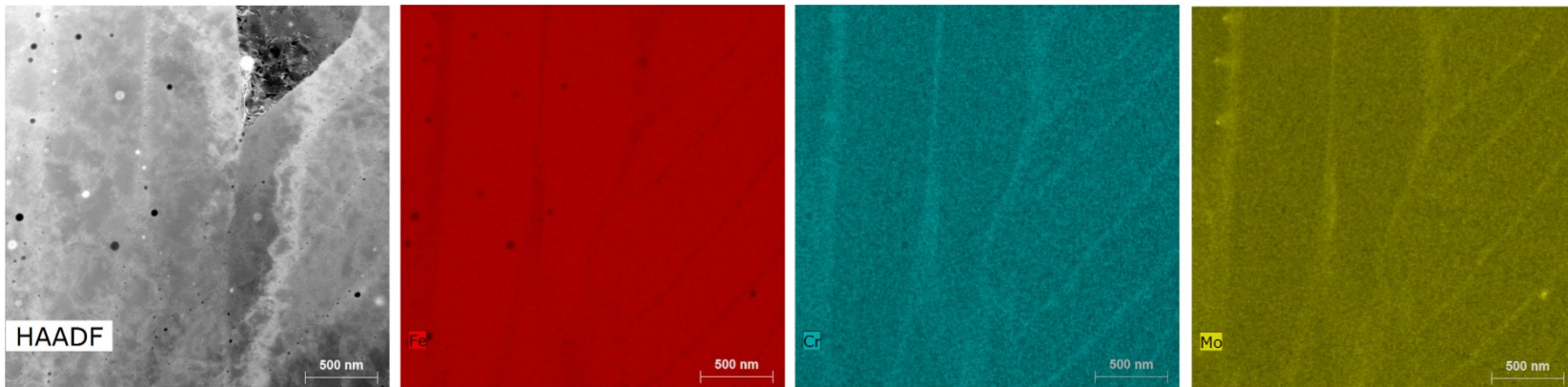
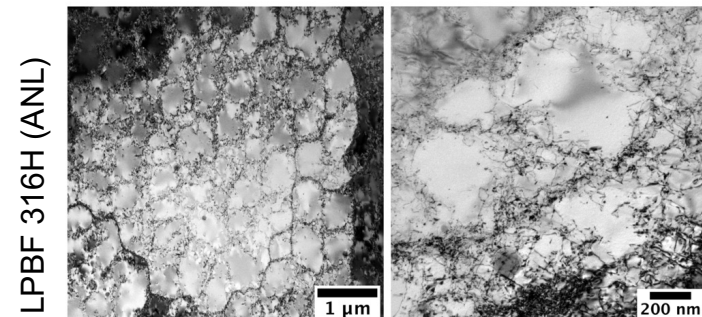
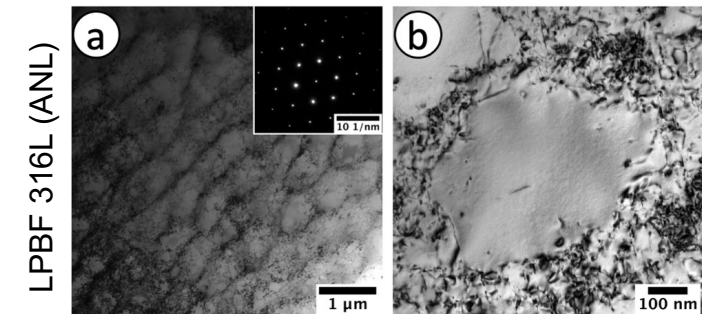
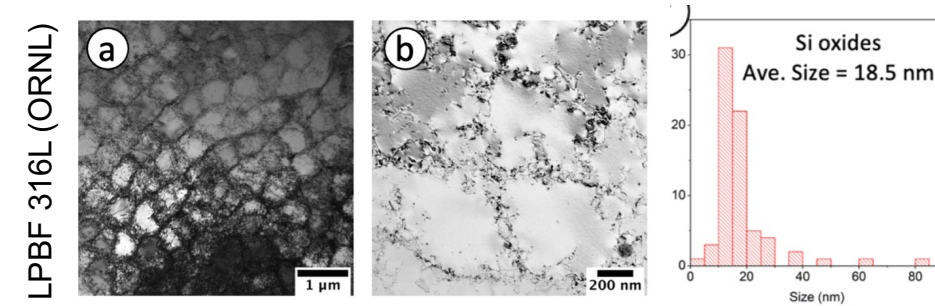

LPBF 316H (ANL)



# Irradiation temperature qualitatively impacts irradiation-driven microstructure evolution

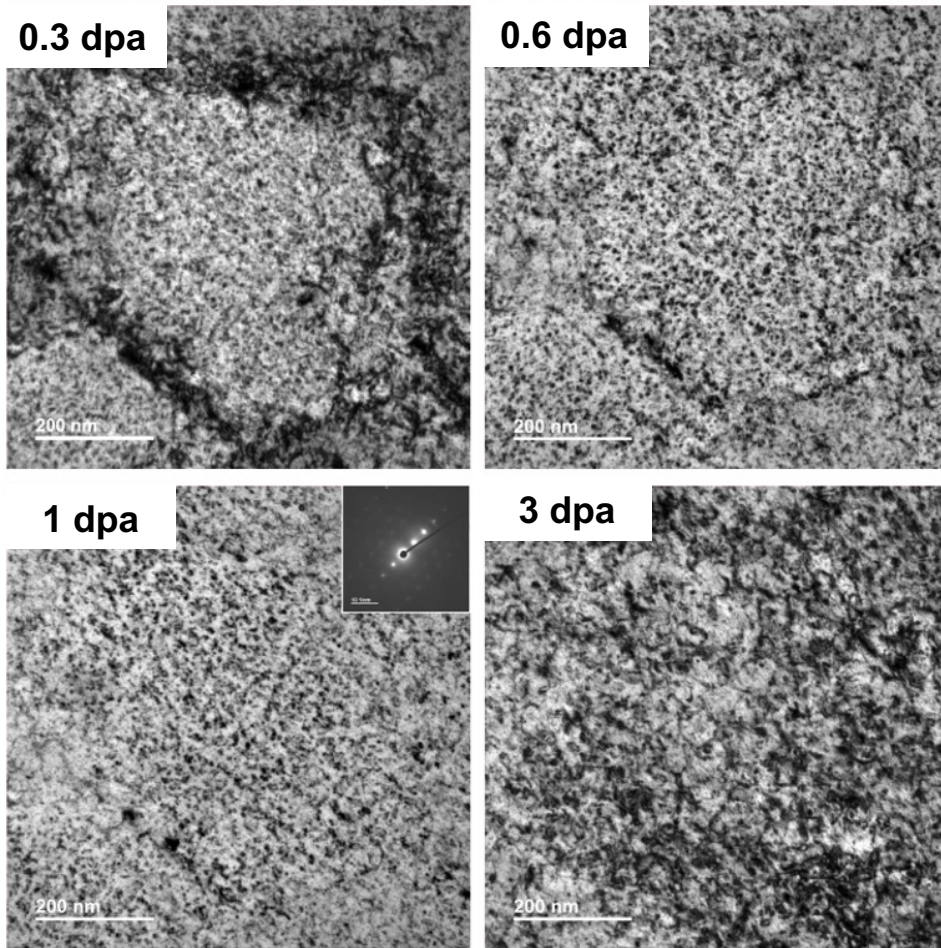

LPBF 316H irradiated at 300 °C

Loops: small, plentiful and uniform

$10^{-3}$  dpa/s  
1 MeV Kr<sup>+</sup>  
*In situ* irradiation

No voids observed in any in-situ irradiation

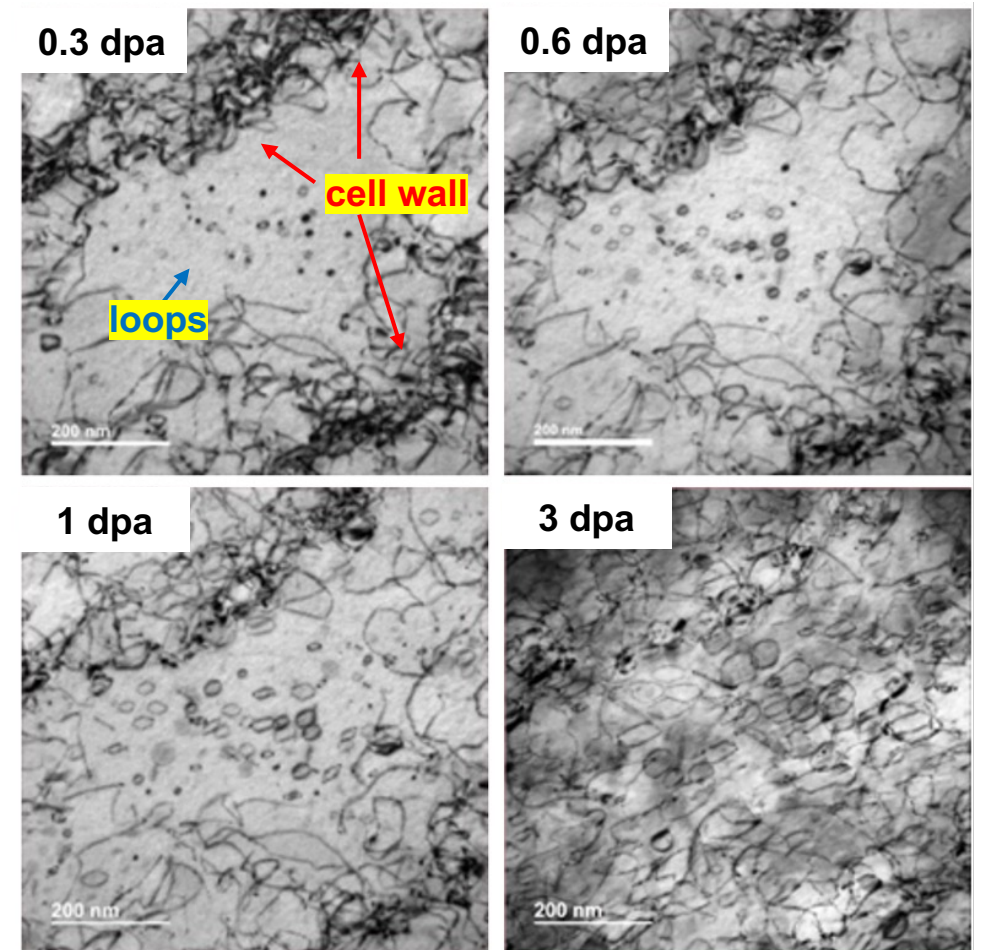

LPBF 316H irradiated at 600 °C

Loops: larger, fewer, nonuniform



# Carbon content appears to affect dislocation loop population evolution and stability

300°C, AM316L (1 dpa)

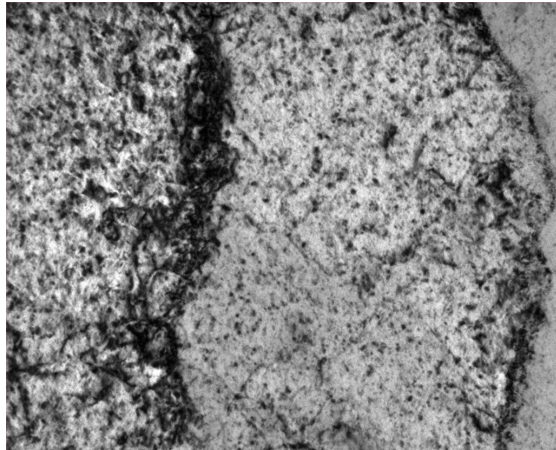

200 nm

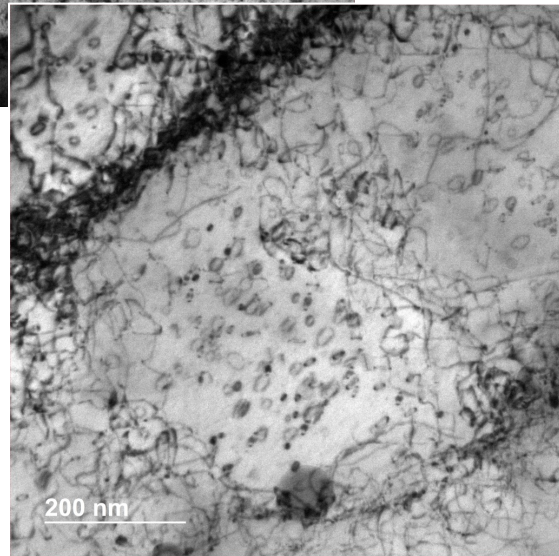

200 nm

ANL specimen

600°C, LPBF 316L (1 dpa)

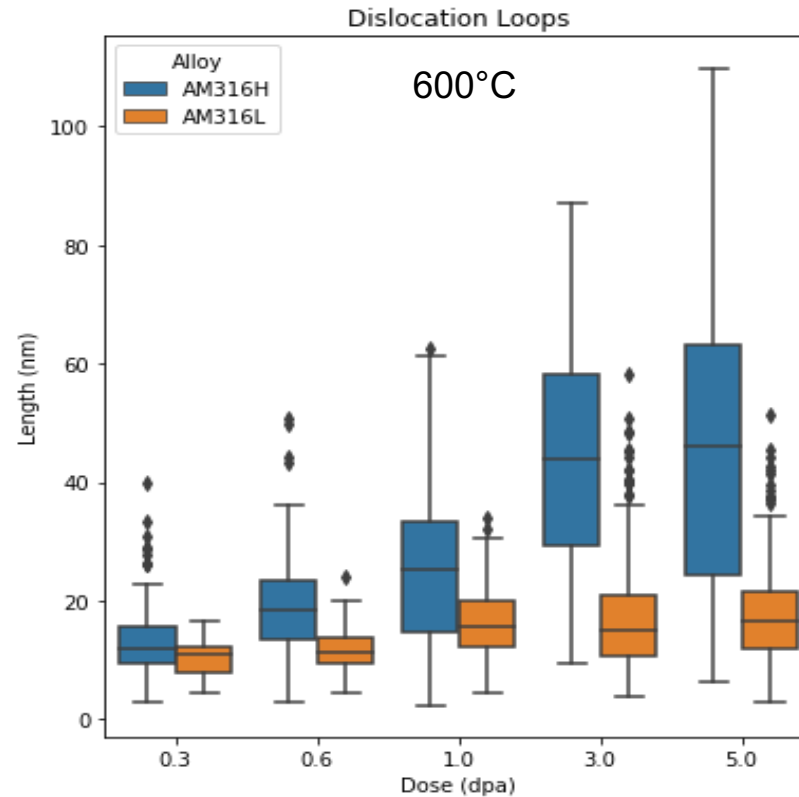

Qualitatively similar results at 300 °C and 600 °C for 316H and 316L, quantitative differences

Loop stability from 0.6 dpa to 1 dpa

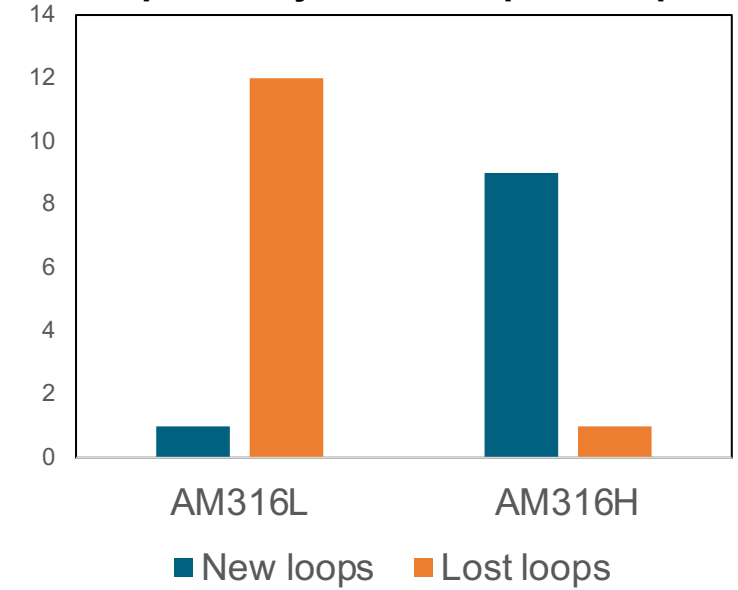

AM 316H, 600°C

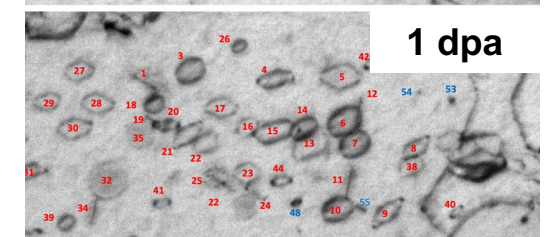
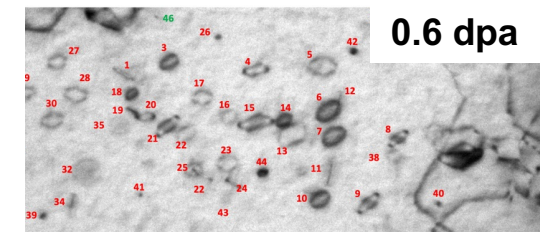







# Ex-situ ion irradiation and nanohardness testing reveals initial irradiation softening at 600 °C

- Ion irradiation of LPBF 316H at 600 °C and tested at room temperature
- Nanohardness testing reveals softening at 2 dpa and subsequent hardening through 10 dpa
- Hypothesize the softening is due to the recovery of the dislocation cell structure, formation of dislocation loops and and subsequent development of the uniform dislocation network

Irradiation Hardening in LPBF316H and LPBF 316L  
( $T_{\text{irr}} = 600^\circ \text{C}$ , 4 MeV Ni ion, dose rate =  $10^{-3}$  dpa/s)

Hardness measured at  $h_c = 200 \text{ nm}$   
Error bar = 2 x RSME

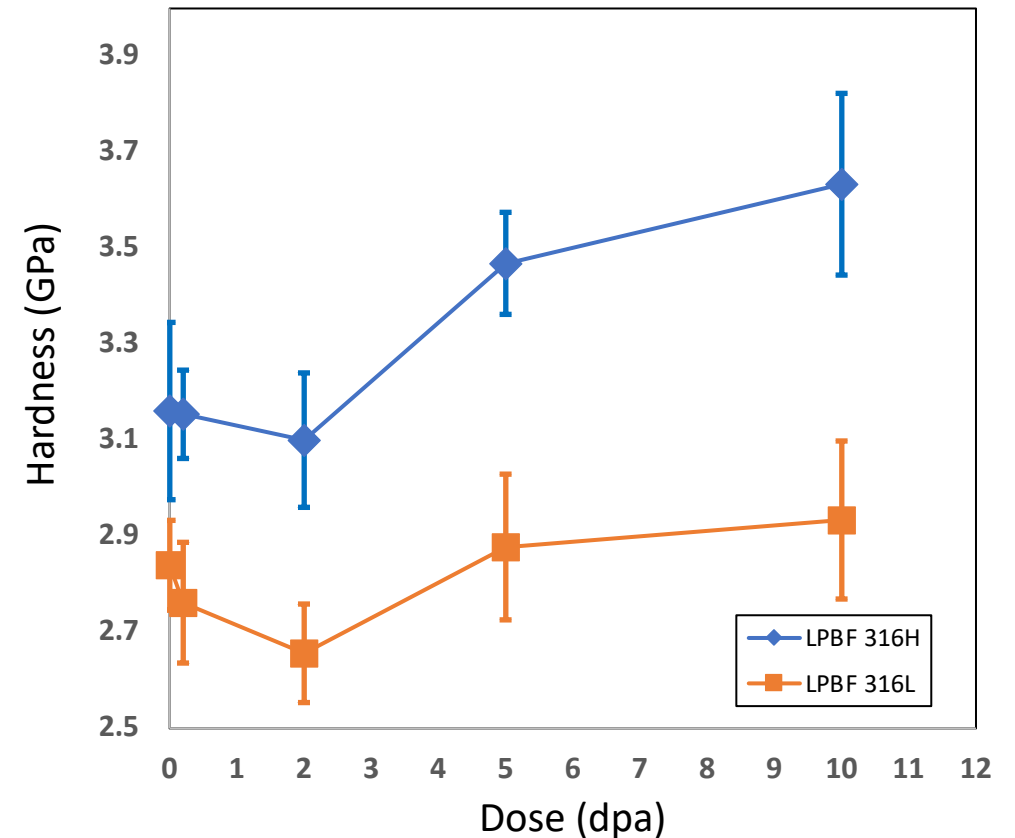



# Microstructure evolution comparison from neutron irradiation in HFIR

- **Actual neutron irradiation conditions:**
  - 250 °C, 277 °C , 376 °C, 600 °C, 673 °C (targets: 300 °C and 600 °C)
  - 0.2, 2, and 10 dpa
  - As-printed, heat treated, and wrought
- **Dislocation cell structure generally gone (need to determine if driven by thermal, radiation, or mixed effects)**
- **Features observed in all cases (population statistics vary depending on temperature and dose)**
  - Further characterization needed to determine if features are cavities or (Mn, Si) oxides

Summary of cavity(?) observations

	0.2 dpa	2 dpa	10 dpa
250 °C (AP)	Low density of a wide range of cavity sizes (AP)		
277 °C (AP, SA, WT)	High density of small cavities (SA)		High density of <5 nm cavities, some larger (AP, SA, WT)
376 °C (AP, SR, SA, WT)		Wide variety of cavity sizes (AP) / mostly large (SR) / Few cavities (WT)	
600 °C (AP, SR, SA)		Bimodal cavity size distribution (AP)	
673 °C (AP)	Only large cavities (AP)		

AP: As-printed      SR: Stress-relieved  
 SA: Solution-annealed      WT: Wrought

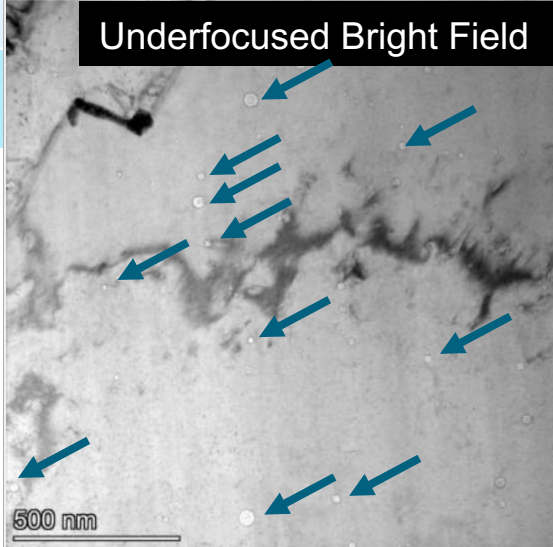

As-printed, 600 °C irradiation to 2 dpa

# Microstructure evolution comparison from neutron irradiation in HFIR

- **Actual neutron irradiation conditions:**

- 250 °C, 277 °C , 376 °C, 600 °C, 673 °C (targets: 300 °C and 600 °C)
- 0.2, 2, and 10 dpa
- As-printed, heat treated, and wrought

- **Dislocation cell structure generally gone (need to determine if driven by thermal, radiation, or mixed effects)**

- **Varied dislocation structure depending on dose and temperature, qualitatively more similar than by material condition**

## Summary of dislocation observations

	0.2 dpa	2 dpa	10 dpa
250 °C (AP)	High density of black spots (AP)		
277 °C (AP, SA, WT)			Large density of dislocation loops (AP, SA, WT)
376 °C (AP, SR, SA, WT)		Black spots and loops up to 100 nm (AP) / High density of loops up to 50 nm (SR, WT)	
600 °C (AP, SR, SA)		Black spots and network dislocations (AP) / few loops (SR)	
673 °C (AP)	Very little dislocation structure (AP)		

AP: As-printed      SR: Stress-relieved  
 SA: Solution-annealed      WT: Wrought

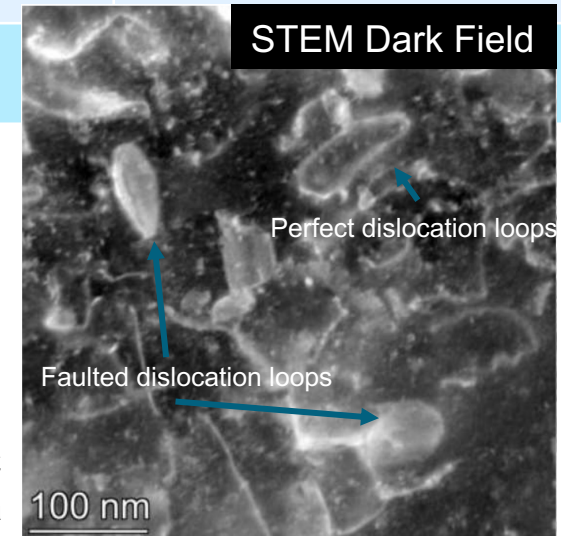

As-printed, 376 °C irradiation to 2 dpa

# Microstructure evolution comparison from neutron irradiation in HFIR

- **Actual neutron irradiation conditions:**
  - 250 °C, 277 °C , 376 °C, 600 °C, 673 °C (targets: 300 °C and 600 °C)
  - 0.2, 2, and 10 dpa
  - As-printed, heat treated, and wrought
- **Radiation-induced segregation is observed**
- **(Si, Mn)-oxide particles generally observed**
- **Cr-oxide and carbide particles not evident**
- **RIS may be more severe at lower temperatures**

Summary of segregation observations

	0.2 dpa	2 dpa	10 dpa
250 °C (AP)	Slight Si enhancement at HAGB (AP)		
277 °C (AP, SA, WT)			Ni, Si enhancement at GB and dislocations, Cr, Mo, Fe depletion (AP, SA)
376 °C (AP, SR, SA, WT)		Ni, Si enhancement at GB and dislocations, Cr, Mo, Fe depletion (AP, WT)	
600 °C (AP, SR, SA)		Ni, Si enhancement at GB and dislocations, Cr, Mo, Fe depletion (AP, SR)	
673 °C (AP)	Slight Ni enhancement/Gr depletion at HAGB (AP)		

AP: As-printed      SR: Stress-relieved  
SA: Solution-annealed      WT: Wrought

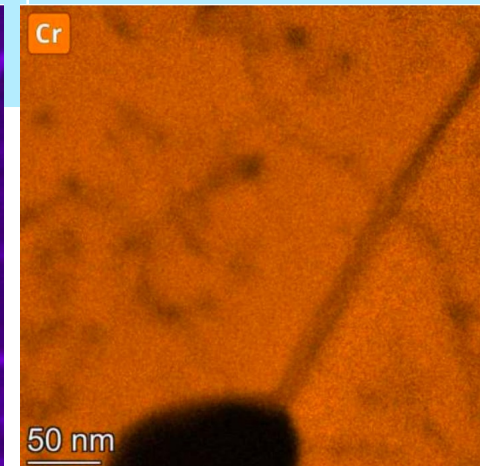
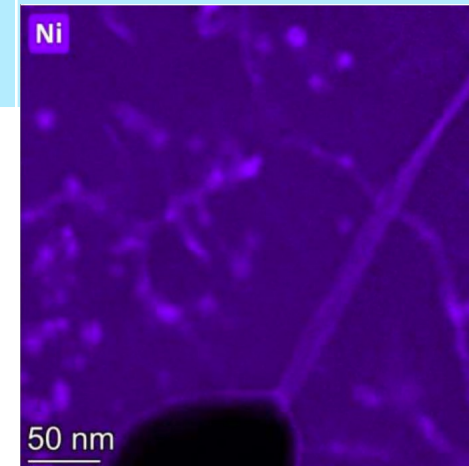

As-printed, 376 °C irradiation to 2 dpa



# Qualitative similarities between neutron and ion irradiated results provides strong basis for relating the two

- ***In situ* ion irradiation and neutron irradiation both observe:**
  - Similar development of dislocation loops → network dislocations
  - RIS to HAGB
  - (Si, Mn) oxide particles are stable
  - Carbide formation not observed
  - Softening at higher temperatures and low dpa
- **Differences in *in situ* ion irradiation vs neutron irradiation may be due to the characterization of 316L (neutron) vs 316H (ion)**
  - No cavities under ion irradiation; dual-beam irradiation is necessary and more work needed to determine nature of “cavity-like” features of neutron-irradiated material
  - Does not observe strong RIS to network dislocations or loops (weakly observed), but this may be due to the differences carbon content (316L vs 316H)
  - Observes Cr-oxide formation (may be due to differences in composition)
  - Observes dislocation cell walls remaining at higher dpa (may be due to better thermal stability in 316H)
- **Modeling and simulation effort will link results of the two irradiation campaigns**
- **White paper developed on the path forward for promoting the regulatory acceptance of combined ion and neutron irradiation data**



# Summary

- **AMMT program corrosion testing strategy on AM 316 prioritizes advanced reactor concerns**
- **Neutron irradiation campaigns are integrated at multiple DOE facilities to provide rapid insight into AM processing impacts on 316H**
- **Ion irradiation provides initial insights into microstructure evolution under irradiation for AM 316L and AM 316H and provide high quality data for model development**
- **AMMT is combining neutron irradiation, ion irradiation and modeling to progress a comprehensive framework for rapid qualification**

U.S. DEPARTMENT OF  
**ENERGY**

*Office of*  
**NUCLEAR ENERGY**