

June 27, 2023

TSTF-23-02  
PROJ0753

Attn: Document Control Desk  
U. S. Nuclear Regulatory Commission  
Washington, DC 20555-0001

SUBJECT: TSTF Response to NRC Request for Additional Information on TSTF-592, Revision 0, "Revise Automatic Depressurization System (ADS) Instrumentation Requirements"

On January 11, 2023, the NRC provided a Request for Additional Information (RAI) regarding TSTF-592, Revision 0, "Revise Automatic Depressurization System (ADS) Instrumentation Requirements," (Agencywide Documents Access and Management System Accession No. ML23010A259).

The TSTF's response to the NRC RAI is attached. The NRC provided clarifications to the questions on April 6, 2023. Those clarifications are addressed in the attachment.

The responses to the NRC's questions resulted in a revision to the traveler. Revision 1 of TSTF-592 is also enclosed.

Should you have any questions, please do not hesitate to contact us.



Andrew M. Richards, Jr. (PWROG/W)

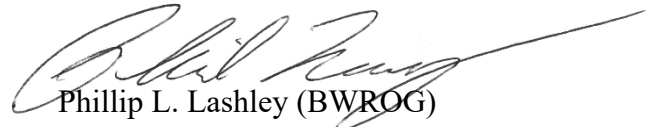

Phillip L. Lashley (BWROG)



Kevin Lueshen (PWROG/CE)

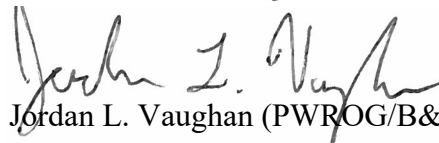

Jordan L. Vaughan (PWROG/B&W)

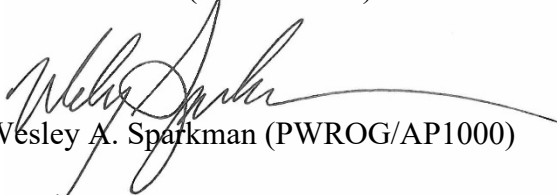

Wesley A. Sparkman (PWROG/AP1000)

Attachment  
Enclosure

cc: Michelle Honcharik, Technical Specifications Branch  
Victor Cusumano, Technical Specifications Branch

## **TSTF Response to NRC Questions on TSTF-592, Revision 0, "Revise Automatic Depressurization System (ADS) Instrumentation Requirements"**

The NRC request is repeated below in italics, followed by the TSTF response in unitalicized text. The NRC provided clarifications to the questions on April 6, 2023. Those clarifications are incorporated below.

*By letter dated July 19, 2022 (ADAMS Accession No. ML22200A080), the Technical Specifications Task Force (TSTF) submitted to the U.S. Nuclear Regulatory Commission (NRC) Traveler TSTF-592, Revision 0, "Revise Automatic Depressurization System (ADS) Instrumentation Requirements." TSTF-592 would revise Technical Specification (TS) 3.3.5.1, "Emergency Core Cooling System (ECCS) Instrumentation," Actions related to the Automatic Depressurization System (ADS) initiation instrumentation to correct several overly restrictive requirements, and to treat less significant channel inoperability's consistently. The proposed change modifies NUREG-1433, "Standard Technical Specifications - General Electric BWR/4 Plants," and NUREG-1434, "Standard Technical Specifications, General Electric BWR/6 Plants" (the STS).*

*The purpose of the ECCS instrumentation is to initiate appropriate responses from systems to ensure that the fuel is adequately cooled in the event of a design basis accident or transient.*

*The ECCS is designed to cool the reactor core following a loss of coolant accident (LOCA). The typical boiling water reactor (BWR) ECCS has low-pressure and high-pressure subsystems. The low pressure ECCS subsystems are designed to mitigate a large break LOCA where reactor vessel pressure rapidly decreases to the point at which the low-pressure ECCS pumps can inject water. There are two redundant divisions for each of the low-pressure ECCS subsystems. For example, BWR/4 plants typically have two Low Pressure Coolant Injection (LPCI) subsystems and two Core Spray (CS) subsystems. BWR/6 plants typically have one Low Pressure Core Spray (LPCS) subsystem and three LPCI subsystems. There is a single high-pressure ECCS subsystem. For example, BWR/4 plants have High Pressure Coolant Injection (HPCI), and BWR/6 plants have High Pressure Core Spray (HPCS). The high-pressure ECCS subsystem is designed to mitigate small break LOCAs during which reactor vessel pressure remains higher than the ability of the low-pressure ECCS pumps to inject water.*

*The ECCS instrumentation actuates in part, the Automatic Depressurization System (ADS). The ADS provides redundancy for the single high-pressure ECCS subsystem. In the event of failure of the high-pressure ECCS subsystem, the ADS valves open to rapidly reduce the reactor vessel pressure to the point at which a low-pressure ECCS pump can inject water.*

*To complete its review of TSTF-592, the NRC staff has determined that additional information is needed. The regulatory basis and the requested additional information are as follows.*

### *REGULATORY BASIS FOR REQUEST*

*10 CFR 50.36(a)(1) states in part: "A summary statement of the bases or reasons for such specification shall also be included in the application but shall not become part of the technical specifications."*

*10 CFR 50.36(c)(2) states: "Limiting conditions for operation are the lowest functional capability or performance levels of equipment required for safe operation of the facility. When a*

## **TSTF Response to NRC Questions on TSTF-592, Revision 0, "Revise Automatic Depressurization System (ADS) Instrumentation Requirements"**

*limiting condition for operation of a nuclear reactor is not met, the licensee shall shut down the reactor or follow any remedial action permitted by the technical specifications until the condition can be met."*

### *REQUESTS FOR ADDITIONAL INFORMATION*

- 1. TSTF-592 proposed to renumber BWR/4 and BWR/6 STS 3.3.5.1, "Emergency Core Cooling System (ECCS) Instrumentation," Condition H to Condition I. In the ECCS Instrumentation Bases B 3.3.5.1 markup, it appears that TSTF-592 did not change Condition H to Condition I in every instance. The NRC staff requests that TSTF-592 be reviewed and updated as appropriate. Applies to BWR/4 and BWR/6 STS Bases B 3.3.5.1.*

### Response

The TSTF concurs that the Required Action Bases for Conditions B, C, D, E, and F have a reference to Condition H that was not revised. This is corrected in the enclosed revision of the traveler.

- 2. {Revised by the April 6, 2023 e-mail.} TSTF-592 provided markups to the ECCS Instrumentation Bases B 3.3.5.1 for the ADS Functions associated with new Actions H.1, H.2, and H.3. Required Action H.1 is intended to ensure appropriate action when initiation capability is lost in both trip systems. The first paragraph in the BWR/6 ECCS Instrumentation Bases B 3.3.5.1 description for Actions H.1, H.2, and H.3 states, "Required Action H.1 is intended to ensure that appropriate actions are taken if one or more Functions 4.e and 4.f channels, and one or more Function 5.e channels are inoperable." However, it would take at least two and possibly three Function 5.e channels to be inoperable before Trip System B would lose initiation capability. The BWR/4 STS states, "Required Action H.1 is intended to ensure that appropriate actions are taken if a combination of Function 4.e, 4.f, 5.e, and 5.f channels are inoperable such that neither ADS Trip System A or B has two Operable Discharge Pressure - High channels associated with one low pressure ECCS pump." Given that the proposed remedial actions (i.e., Condition H and associated Required Actions and Completion Times) are nearly identical for BWR/4 and BWR/6, it appears that the wording from the BWR/4 STS Bases (modified for the appropriate BWR/6 ADS Function designators) is more appropriate for the BWR/6 STS Bases: "Required Action H.1 is intended to ensure that appropriate actions are taken if a combination of Function 4.e, 4.f, and 5.e channels are inoperable such that neither ADS Trip System A or B has two Operable Discharge Pressure-High channels associated with one low pressure ECCS pump." Therefore, based on the above, the NRC staff requests clarification on what specific conditions would require entering into Condition H and Required Action H.1. As part of the clarification, the NRC staff requests information that would explain why there is different wording in the first paragraph of the BWR/6 ECCS Instrumentation Bases B.3.3.5.1 for Actions H.1, H.2, and H.3 as compared to the BWR/4 ECCS Instrumentation Bases B 3.3.5.1 for Actions H.1, H.2, and H.3.*

## TSTF Response to NRC Questions on TSTF-592, Revision 0, "Revise Automatic Depressurization System (ADS) Instrumentation Requirements"

### Response

The wording of the NUREG-1434 Required Action H.1 Bases is revised in the enclosed traveler to be consistent with the proposed NUREG-1433 Required Action H.1 Bases.

- 3. TSTF-592 did not provide logic diagrams for ADS Trip System A and ADS Trip System B. The NRC staff believes that diagrams would facilitate understanding of the ADS Trip System logic described in TSTF-592. Therefore, the NRC staff requests that TSTF-592 include simplified logic diagrams for the ADS Trip System. The diagrams should depict relays, contacts, and any other devices necessary to achieve ADS actuation, as well as any descriptive information to help interpret the diagrams.*

### Response

Generic ADS logic diagrams for the BWR/4 and BWR/6 designs are included as figures in the enclosed revised traveler along with a disclaimer that the figures do not necessarily represent every plant. It was determined that there are variations in the ADS logic across the BWR/4 fleet. Descriptions of two of these variations were added to traveler. These variations do not affect the applicability of the change. The model application was revised to include an optional variation for licensees to describe the plant's ADS logic if it differs from the design described in the STS Bases.

- 4. The NRC position in NUREG-0737, Item II.K.3.18 states in part, "The automatic depressurization system (ADS) actuation logic should be modified to eliminate the need for manual actuation to assure adequate core cooling." In response, many licensees made modifications which would extend ADS operation to events which do not result in a release of steam to the drywell, but which may require depressurization of the reactor pressure vessel (RPV) to maintain adequate core cooling. Modifications included the addition of a timer that bypasses the existing high drywell pressure trip logic if RPV water level is low for a sustained period of time (hereafter, referred to as "bypass timer"). The current STS Actions related to channel inoperability for the high drywell pressure function and the bypass timer function are similar regarding completion times (e.g., up to 8 days). TSTF-592 does not propose any STS changes related to the high drywell pressure function, but it does propose changes to the bypass timer, which bypasses the high drywell pressure trip logic. From a logic perspective, inoperability of the bypass timer has the same effect as inoperability of the high drywell pressure. The inoperability of one bypass timer channel will prevent one of the ADS trip systems from automatic initiation capability unless there is a concurrent high drywell pressure signal. Likewise, the inoperability of a high drywell pressure channel will prevent one of the ADS trip systems from automatic initiation capability, unless there is a concurrent bypass timer signal. Bypass timer channel inoperability in both trip systems will prevent ADS automatic initiation capability unless there are concurrent high drywell pressure signals. Likewise, high drywell pressure channel inoperability in both trip systems will prevent ADS automatic initiation capability, unless there are concurrent bypass timer signals. TSTF-592 proposed to change the completion time for situations where bypass timer(s) is(are) inoperable from up to 8 days to 30 days (i.e., ADS Low Level Actuation Timer in BWR/4 (Function 4g and 5g) and ADS Bypass Timer*

## **TSTF Response to NRC Questions on TSTF-592, Revision 0, "Revise Automatic Depressurization System (ADS) Instrumentation Requirements"**

*High Drywell Pressure in BWR/6 (Function 4g and 5f). STS Table 3.3.5-1, "Emergency Core Cooling Instrumentation," specifies an Allowable Value for the bypass timer where according to the STS Bases, the Allowable Value serves as the limiting safety system setting (LSSS). Technical Specifications are required by 10 CFR 50.36 to include LSSSs for variables that have significant safety system functions. LSSS are defined by regulation (50.36) as "Where a LSSS is specified for a variable on which a safety limit has been placed, the setting must be chosen so that automatic protective actions will correct the abnormal situation before a safety limit is exceeded." The NRC staff considers that different treatment (i.e., completion times) in the STS for the bypass timer function as compared to the high drywell pressure function may not be responsive to the NRC position expressed in NUREG-0737 and the current STS, because ADS is part of the primary success path for automatic mitigation of a design basis accident. Based on the discussion above, the NRC staff requests that the TSTF 1) provide additional information that justifies why the proposed changes to the Actions for the "bypass timer" are appropriate or 2) return the "bypass timer" Actions to those found in the current STS (or equivalent to those in the current STS). Applies to STS for BWR/4 and BWR/6.*

### Response

The bypass timer functions were assigned to Condition H because they are not credited in the accident analysis; e.g., the bypass timer functions allow ADS to function automatically for steam line breaks outside of Primary Containment as a diverse means to maintain RPV level. With a timer function inoperable, manual ADS actuation would still be possible. However, on further consideration, because the manual initiation functions were assigned to Condition H, it is possible for both bypass timer functions and the manual initiation functions to be inoperable, resulting in an inability to initiate ADS. A 30-day Completion Time is inappropriate for this condition, and in the revised attached traveler the bypass timer functions are now assigned to Condition G.

- 5. TSTF-592 provided markups to ECCS Instrumentation Bases B 3.3.5.1 related to Actions G.1 and G.2. However, the markup did not include a discussion regarding what Required Action G.2 is intended to ensure. For example, proposed Bases language for Required Action H.2 states, "Required Action H.2 is intended to ensure that appropriate actions are taken if [...], which results in automatic initiation capability being lost for that ADS trip system." The NRC staff requests that TSTF-592 includes a discussion in ECCS Instrumentation Bases B 3.3.5.1, Actions G.1 and G.2, that describes what Required Action G.2 is intended to ensure. Applies to STS BWR/4 and BWR/6.*

### Response

The proposed Bases describe the purpose of Required Action G.2. The last paragraph of the Bases for Required Actions G.1 and G.2 states (emphasis added):

Because of the diversity of sensors available to provide initiation signals and the redundancy of the ECCS design, an allowable out of service time of 8 days has been shown to be acceptable (Ref. 6) to permit restoration of any inoperable channel to OPERABLE status if

## TSTF Response to NRC Questions on TSTF-592, Revision 0, "Revise Automatic Depressurization System (ADS) Instrumentation Requirements"

both HPCI and RCIC are OPERABLE (**Required Action G.2**). [Alternatively, a Completion Time can be determined in accordance with the Risk Informed Completion Time Program.] If either HPCI or RCIC is inoperable, the time shortens to 96 hours [or in accordance with the Risk Informed Completion Time Program]. If the status of HPCI or RCIC changes such that the Completion Time changes from 8 days to 96 hours, the 96 hours begins upon discovery of HPCI or RCIC inoperability. However, the total time for an inoperable channel cannot exceed 8 days. If the status of HPCI or RCIC changes such that the Completion Time changes from 96 hours to 8 days, the "time zero" for beginning the 8 day "clock" begins upon discovery of the inoperable channel. If the inoperable channel cannot be restored to OPERABLE status within the allowable out of service time, Condition I must be entered and its Required Action taken. The Required Actions do not allow placing the channel in trip since this action would not necessarily result in a safe state for the channel in all events.

Therefore, the Bases are not revised.

6. *TSTF-592 provided markups to ECCS Instrumentation Bases B 3.3.5.1 related to new Actions H.1, H.2, and H.3. While describing Required Action H.1, TSTF-592 states in part, "In this situation (loss of automatic initiation capability), the 96 hour or 8-day allowance, as applicable, of Required Action H.2 is not appropriate, and all ADS valves must be declared inoperable within 1 hour after discovery of loss of ADS initiation capability" (emphasis added). The Bases description for Required Action G.1 has a similar statement but clarifies the loss of ADS initiation capability by adding the following expression after capability: "in both trip systems." Therefore, the NRC staff requests information that explains why ECCS Instrumentation Bases B 3.3.5.1, Actions H.1, H.2 and H.3 description did not include the expression "in both trip systems," after "capability." Applies to STS BWR/4 (BWR/6 Bases included this expression).*

### Response

The phrase "in both trip systems" is added to second paragraph of the Bases for Required Action H.1, H.2, and H.3 in NUREG-1433 and NUREG-1434 in the enclosed revised traveler.

7. *TSTF-592 provided markups to ECCS Instrumentation Bases B 3.3.5.1 related to new Actions H.1, H.2 and H.3. In the BWR/6 markup for that Bases section, the third paragraph begins with "The Completion Time ..." and ends with "... time for restoration or tripping of channels" (emphasis added). The BWR/4 markup for new Actions H.1, H.2, H.3 did not include the expression "or tripping." It's not clear to the NRC staff why there is a difference between the BWR/4 STS and BWR/6 STS regarding the expression "or tripping." Therefore, the NRC staff requests information that explains the different treatment of ECCS Instrumentation Bases B.3.3.5.1 for Actions H.1, H.2, and H.3 regarding the expression "or tripping."*

## TSTF Response to NRC Questions on TSTF-592, Revision 0, "Revise Automatic Depressurization System (ADS) Instrumentation Requirements"

### Response

The last sentence of the NUREG-1433 Bases for Required Actions H.1, H.2, and H.3 is revised in the enclosed traveler to state, "...while allowing time for restoration or tripping of channels."

It was also noted that in the existing Bases for Required Actions G.1 and G.2 in NUREG-1433 and NUREG-1434, the third paragraphs describe "restoration or tripping of channels." "Tripping" of channels is not a Required Action under Condition G. Therefore, the Bases text is revised to state "restoration of channels." Section 2.4 of the traveler justification was revised to discuss this change.

8. *TSTF-592 proposed to change the Completion Time from "up to 8 days" to "30 days" for several ADS Trip System Functions (see remedial actions associated with proposed Condition H). Based on the NRC staff's review of TSTF-592 STS Bases markups, the NRC staff did not identify a clear discussion in the STS Bases that justifies continued operation at the reduced state from the state specified in the LCO for the proposed Completion Time of 30 days. Therefore, the NRC staff requests information be provided in the STS Bases that explains why 30 days is an appropriate Completion Time.*

### Response

The following justification is added to the Bases description of Required Action H.3 in the enclosed revised traveler:

The 30 day Completion Time of Required Action H.3 is acceptable, based on operating experience, considering the multiple channels available for meeting the low pressure ECCS discharge pressure permissive, and the availability of automatic ADS initiation.

9. *TSTF-592 proposed Condition H is associated with three Required Actions: H.1, H.2, and H.3. According to the ECCS Instrumentation Bases B 3.3.5.1 markup, "Required Action H.3 is intended to ensure that appropriate actions are taken if inoperable channels within one ADS trip system do not result in loss of automatic initiation capability to respond to a design basis event but require restoration per Table 3.3.5.1-1" (emphasis added). It appears that the intended purpose of H.3 as stated above may not be appropriate for all associated Functions. For example, there are ADS Functions subject to Condition H and Required Action H.3, where it appears that inoperable channels within one ADS Trip System would result in loss of automatic initiation capability to respond to a design basis event. In the BWR/4 STS, proposed Required Action H.3 applies to Functions 4.e, 4.f, 4.g, 4.h, 5.e, 5.f, 5.g, and 5.h. Similarly, in the BWR/6 STS, proposed Required Action H.3 applies to Functions 4.e, 4.f, 4.g, 4.h, 5.e, 5.f, and 5.g. For the sake of this discussion BWR/4 Functions 4.g and 5.g, and BWR/6 Functions 4.g and 5.f, are referred to as "bypass timers." Required Action H.1 and H.2 are only applicable to Functions 4.e, 4.f, 5.e, and 5.f (BWR/4) and 4.e, 4.f, and 5.e (BWR/6). As a result, Required Action H.3 is the only Required Action that applies to the "bypass timers." From the ADS logic as described in TSTF-592, one inoperable "bypass timer" channel will prevent one of the ADS trip systems to initiate and would result in loss of automatic initiation capability to respond to a design basis event (e.g., events which do not*

## **TSTF Response to NRC Questions on TSTF-592, Revision 0, "Revise Automatic Depressurization System (ADS) Instrumentation Requirements"**

*result in a release of steam to the drywell but which may require depressurization of the reactor pressure vessel (RPV) to maintain adequate core cooling) and therefore would not meet the intended purpose for Required Action H.3 as described in the STS Bases. In addition, an inoperable "bypass timer" channel in both ADS Trip Systems will prevent ADS actuation. Therefore, it's unclear to the staff how the ADS "bypass timer" Function can be subject to Required Action H.3 based on not meeting the intended purpose of Required Action H.3 (i.e., an inoperable "bypass timer" channel within one ADS Trip System would result in loss of automatic initiation capability to respond to a design basis event). Based on the above, the NRC staff requests information that justifies why it is appropriate to associate an inoperable ADS "bypass timer" channel with the remedial actions provided by Condition H and Required Action H.3.*

### Response

Please refer to the response to RAI 4, which describes changes to the attached traveler to address this issue.

*10. For the ADS low pressure ECCS pump discharge pressure switch (PS) instrument to perform its ADS Trip System Function (pump discharge pressure high), it relies on the pump itself to be OPERABLE and in operation. For example, based on TSTF-592 markups for BWR/6, if one of the PSs from the LPCI Pump A is inoperable, Condition H is entered, and the 30-day Completion Time clock starts for Required Action H.3. Required Action H.2 Completion Time clock does not start because the LPCS Pump has both of its PSs OPERABLE. Subsequently, if the LPCS pump is declared inoperable, its pressure switches would not be available and ADS Trip System A will not initiate ADS on a valid signal even if LPCI Pump A starts. The NRC staff requests information that explains how this situation would be addressed. As part of the response, address whether credit should be given for the pressure switches associated with an inoperable low-pressure injection/spray pump.*

### Response

Declaring a low pressure ECCS pump inoperable does not necessarily render the associated ADS discharge pressure permissive function inoperable. That would be assessed separately under a site's Corrective Action Program and Operability Determination process. However, accepting the RAIs premise on pump Operability, Required Action H.3 is applicable to the LPCI Pump A pressure switch, while both Required Actions H.2 and H.3 are applicable to the LPCS pump pressure switches. Note that in response to RAI 11, the wording of Required Action H.3 is being revised.

*11. The current BWR/4 and BWR/6 STS 3.3.5.1 for the ADS Trip System Function has a remedial action for when a low pressure ECCS pump discharge pressure high channel is inoperable that states, "Restore channel to OPERABLE status" (see current Required Action G.2). TSTF-592 proposed a new remedial action (see Required Action H.3) for when a low pressure ECCS pump discharge pressure high channel is inoperable that states, "Restore all channels to OPERABLE status" (emphasis added). The NRC staff requests information that*

## **TSTF Response to NRC Questions on TSTF-592, Revision 0, "Revise Automatic Depressurization System (ADS) Instrumentation Requirements"**

*provides the basis for changing remedial action wording from "... channel ..." to "... all channels ...".*

### Response

Required Action H.3 is revised to read "Restore channel to OPERABLE status" in the enclosed traveler.

*12. TSTF-592 proposed Condition H is associated with three Required Actions: H.1, H.2, and H.3. From the proposed change to the TS Bases, Action H.2 is required when a trip system does not have at least one low-pressure injection/spray pump with both Discharge Pressure High channels OPERABLE. Therefore, Action H.2 is only required if there are multiple pressure switches inoperable in a Trip System. As such, the Completion Times for H.2 would necessarily have a modified time zero. The 96-hour completion time would only start when a switch becomes inoperable, concurrent with other inoperable switches, that results in no pumps in that trip system having two OPERABLE Discharge Pressure High channels concurrent with HPCI or RCIC inoperability. Likewise, the 8-day Completion Time would only start when a switch becomes inoperable, concurrent with other inoperable switches, that results in no pumps in that trip system having two OPERABLE Discharge Pressure High channels. The proposed wording for the 96-hour Completion Time has "inoperable channel" when it actually starts when multiple channels become inoperable such that no low-pressure pump in a Trip System has both pressure switches operable concurrent with HPCI or RCIC inoperability. The proposed wording for the 8-day Completion Time implies that it would start when Action H.2 is required, which again requires multiple, inoperable pressure switches. Based on the discussion above, the NRC staff requests clarification on the conditions required to start the 96 hour and 8-day completion times of Action H.2.*

### Response

It is accurate that multiple channels must be inoperable in order for Required Action H.2 to apply. Therefore, the Required Action H.2 Completion Time is changed in the enclosed traveler to make the word "channel" plural. Additionally, it was noted that the 96 hour and 8 day Completion Times should both contain a modified "time zero" associated with the discovery of a loss of ADS initiation capability in one trip system for consistency with STS Section 1.3. These changes have been incorporated in the traveler.

**Enclosure**

**TSTF-592, Revision 1, "Revise Automatic Depressurization System  
(ADS) Instrumentation Requirements"**

---

## Technical Specifications Task Force Improved Standard Technical Specifications Change Traveler

---

### Revise Automatic Depressurization System (ADS) Instrumentation Requirements

NUREGs Affected:  1430  1431  1432  1433  1434  2194

---

Classification: 1) Technical Change

Recommended for CLIP?: Yes

Correction or Improvement: Improvement

NRC Fee Status: Not Exempt

Benefit: Avoids a Plant Shutdown

Changes Marked on ISTS Rev 5.0

PWROG RISD & PA (if applicable): None

---

See attached.

---

### Revision History

#### OG Revision 0

**Revision Status: Closed**

---

Revision Proposed by: BWROG

Revision Description:  
Original Issue

---

#### Owners Group Review Information

Date Originated by OG: 10-Mar-22

Owners Group Comments

Original draft distributed on 1/20/2022. BWROG comments resulted in significant revision to the traveler. Redistributed for BWROG review.

Owners Group Resolution: Approved Date: 28-Mar-22

---

#### TSTF Review Information

TSTF Received Date: 28-Jun-22

Date Distributed for Review 28-Jun-22

TSTF Comments:

(No Comments)

TSTF Resolution: Approved

Date: 19-Jul-22

---

#### NRC Review Information

NRC Received Date: 19-Jul-22

NRC Comments:

NRC had only editorial comments on the draft. At the presubmittal meeting, NRC requested that submitted traveler discuss the origin of the current Actions and that information was incorporated.

The NRC provided draft comments on December 12, 2022.

---

27-Jun-23

**TSTF Revision 1****Revision Status: Active**

Revision Proposed by: BWROG

Revision Description:

Revised to address NRC RAI.

- 1) Corrected additional Condition H references in the Bases to renumbered Condition I.
- 2) Revised the NUREG-1434 Condition H Bases to be consistent with the NUREG-1433 Condition H Bases.
- 3) Added example ADS logic diagrams as an attachment to the traveler.
- 4) Reassigned the bypass timer functions (NUREG-1433 Functions 4.g and 5.g, NUREG-1434 Functions 4.g and 5.f) from Condition H to Condition G.
- 5) Made other recommended Bases improvements.
- 6) Revised the model application to require licensees to describe the ADS initiation logic if it differs from the design described in the STS.

Revised to address NRC comments on the draft traveler.

Revised NUREG-1433 3.3.5.1 Actions and NUREG-1434 3.8.1 Action to correctly present a modified "Time Zero" Completion Time with the option to apply a Risk Informed Completion Time.

**Owners Group Review Information**

Date Originated by OG: 03-May-23

Owners Group Comments  
(No Comments)

Owners Group Resolution: Approved Date: 18-May-23

**TSTF Review Information**

TSTF Received Date: 19-May-23

Date Distributed for Review 19-May-23

TSTF Comments:  
(No Comments)

TSTF Resolution: Approved

Date: 26-Jun-23

**NRC Review Information**

NRC Received Date: 27-Jun-23

NRC Comments:

NRC provided comments on the draft RAI response and traveler on April 6, 2023.

**Affected Technical Specifications**

LCO 3.3.5.1 ECCS Instrumentation

Change Description: Table 3.3.5.1-1

Action 3.3.5.1.B Bases ECCS Instrumentation

Action 3.3.5.1.C Bases ECCS Instrumentation

27-Jun-23

|                        |                        |                           |
|------------------------|------------------------|---------------------------|
| Action 3.3.5.1.D Bases | ECCS Instrumentation   |                           |
| Action 3.3.5.1.E Bases | ECCS Instrumentation   |                           |
| Action 3.3.5.1.F Bases | ECCS Instrumentation   |                           |
| Action 3.3.5.1.G       | ECCS Instrumentation   |                           |
| Action 3.3.5.1.G Bases | ECCS Instrumentation   |                           |
| Action 3.3.5.1.H       | ECCS Instrumentation   |                           |
|                        | Change Description:    | New Action                |
| Action 3.3.5.1.H Bases | ECCS Instrumentation   |                           |
|                        | Change Description:    | New Action                |
| Action 3.3.5.1.I       | ECCS Instrumentation   |                           |
|                        | Change Description:    | Action H renamed Action I |
| Action 3.3.5.1.I Bases | ECCS Instrumentation   |                           |
|                        | Change Description:    | Action H renamed Action I |
| Action 3.3.5.1.F       | ECCS Instrumentation   | NUREG(s)- 1433 Only       |
| Action 3.8.1           | AC Sources - Operating | NUREG(s)- 1434 Only       |

## 1. SUMMARY DESCRIPTION

The proposed change revises the Technical Specification (TS) 3.3.5.1, "Emergency Core Cooling System (ECCS) Instrumentation," Actions related to the Automatic Depressurization System (ADS) initiation instrumentation to correct several overly restrictive requirements, and to treat less significant channel inoperabilities consistently. The proposed change modifies NUREG-1433, "Standard Technical Specifications - General Electric BWR/4 Plants," and NUREG-1434, "Standard Technical Specifications, General Electric BWR/6 Plants" (the STS).<sup>1</sup>

## 2. DETAILED DESCRIPTION

### 2.1. System Descriptions

The ECCS is designed to cool the reactor core following a loss of coolant accident (LOCA). The typical BWR ECCS has low-pressure and high-pressure subsystems. The low pressure ECCS subsystems are designed to mitigate a large break LOCA where reactor vessel pressure rapidly decreases to the point at which the low-pressure ECCS pumps can inject water. There are two redundant divisions for each of the low-pressure ECCS subsystems. For example, BWR/4 plants typically have two Low Pressure Coolant Injection (LPCI) subsystems and two Core Spray (CS) subsystems. BWR/6 plants typically have one Low Pressure Core Spray (LPCS) subsystem and three Low Pressure Coolant Injection subsystems.

There is a single high-pressure ECCS subsystem. For example, BWR/4 plants have High Pressure Coolant Injection (HPCI), and BWR/6 plants have High Pressure Core Spray (HPCS). The high-pressure ECCS subsystem is designed to mitigate small break LOCAs during which reactor vessel pressure remains higher than the ability of the low-pressure ECCS pumps to inject water.

The ADS provides redundancy for the single high-pressure ECCS subsystem. In the event of a failure of the high-pressure ECCS subsystem, the ADS valves open to release reactor vessel pressure to the suppression pool, rapidly reducing the pressure to the point at which a low-pressure ECCS subsystem can inject water.

The ADS valves will not open unless at least one low-pressure ECCS pump is operating to provide a source of coolant once the reactor vessel has been depressurized. Any one of the six BWR/4 low pressure pumps or four BWR/6 low pressure pumps is sufficient to permit automatic depressurization. The ADS instrumentation monitors reactor vessel water level and drywell pressure to initiate ADS. These parameters may indicate a failure of the high-pressure ECCS subsystem if reactor vessel water level does not recover following ECCS initiation.

---

<sup>1</sup> NUREG-1433 is based on the boiling water reactor (BWR)/4 plant design, but is also representative of the BWR/2, BWR/3, and, in some cases, BWR/5 designs. NUREG-1434 is based on the BWR/6 plant design, and is representative in some cases of the BWR/5 design.

ADS timers provide sufficient time for a high-pressure ECCS subsystem to recover reactor vessel water level before opening the ADS valves. There are two ADS initiation timers, one in each of the two ADS trip systems.

There are two ADS trip systems, designated as ADS Trip Systems A and B, with one trip system associated with each division of the low-pressure ECCS subsystems. Either trip system can open all the ADS valves if drywell pressure and reactor vessel water level conditions are satisfied, the ADS initiation timer has completed, and one low-pressure ECCS pump associated with the trip system is operating as indicated by pump discharge pressure.

The NUREG-1433 and NUREG-1434 Bases describe the ECCS low pressure pump discharge pressure permissives input to the ADS logic for the reference plant designs. Two channels of discharge pressure monitoring instrumentation are associated with each low-pressure ECCS pump, and both of a pump's associated channels must actuate to satisfy the ADS trip system logic that indicates pump operation. The BWR/4 Core Spray pump A and LPCI Pumps A and D, and the BWR/6 LPCS pump and LPCI Pump A channels input to the ADS Trip System A logic. The BWR/4 Core Spray Pump B and LPCI pumps B and C, and the BWR/6 LPCI Pumps B and C channels input to the ADS Trip System B logic. Only a single low pressure ECCS pump with two operable channels is required for the associated ADS Trip System to respond to design basis events. Generic logic diagrams for the BWR/4 and BWR/6 ADS low pressure permissive logic are provided in Attachments 1 and 2. Note – These logic diagrams do not necessarily fully represent the ADS logic of the STS reference plant.

One of the signals required for ADS initiation is Drywell Pressure - High. However, if an event requiring ADS initiation occurs outside the drywell (e.g., main steam line break outside containment), a Drywell Pressure - High signal may not be present. In the BWR/4 design, the Automatic Depressurization System Low Water Level Actuation Timer is used to bypass the Drywell Pressure - High Function after a certain time period has elapsed. In the BWR/6 design, the ADS Bypass Timer (High Drywell Pressure) Function is used for the same purpose. There are four of these timers, two in each of the two ADS trip systems. Neither function is assumed in any accident analysis.

There are also ADS manual initiation push buttons which are not credited in any accident analysis.

## **2.2. Current Technical Specifications Requirements**

BWR/4 (NUREG 1433), TS 3.3.5.1, "Emergency Core Cooling System (ECCS) Instrumentation," Table 3.3.5.1-1 provides the requirements for ADS Trip Systems A and B. The following functions reference Action G:

4. ADS Trip System A
  - c. ADS Initiation Timer
  - e. Core Spray Pump Discharge Pressure – High
  - f. Low Pressure Coolant Injection Pump Pressure – High
  - g. ADS Low Water Level Actuation Timer
  - h. Manual Actuation

5. ADS Trip System B
  - c. ADS Initiation Timer
  - e. Core Spray Pump Discharge Pressure – High
  - f. Low Pressure Coolant Injection Pump Discharge Pressure – High
  - g. ADS Low Water Level Actuation Timer
  - h. Manual Actuation

BWR/6 (NUREG 1434), TS 3.3.5.1, "Emergency Core Cooling System (ECCS) Instrumentation," Table 3.3.5.1-1 provides the requirements for ADS Trip Systems A and B. The following functions reference Action G:

4. ADS Trip System A
  - c. ADS Initiation Timer
  - e. LPCS Pump Discharge Pressure – High
  - f. LPCI Pump A Discharge Pressure – High
  - g. ADS Bypass Timer (High Drywell Pressure)
  - h. Manual Actuation
  
5. ADS Trip System B
  - c. ADS Initiation Timer
  - e. LPCI Pumps B & C Discharge Pressure – High
  - f. ADS Bypass Timer (High Drywell Pressure)
  - g. Manual Actuation

These functions are required to be operable in Mode 1, and in Modes 2 and 3 with reactor steam dome pressure greater than [150] psig.

Condition G states, "As required by Required Action A.1 and referenced in Table 3.3.5.1-1."

Required Action G.1 states, "Declare ADS valves inoperable," with a Completion Time of "1 hour from discovery of loss of ADS initiation capability in both trip systems."

In the BWR/4 TS, a Note to Required Action G.1 states that the Required Action only applies to Functions 4.c, 4.e, 4.f, 4.g, 5.c, 5.e, 5.f, and 5.g.

In the BWR/6 TS, a Note to Required Action G.1 states that the Required Action only applies to Functions 4.c, 4.e, 4.f, 4.g, 5.c, 5.e, and 5.f.

Required Action G.2 states, "Restore Channel to OPERABLE status." The Completion Time is 8 days unless either BWR/4 HPCI / BWR/6 HPCS, or the Reactor Core Isolation Cooling (RCIC) system are concurrently inoperable, in which case the Completion Time is halved to 96 hours (4 days). Both Completion Times provide the option to use a Risk Informed Completion Time if that program has been implemented.

If the affected channel is not restored to operable status within the specified Completion Time, Required Action H.1 requires immediately declaring the associated supported features (i.e., all ADS valves) inoperable. TS 3.5.1, "ECCS – Operating," Condition H, which addresses inoperability of two or more ADS valves would apply. The NUREG-1433 Actions require the plant to be in Mode 3 within 12 hours, and to reduce reactor steam pressure to  $\leq [150]$  psig within 36 hours. The NUREG-1434 Actions require entry into Mode 3 within 12 hours.

### **2.3. Reason for the Proposed Change**

Condition G is currently referenced from NUREG-1433 Functions 4.c, 4.e, 4.f, 4.g, 4.h, 5.c, 5.e, 5.f, 5.g, and 5.h, and NUREG-1434 Functions 4.c, 4.e, 4.f, 4.g, 4.h, 5.c, 5.e, 5.f, and 5.g. Inoperability of a single channel ultimately, if not restored after a maximum of 8 days, results in entry into Condition H, the immediate declaration of the ADS valves as inoperable, and a plant shutdown. These actions are not entirely consistent with the design. With respect to the ECCS pump discharge pressure permissives, each ADS trip system requires only two pressure channels associated with one low-pressure ECCS pump to be operable to perform the safety function and a single inoperable channel cannot render the ADS initiation capability inoperable. Required Action G.1 requires a declaration of ADS valve inoperability one hour from discovery of loss of ADS initiation capability in both systems. The Bases are inaccurate in what results in a loss of ADS initiation capability in both trip systems. Required Action G.2 applies when any of the low pressure ECCS Pump Discharge Pressure – High channels are inoperable in either ADS trip system. The Completion Time is based on discovery of loss of ADS initiation capability for one trip system. For each of these Required Actions, there is not a loss of ADS initiation capability if there are at least two ECCS Pump Discharge Pressure – High channels for one low pressure ECCS pump operable in either ADS Trip System.

Additionally, Required Action G.2 is overly restrictive when applied to BWR/4 Functions 4.h and 5.h (Manual Initiation), and BWR/6 Functions 4.h and 5.g (Manual Initiation). The Manual Initiation function is not assumed in any accident or transient analysis. Therefore, there is not a loss of credited ADS initiation capability with this function inoperable, and it is overly restrictive to declare the ADS valves inoperable when this function is inoperable.

### **2.4. Description of the Proposed Change**

The proposed change revises the TS 3.3.5.1 Action G and adds a new Action H.

NUREG-1433:

- Table 3.3.5.1-1 is revised to reference Action H instead of Action G for Functions 4.e, 4.f, 4.h, 5.e, 5.f, and 5.h.
- TS 3.3.5.1, Required Action G.1, is revised to delete the Note.
- TS 3.3.5.1 is revised to add a new Condition H.
  - The Condition states, "As required by Required Action A.1 and referenced in Table 3.3.5.1-1."
  - Required Action H.1 states, "Declare ADS valves inoperable," and is modified by two Notes. The first Note limits the Required Action's applicability to Functions 4.e, 4.f, 5.e, and 5.f. The second Note limits the Required Actions applicability to when both ADS Trip Systems lose initiation capability due to Core Spray/LPCI Discharge

- Pressure - High channels being inoperable." The Completion Time is "1 hour from discovery of loss of ADS initiation capability in both trip systems."
- Required Action H.2 states, "Restore affected channels to Operable status." It is modified by two Notes. The first Note limits the Required Action's applicability to Functions 4.e, 4.f, 5.e, and 5.f. The second Note limits the Required Actions applicability to when one ADS Trip System loses initiation capability due to Core Spray/LPCI Discharge Pressure – High channels being inoperable. The Completion Time is 96 hours from discovery of loss of ADS initiation capability in one trip system concurrent with HPCI or RCIC inoperable, and 8 days from discovery of loss of ADS initiation capability in one trip system. The option of including a Risk Informed Completion Time alternative is included, but is outside the scope of this traveler to provide the technical justification.
  - Required Action H.3 states, "Restore channel to OPERABLE status," with a Completion Time of "30 days."
  - Current Action H is renamed Action I, and is modified to include the revised Condition H.

NUREG-1434:

- Table 3.3.5.1-1 is revised to reference Action H instead of Action G for Functions 4.e, 4.f, 4.h, 5.e, and 5.g.
- TS 3.3.5.1, Required Action G.1, is revised to delete the Note.
- TS 3.3.5.1 is revised to add a new Condition H.
  - The Condition states, "As required by Required Action A.1 and referenced in Table 3.3.5.1-1."
  - Required Action H.1 states, "Declare ADS valves inoperable," and is modified by two Notes. The first Note limits the Required Action's applicability to Functions 4.e, 4.f, and 5.e. The second Note limits the Required Action's applicability to when ADS Trip Systems A and B lose initiation capability due to LPCS/LPCI Discharge Pressure - High channels inoperable." The Completion Time is "1 hour from discovery of loss of ADS initiation capability in both trip systems."
  - Required Action H.2 states, "Restore affected channels to OPERABLE status." It is modified by two Notes. The first Note limits the Required Action's applicability to Functions 4.e, 4.f, and 5.e. The second Note limits the Required Action's applicability to when one ADS Trip System loses initiation capability due to LPCS/LPCI Discharge Pressure – High channels being inoperable. The Completion Time is 96 hours from discovery of loss of ADS initiation capability in one trip system concurrent with HPCS or RCIC inoperable," and 8 days from discovery of loss of ADS initiation capability in one trip system. The option of including a Risk Informed Completion Time alternative is included, but is outside the scope of this traveler to provide the technical justification.
  - Required Action H.3 states, "Restore channel to OPERABLE status," with a Completion Time of "30 days."
- Current Action H is renamed Action I, and is modified to include the revised Condition H.

An inconsistency was discovered in the presentation of Risk Informed Completion Times (RICTs) applicable to Completion Times that state "from discovery." The existing NUREG-1433 and NUREG-1434 Completion Time presentations in TS 3.3.5.1 are different, and the NUREG-1434 Completion Time presentations in TS 3.3.5.1 and TS 3.8.1 are different. The Completion Times are revised to provide consistency and clarity, without changing the intent of the TS.

The TS Bases are revised to reflect these changes, and in particular to define when ADS trip system initiation capability is lost relative to the ECCS Pump Discharge Pressure – High functions. An additional Bases change is made to correct an error in the G.1 and G.2 Bases. The third paragraph describes “allowing time for restoration or tripping of channels.” “Tripping channels” is not an option for Condition G, so this is deleted from the Bases. The regulation at Title 10 of the Code of Federal Regulations (10 CFR), Part 50.36, states, "A summary statement of the bases or reasons for such specifications, other than those covering administrative controls, shall also be included in the application, but shall not become part of the technical specifications." A licensee may make changes to the TS Bases without prior NRC review and approval in accordance with the Technical Specifications Bases Control Program. The proposed TS Bases changes are consistent with the proposed TS changes and provide the purpose for each requirement in the specification consistent with the Commission's Final Policy Statement on Technical Specifications Improvements for Nuclear Power Reactors, dated July 22, 1993 (58 FR 39132). Therefore, the Bases changes are provided for information and approval of the Bases is not requested.

A model application is attached. The model may be used by licensees desiring to adopt the traveler following NRC approval.

### **3. TECHNICAL EVALUATION**

The ADS provides redundancy for the single high-pressure ECCS subsystem. In the event of failure of the high-pressure ECCS subsystem, the ADS valves open to rapidly reduce the reactor vessel pressure to the point at which a low-pressure ECCS pump can inject water. One low-pressure ECCS subsystem is needed as a source of coolant once ADS has depressurized the reactor vessel.

There are two ADS trip systems, designated as ADS Trip Systems A and B. A single ADS trip system can initiate opening of the ADS valves constituting "ADS initiation capability." Thus, "ADS initiation capability" is only lost when both trip systems are unable to initiate opening of the ADS valves. Either trip system can open the ADS relief valves if drywell pressure and reactor vessel water level conditions are satisfied, the ADS initiation timers have completed, and one low-pressure ECCS pump is operating as indicated by pump discharge pressure. Indication that one low-pressure ECCS pump is operating is achieved by two operable channels of discharge pressure. Both channels must indicate the necessary discharge pressure for the pump to be recognized as operating. Therefore, ADS initiation capability is only lost if one or more pump discharge pressure sensors are inoperable in all low-pressure ECCS pumps in both ADS trip systems.

There are a some BWR/4 plants with an ADS initiation design that varies from the design assumed in the STS. For example, at some plants the two pressure switches for each of the two Core Spray pumps and the four LPCI pumps provide an input to both ADS Trip Systems. This results in Functions 4.e and 5.e requiring four channels per Function rather than two, and Functions 4.f and 5.f requiring eight channels per Function rather than four. Another variation is for plants with two 50% capacity Core Spray pumps in each Core Spray loop with one pressure switch per Core Spray pump that provides input into both ADS Trip Systems. This also results in Functions 4.e and 5.e requiring four channels per Function rather than two. However, these variations have no effect on the applicability of the traveler since new Condition H is written broadly enough to accommodate plant-specific design differences. Required Action H.1 will be applicable to ADS low pressure channel inoperabilities that are sufficient to result in inoperability of both ADS trip systems. Required Action H.2 will be applicable to ADS low pressure channel inoperabilities that are sufficient to result in inoperability of only one ADS trip system. No changes to the proposed TS are needed for these design differences. Any necessary Bases changes will be incorporated by the licensee. A review of the fleet BWR/5 and BWR/6 TS did not reveal any variations from STS.

The BWR standard TS do not reflect the diversity and redundancy of the ADS initiation logic. NUREG-0123, "Standard Technical Specifications for General Electric Boiling Water Reactors," draft Revision 4 (which was the basis for development of the modern BWR standard TS), utilized the same Actions for inoperable ADS, Core Spray System, and Low Pressure Coolant Injection instrumentation channels. NEDC-31681, "Improved BWR Technical Specifications," April 1989, provided the proposed BWROG improved TS. The topical report provided 24 hours to place any inoperable ADS instrumentation channel in trip or to ensure each channel per function in one ADS trip system was operable or tripped. The Bases stated that one ADS trip system is capable of initiating ADS, implying that all channels supporting one trip system must be operable. This does not reflect the ADS initiation design. The issued standard TS (NUREG-1433 and NUREG-1434) Actions have not changed between Revision 0 and Revision 5, other than the addition of Risk Informed Completion Times.

Table 3.3.5.1-1 is revised such that Action G is only referenced from Functions 4.c, 4.g, 5.c and 5.g (ADS Initiation Timer and ADS Low Water Level Actuation Timer) for NUREG-1433, and Functions 4.c, 4.g, 5.c, and 5.f (ADS Initiation Timer and ADS Bypass Timer [High Drywell pressure]) for NUREG-1434. If these Functions are inoperable, the ADS automatic initiation function is unavailable. Therefore, the ADS valves must be declared inoperable if both ADS initiation timers and ADS low water level actuation timers/ADS high drywell pressure bypass times are inoperable. If only one ADS initiation timer or one ADS low water level actuation timer/ADS high drywell pressure bypass timer is inoperable, the existing Required Action and Completion Time for restoring the inoperable Function is unchanged. With the changes to Table 3.3.5.1-1, the existing Required Action G.1 Note is no longer needed, and the Note is deleted.

The bypass timer functions are not credited in the accident analysis. With a timer function inoperable, manual ADS actuation would still be possible. However, because the manual initiation functions are assigned to Condition H, it would be possible for both the bypass timer functions and the manual initiation functions to be inoperable if the bypass timer functions were

also assigned to Condition H, resulting in an inability to initiate ADS. Therefore, the bypass timer functions remain assigned to Condition G.

NUREG-1433 Table 3.3.5.1-1 is revised to reference Condition H from Functions:

4. ADS Trip System A
  - e. Core Spray Pump Discharge Pressure – High
  - f. Low Pressure Coolant Injection Pump Pressure – High
  - h. Manual Actuation
5. ADS Trip System B
  - e. Core Spray Pump Discharge Pressure – High
  - f. Low Pressure Coolant Injection Pump Pressure – High
  - h. Manual Actuation

NUREG-1434 Table 3.3.5.1-1 is revised to reference Condition H from Functions:

4. ADS Trip System A
  - e. LPCS Pump Discharge Pressure – High
  - f. LPCI Pump A Discharge Pressure – High
  - h. Manual Actuation
5. ADS Trip System B
  - e. LPCI Pumps B & C Discharge Pressure – High
  - g. Manual Actuation

Required Action H.1 is applicable to NUREG-1433 Functions 4.e, 4.f, 5.e, and 5.f, and NUREG-1434 Functions 4.e, 4.f, and 5.e, which are the low pressure ECCS pump high discharge pressure signals. These signals indicate that the associated low pressure pump is operating. Any one low pressure pump with two operable pump high discharge pressure signals can initiate ADS. Therefore, Required Action H.1 states, "Declare ADS valves inoperable when ADS Trip Systems A and B lose initiation capability due to Core Spray/LPCI Discharge Pressure - High channels inoperable." The Completion Time is "1 hour from discovery of loss of ADS initiation capability in both trip systems." Therefore, if there are no low pressure ECCS pumps with two operable Discharge Pressure - High channels, an ADS initiation signal cannot be provided from Trip System A or B and the ADS valves must be declared inoperable.

Required Action H.2 is also applicable to NUREG-1433 Functions 4.e, 4.f, 5.e, and 5.f, and NUREG-1434 Functions 4.e, 4.f, and 5.e, the low pressure pump high discharge pressure signals. Required Action H.2 is applicable since the loss of ADS initiation capability is limited to a single trip system and requires restoring all inoperable low pressure ECCS Pump Discharge Pressure - High channels to operable status within 8 days if HPCI or RCIC is operable, or 4 days if they are not operable. Both Completion Times have the option to apply a Risk Informed Completion Time if approved for the plant. These Completion Times are the same as current Required Action G.2.

Required Action H.3 is applicable to all Functions that reference Condition H, and is the only Required Action applicable to NUREG-1433 Functions 4.h and 5.h, "Manual Initiation," and to NUREG-1434 Functions 4.h and 5.g, "Manual Initiation." This function is not credited in any

accident analysis, and a 30-day Completion Time is justified. Additionally, the 30-day Completion Time of Required Action H.3 is acceptable, based on operating experience, considering the multiple channels available for meeting the low pressure ECCS discharge pressure permissive, and the availability of automatic ADS initiation.

Renumbering the default Action H as Action I is an administrative change to reflect the addition of new Action H, as is the inclusion of new Action H in the scope of the Action I Condition. The Bases to RAs B, C, D, E, F, G, and H reference new Condition I.

#### Correction of Inconsistency Regarding the Presentation of Risk Informed Completion Times

Existing NUREG-1433, TS 3.3.5.1, Required Action F.2, has multiple Completion Times:

96 hours from discovery of inoperable channel concurrent with HPCI or reactor core isolation cooling (RCIC) inoperable

[OR

In accordance with the Risk Informed Completion Time Program]

AND

8 days

[OR

In accordance with the Risk Informed Completion Time Program]

However, in NUREG-1434, the Required Action F.2 Completion Time states:

96 hours [or in accordance with the Risk Informed Completion Time Program] from discovery of inoperable channel concurrent with HPCS or reactor core isolation cooling (RCIC) inoperable

AND

8 days

[OR

In accordance with the Risk Informed Completion Time Program]

The only instances in the BWR and PWR STS of a modified "time zero" Completion Time with the option to apply a RICT are in NUREG-1433 and NUREG-1434 TS 3.3.5.1, Required Actions F.2 and G.2, and NUREG-1434, TS 3.8.1, Required Action A.3. These presentations are inconsistent. This inconsistency was introduced in TSTF-505, "Provide Risk-Informed Extended Completion Times," which was incorporated into Revision 5 of the STS.

Section 1.3 of the STS describes modified "time zero" Completion Times:

Unless otherwise specified, the Completion Time begins when a senior licensed operator on the operating shift crew with responsibility for plant operations makes the determination that an LCO is not met and an ACTIONS Condition is entered. The "otherwise specified" exceptions are varied, such as a Required Action Note or Surveillance Requirement Note that provides an alternative time to perform specific tasks, such as testing, without starting the Completion Time. While utilizing the Note, should a Condition be applicable for any reason not addressed by the Note, the Completion Time begins. Should the time allowance in the Note be exceeded, the Completion Time begins at that point. The exceptions may also be incorporated into the Completion Time. For example, LCO 3.8.1, "AC Sources - Operating," Required Action B.2, requires declaring required feature(s) supported by an inoperable diesel generator, inoperable when the redundant required feature(s) are inoperable. The Completion Time states, "4 hours from discovery of Condition B concurrent with inoperability of redundant required feature(s)." In this case the Completion Time does not begin until the conditions in the Completion Time are satisfied.

...

The above Completion Time extension does not apply to a Completion Time with a modified "time zero." This modified "time zero" may be expressed as a repetitive time (i.e., "once per 8 hours," where the Completion Time is referenced from a previous completion of the Required Action versus the time of Condition entry) or as a time modified by the phrase "from discovery . . ."

Based on this discussion, the appropriate presentation for a Completion Time with a modified "time zero" and a RICT option is as used in the NUREG-1434 TS 3.3.5.1, Required Action F.2, "96 hours [or in accordance with the Risk Informed Completion Time Program] from discovery of inoperable channel concurrent with HPCS or reactor core isolation cooling (RCIC) inoperable." This presentation makes clear that the RICT begins "from discovery" and not when the Actions Condition is entered. Stating the RICT option as a separate Completion Time from the modified "time zero" would require the RICT to begin on entry into the Actions Condition, which is not the intent. As stated in the Required Action F.1 and F.2 Bases, "If either HPCS or RCIC is inoperable, the time is shortened to 96 hours. [Alternatively, a Completion Time can be determined in accordance with the Risk Informed Completion Time Program.] If the status of HPCS or RCIC changes such that the Completion Time changes from 8 days to 96 hours, the 96 hours begins upon discovery of HPCS or RCIC inoperability."

For consistency and clarity, the NUREG-1433, TS 3.3.5.1, Required Action F.2 and G.2 Completion Times, and the NUREG-1434, TS 3.8.1, Required Action A.3 Completion Time are revised to include the RICT option in the modified "time zero" Completion Time.

#### 4. REGULATORY EVALUATION

The regulation at Title 10 of the CFR Section 50.36(b) requires:

Each license authorizing operation of a ... utilization facility ... will include technical specifications. The technical specifications will be derived from the analyses and evaluation included in the safety analysis report, and amendments thereto, submitted pursuant to [10 CFR] 50.34 ["Contents of applications; technical information"]. The Commission may include such additional technical specifications as the Commission finds appropriate.

Per 10 CFR 50.90, whenever a holder of a license desires to amend the license, application for an amendment must be filed with the Commission, fully describing the changes desired, and following as far as applicable, the form prescribed for original applications.

Per 10 CFR 50.92(a), in determining whether an amendment to a license will be issued to the applicant, the Commission will be guided by the considerations which govern the issuance of initial licenses to the extent applicable and appropriate.

Section IV, "The Commission Policy," of the "Final Policy Statement on Technical Specifications Improvements for Nuclear Power Reactors" (58 FR 39132), dated July 22, 1993, states in part that improved STS have been developed and will be maintained for each NSSS owners group. The Commission Policy encourages licensees to use the improved STS as the basis for plant-specific Technical Specifications." The industry's proposal of travelers and the NRC's approval of travelers is the method used to maintain the improved STS as described in the Commission's Policy. Following NRC approval, licensees adopt travelers into their plant-specific technical specifications following the requirements of 10 CFR 50.90. Therefore, the traveler process facilitates the Commission's policy while satisfying the requirements of the applicable regulations.

The regulation at 10 CFR 50.36(a)(1) also requires the application to include a "summary statement of the bases or reasons for such specifications, other than those covering administrative controls.

In conclusion, based on the considerations discussed above, (1) there is reasonable assurance that the health and safety of the public will not be endangered by operation in the proposed manner, (2) such activities will be conducted in compliance with the Commission's regulations, and (3) the approval of the proposed change will not be inimical to the common defense and security or to the health and safety of the public.

#### 5. REFERENCES

None

## Attachment 1

## Typical BWR/4 ADS Logic Diagram

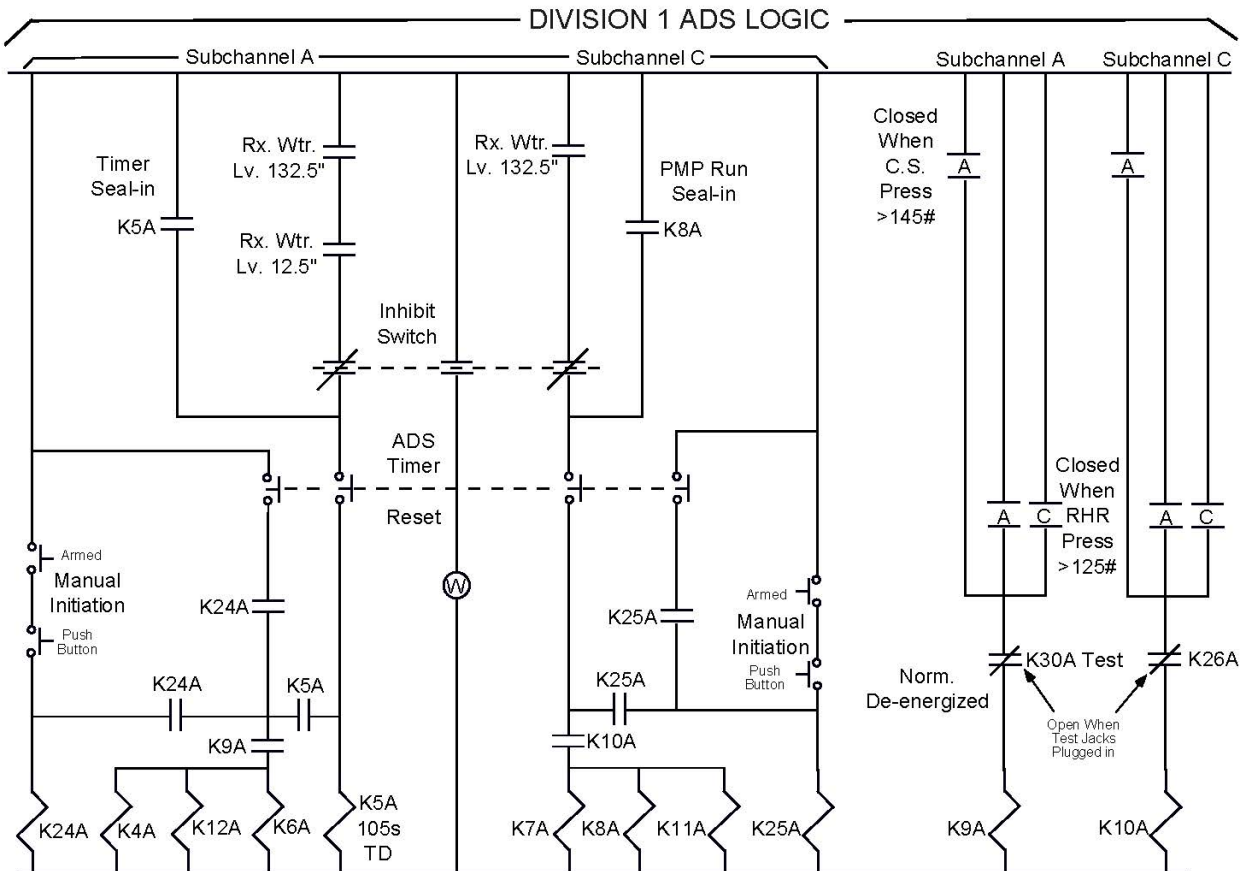

K5A - Energized when 105 sec. timer times out, creates a seal in around Rx vl. init. inputs.

K6A & K7A - Both must be energized to operate the "A" solenoids.

K9A & K10A - Energizes when "A" C.S. pump disch. pressure >145# or when "A" or "C" RHR pump discharge pressure >125#.

K24A & K25A - Energized during manual initiation.

Inhibit Switch - Prevents 12.5" & -132.5 Rx water level initiation input signal.

Timer Reset - Resets timer & will abort initiation.

Figure 10.2-4 ADS Auto & Man Init Division I Logic

Reference: General Electric BWR/4 Systems Technology Manual, Chapter 10.2, "Automatic Depressurization System," (NRC Agencywide Documents Access and Management System (ADAMS) Accession No. ML11258A366)

The ADS logic has two divisions. Figure 10.2-4 shows ADS Division I. ADS Division II is similar. Either of the ADS divisions can initiate ADS. Each ADS division has two subchannels. ADS Division I includes Subchannels A & C and ADS Division II includes Subchannels B & D. When all of the following conditions are met, the ADS logic circuits will energize the ADS solenoid pilot valves to open the ADS SRVs:

- Reactor Water Level 1,
- Reactor Water Level 3 (Confirmation of low level condition),
- Discharge pressure sensed at one LPCI pump or at one CS pump, and
- 105 second time delay as determined by an ADS timer.

The pump discharge condition is required to ensure that there is low pressure injection available before depressurization. The ADS Channels will not initiate depressurization until there is indication that at least one CS or one LPCI pump is running.

Note: The logic diagram does not necessarily fully represent the ADS logic of the STS reference plant.

Attachment 2

Example BWR/6 ADS Logic Diagram

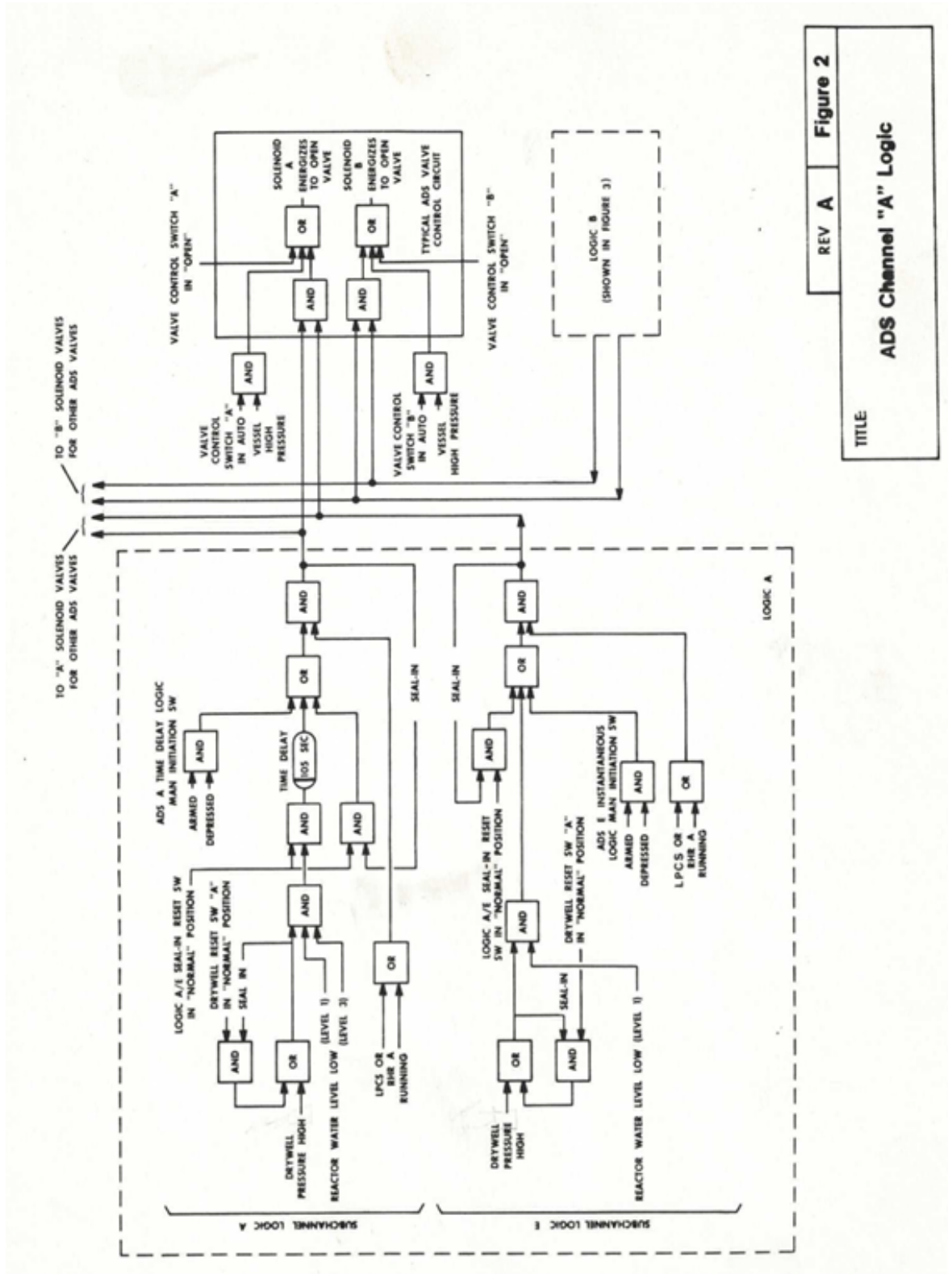

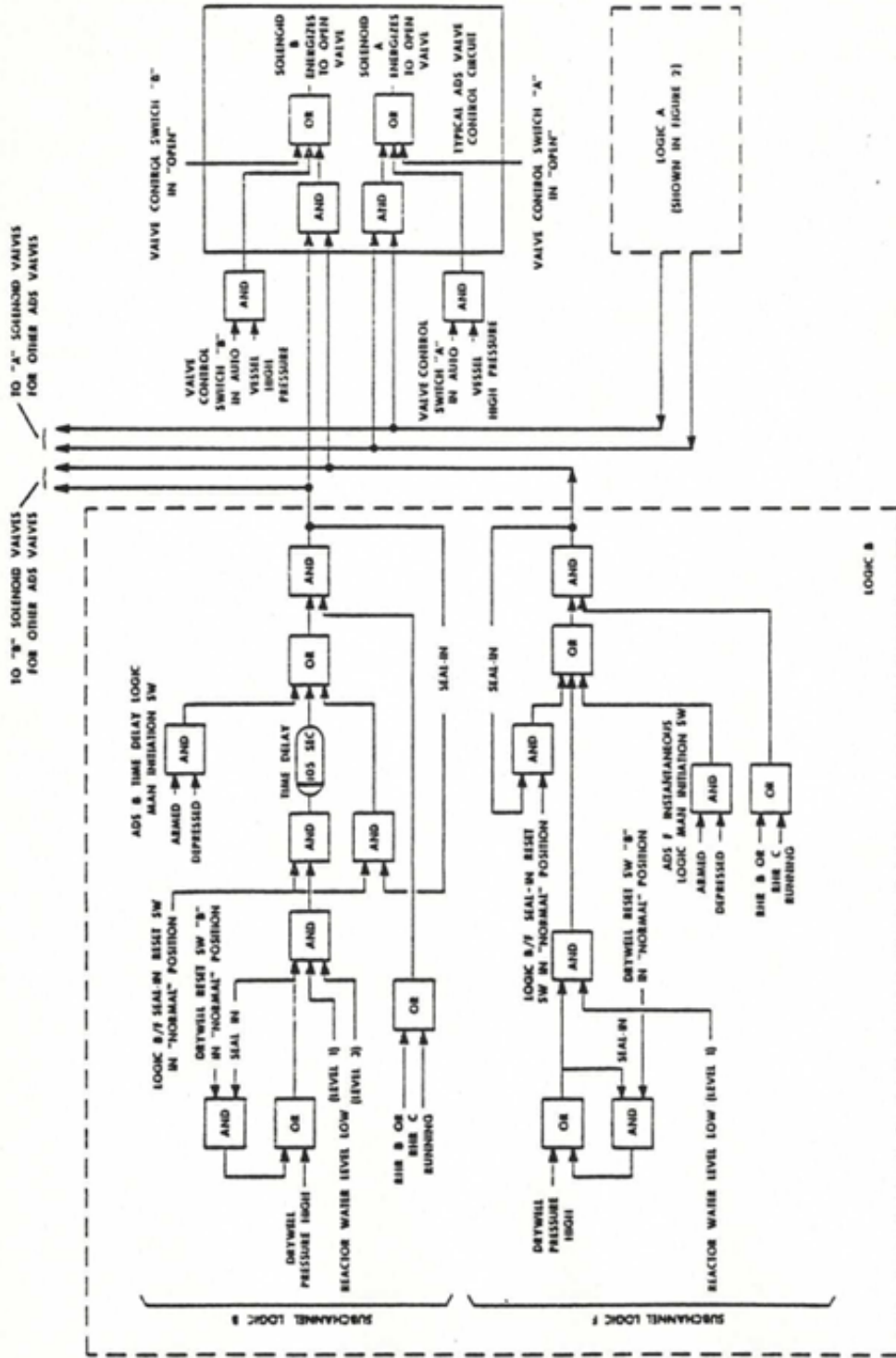

REV 0 **Figure 3**  
 TITLE: ADS Channel "B" Logic

Reference: General Electric BWR/6 Systems Technology Manual, Chapter 63, "Automatic Depressurization System"

Figures 2 and 3 depict ADS logic channel A and logic channel B, respectively. The automatic depressurization signal can be generated by either ADS logic channel. Logic channel A is divided into Subchannels A and E. Logic channel B is divided into Subchannels B and F. All the logic requirements of both subchannels must be satisfied for the corresponding logic channel to generate an initiation signal.

Confirmation of at least one low pressure ECCS pump in operation is necessary to complete the ADS logic initiation signal. An ECCS pump operating signal is generated by two pairs of pressure transmitters from two of the low pressure ECCS pumps. Subchannel A of the ADS logic receives inputs from the LPCS pump and RHR pump A, while Subchannel B receives inputs from RHR pumps B and C. One pair of pressure instruments inputs signals (one from each pump monitored by a particular channel) to each logic subchannel, and a signal from either pump's pressure transmitter is sufficient for a permissive signal from that subchannel.

Note: The logic diagram does not necessarily fully represent the ADS logic of the STS reference plant.

**Model Application**

[DATE]

10 CFR 50.90

ATTN: Document Control Desk  
U.S. Nuclear Regulatory Commission  
Washington, DC 20555-0001

DOCKET NO.PLANT NAME

50-[xxx]

SUBJECT: Application to Revise Technical Specifications to Adopt  
TSTF-592, "Revise Automatic Depressurization System (ADS)  
Instrumentation Requirements"

Pursuant to 10 CFR 50.90, [LICENSEE] is submitting a request for an amendment to the Technical Specifications (TS) for [PLANT NAME, UNIT NOS.].

[LICENSEE] requests adoption of TSTF-592, "Revise Automatic Depressurization System (ADS) Instrumentation Requirements." The Technical Specifications (TS) 3.3.5.1, "Emergency Core Cooling System (ECCS) Instrumentation," Actions are revised to reflect the plant design and the safety significance of inoperable ADS monitoring channels.

The enclosure provides a description and assessment of the proposed changes. Attachment 1 provides the existing TS pages marked to show the proposed changes. Attachment 2 provides revised (clean) TS pages. Attachment 3 provides the existing TS Bases pages marked to show revised text associated with the proposed TS changes and is provided for information only.

[[LICENSEE] requests that the amendment be reviewed under the Consolidated Line Item Improvement Process (CLIIP).] Approval of the proposed amendment is requested within 6 months of acceptance. Once approved, the amendment shall be implemented within [ ] days.

There are no regulatory commitments made in this submittal.

In accordance with 10 CFR 50.91, a copy of this application, with attachments, is being provided to the designated [STATE] Official.

[In accordance with 10 CFR 50.30(b), a license amendment request must be executed in a signed original under oath or affirmation. This can be accomplished by attaching a notarized affidavit confirming the signature authority of the signatory, or by including the following statement in the cover letter: "I declare under penalty of perjury that the foregoing is true and correct. Executed on (date)." The alternative statement is pursuant to 28 USC 1746. It does not require notarization.]

If you should have any questions regarding this submittal, please contact [NAME, TELEPHONE NUMBER].

Sincerely,

[Name, Title]

Enclosure: Description and Assessment

Attachments: 1. Proposed Technical Specification Changes (Mark-Up)  
2. Revised Technical Specification Pages  
3. Proposed Technical Specification Bases Changes (Mark-Up) – For Information Only

[The attachments are to be provided by the licensee and are not included in the model application.]

cc: NRC Project Manager  
NRC Regional Office  
NRC Resident Inspector  
State Contact

## ENCLOSURE

## DESCRIPTION AND ASSESSMENT

## 1.0 DESCRIPTION

[LICENSEE] requests adoption of TSTF-592, "Revise Automatic Depressurization System (ADS) Instrumentation Requirements." The Technical Specifications (TS) 3.3.5.1, "Emergency Core Cooling System (ECCS) Instrumentation," Actions are revised to reflect the plant design and the safety significance of inoperable ADS monitoring channels.

## 2.0 ASSESSMENT

## 2.1 Applicability of Safety Evaluation

[LICENSEE] has reviewed the safety evaluation for TSTF-592 provided to the Technical Specifications Task Force in a letter dated [DATE]. This review included a review of the NRC staff's evaluation, as well as the information provided in TSTF-592. [LICENSEE] has concluded that the justifications presented in TSTF-592 and the safety evaluation prepared by the NRC staff are applicable to [PLANT, UNIT NOS.] and justify this amendment for the incorporation of the changes to the [PLANT] TS.

[Discuss differences, if any, between the plant design and the plant design assumed in the Standard Technical Specifications that are related to the proposed change and why those differences do not affect the applicability of the TSTF-592 safety evaluation to the plant.]

## 2.2 Optional Changes and Variations

[LICENSEE is not proposing any variations from the TS changes described in TSTF-592 or the applicable parts of the NRC staff's safety evaluation dated [DATE].] [LICENSEE is proposing the following variations from the TS changes described in TSTF-592 or the applicable parts of the NRC staff's safety evaluation: describe the variations]

[The [PLANT] TS utilize different [numbering][and][titles] than the Standard Technical Specifications on which TSTF-592 was based. Specifically, [describe differences between the plant-specific TS numbering and/or titles and the TSTF-592 numbering and titles.] These differences are administrative and do not affect the applicability of TSTF-592 to the [PLANT] TS.]

[The [PLANT] TS contain requirements that differ from the Standard Technical Specifications on which TSTF-592 was based but are encompassed in the TSTF-592 justification. Describe differences and why TSTF-592 is still applicable.]

[The [PLANT] ADS initiation logic design differs from the design described in the BWR/4 STS. [Describe the design differences.] This has no effect on the traveler technical justification. No changes to the proposed TS markups are required. The [PLANT] design is reflected in the proposed TS Bases. Therefore, this difference does not affect the applicability of the traveler to [PLANT].]

### 3.0 REGULATORY ANALYSIS

#### 3.1 No Significant Hazards Consideration Analysis

[LICENSEE] requests adoption of TSTF-592, "Revise Automatic Depressurization System (ADS) Instrumentation Requirements." The Technical Specifications (TS) 3.3.5.1, "Emergency Core Cooling System (ECCS) Instrumentation," Actions are revised to reflect the plant design and the safety significance of inoperable ADS monitoring channels.

[LICENSEE] has evaluated if a significant hazards consideration is involved with the proposed amendment(s) by focusing on the three standards set forth in 10 CFR 50.92, "Issuance of amendment," as discussed below:

1. Does the proposed amendment involve a significant increase in the probability or consequences of an accident previously evaluated?

Response: No

The proposed change revises the TS Actions applicable when one or more ADS monitoring channels are inoperable to be consistent with the plant design and the safety significance of the condition. The actions taken when an ADS monitoring channel is inoperable are not an initiator of any accident previously evaluated. The proposed actions implement the appropriate actions to be taken if automatic initiation of ADS is not available (i.e., declaring the ADS valves inoperable), which ensures the equipment assumed to be available to mitigate the consequences of accidents previously evaluated is available or the plant is placed in a safe condition.

Therefore, the proposed change does not involve a significant increase in the probability or consequences of an accident previously evaluated.

2. Does the proposed amendment create the possibility of a new or different kind of accident from any accident previously evaluated?

Response: No

The proposed change revises the TS Actions applicable when one or more ADS monitoring channels are inoperable to be consistent with the plant design and the safety significance of the condition. The proposed change does not affect the design function or operation of the ADS or the ADS initiation instrumentation. The proposed change does not create a new or different type of failure for the ADS or the ADS initiation instrumentation due to credible new failure mechanisms, malfunctions, or accident initiators not currently considered in the design and licensing bases.

Therefore, the proposed change does not create the possibility of a new or different kind of accident from any accident previously evaluated.

3. Does the proposed amendment involve a significant reduction in a margin of safety?

Response: No

The proposed change revises the TS Actions applicable when one or more ADS monitoring channels are inoperable to be consistent with the plant design and the safety significance of the condition. The proposed change does not affect any controlling values of parameters established in the design or licensing basis, and does not alter any design basis or safety limit.

Therefore, the proposed change does not involve a significant reduction in a margin of safety.

Based on the above, [LICENSEE] concludes that the proposed change presents no significant hazards consideration under the standards set forth in 10 CFR 50.92(c), and, accordingly, a finding of "no significant hazards consideration" is justified.

### 3.2 Conclusion

In conclusion, based on the considerations discussed above, (1) there is reasonable assurance that the health and safety of the public will not be endangered by operation in the proposed manner, (2) such activities will be conducted in compliance with the Commission's regulations, and (3) the issuance of the amendment will not be inimical to the common defense and security or to the health and safety of the public.

### 4.0 ENVIRONMENTAL EVALUATION

A review has determined that the proposed amendment would change a requirement with respect to installation or use of a facility component located within the restricted area, as defined in 10 CFR 20, or would change an inspection or surveillance requirement. However, the proposed amendment does not involve (i) a significant hazards consideration, (ii) a significant change in the types or a significant increase in the amounts of any effluents that may be released offsite, or (iii) a significant increase in individual or cumulative occupational radiation exposure. Accordingly, the proposed amendment meets the eligibility criterion for categorical exclusion set forth in 10 CFR 51.22(c)(9). Therefore, pursuant to 10 CFR 51.22(b), no environmental impact statement or environmental assessment need be prepared in connection with the proposed amendment.

**Technical Specifications and Bases Changes**

## ACTIONS (continued)

| CONDITION  | REQUIRED ACTION  | COMPLETION TIME  |
|--|--|--|
|  | F.2 Place channel in trip.   | 96 hours <b>[or in accordance with the Risk Informed Completion Time Program]</b> from discovery of inoperable channel concurrent with HPCI or reactor core isolation cooling (RCIC) inoperable<br><br><del>IOR</del><br><br><del>In accordance with the Risk Informed Completion Time Program]</del><br><br><u>AND</u><br><br>8 days<br><br><u>IOR</u><br><br>In accordance with the Risk Informed Completion Time Program] |
| G. As required by Required Action A.1 and referenced in Table 3.3.5.1-1. | G.1 <del>NOTE</del><br><del>Only applicable for Functions 4.c, 4.e, 4.f, 4.g, 5.c, 5.e, 5.f, and 5.g.</del><br><br><del>Declare ADS valves inoperable.</del><br><br><u>AND</u> | 1 hour from discovery of loss of ADS initiation capability in both trip systems  |

## ACTIONS (continued)

| CONDITION  | REQUIRED ACTION   | COMPLETION TIME  |
|--|---|--|
|  | <p>G.2 Restore channel to OPERABLE status.</p>  | <p>96 hours <b>[or in accordance with the Risk Informed Completion Time Program]</b> from discovery of inoperable channel concurrent with HPCI or RCIC inoperable</p> <p><del>IOR</del></p> <p><del>In accordance with the Risk Informed Completion Time Program]</del></p> <p><u>AND</u></p> <p>8 days</p> <p><u>IOR</u></p> <p>In accordance with the Risk Informed Completion Time Program]</p> |
| <p><b>H. As required by Required Action A.1 and referenced in Table 3.3.5.1-1.</b></p> | <p><b>H.1 -----NOTE-----</b></p> <p><b>1 Only applicable for Functions 4.e, 4.f, 5.e, and 5.f.</b></p> <p><b>2. Only applicable when both ADS trip systems are inoperable due to Core Spray/LPCI Discharge Pressure – High channels inoperable.</b></p> <p>-----</p> <p><b>Declare ADS valves inoperable.</b></p> | <p><b>1 hour from discovery of loss of ADS initiation</b></p>  |



|  |   |             |
|--|---|-------------|
| <b>IH.</b> Required Action and associated Completion Time of Condition B, C, D, E, F, <b>G</b> , or <b>GH</b> not met. | <b>IH.1</b> Declare associated supported feature(s) inoperable. | Immediately |
|--|---|-------------|

Table 3.3.5.1-1 (page 6 of 8)  
Emergency Core Cooling System Instrumentation

| FUNCTION   | APPLICABLE<br>MODES OR<br>OTHER<br>SPECIFIED<br>CONDITIONS | REQUIRED<br>CHANNELS<br>PER<br>FUNCTION | CONDITIONS<br>REFERENCED<br>FROM<br>REQUIRED<br>ACTION A.1 | SURVEILLANCE<br>REQUIREMENTS   | ALLOWABLE<br>VALUE             |
|--|--|---|--|--|--------------------------------|
| 4. ADS Trip System A   |  |   |  |  |                                |
| c. Automatic<br>Depressurization<br>System Initiation<br>Timer                   | 1, 2 <sup>(e)</sup> , 3 <sup>(e)</sup>                     | [1]                                     | G  | [SR 3.3.5.1.5]<br>SR 3.3.5.1.6   | ≤ [120] seconds                |
| d. Reactor Vessel<br>Water Level - Low,<br>Level 3<br>(Confirmatory)             | 1, 2 <sup>(e)</sup> , 3 <sup>(e)</sup>                     | [1]                                     | F  | SR 3.3.5.1.1<br>SR 3.3.5.1.2<br>[SR 3.3.5.1.3] <sup>(b)(c)</sup><br>SR 3.3.5.1.5 <sup>(b)(c)</sup><br>SR 3.3.5.1.6 | ≥ [10] inches                  |
| e. Core Spray Pump<br>Discharge Pressure<br>- High                               | 1, 2 <sup>(e)</sup> , 3 <sup>(e)</sup>                     | [2]                                     | HG   | SR 3.3.5.1.1<br>SR 3.3.5.1.2<br>[SR 3.3.5.1.3]<br>SR 3.3.5.1.5<br>SR 3.3.5.1.6                                     | ≥ [137] psig and<br>≤ [ ] psig |
| f. Low Pressure<br>Coolant Injection<br>Pump Discharge<br>Pressure - High        | 1, 2 <sup>(e)</sup> , 3 <sup>(e)</sup>                     | [4]                                     | HG   | SR 3.3.5.1.1<br>SR 3.3.5.1.2<br>[SR 3.3.5.1.3]<br>SR 3.3.5.1.5<br>SR 3.3.5.1.6                                     | ≥ [112] psig and<br>≤ [ ] psig |
| g. Automatic<br>Depressurization<br>System Low Water<br>Level Actuation<br>Timer | 1, 2 <sup>(e)</sup> , 3 <sup>(e)</sup>                     | [2]                                     | G  | [SR 3.3.5.1.5]<br>SR 3.3.5.1.6   | ≤ [13] minutes                 |
| [ h. Manual Initiation   | 1, 2 <sup>(e)</sup> , 3 <sup>(e)</sup>                     | [2]                                     | HG   | SR 3.3.5.1.6   | N/A ]                          |

- (b) If the as-found channel setpoint is outside its predefined as-found tolerance, then the channel shall be evaluated to verify that it is functioning as required before returning the channel to service.
- (c) The instrument channel setpoint shall be reset to a value that is within the as-left tolerance around the Limiting Trip Setpoint (LTSP) at the completion of the surveillance; otherwise, the channel shall be declared inoperable. Setpoints more conservative than the LTSP are acceptable provided that the as-found and as-left tolerances apply to the actual setpoint implemented in the Surveillance procedures (Nominal Trip Setpoint) to confirm channel performance. The LTSP and the methodologies used to determine the as-found and as-left tolerances are specified in [insert the facility FSAR reference or the name of any document incorporated into the facility FSAR by reference].
- (e) With reactor steam dome pressure > [150] psig.

Table 3.3.5.1-1 (page 7 of 8)  
Emergency Core Cooling System Instrumentation

| FUNCTION  | APPLICABLE MODES OR OTHER SPECIFIED CONDITIONS | REQUIRED CHANNELS PER FUNCTION | CONDITIONS REFERENCED FROM REQUIRED ACTION A.1 | SURVEILLANCE REQUIREMENTS  | ALLOWABLE VALUE                |
|---|--|--------------------------------|--|--|--------------------------------|
| 5. ADS Trip System B  |  |                                |  |  |                                |
| a. Reactor Vessel Water Level - Low Low Low, Level 1        | 1, 2 <sup>(e)</sup> , 3 <sup>(e)</sup>         | [2]                            | F  | SR 3.3.5.1.1<br>SR 3.3.5.1.2<br>[SR 3.3.5.1.3] <sup>(b)(c)</sup><br>SR 3.3.5.1.5 <sup>(b)(c)</sup><br>SR 3.3.5.1.6 | ≥ [-113] inches                |
| b. Drywell Pressure - High                                  | 1, 2 <sup>(e)</sup> , 3 <sup>(e)</sup>         | [2]                            | F  | SR 3.3.5.1.1<br>SR 3.3.5.1.2<br>[SR 3.3.5.1.3] <sup>(b)(c)</sup><br>SR 3.3.5.1.5 <sup>(b)(c)</sup><br>SR 3.3.5.1.6 | ≤ [1.92] psig                  |
| c. Automatic Depressurization System Initiation Timer       | 1, 2 <sup>(e)</sup> , 3 <sup>(e)</sup>         | [1]                            | G  | [SR 3.3.5.1.5]<br>SR 3.3.5.1.6   | ≤ [120] seconds                |
| d. Reactor Vessel Water Level - Low, Level 3 (Confirmatory) | 1, 2 <sup>(e)</sup> , 3 <sup>(e)</sup>         | [1]                            | F  | SR 3.3.5.1.1<br>SR 3.3.5.1.2<br>[SR 3.3.5.1.3] <sup>(b)(c)</sup><br>SR 3.3.5.1.5 <sup>(b)(c)</sup><br>SR 3.3.5.1.6 | ≥ [10] inches                  |
| e. Core Spray Pump Discharge Pressure - High                | 1, 2 <sup>(e)</sup> , 3 <sup>(e)</sup>         | [2]                            | <b>HG</b>                                      | SR 3.3.5.1.1<br>SR 3.3.5.1.2<br>[SR 3.3.5.1.3]<br>SR 3.3.5.1.5<br>SR 3.3.5.1.6                                     | ≥ [137] psig and<br>≤ [ ] psig |

(b) If the as-found channel setpoint is outside its predefined as-found tolerance, then the channel shall be evaluated to verify that it is functioning as required before returning the channel to service.

(c) The instrument channel setpoint shall be reset to a value that is within the as-left tolerance around the Limiting Trip Setpoint (LTSP) at the completion of the surveillance; otherwise, the channel shall be declared inoperable. Setpoints more conservative than the LTSP are acceptable provided that the as-found and as-left tolerances apply to the actual setpoint implemented in the Surveillance procedures (Nominal Trip Setpoint) to confirm channel performance. The LTSP and the methodologies used to determine the as-found and as-left tolerances are specified in [insert the facility FSAR reference or the name of any document incorporated into the facility FSAR by reference].

(e) With reactor steam dome pressure > [150] psig.

Table 3.3.5.1-1 (page 8 of 8)  
Emergency Core Cooling System Instrumentation

| FUNCTION   | APPLICABLE<br>MODES OR<br>OTHER<br>SPECIFIED<br>CONDITIONS | REQUIRED<br>CHANNELS<br>PER<br>FUNCTION | CONDITIONS<br>REFERENCED<br>FROM<br>REQUIRED<br>ACTION A.1 | SURVEILLANCE<br>REQUIREMENTS   | ALLOWABLE<br>VALUE             |
|--|--|---|--|--|--------------------------------|
| 5. ADS Trip System B   |  |   |  |  |                                |
| f. Low Pressure<br>Coolant Injection<br>Pump Discharge<br>Pressure - High        | 1, 2 <sup>(e)</sup> , 3 <sup>(e)</sup>                     | [4]                                     | HG   | SR 3.3.5.1.1<br>SR 3.3.5.1.2<br>[SR 3.3.5.1.3]<br>SR 3.3.5.1.5<br>SR 3.3.5.1.6 | ≥ [112] psig<br>and ≤ [ ] psig |
| g. Automatic<br>Depressurization<br>System Low Water<br>Level Actuation<br>Timer | 1, 2 <sup>(e)</sup> , 3 <sup>(e)</sup>                     | [2]                                     | G  | [SR 3.3.5.1.5]<br>SR 3.3.5.1.6   | ≥ [13] minutes                 |
| [ h. Manual Initiation   | 1, 2 <sup>(e)</sup> , 3 <sup>(e)</sup>                     | [2]                                     | HG   | SR 3.3.5.1.6   | NA ]                           |

(e) With reactor steam dome pressure > [150] psig.

BASES

---

## ACTIONS (continued)

Notes are also provided (the Note to Required Action B.1 and the Note to Required Action B.2) to delineate which Required Action is applicable for each Function that requires entry into Condition B if an associated channel is inoperable. This ensures that the proper loss of initiation capability check is performed. Required Action B.1 (the Required Action for certain inoperable channels in the low pressure ECCS subsystems) is not applicable to Function 2.e, since this Function provides backup to administrative controls ensuring that operators do not divert LPCI flow from injecting into the core when needed. Thus, a total loss of Function 2.e capability for 24 hours is allowed, since the LPCI subsystems remain capable of performing their intended function.

The Completion Time is intended to allow the operator time to evaluate and repair any discovered inoperabilities. This Completion Time also allows for an exception to the normal "time zero" for beginning the allowed outage time "clock." For Required Action B.1, the Completion Time only begins upon discovery that a redundant feature in the same system (e.g., both CS subsystems) cannot be automatically initiated due to inoperable, untripped channels within the same Function as described in the paragraph above. For Required Action B.2, the Completion Time only begins upon discovery that the HPCI System cannot be automatically initiated due to two inoperable, untripped channels for the associated Function in the same trip system. The 1 hour Completion Time from discovery of loss of initiation capability is acceptable because it minimizes risk while allowing time for restoration or tripping of channels.

Because of the diversity of sensors available to provide initiation signals and the redundancy of the ECCS design, an allowable out of service time of 24 hours has been shown to be acceptable (Ref. 6) to permit restoration of any inoperable channel to OPERABLE status.

[Alternatively, a Completion Time can be determined in accordance with the Risk Informed Completion Time Program.] If the inoperable channel cannot be restored to OPERABLE status within the allowable out of service time, the channel must be placed in the tripped condition per Required Action B.3. Placing the inoperable channel in trip would conservatively compensate for the inoperability, restore capability to accommodate a single failure, and allow operation to continue.

Alternately, if it is not desired to place the channel in trip (e.g., as in the case where placing the inoperable channel in trip would result in an initiation), Condition **IH** must be entered and its Required Action taken.

BASES

---

## ACTIONS (continued)

The Completion Time is intended to allow the operator time to evaluate and repair any discovered inoperabilities. This Completion Time also allows for an exception to the normal "time zero" for beginning the allowed outage time "clock." For Required Action C.1, the Completion Time only begins upon discovery that the same feature in both subsystems (e.g., both CS subsystems) cannot be automatically initiated due to inoperable channels within the same Function as described in the paragraph above. The 1 hour Completion Time from discovery of loss of initiation capability is acceptable because it minimizes risk while allowing time for restoration of channels.

Because of the diversity of sensors available to provide initiation signals and the redundancy of the ECCS design, an allowable out of service time of 24 hours has been shown to be acceptable (Ref. 6) to permit restoration of any inoperable channel to OPERABLE status.

[Alternatively, a Completion Time can be determined in accordance with the Risk Informed Completion Time Program.] If the inoperable channel cannot be restored to OPERABLE status within the allowable out of service time, Condition ~~IH~~ must be entered and its Required Action taken. The Required Actions do not allow placing the channel in trip since this action would either cause the initiation or it would not necessarily result in a safe state for the channel in all events.

D.1, D.2.1, and D.2.2

Required Action D.1 is intended to ensure that appropriate actions are taken if multiple, inoperable, untripped channels within the same Function result in a complete loss of automatic component initiation capability for the HPCI System. Automatic component initiation capability is lost if two Function 3.d channels or two Function 3.e channels are inoperable and untripped. In this situation (loss of automatic suction swap), the 24 hour allowance of Required Actions D.2.1 and D.2.2 is not appropriate and the HPCI System must be declared inoperable within 1 hour after discovery of loss of HPCI initiation capability. As noted, Required Action D.1 is only applicable if the HPCI pump suction is not aligned to the suppression pool, since, if aligned, the Function is already performed.

The Completion Time is intended to allow the operator time to evaluate and repair any discovered inoperabilities. This Completion Time also allows for an exception to the normal "time zero" for beginning the allowed outage time "clock." For Required Action D.1, the Completion Time only begins upon discovery that the HPCI System cannot be automatically aligned to the suppression pool due to two inoperable,

## BASES

---

### ACTIONS (continued)

untripped channels in the same Function. The 1 hour Completion Time from discovery of loss of initiation capability is acceptable because it minimizes risk while allowing time for restoration or tripping of channels.

Because of the diversity of sensors available to provide initiation signals and the redundancy of the ECCS design, an allowable out of service time of 24 hours has been shown to be acceptable (Ref. 6) to permit restoration of any inoperable channel to OPERABLE status.

[Alternatively, a Completion Time can be determined in accordance with the Risk Informed Completion Time Program.] If the inoperable channel cannot be restored to OPERABLE status within the allowable out of service time, the channel must be placed in the tripped condition per Required Action D.2.1 or the suction source must be aligned to the suppression pool within 24 hours per Required Action D.2.2. Placing the inoperable channel in trip performs the intended function of the channel (shifting the suction source to the suppression pool). Performance of either of these two Required Actions will allow operation to continue. If Required Action D.2.1 or D.2.2 is performed, measures should be taken to ensure that the HPCI System piping remains filled with water. Alternately, if it is not desired to perform Required Actions D.2.1 and D.2.2 (e.g., as in the case where shifting the suction source could drain down the HPCI suction piping), Condition **IH** must be entered and its Required Action taken.

#### E.1 and E.2

Required Action E.1 is intended to ensure that appropriate actions are taken if multiple, inoperable channels within the Core Spray and Low Pressure Coolant Injection Pump Discharge Flow - Low Bypass Functions result in redundant automatic initiation capability being lost for the feature(s). For Required Action E.1, the features would be those that are initiated by Functions 1.d and 2.g (e.g., low pressure ECCS). Redundant automatic initiation capability is lost if (a) two Function 1.d channels are inoperable or (b) one or more Function 2.g channels associated with pumps in LPCI subsystem A and one or more Function 2.g channels associated with pumps in LPCI subsystem B are inoperable. Since each inoperable channel would have Required Action E.1 applied separately (refer to ACTIONS Note), each inoperable channel would only require the affected low pressure ECCS pump to be declared inoperable. However, since channels for more than one low pressure ECCS pump are inoperable, and the Completion Times started concurrently for the channels of the low pressure ECCS pumps, this results in the affected low pressure ECCS pumps being concurrently declared inoperable.

## BASES

---

### ACTIONS (continued)

in the ECCS design, and the low probability of a DBA occurring during the allowed out of service time. If the inoperable channel cannot be restored to OPERABLE status within the allowable out of service time, Condition **IH** must be entered and its Required Action taken. The Required Actions do not allow placing the channel in trip since this action would not necessarily result in a safe state for the channel in all events.

#### F.1 and F.2

Required Action F.1 is intended to ensure that appropriate actions are taken if multiple, inoperable, untripped channels within similar ADS trip system A and B Functions result in redundant automatic initiation capability being lost for the ADS. Redundant automatic initiation capability is lost if either (a) one Function 4.a channel and one Function 5.a channel are inoperable and untripped, (b) one Function 4.b channel and one Function 5.b channel are inoperable and untripped, or (c) one Function 4.d channel and one Function 5.d channel are inoperable and untripped.

In this situation (loss of automatic initiation capability), the 96 hour or 8 day allowance, as applicable, of Required Action F.2 is not appropriate and all ADS valves must be declared inoperable within 1 hour after discovery of loss of ADS initiation capability.

The Completion Time is intended to allow the operator time to evaluate and repair any discovered inoperabilities. This Completion Time also allows for an exception to the normal "time zero" for beginning the allowed outage time "clock." For Required Action F.1, the Completion Time only begins upon discovery that the ADS cannot be automatically initiated due to inoperable, untripped channels within similar ADS trip system Functions as described in the paragraph above. The 1 hour Completion Time from discovery of loss of initiation capability is acceptable because it minimizes risk while allowing time for restoration or tripping of channels.

Because of the diversity of sensors available to provide initiation signals and the redundancy of the ECCS design, an allowable out of service time of 8 days has been shown to be acceptable (Ref. 6) to permit restoration of any inoperable channel to OPERABLE status if both HPCI and RCIC are OPERABLE. [Alternatively, a Completion Time can be determined in accordance with the Risk Informed Completion Time Program.] If either HPCI or RCIC is inoperable, the time is shortened to 96 hours. If the status of HPCI or RCIC changes such that the Completion Time changes

## BASES

## ACTIONS (continued)

from 8 days to 96 hours [or in accordance with the Risk Informed Completion Time Program], the 96 hours begins upon discovery of HPCI or RCIC inoperability. However, the total time for an inoperable, untripped channel cannot exceed 8 days. If the status of HPCI or RCIC changes such that the Completion Time changes from 96 hours to 8 days, the "time zero" for beginning the 8 day "clock" begins upon discovery of the inoperable, untripped channel. If the inoperable channel cannot be restored to OPERABLE status within the allowable out of service time, the channel must be placed in the tripped condition per Required Action F.2. Placing the inoperable channel in trip would conservatively compensate for the inoperability, restore capability to accommodate a single failure, and allow operation to continue. Alternately, if it is not desired to place the channel in trip (e.g., as in the case where placing the inoperable channel in trip would result in an initiation), Condition **IH** must be entered and its Required Action taken.

G.1 and G.2

Required Action G.1 is intended to ensure that appropriate actions are taken if ~~multiple, inoperable channels within similar ADS trip system Functions result in automatic initiation capability being lost for the ADS. Automatic initiation capability is lost if either~~ (a) one Function 4.c channel and one Function 5.c channel are inoperable ~~, (b) a combination of Function 4.e, 4.f, 5.e, and 5.f channels are inoperable such that channels associated with five or more low pressure ECCS pumps are inoperable,~~ or ~~(bc)~~ one or more Function 4.g channels and one or more Function 5.g channels are inoperable.

In this situation (loss of automatic initiation capability), the 96 hour or 8 day allowance, as applicable, of Required Action G.2 is not appropriate, and all ADS valves must be declared inoperable within 1 hour after discovery of loss of ADS initiation capability **in both trip systems**. ~~The Note to Required Action G.1 states that Required Action G.1 is only applicable for Functions 4.c, 4.e, 4.f, 4.g, 5.c, 5.e, 5.f, and 5.g. Required Action G.1 is not applicable to Functions 4.h and 5.h (which also require entry into this Condition if a channel in these Functions is inoperable), since they are the Manual Initiation Functions and are not assumed in any accident or transient analysis. Thus, a total loss of manual initiation capability for 96 hours or 8 days (as allowed by Required Action G.2) is allowed.~~

The Completion Time is intended to allow the operator time to evaluate and repair any discovered inoperabilities. This Completion Time also allows for an exception to the normal "time zero" for beginning the allowed outage time "clock." For Required Action G.1, the Completion

Time only begins upon discovery that the ADS cannot be automatically initiated due to inoperable channels within similar ADS trip system Functions as described in the paragraph above. The 1 hour Completion Time from discovery of loss of initiation capability is acceptable because it minimizes risk while allowing time for restoration ~~or tripping~~ of channels.

Because of the diversity of sensors available to provide initiation signals and the redundancy of the ECCS design, an allowable out of service time of 8 days has been shown to be acceptable (Ref. 6) to permit restoration of any inoperable channel to OPERABLE status if both HPCI and RCIC are OPERABLE (Required Action G.2). [Alternatively, a Completion Time can be determined in accordance with the Risk Informed Completion Time Program.] If either HPCI or RCIC is inoperable, the time shortens to

## BASES

---

### ACTIONS (continued)

96 hours [or in accordance with the Risk Informed Completion Time Program]. If the status of HPCI or RCIC changes such that the Completion Time changes from 8 days to 96 hours, the 96 hours begins upon discovery of HPCI or RCIC inoperability. However, the total time for an inoperable channel cannot exceed 8 days. If the status of HPCI or RCIC changes such that the Completion Time changes from 96 hours to 8 days, the "time zero" for beginning the 8 day "clock" begins upon discovery of the inoperable channel. If the inoperable channel cannot be restored to OPERABLE status within the allowable out of service time, Condition **IH** must be entered and its Required Action taken. The Required Actions do not allow placing the channel in trip since this action would not necessarily result in a safe state for the channel in all events.

### H.1, H.2, and H.3

**Required Action H.1 requires that the ADS valves be declared inoperable when a combination of Functions 4.e, 4.f, 5.e, and 5.f channels are inoperable such that neither ADS Trip System A or B has two Operable Discharge Pressure – High channels associated with one low pressure ECCS pump.**

**In this situation (loss of automatic initiation capability), the 96 hour or 8 day allowance, as applicable, of Required Action H.2 is not appropriate, and all ADS valves must be declared inoperable within 1 hour after discovery of loss of ADS initiation capability in both trip systems. The Notes to Required Action H.1 state that Required Action H.1 is only applicable for Functions 4.e, 4.f, 5.e, and 5.f, and that it is only applicable when ADS Trip Systems A and B are inoperable due to Core Spray/LPCI Discharge Pressure – High functions being inoperable. Required Action H.1 is not applicable to Functions 4.h and 5.h (which also require entry into this Condition if a channel in these Functions is inoperable), since they are Manual**

Initiation Functions and are not assumed in any accident or transient analysis. Thus, a total loss of these functions for 30 days (as allowed by Required Action H.3) is allowed.

The Completion Time is intended to allow the operator time to evaluate and repair any discovered inoperabilities. This Completion Time also allows for an exception to the normal "time zero" for beginning the allowed outage time "clock." For Required Action H.1, the Completion Time only begins upon discovery that the ADS cannot be automatically initiated due to inoperable channels within similar ADS trip system Functions as described in the paragraph above. The 1 hour Completion Time from discovery of loss of initiation capability is acceptable because it minimizes risk while allowing time for restoration or tripping of channels. If the inoperable channels cannot be restored to OPERABLE status within the allowable out of service time, Condition I must be entered and its Required Action taken.

## BASES

---

### ACTIONS (continued)

Required Action H.2 is intended to ensure that appropriate actions are taken if there are not two Operable Discharge Pressure – High channels associated with one low pressure ECCS pump within one ADS trip system, which results in automatic initiation capability being lost for that ADS trip system. Because of the diversity of sensors available to provide initiation signals and the redundancy of the ECCS design, an allowable out of service time of 8 days has been shown to be acceptable (Ref. 6) to permit restoration of two inoperable Discharge Pressure – High channels associated with one low pressure ECCS Pump to OPERABLE status if both HPCI and RCIC are OPERABLE (Required Action H.2). [Alternatively, a Completion Time can be determined in accordance with the Risk Informed Completion Time Program.] If either HPCI or RCIC is inoperable, the time shortens to 96 hours [or in accordance with the Risk Informed Completion Time Program]. If the status of HPCI or RCIC changes such that the Completion Time changes from 8 days to 96 hours, the 96 hours begins upon discovery of HPCI or RCIC inoperability. However, the total time to restore the required inoperable channels to OPERABLE status cannot exceed 8 days. If the status of HPCI or RCIC changes such that the Completion Time changes from 96 hours to 8 days, the "time zero" for beginning the 8 day "clock" begins upon discovery of the inoperable channel. If the minimum required inoperable channels cannot be restored to OPERABLE status within the allowable out of service time, Condition I must be entered and its Required Action taken. The Required Actions do not allow placing the channel in trip since this action would not necessarily result in a safe state for the channel in

all events. The Notes to Required Action H.2 state that Required Action H.2 is only applicable for Functions 4.e, 4.f., 5.e, and 5.f, and that it is only applicable when one ADS trip system is inoperable due to Core Spray/LPCI Discharge Pressure – High functions being inoperable. Required Action H.2 is not applicable to Functions 4.h and 5.h (which also require entry into this Condition if a channel in these Functions is inoperable), since they are the Manual Initiation Functions and are not assumed in any accident or transient analysis. Thus, a total loss of these functions for 30 days (as allowed by Required Action H.3) is allowed.

Required Action H.3 is intended to ensure that appropriate actions are taken if inoperable channels within one ADS trip system do not result in loss of automatic initiation capability to respond to a design basis event, but require restoration per Table 3.3.5.1-1. This applies to Functions 4.e, 4.f, 4.h, 5.e, 5.f, and 5.h. The 30 day Completion Time of Required Action H.3 is acceptable, based on operating experience, considering the multiple channels available for meeting the low pressure ECCS discharge pressure permissive, and the availability of automatic ADS initiation. If the inoperable channel cannot be restored to OPERABLE status within the allowable out of service time, Condition I must be entered and its Required Action taken.

BASES

---

ACTIONS (continued)

IH.1

With any Required Action and associated Completion Time not met, the associated feature(s) may be incapable of performing the intended function, and the supported feature(s) (**Core Spray, LPCI, HPCI, or ADS**) associated with inoperable untripped channels must be declared inoperable immediately.

SURVEILLANCE  
REQUIREMENTS

-----REVIEWER'S NOTE-----  
 Certain Frequencies are based on approved topical reports. In order for a licensee to use these Frequencies, the licensee must justify the Frequencies as required by the staff SER for the topical report.  
 -----

-----REVIEWER'S NOTE-----  
 Notes b and c are applied to the setpoint verification Surveillances for each ECCS Instrumentation Functions in Table 3.3.5.1-1 unless one or more of the following exclusions apply:

## ACTIONS (continued)

| CONDITION  | REQUIRED ACTION   | COMPLETION TIME  |
|--|---|--|
|  | F.2 Place channel in trip.  | 96 hours [or in accordance with the Risk Informed Completion Time Program] from discovery of inoperable channel concurrent with HPCS or reactor core isolation cooling (RCIC) inoperable<br><br><u>AND</u><br><br>8 days<br><br><u>OR</u><br><br>In accordance with the Risk Informed Completion Time Program] |
| G. As required by Required Action A.1 and referenced in Table 3.3.5.1-1. | G.1 <del>NOTE</del><br><del>Only applicable for Functions 4.c, 4.e, 4.f, 4.g, 5.c, 5.e, and 5.f.</del><br><br><del>Declare ADS valves inoperable.</del><br><br><u>AND</u> | 1 hour from discovery of loss of ADS initiation capability in both trip systems  |

## ACTIONS (continued)

| CONDITION  | REQUIRED ACTION  | COMPLETION TIME  |
|--|--|--|
|  | <p>G.2 Restore channel to OPERABLE status.</p>   | <p>96 hours [or in accordance with the Risk Informed Completion Time Program] from discovery of inoperable channel concurrent with HPCS or RCIC inoperable</p> <p><u>AND</u></p> <p>8 days</p> <p><u>OR</u></p> <p>In accordance with the Risk Informed Completion Time Program]</p> |
| <p><b>H. As required by Required Action A.1 and referenced in Table 3.3.5.1-1.</b></p> | <p><b>H.1 -----NOTE-----</b></p> <p><b>1. Only applicable for Functions 4.e, 4.f, and 5.e.</b></p> <p><b>2. Only applicable when ADS Trip Systems A and B lose initiation capability due to LPCS/LPCI Discharge Pressure - High channels inoperable.</b></p> <p>-----</p> <p><b>Declare ADS valves inoperable.</b></p> <p><u>AND</u></p> | <p><b>1 hour from discovery of loss of ADS initiation capability in both trip systems</b></p>  |

|   |   |  |
|---|---|--|
|   | <p><b>H.2</b> -----NOTE-----<br/> <b>1. Only applicable for Functions 4.e, 4.f, and 5.e.</b><br/><br/> <b>2. Only applicable when one ADS trip system loses initiation capability due to LPCS/LPCI Discharge Pressure - High channels inoperable.</b><br/>         -----</p> <p><b>Restore affected channels to OPERABLE status.</b></p> <p><b><u>AND</u></b></p> <p><b>H.3 Restore channel to OPERABLE status.</b></p> | <p><b>96 hours [or in accordance with the Risk Informed Completion Time Program] from discovery of inoperable channel concurrent with HPCS or RCIC inoperable.</b></p> <p><b><u>AND</u></b></p> <p><b>8 days [or in accordance with the Risk Informed Completion Time Program] from the discovery of a loss of ADS initiation capability in one trip system.</b></p> <p><b>30 days</b></p> |
| <p><b>IH.</b> Required Action and associated Completion Time of Condition B, C, D, E, F, <b>G</b> or <b>GH</b> not met.</p> | <p><b>IH.1</b> Declare associated supported feature(s) inoperable.</p>  | <p>Immediately</p>   |

Table 3.3.5.1-1 (page 6 of 8)  
Emergency Core Cooling System Instrumentation

| FUNCTION  | APPLICABLE MODES OR OTHER SPECIFIED CONDITIONS | REQUIRED CHANNELS PER FUNCTION | CONDITIONS REFERENCED FROM REQUIRED ACTION A.1 | SURVEILLANCE REQUIREMENTS  | ALLOWABLE VALUE                  |
|---|--|--------------------------------|--|--|----------------------------------|
| 3. HPCS System  |  |                                |  |  |                                  |
| [ h. Manual Initiation                                      | 1, 2, 3  | [1]                            | C  | SR 3.3.5.1.6   | NA ]                             |
| 4. ADS Trip System A  |  |                                |  |  |                                  |
| a. Reactor Vessel Water Level - Low Low Low, Level 1        | 1, 2 <sup>(e)</sup> , 3 <sup>(e)</sup>         | [2]                            | F  | SR 3.3.5.1.1<br>SR 3.3.5.1.2<br>[SR 3.3.5.1.3] <sup>(b)(c)</sup><br>SR 3.3.5.1.5 <sup>(b)(c)</sup><br>SR 3.3.5.1.6 | ≥ [-152.5] inches                |
| b. Drywell Pressure - High                                  | 1, 2 <sup>(e)</sup> , 3 <sup>(e)</sup>         | [2]                            | F  | SR 3.3.5.1.1<br>SR 3.3.5.1.2<br>[SR 3.3.5.1.3] <sup>(b)(c)</sup><br>SR 3.3.5.1.5 <sup>(b)(c)</sup><br>SR 3.3.5.1.6 | ≤ [1.44] psig                    |
| c. ADS Initiation Timer                                     | 1, 2 <sup>(e)</sup> , 3 <sup>(e)</sup>         | [1]                            | G  | SR 3.3.5.1.2<br>[SR 3.3.5.1.4]<br>SR 3.3.5.1.6   | ≤ [117] seconds                  |
| d. Reactor Vessel Water Level - Low, Level 3 (Confirmatory) | 1, 2 <sup>(e)</sup> , 3 <sup>(e)</sup>         | [1]                            | F  | SR 3.3.5.1.1<br>SR 3.3.5.1.2<br>[SR 3.3.5.1.3] <sup>(b)(c)</sup><br>SR 3.3.5.1.5 <sup>(b)(c)</sup><br>SR 3.3.5.1.6 | ≥ [10.8] inches                  |
| e. LPCS Pump Discharge Pressure - High                      | 1, 2 <sup>(e)</sup> , 3 <sup>(e)</sup>         | [2]                            | HG   | SR 3.3.5.1.1<br>SR 3.3.5.1.2<br>[SR 3.3.5.1.3] <sup>(b)(c)</sup><br>SR 3.3.5.1.5 <sup>(b)(c)</sup><br>SR 3.3.5.1.6 | ≥ [125] psig and<br>≤ [165] psig |

- (b) If the as-found channel setpoint is outside its predefined as-found tolerance, then the channel shall be evaluated to verify that it is functioning as required before returning the channel to service.
- (c) The instrument channel setpoint shall be reset to a value that is within the as-left tolerance around the Limiting Trip Setpoint (LTSP) at the completion of the surveillance; otherwise, the channel shall be declared inoperable. Setpoints more conservative than the LTSP are acceptable provided that the as-found and as-left tolerances apply to the actual setpoint implemented in the Surveillance procedures [Nominal Trip Setpoint] to confirm channel performance. The LTSP and the methodologies used to determine the as-found and as-left tolerances are specified in [insert the facility FSAR reference or the name of any document incorporated into the facility FSAR by reference].
- (e) With reactor steam dome pressure > [150] psig.

Table 3.3.5.1-1 (page 7 of 8)  
Emergency Core Cooling System Instrumentation

| FUNCTION   | APPLICABLE MODES OR OTHER SPECIFIED CONDITIONS | REQUIRED CHANNELS PER FUNCTION | CONDITIONS REFERENCED FROM REQUIRED ACTION A.1 | SURVEILLANCE REQUIREMENTS  | ALLOWABLE VALUE                     |
|--|--|--------------------------------|--|--|-------------------------------------|
| 4. ADS Trip System A                                 |  |                                |  |  |                                     |
| f. LPCI Pump A Discharge Pressure - High             | 1, 2 <sup>(e)</sup> , 3 <sup>(e)</sup>         | [2]                            | HG   | SR 3.3.5.1.1<br>SR 3.3.5.1.2<br>[SR 3.3.5.1.3]<br>SR 3.3.5.1.5<br>SR 3.3.5.1.6                                     | ≥ [115] psig<br>and<br>≤ [135] psig |
| g. [ ADS Bypass Timer (High Drywell Pressure) ]      | 1, 2 <sup>(e)</sup> , 3 <sup>(e)</sup>         | [2]                            | G  | SR 3.3.5.1.2<br>[SR 3.3.5.1.4]<br>SR 3.3.5.1.6   | ≤ [9.4] minutes                     |
| [ h. Manual Initiation                               | 1, 2 <sup>(e)</sup> , 3 <sup>(e)</sup>         | [2]                            | HG   | SR 3.3.5.1.6   | NA ]                                |
| 5. ADS Trip System B                                 |  |                                |  |  |                                     |
| a. Reactor Vessel Water Level - Low Low Low, Level 1 | 1, 2 <sup>(e)</sup> , 3 <sup>(e)</sup>         | [2]                            | F  | SR 3.3.5.1.1<br>SR 3.3.5.1.2<br>[SR 3.3.5.1.3] <sup>(b)(c)</sup><br>SR 3.3.5.1.5 <sup>(b)(c)</sup><br>SR 3.3.5.1.6 | ≥ [-152.5] inches                   |
| b. Drywell Pressure - High                           | 1, 2 <sup>(e)</sup> , 3 <sup>(e)</sup>         | [2]                            | F  | SR 3.3.5.1.1<br>SR 3.3.5.1.2<br>[SR 3.3.5.1.3] <sup>(b)(c)</sup><br>SR 3.3.5.1.5 <sup>(b)(c)</sup><br>SR 3.3.5.1.6 | ≤ [1.44] psig                       |
| c. ADS Initiation Timer                              | 1, 2 <sup>(e)</sup> , 3 <sup>(e)</sup>         | [1]                            | G  | SR 3.3.5.1.2<br>[SR 3.3.5.1.4]<br>SR 3.3.5.1.6   | ≤ [117] seconds                     |

- (b) If the as-found channel setpoint is outside its predefined as-found tolerance, then the channel shall be evaluated to verify that it is functioning as required before returning the channel to service.
- (c) The instrument channel setpoint shall be reset to a value that is within the as-left tolerance around the Limiting Trip Setpoint (LTSP) at the completion of the surveillance; otherwise, the channel shall be declared inoperable. Setpoints more conservative than the LTSP are acceptable provided that the as-found and as-left tolerances apply to the actual setpoint implemented in the Surveillance procedures [Nominal Trip Setpoint] to confirm channel performance. The LTSP and the methodologies used to determine the as-found and as-left tolerances are specified in [insert the facility FSAR reference or the name of any document incorporated into the facility FSAR by reference].
- (e) With reactor steam dome pressure > [150] psig.

Table 3.3.5.1-1 (page 8 of 8)  
Emergency Core Cooling System Instrumentation

| FUNCTION  | APPLICABLE MODES OR OTHER SPECIFIED CONDITIONS | REQUIRED CHANNELS PER FUNCTION | CONDITIONS REFERENCED FROM REQUIRED ACTION A.1 | SURVEILLANCE REQUIREMENTS  | ALLOWABLE VALUE                     |
|---|--|--------------------------------|--|--|-------------------------------------|
| 5. ADS Trip System B  |  |                                |  |  |                                     |
| d. Reactor Vessel Water Level - Low, Level 3 (Confirmatory) | 1, 2 <sup>(e)</sup> , 3 <sup>(e)</sup>         | [1]                            | F  | SR 3.3.5.1.1<br>SR 3.3.5.1.2<br>[SR 3.3.5.1.3] <sup>(b)(c)</sup><br>SR 3.3.5.1.5 <sup>(b)(c)</sup><br>SR 3.3.5.1.6 | ≥ [10.8] inches                     |
| e. LPCI Pumps B & C Discharge Pressure - High               | 1, 2 <sup>(e)</sup> , 3 <sup>(e)</sup>         | [4]<br>[2 per pump]            | HG   | SR 3.3.5.1.1<br>SR 3.3.5.1.2<br>[SR 3.3.5.1.3]<br>SR 3.3.5.1.5<br>SR 3.3.5.1.6                                     | ≥ [115] psig<br>and<br>≤ [135] psig |
| f. [ADS Bypass Timer (High Drywell Pressure)]               | 1, 2 <sup>(e)</sup> , 3 <sup>(e)</sup>         | [2]                            | G  | SR 3.3.5.1.2<br>[SR 3.3.5.1.4]<br>SR 3.3.5.1.6   | ≤ [9.4] minutes                     |
| [ g. Manual Initiation                                      | 1, 2 <sup>(e)</sup> , 3 <sup>(e)</sup>         | [2]                            | HG   | SR 3.3.5.1.6   | NA ]                                |

- (b) If the as-found channel setpoint is outside its predefined as-found tolerance, then the channel shall be evaluated to verify that it is functioning as required before returning the channel to service.
- (c) The instrument channel setpoint shall be reset to a value that is within the as-left tolerance around the Limiting Trip Setpoint (LTSP) at the completion of the surveillance; otherwise, the channel shall be declared inoperable. Setpoints more conservative than the LTSP are acceptable provided that the as-found and as-left tolerances apply to the actual setpoint implemented in the Surveillance procedures [Nominal Trip Setpoint] to confirm channel performance. The LTSP and the methodologies used to determine the as-found and as-left tolerances are specified in [insert the facility FSAR reference or the name of any document incorporated into the facility FSAR by reference].
- (e) With reactor steam dome pressure > [150] psig.

## ACTIONS (continued)

| CONDITION                        | REQUIRED ACTION  | COMPLETION TIME   |
|----------------------------------|--|---|
|                                  | <p>A.2 Declare required feature(s) with no offsite power available inoperable when the redundant required feature(s) are inoperable.</p> <p><u>AND</u></p> <p>A.3 Restore [required] offsite circuit to OPERABLE status.</p> | <p>24 hours from discovery of no offsite power to one division concurrent with inoperability of redundant required feature(s)</p> <p>72 hours</p> <p><u>IOR</u></p> <p>In accordance with the Risk Informed Completion Time Program]</p> <p><u>AND</u></p> <p>24 hours <b>[or in accordance with the Risk Informed Completion Time Program]</b> from discovery of two divisions with no offsite power</p> <p><u>IOR</u></p> <p><del>In accordance with the Risk Informed Completion Time Program]</del></p> |
| B. One [required] DG inoperable. | <p>B.1 Perform SR 3.8.1.1 for OPERABLE [required] offsite circuit(s).</p> <p><u>AND</u></p>  | <p>1 hour</p> <p><u>AND</u></p> <p>Once per 8 hours thereafter</p>  |

## BASES

---

### ACTIONS (continued)

Divisions (e.g., any Division 1 ECCS and Division 2 ECCS) cannot be automatically initiated due to inoperable, untripped channels within the same variable as described in the paragraph above. For Required Action B.2, the Completion Time only begins upon discovery that the HPCS System cannot be automatically initiated due to two inoperable, untripped channels for the associated Function in the same trip system. The 1 hour Completion Time from discovery of loss of initiation capability is acceptable because it minimizes risk while allowing time for restoration or tripping of channels.

Because of the diversity of sensors available to provide initiation signals and the redundancy of the ECCS design, an allowable out of service time of 24 hours has been shown to be acceptable (Ref. 5) to permit restoration of any inoperable channel to OPERABLE status.

[Alternatively, a Completion Time can be determined in accordance with the Risk Informed Completion Time Program.] If the inoperable channel cannot be restored to OPERABLE status within the allowable out of service time, the channel must be placed in the tripped condition per Required Action B.3. Placing the inoperable channel in trip would conservatively compensate for the inoperability, restore capability to accommodate a single failure, and allow operation to continue. Alternately, if it is not desired to place the channel in trip (e.g., as in the case where placing the inoperable channel in trip would result in an initiation), Condition **IH** must be entered and its Required Action taken.

#### C.1 and C.2

Required Action C.1 is intended to ensure that appropriate actions are taken if multiple, inoperable channels within the same Function (or in some cases, within the same variable) result in redundant automatic initiation capability being lost for the feature(s). Required Action C.1 features would be those that are initiated by Functions 1.c, 1.d, 2.c, and 2.d (i.e., low pressure ECCS). For Functions 1.c and 2.c, redundant automatic initiation capability is lost if the Function 1.c and Function 2.c channels are inoperable. For Functions 1.d and 2.d, redundant automatic initiation capability is lost if two Function 1.d channels in the same trip system and two Function 2.d channels in the same trip system (but not necessarily the same trip system as the Function 1.d channels) are inoperable. Since each inoperable channel would have Required Action C.1 applied separately (refer to ACTIONS Note), each inoperable channel would only require the affected portion of the associated Division to be declared inoperable. However, since channels in both Divisions are inoperable, and the Completion Times started concurrently for the channels in both Divisions, this results in the affected portions in both Divisions being concurrently declared inoperable. For Functions 1.c

## BASES

---

### ACTIONS (continued)

cannot be restored to OPERABLE status within the allowable out of service time, Condition ~~IH~~ must be entered and its Required Action taken. The Required Actions do not allow placing the channel in trip since this action would either cause the initiation or would not necessarily result in a safe state for the channel in all events.

#### D.1, D.2.1, and D.2.2

Required Action D.1 is intended to ensure that appropriate actions are taken if multiple, inoperable, untripped channels within the same Function result in a complete loss of automatic component initiation capability for the HPCS System. Automatic component initiation capability is lost if two Function 3.d channels or two Function 3.e channels are inoperable and untripped. In this situation (loss of automatic suction swap), the 24 hour allowance of Required Actions D.2.1 and D.2.2 is not appropriate and the HPCS System must be declared inoperable within 1 hour after discovery of loss of HPCS initiation capability. As noted, the Required Action is only applicable if the HPCS pump suction is not aligned to the suppression pool, since, if aligned, the Function is already performed.

The Completion Time is intended to allow the operator time to evaluate and repair any discovered inoperabilities. This Completion Time also allows for an exception to the normal "time zero" for beginning the allowed outage time "clock." For Required Action D.1, the Completion Time only begins upon discovery that the HPCS System cannot be automatically aligned to the suppression pool due to two inoperable, untripped channels in the same Function. The 1 hour Completion Time from discovery of loss of initiation capability is acceptable because it minimizes risk while allowing time for restoration or tripping of channels.

Because of the diversity of sensors available to provide initiation signals and the redundancy of the ECCS design, an allowable out of service time of 24 hours has been shown to be acceptable (Ref. 5) to permit restoration of any inoperable channel to OPERABLE status.

[Alternatively, a Completion Time can be determined in accordance with the Risk Informed Completion Time Program.] If the inoperable channel cannot be restored to OPERABLE status within the allowable out of service time, the channel must be placed in the tripped condition per Required Action D.2.1 or the suction source must be aligned to the suppression pool within 24 hours per Required Action D.2.2. Placing the inoperable channel in trip performs the intended function of the channel (shifting the suction source to the suppression pool). Performance of either of these two Required Actions will allow operation to continue. If Required Action D.2.1 or Required Action D.2.2 is performed, measures should be taken to ensure that the HPCS System piping remains filled

## BASES

---

### ACTIONS (continued)

with water. Alternately, if it is not desired to perform Required Actions D.2.1 and D.2.2 (e.g., as in the case where shifting the suction source could drain down the HPCS suction piping), Condition **IH** must be entered and its Required Action taken.

#### E.1 and E.2

Required Action E.1 is intended to ensure that appropriate actions are taken if multiple, inoperable, untripped channels within the LPCS and LPCI Pump Discharge Flow - Low (Bypass) Functions result in redundant automatic initiation capability being lost for the feature(s). For Required Action E.1, the features would be those that are initiated by Functions 1.e, 1.f, and 2.e (e.g., low pressure ECCS). Redundant automatic initiation capability is lost if three of the four channels associated with Functions 1.e, 1.f, and 2.e are inoperable. Since each inoperable channel would have Required Action E.1 applied separately (refer to ACTIONS Note), each inoperable channel would only require the affected low pressure ECCS pump to be declared inoperable. However, since channels for more than one low pressure ECCS pump are inoperable, and the Completion Times started concurrently for the channels of the low pressure ECCS pumps, this results in the affected low pressure ECCS pumps being concurrently declared inoperable.

In this situation (loss of redundant automatic initiation capability), the 7 day allowance of Required Action E.2 is not appropriate and the feature(s) associated with each inoperable channel must be declared inoperable within 1 hour after discovery of loss of initiation capability for feature(s) in both Divisions. A Note is also provided (the Note to Required Action E.1) to delineate that Required Action E.1 is only applicable to low pressure ECCS Functions. Required Action E.1 is not applicable to HPCS Functions 3.f and 3.g since the loss of one channel results in a loss of the Function (one-out-of-one logic). This loss was considered during the development of Reference 5 and considered acceptable for the 7 days allowed by Required Action E.2.

The Completion Time is intended to allow the operator time to evaluate and repair any discovered inoperabilities. This Completion Time also allows for an exception to the normal "time zero" for beginning the allowed outage time "clock." For Required Action E.1, the Completion Time only begins upon discovery that three channels of the variable

## BASES

---

### ACTIONS (continued)

(Pump Discharge Flow - Low) cannot be automatically initiated due to inoperable channels. The 1 hour Completion Time from discovery of loss of initiation capability is acceptable because it minimizes risk while allowing time for restoration of channels.

If the instrumentation that controls the pump minimum flow valve is inoperable such that the valve will not automatically open, extended pump operation with no injection path available could lead to pump overheating and failure. If there were a failure of the instrumentation such that the valve would not automatically close, a portion of the pump flow could be diverted from the reactor injection path, causing insufficient core cooling. These consequences can be averted by the operator's manual control of the valve, which would be adequate to maintain ECCS pump protection and required flow. Furthermore, other ECCS pumps would be sufficient to complete the assumed safety function if no additional single failure were to occur. The 7 day Completion Time of Required Action E.2 to restore the inoperable channel to OPERABLE status is reasonable based on the remaining capability of the associated ECCS subsystems, the redundancy available in the ECCS design, and the low probability of a DBA occurring during the allowed out of service time. If the inoperable channel cannot be restored to OPERABLE status within the allowable out of service time, Condition IH must be entered and its Required Action taken. The Required Actions do not allow placing the channel in trip since this action would not necessarily result in a safe state for the channel in all events. [Alternatively, a Completion Time can be determined in accordance with the Risk Informed Completion Time Program.]

#### F.1 and F.2

Required Action F.1 is intended to ensure that appropriate actions are taken if multiple, inoperable, untripped channels within similar ADS trip system Functions result in automatic initiation capability being lost for the ADS. Automatic initiation capability is lost if either (a) more than one Function 4.a channel and one Function 5.a channel are inoperable and untripped, (b) one Function 4.b channel and one Function 5.b channel are inoperable and untripped, or (c) one Function 4.d channel and one Function 5.d channel are inoperable and untripped.

In this situation (loss of automatic initiation capability), the 96 hour or 8 day allowance, as applicable, of Required Action F.2 is not appropriate, and all ADS valves must be declared inoperable within 1 hour after discovery of loss of ADS initiation capability in both trip systems.

## BASES

## ACTIONS (continued)

The Completion Time is intended to allow the operator time to evaluate and repair any discovered inoperabilities. This Completion Time also allows for an exception to the normal "time zero" for beginning the allowed outage time "clock." For Required Action F.1, the Completion Time only begins upon discovery that the ADS cannot be automatically initiated due to inoperable, untripped channels within similar ADS trip system Functions as described in the paragraph above. The 1 hour Completion Time from discovery of loss of initiation capability is acceptable because it minimizes risk while allowing time for restoration or tripping of channels.

Because of the diversity of sensors available to provide initiation signals and the redundancy of the ECCS design, an allowable out of service time of 8 days has been shown to be acceptable (Ref. 5) to permit restoration of any inoperable channel to OPERABLE status if both HPCS and RCIC are OPERABLE. [Alternatively, a Completion Time can be determined in accordance with the Risk Informed Completion Time Program.] If either HPCS or RCIC is inoperable, the time is shortened to 96 hours. [Alternatively, a Completion Time can be determined in accordance with the Risk Informed Completion Time Program.] If the status of HPCS or RCIC changes such that the Completion Time changes from 8 days to 96 hours, the 96 hours begins upon discovery of HPCS or RCIC inoperability. However, total time for an inoperable, untripped channel cannot exceed 8 days. If the status of HPCS or RCIC changes such that the Completion Time changes from 96 hours to 8 days, the "time zero" for beginning the 8 day "clock" begins upon discovery of the inoperable, untripped channel. If the inoperable channel cannot be restored to OPERABLE status within the allowable out of service time, the channel must be placed in the tripped condition per Required Action F.2. Placing the inoperable channel in trip would conservatively compensate for the inoperability, restore capability to accommodate a single failure, and allow operation to continue. Alternately, if it is not desired to place the channel in trip (e.g., as in the case where placing the inoperable channel in trip would result in an initiation), Condition **IH** must be entered and its Required Action taken.

G.1 and G.2

Required Action G.1 is intended to ensure that appropriate actions are taken if ~~multiple, inoperable channels within similar ADS trip system Functions result in automatic initiation capability being lost for the ADS. Automatic initiation capability is lost if either~~ (a) one Function 4.c channel and one Function 5.c channel are inoperable, ~~(b) one or more channels Functions 4.e channels and one or more Function 5.e channels are~~

## BASES

## ACTIONS (continued)

~~inoperable, (c) one or more Function 4.f channels and one or more Function 5.e channels are inoperable,~~ or (bd) one or more Function 4.g channels and one or more Function 5.f channels are inoperable.

In this situation (loss of automatic initiation capability), the 96 hour or 8 day allowance, as applicable, of Required Action G.2 is not appropriate, and all ADS valves must be declared inoperable within 1 hour after discovery of loss of ADS initiation capability in both trip systems. ~~The Note to Required Action G.1 states that Required Action G.1 is only applicable for Functions 4.c, 4.e, 4.f, 4.g, 5.c, 5.e, and 5.f. Required Action G.1 is not applicable to Functions 4.h and 5.g (which also require entry into this Condition if a channel in these Functions is inoperable), since they are the Manual Initiation Functions and are not assumed in any accident or transient analysis. Thus, a total loss of manual initiation capability for 96 hours or 8 days (as allowed by Required Action G.2) is allowed.~~

The Completion Time is intended to allow the operator time to evaluate and repair any discovered inoperabilities. This Completion Time also allows for an exception to the normal "time zero" for beginning the allowed outage time "clock." For Required Action G.1, the Completion Time only begins upon discovery that the ADS cannot be automatically initiated due to inoperable channels within similar ADS trip system Functions, as described in the paragraph above. The 1 hour Completion Time from discovery of loss of initiation capability is acceptable because it minimizes risk while allowing time for restoration ~~or tripping~~ of channels.

Because of the diversity of sensors available to provide initiation signals and the redundancy of the ECCS design, an allowable out of service time of 8 days has been shown to be acceptable (Ref. 5) to permit restoration to OPERABLE status if both HPCS and RCIC are OPERABLE (Required Action G.2). [Alternatively, a Completion Time can be determined in accordance with the Risk Informed Completion Time Program.] If either HPCS or RCIC is inoperable, the time is reduced to 96 hours. [Alternatively, a Completion Time can be determined in accordance with the Risk Informed Completion Time Program.] If the status of HPCS or RCIC changes such that the Completion Time changes from 8 days to 96 hours, the 96 hours begins upon discovery of HPCS or RCIC inoperability. However, total time for an inoperable channel cannot exceed 8 days. If the status of HPCS or RCIC changes such that the Completion Time changes from 96 hours to 8 days, the "time zero" for beginning the 8 day "clock" begins upon discovery of the inoperable channel. If the inoperable channel cannot be restored to OPERABLE status within the allowable out of service time, Condition ~~IH~~ must be

BASES

---

## ACTIONS (continued)

entered and its Required Action taken. The Required Actions do not allow placing the channel in trip since this action would not necessarily result in a safe state for the channel in all events.

**H.1, H.2, and H.3**

**Required Action H.1 requires that the ADS valves be declared inoperable when a combination of Functions 4.e, 4.f, and 5.e channels are inoperable such that neither ADS Trip System A or B has two Operable Discharge Pressure – High channels associated with one low pressure ECCS pump.**

**In this situation (loss of automatic initiation capability), the 96 hour or 8 day allowance, as applicable, of Required Action H.2 is not appropriate, and all ADS valves must be declared inoperable within 1 hour after discovery of loss of ADS initiation capability in both trip systems. The Notes to Required Action H.1 state that Required Action H.1 is only applicable for Functions 4.e, 4.f, and 5.e, and that it is only applicable when ADS Trip Systems A and B are inoperable due to LPCS/LPCI Discharge Pressure – High channels being inoperable. Required Action H.1 is not applicable to Functions 4.h and 5.g (which also require entry into this Condition if a channel in these Functions is inoperable), since they are the Manual Initiation Functions and are not assumed in any accident or transient analysis. Thus, a total loss of these functions for 30 days (as allowed by Required Action H.3) is allowed.**

**The Completion Time is intended to allow the operator time to evaluate and repair any discovered inoperabilities. This Completion Time also allows for an exception to the normal "time zero" for beginning the allowed outage time "clock." For Required Action H.1, the Completion Time only begins upon discovery that the ADS cannot be automatically initiated due to inoperable channels within similar ADS trip system Functions, as described in the paragraph above. The 1 hour Completion Time from discovery of loss of initiation capability is acceptable because it minimizes risk while allowing time for restoration or tripping of channels. If the inoperable channels cannot be restored to OPERABLE status within the allowable out of service time, Condition I must be entered and its Required Action taken.**

## BASES

## ACTIONS (continued)

Required Action H.2 is intended to ensure that appropriate actions are taken if there are not two Operable Discharge Pressure – High channels associated with one low pressure ECCS pump within one ADS trip system, which results in automatic initiation capability being lost for that ADS trip system. Because of the diversity of sensors available to provide initiation signals and the redundancy of the ECCS design, an allowable out of service time of 8 days has been shown to be acceptable (Ref. 5) to permit restoration of two inoperable Discharge Pressure – High channels associated with one low pressure ECCS Pump to OPERABLE status if both HPCS and RCIC are OPERABLE (Required Action H.2). [Alternatively, a Completion Time can be determined in accordance with the Risk Informed Completion Time Program.] If either HPCS or RCIC is inoperable, the time is reduced to 96 hours. [Alternatively, a Completion Time can be determined in accordance with the Risk Informed Completion Time Program.] If the status of HPCS or RCIC changes such that the Completion Time changes from 8 days to 96 hours, the 96 hours begins upon discovery of HPCS or RCIC inoperability. However, the total time to restore the required inoperable channels to OPERABLE status cannot exceed 8 days. If the status of HPCS or RCIC changes such that the Completion Time changes from 96 hours to 8 days, the "time zero" for beginning the 8 day "clock" begins upon discovery of the inoperable channel. If the minimum required inoperable channels cannot be restored to OPERABLE status within the allowable out of service time, Condition I must be entered and its Required Action taken. The Required Actions do not allow placing the channel in trip since this action would not necessarily result in a safe state for the channel in all events. The Notes to Required Action H.2 state that Required Action H.2 is only applicable for Functions 4.e, 4.f, and 5.e, and that it is only applicable when one ADS trip system is inoperable due to LPCS/LPCI Discharge Pressure – High functions being inoperable. Required Action H.2 is not applicable to Functions 4.h and 5.g (which also require entry into this Condition if a channel in these Functions is inoperable), since they are the Manual Initiation Functions and are not assumed in any accident or transient analysis. Thus, a total loss of these functions for 30 days (as allowed by Required Action H.3) is allowed.

Required Action H.3 is intended to ensure that appropriate actions are taken if inoperable channels within one ADS trip system do not result in loss of automatic initiation capability to respond to a design basis event, but require restoration per Table 3.3.5.1-1. This applies to Functions 4.e, 4.f, 4.h, 5.e, and 5.g. The 30 day Completion Time of Required Action H.3 is acceptable, based on operating experience, considering the multiple channels available for meeting

**the low pressure ECCS discharge pressure permissive, and the availability of automatic ADS initiation. If the inoperable channel cannot be restored to OPERABLE status within the allowable out of service time, Condition I must be entered and its Required Action taken.**

#### IH.1

With any Required Action and associated Completion Time not met, the associated feature(s) (**LPCS, LPCI, HPCS, or ADS**) may be incapable of performing the intended function and the supported feature(s) associated with the inoperable untripped channels must be declared inoperable immediately.

---

#### SURVEILLANCE REQUIREMENTS

-----REVIEWER'S NOTE-----  
Certain Frequencies are based on approved topical reports. In order for a licensee to use these Frequencies, the licensee must justify the Frequencies as required by the staff SER for the topical report.  
-----

-----REVIEWER'S NOTE-----  
Notes b and c are applied to the setpoint verification Surveillances for each ECCS Instrumentation Functions in Table 3.3.5.1-1 unless one or more of the following exclusions apply:

1. Manual actuation circuits, automatic actuation logic circuits or instrument functions that derive input from contacts which have no associated sensor or adjustable device, e.g., limit switches, breaker position switches, manual actuation switches, float switches, proximity detectors, etc. are excluded. In addition, those permissives and interlocks that derive input from a sensor or adjustable device that is tested as part of another TS function are excluded.
2. Settings associated with safety relief valves are excluded. The performance of these components is already controlled (i.e., trended with as-left and as-found limits) under the ASME Code for Operation and Maintenance of Nuclear Power Plants testing program.
3. Functions and Surveillance Requirements which test only digital components are normally excluded. There is no expected change in result between SR performances for these components. Where separate as-left and as-found tolerance is established for digital component SRs, the requirements would apply.

A generic evaluation of ECCS Instrumentation Functions resulted in Notes e and f being applied to the Functions shown in TS 3.3.5.1. Each licensee adopting this change must review the list of potential Functions to identify whether any of the identified functions meet any of the