

Security-Related Information Withheld under 10 CFR 2.390



Security-Related Information Withheld under 10 CFR 2.390

Security-Related Information Withheld under 10 CFR 2.390

Security-Related Information Withheld under 10 CFR 2.390

Security-Related Information Withheld under 10 CFR 2.390

Security-Related Information Withheld under 10 CFR 2.390

Security-Related Information Withheld under 10 CFR 2.390

Security-Related Information Withheld under 10 CFR 2.390

Security-Related Information Withheld under 10 CFR 2.390

# Security-Related Information Withheld under 10 CFR 2.390

Security-Related Information Withheld under 10 CFR 2.390

Security-Related Information Withheld under 10 CFR 2.390

Security-Related Information Withheld under 10 CFR 2.390

Figure A10.6a

Deleted

Figure A10.12 thru A.10.13

Deleted

Security-Related Information Withheld under 10 CFR 2.390

Security-Related Information Withheld under 10 CFR 2.390

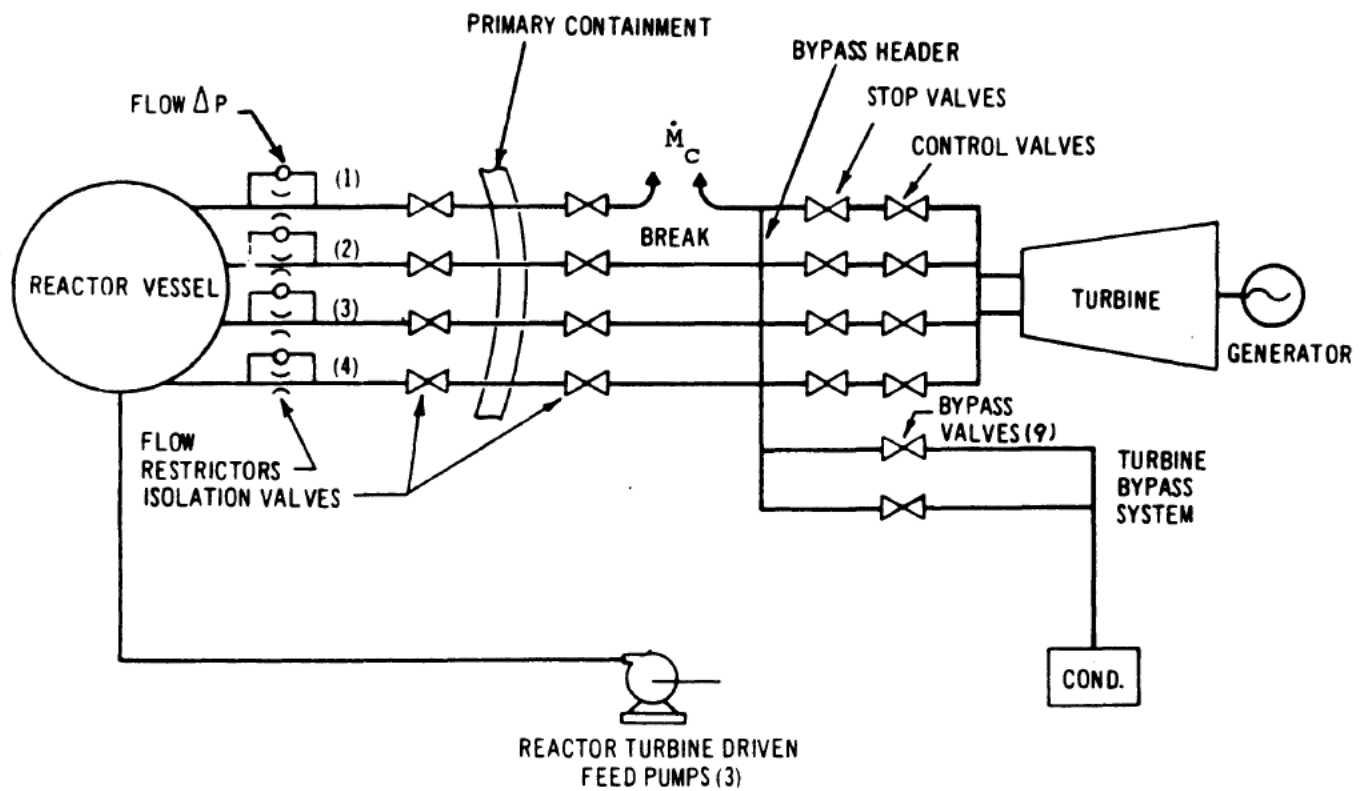

**PHILADELPHIA ELECTRIC COMPANY  
PEACH BOTTOM ATOMIC POWER STATION  
UNITS 2 AND 3  
UPDATED FINAL SAFETY ANALYSIS REPORT**

**CIRCUMFERENTIAL FAILURE MODEL  
MAIN STEAM SYSTEM**

**FIGURE A.10.16**

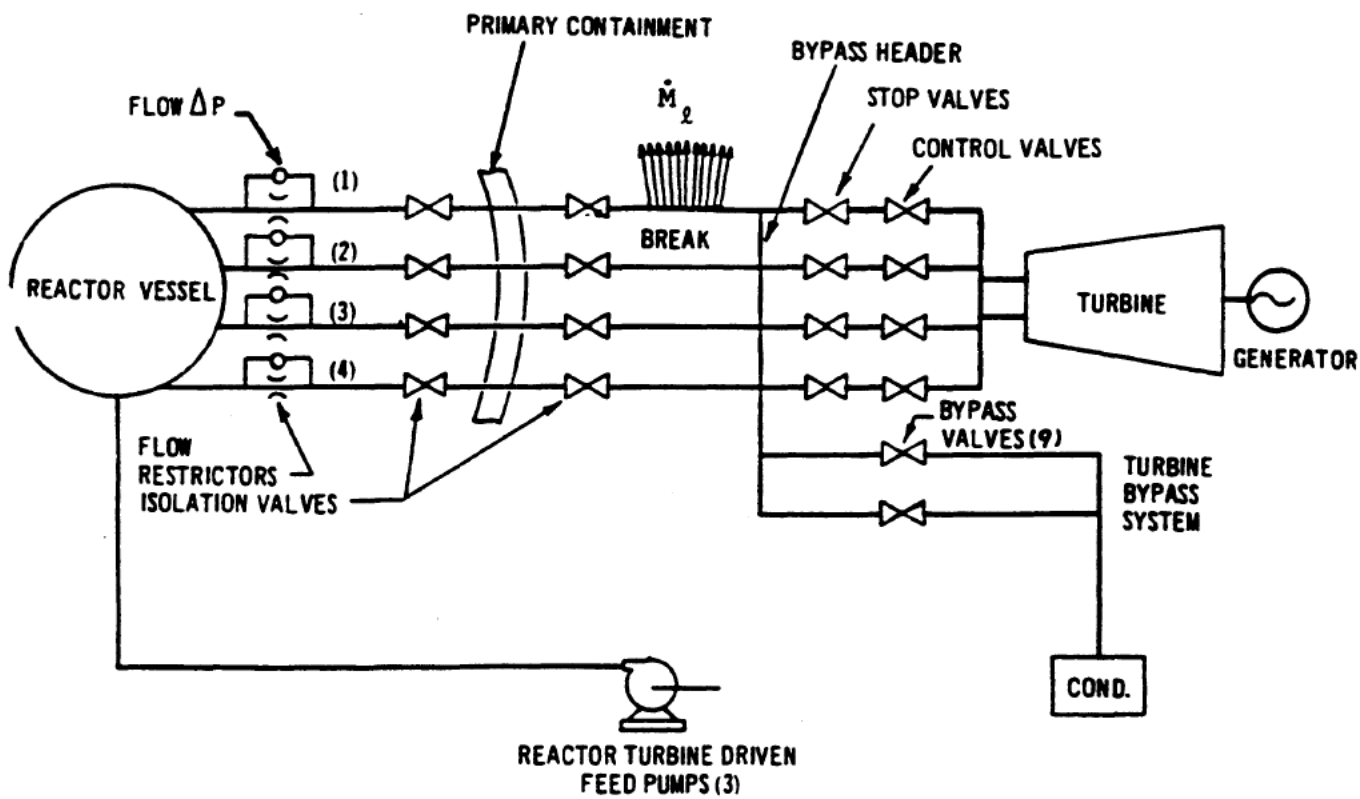

PECO ENERGY COMPANY  
 PEACH BOTTOM ATOMIC POWER STATION  
 UNITS 2 AND 3  
 UPDATED FINAL SAFETY ANALYSIS REPORT

FULL AREA LONGITUDINAL BREAK MODEL  
 MAIN STEAM SYSTEM

FIGURE A.10.17 Rev. 15 04/98