

RENEWED CERTIFICATE OF COMPLIANCE NO. 1014

APPENDIX B-100U

APPROVED CONTENTS AND DESIGN FEATURES

**FOR THE HI-STORM 100 CASK SYSTEM
(MODEL NO. 100U ADDITION)**

AMENDMENT NO. 10

TABLE OF CONTENTS

1.0	DEFINITIONS.....	1-1
2.0	APPROVED CONTENTS.....	2-1
2.1	Fuel Specifications and Loading Conditions.....	2-1
2.2	Violations.....	2-2
2.3	Not Used.....	2-2
2.4	Decay Heat, Burnup, and Cooling Time Limits for ZR-Clad Fuel.....	2-25
3.0	DESIGN FEATURES.....	3-1
3.1	Site.....	3-1
3.2	Design Features Important for Criticality Control.....	3-1
3.3	Codes and Standards.....	3-2
3.4	Site Specific Parameters and Analyses.....	3-7
3.5	Not Used.....	3-10
3.6	Forced Helium Dehydration System.....	3-11
3.7	Deleted.....	3-13
3.8	Combustible Gas Monitoring During MPC Lid Welding and Cutting.....	3-14
3.9	Corrosion Mitigation Measures.....	3-15
3.10	Periodic Corrosion Inspections for Underground Systems.....	3-16
Table 3-1	Not Used.....	3-4
Table 3-2	Applicable Code Paragraphs for Underground VVMs.....	3-5
Table 3-3	Load Combinations for the Top Surface Pad, VVM Interface Pad, Support Foundation Pad, and the Retaining Wall Per ACI-318 (2005).....	3-8
Table 3-4	Values of Principal Design Parameters for the Underground ISFSI.....	3-8

1.0 Definitions

Refer to Appendix A for Definitions.

2.0 APPROVED CONTENTS

2.1 Fuel Specifications and Loading Conditions

2.1.1 Fuel To Be Stored In The HI-STORM SFSC System Model 100U

- a. INTACT FUEL ASSEMBLIES, and NON-FUEL HARDWARE meeting the limits specified in Table 2.1-1 and other referenced tables may be stored.
- b. For MPCs partially loaded with stainless steel clad fuel assemblies, all remaining fuel assemblies in the MPC shall meet the decay heat generation limit for the stainless steel clad fuel assemblies.
- c. For MPCs partially loaded with array/class 6x6A, 6x6B, 6x6C, 7x7A, or 8x8A fuel assemblies, all remaining ZR clad INTACT FUEL ASSEMBLIES in the MPC shall meet the decay heat generation limits for the 6x6A, 6x6B, 6x6C, 7x7A and 8x8A fuel assemblies.
- d. All BWR fuel assemblies may be stored with or without ZR channels with the exception of array/class 10x10D and 10x10E fuel assemblies, which may be stored with or without ZR or stainless steel channels.

2.1.2 Uniform Fuel Loading

Any authorized fuel assembly may be stored in any fuel storage location, subject to other restrictions related to NON-FUEL HARDWARE specified in the CoC.

(continued)

2.0 Approved Contents

2.1 Fuel Specifications and Loading Conditions (cont'd)

2.1.3 Regionalized Fuel Loading

Users may choose to store fuel using regionalized loading in lieu of uniform loading to allow higher heat emitting fuel assemblies to be stored than would otherwise be able to be stored using uniform loading. Regionalized loading is limited to those fuel assemblies with ZR cladding. Figures 2.1-1 through 2.1-4 define the regions for the MPC-24, MPC-24E, MPC-32, MPC-68 models, respectively¹. Fuel assembly burnup, decay heat, and cooling time limits for regionalized loading are specified in Section 2.4.2. Fuel assemblies used in regionalized loading shall meet all other applicable limits specified in Tables 2.1-1 through 2.1-3.

2.2 Violations


If any Fuel Specifications or Loading Conditions of 2.1 are violated, the following actions shall be completed:

- 2.2.1 The affected fuel assemblies shall be placed in a safe condition.
- 2.2.2 Within 24 hours, notify the NRC Operations Center.
- 2.2.3 Within 30 days, submit a special report which describes the cause of the violation, and actions taken to restore compliance and prevent recurrence.

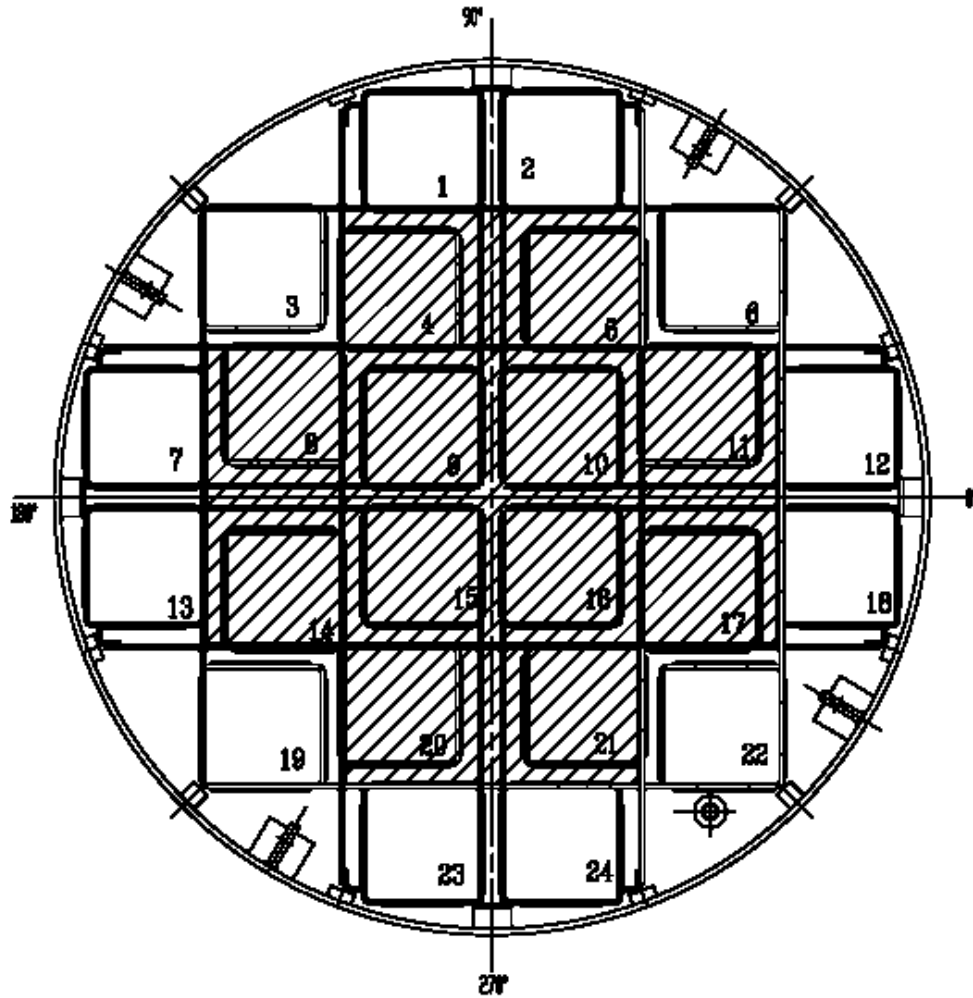
2.3 Not Used

¹ These figures are only intended to distinguish the fuel loading regions. Other details of the basket design are illustrative and may not reflect the actual basket design details. The design drawings should be consulted for basket design details.

LEGEND:


REGION 1: 

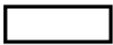
REGION 2: 

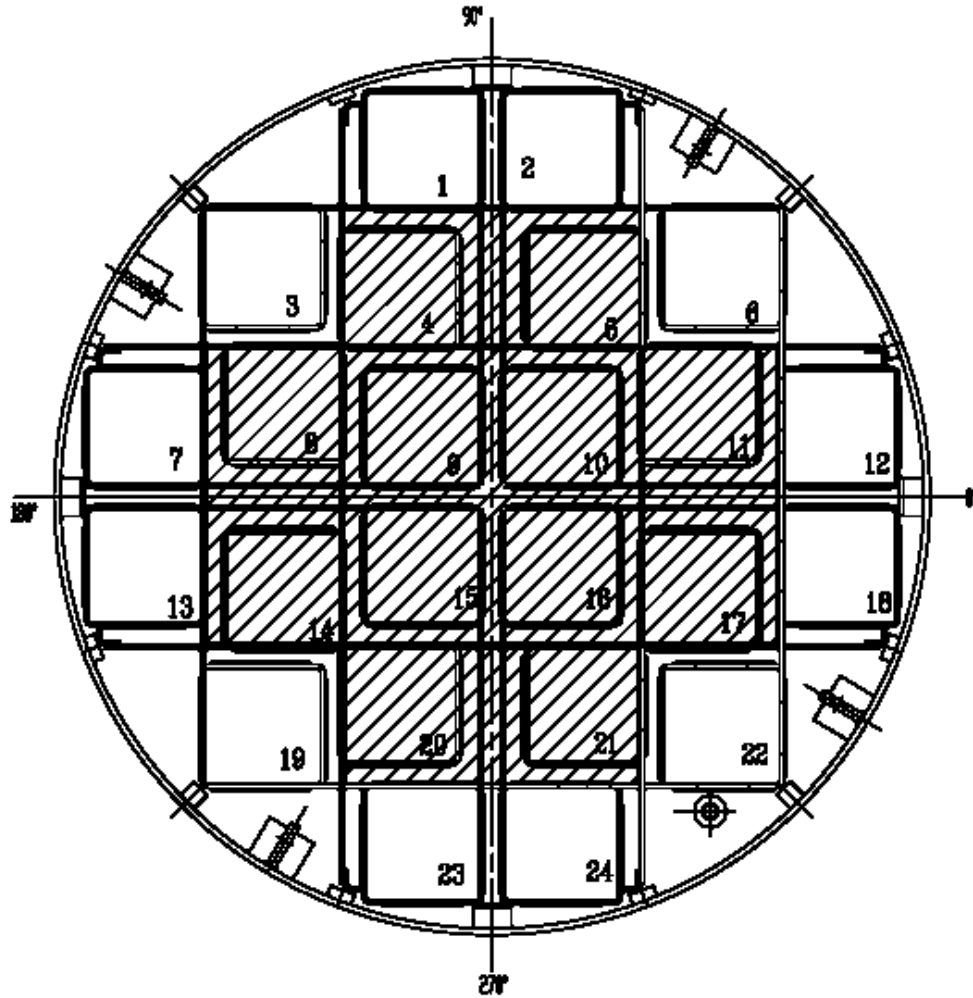


**Figure 2.1-1
Fuel Loading Regions - MPC-24**

LEGEND:


REGION 1: 

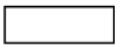
REGION 2: 

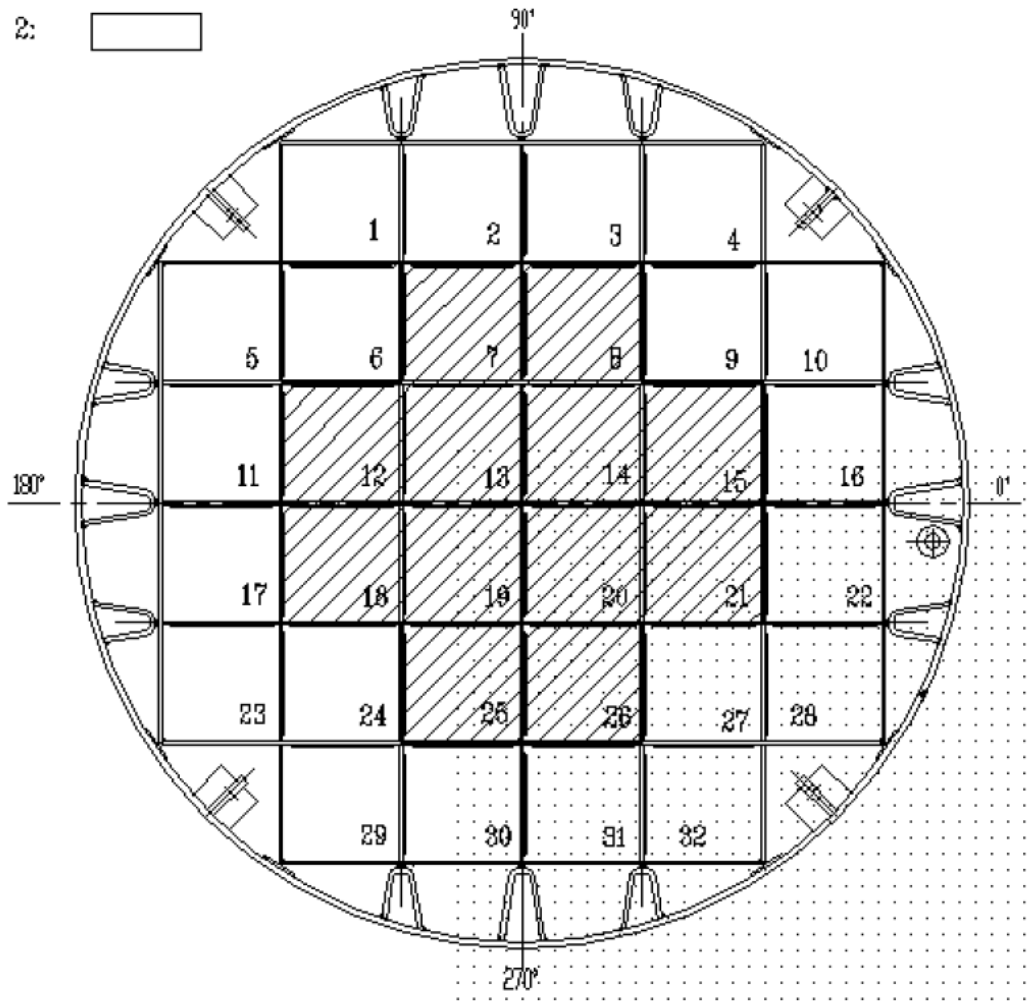


**Figure 2.1-2
Fuel Loading Regions - MPC-24E**

LEGEND:


REGION 1: 


REGION 2: 



**Figure 2.1-3
Fuel Loading Regions - MPC-32**

LEGEND:

REGION 1: 

REGION 2: 

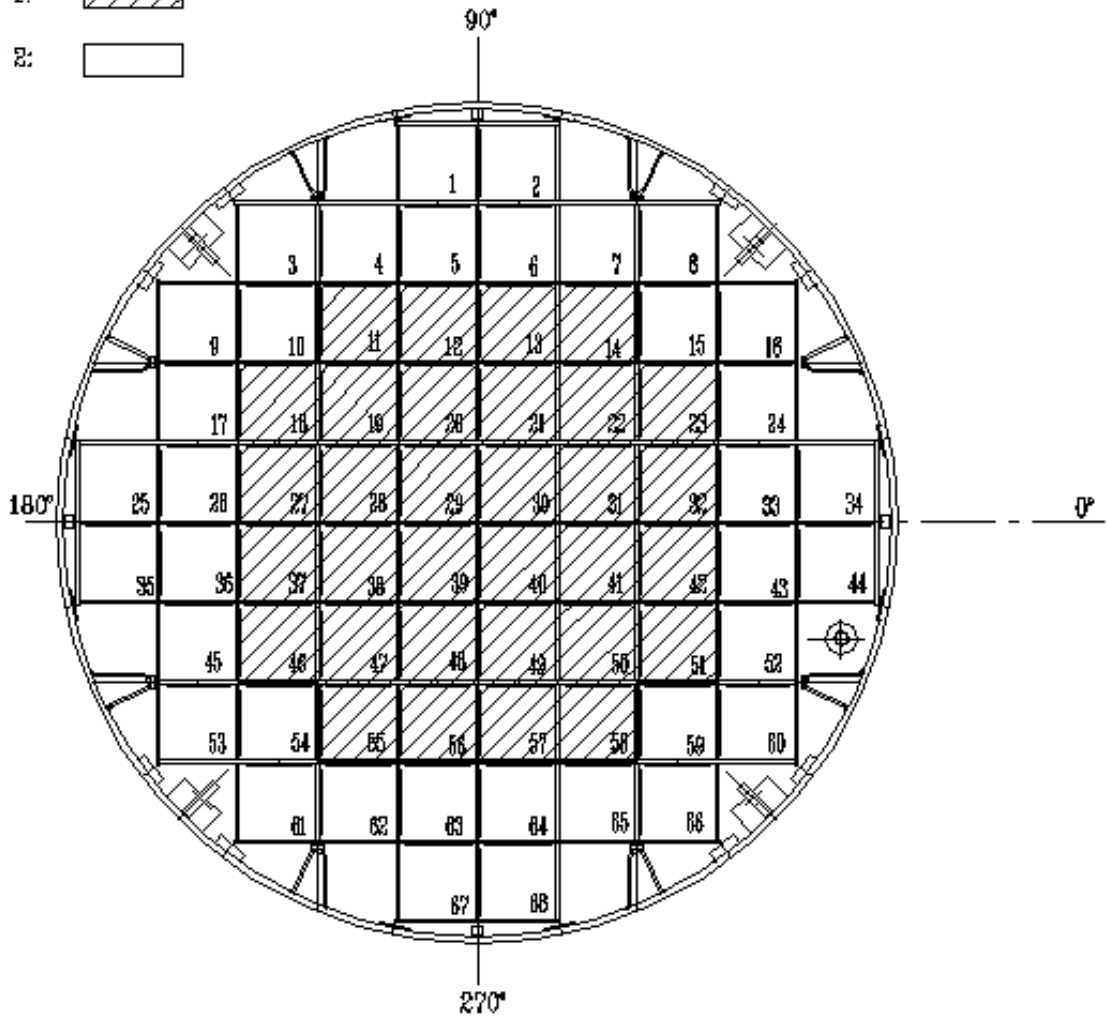


Figure 2.1-4
Fuel Loading Regions - MPC-68

Table 2.1-1 (page 1 of 8)
Fuel Assembly Limits

I. MPC MODEL: MPC-24

A. Allowable Contents

1. Uranium oxide, PWR INTACT FUEL ASSEMBLIES listed in Table 2.1-2, with or without NON-FUEL HARDWARE and meeting the following specifications (Note 1):

- a. Cladding Type: ZR or Stainless Steel (SS) as specified in Table 2.1-2 for the applicable fuel assembly array/class.
- b. Initial Enrichment: As specified in Table 2.1-2 for the applicable fuel assembly array/class.
- c. Post-irradiation Cooling Time and Average Burnup Per Assembly:
 - i. Array/Classes
14x14D, 14x14E, and
15x15G Cooling time \geq 8 years and an average burnup \leq 40,000 MWD/MTU.
 - ii. All Other Array/Classes Cooling time and average burnup as specified in Section 2.4.
 - ii. NON-FUEL HARDWARE As specified in Table 2.1-4.

Table 2.1-1 (page 2 of 8)
Fuel Assembly Limits

I. MPC MODEL: MPC-24 (continued)

A. Allowable Contents (continued)

d. Decay Heat Per Fuel Storage Location:

i. Array/Classes 14x14D, 14x14E, and 15x15G ≤ 710 Watts

ii. All Other Array/Classes As specified in Section 2.4.

e. Fuel Assembly Length: ≤ 176.8 inches (nominal design)

f. Fuel Assembly Width: ≤ 8.54 inches (nominal design)

g. Fuel Assembly Weight: ≤ 1720 lbs (including NON-FUEL HARDWARE) for assemblies that do not require fuel spacers, otherwise ≤ 1680 lbs (including NON-FUEL HARDWARE)

B. Quantity per MPC: Up to 24 fuel assemblies.

C. One NSA is authorized for loading into the MPC-24.

Note 1: Fuel assemblies containing BPRAs, TPDs, WABAs, water displacement guide tube plugs, orifice rod assemblies, or vibration suppressor inserts, with or without ITTRs, may be stored in any fuel storage location. Fuel assemblies containing APSRs or NSAs may only be loaded in fuel storage locations 9, 10, 15, and/or 16. Fuel assemblies containing CRAs, RCCAs, CEAs may only be stored in fuel storage locations 4, 5, 8 - 11, 14 - 17, 20 and/or 21 (see Figure 2.1-1). These requirements are in addition to any other requirements specified for uniform or regionalized fuel loading.

Table 2.1-1 (page 3 of 8)
Fuel Assembly Limits

II. MPC MODEL: MPC-68

A. Allowable Contents

1. Uranium oxide or MOX BWR INTACT FUEL ASSEMBLIES listed in Table 2.1-3, with or without channels and meeting the following specifications:

- | | |
|--|---|
| a. Cladding Type: | ZR or Stainless Steel (SS) as specified in Table 2.1-3 for the applicable fuel assembly array/class |
| b. Maximum PLANAR-AVERAGE INITIAL ENRICHMENT: | As specified in Table 2.1-3 for the applicable fuel assembly array/class. |
| c. Initial Maximum Rod Enrichment | As specified in Table 2.1-3 for the applicable fuel assembly array/class. |
| d. Post-irradiation Cooling Time and Average Burnup Per Assembly | |
| i. Array/Classes 6x6A, 6x6B, 6x6C, 7x7A, and 8x8A | Cooling time \geq 18 years and an average burnup \leq 30,000 MWD/MTU (or MWD/MTIHM). |
| ii. Array/Class 8x8F | Cooling time \geq 10 years and an average burnup \leq 27,500 MWD/MTU. |
| iii. Array/Classes 10x10D and 10x10E | Cooling time \geq 10 years and an average burnup \leq 22,500 MWD/MTU. |
| iv. All Other Array/Classes | As specified in Section 2.4. |

Table 2.1-1 (page 4 of 8)
Fuel Assembly Limits

II. MPC MODEL: MPC-68 (continued)

A. Allowable Contents (continued)

e. Decay Heat Per Assembly

- i. Array/Classes 6x6A, 6x6B, 6x6C, 7x7A, and 8x8A ≤ 115 Watts
- ii. Array/Class 8x8F ≤ 183.5 Watts
- iii. Array/Classes 10x10D and 10x10E ≤ 95 Watts
- iv. All Other Array/Classes As specified in Section 2.4.

f. Fuel Assembly Length

- i. Array/Class 6x6A, 6x6B, 6x6C, 7x7A, or 8x8A ≤ 135.0 inches (nominal design)
- ii. All Other Array/Classes ≤ 176.5 inches (nominal design)

g. Fuel Assembly Width

- i. Array/Class 6x6A, 6x6B, 6x6C, 7x7A, or 8x8A ≤ 4.70 inches (nominal design)
- ii. All Other Array/Classes ≤ 5.85 inches (nominal design)

h. Fuel Assembly Weight

- i. Array/Class 6x6A, 6x6B, 6x6C, 7x7A, or 8x8A ≤ 400 lbs, including channels
- ii. All Other Array/Classes ≤ 730 lbs, including channels

B. Quantity per MPC: Up to 68 fuel assemblies.

C. Dresden Unit 1 fuel assemblies with one Antimony-Beryllium neutron source are authorized for loading. The Antimony-Beryllium source material shall be in a water rod location.

D. Array/Class 10x10D and 10x10E fuel assemblies in stainless steel channels must be stored in fuel storage locations 19 - 22, 28 - 31, 38 -41, and/or 47 - 50 (see Figure 2.1-4).

Table 2.1-1 (page 5 of 8)
Fuel Assembly Limits

III. MPC MODEL: MPC-24E

A. Allowable Contents

1. Uranium oxide, PWR INTACT FUEL ASSEMBLIES listed in Table 2.1-2, with or without NON-FUEL HARDWARE and meeting the following specifications (Note 1):

- | | |
|---|---|
| a. Cladding Type: | ZR or Stainless Steel (SS) as specified in Table 2.1-2 for the applicable fuel assembly array/class |
| b. Initial Enrichment: | As specified in Table 2.1-2 for the applicable fuel assembly array/class. |
| c. Post-irradiation Cooling Time and Average Burnup Per Assembly: | |
| i. Array/Classes 14x14D, 14x14E, and 15x15G | Cooling time \geq 8 years and an average burnup \leq 40,000 MWD/MTU. |
| ii. All Other Array/Classes | As specified in Section 2.4. |
| iii. NON-FUEL HARDWARE | As specified in Table 2.1-4. |

Table 2.1-1 (page 6 of 8)
Fuel Assembly Limits

III. MPC MODEL: MPC-24E (continued)

A. Allowable Contents (continued)

d. Decay Heat Per Fuel Storage Location:

i. Array/Classes 14x14D, 14x14E, and 15x15G ≤ 710 Watts.

ii. All other Array/Classes As specified in Section 2.4.

e. Fuel Assembly Length: ≤ 176.8 inches (nominal design)

f. Fuel Assembly Width: ≤ 8.54 inches (nominal design)

g. Fuel Assembly Weight: $\leq 1,720$ lbs (including NON-FUEL HARDWARE) for assemblies that do not require fuel spacers, otherwise, $\leq 1,680$ lbs (including NON-FUEL HARDWARE)

B. Quantity per MPC: Up to 24 fuel assemblies.

C. One NSA is permitted for loading.

Note 1: Fuel assemblies containing BPRAs, TPDs, WABAs, water displacement guide tube plugs, orifice rod assemblies, or vibration suppressor inserts, with or without ITTRs, may be stored in any fuel storage location. Fuel assemblies containing APSRs or NSAs may only be loaded in fuel storage locations 9, 10, 15, and/or 16 (see Figure 2.1-2). Fuel assemblies containing CRAs, RCCAs, or CEAs may only be stored in fuel storage locations 4, 5, 8 - 11, 14 - 17, 20 and/or 21 (see Figure 2.1-2). These requirements are in addition to any other requirements specified for uniform or regionalized fuel loading.

Table 2.1-1 (page 7 of 8)
Fuel Assembly Limits

IV. MPC MODEL: MPC-32

A. Allowable Contents

1. Uranium oxide, PWR INTACT FUEL ASSEMBLIES listed in Table 2.1-2, with or without NON-FUEL HARDWARE and meeting the following specifications (Note 1):

- | | |
|---|--|
| a. Cladding Type: | ZR or Stainless Steel (SS) as specified in Table 2.1-2 for the applicable fuel assembly array/class |
| b. Initial Enrichment: | As specified in Table 2.1-2 for the applicable fuel assembly array/class. |
| c. Post-irradiation Cooling Time and Average Burnup Per Assembly: | |
| i. Array/Classes 14x14D, 14x14E, and 15x15G | Cooling time \geq 9 years and an average burnup \leq 30,000 MWD/MTU or cooling time \geq 20 years and an average burnup \leq 40,000 MWD/MTU. |
| ii. All Other Array/Classes | As specified in Section 2.4. |
| iii. NON-FUEL HARDWARE | As specified in Table 2.1-4. |

Table 2.1-1 (page 8 of 8)
Fuel Assembly Limits

IV. MPC MODEL: MPC-32 (continued)

A. Allowable Contents (continued)

d. Decay Heat Per Fuel Storage Location:

i. Array/Classes 14x14D, 14x14E, and 15x15G ≤ 500 Watts.

ii. All Other Array/Classes As specified in Section 2.4.

e. Fuel Assembly Length ≤ 176.8 inches (nominal design)

f. Fuel Assembly Width ≤ 8.54 inches (nominal design)

g. Fuel Assembly Weight $\leq 1,720$ lbs (including NON-FUEL HARDWARE) for assemblies that do not require fuel spacers, otherwise, $\leq 1,680$ lbs (including NON-FUEL HARDWARE)

B. Quantity per MPC: Up to 32 fuel assemblies.

C. One NSA is permitted for loading.

Note 1: Fuel assemblies containing BPRAs, TPDs, WABAs, water displacement guide tube plugs, orifice rod assemblies, or vibration suppressor inserts, with or without ITTRs, may be stored in any fuel storage location. Fuel assemblies containing NSAs may only be loaded in fuel storage locations 13, 14, 19 and/or 20 (see Figure 2.1-3). Fuel assemblies containing CRAs, RCCAs, CEAs or APSRs may only be loaded in fuel storage locations 7, 8, 12-15, 18-21, 25 and/or 26 (see Figure 2.1-3). These requirements are in addition to any other requirements specified for uniform or regionalized fuel loading.

Table 2.1-2 (page 1 of 5)
PWR FUEL ASSEMBLY CHARACTERISTICS (Note 1)

Fuel Assembly Array/Class	14x14A	14x14B	14x14C	14x14D	14x14E
Clad Material	ZR	ZR	ZR	SS	SS
Design Initial U (kg/assy.) (Note 3)	≤ 365	≤ 412	≤ 438	≤ 400	≤ 206
Initial Enrichment (MPC-24 and 24E without soluble boron credit) (wt % ²³⁵ U)	≤ 4.6 (24) ≤ 5.0 (24E)	≤ 4.6 (24) ≤ 5.0 (24E)	≤ 4.6 (24) ≤ 5.0 (24E)	≤ 4.0 (24) ≤ 5.0 (24E)	≤ 5.0 (24) ≤ 5.0 (24E)
Initial Enrichment (MPC-24, 24E, or 32, with soluble boron credit - see Note 5) (wt % ²³⁵ U)	≤ 5.0	≤ 5.0	≤ 5.0	≤ 5.0	≤ 5.0
No. of Fuel Rod Locations	179	179	176	180	173
Fuel Rod Clad O.D. (in.)	≥ 0.400	≥ 0.417	≥ 0.440	≥ 0.422	≥ 0.3415
Fuel Rod Clad I.D. (in.)	≤ 0.3514	≤ 0.3734	≤ 0.3880	≤ 0.3890	≤ 0.3175
Fuel Pellet Dia. (in.)(Note 7)	≤ 0.3444	≤ 0.3659	≤ 0.3805	≤ 0.3835	≤ 0.3130
Fuel Rod Pitch (in.)	≤ 0.556	≤ 0.556	≤ 0.580	≤ 0.556	Note 6
Active Fuel Length (in.)	≤ 150	≤ 150	≤ 150	≤ 144	≤ 102
No. of Guide and/or Instrument Tubes	17	17	5 (Note 4)	16	0
Guide/Instrument Tube Thickness (in.)	≥ 0.017	≥ 0.017	≥ 0.038	≥ 0.0145	N/A

Table 2.1-2 (page 2 of 5)
PWR FUEL ASSEMBLY CHARACTERISTICS (Note 1)

Fuel Assembly Array/Class	15x15A	15x15B	15x15C	15x15D	15x15E	15x15F
Clad Material	ZR	ZR	ZR	ZR	ZR	ZR
Design Initial U (kg/assy.) (Note 3)	≤ 473	≤ 473	≤ 473	≤ 495	≤ 495	≤ 495
Initial Enrichment (MPC-24 and 24E without soluble boron credit) (wt % ²³⁵ U)	≤ 4.1 (24)	≤ 4.1 (24)	≤ 4.1 (24)	≤ 4.1 (24)	≤ 4.1 (24)	≤ 4.1 (24)
	≤ 4.5 (24E)	≤ 4.5 (24E)	≤ 4.5 (24E)	≤ 4.5 (24E)	≤ 4.5 (24E)	≤ 4.5 (24E)
Initial Enrichment (MPC-24, 24E, or 32 with soluble boron credit - see Note 5)(wt % ²³⁵ U)	≤ 5.0	≤ 5.0	≤ 5.0	≤ 5.0	≤ 5.0	≤ 5.0
No. of Fuel Rod Locations	204	204	204	208	208	208
Fuel Rod Clad O.D. (in.)	≥ 0.418	≥ 0.420	≥ 0.417	≥ 0.430	≥ 0.428	≥ 0.428
Fuel Rod Clad I.D. (in.)	≤ 0.3660	≤ 0.3736	≤ 0.3640	≤ 0.3800	≤ 0.3790	≤ 0.3820
Fuel Pellet Dia. (in.) (Note 7)	≤ 0.3580	≤ 0.3671	≤ 0.3570	≤ 0.3735	≤ 0.3707	≤ 0.3742
Fuel Rod Pitch (in.)	≤ 0.550	≤ 0.563	≤ 0.563	≤ 0.568	≤ 0.568	≤ 0.568
Active Fuel Length (in.)	≤ 150	≤ 150	≤ 150	≤ 150	≤ 150	≤ 150
No. of Guide and/or Instrument Tubes	21	21	21	17	17	17
Guide/Instrument Tube Thickness (in.)	≥ 0.0165	≥ 0.015	≥ 0.0165	≥ 0.0150	≥ 0.0140	≥ 0.0140

Table 2.1-2 (page 3 of 5)
PWR FUEL ASSEMBLY CHARACTERISTICS (Note 1)

Fuel Assembly Array/ Class	15x15G	15x15H	16x16A	16x16B	16x16C
Clad Material	SS	ZR	ZR	ZR	ZR
Design Initial U (kg/assy.)(Note 3)	≤ 420	≤ 495	≤ 448	≤ 427	≤ 426
Initial Enrichment (MPC-24 and 24E without soluble boron credit) (wt % ²³⁵ U)	≤ 4.0 (24) ≤ 4.5 (24E)	≤ 3.8 (24) ≤ 4.2 (24E)	≤ 4.6 (24) ≤ 5.0 (24E)	≤ 4.6 (24) ≤ 5.0 (24E/24EF)	≤ 4.6 (24) ≤ 5.0 (24E/24EF)
Initial Enrichment (MPC-24, 24E, or 32 with soluble boron credit - see Note 5) (wt % ²³⁵ U)	≤ 5.0	≤ 5.0	≤ 5.0	≤ 5.0	≤ 5.0
No. of Fuel Rod Locations	204	208	236	236	235
Fuel Rod Clad O.D. (in.)	≥ 0.422	≥ 0.414	≥ 0.382	≥ 0.374	≥ 0.374
Fuel Rod Clad I.D. (in.)	≤ 0.3890	≤ 0.3700	≤ 0.3350	≤ 0.3290	≤ 0.3290
Fuel Pellet Dia. (in.) (Note 7)	≤ 0.3825	≤ 0.3622	≤ 0.3255	≤ 0.3225	≤ 0.3225
Fuel Rod Pitch (in.)	≤ 0.563	≤ 0.568	≤ 0.506	≤ 0.506	≤ 0.485
Active Fuel Length (in.)	≤ 144	≤ 150	≤ 150	≤ 150	≤ 150
No. of Guide and/or Instrument Tubes	21	17	5 (Note 4)	5 (Note 4)	21
Guide/Instrument Tube Thickness (in.)	≥ 0.0145	≥ 0.0140	≥ 0.0350	≥ 0.0400	≥ 0.0157

Table 2.1-2 (page 4 of 5)
PWR FUEL ASSEMBLY CHARACTERISTICS (Note 1)

Fuel Assembly Array/ Class	17x17A	17x17B	17x17C
Clad Material	ZR	ZR	ZR
Design Initial U (kg/assy.)(Note 3)	≤ 433	≤ 474	≤ 480
Initial Enrichment (MPC-24 and 24E without soluble boron credit) (wt % ²³⁵ U)	≤ 4.0 (24) ≤ 4.4 (24E)	≤ 4.0 (24) ≤ 4.4 (24E)	≤ 4.0 (24) ≤ 4.4 (24E)
Initial Enrichment (MPC-24, 24E, or 32 with soluble boron credit - see Note 5) (wt % ²³⁵ U)	≤ 5.0	≤ 5.0	≤ 5.0
No. of Fuel Rod Locations	264	264	264
Fuel Rod Clad O.D. (in.)	≥ 0.360	≥ 0.372	≥ 0.377
Fuel Rod Clad I.D. (in.)	≤ 0.3150	≤ 0.3310	≤ 0.3330
Fuel Pellet Dia. (in.) (Note 7)	≤ 0.3088	≤ 0.3232	≤ 0.3252
Fuel Rod Pitch (in.)	≤ 0.496	≤ 0.496	≤ 0.502
Active Fuel Length (in.)	≤ 150	≤ 150	≤ 150
No. of Guide and/or Instrument Tubes	25	25	25
Guide/Instrument Tube Thickness (in.)	≥ 0.016	≥ 0.014	≥ 0.020

Table 2.1-2 (page 5 of 5)
PWR FUEL ASSEMBLY CHARACTERISTICS

Notes:

1. All dimensions are design nominal values. Maximum and minimum dimensions are specified to bound variations in design nominal values among fuel assemblies within a given array/class.
2. Deleted.
3. Design initial uranium weight is the nominal uranium weight specified for each assembly by the fuel manufacturer or reactor user. For each PWR fuel assembly, the total uranium weight limit specified in this table may be increased up to 2.0 percent for comparison with users' fuel records to account for manufacturer's tolerances.
4. Each guide tube replaces four fuel rods.
5. Soluble boron concentration per LCO 3.3.1 of Appendix A-100U.
6. This fuel assembly array/class includes only the Indian Point Unit 1 fuel assembly. This fuel assembly has two pitches in different sectors of the assembly. These pitches are 0.441 inches and 0.453 inches.
7. Annular fuel pellets are allowed in the top and bottom 12" of the active fuel length.

Table 2.1-3 (page 1 of 5)
BWR FUEL ASSEMBLY CHARACTERISTICS (Note 1)

Fuel Assembly Array/Class	6x6A	6x6B	6x6C	7x7A	7x7B	8x8A
Clad Material	ZR	ZR	ZR	ZR	ZR	ZR
Design Initial U (kg/assy.) (Note 3)	≤ 110	≤ 110	≤ 110	≤ 100	≤ 198	≤ 120
Maximum PLANAR-AVERAGE INITIAL ENRICHMENT (wt.% ²³⁵ U)	≤ 2.7	≤ 2.7 for the UO ₂ rods. See Note 4 for MOX rods	≤ 2.7	≤ 2.7	≤ 4.2	≤ 2.7
Initial Maximum Rod Enrichment (wt.% ²³⁵ U)	≤ 4.0	≤ 4.0	≤ 4.0	≤ 5.5	≤ 5.0	≤ 4.0
No. of Fuel Rod Locations	35 or 36	35 or 36 (up to 9 MOX rods)	36	49	49	63 or 64
Fuel Rod Clad O.D. (in.)	≥ 0.5550	≥ 0.5625	≥ 0.5630	≥ 0.4860	≥ 0.5630	≥ 0.4120
Fuel Rod Clad I.D. (in.)	≤ 0.5105	≤ 0.4945	≤ 0.4990	≤ 0.4204	≤ 0.4990	≤ 0.3620
Fuel Pellet Dia. (in.)	≤ 0.4980	≤ 0.4820	≤ 0.4880	≤ 0.4110	≤ 0.4910	≤ 0.3580
Fuel Rod Pitch (in.)	≤ 0.710	≤ 0.710	≤ 0.740	≤ 0.631	≤ 0.738	≤ 0.523
Active Fuel Length (in.)	≤ 120	≤ 120	≤ 77.5	≤ 80	≤ 150	≤ 120
No. of Water Rods (Note 11)	1 or 0	1 or 0	0	0	0	1 or 0
Water Rod Thickness (in.)	> 0	> 0	N/A	N/A	N/A	≥ 0
Channel Thickness (in.)	≤ 0.060	≤ 0.060	≤ 0.060	≤ 0.060	≤ 0.120	≤ 0.100

Table 2.1-3 (2 of 5)
BWR FUEL ASSEMBLY CHARACTERISTICS (Note 1)

Fuel Assembly Array/Class	8x8B	8x8C	8x8D	8x8E	8x8F	9x9A
Clad Material	ZR	ZR	ZR	ZR	ZR	ZR
Design Initial U (kg/assy.) (Note 3)	≤ 192	≤ 190	≤ 190	< 190	≤ 191	≤ 180
Maximum PLANAR-AVERAGE INITIAL ENRICHMENT (wt.% ²³⁵ U)	≤ 4.2	≤ 4.2	≤ 4.2	≤ 4.2	≤ 4.0	≤ 4.2
Initial Maximum Rod Enrichment (wt.% ²³⁵ U)	≤ 5.0	≤ 5.0	≤ 5.0	≤ 5.0	≤ 5.0	≤ 5.0
No. of Fuel Rod Locations	63 or 64	62	60 or 61	59	64	74/66 (Note 5)
Fuel Rod Clad O.D. (in.)	≥ 0.4840	≥ 0.4830	≥ 0.4830	≥ 0.4930	≥ 0.4576	≥ 0.4400
Fuel Rod Clad I.D. (in.)	≤ 0.4295	≤ 0.4250	≤ 0.4230	≤ 0.4250	≤ 0.3996	≤ 0.3840
Fuel Pellet Dia. (in.)	≤ 0.4195	≤ 0.4160	≤ 0.4140	≤ 0.4160	≤ 0.3913	≤ 0.3760
Fuel Rod Pitch (in.)	≤ 0.642	≤ 0.641	≤ 0.640	≤ 0.640	≤ 0.609	≤ 0.566
Design Active Fuel Length (in.)	≤ 150	≤ 150	≤ 150	≤ 150	≤ 150	≤ 150
No. of Water Rods (Note 11)	1 or 0	2	1 - 4 (Note 7)	5	N/A (Note 12)	2
Water Rod Thickness (in.)	≥ 0.034	> 0.00	> 0.00	≥ 0.034	≥ 0.0315	> 0.00
Channel Thickness (in.)	≤ 0.120	≤ 0.120	≤ 0.120	≤ 0.100	≤ 0.055	≤ 0.120

Table 2.1-3 (page 3 of 5)
BWR FUEL ASSEMBLY CHARACTERISTICS (Note 1)

Fuel Assembly Array/Class	9x9B	9x9C	9x9D	9x9E (Note 13)	9x9F (Note 13)	9x9G
Clad Material	ZR	ZR	ZR	ZR	ZR	ZR
Design Initial U (kg/assy.)(Note 3)	≤ 180	≤ 182	≤ 182	≤ 183	≤ 183	≤ 164
Maximum PLANAR-AVERAGE INITIAL ENRICHMENT (wt.% ²³⁵ U)	≤ 4.2	≤ 4.2	≤ 4.2	≤ 4.0	≤ 4.0	≤ 4.2
Initial Maximum Rod Enrichment (wt.% ²³⁵ U)	≤ 5.0	≤ 5.0	≤ 5.0	≤ 5.0	≤ 5.0	≤ 5.0
No. of Fuel Rod Locations	72	80	79	76	76	72
Fuel Rod Clad O.D. (in.)	≥ 0.4330	≥ 0.4230	≥ 0.4240	≥ 0.4170	≥ 0.4430	≥ 0.4240
Fuel Rod Clad I.D. (in.)	≤ 0.3810	≤ 0.3640	≤ 0.3640	≤ 0.3640	≤ 0.3860	≤ 0.3640
Fuel Pellet Dia. (in.)	≤ 0.3740	≤ 0.3565	≤ 0.3565	≤ 0.3530	≤ 0.3745	≤ 0.3565
Fuel Rod Pitch (in.)	≤ 0.572	≤ 0.572	≤ 0.572	≤ 0.572	≤ 0.572	≤ 0.572
Design Active Fuel Length (in.)	≤ 150	≤ 150	≤ 150	≤ 150	≤ 150	≤ 150
No. of Water Rods (Note 11)	1 (Note 6)	1	2	5	5	1 (Note 6)
Water Rod Thickness (in.)	> 0.00	≥ 0.020	≥ 0.0300	≥ 0.0120	≥ 0.0120	≥ 0.0320
Channel Thickness (in.)	≤ 0.120	≤ 0.100	≤ 0.100	≤ 0.120	≤ 0.120	≤ 0.120

Table 2.1-3 (page 4 of 5)
BWR FUEL ASSEMBLY CHARACTERISTICS (Note 1)

Fuel Assembly Array/Class	10x10A	10x10B	10x10C	10x10D	10x10E
Clad Material	ZR	ZR	ZR	SS	SS
Design Initial U (kg/assy.) (Note 3)	≤ 188	≤ 188	≤ 179	≤ 125	≤ 125
Maximum PLANAR-AVERAGE INITIAL ENRICHMENT (wt.% ²³⁵ U)	≤ 4.2	≤ 4.2	≤ 4.2	≤ 4.0	≤ 4.0
Initial Maximum Rod Enrichment (wt.% ²³⁵ U)	≤ 5.0	≤ 5.0	≤ 5.0	≤ 5.0	≤ 5.0
No. of Fuel Rod Locations	92/78 (Note 8)	91/83 (Note 9)	96	100	96
Fuel Rod Clad O.D. (in.)	≥ 0.4040	≥ 0.3957	≥ 0.3780	≥ 0.3960	≥ 0.3940
Fuel Rod Clad I.D. (in.)	≤ 0.3520	≤ 0.3480	≤ 0.3294	≤ 0.3560	≤ 0.3500
Fuel Pellet Dia. (in.)	≤ 0.3455	≤ 0.3420	≤ 0.3224	≤ 0.3500	≤ 0.3430
Fuel Rod Pitch (in.)	≤ 0.510	≤ 0.510	≤ 0.488	≤ 0.565	≤ 0.557
Design Active Fuel Length (in.)	≤ 150	≤ 150	≤ 150	≤ 83	≤ 83
No. of Water Rods (Note 11)	2	1 (Note 6)	5 (Note 10)	0	4
Water Rod Thickness (in.)	≥ 0.0300	> 0.00	≥ 0.031	N/A	≥ 0.022
Channel Thickness (in.)	≤ 0.120	≤ 0.120	≤ 0.055	≤ 0.080	≤ 0.080

Table 2.1-3 (page 5 of 5)
BWR FUEL ASSEMBLY CHARACTERISTICS

Notes:

1. All dimensions are design nominal values. Maximum and minimum dimensions are specified to bound variations in design nominal values among fuel assemblies within a given array/class.
2. Not Used.
3. Design initial uranium weight is the nominal uranium weight specified for each assembly by the fuel manufacturer or reactor user. For each BWR fuel assembly, the total uranium weight limit specified in this table may be increased up to 1.5 percent for comparison with users' fuel records to account for manufacturer tolerances.
4. ≤ 0.635 wt. % ^{235}U and ≤ 1.578 wt. % total fissile plutonium (^{239}Pu and ^{241}Pu), (wt. % of total fuel weight, i.e., UO_2 plus PuO_2).
5. This assembly class contains 74 total rods; 66 full length rods and 8 partial length rods.
6. Square, replacing nine fuel rods.
7. Variable.
8. This assembly contains 92 total fuel rods; 78 full length rods and 14 partial length rods.
9. This assembly class contains 91 total fuel rods; 83 full length rods and 8 partial length rods.
10. One diamond-shaped water rod replacing the four center fuel rods and four rectangular water rods dividing the assembly into four quadrants.
11. These rods may also be sealed at both ends and contain Zr material in lieu of water.
12. This assembly is known as "QUAD+." It has four rectangular water cross segments dividing the assembly into four quadrants.
13. For the SPC 9x9-5 fuel assembly, each fuel rod must meet either the 9x9E or the 9x9F set of limits for clad O.D., clad I.D., and pellet diameter.

Table 2.1-4
NON-FUEL HARDWARE COOLING AND AVERAGE BURNUP (Notes 1, 2, 3, and 8)

Post-irradiation Cooling Time (years)	INSERTS (Note 4) BURNUP (MWD/MTU)	NSA or GUIDE TUBE HARDWARE (Note 5) BURNUP (MWD/MTU)	CONTROL COMPONENT (Note 6) BURNUP (MWD/MTU)	APSR BURNUP (MWD/MTU)
≥ 3	≤ 24,635	NA (Note 7)	NA	NA
≥ 4	≤ 30,000	≤ 20,000	NA	NA
≥ 5	≤ 36,748	≤ 25,000	≤ 630,000	≤ 45,000
≥ 6	≤ 44,102	≤ 30,000	-	≤ 54,500
≥ 7	≤ 52,900	≤ 40,000	-	≤ 68,000
≥ 8	≤ 60,000	≤ 45,000	-	≤ 83,000
≥ 9	-	≤ 50,000	-	≤ 111,000
≥ 10	-	≤ 60,000	-	≤ 180,000
≥ 11	-	≤ 75,000	-	≤ 630,000
≥ 12	-	≤ 90,000	-	-
≥ 13	-	≤ 180,000	-	-
≥ 14	-	≤ 630,000	-	-

- Notes:
1. Burnups for NON-FUEL HARDWARE are to be determined based on the burnup and uranium mass of the fuel assemblies in which the component was inserted during reactor operation.
 2. Linear interpolation between points is permitted, except that NSA or Guide Tube Hardware and APSR burnups > 180,000 MWD/MTU and ≤ 630,000 MWD/MTU must be cooled ≥ 14 years and ≥ 11 years, respectively.
 3. Applicable to uniform loading and regionalized loading.
 4. Includes Burnable Poison Rod Assemblies (BPRAs), Wet Annular Burnable Absorbers (WABAs), and vibration suppressor inserts.
 5. Includes Thimble Plug Devices (TPDs), water displacement guide tube plugs, and orifice rod assemblies.
 6. Includes Control Rod Assemblies (CRAs), Control Element Assemblies (CEAs), and Rod Cluster Control Assemblies (RCCAs).
 7. NA means not authorized for loading at this cooling time.
 8. Non-fuel hardware burnup and cooling times are not applicable to ITTRs since they are installed post irradiation.

2.4 Decay Heat, Burnup, and Cooling Time Limits for ZR-Clad Fuel

This section provides the limits on ZR-clad fuel assembly decay heat, burnup, and cooling time for storage in the HI-STORM 100 System Model 100U. The method to calculate the limits and verify compliance, including examples, is provided in Chapter 12 of the HI-STORM 100 FSAR.

2.4.1 Uniform Fuel Loading Decay Heat Limits for ZR-clad fuel

Table 2.4-1 provides the maximum allowable decay heat per fuel storage location for ZR-clad fuel in uniform fuel loading for each MPC model.

Table 2.4-1

Maximum Allowable Decay Heat per Fuel Storage Location
(Uniform Loading, ZR-Clad)

MPC Model	Decay Heat per Fuel Storage Location (kW)
	Intact Fuel Assemblies
MPC-24	≤ 1.266
MPC-24E	≤ 1.266
MPC-32	≤ 0.949
MPC-68	≤ 0.447

2.4.2 Regionalized Fuel Loading Decay Heat Limits for ZR-Clad Fuel (INTACT FUEL only)

The maximum allowable decay heat per fuel storage location for fuel in regionalized loading is determined using the following equations:

$$Q(X) = 2 \times \alpha \times Q_0 / (1 + X^y)$$

$$y = 0.23 / X^{0.1}$$

$$q_2 = Q(X) / (n_1 \times X + n_2)$$

$$q_1 = q_2 \times X$$

Where:

Q_0 = Maximum uniform storage MPC decay heat (34 kW)

α = Penalty Factor (0.894)

X = Inner region to outer region assembly decay heat ratio
($0.5 \leq X \leq 3$)

n_1 = Number of storage locations in inner region from Table 2.4-2.

n_2 = Number of storage locations in outer region from Table 2.4-2.

Table 2.4-2

Fuel Storage Regions per MPC

MPC Model	Number of Storage Locations in Inner Region (Region 1)	Number of Storage Locations in Outer Region (Region 2)
MPC-24 and MPC-24E	12	12
MPC-32	12	20
MPC-68	32	36

2.4.3 Burnup Limits as a Function of Cooling Time for ZR-Clad Fuel

The maximum allowable fuel assembly average burnup varies with the following parameters:

- § Minimum fuel assembly cooling time
- § Maximum fuel assembly decay heat
- § Minimum fuel assembly average enrichment

The maximum allowable ZR-clad fuel assembly average burnup for a given MINIMUM ENRICHMENT is calculated as described below for minimum cooling times between 3 and 20 years using the maximum permissible decay heat determined in Section 2.4.1 or 2.4.2. Different fuel assembly average burnup limits may be calculated for different minimum enrichments (by individual fuel assembly) for use in choosing the fuel assemblies to be loaded into a given MPC.

2.4.3.1 Choose a fuel assembly minimum enrichment, E_{235} .

2.4.3.2 Calculate the maximum allowable fuel assembly average burnup for a minimum cooling time between 3 and 20 years using the equation below.

$$Bu = (A \times q) + (B \times q^2) + (C \times q^3) + [D \times (E_{235})^2] + (E \times q \times E_{235}) + (F \times q^2 \times E_{235}) + G$$

Where:

Bu = Maximum allowable average burnup per fuel assembly
(MWD/MTU)

q = Maximum allowable decay heat per fuel storage location
determined in Section 2.4.1 or 2.4.2 (kW)

E_{235} = Minimum fuel assembly average enrichment (wt. % ^{235}U)
(e.g., for 4.05 wt.%, use 4.05)

A through G = Coefficients from Tables 2.4-3 and 2.4-4 for the
applicable fuel assembly array/class and
minimum cooling time

- 2.4.3.3 Calculated burnup limits shall be rounded down to the nearest integer.
- 2.4.3.4 Calculated burnup limits greater than 68,200 MWD/MTU for PWR fuel and 65,000 MWD/MTU for BWR must be reduced to be equal to these values.
- 2.4.3.5 Linear interpolation of calculated burnups between cooling times for a given fuel assembly maximum decay heat and minimum enrichment is permitted. For example, the allowable burnup for a cooling time of 4.5 years may be interpolated between those burnups calculated for 4 year and 5 years.
- 2.4.3.6 Each ZR-clad fuel assembly to be stored must have a MINIMUM ENRICHMENT greater than or equal to the value used in Step 2.4.3.2.
- 2.4.4 When complying with the maximum fuel storage location decay heat limits, users must account for the decay heat from both the fuel assembly and any NON-FUEL HARDWARE, as applicable for the particular fuel storage location, to ensure the decay heat emitted by all contents in a storage location does not exceed the limit.

Table 2.4-3 (Page 1 of 8)

PWR Fuel Assembly Cooling Time-Dependent Coefficients
(ZR-Clad Fuel)

Cooling Time (years)	Array/Class 14x14A						
	A	B	C	D	E	F	G
≥ 3	19311.5	275.367	-59.0252	-139.41	2851.12	-451.845	-615.413
≥ 4	33865.9	-5473.03	851.121	-132.739	3408.58	-656.479	-609.523
≥ 5	46686.2	-13226.9	2588.39	-150.149	3871.87	-806.533	-90.2065
≥ 6	56328.9	-20443.2	4547.38	-176.815	4299.19	-927.358	603.192
≥ 7	64136	-27137.5	6628.18	-200.933	4669.22	-1018.94	797.162
≥ 8	71744.1	-34290.3	9036.9	-214.249	4886.95	-1037.59	508.703
≥ 9	77262	-39724.2	11061	-228.2	5141.35	-1102.05	338.294
≥ 10	82939.8	-45575.6	13320.2	-233.691	5266.25	-1095.94	-73.3159
≥ 11	86541	-49289.6	14921.7	-242.092	5444.54	-1141.6	-83.0603
≥ 12	91383	-54456.7	17107	-242.881	5528.7	-1149.2	-547.579
≥ 13	95877.6	-59404.7	19268	-240.36	5524.35	-1094.72	-933.64
≥ 14	97648.3	-61091.6	20261.7	-244.234	5654.56	-1151.47	-749.836
≥ 15	102533	-66651.5	22799.7	-240.858	5647.05	-1120.32	-1293.34
≥ 16	106216	-70753.8	24830.1	-237.04	5647.63	-1099.12	-1583.89
≥ 17	109863	-75005	27038	-234.299	5652.45	-1080.98	-1862.07
≥ 18	111460	-76482.3	28076.5	-234.426	5703.52	-1104.39	-1695.77
≥ 19	114916	-80339.6	30126.5	-229.73	5663.21	-1065.48	-1941.83
≥ 20	119592	-86161.5	33258.2	-227.256	5700.49	-1100.21	-2474.01

Table 2.4-3 (Page 2 of 8)

PWR Fuel Assembly Cooling Time-Dependent Coefficients
(ZR-Clad Fuel)

Cooling Time (years)	Array/Class 14x14B						
	A	B	C	D	E	F	G
≥ 3	18036.1	63.7639	-24.7251	-130.732	2449.87	-347.748	-858.192
≥ 4	30303.4	-4304.2	598.79	-118.757	2853.18	-486.453	-459.902
≥ 5	40779.6	-9922.93	1722.83	-138.174	3255.69	-608.267	245.251
≥ 6	48806.7	-15248.9	3021.47	-158.69	3570.24	-689.876	833.917
≥ 7	55070.5	-19934.6	4325.62	-179.964	3870.33	-765.849	1203.89
≥ 8	60619.6	-24346	5649.29	-189.701	4042.23	-795.324	1158.12
≥ 9	64605.7	-27677.1	6778.12	-205.459	4292.35	-877.966	1169.88
≥ 10	69083.8	-31509.4	8072.42	-206.157	4358.01	-875.041	856.449
≥ 11	72663.2	-34663.9	9228.96	-209.199	4442.68	-889.512	671.567
≥ 12	74808.9	-36367	9948.88	-214.344	4571.29	-942.418	765.261
≥ 13	78340.3	-39541.1	11173.8	-212.8	4615.06	-957.833	410.807
≥ 14	81274.8	-42172.3	12259.9	-209.758	4626.13	-958.016	190.59
≥ 15	83961.4	-44624.5	13329.1	-207.697	4632.16	-952.876	20.8575
≥ 16	84968.5	-44982.1	13615.8	-207.171	4683.41	-992.162	247.54
≥ 17	87721.6	-47543.1	14781.4	-203.373	4674.3	-988.577	37.9689
≥ 18	90562.9	-50100.4	15940.4	-198.649	4651.64	-982.459	-247.421
≥ 19	93011.6	-52316.6	17049.9	-194.964	4644.76	-994.63	-413.021
≥ 20	95567.8	-54566.6	18124	-190.22	4593.92	-963.412	-551.983

Table 2.4-3 (Page 3 of 8)

PWR Fuel Assembly Cooling Time-Dependent Coefficients
(ZR-Clad Fuel)

Cooling Time (years)	Array/Class 14x14C						
	A	B	C	D	E	F	G
≥ 3	18263.7	174.161	-57.6694	-138.112	2539.74	-369.764	-1372.33
≥ 4	30514.5	-4291.52	562.37	-124.944	2869.17	-481.139	-889.883
≥ 5	41338	-10325.7	1752.96	-141.247	3146.48	-535.709	-248.078
≥ 6	48969.7	-15421.3	2966.33	-163.574	3429.74	-587.225	429.331
≥ 7	55384.6	-20228.9	4261.47	-180.846	3654.55	-617.255	599.251
≥ 8	60240.2	-24093.2	5418.86	-199.974	3893.72	-663.995	693.934
≥ 9	64729	-27745.7	6545.45	-205.385	3986.06	-650.124	512.528
≥ 10	68413.7	-30942.2	7651.29	-216.408	4174.71	-702.931	380.431
≥ 11	71870.6	-33906.7	8692.81	-218.813	4248.28	-704.458	160.645
≥ 12	74918.4	-36522	9660.01	-218.248	4283.68	-696.498	-29.0682
≥ 13	77348.3	-38613.7	10501.8	-220.644	4348.23	-702.266	-118.646
≥ 14	79817.1	-40661.8	11331.2	-218.711	4382.32	-710.578	-236.123
≥ 15	82354.2	-42858.3	12257.3	-215.835	4405.89	-718.805	-431.051
≥ 16	84787.2	-44994.5	13185.9	-213.386	4410.99	-711.437	-572.104
≥ 17	87084.6	-46866.1	14004.8	-206.788	4360.3	-679.542	-724.721
≥ 18	88083.1	-47387.1	14393.4	-208.681	4420.85	-709.311	-534.454
≥ 19	90783.6	-49760.6	15462.7	-203.649	4403.3	-705.741	-773.066
≥ 20	93212	-51753.3	16401.5	-197.232	4361.65	-692.925	-964.628

Table 2.4-3 (Page 4 of 8)

PWR Fuel Assembly Cooling Time-Dependent Coefficients
(ZR-Clad Fuel)

Cooling Time (years)	Array/Class 15x15A/B/C						
	A	B	C	D	E	F	G
≥ 3	15037.3	108.689	-18.8378	-127.422	2050.02	-242.828	-580.66
≥ 4	25506.6	-2994.03	356.834	-116.45	2430.25	-350.901	-356.378
≥ 5	34788.8	-7173.07	1065.9	-124.785	2712.23	-424.681	267.705
≥ 6	41948.6	-11225.3	1912.12	-145.727	3003.29	-489.538	852.112
≥ 7	47524.9	-14770.9	2755.16	-165.889	3253.9	-542.7	1146.96
≥ 8	52596.9	-18348.8	3699.72	-177.17	3415.69	-567.012	1021.41
≥ 9	56055.4	-20837.1	4430.93	-192.168	3625.93	-623.325	1058.61
≥ 10	59611.3	-23402.1	5179.52	-195.105	3699.18	-626.448	868.517
≥ 11	62765.3	-25766.5	5924.71	-195.57	3749.91	-627.139	667.124
≥ 12	65664.4	-28004.8	6670.75	-195.08	3788.33	-628.904	410.783
≥ 13	67281.7	-29116.7	7120.59	-202.817	3929.38	-688.738	492.309
≥ 14	69961.4	-31158.6	7834.02	-197.988	3917.29	-677.565	266.561
≥ 15	72146	-32795.7	8453.67	-195.083	3931.47	-681.037	99.0606
≥ 16	74142.6	-34244.8	9023.57	-190.645	3905.54	-663.682	10.8885
≥ 17	76411.4	-36026.3	9729.98	-188.874	3911.21	-663.449	-151.805
≥ 18	77091	-36088	9884.09	-188.554	3965.08	-708.55	59.3839
≥ 19	79194.5	-37566.4	10477.5	-181.656	3906.93	-682.4	-117.952
≥ 20	81600.4	-39464.5	11281.9	-175.182	3869.49	-677.179	-367.705

Table 2.4-3 (Page 5 of 8)

PWR Fuel Assembly Cooling Time-Dependent Coefficients
(ZR-Clad Fuel)

Cooling Time (years)	Array/Class 15x15D/E/F/H						
	A	B	C	D	E	F	G
≥ 3	14376.7	102.205	-20.6279	-126.017	1903.36	-210.883	-493.065
≥ 4	24351.4	-2686.57	297.975	-110.819	2233.78	-301.615	-152.713
≥ 5	33518.4	-6711.35	958.544	-122.85	2522.7	-371.286	392.608
≥ 6	40377	-10472.4	1718.53	-144.535	2793.29	-426.436	951.528
≥ 7	46105.8	-13996.2	2515.32	-157.827	2962.46	-445.314	1100.56
≥ 8	50219.7	-16677.7	3198.3	-175.057	3176.74	-492.727	1223.62
≥ 9	54281.2	-19555.6	3983.47	-181.703	3279.03	-499.997	1034.55
≥ 10	56761.6	-21287.3	4525.98	-195.045	3470.41	-559.074	1103.3
≥ 11	59820	-23445.2	5165.43	-194.997	3518.23	-561.422	862.68
≥ 12	62287.2	-25164.6	5709.9	-194.771	3552.69	-561.466	680.488
≥ 13	64799	-27023.7	6335.16	-192.121	3570.41	-561.326	469.583
≥ 14	66938.7	-28593.1	6892.63	-194.226	3632.92	-583.997	319.867
≥ 15	68116.5	-29148.6	7140.09	-192.545	3670.39	-607.278	395.344
≥ 16	70154.9	-30570.1	7662.91	-187.366	3649.14	-597.205	232.318
≥ 17	72042.5	-31867.6	8169.01	-183.453	3646.92	-603.907	96.0388
≥ 18	73719.8	-32926.1	8596.12	-177.896	3614.57	-592.868	46.6774
≥ 19	75183.1	-33727.4	8949.64	-172.386	3581.13	-586.347	3.57256
≥ 20	77306.1	-35449	9690.02	-173.784	3636.87	-626.321	-205.513

Table 2.4-3 (Page 6 of 8)

PWR Fuel Assembly Cooling Time-Dependent Coefficients
(ZR-Clad Fuel)

Cooling Time (years)	Array/Class 16X16A						
	A	B	C	D	E	F	G
≥ 3	16226.8	143.714	-32.4809	-136.707	2255.33	-291.683	-699.947
≥ 4	27844.2	-3590.69	444.838	-124.301	2644.09	-411.598	-381.106
≥ 5	38191.5	-8678.48	1361.58	-132.855	2910.45	-473.183	224.473
≥ 6	46382.2	-13819.6	2511.32	-158.262	3216.92	-532.337	706.656
≥ 7	52692.3	-18289	3657.18	-179.765	3488.3	-583.133	908.839
≥ 8	57758.7	-22133.7	4736.88	-199.014	3717.42	-618.83	944.903
≥ 9	62363.3	-25798.7	5841.18	-207.025	3844.38	-625.741	734.928
≥ 10	66659.1	-29416.3	6993.31	-216.458	3981.97	-642.641	389.366
≥ 11	69262.7	-31452.7	7724.66	-220.836	4107.55	-681.043	407.121
≥ 12	72631.5	-34291.9	8704.8	-219.929	4131.5	-662.513	100.093
≥ 13	75375.3	-36589.3	9555.88	-217.994	4143.15	-644.014	-62.3294
≥ 14	78178.7	-39097.1	10532	-221.923	4226.28	-667.012	-317.743
≥ 15	79706.3	-40104	10993.3	-218.751	4242.12	-670.665	-205.579
≥ 16	82392.6	-42418.9	11940.7	-216.278	4274.09	-689.236	-479.752
≥ 17	84521.8	-44150.5	12683.3	-212.056	4245.99	-665.418	-558.901
≥ 18	86777.1	-45984.8	13479	-204.867	4180.8	-621.805	-716.366
≥ 19	89179.7	-48109.8	14434.5	-206.484	4230.03	-648.557	-902.1
≥ 20	90141.7	-48401.4	14702.6	-203.284	4245.54	-670.655	-734.604

Table 2.4-3 (Page 7 of 8)

PWR Fuel Assembly Cooling Time-Dependent Coefficients
(ZR-Clad Fuel)

Cooling Time (years)	Array/Class 17x17A/16x16B/C						
	A	B	C	D	E	F	G
≥ 3	15985.1	3.53963	-9.04955	-128.835	2149.5	-260.415	-262.997
≥ 4	27532.9	-3494.41	428.199	-119.504	2603.01	-390.91	-140.319
≥ 5	38481.2	-8870.98	1411.03	-139.279	3008.46	-492.881	388.377
≥ 6	47410.9	-14479.6	2679.08	-162.13	3335.48	-557.777	702.164
≥ 7	54596.8	-19703.2	4043.46	-181.339	3586.06	-587.634	804.05
≥ 8	60146.1	-24003.4	5271.54	-201.262	3830.32	-621.706	848.454
≥ 9	65006.3	-27951	6479.04	-210.753	3977.69	-627.805	615.84
≥ 10	69216	-31614.7	7712.58	-222.423	4173.4	-672.33	387.879
≥ 11	73001.3	-34871.1	8824.44	-225.128	4238.28	-657.259	101.654
≥ 12	76326.1	-37795.9	9887.35	-226.731	4298.11	-647.55	-122.236
≥ 13	78859.9	-40058.9	10797.1	-231.798	4402.14	-669.982	-203.383
≥ 14	82201.3	-43032.5	11934.1	-228.162	4417.99	-661.61	-561.969
≥ 15	84950	-45544.6	12972.4	-225.369	4417.84	-637.422	-771.254
≥ 16	87511.8	-47720	13857.7	-219.255	4365.24	-585.655	-907.775
≥ 17	90496.4	-50728.9	15186	-223.019	4446.51	-613.378	-1200.94
≥ 18	91392.5	-51002.4	15461.4	-220.272	4475.28	-636.398	-1003.81
≥ 19	94343.9	-53670.8	16631.6	-214.045	4441.31	-616.201	-1310.01
≥ 20	96562.9	-55591.2	17553.4	-209.917	4397.67	-573.199	-1380.64

Table 2.4-3 (Page 8 of 8)

PWR Fuel Assembly Cooling Time-Dependent Coefficients
(ZR-Clad Fuel)

Cooling Time (years)	Array/Class 17x17B/C						
	A	B	C	D	E	F	G
≥ 3	14738	47.5402	-13.8187	-127.895	1946.58	-219.289	-389.029
≥ 4	25285.2	-3011.92	350.116	-115.75	2316.89	-319.23	-220.413
≥ 5	34589.6	-7130.34	1037.26	-128.673	2627.27	-394.58	459.642
≥ 6	42056.2	-11353.7	1908.68	-150.234	2897.38	-444.316	923.971
≥ 7	47977.6	-15204.8	2827.4	-173.349	3178.25	-504.16	1138.82
≥ 8	52924	-18547.6	3671.08	-183.025	3298.64	-501.278	1064.68
≥ 9	56465.5	-21139.4	4435.67	-200.386	3538	-569.712	1078.78
≥ 10	60190.9	-23872.7	5224.31	-203.233	3602.88	-562.312	805.336
≥ 11	63482.1	-26431.1	6035.79	-205.096	3668.84	-566.889	536.011
≥ 12	66095	-28311.8	6637.72	-204.367	3692.68	-555.305	372.223
≥ 13	67757.4	-29474.4	7094.08	-211.649	3826.42	-606.886	437.412
≥ 14	70403.7	-31517.4	7807.15	-207.668	3828.69	-601.081	183.09
≥ 15	72506.5	-33036.1	8372.59	-203.428	3823.38	-594.995	47.5175
≥ 16	74625.2	-34620.5	8974.32	-199.003	3798.57	-573.098	-95.0221
≥ 17	76549	-35952.6	9498.14	-193.459	3766.52	-556.928	-190.662
≥ 18	77871.9	-36785.5	9916.91	-195.592	3837.65	-599.45	-152.261
≥ 19	79834.8	-38191.6	10501.9	-190.83	3812.46	-589.635	-286.847
≥ 20	81975.5	-39777.2	11174.5	-185.767	3795.78	-595.664	-475.978

Table 2.4-4 (Page 1 of 10)

BWR Fuel Assembly Cooling Time-Dependent Coefficients
(ZR-Clad Fuel)

Cooling Time (years)	Array/Class 7x7B						
	A	B	C	D	E	F	G
≥ 3	26409.1	28347.5	-16858	-147.076	5636.32	-1606.75	1177.88
≥ 4	61967.8	-6618.31	-4131.96	-113.949	6122.77	-2042.85	-96.7439
≥ 5	91601.1	-49298.3	17826.5	-132.045	6823.14	-2418.49	-185.189
≥ 6	111369	-80890.1	35713.8	-150.262	7288.51	-2471.1	86.6363
≥ 7	126904	-108669	53338.1	-167.764	7650.57	-2340.78	150.403
≥ 8	139181	-132294	69852.5	-187.317	8098.66	-2336.13	97.5285
≥ 9	150334	-154490	86148.1	-193.899	8232.84	-2040.37	-123.029
≥ 10	159897	-173614	100819	-194.156	8254.99	-1708.32	-373.605
≥ 11	166931	-186860	111502	-193.776	8251.55	-1393.91	-543.677
≥ 12	173691	-201687	125166	-202.578	8626.84	-1642.3	-650.814
≥ 13	180312	-215406	137518	-201.041	8642.19	-1469.45	-810.024
≥ 14	185927	-227005	148721	-197.938	8607.6	-1225.95	-892.876
≥ 15	191151	-236120	156781	-191.625	8451.86	-846.27	-1019.4
≥ 16	195761	-244598	165372	-187.043	8359.19	-572.561	-1068.19
≥ 17	200791	-256573	179816	-197.26	8914.28	-1393.37	-1218.63
≥ 18	206068	-266136	188841	-187.191	8569.56	-730.898	-1363.79
≥ 19	210187	-273609	197794	-182.151	8488.23	-584.727	-1335.59
≥ 20	213731	-278120	203074	-175.864	8395.63	-457.304	-1364.38

Table 2.4-4 (Page 2 of 10)

BWR Fuel Assembly Cooling Time-Dependent Coefficients
(ZR-Clad Fuel)

Cooling Time (years)	Array/Class 8x8B						
	A	B	C	D	E	F	G
≥ 3	28219.6	28963.7	-17616.2	-147.68	5887.41	-1730.96	1048.21
≥ 4	66061.8	-10742.4	-1961.82	-123.066	6565.54	-2356.05	-298.005
≥ 5	95790.7	-53401.7	19836.7	-134.584	7145.41	-2637.09	-298.858
≥ 6	117477	-90055.9	41383.9	-154.758	7613.43	-2612.69	-64.9921
≥ 7	134090	-120643	60983	-168.675	7809	-2183.3	-40.8885
≥ 8	148186	-149181	81418.7	-185.726	8190.07	-2040.31	-260.773
≥ 9	159082	-172081	99175.2	-197.185	8450.86	-1792.04	-381.705
≥ 10	168816	-191389	113810	-195.613	8359.87	-1244.22	-613.594
≥ 11	177221	-210599	131099	-208.3	8810	-1466.49	-819.773
≥ 12	183929	-224384	143405	-207.497	8841.33	-1227.71	-929.708
≥ 13	191093	-240384	158327	-204.95	8760.17	-811.708	-1154.76
≥ 14	196787	-252211	169664	-204.574	8810.95	-610.928	-1208.97
≥ 15	203345	-267656	186057	-208.962	9078.41	-828.954	-1383.76
≥ 16	207973	-276838	196071	-204.592	9024.17	-640.808	-1436.43
≥ 17	213891	-290411	211145	-202.169	9024.19	-482.1	-1595.28
≥ 18	217483	-294066	214600	-194.243	8859.35	-244.684	-1529.61
≥ 19	220504	-297897	219704	-190.161	8794.97	-10.9863	-1433.86
≥ 20	227821	-318395	245322	-194.682	9060.96	-350.308	-1741.16

Table 2.4-4 (Page 3 of 10)

BWR Fuel Assembly Cooling Time-Dependent Coefficients
(ZR-Clad Fuel)

Cooling Time (years)	Array/Class 8x8C/D/E						
	A	B	C	D	E	F	G
≥ 3	28592.7	28691.5	-17773.6	-149.418	5969.45	-1746.07	1063.62
≥ 4	66720.8	-12115.7	-1154	-128.444	6787.16	-2529.99	-302.155
≥ 5	96929.1	-55827.5	21140.3	-136.228	7259.19	-2685.06	-334.328
≥ 6	118190	-92000.2	42602.5	-162.204	7907.46	-2853.42	-47.5465
≥ 7	135120	-123437	62827.1	-172.397	8059.72	-2385.81	-75.0053
≥ 8	149162	-152986	84543.1	-195.458	8559.11	-2306.54	-183.595
≥ 9	161041	-177511	103020	-200.087	8632.84	-1864.4	-433.081
≥ 10	171754	-201468	122929	-209.799	8952.06	-1802.86	-755.742
≥ 11	179364	-217723	137000	-215.803	9142.37	-1664.82	-847.268
≥ 12	186090	-232150	150255	-216.033	9218.36	-1441.92	-975.817
≥ 13	193571	-249160	165997	-213.204	9146.99	-1011.13	-1119.47
≥ 14	200034	-263671	180359	-210.559	9107.54	-694.626	-1312.55
≥ 15	205581	-275904	193585	-216.242	9446.57	-1040.65	-1428.13
≥ 16	212015	-290101	207594	-210.036	9212.93	-428.321	-1590.7
≥ 17	216775	-299399	218278	-204.611	9187.86	-398.353	-1657.6
≥ 18	220653	-306719	227133	-202.498	9186.34	-181.672	-1611.86
≥ 19	224859	-314004	235956	-193.902	8990.14	145.151	-1604.71
≥ 20	228541	-320787	245449	-200.727	9310.87	-230.252	-1570.18

Table 2.4-4 (Page 4 of 10)

BWR Fuel Assembly Cooling Time-Dependent Coefficients
(ZR-Clad Fuel)

Cooling Time (years)	Array/Class 9x9A						
	A	B	C	D	E	F	G
≥ 3	30538.7	28463.2	-18105.5	-150.039	6226.92	-1876.69	1034.06
≥ 4	71040.1	-16692.2	1164.15	-128.241	7105.27	-2728.58	-414.09
≥ 5	100888	-60277.7	24150.1	-142.541	7896.11	-3272.86	-232.197
≥ 6	124846	-102954	50350.8	-161.849	8350.16	-3163.44	-91.1396
≥ 7	143516	-140615	76456.5	-185.538	8833.04	-2949.38	-104.802
≥ 8	158218	-171718	99788.2	-196.315	9048.88	-2529.26	-259.929
≥ 9	172226	-204312	126620	-214.214	9511.56	-2459.19	-624.954
≥ 10	182700	-227938	146736	-215.793	9555.41	-1959.92	-830.943
≥ 11	190734	-246174	163557	-218.071	9649.43	-1647.5	-935.021
≥ 12	199997	-269577	186406	-223.975	9884.92	-1534.34	-1235.27
≥ 13	207414	-287446	204723	-228.808	10131.7	-1614.49	-1358.61
≥ 14	215263	-306131	223440	-220.919	9928.27	-988.276	-1638.05
≥ 15	221920	-321612	239503	-217.949	9839.02	-554.709	-1784.04
≥ 16	226532	-331778	252234	-216.189	9893.43	-442.149	-1754.72
≥ 17	232959	-348593	272609	-219.907	10126.3	-663.84	-1915.3
≥ 18	240810	-369085	296809	-219.729	10294.6	-859.302	-2218.87
≥ 19	244637	-375057	304456	-210.997	10077.8	-425.446	-2127.83
≥ 20	248112	-379262	309391	-204.191	9863.67	100.27	-2059.39

Table 2.4-4 (Page 5 of 10)

BWR Fuel Assembly Cooling Time-Dependent Coefficients
(ZR-Clad Fuel)

Cooling Time (years)	Array/Class 9x9B						
	A	B	C	D	E	F	G
≥ 3	30613.2	28985.3	-18371	-151.117	6321.55	-1881.28	988.92
≥ 4	71346.6	-15922.9	631.132	-128.876	7232.47	-2810.64	-471.737
≥ 5	102131	-60654.1	23762.7	-140.748	7881.6	-3156.38	-417.979
≥ 6	127187	-105842	51525.2	-162.228	8307.4	-2913.08	-342.13
≥ 7	146853	-145834	79146.5	-185.192	8718.74	-2529.57	-484.885
≥ 8	162013	-178244	103205	-197.825	8896.39	-1921.58	-584.013
≥ 9	176764	-212856	131577	-215.41	9328.18	-1737.12	-1041.11
≥ 10	186900	-235819	151238	-218.98	9388.08	-1179.87	-1202.83
≥ 11	196178	-257688	171031	-220.323	9408.47	-638.53	-1385.16
≥ 12	205366	-280266	192775	-223.715	9592.12	-472.261	-1661.6
≥ 13	215012	-306103	218866	-231.821	9853.37	-361.449	-1985.56
≥ 14	222368	-324558	238655	-228.062	9834.57	3.47358	-2178.84
≥ 15	226705	-332738	247316	-224.659	9696.59	632.172	-2090.75
≥ 16	233846	-349835	265676	-221.533	9649.93	913.747	-2243.34
≥ 17	243979	-379622	300077	-222.351	9792.17	1011.04	-2753.36
≥ 18	247774	-386203	308873	-220.306	9791.37	1164.58	-2612.25
≥ 19	254041	-401906	327901	-213.96	9645.47	1664.94	-2786.2
≥ 20	256003	-402034	330566	-215.242	9850.42	1359.46	-2550.06

Table 2.4-4 (Page 6 of 10)

BWR Fuel Assembly Cooling Time-Dependent Coefficients
(ZR-Clad Fuel)

Cooling Time (years)	Array/Class 9x9C/D						
	A	B	C	D	E	F	G
≥ 3	30051.6	29548.7	-18614.2	-148.276	6148.44	-1810.34	1006
≥ 4	70472.7	-14696.6	-233.567	-127.728	7008.69	-2634.22	-444.373
≥ 5	101298	-59638.9	23065.2	-138.523	7627.57	-2958.03	-377.965
≥ 6	125546	-102740	49217.4	-160.811	8096.34	-2798.88	-259.767
≥ 7	143887	-139261	74100.4	-184.302	8550.86	-2517.19	-275.151
≥ 8	159633	-172741	98641.4	-194.351	8636.89	-1838.81	-486.731
≥ 9	173517	-204709	124803	-212.604	9151.98	-1853.27	-887.137
≥ 10	182895	-225481	142362	-218.251	9262.59	-1408.25	-978.356
≥ 11	192530	-247839	162173	-217.381	9213.58	-818.676	-1222.12
≥ 12	201127	-268201	181030	-215.552	9147.44	-232.221	-1481.55
≥ 13	209538	-289761	203291	-225.092	9588.12	-574.227	-1749.35
≥ 14	216798	-306958	220468	-222.578	9518.22	-69.9307	-1919.71
≥ 15	223515	-323254	237933	-217.398	9366.52	475.506	-2012.93
≥ 16	228796	-334529	250541	-215.004	9369.33	662.325	-2122.75
≥ 17	237256	-356311	273419	-206.483	9029.55	1551.3	-2367.96
≥ 18	242778	-369493	290354	-215.557	9600.71	659.297	-2589.32
≥ 19	246704	-377971	302630	-210.768	9509.41	1025.34	-2476.06
≥ 20	249944	-382059	308281	-205.495	9362.63	1389.71	-2350.49

Table 2.4-4 (Page 7 of 10)

BWR Fuel Assembly Cooling Time-Dependent Coefficients
(ZR-Clad Fuel)

Cooling Time (years)	Array/Class 9x9E/F						
	A	B	C	D	E	F	G
≥ 3	30284.3	26949.5	-16926.4	-147.914	6017.02	-1854.81	1026.15
≥ 4	69727.4	-17117.2	1982.33	-127.983	6874.68	-2673.01	-359.962
≥ 5	98438.9	-58492	23382.2	-138.712	7513.55	-3038.23	-112.641
≥ 6	119765	-95024.1	45261	-159.669	8074.25	-3129.49	221.182
≥ 7	136740	-128219	67940.1	-182.439	8595.68	-3098.17	315.544
≥ 8	150745	-156607	88691.5	-193.941	8908.73	-2947.64	142.072
≥ 9	162915	-182667	109134	-198.37	8999.11	-2531	-93.4908
≥ 10	174000	-208668	131543	-210.777	9365.52	-2511.74	-445.876
≥ 11	181524	-224252	145280	-212.407	9489.67	-2387.49	-544.123
≥ 12	188946	-240952	160787	-210.65	9478.1	-2029.94	-652.339
≥ 13	193762	-250900	171363	-215.798	9742.31	-2179.24	-608.636
≥ 14	203288	-275191	196115	-218.113	9992.5	-2437.71	-1065.92
≥ 15	208108	-284395	205221	-213.956	9857.25	-1970.65	-1082.94
≥ 16	215093	-301828	224757	-209.736	9789.58	-1718.37	-1303.35
≥ 17	220056	-310906	234180	-201.494	9541.73	-1230.42	-1284.15
≥ 18	224545	-320969	247724	-206.807	9892.97	-1790.61	-1381.9
≥ 19	226901	-322168	250395	-204.073	9902.14	-1748.78	-1253.22
≥ 20	235561	-345414	276856	-198.306	9720.78	-1284.14	-1569.18

Table 2.4-4 (Page 8 of 10)

BWR Fuel Assembly Cooling Time-Dependent Coefficients
(ZR-Clad Fuel)

Cooling Time (years)	Array/Class 9x9G						
	A	B	C	D	E	F	G
≥ 3	35158.5	26918.5	-17976.7	-149.915	6787.19	-2154.29	836.894
≥ 4	77137.2	-19760.1	2371.28	-130.934	8015.43	-3512.38	-455.424
≥ 5	113405	-77931.2	35511.2	-150.637	8932.55	-4099.48	-629.806
≥ 6	139938	-128700	68698.3	-173.799	9451.22	-3847.83	-455.905
≥ 7	164267	-183309	109526	-193.952	9737.91	-3046.84	-737.992
≥ 8	182646	-227630	146275	-210.936	10092.3	-2489.3	-1066.96
≥ 9	199309	-270496	184230	-218.617	10124.3	-1453.81	-1381.41
≥ 10	213186	-308612	221699	-235.828	10703.2	-1483.31	-1821.73
≥ 11	225587	-342892	256242	-236.112	10658.5	-612.076	-2134.65
≥ 12	235725	-370471	285195	-234.378	10604.9	118.591	-2417.89
≥ 13	247043	-404028	323049	-245.79	11158.2	-281.813	-2869.82
≥ 14	253649	-421134	342682	-243.142	11082.3	400.019	-2903.88
≥ 15	262750	-448593	376340	-245.435	11241.2	581.355	-3125.07
≥ 16	270816	-470846	402249	-236.294	10845.4	1791.46	-3293.07
≥ 17	279840	-500272	441964	-241.324	11222.6	1455.84	-3528.25
≥ 18	284533	-511287	458538	-240.905	11367.2	1459.68	-3520.94
≥ 19	295787	-545885	501824	-235.685	11188.2	2082.21	-3954.2
≥ 20	300209	-556936	519174	-229.539	10956	2942.09	-3872.87

Table 2.4-4 (Page 9 of 10)

BWR Fuel Assembly Cooling Time-Dependent Coefficients
(ZR-Clad Fuel)

Cooling Time (years)	Array/Class 10x10A/B						
	A	B	C	D	E	F	G
≥ 3	29285.4	27562.2	-16985	-148.415	5960.56	-1810.79	1001.45
≥ 4	67844.9	-14383	395.619	-127.723	6754.56	-2547.96	-369.267
≥ 5	96660.5	-55383.8	21180.4	-137.17	7296.6	-2793.58	-192.85
≥ 6	118098	-91995	42958	-162.985	7931.44	-2940.84	60.9197
≥ 7	135115	-123721	63588.9	-171.747	8060.23	-2485.59	73.6219
≥ 8	148721	-151690	84143.9	-190.26	8515.81	-2444.25	-63.4649
≥ 9	160770	-177397	104069	-197.534	8673.6	-2101.25	-331.046
≥ 10	170331	-198419	121817	-213.692	9178.33	-2351.54	-472.844
≥ 11	179130	-217799	138652	-209.75	9095.43	-1842.88	-705.254
≥ 12	186070	-232389	151792	-208.946	9104.52	-1565.11	-822.73
≥ 13	192407	-246005	164928	-209.696	9234.7	-1541.54	-979.245
≥ 14	200493	-265596	183851	-207.639	9159.83	-1095.72	-1240.61
≥ 15	205594	-276161	195760	-213.491	9564.23	-1672.22	-1333.64
≥ 16	209386	-282942	204110	-209.322	9515.83	-1506.86	-1286.82
≥ 17	214972	-295149	217095	-202.445	9292.34	-893.6	-1364.97
≥ 18	219312	-302748	225826	-198.667	9272.27	-878.536	-1379.58
≥ 19	223481	-310663	235908	-194.825	9252.9	-785.066	-1379.62
≥ 20	227628	-319115	247597	-199.194	9509.02	-1135.23	-1386.19

Table 2.4-4 (Page 10 of 10)

BWR Fuel Assembly Cooling Time-Dependent Coefficients
(ZR-Clad Fuel)

Cooling Time (years)	Array/Class 10x10C						
	A	B	C	D	E	F	G
≥ 3	31425.3	27358.9	-17413.3	-152.096	6367.53	-1967.91	925.763
≥ 4	71804	-16964.1	1000.4	-129.299	7227.18	-2806.44	-416.92
≥ 5	102685	-62383.3	24971.2	-142.316	7961	-3290.98	-354.784
≥ 6	126962	-105802	51444.6	-164.283	8421.44	-3104.21	-186.615
≥ 7	146284	-145608	79275.5	-188.967	8927.23	-2859.08	-251.163
≥ 8	162748	-181259	105859	-199.122	9052.91	-2206.31	-554.124
≥ 9	176612	-214183	133261	-217.56	9492.17	-1999.28	-860.669
≥ 10	187756	-239944	155315	-219.56	9532.45	-1470.9	-1113.42
≥ 11	196580	-260941	174536	-222.457	9591.64	-944.473	-1225.79
≥ 12	208017	-291492	204805	-233.488	10058.3	-1217.01	-1749.84
≥ 13	214920	-307772	221158	-234.747	10137.1	-897.23	-1868.04
≥ 14	222562	-326471	240234	-228.569	9929.34	-183.47	-2016.12
≥ 15	228844	-342382	258347	-226.944	9936.76	117.061	-2106.05
≥ 16	233907	-353008	270390	-223.179	9910.72	360.39	-2105.23
≥ 17	244153	-383017	304819	-227.266	10103.2	380.393	-2633.23
≥ 18	249240	-395456	321452	-226.989	10284.1	169.947	-2623.67
≥ 19	254343	-406555	335240	-220.569	10070.5	764.689	-2640.2
≥ 20	260202	-421069	354249	-216.255	10069.9	854.497	-2732.77

3.0 DESIGN FEATURES

3.1 Site

3.1.1 Site Location

The HI-STORM 100 Cask System is authorized for use at various site locations under the general license provisions of 10 CFR 72, Subpart K.

3.2 Design Features Important for Criticality Control

3.2.1 MPC-24

1. Flux trap size: ≥ 1.09 in.
2. ^{10}B loading in the neutron absorbers: ≥ 0.0267 g/cm² (Boral) and ≥ 0.0223 g/cm² (METAMIC)

3.2.2 MPC-68

1. Fuel cell pitch: ≥ 6.43 in.
2. ^{10}B loading in the neutron absorbers: ≥ 0.0372 g/cm² (Boral) and ≥ 0.0310 g/cm² (METAMIC)

3.2.3 MPC-24E

1. Flux trap size:
 - i. Cells 3, 6, 19, and 22: ≥ 0.776 inch
 - ii. All Other Cells: ≥ 1.076 inches
2. ^{10}B loading in the neutron absorbers: ≥ 0.0372 g/cm² (Boral) and ≥ 0.0310 g/cm² (METAMIC)

3.2.4 MPC-32

1. Fuel cell pitch: ≥ 9.158 inches
2. ^{10}B loading in the neutron absorbers: ≥ 0.0372 g/cm² (Boral) and ≥ 0.0310 g/cm² (METAMIC)

3.2.5 Not Used

DESIGN FEATURES

3.2 Design features Important for Criticality Control (cont'd)

3.2.6 Fuel spacers shall be sized to ensure that the active fuel region of intact fuel assemblies remains within the neutron poison region of the MPC basket with water in the MPC.

3.2.7 The B₄C content in METAMIC shall be ≤ 33.0 wt.%.

3.2.8 Neutron Absorber Tests

Section 9.1.5.3 of the HI-STORM 100 FSAR is hereby incorporated by reference into the HI-STORM 100 CoC. The minimum ¹⁰B for the neutron absorber shall meet the minimum requirements for each MPC model specified in Sections 3.2.1 through 3.2.4 above.

3.3 Codes and Standards

The American Society of Mechanical Engineers Boiler and Pressure Vessel Code (ASME Code), 1995 Edition with Addenda through 1997, is the governing Code for the HI-STORM 100 System MPCs, OVERPACKs, and TRANSFER CASKs, as clarified in Specification 3.3.1 below, except for Code Sections V and IX. The ASME Code paragraphs applicable to the 100U VVM are listed in Table 3-2. The latest effective editions of ASME Code Sections V and IX, including addenda, may be used for activities governed by those sections, provided a written reconciliation of the later edition against the 1995 Edition, including addenda, is performed by the certificate holder. American Concrete Institute (ACI) 349-85 is the governing Code for plain concrete as clarified in Appendix 1.D of the Final Safety Analysis Report for the HI-STORM 100 Cask System.

3.3.1 Alternatives to Codes, Standards, and Criteria

Table 3-1 of Appendix B to CoC-1014 lists approved alternatives to the ASME Code for the design of the MPCs and TRANSFER CASKs of the HI-STORM 100U System.

3.3.2 Construction/Fabrication Alternatives to Codes, Standards, and Criteria

Proposed alternatives to the ASME Code, Section III, 1995 Edition with Addenda through 1997 including modifications to the alternatives allowed by Specification 3.3.1 may be used on a case-specific basis when authorized by the Director of the Office of Nuclear Material Safety and Safeguards or designee. The request for such alternative should demonstrate that:

1. The proposed alternatives would provide an acceptable level of quality and safety, or

(continued)

DESIGN FEATURES

3.3.2 Construction/Fabrication Alternatives to Codes, Standards, and Criteria
(cont'd)

2. Compliance with the specified requirements of the ASME Code, Section III, 1995 Edition with Addenda through 1997, would result in hardship or unusual difficulty without a compensating increase in the level of quality and safety.

Requests for alternatives shall be submitted in accordance with 10 CFR 72.4.

(continued)

DESIGN FEATURES

Table 3-1: Not Used

**Table 3-2
Applicable Code Paragraphs for Underground VVMs**

	Item	Code Paragraph[†]	Explanation and Applicability
1.	Definition of primary and secondary members	NF-1215	
2.	Jurisdictional boundary	NF-1133	The “intervening elements” are termed interfacing SSCs in this FSAR.
3.	Certification of Material	NF-2130(b) and (c)	Materials shall be certified to the applicable Section II of the ASME Code or equivalent ASTM Specification.
4.	Heat treatment of material	NF-2170 and NF-2180	
5.	Storage of welding material	NF-2400	
6.	Structural Analysis of Interfacing SSCs	ACI 318-05	The VVM Interface Pad and Support Foundation are reinforced concrete structures. Loadings come from the external environment and from the VVM. Sections of the Code that may reasonably be applied to subterranean application are applicable.
7.	Welding procedure	Section IX	
8.	Welding material	Section II	
9.	Loading conditions	NF-3111	
10.	Allowable stress values	NF-3112.3	
11.	Rolling and sliding supports	NF-3424	
12.	Differential thermal expansion	NF-3127	
13.	Stress analysis	NF-3143 NF-3380 NF-3522 NF-3523	Provisions for stress analysis for Class 3 plate and shell supports and for linear supports are applicable for CEC shells and CLOSURE LID.
14.	Cutting of plate stock	NF-4211 NF-4211.1	
15.	Forming	NF-4212	
16.	Forming tolerance	NF-4221	Applies to the CEC Divider Shell and CEC Container Shell
17.	Fitting and Aligning Tack Welds	NF-4231 NF-4231.1	
18.	Alignment	NF-4232	
19.	Storage of Welding Materials	NF-4411	
20.	Cleanliness of Weld Surfaces	NF-4412	Applies to structural and non-structural welds

Table 3-2 (continued)
Applicable Code Paragraphs for Underground VVMs

	Item	Code Paragraph[†]	Explanation and Applicability
21.	Backing Strips, Peening	NF-4421 NF-4422	Applies to structural and non-structural welds
22.	Pre-heating and Interpass Temperature	NF-4611 NF-4612 NF-4613	Applies to structural and non-structural welds
23.	Non-Destructive Examination	NF-5360	Invokes Section V
24.	NDE Personnel Certification	NF-5522 NF-5523 NF-5530	-

† All references to the ASME Code refer to applicable sections of the 1995 edition with addenda through 1997, except for Code Sections V and IX, where the latest effective editions of ASME Code Sections V and IX, including addenda, may be used, provided a written reconciliation of the later edition against the 1995 Edition, including addenda, is performed by the certificate holder.

DESIGN FEATURES (continued)

3.4 Site-Specific Parameters and Analyses

Site-specific parameters and analyses that will require verification by the system user are, as a minimum, as follows:

1. The temperature of 80° F is the maximum average yearly temperature.
2. The allowed temperature extremes, averaged over a 3-day period, shall be greater than -40° F and less than 125° F.
3. The analyzed flood condition of 15 fps water velocity and a height of 125 feet of water (full submergence of the loaded cask) are not exceeded.
4. The potential for fire and explosion shall be addressed, based on site-specific considerations. The user shall demonstrate that the site-specific potential for fire is bounded by the fire conditions analyzed by the Certificate Holder, or an analysis of the site-specific fire considerations shall be performed.
5. The resultant zero period acceleration at the top of the grade and at the elevation of the Support Foundation Pad (SFP) at the host site (computed by the Newmark's rule as the sum of $A+0.4*B+0.4*C$, where A, B, C denote the free field ZPA's in the three orthogonal directions in decreasing magnitude, i.e., $A \geq B \geq C$) shall be less than or equal to 1.3 and 1.228, respectively.
6.
 - a. The criteria used to qualify the protection of the reactor building base mat foundation at the nuclear plant shall also be used to insure that sub-grade supporting the SFP shall not violate the plant's acceptance criteria for the potential of liquefaction.
 - b. The depth averaged densities and strain compatible shear wave velocities in the different regions of the subgrade shall meet the minimum requirements of Table 3-4.
7. The moment and shear capacities of the ISFSI Structures shall meet the structural requirements under the load combinations in Table 3-3.
8. Radiation Protection Space (RPS) as defined in Subsection 5.7.9 of Appendix A-100U, is intended to ensure that the subgrade material in and around the lateral space occupied by the VVMs remains essentially intact under all service conditions including during an excavation activity adjacent to the RPS.
9. The Support Foundation Pad (mat) for a VVM array established in any one construction campaign shall be of monolithic construction, to the extent practicable, to maximize the physical stability of the underground installation.

(continued)

TABLE 3-3 LOAD COMBINATIONS FOR THE TOP SURFACE PAD, VVM INTERFACE PAD, SUPPORT FOUNDATION PAD, AND THE RETAINING WALL PER ACI-318 (2005)	
Load Combination	
LC-1	1.4D
LC-2	1.2D + 1.6L
LC-3	1.2D + E + L
<p>where:</p> <p>D: Dead Load including long-term differential settlement effects.</p> <p>L: Live Load</p> <p>E: DBE for the Site</p>	

Table 3-4 Values of Principal Design Parameters for the Underground ISFSI	
Thickness of the Support Foundation Pad, inch (nominal)	≥33
Thickness of the VVM Interface Pad, inch (nominal)	≥34
Thickness of the Top Surface Pad, inch (nominal)	≥30
Thickness of Retaining Wall, inch (nominal)	≥24
Rebar Size* (min.) and Layout* (max)	#11 @ 9" each face, each direction
Rebar Concrete Cover (top and bottom)*, inch	per 7.7.1 of ACI 318 (2005)
Compressive Strength of Concrete*, psi	≥4500
Shear Wave Velocity in the Subgrade lateral to the VVM, fps (nominal)	≥500
Shear Wave Velocity in the Subgrade Below the Support Foundation Pad, fps (nominal)	≥485
* Applies to Support Foundation Pad, VVM Interface Pad, Top Surface Pad and Retaining Wall	

(continued)

DESIGN FEATURES (continued)

3.4 Site-Specific Parameters and Analyses (continued)

10. Prior to an excavation activity contiguous to an RPS, a seismic qualification of the ISFSI in the structurally most vulnerable configuration (i.e., maximum amount of earth removed) shall be performed to verify that the stability of the SFP, the TSP and the shielding material within the RPS, with or without the Retaining Wall, is maintained. If a Retaining Wall is not installed in any side of the ISFSI then an Excavation Exclusion Zone shall be established inside which excavation is prohibited by performing an appropriate SSI analysis.
11. In cases where engineered features (i.e., berms and shield walls) are used to ensure that the requirements of 10 CFR 72.104(a) are met, such features are to be considered important to safety and must be evaluated to determine the applicable quality assurance category.
12. LOADING OPERATIONS, TRANSPORT OPERATIONS, and UNLOADING OPERATIONS shall only be conducted with working area ambient temperatures $\geq 0^{\circ}$ F.
13. For those users whose site-specific design basis includes an event or events (e.g., flood) that result in the blockage of any VVM inlet or outlet air ducts for an extended period of time (i.e, longer than the total Completion Time of LCO 3.1.2), an analysis or evaluation may be performed to demonstrate adequate heat removal is available for the duration of the event. Adequate heat removal is defined as fuel cladding temperatures remaining below the short term temperature limit. If the analysis or evaluation is not performed, or if fuel cladding temperature limits are unable to be demonstrated by analysis or evaluation to remain below the short term temperature limit for the duration of the event, provisions shall be established to provide alternate means of cooling to accomplish this objective.
14. Users shall establish procedural and/or mechanical barriers to ensure that during LOADING OPERATIONS and UNLOADING OPERATIONS, either the fuel cladding is covered by water, or the MPC is filled with an inert gas.

DESIGN FEATURES (continued)

3.5 Not Used

(continued)

DESIGN FEATURES (continued)

3.6 Forced Helium Dehydration System

3.6.1 System Description

Use of a forced helium dehydration (FHD) system, (a closed-loop system) is an alternative to vacuum drying the MPC for moderate burnup fuel ($\leq 45,000$ MWD/MTU) with lower MPC heat load and mandatory for drying MPCs containing one or more high burnup fuel assemblies or higher MPC heat load as indicated in Appendix A-100U Table 3-1. The FHD system shall be designed for normal operation (i.e., excluding startup and shutdown ramps) in accordance with the criteria in Section 3.6.2.

3.6.2 Design Criteria

- 3.6.2.1 The temperature of the helium gas in the MPC shall be at least 15°F higher than the saturation temperature at coincident pressure.
- 3.6.2.2 The pressure in the MPC cavity space shall be ≤ 60.3 psig (75 psia) during drying. Backfill pressures shall be as described in Appendix A.
- 3.6.2.3 The hourly recirculation rate of helium shall be ≥ 10 times the nominal helium mass backfilled into the MPC for fuel storage operations.
- 3.6.2.4 The partial pressure of the water vapor in the MPC cavity will not exceed 3 torr. The limit is met if the gas temperature at the demohstrizer outlet is verified by measurement to remain $\leq 21^{\circ}\text{F}$ for a period of 30 minutes or if the dew point of the gas exiting the MPC is verified by measurement to remain $\leq 22.9^{\circ}\text{F}$ for ≥ 30 minutes.
- 3.6.2.5 The condensing module shall be designed to de-vaporize the recirculating helium gas to a dew point $\leq 120^{\circ}\text{F}$.
- 3.6.2.6 The demohstrizing module shall be configured to be introduced into its helium conditioning function after the condensing module has been operated for the required length of time to assure that the bulk moisture vaporization in the MPC (defined as Phase 1 in FSAR Appendix 2.B) has been completed.
- 3.6.2.7 The helium circulator shall be sized to effect the minimum flow rate of circulation required by these design criteria.
- 3.6.2.8 The pre-heater module shall be engineered to ensure that the temperature of the helium gas in the MPC meets these design criteria.

(continued)

DESIGN FEATURES (continued)

3.6 Forced Helium Dehydration System (continued)

3.6.3 Fuel Cladding Temperature

A steady-state thermal analysis of the MPC under the forced helium flow scenario shall be performed using the methodology described in HI-STORM 100 FSAR Section 4.4, with due recognition of the forced convection process during FHD system operation. This analysis shall demonstrate that the peak temperature of the fuel cladding, under the most adverse condition of FHD system operation, is below the peak cladding temperature limit for normal conditions of storage for the applicable fuel type (PWR or BWR) and cooling time at the start of dry storage.

3.6.4 Pressure Monitoring During FHD Malfunction

During an FHD malfunction event, described in HI-STORM 100 FSAR Chapter 11 as a loss of helium circulation, the system pressure must be monitored to ensure that the conditions listed therein are met.

DESIGN FEATURES (continued)

3.7 Deleted

DESIGN FEATURES (continued)

3.8 Combustible Gas Monitoring During MPC Lid Welding and Cutting

During MPC lid-to-shell welding and cutting operations, combustible gas monitoring of the space under the MPC lid is required, to ensure that there is no combustible mixture present.

DESIGN FEATURES (continued)

3.9 Corrosion Mitigation Measures

The HI-STORM 100U VVM CEC Container Shell and Bottom Plate shall be protected from corrosion damage due to the corrosivity of the surrounding environment using the following means:

Implementation and Requirements of Corrosion Mitigation Measures

Surrounding Environment's Corrosivity (see note iv)	Corrosion Mitigation Measures		
	Coating (see note i)	Concrete Encasement (see note ii)	Cathodic Protection (see note iii)
Mild	Required	Choice of either concrete encasement or cathodic protection; or both	
Aggressive	Required	Optional	Required

Notes:

- i. An exterior surface preservative (coating) applied on the CEC in accordance with the acceptance criteria set forth in the FSAR.
- ii. Concrete encasement of the CEC external surfaces to establish a high pH buffer around the CEC metal mass in accordance with the requirements set forth in the FSAR.
- iii. An impressed current cathodic protection system (ICCP) in accordance with the design criteria set forth in the FSAR.
- iv. Surrounding environment corrosivity is categorized as either mild or aggressive in accordance with the requirements set forth in the FSAR.

DESIGN FEATURES (continued)

3.10 Periodic Corrosion Inspections for Underground Systems

HI-STORM 100U VVM ISFSIs not employing an impressed current cathodic protection system shall be subject to visual and UT inspection of at least one representative VVM to check for significant corrosion of the CEC Container Shell and Bottom Plate at an interval not to exceed 20 years. The VVM chosen for inspection is not required to be in use or to have previously contained a loaded MPC. The VVM considered to be most vulnerable to corrosion degradation shall be selected for inspection. If significant corrosion is identified, either an evaluation to demonstrate sufficient continued structural integrity (sufficient for at least the remainder of the licensing period) shall be performed or the affected VVM shall be promptly scheduled for repair or decommissioning. Through wall corrosion shall not be permitted without promptly scheduling for repair or decommissioning. Promptness of repair or decommissioning shall be commensurate with the extent of degradation of the VVM but shall not exceed 3 years from the date of inspection.

If the representative VVM is determined to require repair or decommissioning, the next most vulnerable VVM shall be selected for inspection. This inspection process shall conclude when a VVM is found that does not require repair or decommissioning. Since the last VVM inspected is considered more prone to corrosion than the remaining un-inspected VVMs, the last VVM inspected becomes the representative VVM for the remaining VVMs.

Inspections

Visual Inspection: Visual inspection of the inner surfaces of the CEC Container Shell and Bottom Plate for indications of significant or through wall corrosion (i.e., holes).

UT Inspection: The UT inspection is performed on the inside surfaces of the CEC. A minimum of 16 data points shall be obtained, 4 near the top, 4 near the mid-height and 4 near the bottom of the CEC Container Shell all approximately 0, 90, 180, and 270 degrees apart; and 4 on the CEC Bottom Plate near the CEC Container Shell approximately 0, 90, 180, and 270 degrees apart. Locations where visual inspection has identified potentially significant corrosion shall also receive UT inspection. Locations suspected of significant corrosion may receive further UT inspection to determine the extent of corrosion.

Inspection Criteria

General wall thinning exceeding 1/8" in depth and local pitting exceeding 1/4" in depth are conditions of significant corrosion.