



Revision Log

Revision	Description of Changes
0	Initial Issue.
1	Revision 1 makes minor editorial changes and schedule updates noted through discussion with the NRC staff as well as from the SMR Director.
2	Revision 2 makes minor editorial changes and schedule updates noted through discussion with the NRC staff as well as from the SMR Director.
3	Revision 3 makes changes to Table 3-1 for the Proposed PSAR chapters and schedule updates noted through discussion with the NRC staff as well as from the SMR Director and NRC PMs. Revision 3 will be the schedule update for 1Q23.



Executive Summary

The purpose of this Regulatory Engagement Plan (REP) is to guide interactions and enhance communication between Holtec International (Holtec) and the Nuclear Regulatory Commission (NRC) during the pre-application activities that support the development of a construction permit application (CPA) as part of a two-step license approach under Title 10 of the Code of Federal Regulations (CFR) Part 50, "Domestic licensing of production and utilization facilities". The objective of these pre-application interactions is to ensure a fulsome future application and to address areas of potential licensing risk early in the licensing process.

Section 4.0 articulates the topics where it is envisaged to proceed pre-licensing engagement. This REP is intended as a living document and will be updated as additional topics for engagement are identified.



Table of Contents

1.0 Introduction 4

 1.1 Purpose of Regulatory Engagement Plan 4

 1.2 Contact Information..... 4

 1.3 Company and Project Structure 5

 1.4 Summary of Strategic Approach and Goals 5

2.0 Technology Summary 5

3.0 REP and PSAR Guidance and Content..... 7

 3.1 Selection of Applicable Guidance..... 7

 3.2 Principle Design Criteria..... 10

 3.3 Use of Standards and Industry Guidance..... 11

4.0 Pre-application Engagement..... 11

 4.1 Identification of Topics 11

 4.2 Types and Frequency of Interactions 15

 4.3 Technical Discussions and Written Submittals 16

 4.4 Information Sharing and the Potential Escalation of Issues..... 17

 4.5 Schedule Considerations 17

5.0 Other Topics 18

 5.1 Readiness Assessment Audit and Application Submittal..... 18

 5.2 Budget 18

6.0 References 19

7.0 List of Appendices..... 19

List of Figures

Figure 2-1 Configuration of Combined Vessel..... 7

List of Tables

Table 3-1: Safety Analysis Report Elements per RG 1.206..... 10

Table 3-1: Topics for SMR-160 Pre-Application Engagement..... 13



1.0 INTRODUCTION

1.1 Purpose of Regulatory Engagement Plan

The purpose of this Regulatory Engagement Plan (REP) is to guide interactions and enhance communication between Holtec International (Holtec) and the Nuclear Regulatory Commission (NRC) during the pre-application activities that support the development of a construction permit application (CPA) as part of a two-step license approach under Title 10 of the Code of Federal Regulations (CFR) Part 50, "Domestic licensing of production and utilization facilities". This REP identifies the planned regulatory approach and describes the interactions and roles and responsibilities between Holtec and the NRC staff to establish open communications and minimize regulatory uncertainty with the licensing process.

This REP contains a register of anticipated pre-application engagement topics and approximate schedule for each engagement. This REP is expected to be a living document and will be updated and expanded as plans evolve to support future licensing actions and regulatory decisions. All changes to this REP will be discussed and communicated with the NRC staff. The structure of this plan is based on NEI 18-06, "Guidelines for Development of a Regulatory Engagement Plan" (Reference 1). Holtec will maintain this REP and solicit NRC staff input for consideration and inclusion into the REP.

1.2 Contact Information

The following are points of contact for all correspondence:

Justin Hawkins
Director, SMR Licensing
Holtec International
1 Holtec Boulevard Camden, NJ 08104
Phone: 856-797-0900, ext. 3452
Email: J.Hawkins@holtec.com

Copy to:

Jean Fleming
Vice President, Licensing, Regulatory & PSA
Holtec International
1 Holtec Boulevard Camden, NJ 08104
Phone: 856-797-0900, ext. 3578
Email: J.Fleming@holtec.com

Thomas Marcille
Vice President, SMR Reactor Technologies
SMR, LLC, a wholly owned subsidiary of Holtec International
1 Holtec Boulevard Camden, NJ 08104
Phone: 856-797-0900, ext. 3850
Email: T.Marcille@holtec.com



Rick Trotta
Director, SMR
SMR, LLC, a wholly owned subsidiary of Holtec International
1 Holtec Boulevard Camden, NJ 08104
Phone: 856-797-0900, ext. 3720
Email: R.Trotta@holtec.com

1.3 Company and Project Structure

Holtec International is a diversified energy technology company headquartered in Jupiter, FL. SMR, LLC, based in Camden, NJ, is a wholly owned subsidiary of Holtec International whose designated activities include establishing business alliances with other companies, business and project management of small modular reactor projects, and promoting global acceptance of SMR-160. Licensing interactions for the SMR-160 technology on behalf of SMR, LLC is the responsibility of the Holtec licensing staff. Responsibilities of the Holtec licensing staff will include: (1) develop, maintain and manage the licensing strategy for SMR-160 and (2) to act as the primary point-of-contact (i.e., interface) with the NRC staff.

1.4 Summary of Strategic Approach and Goals

As discussed above, this REP will guide pre-application activities between Holtec and the NRC staff. Holtec plans to use these interactions to inform the future pursuit of a two-step licensing process for the SMR-160 project. Holtec, in collaboration with an owner/operator, intends to submit a power reactor construction permit application (CPA) under 10 CFR Part 50, "Domestic licensing of production and utilization facilities." Per regulation 10 CFR 50.34, the application for a construction permit will contain a preliminary safety analysis report (PSAR) and an environmental report as addressed in 10 CFR 51.50. The application for an operating license (OLA) as described in 10 CFR Part 50, to include submittal of the final safety analysis report and an environmental report as addressed in 10 CFR 51.50 would be predicated on the CPA.

2.0 TECHNOLOGY SUMMARY

The SMR-160 is an advanced, passive, light water nuclear power plant with 160 MW(e) rated net electric output. The SMR-160 is single loop pressurized water reactor (PWR) designed to circulate the reactor coolant through the reactor core and the integrally connected steam generator without reactor coolant pumps. The plant design provides redundant and diverse pathways to reject heat from the core and incorporates existing materials and environmentally qualified components, penetrations, and instruments. SMR-160 is designed to be modular: each reactor unit is entirely autonomous of others at a multi-unit site. Multiple reactor units can be controlled safely from a common control room.

The SMR-160 is designed with a single loop, natural circulation, based on PWR technology. The reactor coolant system (RCS) features an integral primary heat transfer circuit instead of the traditional multi-loop circuit of large PWRs. The basic philosophy of the RCS is to use natural circulation to promote heat transfer from the core to the steam generator, while using



simple, diverse safety systems which employ natural, passive phenomena for emergency core cooling.

The basic design principles used in the design of the RCS are as follows:

- Use natural circulation to provide coolant flow in the RCS
- Eliminate large piping connections
- Eliminate penetrations in the lower two-thirds of the reactor pressure vessel, such that all the penetrations are above the top of active fuel
- Provide ample water above the core to prevent uncovering the core in the event of a LOCA
- Use proven materials for vessel construction
- Design pressure vessels in accordance with ASME B&PV Code

The major components of the RCS include the reactor pressure vessel (RPV), steam generator (SG) with integral pressurizer (PZR), and the reactor coolant startup pumps (RCSP). The offset configuration of the SG and RPV (see Figure 2-1) enables the use of traditional external control rod drive mechanisms and refueling equipment. The SMR-160 PZR is integral to the SG, with an internal divider plate eliminating the need for large surge piping.

To facilitate natural circulation, the elevation difference between the top of the steam generator and the core has been maximized, resulting in a tall column of water (chimney) above the core. With no penetrations in the lower two thirds of the RPV, the water column in the chimney ensures sufficient reactor coolant inventory above the core which always ensures fuel cooling in the event of a LOCA. The RPV is a thick-walled cylindrical pressure vessel with an integrally welded bottom head and a removable flanged top head (see Figure 2-1). The RPV contains fuel assemblies, control rods, instrumentation, and other internals necessary for core support and directing reactor coolant flow. The upper portion of the RPV shell is equipped with a tapered hub, reverse flange. The SG is a vertical shell and tube, once-through steam generator. Hot reactor coolant passes through a riser located in the center of the SG tube bundle and then passes down through tubes to reject thermal energy to the secondary fluid on the shell side. The use of an integral central riser eliminates loop piping typically required for once through steam generators to bring reactor coolant to the top of the tube bundle. The straight SG tubes provide easy access for in-service inspection and tube plugging as needed. The SG removes heat from the RCS during power operation and during initial cooldown after a shutdown or a reactor trip.

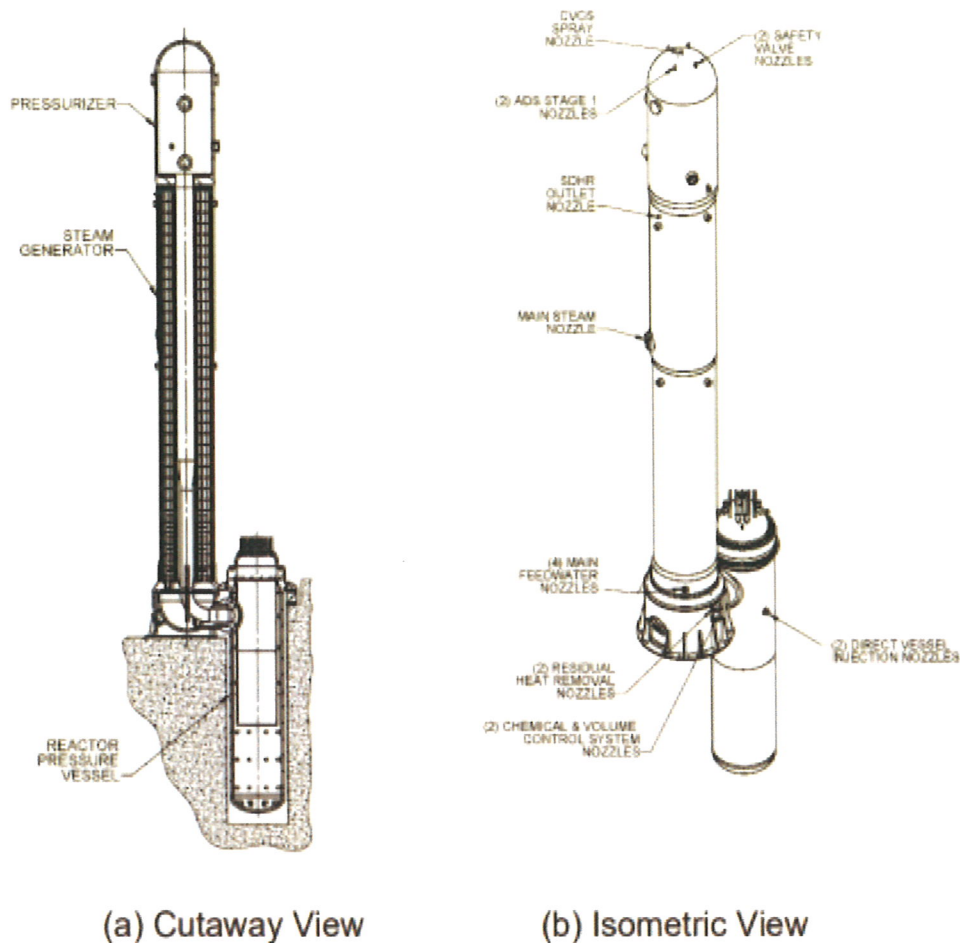

Figure 2-1 Configuration of Combined Vessel

3.0 REP AND PSAR GUIDANCE AND CONTENT

3.1 Selection of Applicable Guidance

Holtec used the following references, in part, for the development of this REP:

- NUREG-0800, Standard Review Plan, Introduction – PART 2 for the Review of Safety Analysis Reports for Nuclear Power Plants: Light-water Small Modular Reactor Edition, Revision 0, 2014
- Regulatory Guide 1.206, Application for Nuclear Power Plants, Revision 1, 2018
- Regulatory Guide 1.70, Standard Format and Content of Safety Analyses Reports for Nuclear Power Plants, Revision 3, 1978
- NEI 18-06, Guidelines for Development of a Regulatory Engagement Plan (REP), Revision 0, 2018



These references inform the content in this REP, and will also be referenced, in part, to support future licensing actions and regulatory decisions as the REP pre-application activities progress.

NUREG-0800 provides the guidance used by NRC staff to perform safety reviews of construction permit or operating license applications under 10 CFR Part 50. While the SRP is not a substitute for the regulations, and compliance is not a requirement, for most application types, the regulation requires an assessment of the facility/design against the SRP in effect six months prior to docketing of the application. The SRP describes review criteria and procedures/methods used by NRC staff to conduct the review. Areas where the review standards are not anticipated to be relevant (e.g., exceptions to review and/or acceptance criteria) to the specific application will be especially important for early engagement and discussion. Regulatory Guide 1.70, like NUREG-0800, describes a standard format and the required content of safety analysis reports for light-water reactors acceptable to NRC staff under 10 CFR 50. RG 1.206 provides additional guidance regarding information to be submitted in a combined license application. All of these references discuss the importance of the REP.

Additionally, Design-Specific Review Standards (DSRSs) are intended to be a design-specific augmentation of the standard review plan (NUREG-0800), adding review criteria where the SRP does not adequately cover the design, or taking exception to SRP criteria where the SRP may not apply to the design. There have been DSRSs developed for other small modular reactors and the general consensus amongst the NRC staff and the industry is that the DSRS effort is a useful concept but is limited in its value because of the natural tension between the need for early identification/resolution of issues and the availability of sufficiently detailed design information to enable the NRC staff to draw final conclusions early enough in pre-application interactions to make binding conclusions in a DSRS. During the pre-application engagement activities, Holtec may consider referencing previous SMR DSRSs to assist in informing the NRC staff's review of specific pre-application topics and elements of the PSAR. See Section 4.1 for selected REP discussion topics.

The content and structure of the PSAR are well-defined by existing NRC regulations and guidance. Holtec will be using the REP pre-application engagement activities to inform the development of the PSAR elements provided in



Table 3-1 below. RG 1.206 format and content instructions are intended for applications developed under 10 CFR 52. RG 1.70 provides instructions for form and content of Safety Analysis Reports for applications developed under 10 CFR 50, but that guidance has not been updated since 1978 and is not consistent with other regulatory guidance. Holtec therefore intends to follow the more contemporary format and content instructions of RG 1.206 and will adjust level of completion to reflect the needs of the Preliminary (construction permit) and Final (operating permit) stages of licensing.



Table 3-1: Proposed PSAR Elements

Ch	RG 1.70	RG 1.206	SMR-160 PSAR
1	Introduction and General Description of Plant	Introduction and Interfaces	Introduction and General Description of Plant
2	Site Characteristics	Site Characteristics and Site Parameters	*Site Characteristics and Site Parameters
3	*Design of Structures, Components, Equipment, and Systems		
4	Reactor		
5	Reactor Coolant System and Connected Systems		
6	Engineered Safety Features		
7	*Instrumentation and Controls		
8	*Electric Power		
9	Auxiliary Systems		
10	Steam and Power Conversion System		
11	*Radioactive Waste Management		
12	Radiation Protection		
13	*Conduct of Operations		
14	Initial Test Program	Initial Test Program and ITAAC	Initial Test Program
15	Accident Analyses	*Transient and Accident Analysis	
16	Technical Specifications		
17	Quality Assurance		
18		Human Factors Engineering	
19		Severe Accidents	PRA and Severe Accident Evaluation
20			Mitigation of Beyond-Design-Basis Events

*Chapter title specifically referenced and discussed in DNRL-ISG-2022-01.

3.2 Principle Design Criteria

10 CFR 50, Appendix A, establishes General Design Criteria (GDC) that are considered the “minimum requirements for principle design criteria (PDC) for water-cooled nuclear power plants similar in design and location to plants for which construction permits have been issued by the Commission.” Part 50.34 requires an application to contain principle design criteria for a construction permit. The PDC establish the “necessary design, fabrication, construction, testing and performance requirements for structures, systems and components important to safety, i.e., structures, systems, and components that provide reasonable assurance that the facility can be operated without undue risk to the health and safety of the public.” Pursuant to Appendix A, the GDC are not necessarily sufficient for all light water designs, and additional criteria may be needed “in the interest of public safety.” Similarly, not all GDC may be necessary or appropriate for a given design, in which case “departures” from the GDC must be identified and justified. In past practice, such departures sometimes have required an exemption. Holtec licensing staff plans to engage the NRC staff on selected PDC during the pre-application engagement process as listed in Section 4.1.



3.3 Use of Standards and Industry Guidance

Consensus standards (ANS, ASME, ANSI, IEEE, etc.) and industry guidance (NEI, EPRI, etc.) will be utilized when appropriate during pre-application activities and the development of the PSAR. These consensus standards and industry guidance will assist in describing various aspects of the SMR-160 design, methodology for design and analysis, siting, etc. Particularly to the extent a given standard has not been endorsed by the NRC staff, or is being used in a novel way, Holtec plans to present the specific information as part of the REP to establish dialog and a common understanding with the NRC staff.

4.0 PRE-APPLICATION ENGAGEMENT

Holtec will facilitate pre-application engagement meetings (teleconferences, videoconferences, and face-to-face) with NRC staff to identify, assess, and mitigate any potential regulatory risks associated with the discussion topics listed in this section. These interactions will also inform the development of the PSAR elements and environmental assessments as part of future application development. The primary benefit planned for this engagement is alignment on the risk-informed content of the topics, and the scope and depth of the NRC review. Holtec will engage in frequent open and closed meetings with NRC staff during these pre-application activities to ensure that NRC staff has timely and accurate information in making safety determinations with respect to agency resource availability. Holtec understands the need to notify the public of agency meetings and will support efforts for early meeting notification. Holtec will also work with the NRC staff to coordinate an appropriate schedule of meetings, taking into account all of the potential attendees.

4.1 Identification of Topics



Table 4-1 below includes topics that have been identified as important to address in pre-application engagements. As the project progresses, Holtec expects that other topics for pre-application engagement may be identified and added to the table below. The NRC will be promptly notified in the event additional topics are added for planning and budgeting purposes. Timely pre-application engagement for each identified topic below will be important to keep the NRC staff informed and aligned on the schedule.



Table 4-1: Topics for SMR-160 Pre-Application Engagement

Topic	Description	Engagement	Approx. Date
REP	Discuss REP content and NRC REP feedback REP Rev 0 – ML22200A252 REP Rev 1 – ML22210A033	Informal Discussion	Jul-2022
LOCA Exemption	Discuss LOCA Questions and Previous Topical Report Submittal	Public Meeting ML22243A010	Aug-2022
Critical Piping	Clarification question on SRP Section 3.6	Informal Discussion	Sep- 2022
CRDS Operability QA Program	Discuss CRDS operability QA program with mechanical group	Public Meeting ML22252A181	Sep-2022
Computer Programs	Clarification question on the use of STAAD.PRO	Informal Discussion	Sep- 2022
Seismic Methodology	Discuss seismic methodology for SRP Section 3.7	Public Meeting ML22259A128	Sep-2022
Instrumentation and Control (I&C)	Discuss an overview of the SMR-160 I&C architecture	Public Meeting ML22263A014	Oct-2022
Spent Fuel Pool (SFP) Makeup Systems	Discuss SMR-160 SFP makeup system compliance	Public Meeting ML22263A380	Oct-2022
Follow-up: CRDS Operability QA Program	Discuss CRDS operability QA program with reactors group	Public Meeting ML22263A420	Oct-2022
Technical Specifications (TSs)	Discuss TSs, specifically the requirements and guidance for TSs in an CPA	Public Meeting ML22297A105	Oct-2022
LOCA Exemption Justification List	Discuss a potential LOCA exemption justification items list	Public Meeting ML22263A388	Oct-2022
Containment Heat Removal System Testing (GDC 40)	Discuss passive containment heat removal system testing and potential exemption	Public Meeting ML22305A691	Nov-2022
Closed System Isolation Valves (GDC 57)	Discuss primary and secondary decay heat removal system closed system isolation valves and potential exemption	Public Meeting ML22307A238	Nov-2022
Various Informal Discussions	Discuss various email topics during the 4Q23.	Informal Discussions	Nov-2022
SECY-94-084 PCCS Safe Shutdown Criteria	Discuss safe shutdown criteria applicable to SMR-160 design	Public Meeting ML22304A131	Dec-2022
SMR-160 Quality Assurance Program	Discuss potential revision to SMR-160 approved Quality Assurance Topical Report (2014)	Public Meeting ML22329A005	Dec-2022
RCS Makeup (GDC 33)	Discuss RCS Makeup (GDC 33) Compliance	Public Meeting	Jan-2023 (1/11/23)
CPA Parts and TOC	Discuss NRC CPA Parts and TOC Expectations	Public Meeting	Jan-2023 (1/25/23)
Instrumentation and Control (I&C)	Discuss I&C Hazard Analysis Methodology	Public Meeting	Feb-2023 (2/8/23)
Chapter 15 Analysis Methods	Discuss accident analysis methods, progress, testing timelines, and expectations. Additionally, discuss questions regarding Appendix K.	Public Meeting	Feb-2023 (2/15/23)
Alternatives for Valve Construction	Discuss licensing Alternatives for Construction of ASME BPVC Section III, Class 1, 2, and 3 Valves	Public Meeting	Feb-2023 (2/22/23)



Topic	Description	Engagement	Approx. Date
Simulator and Operator Training/Qualifications	Discuss the simulator certification process and operator training timelines/expectations	Public Meeting	Mar-2023 (3/8/23)
Environmental Qualification Program	Discuss the EQ Program, questions and clarifications regarding applicable requirements and guidance	Public Meeting	Mar-2023 (3/15/23)
GDC 19 and Cold Shutdown	Discuss GDC 19 Cold Shutdown and applicability to SMR-160 Modes of Operation/TSS	Public Meeting	Mar-2023 (3/22/23)
International Projects	Conduct a discussion with the NRC Office of International Projects (part of a scheduled Holtec drop-in with the EDO and NRC Commission)	Drop-in Visit (Brett Rini & Eric Thomas)	Mar-2023
LOCA Exemption Justification (Update #1)	Quarterly Update to discuss and present SMR-160 LOCA Exemption justification information and progress (LBB Methodology Included)	Public Meeting	Apr-2023 (4/5/23)
Electronic Submittal Process	Discuss the NRC's License Application Electronic Submittal Process and Lessons-Learned	Public Meeting	Apr-2023 (4/19/23)
SMR-160 Design Overview	Discuss and present a high-level design overview of the SMR-160 to the NRC staff	Public Meeting	Apr-2023 (4/26/23)
Fuel Qualification and Testing	Discuss the SMR-160 fuel qualification and testing plan	Public Meeting	May-2023
LOCA Exemption Justification (Update #2)	Quarterly Update to discuss and present SMR-160 LOCA Exemption justification information and progress	Public Meeting	Jun-2023
Instrumentation and Control (I&C)	Discuss I&C D3 assessment and coping analysis	Public Meeting	Jul-2023
Instrumentation and Control (I&C)	Discuss I&C unit bus design, bidirectional communication and system independence	Public Meeting	Aug-2023
Readiness Assessment	Discuss the NRC readiness assessment process	Public Meeting	Aug-2023
LOCA Exemption Justification (Update #3)	Quarterly Update to discuss and present SMR-160 LOCA Exemption justification information and progress	Public Meeting	Sep-2023
<i>Additional Items TBD</i>			



4.2 Types and Frequency of Interactions

The type and frequency of interactions with the NRC will be managed by Holtec licensing staff and coordinated with the SMR project team and the NRC staff. The number and frequency of these interactions will be key to maintaining a consistent understanding of the status of issue identification and resolution. These interactions will include frequent phone calls, emails, teleconferences, meetings to solicit feedback on proposed technical approaches, review of technical reports and white papers, audits of engineering information and potential inspections of testing facilities that support the pre-application engagement topics and PSAR development.

Holtec is proposing the following meetings with NRC staff:

- bi-monthly (every 2 weeks) meeting with NRC project managers and technical reviewers
- quarterly status that describes accomplishments, progress, remaining outstanding items and additional areas of focus to assess the status of the pre-application engagement
- planning meetings and drop-ins, as needed

In addition, with respect to the pre-application engagement topics presented in



Table 4-1, Holtec proposes engaging with the NRC in the following manner for each topic:

- Conduct pre-submittal meetings with the NRC for a selected topic, typically a remote session with presentation materials describing expectations (including a potential schedule and budget) for the associated review
- Submit white paper or technical report on the selected topic presented to provide material for the NRC staff's review
- Receive feedback from NRC staff regarding alignment on expectations, allocated resources, budget and schedule for the review of the selected item
- Hold a post-review meeting with the NRC staff to obtain feedback (the format of this should be agreed on between Holtec licensing and NRC staff, and may be in the form of a phone call or another informal method of interaction)

Prior to and following the submittal of white papers or technical reports for the selected pre-application engagement topics, routine and frequent interaction is expected via phone and email between the NRC and Holtec. The communication plan and interaction frequency listed below should be initiated and can be amended as necessary to support healthy communications and common understanding of the status of all the pre-application engagement activities:

- Monthly calls between NRC Director, Division of New and Renewed Licenses (DNRL) and Holtec Vice Presidents of Licensing and SMR Reactor Technologies
- Bi-weekly, or more frequent, calls established between the NRC Branch Chief, New Reactor Licensing Branch (NRLB) and Holtec Director, SMR Licensing
- Weekly, or more frequent, calls established between the assigned NRC project manager (PM) and Holtec Director, SMR Licensing, or designated SMR Licensing Engineer.

Periodic drop-in visits and meetings, between Holtec and NRC staff (which may include participation by various levels of Holtec and NRC management) will be conducted to exchange general information on nontechnical topics such as planning for future interactions, and status/schedule updates. Limited discussion of technical issues can occur, but typically it will be in the context of status of review or identification of topics for separate discussion.

4.3 Technical Discussions and Written Submittals

Initial discussions between Holtec and NRC staff will be concerned primarily with the planned strategies for development of the PSAR. Topics for these discussions, as well as follow-up interactions, will be developed by the Holtec Director, SMR Licensing, and shared with the NRC staff and may focus on individual topics or several topics combined for efficiency.



Written submittals will be provided on the docket, including white papers, presentations, and technical reports. White papers will be utilized to present information and describe positions on a specific topic with the objective of increasing understanding and seeking alignment with NRC staff. The use of white papers will be employed to address high level issues, summarize proposed approaches, and seek clarification on methodologies, guidance and technical issues. To ensure clarity with respect to the use, application and review of all written submittals (white papers and/or technical reports) during preapplication activities, frequent communication between Holtec and NRC staff will be conducted as detailed above. Early in the pre-application engagement process, Holtec and the NRC staff will need to align on how white papers and technical reports will be incorporated in the PSAR, either by reference or summarized.

4.4 Information Sharing and the Potential Escalation of Issues

A Holtec electronic reading room will be established to allow Holtec to share documents with the NRC staff, including program procedures, presentations, drawings, white papers, and technical reports. A more detailed discussion of the electronic reading room and online reference portal information access agreement can be found in the NRC Agencywide Documents Access and Management System (ADAMS) under ML22215A031 dated August 23, 2022.

As part of the pre-application activities, it may be necessary to resolve conflicts between existing regulatory infrastructure and new features in the SMR-160 design. Early identification and appropriate escalation of the issues will be useful in ensuring a timely resolution. Holtec licensing staff will work with the NRC staff to resolve these issues early in the process and at the appropriate level. As the REP is updated and expanded throughout the pre-application activities, Holtec may reassess any issues and/or conclusions reached in previous discussions to identify needed exemptions from NRC regulations and/or deviations from regulatory guidance.

4.5 Schedule Considerations

Preapplication:

- Initial pre-application drop-in meeting – 5/7/22 (Completed)
- Teams meeting to present the proposed REP – 7/21/22 (Completed)
- Routine interactions between Holtec and the NRC staff commences (as discussed in Section 4.2) (Proposed)
- First presentation and review topic for pre-application engagement – Week of 10/3/22 (Proposed)

Additional presentations and review topics will follow the list in



- Table 4-1

Pre-application engagement activities will establish a schedule of meetings and submittals as well as the timing and duration of NRC staff reviews, as discussed above. Additionally, the expectations for communicating changes to the schedule and/or scope will be established. Any potential program audits and inspections will be coordinated with the NRC staff.

5.0 OTHER TOPICS

5.1 Readiness Assessment Audit and Application Submittal

A readiness assessment audit should occur with sufficient time to resolve any identified issues prior to the submittal an application. Holtec may request that the NRC staff conduct a readiness assessment audit of the completed, or nearly completed draft PSAR. This readiness assessment is a comprehensive review of the material over several days. The conclusion of the audit is a series of observations by the NRC staff, focusing on issues that might preclude acceptance of the material, if left unresolved or uncorrected. A secondary objective of the readiness assessment audit is to identify areas for which clarifications or supplemental information could preclude or minimize staff requests for additional information. Depending on the complexity and results of the various pre-application engagement activities and reviews discussed above, the schedule for submittal of a PSAR may change which may warrant an update to the REP or may be communicated through more routine discussions between Holtec and NRC staff.

5.2 Budget

Budgeting considerations is an important consideration in establishing and maintaining the pre-application engagement schedule. Estimated NRC staff review fees, including review hours, will be estimated at the time the selected topic is presented for review and monitored on an ongoing basis. Both Holtec and NRC staff will communicate any expected changes in the level of estimated NRC staff review fees, resource availability, or funding restrictions. The Holtec budget estimate for each topic listed for review in



Table 4-1 will be in the range of 70 – 100 hours.

6.0 REFERENCES

- [1] Nuclear Energy Institute (NEI) 18-06, Guidelines for Development of a Regulatory Engagement Plan (REP), Revision 0, 2018
- [2] NUREG-0800, Standard Review Plan (SRP), Introduction – PART 2 SRP for the Review of Safety Analysis Reports for Nuclear Power Plants: Light-water Small Modular Reactor Edition, Revision 0, 2014
- [3] Regulatory Guide 1.206, Application for Nuclear Power Plants, Revision 1, 2018
- [4] Regulatory Guide 1.70, Standard Format and Content of Safety Analyses Reports for Nuclear Power Plants, Revision 3, 1978
- [5] NEI white paper, “Issue Escalation Process (Model for ROP Task Force),” (ADAMS Accession No. ML20017A089), dated January 13, 2020
- [6] DNRL-ISG-2022-XX, Safety Review of Light-Water Power-Reactor Construction Permit Applications, Draft Interim Staff Guidance (ML21165A157)
- [7] DRAFT Pre-application Engagement to Optimize Advanced Reactors Application Reviews, May 2021 (ML21145A106)

7.0 LIST OF APPENDICES

None.