

**ENGINE SYSTEMS, INC.**175 Freight Road
Rocky Mount, NC 27804Telephone: 252/977-2720
Fax: 252/446-1134**TELEFAX**

Date: November 24, 2021
Company: NRC Operations Center
Fax Number: 301/816-5151
Verification No.: 301/816-5100
Reference: Report No. 10CFR21-0133, Rev. 0
From: Dan Roberts
Page: 1 of 6

Dear Sir / Madam:

Following this cover is a copy of our report 10CFR21-0133, Rev. 0, for a 10CFR21 reportable notification on a swing check valve, P/N ESI50359.

A copy of this report will be mailed to the NRC Document Control Desk and to our affected nuclear customers.

Should you have questions, please let us know.

Sincerely,

ENGINE SYSTEMS, INC.

Dan Roberts
Quality Manager

**ENGINE SYSTEMS, INC.**

175 Freight Road, Rocky Mount, NC 27804

Telephone: 252/977-2720

Fax: 252/446-1134

Report No. 10CFR21-0133

Rev. 0: 11/24/21

**10CFR21 REPORTING OF DEFECTS
AND NON-COMPLIANCE**

COMPONENT: Swing Check Valve, P/N ESI50359

SYSTEM: Emergency Diesel Generator

CONCLUSION: Reportable in Accordance With 10CFR21

Prepared By: _____

Justin
Engineering Manager

Date: _____

11/24/21

Reviewed By: _____

Dan Robert
Quality Manager

Date: _____

11/24/21

Report No. 10CFR21-0133

Record of Revisions

Page: 1 of 1

REV	DATE	PAGE	DESCRIPTION
0	11/24/21		Original Issue.

Report No. 10CFR21-0133
Revision: 0
Date: 11/24/21
Page: 1 of 3

Pursuant to 10 CFR 21.21(d)(4), ESI is presenting the required information as follows:

- (i) Name and address of the individual or individuals informing the Commission.

*Dan Roberts
Quality Manager
Engine Systems Inc.
175 Freight Rd.
Rocky Mount, NC 27804*

*John Kriesel
Engineering Manager
Engine Systems Inc.
175 Freight Rd.
Rocky Mount, NC 27804*

- (ii) Identification of the basic component supplied within the United States which fails to comply or contains a defect.

Swing Check Valve, P/N ESI50359

- (iii) Identification of the firm supplying the basic component which fails to comply or contains a defect.

Engine Systems Inc. (ESI)

- (iv) Nature of the defect or failure to comply and the safety hazard which is created or could be created by such defect or failure to comply.

The hinge pin retainer plug used on check valve P/N ESI50359 may exhibit low breakaway torque and thus minimal resistance to loosening when subjected to engine operating vibrations. Consequently, if the plug were to completely dislodge, followed by the associated hinge pin, the pressure boundary of the lube oil system would be compromised and oil would discharge through the 3/16" diameter opening. ESI was notified by a nuclear customer of such an occurrence on a check valve that had been recently installed. Following notification, ESI inspected remaining check valves in inventory and confirmed an issue where the plug exhibited low breakaway torque that could potentially lead to unintended loosening.

P/N ESI50359 is a 1/2" female NPT, stainless steel swing check valve used specifically for EMD engine applications in the gallery fill line between the lube oil cooler and main engine pressure pump discharge elbow. During standby conditions, the valve allows forward flow of heated lube oil to the engine. During engine operation, the valve closes to prevent reverse flow of main lube oil. The plug retains the hinge pin within the valve and utilizes straight threads, thus requiring a sealing washer. The material of the sealing washer is PTFE. Due to the relatively soft nature of the PTFE and small surface area, the applied torque must be minimized to prevent deformation or extrusion. These factors, in conjunction with the relatively low friction coefficient of PTFE, lead to a low breakaway torque and the potential for loosening. See Figure 1 & 2 below for a visual depiction of the swing check valve. Figure 3 on the following page shows a typical installation.

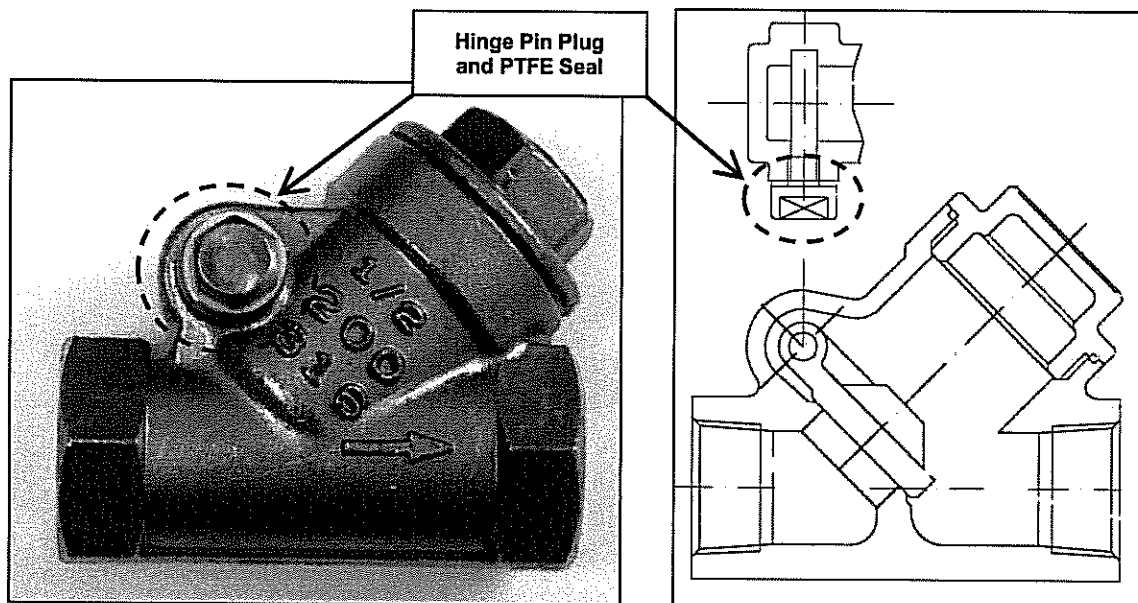

Figures 1 & 2: View of Swing Check Valve P/N ESI50359

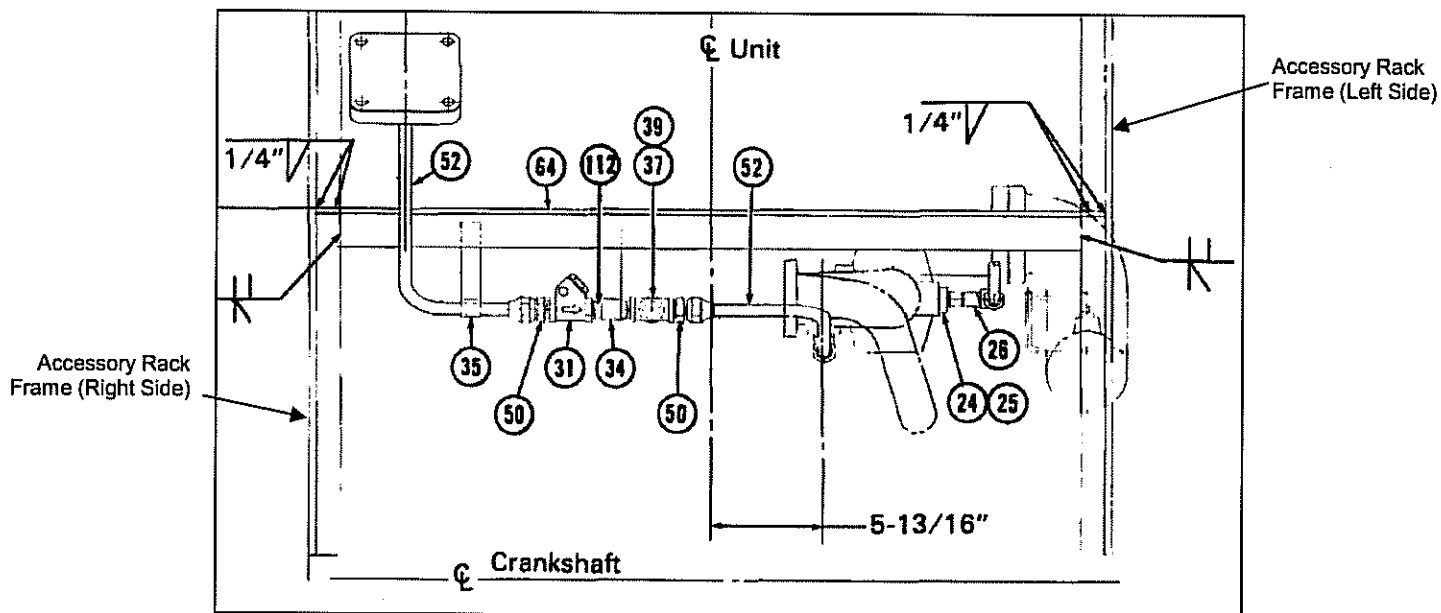

Figure 3: Typical Check Valve Installation (item 31 shown)

(v) The date on which the information of such defect or failure to comply was obtained.

November 9, 2021

(vi) In the case of a basic component which contains a defect or fails to comply, the number and location of these components in use at, supplied for, being supplied for, or may be supplied for, manufactured, or being manufactured for one or more facilities or activities subject to the regulations in this part.

Part Number	Customer	Customer PO	Qty Shipped	C-of-C Date	ESI Order
ESI50359	Tennessee Valley Authority - Brown's Ferry	5947631	9	01/10/20	3020300
	Exelon - Dresden	00000703-13313	3	01/29/20	3020381
	Tennessee Valley Authority - Brown's Ferry	6005163	2	02/10/20	3020391
	First Energy Corp - Beaver Valley	45560499	1	03/02/20	3020181
	Exelon - Dresden	00000703-13326	1	03/02/20	3020484
	Dominion Virginia Power - Surry Power Station	4500597920	3	07/08/20	3020651
	Exelon - Dresden	726302	1	06/01/20	3020719
	Energy Harbor Corp - Beaver Valley	45656635	1	04/01/21	3021639
			1	04/05/21	
			1	04/15/21	
Tennessee Valley Authority - Brown's Ferry	6879386	10	10/01/21	3022282	

Table 1: List of Customers for P/N ESI50359

Report No. 10CFR21-0133
Revision: 0
Date: 11/24/21
Page: 3 of 3

- (vii) The corrective action which has been, is being, or will be taken; the name of the individual or organization responsible for the action; and the length of time that has been or will be taken to complete the action.

For all affected customers:

ESI recommends a rework of the check valve. Remove the hinge pin retainer plug and ensure plug threads and PTFE washer are free from damage or distortion. Apply Loctite 243 sparingly to clean plug threads then re-install the plug and PTFE washer, using caution to minimize seepage of thread locker. Using a 10mm socket, torque the plug to 5 (± 0.5) in-lbs and allow the Loctite to cure.

Note: *For check valves installed on the engine, this activity should be performed with urgency. It is difficult to predict if the plug will loosen but the issue detected by the customer occurred within 2 hours of operation. Since inspections of other check valves detected low breakaway torque, this indicates plug loosening to be a likely scenario when the valve is subjected to engine operating vibrations. As a reminder, the circulating oil pump must be turned off and oil drained from the line prior to performing rework.*

For ESI:

The dedication procedure for this check valve is currently undergoing revision to incorporate the rework activity listed above (use of Loctite 243 and 5 in-lb torque). This will eliminate unintended plug loosening from future shipments. This is expected to be complete by December 7, 2021 and in all cases, prior to any future shipments.

- (viii) Any advice related to the potential defect or failure to comply about the facility, activity, or basic component that has been, is being, or will be given to purchasers or licensees.

N/A