

CORE FLOW (% RATED)

(Rev. 12 1/03)



PERRY NUCLEAR POWER PLANT

Typical Design Power/Flow Map
Standard Power/ Flow Region

Figure 15.0-1

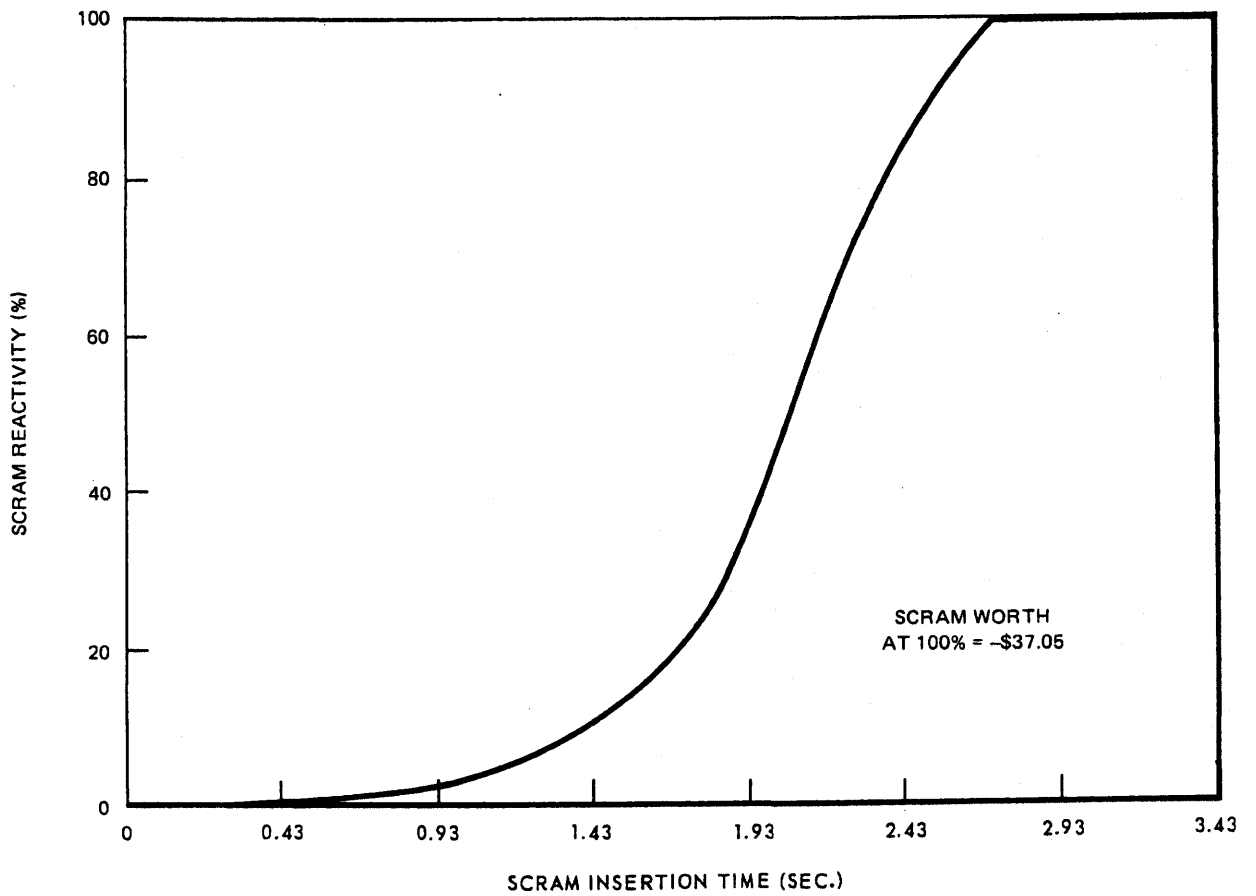

(Rev. 12 1/03)



PERRY NUCLEAR POWER PLANT

Scram Reactivity Characteristics
(REDY)

Figure 15.0-2

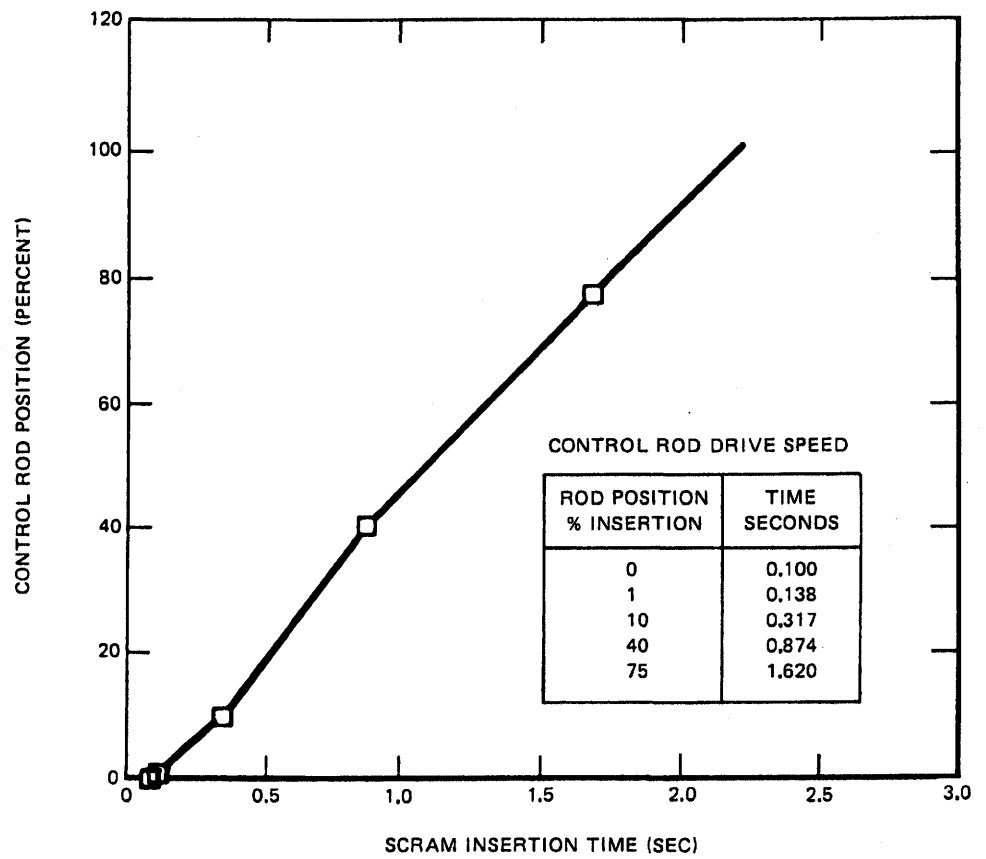

85-424-01

(Rev. 12 1/03)



PERRY NUCLEAR POWER PLANT

Scram Time Characteristics

Figure 15.0-3

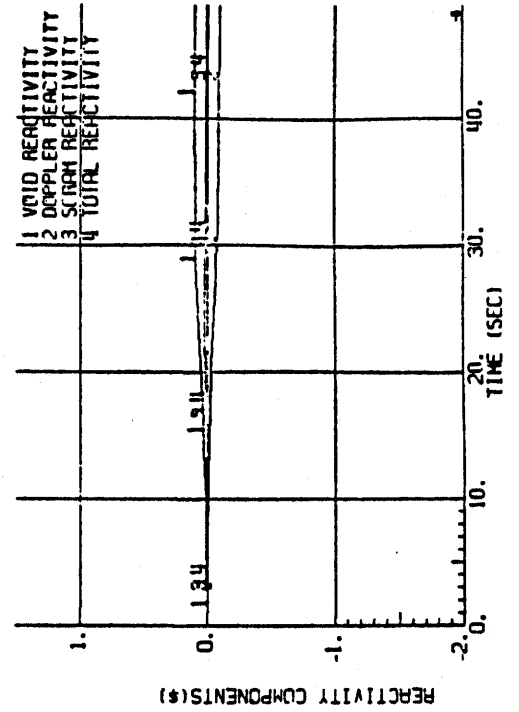
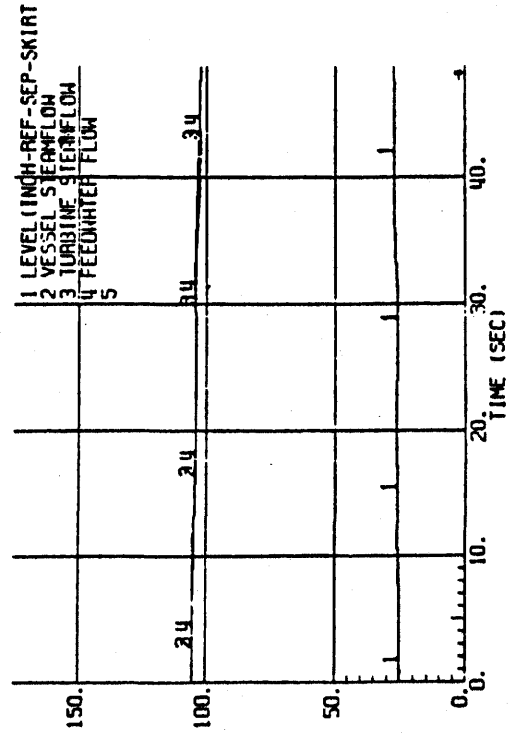
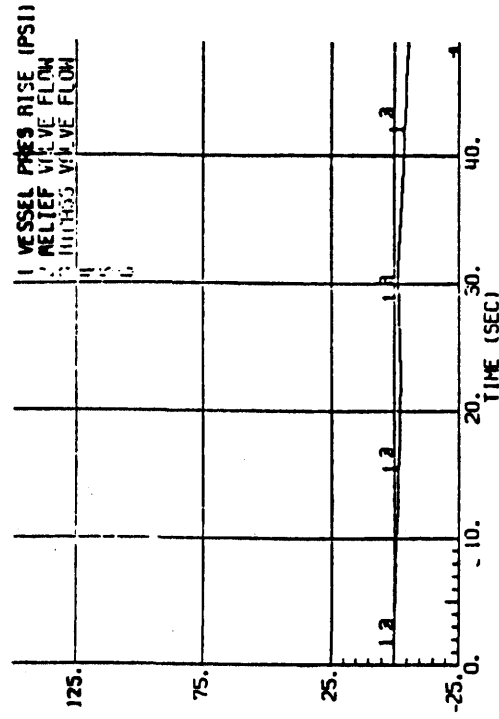
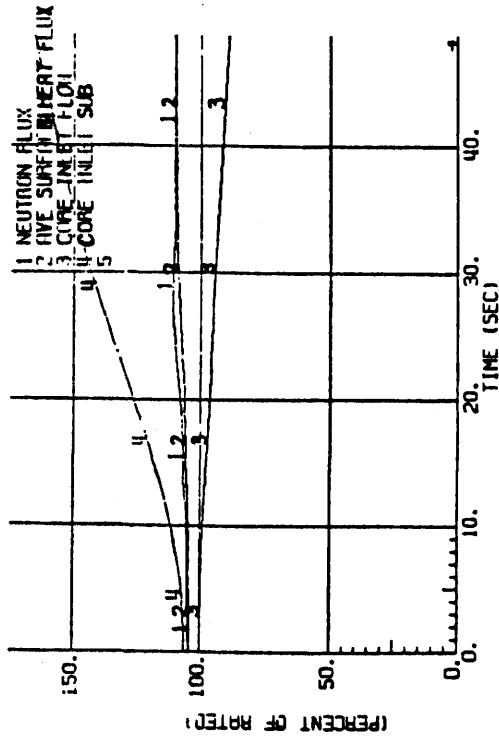

(Rev. 12 1/03)



PERRY NUCLEAR POWER PLANT

Loss of 100°F Feedwater Heating,
Automatic Flow Control

Figure 15.1-1

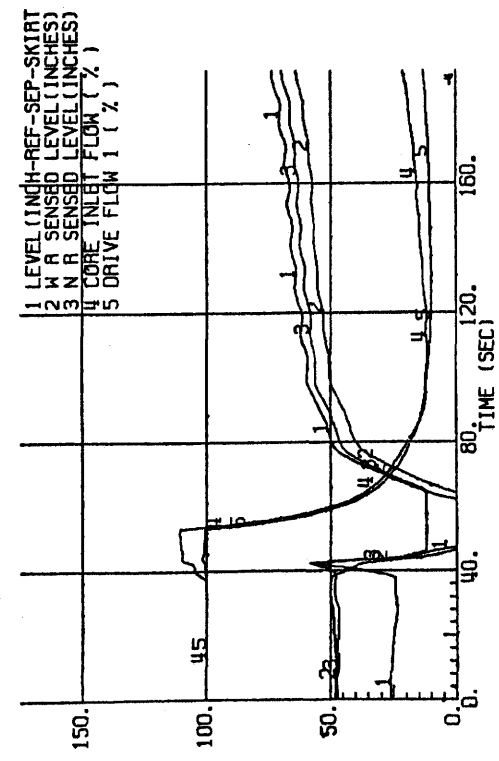
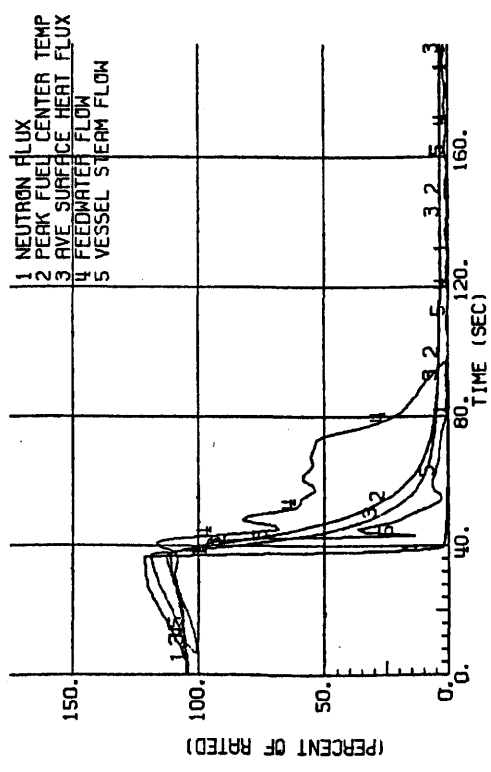
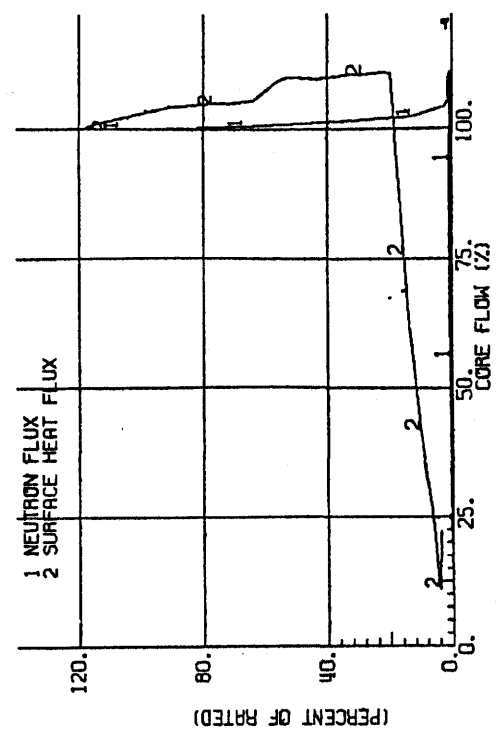
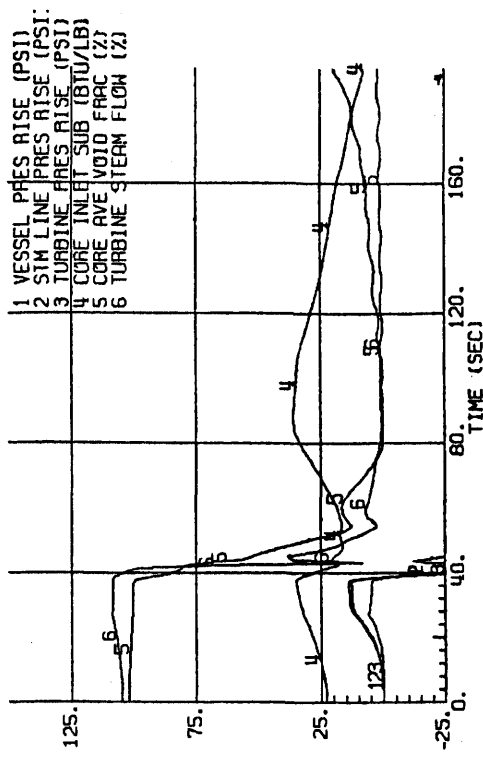

(Rev. 12 1/03)

PERRY NUCLEAR POWER PLANT

Loss of 100°F Feedwater Heating,
Manual Flow Control

Figure 15.1-2

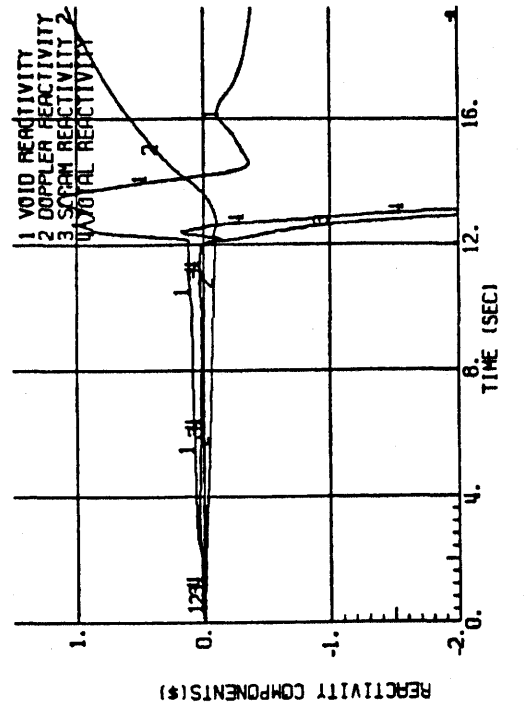
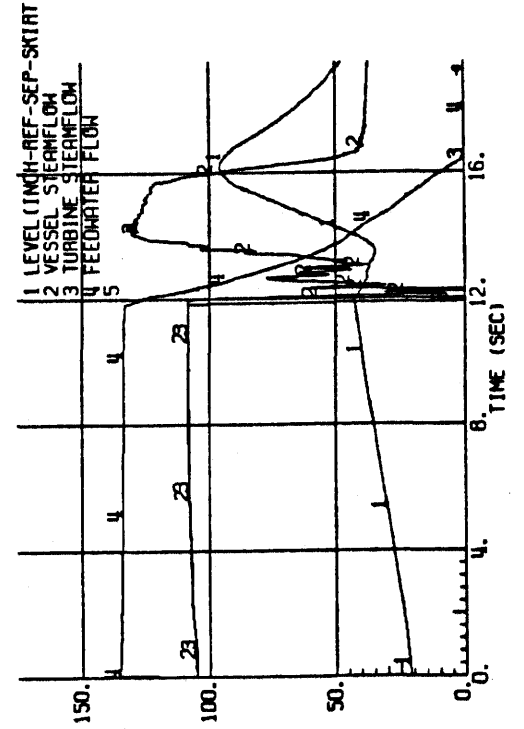
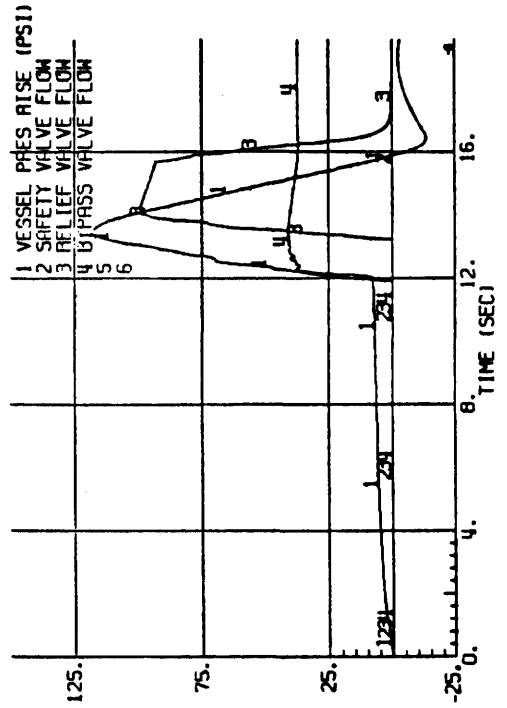
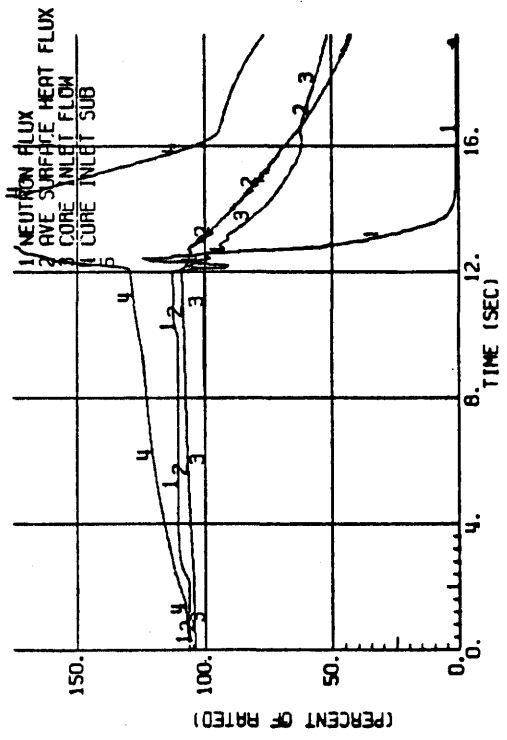

(Rev. 12 1/03)

PERRY NUCLEAR POWER PLANT

Feedwater Controller Failure,
Maximum Demand, With
HWL Trips

Figure 15.1-3

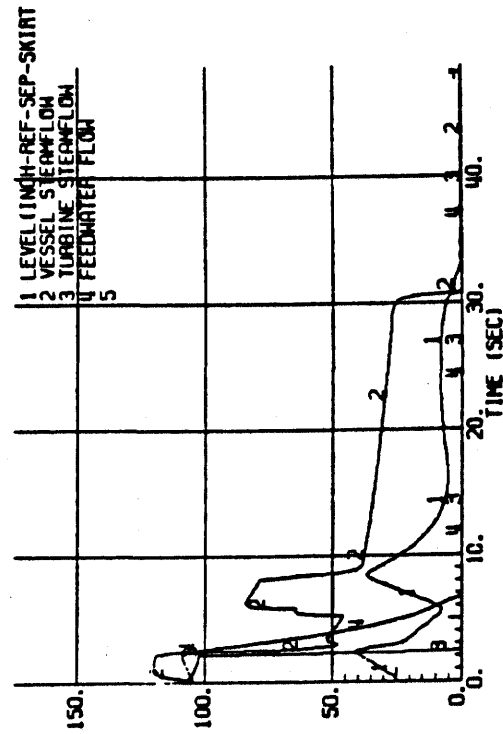
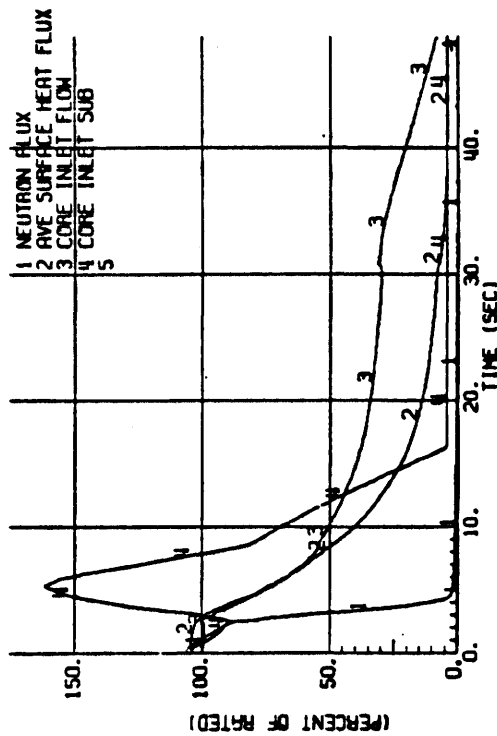
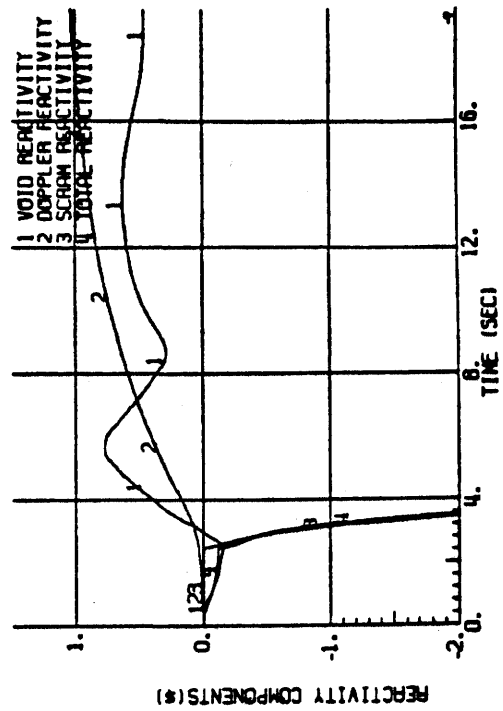
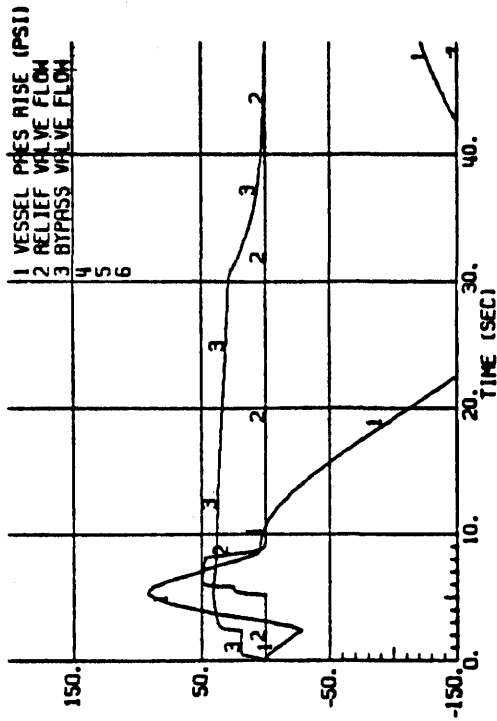

(Rev. 12 1/03)



PERRY NUCLEAR POWER PLANT

Pressure Regulator Failure -
Open to 130%

Figure 15.1-4

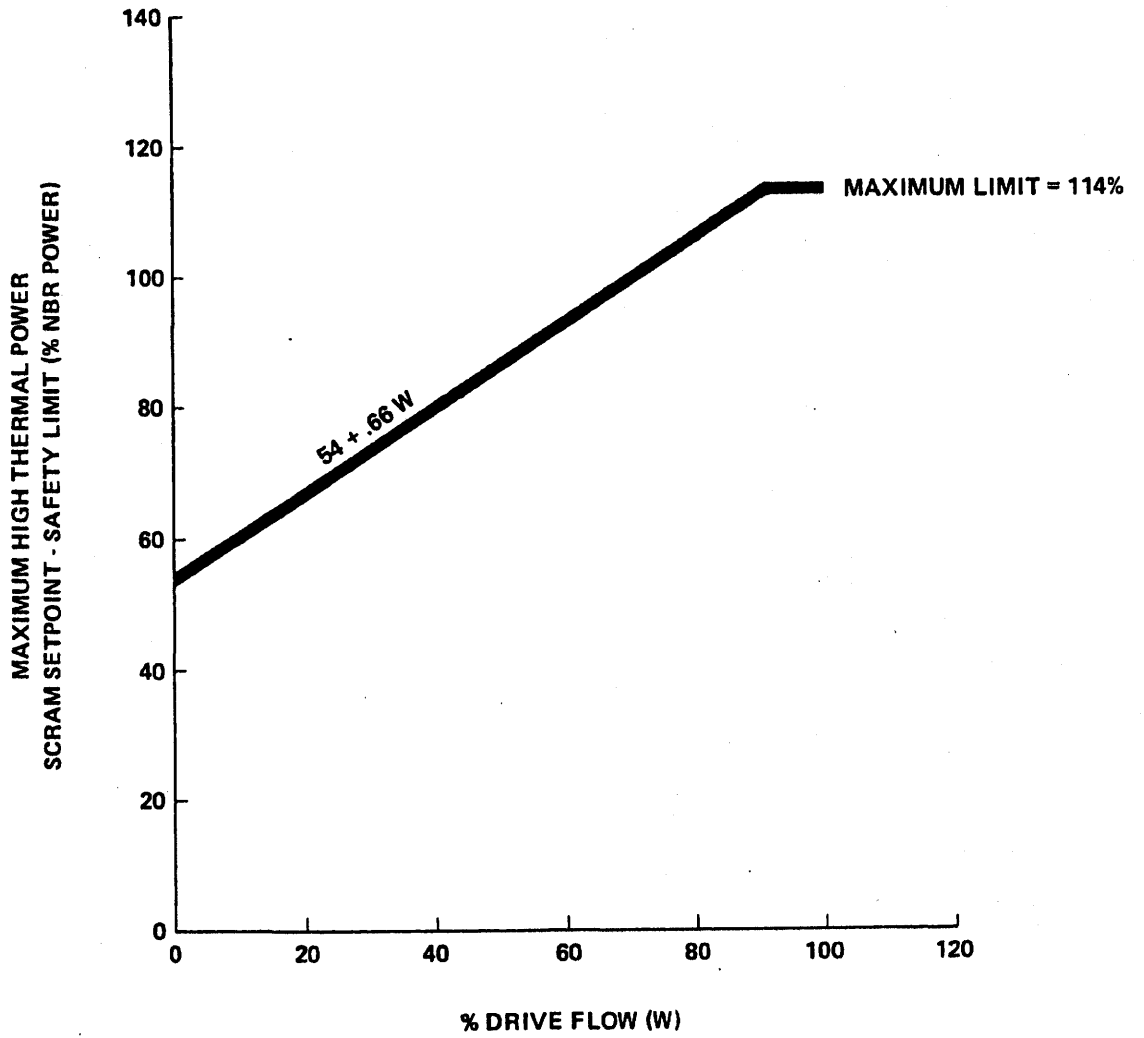

(Rev. 12 1/03)



PERRY NUCLEAR POWER PLANT

High Thermal Power Scram
Setpoint for Plant Operation
up to 100% NBR Power

Figure 15.1-5

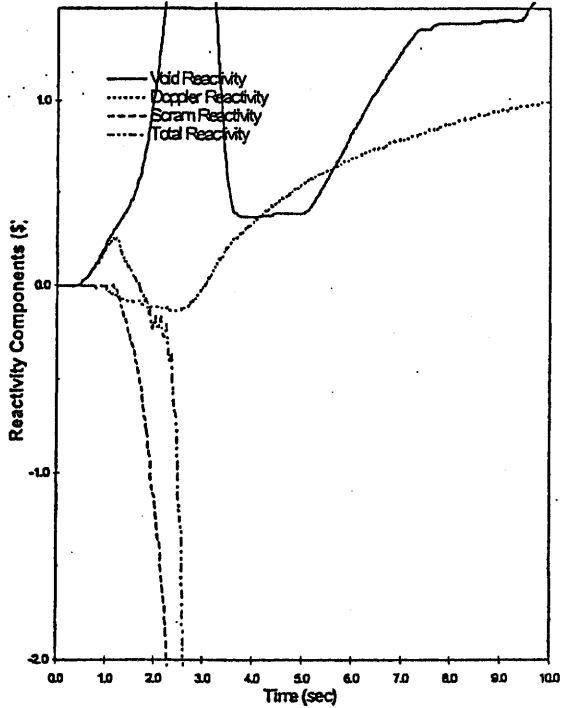
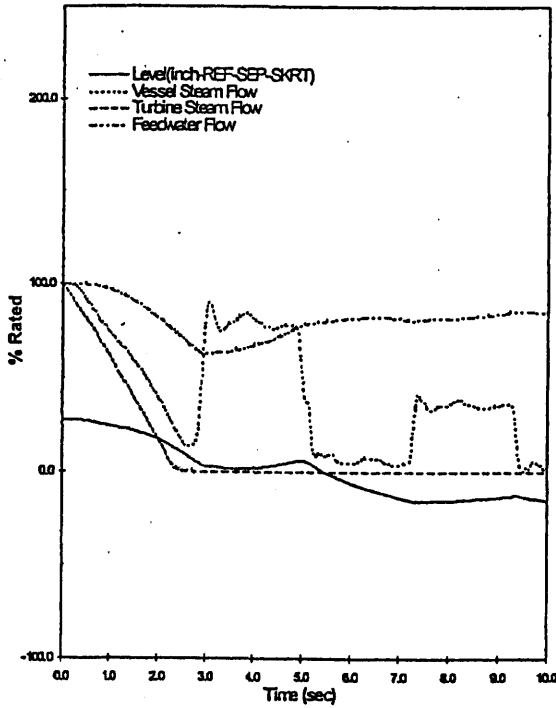
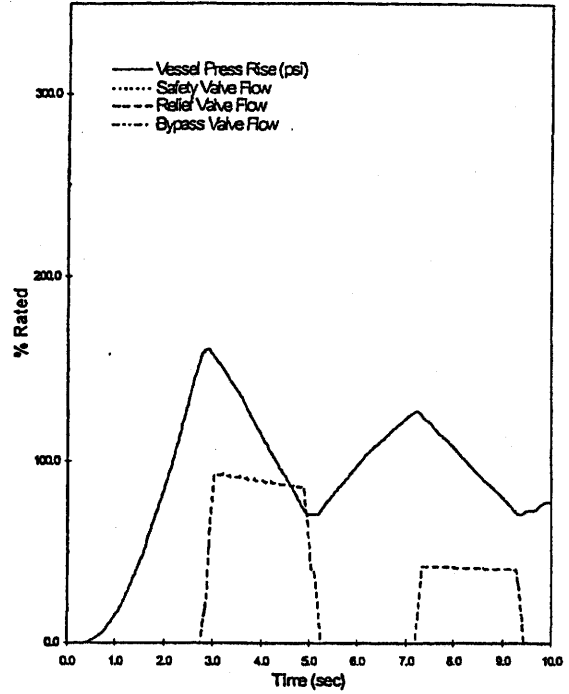
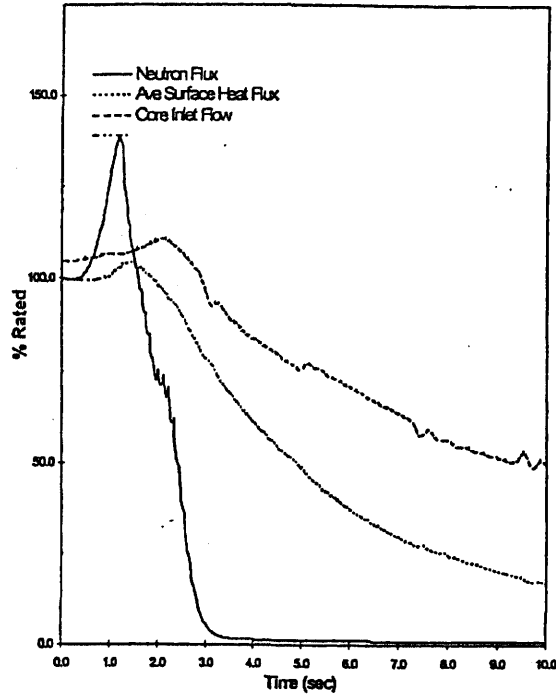

(Rev. 12 1/03)

PERRY NUCLEAR POWER PLANT

Pressure Regulator Downscale
Failure

Figure 15.2-1

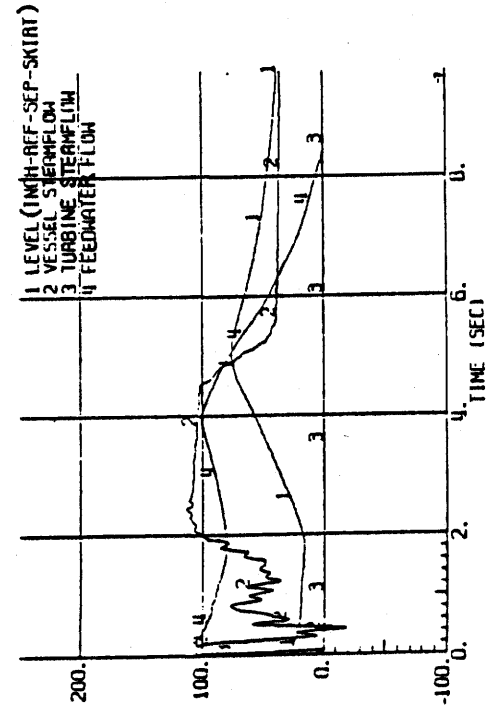
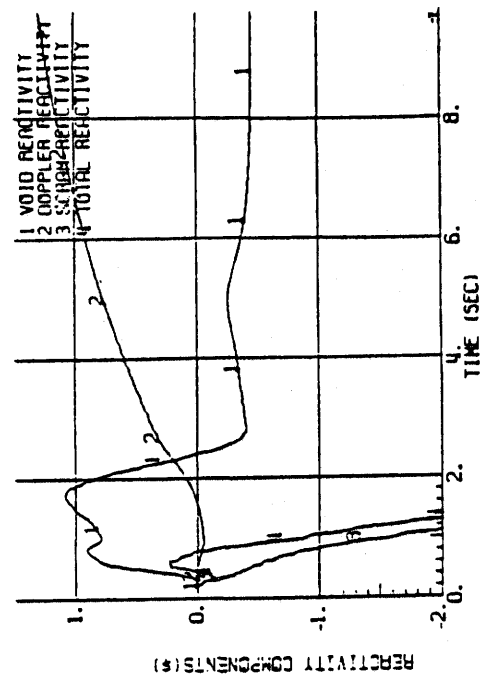
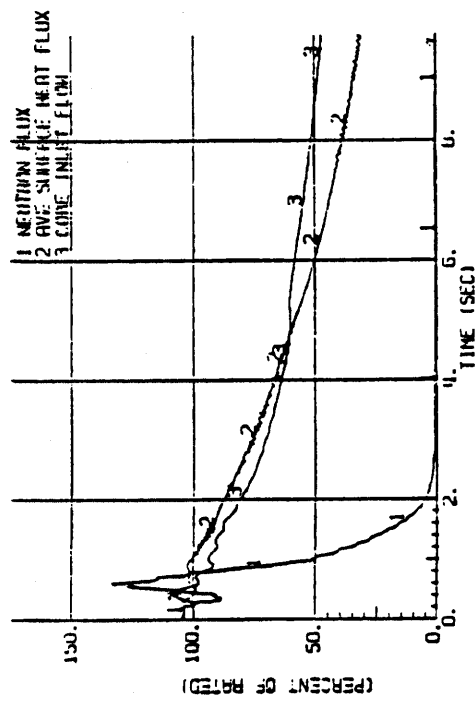
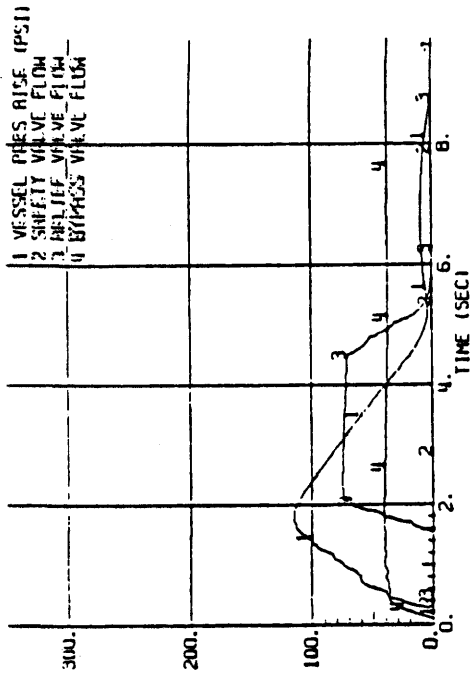

(Rev. 12 1/03)



PERRY NUCLEAR POWER PLANT

Generator Load Rejection
 Trip Scram, Bypass - On

Figure 15.2-2

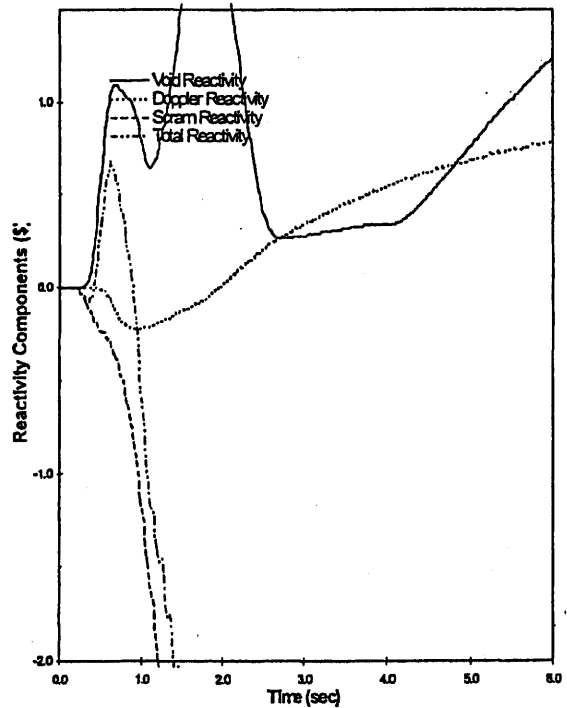
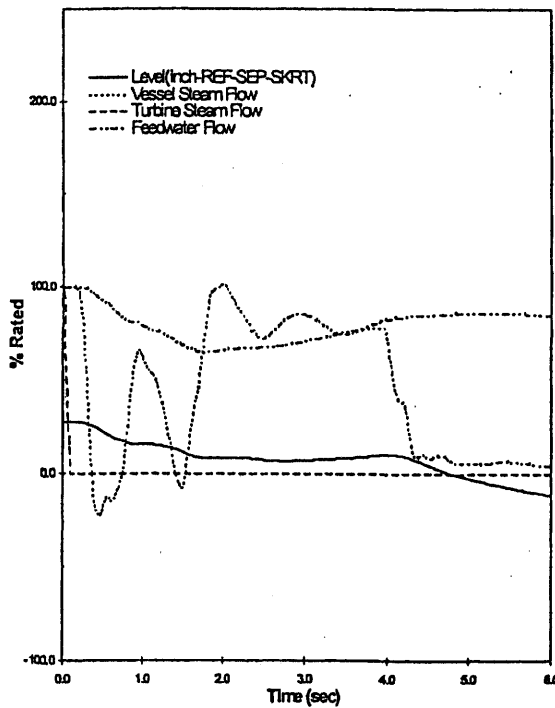
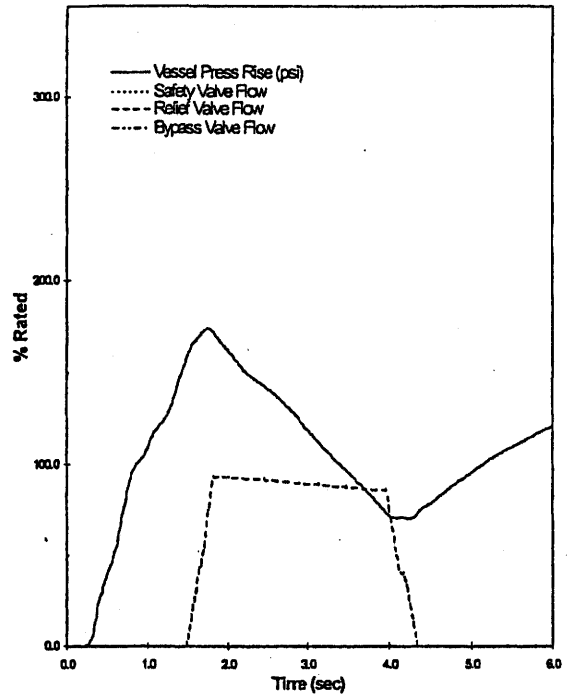
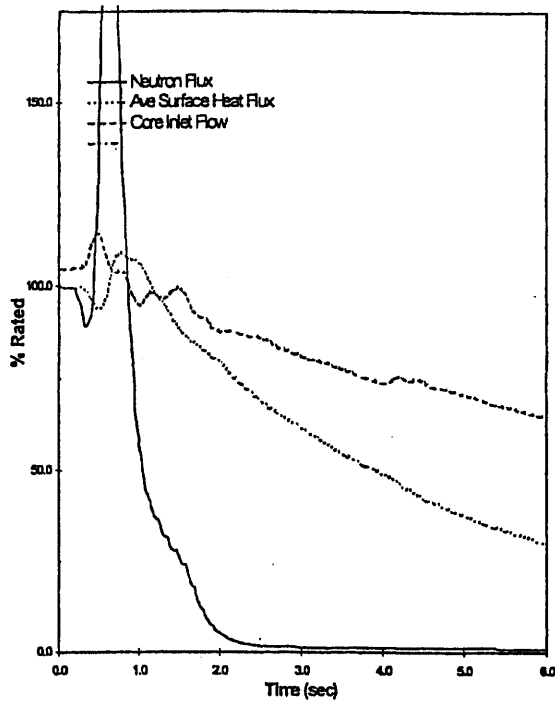

(Rev. 12 1/03)



PERRY NUCLEAR POWER PLANT

Generator Load Rejection
 Trip Scram, Bypass - Off

Figure 15.2-3

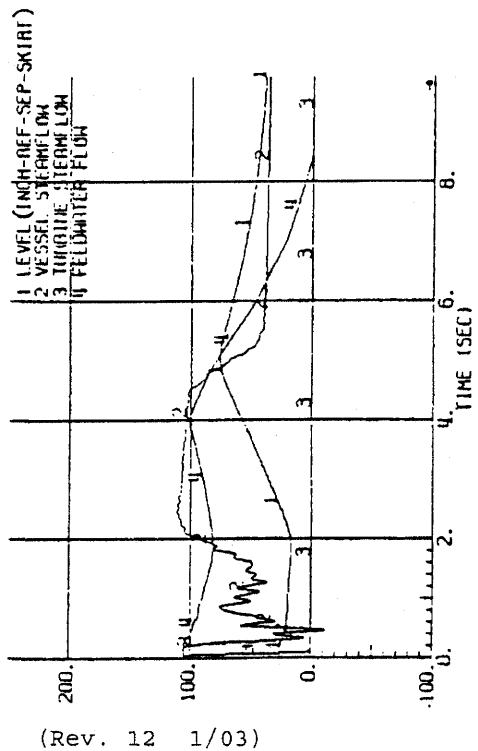
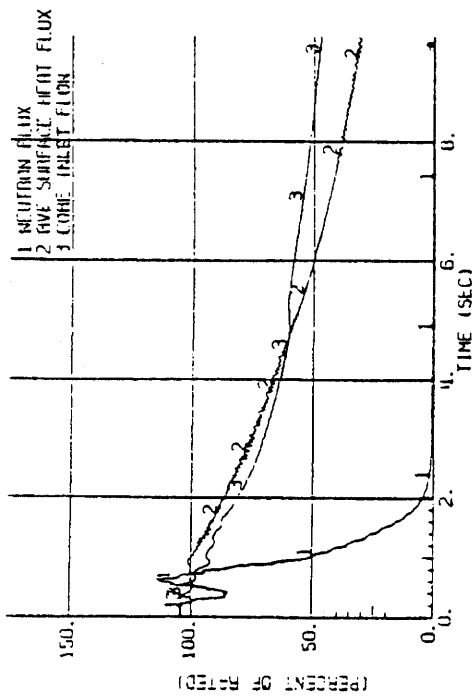
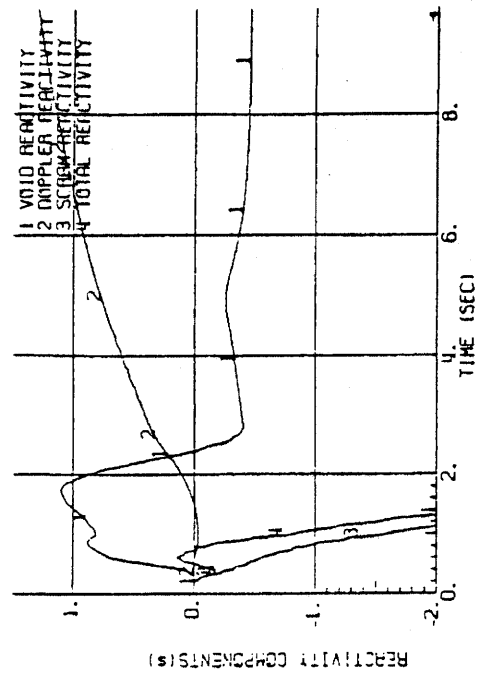
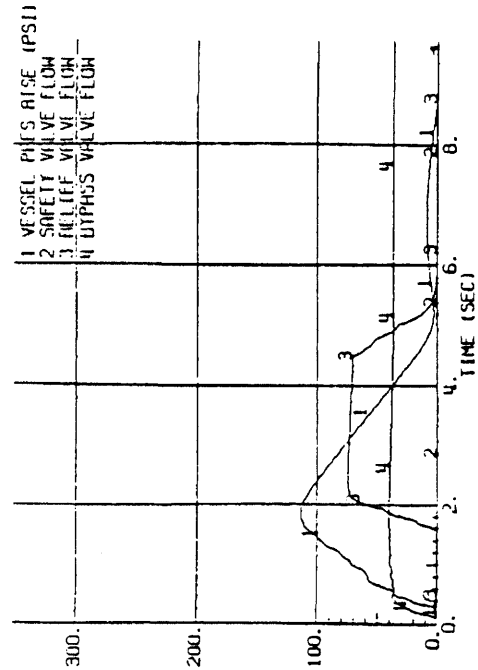

(Rev. 12 1/03)



PERRY NUCLEAR POWER PLANT

Turbine Trip, Trip Scram,
Bypass and RPT - On

Figure 15.2-4

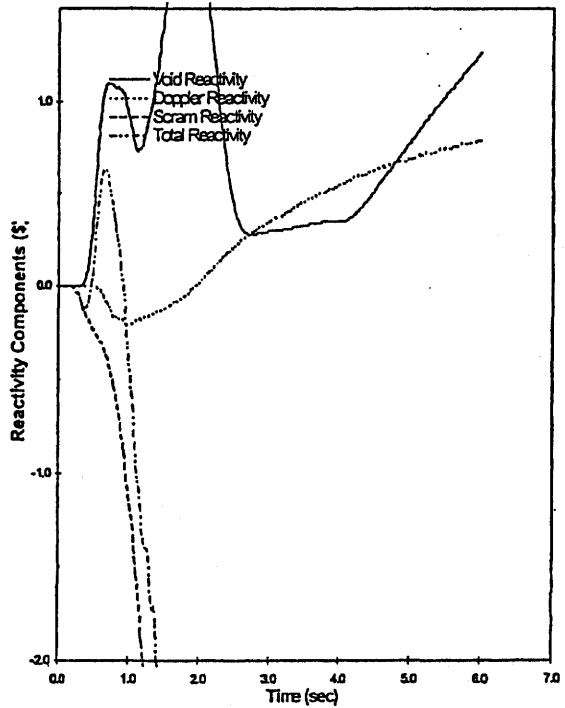
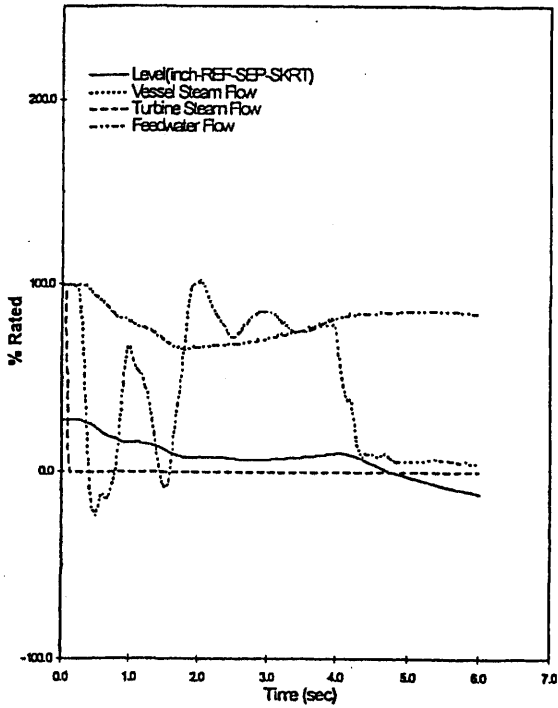
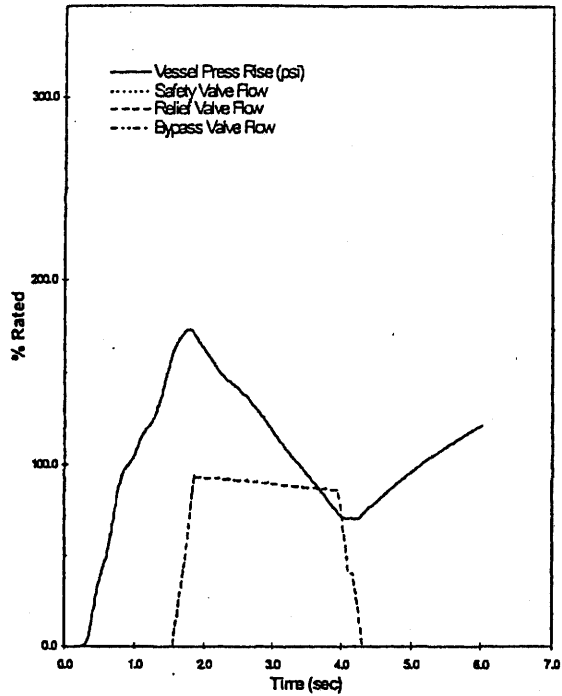
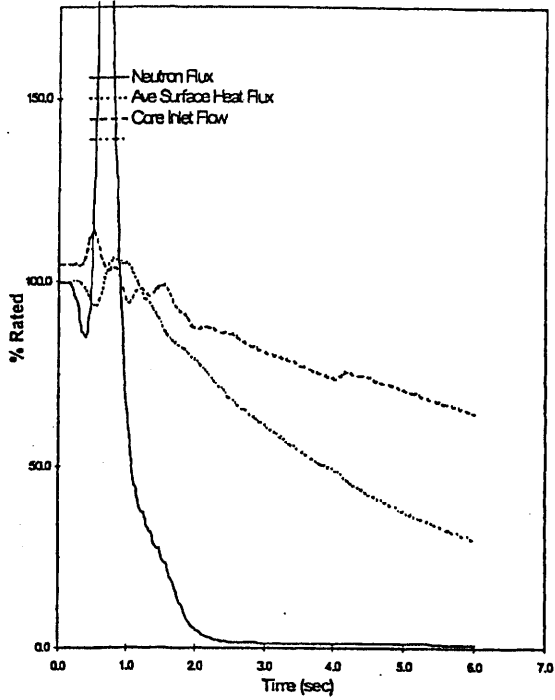

(Rev. 12 1/03)



PERRY NUCLEAR POWER PLANT

Turbine Trip, Trip Scram,
Bypass - Off, RPT - On

Figure 15.2-5

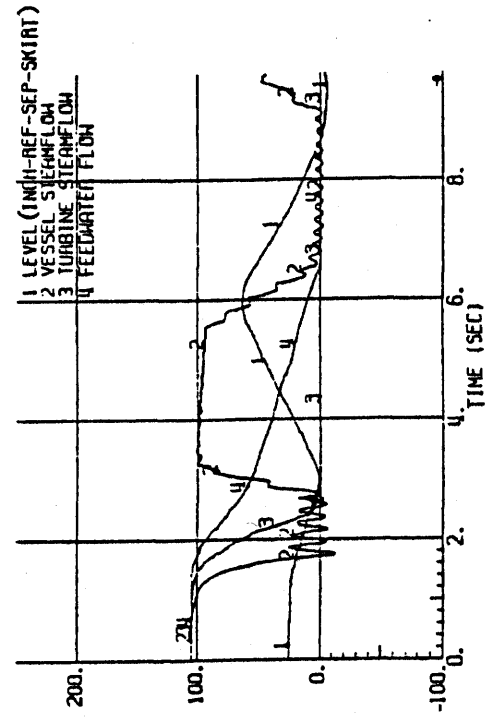
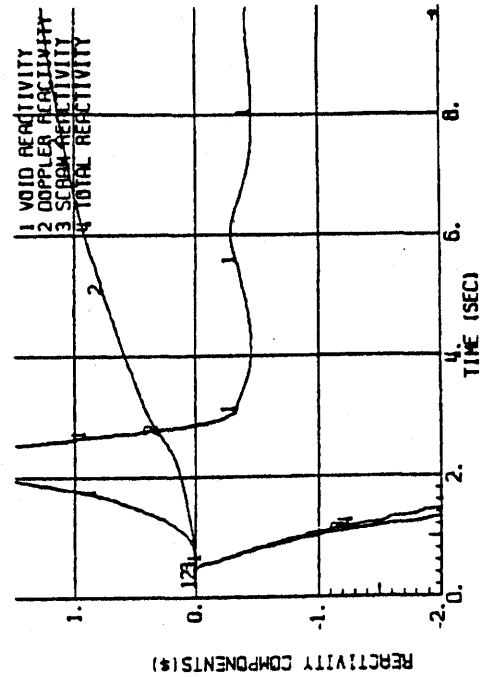
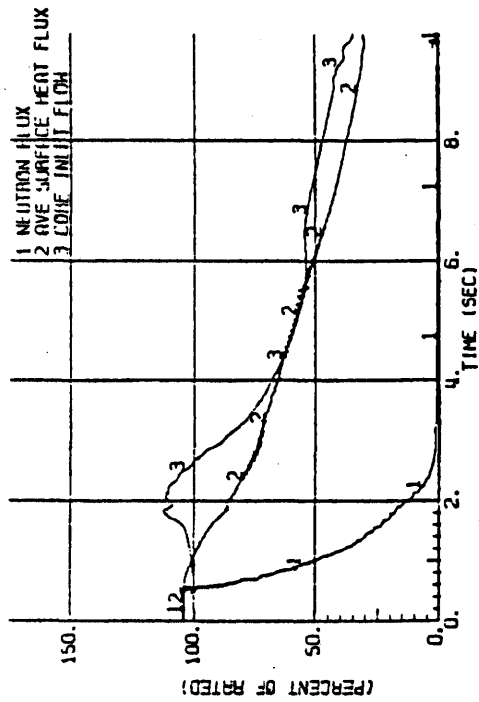
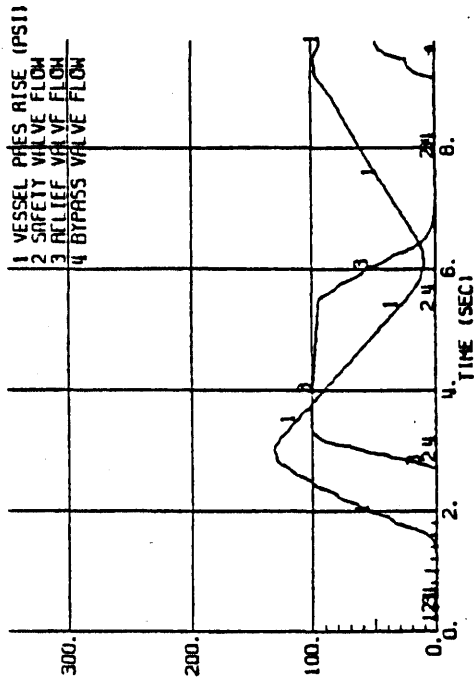

(Rev. 12 1/03)



PERRY NUCLEAR POWER PLANT

Three Second Closure of all Main
Steam Line Isolation Valves
With Position Switch Scram Trip

Figure 15.2-6a

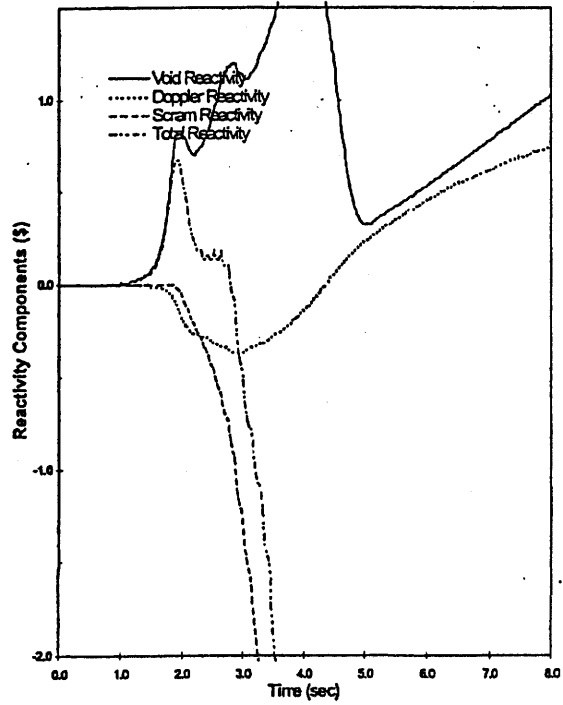
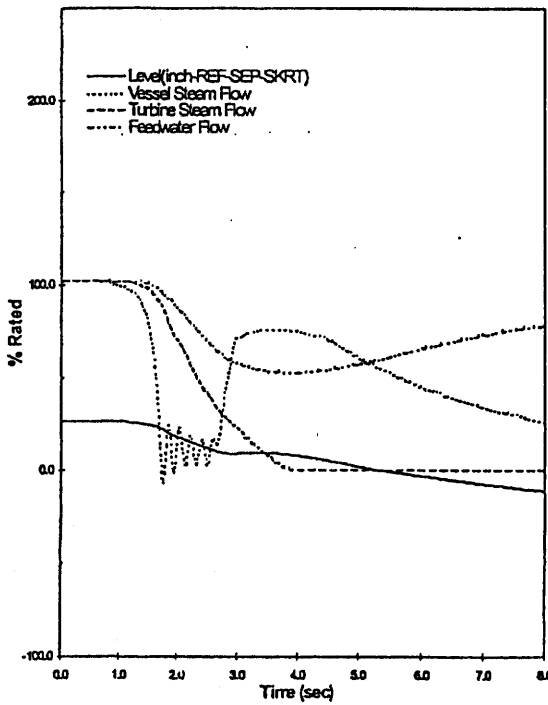
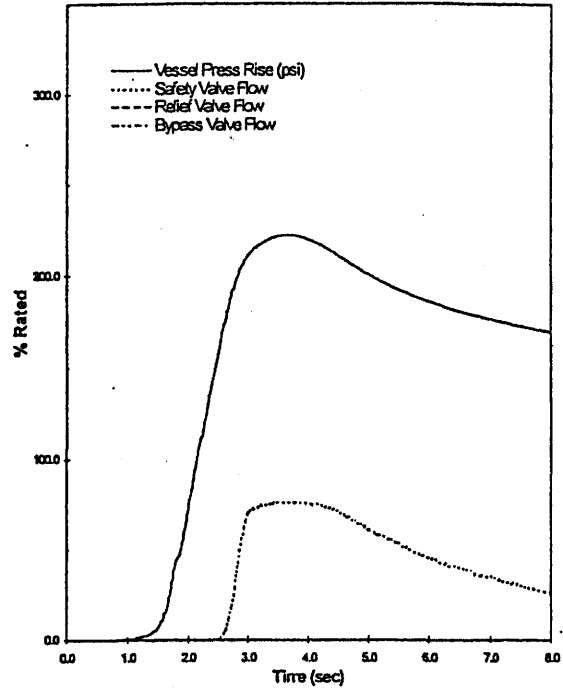
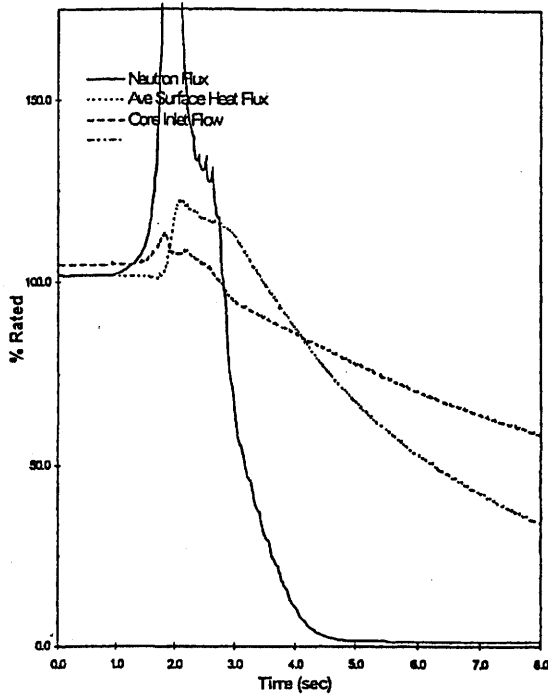

(Rev. 12 1/03)



PERRY NUCLEAR POWER PLANT

Response to MSIV
Closure With Flux Scram

Figure 15.2-6b

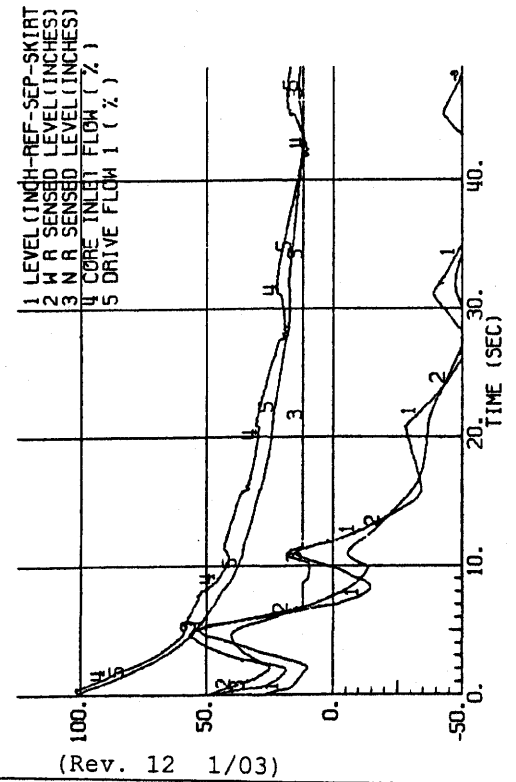
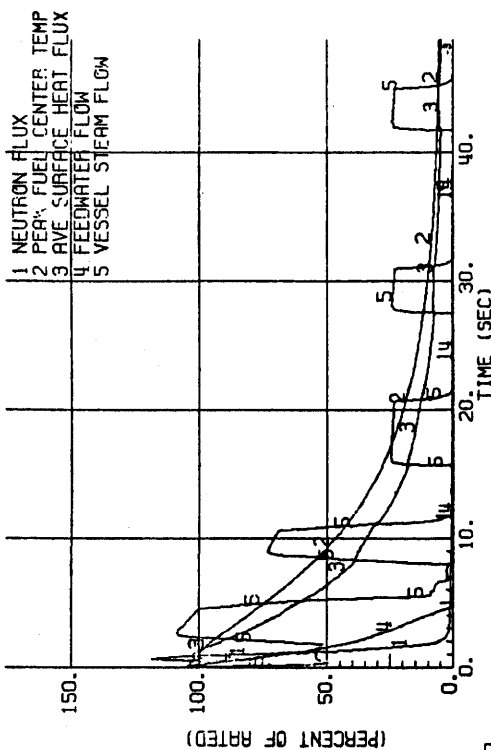
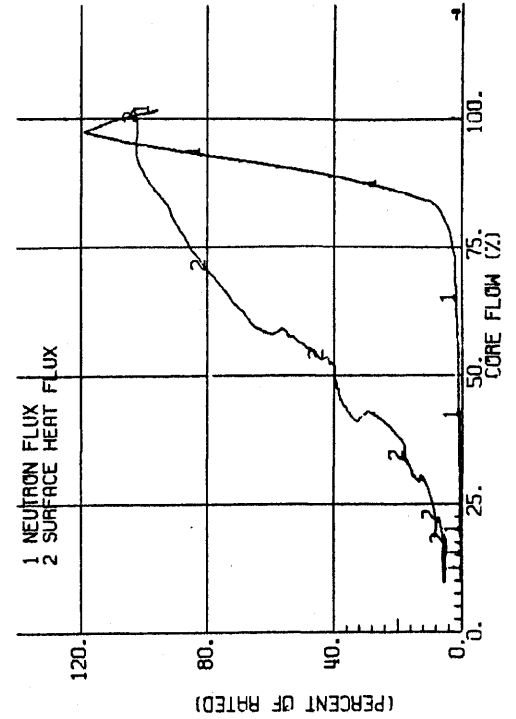
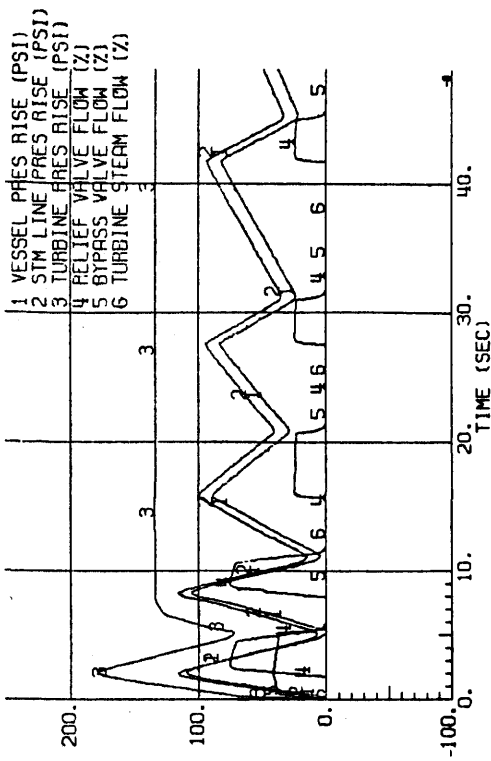

PERRY NUCLEAR POWER PLANT

Loss of Condenser Vacuum at 2
Inches Per Second

Figure 15.2-7

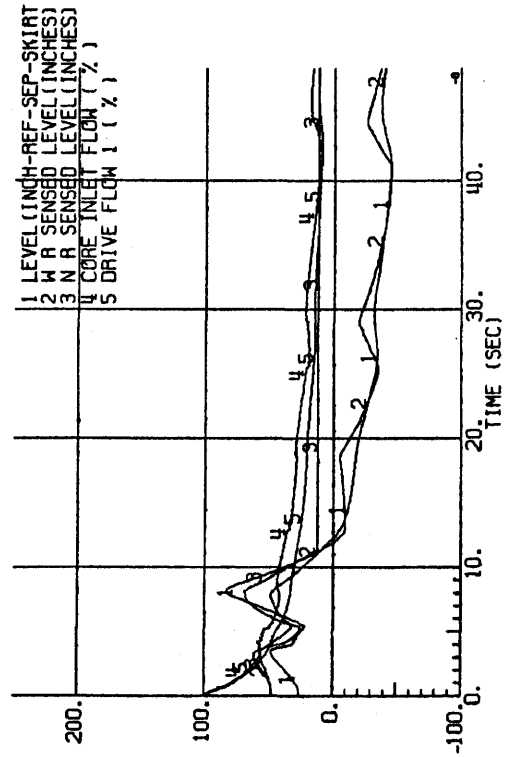
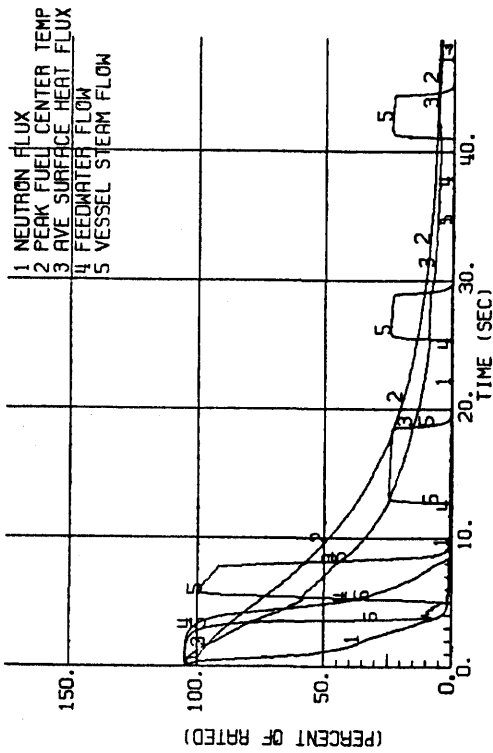
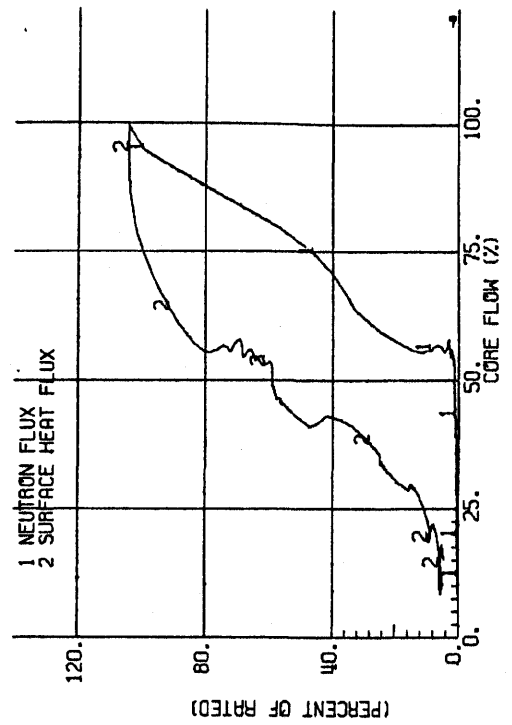
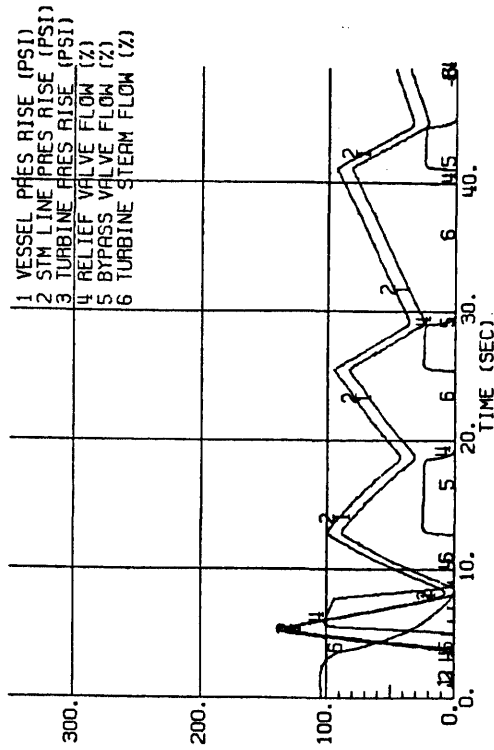

(Rev. 12 1/03)



PERRY NUCLEAR POWER PLANT

Loss of Auxiliary Power Transformer

Figure 15.2-8

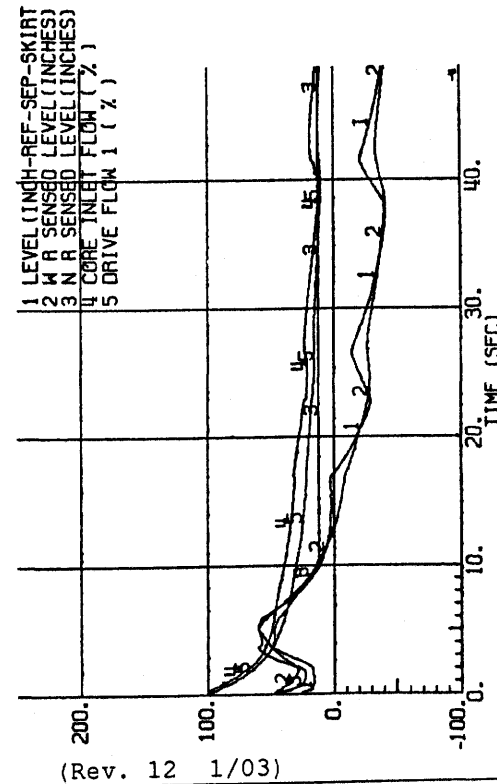
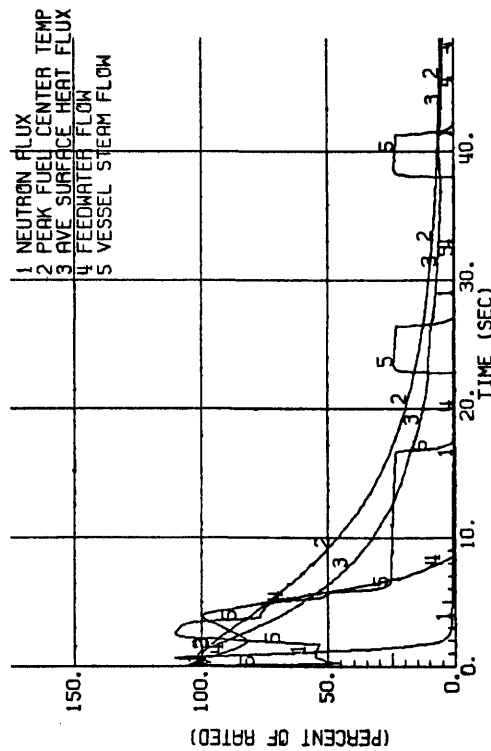
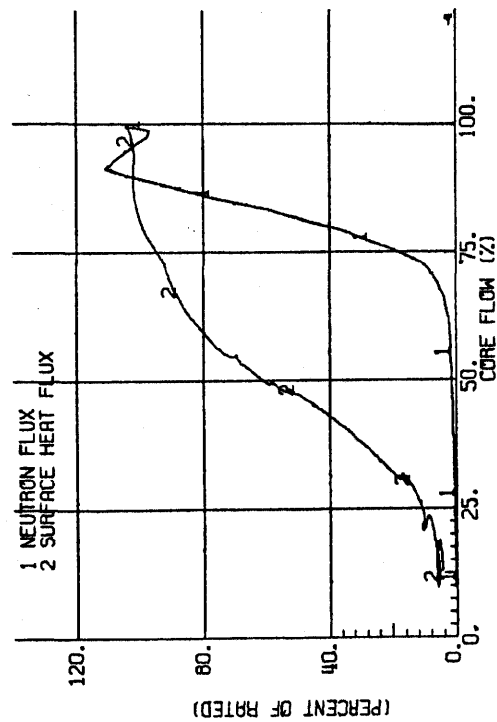
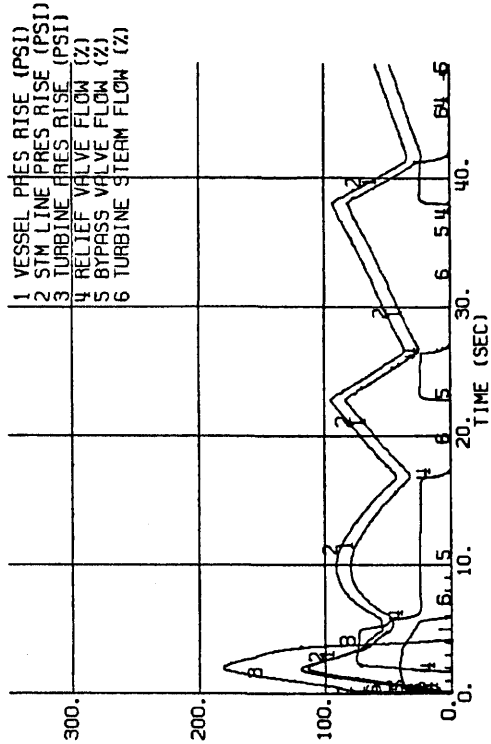

(Rev. 12 1/03)

PERRY NUCLEAR POWER PLANT

Loss of All Grid Connections

Figure 15.2-9

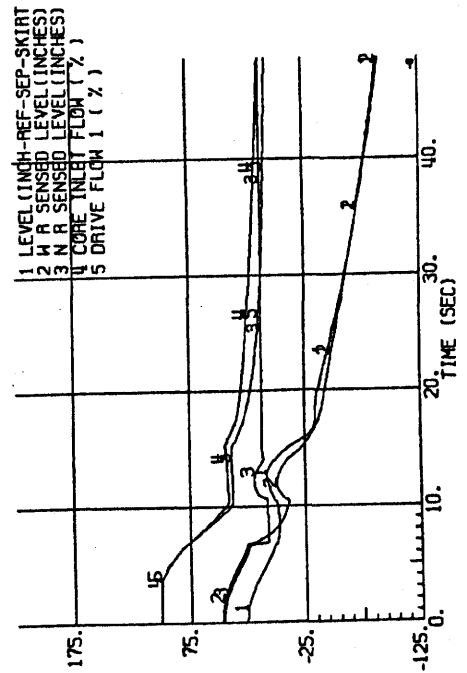
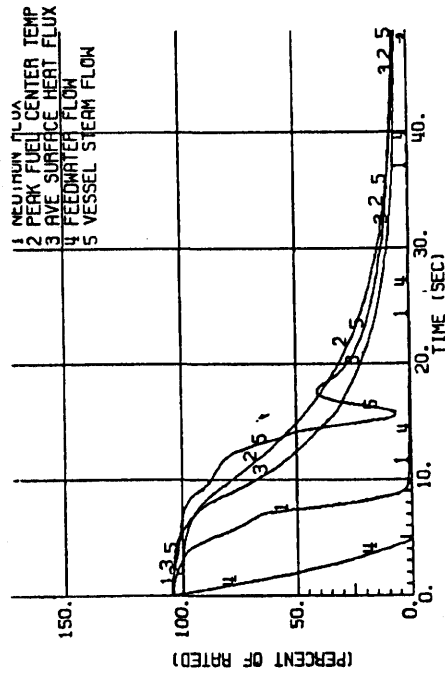
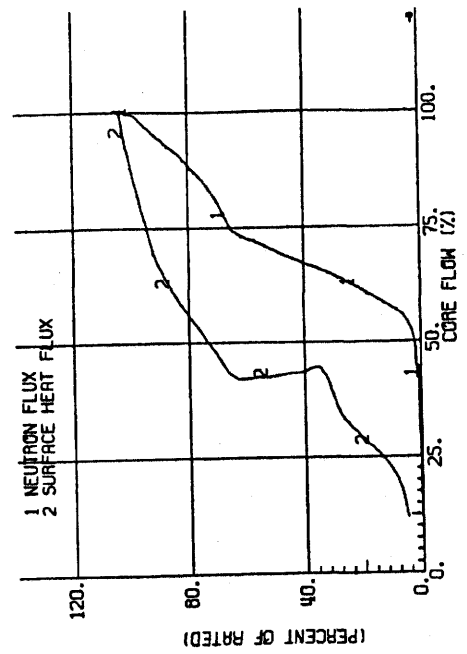
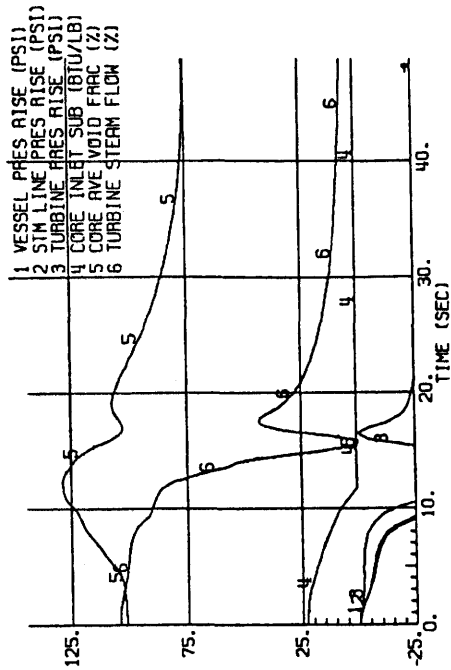

(Rev. 12 1/03)

PERRY NUCLEAR POWER PLANT

Loss of All Feedwater Flow

Figure 15.2-10

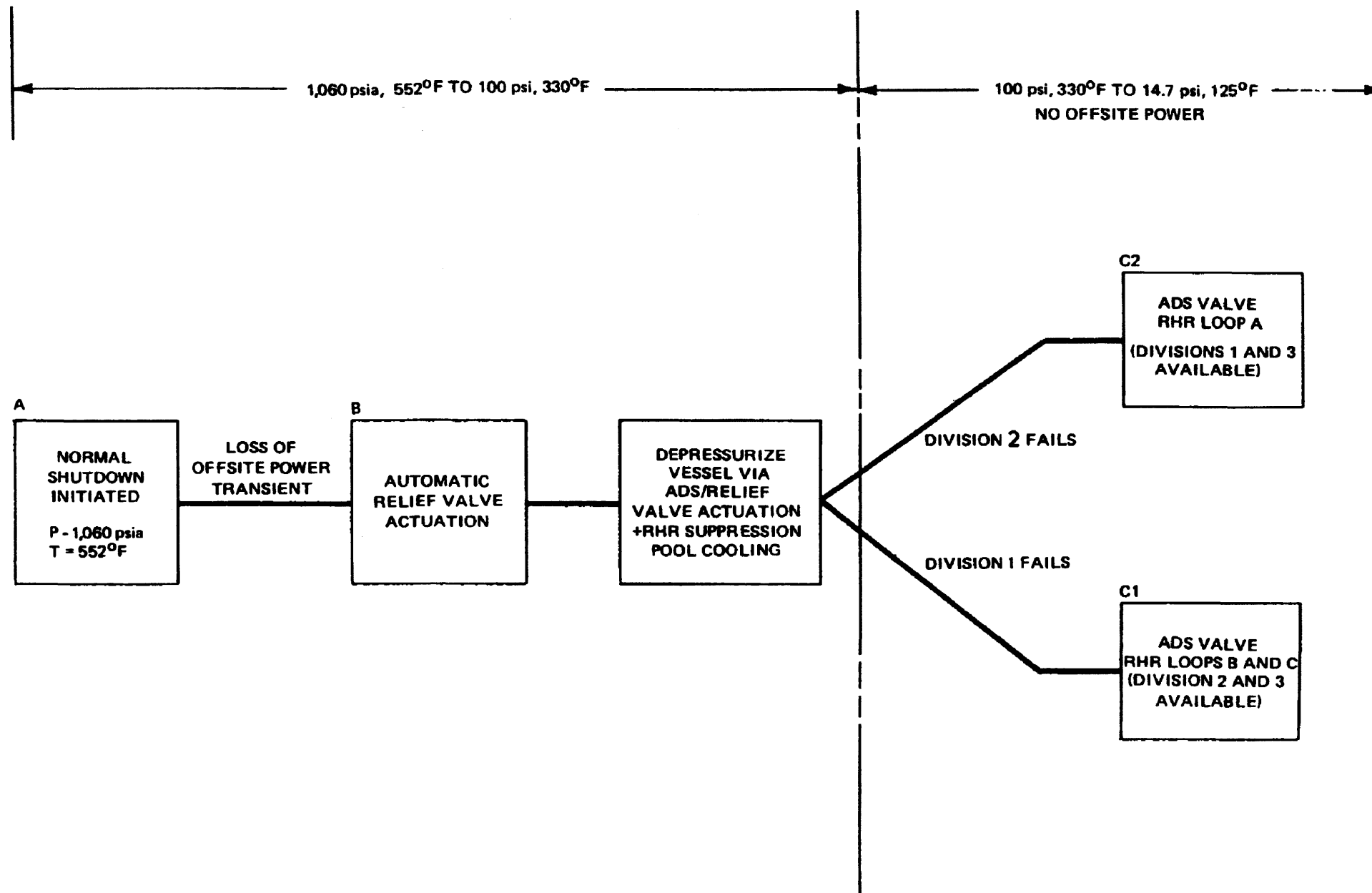

ACTIVITY A

Initial pressure 1,060 psia
Initial temperature 552°F

For purposes of this analysis, the following worst-case conditions are assumed to exist:

- a. The reactor is assumed to be operating at 102% rated power;
- b. A loss of power transient occurs (see Section 15.2.6);
- c. A simultaneous loss of onsite power (Division 1 or Division 2), which eventually results in the operator not being able to open one of the RHR shutdown cooling line suction valves.

ACTIVITY B

Initial system pressure 1,060 psia
Initial system temperature 552°F

Operator Actions

During approximately the first 13 minutes, reactor decay heat is passed to the suppression pool by automatic operation of the SRVs. Reactor water level will be returned to normal by HPCS and RCIC system automatic operation.

At approximately 13 minutes into the transient, the operator initiates depressurization of the reactor vessel. Controlled depressurization consists of controlling vessel pressure and water level by using selected safety/relief valves with the RCIC and HPCS systems. After approximately 13 minutes, it is assumed one RHR heat exchanger will be placed in the suppression pool cooling mode to remove decay heat. At this time, the suppression pool will be 107°F.

When the reactor pressure approaches 100 psig, the operator would normally prepare for operation of the RHR system in the shutdown cooling mode. At this time (135 min), the suppression pool temperature will be 146°F.

ACTIVITY C1 (Division 1 fails, Division 2 available)

System pressure approximately 100 psig
System temperature approximately 330°F

Operator Actions

The operator establishes a closed cooling path as follows:

- a. Utilizing RHR loops B and C together, water is taken from the suppression pool and is pumped directly into the reactor vessel. The water passes through the vessel (picking up decay heat) and out the ADS valves returning to the suppression pool as shown in Figure 15.2-14. Suppression pool water is then cooled by operation of RHR loop B in the cooling mode (see Figure 15.2-15). In this alternate cooling path, RHR loop C is used for injection and RHR loop B for cooling. Cold shutdown is achieved approximately 9.5 hours after transient occurred.

ACTIVITY C2 (Division 2 fails, Division 1 available)

System pressure approximately 100 psig
System temperature approximately 230°F

Operator Actions

Utilizing RHR loop A (Figure 15.2-15, Sheet 2 of 2) instead of loop B, an alternate cooling path is established as in Activity C1. Item (a) above. LPCS is utilized in lieu of LPCI C. Again, cold shutdown is reached in approximately 9.5 hours.

(REV. 19 10/2015)

PERRY NUCLEAR POWER PLANT 10 CENTER RD., PERRY, OHIO 44081	
ADS/RHR COOLING LOOPS	
FIGURE 15.2-11	

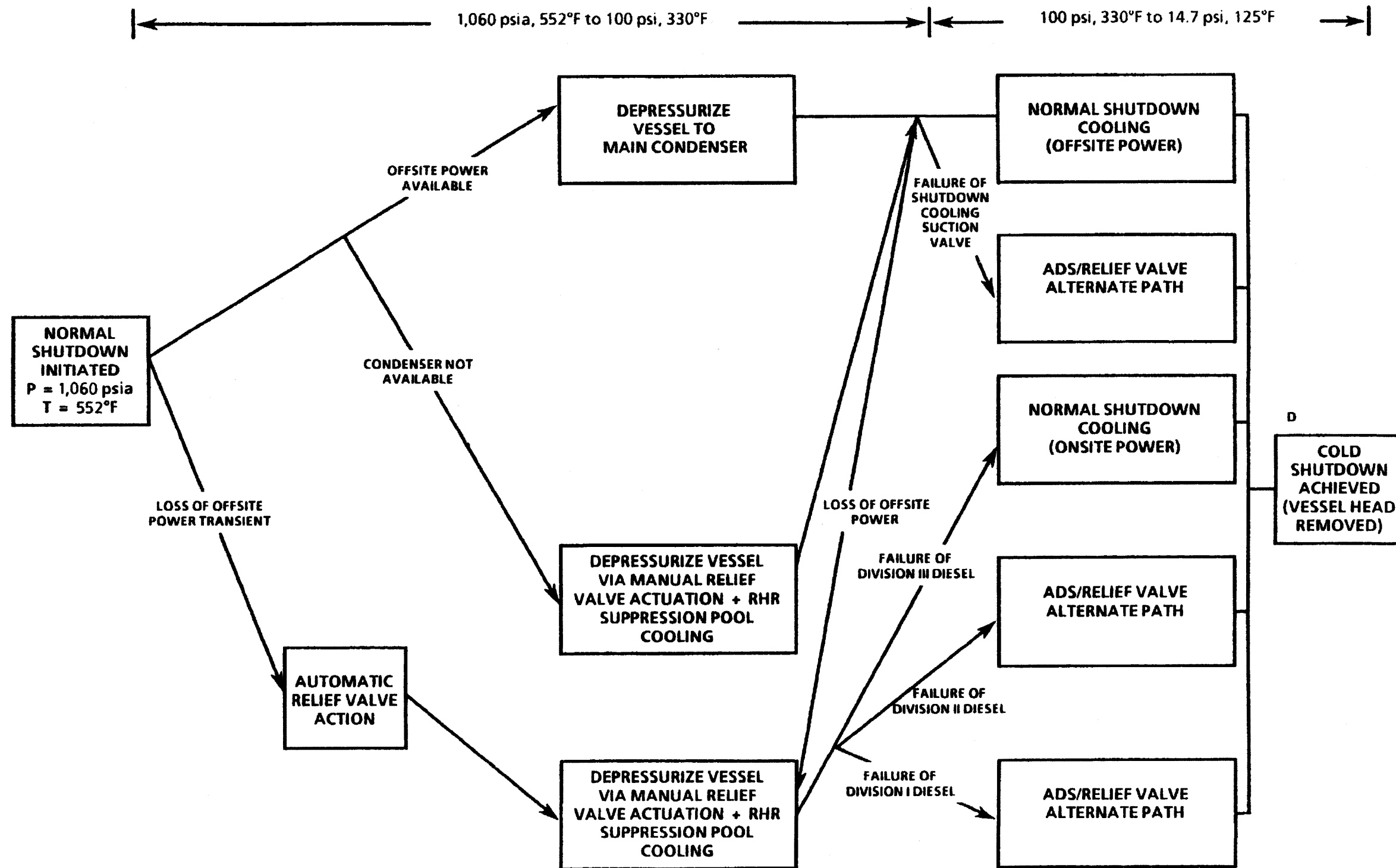

(REV. 19 10/2015)

PERRY NUCLEAR POWER PLANT
10 CENTER RD., PERRY, OHIO 44081

SUMMARY OF PATHS AVAILABLE
TO ACHIEVE COLD SHUTDOWN

FIGURE 15.2-12

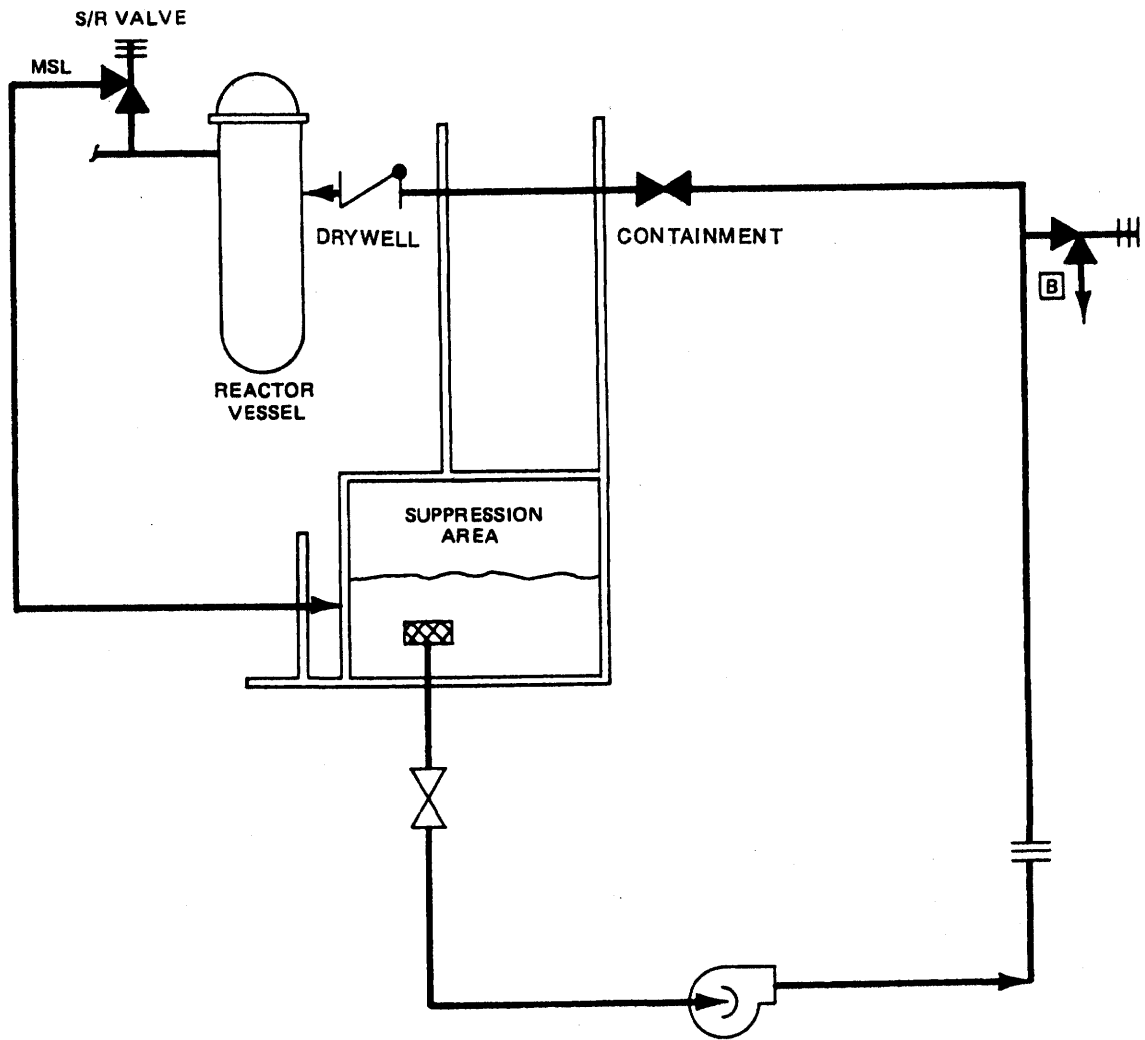

(Rev. 12 1/03)



PERRY NUCLEAR POWER PLANT

RHR Loop C

Figure 15.2-14 (Sheet 1 of 2)

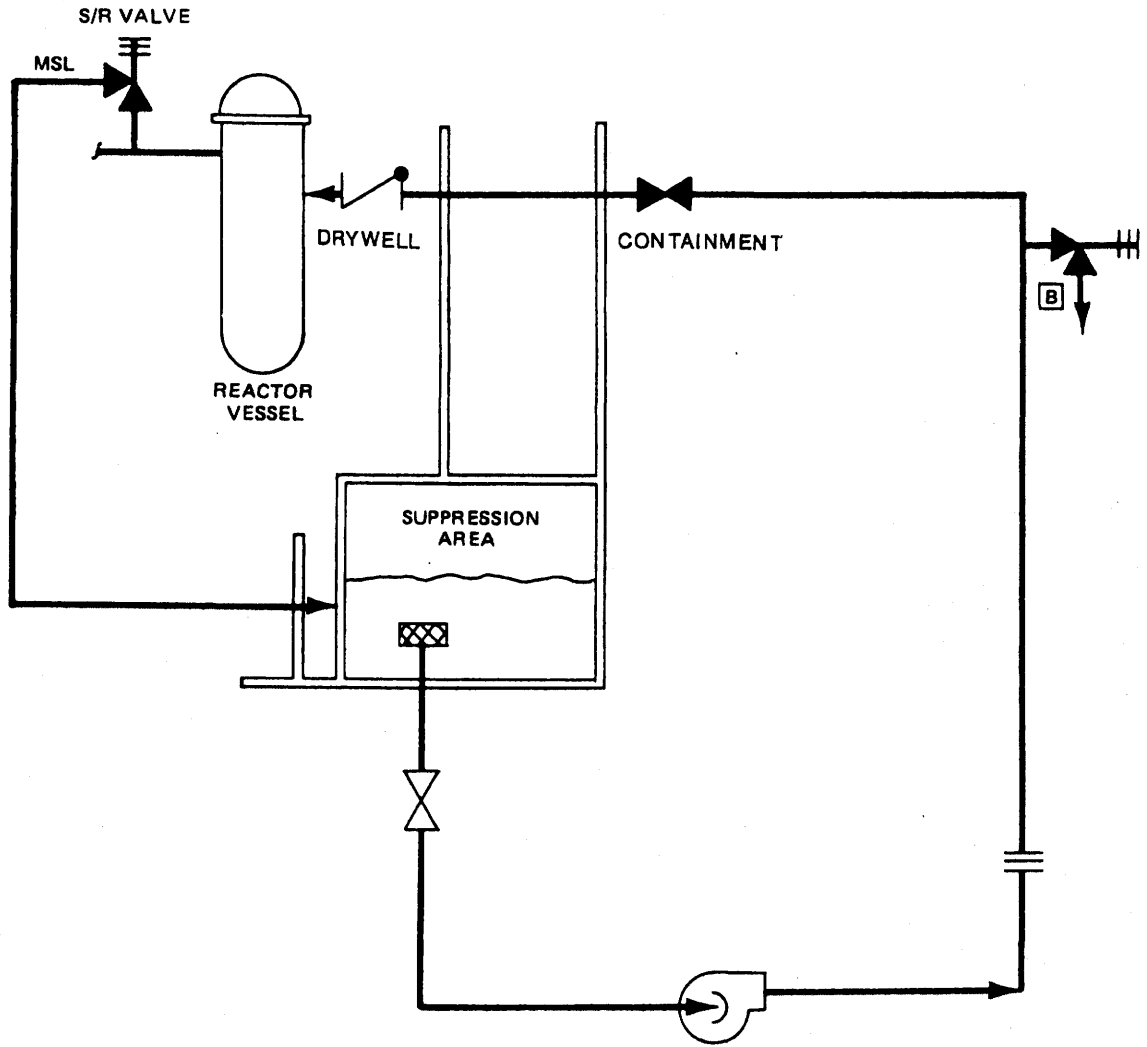

(Rev. 12 1/03)



PERRY NUCLEAR POWER PLANT

LPCS

Figure 15.2-14 (Sheet 2 of 2)

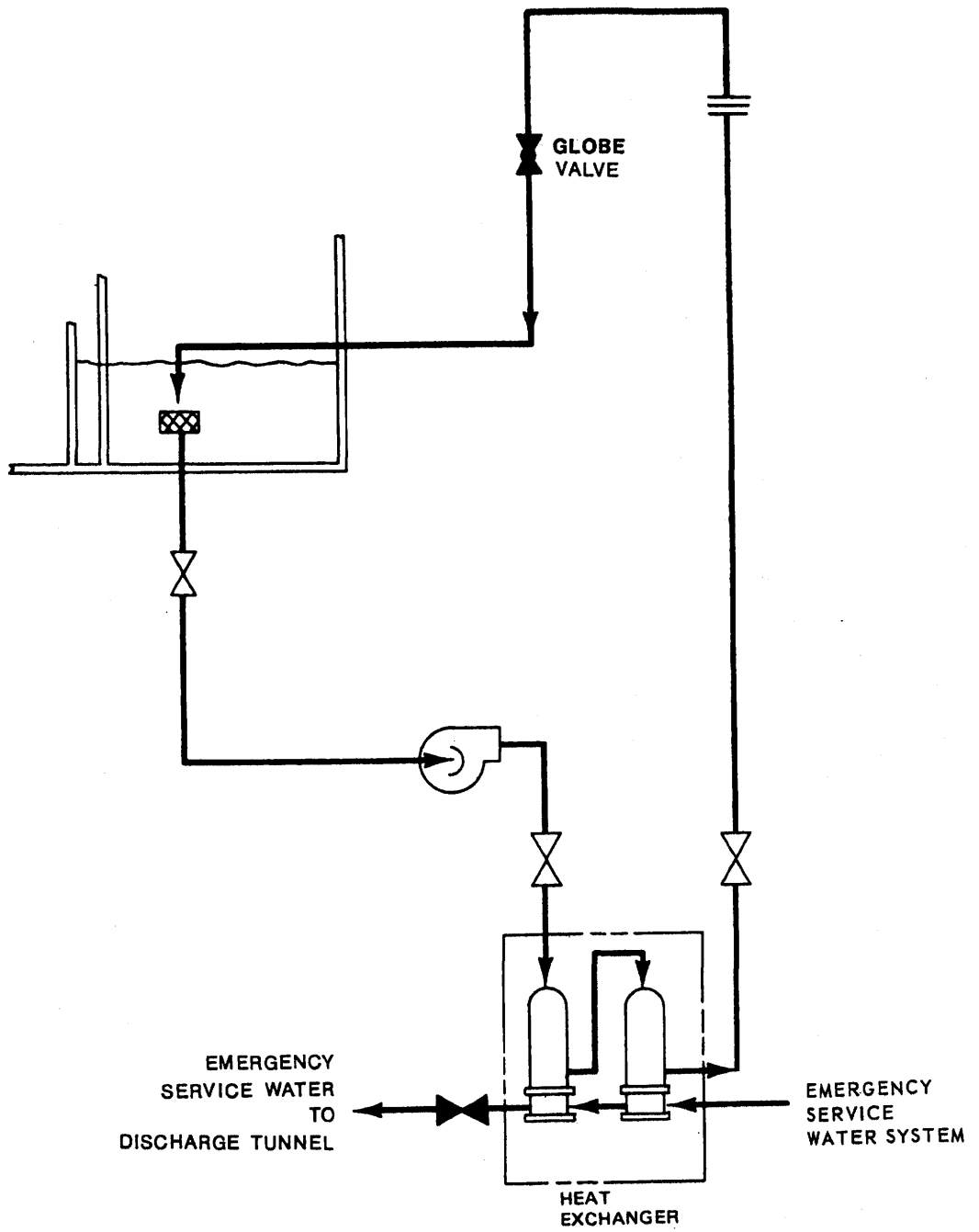

(Rev. 12 1/03)



PERRY NUCLEAR POWER PLANT

RHR Loop B (Suppression Pool Cooling Mode)

Figure 15.2-15 (Sheet 1 of 2)

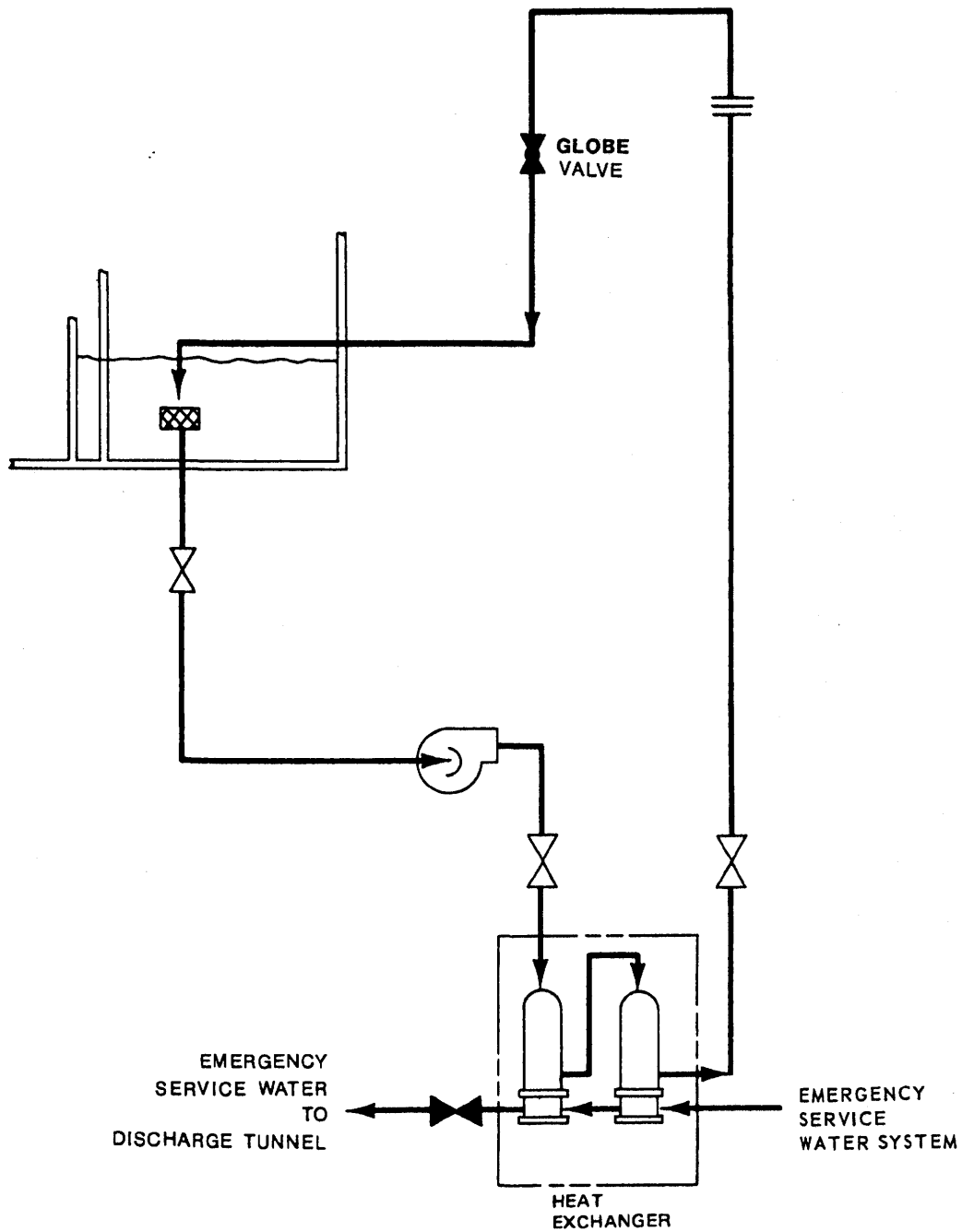

(Rev. 12 1/03)



PERRY NUCLEAR POWER PLANT

RHR Loop A (Suppression Pool
Cooling Mode)

Figure 15.2-15 (Sheet 2 of 2)

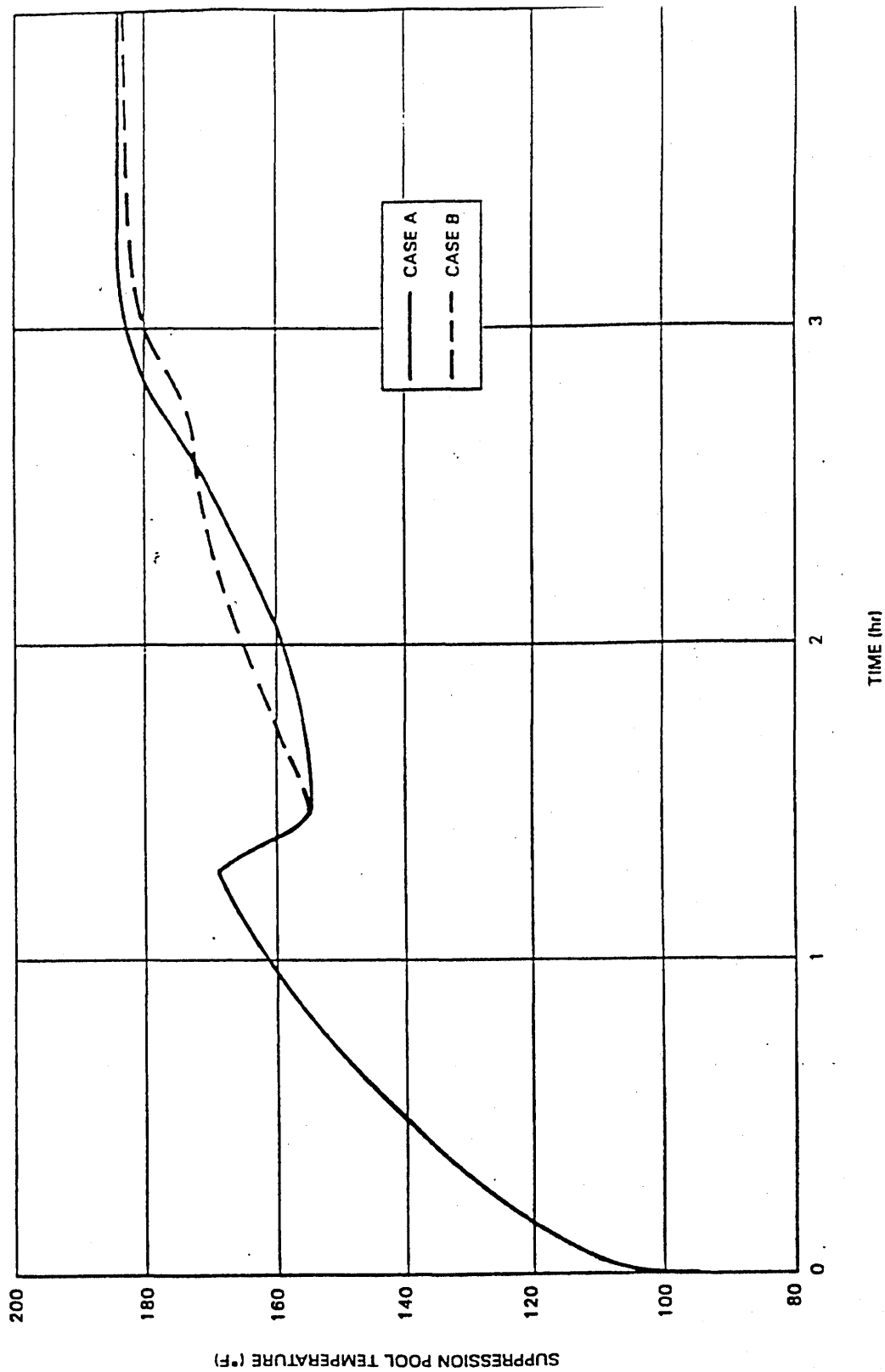

SUPPRESSION POOL TEMPERATURE (°F)

(Rev. 12 1/03)



PERRY NUCLEAR POWER PLANT

Suppression Pool Temperature
During Alternate Shutdown
(at 3729 MWt)

Figure 15.2-17

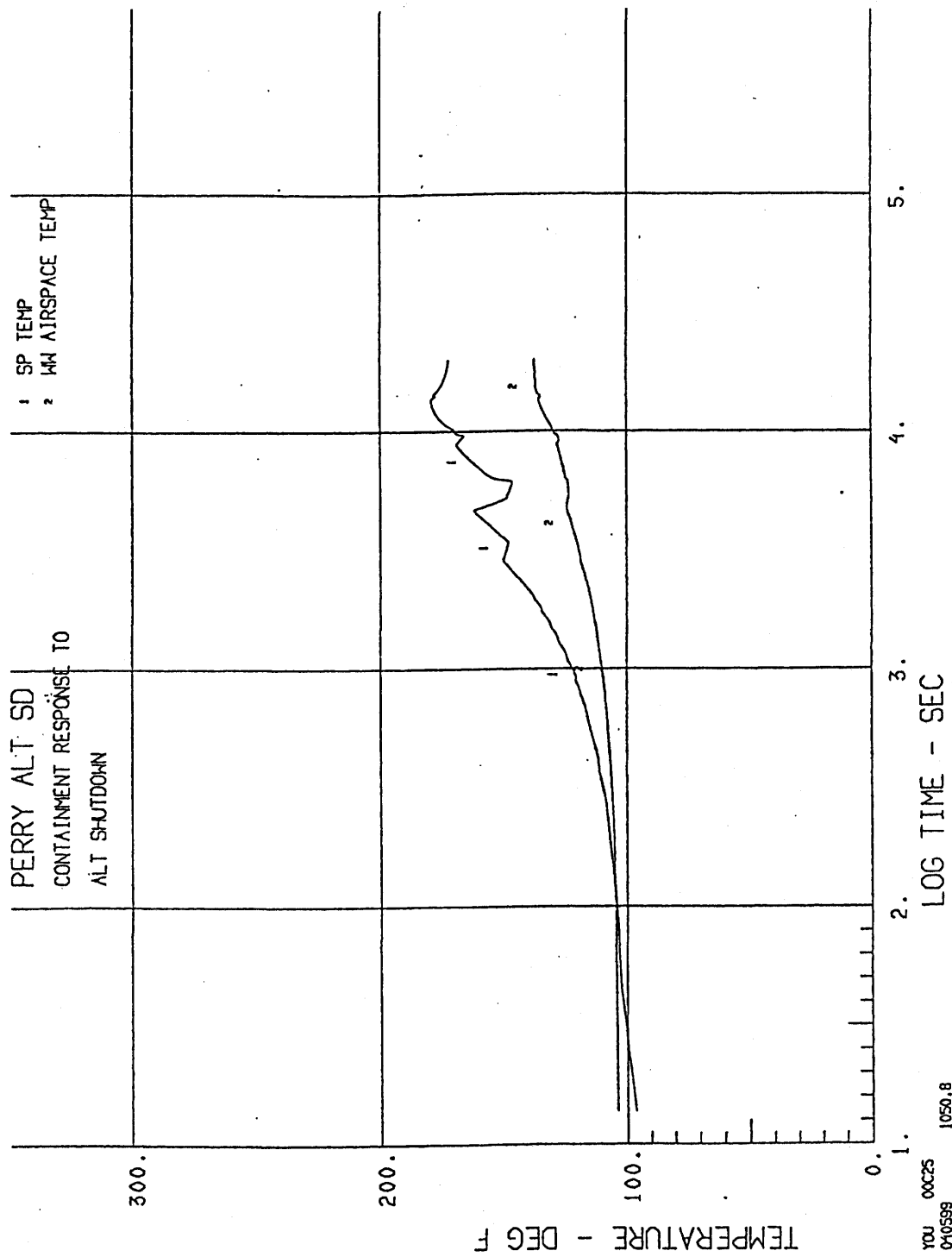

(Rev. 12 1/03)



PERRY NUCLEAR POWER PLANT

Suppression Pool Temperature
 During Alternate Shutdown
 (at 3833 MWt)

Figure 15.2-17a

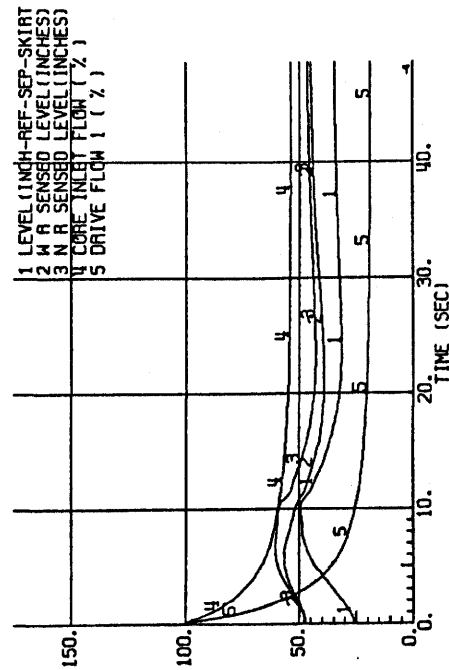
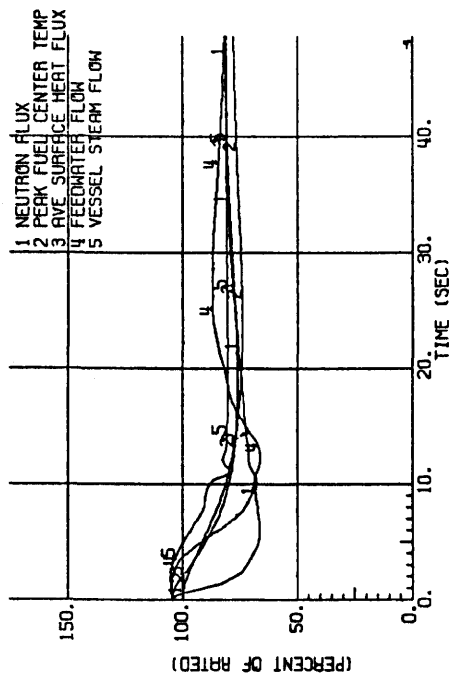
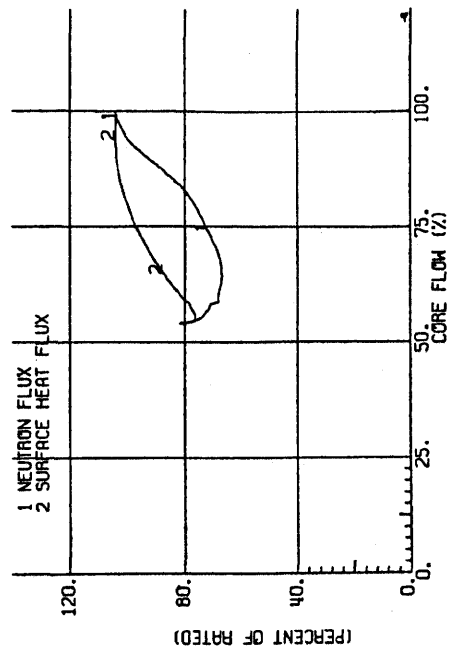
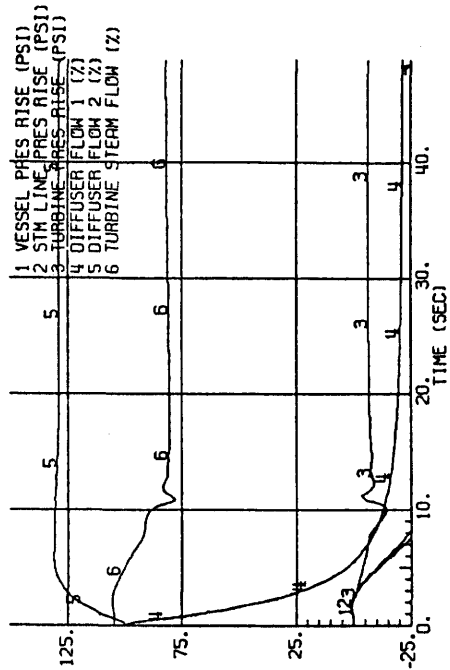

(Rev. 12 1/03)



PERRY NUCLEAR POWER PLANT

Trip of One Recirculation
Pump Motor

Figure 15.3-1

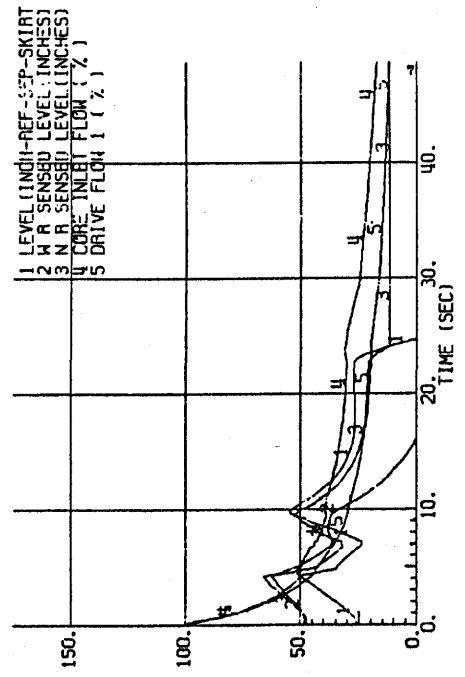
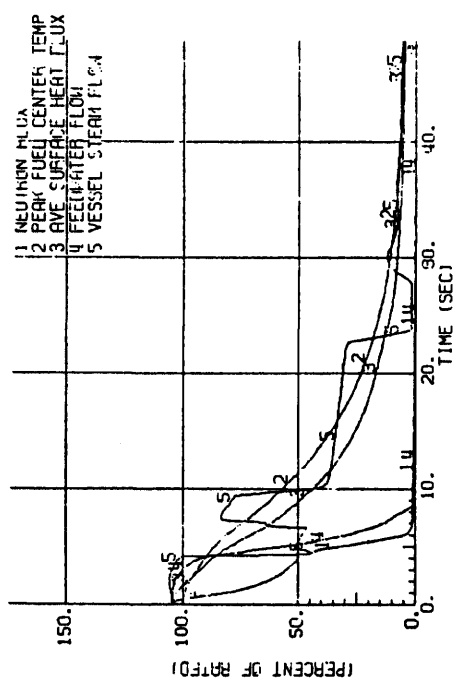
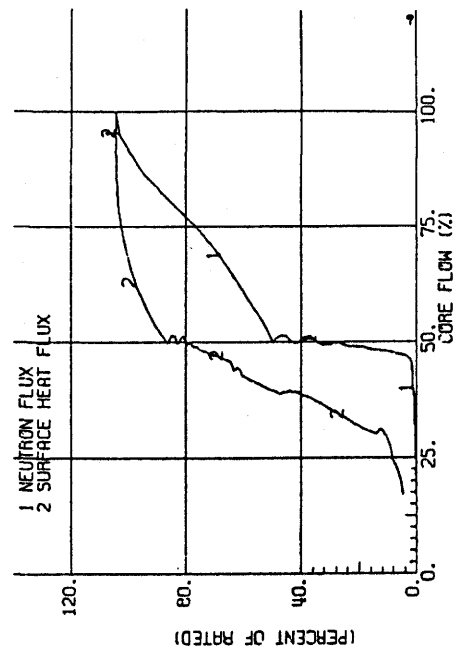
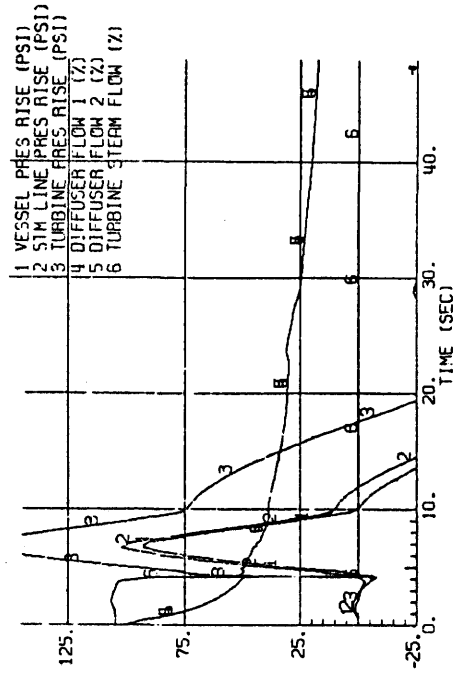

(Rev. 12 1/03)

PERRY NUCLEAR POWER PLANT

Trip of Both Recirculation
 Pump Motors

Figure 15.3-2

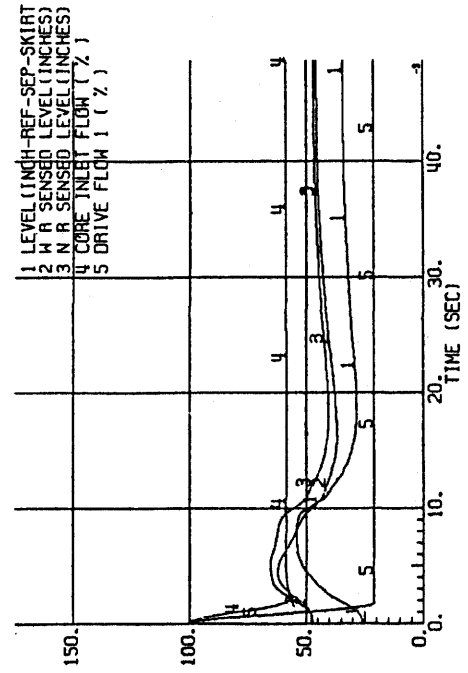
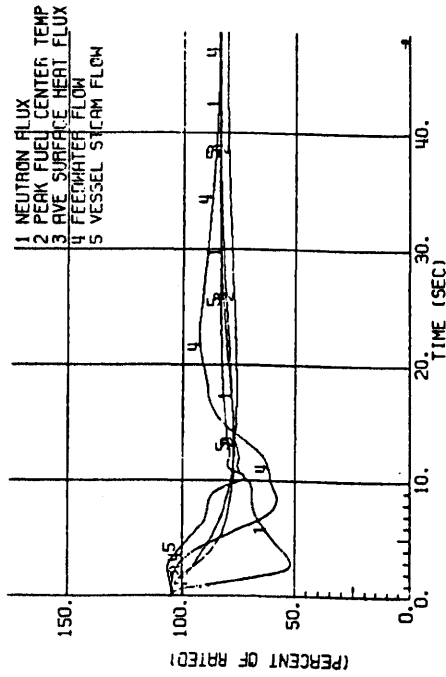
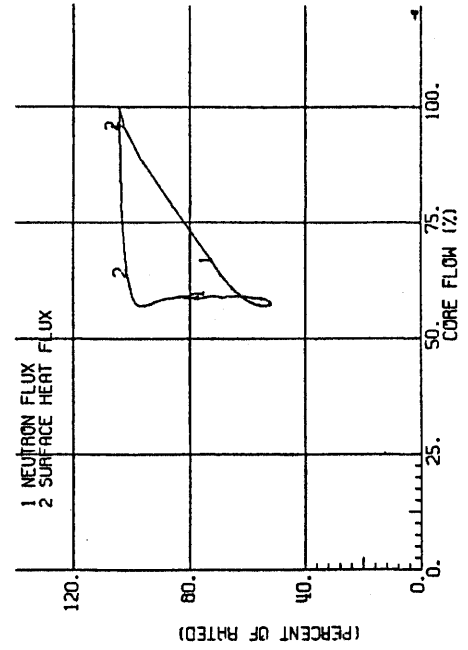
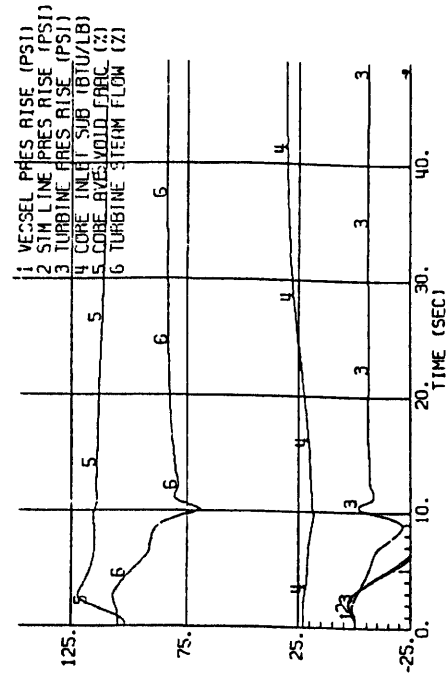

(Rev. 12 1/03)



PERRY NUCLEAR POWER PLANT

Fast Closure of One Main
 Recirculation Valve at
 60% Per Second

Figure 15.3-3

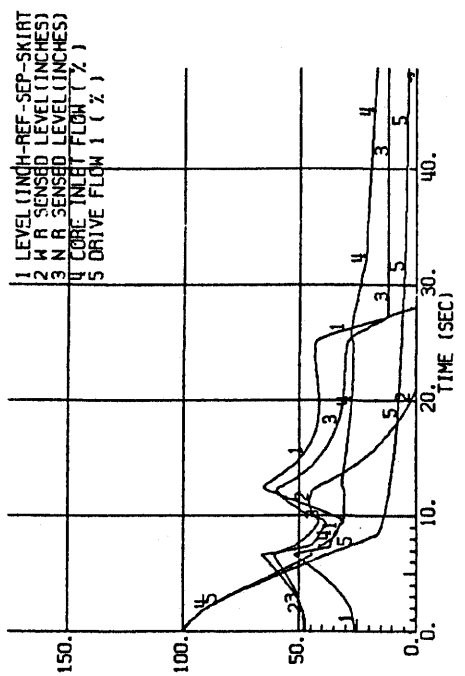
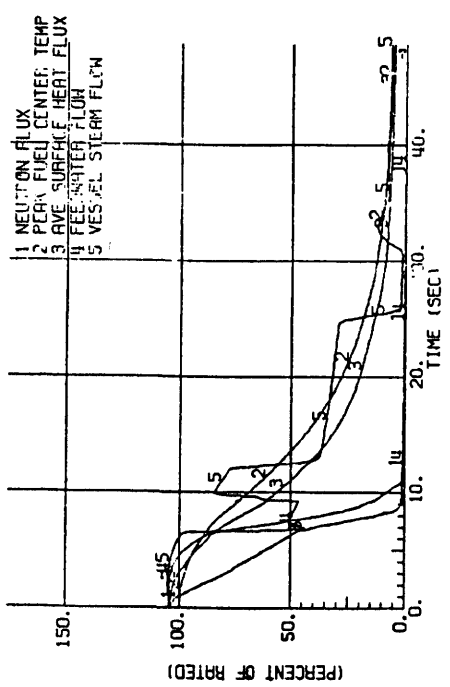
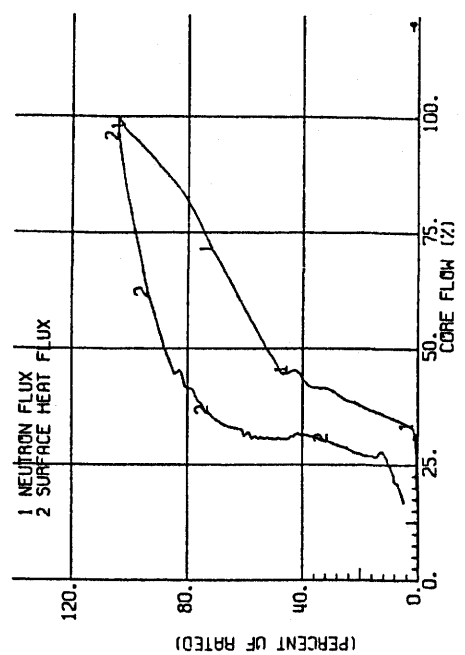
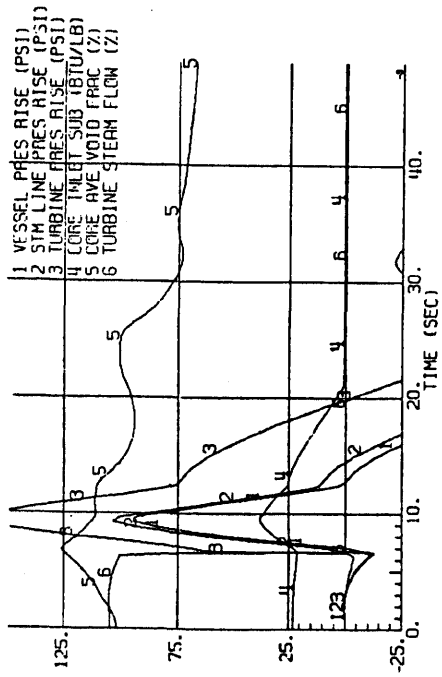

(Rev. 12 1/03)



PERRY NUCLEAR POWER PLANT

Fast Closure of Both Main
 Recirculation Valves at
 11% Per Second

Figure 15.3-4

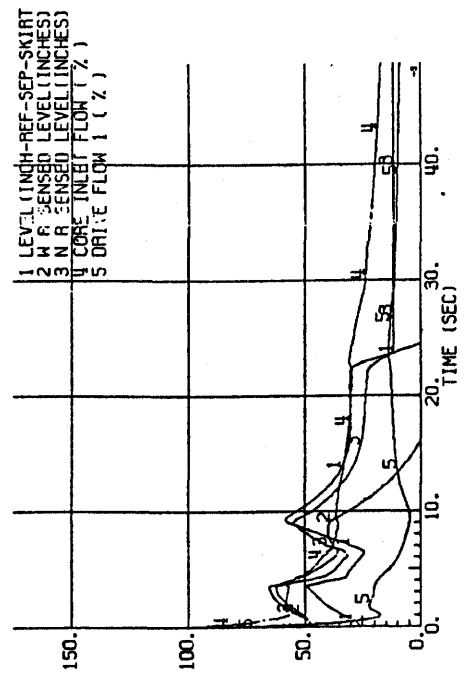
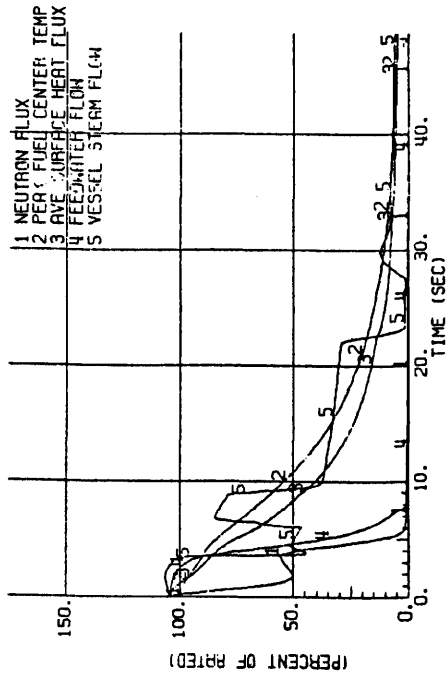
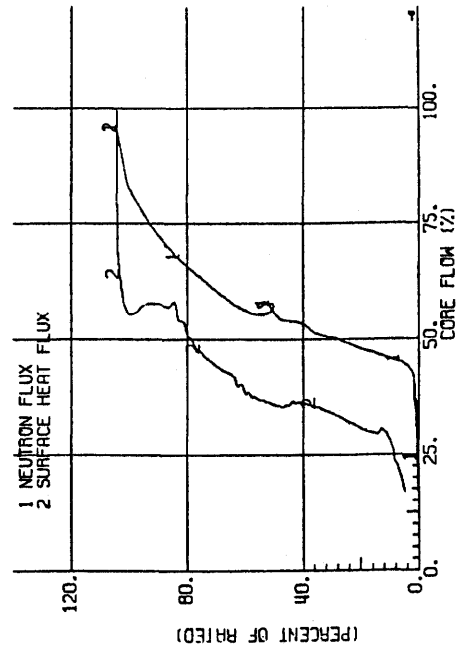
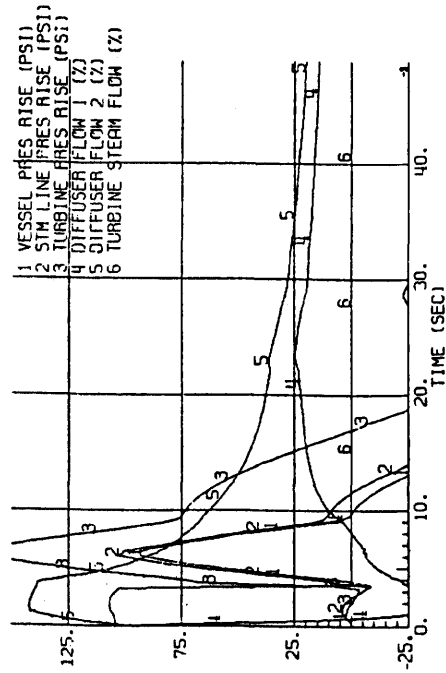

(Rev. 12 1/03)



PERRY NUCLEAR POWER PLANT

Seizure of One Recirculation Pump

Figure 15.3-5

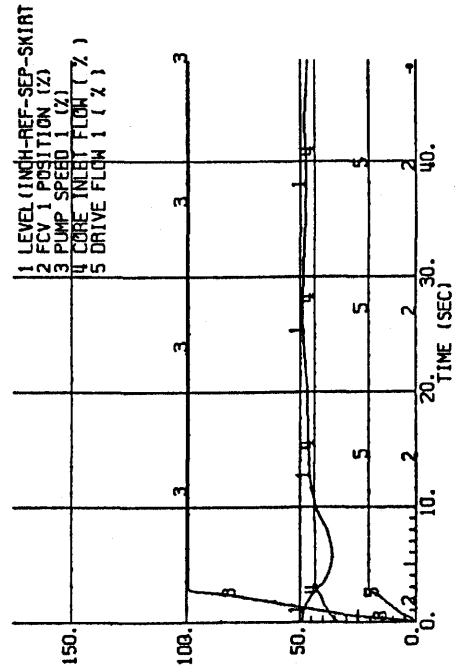
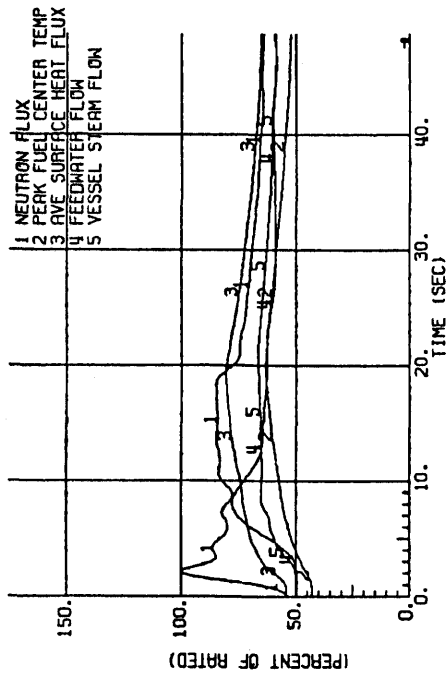
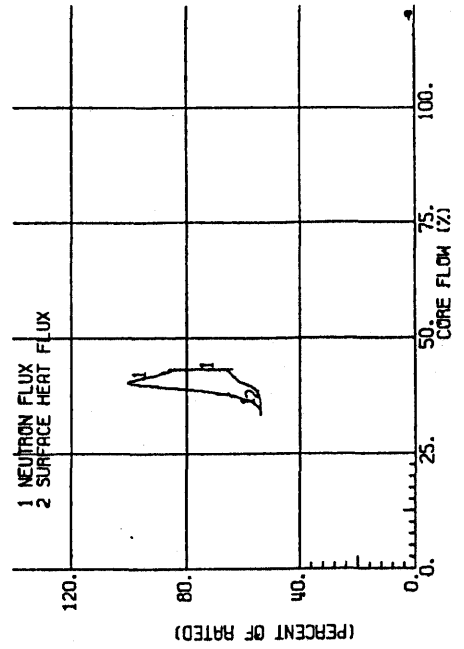
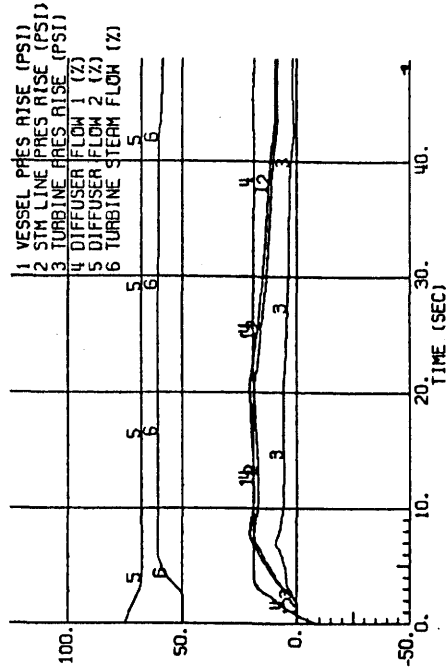

(Rev. 12 1/03)

PERRY NUCLEAR POWER PLANT

Abnormal Startup of Idle
 Recirculation Loop Pump

Figure 15.4-1

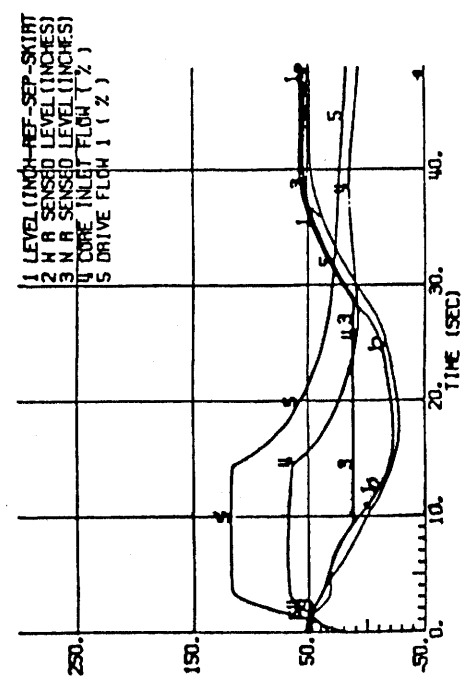
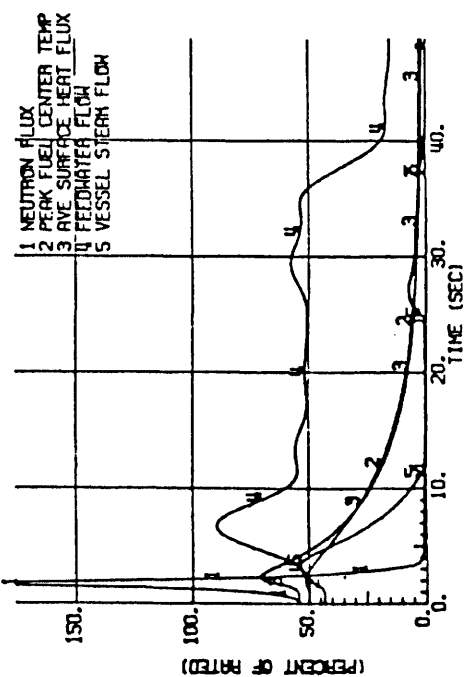
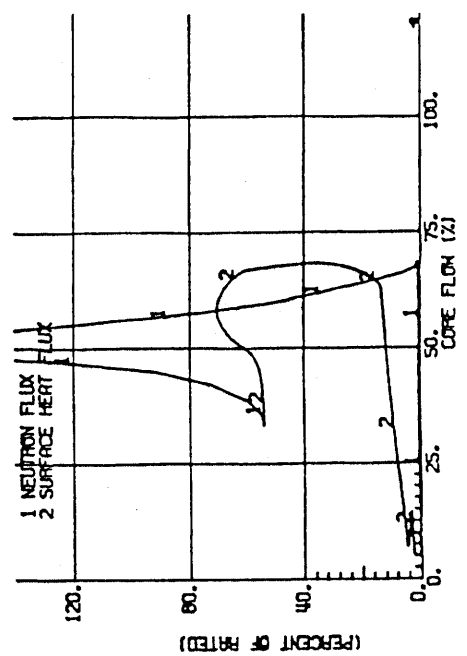
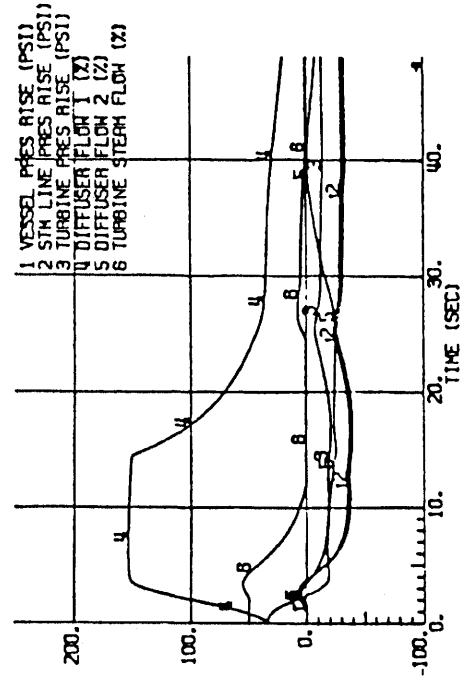

(Rev. 12 1/03)



PERRY NUCLEAR POWER PLANT

Fast Opening of One Main
Recirculation Loop Valve at
30% Per Second

Figure 15.4-2

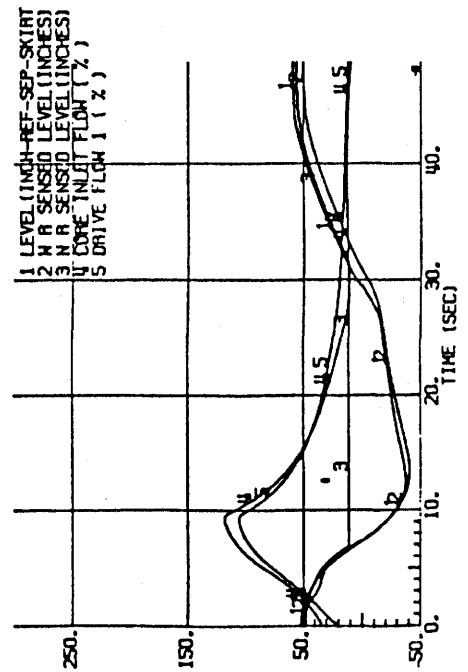
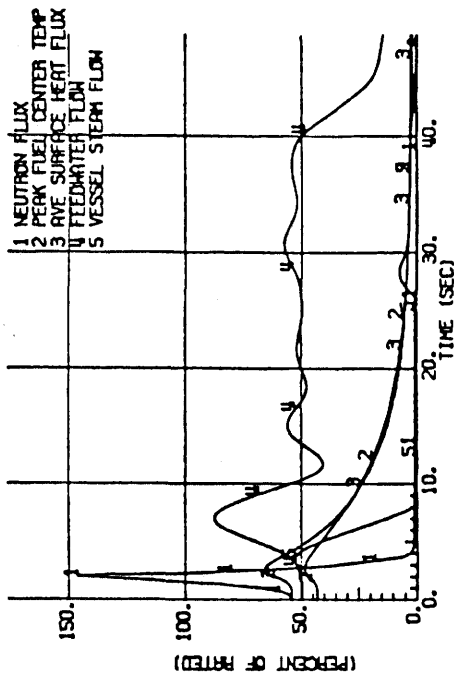
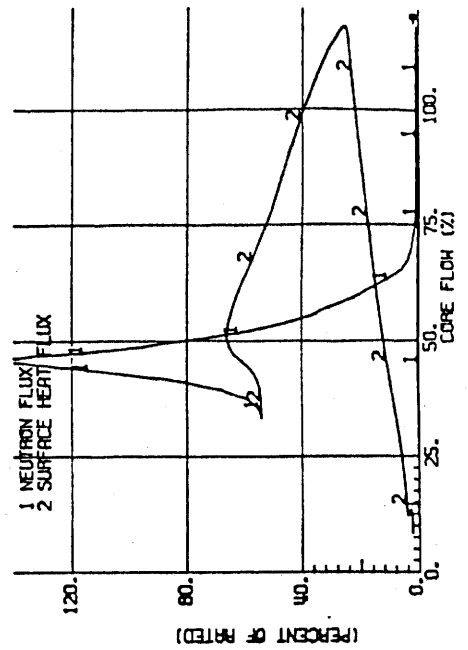
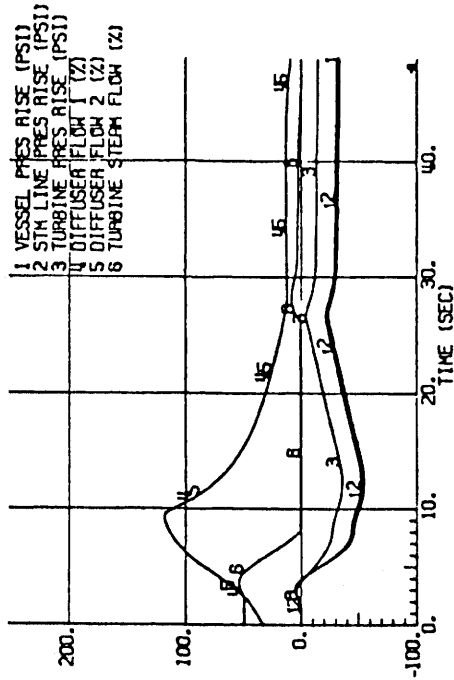

(Rev. 12 1/03)

PERRY NUCLEAR POWER PLANT

Fast Opening of Both Main
 Recirculation Loop Valves at
 11% Per Second

Figure 15.4-3

CONTROL ROD CONFIGURATION
IN NOTCHES WITHDRAWN

AXIAL AVERAGE EXPOSURES
TARGET
MWD/ST

AXIAL C U R R E N T
MWD/ST

AXIAL
POWER

K	AXIAL POWER	AXIAL C U R R E N T MWD/ST	AXIAL AVERAGE EXPOSURES TARGET MWD/ST	1	3	5	7	9	11	13	15	17	19	21	23	25	27	29	
25	0.1741	4480.6	5008.1																
24	0.3266	7092.0	7809.5	59															1
23	0.7259	15858.8	17394.8																3
22	0.8882	19776.8	21617.6																5
21	1.0141	22992.4	25092.5																7
20	1.0944	25209.3	27461.2																9
19	1.1346	26819.6	29119.5					40											11
18	1.1423	28005.1	30370.2																13
17	1.1012	28727.6	31132.9	47															15
16	1.1266	26580.4	28843.6																17
15	1.1038	26989.6	29371.4				40	14											19
14	1.1010	27490.9	30094.0																21
13	1.1017	27930.5	30753.6	39															23
12	1.1079	28299.4	31334.5																25
11	1.1208	28563.5	31824.8				14												27
10	1.1388	28773.1	32155.0																29
9	1.1640	28828.6	32252.1																
8	1.1904	29077.1	32591.1																
7	1.2152	29408.2	32982.3				14												
6	1.2366	29656.9	33252.8																
5	1.2458	29635.0	33195.8																
4	1.2206	28720.1	32225.5																
3	1.1549	25875.0	29301.1				40	14											
2	0.9177	19691.1	22552.2																
1	0.2528	6033.2	6949.1																

2 6 10 14 18 22 26 30 34 38 42 46 50 54 58

(Rev. 12 1/03)

PERRY NUCLEAR POWER PLANT

Critical Rod Pattern for
Misplaced Bundle Accident

Figure 15.4-4

1. SCENARIO 1 EVALUATION
CONDENSER

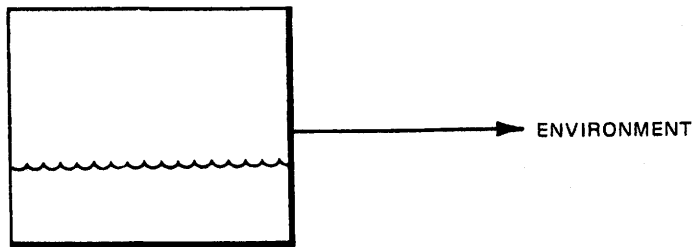

2. SCENARIO 2 EVALUATION
CONDENSER

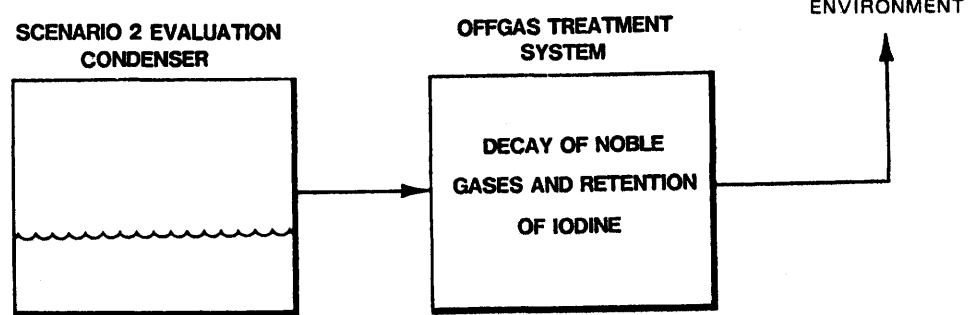

(Rev. 12 1/03)



PERRY NUCLEAR POWER PLANT

Leakage Path Model for Rod
Drop Accident

Figure 15.4-5

PLANT
COORDINATE

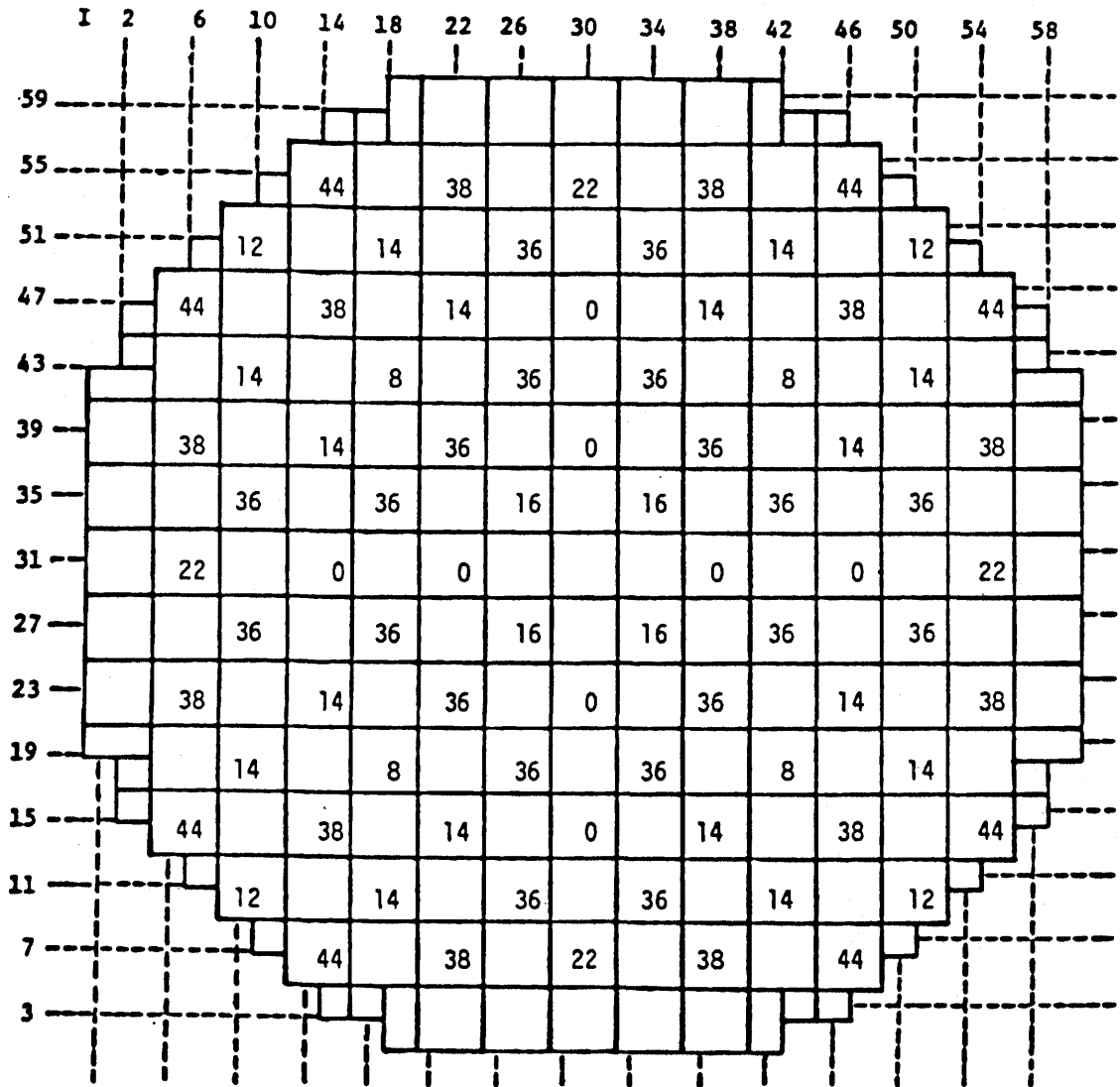

(Rev. 12 1/03)



PERRY NUCLEAR POWER PLANT

Rod Pattern for RWE Analysis $\frac{1}{4}$
Core Geometry (Rated Power Case)

Figure 15.4-6

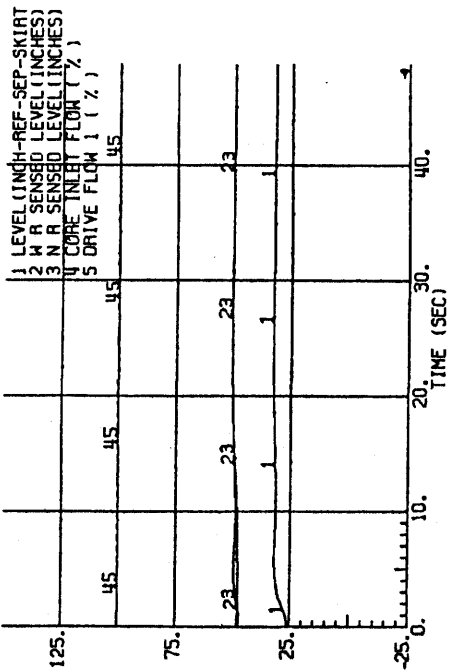
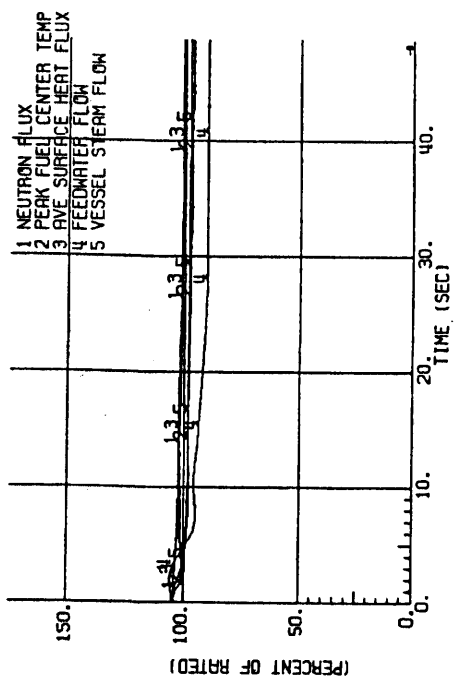
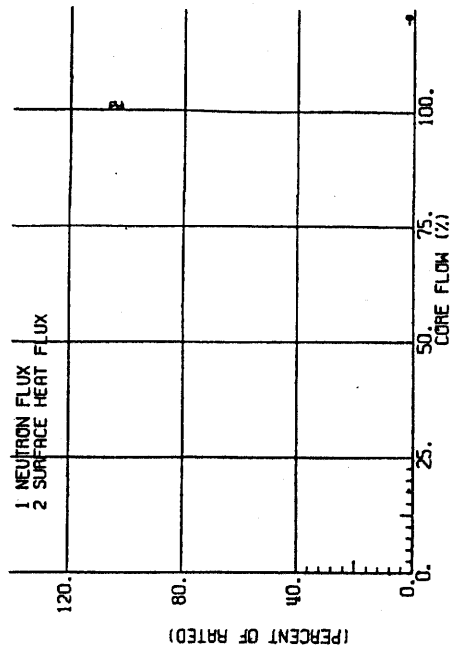
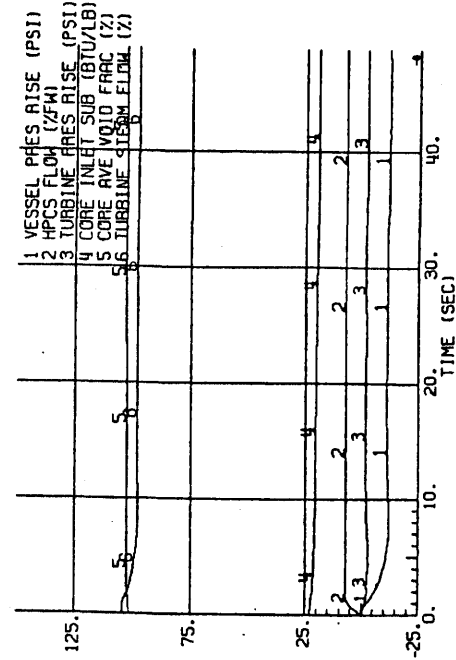

(Rev. 12 1/03)

PERRY NUCLEAR POWER PLANT

Inadvertent Startup of HPCS

Figure 15.5-1

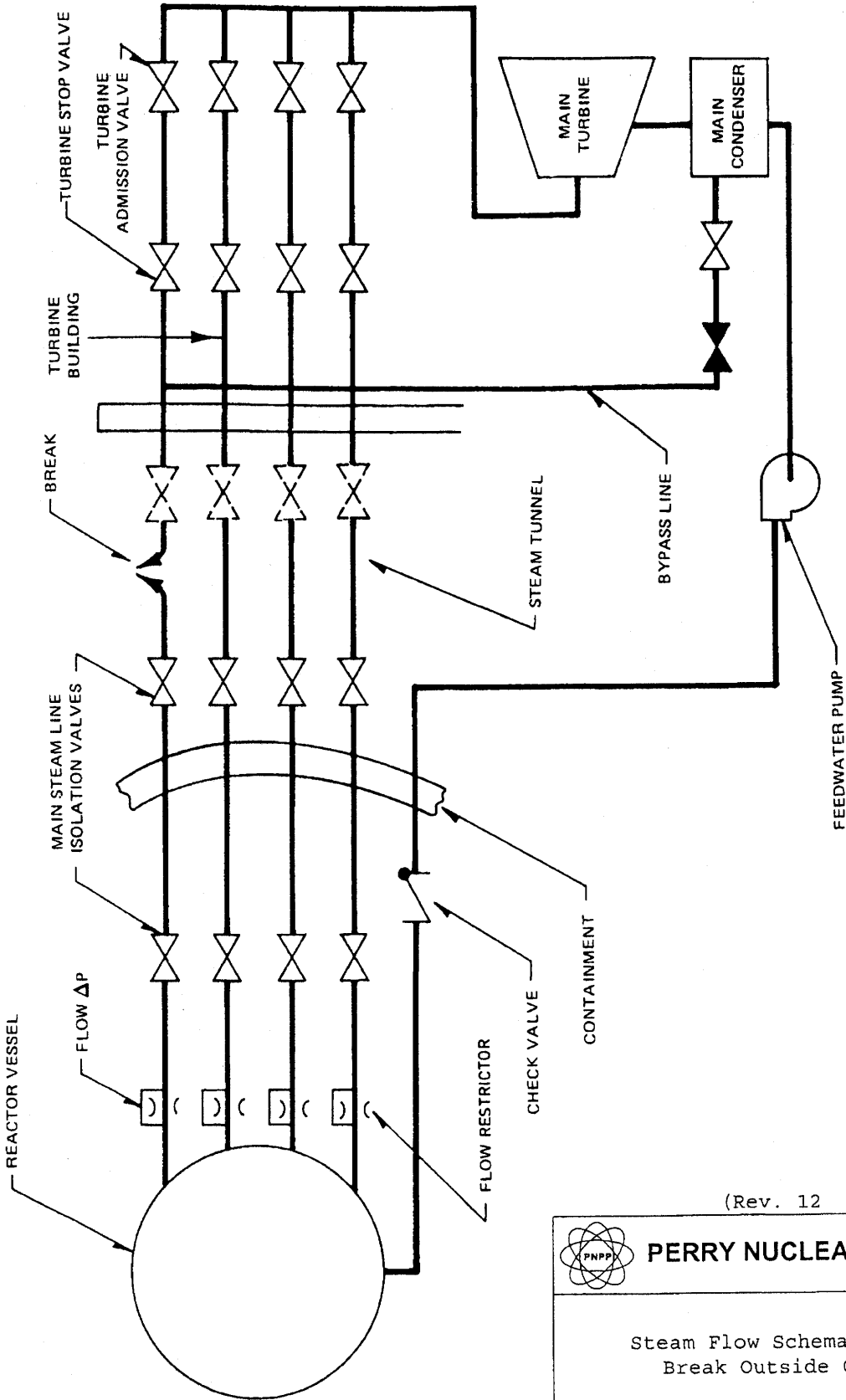

(Rev. 12 1/03)



PERRY NUCLEAR POWER PLANT

Steam Flow Schematic For Steam Break Outside Containment

Figure 15.6-1

Fission Product Transport Model (MSIV and Containment Leakage Pathways)

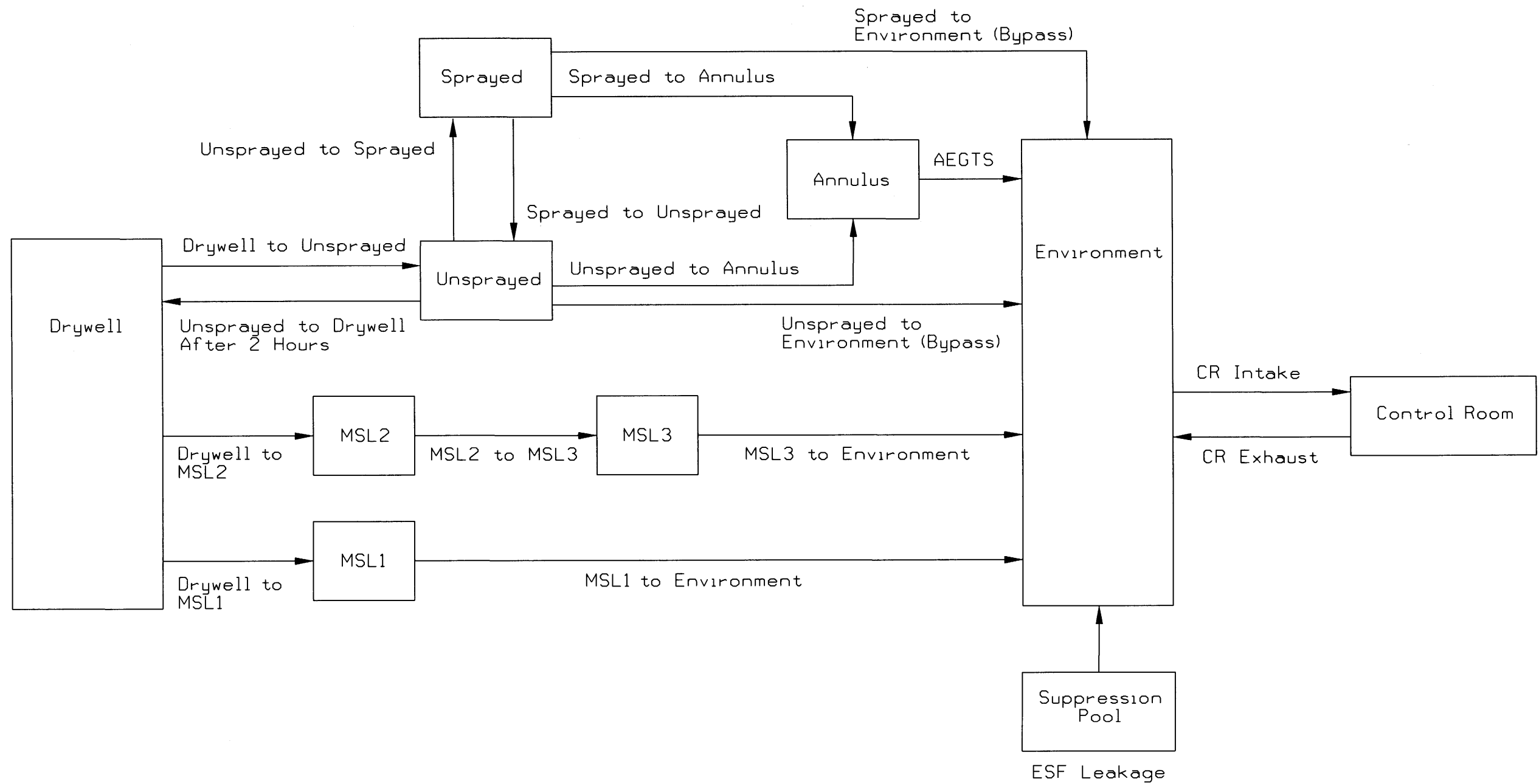

(REV. 19 10/2015)

PERRY NUCLEAR POWER PLANT 10 CENTER RD., PERRY, OHIO 44081
AIR LEAKAGE FLOWPATH POST-LOCA
FIGURE 15.6-2

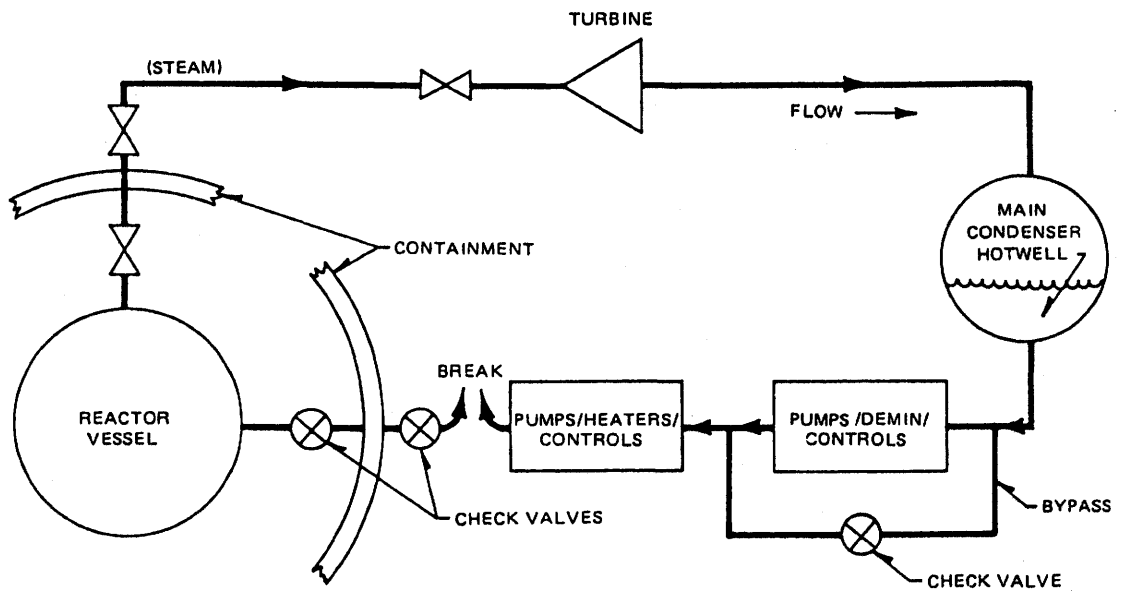

(Rev. 12 1/03)



PERRY NUCLEAR POWER PLANT

Leakage Path for Feedwater Line
Break Outside Containment

Figure 15.6-3

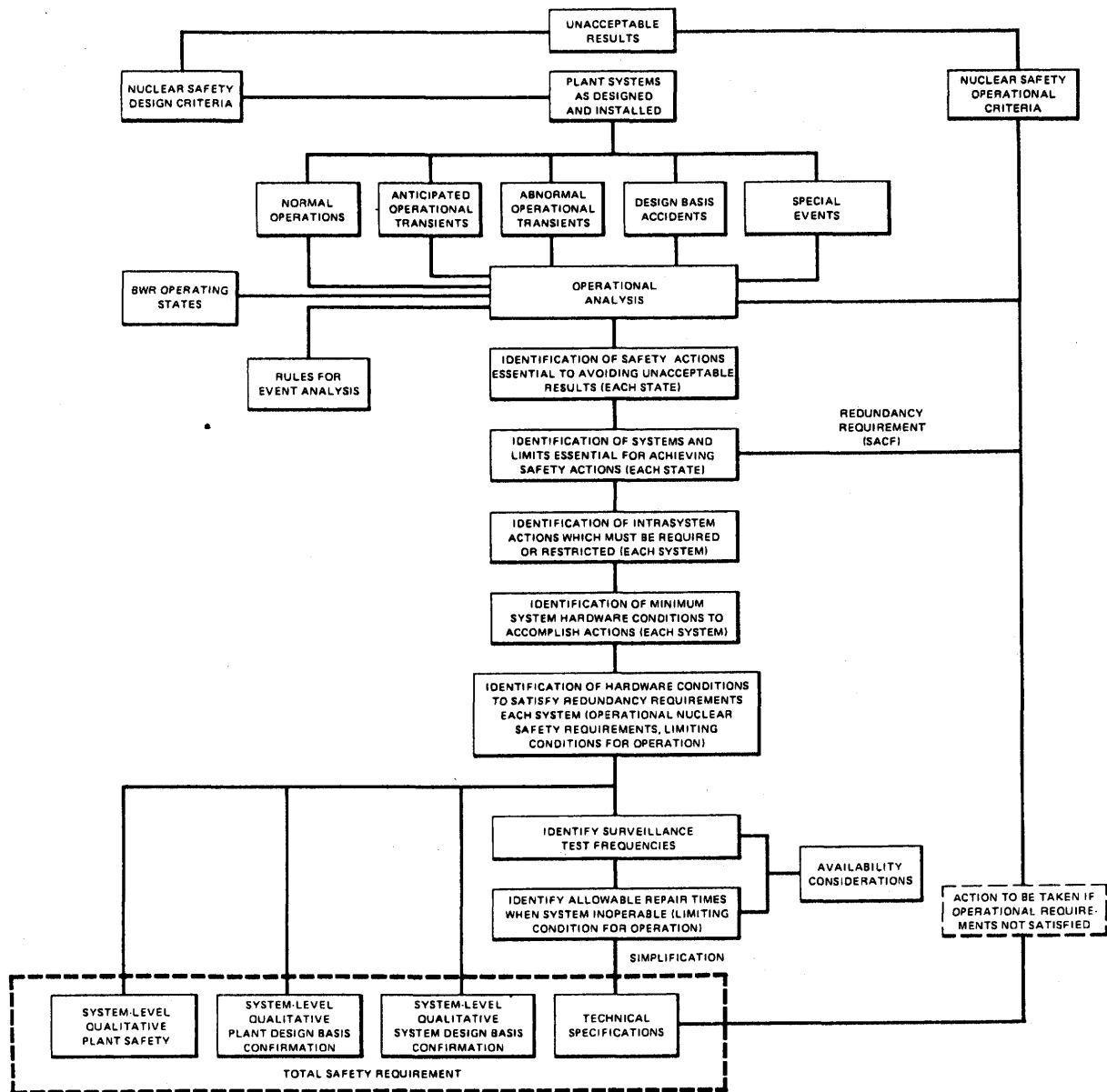

(Rev. 12 1/03)



PERRY NUCLEAR POWER PLANT

Block Diagram Used to Derive Nuclear Safety Operational Requirement System Level Qualitative Design Basis Confirmation Audits and Technical Specifications
Figure 15A.2-1

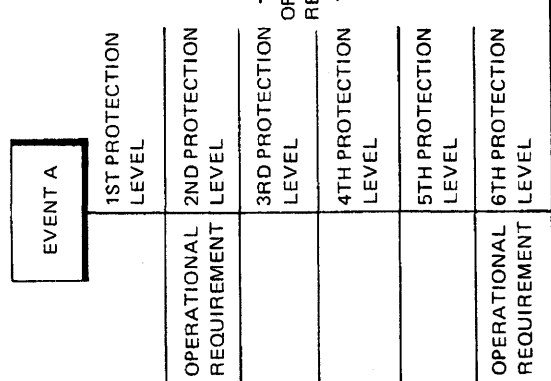
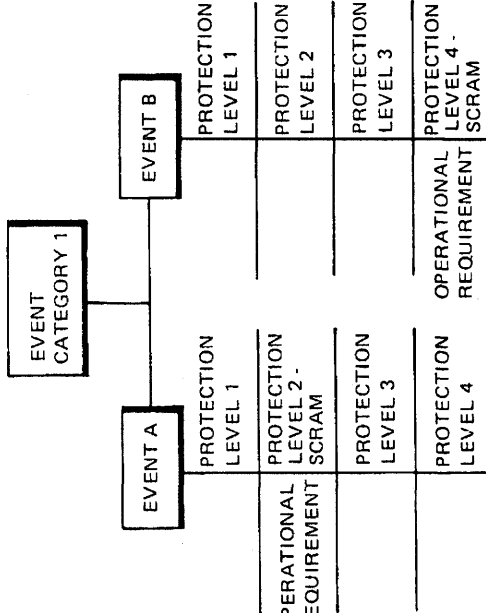
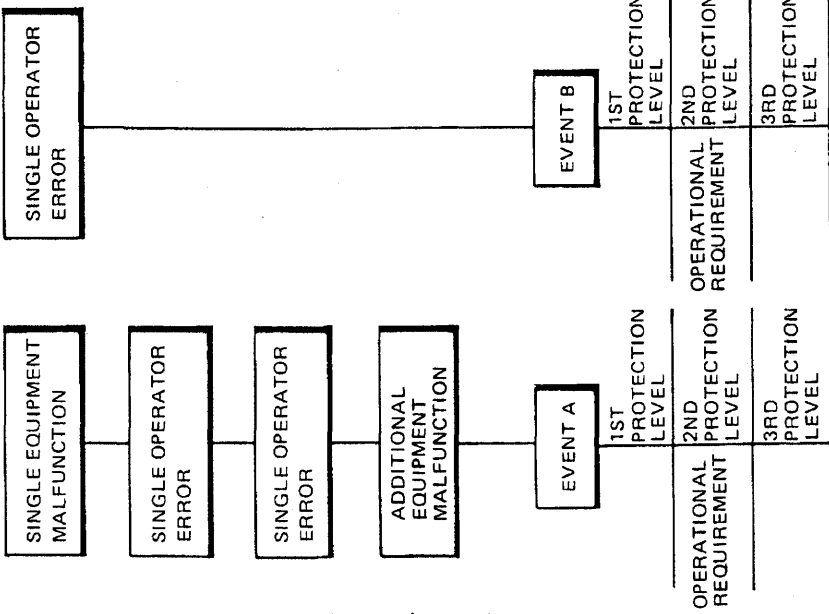

IT IS INCONSISTENT TO PLACE OPERATIONAL REQUIREMENTS ON SEPARATED LEVELS OF PROTECTION FOR ANY ONE EVENT

IT IS INCONSISTENT TO PLACE OPERATIONAL REQUIREMENTS ARBITRARILY ON SOME ACTION (SCRAM) IN ALL CASES OF ONE EVENT CATEGORY. BECAUSE THAT ACTION (SCRAM) MAY REPRESENT DIFFERENT LEVELS OF PROTECTION FOR THE VARIOUS CASES.

PANEL B

PANEL A

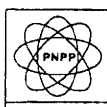

PERRY NUCLEAR POWER PLANT

Possible Inconsistencies in the Selection of Nuclear Safety Operational Requirements

Figure 15A.2-2

PANEL B

PANEL A

(Rev. 12 1/03)

IT IS INCONSISTENT TO PLACE OPERATIONAL REQUIREMENTS ON EVEN THE SAME LEVELS OF PROTECTION. IF THE EVENTS ARE NOT OF THE SAME CATEGORY.

PANEL C

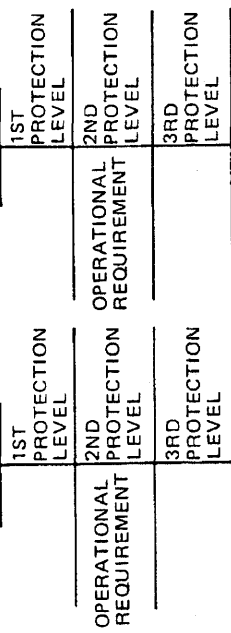

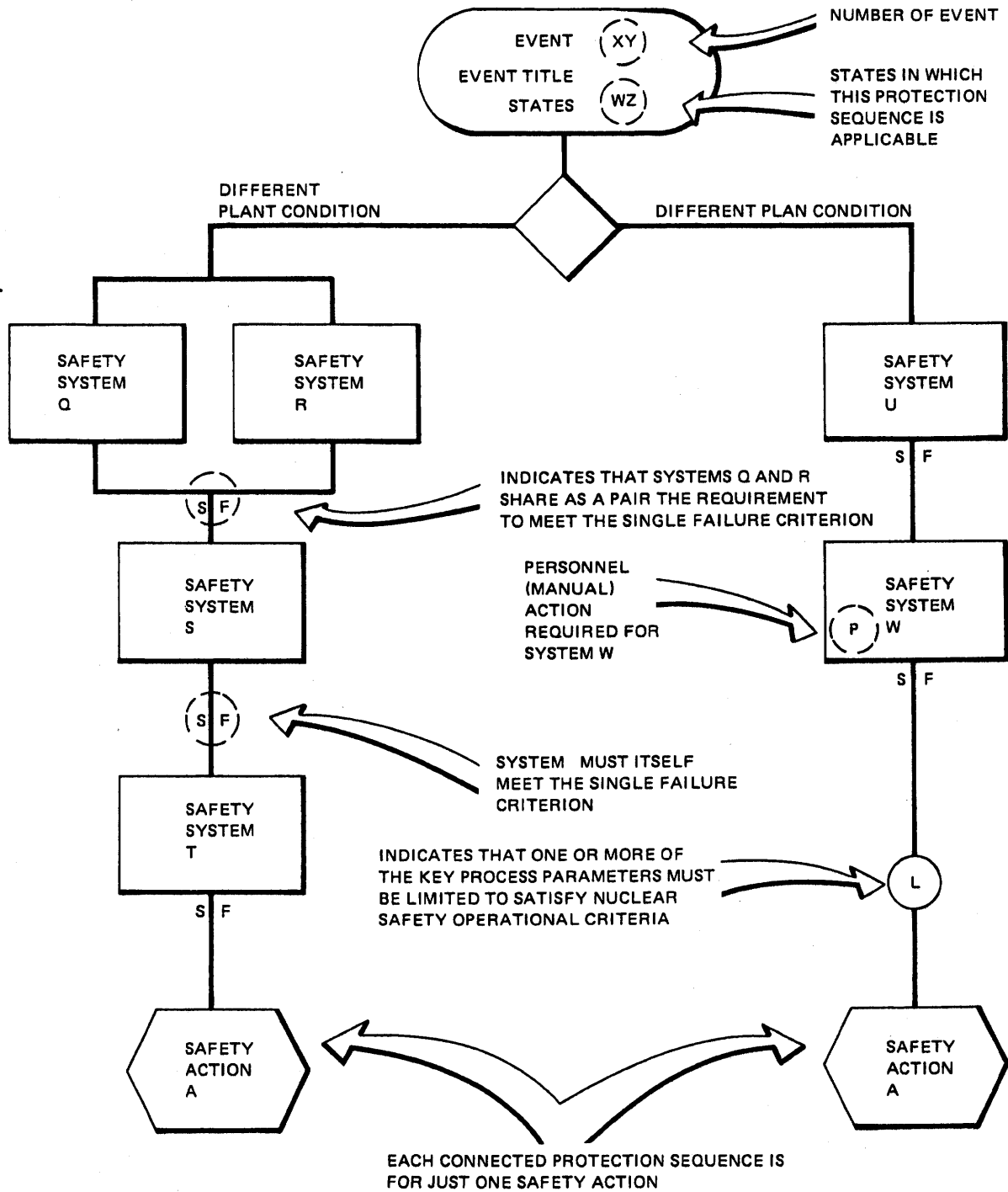

(Rev. 12 1/03)



PERRY NUCLEAR POWER PLANT

Format for Protection
Sequence Diagrams

Figure 15A.4-1

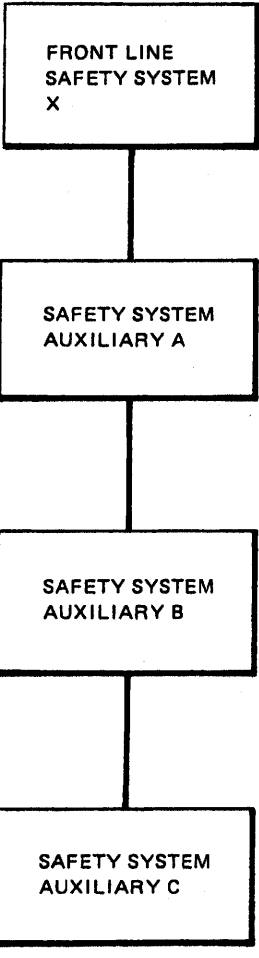
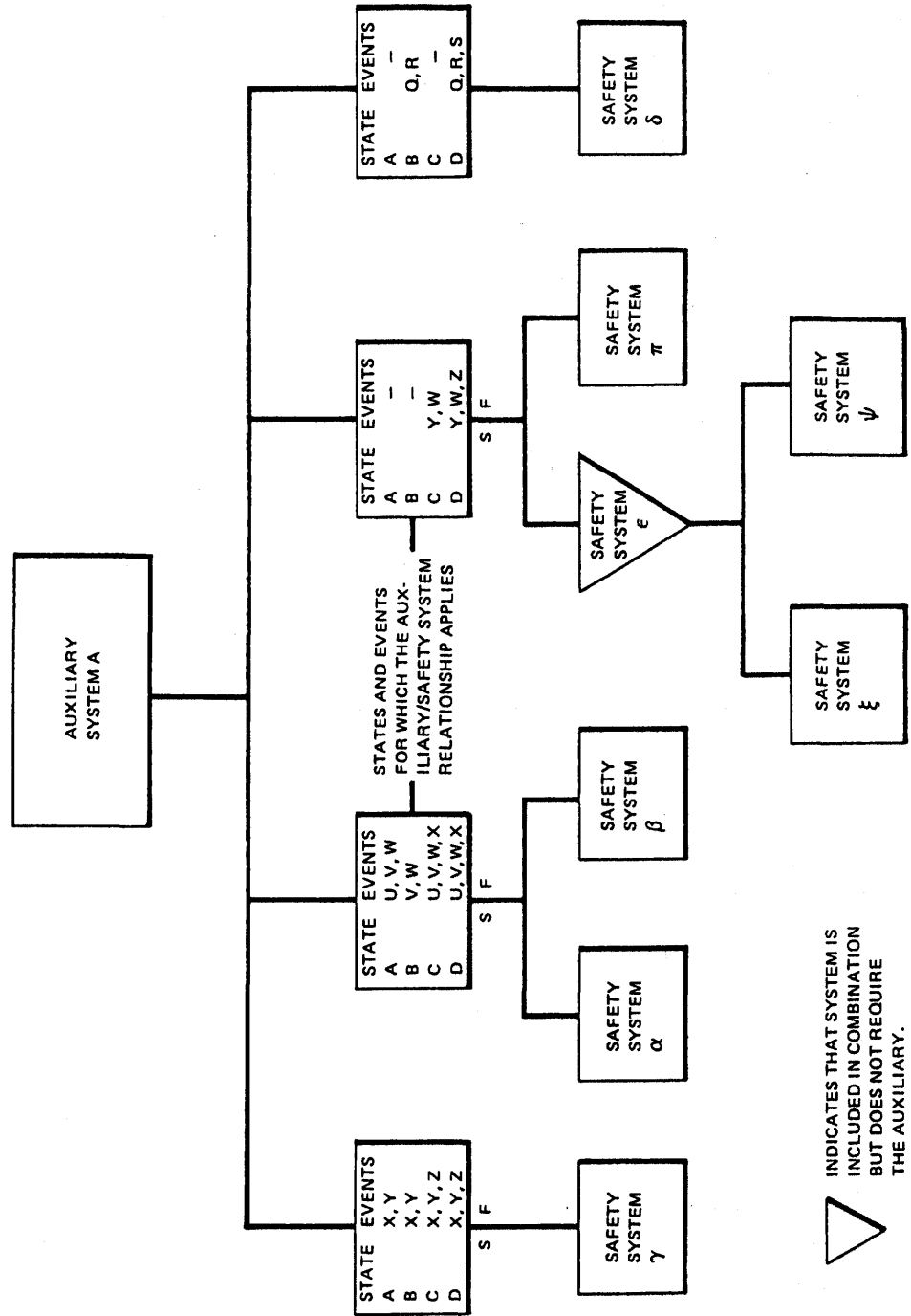



DIAGRAM INDICATES THAT AUXILIARIES A, B, AND C ARE ESSENTIAL TO THE OPERATION OF THE FRONT LINE SAFETY SYSTEM X. NO CHRONOLOGY OR ORDER OF ACTION IS IMPLIED

(Rev. 12 1/03)

	PERRY NUCLEAR POWER PLANT
Format for Safety System Auxiliary Diagrams	
Figure 15A.4-2	



(Rev. 12 1/03)

 **PERRY NUCLEAR POWER PLANT**

Format for Commonality of
 Auxiliary Diagrams

Figure 15A.4-3

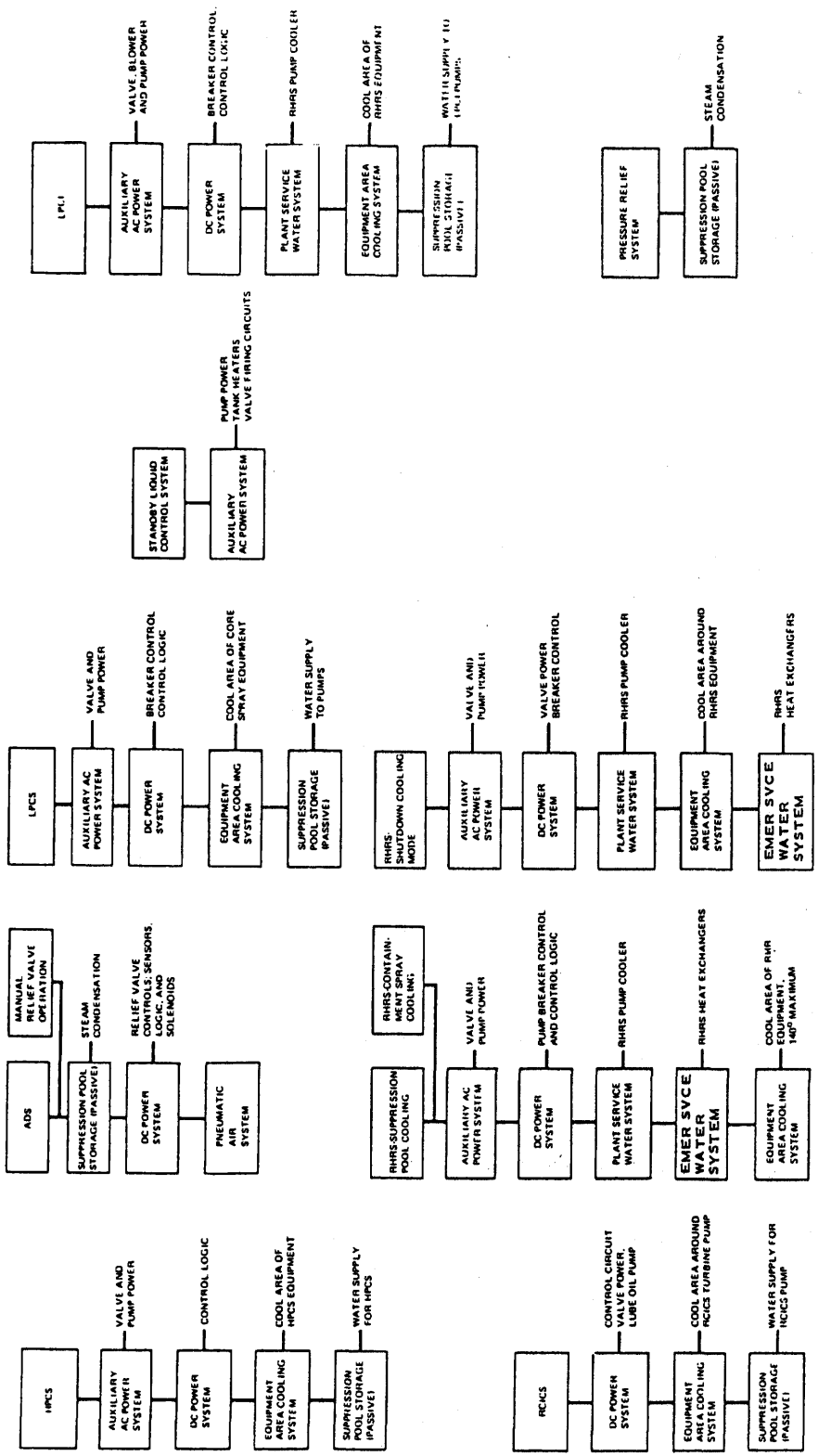

(Rev. 12 1/03)

PERRY NUCLEAR POWER PLANT

Safety System Auxiliaries

Figure 15A.6-1

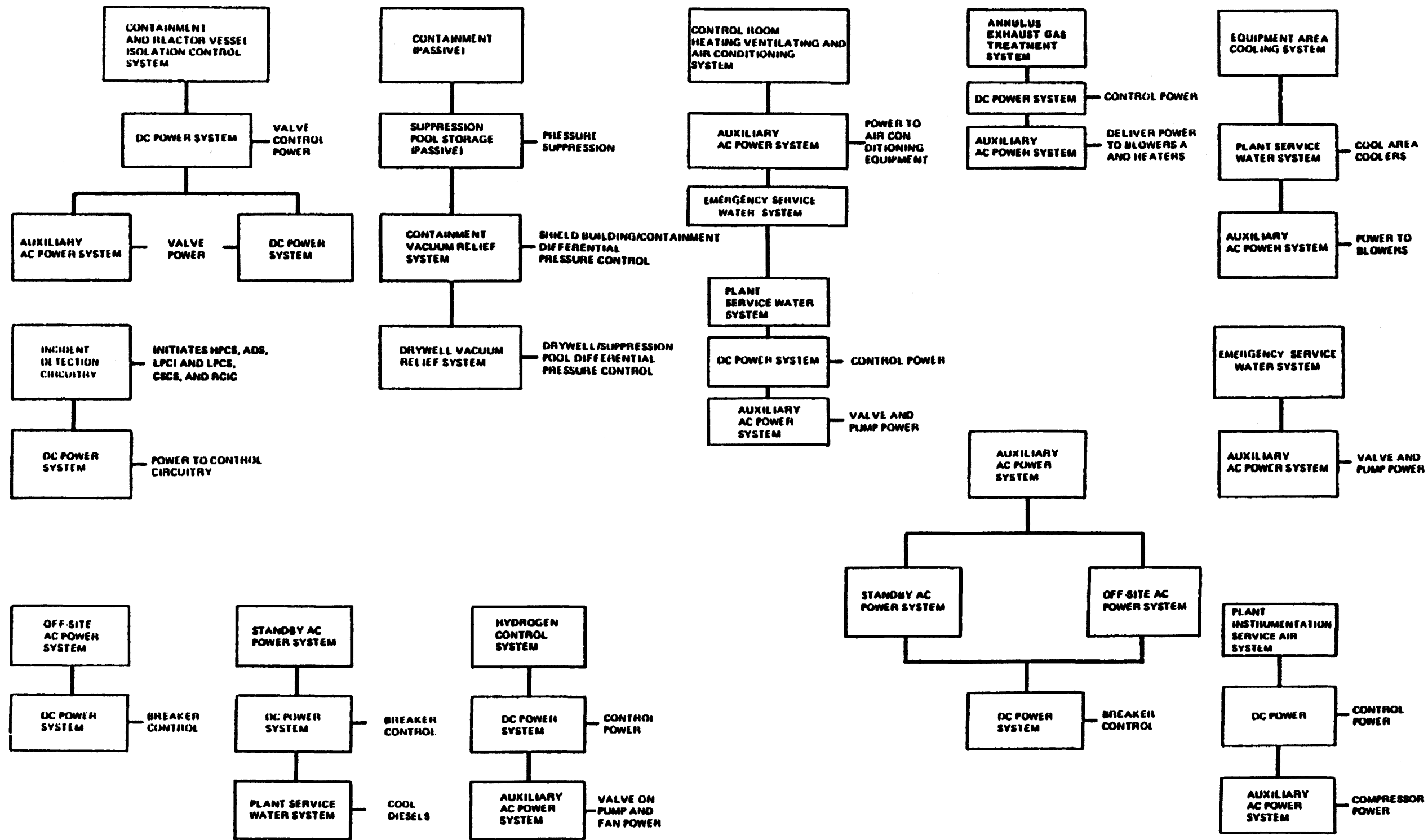

(REV. 19 10/2015)

PERRY NUCLEAR POWER PLANT
10 CENTER RD., PERRY, OHIO 44081

SAFETY SYSTEM AUXILIARIES

FIGURE 15A.6-2

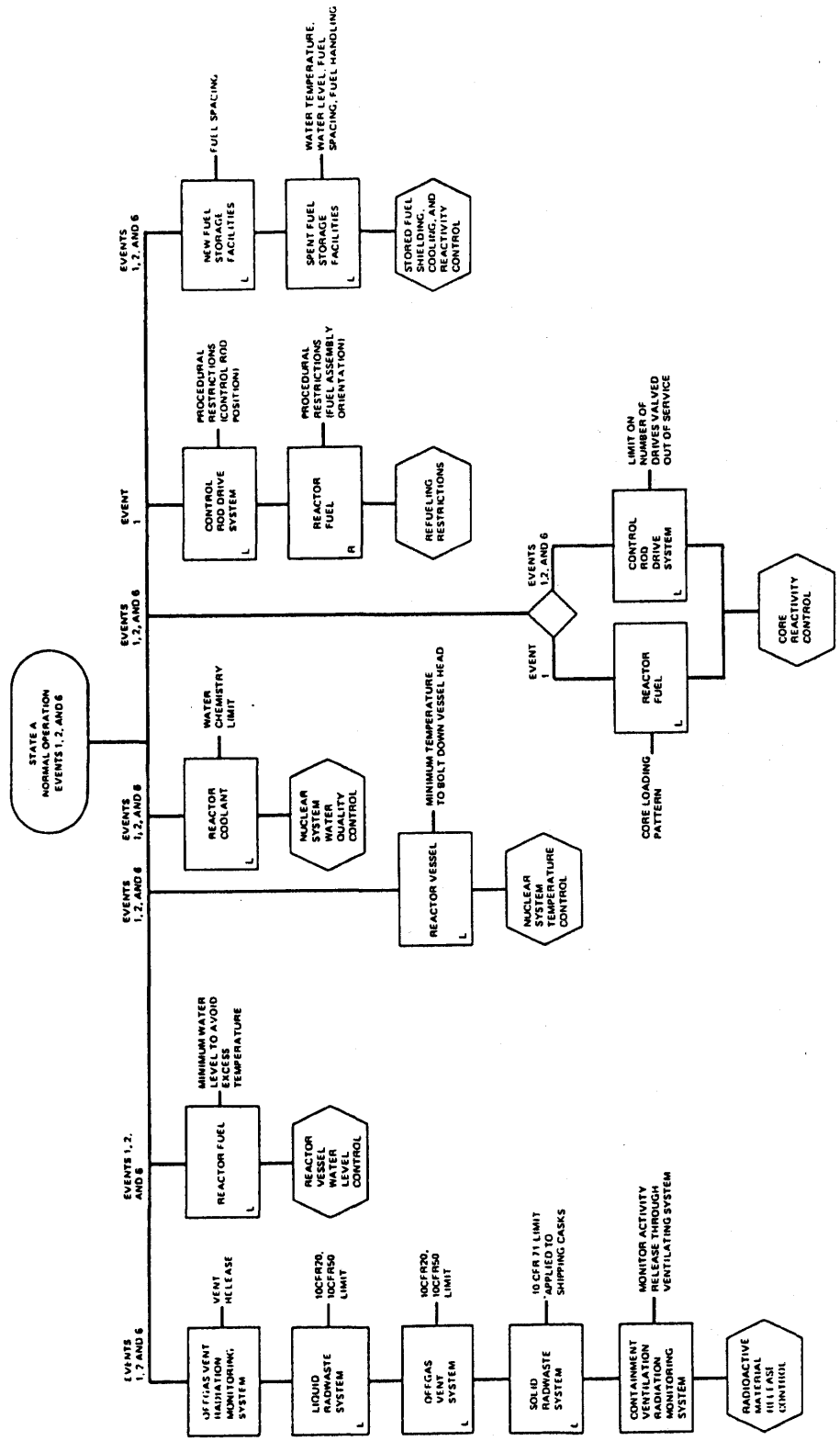

(Rev. 12 1/03)

PERRY NUCLEAR POWER PLANT

Safety Action Sequences for
Normal Operation in State A.

Figure 15A.6-3

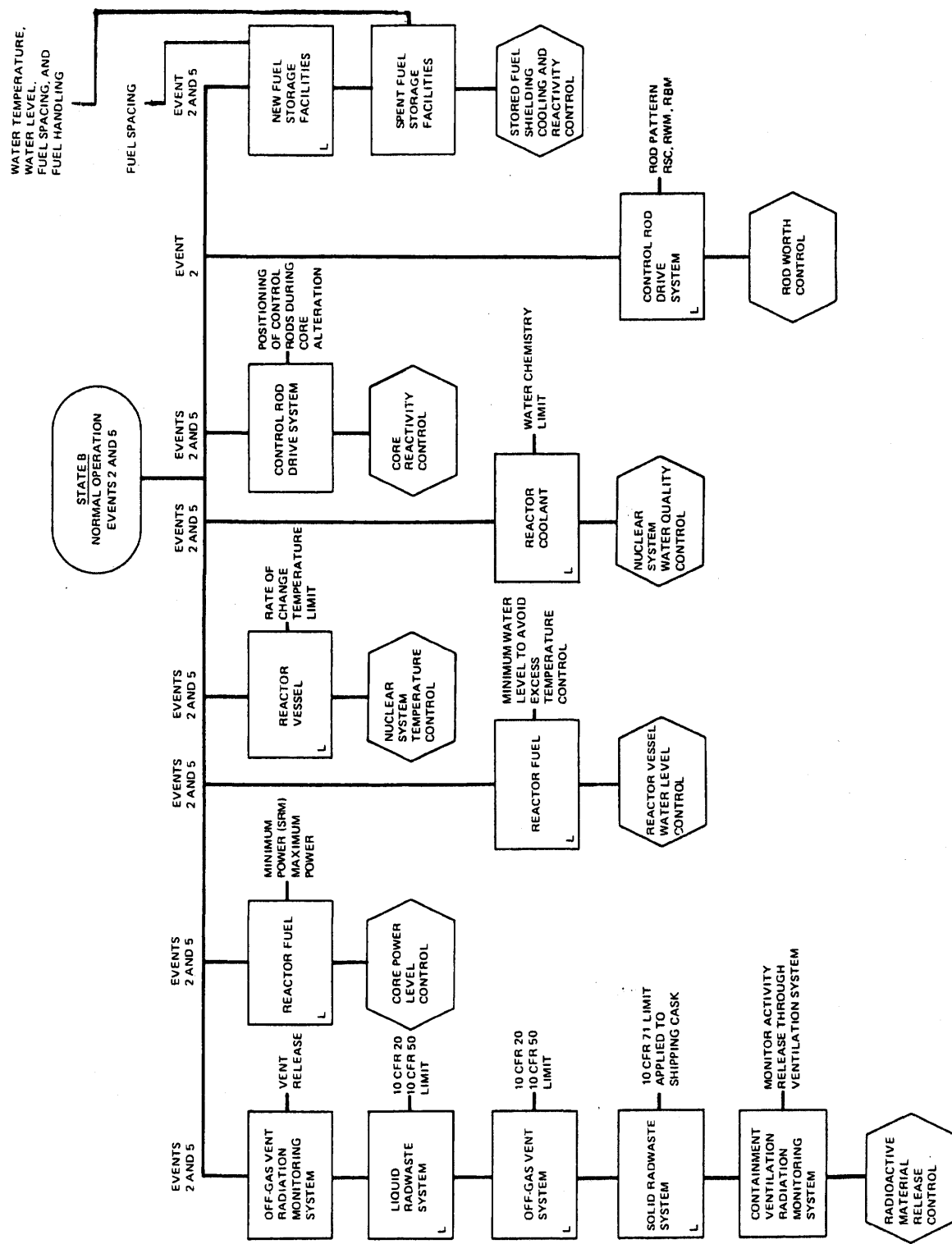

(Rev. 12 1/03)



PERRY NUCLEAR POWER PLANT

Safety Action Sequences for
Normal Operation in State B.

Figure 15A.6-4

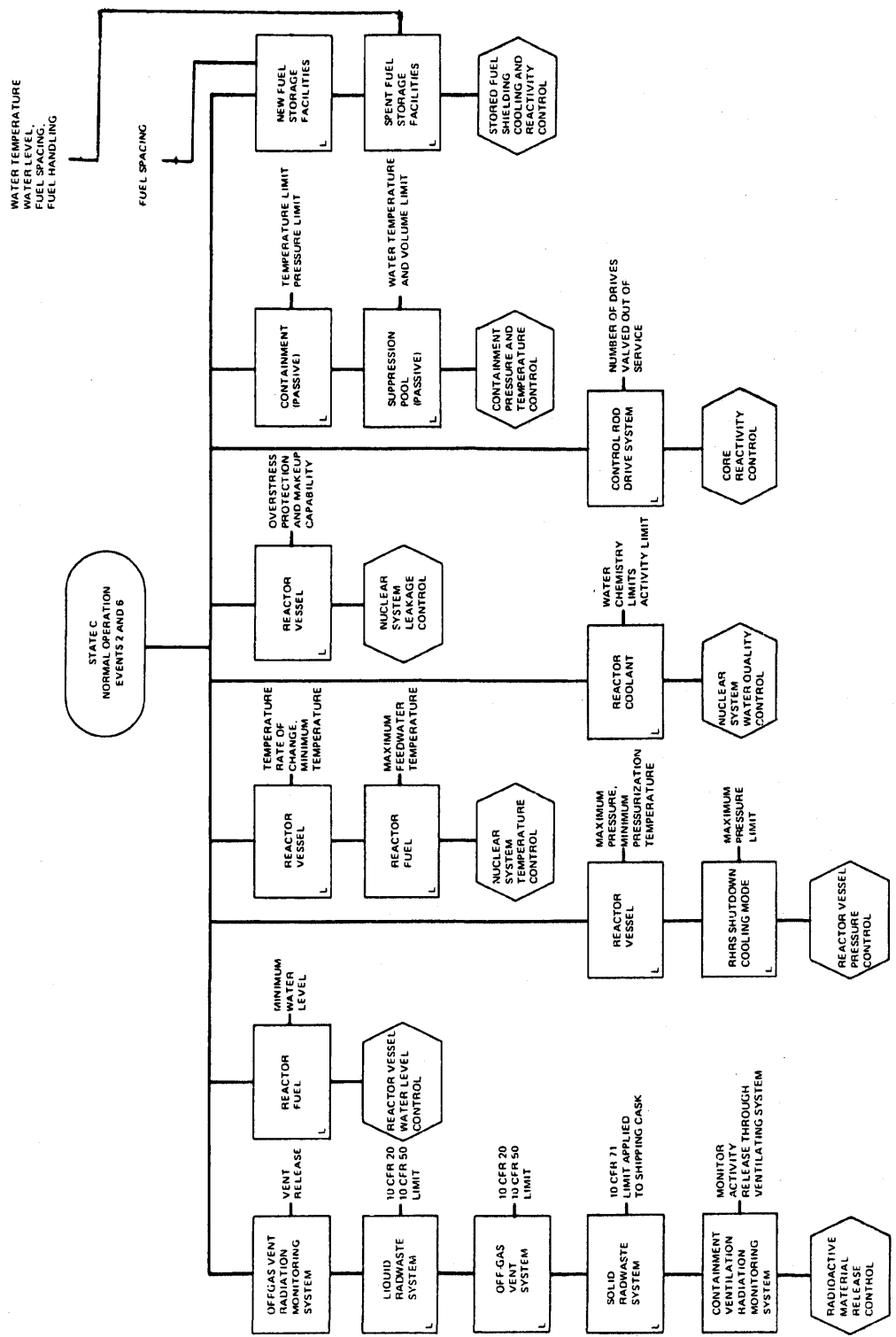

(Rev. 12 1/03)

PERRY NUCLEAR POWER PLANT

Safety Action Sequences for
Normal Operation in State C.

Figure 15A.6-5

EVENT 7
MANUAL OR
INADVERTENT
SCRAM
STATES A, B, C, D

REACTOR
PROTECTION
SYSTEM

S F

CONTROL ROD
DRIVE SYSTEM

S F

SCRAM

(Rev. 12 1/03)

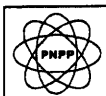
	PERRY NUCLEAR POWER PLANT
Protection Sequence for Manual or Inadvertent Scram Figure 15A.6-7	

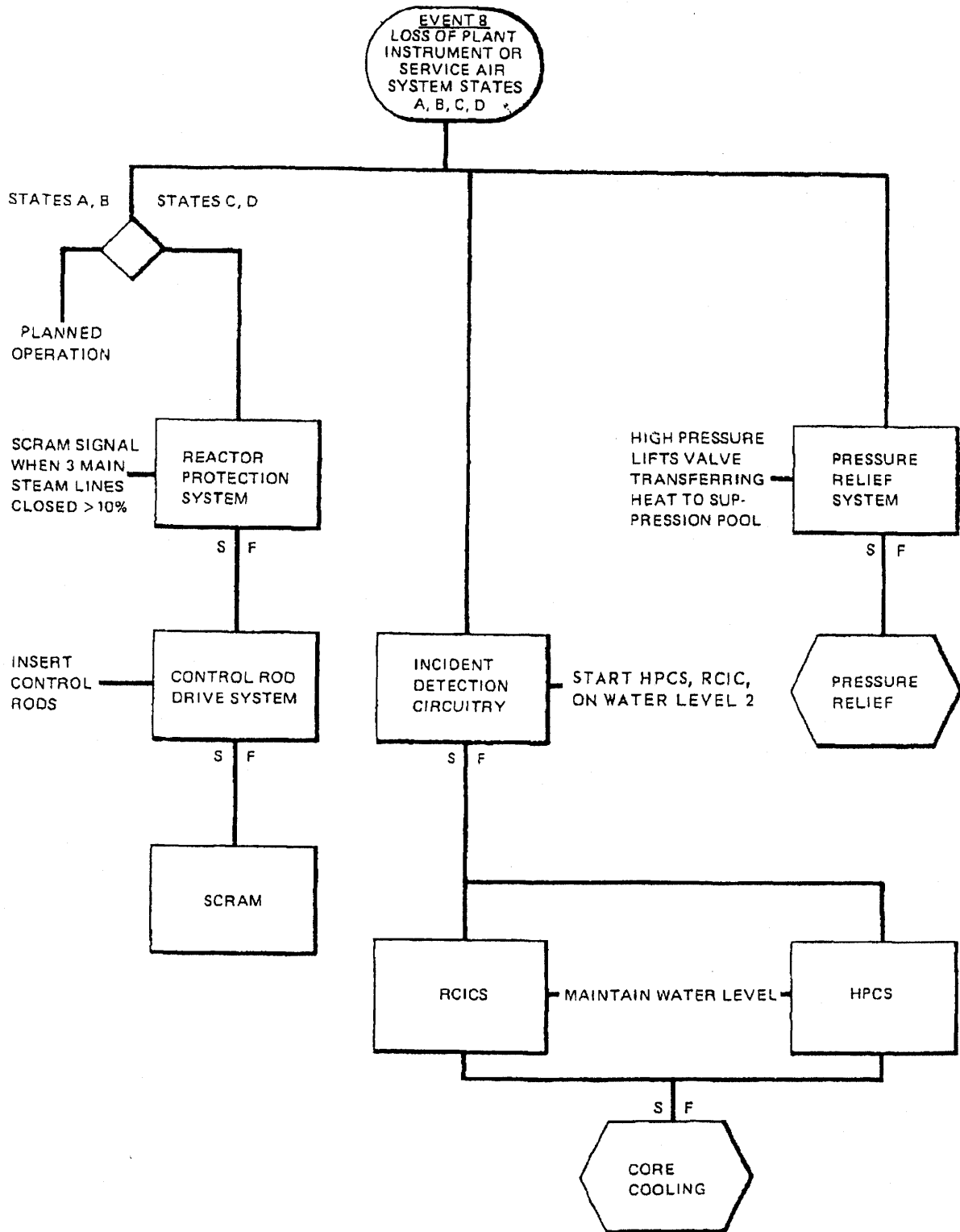

(Rev. 12 1/03)

	PERRY NUCLEAR POWER PLANT
Protective Sequence for Loss of Plant Instrument or Service Air System	
Figure 15A.6-8	

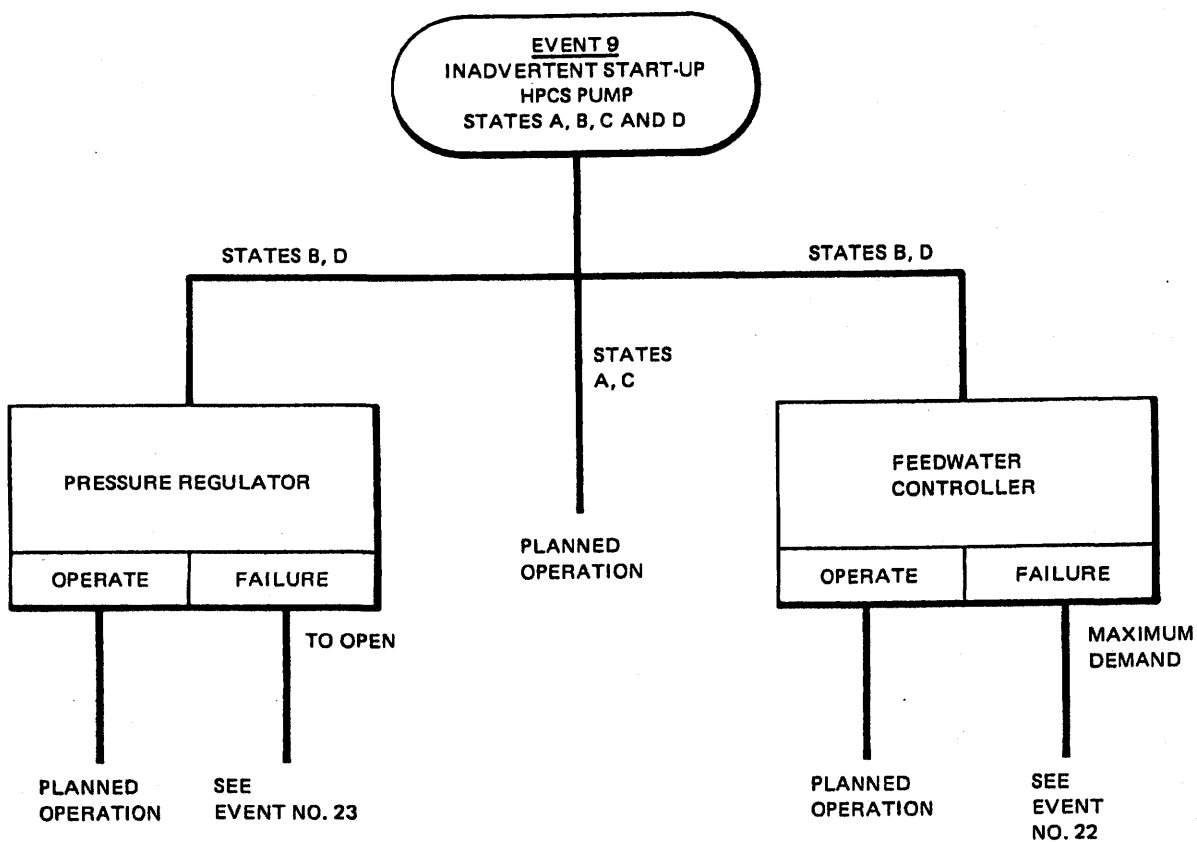

(Rev. 12 1/03)



PERRY NUCLEAR POWER PLANT

Protective Sequence for
Inadvertent Startup of HPCS Pumps

Figure 15A.6-9

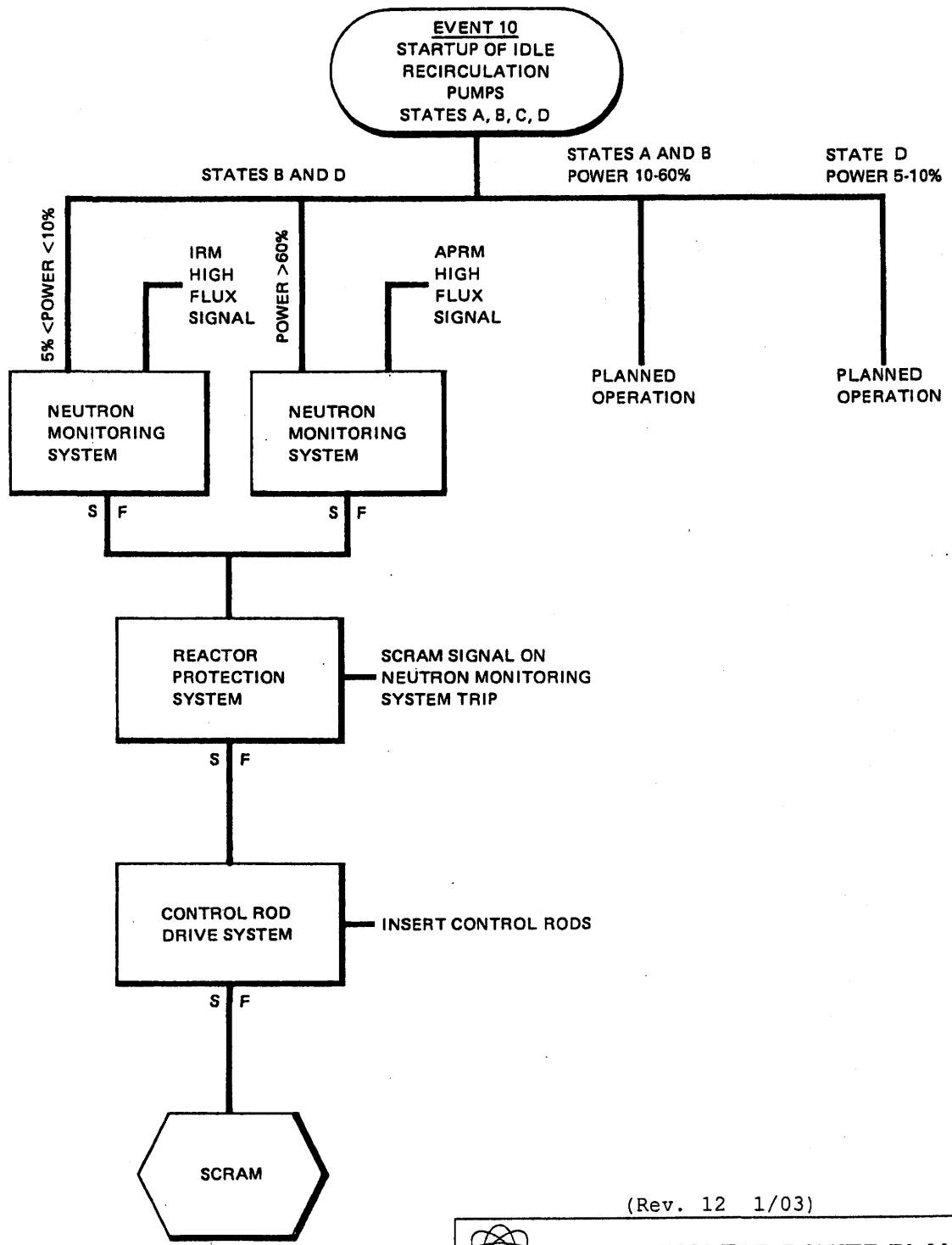

(Rev. 12 1/03)



PERRY NUCLEAR POWER PLANT

Protective Sequence for Inadvertent
Startup of Idle
Recirculation Loop Pump

Figure 15A.6-10

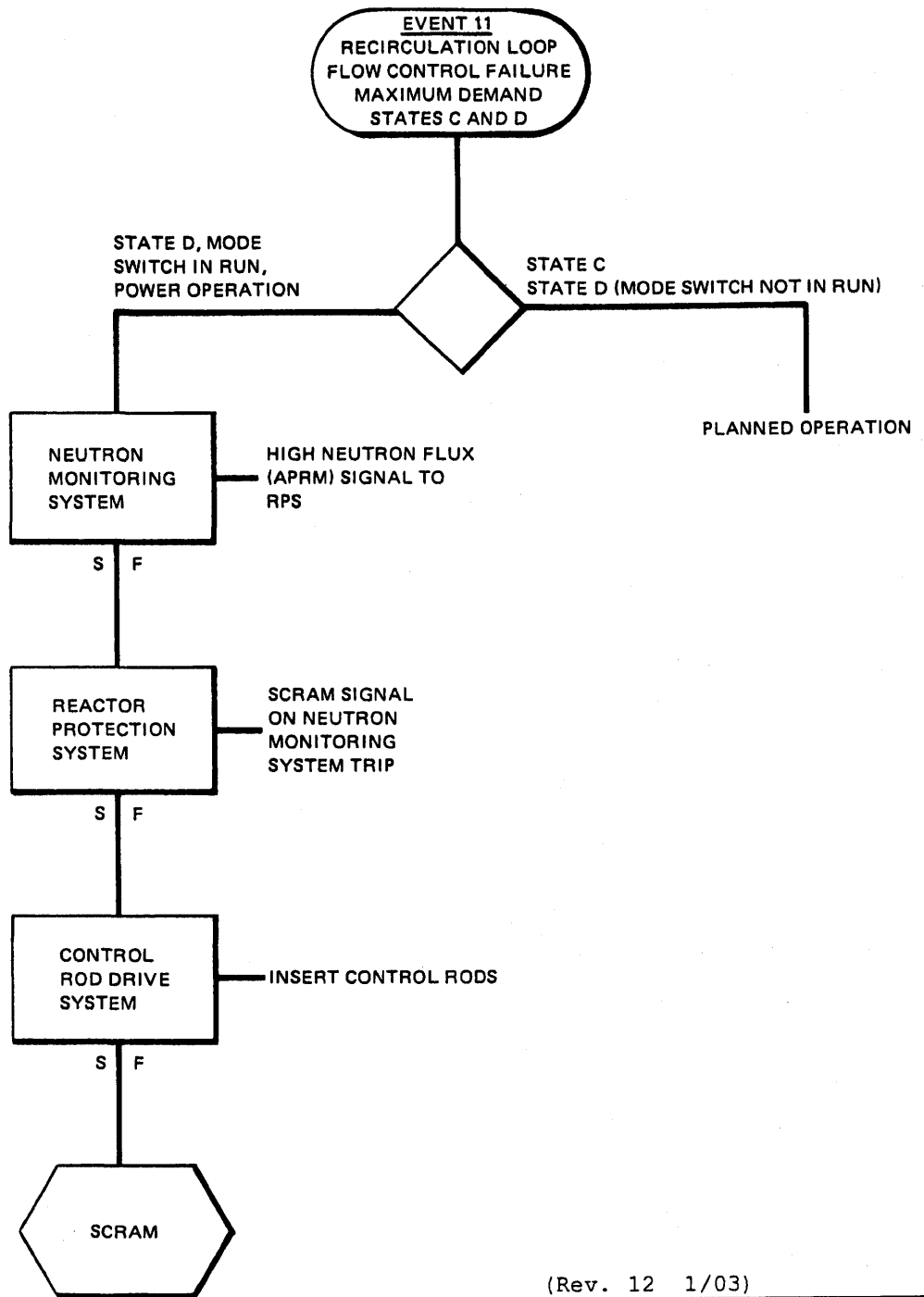

(Rev. 12 1/03)



PERRY NUCLEAR POWER PLANT

Protective Sequence for
Recirculation Loop Flow Control
Failure - Maximum Demand

Figure 15A.6-11

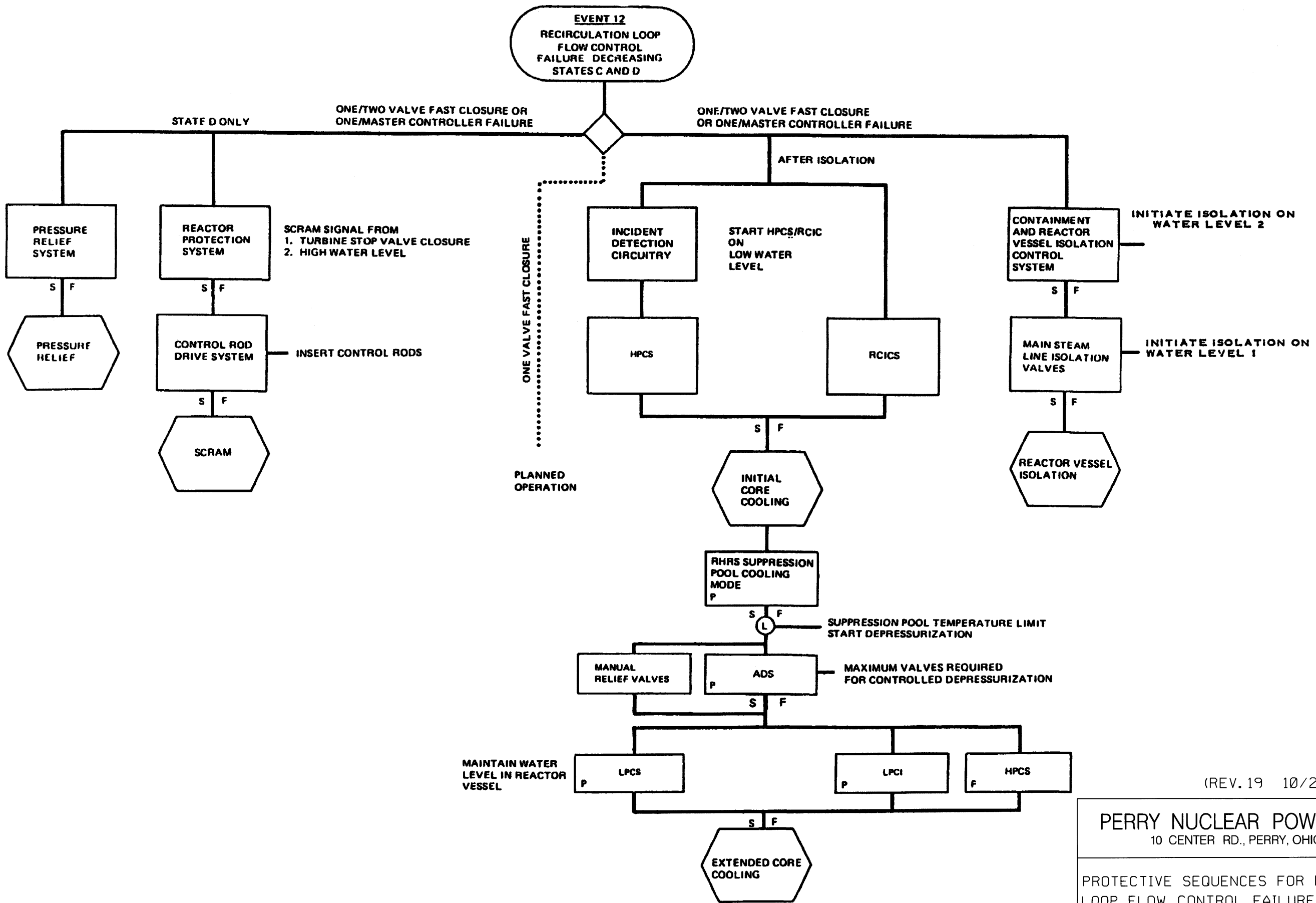

(REV. 19 10/2015)

PERRY NUCLEAR POWER PLANT
 10 CENTER RD., PERRY, OHIO 44081

PROTECTIVE SEQUENCES FOR RECIRCULATION
 LOOP FLOW CONTROL FAILURE - DECREASING

FIGURE 15A.6-12

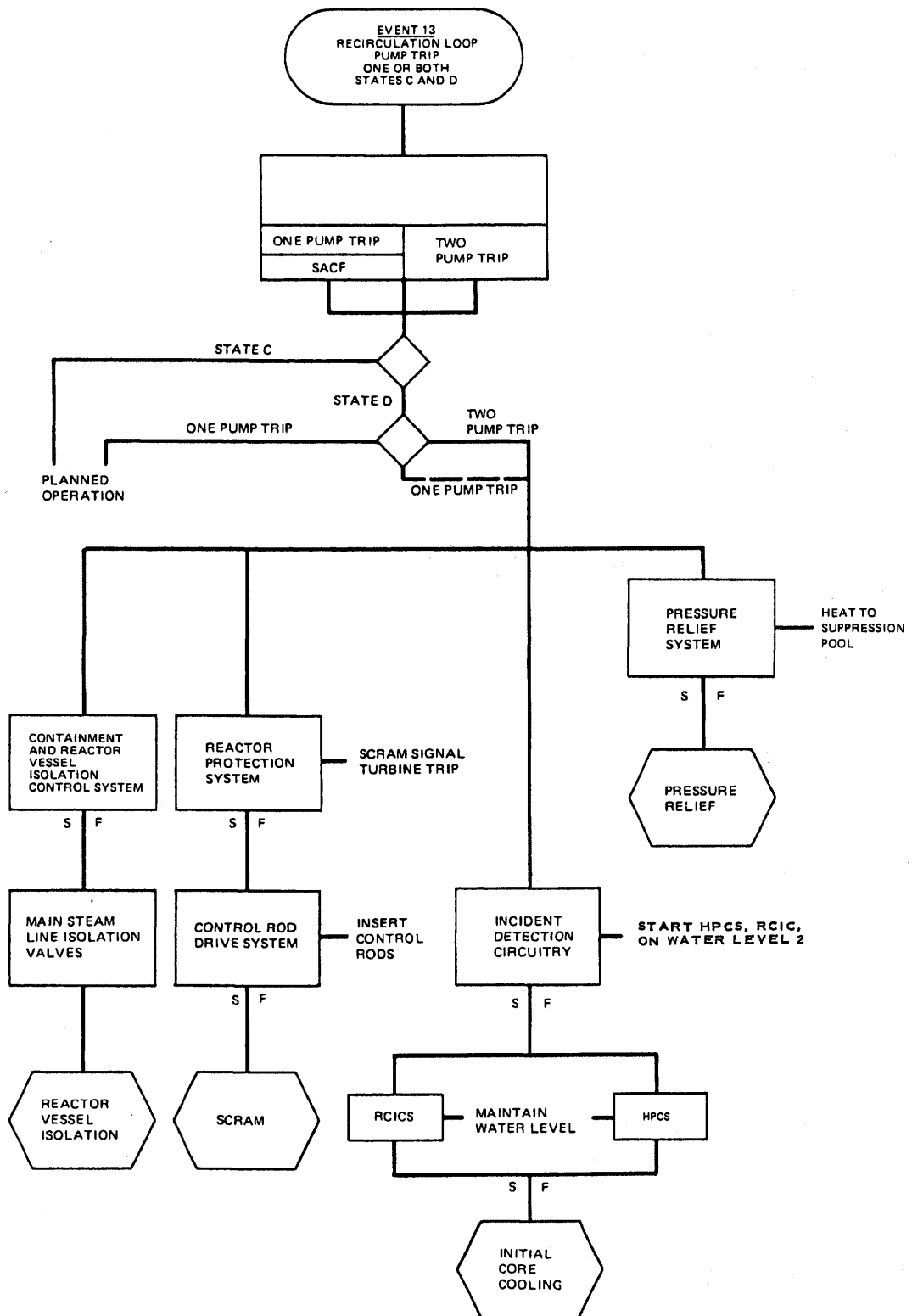

(Rev. 12 1/03)



PERRY NUCLEAR POWER PLANT

Recirculation Loop Pump Trip -
one or both

Figure 15A.6-13

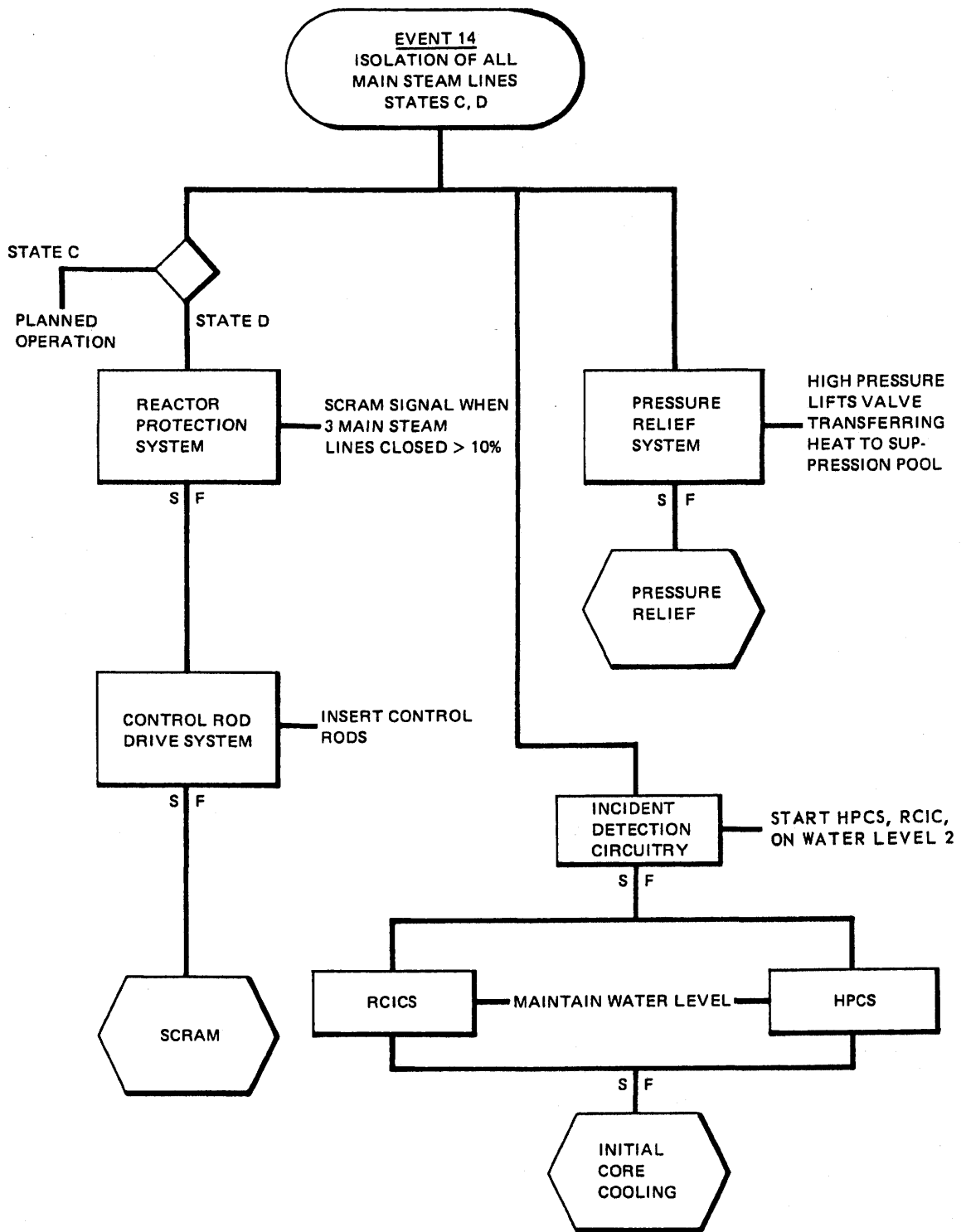

(Rev. 12 1/03)



PERRY NUCLEAR POWER PLANT

Protective Sequence for Isolation
of All Main Steam Lines

Figure 15A.6-14 (Sheet 1 of 2)

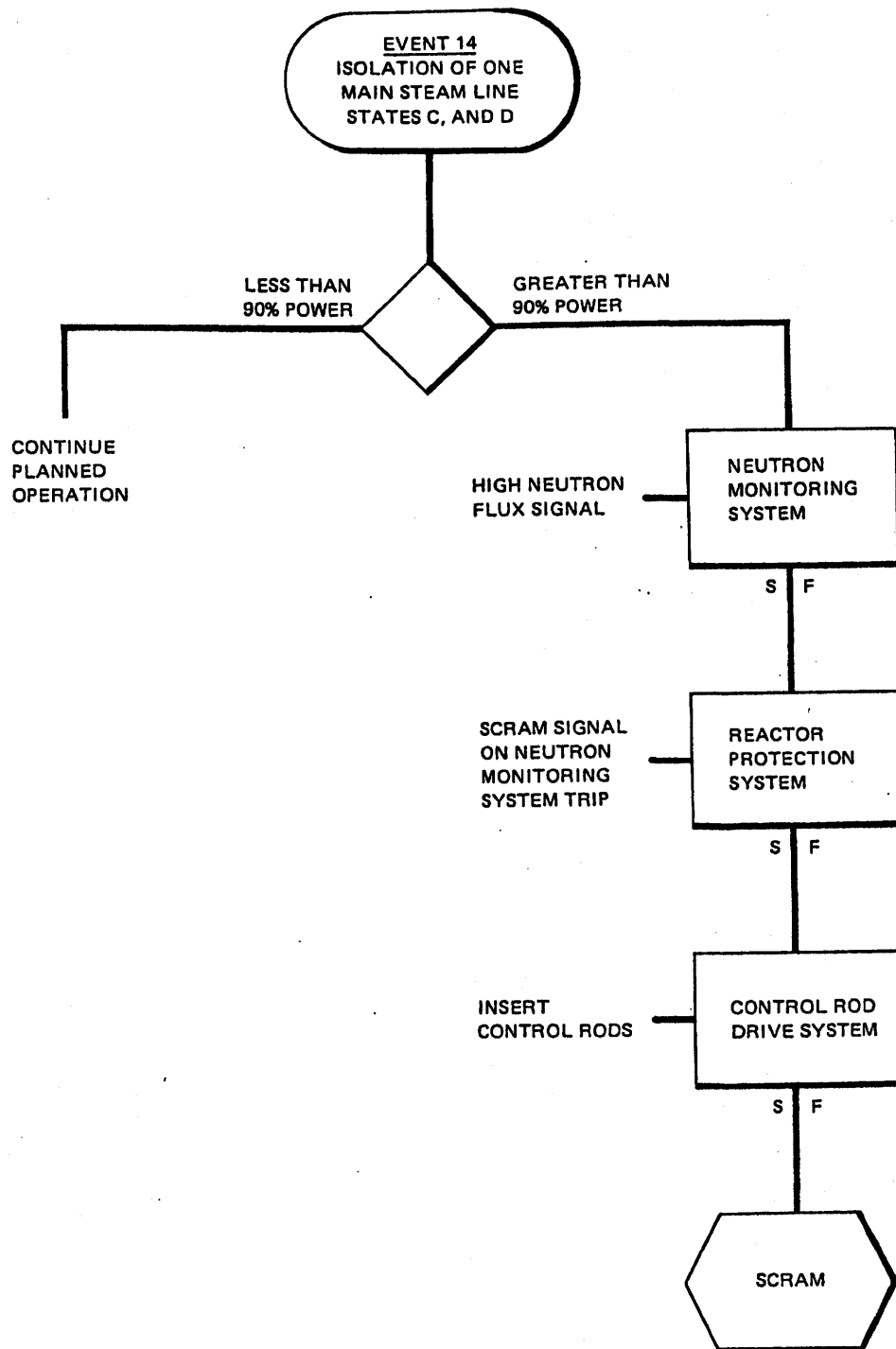

(Rev. 12 1/03)



PERRY NUCLEAR POWER PLANT

Protective Sequence for Isolation
of One Main Steam Line

Figure 15A.6-14 (Sheet 2 of 2)

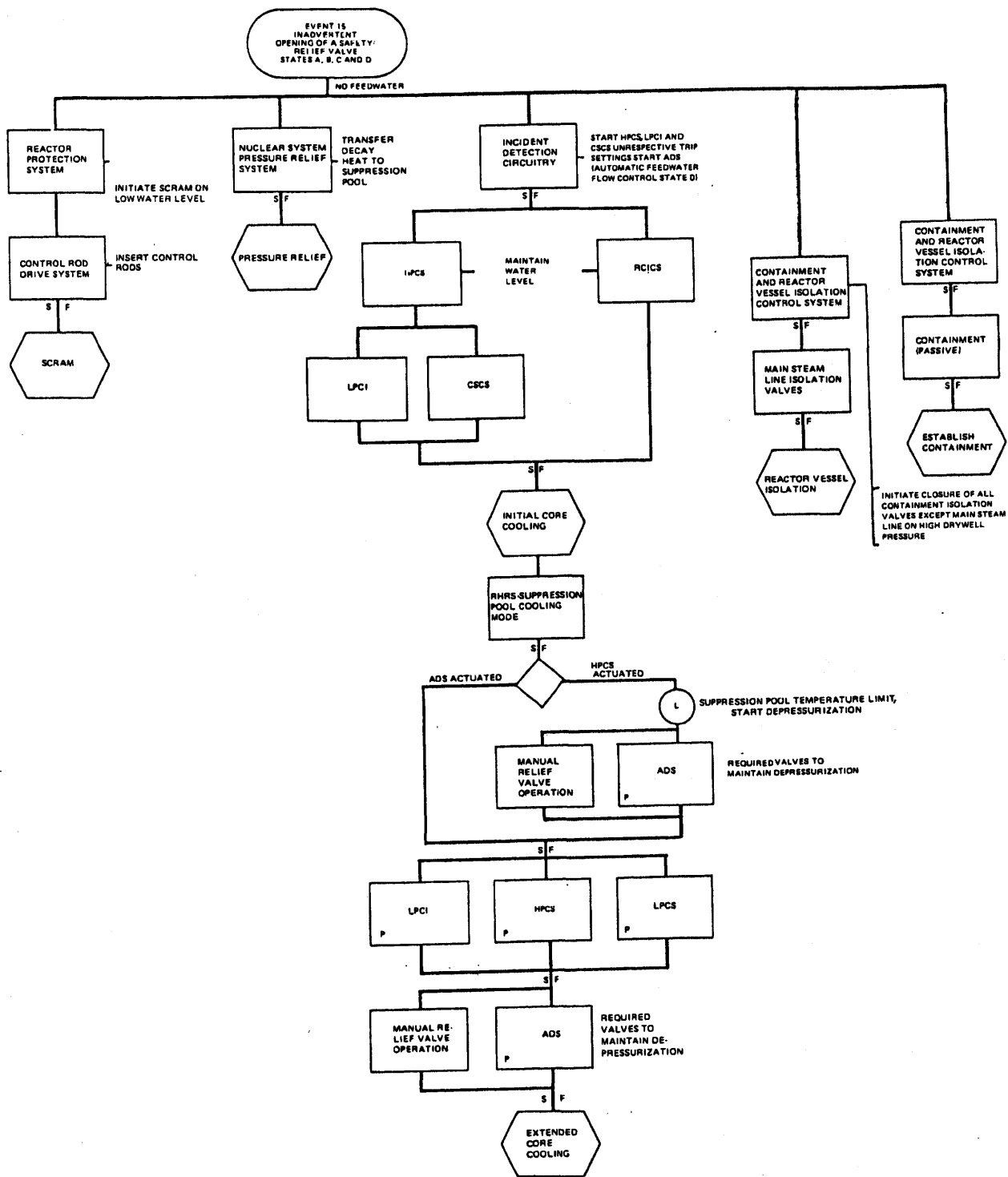

(Rev. 12 1/03)

PERRY NUCLEAR POWER PLANT

Protective Sequences for
Inadvertent Opening of a Safety/
Relief Valve

Figure 15A.6-15

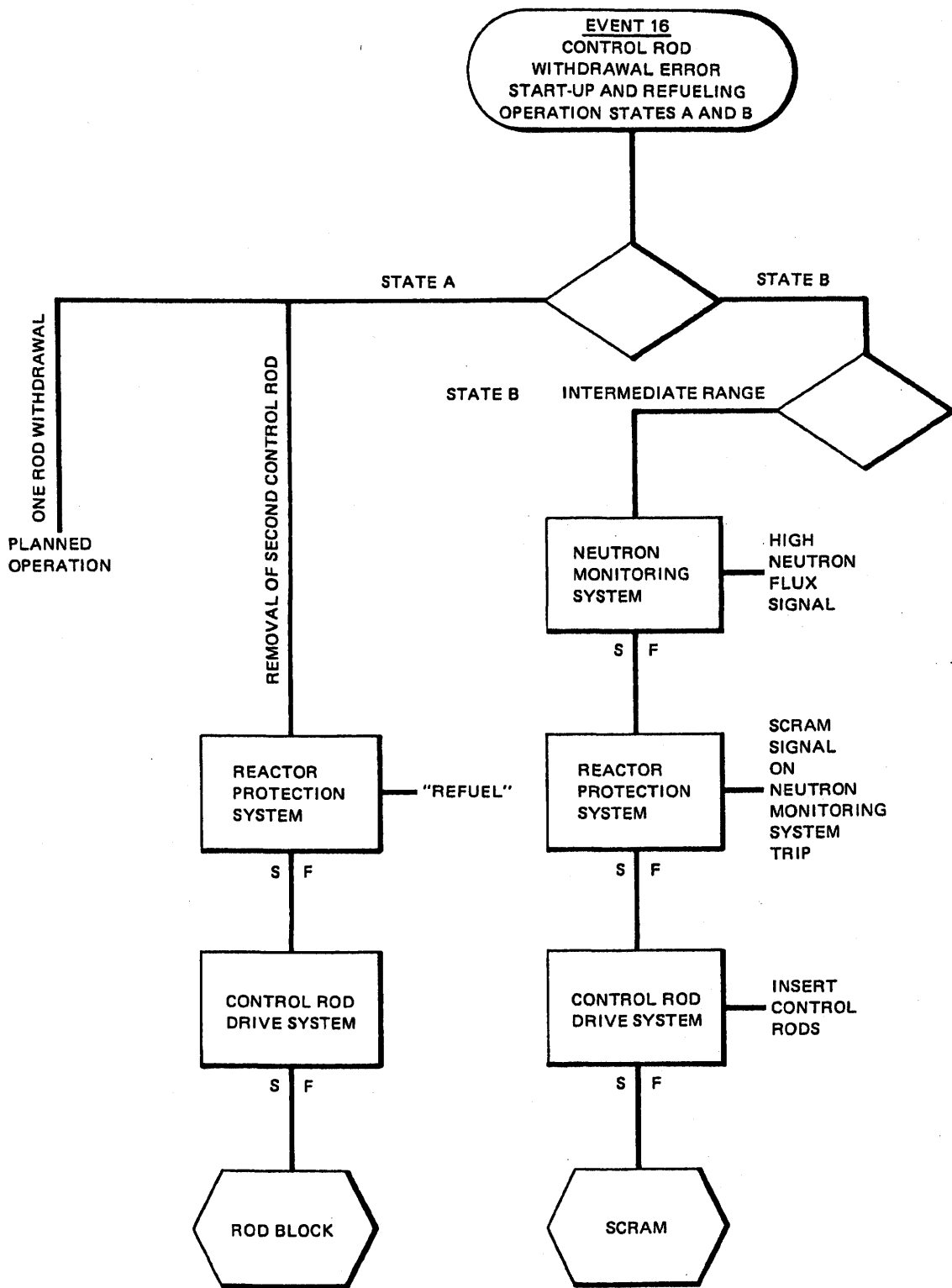

(Rev. 12 1/03)



PERRY NUCLEAR POWER PLANT

Protective Sequence for Control Rod
Withdrawal Error for Startup and
Refueling Operations

Figure 15A.6-16

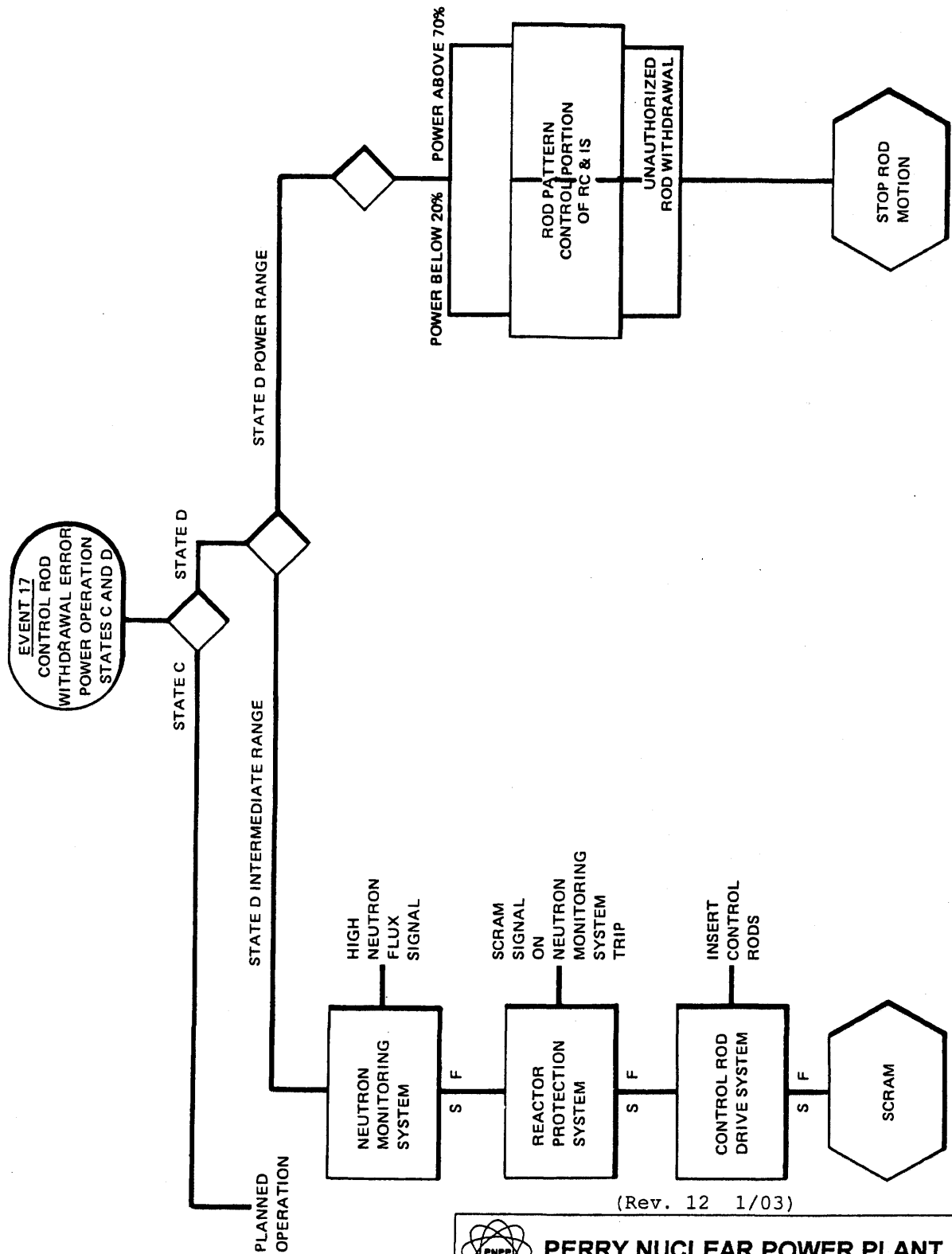

(Rev. 12 1/03)

PERRY NUCLEAR POWER PLANT

Protective Sequence for Control Rod
Withdrawal Error for
Power Operation

Figure 15A.6-17

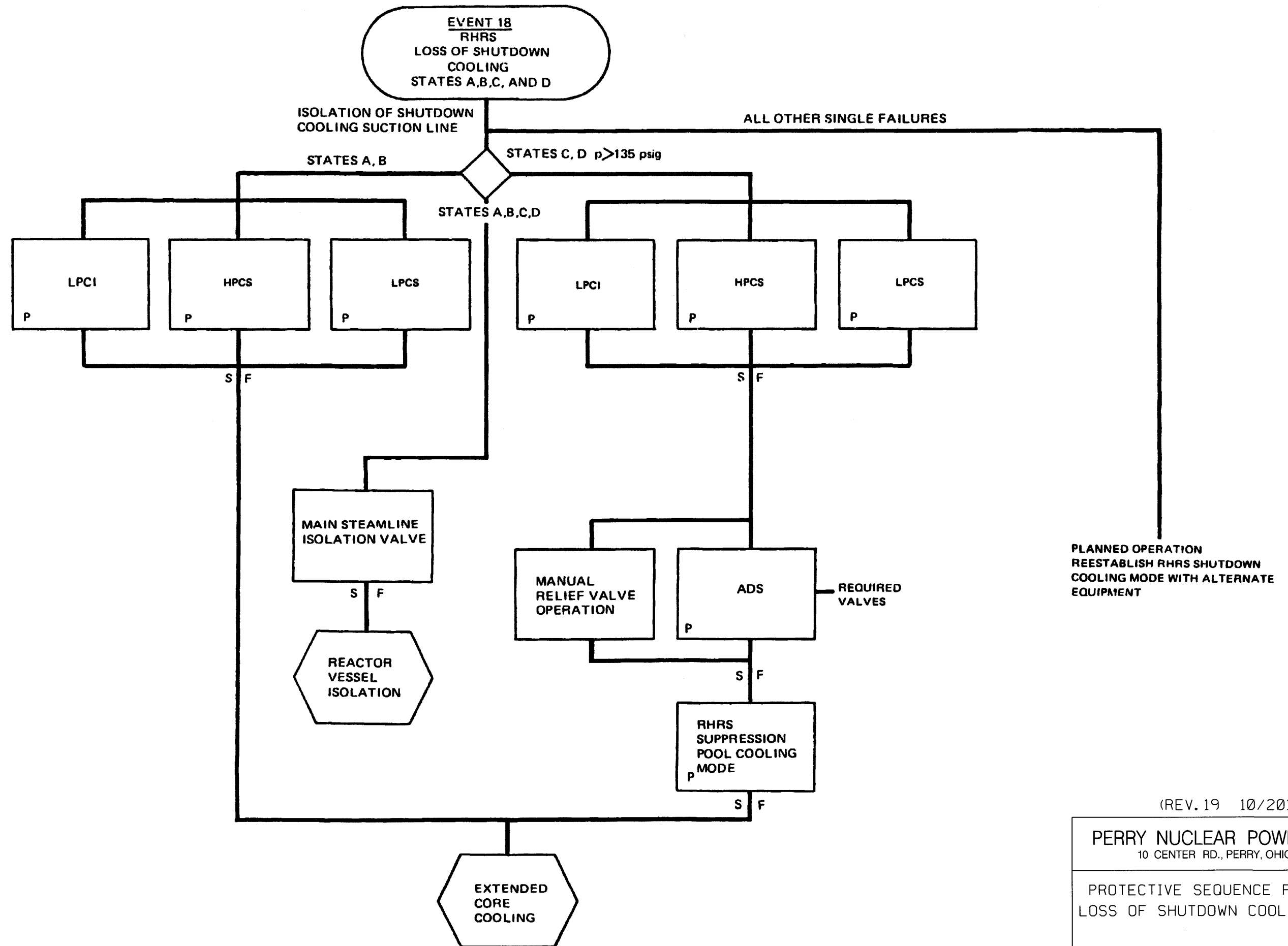

(REV. 19 10/2015)

PERRY NUCLEAR POWER PLANT
10 CENTER RD., PERRY, OHIO 44081

PROTECTIVE SEQUENCE FOR RHRS -
LOSS OF SHUTDOWN COOLING FAILURE

FIGURE 15A.6-18

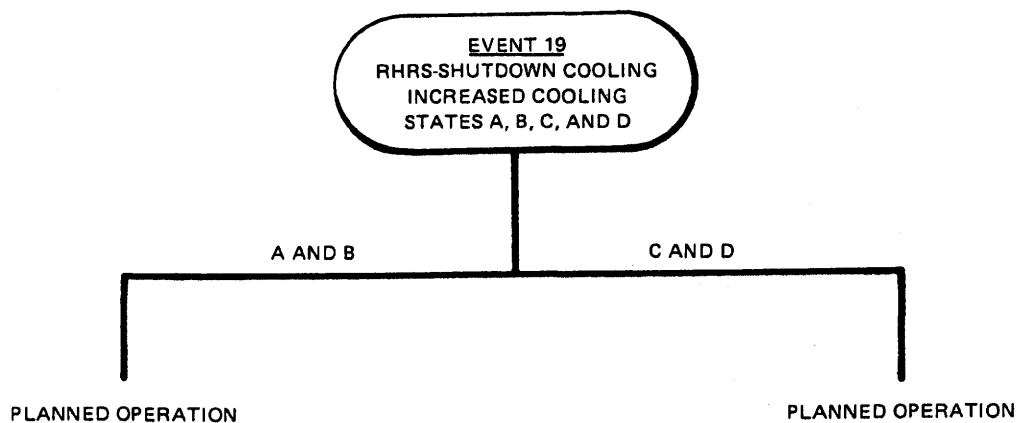

(Rev. 12 1/03)

	PERRY NUCLEAR POWER PLANT
RHRS - Shutdown Cooling Failure - Increased Cooling	
Figure 15A.6-19	

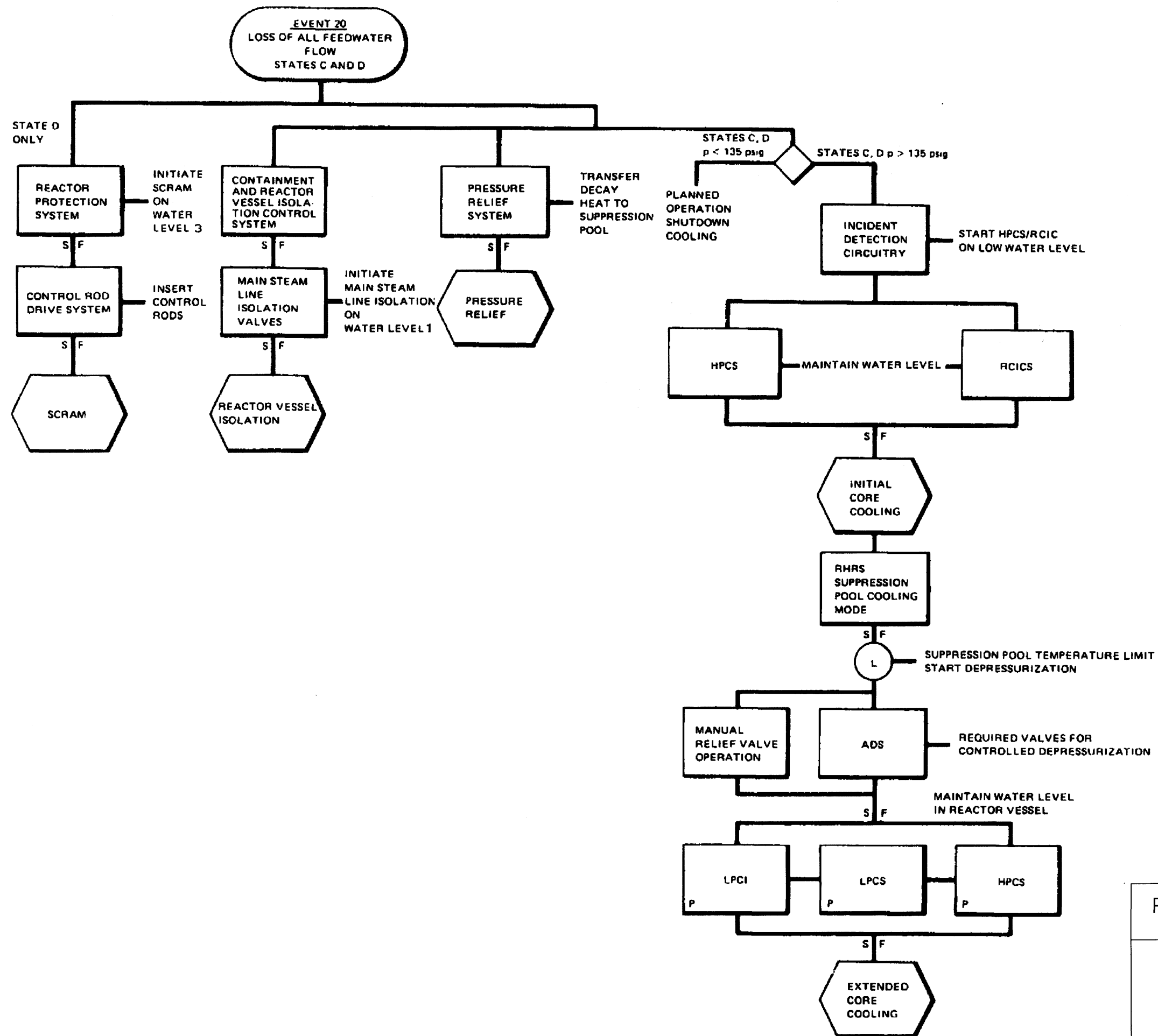

(REV. 19 10/2015)

PERRY NUCLEAR POWER PLANT
10 CENTER RD., PERRY, OHIO 44081

PROTECTIVE SEQUENCE FOR
LOSS OF FEEDWATER FLOW

FIGURE 15A.6-20

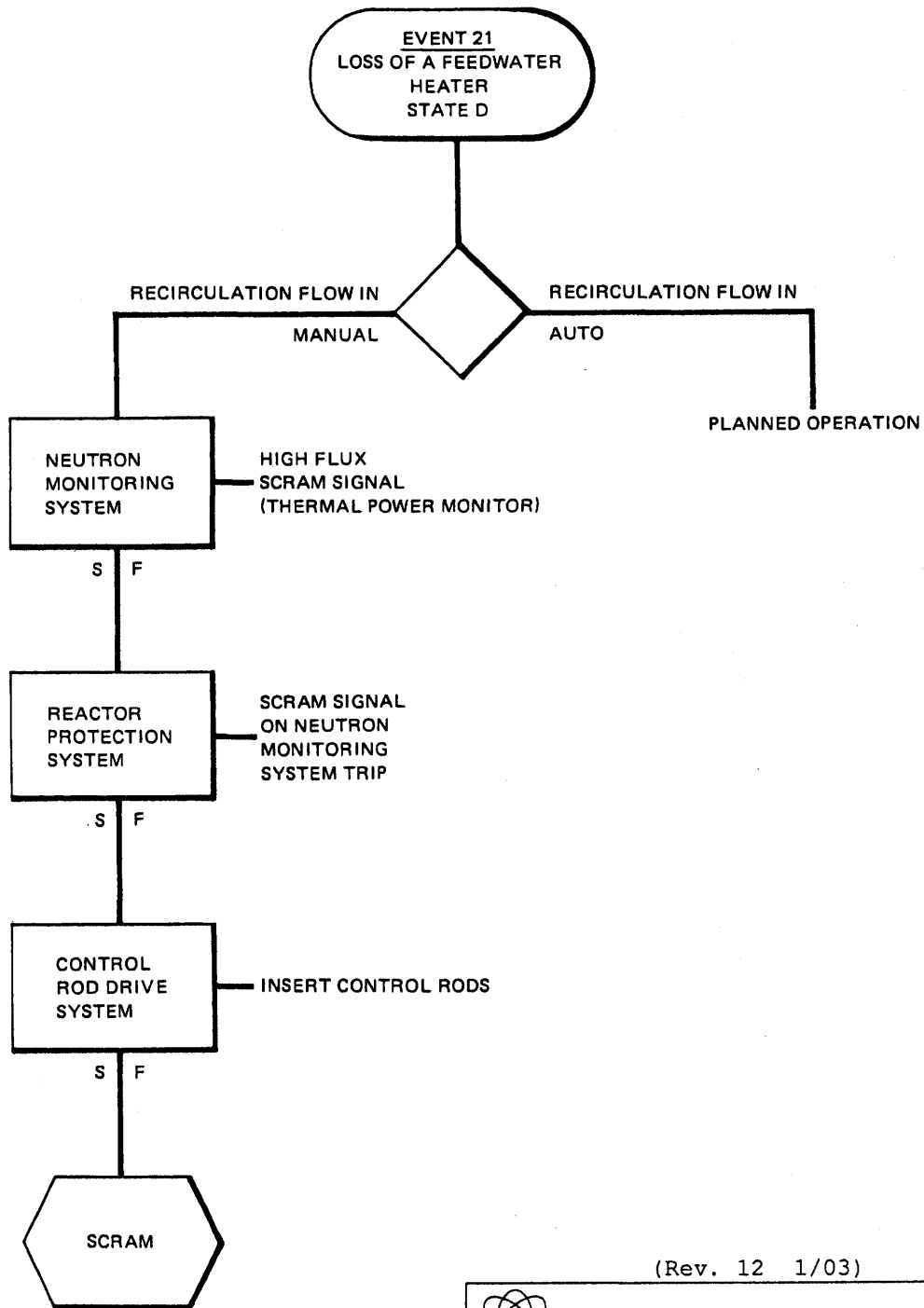

(Rev. 12 1/03)



PERRY NUCLEAR POWER PLANT

Protective Sequence for Loss of a
Feedwater Heater

Figure 15A.6-21

EVENT 22
 FEEDWATER
 CONTROLLER FAILURE
 -MAXIMUM DEMAND
 STATES A, B, C, AND D

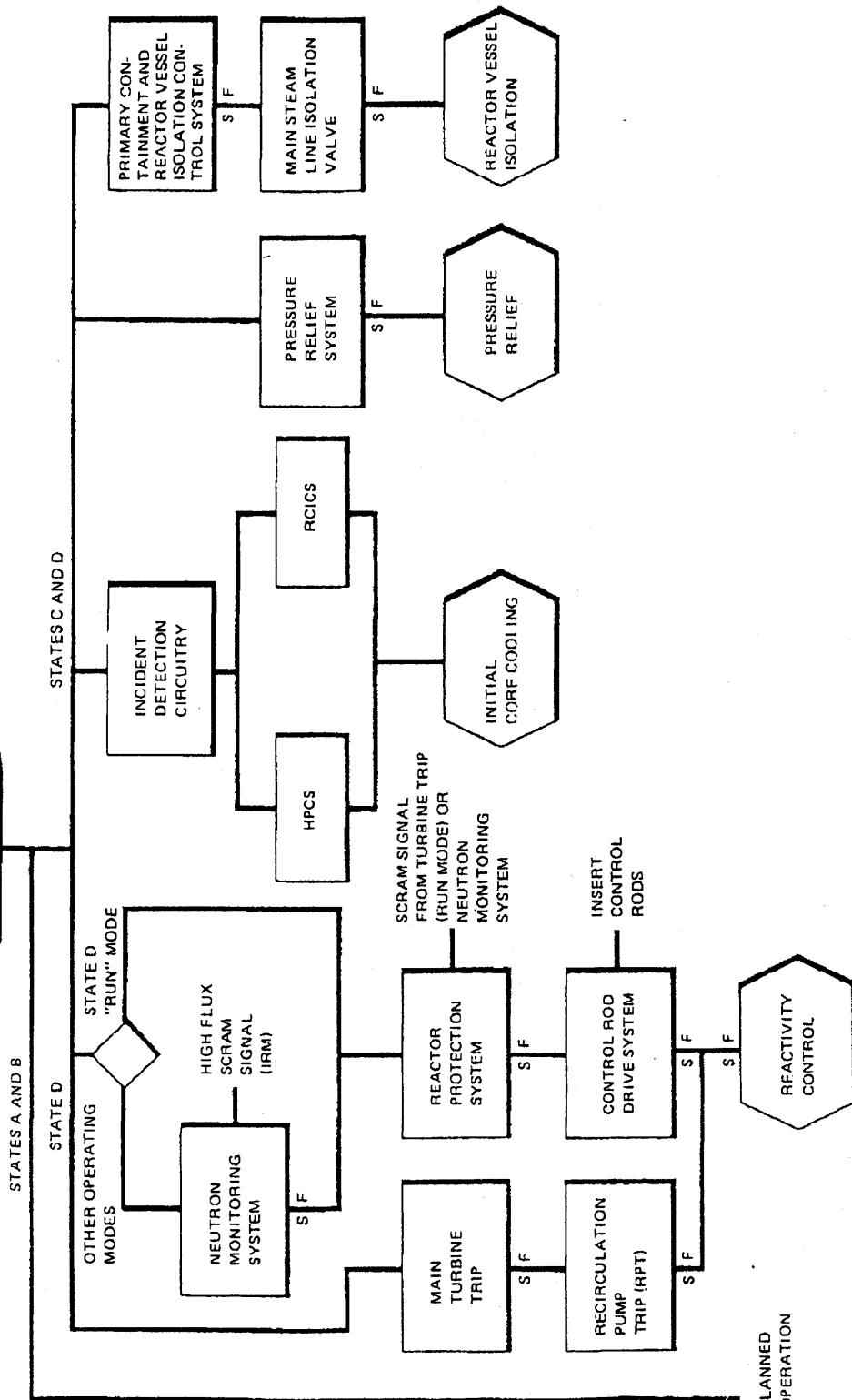

(Rev. 12 1/03)

 **PERRY NUCLEAR POWER PLANT**

Protective Sequences for
 Feedwater Controller Failure -
 Maximum Demand

Figure 15A.6-22

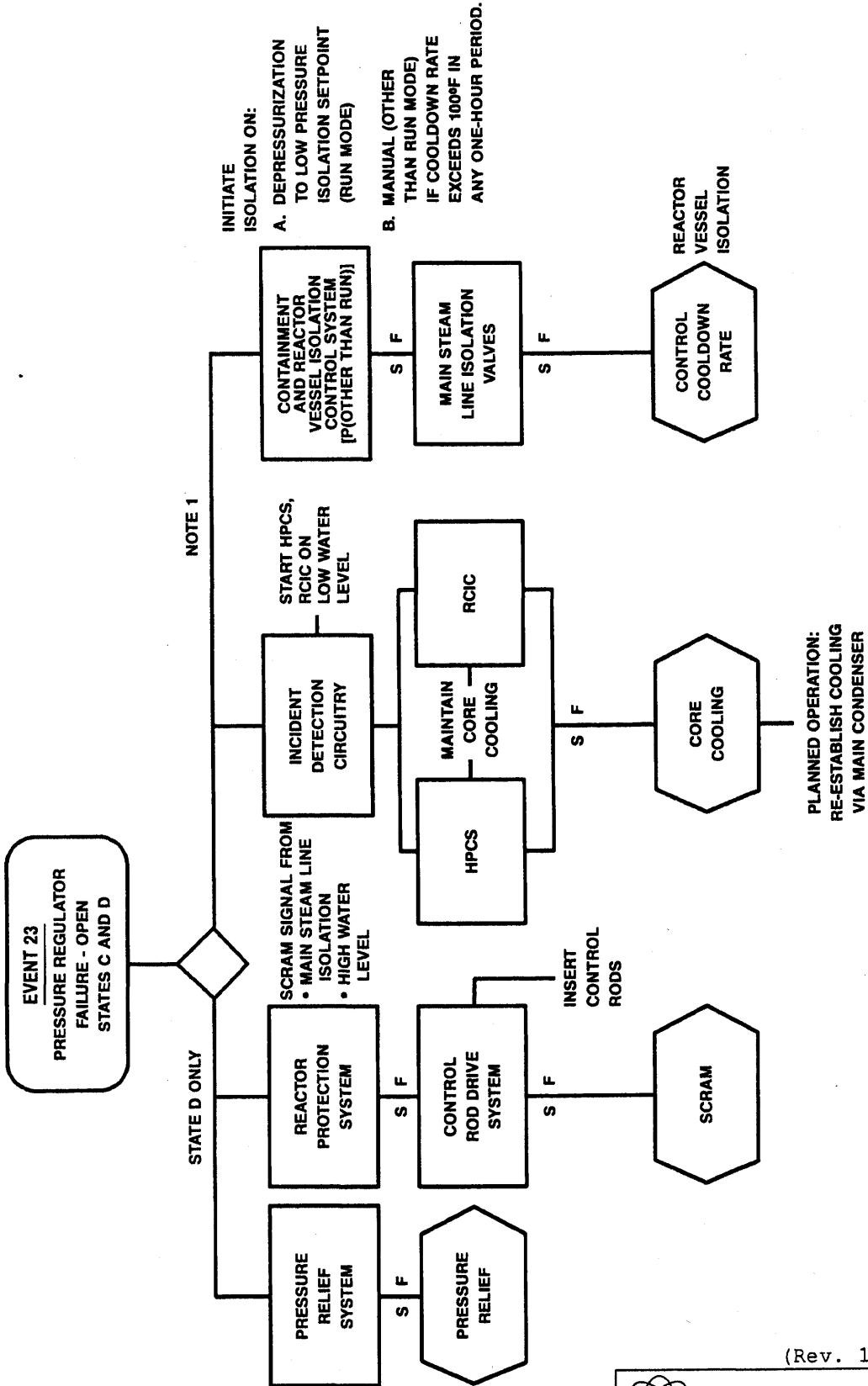

NOTE:

1. THIS PATH IS RELATED ONLY TO CONTROLLING THE COOLDOWN SO AS NOT TO EXCEED THE RATE OF 100°F IN ANY ONE-HOUR PERIOD.

(Rev. 12 1/03)

PERRY NUCLEAR POWER PLANT

Protective Sequences for
Pressure Regulator Failure - Open

Figure 15A.6-23

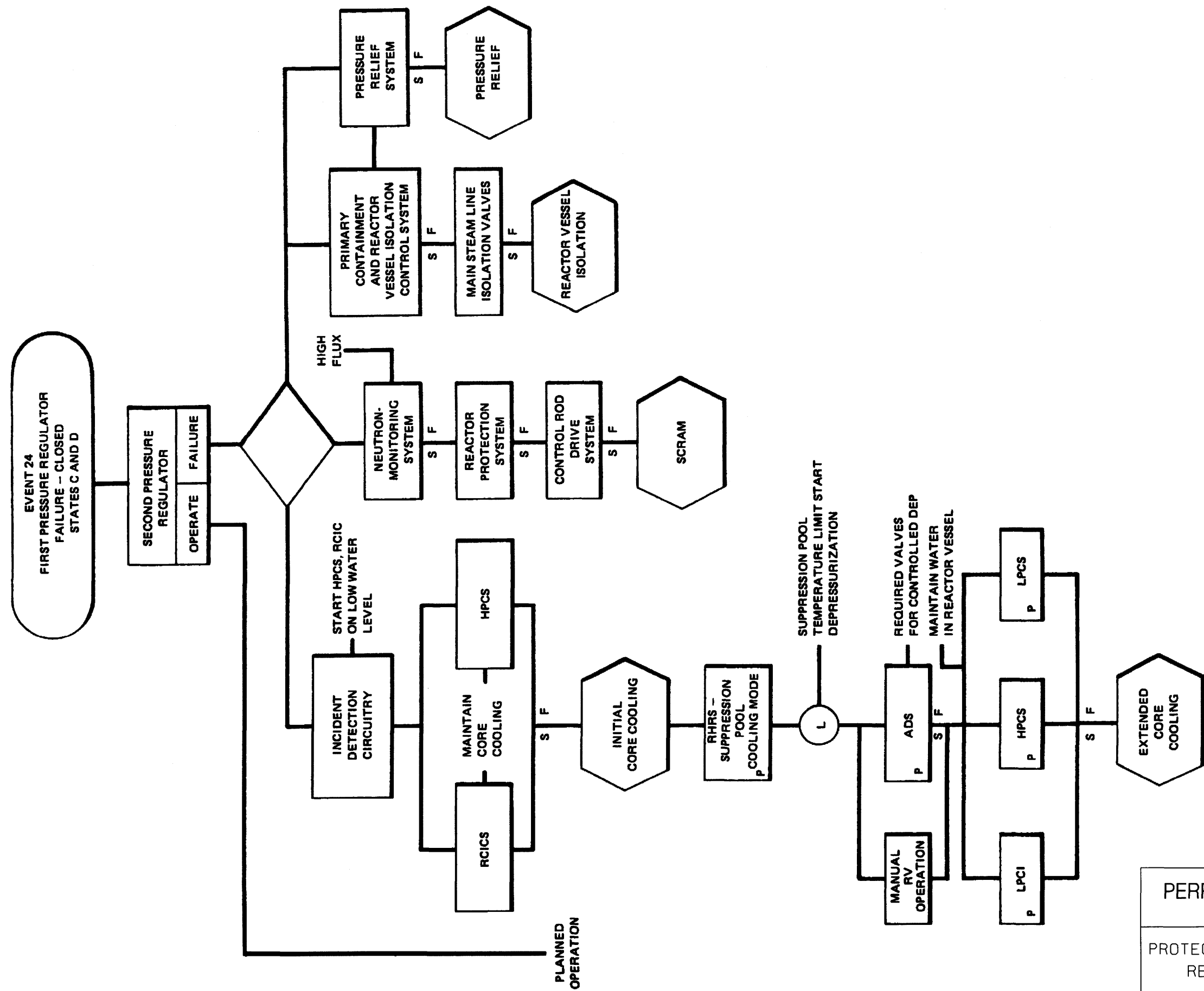

(REV. 19 10/2015)

PERRY NUCLEAR POWER PLANT
 10 CENTER RD., PERRY, OHIO 44081

PROTECTIVE SEQUENCES FOR PRESSURE
 REGULATOR FAILURE - CLOSED

FIGURE 15A.6-24

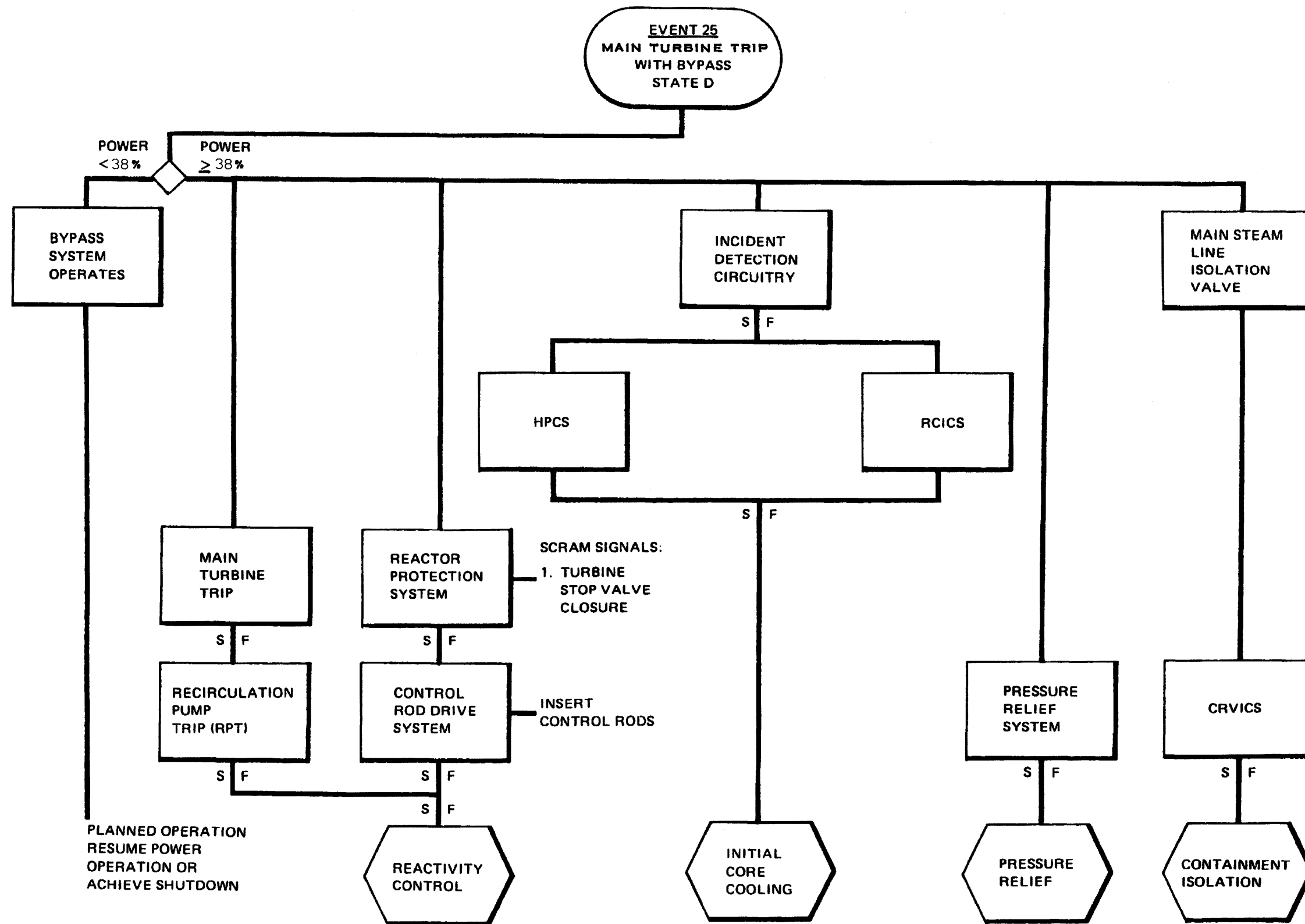

(REV. 19 10/2015)

PERRY NUCLEAR POWER PLANT
10 CENTER RD., PERRY, OHIO 44081

PROTECTIVE SEQUENCES FOR MAIN
TURBINE TRIP WITH BYPASS

FIGURE 15A.6-25

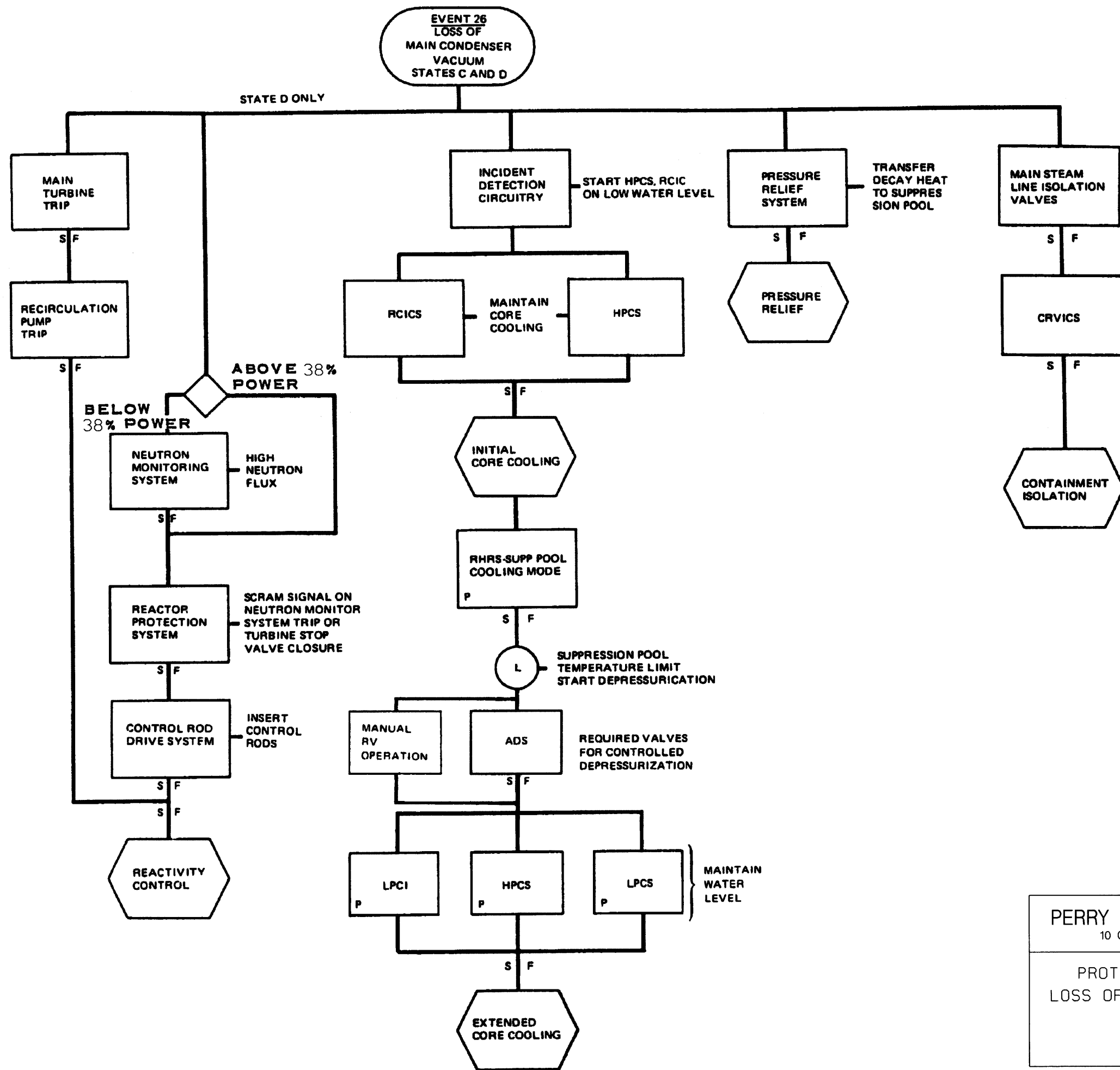

(REV. 19 10/2015)

PERRY NUCLEAR POWER PLANT
10 CENTER RD., PERRY, OHIO 44081

PROTECTIVE SEQUENCES FOR
LOSS OF MAIN CONDENSER VACUUM

FIGURE 15A.6-26

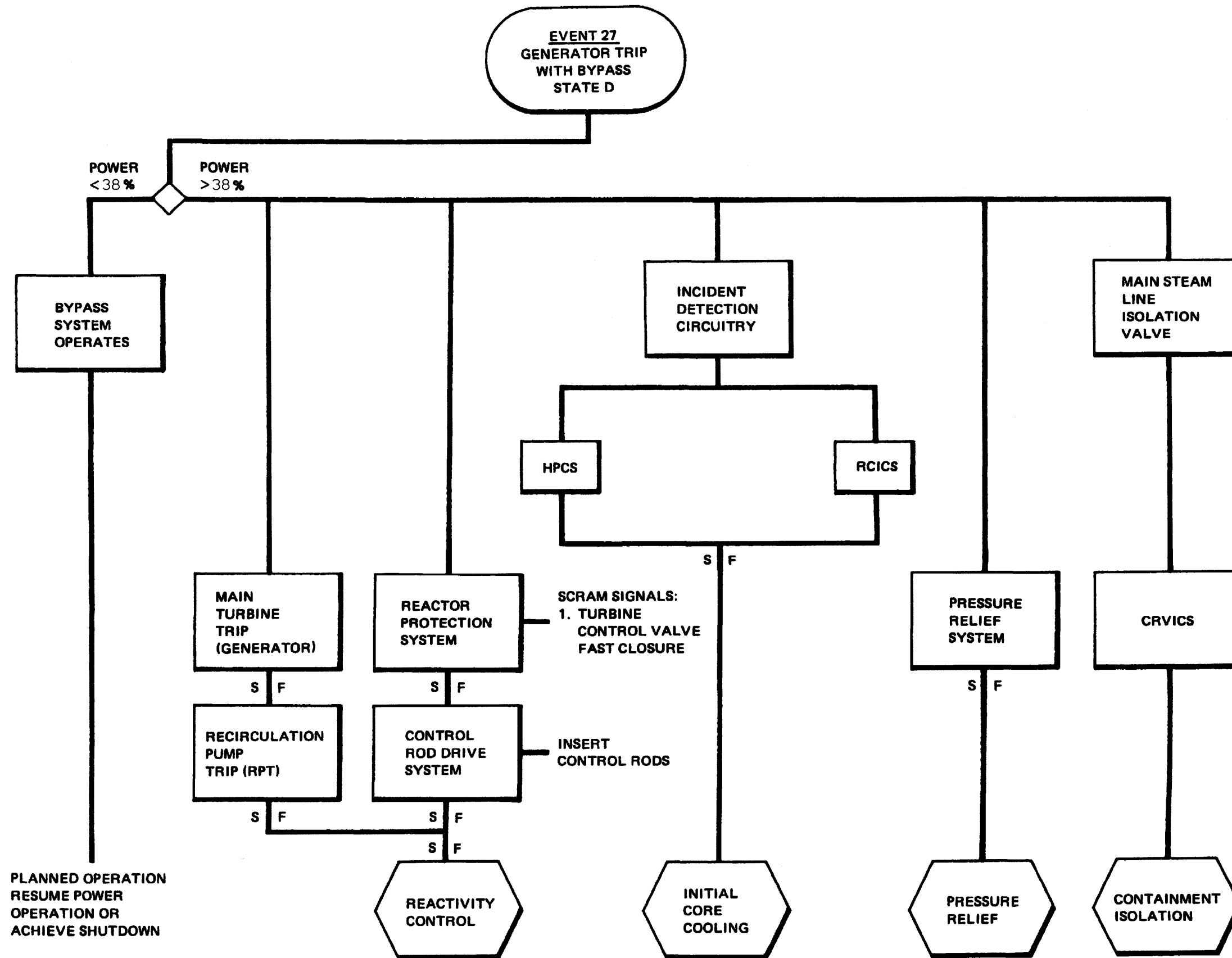

(REV. 19 10/2015)

PERRY NUCLEAR POWER PLANT
 10 CENTER RD., PERRY, OHIO 44081

PROTECTIVE SEQUENCES FOR MAIN
 GENERATOR TRIP WITH BYPASS

FIGURE 15A.6-27

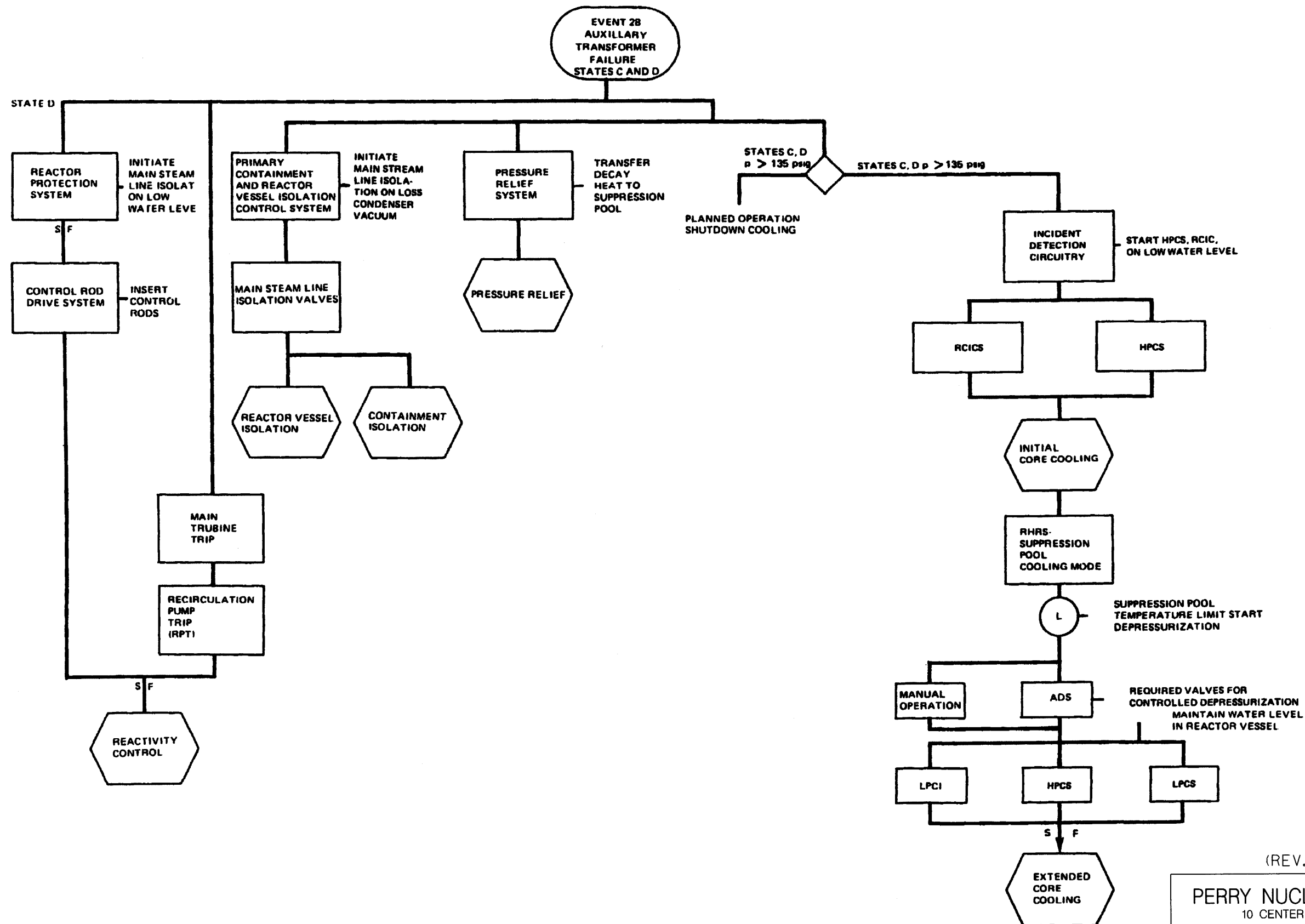

(REV. 19 10/2015)

PERRY NUCLEAR POWER PLANT
10 CENTER RD., PERRY, OHIO 44081

PROTECTIVE SEQUENCE FOR
AUXILIARY TRANSFORMER FAILURE

FIGURE 15A.6-28

**EVENT 29
LOSS OF OFFSITE
AC POWER-GRID
CONNECTOR LOSS
STATES
A, B, C AND D**

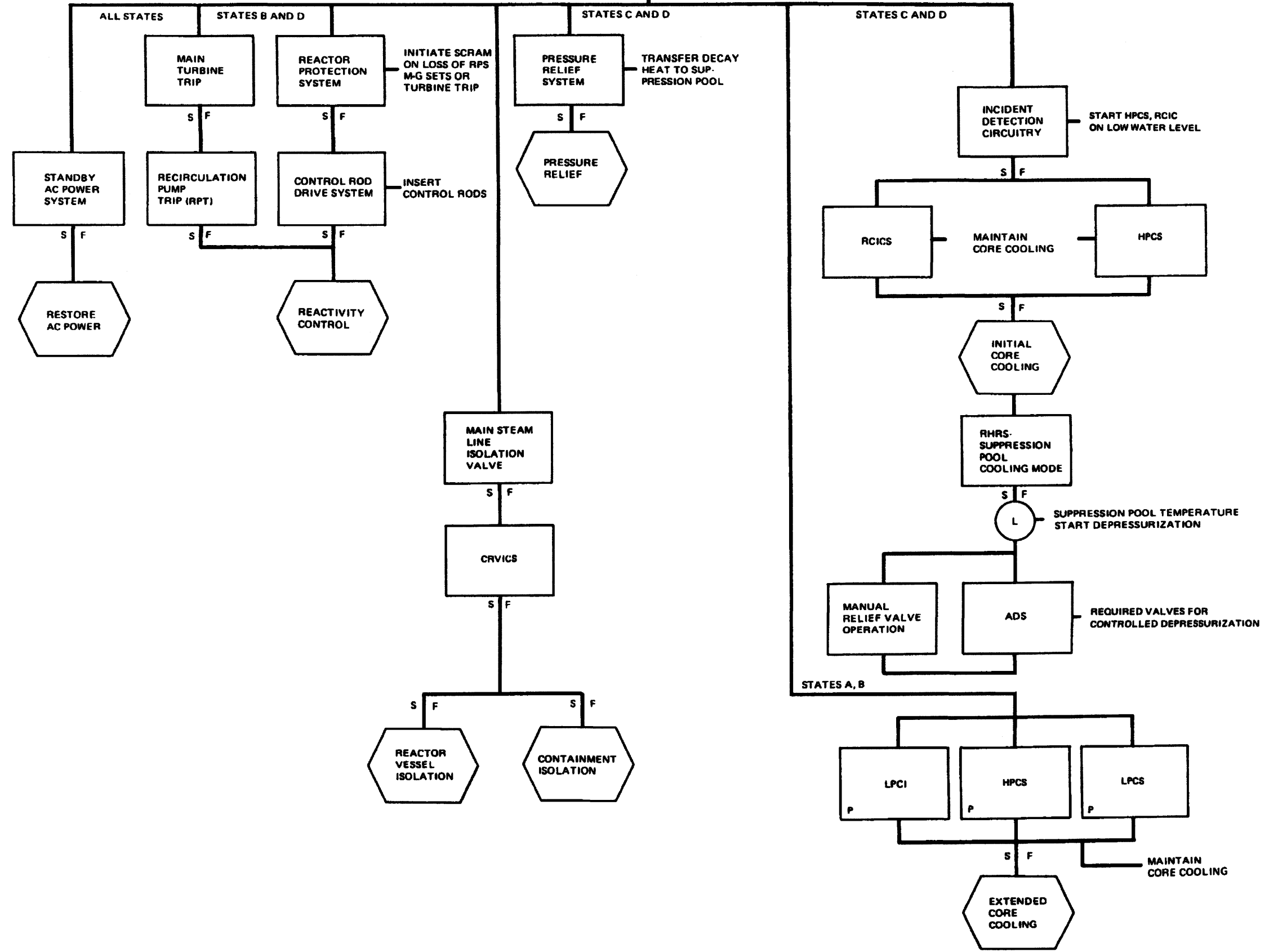

(REV. 19 10/2015)

PERRY NUCLEAR POWER PLANT
10 CENTER RD., PERRY, OHIO 44081

PROTECTIVE SEQUENCES FOR LOSS OF
AC POWER - GRID CONNECTION LOSS

FIGURE 15A.6-29

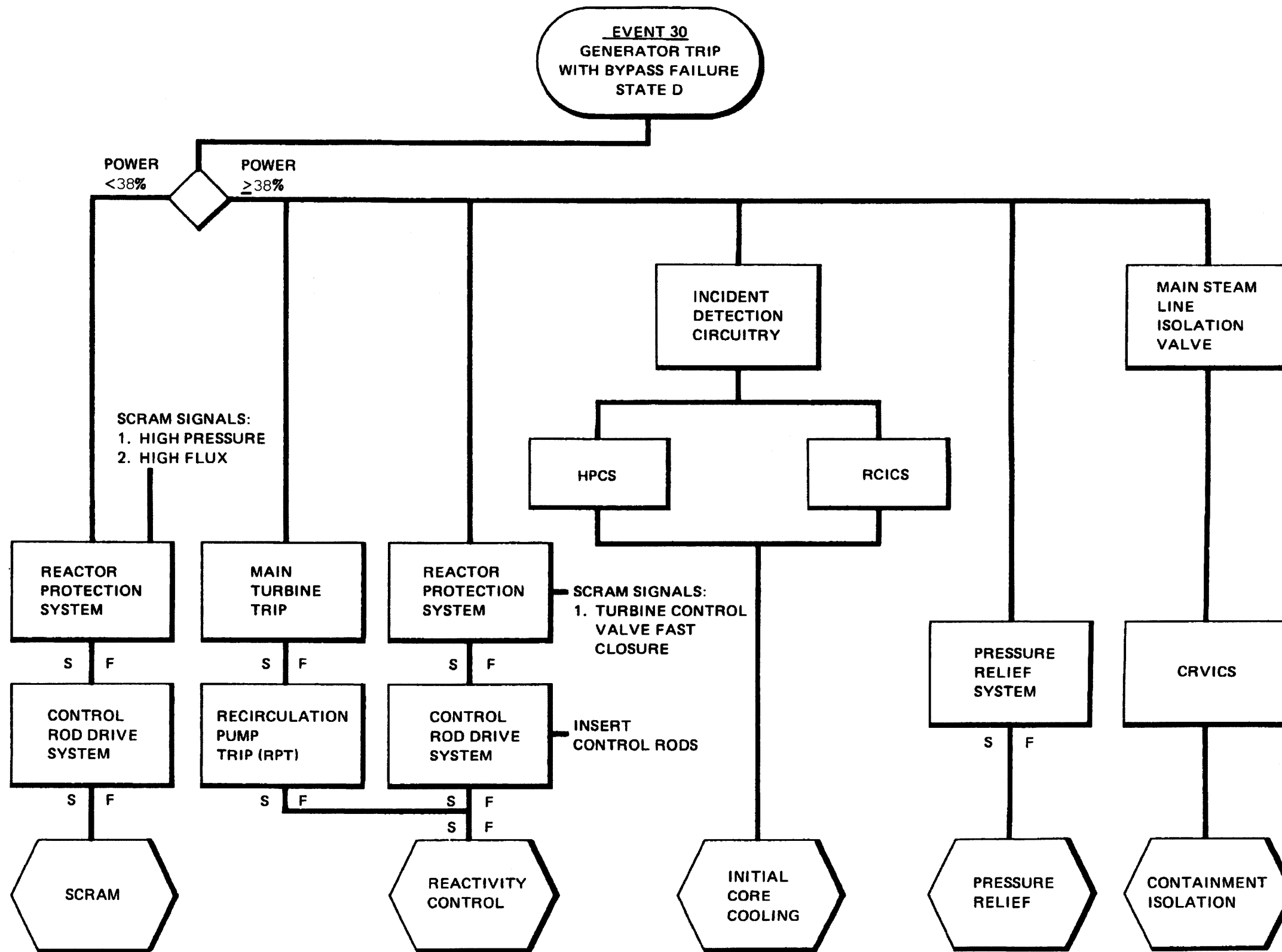

(REV. 19 10/2015)

PERRY NUCLEAR POWER PLANT
10 CENTER RD., PERRY, OHIO 44081

PROACTIVE SEQUENCES FOR MAIN
GENERATOR TRIP - WITH BYPASS FAILURE

FIGURE 15A.6-30

**EVENT 31
MAIN TURBINE TRIP
WITH BYPASS FAILURE
STATE D**

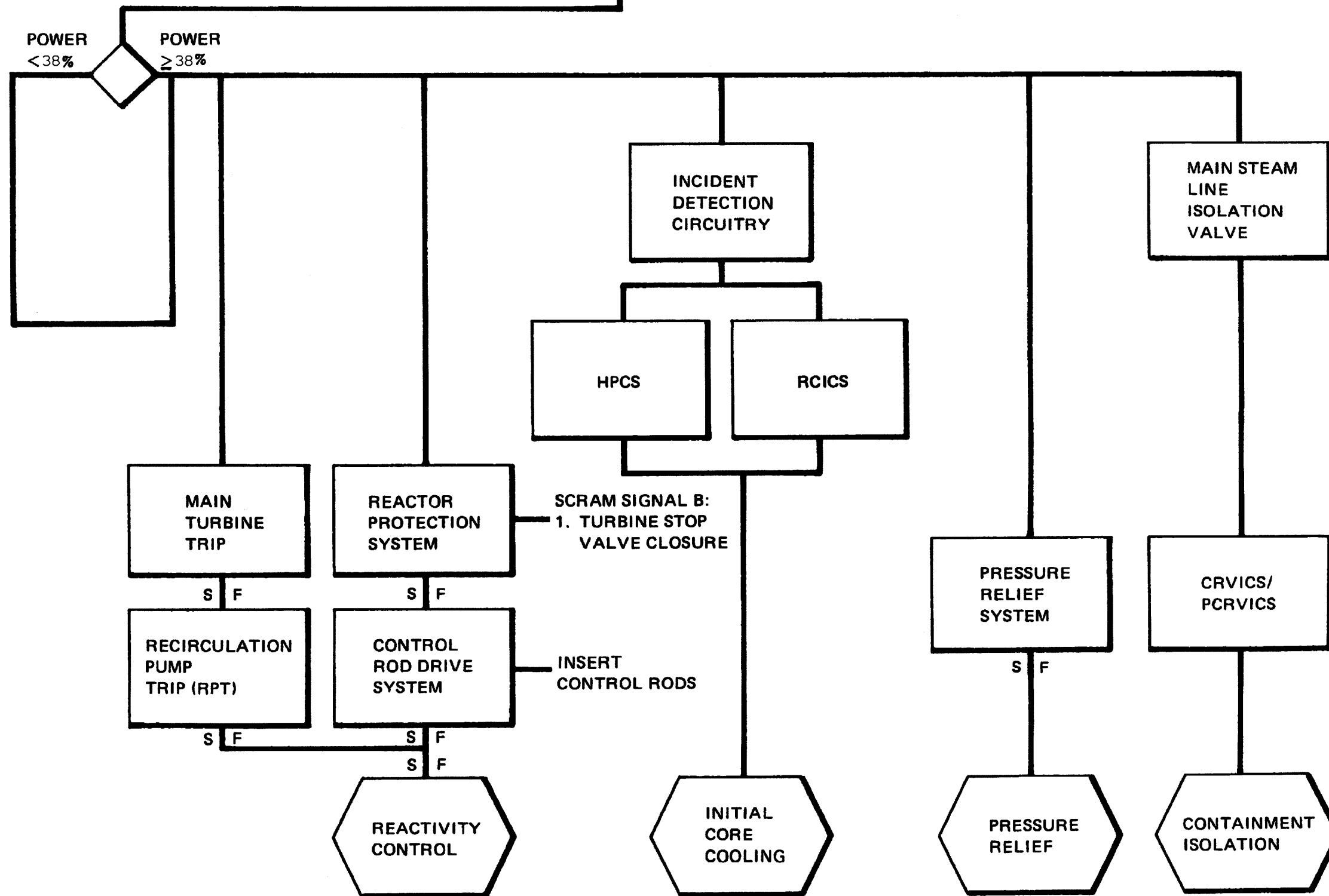

(REV. 19 10/2015)

PERRY NUCLEAR POWER PLANT
10 CENTER RD., PERRY, OHIO 44081

PROTECTIVE SEQUENCES FOR TURBINE TRIP - WITH BYPASS FAILURE

FIGURE 15A.6-31

EVENT 32
INADVERTENT LOADING AND
OPERATION – FUEL ASSEMBLY
IN IMPROPER POSITION
STATES A, B, C, D

PLANNED
OPERATION

(Rev. 12 1/03)



PERRY NUCLEAR POWER PLANT

Protective Sequence for
Inadvertent Loading and Operation
of Fuel Assembly in
Improper Position

Figure 15A.6-32

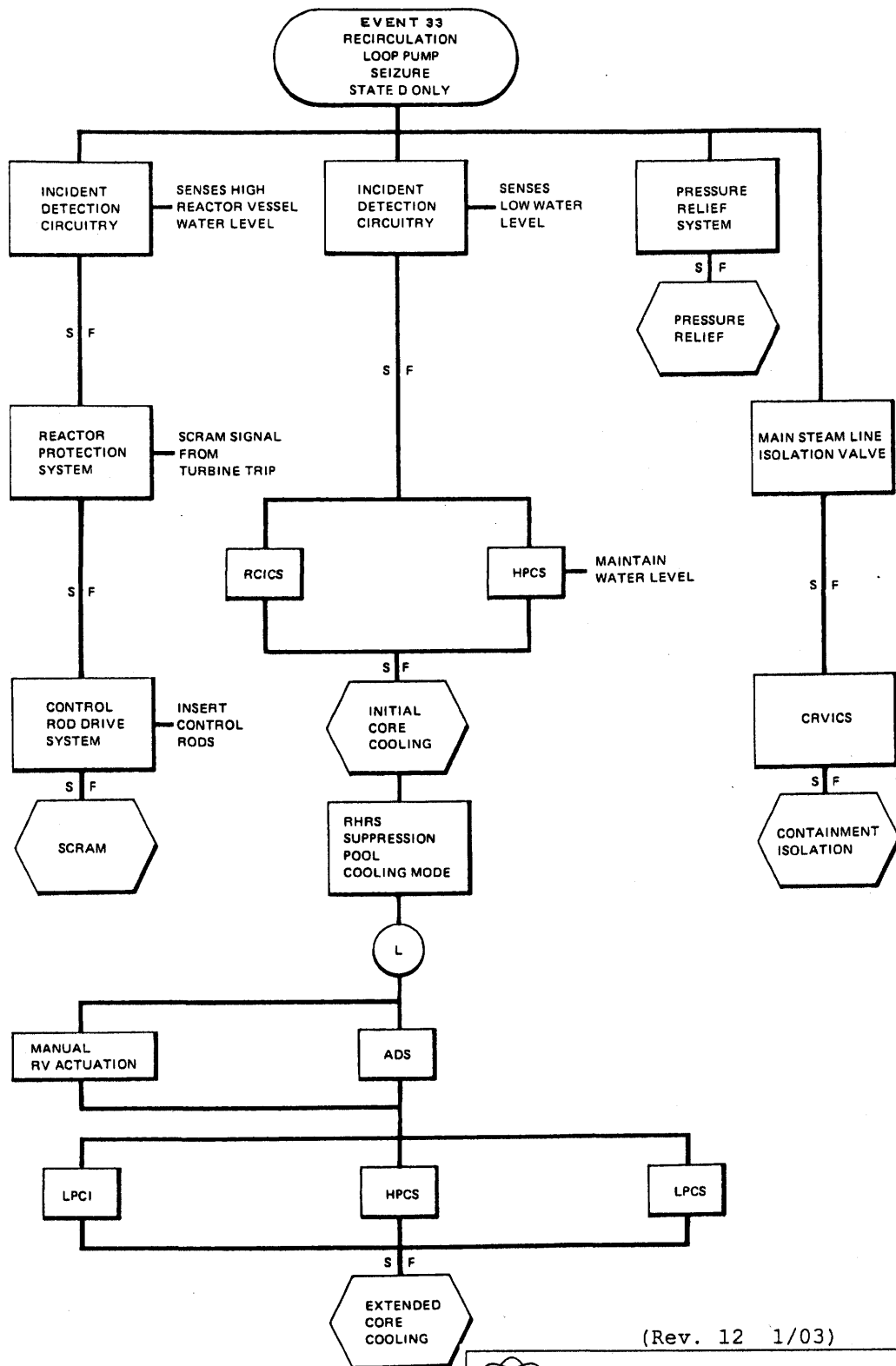

(Rev. 12 1/03)



PERRY NUCLEAR POWER PLANT

Protective Sequence for
Recirculation Loop Pump Seizure

Figure 15A.6-33

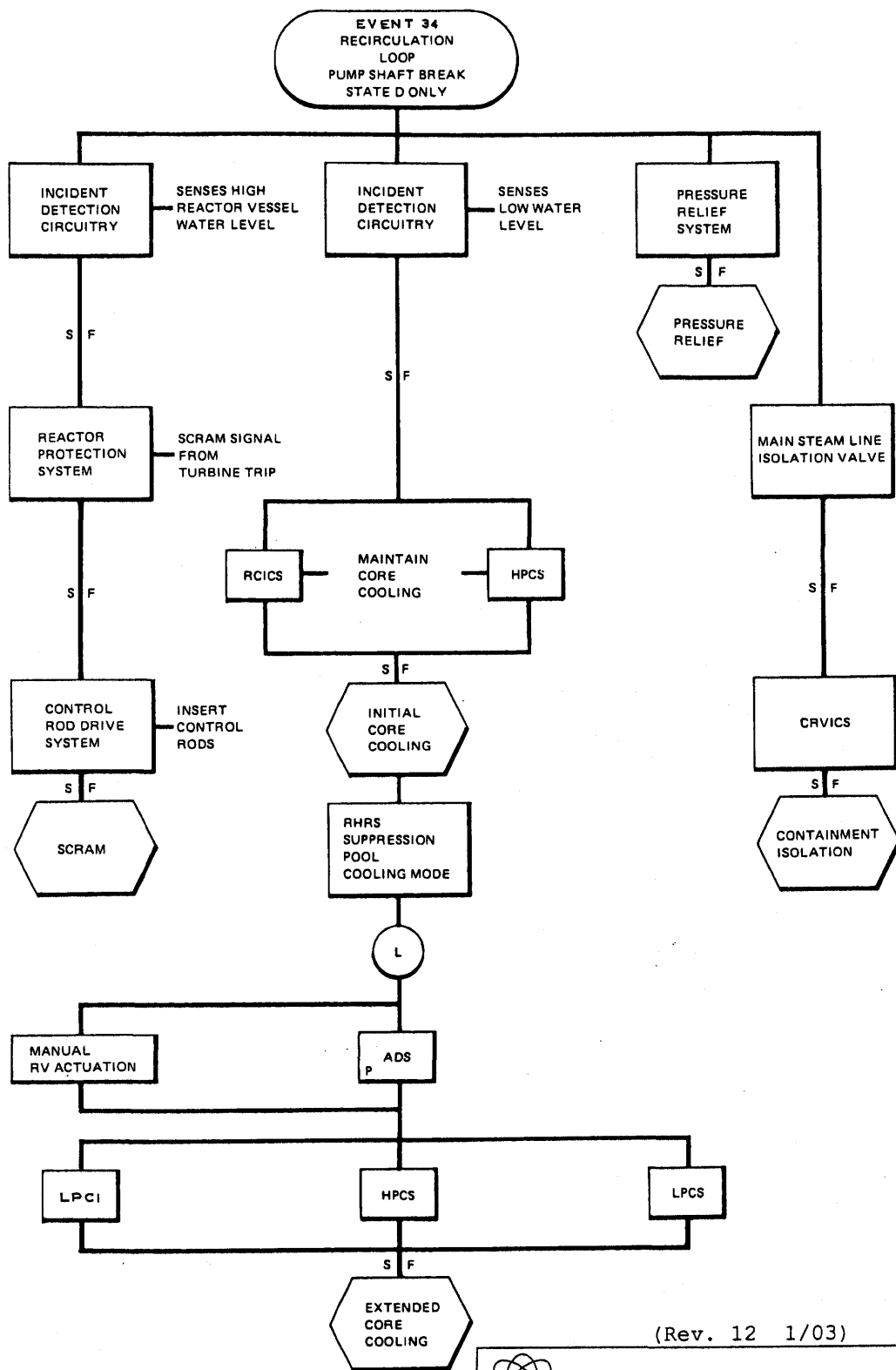

(Rev. 12 1/03)



PERRY NUCLEAR POWER PLANT

Protective Sequence for
Recirculation Loop Pump
Shaft Break

Figure 15A.6-34

**EVENT 35
CONTROL ROD
DROP ACCIDENT
STATE D WITH
MODE SWITCH IN RUN**

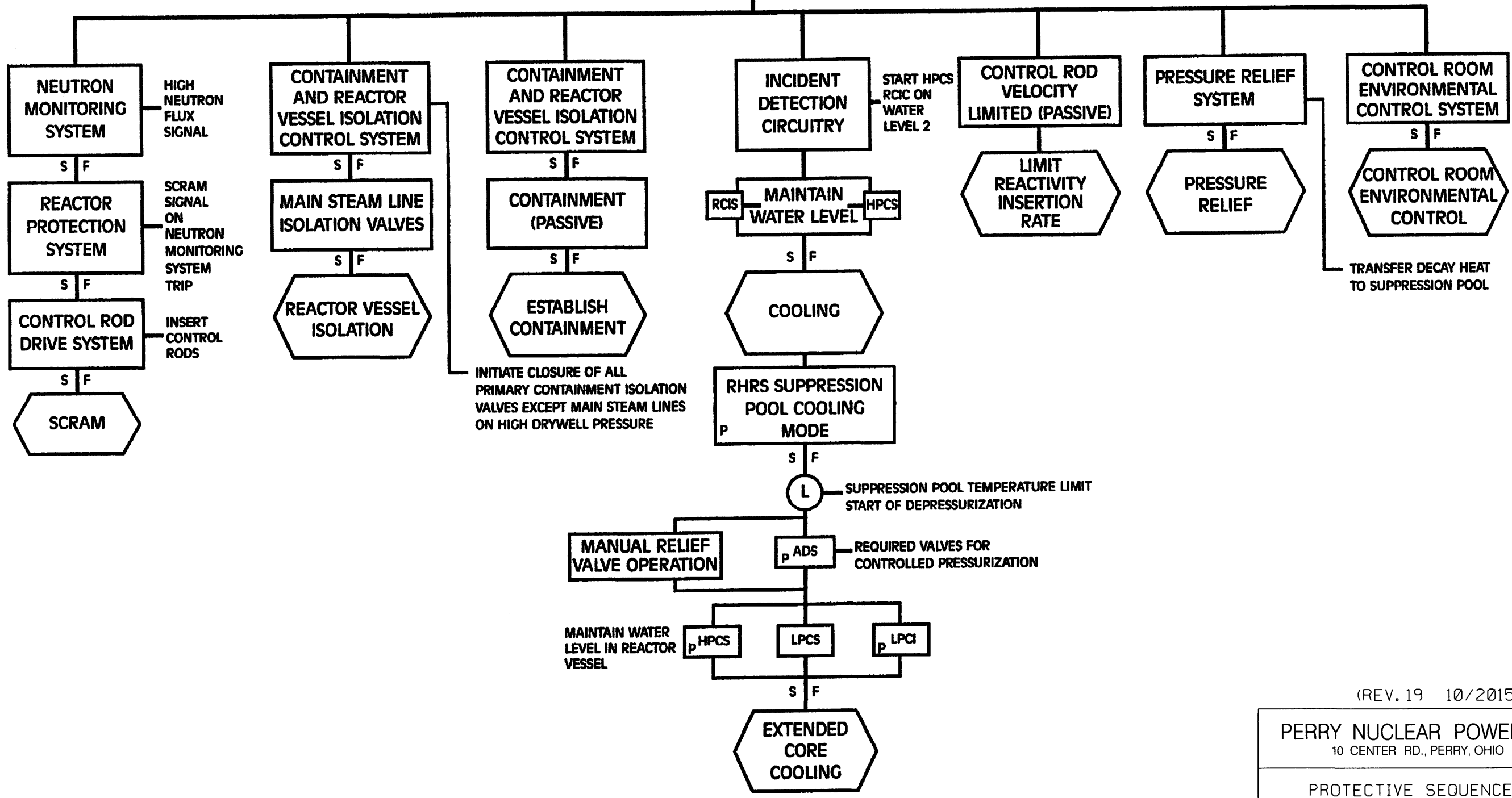

(REV. 19 10/2015)

PERRY NUCLEAR POWER PLANT
10 CENTER RD., PERRY, OHIO 44081

PROTECTIVE SEQUENCES FOR
CONTROL ROD DROP ACCIDENT

FIGURE 15A.6-35

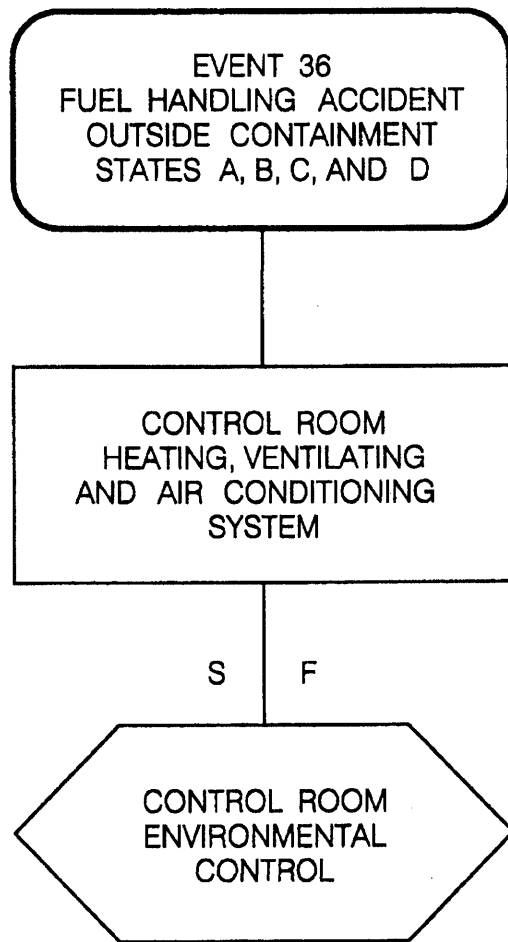

(Rev. 13 12/03)



PERRY NUCLEAR POWER PLANT

Protective Sequences for Fuel
Handling Accident
Outside Containment

Figure 15A.6-36

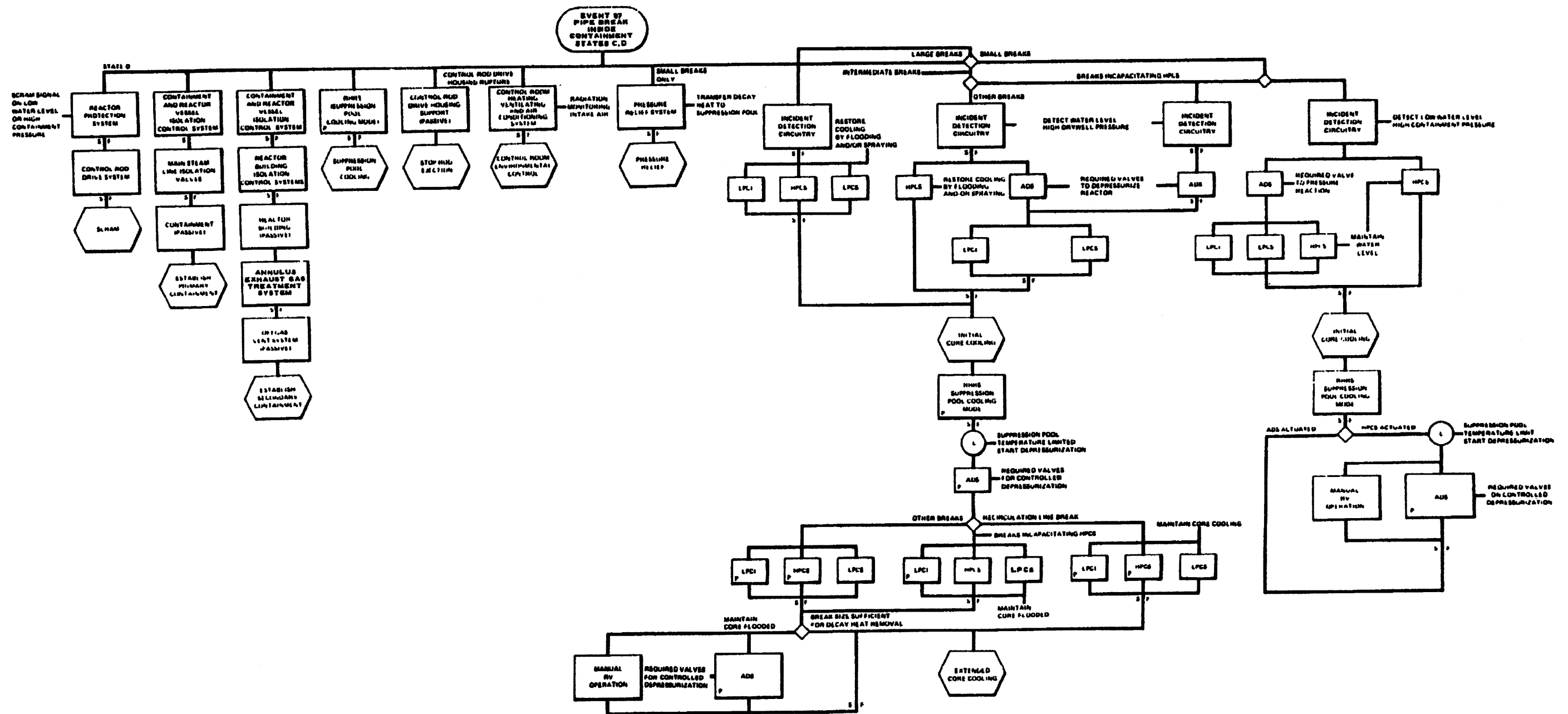

(REV. 19 10/2015)

PERRY NUCLEAR POWER PLANT
10 CENTER RD., PERRY, OHIO 44081

PROTECTIVE SEQUENCES FOR
LOSS-OF-COOLANT PIPING BREAKS
IN RCPS - INSIDE CONTAINMENT

FIGURE 15A.6-37

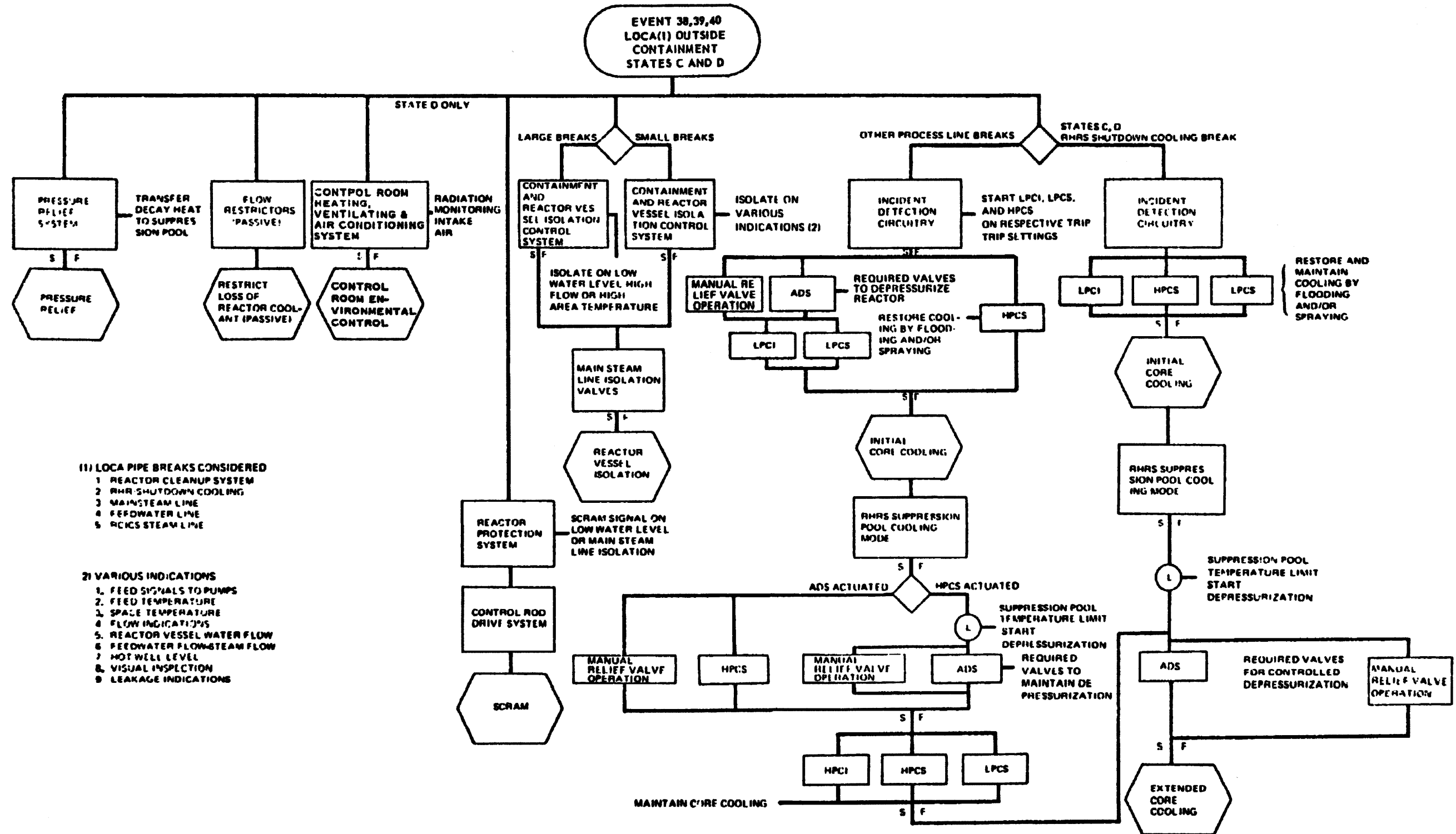

(REV. 19 10/2015)

PERRY NUCLEAR POWER PLANT
10 CENTER RD., PERRY, OHIO 44081

PROTECTIVE SEQUENCES FOR LIQUID,
STEAM, LARGE, SMALL PIPING
BREAKS OUTSIDE CONTAINMENT

FIGURE 15A.6-38

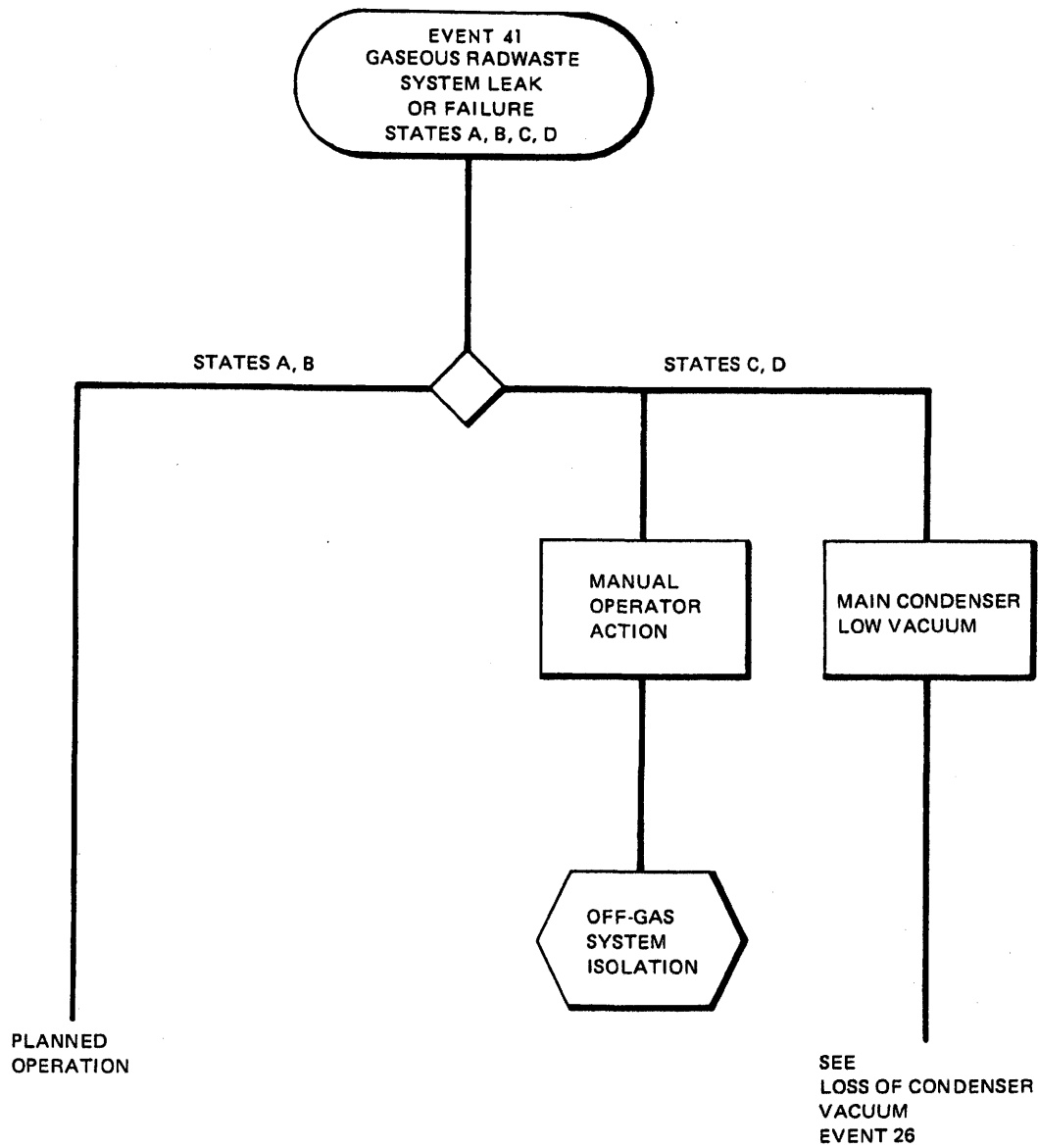

(Rev. 12 1/03)

	PERRY NUCLEAR POWER PLANT
Protective Sequences for Gaseous Radwaste System Leak or Failure	
Figure 15A.6-39	

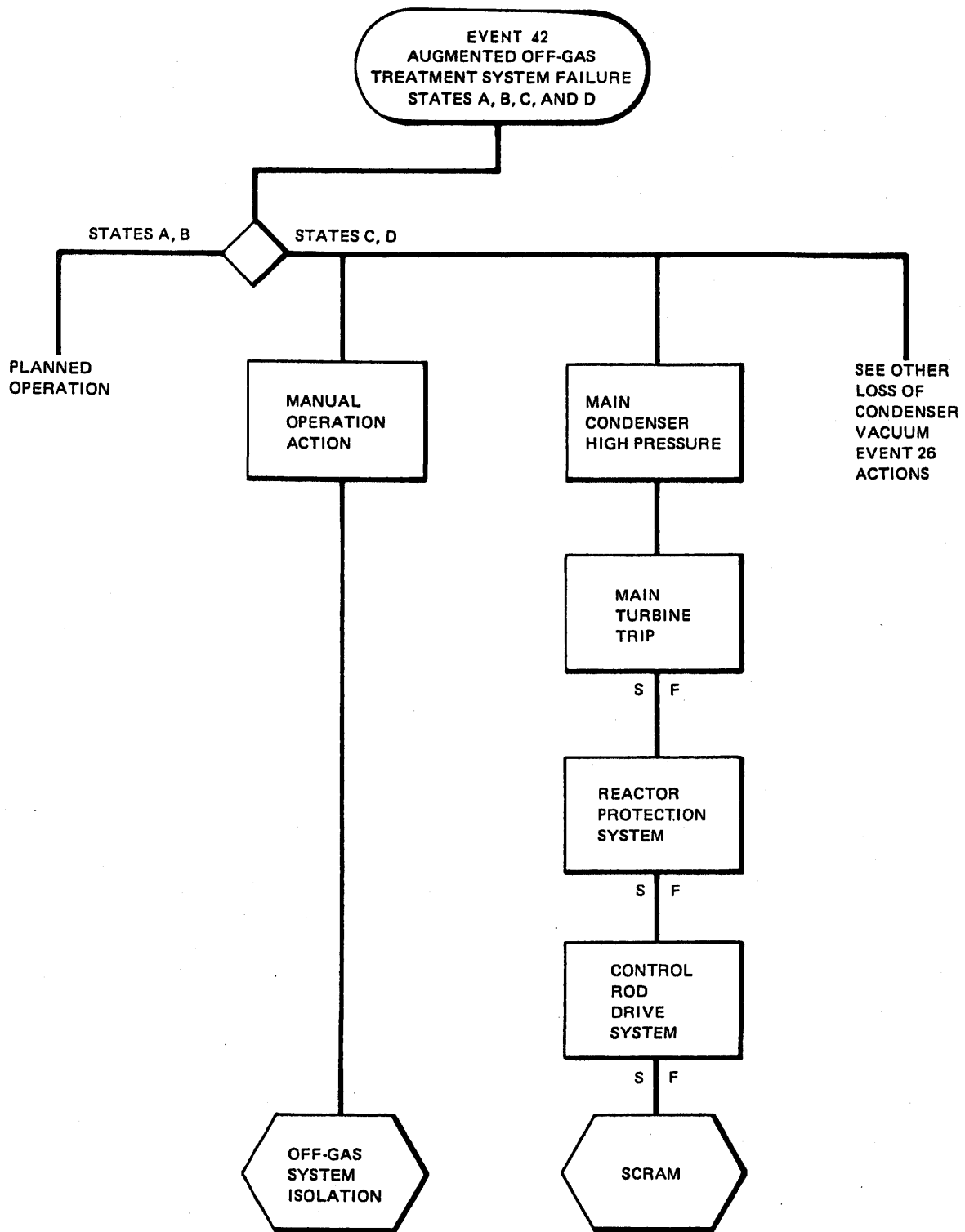

(Rev. 12 1/03)

	PERRY NUCLEAR POWER PLANT
Protective Sequences Augmented Offgas Treatment System Failure	
Figure 15A.6-40	

EVENT 43
RADIOACTIVE LIQUID WASTE
SYSTEM FAILURES
(RELEASE TO ATMOSPHERE)
STATES A, B, C, D

HIGH RADIATION
PROCESS VENTILATION
RADIATION MONITORING
SUBSYSTEM

VENTILATION
SYSTEM
CONTROL

RESTRICT
BUILDING
ACCESS

(Rev. 12 1/03)



PERRY NUCLEAR POWER PLANT

Protective Sequences Augmented
Liquid Radwaste System Failures

Figure 15A.6-41

EVENT 44
POSTULATED RADIOACTIVE
LIQUID RELEASES DUE TO
LIQUID-CONTAINING TANK FAIL-
URES STATES A, B, C, D

HIGH WATER
FLOOR DRAIN
MONITORING
SYSTEM

SUMP
PUMP
SYSTEM

CONTAIN
LIQUID
EFFLUENT

(Rev. 12 1/03)



PERRY NUCLEAR POWER PLANT

Protective Sequence for Liquid
Radwaste System Storage Tank
Failures

Figure 15A.6-42

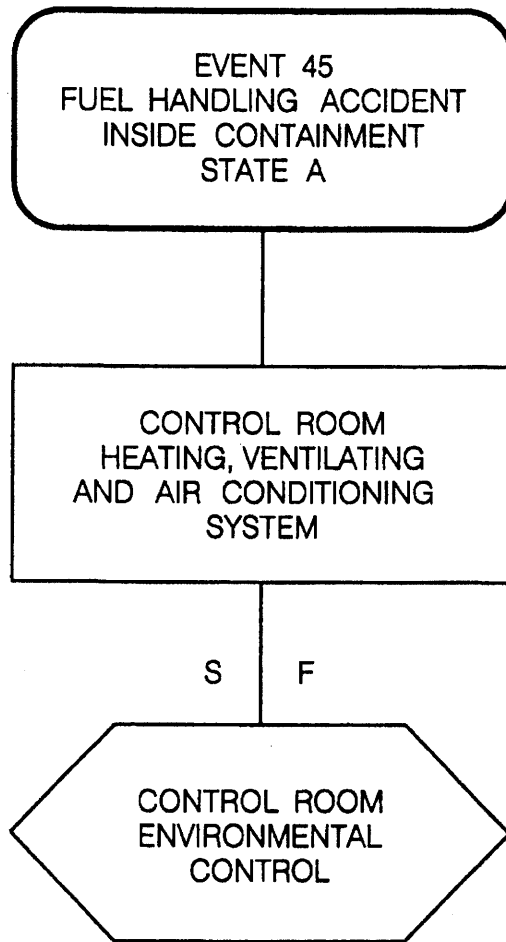

(Rev. 13 12/03)



PERRY NUCLEAR POWER PLANT

Protective Sequences for Fuel
Handling Accident Inside
Containment

Figure 15A.6-43

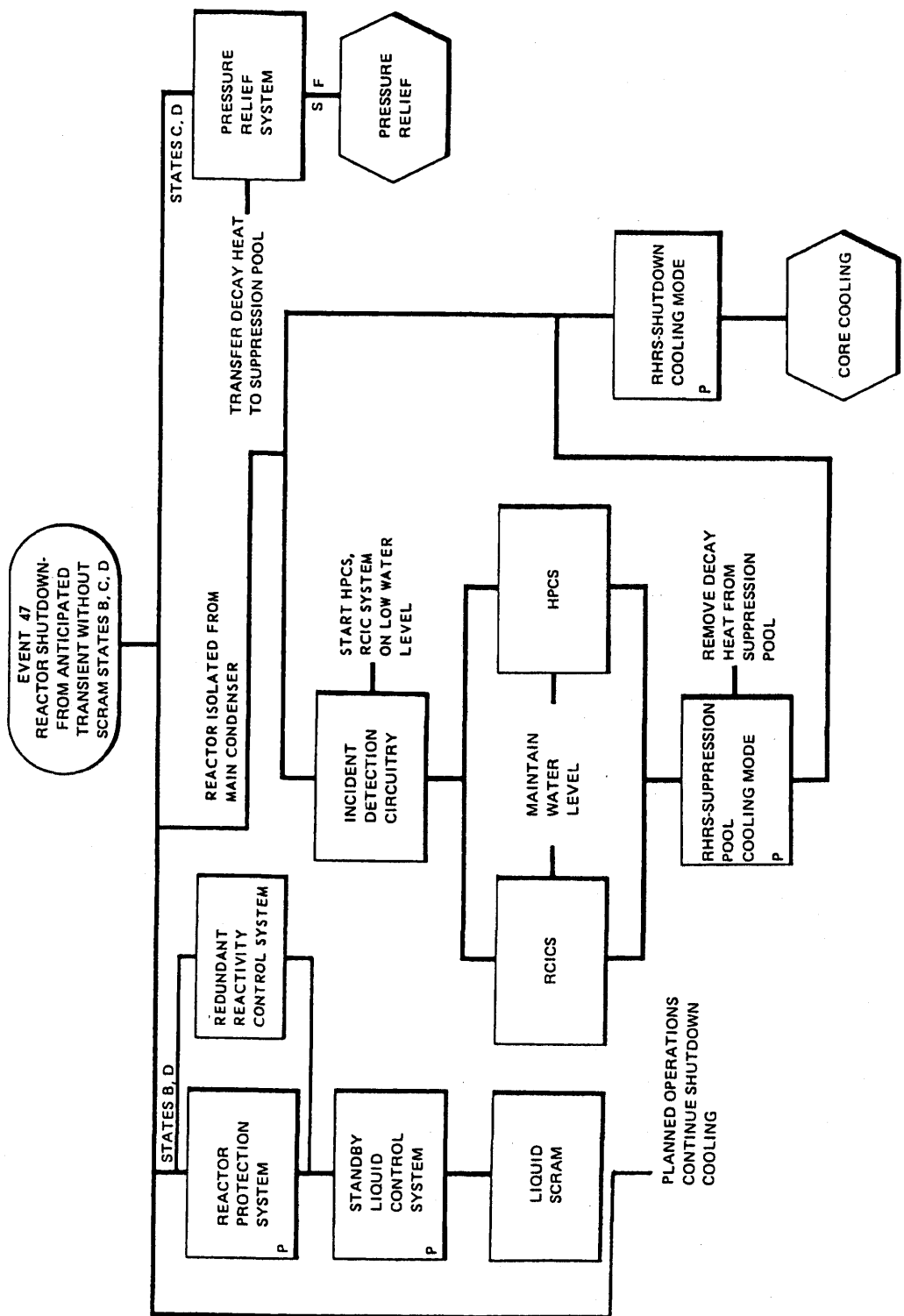

(Rev. 12 1/03)

 PERRY NUCLEAR POWER PLANT
Protective Sequence for Reactor Shutdown From Anticipated Transient Without Scram
Figure 15A.6-44

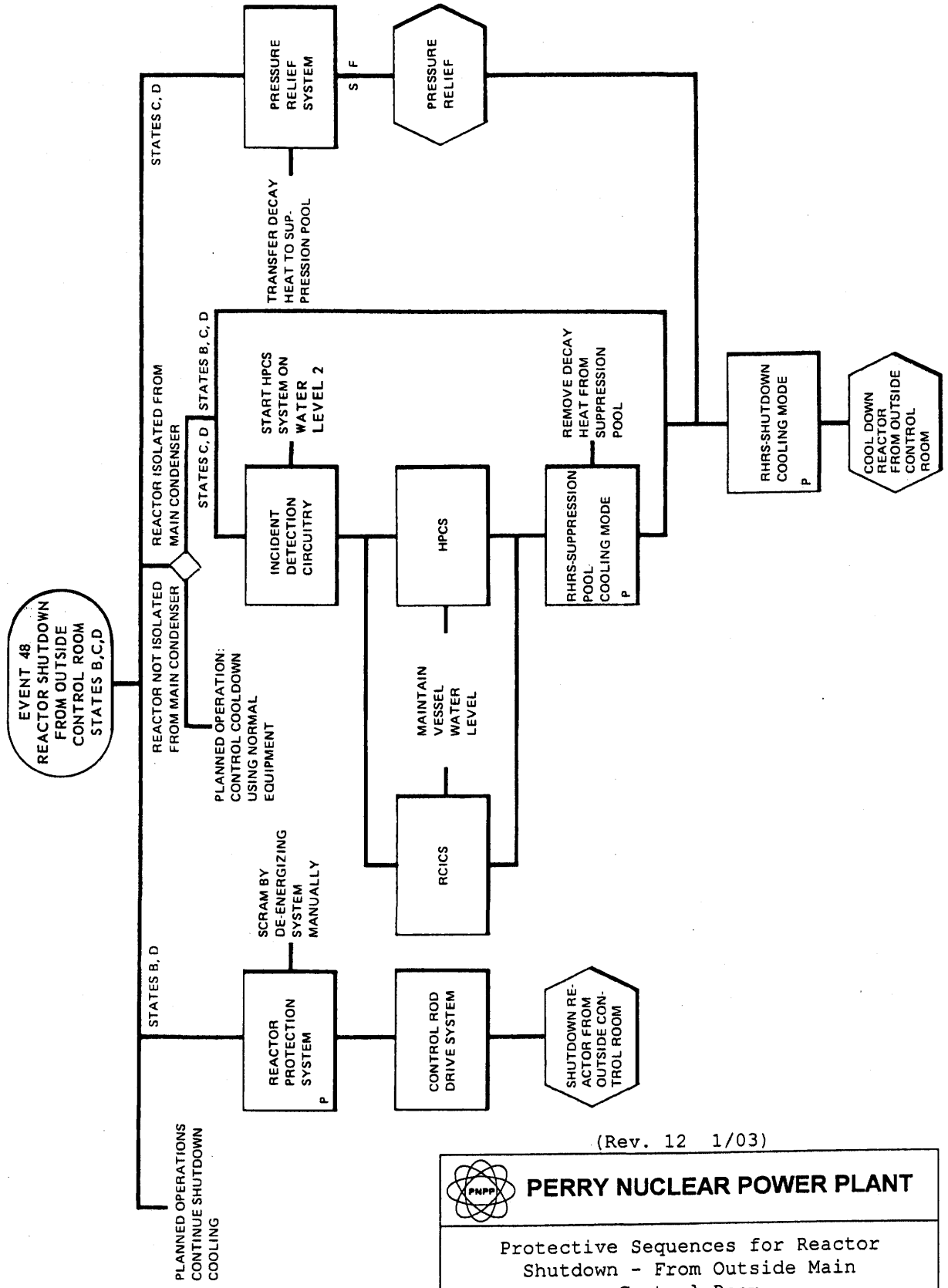

(Rev. 12 1/03)



PERRY NUCLEAR POWER PLANT

Protective Sequences for Reactor
Shutdown - From Outside Main
Control Room

Figure 15A.6-45

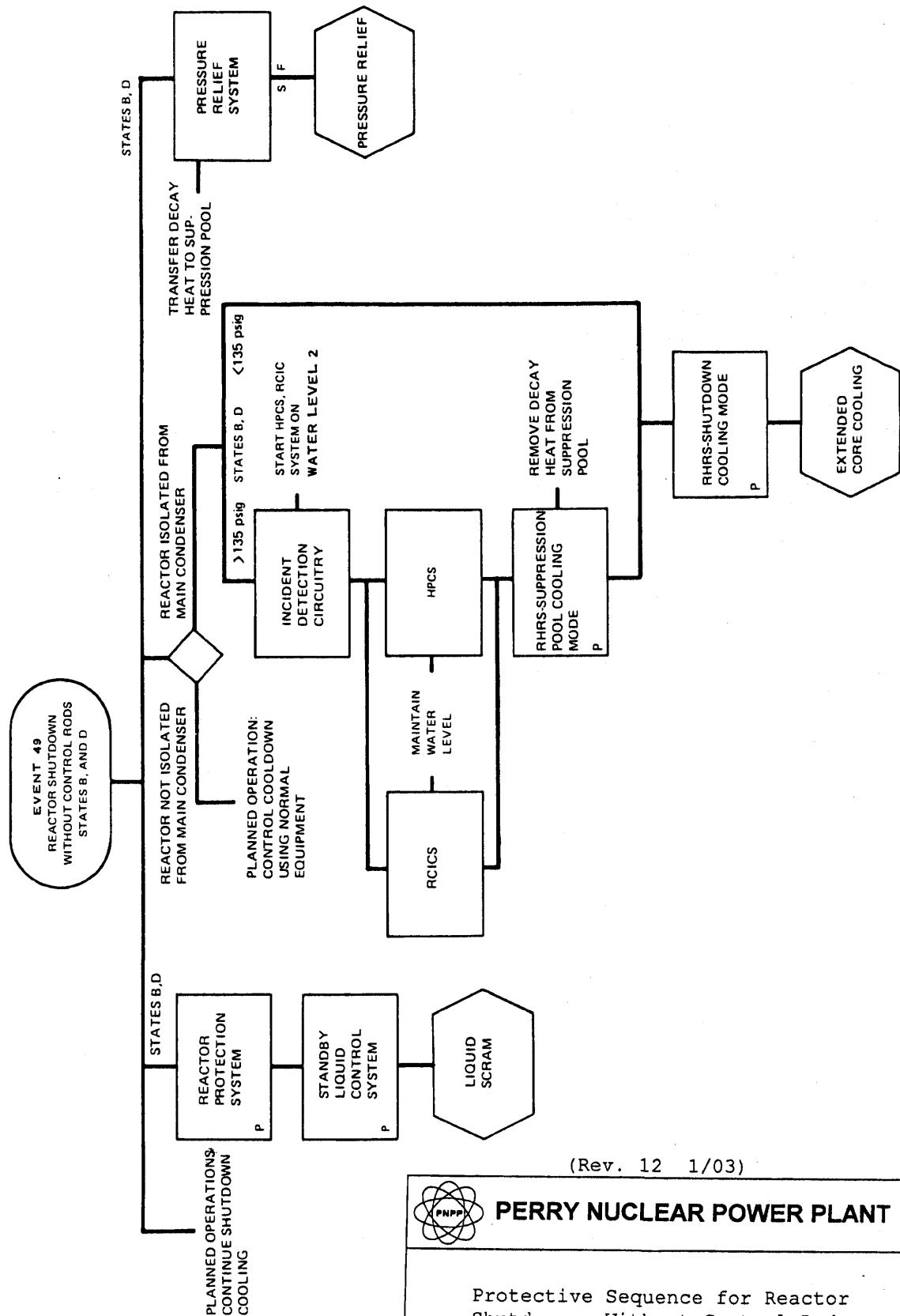

(Rev. 12 1/03)



PERRY NUCLEAR POWER PLANT

Protective Sequence for Reactor
Shutdown - Without Control Rods

Figure 15A.6-46

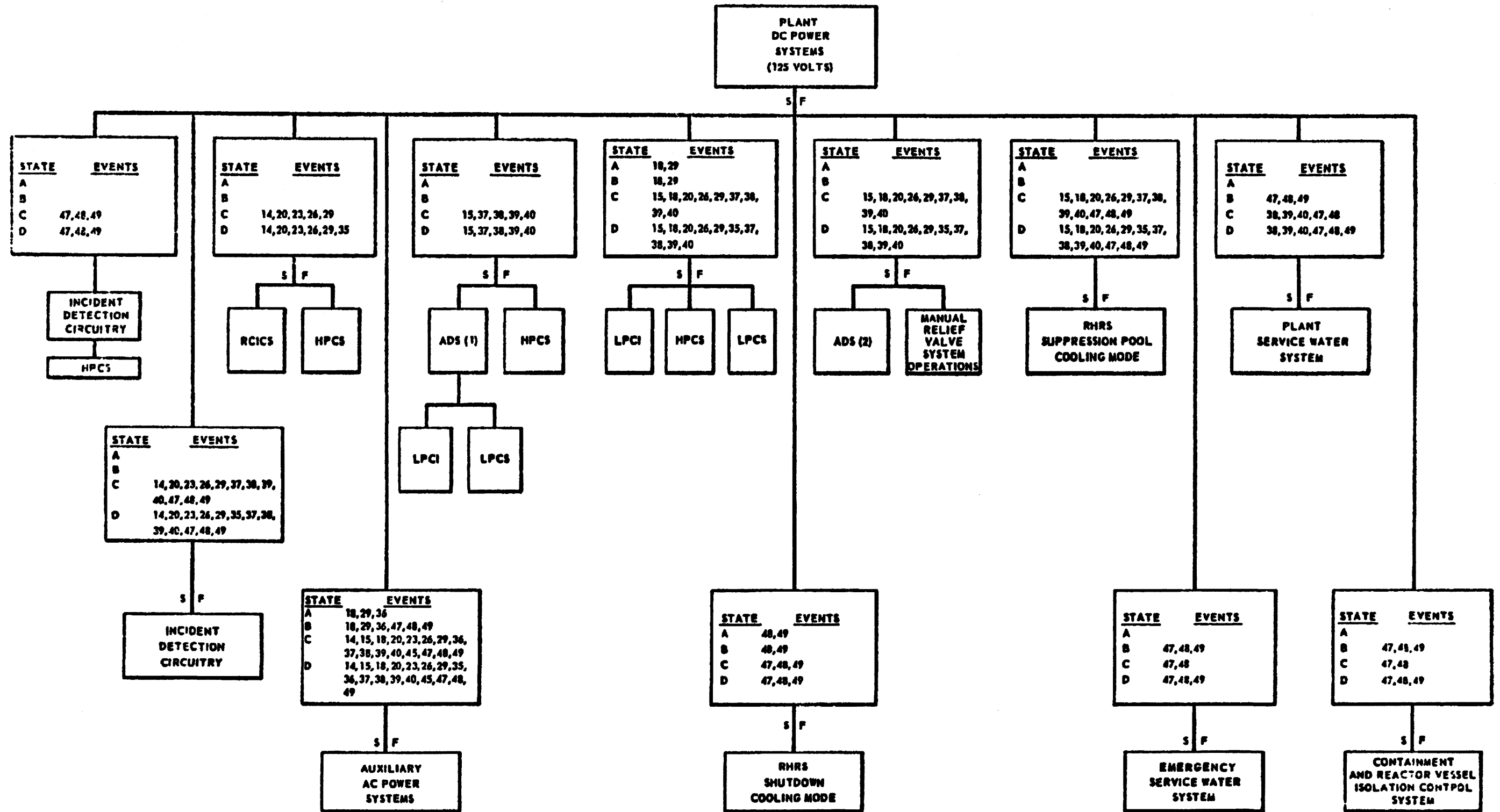

(1) BLOWDOWN.
 (2) CONTROLLED DEPRESSURIZATION.
 (3) SF REQUIREMENT NOT APPLICABLE IN EVENT 51,52,53.

(REV. 19 10/2015)

PERRY NUCLEAR POWER PLANT
 10 CENTER RD., PERRY, OHIO 44081

COMMONALITY OF AUXILIARY SYSTEMS -
 DC POWER SYSTEMS (125 VOLTS)

FIGURE 15A.6-47

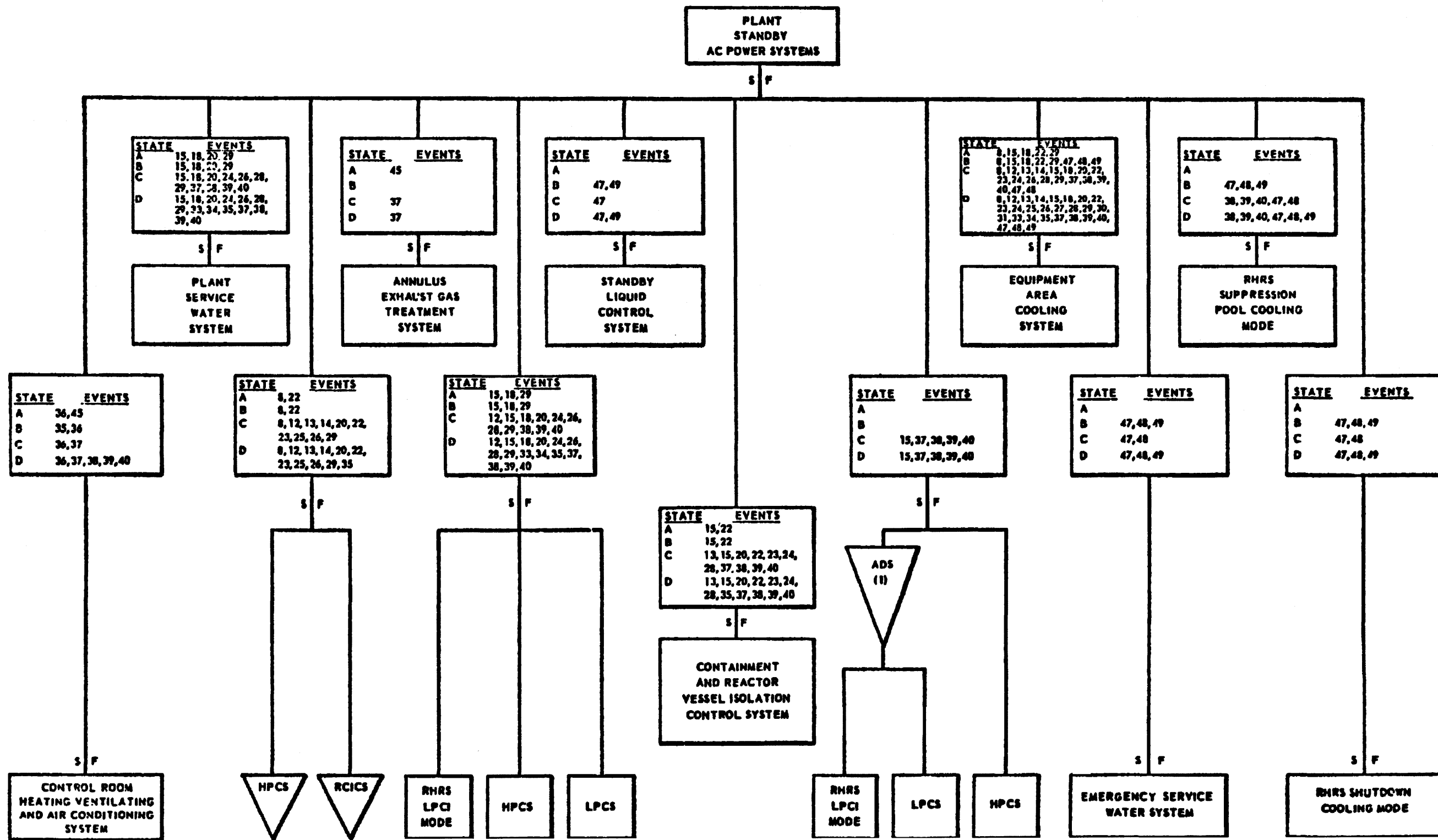

(1) BLOWDOWN
 (2) SF REQUIREMENT NOT APPLICABLE IN EVENT 38.

 INDICATES THAT SYSTEM IS INCLUDED IN COMBINATION BUT DOES NOT REQUIRE THE AUXILIARY POWER.

(REV. 19 10/2015)

PERRY NUCLEAR POWER PLANT
 10 CENTER RD., PERRY, OHIO 44081

COMMONALITY OF STANDBY AC POWER SYSTEMS (120/480/4160 VOLTS)

FIGURE 15A.6-48

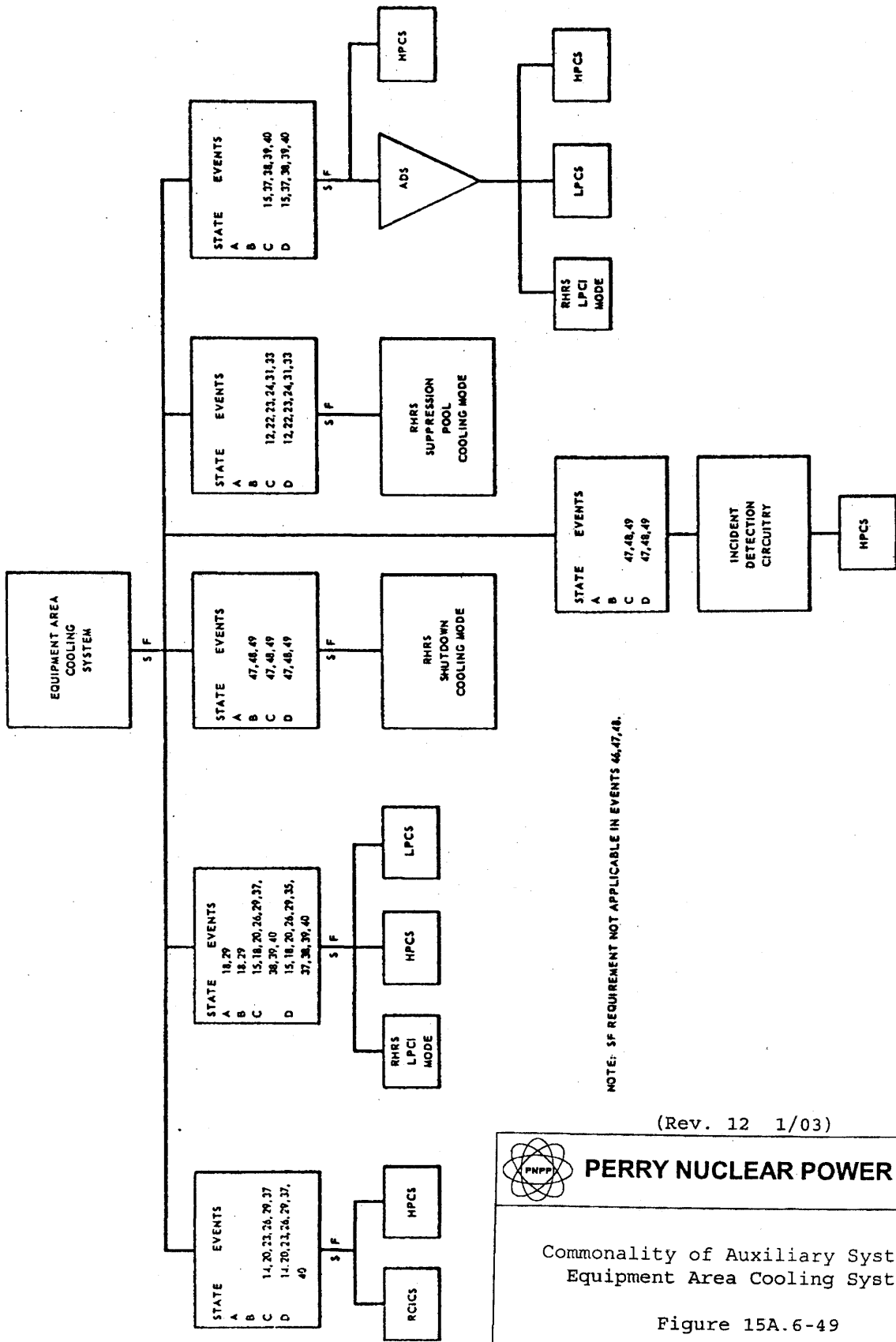

NOTE: SF REQUIREMENT NOT APPLICABLE IN EVENTS 46,47,48.

(Rev. 12 1/03)

PERRY NUCLEAR POWER PLANT

Commonality of Auxiliary Systems -
Equipment Area Cooling Systems

Figure 15A.6-49

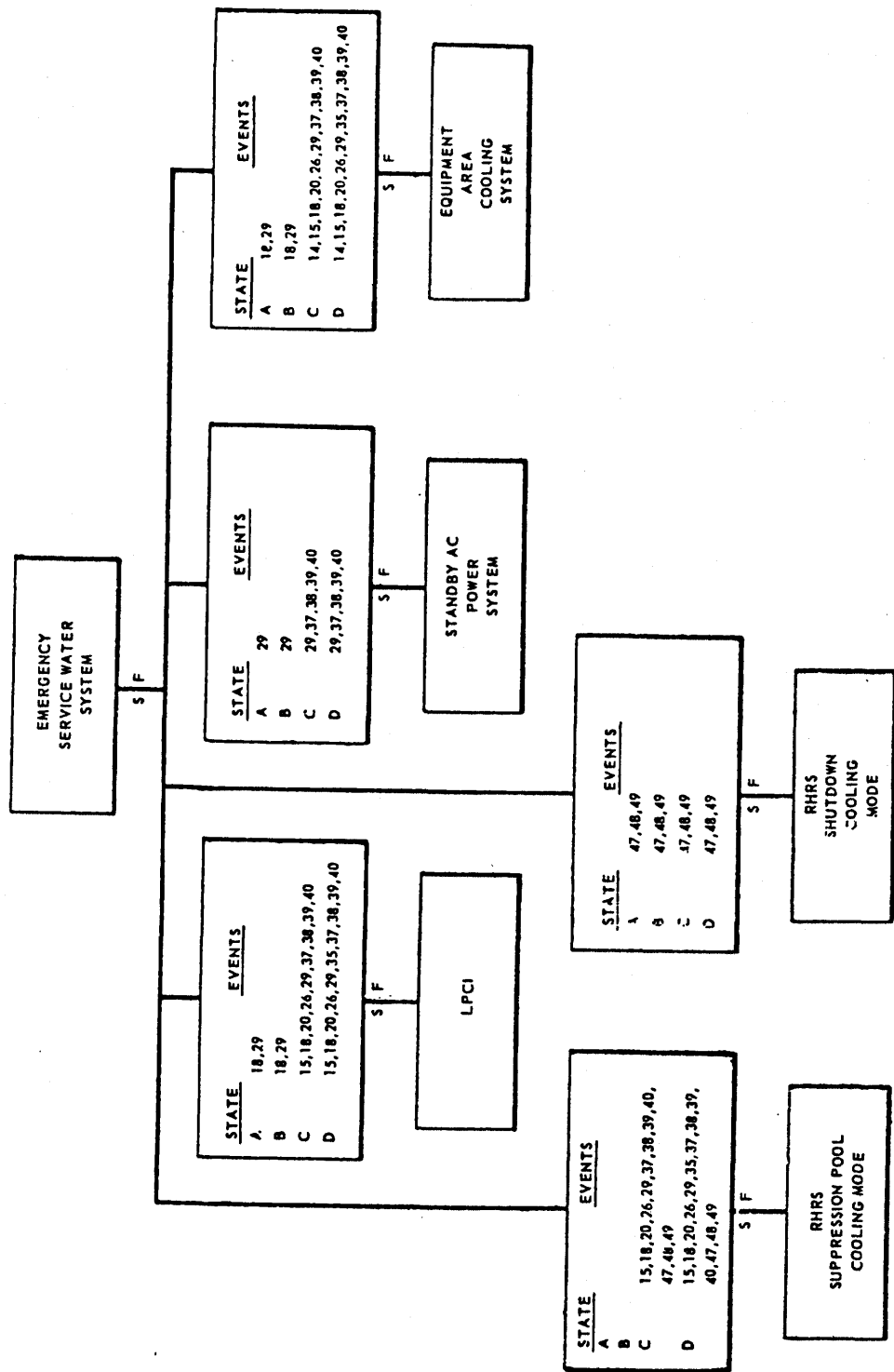

NOTE: SF REQUIREMENT NOT APPLICABLE IN EVENTS 46,47,41.

(Rev. 12 1/03)



PERRY NUCLEAR POWER PLANT

Commonality of Auxiliary Systems -
Plant Service Water System

Figure 15A.6-50

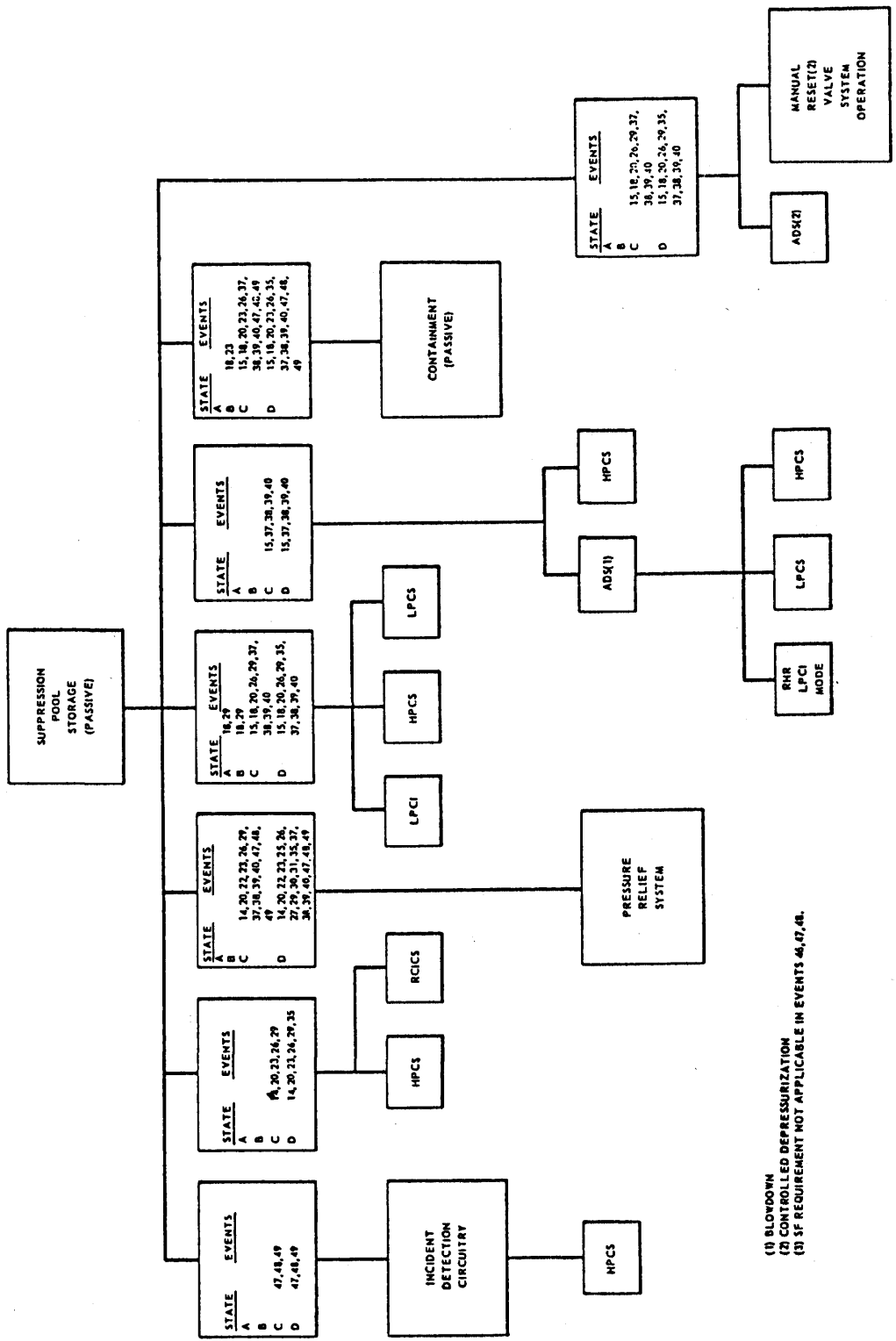

(1) BLOWDOWN
 (2) CONTROLLED DEPRESSURIZATION
 (3) SF REQUIREMENT NOT APPLICABLE IN EVENTS 46, 47, 48.

(Rev. 12 1/03)

PERRY NUCLEAR POWER PLANT

Commonality of Auxiliary Systems -
Suppression Pool Storage

Figure 15A.6-51

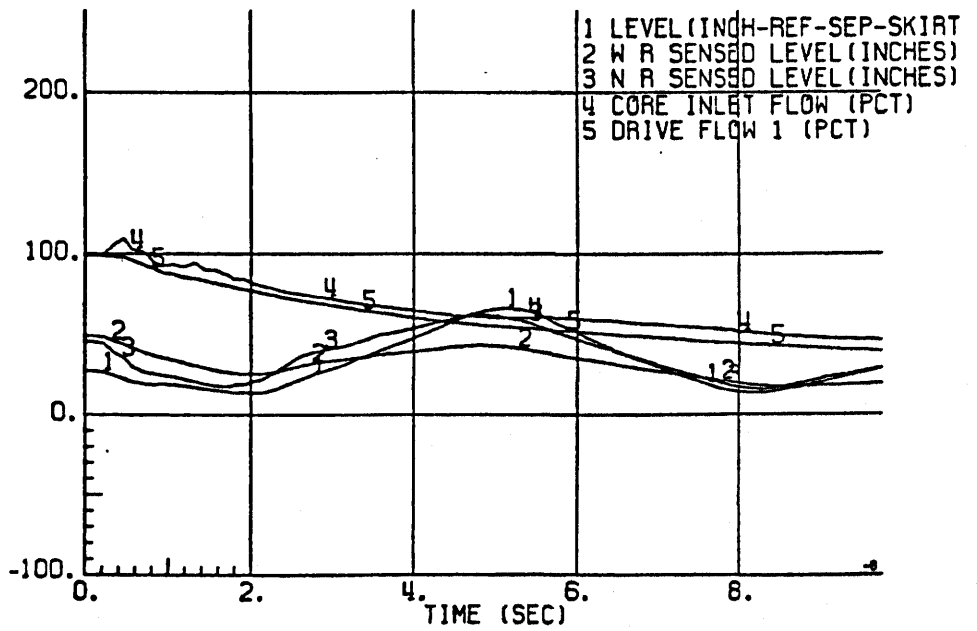
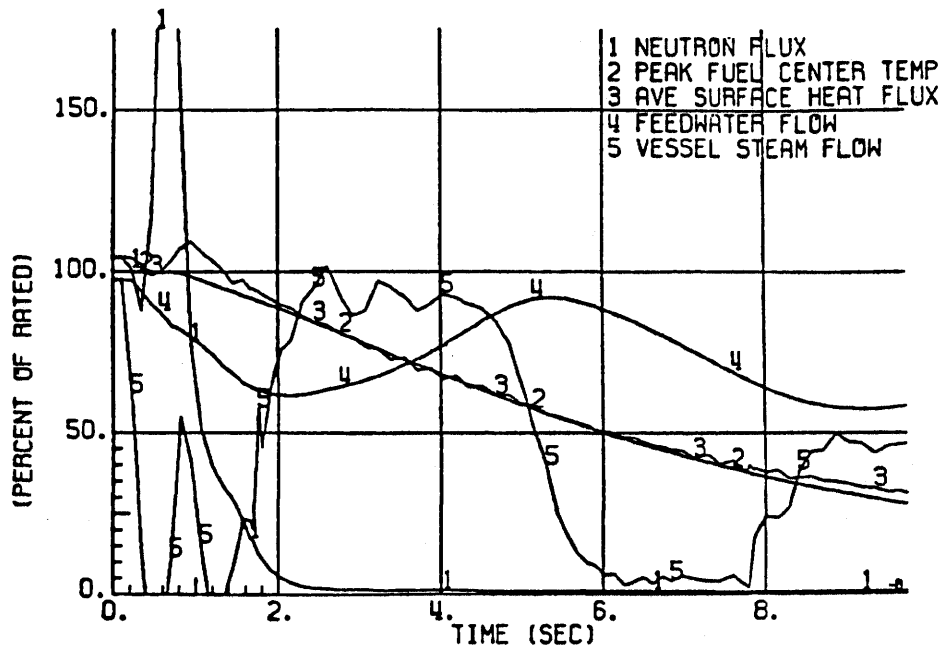

(Rev. 12 1/03)



PERRY NUCLEAR POWER PLANT

Generator Load Rejection with
Bypass Failure 3729 Mwt Core Power
100% Flow 370°F Rated FWT

Figure 15D-1 (Sheet 1 of 2)

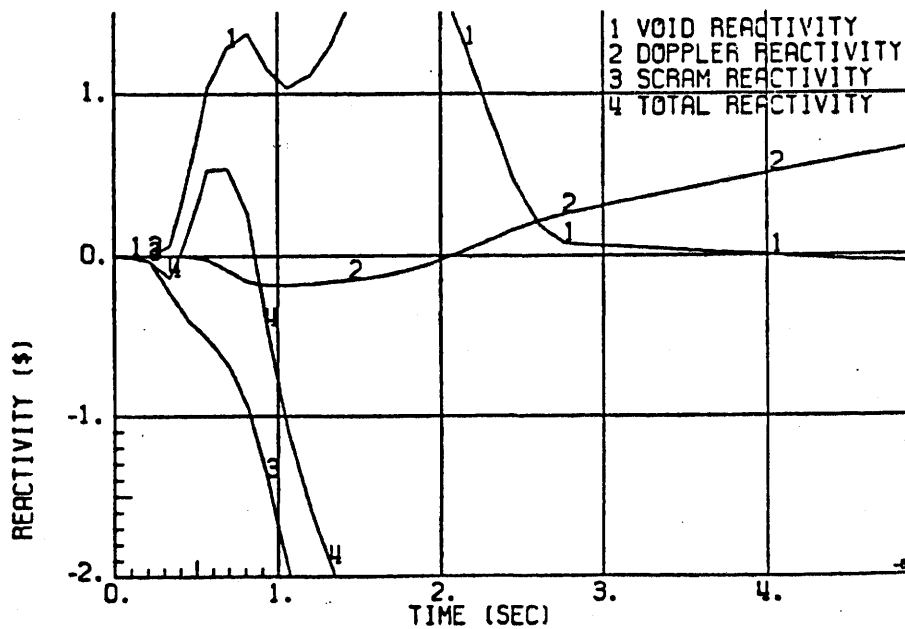
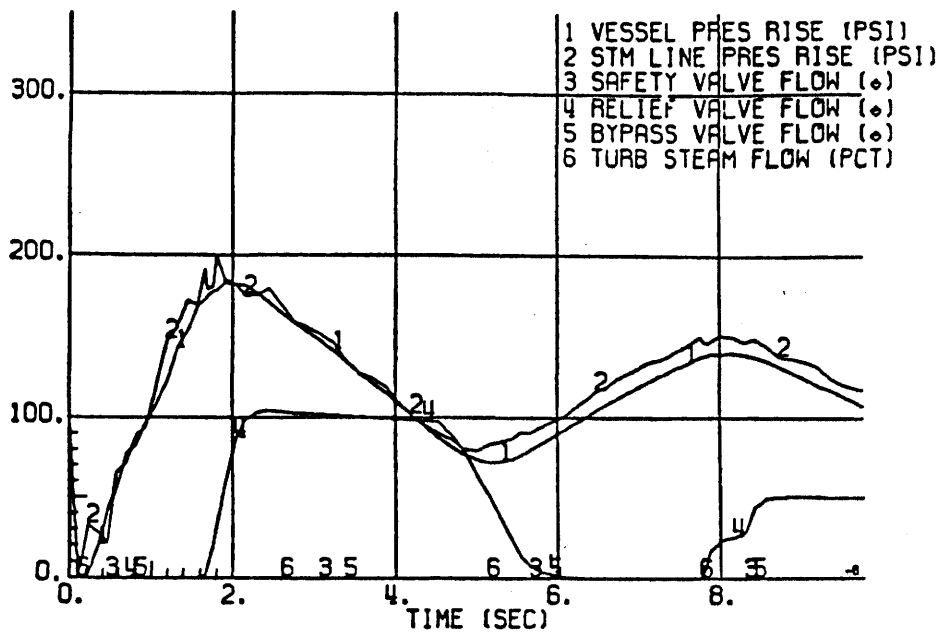

(Rev. 12 1/03)



PERRY NUCLEAR POWER PLANT

Generator Load Rejection with
 Bypass Failure 3729 Mwt Core Power
 100% Flow 370°F Rated FWT

Figure 15D-1 (Sheet 2 of 2)

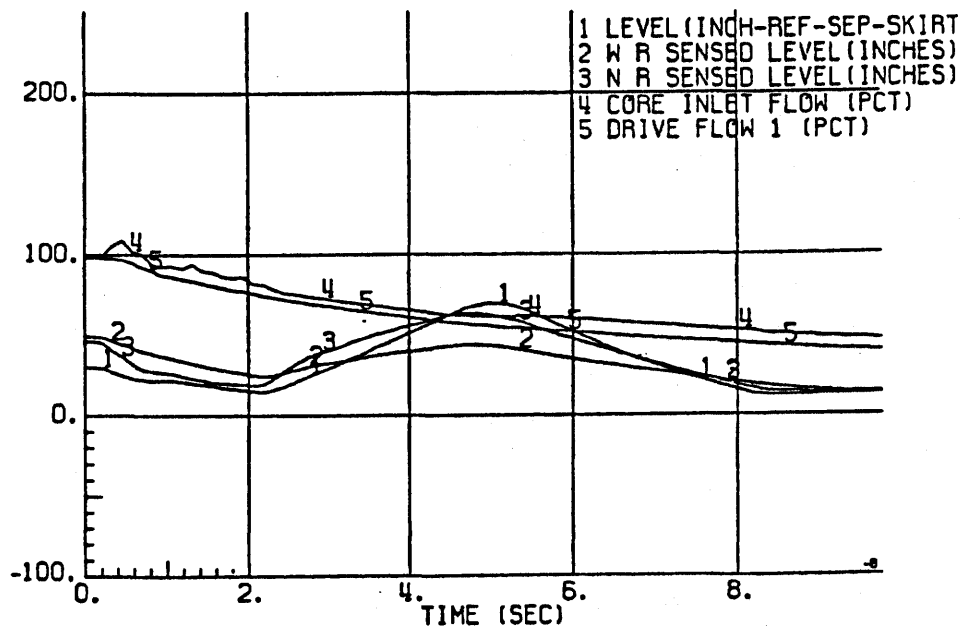
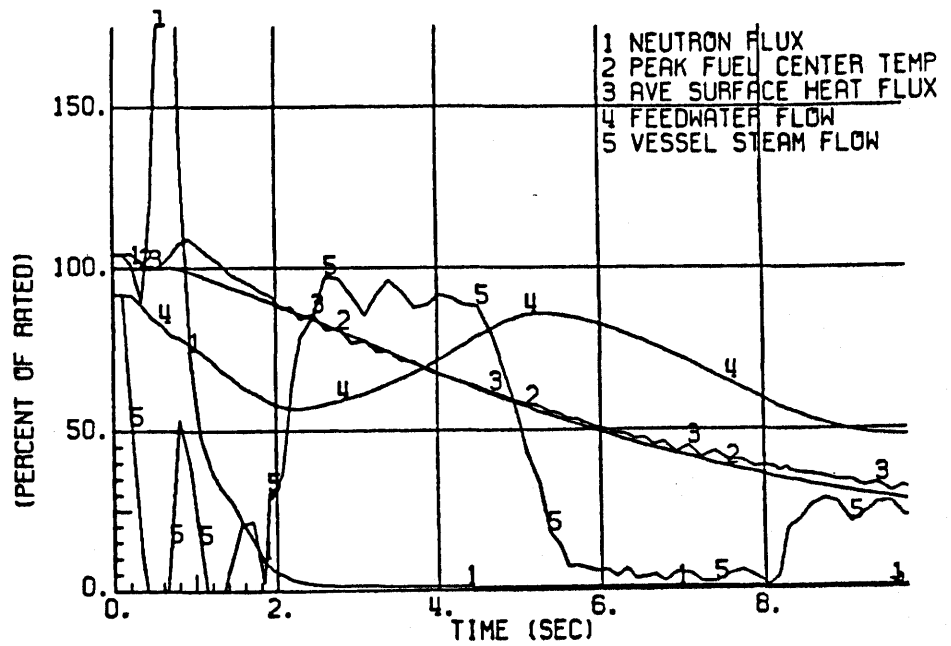

(Rev. 12 1/03)



PERRY NUCLEAR POWER PLANT

Generator Load Rejection with
Bypass Failure 3729 MWt Core Power
100% Flow 320°F Rated FWT

Figure 15D-2 (Sheet 1 of 2)

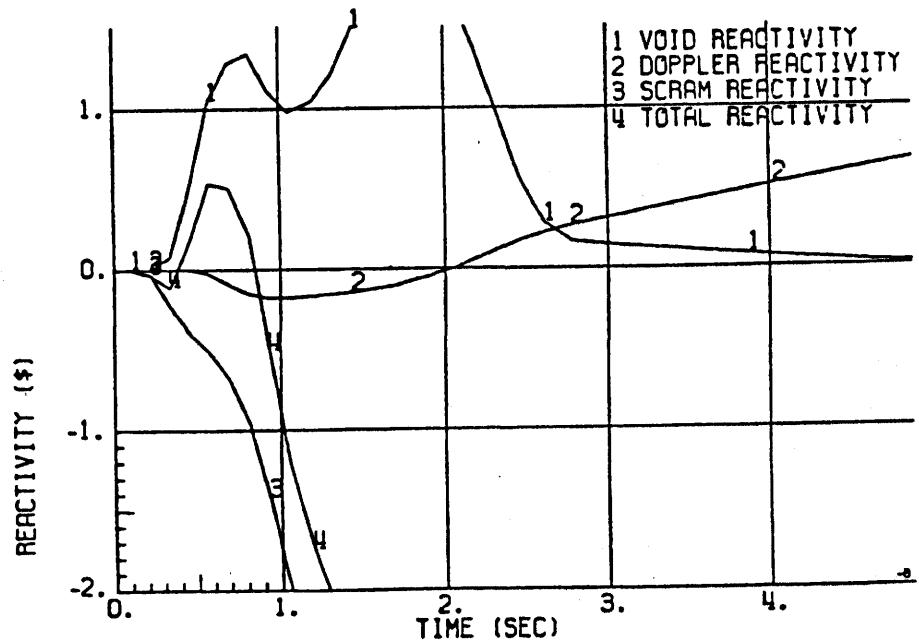
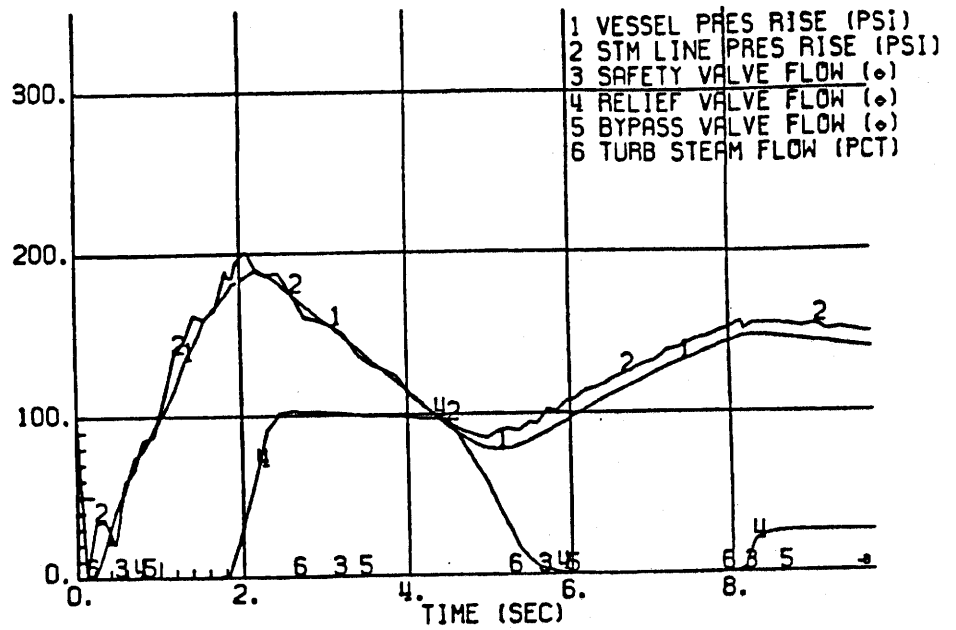

(Rev. 12 1/03)



PERRY NUCLEAR POWER PLANT

Generator Load Rejection with
 Bypass Failure 3729 Mwt Core Power
 100% Flow 320°F Rated FWT

Figure 15D-2 (Sheet 2 of 2)

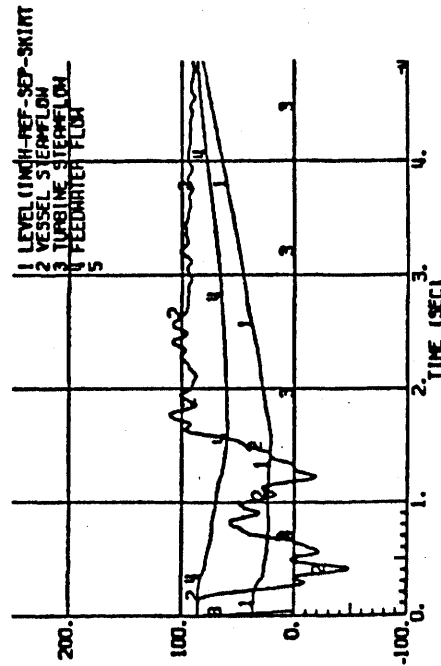
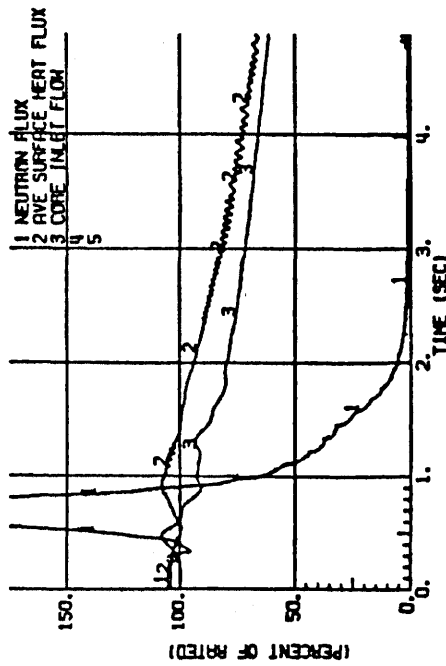
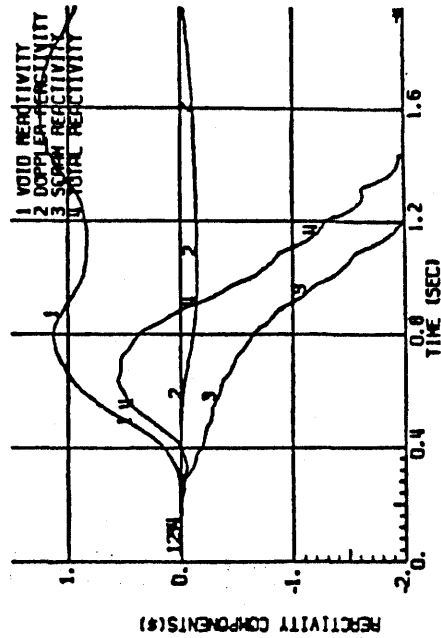
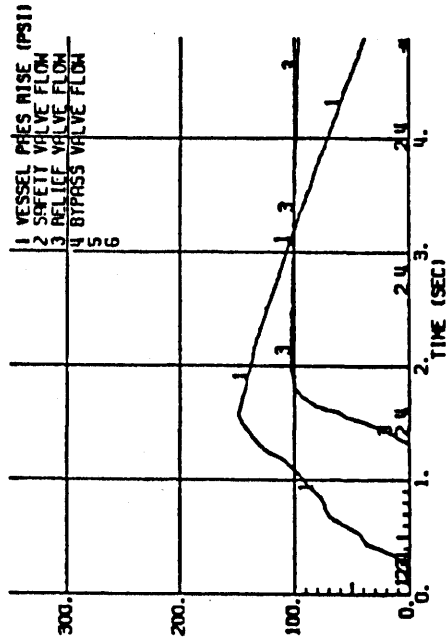

(Rev. 12 1/03)



PERRY NUCLEAR POWER PLANT

Generator Load Rejection with
Bypass Failure 3729 Mwt Core Power
100% Flow 250°F Rated FWT

Figure 15D-3a

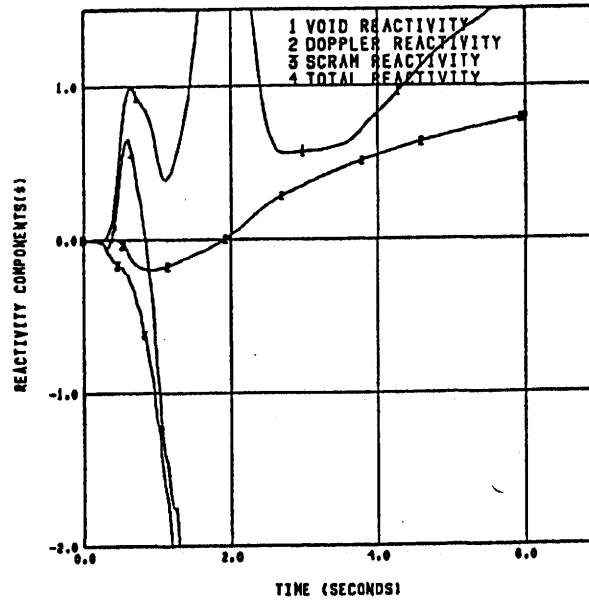
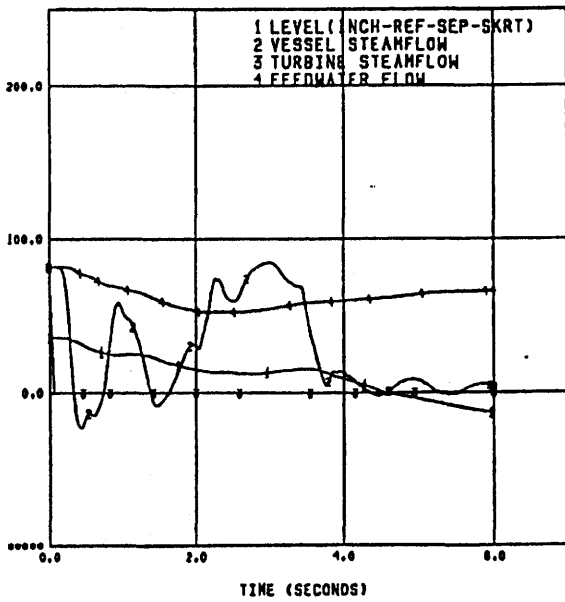
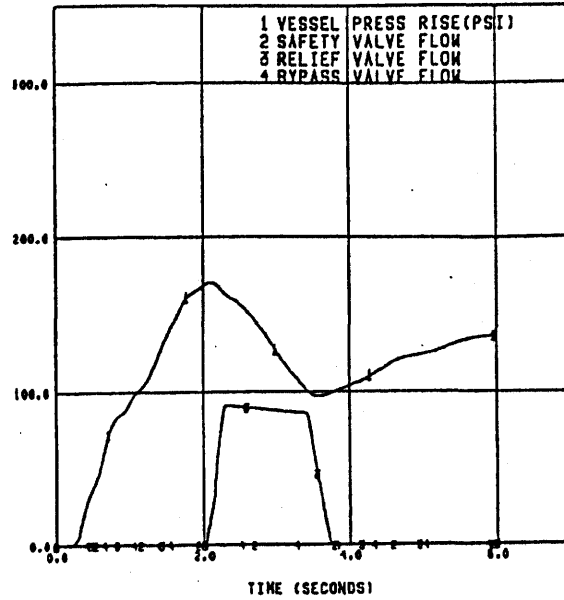
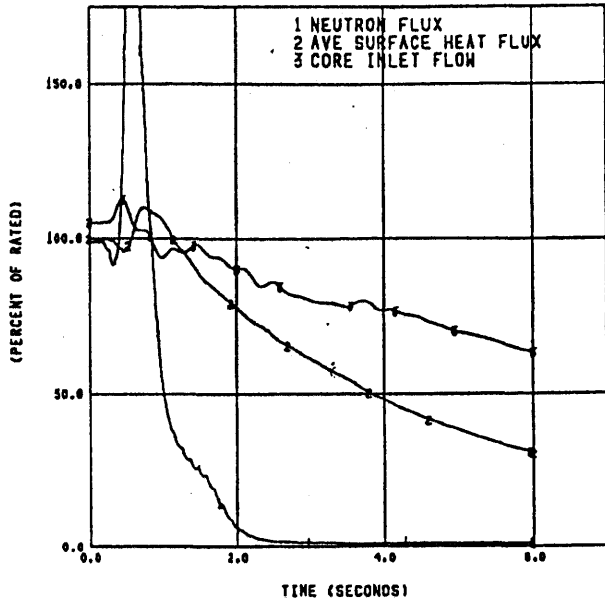

(Rev. 12 1/03)



PERRY NUCLEAR POWER PLANT

Generator Load Rejection with
Bypass Failure for Power Uprate
100% Power, 105% Flow, 255.5°F FWT

Figure 15D-3b

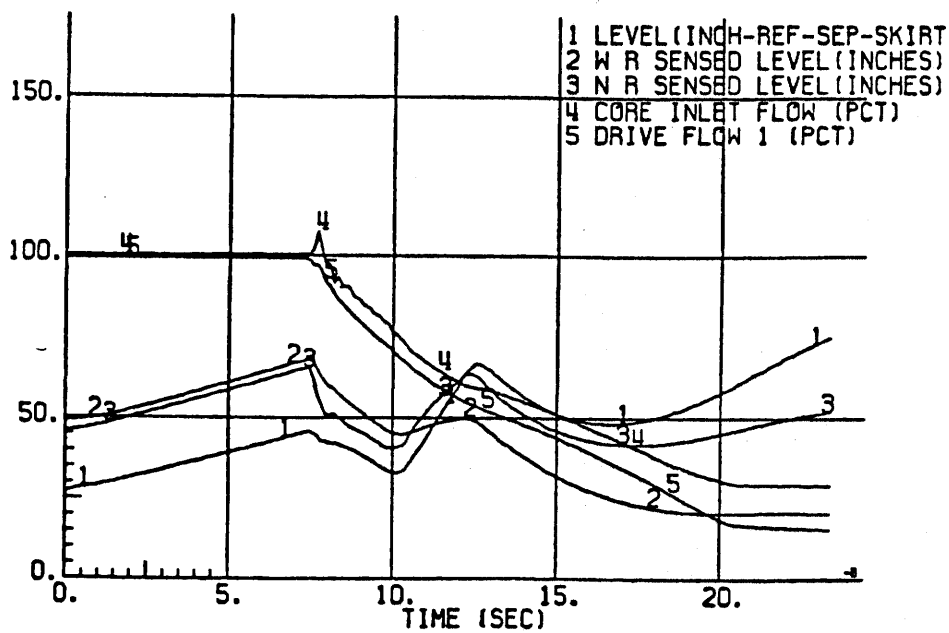
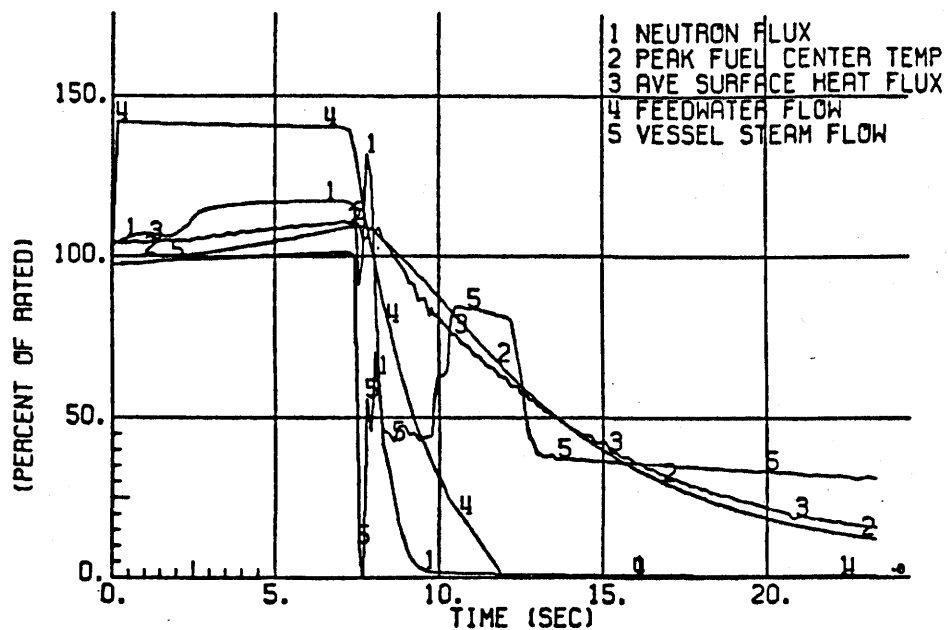

(Rev. 12 1/03)



PERRY NUCLEAR POWER PLANT

Feedwater Controller Failure
3729 MWt Core Power 100% Flow
370°F Rated FWT

Figure 15D-4 (Sheet 1 of 2)

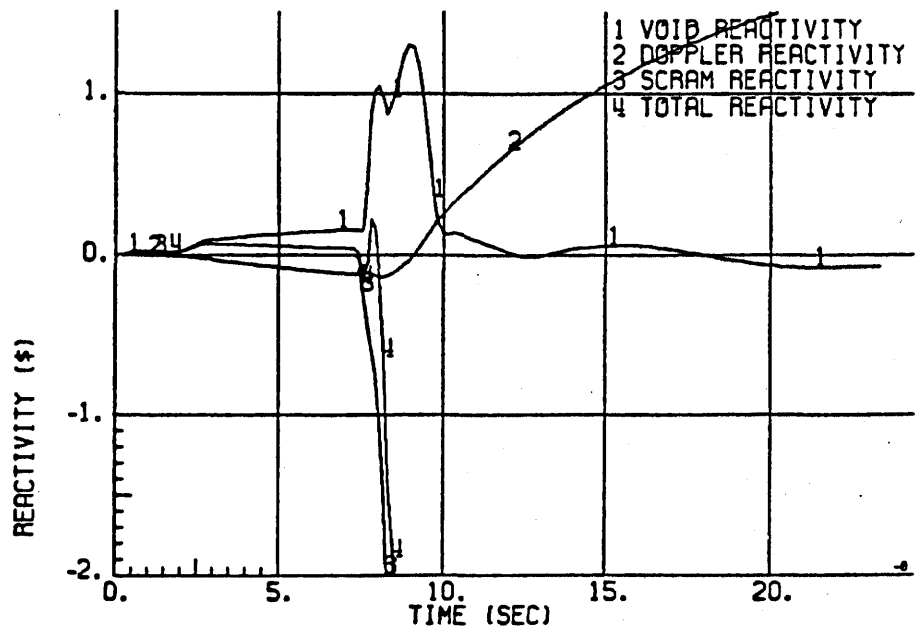
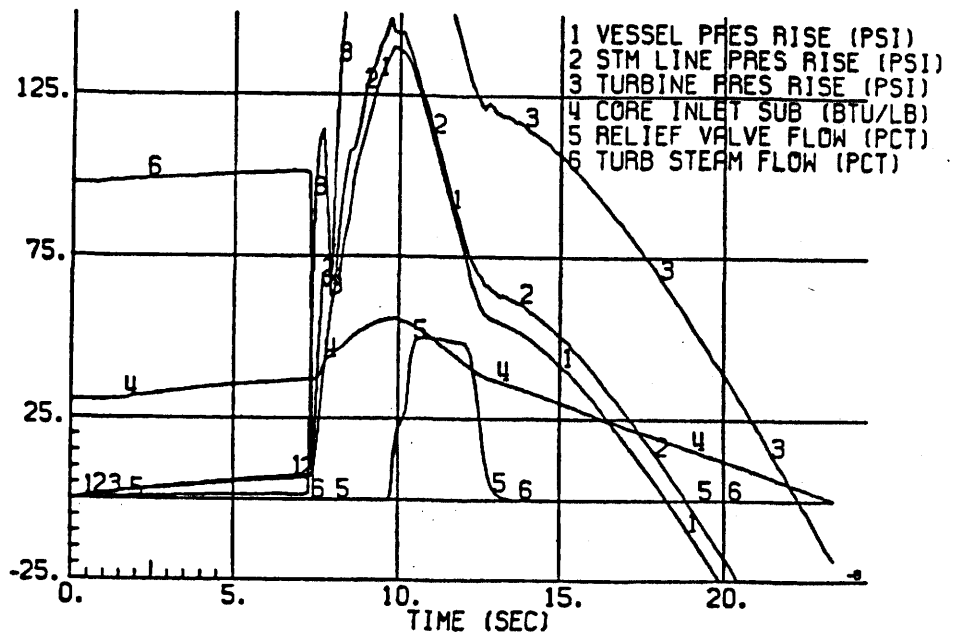

(Rev. 12 1/03)



PERRY NUCLEAR POWER PLANT

Feedwater Controller Failure
 3729 MWt Core Power 100% Flow
 370°F Rated FWT

Figure 15D-4 (Sheet 2 of 2)

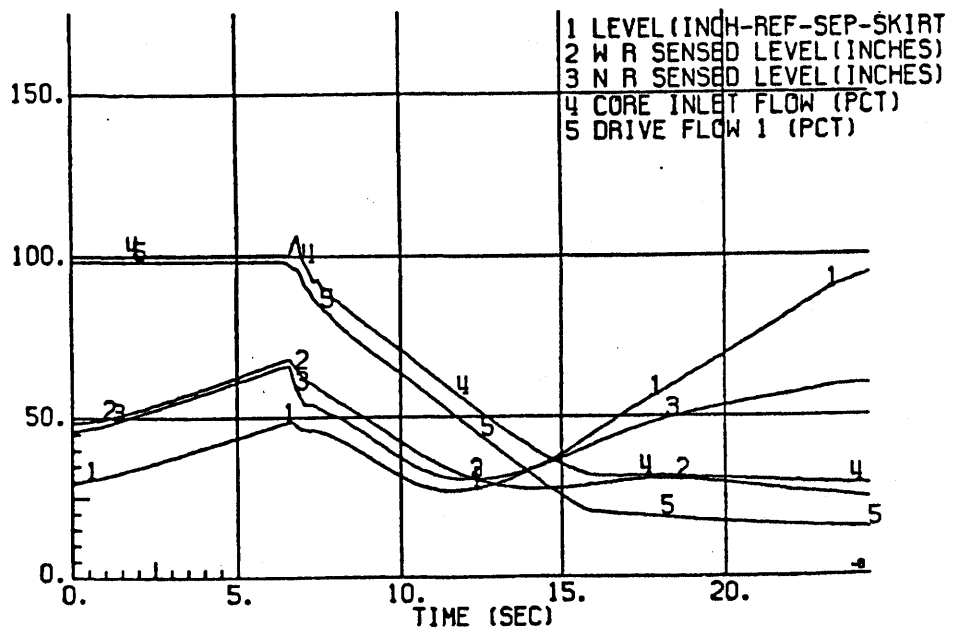
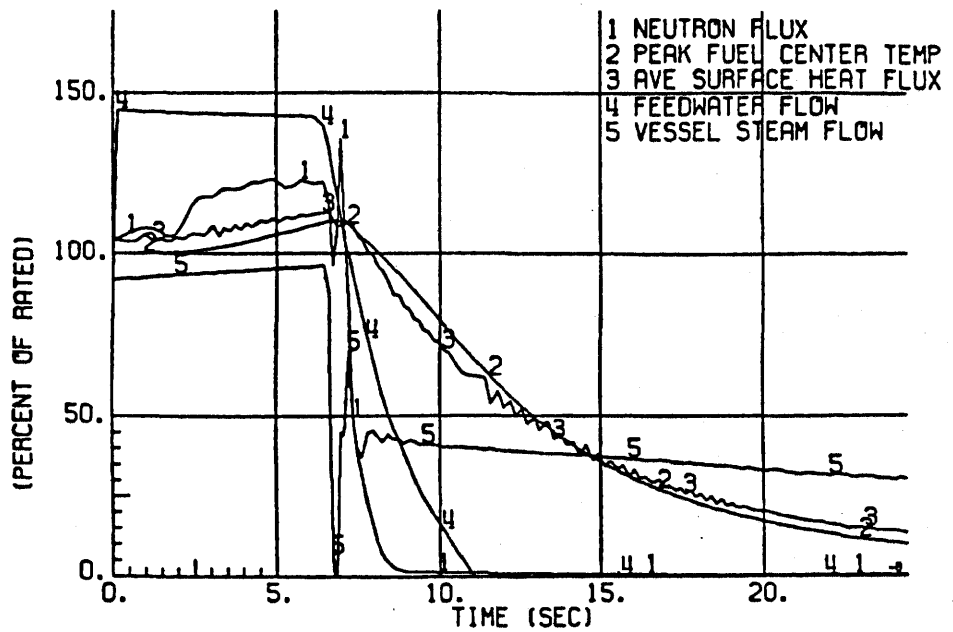

(Rev. 12 1/03)



PERRY NUCLEAR POWER PLANT

Feedwater Controller Failure
3729 MWt Core Power 100% Flow
320°F Rated FWT

Figure 15D-5 (Sheet 1 of 2)

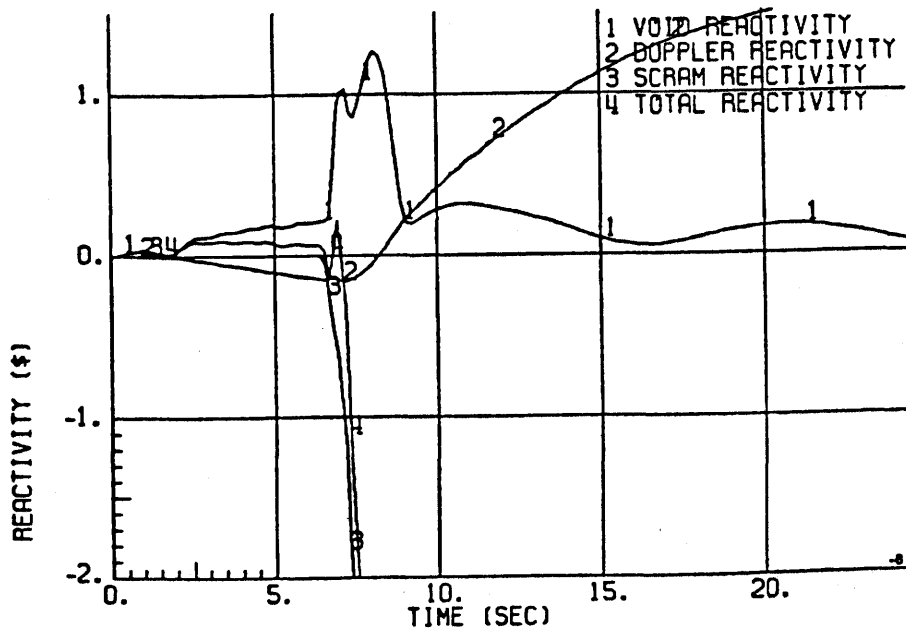
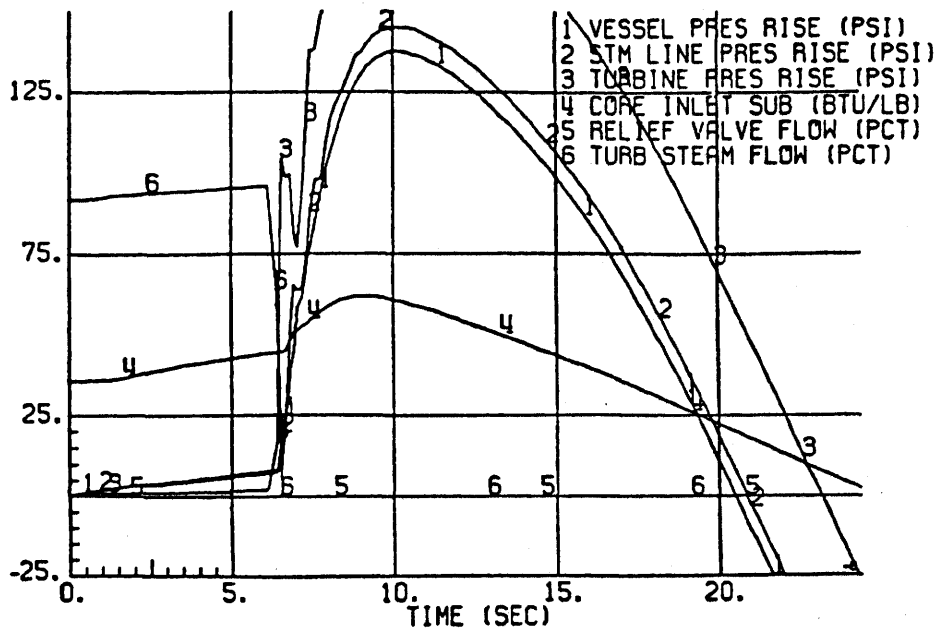

(Rev. 12 1/03)



PERRY NUCLEAR POWER PLANT

Feedwater Controller Failure
 3729 MWt Core Power 100% Flow
 320°F Rated FWT

Figure 15D-5 (Sheet 2 of 2)

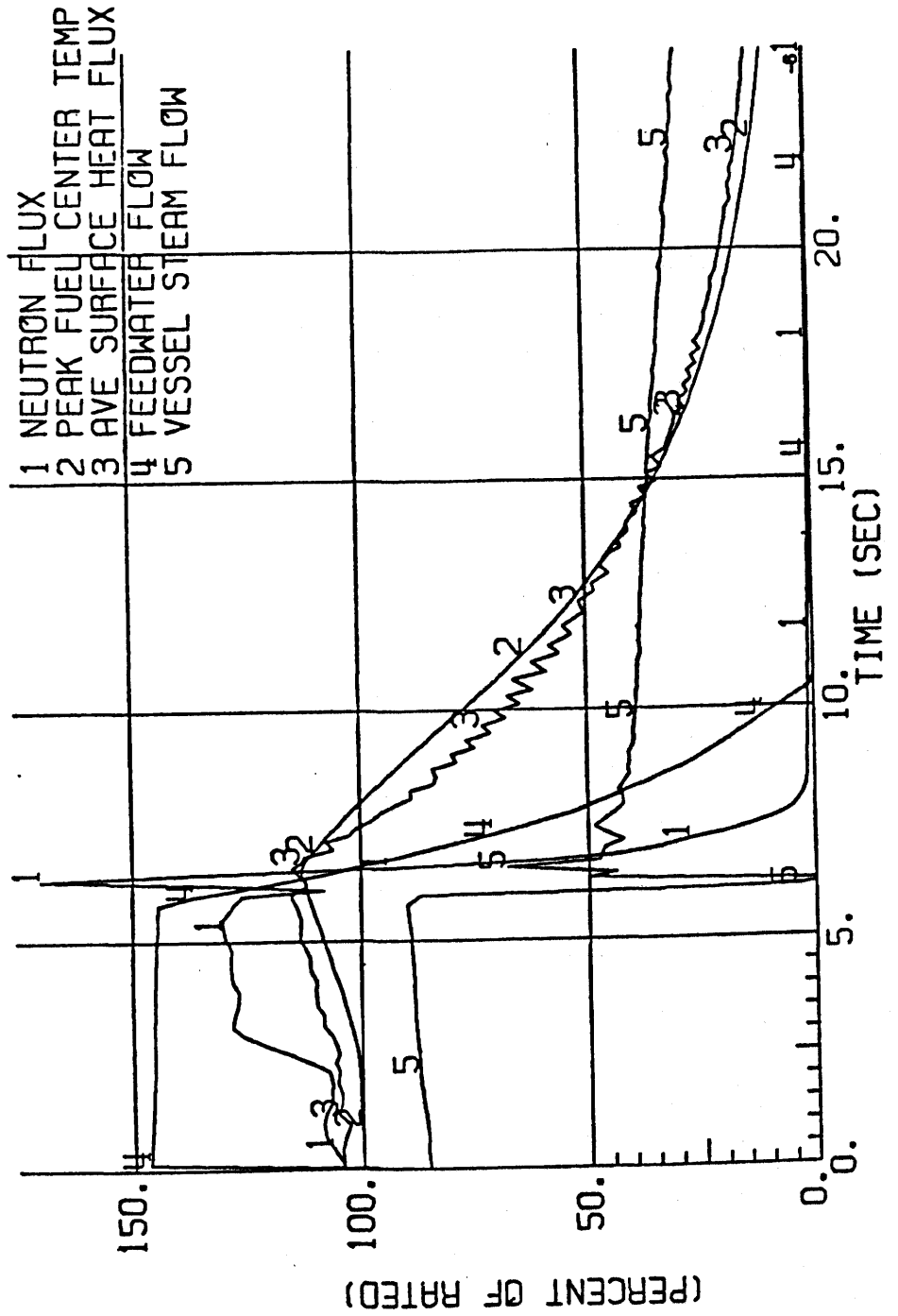

(Rev. 12 1/03)



PERRY NUCLEAR POWER PLANT

Feedwater Controller Failure
3729 MWt Core Power 100% Flow
250°F Rated FWT

Figure 15D-6a (Sheet 1 of 4)

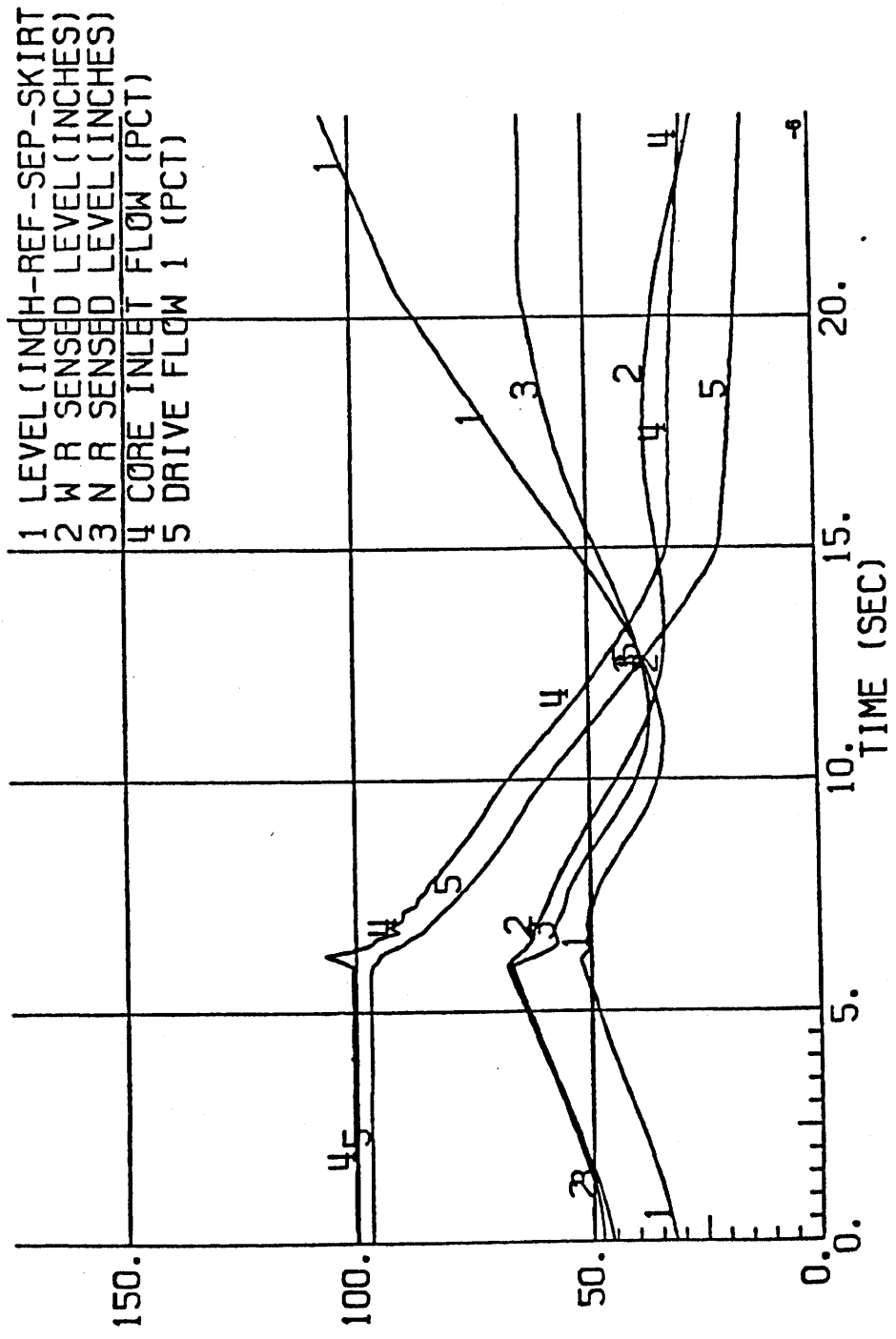

(Rev. 12 1/03)

	PERRY NUCLEAR POWER PLANT
Feedwater Controller Failure 3729 MWt Core Power 100% Flow 250°F Rated FWT	
Figure 15D-6a (Sheet 2 of 4)	

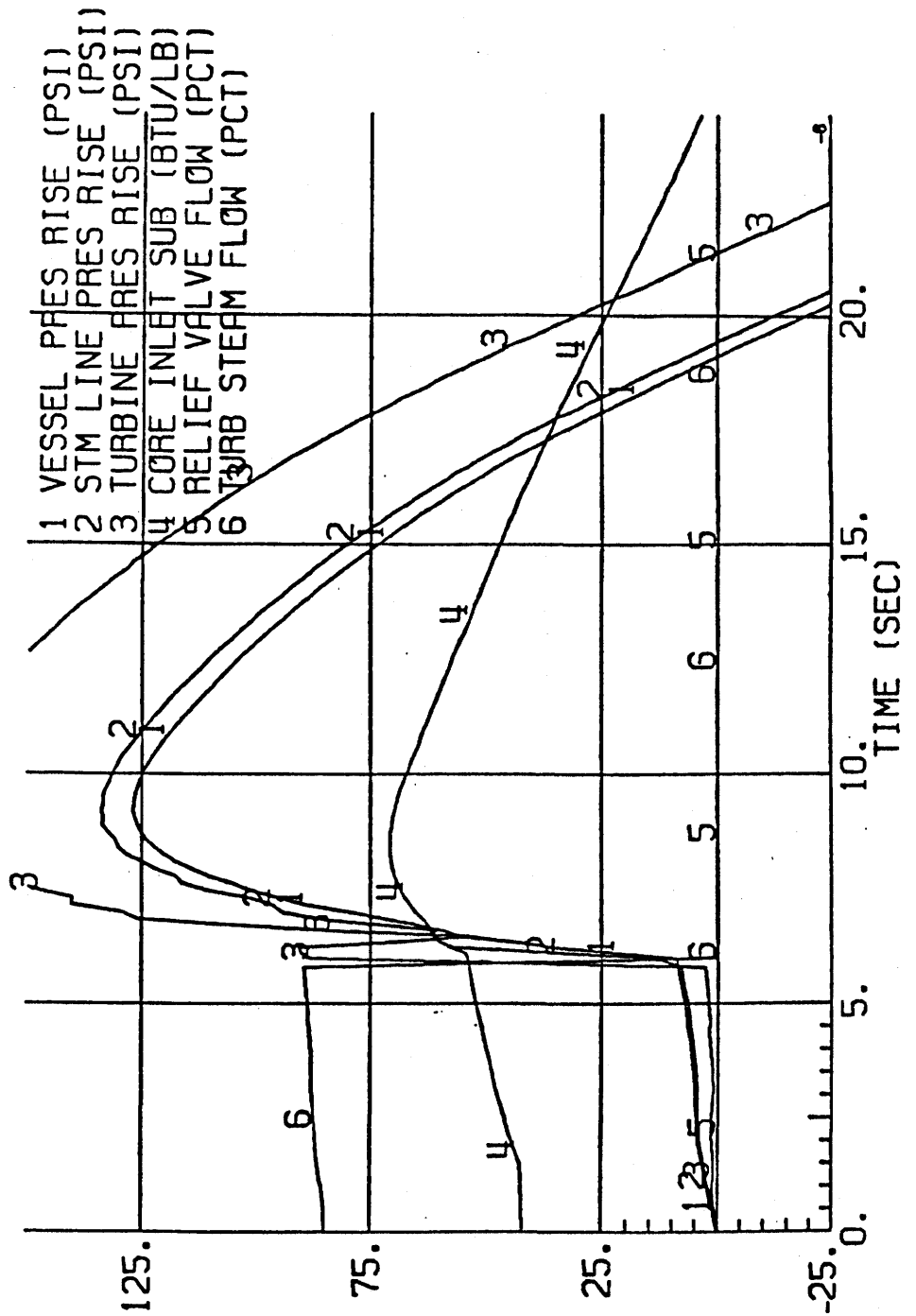

(Rev. 12 1/03)



PERRY NUCLEAR POWER PLANT

Feedwater Controller Failure
 3729 MWt Core Power 100% Flow
 250°F Rated FWT

Figure 15D-6a (Sheet 3 of 4)

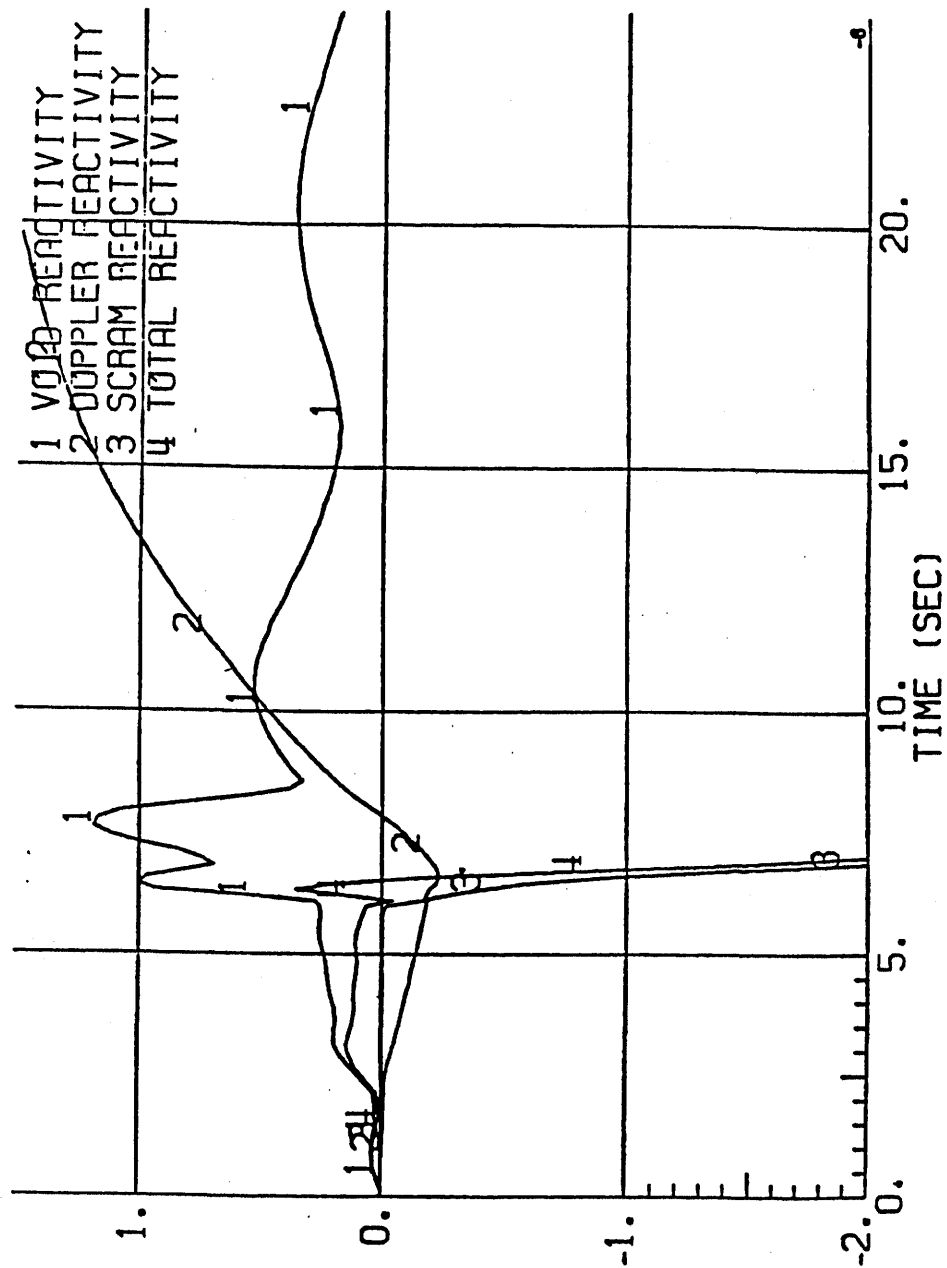

(Rev. 12 1/03)



PERRY NUCLEAR POWER PLANT

Feedwater Controller Failure
3729 MWt Core Power 100% Flow
250°F Rated FWT

Figure 15D-6a (Sheet 4 of 4)

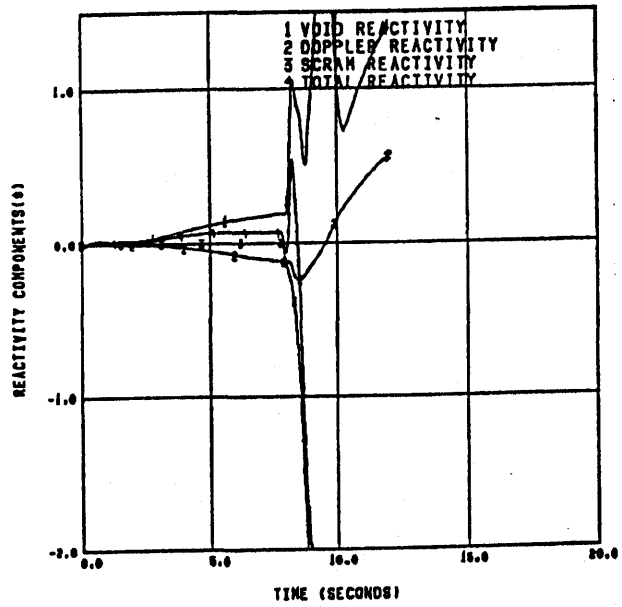
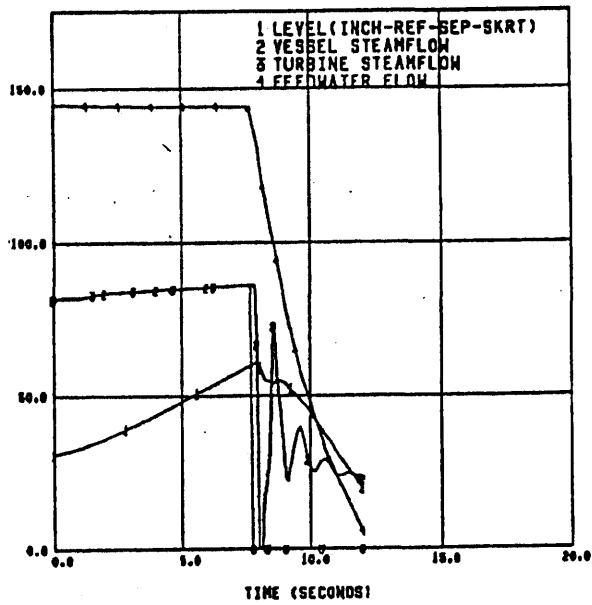
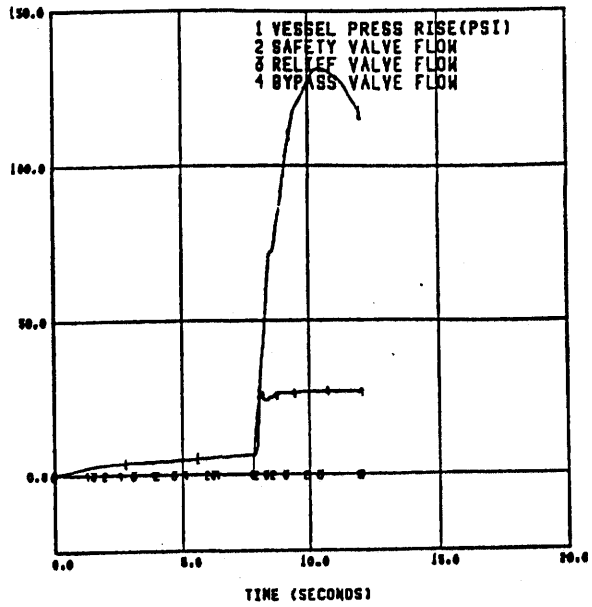
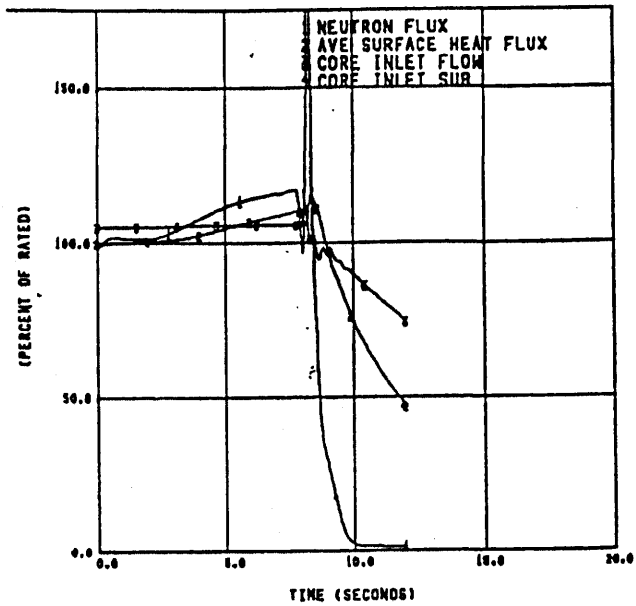

(Rev. 12 1/03)



PERRY NUCLEAR POWER PLANT

Feedwater Controller Failure
for Power Uprate 100% Power,
105% Flow, 255.5°F FWT

Figure 15D-6b

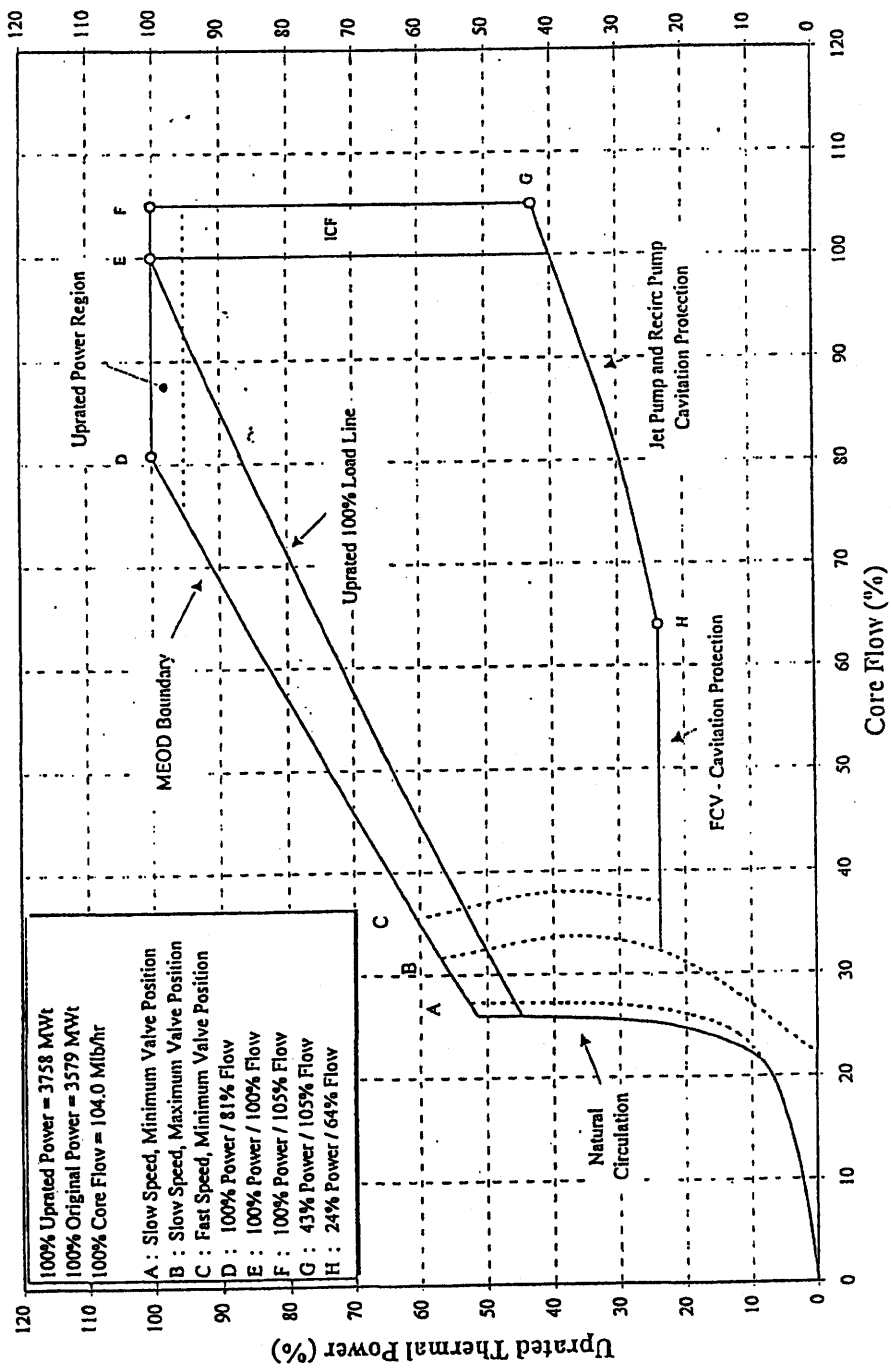

(Rev. 12 1/03)



PERRY NUCLEAR POWER PLANT

Maximum Extended Operating
 Domain Power/Flow Map

Figure 15E.2-1

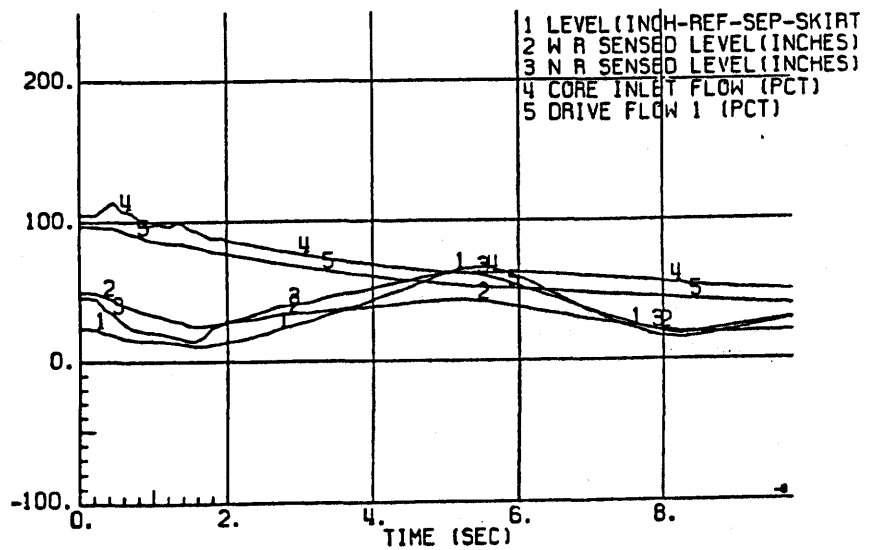
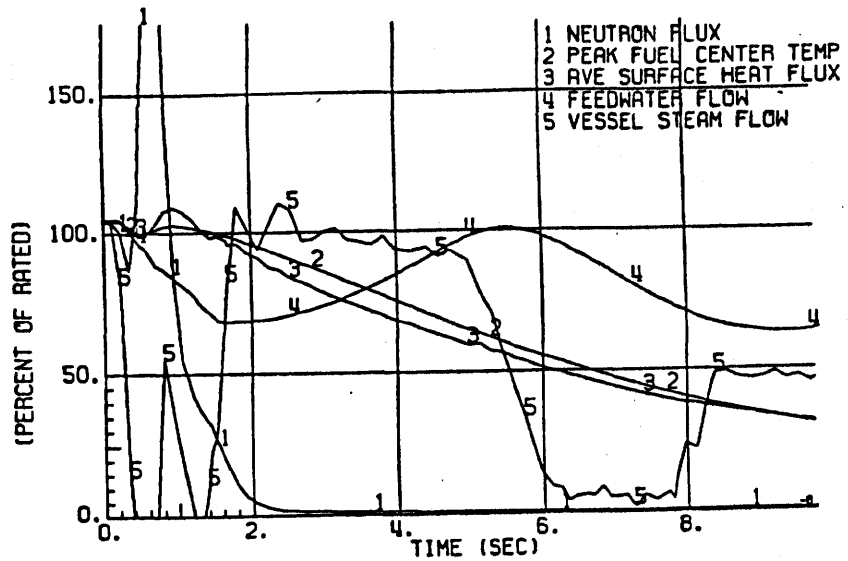

(Rev. 12 1/03)



PERRY NUCLEAR POWER PLANT

Generator Load Rejection
W/O Bypass 3729 MWt Core Power
105% Core Flow

Figure 15E.3-1 (Sheet 1 of 2)

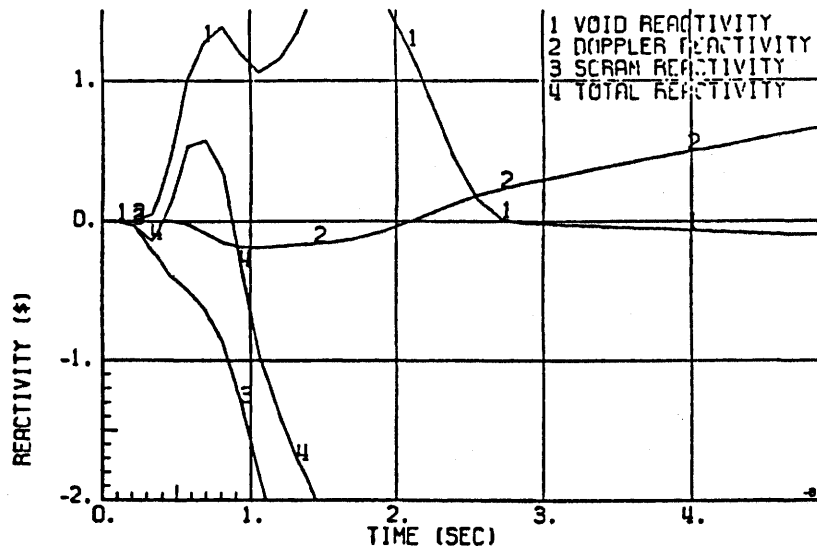
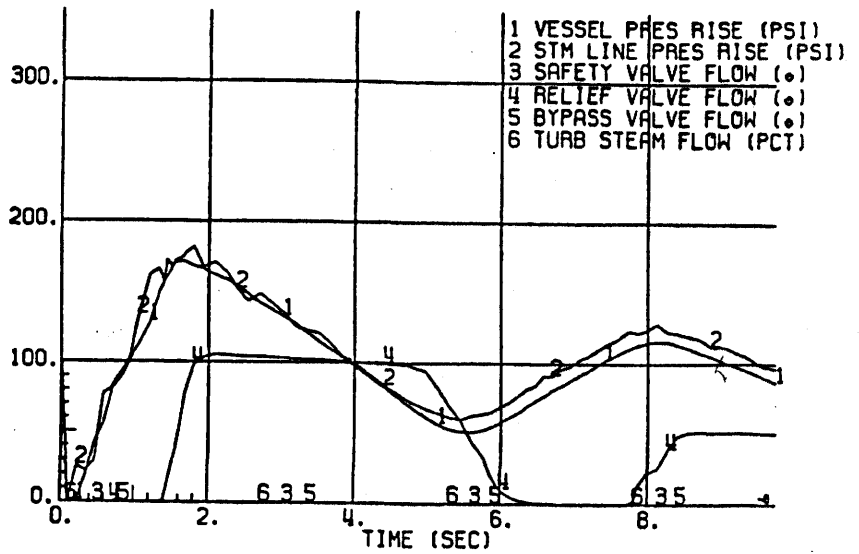

(Rev. 12 1/03)



PERRY NUCLEAR POWER PLANT

Generator Load Rejection
 W/O Bypass 3729 MWt Core Power
 105% Core Flow

Figure 15E.3-1 (Sheet 2 of 2)

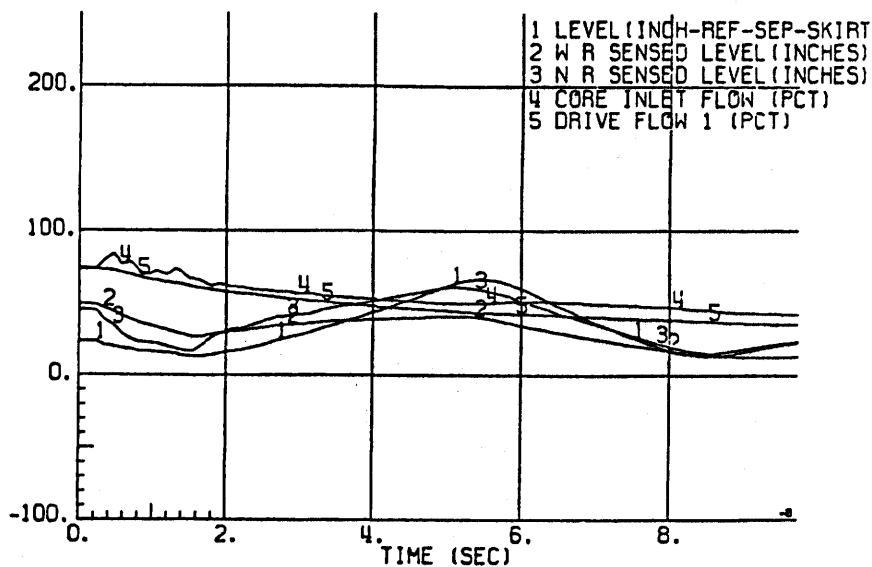
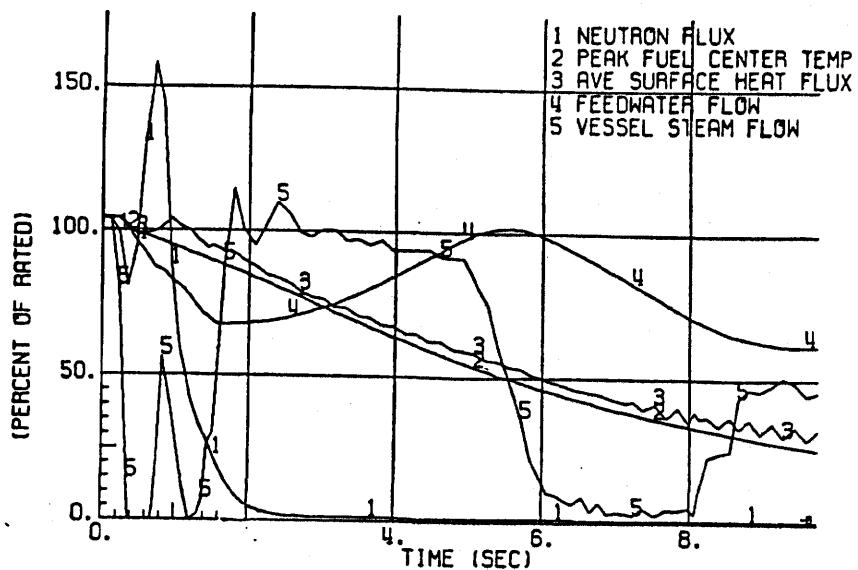

(Rev. 12 1/03)



PERRY NUCLEAR POWER PLANT

Generator Load Rejection
W/O Bypass 3729 MWt Core Power
73.6% Flow

Figure 15E.3-2 (Sheet 1 of 2)

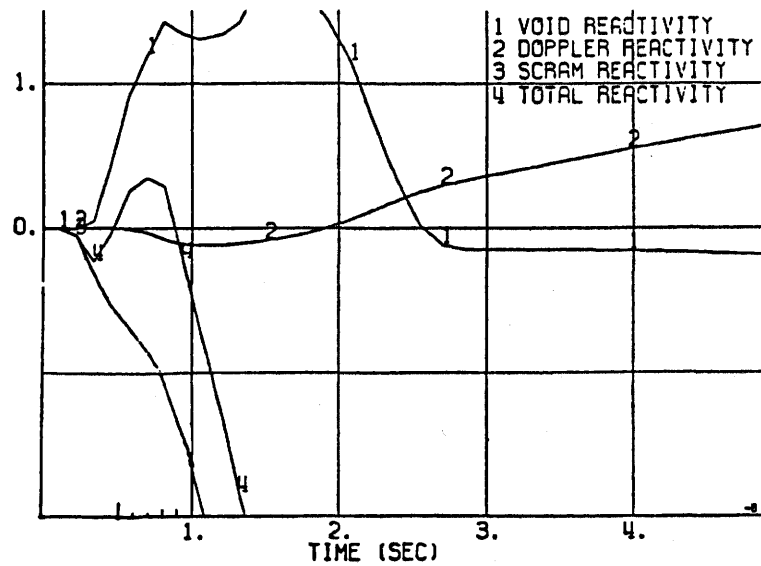
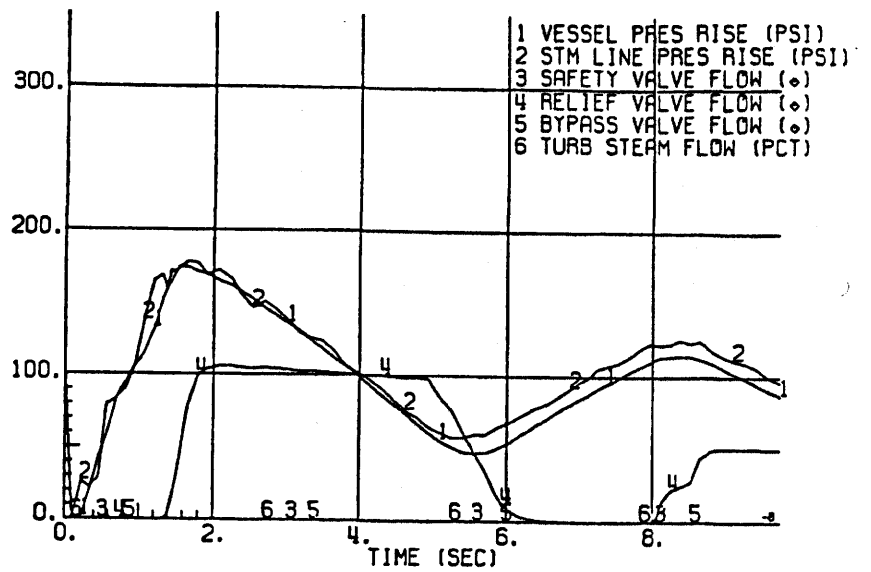

(Rev. 12 1/03)



PERRY NUCLEAR POWER PLANT

Generator Load Rejection
 W/O Bypass 3729 MWt Core Power
 73.6% Flow

Figure 15E.3-2 (Sheet 2 of 2)

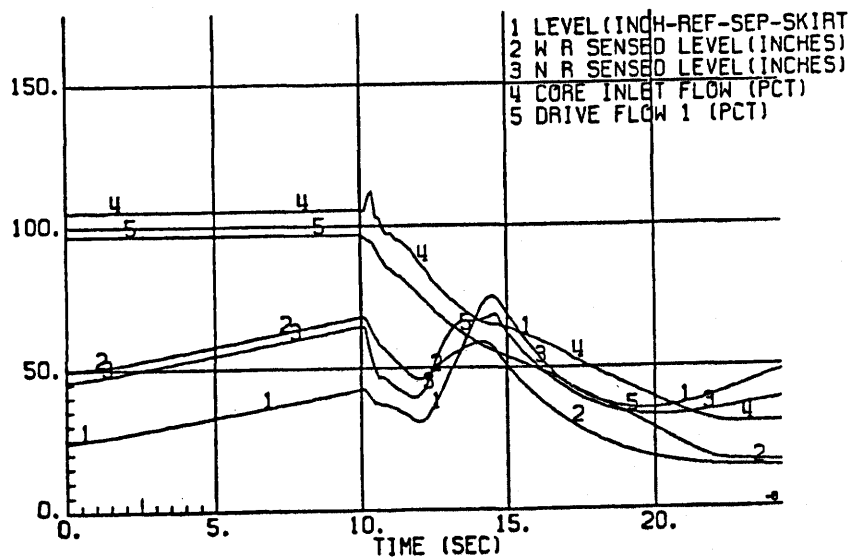
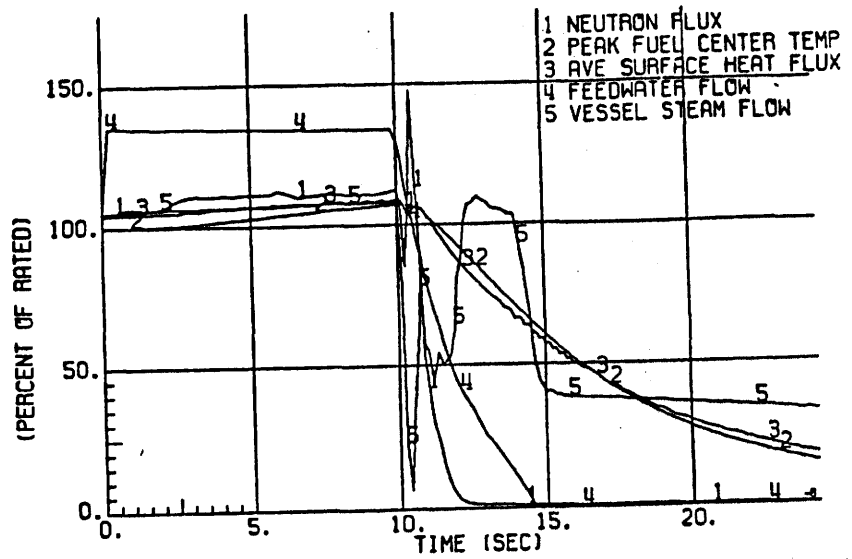

(Rev. 12 1/03)



PERRY NUCLEAR POWER PLANT

Feedwater Controller Failure
3729 MWt Core Power 105% Flow

Figure 15E.3-3 (Sheet 1 of 2)

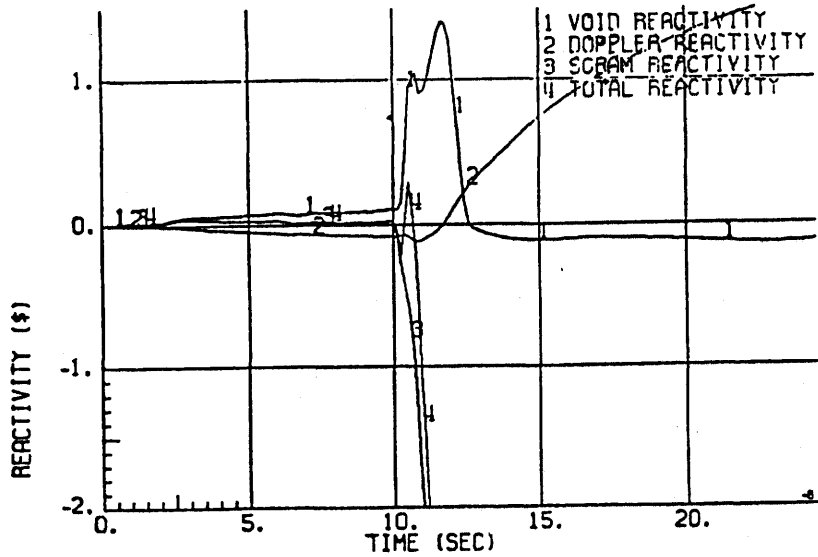
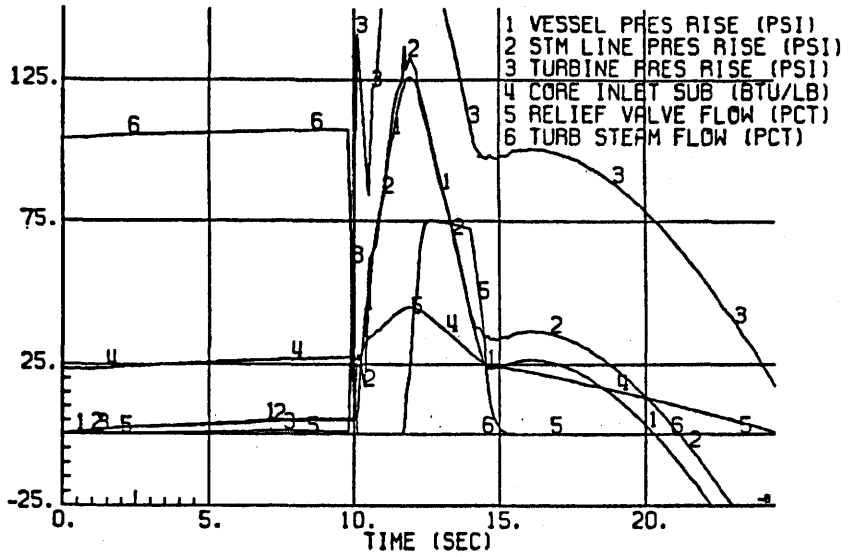

(Rev. 12 1/03)



PERRY NUCLEAR POWER PLANT

Feedwater Controller Failure
 3729 MWt Core Power 105% Flow

Figure 15E.3-3 (Sheet 2 of 2)

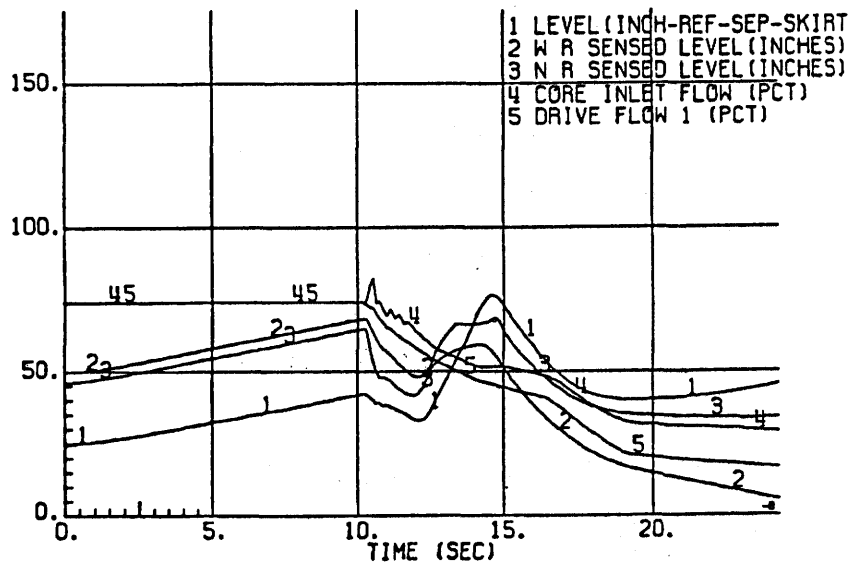
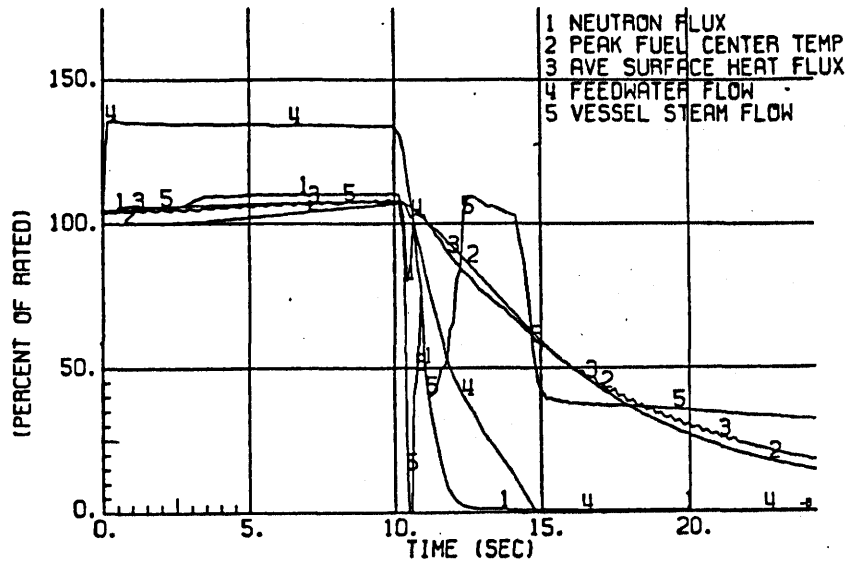

(Rev. 12 1/03)



PERRY NUCLEAR POWER PLANT

Feedwater Controller Failure
3729 MWt Core Power 73.6% Flow

Figure 15E.3-4 (Sheet 1 of 2)

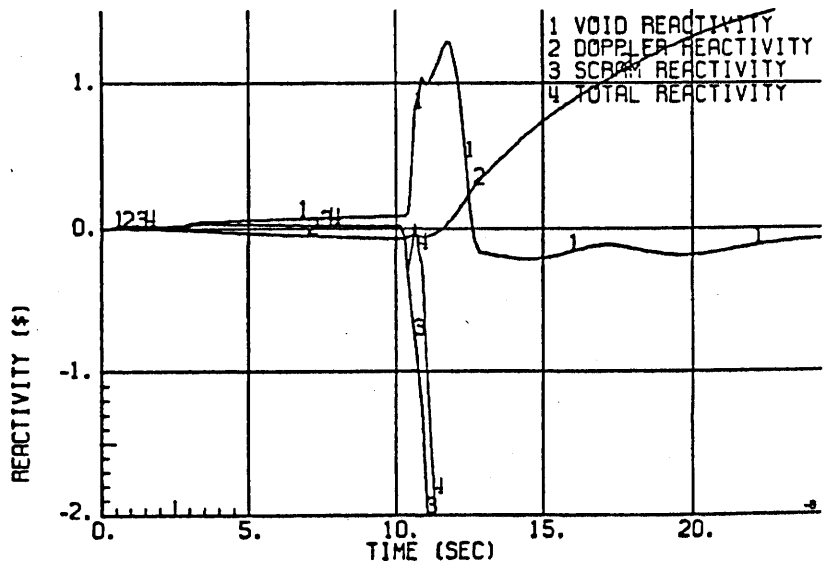
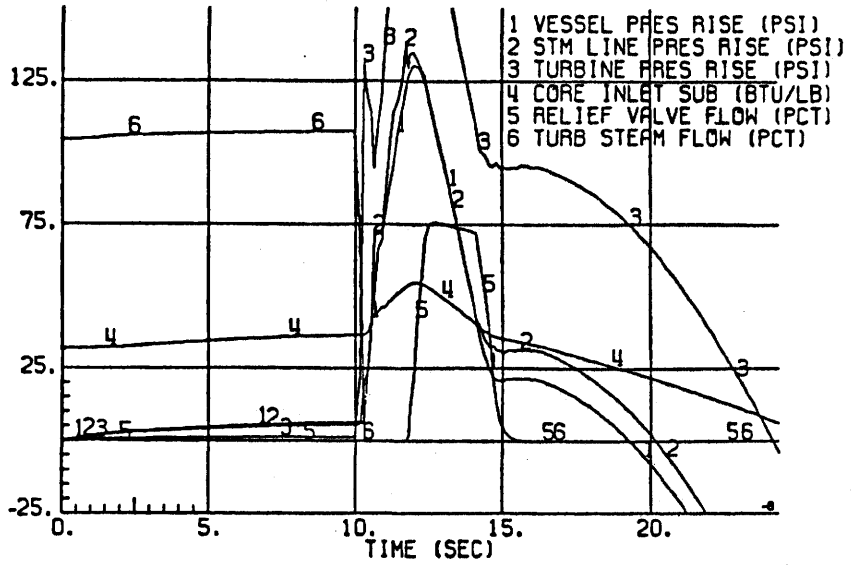

(Rev. 12 1/03)



PERRY NUCLEAR POWER PLANT

Feedwater Controller Failure
 3729 MWt Core Power 73.6% Flow

Figure 15E.3-4 (Sheet 2 of 2)

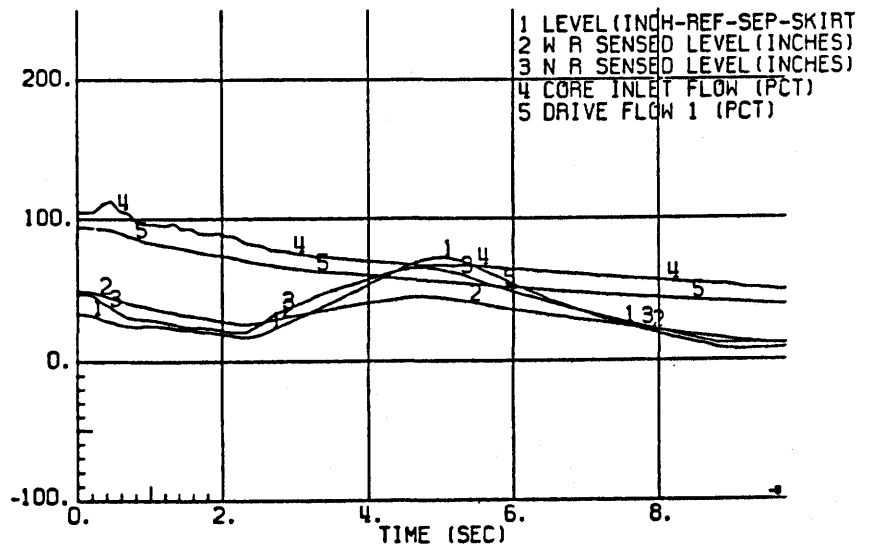
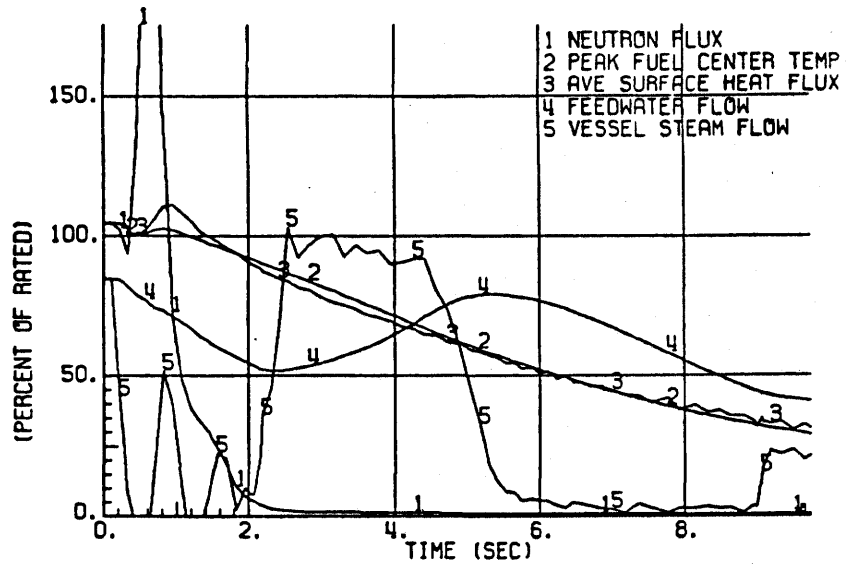

(Rev. 12 1/03)



PERRY NUCLEAR POWER PLANT

Generator Load Rejection
W/O Bypass 104.2% Power
105% Flow 250°F FWT

Figure 15E.11-1 (Sheet 1 of 2)

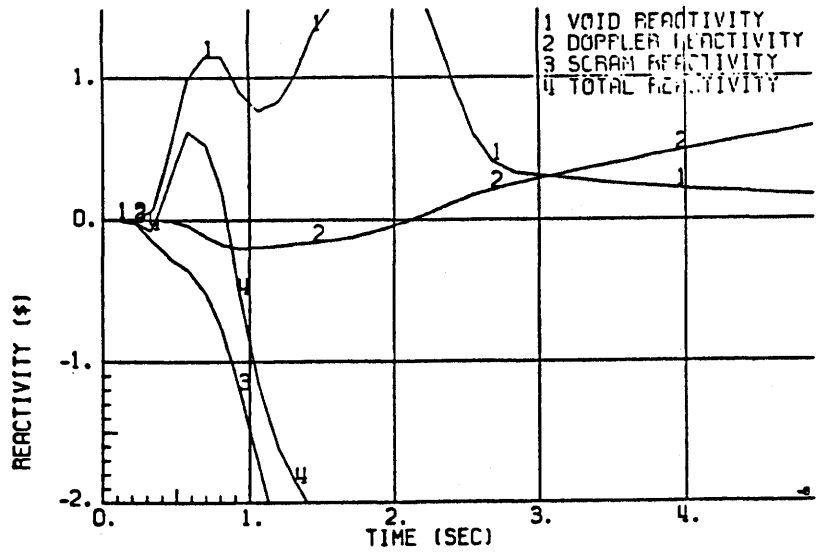
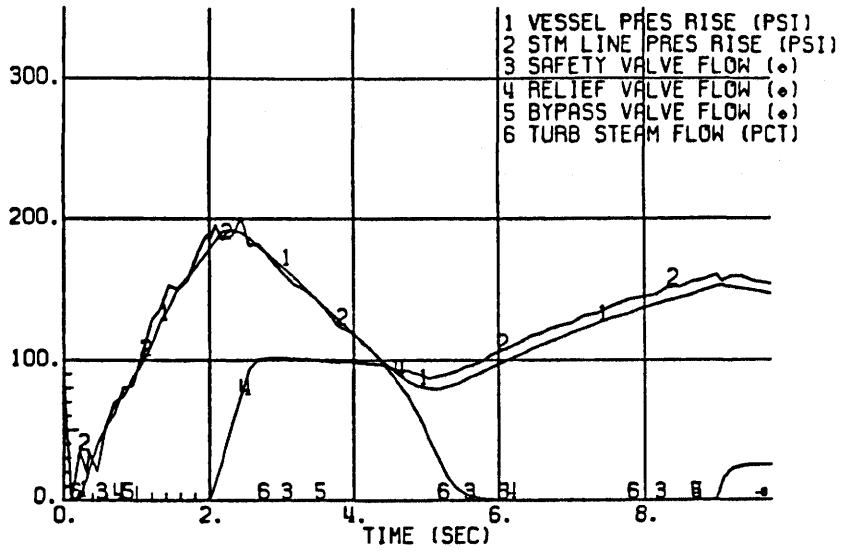

(Rev. 12 1/03)



PERRY NUCLEAR POWER PLANT

Generator Load Rejection
 W/O Bypass 104.2% Power
 105% Flow 250°F FWT

Figure 15E.11-1 (Sheet 2 of 2)

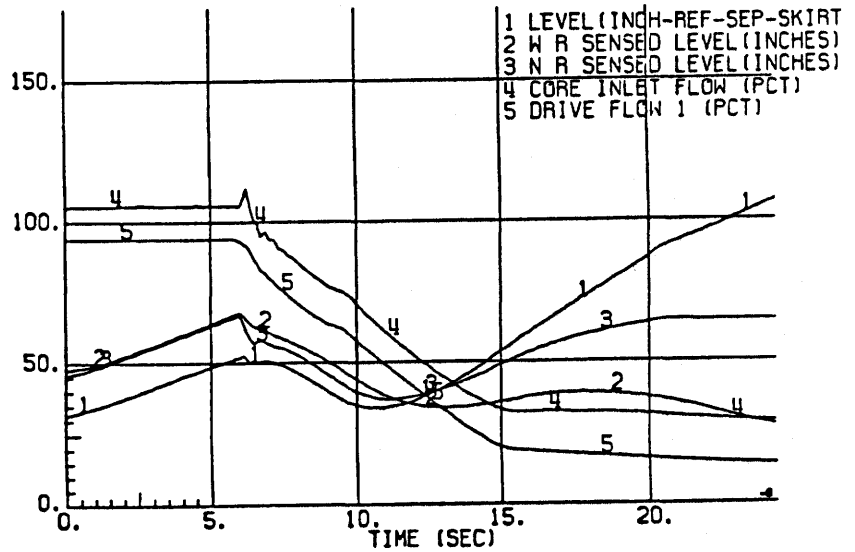
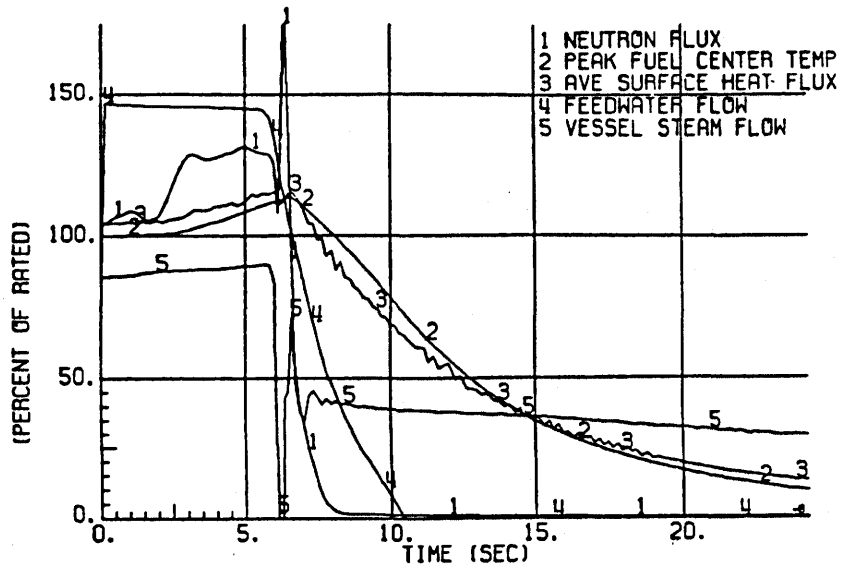

(Rev. 12 1/03)



PERRY NUCLEAR POWER PLANT

Feedwater Controller Failure
104.2% Power 105% Flow
250°F FWT

Figure 15E.11-2 (Sheet 1 of 2)

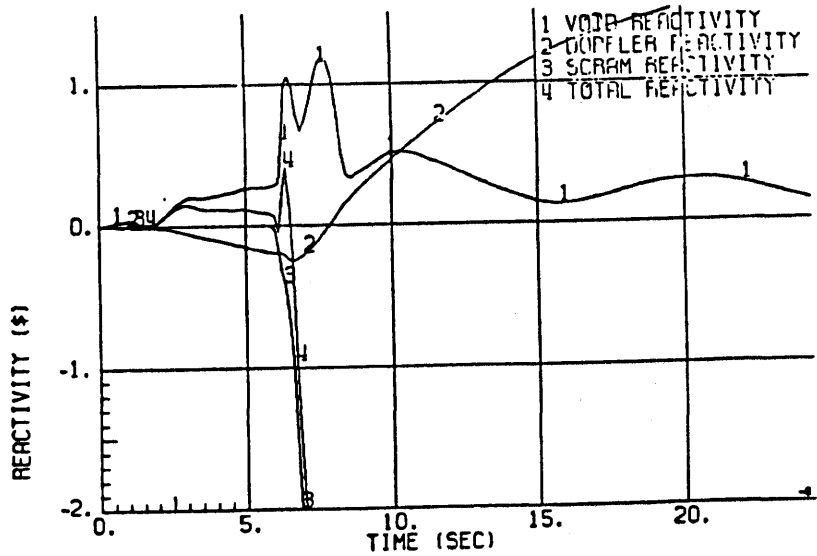
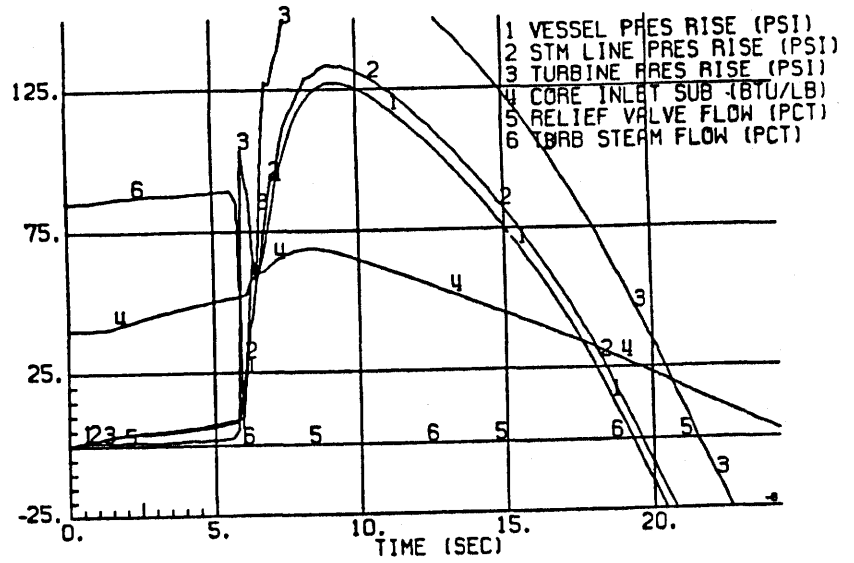

(Rev. 12 1/03)



PERRY NUCLEAR POWER PLANT

Feedwater Controller Failure
 104.2% Power 105% Flow
 250°F FWT

Figure 15E.11-2 (Sheet 2 of 2)

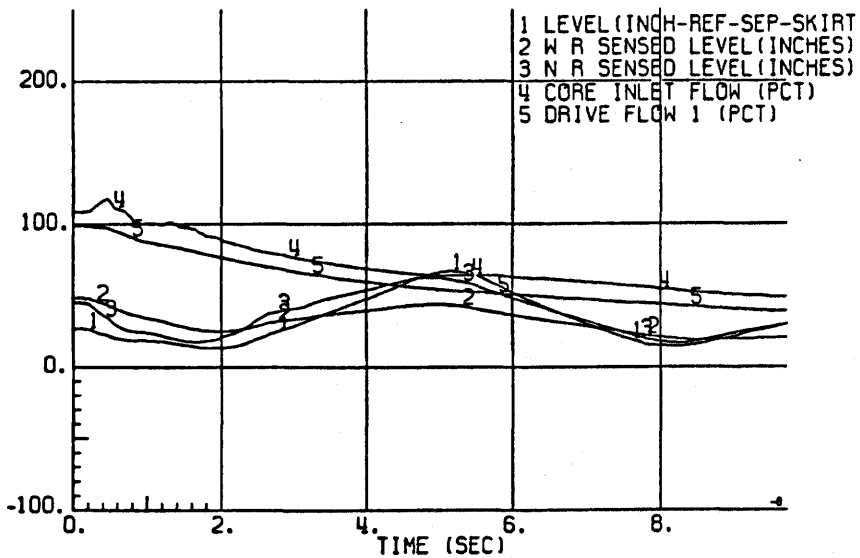
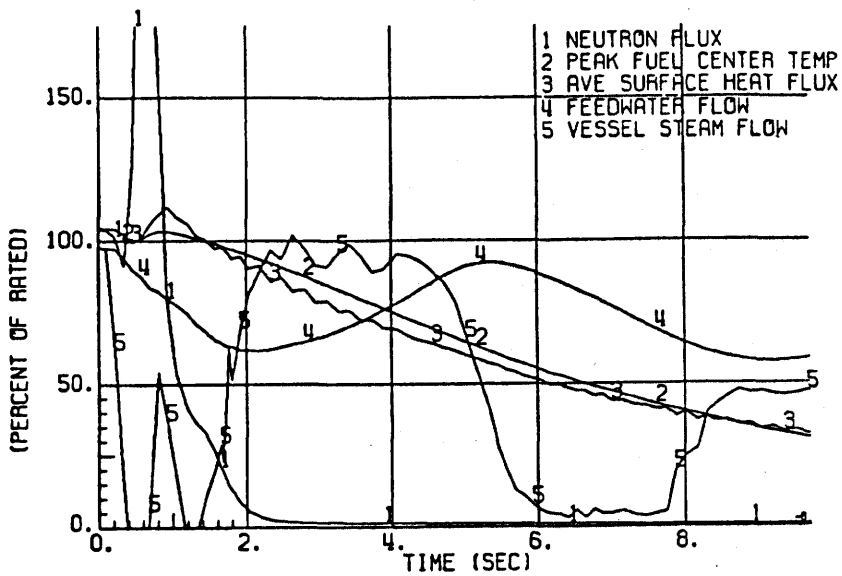

(Rev. 12 1/03)



PERRY NUCLEAR POWER PLANT

Generator Load Rejection
 W/O Bypass 104.2% Power 108.7% Flow
 370°F FWT

Figure 15E.11-3 (Sheet 1 of 2)

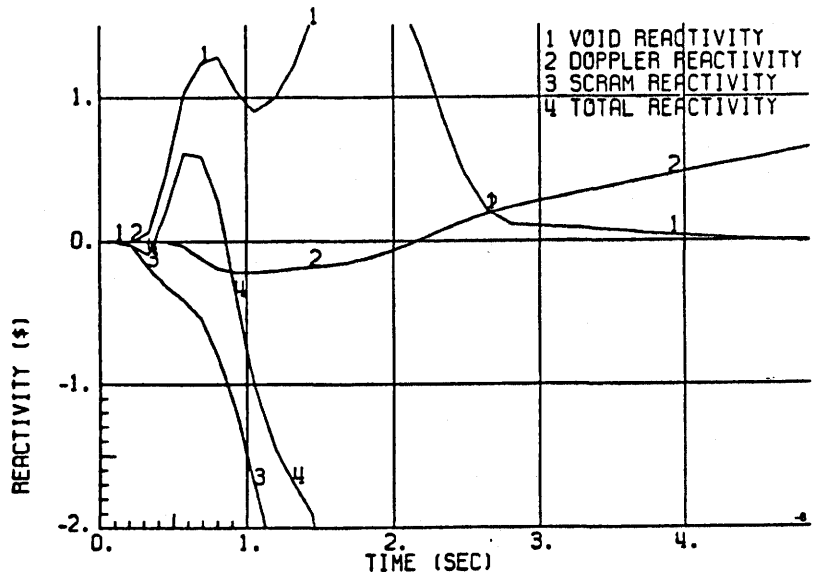
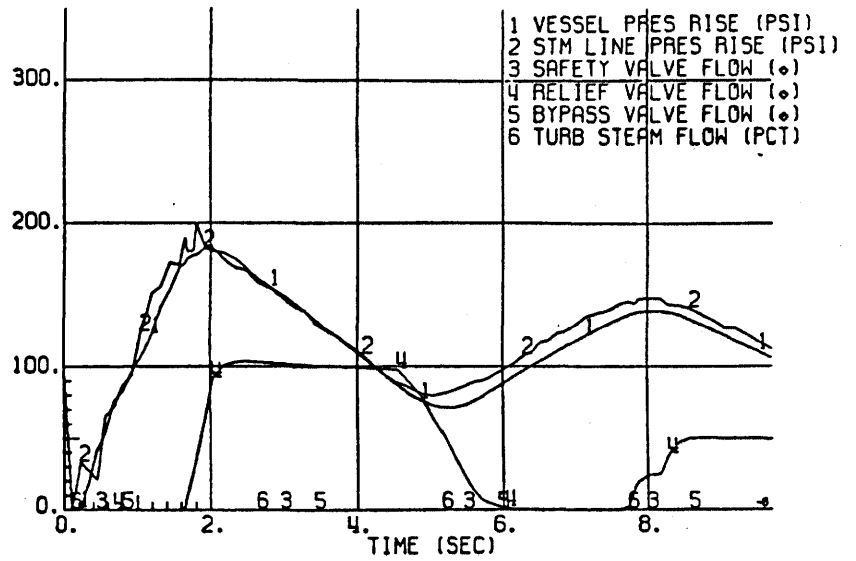

(Rev. 12 1/03)



PERRY NUCLEAR POWER PLANT

Generator Load Rejection
 W/O Bypass 104.2% Power
 108.7% Flow 370°F FWT

Figure 15E.11-3 (Sheet 2 of 2)

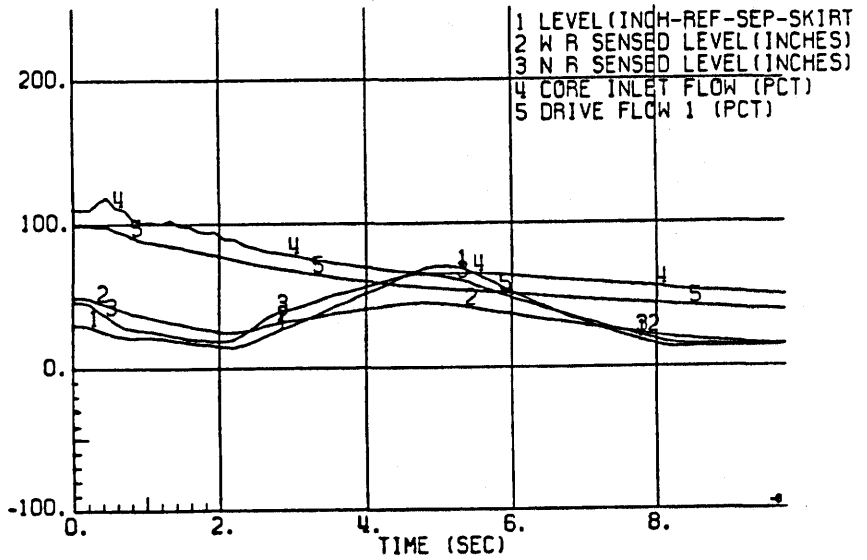
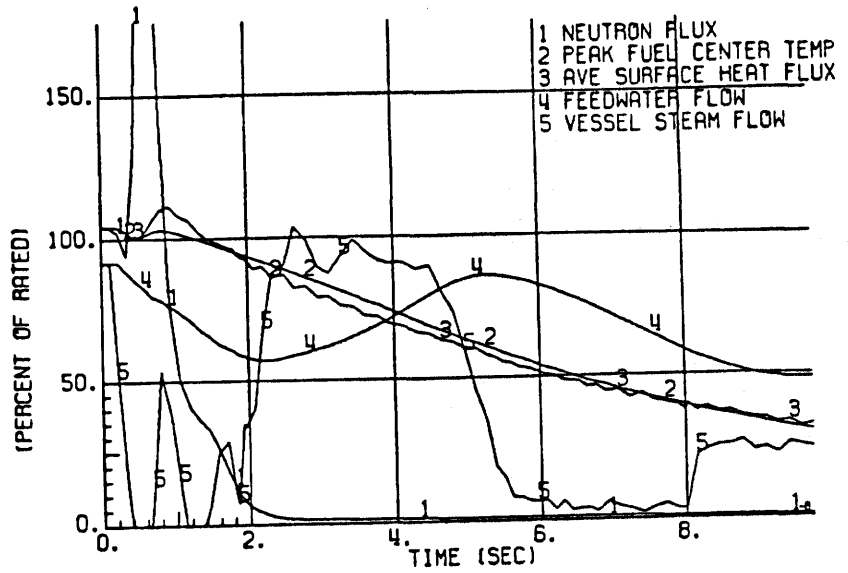

(Rev. 12 1/03)



PERRY NUCLEAR POWER PLANT

Generator Load Rejection
W/O Bypass 104.2% Power
110% Flow 320°F FWT

Figure 15E.11-4 (Sheet 1 of 2)

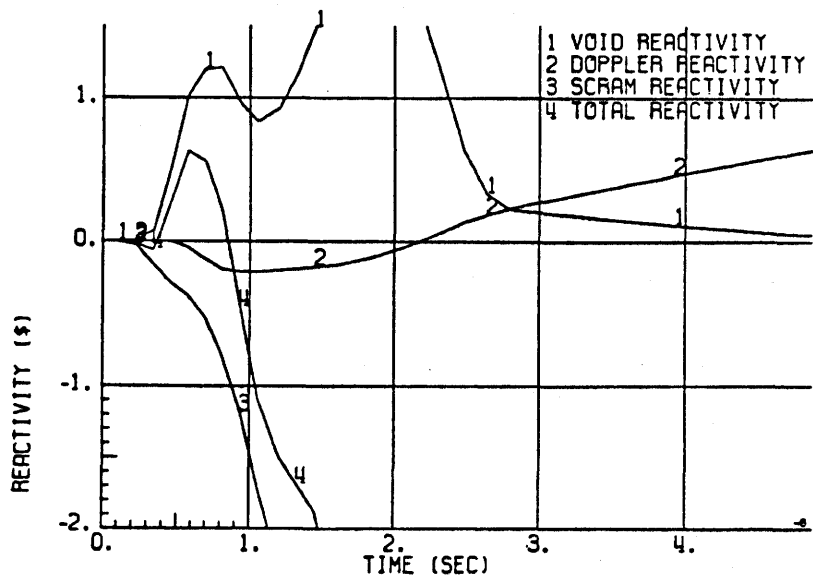
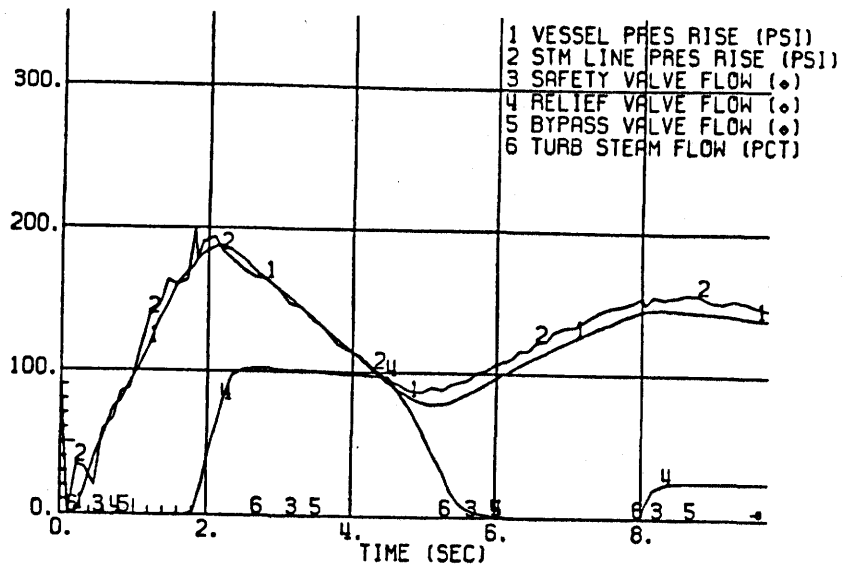

(Rev. 12 1/03)



PERRY NUCLEAR POWER PLANT

Generator Load Rejection
 W/O Bypass 104.2% Power
 110% Flow 320°F FWT

Figure 15E.11-4 (Sheet 2 of 2)

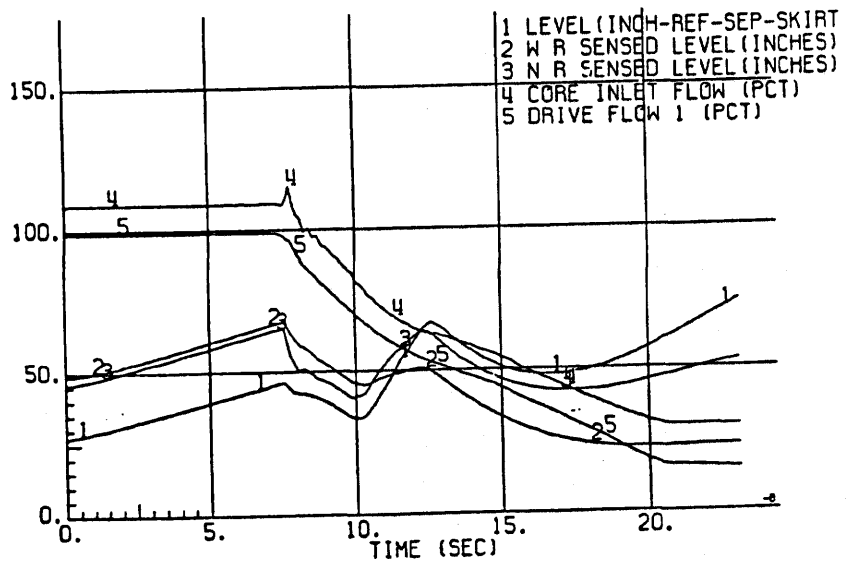
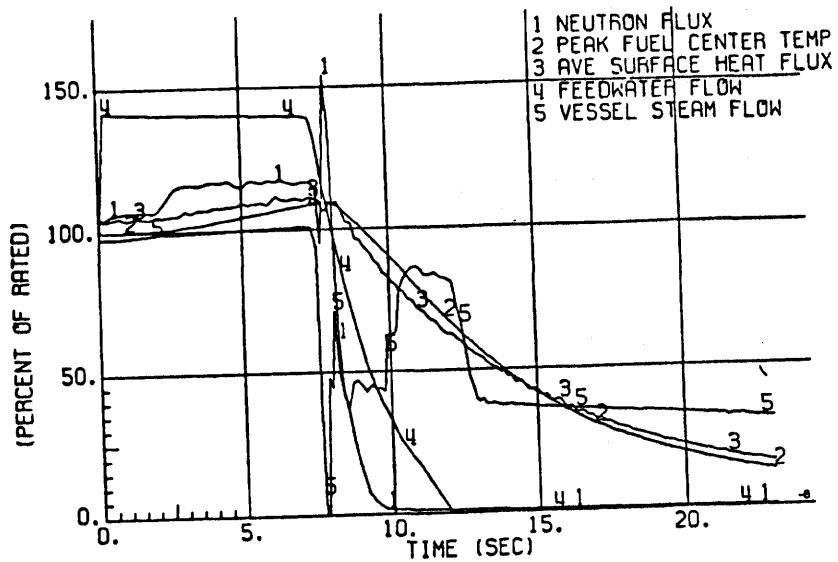

(Rev. 12 1/03)



PERRY NUCLEAR POWER PLANT

Feedwater Controller Failure
104.2% Power 108% Flow
370°F FWT

Figure 15E.11-5 (Sheet 1 of 2)

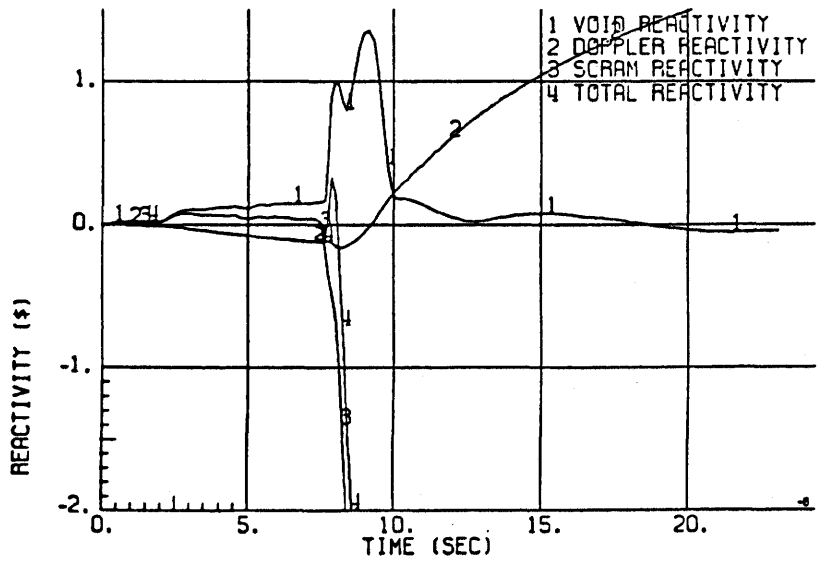
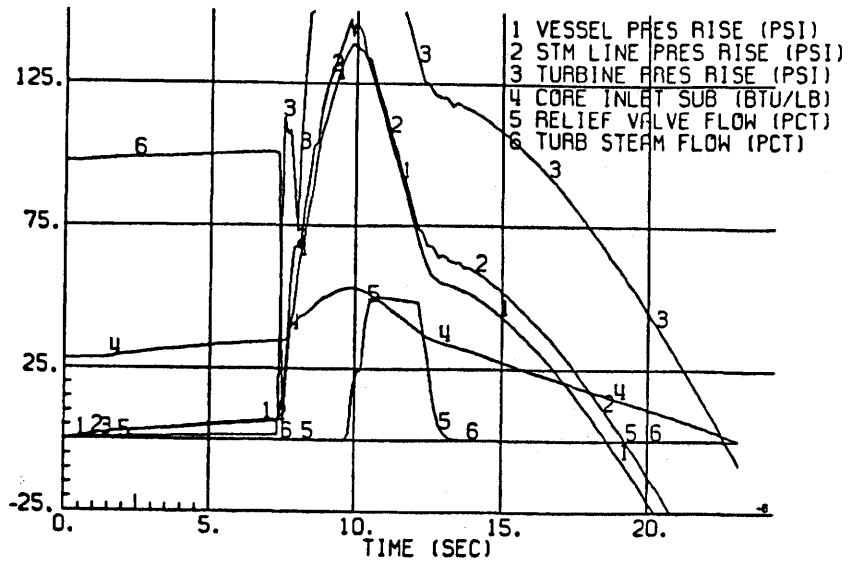

(Rev. 12 1/03)



PERRY NUCLEAR POWER PLANT

Feedwater Controller Failure
 104.2% Power 108% Flow
 370°F FWT

Figure 15E.11-5 (Sheet 2 of 2)

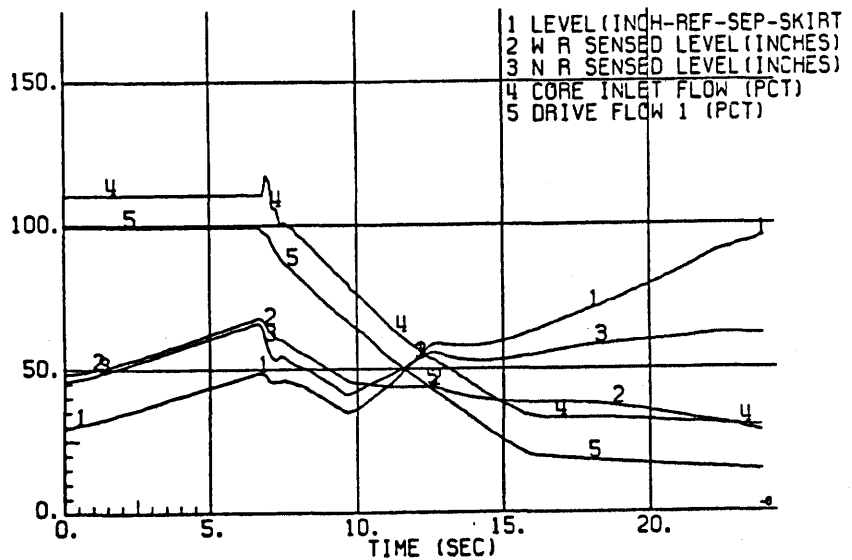
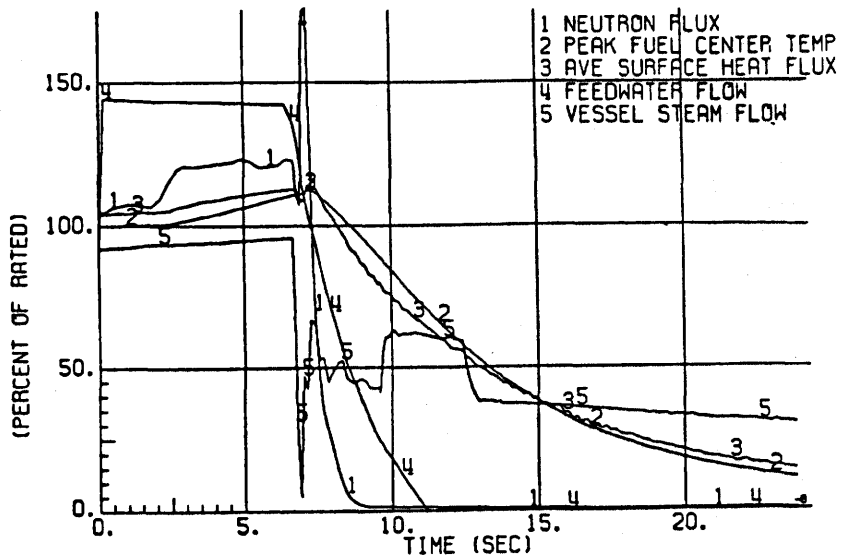

(Rev. 12 1/03)



PERRY NUCLEAR POWER PLANT

Feedwater Controller Failure
104.2% Power 110% Flow
320°F FWT

Figure 15E.11-6 (Sheet 1 of 2)

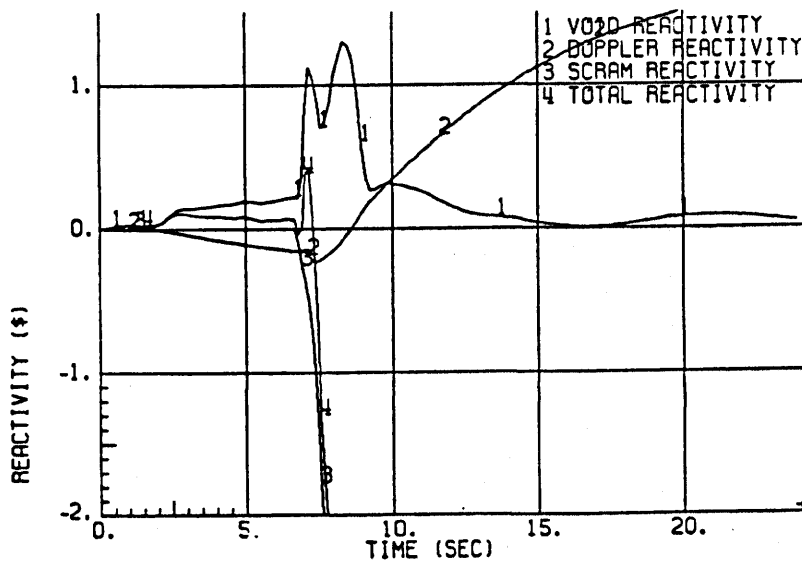
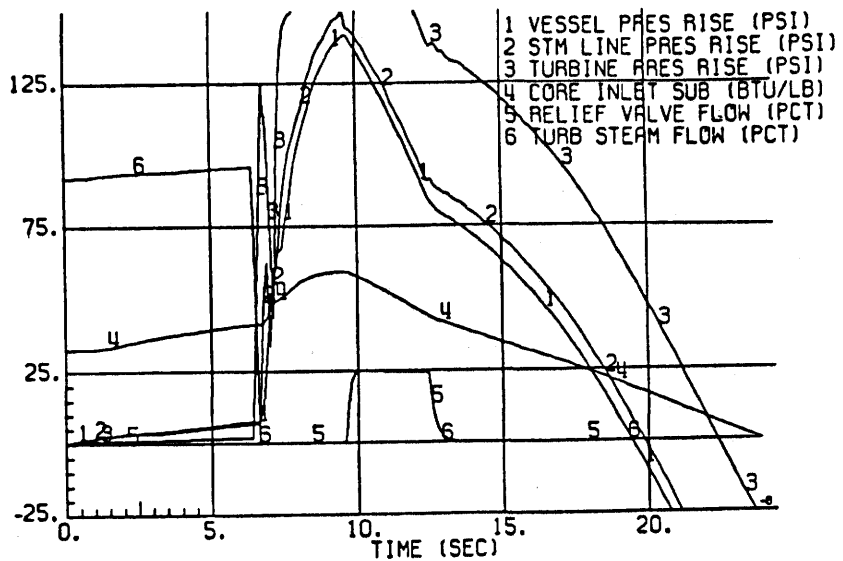

(Rev. 12 1/03)



PERRY NUCLEAR POWER PLANT

Feedwater Controller Failure
 104.2% Power 110% Flow
 320°F FWT

Figure 15E.11-6 (Sheet 2 of 2)

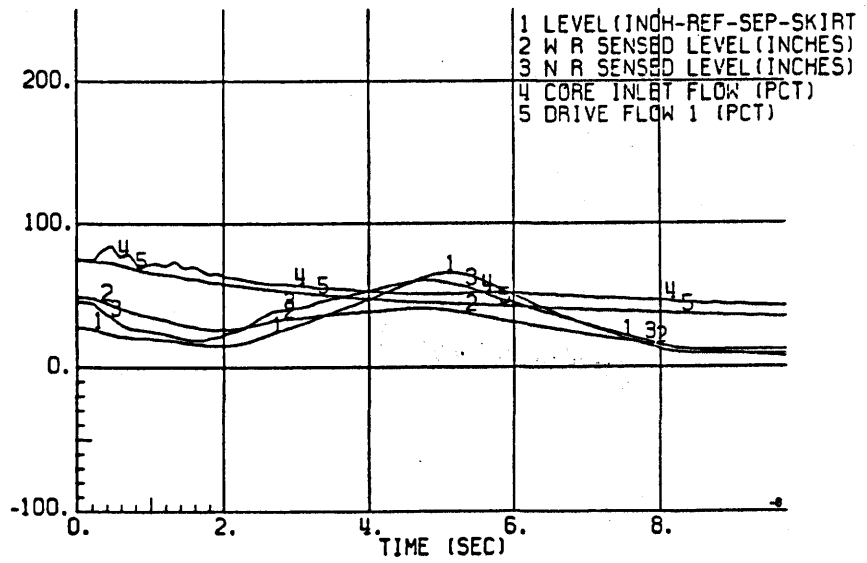
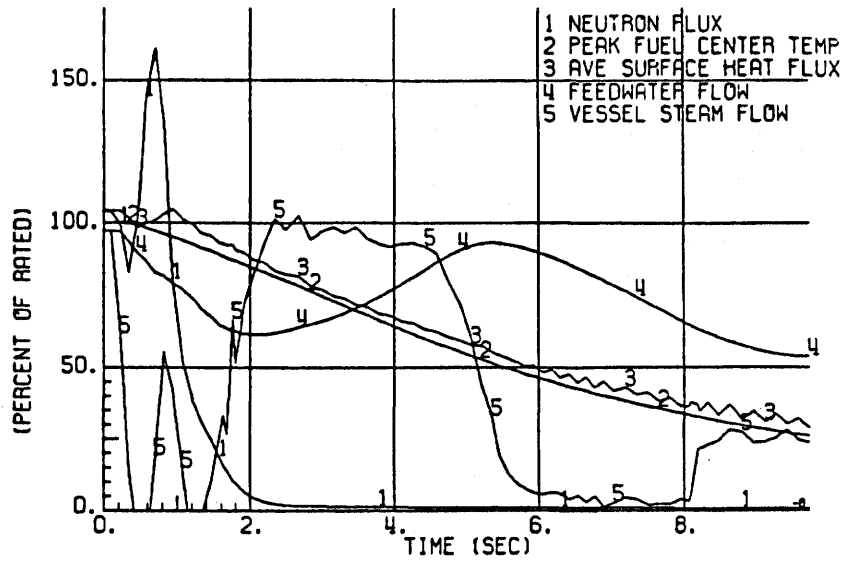

(Rev. 12 1/03)



PERRY NUCLEAR POWER PLANT

Generator Load Rejection
W/O Bypass 104.2% Power
74.8% Flow 370°F FWT

Figure 15E.11-7 (Sheet 1 of 2)

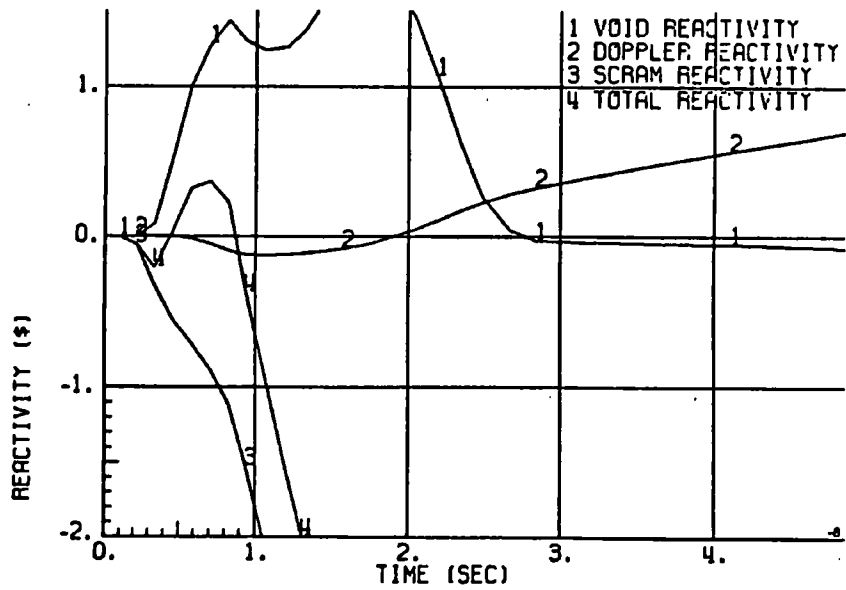
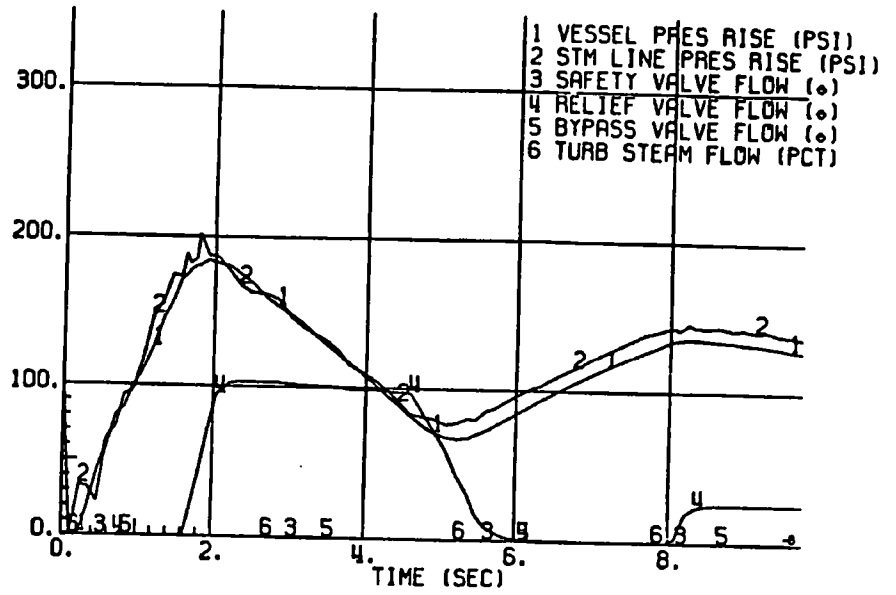

(Rev. 12 1/03)



PERRY NUCLEAR POWER PLANT

Generator Load Rejection
 W/O Bypass 104.2% Power
 74.8% Flow 370°F FWT

Figure 15E.11-7 (Sheet 2 of 2)

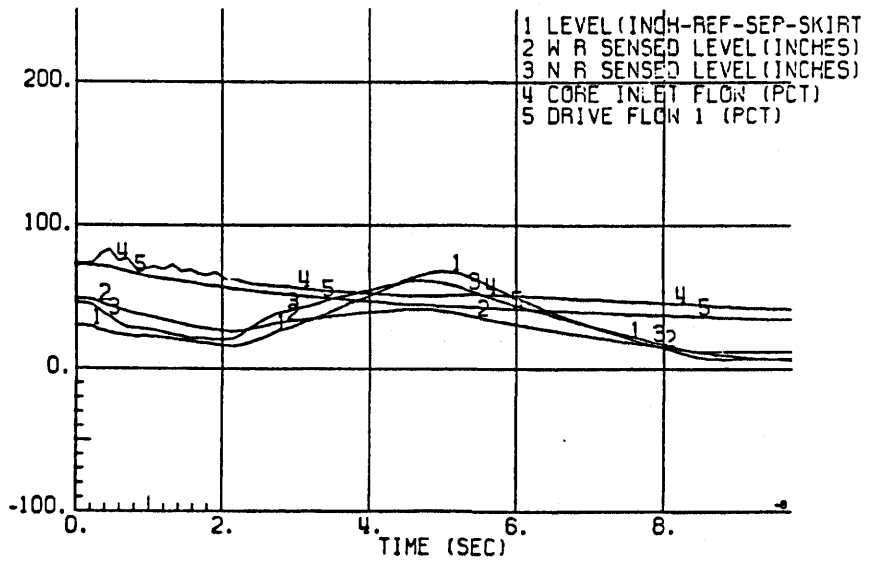
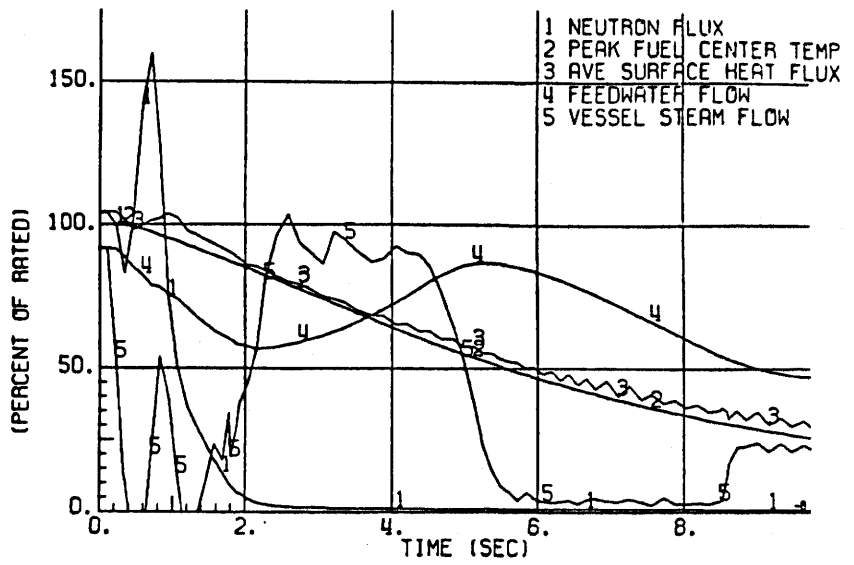

(Rev. 12 1/03)



PERRY NUCLEAR POWER PLANT

Generator Load Rejection
 W/O Bypass 104.2% Power
 73.7% Flow 320°F FWT

Figure 15E.11-8 (Sheet 1 of 2)

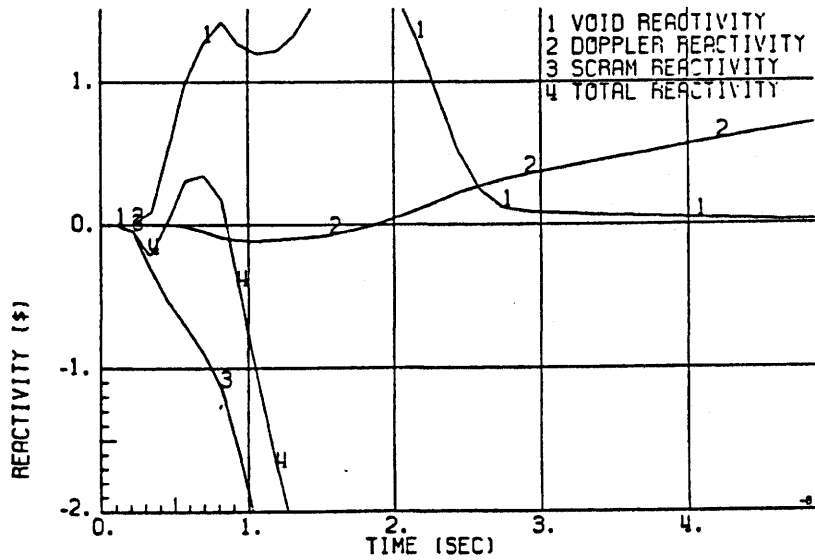
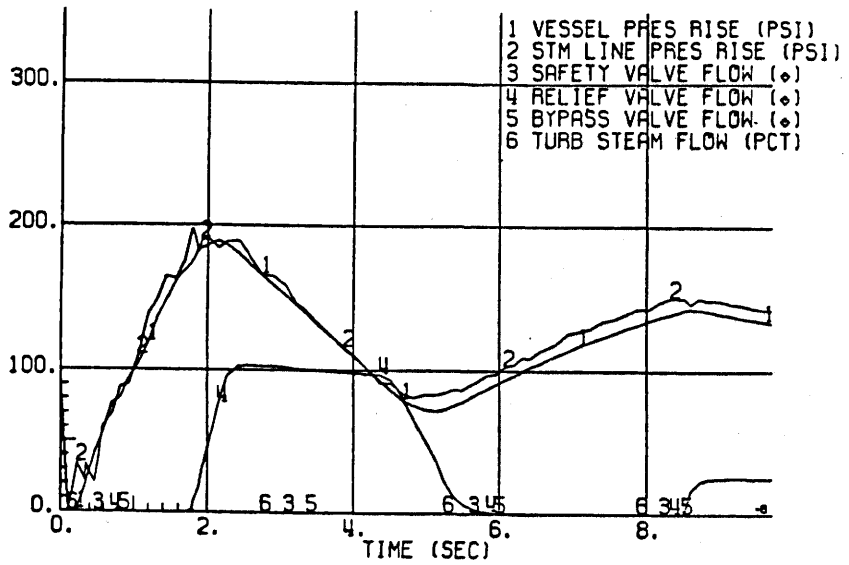

(Rev. 12 1/03)



PERRY NUCLEAR POWER PLANT

Generator Load Rejection
 W/O Bypass 104.2% Power
 73.7% Flow 320°F FWT

Figure 15E.11-8 (Sheet 2 of 2)

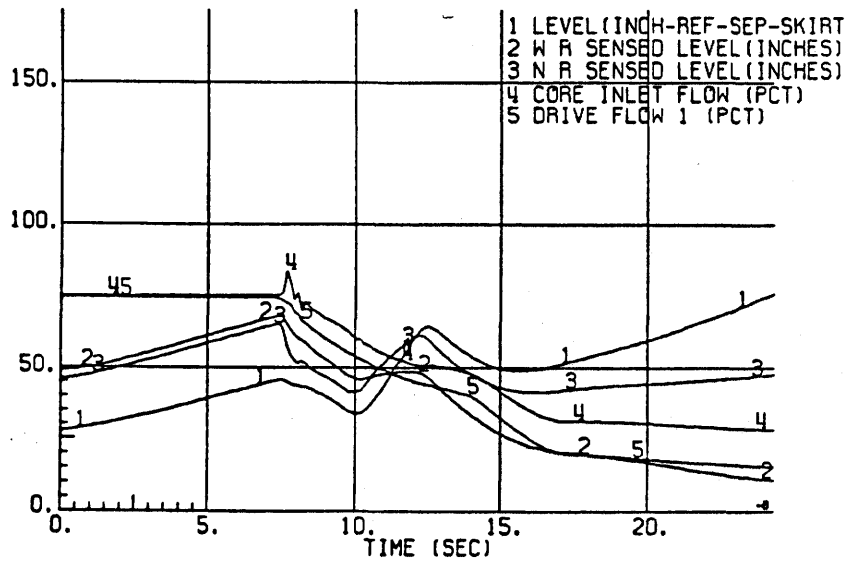
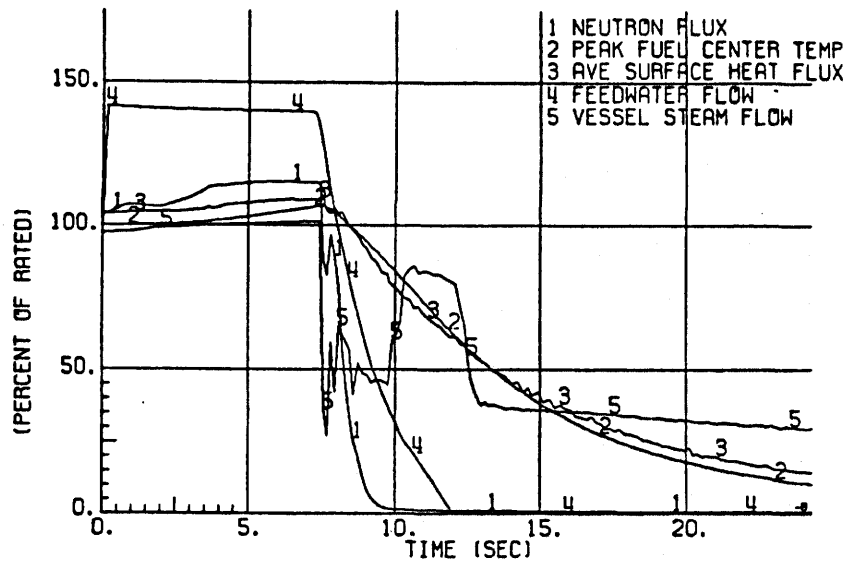

(Rev. 12 1/03)



PERRY NUCLEAR POWER PLANT

Feedwater Controller Failure
104.2% Power 74.8% Flow
370°F FWT

Figure 15E.11-9 (Sheet 1 of 2)

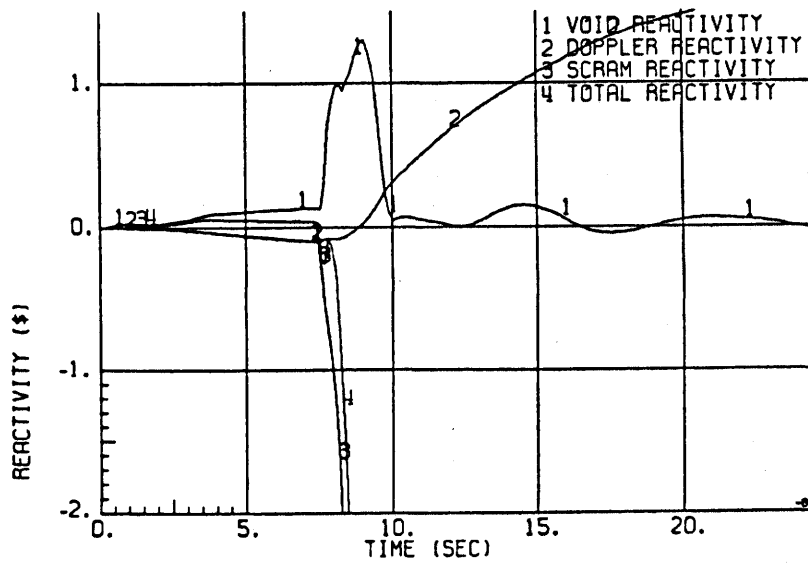
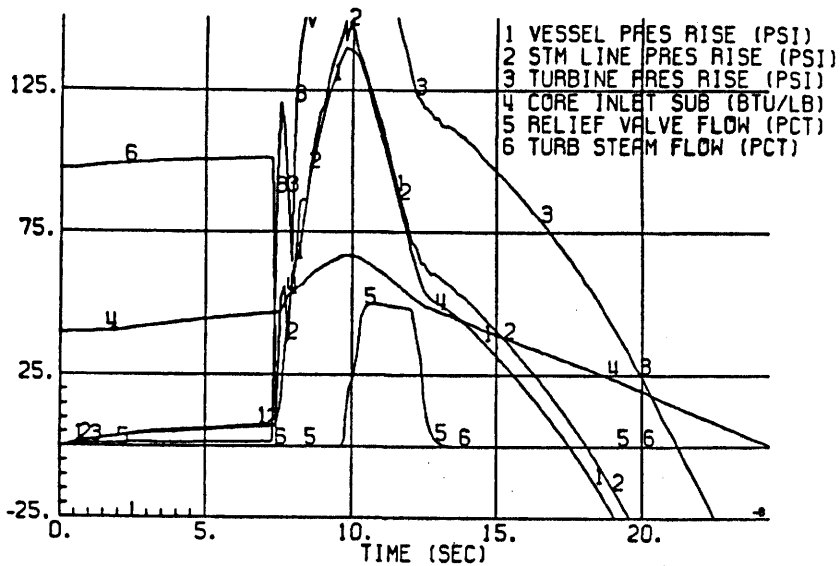

(Rev. 12 1/03)



PERRY NUCLEAR POWER PLANT

Feedwater Controller Failure
 104.2% Power 74.8% Flow
 370°F FWT

Figure 15E.11-9 (Sheet 2 of 2)

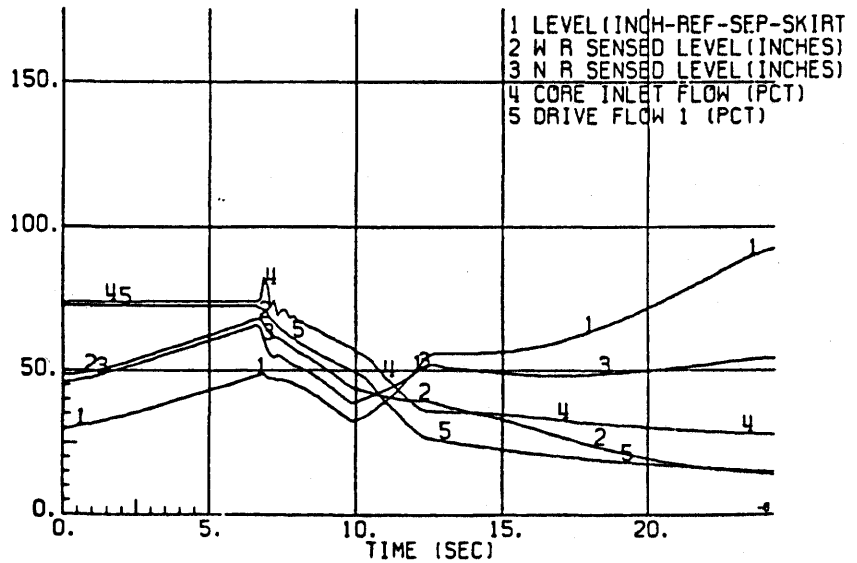
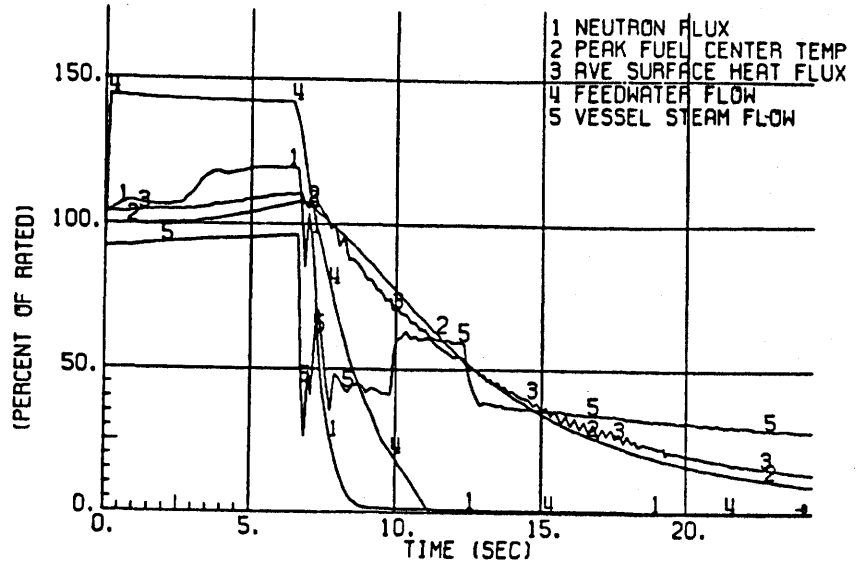

(Rev. 12 1/03)



PERRY NUCLEAR POWER PLANT

Feedwater Controller Failure
104.2% Power 73.7% Flow
320°F FWT

Figure 15E.11-10 (Sheet 1 of 2)

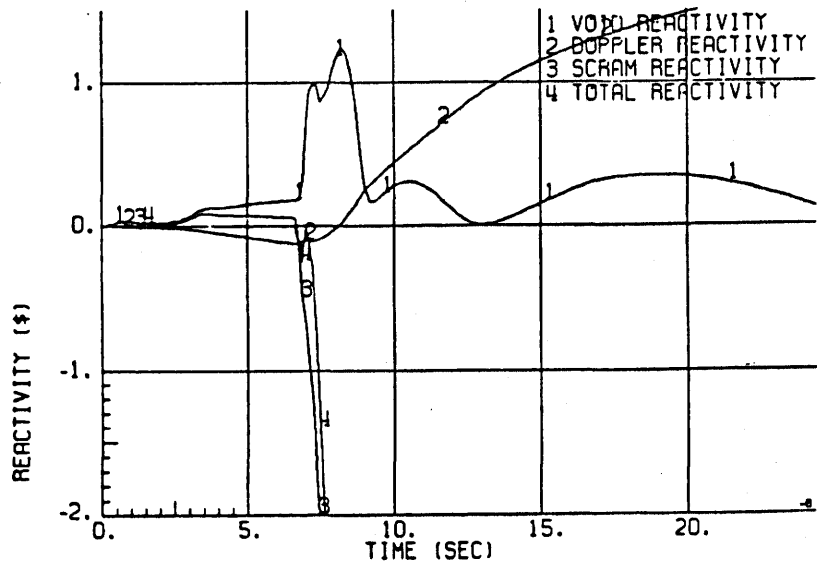
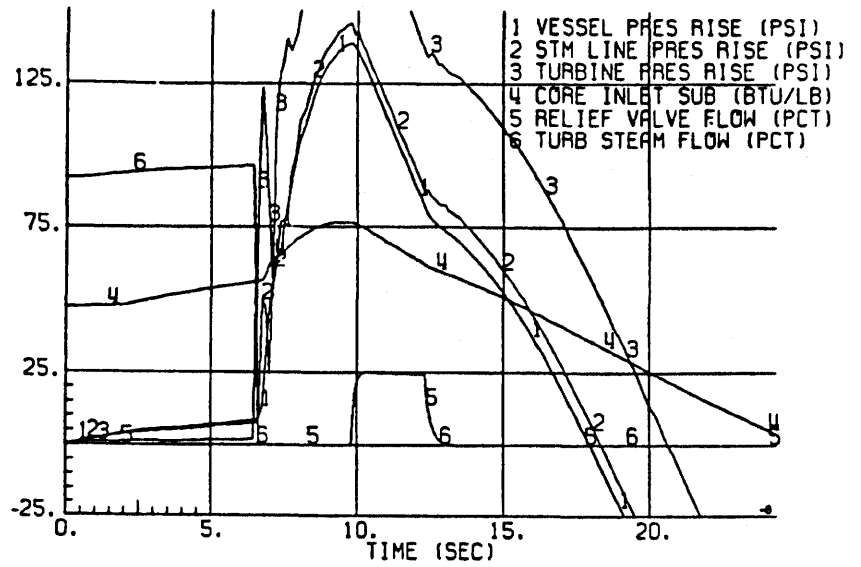

(Rev. 12 1/03)



PERRY NUCLEAR POWER PLANT

Feedwater Controller Failure
 104.2% Power 73.7% Flow
 320°F FWT

Figure 15E.11-10 (Sheet 2 of 2)

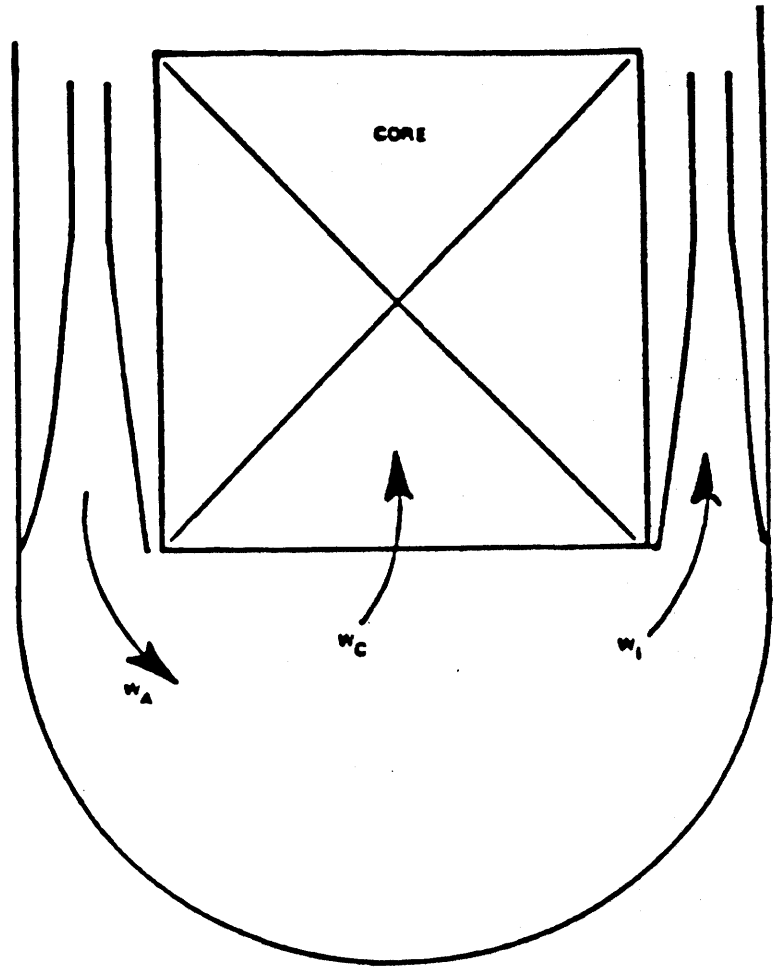

w_C = Total Core Flow
 w_A = Active Loop Flow
 w_I = Inactive Loop Flow

(Rev. 12 1/03)



PERRY NUCLEAR POWER PLANT

Illustration of Single
 Recirculation Loop
 Operation Flows

Figure 15F.2-1

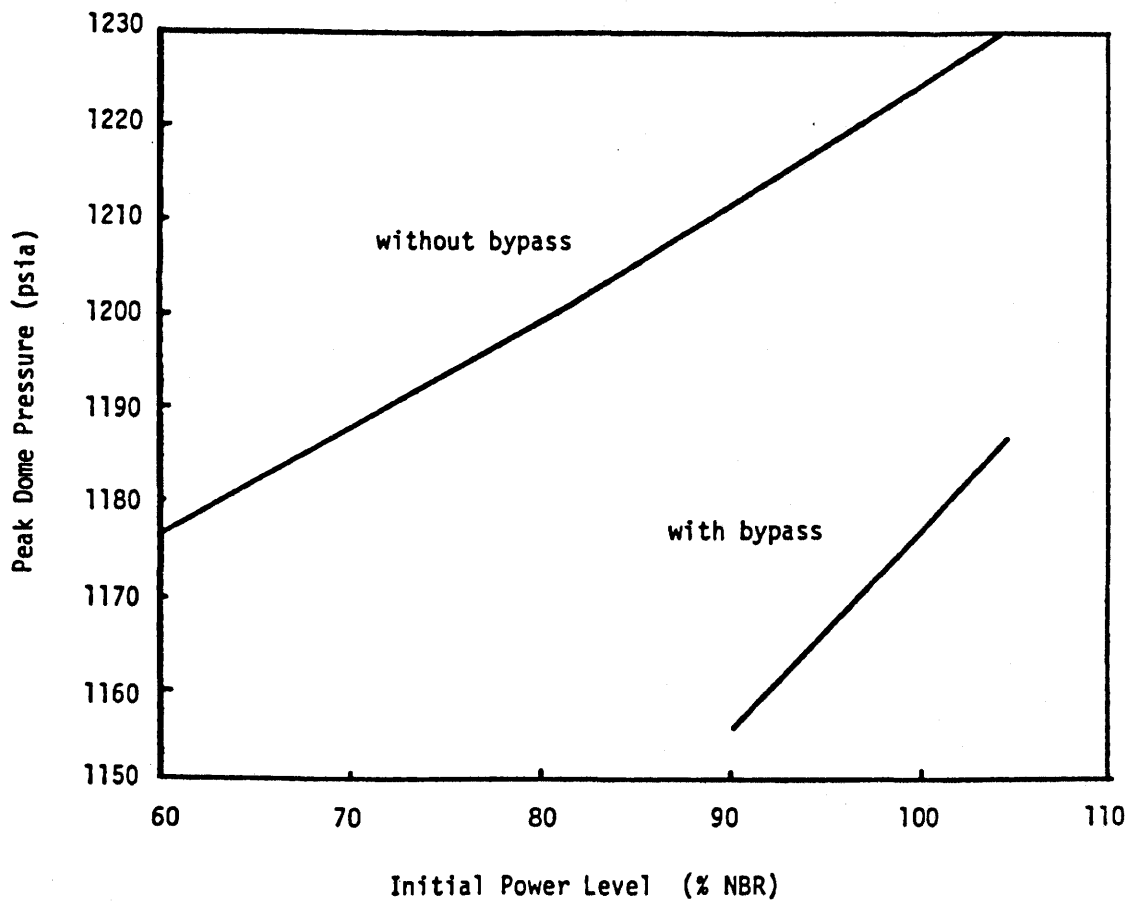

(Rev. 12 1/03)



PERRY NUCLEAR POWER PLANT

Peak Dome Pressure Versus
Initial Power Level,
Turbine Trip at EOEC

Figure 15F.3-1

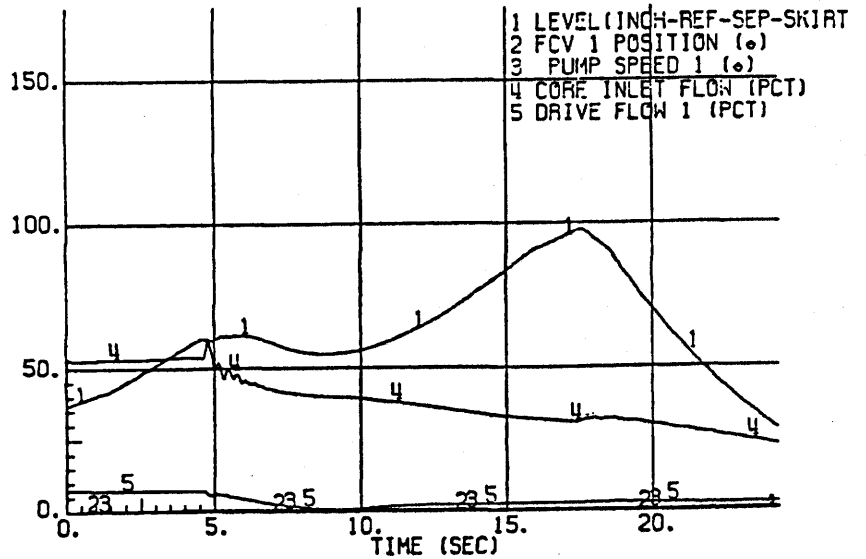
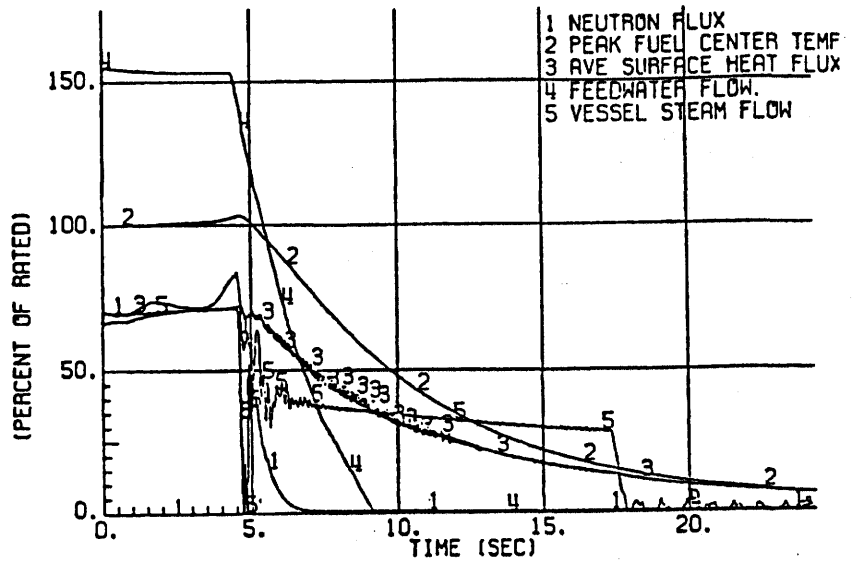

FWCF. MAX DEMA W/ HWL TRIPS

(Rev. 12 1/03)



PERRY NUCLEAR POWER PLANT

Feedwater Controller Failure -
Maximum Demand
Single Loop Operations

Figure 15F.3-2 (Sheet 1 of 2)

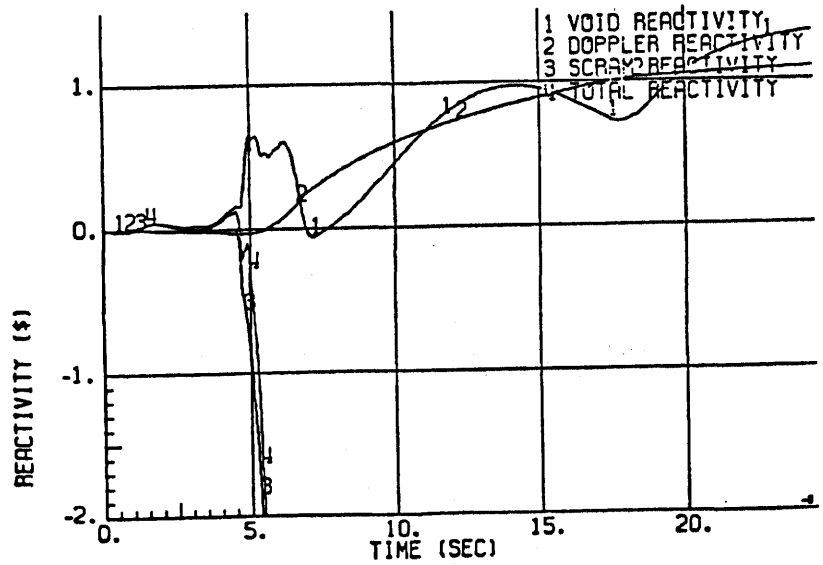
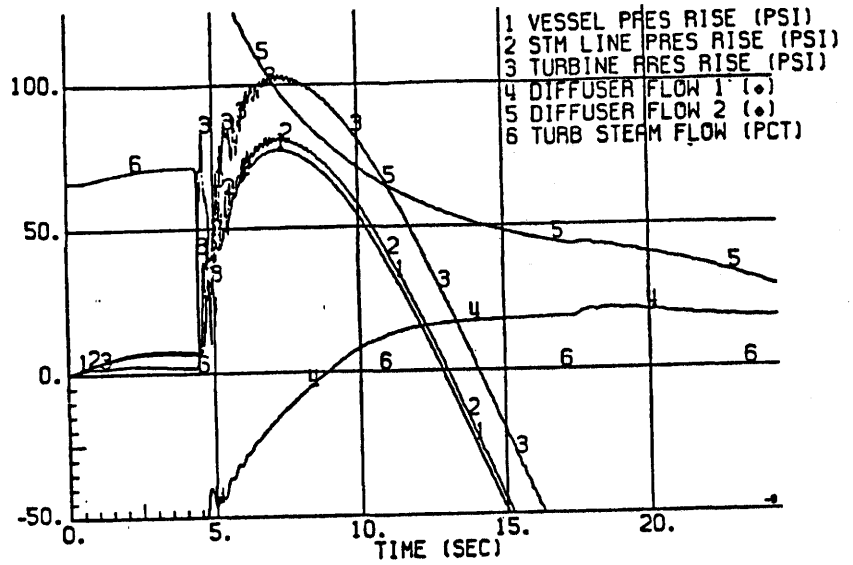

(Rev. 12 1/03)



PERRY NUCLEAR POWER PLANT

Feedwater Controller Failure -
 Maximum Demand
 Single Loop Operations

Figure 15F.3-2 (Sheet 2 of 2)

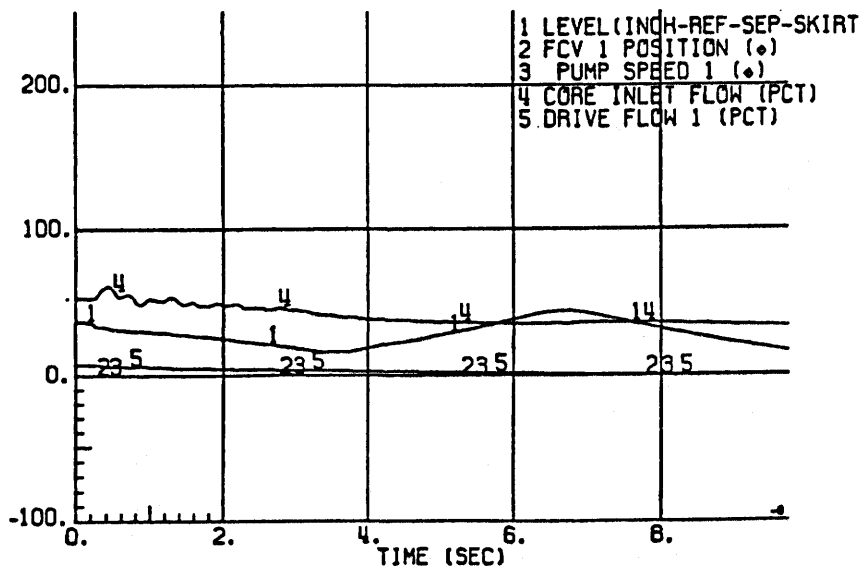
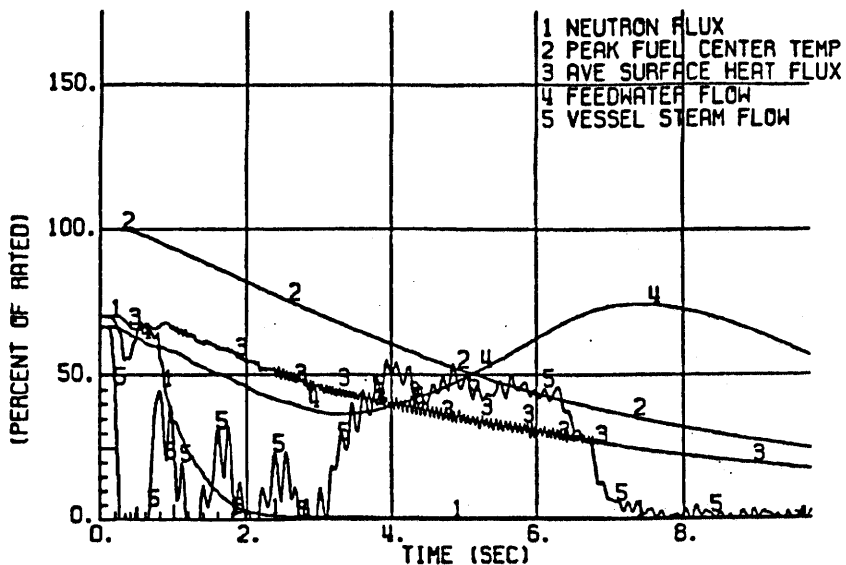

(Rev. 12 1/03)



PERRY NUCLEAR POWER PLANT

Generator Load Rejection,
W/O Bypass Single Loop
Operation

Figure 15F.3-3 (Sheet 1 of 2)

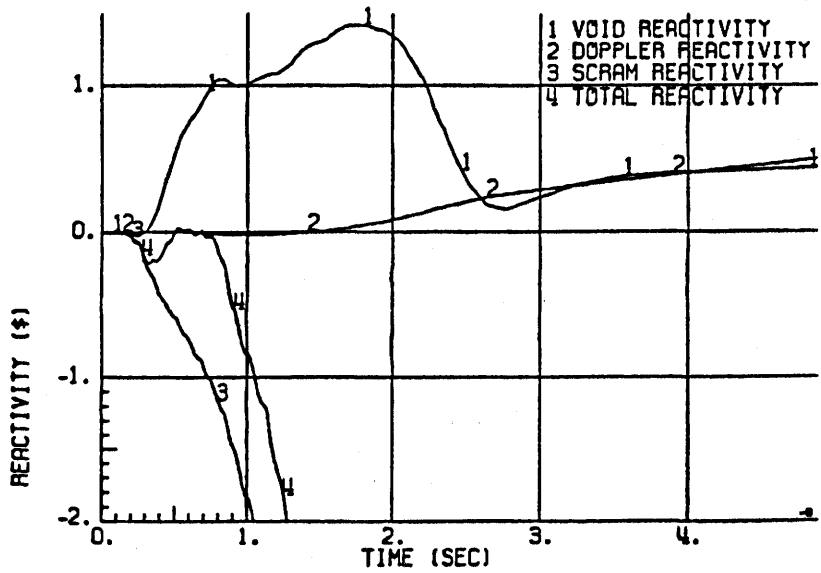
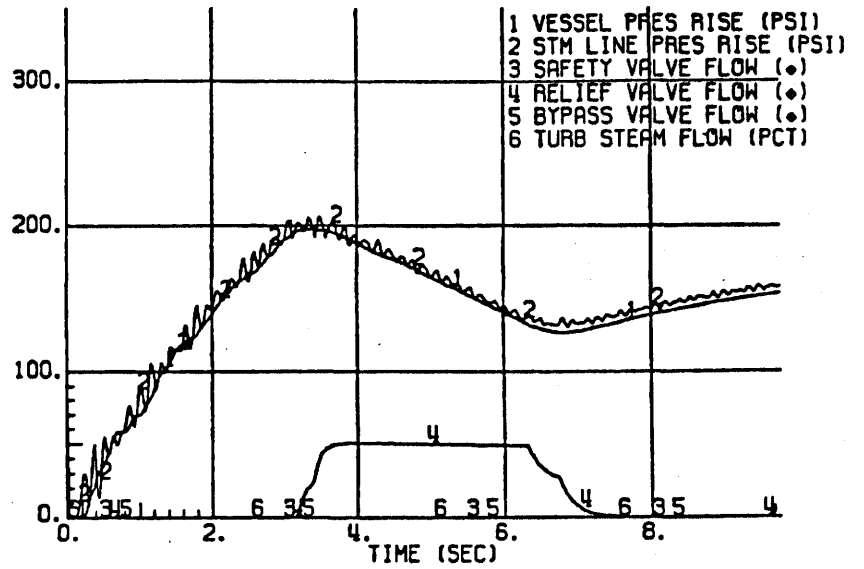

(Rev. 12 1/03)



PERRY NUCLEAR POWER PLANT

Generator Load Rejection,
 W/O Bypass
 Single Loop Operation

Figure 15F.3-3 (Sheet 2 of 2)