

OPERATING DATA  
SEE NOTES 6, 7

PSIG	LBS/HR	* F	REMARKS
1	966	4071689	542
2	959	186954	541 75XLOAD
3	959	180651	541 75XLOAD
4	959	107432	541 STARTUP
5	966	1612354	542 BYPASS
6	966	1209266	542 BYPASS
7	966	836	542
8	150	24377	370
9	959	53442	541 25XLOAD
10	959	30100	541 STARTUP
11	959	25213	541
12	164	94847	511
13	966	3889948	542

DESIGN DATA

#	NORMAL		UPSET		REMARKS
	PSIG	T	PSIG	T	
1	1250	575	1250	575	
4	180	400	180	400	
6	240	512	240	512	

REFERENCES:

- 302-0012-00000 REHEAT STEAM SYSTEM N11
- 302-0014-00000 REHEATER REHEATING STEAM SYSTEM N11
- 302-0121-00000 MAIN REHEAT EXTRACTION AND MISCELLANEOUS DRAINS N22
- 302-0123-00000 MAIN REHEAT EXTRACTION AND MISCELLANEOUS DRAINS N22
- 302-0124-00000 MAIN REHEAT EXTRACTION AND MISCELLANEOUS DRAINS N22
- 302-0125-00000 MAIN REHEAT EXTRACTION AND MISCELLANEOUS DRAINS N22
- 302-0131-00000 CONDENSER AIR REMOVAL SYSTEM N62
- 302-0141-00000 STEAM MAIN SYSTEM N33
- 302-0183-00000 TURBINE PLANT SAMPLING SYSTEM P33
- 302-0751-00000 OFF GAS SYSTEM N64
- 828E454 GE MED NUCLEAR STEAM SUPPLY SHUTOFF SYSTEM ELEMENTARY
- 199A9894 GE TURBINE INTERCONNECTION DIAGRAM
- 302-0021-00000 STEAM BYPASS AND PRESSURE REGULATION SYSTEM C65
- 302-0605-00000 NUCLEAR BOILER SYSTEM B21
- 802-0009-00000 REACTOR-TURBINE GENERATOR TRIP DIAGRAM
- 911-0005-00000 LUBE OIL AREA-TURBINE LAY-DOWN AND WATER TREATMENT
- 911-0005-00000 LUBE OIL AREA-TURBINE LAY-DOWN AND WATER TREATMENT BUILDING DRAINS P68

NOTES:

1. PRESSURE TAPS TO MEET ASME PTC6194 "STEAM TURBINE" PARAGRAPH 4.74.
2. REACTOR FEEDWATER PUMP TURBINE SHOWN ON GE DWG. 508-4190C.
3. CONDENSER SHOWN ON I-R DWG N4-WR084-501X116 (SHEETS).
4. MAIN STEAM STOP AND CONTROL VALVE ASSEMBLY SHOWN ON GE DWG. 832E057
5. ALL PANELS AND RACKS ARE PREFIXED THIS UNLESS OTHERWISE NOTED.
6. PROCESS DATA SHOWN IN THE OPERATING DATA TABLE ON THIS SYSTEM DIAGRAM SHALL BE USED IN CONJUNCTION WITH THE DESIGN BASIS INFORMATION AND SHALL BE USED WITH CAUTION. IN GENERAL, THE OPERATING DATA (PRESSURES, TEMPERATURES, AND FLOWS) PROVIDED ON THIS DRAWING, REPRESENTS THE MOST COMMON OPERATING CONDITION AND/OR SYSTEM MODE OF OPERATION AND/OR LINEUP. TO DETERMINE THE REQUIRED VALUES FOR A SPECIFIC OPERATING CONFIGURATION, THE APPROPRIATE DESIGN DOCUMENTS NEED TO BE REVIEWED.
7. OPERATING DATA IS TYPICALLY DERIVED FROM GE THERMAL KIT HEAT BALANCES. THE THERMAL KIT HEAT BALANCES ARE KEPT IN DESIGN INPUT RECORD (DIR) 237. OPERATING DATA SHOWN IS FOR RATED CONDITIONS APPLICABLE TO THE IMPLEMENTATION OF THE FOLLOWING PLANT CHANGES:
  - a) POWER UPGRADE TO 105% OF THE ORIGINAL DESIGN (REF.: IAF 01794)
  - b) PARTIAL ARC ADMISSION (REF.: DCP 98-0050) NOTE: PARTIAL ARC PARAMETER CHANGES (UP & DOWN) ARE SHOWN ONLY IF THEY ARE GREATER THAN 1% OF THE POWER UPGRADE VALUES.
  - c) LOW PRESSURE TURBINE ROTOR REPLACEMENT (REF.: ECP 04-0070).
8. THIS PORTION OF PIPING IS DESIGNATED AS E32 (MSIV LEAKAGE CONTROL) FOR ASME CODE PURPOSES ONLY.

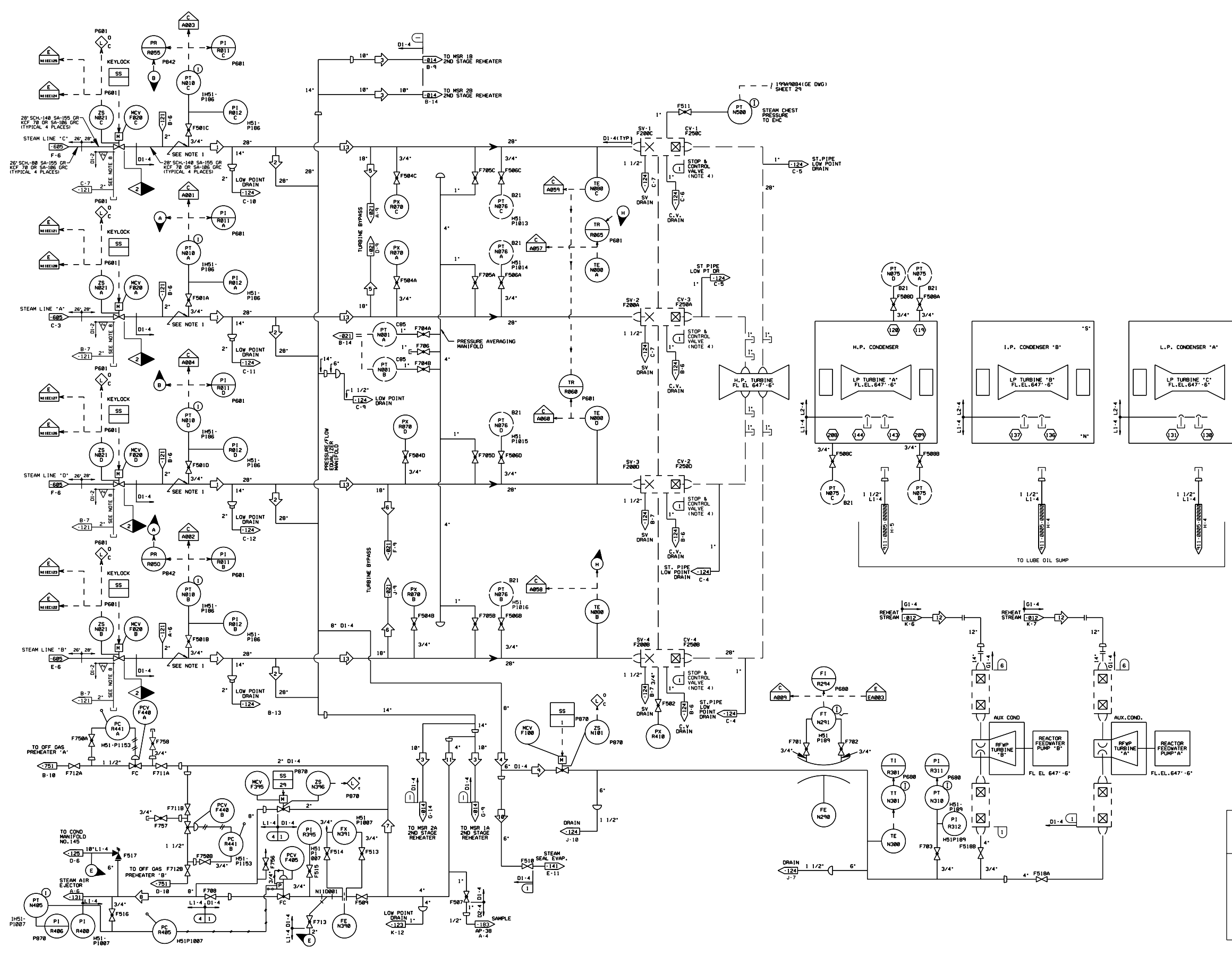

(Rev. 18 10/13)

PERRY NUCLEAR POWER PLANT  
10 CENTER RD., PERRY, OHIO 44081

MAIN STEAM SYSTEM, UNIT 1

FIGURE 10.1-1 (SHEET 1 OF 3)  
(DWG. D-302-0011-00000)

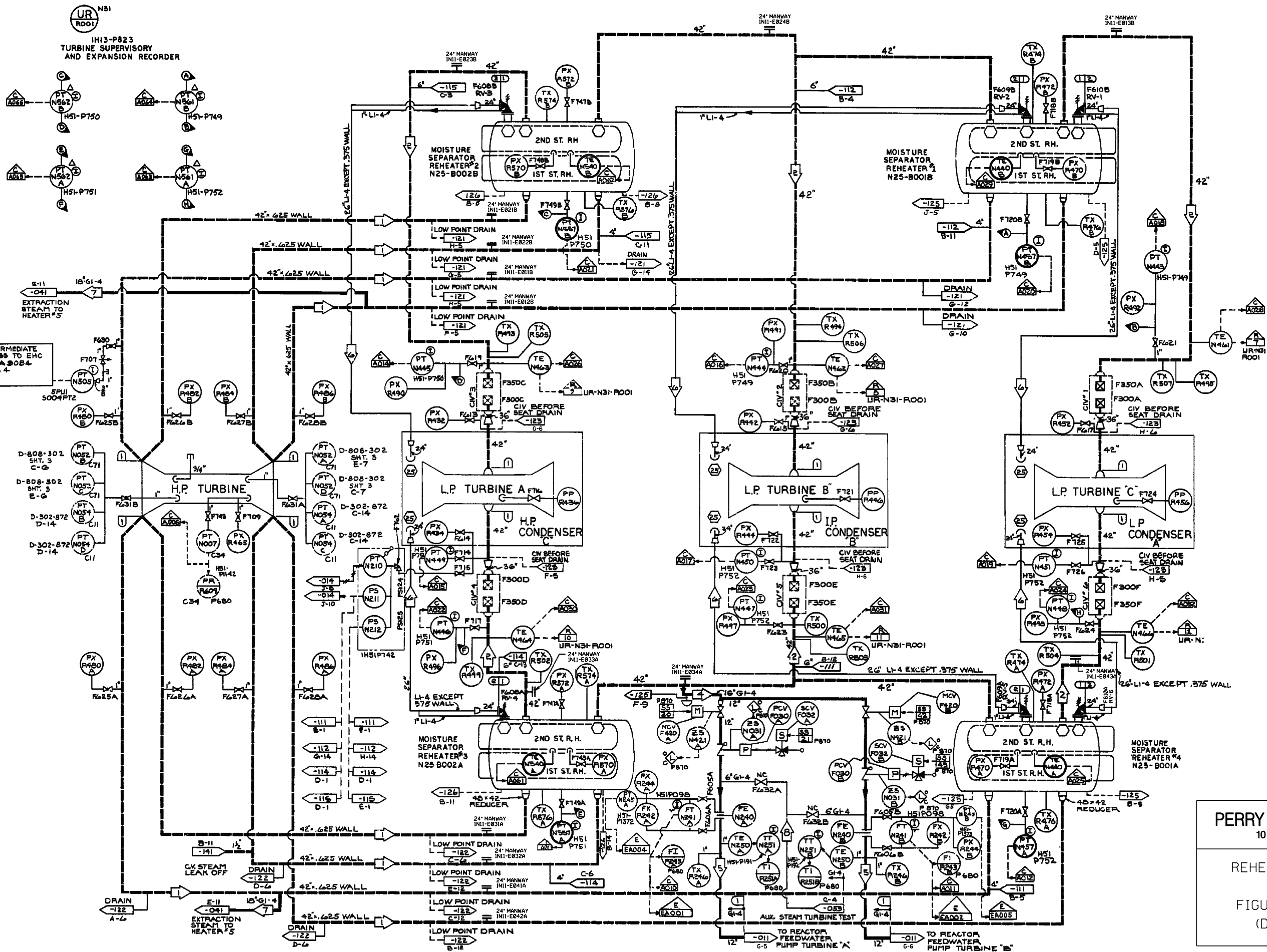

OPERATING DATA (RATED)

SEE NOTES 2, 3

ID	PSIG	LB/HR	°F	REMARKS
1	180	1638352	380	
2	169	1885721	511	
4	164	189695	512	
5	164	94847	512	
6	93	2,100,000	515	
7	180	382533	380	
8	150	20,000	368	RFPT TEST

DESIGN DATA

ID	NORMAL PSIG	UPSET °F	PSIG	°F	TIME	REMARKS
1	248	510				
2	140	515				

- REFERENCES:
- 382-0011-00000 MAIN STEAM SYSTEM N11
  - 382-0041-00000 EXTRACTION STEAM N06
  - 382-0052-00000 AUXILIARY STEAM P01
  - 382-0121-00000 MAIN, REHEAT, EXTRACTION AND MISCELLANEOUS DRAINS N22
  - 382-0122-00000 MAIN, REHEAT, EXTRACTION AND MISCELLANEOUS DRAINS N22
  - 382-0123-00000 MAIN, REHEAT, EXTRACTION AND MISCELLANEOUS DRAINS N22
  - 382-0125-00000 MAIN, REHEAT, EXTRACTION AND MISCELLANEOUS DRAINS N22
  - 8208531CA G.E. REACTOR PROTECTION SYSTEM ELEMENTARY C71
  - 851E478 G.E. ROD CONTROL AND INFORMATION SYSTEM ELEMENTARY C11
  - 891E567 G.E. FEEDWATER CONTROL SYSTEM IEO C34
  - 11949884 G.E. TURBINE INTERCONNECTION DIAGRAM

- NOTES:
- ALL PANELS AND RACKS ARE PREFIXED IH3, UNLESS OTHERWISE NOTED.
  - PROCESS DATA SHOWN IN THE OPERATING DATA TABLE ON THIS SYSTEM DIAGRAM SHALL BE USED IN CONJUNCTION WITH THE DESIGN BASIS INFORMATION AND SHALL BE USED WITH CAUTION. IN GENERAL, THE OPERATING DATA (PRESSURES, TEMPERATURES, AND FLOWS) PROVIDED ON THIS DRAWING, REPRESENTS THE MOST COMMON OPERATING CONDITION AND/OR SYSTEM MODE OF OPERATION AND/OR LINEUP. TO DETERMINE THE REQUIRED VALUES FOR A SPECIFIC OPERATING CONFIGURATION, THE APPROPRIATE DESIGN DOCUMENTS NEED TO BE REVIEWED.
  - OPERATING DATA IS TYPICALLY DERIVED FROM GE THERMAL KIT HEAT BALANCES. THE THERMAL KIT HEAT BALANCES ARE KEPT IN DESIGN INPUT RECORD (DIR) 237. OPERATING DATA SHOWN IS FOR RATED CONDITIONS APPLICABLE TO THE IMPLEMENTATION OF THE FOLLOWING PLANT CHANGES:
    - a.) POWER UPRATE TO 105% OF THE ORIGINAL DESIGN (REF. TAF 91794).
    - b.) PARTIAL ARC ADMISSION (REF. DCP 98-0050) NOTE: PARTIAL ARC PARAMETER CHANGES (UP & DOWN) ARE SHOWN ONLY IF THEY ARE GREATER THAN 1% OF THE POWER UPRATE VALUES.
    - c.) LOW PRESSURE TURBINE ROTOR REPLACEMENT (REF. ECP 04-0078).

(Rev. 18 10/13)

**PERRY NUCLEAR POWER PLANT**  
 10 CENTER RD., PERRY, OHIO 44081

REHEAT STEAM SYSTEM, UNIT 1

FIGURE 10.1-1 (SHEET 2 OF 3)  
 (DWG. D-302-0012-00000)

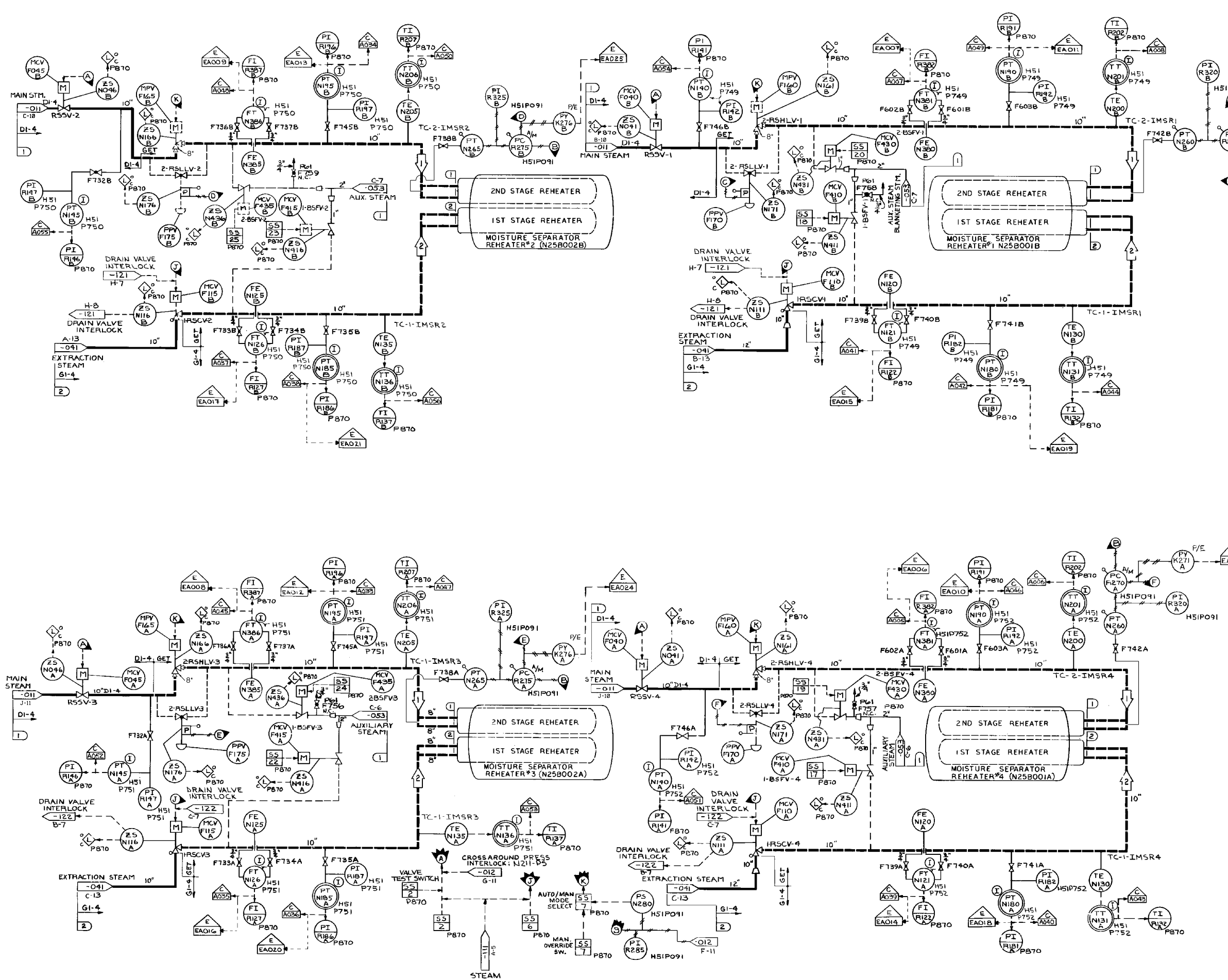

OPERATING DATA (RATED)				
SEE NOTES 2, 3				
LINE NO.	PSIG	LB/HR	°F	REMARKS
1	959	186954	541	75% LOAD
2	546	195854	479	

DESIGN DATA					
LINE NO.	NORMAL PSIG	NORMAL °F	UPSET PSIG	UPSET °F	REMARKS
1	1250	575			
2	620	495			

- NOTES:
- ALL PANELS AND RACKS ARE PREFIXED IH3, UNLESS OTHERWISE NOTED.
  - PROCESS DATA SHOWN IN THE OPERATING DATA TABLE ON THIS SYSTEM DIAGRAM SHALL BE USED IN CONJUNCTION WITH THE DESIGN BASIS INFORMATION AND SHALL BE USED WITH CAUTION. IN GENERAL, THE OPERATING DATA (PRESSURES, TEMPERATURES, AND FLOWS) PROVIDED ON THIS DRAWING REPRESENTS THE MOST COMMON OPERATING CONDITION AND/OR SYSTEM MODE OF OPERATION AND/OR LINEUP. TO DETERMINE THE REQUIRED VALUES FOR A SPECIFIC OPERATING CONFIGURATION, THE APPROPRIATE DESIGN DOCUMENTS NEED TO BE REVIEWED.
  - OPERATING DATA IS TYPICALLY DERIVED FROM GE THERMAL KIT HEAT BALANCES. THE THERMAL KIT HEAT BALANCES ARE KEPT IN DESIGN INPUT RECORD (DIR) 237. OPERATING DATA SHOWN IS FOR RATED CONDITIONS APPLICABLE TO THE IMPLEMENTATION OF THE FOLLOWING PLANT CHANGES:
    - a) POWER UPGRADE TO 105% OF THE ORIGINAL DESIGN (REF.: IAF 81794)
    - b) PARTIAL ARC ADMISSION (REF.: DCP 98-0050)
    - NOTE: PARTIAL ARC PARAMETER CHANGES UP & DOWN ARE SHOWN ONLY IF THEY ARE GREATER THAN 1% OF THE POWER UPGRADE VALUES.
    - c) LOW PRESSURE TURBINE ROTOR REPLACEMENT (REF.: ECP 04-0070).

- REFERENCES:
- 302-0011-00000 MAIN STEAM SYSTEM N11
  - 302-0012-00000 REHEAT STEAM SYSTEM N11
  - 302-0041-00000 EXTRACTION STEAM N36
  - 302-0111-00000 HIGH PRESSURE HEATER DRAINS AND VENTS 'A' N25
  - 302-0121-00000 MAIN, REHEAT, EXTRACTION AND MISCELLANEOUS DRAINS N22
  - 43-0099-00000 REHEATER HEATING STEAM PIPING/PROTECTION DIAGRAM GET

(REV. 20 10/2017)

**PERRY NUCLEAR POWER PLANT**  
10 CENTER RD., PERRY, OHIO 44081

---

**REHEATER HEATING STEAM SYSTEM**

---

FIGURE 10.1-1 (SHEET 3 OF 3)  
(DWG. D-302-0014-00000)

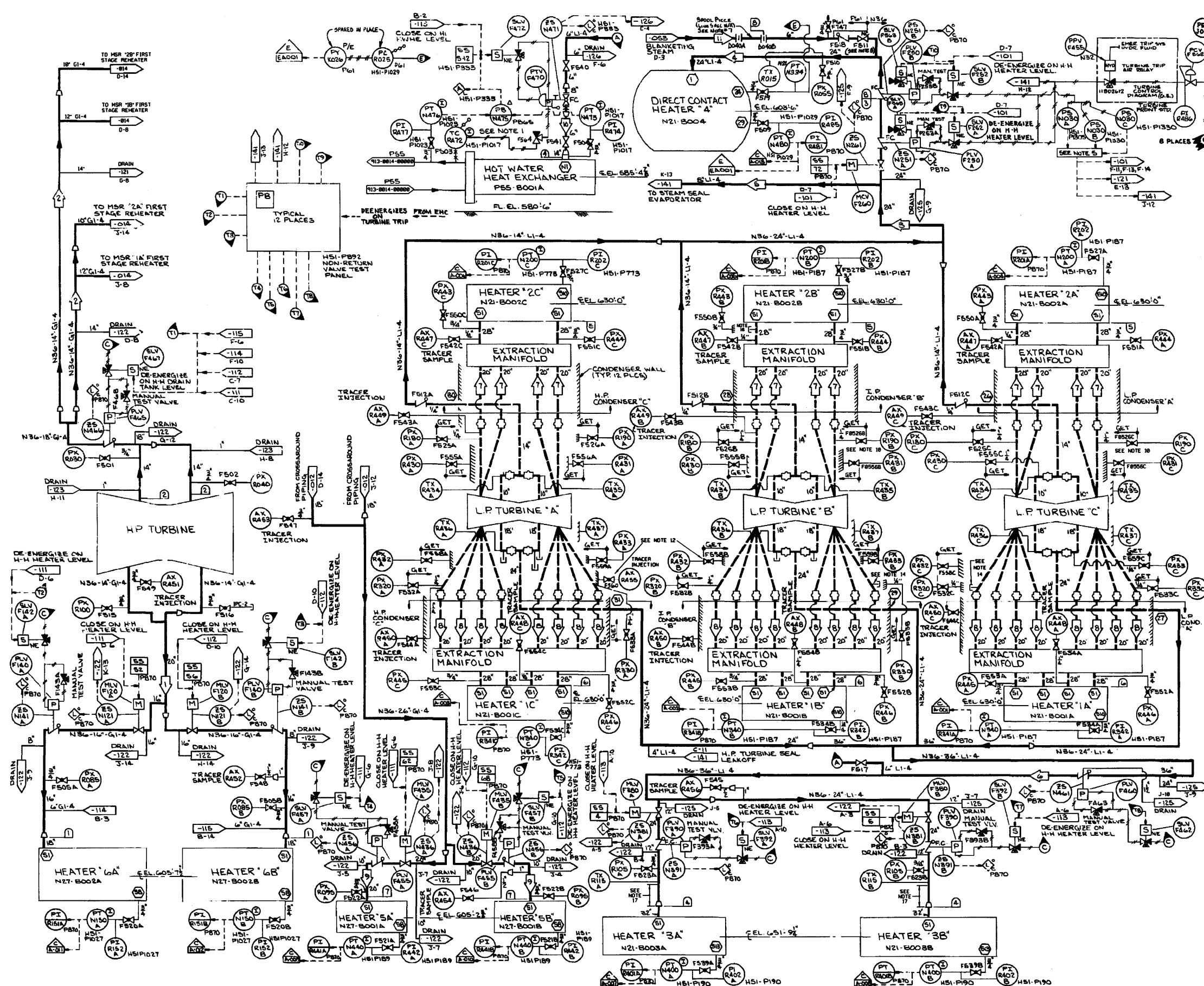

OPERATING DATA (RATED)  
SEE NOTES 9 & 11

LINE	LB/HR	PSIA	°F	REMARKS
1	873,789	362	438	4th STAGE EXTRACTION
2	371,789	561	479	2nd STAGE
3	382,119	187	412	8th STAGE
4	386,758	187	412	8th STAGE
5	23,361	187	412	8th STAGE
6	789,824	64	318	9th STAGE
7	54,909	19.6	227	11th STAGE (VAPOR)
8	1,497	19.6	227	11th STAGE (MOISTURE)
9	19,228	5.3	164	13th STAGE (VAPOR)
10	5,387	5.3	164	13th STAGE (MOISTURE)
11	4,774	5.3	164	12th STAGE (MOISTURE BLOWDOWN)
12	382,833	195	388	
13	48,888	65.4	286	
14	8	165	366	MAXIMUM SHUTDOWN

- REFERENCES:
- 382-0014-00000 REHEAT HEATING STEAM SYSTEM N11
  - 382-0101-00000 CONDENSATE SYSTEM N21
  - 382-0111-00000 HIGH PRESSURE HEATER DRAINS AND VENTS "W" SYSTEM N25
  - 382-0112-00000 HIGH PRESSURE HEATER DRAINS AND VENTS "Y" SYSTEM N25
  - 382-0113-00000 LOW PRESSURE HEATER DRAINS AND VENTS SYSTEM N25
  - 382-0121-00000 MAIN REHEAT, EXTRACTION, AND MISCELLANEOUS DRAINS SYSTEM N22
  - 382-0122-00000 MAIN REHEAT, EXTRACTION, AND MISCELLANEOUS DRAINS SYSTEM N22
  - 382-0123-00000 MAIN REHEAT, EXTRACTION, AND MISCELLANEOUS DRAINS SYSTEM N22
  - 382-0124-00000 MAIN REHEAT, EXTRACTION, AND MISCELLANEOUS DRAINS SYSTEM N22
  - 382-0141-00000 STEAM SEAL SYSTEM N33
  - 382-0015-00000 HOT WATER HEATING SYSTEM DIAGRAM - HEATER BAY AUXILIARY BUILDING AND TURBINE POWER COUPLER P55
  - 1102S12 TURBINE CONTROL DIAGRAM SYSTEM N32 (G.E.)
  - 382-0114-00000 HIGH PRESSURE HEATER DRAINS AND VENTS "W" SYSTEM N25
  - 382-0115-00000 HIGH PRESSURE HEATER DRAINS AND VENTS "Y" SYSTEM N25
  - 382-0116-00000 EXHAUSTION DIAGRAM (G.E.)
  - 382-0012-00000 REHEAT STEAM SYSTEM N11
  - 413-0014-00000 HOT WATER HEATING SYSTEM P55
  - 382-0120-00000 MAIN REHEAT, EXTRACTION, AND MISCELLANEOUS DRAINS SYSTEM N22
  - 382-0053-00000 AUXILIARY STEAM SYSTEM P61

DESIGN DATA

LINE	NORMAL PSIG	UPSET PSIG	REMARKS
1	395	450	
2	620	495	
3	110	430	
4	75	330	
5	50	240	
6	50	185	
7	200	305	
8	120	430	

- NOTES:
- PRESSURE SUSTAINABLE ENERGIZES WHEN SHELL PRESSURE EXCEEDS TURBINE PRESSURE.
  - ALL INSTRUMENTS AND CONTROL DEVICES CARRY PREFIX NOS. EXCEPT AS NOTED.
  - ALL PANELS OR RACKS ARE PREFIXED 343, UNLESS OTHERWISE NOTED.
  - ALL VALVES IN THE N10S AND N10S HEATER EXTRACTION LINES AND THE 1ST STAGE REHEATER STEAM SUPPLY LINES ARE CARBON STEEL.
  - TWO OUT OF THREE LOGIC.
  - ASME TEST CONNECTION VALVES F8048, 7, C, F8058A, F8058B & C AND F8058C ARE PLUGGED INSIDE THE TURBINE CASING AND NO LONGER IN SERVICE.
  - ORRABAS & B ARE 3/4" THICK BLANK ORIFICE PLATES.
  - VALVE 108F05011 HAS BEEN RENDERED INOPERABLE BY LEAK SEALANT INJECTION.
  - PROCESS DATA SHOWN IN THE OPERATING DATA TABLE ON THIS SYSTEM DIAGRAM SHALL BE USED IN CONJUNCTION WITH THE DESIGN BASIS INFORMATION AND SHALL BE USED WITH CAUTION. IN GENERAL, THE OPERATING DATA PRESSURES, TEMPERATURES, AND FLOWS PROVIDED ON THIS DRAWING REPRESENTS THE MOST COMMON OPERATING CONDITION AND/OR SYSTEM MODE OF OPERATION AND/OR LINEUP. TO DETERMINE THE REQUIRED VALUES FOR A SPECIFIC OPERATING CONFIGURATION, THE APPROPRIATE DESIGN DOCUMENTS NEED TO BE REVIEWED.
  - ASME TEST CONNECTION LINES FOR F8058B AND C ARE REMOVED BETWEEN THE CONDENSER SHELL COUPLING AND THE TURBINE SHELL COUPLING AND ARE NO LONGER IN SERVICE.
  - OPERATING DATA IS TYPICALLY DERIVED FROM DE THERMAL SITT HEAT BALANCES. THE THERMAL SITT HEAT BALANCES ARE KEPT IN DESIGN INPUT RECORD (DIR) 237. OPERATING DATA SHOWN IS FOR RATED CONDITIONS APPLICABLE TO THE IMPLEMENTATION OF THE FOLLOWING PLANT CHANGES:
    - A. POWER UPGRADE TO 105% OF ORIGINAL DESIGN (REF. TAF 81794)
    - B. PARTIAL ARC ADMISSION (REF. DCP 90-0808)
    - NOTE: PARTIAL ARC CHANGES UP OR DOWN ARE SHOWN ONLY IF THEY ARE GREATER THAN 1% OF THE POWER UPGRADE VALUES.
    - C. LOW PRESSURE TURBINE ROTOR REPLACEMENT (REF. E-84-1070).
  - ASME TEST CONNECTION LINES FOR F8058B & F8058C ARE CUT OFF & CAPPED ON THE CONDENSER END INTERNAL TO THE CONDENSER. THESE VALVES SHOULD REMAIN CLOSED.
  - ASME TEST CONNECTION LINES FOR F8052A, F8059A & F8059B ARE CUT OFF & CAPPED ON THE CONDENSER END INTERNAL TO THE CONDENSER. THE VALVES SHOULD REMAIN CLOSED.
  - ASME TEST CONNECTION LINES FOR F8053C & F8053B ARE REMOVED BETWEEN COND. SHELL/TURBINE & CAPPED AT TURBINE. VALVES SHOULD REMAIN CLOSED.
  - VENDOR DRAWING 43-9188-0000 PROVIDES FUNCTIONAL LOCATIONS FOR THE EXTRACTION STEAM METAL BELLOWS EXPANSION JOINTS ASSOCIATED WITH LOW PRESSURE TURBINE A AND B. VENDOR DRAWING 43-9187-0000 PROVIDES FUNCTIONAL LOCATIONS FOR THE EXTRACTION STEAM METAL BELLOWS EXPANSION JOINTS ASSOCIATED WITH LOW PRESSURE TURBINE C. NAMING CONVENTION FOR THE FUNCTIONAL LOCATIONS IS GIVEN BELOW.
    - FLOC: PT-1102080414
    - DESCRIPTION: 8TH STAGE EXTR. STM TO PV OF HTR 4
    - WHERE:
      - 11" BELLOWS 1' FROM LV TURB A
      - 11" BELLOWS 1' FROM LV TURB B
      - 11" BELLOWS 1' FROM LV TURB C
  - ASME TEST CONNECTION LINE FOR VALVE PV-1102080808 IS REMOVED BETWEEN THE PT-1102080828 NOZZLE COUPLING AND THE CONDENSER SHELL COUPLING AND PLUGGED AT THE PT-1102080828 NOZZLE COUPLING.
  - EXCEPTION ON LINE SPEC L1-4, THE 32" 24" REDUCER AND THE FIRST 24" ELBOW UPSTREAM OF THE REDUCER ARE CHROME-MOLY. VALVES SHOULD REMAIN CLOSED.

(REV. 19 10/2015)

**PERRY NUCLEAR POWER PLANT**  
10 CENTER RD., PERRY, OHIO 44081

---

EXTRACTION STEAM

---

FIGURE 10.1-2  
(DWG. D-302-0041-00000)



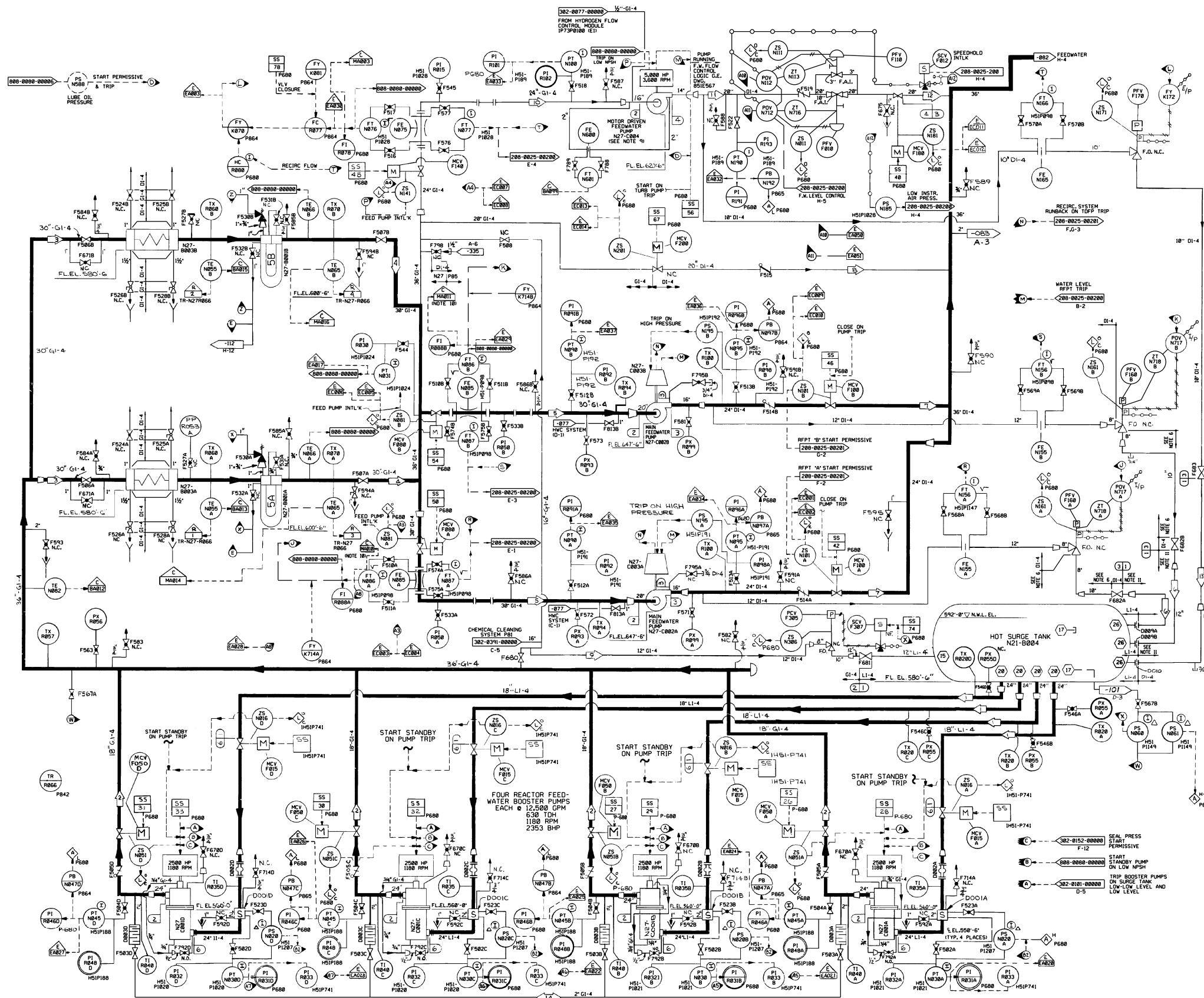

OPERATING DATA (RATED)

SEE NOTES 7, 8

PSIA	GPM	F	REMARKS
1	180	11,991	329
2	362	11,981	329
3	345	17,996	329
4	315	18,494	370
5	292	18,494	370
6	10	4,000	125
7	1127	18,436	372
8	208	7,500	75
9	208	5,000	125
10	292	6,300	369
11	1128	6,278	370
12	1805	6,278	370
13	98	4,000	125
14	308	25-110	329

DESIGN DATA

PSIG	F	PSIG	F	TIME	REMARKS
1	120	350	120	350	
2	500	400	500	400	
3	1500	400	1500	400	
4	1540	400	1540	400	
5	120	400	120	400	
6	145	350	145	350	SEE NOTE 12 FOR STRAINERS IN270000A, B, C, & D

- NOTES:
- ITEMS SUPPLIED BY D.E. HAVE PREFIX B21.
  - SEAL WATER SUPPLY PRESSURE 310 PSIA.
  - PIPING DRAINS ARE 1" AND PIPING VENTS ARE 3/4" UNLESS OTHERWISE NOTED.
  - ALL INSTRUMENTS AND CONTROLS ARE PREFIXED IN27, UNLESS OTHERWISE NOTED.
  - ALL PANEL AND RACKS CARRY PREFIX IH3, UNLESS OTHERWISE NOTED.
  - PIPE TO BE ASTM A312 TP 316L.
  - PROCESS DATA SHOWN IN THE OPERATING DATA TABLE ON THIS SYSTEM DIAGRAM SHALL BE USED IN CONJUNCTION WITH THE DESIGN BASIS INFORMATION AND SHALL BE USED WITH CAUTION. IN GENERAL, THE OPERATING DATA (PRESSURES, TEMPERATURES, AND FLOWS) PROVIDED ON THIS DRAWING REPRESENTS THE MOST COMMON OPERATING CONDITION, AND/OR SYSTEM MODE OF OPERATION AND/OR LINEUP. TO DETERMINE THE REQUIRED VALUES FOR A SPECIFIC OPERATING CONFIGURATION, THE APPROPRIATE DESIGN DOCUMENTS NEED TO BE REVIEWED.
  - OPERATING DATA IS TYPICALLY DERIVED FROM GE THERMAL KIT HEAT BALANCES. THE THERMAL KIT HEAT BALANCES ARE KEPT IN DESIGN INPUT RECORD 000237. OPERATING DATA SHOWN IS FOR RATED CONDITIONS APPLICABLE TO THE IMPLEMENTATION OF THE FOLLOWING PLANT CHANGES:
    - POWER UPGRADE TO 100% OF ORIGINAL DESIGN (REF. TAF 81794)
    - PARTIAL ARC ADMISSION (REF. DCP 98-0950) NOTE: PARTIAL ARC PARAMETER CHANGES UP & DOWN ARE SHOWN ONLY IF THEY ARE GREATER THAN 1% OF THE POWER UPGRADE VALUES.
    - LOW PRESSURE TURBINE ROTOR REPLACEMENT (REF. TAF 84-0070).
  - SEE DRAWING 26-8179-00001 FOR THE LUBE OIL SYSTEM COMPONENT INTERFACES WITH THE MOTOR DRIVEN FEEDWATER PUMP IN2700004.
  - COMPUTER POINTS MA810 AND MA811 PROVIDE AVERAGE FEEDWATER PUMP SECTION FLOW RATES - MA810 AVERAGES TRANSMITTERS IN2700006 & 874; MA811 AVERAGES IN2700006 & 876.
  - PIPE TO BE A335 GRADE P22.
  - F.W. BOOSTER PUMP STRAINERS IN2700001 (A, B, C, & D) HAVE A MAXIMUM WORKING PRESSURE OF 125 PSIG AT 350°F.
  - DELETED

- REFERENCES:
- 200-0025-00000 FEEDWATER CONTROL SYSTEM
  - 200-0149-00000 FEEDWATER ELEMENTARY DIAGRAM
  - 302-0002-00000 FEEDWATER N27
  - 302-0003-00000 FEEDWATER PUMP INJECTION AND WARM-UP
  - 302-0101-00000 CONDENSATE SEAL SYSTEM N21
  - 302-0152-00000 CONDENSATE SEAL SYSTEM P12
  - 302-0243-00000 M.F.P. TURBINE LUBE OIL FLOW DIAGRAM
  - 302-0245-00000 EXTENDED M.F.P. TURBINE "A" FLOW DIAGRAM
  - 302-0246-00000 EXTENDED M.F.P. TURBINE "B" FLOW DIAGRAM
  - 302-0391-00000 CHEMICAL CLEANING SYSTEM P01
  - 000-0000-00000 FEEDWATER LOOP DIAGRAMS
  - 26-8179-00001 LUBE OIL SYSTEM DIAGRAM FOR IN2700004

(REV. 22 10/2021)

PERRY NUCLEAR POWER PLANT  
10 CENTER RD., PERRY, OHIO 44081

FEEDWATER  
FIGURE 10.1-3 (SHEET 1 OF 2)  
(DWG. D-302-0081-00000)

OPERATING DATA (RATED)				
PSIA	GPM	°F	REMARKS	
1	1127	18,436	372	
2	1113	19,188	425	
3	1113	38,377	425	
4	1100	19,188	425	
5	250	12,000	125	START-UP
6	935	600	125	START-UP
7	250	400	125	START-UP WITH D0594 OPEN

DESIGN DATA					
D	NORMAL	UPSET	TIME	REMARKS	
	PSIG	°F	PSIG	°F	
1	1500	400	1500	400	
2A	1500	450	1500	450	
2B	1250	550	1500	550	<1%
2C	1250	575	1500	575	
3A	50	150	50	150	
3B	1250	575	1250	575	

\* SEE NOTE 7

- NOTES:
- ALL PANELS AND RACKS ARE PREFIXED I1I3, UNLESS OTHERWISE NOTED.
  - ALL INSTRUMENTS AND CONTROLS ARE PREFIXED I1N27, UNLESS OTHERWISE NOTED.
  - PIPING DRAINS ARE 1" AND PIPING VENTS ARE 3/4", UNLESS OTHERWISE SPECIFIED.
  - TWO SETS OF PRESSURE TAPS ARE PROVIDED ON EACH FEEDWATER FLOW METER SECTION. PROCESS INSTRUMENT PIPING/TUBING SHALL BE RUN FROM BOTH SETS OF TAPS WITH ONE SET PERMANENTLY CONNECTED TO THE FEEDWATER FLOW TRANSMITTER AND THE ALTERNATE SET TERMINATING ADJACENT TO THE FLOW TRANSMITTER COMPLETE WITH BLOWDOWN INSTRUMENT SHUTOFF, AND EQUALIZING VALVE MANIFOLD TO FACILITATE IN-SERVICE MONITORING OF FLOW ELEMENT CALIBRATION UTILIZING EITHER SET OF PRESSURE TAPS.
  - CONTROLLED CLOSURE ANTIWATER HAMMER LIFT CHECK VALVES.
  - CLASS 2 PIPING MUST MEET TESTING REQUIREMENTS OF ASME III, NB-2300.
  - THE DATA IN THE NORMAL COLUMN ARE THE SYSTEM DESIGN CONDITION.
  - 3/4" DOUBLE ROOT VALVES EMANATING FROM SAFETY CLASS 1 PIPING ARE SAFETY CLASS 2 AT THE POINT OF CONNECTION WITH 3/4" PIPE OR FITTING AND CLASS 1 PIPE.
  - PROCESS DATA SHOWN IN THE OPERATING DATA TABLE ON THIS SYSTEM DIAGRAM SHALL BE USED IN CONJUNCTION WITH THE DESIGN BASIS INFORMATION AND SHALL BE USED WITH CAUTION. IN GENERAL, THE OPERATING DATA (PRESSURES, TEMPERATURES, AND FLOWS) PROVIDED ON THIS DRAWING REPRESENTS THE MOST COMMON OPERATING CONDITION AND/OR SYSTEM MODE OF OPERATION AND/OR LINE-UP. TO DETERMINE THE REQUIRED VALUES FOR A SPECIFIC OPERATING CONFIGURATION, THE APPROPRIATE DESIGN DOCUMENTS NEED TO BE REVIEWED.
  - OPERATING DATA IS TYPICALLY DERIVED FROM GE THERMAL KIT HEAT BALANCES. THE THERMAL KIT HEAT BALANCES ARE KEPT IN DESIGN INPUT RECORD (DIR) 237. OPERATING DATA SHOWN IS FOR RATED CONDITIONS APPLICABLE TO THE IMPLEMENTATION OF THE FOLLOWING PLANT CHANGES:
    - POWER UPGRADE TO 105% OF THE ORIGINAL DESIGN (REF: TAF 81794).
    - PARTIAL ARC ADMISSION (REF: DCP 98-0050) NOTE: PARTIAL ARC PARAMETER CHANGES UP & DOWN ARE SHOWN ONLY IF THEY ARE GREATER THAN 1% OF THE POWER UPGRADE VALUES.
    - LOW PRESSURE TURBINE ROTOR REPLACEMENT (REF: ECP 04-0070).
  - REQUIRED PIPE FROM PIPING HAVING A DESIGN TEMPERATURE OF 575°F TO PIPING HAVING A DESIGN TEMPERATURE OF 550°F.

- 302-0081-00000 FEEDWATER N27
- 302-0103-00000 CONDENSING - SYSTEM N21
- 302-0111-00000 HIGH PRESSURE HEATER DRAINS AND VENTS 'A' N25
- 302-0183-00000 TURBINE PLANT SAMPLING SYSTEM P33
- 302-0642-00000 RESIDUAL HEAT REMOVAL E12
- 208-0025-00000 FEEDWATER CONTROL SYSTEM C34
- 808-0101-00000 CONDENSATE SYSTEM HOT SURGE TANK 3 ELEMENT
- 302-0971-00000 FEEDWATER LEAKAGE CONTROL SYSTEM N27
- 302-0222-00000 TURBINE BUILDING CLOSED COOLING SYSTEM P44

(REV. 22 10/2021)

PERRY NUCLEAR POWER PLANT  
10 CENTER RD., PERRY, OHIO 44081

FEEDWATER  
FIGURE 10.1-3 (SHEET 2 OF 2)  
(DWG. D-302-0082-00000)

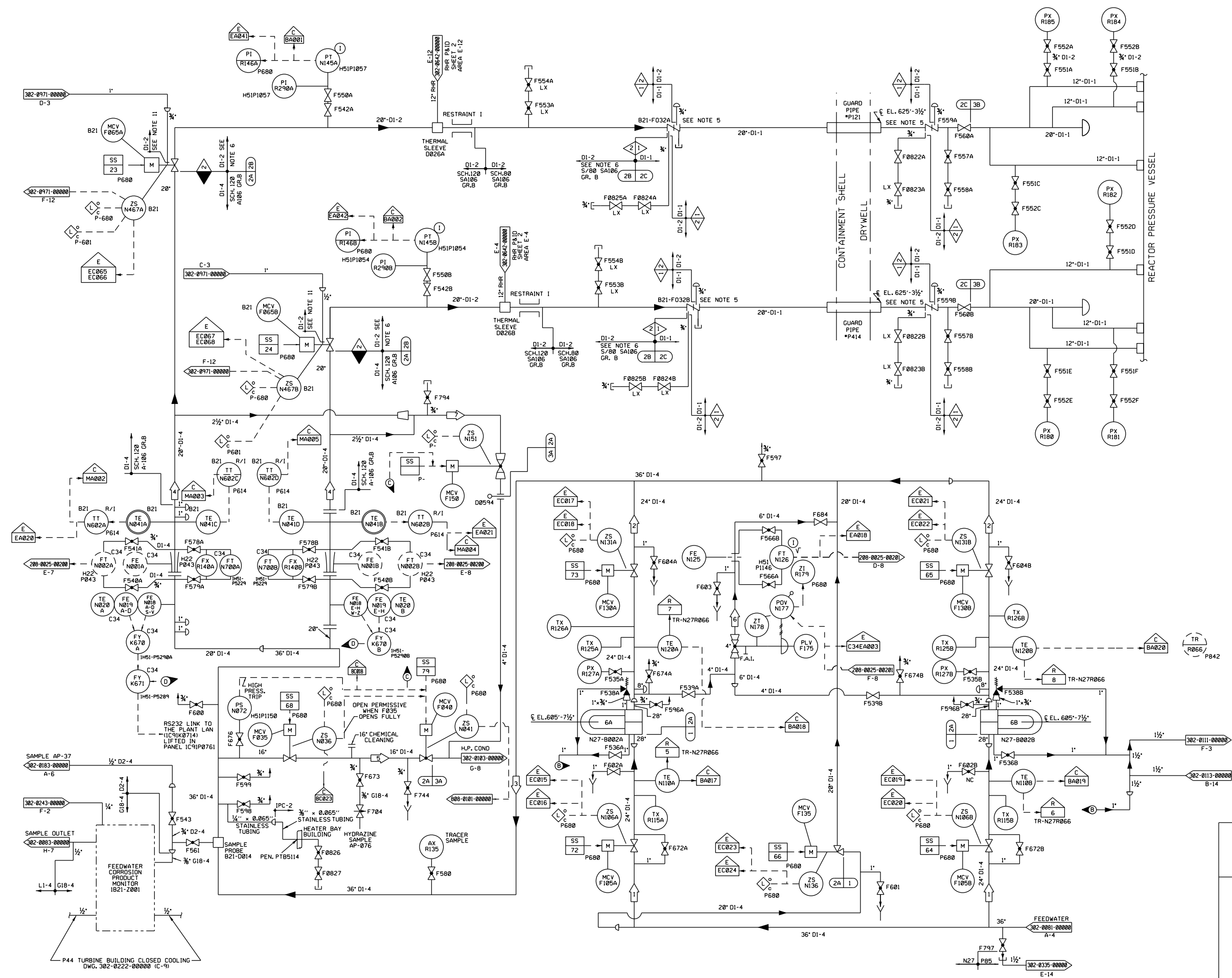

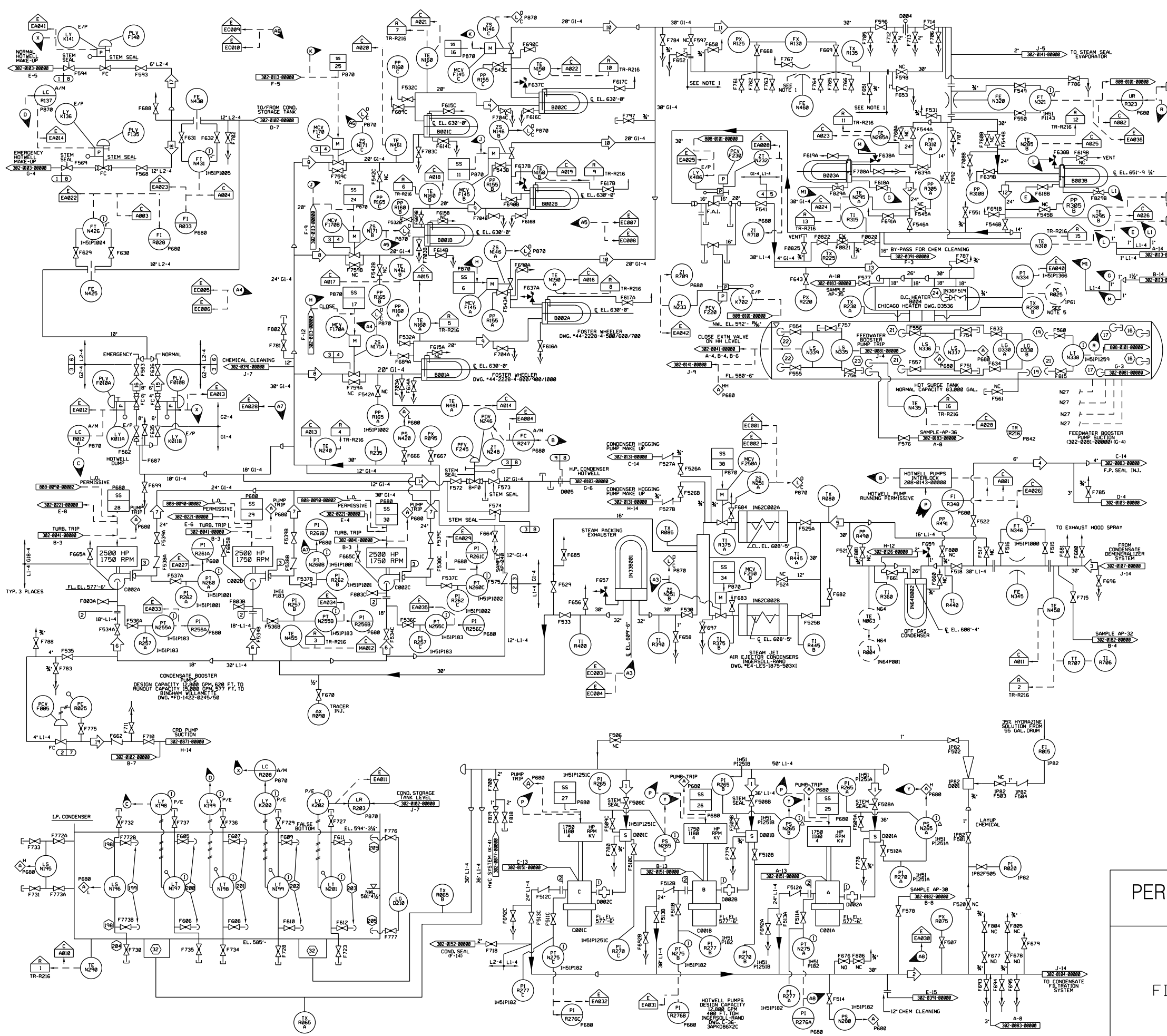

**OPERATING DATA**  
SEE NOTES 6,7

#	PSIA	GPM	°F	REMARKS
1	VAC	11,251	181.1	RATED
2	190	22,502	181.3	RATED
3	124	22,502	181.3	RATED
4	124	200	181.3	RATED
5	114	22,308	182.4	RATED
6	95	11,129	184.3	RATED
7	352	7,112	184.4	RATED
8	338	7,415	184.9	RATED
9	319	7,522	157.2	RATED
10	308	7,708	219.1	RATED
11	308	23,100	219.1	RATED
12	293	11,923	288.6	RATED
13	185	23,647	288.6	RATED
14	448	5,000	183.4	STARTUP (3500 MIN.)
15	12	1,000	183.4	INTERMITTENT
16	12	2,000	183.4	INTERMITTENT
17	28	1,000	65	INTERMITTENT
18	28	2,000	65	INTERMITTENT
19	58	68	184.3	

**DESIGN DATA**

#	NORMAL	UPSET	REMARKS	
	PSIG	°F	TIME	
1	256	135	256	135
2	250	140	250	140
3	580	140	580	140
4	580	328	1000	328
5	120	358	100	358
6	58	148	58	148
7	58	148	25	148
8	25	148	25	148

- REFERENCES:**
- 302-0083-00000 FEEDWATER N27
  - 302-0182-00000 CONDENSATE TRANSFER AND STORAGE SYSTEM P11
  - 302-0183-00000 CONDENSING SYSTEM N21
  - 302-0185-00000 CONDENSATE FILTRATION SYSTEM N23
  - 302-0187-00000 CONDENSATE DEMINERALIZER SYSTEM N24
  - 302-0131-00000 CONDENSATE AIR REMOVAL SYSTEM N62
  - 302-0141-00000 STEAM SEAL SYSTEM N33
  - 302-0183-00000 TURBINE PLANT SAMPLING SYSTEM P33
  - 302-0182-00000 TURBINE PLANT SAMPLING SYSTEM P33
  - 302-0391-00000 CHEMICAL CLEANING OF CONDENSATE AND FEEDWATER SYSTEM P43
  - 808-0181-00000 HOT SURGE TANK LOOP DIAGRAM
  - 82825250A FEEDWATER ELEMENTARY DIAGRAM
  - 302-0151-00000 CONDENSATE SEAL P12
  - 302-0152-00000 CONDENSATE SEAL P12
  - 808-0090-00000 CONDENSATE SYSTEM LOOP DIAGRAMS
  - 208-0143-00000 CONDENSATE ELEMENTARY DIAGRAM
  - 302-0113-00000 LOW PRESSURE HEATER, DRAINS, AND VENT
  - 302-0071-00000 CONTROL ROD DRIVE HYDRAULIC SYSTEM C11
  - 302-0081-00000 FEEDWATER SYSTEM N27
  - 302-0041-00000 EXTRACTION STEAM SYSTEM N36
  - 302-0126-00000 MAIN, REHEAT, EXTRACTION, AND MISC. DRAINS SYSTEM N22
  - 302-0221-00000 TURBINE BLDG. CLOSED COOLING SYSTEM P44
  - 302-0077-00000 HYDROGEN WATER CHEMISTRY SYSTEM P73
  - 302-0184-00000 CONDENSATE FILTRATION SYSTEM N23

- NOTES:**
1. PIPING AND COMPONENTS MAY OR MAY NOT BE INSTALLED FOR THE TURBINE TEST OF FLOW NOZZLE N468 COMMON TO UNIT 1 & 2.
  2. ALL PANELS ARE PREFIXED IH3- UNLESS OTHERWISE NOTED.
  3. ALL DRAINS 1" VENTS 3/4" UNLESS OTHERWISE SPECIFIED.
  4. DATA IN THE UPSET COLUMN ARE THE SYSTEM DESIGN CONDITIONS.
  5. VALVE REFERRERS HAS BEEN REMOVED FROM THE SYSTEM AND REPLACED WITH A SPONGE PIECE AND BLANKS. THIS INSTRUMENT IS ABANDONED IN PLACE.
  6. PROCESS DATA SHOWN IN THE OPERATING DATA TABLE ON THIS SYSTEM DIAGRAM SHALL BE USED IN CONJUNCTION WITH THE DESIGN BASIS INFORMATION AND SHALL BE USED WITH CAUTION. IN GENERAL, THE OPERATING DATA (PRESSURES, TEMPERATURES, AND FLOWS) SHOWN ON THIS DRAWING REPRESENTS THE MOST COMMON OPERATING CONDITION AND/OR SYSTEM MODE OF OPERATION AND/OR LINEUP TO OBTAIN THE REQUIRED VALUES FOR A SPECIFIC OPERATING CONFIGURATION. THE APPROPRIATE DESIGN DOCUMENTS NEED TO BE REVIEWED.
  7. OPERATING DATA IS TYPICALLY DERIVED FROM GE THERMAL KIT HEAT BALANCES. THE THERMAL KIT HEAT BALANCES ARE KEPT IN DESIGN INPUT RECORD (DIR) 231. OPERATING DATA SHOWN IS FOR RATED CONDITIONS APPLICABLE TO THE IMPLEMENTATION OF THE FOLLOWING CHANGES:
    - a. POWER UPGRADE TO 100% OF THE ORIGINAL DESIGN (REF. ECP 84-0074)
    - b. PARTIAL ARC ADMISSION (REF. DCP 98-0088)
    - c. NOTIFICATION, ARC PARAMETER CHANGE (UP & DOWN) ARE SHOWN ONLY IF THEY ARE GREATER THAN 1% OF THE ORIGINAL VALUE (REF. ECP 84-0074)
    - d. LOW PRESSURE TURBINE ROTOR REPLACEMENT (REF. ECP 84-0074)

(REV. 22 10/2021)

**PERRY NUCLEAR POWER PLANT**  
10 CENTER RD., PERRY, OHIO 44081

**CONDENSATE SYSTEM**  
FIGURE 10.1-4 (SHEET 1 OF 2)  
(DWG. D-302-0101-00000)

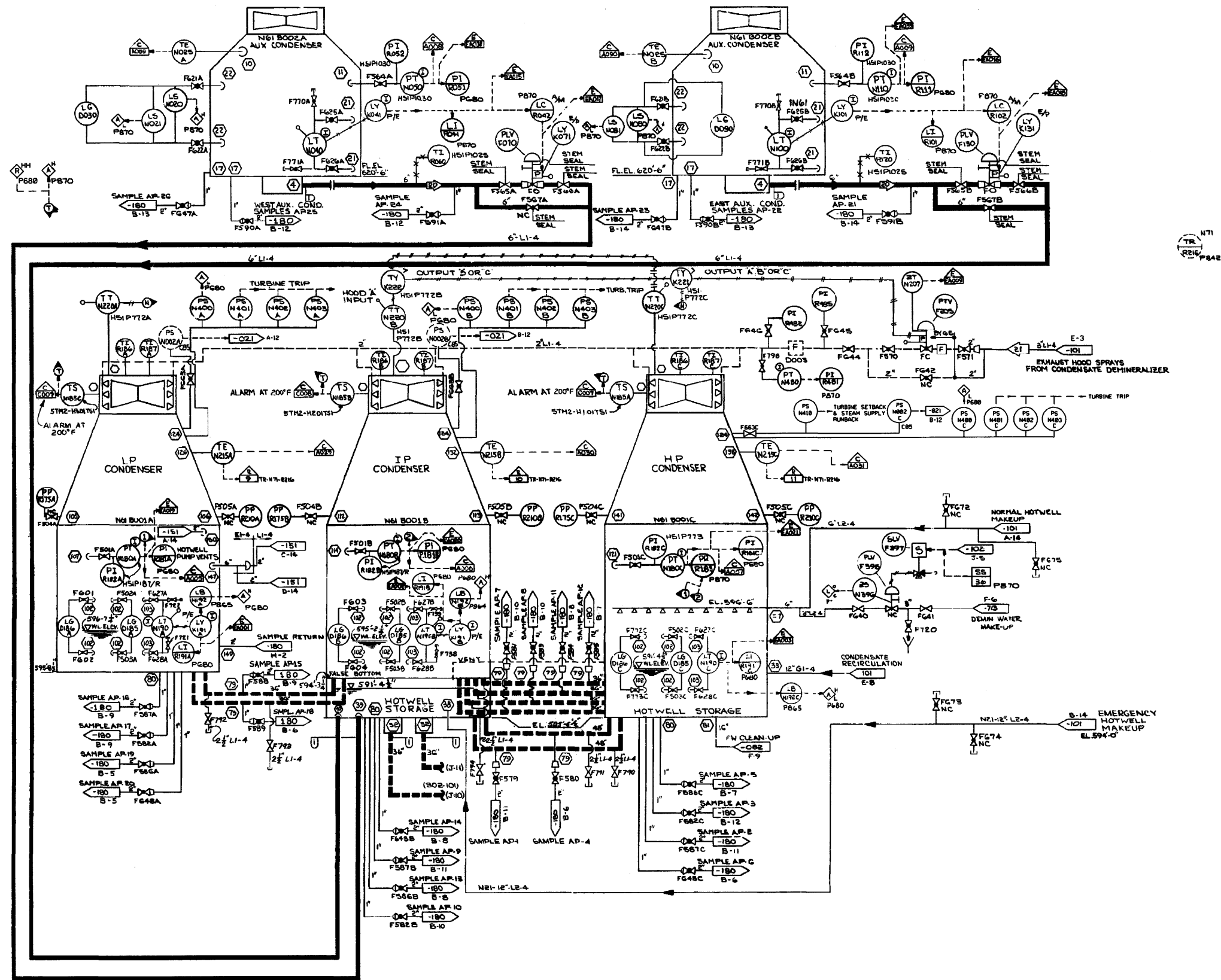

OPERATING DATA (VWO)			
SEE NOTES 6, 7			
PSIA	GPM	F	REMARKS
20	VAC	190	180
21	266	138	181 LOW LOAD

DESIGN DATA			
PSIG	F	PSIG	F TIME
1	25 & V135	25 & V135	

- NOTES:
- CONDENSER SHOWN ON INGERSOLL-RAND DRAWING W-110220-11.
  - EXHAUST HOOD SPRAY CONTROLS ARE SHOWN ON G.E. TURBINE DWG. 110202.
  - ALL INSTRUMENTS AND CONTROLS CARRY PREFIX IN21, UNLESS OTHERWISE SPECIFIED.
  - ALL PANELS ARE PREFIXED IN21, UNLESS OTHERWISE NOTED.
  - AUXILIARY CONDENSER ARRANGEMENT SHOWN ON INGERSOLL-RAND DRAWING E4-16 C11-581X1.
  - PROCESS DATA SHOWN IN THE OPERATING DATA TABLE ON THIS SYSTEM DIAGRAM SHALL BE USED IN CONJUNCTION WITH THE DESIGN BASIS INFORMATION AND SHALL BE USED WITH CAUTION. IN GENERAL, THE OPERATING DATA (PRESSURES, TEMPERATURES, AND FLOWS) PROVIDED ON THIS DRAWING REPRESENTS THE MOST COMMON OPERATING CONDITION AND/OR SYSTEM MODE OF OPERATION AND/OR LINEUP. TO DETERMINE THE REQUIRED VALUES FOR A SPECIFIC OPERATING CONFIGURATION, THE APPROPRIATE DESIGN DOCUMENTS NEED TO BE REVIEWED.
  - OPERATING DATA IS TYPICALLY DERIVED FROM DE THERMAL KIT HEAT BALANCES. THE THERMAL KIT HEAT BALANCES ARE KEPT IN DESIGN INPUT RECORD IN21-237. OPERATING DATA SHOWN IS FOR RATED CONDITIONS APPLICABLE TO THE IMPLEMENTATION OF THE FOLLOWING PLANT CHANGES:
    - a.1 POWER UPGRADE TO 185% OF THE ORIGINAL DESIGN (REF: TAP 8794)
    - b.1 PARTIAL ARC ADMISSION (REF: DCP 98-0088)
 NOTE: PARTIAL ARC PARAMETER CHANGES (UP & DOWN) ARE SHOWN ONLY IF THEY ARE GREATER THAN 1% OF THE POWER UPGRADE VALUES.
- REFERENCES:
- 302-001-00000 MAIN STEAM SYSTEM M11
  - 302-002-00000 FEEDWATER M27
  - 302-003-00000 CONDENSATE SYSTEM M21
  - 302-004-00000 CONDENSATE TRANSFER AND STORAGE SYSTEM P11
  - 302-005-00000 CONDENSATE SEAL P12
  - 302-006-00000 TURBINE PLANT SAMPLING SYSTEM P33
  - 302-007-00000 MIXED-BED DEMINERALIZER AND DISTRIBUTION SYSTEM MIXED-BED EXCHANGER, STORAGE AND NORTH ZONE DISTRIBUTION P22
  - 302-008-00000 STEAM BYPASS AND PRESSURE REGULATION SYSTEM CBS
  - 302-009-00000 REACTOR - TURBINE GENERATOR TRIP DIAGRAM
  - 781E/96 OFF-GAS - LOW TEMPERATURE PAD
  - 110202 TURBINE CONTROL DIAGRAM G.E.T.

(REV. 19 10/2015)

**PERRY NUCLEAR POWER PLANT**  
10 CENTER RD., PERRY, OHIO 44081

CONDENSATE  
SYSTEM  
FIGURE 10.1-4 (SHEET 2 OF 2)  
(DWG. D-302-0103-00000)

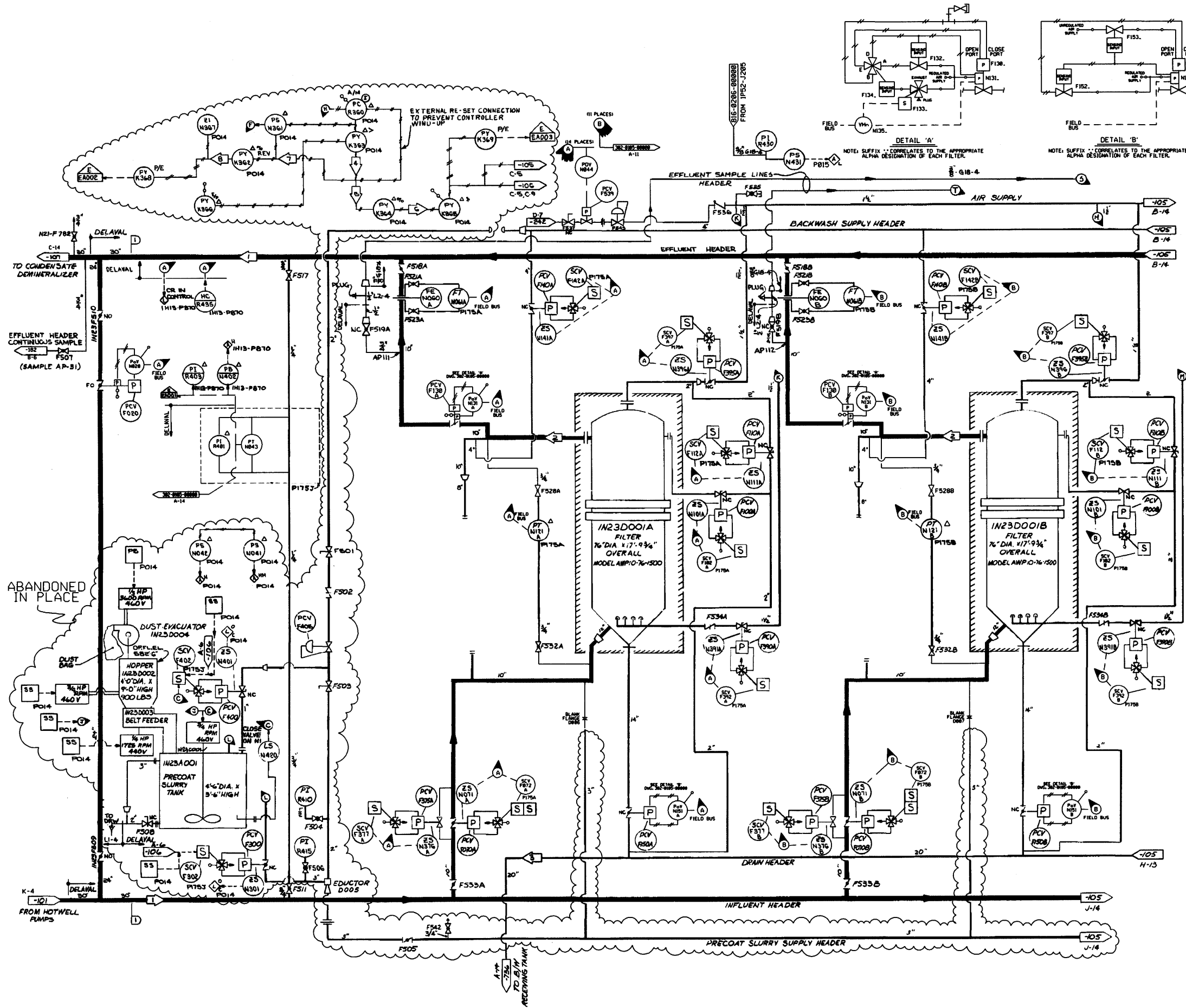

OPERATING DATA  
SEE NOTES 8, 9

ID	PSIG	GPM	F	REMARKS
1	145-175	22,582	181.1	NORMAL
1	175	25,427	148	MAX. FLOW
2	145-175	3,275	181.3	NORMAL
2	175	3633	148	MAX. FLOW
3	180	18,888	181.3	0.2 MIN. DURATION
4	3-15	-	-	-
5	3-9	-	-	-
6	3-15	-	-	-
7	9-15	-	-	-
8	15-3	-	-	-

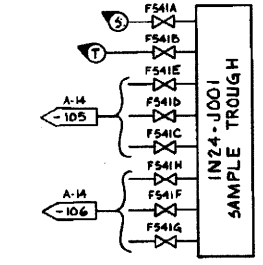

DESIGN DATA

ID	NORMAL		UPSET		REMARKS
	PSIG	F	PSIG	F TIME	
1	250	185	250	148	

- NOTES:
- ALL PANELS AND PACKS ARE PREFIXED IHSI, UNLESS OTHERWISE NOTED.
  - DELETED
  - DELETED
  - DELETED
  - ALL FILTERS AND PRECOAT EQUIPMENT EXCEPT HOPPER STAND ON FLOOR EL. 568'-5" REF.
  - ALL EXTERNAL PIPING, EXCEPT SAMPLE TUBING, IS CARBON STEEL.
  - TYPE 'B' SAMPLE CONNECTION AS SHOWN ON DWG. 382-0771-000000.
  - PROCESS DATA SHOWN IN THE OPERATING DATA TABLE ON THIS SYSTEM DIAGRAM SHALL BE USED IN CONJUNCTION WITH THE DESIGN BASIS INFORMATION AND SHALL BE USED WITH CAUTION. IN GENERAL, THE OPERATING DATA (PRESSURES, TEMPERATURES, AND FLOWS) PROVIDED ON THIS DRAWING, REPRESENTS THE MOST COMMON OPERATING CONDITION, AND/OR SYSTEM MODE OF OPERATION AND/OR LINEUP, TO DETERMINE THE REQUIRED VALUES FOR A SPECIFIC OPERATING CONFIGURATION, THE APPROPRIATE DESIGN DOCUMENTS NEED TO BE REVIEWED.
  - OPERATING DATA IS TYPICALLY DERIVED FROM GE THERMAL KIT HEAT BALANCES. THE THERMAL KIT HEAT BALANCES ARE KEPT IN DESIGN INPUT RECORD (DIR) 237. OPERATING DATA SHOWN IS FOR RATED CONDITIONS APPLICABLE TO THE IMPLEMENTATION OF THE FOLLOWING PLANT CHANGES:
    - a) POWER UPGRADE TO 180% OF THE ORIGINAL DESIGN (REF. IAP 81794)
    - b) PARTIAL ARC ADMISSION (REF. DCP 98-0808)
    - NOTE: PARTIAL ARC PARAMETER CHANGES UP & DOWN ARE SHOWN ONLY IF THEY ARE GREATER THAN 1% OF THE POWER UPGRADE VALUES.
    - c) LOW PRESSURE TURBINE ROTOR REPLACEMENT (REF. ECP 84-0070).

- REFERENCES:
- 382-0101-00000 CONDENSATE SYSTEM N21
  - 382-0105-00000 CONDENSATE FILTRATION SYSTEM N23
  - 382-0106-00000 CONDENSATE FILTRATION SYSTEM N23
  - 382-0107-00000 CONDENSATE DEMINERALIZER SYSTEM N24
  - 382-0102-00000 TURBINE PLANT SAMPLING SYSTEM P33
  - 382-0736-00000 LRV - TANKS AND PUMPS FOR HANDLING CONDENSATE BACKWASH SLURRY CDB

(REV. 19 10/2015)

**PERRY NUCLEAR POWER PLANT**  
 10 CENTER RD., PERRY, OHIO 44081  
  
 CONDENSATE  
 FILTRATION SYSTEM  
 FIGURE 10.1-5 (SHEET 1 OF 3)  
 (DWG. D-302-0104-00000)



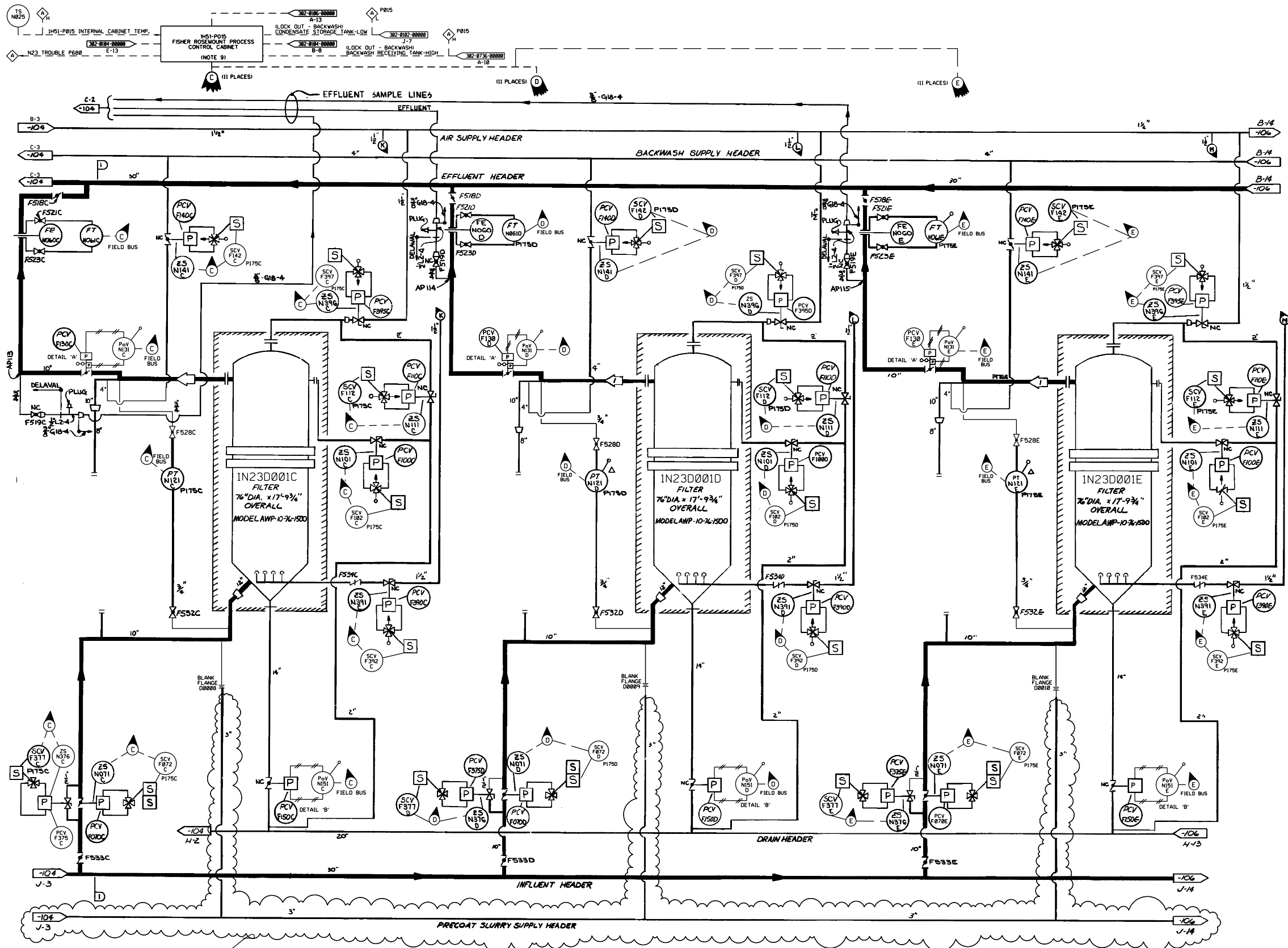

OPERATING DATA				
SEE NOTES 7, 8				
LINE	PSIG	GPM	°F	REMARKS
1	145-175	3,215	181.3	NORMAL
1	175	3633	148	MAX.

DESIGN DATA					
LINE	NORMAL		UPSET		REMARKS
	PSIG	°F	PSIG	°F	
1	250	185	250	148	

- REFERENCES:  
 302-0104-00000 CONDENSATE FILTRATION SYSTEM N23  
 302-0106-00000 CONDENSATE FILTRATION SYSTEM N23
- NOTES:  
 1. ALL PANELS & RACKS ARE PREFIXED IHS1, UNLESS OTHERWISE SPECIFIED.  
 2. DELETED  
 3. DELETED  
 4. DELETED  
 5. ALL FILTERS STAND ON FLOOR EL. 568'-6" (REF.).  
 6. ALL EXTERNAL PIPING EXCEPT SAMPLE TUBING IS CARBON STEEL.  
 7. PROCESS DATA SHOWN IN THE OPERATING DATA TABLE ON THIS SYSTEM DIAGRAM SHALL BE USED IN CONJUNCTION WITH THE DESIGN BASIS INFORMATION AND SHALL BE USED WITH CAUTION. IN GENERAL, THE OPERATING DATA (PRESSURES, TEMPERATURES, AND FLOWS) PROVIDED ON THIS DRAWING REPRESENTS THE MOST COMMON OPERATING CONDITION AND/OR SYSTEM MODE OF OPERATION AND/OR LINEUP. TO DETERMINE THE REQUIRED VALUES FOR A SPECIFIC OPERATING CONFIGURATION, THE APPROPRIATE DESIGN DOCUMENTS NEED TO BE REVIEWED.  
 8. OPERATING DATA IS TYPICALLY DERIVED FROM GE THERMAL KIT HEAT BALANCES. THE THERMAL KIT HEAT BALANCES ARE KEPT IN DESIGN INPUT RECORD (DIR) 237. OPERATING DATA SHOWN IS FOR RATED CONDITIONS APPLICABLE TO THE IMPLEMENTATION OF THE FOLLOWING PLANT CHANGES:  
 a.) POWER UPRATE TO 105% OF THE ORIGINAL DESIGN (REF.: TAP 81794)  
 b.) PARTIAL ARC ADMISSION (REF.: DCP 98-0050)  
 NOTE: PARTIAL ARC PARAMETER CHANGES (UP & DOWN) ARE SHOWN ONLY IF THEY ARE GREATER THAN 1% OF THE POWER UPRATE VALUES.  
 c.) LOW PRESSURE TURBINE ROTOR REPLACEMENT (REF.: ECP 04-0070).  
 9. THE CONTROL AND MONITORING OF EACH FILTER UNIT IS COMPLETED WITHIN THE FISHER ROSEMOUNT CONTROL PROCESSOR. ALL OPERATOR INPUT / OUTPUT INTERFACING IS CONDUCTED THROUGH A MONITOR AND KEYBOARD AT THE IHS1P015 PANEL.  
 10. FXXX - VALVE IDENTIFICATION NUMBER ("X" REPRESENTING LETTER DESIGNATION).

ABANDONED IN PLACE

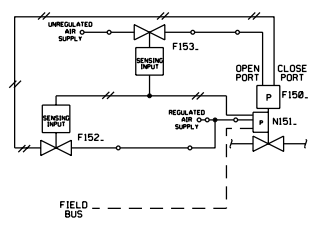
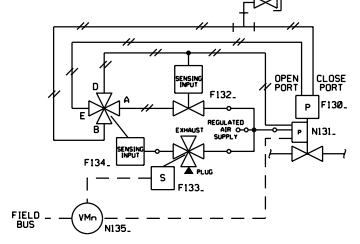

NOTE: SUFFIX "A" CORRELATES TO THE APPROPRIATE ALPHA DESIGNATION OF EACH FILTER.  
 NOTE: SUFFIX "B" CORRELATES TO THE APPROPRIATE ALPHA DESIGNATION OF EACH FILTER.

(Rev. 18 10/13)

**PERRY NUCLEAR POWER PLANT**  
 10 CENTER RD., PERRY, OHIO 44081

CONDENSATE FILTRATION SYSTEM

FIGURE 10.1-5 (SHEET 2 OF 3)  
 (DWG. D-302-0105-00000)

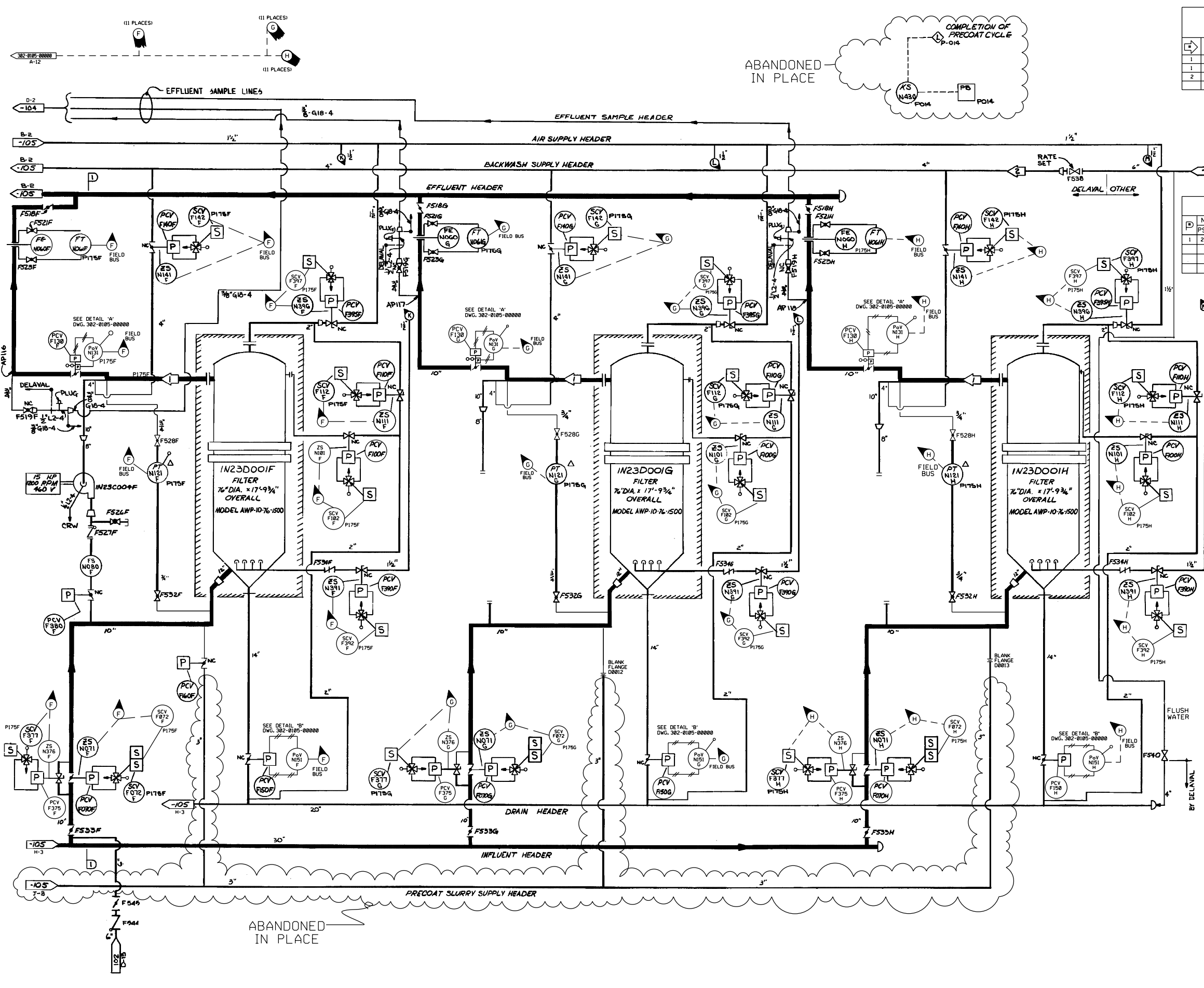

OPERATING DATA				
SEE NOTES 8, 9				
ID	PSIG	GPM	"F	REMARKS
1	145-175	3,215	101.3	NORMAL
1	250	3633	148	MAX.
2	30	479	105	INTERMITTENT (4.4 MIN.)

DESIGN DATA					
ID	NORMAL PSIG	UPSET PSIG	"F TIME	REMARKS	
1	250	105	250	140	

- REFERENCES:
- 302-0102-00000 CONDENSATE TRANSFER AND STORAGE SYSTEM P11
  - 302-0104-00000 CONDENSATE FILTRATION SYSTEM N23
  - 302-0105-00000 CONDENSATE FILTRATION SYSTEM N23
  - 302-0241-00000 SERVICE AND INSTRUMENT AIR SUPPLY P51 & P52
  - 302-0736-00000 LRW - TANKS AND PUMPS FOR BACKWASH SLURRY G50
  - 302-0771-00000 NUCLEAR SAMPLING SAMPLE P34

- NOTES:
1. ALL PANELS & RACKS ARE PREFIXED INSL, UNLESS OTHERWISE SPECIFIED.
  2. DELETED
  3. DELETED
  4. DELETED
  5. ALL FILTERS STAND ON FLOOR EL. 568'-6" (REF.).
  6. ALL EXTERNAL PIPING EXCEPT SAMPLE TUBING IS CARBON STEEL.
  7. DELETED
  8. PROCESS DATA SHOWN IN THE OPERATING DATA TABLE ON THIS SYSTEM DIAGRAM SHALL BE USED IN CONJUNCTION WITH THE DESIGN BASIS INFORMATION AND SHALL BE USED WITH CAUTION. IN GENERAL, THE OPERATING DATA (PRESSURES, TEMPERATURES, AND FLOWS) PROVIDED ON THIS DRAWING, REPRESENTS THE MOST COMMON OPERATING CONDITION, AND/OR SYSTEM MODE OF OPERATION AND/OR LINEUP. TO DETERMINE THE REQUIRED VALUES FOR A SPECIFIC OPERATING CONFIGURATION, THE APPROPRIATE DESIGN DOCUMENTS NEED TO BE REVIEWED.
  9. OPERATING DATA IS TYPICALLY DERIVED FROM GE THERMAL KIT HEAT BALANCES. THE THERMAL KIT HEAT BALANCES ARE KEPT IN DESIGN INPUT RECORD DCR 237. OPERATING DATA SHOWN IS FOR RATED CONDITIONS APPLICABLE TO THE IMPLEMENTATION OF THE FOLLOWING PLANT CHANGES:
    - a) POWER UPGRADE TO 105% OF THE ORIGINAL DESIGN (REF.: TAP 81794)
    - b) PARTIAL ARC ADMISSION (REF.: DCP 98-0050)
 NOTE: PARTIAL ARC PARAMETER CHANGES (UP & DOWN) ARE SHOWN ONLY IF THEY ARE GREATER THAN 1% OF THE POWER UPGRADE VALUES.
  - c) LOW PRESSURE TURBINE ROTOR REPLACEMENT (REF.: ECP 04-0070)

(Rev. 18 10/13)

**PERRY NUCLEAR POWER PLANT**  
10 CENTER RD., PERRY, OHIO 44081

CONDENSATE FILTRATION SYSTEM

FIGURE 10.1-5 (SHEET 3 OF 3)  
(DWG. D-302-0106-00000)

OPERATING DATA				
SEE NOTES 4, 5				
LINE NO.	PSIG	GPM	°F	REMARKS
1	175	22,502	181.3	
2	175	8,458	181.3	
3	110	22,502	181.3	

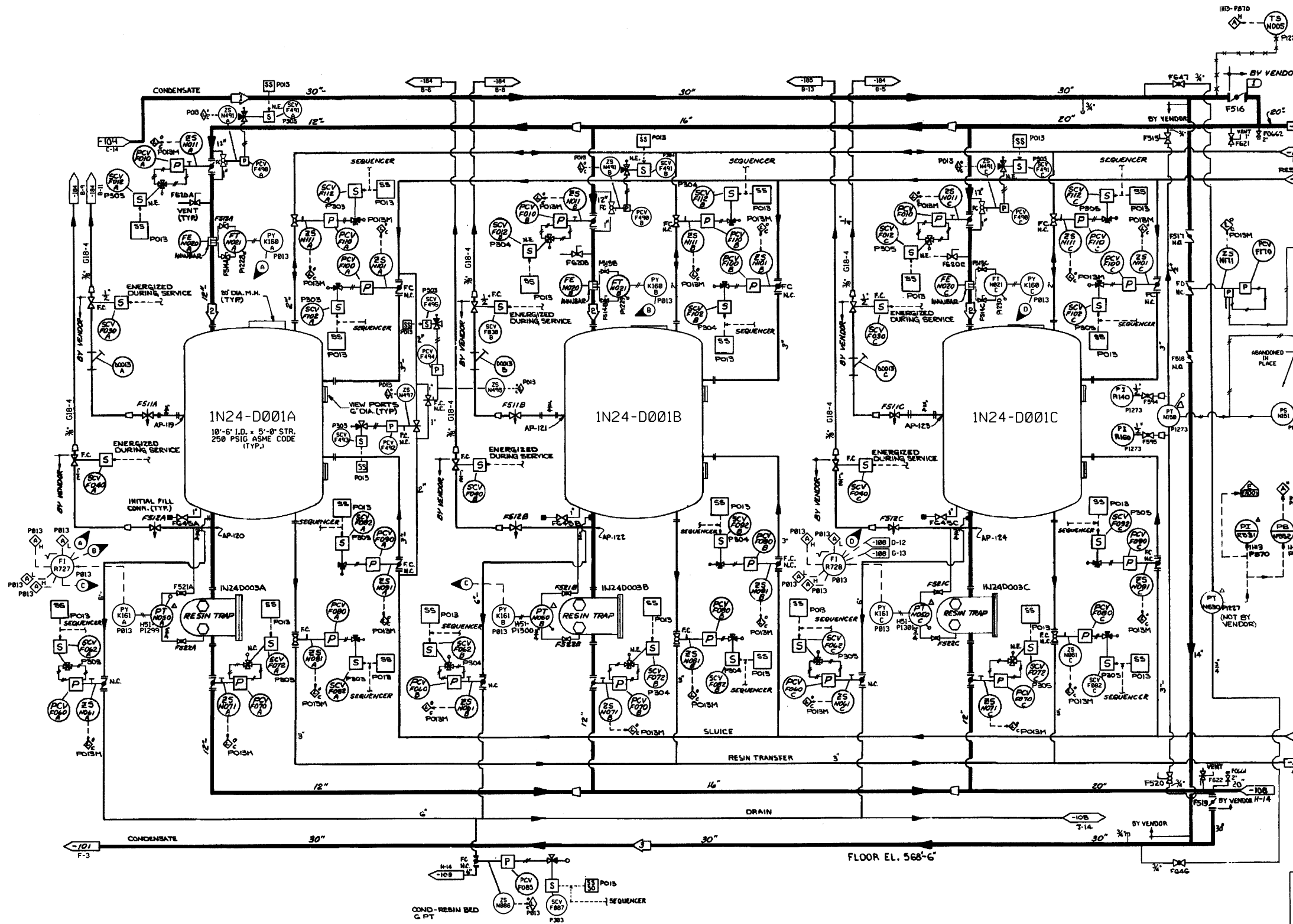

DESIGN DATA					
LINE NO.	NORMAL PSIG	UPSET PSIG	°F	TIME	REMARKS
1	250	185	250	148	
2	250	185	250	148	

- NOTES:
- ALL PANELS AND RACKS ARE PREFIXED IHS UNLESS OTHERWISE NOTED.
  - VALVE STATUS LIGHTS WITH SUFFIX 'M' ARE LOCATED ON IHS.
  - ALL ALARMS ARE ANNUNCIATED AS SYSTEM TROUBLE ON IHS.
  - PROCESS DATA SHOWN IN THE OPERATING DATA TABLE ON THIS SYSTEM DIAGRAM SHALL BE USED IN CONJUNCTION WITH THE DESIGN BASIS INFORMATION AND SHALL BE USED WITH CAUTION. IN GENERAL, THE OPERATING DATA (PRESSURES, TEMPERATURES, AND FLOWS) PROVIDED ON THIS DRAWING REPRESENTS THE MOST COMMON OPERATING CONDITION AND/OR SYSTEM MODE OF OPERATION AND/OR LINEUP. TO DETERMINE THE REQUIRED VALUES FOR A SPECIFIC OPERATING CONFIGURATION, THE APPROPRIATE DESIGN DOCUMENTS NEED TO BE REVIEWED.
  - OPERATING DATA IS TYPICALLY DERIVED FROM THERMAL KIT HEAT BALANCES. THE THERMAL KIT HEAT BALANCES ARE KEPT IN DESIGN INPUT RECORD (DIR) 237. OPERATING DATA SHOWN IS FOR RATED CONDITIONS APPLICABLE TO THE IMPLEMENTATION OF THE FOLLOWING PLANT CHANGES:
    - a) POWER UPRATE TO 105% OF THE ORIGINAL DESIGN (REF. 100-0174)
    - b) PARTIAL ARC ADMISSION (REF. DCP 98-0050)
    - NOTE: PARTIAL ARC PARAMETER CHANGES UP & DOWN ARE SHOWN ONLY IF THEY ARE GREATER THAN 1% OF THE POWER UPRATE VALUES.
    - c) LOW PRESSURE TURBINE ROTOR REPLACEMENT (REF. ECP 84-0070)
- REFERENCES:
- 302-0101-00000 CONDENSATE SYSTEM N01
  - 302-0104-00000 CONDENSATE FILTRATION SYSTEM N23
  - 302-0106-00000 CONDENSATE DEMINERALIZER SYSTEM N24
  - 302-0104-00000 TURBINE PLANT SAMPLING SYSTEM P33
  - 302-0105-00000 TURBINE PLANT SAMPLING SYSTEM P33

(REV. 19 10/2015)

**PERRY NUCLEAR POWER PLANT**  
 10 CENTER RD., PERRY, OHIO 44081

CONDENSATE  
 DEMINERALIZER SYSTEM  
 FIGURE 10.1-6 (SHEET 1 OF 4)  
 (DWG. D-302-0107-00000)

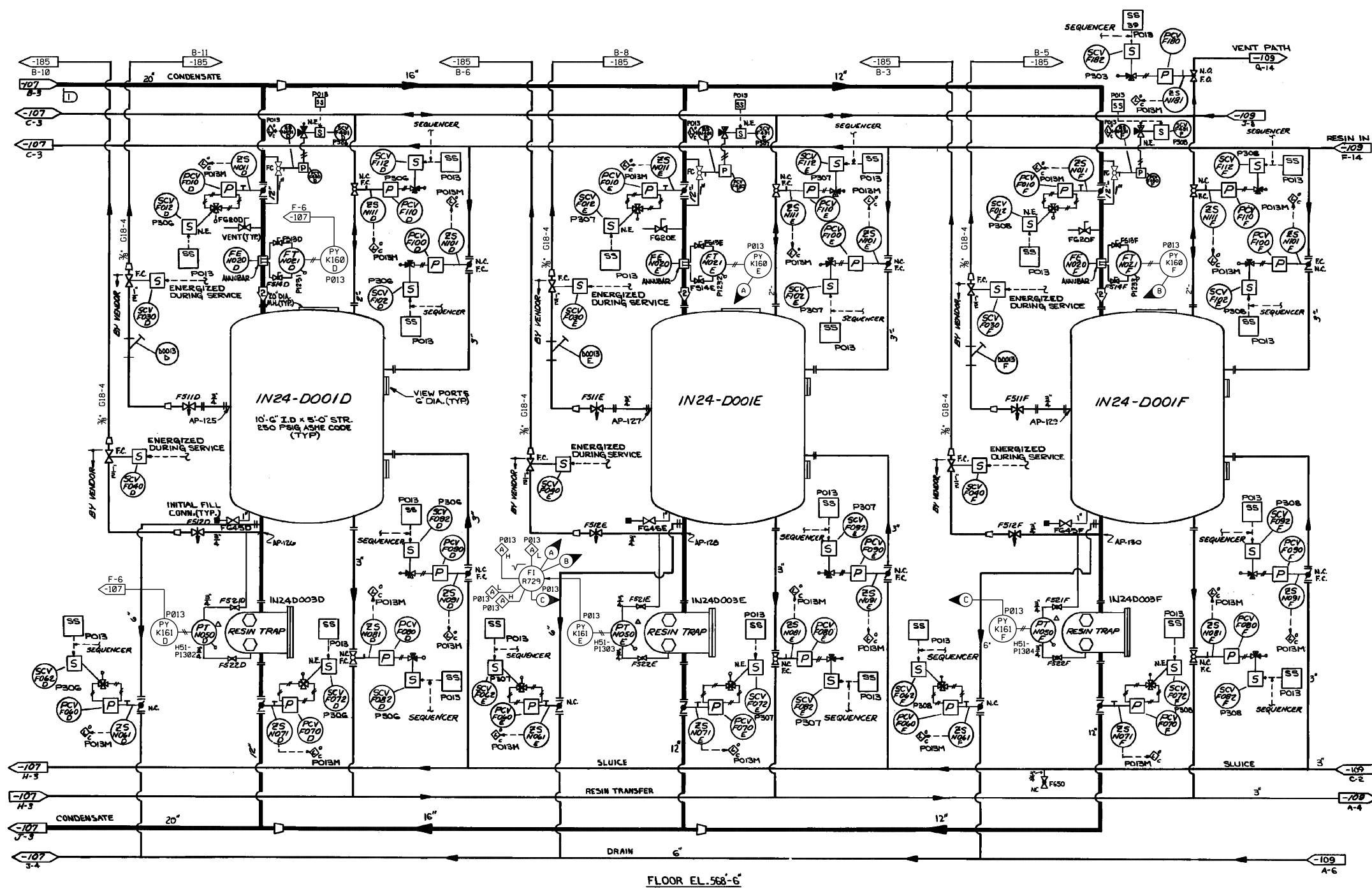

OPERATING DATA			
SEE NOTE 1			
PSIG	GPM	°F	REMARKS
2	175	8/4,500	101.3

DESIGN DATA					
PSIG	°F	PSIG	°F	TIME	REMARKS
1	250	185	250	140	

- REFERENCES:
- 302-0107-00000 CONDENSATE DEMINERALIZER SYSTEM N24
  - 302-0109-00000 CONDENSATE DEMINERALIZER SYSTEM N24
  - 302-0105-00000 TURBINE PLANT SAMPLING SYSTEM P33

- NOTES:
- PROCESS DATA SHOWN IN THE OPERATING DATA TABLE ON THIS SYSTEM DIAGRAM SHALL BE USED IN CONJUNCTION WITH THE DESIGN BASIS INFORMATION AND SHALL BE USED WITH CAUTION. IN GENERAL, THE OPERATING DATA (PRESSURES, TEMPERATURES, AND FLOWS) PROVIDED ON THIS DRAWING REPRESENTS THE MOST COMMON OPERATING CONDITION AND/OR SYSTEM MODE OF OPERATION AND/OR LINEUP. TO DETERMINE THE REQUIRED VALUES FOR A SPECIFIC OPERATING CONFIGURATION, THE APPROPRIATE DESIGN DOCUMENTS NEED TO BE REVIEWED.
  - OPERATING DATA IS TYPICALLY DERIVED FROM GE THERMAL KIT HEAT BALANCES. THE THERMAL KIT HEAT BALANCES ARE KEPT IN DESIGN INPUT RECORD (DIR) 237. OPERATING DATA SHOWN IS FOR RATED CONDITIONS APPLICABLE TO THE IMPLEMENTATION OF THE FOLLOWING PLANT CHANGES:
    - LOW PRESSURE TURBINE ROTOR REPLACEMENT (REF. EEP 04-0070)

(Rev. 18 10/13)

**PERRY NUCLEAR POWER PLANT**  
 10 CENTER RD., PERRY, OHIO 44081

CONDENSATE DEMINERALIZER SYSTEM

FIGURE 10.1-6 (SHEET 2 OF 4)  
 (DWG. D-302-0108-00000)

OPERATING DATA

SEE NOTE 4

PSIG	GPM	F	REMARKS
1	50	1453	100 JG
2	60	1400	140 JG

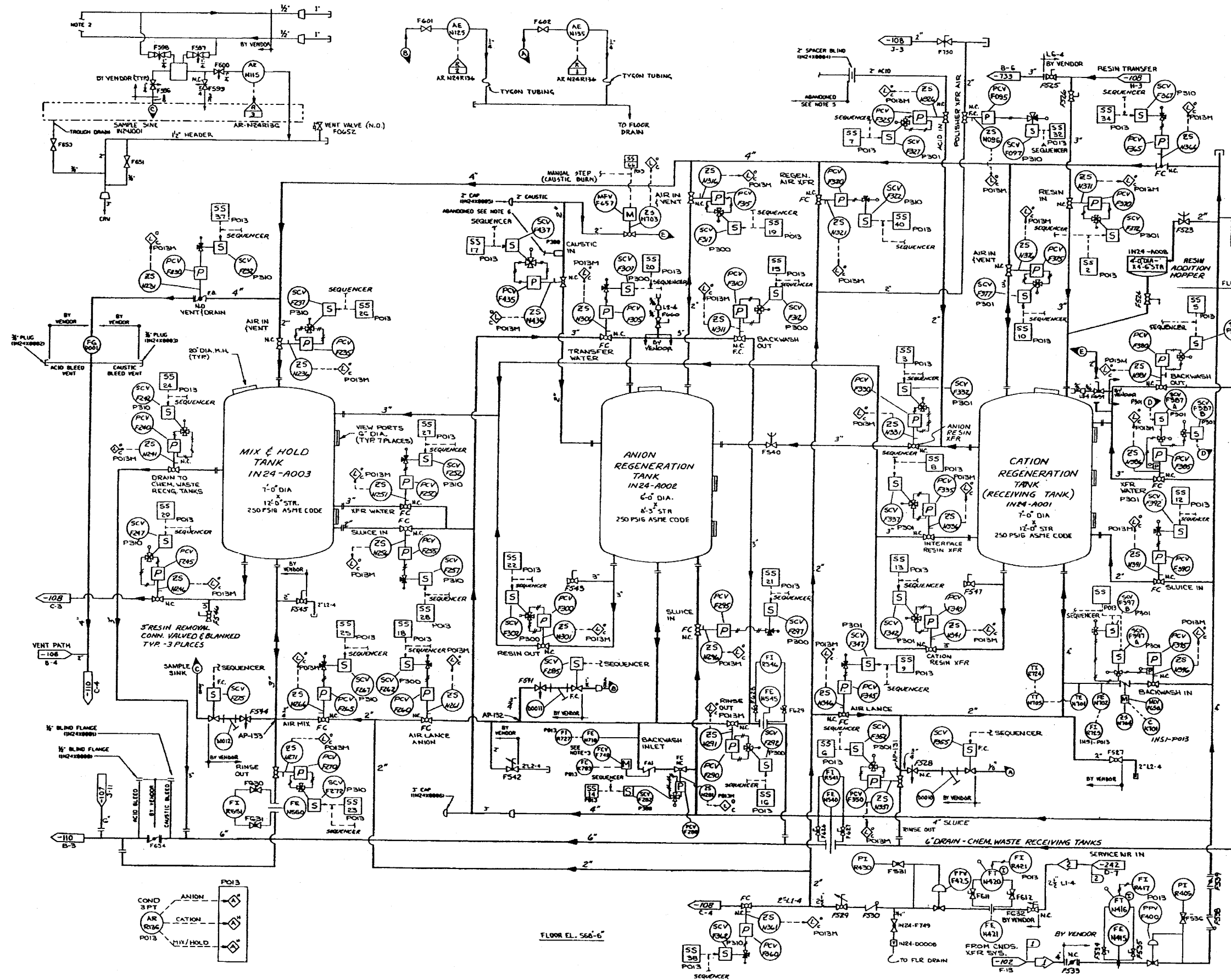

DESIGN DATA

INSTRUMENT	PSIG	LIQSET	TYPE	REMARKS
1	150	PS		
2	125	ANS		

- NOTES:
- FOR SEQUENCE TIMERS IN24R700 THROUGH IN24R723. SEE DRAWING 282-0145-00000.
  - SAMPLE COOLER (M24-1000) IS ABANDONED IN PLACE FOR IN24R24 BED AND EFFLUENT SAMPLES.
  - INSTRUMENTS LEFT ENCEPILED, VALVE & INSTRUMENTS ABANDONED IN PLACE #1727, FC N710 & FC R702. REF. DCP 100220A.
  - PROCESS DATA SHOWN IN THE OPERATING DATA TABLE ON THIS SYSTEM DIAGRAM SHALL BE USED IN CONJUNCTION WITH THE DESIGN BASIS INFORMATION AND SHALL BE USED WITH CAUTION. IN GENERAL, THE OPERATING DATA PRESSURES, TEMPERATURES AND FLOWS PROVIDED ON THIS DRAWING REPRESENTS THE MOST COMMON OPERATING CONDITION AND/OR SYSTEM MODE OF OPERATION AND/OR LINEUP. TO DETERMINE THE REQUIRED VALUES FOR A SPECIFIC OPERATING CONFIGURATION, THE APPROPRIATE DESIGN DOCUMENTS NEED TO BE REVIEWED.
  - ALL PIPING/TUBING THIS SIDE OF ISOLATION IS ABANDONED. FOR DETAILS, SEE TECHNICAL ASSIGNMENT FILE B1777.
  - INSTRUMENT AE-4225 WAS INADVERTENTLY SHOWN ON Dwg. 282-0110-00000. HOWEVER, IT IS NOW ABANDONED IN PLACE. FOR DETAILS, SEE TECHNICAL ASSIGNMENT FILE B1777.

- REFERENCES:
- 282-0182-00000 CONDENSATE TRANSFER AND STORAGE SYSTEM P11
  - 282-0180-00000 CONDENSATE DEMINERALIZER SYSTEM M24
  - 282-0110-00000 CONDENSATE DEMINERALIZER SYSTEM M24
  - 282-0241-00000 SERVICE AND INSTRUMENT AIR SUPPLY P51 AND P52
  - 282-0723-00000 CHEMICAL WASTE TANKS AND WASTE EVAPORATOR / CONDENSER C21
  - 282-0242-00000 SERVICE AIR DISTRIBUTION SYSTEM P51

(Rev. 15 10/07)

**PERRY NUCLEAR POWER PLANT**

Condensate Demineralizer System

Figure 10.1-6 (Sheet 3 of 4)

(Dwg. D-302-109)



OPERATING DATA  
SEE NOTE 2

ID	PSIG	GPM	F	By	REMARKS
1	GD	200	120		
2	GD	200	120		

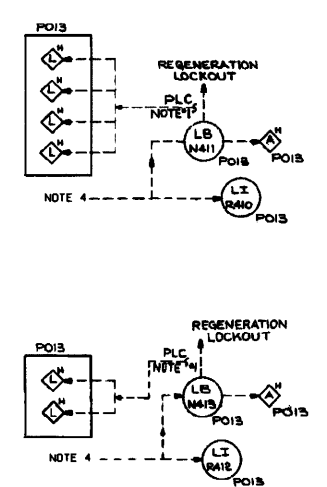
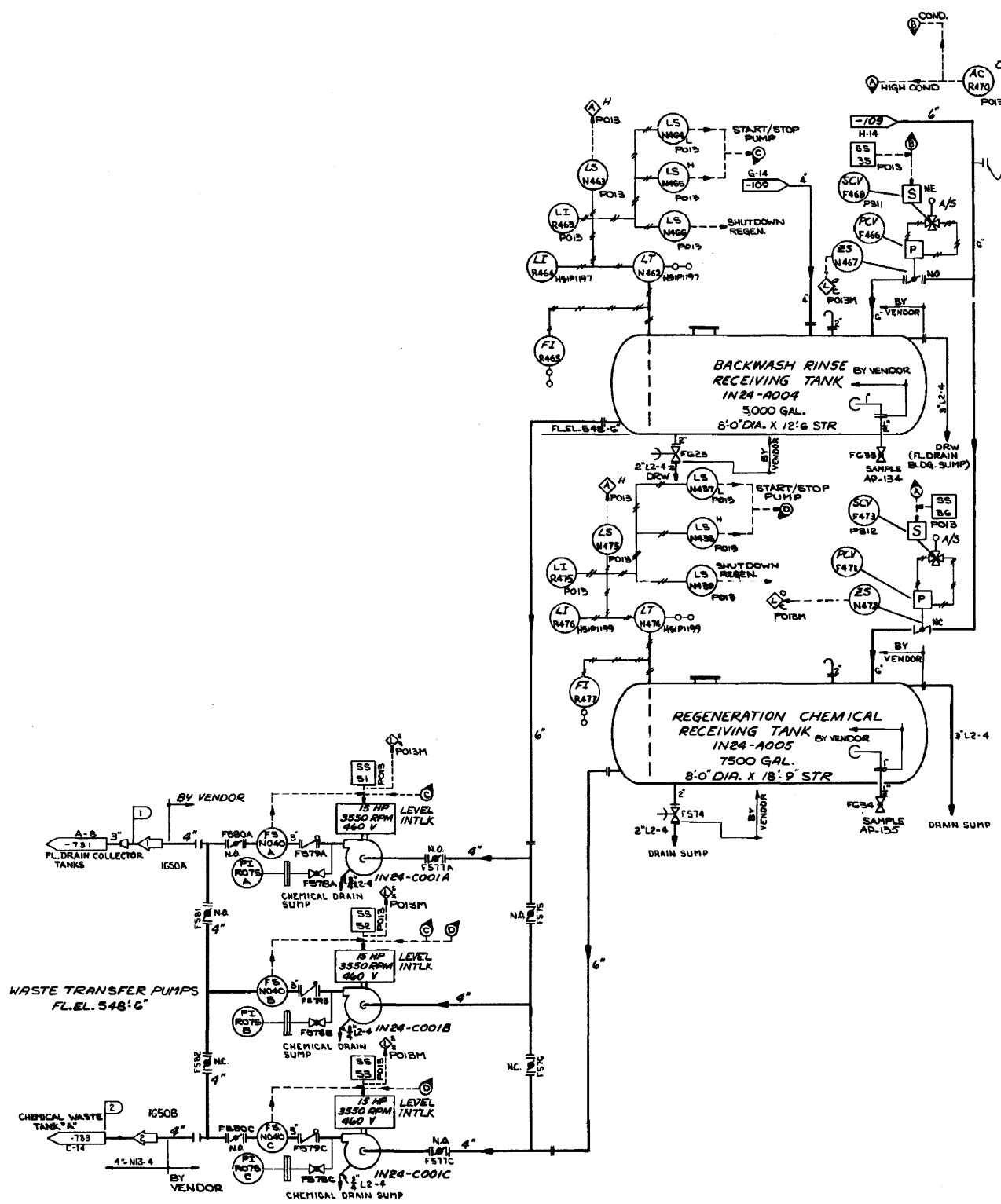

DESIGN DATA

ID	PSIG	GPM	F	By	REMARKS
1	GD	180	80	170	
2	GD	180	80	180	

- NOTES:
- 0-58 LIQUID RADWASTE SYSTEM PLC IS INACTIVE.
  - PROCESS DATA SHOWN IN THE OPERATING DATA TABLE ON THIS SYSTEM DIAGRAM SHALL BE USED IN CONJUNCTION WITH THE DESIGN BASIS INFORMATION AND SHALL BE USED WITH CAUTION. IN GENERAL, THE OPERATING DATA (PRESSURES, TEMPERATURES, AND FLOWS) PROVIDED ON THIS DRAWING, REPRESENTS THE MOST COMMON OPERATING CONDITION AND/OR SYSTEM MODE OF OPERATION AND/OR LINEUP, TO DETERMINE THE REQUIRED VALUES FOR A SPECIFIC OPERATING CONFIGURATION, THE APPROPRIATE DESIGN DOCUMENTS NEED TO BE REVIEWED.
  - CONDUCTIVITY CELL PY-IN24A049 REMOVED FROM SYSTEM. CONDUCTIVITY REC. PY-IN24A049 SPARED IN COND. STO. CTRL. CONTROL PANEL. UIC9P003.
  - ANALOG SIGNALS FROM 0-58 LIQUID RADWASTE SYSTEM ARE INACTIVE.

- REFERENCES:
- 302-0109-00000 CONDENSATE DEMINERALIZER SYSTEM H24
  - 302-0731-00000 LRW - FLOOR DRAIN COLLECTOR TANKS AND WASTE COLLECTOR TANKS 030
  - 302-0733-00000 LRW - CHEMICAL WASTE TANKS AND SPENT RESIN TRANSFER PUMPS 030

(REV. 19 10/2015)

PERRY NUCLEAR POWER PLANT  
10 CENTER RD., PERRY, OHIO 44081

CONDENSATE  
DEMINERALIZER SYSTEM  
FIGURE 10.1-6 (SHEET 4 OF 4)  
(DWG. D-302-0110-00000)

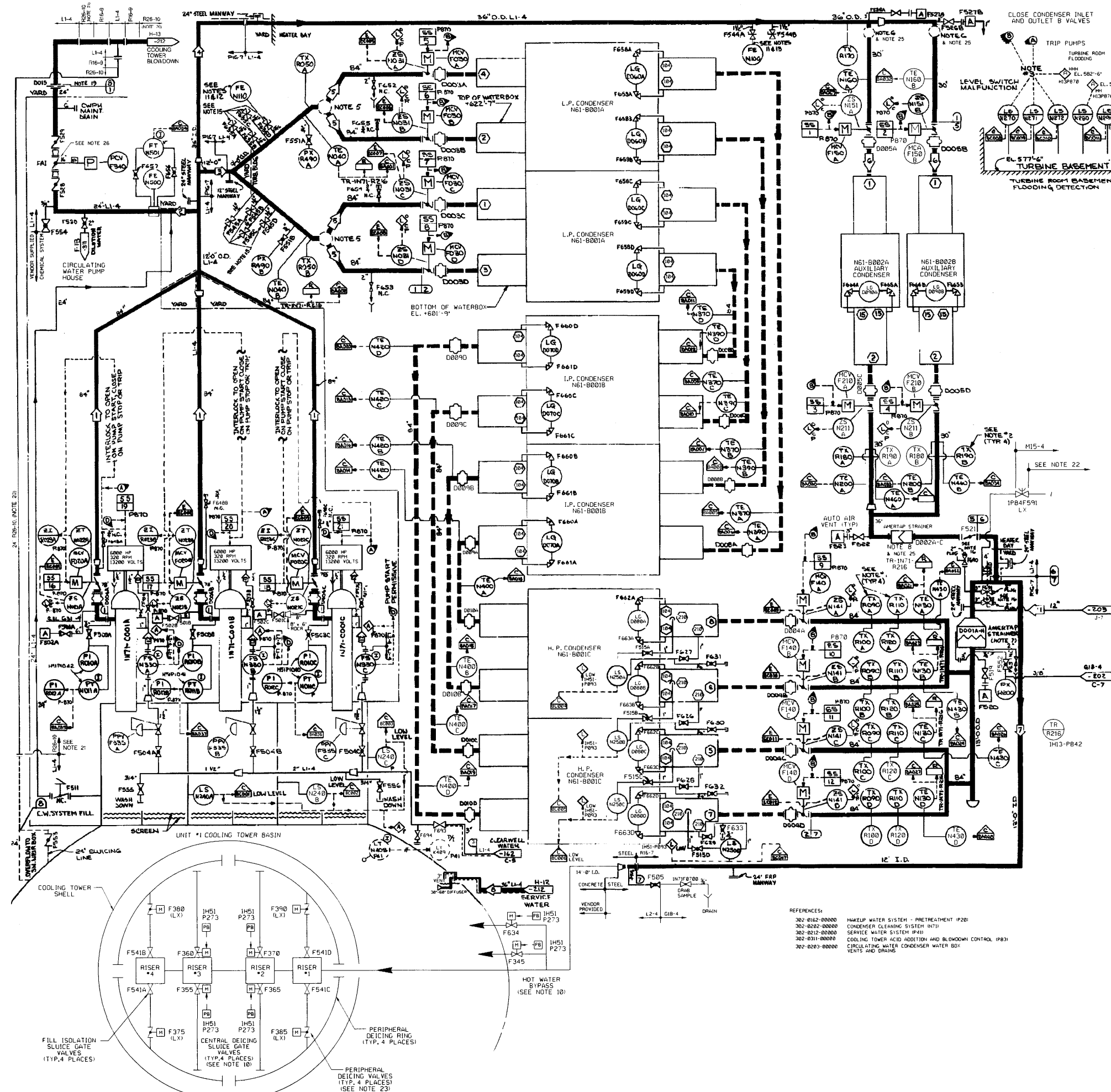

OPERATING DATA \*  
SEE NOTE 24

PSIG	GPM	"F	REMARKS
1	44	192,124	48" TO 96"
2	56	10,300	48" TO 96"
3	52	566,073	48" TO 96"
4	50	536,147	48" TO 96"
5	52	288,073	48" TO 96"
6	43	14,353	48" TO 96"
7	34	36,804	36" FRP LOW POINT
8	31	540,101	144" STEEL FRP
9	30	570,093	36" X 144" TEE 4
10	27	570,093	HARD FRP TO TOWER CONCRETE
11	5	25,980	15,778 GPM - FEB.
12	48	3,000	48" TO 120"
13	25	23	35" TO 81.5"
14	25	3	35" TO 81.5"

\* OPERATING DATA IS BASED ON CASE 1 OF CALCULATION  
N71-8001 PUMPS, NORMAL SYSTEM LINEUP.

DESIGN DATA

PSIG	"F	PSIG	"F	TIME	REMARKS
1	58	96	83	96	CLX UPSET AT PUMP SHUTOFF
2	52	128	78	128	CLX UPSET AT PUMP SHUTOFF
3	100	80	125	80	CLX CLEARWELL WATER FROM P28 SYSTEM
4	44	108	70	108	CLX UPSET AT PUMP SHUTOFF
5	23	100	23	100	CLX
6	35	128	35	128	CLX
7	5	96	5	96	CLX 13988 GPM MAXI SEE NOTE 19

\*\* DESIGN CONDITIONS APPLICABLE TO NORMAL SYSTEM OPERATION ARE BASED ON CASE 2 OF CALCULATION  
N71-8001 PUMPS, ONE ISOLATED CONDENSER TRAIL.  
\*\*\* BOUNDING (WORST CASE) DESIGN CONDITIONS ARE INDICATED IN THE UPSET DESIGN DATA COLUMN  
PUMPS AT SHUT OFF HEAD CONDITIONS.

- NOTES:
- FOUR TX'S LOCATED RADially ON THE SAME PLANE.
  - TWO TX'S LOCATED RADially ON THE SAME PLANE.
  - TWO OUT OF THREE.
  - DIFFUSER PIPE.
  - AMERTAP BALL INJECTION. SEE DWG. 302-0202-00000 ID-51.
  - AMERTAP BALL INJECTION. SEE DWG. 302-0202-00000 IG-4 AND D-9.
  - AMERTAP BALL EXTRACTION. SEE DWG. 302-0202-00000 ID-8 AND D-9.
  - AMERTAP BALL EXTRACTION. SEE DWG. 302-0202-00000 IJ-13.
  - ALL INSTRUMENTS AND CONTROLS DESIGNATED P- TO BE MOUNTED ON PANEL H33P870, UNLESS OTHERWISE NOTED.
  - EACH VALVE HAS A PAIR OF LIMIT SWITCHES FOR OPERATING STATUS LIGHTS ON PANEL H33P870. LIMIT SWITCHES ARE NUMBERED "XXXX+J", WHERE "XXX" IS THE NUMERICAL PORTION OF THE VALVE NUMBER.
  - THE PILOT TUBES, FOR USE WITH TEST MONITORS ARE USED FOR FLOW TESTING IN BOTH UNITS AND ARE NOT PERMANENTLY INSTALLED. THEY HAVE PREFIX DNT1.
  - TYPICAL AT VALVES F625A, F635B, F625C, F635D, F654A, F654B, F654C AND F654D.
  - TYPICAL AT VALVES F654A AND F654B.
  - FOR CIRCULATING WATER PUMP AND MOTOR SUPERVISORY THERMOCOUPLES. SEE DWG. 808-0200-00000.
  - F654A, F654B, F654C, F654D, F635A, F635B, F635C AND F635D CORPORATION COCKS ARE INSTALLED WITH PLUGS TO PREVENT LEAKS.
  - PENETRATION THRU 12" DIA. PIPE WALL IS 2" DIA. USED FOR PILOT TUBES.
  - AUTO VENTS INSTALLED IN THIS SYSTEM THAT DO NOT HAVE AN ASSOCIATED HARD PIPE DISCHARGE LINE MAY UTILIZE A FLEXIBLE (17-GON) RUBBER HOSE, IF DESIRED, TO DISCHARGE TO A CONVENIENT FLOOR DRAIN.
  - DELETED.
  - VERTICAL CARBON STEEL PIPING L1-4 DOWNSTREAM OF RD-0001B IS SUBJECT TO VACUUM CONDITIONS OF 9.9 PSIA MINIMUM.
  - EXISTING FRP PIPE HAS BEEN LINED WITH CURED-IN-PLACE PIPE LINE SPEC. RR26-10L. INVERSION POINT FOR INSTALLATION OF CIPR UTILIZES STEEL PIPE TEE AND FLANGES L1-4 AND NEW FRP FLANGES PIPE 100-9.
  - THE CIPP WILL EXTEND INTO THE STEEL PIPE WHERE END SEALS ARE MADE.
  - ALL PIPING/TUBING ON THIS SIDE OF ISOLATION IS ABANDONED. FOR DETAILS, SEE TECHNICAL ASSIGNMENT FILE R177.
  - PERIPHERAL DEICE PIPING DOWNSTREAM OF ISOLATION VALVES HAVE BEEN ABANDONED IN PLACE (REFERENCE SHRF 97-5098).
  - PROCESS DATA SHOWN IN THE OPERATING DATA TABLE ON THIS SYSTEM DIAGRAM IS APPROPRIATE AND SHALL BE USED IN CONJUNCTION WITH THE DESIGN BASIS INFORMATION AND SHALL BE USED WITH CAUTION. IN GENERAL, THE OPERATING DATA (PRESSURES, TEMPERATURES AND FLOWS PROVIDED ON THIS DRAWING, REPRESENTS THE MOST COMMON OPERATING CONDITION AND/OR SYSTEM MODE OF OPERATION AND/OR LINEUP. TO DETERMINE THE REQUIRED VALUES FOR A SPECIFIC OPERATING CONFIGURATION, THE APPROPRIATE DESIGN DOCUMENTS NEED TO BE REVIEWED. REFER TO THE N71 SYSTEM PHOTO-FLO MODEL CONTAINED IN CALCULATION N71-801.
  - AUXILIARY CONDENSER AMERTAP NO LONGER USED. SEE DEC 89-5098 AND TAG 8177.
  - VALVE INT8103D WILL BE CONTROLLED MANUALLY. THE PRESSURE ACTIVATED CONTROLS HAVE BEEN DISABLED.

- REFERENCES:
- 302-0102-00000 MAKEUP WATER SYSTEM - PRE-TREATMENT (P28)
  - 302-0202-00000 CONDENSER CLEANING SYSTEM (N71)
  - 302-0212-00000 SERVICE WATER SYSTEM (P41)
  - 302-0311-00000 COOLING TOWER WATER ADDITION AND BLOWDOWN CONTROL (P83)
  - 302-0203-00000 CIRCULATING WATER CONDENSER WATER BODY VENTS AND DRAINS

(REV. 19 10/2015)

PERRY NUCLEAR POWER PLANT  
10 CENTER RD., PERRY, OHIO 44081

CIRCULATING WATER SYSTEM  
FIGURE 10.1-7  
(DWG. D-302-0201-00000)

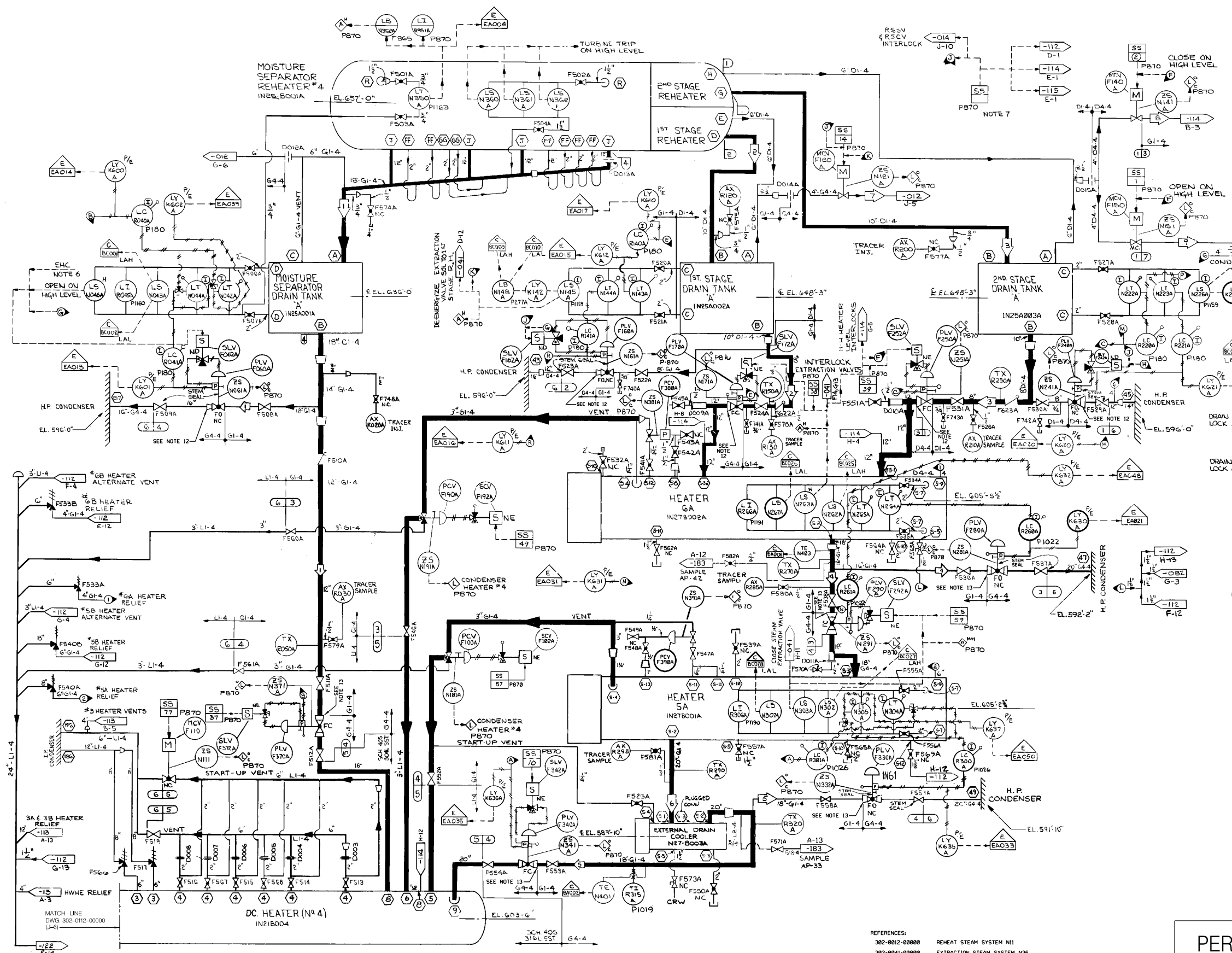

OPERATING DATA (RATED)  
SEE NOTES 10, 11

	PSIA	LB/HR	°F	REMARKS
1	191	421,716	378	
2	552	178,058	477	
3	966	159,496	548	
4	344	1,143,886	382	
5	185	1,526,419	339	
6	185	1,526,419	339	
7	552	17,885	477	
8	362	15,958	435	
9	529	15,453	474	

DESIGN DATA

	NORMAL	UPSET	REMARKS
1	1258	575	NA NA NA
2	600	492	NA NA NA
3	400	458	NA NA NA
4	280	385	NA NA NA
5	120	358	NA NA NA
6	50	388	NA NA NA
7	550	500	NA NA NA

- NOTES:
- VENT DRIFTS ON HEATER 5 AND 6 ARE INTERNAL.
  - FEEDWATER HEATERS SHOWN ON FOSTER-WHEELER DRAWINGS.
  - DC HEATER SHOWN ON CHICAGO HEATER DWG. D-3536.
  - MANUAL HEATER DRAINS ARE PIPED TO CONDENSER.
  - ALL PANEL AND RACKS ARE PREFIXED I#13, UNLESS OTHERWISE NOTED.
  - SIGNAL PROVIDED BY EHC TO INTERLOCK VALVES OPENING DURING PREWARMING OPERATION.
  - ONE CONTROL SWITCH IS PROVIDED FOR ALL 14 MSR REHEATER STEAM FEED AND ASSOCIATED DRAIN SYSTEMS. THIS CONTROL FUNCTIONS TO PREVENT LOSS OF BLANKETING STEAM WHEN STEAM BLANKETING IS BEING APPLIED.
  - LOCK, PANELS AND RACKS P180, P181, P182, P183, P184, P185, P186, P187, P188, P189, P190, P191, P192, P193, P194, P195, P196, P197, P198, P199, P200, P201, P202, P203, P204, P205, P206, P207, P208, P209, P210, P211, P212, P213, P214, P215, P216, P217, P218, P219, P220, P221, P222, P223, P224, P225, P226, P227, P228, P229, P230, P231, P232, P233, P234, P235, P236, P237, P238, P239, P240, P241, P242, P243, P244, P245, P246, P247, P248, P249, P250, P251, P252, P253, P254, P255, P256, P257, P258, P259, P260, P261, P262, P263, P264, P265, P266, P267, P268, P269, P270, P271, P272, P273, P274, P275, P276, P277, P278, P279, P280, P281, P282, P283, P284, P285, P286, P287, P288, P289, P290, P291, P292, P293, P294, P295, P296, P297, P298, P299, P300, P301, P302, P303, P304, P305, P306, P307, P308, P309, P310, P311, P312, P313, P314, P315, P316, P317, P318, P319, P320, P321, P322, P323, P324, P325, P326, P327, P328, P329, P330, P331, P332, P333, P334, P335, P336, P337, P338, P339, P340, P341, P342, P343, P344, P345, P346, P347, P348, P349, P350, P351, P352, P353, P354, P355, P356, P357, P358, P359, P360, P361, P362, P363, P364, P365, P366, P367, P368, P369, P370, P371, P372, P373, P374, P375, P376, P377, P378, P379, P380, P381, P382, P383, P384, P385, P386, P387, P388, P389, P390, P391, P392, P393, P394, P395, P396, P397, P398, P399, P400, P401, P402, P403, P404, P405, P406, P407, P408, P409, P410, P411, P412, P413, P414, P415, P416, P417, P418, P419, P420, P421, P422, P423, P424, P425, P426, P427, P428, P429, P430, P431, P432, P433, P434, P435, P436, P437, P438, P439, P440, P441, P442, P443, P444, P445, P446, P447, P448, P449, P450, P451, P452, P453, P454, P455, P456, P457, P458, P459, P460, P461, P462, P463, P464, P465, P466, P467, P468, P469, P470, P471, P472, P473, P474, P475, P476, P477, P478, P479, P480, P481, P482, P483, P484, P485, P486, P487, P488, P489, P490, P491, P492, P493, P494, P495, P496, P497, P498, P499, P500, P501, P502, P503, P504, P505, P506, P507, P508, P509, P510, P511, P512, P513, P514, P515, P516, P517, P518, P519, P520, P521, P522, P523, P524, P525, P526, P527, P528, P529, P530, P531, P532, P533, P534, P535, P536, P537, P538, P539, P540, P541, P542, P543, P544, P545, P546, P547, P548, P549, P550, P551, P552, P553, P554, P555, P556, P557, P558, P559, P560, P561, P562, P563, P564, P565, P566, P567, P568, P569, P570, P571, P572, P573, P574, P575, P576, P577, P578, P579, P580, P581, P582, P583, P584, P585, P586, P587, P588, P589, P590, P591, P592, P593, P594, P595, P596, P597, P598, P599, P600, P601, P602, P603, P604, P605, P606, P607, P608, P609, P610, P611, P612, P613, P614, P615, P616, P617, P618, P619, P620, P621, P622, P623, P624, P625, P626, P627, P628, P629, P630, P631, P632, P633, P634, P635, P636, P637, P638, P639, P640, P641, P642, P643, P644, P645, P646, P647, P648, P649, P650, P651, P652, P653, P654, P655, P656, P657, P658, P659, P660, P661, P662, P663, P664, P665, P666, P667, P668, P669, P670, P671, P672, P673, P674, P675, P676, P677, P678, P679, P680, P681, P682, P683, P684, P685, P686, P687, P688, P689, P690, P691, P692, P693, P694, P695, P696, P697, P698, P699, P700, P701, P702, P703, P704, P705, P706, P707, P708, P709, P710, P711, P712, P713, P714, P715, P716, P717, P718, P719, P720, P721, P722, P723, P724, P725, P726, P727, P728, P729, P730, P731, P732, P733, P734, P735, P736, P737, P738, P739, P740, P741, P742, P743, P744, P745, P746, P747, P748, P749, P750, P751, P752, P753, P754, P755, P756, P757, P758, P759, P760, P761, P762, P763, P764, P765, P766, P767, P768, P769, P770, P771, P772, P773, P774, P775, P776, P777, P778, P779, P780, P781, P782, P783, P784, P785, P786, P787, P788, P789, P790, P791, P792, P793, P794, P795, P796, P797, P798, P799, P800, P801, P802, P803, P804, P805, P806, P807, P808, P809, P810, P811, P812, P813, P814, P815, P816, P817, P818, P819, P820, P821, P822, P823, P824, P825, P826, P827, P828, P829, P830, P831, P832, P833, P834, P835, P836, P837, P838, P839, P840, P841, P842, P843, P844, P845, P846, P847, P848, P849, P850, P851, P852, P853, P854, P855, P856, P857, P858, P859, P860, P861, P862, P863, P864, P865, P866, P867, P868, P869, P870, P871, P872, P873, P874, P875, P876, P877, P878, P879, P880, P881, P882, P883, P884, P885, P886, P887, P888, P889, P890, P891, P892, P893, P894, P895, P896, P897, P898, P899, P900, P901, P902, P903, P904, P905, P906, P907, P908, P909, P910, P911, P912, P913, P914, P915, P916, P917, P918, P919, P920, P921, P922, P923, P924, P925, P926, P927, P928, P929, P930, P931, P932, P933, P934, P935, P936, P937, P938, P939, P940, P941, P942, P943, P944, P945, P946, P947, P948, P949, P950, P951, P952, P953, P954, P955, P956, P957, P958, P959, P960, P961, P962, P963, P964, P965, P966, P967, P968, P969, P970, P971, P972, P973, P974, P975, P976, P977, P978, P979, P980, P981, P982, P983, P984, P985, P986, P987, P988, P989, P990, P991, P992, P993, P994, P995, P996, P997, P998, P999, P1000.

- REFERENCES:
- 302-0012-00000 REHEAT STEAM SYSTEM N11
  - 302-0041-00000 EXTRACTION STEAM SYSTEM N36
  - 302-0112-00000 HIGH PRESSURE HEATER DRAINS AND VENTS 'B' SYSTEM N25
  - 302-0113-00000 LOW PRESSURE HEATER DRAINS AND VENTS SYSTEM N26
  - 302-0114-00000 HIGH PRESSURE HEATER DRAINS AND VENTS 'A' SYSTEM N25
  - 302-0122-00000 MAIN, REHEAT, EXTRACTION, AND MISCELLANEOUS DRAINS SYSTEM N22
  - 302-0183-00000 TURBINE PLANT SAMPLING SYSTEM P33
  - 802-0009-00000 REACTOR - TURBINE GENERATOR TRIP DIAGRAM
  - 302-0151-00000 CONDENSATE SEAL SYSTEM P12
  - 302-0014-00000 REHEATER HEATING STEAM SYSTEM N11
  - 302-0115-00000 HIGH PRESSURE HEATER DRAINS AND VENTS 'B' SYSTEM N25
  - 302-0082-00000 FEEDWATER SYSTEM N27

(REV. 21 10/2019)

**PERRY NUCLEAR POWER PLANT**  
10 CENTER RD., PERRY, OHIO 44081

**HIGH PRESSURE HEATER DRAINS AND VENTS**  
FIGURE 10.1-8 (SHEET 1 OF 4)  
(DWG. D-302-0111-00000)

OPERATING DATA (RATED)				
SEE NOTES 8, 9				
#	PSIA	LB/HR	'F	REMARKS
1	191	421,716	378	
2	552	178,858	477	
3	966	159,496	548	
4	344	1,143,886	382	
5	185	1,526,419	339	
6	185	1,526,419	339	
7	552	17,885	477	
8	363	15,950	435	
9	529	15,453	474	

DESIGN DATA					
#	NORMAL	UPSET	TIME	REMARKS	
D	PSIG	'F	PSIG	'F	
1	1250	575	NA	NA	
2	680	492	NA	NA	
3	400	450	NA	NA	
4	200	385	NA	NA	
5	120	350	NA	NA	
6	50	388	NA	NA	
7	550	500	NA	NA	

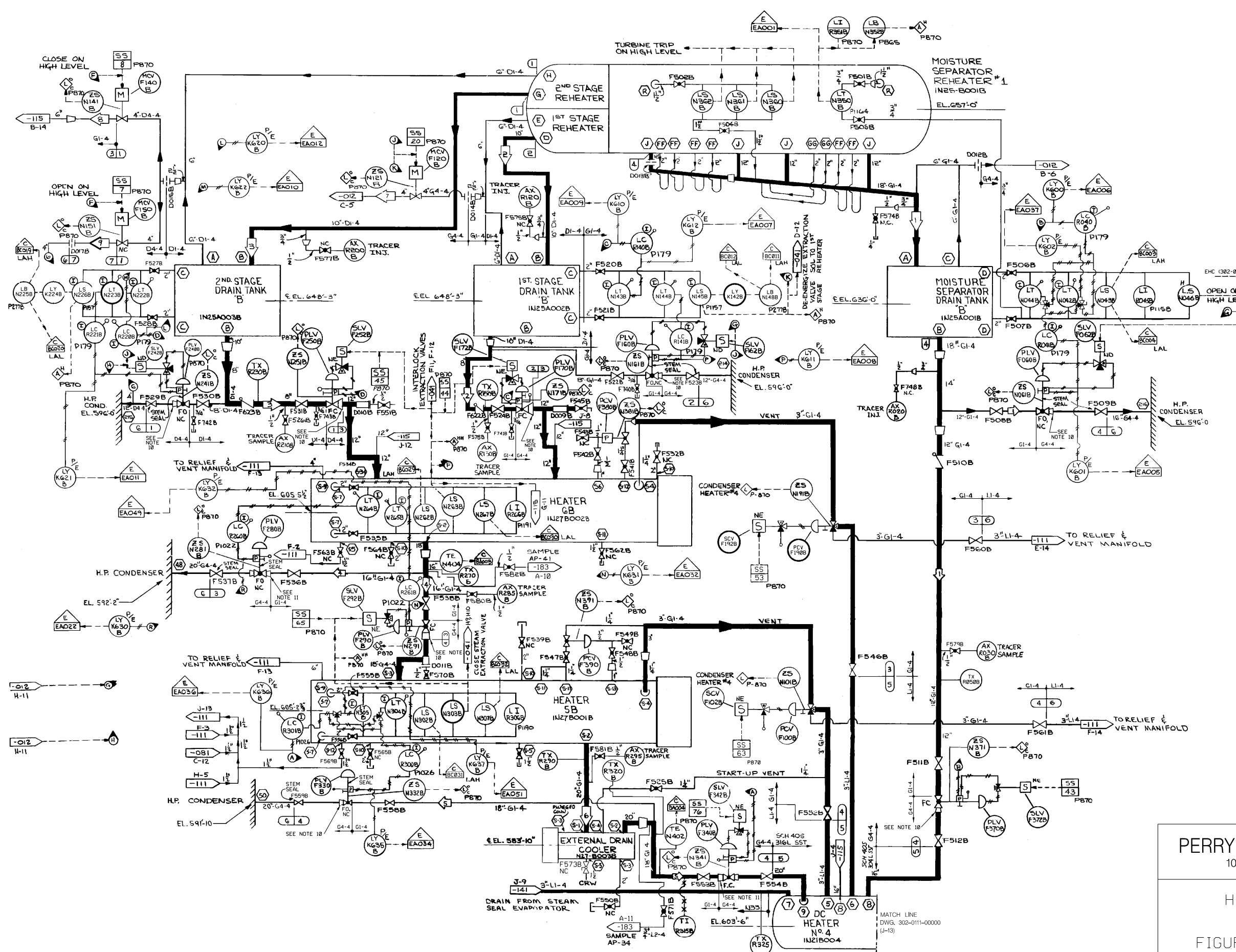

- (302-0111-00000, NOTE 6)
- (302-0111-00000, NOTE 7)
- NOTES:
- VENT ORIFICES ON HEATERS 5 AND 6 ARE INTERNAL.
  - FEEDWATER HEATERS SHOWN ON FOSTER-WHEELER DRAWINGS.
  - DC HEATER SHOWN ON CHICAGO HEATER DWG. D-3536.
  - MANUAL HEATER DRAINS ARE PIPED TO CONDENSER.
  - ALL PANEL AND RACKS ARE PREFIXED INH3, UNLESS OTHERWISE NOTED.
  - LOCAL PANELS AND RACKS P1164, P1157, P1158, P1180, P179 P1019, P1022, P2778 AND P1628 CARRY PREFIX INH1.
  - FOR STEM SEALING DETAILS, SEE DWG. 302-0151-00000.
  - PROCESS DATA SHOWN IN THE OPERATING DATA TABLE ON THIS SYSTEM DIAGRAM SHALL BE USED IN CONJUNCTION WITH THE DESIGN BASIS INFORMATION AND SHALL BE USED WITH CAUTION. IN GENERAL, THE OPERATING DATA (PRESSURES, TEMPERATURES, AND FLOWS) PROVIDED ON THIS DRAWING, REPRESENTS THE MOST COMMON OPERATING CONDITION, AND/OR SYSTEM MODE OF OPERATION AND/OR LINEUP, TO DETERMINE THE REQUIRED VALUES FOR A SPECIFIC OPERATING CONFIGURATION, THE APPROPRIATE DESIGN DOCUMENTS NEED TO BE REVIEWED.
  - OPERATING DATA IS TYPICALLY DERIVED FROM GE THERMAL KIT HEAT BALANCES. THE THERMAL KIT HEAT BALANCES ARE KEPT IN DESIGN INPUT RECORD (DIR) 237. OPERATING DATA SHOWN IS FOR RATED CONDITIONS APPLICABLE TO THE IMPLEMENTATION OF THE FOLLOWING PLANT CHANGES:
    - a.) POWER UPRATE TO 185% OF THE ORIGINAL DESIGN (REF.: TAF B1794).
    - b.) PARTIAL ARC ADMISSION (REF.: DCP 98-0058)
    - NOTE: PARTIAL ARC PARAMETER CHANGES (UP & DOWN) ARE SHOWN ONLY IF THEY ARE GREATER THAN 1% OF THE POWER UPRATE VALUES.
    - c.) LOW PRESSURE TURBINE ROTOR REPLACEMENT (REF.: ECP 04-0070).
  - REDUCER IS MADE OF ASTM A234 WP11 CHROME-MOLY MATERIAL WHICH IS COMPARABLE TO ASTM A234 WP22 REFERENCE ECP 13-0591-001.
  - INLET REDUCER IS MADE OF ASTM A234 WP11, BOTH OF WHICH ARE CHROME-MOLY MATERIAL COMPARABLE TO ASTM A234 WP22, REFERENCE ECP 13-0591-001.
- REFERENCES:
- 302-0012-00000 REHEAT STEAM SYSTEM N11
  - 302-0111-00000 HIGH PRESSURE HEATER DRAINS AND VENTS 'A' SYSTEM N25
  - 302-0115-00000 HIGH PRESSURE HEATER DRAINS AND VENTS 'B' SYSTEM N25
  - 302-0141-00000 STEAM SEAL SYSTEM N33
  - 302-0182-00000 TURBINE PLANT SAMPLING SYSTEM P33
  - 302-0183-00000 TURBINE PLANT SAMPLING SYSTEM P33
  - 302-0009-00000 REACTOR - TURBINE GENERATOR TRIP DIAGRAM
  - 302-0151-00000 CONDENSATE SEAL SYSTEM P12
  - 302-0081-00000 FEEDWATER SYSTEM N27
  - 302-0041-00000 EXTRACTION STEAM SYSTEM N36

(REV. 20 10/2017)

**PERRY NUCLEAR POWER PLANT**  
 10 CENTER RD., PERRY, OHIO 44081

**HIGH PRESSURE HEATER  
 DRAINS AND VENTS**  
 FIGURE 10.1-8 (SHEET 2 OF 4)  
 (DWG. D-302-0112-00000)

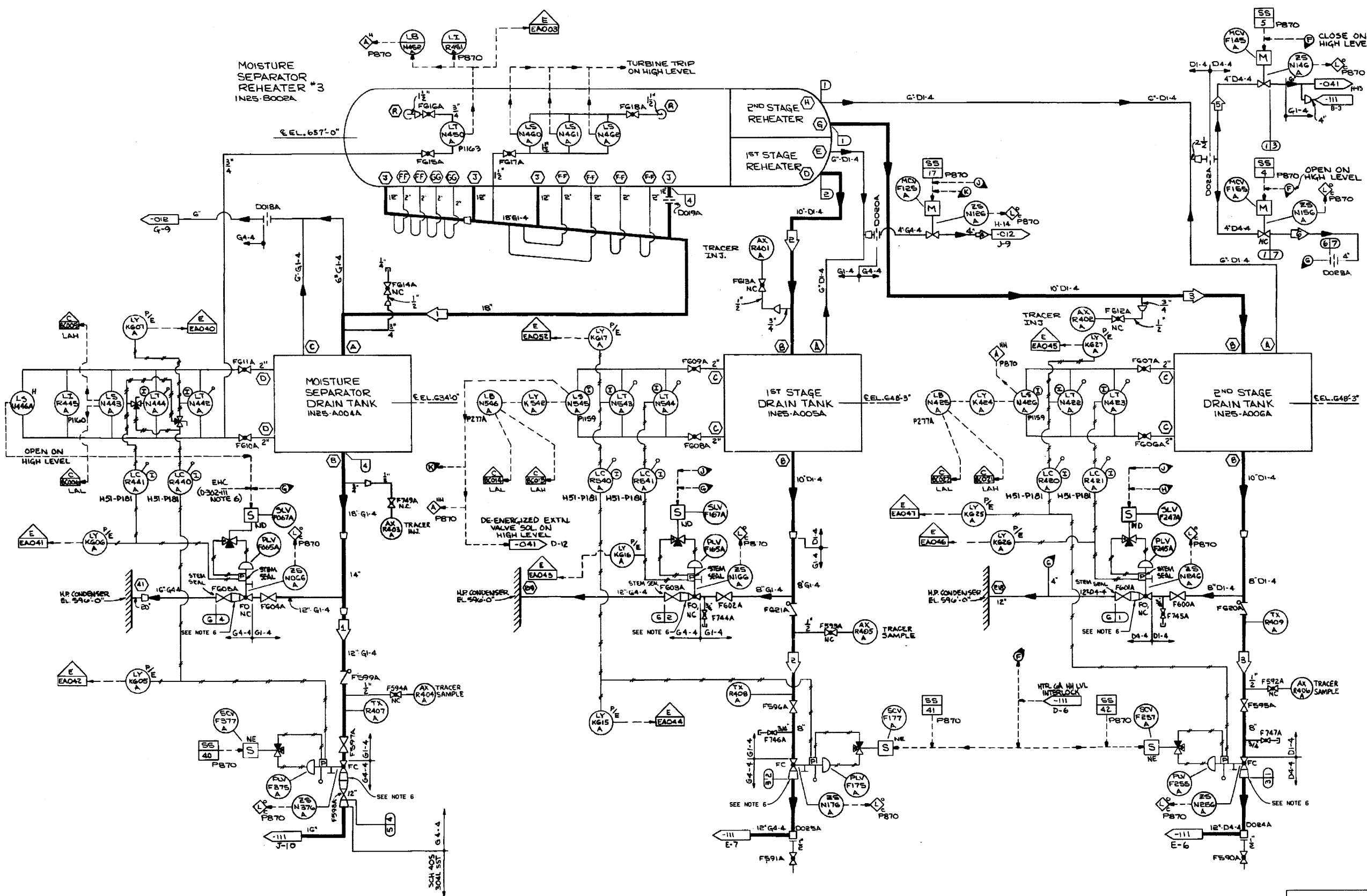

**OPERATING DATA (RATED)**  
SEE NOTES 4, 5

#	PSIA	LB/HR	°F	REMARKS
1	191.4	421,716	378	
2	352	178,858	477	
3	966	159,496	548	
4	552	17,885	477	
5	362	15,958	435	
6	529	15,453	474	

**DESIGN DATA**

D	NORMAL		UPSET		REMARKS
	PSIG	°F	PSIG	°F	
1	1258	575	NA	NA	
2	688	492	NA	NA	
3	488	458	NA	NA	
4	288	385	NA	NA	
5	128	358	NA	NA	
6	58	388	NA	NA	
7	358	588	NA	NA	

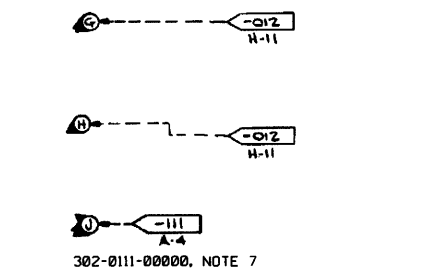

- NOTES:**
- ALL PANELS & RACKS ARE PREFIXED IHS3, UNLESS OTHERWISE NOTED.
  - LOCAL PANELS & RACKS P1159, P1168, P1163 & P277A, PREFIX IHS1.
  - FOR STEM SEALING DETAILS, SEE DWG. 302-0151-00000.
  - PROCESS DATA SHOWN IN THE OPERATING DATA TABLE ON THIS SYSTEM DIAGRAM SHALL BE USED IN CONJUNCTION WITH THE DESIGN BASIS INFORMATION AND SHALL BE USED WITH CAUTION. IN GENERAL, THE OPERATING DATA (PRESSURES, TEMPERATURES, AND FLOWS) PROVIDED ON THIS DRAWING, REPRESENTS THE MOST COMMON OPERATING CONDITION, AND/OR SYSTEM MODE OF OPERATION AND/OR LINEUP, TO DETERMINE THE REQUIRED VALUES FOR A SPECIFIC OPERATING CONFIGURATION, THE APPROPRIATE DESIGN DOCUMENTS NEED TO BE REVIEWED.
  - OPERATING DATA IS TYPICALLY DERIVED FROM GE THERMAL KIT HEAT BALANCES. THE THERMAL KIT HEAT BALANCES ARE KEPT IN DESIGN INPUT RECORD (DIR) 237. OPERATING DATA SHOWN IS FOR RATED CONDITIONS APPLICABLE TO THE IMPLEMENTATION OF THE FOLLOWING PLANT CHANGES:
    - POWER UPGRADE TO 105% OF THE ORIGINAL DESIGN (REF.: TAF 01794).
    - PARTIAL ARC ADMISSION (REF.: DCP 98-0050) NOTE: PARTIAL ARC PARAMETER CHANGES UP & DOWN ARE SHOWN ONLY IF THEY ARE GREATER THAN 1% OF THE POWER UPGRADE VALUES.
    - LOW PRESSURE TURBINE ROTOR REPLACEMENT (REF.: ECP 04-0078).
  - THE REDUCER IS MADE OF ASTM A234 WP11 CHROME-MOLY MATERIAL WHICH IS COMPARABLE TO A234 WP22 CL3. REFERENCE ECP 13-0248.

- REFERENCES:**
- 302-0012-00000 REHEAT STEAM SYSTEM IHS
  - 302-0041-00000 EXTRACTION STEAM SYSTEM N26
  - 302-0111-00000 HIGH PRESSURE HEATER DRAINS & VENTS 'A' SYSTEM N25
  - 002-0009-00000 REACTOR - TURBINE GENERATOR TRIP DIAGRAM
  - 302-0151-00000 CONDENSATE SEAL SYSTEM P12

(REV. 19 10/2015)

**PERRY NUCLEAR POWER PLANT**  
 10 CENTER RD., PERRY, OHIO 44081  
  
**HIGH PRESSURE HEATER DRAINS AND VENTS**  
**FIGURE 10.1-8 (SHEET 3 OF 4)**  
 (DWG. D-302-0114-00000)



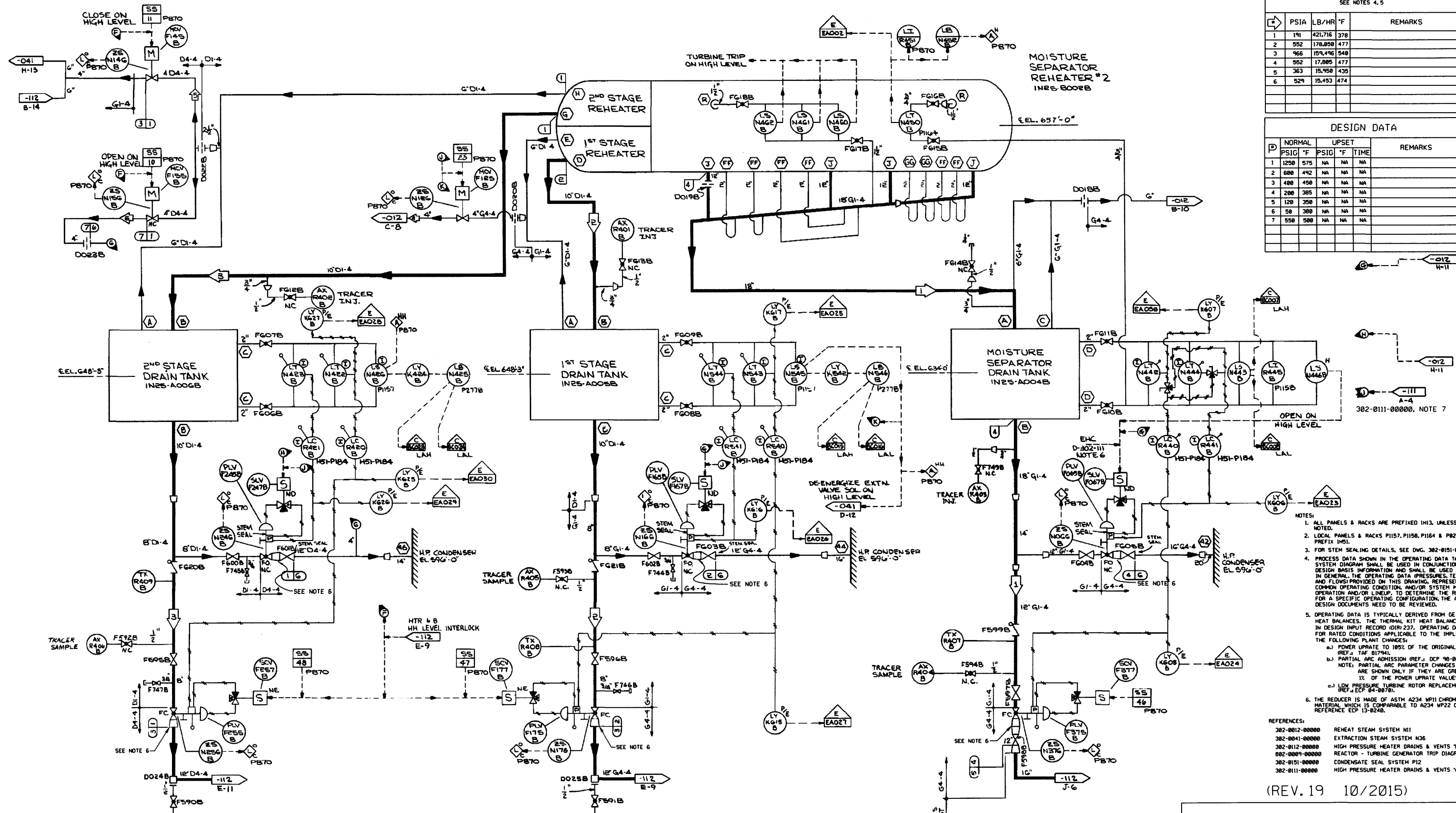

OPERATING DATA (RATED)  
SEE NOTES 4, 5

PSIA	LB/HR	°F	REMARKS
1	191	421,716	378
2	552	178,858	477
3	966	159,496	540
4	552	17,885	477
5	363	15,958	435
6	529	15,453	474

DESIGN DATA

D	NORMAL		UPSET		REMARKS
	PSIG	°F	PSIG	°F	
1	1250	575	NA	NA	NA
2	680	492	NA	NA	NA
3	480	456	NA	NA	NA
4	280	385	NA	NA	NA
5	128	358	NA	NA	NA
6	58	388	NA	NA	NA
7	558	588	NA	NA	NA

- NOTES:
- ALL PANELS & RACKS ARE PREFIXED I113, UNLESS OTHERWISE NOTED.
  - LOCAL PANELS & RACKS P1157, P1158, P1164 & P8227B, CARRY PREFIX I113.
  - FOR STEM SEALING DETAILS, SEE DWG. 382-0151-00000.
  - PROCESS DATA SHOWN IN THE OPERATING DATA TABLE ON THIS SYSTEM DIAGRAM SHALL BE USED IN CONJUNCTION WITH THE DESIGN BASIS INFORMATION AND SHALL BE USED WITH CAUTION. IN GENERAL, THE OPERATING DATA (PRESSURES, TEMPERATURES, AND FLOWS) PROVIDED ON THIS DRAWING, REPRESENTS THE MOST COMMON OPERATING CONDITION AND/OR SYSTEM MODE OF OPERATION AND/OR LINEUP, TO DETERMINE THE REQUIRED VALUES FOR A SPECIFIC OPERATING CONFIGURATION, THE APPROPRIATE DESIGN DOCUMENTS NEED TO BE REVIEWED.
  - OPERATING DATA IS TYPICALLY DERIVED FROM GE THERMAL KIT HEAT BALANCES. THE THERMAL KIT HEAT BALANCES ARE KEPT IN DESIGN INPUT RECORD (DIR) 237. OPERATING DATA SHOWN IS FOR RATED CONDITIONS APPLICABLE TO THE IMPLEMENTATION OF THE FOLLOWING PLANT CHANGES:
    - a) POWER UPGRADE TO 100% OF THE ORIGINAL DESIGN REF. JAF 81794.
    - b) PARTIAL ARC ADMISSION (REF. JDCP 90-8058) NOTE: PARTIAL ARC PARAMETER CHANGES (UP & DOWN) ARE SHOWN ONLY IF THEY ARE GREATER THAN 1% OF THE POWER UPGRADE VALUES.
    - c) LOW PRESSURE TURBINE ROTOR REPLACEMENT (REF. ECP 84-8878).
  - THE REDUCER IS MADE OF ASTM A234 WP11 CHROME-MOLY MATERIAL WHICH IS COMPARABLE TO A234 WP22 CL3. REFERENCE ECP 13-9240.

- REFERENCES:
- 382-0012-00000 REHEAT STEAM SYSTEM I11
  - 382-0041-00000 EXTRACTION STEAM SYSTEM I13
  - 382-0112-00000 HIGH PRESSURE HEATER DRAINS & VENTS 'B' SYSTEM I13
  - 882-0089-00000 REACTOR - TURBINE GENERATOR TRIP DIAGRAM
  - 382-0151-00000 CONDENSATE SEAL SYSTEM I12
  - 382-0111-00000 HIGH PRESSURE HEATER DRAINS & VENTS 'A' SYSTEM I13

(REV. 19 10/2015)

**PERRY NUCLEAR POWER PLANT**  
10 CENTER RD., PERRY, OHIO 44081

**HIGH PRESSURE HEATER  
DRAINS AND VENTS**  
FIGURE 10.1-8 (SHEET 4 OF 4)  
(DWG. D-302-0115-00000)

OPERATING DATA (RATED)  
SEE NOTES 9, 10

L#	PSIA	LB/HR	°F	REMARKS
1	61	394,912	229	
2	61	263,274	229	
3	61	131,637	229	
4	18.6	489,097	167	
5	5.0	724,188	115	
6	55	40,000	240	

DESIGN DATA

D	NORMAL PSIG	UPSET °F	PSIG	°F	TIME	REMARKS
1	75	310	-	-	-	
2	50	200	-	-	-	
3	50	150	-	-	-	
4	50	300	-	-	-	

- NOTES:
- ALL PIPING CLASSIFIED L1-4 EXCEPT PIPING DOWNSTREAM OF LEVEL CONTROL VALVES WHICH IS L4-4.
  - VENT DRIFTLINES ARE INTERNAL TO THE HEATERS WITH THE EXCEPTION OF THE NO.3 HEATERS.
  - HEATERS SHOWN ON FORSTER-WHEELER DRAWINGS WITH THE EXCEPTION OF THE NO.3 HEATERS WHICH ARE SHOWN ON SP4 DRAWINGS.
  - ALL MANUAL DRAINS ARE PIPED TO CONDENSER.
  - CONNECTION IN CONDENSER NECK.
  - ALL PANEL & RACKS ARE PREFIXED IH3, UNLESS OTHERWISE NOTED.
  - FOR STEM SEALING DETAILS, SEE DWG. 302-0151-00000.
  - VALVE DESIGNATION PER DRAWING 803-0148-00055.
  - PROCESS DATA SHOWN IN THE OPERATING DATA TABLE ON THIS SYSTEM DIAGRAM SHALL BE USED IN CONJUNCTION WITH THE DESIGN BASIS INFORMATION AND SHALL BE USED WITH CAUTION. IN GENERAL, THE OPERATING DATA (PRESSURES, TEMPERATURES, AND FLOWS) PROVIDED ON THIS DRAWING REPRESENTS THE MOST COMMON OPERATING CONDITION, AND/OR SYSTEM MODE OF OPERATION AND/OR LINEUP. TO DETERMINE THE REQUIRED VALUES FOR A SPECIFIC OPERATING CONFIGURATION, THE APPROPRIATE DESIGN DOCUMENTS NEED TO BE REVIEWED.
  - OPERATING DATA IS TYPICALLY DERIVED FROM GE THERMAL KIT HEAT BALANCES. THE THERMAL KIT HEAT BALANCES ARE KEPT IN DESIGN INPUT RECORD IDIR 237. OPERATING DATA SHOWN IS FOR RATED CONDITIONS APPLICABLE TO THE IMPLEMENTATION OF THE FOLLOWING PLANT CHANGES:
    - a) POWER UPRATE TO 185% OF ORIGINAL DESIGN (REF. IAF 81794).
    - b) PARTIAL ARC ADMISSION (REF. DCP 98-0020) NOTE: PARTIAL ARC PARAMETER CHANGES UP & DOWN ARE SHOWN ONLY IF THEY ARE GREATER THAN 1% OF THE POWER UPRATE VALUES.
    - c) LOW PRESSURE TURBINE ROTOR REPLACEMENT (REF. ECP 04-0070).

- REFERENCES:
- 302-0041-00000 EXTRACTION STEAM SYSTEM N36
  - 302-0111-00000 HIGH PRESSURE HEATER DRAINS & VENTS VENTS "A" SYSTEM N25
  - 302-0180-00000 TURBINE PLANT SAMPLING SYSTEM P33
  - 302-0181-00000 CONDENSATE SYSTEM N21
  - 302-0182-00000 CONDENSATE SEAL SYSTEM P12
  - 302-0082-00000 FEEDWATER SYSTEM N27

(REV. 21 10/2019)

**PERRY NUCLEAR POWER PLANT**  
10 CENTER RD., PERRY, OHIO 44081

LOW PRESSURE  
HEATER DRAINS AND VENTS  
FIGURE 10.1-9  
(DWG. D-302-0113-00000)

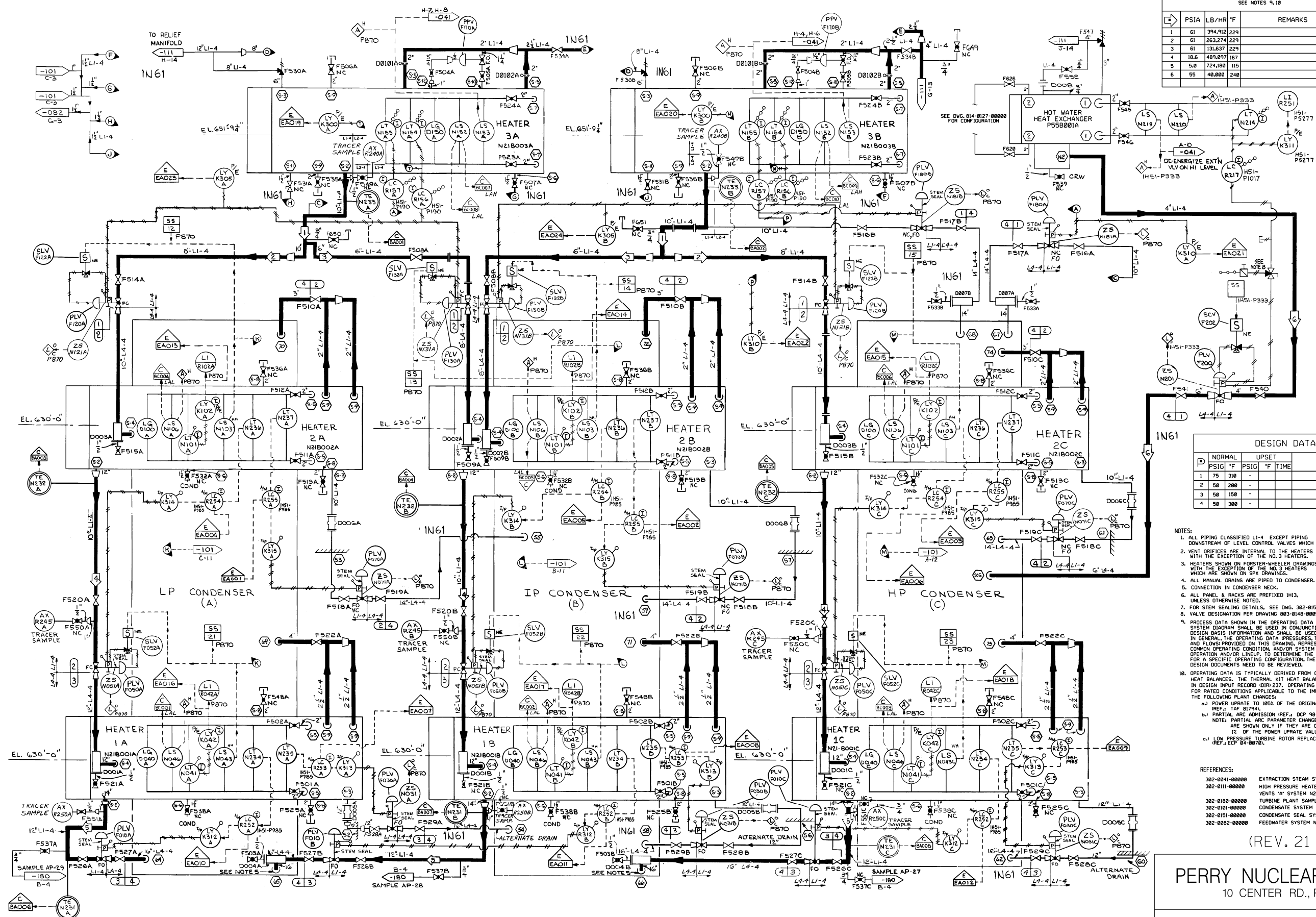

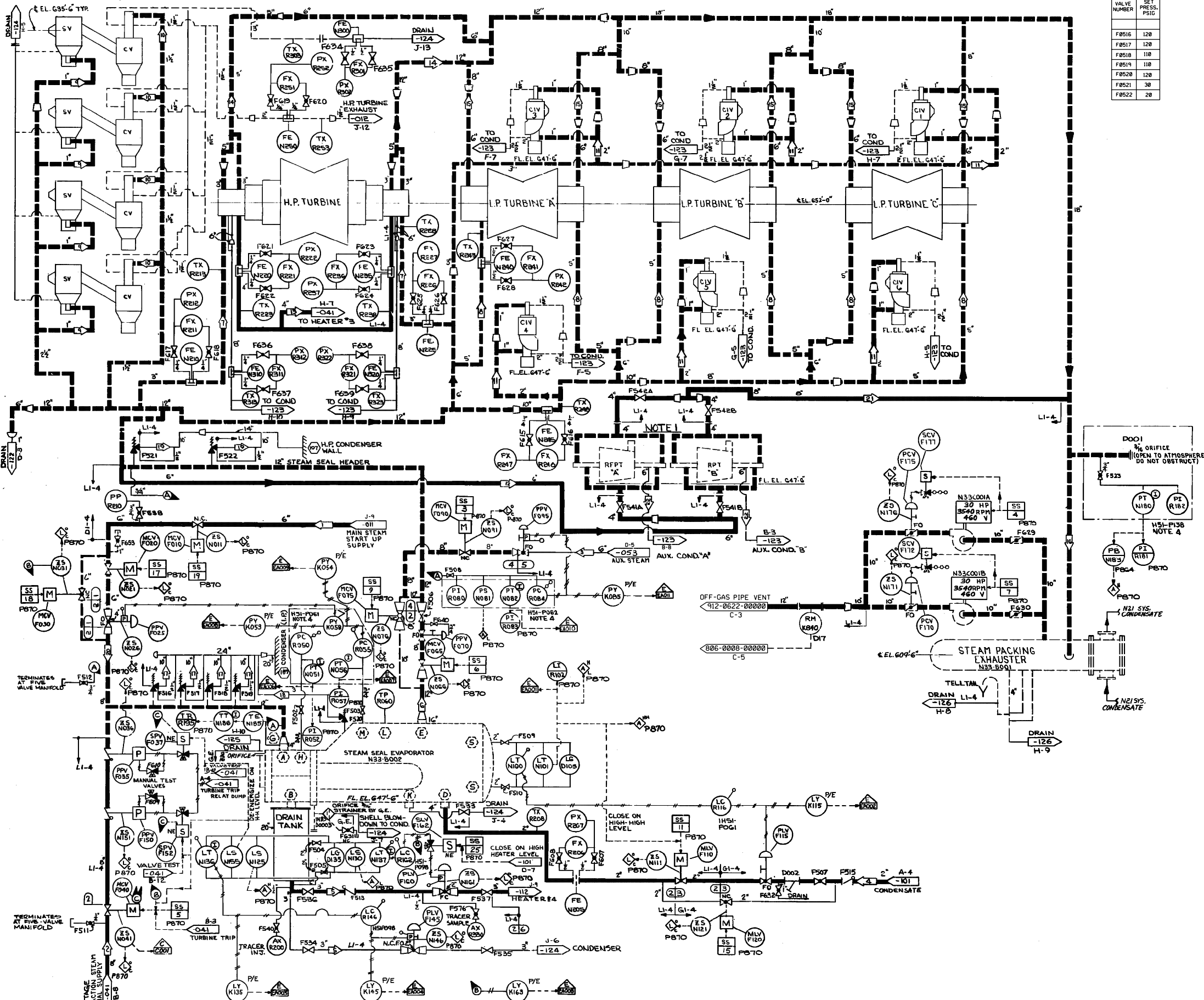

RELIEF VALVE SET PRESS. VALVE NUMBER	SET PRESS. PSIG
F8516	120
F8517	120
F8518	110
F8519	110
F8520	120
F8521	30
F8522	20

OPERATING DATA			
SEE NOTES 8, 9			
LINE NO.	PSIG	LB/HR	REMARKS
1	950	30,100	540 START UP
2	95	25,400	420 50,700 MAX.
3	90	25,000	331 45,000 MAX.
4	60-400	25,000	216 45,000 MAX.
5	67	130	313 START-UP (MAX.)
	33	65	278 START-UP (NORM.)
	82	110	326 FULL-LOAD (MAX.)
	83	60	327 FULL-LOAD (NORM.)
6	10-60	25,000	300 45,000 MAX.
7	4	1170	260
8	4	2940	260
9	4	290	260
10	4	50	260
11	4	75	260
12	4	810	260 MAX. 1620 LB/HR
13	180	8,150	380 39,380 MAX.
14	5" H <sub>2</sub> O VAC	550	200 PLUS 190 LB/HR AIR
15	5" H <sub>2</sub> O VAC	1110	200 PLUS 390 LB/HR AIR
16	10" H <sub>2</sub> O VAC	7760	200 PLUS 2720 LB/HR AIR
17	65	105,000	355 RELIEF VALVE
18	10	190,000	380 GPM RELIEF VALVE SP. GR. + 1
19	10	52,000	270 RELIEF VALVE
20	50	30,100	
21	5" H <sub>2</sub> O VAC	355	200 PLUS 130 LB/HR AIR MAX. 710 LB/HR STM. & 260 LB/HR AIR
22	5" H <sub>2</sub> O VAC	747	260 1490 LB/HR MAX.

DESIGN DATA					
LINE NO.	NORMAL		UPSET		REMARKS
	PSIG	F	PSIG	F TIME	
1	1250	575			
2	150	450			
3	600	320			
4	25	450			
5	195	385			
6	120	350			

- NOTES:
- OUTLINE OF RPT (PURCHASED CONNECTIONS) ON G.E. DWG. 5084-110C.
  - STEAM SEAL EVAPORATOR SHOWN ON G.E. DWG. 1160411.
  - STEAM PACKING EXHAUSTER SHOWN ON G.E. DWG. 11604761.
  - INSTRUMENT INCLUDED WITHIN BOUNDARY ARE LOCATED ON THE PANEL INDICATED.
  - ALL PANEL NUMBERS ARE PREFIXED BY 1H3-, UNLESS OTHERWISE NOTED.
  - FORWARD-REVERSE TUBE REPRESENTED BY SYMBOLS, ROOT VALVES BY G.E.T.
  - G.E.T. DOES NOT PROVIDE TEST THERMOWELLS IN THEIR PORTION OF THE STEAM SEAL PIPING. STRAIN COUPLES ARE TO BE SUPPLIED BY CEI FOR THE FOLLOWING TEMPERATURE TEST POINTS: R213, R228, R243, R248, R253, AND R303.
  - PROCESS DATA SHOWN IN THE OPERATING DATA TABLE ON THIS SYSTEM DIAGRAM SHALL BE USED IN CONJUNCTION WITH THE DESIGN BASIS INFORMATION AND SHALL BE USED WITH CAUTION. IN GENERAL, THE OPERATING DATA (PRESSURE, TEMPERATURES, AND FLOWS) PROVIDED ON THIS DRAWING, REPRESENTS THE MOST COMMON OPERATING CONDITION, AND/OR SYSTEM MODE OF OPERATION AND/OR LINEUP, TO DETERMINE THE REQUIRED VALUES FOR A SPECIFIC OPERATING CONFIGURATION, THE APPROPRIATE DESIGN DOCUMENTS NEED TO BE REVIEWED.
  - OPERATING DATA IS TYPICALLY DERIVED FROM GE THERMAL KIT HEAT BALANCES. THE THERMAL KIT HEAT BALANCES ARE KEPT IN DESIGN INPUT RECORD (DIR) 237. OPERATING DATA SHOWN IS FOR RATED CONDITIONS APPLICABLE TO THE IMPLEMENTATION OF THE FOLLOWING PLANT CHANGES:
    - a. POWER UPGRADE TO 105% OF THE ORIGINAL DESIGN (REF. TAF 81794).
    - b. PARTIAL ARC ADMISSION (REF. DCP 98-0050) NOTE: PARTIAL ARC PARAMETER CHANGES (UP & DOWN) ARE SHOWN ONLY IF THEY ARE GREATER THAN 1% OF THE POWER UPGRADE VALUES.
    - c. LOW PRESSURE TURBINE ROTOR REPLACEMENT (REF. ECP 84-0078).

- REFERENCES:
- 302-0011-00000 MAIN STEAM SYSTEM N11
  - 302-0041-00000 EXTRACTOR STEAM SYSTEM N36
  - 302-0101-00000 CONDENSATE SYSTEM N21
  - 302-0112-00000 HIGH PRESSURE HEATER DRAINS AND VENTS "B" SYSTEM N25
  - 302-0122-00000 MAIN, REHEAT, EXTRACTION AND MISCELLANEOUS DRAINS SYSTEM N22
  - 302-0123-00000 MAIN, REHEAT, EXTRACTION AND MISCELLANEOUS DRAINS SYSTEM N22
  - 302-0124-00000 MAIN, REHEAT, EXTRACTION AND MISCELLANEOUS DRAINS SYSTEM N22
  - 302-0125-00000 MAIN, REHEAT, EXTRACTION AND MISCELLANEOUS DRAINS SYSTEM N22
  - 912-0622-00000 OFF-GAS BUILDING EXHAUST SYSTEM N35
  - 806-0008-00000 PLANT RADIATION MONITORING SYSTEM D17
  - 12503148 ELEMENTARY DIAGRAM TRIP AND MONITORING SYSTEM (G.E.)
  - 834202 DIAGRAM OF STEAM SEAL SYSTEM (G.E.)
  - 302-0126-00000 MAIN, REHEAT, EXTRACTION AND MISCELLANEOUS DRAINS SYSTEM N22
  - 302-0053-00000 AUXILIARY STEAM SYSTEM P61
  - 302-0012-00000 REHEAT STEAM SYSTEM N11

(Rev. 18 10/13)

**PERRY NUCLEAR POWER PLANT**  
10 CENTER RD., PERRY, OHIO 44081

STEAM SEAL SYSTEM

FIGURE 10.1-10  
(DWG. D-302-0141-00000)

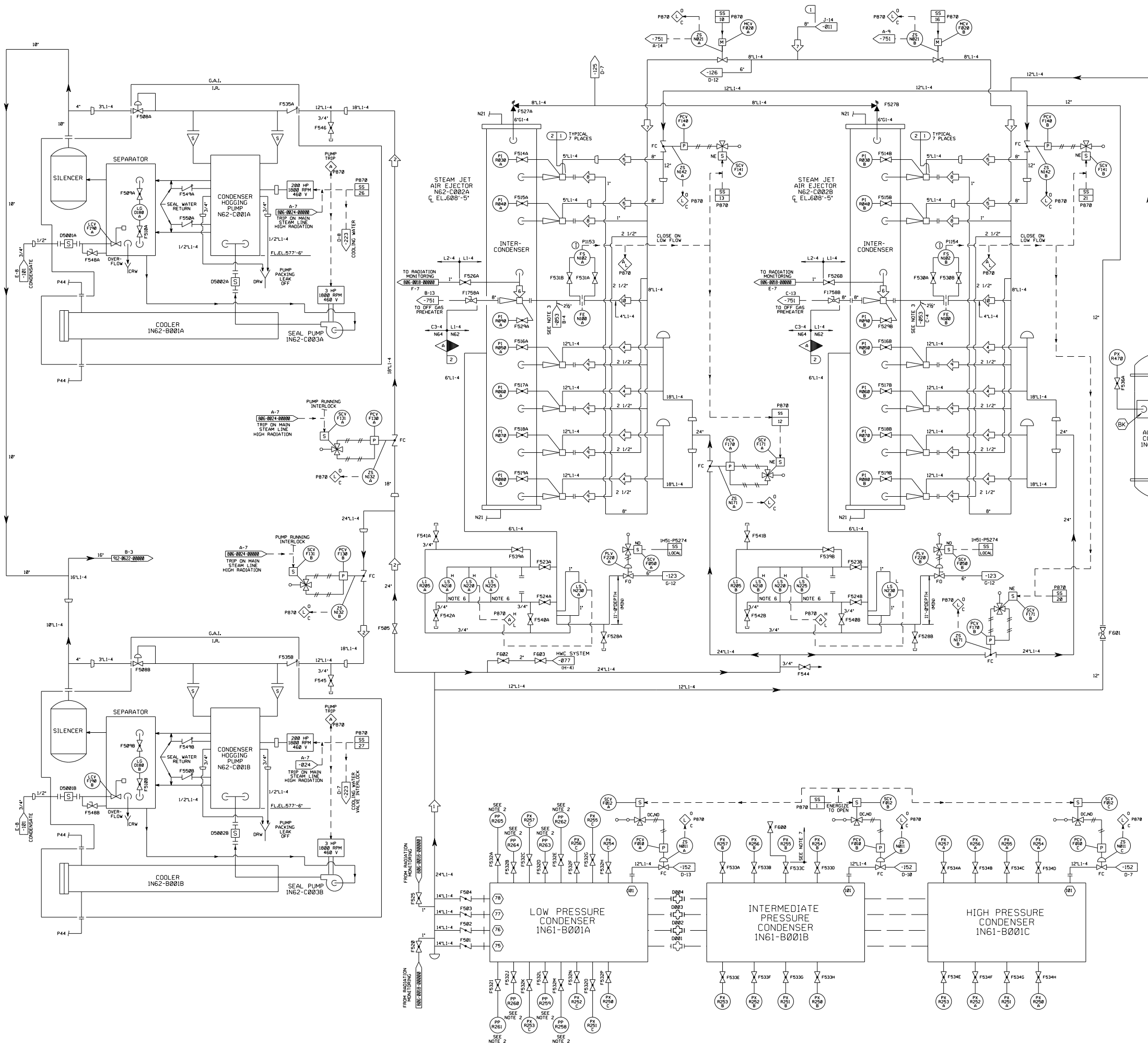

OPERATING DATA  
SEE NOTES 8, 9

#	IN/HA	°F	#/HR	REMARKS
1	2	100	3100	AIR AND VAPOR
2	3.0	75	2500	ACFM
3	2	100	260	AIR AND VAPOR
4	2	100	775	AIR AND VAPOR
5	2	100	130	AIR AND VAPOR
6	8	228	654	AIR AND VAPOR
7	140	353	24,377	STEAM
8	140	353	408	STEAM
9	140	353	3509	STEAM
10	140	353	4925	STEAM

DESIGN DATA

#	NORMAL	UPSET	REMARKS
1	PSIG °F	PSIG °F	TIME
2	150 353	150 353	

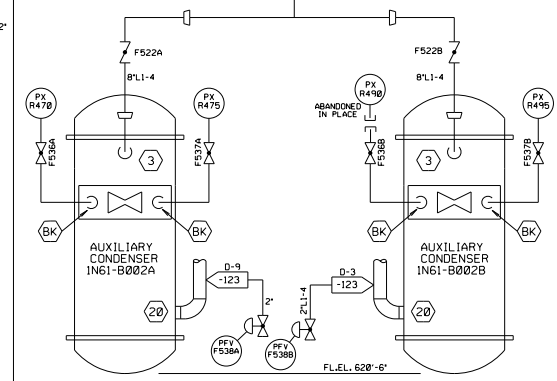

- REFERENCES:
- 302-001-00000 MAIN STEAM SYSTEM, N11
  - 302-0053-00000 AUXILIARY STEAM, P61
  - 302-0101-00000 CONDENSATE SYSTEM, N21
  - 302-0123-00000 M.R.E. AND MISCELLANEOUS DRAINS SYSTEM, N22
  - 302-0125-00000 M.R.E. AND MISCELLANEOUS DRAINS SYSTEM, N22
  - 302-0126-00000 M.R.E. AND MISCELLANEOUS DRAINS SYSTEM, N22
  - 302-0152-00000 CONDENSATE SEAL SYSTEM, P12
  - 302-0222-00000 TURBINE BLDG. CLOSED COOLING SYSTEM, P44
  - 302-0751-00000 OFF-GAS LOW TEMPERATURE SYSTEM, N64
  - 806-0018-00000 OFF-GAS PRETREATMENT RADIATION MONITORS AND SAMPLERS K-612.
  - 806-0024-00000 PLANT RADIATION MONITORING SYSTEM
  - 912-0622-00000 OFF-GAS BUILDING EXHAUST AND WATER TREATMENT BUILDING VENTILATION SYSTEMS, M36 & M37
  - 881E555 PERFORMANCE TEST PIPING, HOODS A AND B
  - 883E481 PERFORMANCE TEST PIPING, HOOD C

- NOTES:
- ALL PANELS AND RACKS CARRY PREFIX IH3, UNLESS OTHERWISE NOTED.
  - BASKET TIPS SUPPLIED BY G.E.T. NOT TO BE CONNECTED FOR ASME TEST.
  - TEST CONNECTION PERMANENTLY PIPED.
  - NO IMPACT TESTS ARE REQUIRED FOR PIPING (C3-4) BETWEEN SJAE AND RECOMBINERS.
  - THE SYMBOL  $\nabla$  DESIGNATES THOSE NON-SAFETY AREAS OF THE SYSTEM WHERE THE AUGMENTED QUALITY ASSURANCE PROGRAM REQUIREMENTS DEFINED IN SP-45 APPLY.
  - LEVEL SWITCHES N210A & B AND N225A & B ARE ABANDONED IN PLACE.
  - TUBING UPSTREAM OF IN62F0533C IS LINEAR LOW DENSITY POLYETHYLENE. IN62F0600 IS A NON-CALIBRATED VALVED FLOW METER. PRESSURE TEST POINT LOCATION PX-R0200B IS BEING UTILIZED AS THE TRACER GAS "TEST SHOT" INJECTION POINT FOR CONDENSER IN-LEAKAGE TESTING ACTIVITIES.
  - PROCESS DATA SHALL BE USED IN CONJUNCTION WITH THE DESIGN BASIS INFORMATION AND SHALL BE USED WITH CAUTION. IN GENERAL, THE OPERATING DATA (PRESSURES, TEMPERATURES, AND FLOWS) PROVIDED ON THIS DRAWING, REPRESENTS THE MOST COMMON OPERATING CONDITION, AND/OR SYSTEM MODE OF OPERATION AND/OR LINEUP TO DETERMINE THE REQUIRED VALUES FOR A SPECIFIC OPERATING CONFIGURATION, THE APPROPRIATE DESIGN DOCUMENTS NEED TO BE REVIEWED.
  - OPERATING DATA IS TYPICALLY DERIVED FROM GE THERMAL KIT HEAT BALANCES. THE THERMAL KIT HEAT BALANCES ARE KEPT IN DESIGN INPUT RECORD (DIR) 237. OPERATING DATA SHOWN IS FOR RATED CONDITIONS APPLICABLE TO THE IMPLEMENTATION OF THE FOLLOWING PLANT CHANGES:
    - a. POWER UPGRADE TO 105% OF THE ORIGINAL DESIGN (REF: TAF 81794).
    - b. PARTIAL ARC ADMISSION (REF: DCP 98-0050) NOTE: PARTIAL ARC PARAMETER CHANGES UP & DOWN ARE SHOWN ONLY IF THEY ARE GREATER THAN 1% OF THE POWER UPGRADE VALUES.
    - c. LOW PRESSURE TURBINE ROTOR REPLACEMENT (REF: ECP 04-0070).

(REV. 20 10/2017)

PERRY NUCLEAR POWER PLANT  
10 CENTER RD., PERRY, OHIO 44081

CONDENSER AIR  
REMOVAL SYSTEM  
FIGURE 10.1-11  
(DWG. D-302-0131-00000)

©General Electric Company. This document and information is GE Confidential & Proprietary Information. No part of this document and information may be reproduced, transmitted, stored in a retrieval system nor translated into any human or computer language, in any form or by any means, electronic, mechanical, magnetic, optical, chemical, manual, or otherwise, without the prior written permission of the General Electric Company.

THE VALUE OF GENERATOR OUTPUT SHOWN ON THIS HEAT BALANCE IS AFTER ALL POWER FOR EXCITATION AND OTHER TURBINE-GENERATOR AUXILIARIES HAS BEEN DEDUCTED

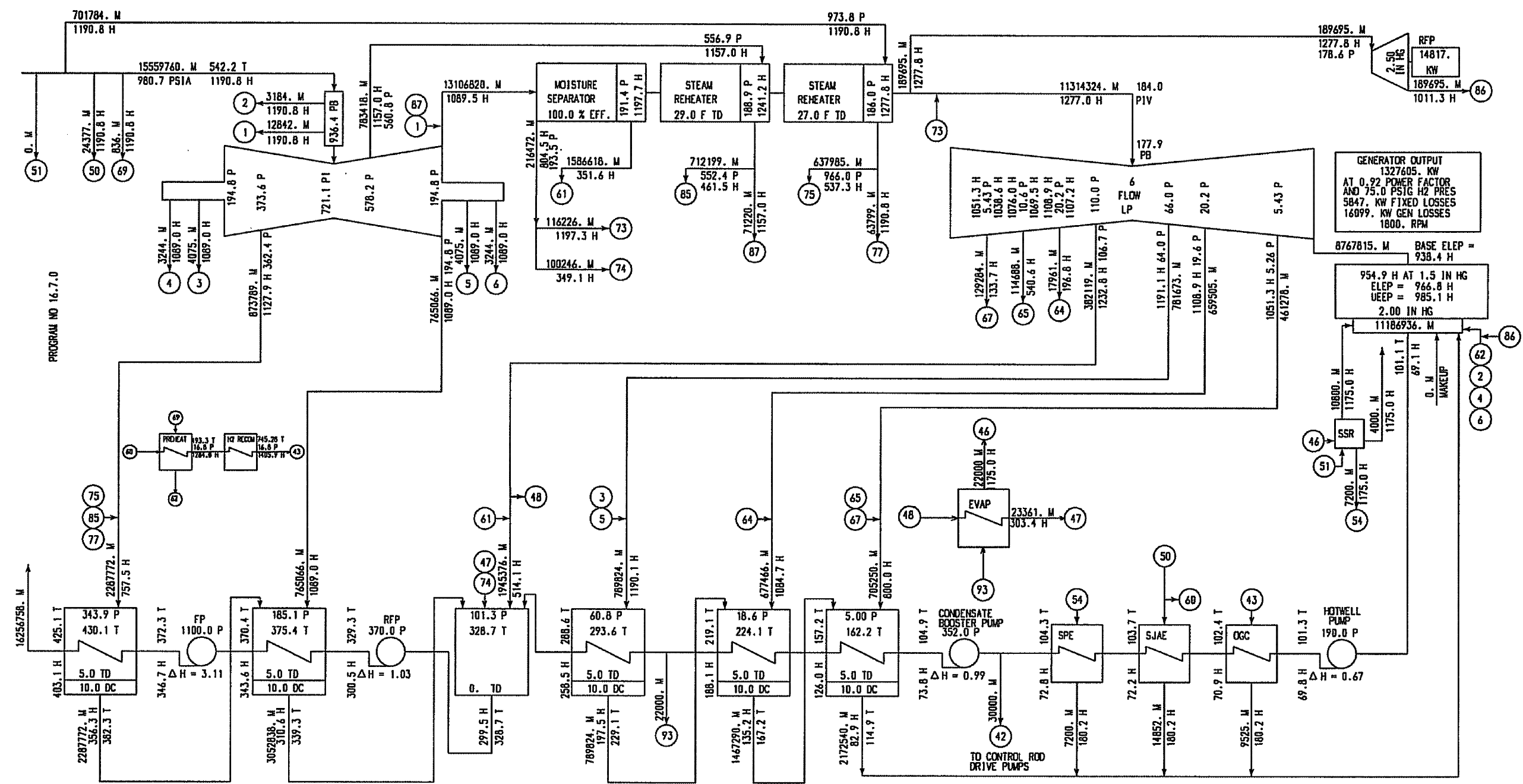

VALVE BEST POINT =  $\frac{15554973 \cdot (1190.8 - 403.1) + 701784 \cdot (1190.8 - 403.1) + 30000 \cdot (1190.8 - 72.8)}{1327605} = 9670$  BTU / KW-HR

FENOC - Perry Unit 1  
Turbine No. 170X655  
LP Monoblock Upgrade  
New 43" LSB Design  
Rated Thermal Power  
(NSSS = 3762.5 MWth)

LEGEND - CALCULATIONS BASED ON 1967 ASME STEAM TABLES  
M - FLOW-LB/HR  
P - PRESSURE-PSIA  
H - ENTHALPY-BTU/LB  
T - TEMPERATURE-F DEGREES

1327605 KW 2.00 IN HG ABS 0. PCT MU  
TC6F 43.0 IN LSB 1800 RPM  
980.7 PSIA 1190.8 BTU / LB TWO STAGE REHEAT  
GEN- 1446700. KVA 0.90 PF L10 75.0 PSIG H2 PRES

**PERRY NUCLEAR POWER PLANT**  
10 CENTER RD., PERRY, OHIO 44081

---

RATED POWER

---

FIGURE 10.1-12



©General Electric Company. This document and information is GE Confidential & Proprietary information. No part of this document and information may be reproduced, transmitted, stored in a retrieval system nor translated into any human or computer language, in any form or by any means, electronic, mechanical, magnetic, optical, chemical, manual, or otherwise, without the prior written permission of the General Electric Company.

TURBINE AND EXTRACTION ARRANGEMENT IS SCHEMATIC ONLY

CALCULATED DATA - NOT GUARANTEED

THE VALUE OF GENERATOR OUTPUT SHOWN ON THIS HEAT BALANCE IS AFTER ALL POWER FOR EXCITATION AND OTHER TURBINE-GENERATOR AUXILIARIES HAS BEEN DEDUCTED

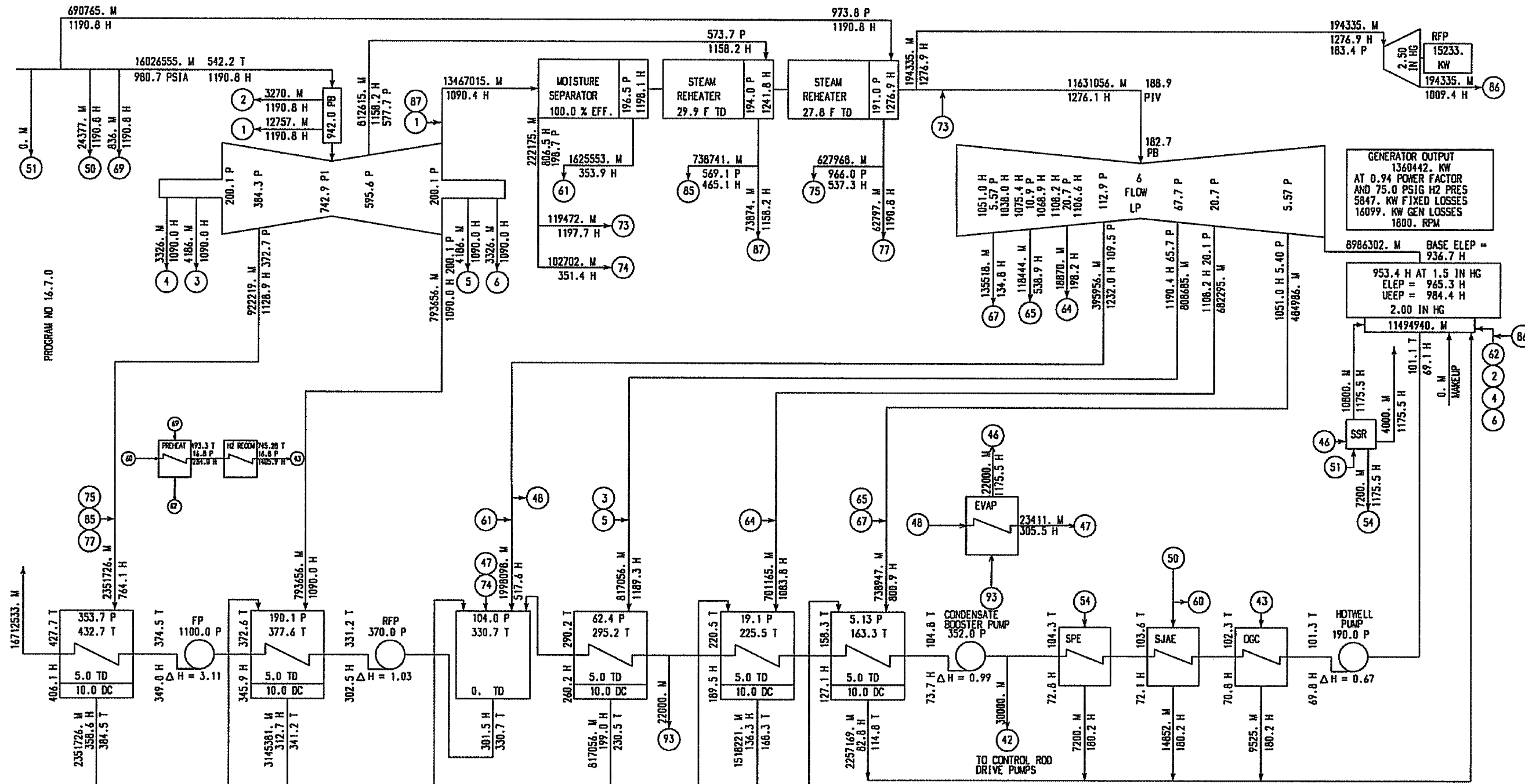

PROGRAM NO 16.7-0

$$\text{NET HEAT RATE} = \frac{16021768 \cdot (1190.8 - 406.1) + 690765 \cdot (1190.8 - 406.1) + 30000 \cdot (1190.8 - 72.8)}{1360442} = 9665 \frac{\text{BTU}}{\text{KW-HR}}$$

FENOC - Perry Unit 1  
 Turbine No. 170X655  
 LP Monoblock Upgrade  
 New 43" LSB Design  
 VWO Flow Condition  
 (3% Flow Margin Assumption)

LEGEND - CALCULATIONS BASED ON 1967 ASME STEAM TABLES  
 M - FLOW-LB/HR  
 P - PRESSURE-PSIA  
 H - ENTHALPY-BTU/LB  
 T - TEMPERATURE-F DEGREES  
 1327405 KW 2.00 IN HG ABS  
 TC4F 43.0 IN LSB 1800 RPM  
 980.7 PSIA 1190.8 BTU / LB  
 GEN- 1446700 KVA 0.90 PF L10  
 0. PCT MU  
 TWO STAGE REHEAT  
 75.0 PSIG H2 PRES

(Rev. 18 10/13)

**PERRY NUCLEAR POWER PLANT**  
 10 CENTER RD., PERRY, OHIO 44081

---

DESIGNED POWER - VWO

---

FIGURE 10.1-13

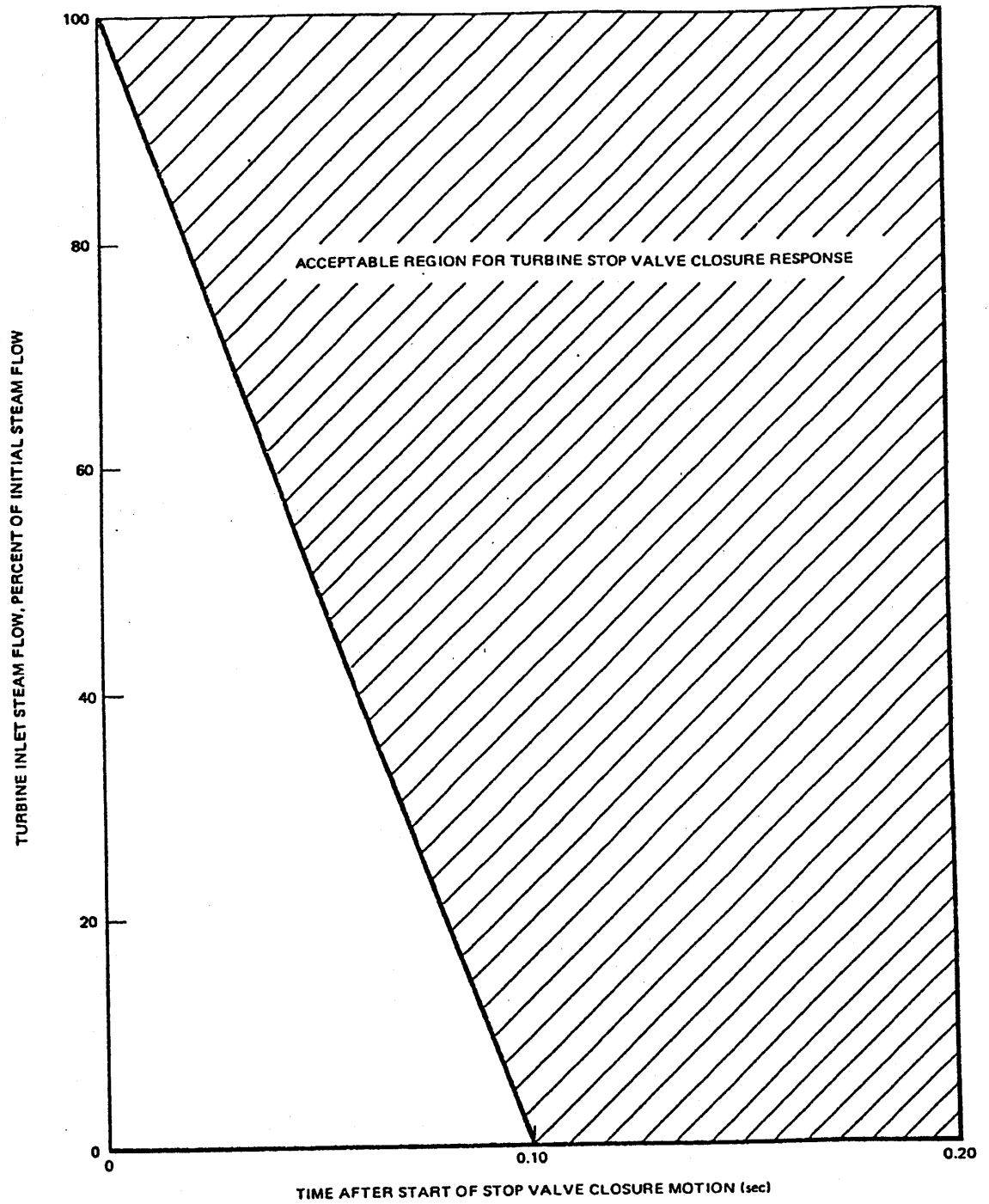

(Rev. 12 1/03)



**PERRY NUCLEAR POWER PLANT**

Turbine Stop Valve  
Closure Characteristics

Figure 10.2-1

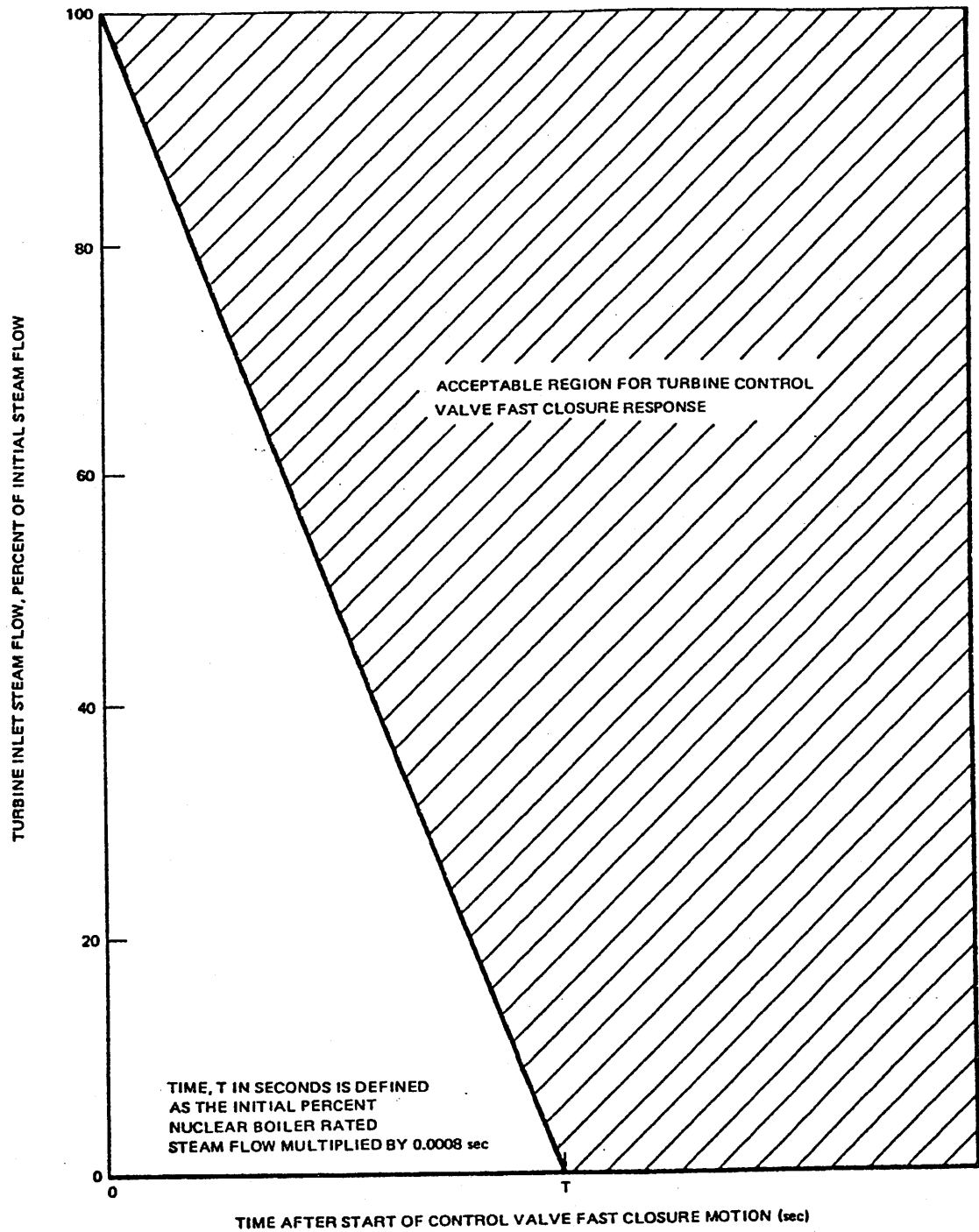

(Rev. 12 1/03)



**PERRY NUCLEAR POWER PLANT**

Turbine Control Valve Fast Closure Characteristics

Figure 10.2-2

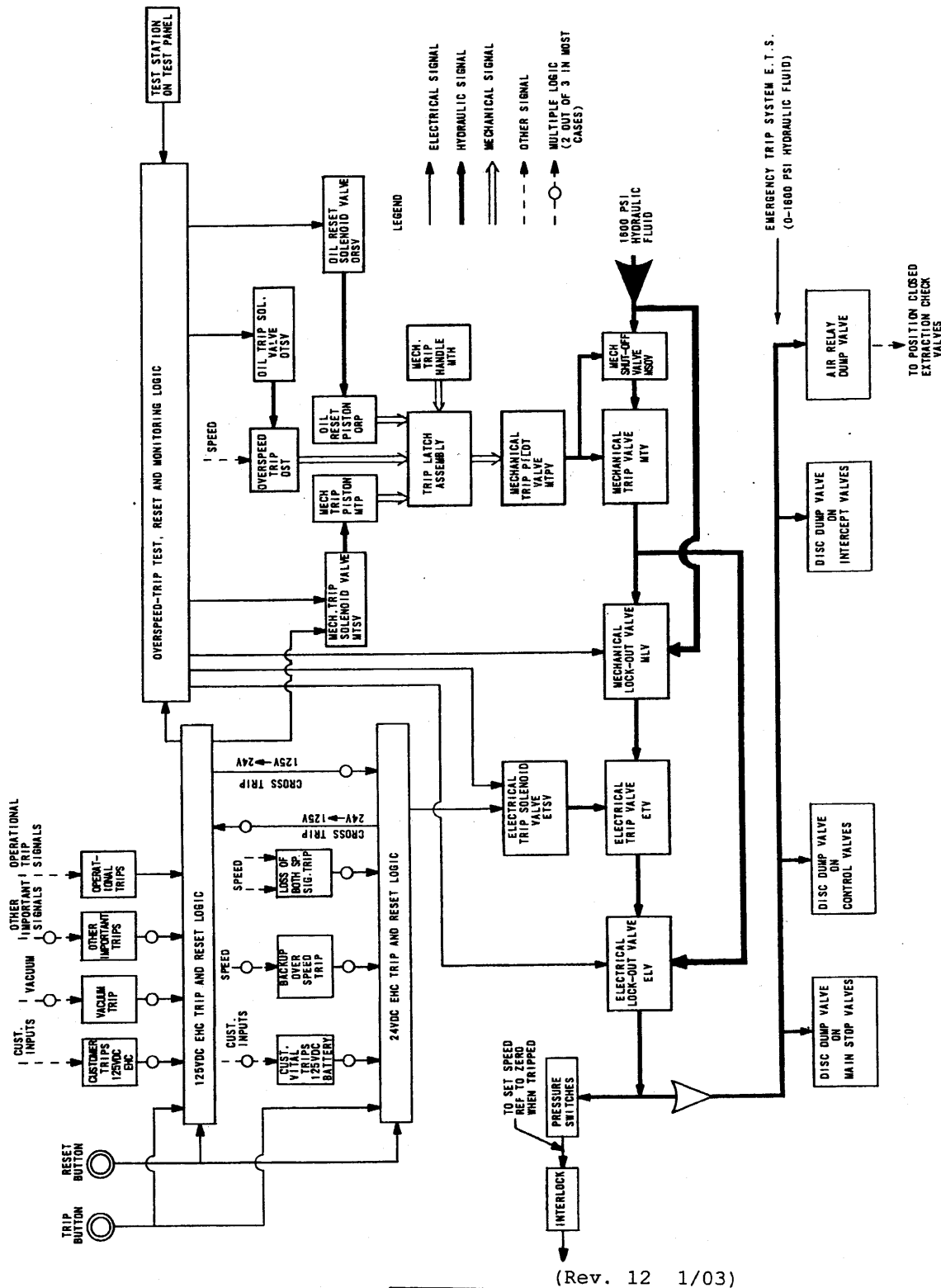

(Rev. 12 1/03)

## PERRY NUCLEAR POWER PLANT

Turbine Protection System  
Block Diagram

Figure 10.2-3

RELIEF VALVE SET PRESSURE	
VALVE N°	PS.I.G.
RUPTURE DISC	3675
F503A AND F503B	2450
F512A & F512B	120
F516	120

OPERATING DATA				
SEE NOTE 6				
PSIG	SCFM	F	BY	REMARKS
1	2200	75	75	NOTE 1
2	90	75	75	NOTE 1

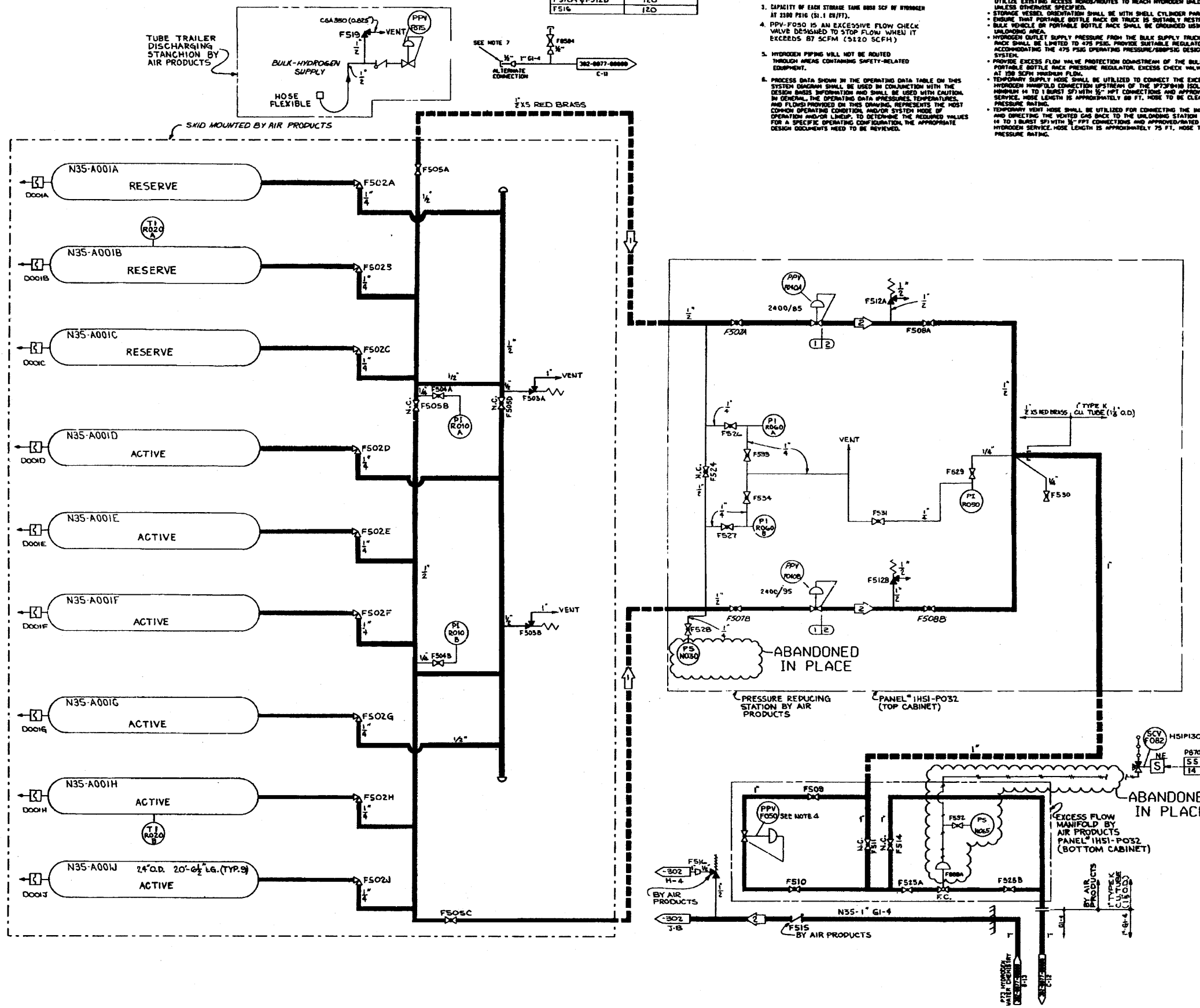

- NOTES:
- MAXIMUM FLOW DURING GENERATOR FILLING OPERATION IS 175 SCFH. THE FLOW DURING NORMAL OPERATION IS 800 SCFH PER DAY MAXIMUM (8.42 SCFH).
  - ALL PANELS CARRY PREFIX 1HS1- UNLESS OTHERWISE NOTED.
  - CAPACITY OF EACH STORAGE TANK 8000 SCFH OF HYDROGEN AT 2300 PSIG (3.1 IN/FT).
  - PPV-F503 IS AN EXCESS FLOW CHECK VALVE DESIGNED TO STOP FLOW WHEN IT EXCEEDS 87 SCFH (3120 SCFH).
  - HYDROGEN PIPING WILL NOT BE ROUTED THROUGH AREAS CONTAINING SAFETY-RELATED EQUIPMENT.
  - PROCESS DATA SHOWN IN THE OPERATING DATA TABLE ON THIS SYSTEM DIAGRAM SHALL BE USED IN CONJUNCTION WITH THE DESIGN BASIS INFORMATION AND SHALL BE USED WITH CAUTION. IN GENERAL, THE OPERATING DATA (PRESSURES, TEMPERATURES, AND FLOWS) PROVIDED ON THIS DRAWING REPRESENTS THE MOST COMMON OPERATING CONDITION AND/OR SYSTEM MODE OF OPERATION AND/OR LINEUP. TO DETERMINE THE REQUIRED VALUES FOR A SPECIFIC OPERATING CONFIGURATION, THE APPROPRIATE DESIGN DOCUMENTS SHOULD BE REVIEWED.
  - ALTERNATE HYDROGEN CONNECTION BY OTHERS REQUIREMENTS ARE AS FOLLOWS:
    - STORAGE VESSEL SHALL BE LIMITED TO 62.24 SCFH.
    - STORAGE PRESSURE SHALL BE LIMITED TO 2300 PSIG.
    - HYDROGEN VESSEL CAPACITY SHALL BE LIMITED TO 7,267 SCFH.
    - STORAGE LOCATION SHALL BE PLACED FROM AREA IMMEDIATELY EAST OF EXISTING UNLOADING STATION APPROXIMATELY 80 FT. NORTH OF TEMPORARY TIE-IN CONNECTION POINT AT HEATER BAY SURROUNDING STRUCTURE. CURRENT HYDROGEN SEPARATION DISTANCES SHALL BE MAINTAINED.
    - UTILIZE EXISTING ACCESS ROADS/ROUTES TO REACH HYDROGEN UNLOADING AREA, UNLESS OTHERWISE SPECIFIED.
    - STORAGE VESSEL ORIENTATION SHALL BE WITH SHIELD CYLINDER PARALLEL WITH N. TURBINE BLDG. WALL.
    - ENSURE THAT PORTABLE BOTTLE RACK OR TRUCK IS SUSTAINABLY RESTRAINED TO OPPOSE DAMAGING WINDS.
    - BULK VEHICLE OR PORTABLE BOTTLE RACK SHALL BE GROUNDED USING EXISTING GROUNDING CLAMP IN UNLOADING AREA.
    - HYDROGEN OUTLET SUPPLY PRESSURE FROM THE BULK SUPPLY TRUCK OR FROM THE PORTABLE BOTTLE RACK SHALL BE LIMITED TO 475 PSIG. PROVIDE SUSTAINABLE REGULATOR AND RELIEF CAPABILITY FOR ACCOMMODATING THE 475 PSIG OPERATING PRESSURE/DESIGN PRESSURE OF THE DOWNSTREAM SYSTEM.
    - PROVIDE EXCESS FLOW VALVE PROTECTION DOWNSTREAM OF THE BULK SUPPLY TRUCK OR PORTABLE BOTTLE RACK PRESSURE REGULATOR. EXCESS CHECK VALVE SHALL BE RATED FOR CLOSURE AT 150 SCFH HYDROGEN FLOW.
    - TEMPORARY SUPPLY HOSE SHALL BE UTILIZED TO CONNECT THE EXCESS FLOW VALVE OUTLET TO THE P77 HYDROGEN MANIFOLD CONNECTION UPSTREAM OF THE P77/F503 ISOLATION VALVE. HOSE SHALL BE 3000 PSIG MINIMUM 1/2 IN. BURST STRENGTH 1/2 IN. CONNECTIONS AND APPROVED FOR HYDROGEN SERVICE. HOSE LENGTH IS APPROXIMATELY 80 FT. HOSE TO BE CLEARLY MARKED FOR PRESSURE RATING.
    - TEMPORARY VENT HOSE SHALL BE UTILIZED FOR CONNECTING THE 1HS1/PO32 OUTLET CONNECTION AND DIRECTING THE VENTED GAS BACK TO THE UNLOADING STATION AREA. HOSE SHALL BE 800 PSIG MINIMUM 1/2 IN. BURST STRENGTH 1/2 IN. CONNECTIONS AND APPROVED FOR HYDROGEN SERVICE. HOSE LENGTH IS APPROXIMATELY 75 FT. HOSE TO BE CLEARLY MARKED FOR PRESSURE RATING.

DESIGN DATA						
P	NORMAL PSIG	UPSET PSIG	F TIME	BY	REMARK	R
1	2500	200		JW		
2	125	200		JW		

- REFERENCES: (AIR PRODUCTS)
- 100 SX 24410 SCHEMATIC FLOW DIAGRAM - BULK GAS SUPPLY SYSTEM
  - 100 SX 10074-1000 PRESSURE REDUCING STATION AND EXCESS FLOW BARriers CABINETS AND SUPPORT ASSEMBLY
  - 100 SX 20240-0000 NINE VESSEL BULK GAS PRODUCT STORAGE MODULAR ASSEMBLY MODEL 1
  - 300-0302-00000 GENERATOR H<sub>2</sub> AND CO<sub>2</sub> GAS CONTROL SYSTEM HDS
  - 100 SX 00010 HYDROGEN STORAGE AND SUPPLY SYSTEM
  - 12521300 GAS CONTROL PIPING DIAGRAM, I.E. DRAWING

(Rev. 15 10/07)

**PERRY NUCLEAR POWER PLANT**

Hydrogen Supply System

Figure 10.2-4

(Dwg. D-302-301)

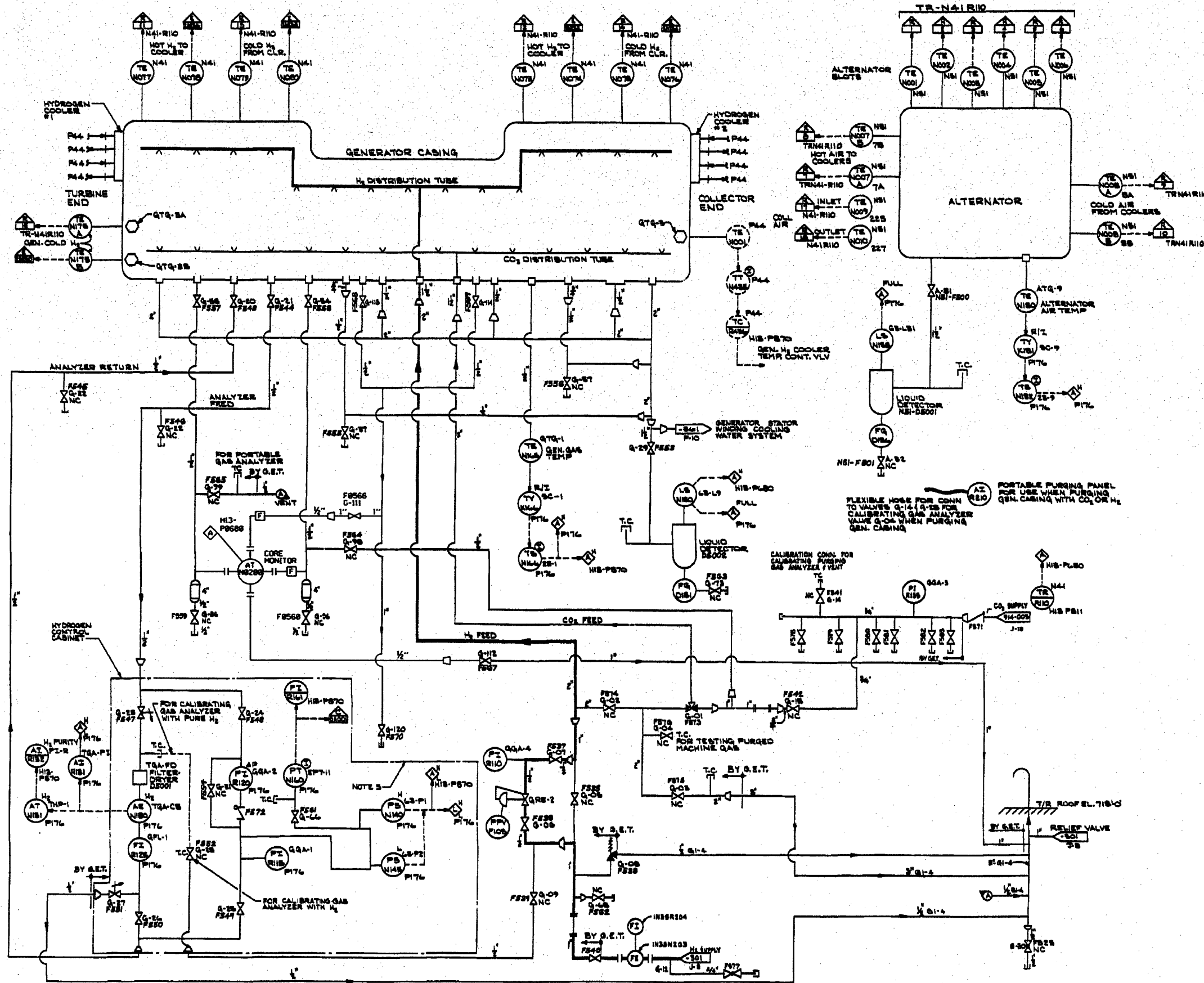

- NOTES:
1. THIS DRAWING IS A SCHEMATIC DIAGRAM OF THE VENDOR SUPPLIED GAS CONTROL SYSTEM. IT IS INTENDED TO SHOW MAJOR EQUIPMENT, SYSTEM INTERFACES AND INSTRUMENTATION AND CONTROL IMPLEMENTATION IN SUFFICIENT DETAIL TO PERMIT UNDERSTANDING THE SYSTEM OPERATION.
  2. A SYSTEM TROUBLE ALARM FOR THE HSI-P176 PANEL IS TRANSMITTED TO HSI-P584.
  3. ALL PANELS CARRY PREFIX HSI, UNLESS NOTED OTHERWISE. DEVICES WITHIN BOUNDARY ARE LOCATED IN THE GAS TIGHT COMPARTMENT OF THE HYDROGEN AND STATOR COOLING WATER CABINET, HSI-P176.
  4. VALVES SHOWN IN NORMAL POSITION FOR AUTOMATIC OPERATION IN HYDROGEN.
  5. ALL INSTRUMENTS CARRY PREFIX HSI, UNLESS NOTED OTHERWISE. G.E.T. INSTRUMENT DESIGNATIONS ARE SHOWN ADJACENT THE HSI TAG NUMBERS FOR CORRELATION WITH G.E.T. SUPPLIED DOCUMENTATION.
  6. HYDROGEN PIPING WILL NOT BE ROUTED THROUGH AREAS CONTAINING SAFETY RELATED EQUIPMENT.

- REFERENCES:
- D-302-222 TURBINE BUILDING CLOSED COOLING SYSTEM P44
  - D-302-201 HYDROGEN SUPPLY SYSTEM H25
  - D-34-805 CARBON DIOXIDE SYSTEM P54
  - 4549-43-016 GENERATOR ELECTRICAL OUTLINE, G.E.T. DWG. 7746204
  - 4549-43-052 GAS CONTROL PIPING DIAGRAM, G.E.T. DWG. 12501309
  - 4549-43-074 CABINET OUTLINE HYDROGEN AND STATOR COOLING G.E.T. DWG. 12501307
  - 4549-43-176 ALTERNATOR CONNECTIONS, G.E.T. DWG. 34018848
  - 4549-43-177 ALTERNATOR MECHANICAL OUTLINE, G.E.T. DWG. 34018898
  - 4549-65-027 SCHEMATIC DIAGRAM HYDROGEN AND STATOR COOLING G.E.T. DWG. 15003572
  - 4549-65-048 GENERATOR PIPING CONNECTIONS, G.E.T. DWG. 13307482
  - 4549-43-050 CO2 MANIFOLD OUTLINE, G.E.T. DWG. 10053647
  - 4549-43-054 FLOAT TRAP OUTLINE, G.E.T. DWG. 14204548
  - D-302-201 GENERATOR STATOR WINDING COOLING WATER SYSTEM H43
  - 4549-65-075 GAS CONTROL PIPING DIAG. G.E.T. DWG. 2834504

(Rev. 16 10/09)

**PERRY NUCLEAR POWER PLANT**

Generator H<sub>2</sub> and CO<sub>2</sub> Gas Control System

Figure 10.2-5  
(Dwg. D-302-302)



OPERATING DATA

PSIG	GPM	"F	BY	REMARKS	REV
300	0"	0"			

DESIGN DATA

NORMAL	UPSET	BY	CHKD	REV			
PSIG	"F	PSIG	"F	TIME			
1	300	0"	300	0"			
2	300	0"	500	0"			
3							
4							

DESIGN CONDITIONS ARE INDICATED IN THE UPSET DESIGN DATA COLUMN.

- NOTES:
- THE CONTROL UNIT FOR EACH HAZARD AREA SELECTOR CONTROL VALVE INCLUDES:
    - A TIMER TO LIMIT THE DISCHARGE PERIOD
    - SUPERVISORY RELAYS TO MONITOR POWER SUPPLY TO THE UNIT AND INTERCONNECTING CIRCUITRY AND OPERATIONAL RELAYS TO INITIATE OPERATION OF THE ELECTRO-MANUAL PILOT VALVES, MASTER VALVES, AND INITIATE A FIRE ALARM SIGNAL. DETAILS ARE SHOWN ON VENDOR DWG.
  - THE CONTROL UNITS FOR THE MASTER CONTROL VALVES HAVE NECESSARY RELAYS TO USE SELECTOR VALVE CONTROL UNIT SIGNALS TO OPERATE THE SELECTOR VALVES. DETAILS SHOWN ON VENDOR DWG.
  - ALL ALARMS PRINT OUT AT THE SECONDARY ALARM STATION.
  - PRIMARY METHOD OF SYSTEM INITIATION SHALL BE BY THE LOCAL MANUAL PULL STATIONS IN UNIT 1 & 2.
  - APPLICABLE TO CO<sub>2</sub> SYSTEMS ASSOCIATED WITH PANELS 1 AND 2 HS1P191, 1 AND 2 HS1P200, 1 AND 2 HS1P201, 1 AND 2 HS1P213 AND 1 AND 2 HS1P214 ONLY.
  - SWITCH PROVIDES OVERRIDE TO INADVERTENT CO<sub>2</sub> HVAC FAN TRIP SIGNAL FOR SYSTEMS 1 AND 2 HS1P191, 1 AND 2 HS1P200, AND 1 AND 2 HS1P201 ONLY.
  - INDIVIDUAL BREAKGLASS STATIONS (1) ELECTRO-MANUAL PILOT CABINET/ROOM ARE PROVIDED FOR MANUAL INITIATION OF THE CO<sub>2</sub> SYSTEM FOR EACH DIESEL GENERATOR ROOM.
  - DELETED
  - THE SYMBOL  DESIGNATES THOSE NON-SAFETY PORTIONS OF THE SYSTEM WHERE THE AUGMENTED QUALITY ASSURANCE PROGRAM APPLIES.
  - ABANDONED IN PLACE PER TECHNICAL ASSIGNMENT FILE B1653.
  - DETAIL 1 AND INSTRUMENT/VALVE CROSS REFERENCE TABLE SEE DWG. 914-0005-00000.
  - MASTER SELECTION VALVE 2P54F3521 AND PANEL 2HS1P0216 HAVE BEEN ABANDONED IN PLACE PER ECP 12-0017.

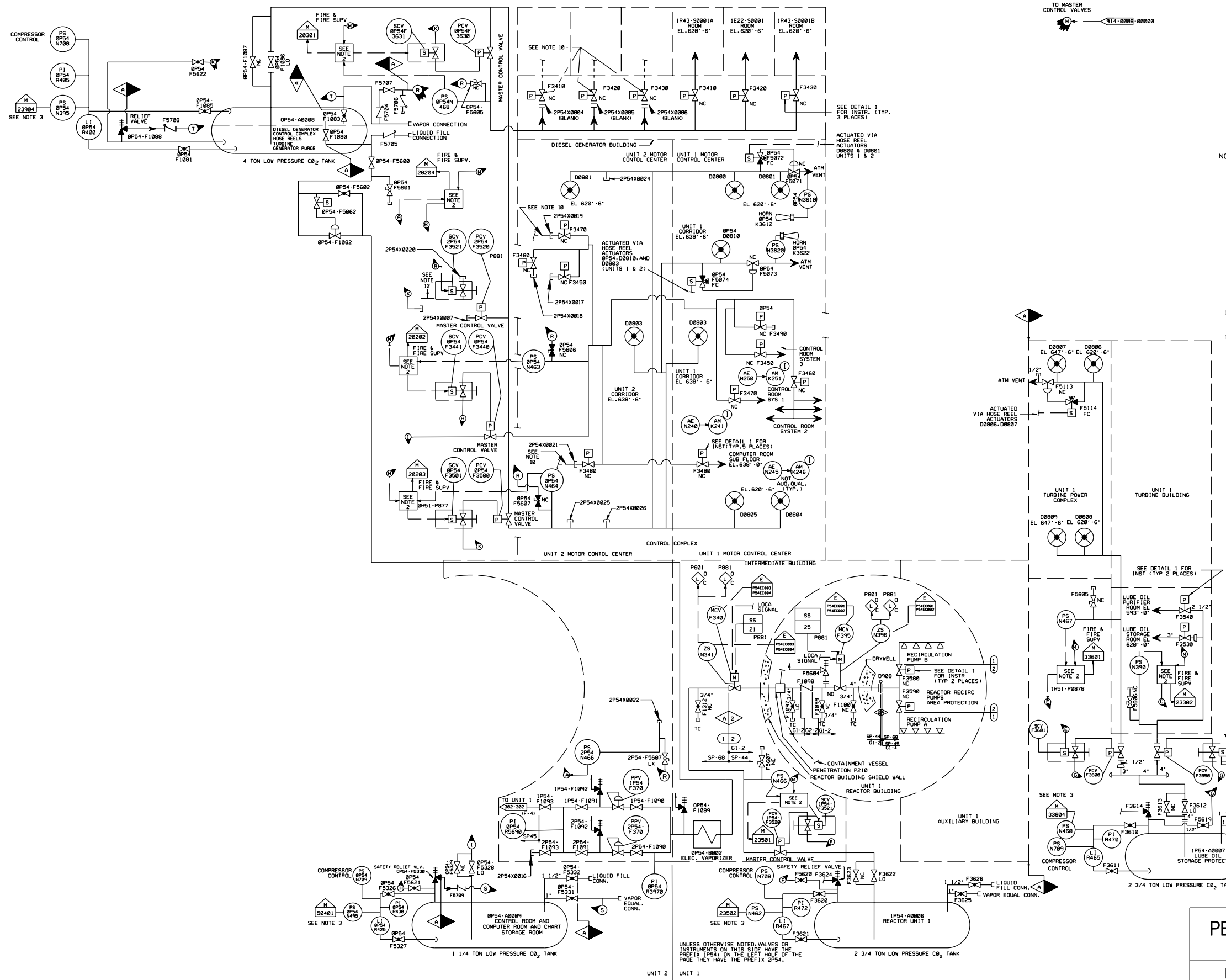

(Rev. 18 10/13)

**PERRY NUCLEAR POWER PLANT**  
 10 CENTER RD., PERRY, OHIO 44081  
**FIRE SERVICE CARBON DIOXIDE**

Figure 10.2-6

(DWG. D-914-0005-00000)

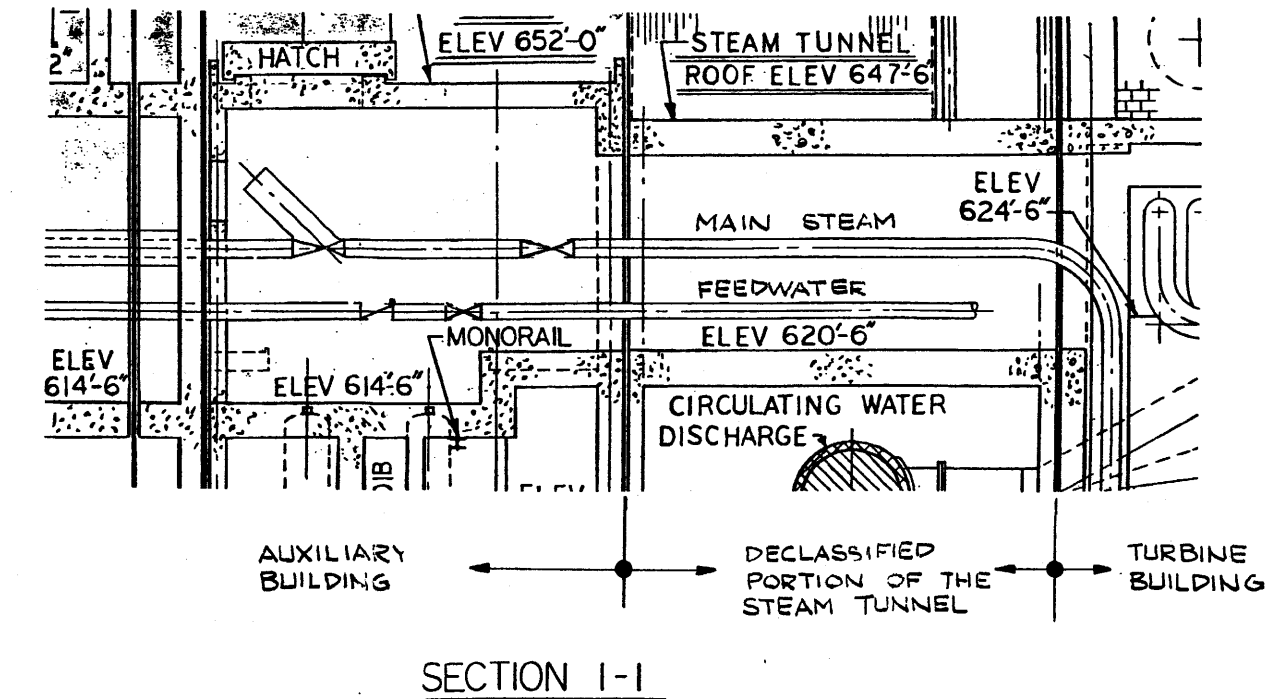
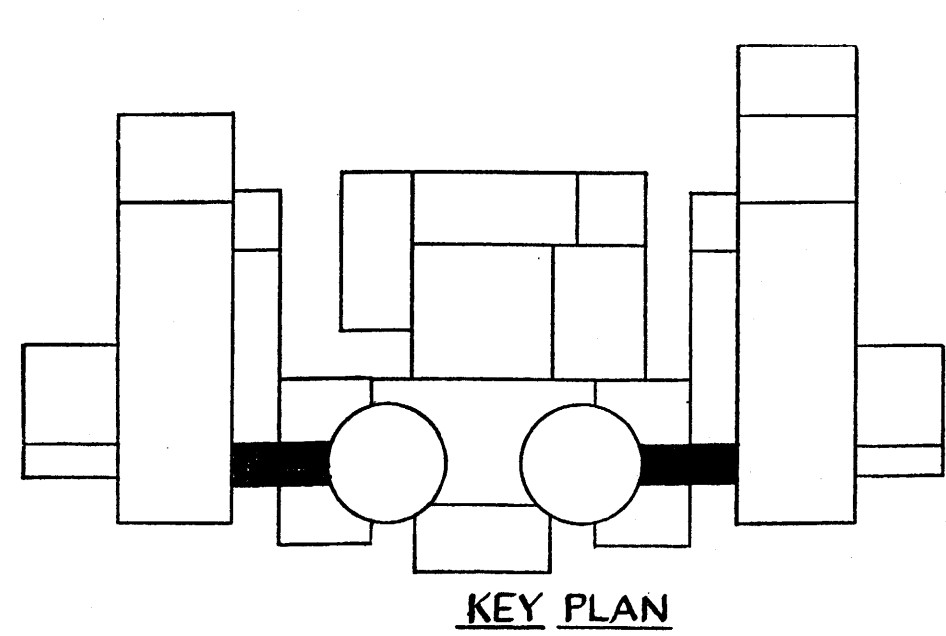
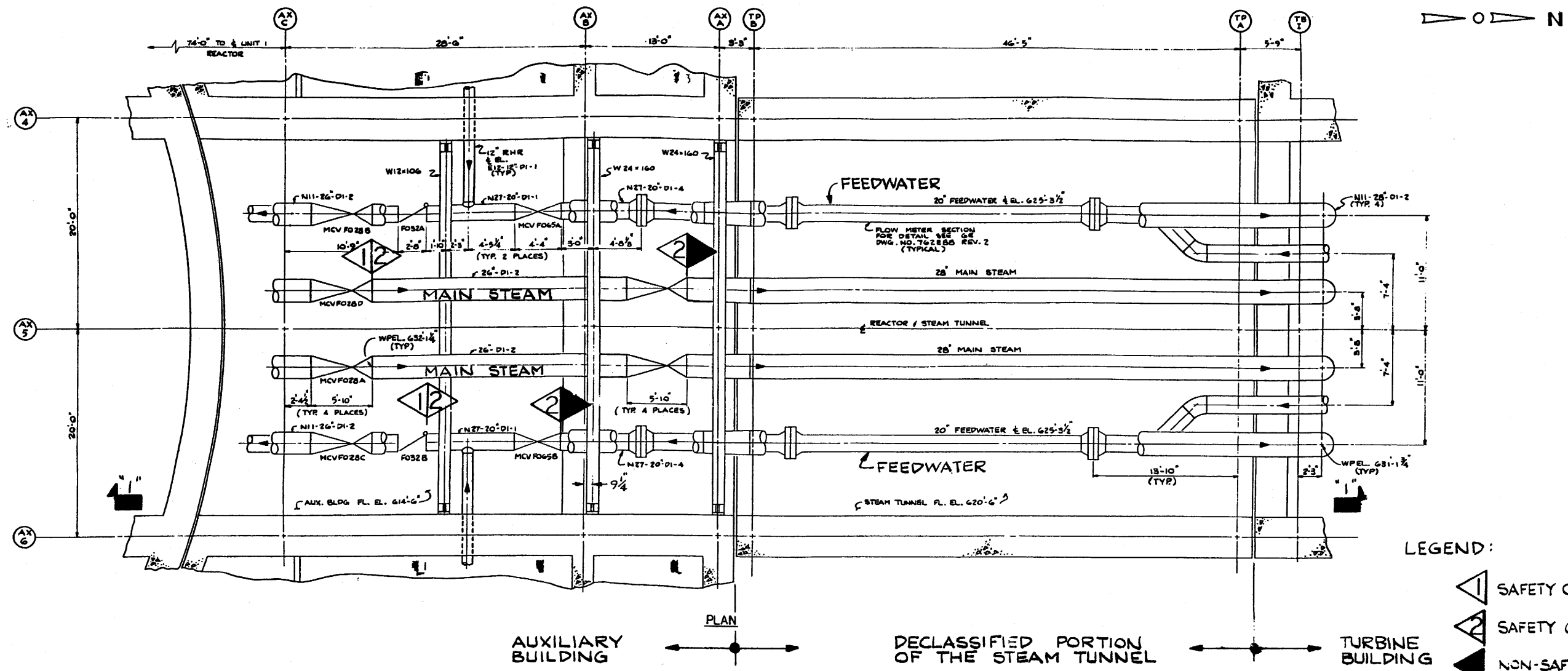

NOTE:

1. ALL BEAM SIZES, RESTRAINT LOCATIONS AND DIMENSIONS ARE APPROXIMATE.

2. RESTRAINTS ALLOW AXIAL GROWTH, BUT LIMIT AXIAL ROTATION.

(Rev. 12 1/03)

**PERRY NUCLEAR POWER PLANT**

Steam Tunnel Arrangement

Figure 10.3-1

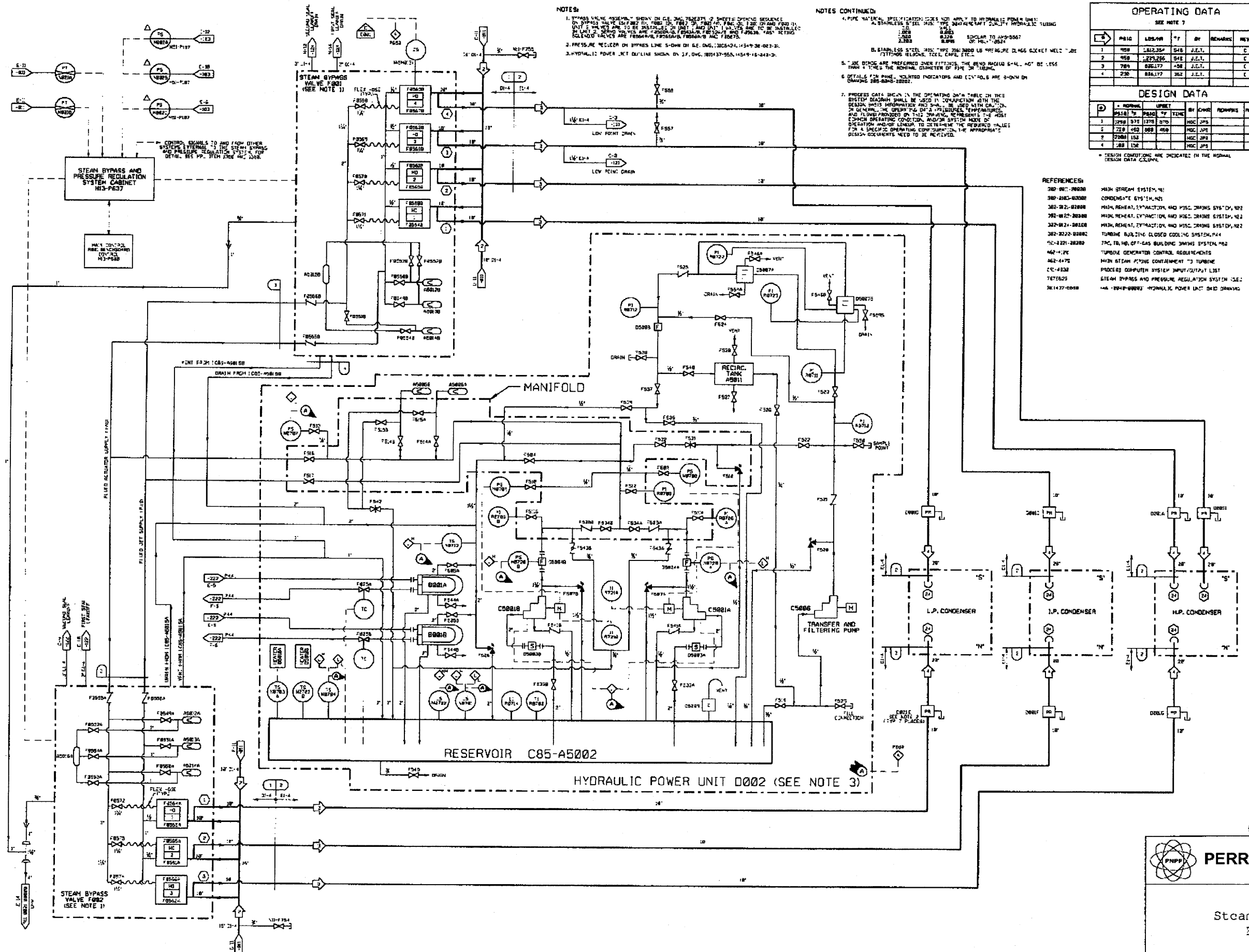

**NOTES:**

1. PRESSURE REGULATORS SHOWN ON C.E. Dwg. 7000000-2 SHEETS SHOWN IN SEQUENCE ON STEAM BYPASS VALVE F082 (1), F083 (2), F084 (3), F085 (4) AND F086 (5) UNLESS OTHERWISE NOTED. ALL VALVES ARE TO BE INSTALLED IN THE DIRECTION OF FLOW AS SHOWN IN THE DRAWING. F082, F083, F084 AND F085 ARE TO BE INSTALLED IN THE DIRECTION OF FLOW AS SHOWN IN THE DRAWING. F086 IS TO BE INSTALLED IN THE DIRECTION OF FLOW AS SHOWN IN THE DRAWING.
2. PRESSURE REGULATORS ON BYPASS LINE SHOWN ON C.E. Dwg. 7000000-2 SHEETS SHOWN IN SEQUENCE ON STEAM BYPASS VALVE F082 (1), F083 (2), F084 (3), F085 (4) AND F086 (5) UNLESS OTHERWISE NOTED.
3. HYDRAULIC POWER UNIT OUTLINE SHOWN ON C.E. Dwg. 7000000-2 SHEETS SHOWN IN SEQUENCE ON STEAM BYPASS VALVE F082 (1), F083 (2), F084 (3), F085 (4) AND F086 (5) UNLESS OTHERWISE NOTED.

**NOTES CONTINUED:**

4. PIPE MATERIAL SPECIFICATION DOES NOT APPLY TO HYDRAULIC POWER UNIT: A. STAINLESS STEEL PIPE TYPE 304/304L/316/316L HYDRAULIC TUBING B. STAINLESS STEEL PIPE TYPE 304/304L/316/316L HYDRAULIC TUBING C. STAINLESS STEEL PIPE TYPE 304/304L/316/316L HYDRAULIC TUBING D. STAINLESS STEEL PIPE TYPE 304/304L/316/316L HYDRAULIC TUBING E. STAINLESS STEEL PIPE TYPE 304/304L/316/316L HYDRAULIC TUBING F. STAINLESS STEEL PIPE TYPE 304/304L/316/316L HYDRAULIC TUBING G. STAINLESS STEEL PIPE TYPE 304/304L/316/316L HYDRAULIC TUBING H. STAINLESS STEEL PIPE TYPE 304/304L/316/316L HYDRAULIC TUBING I. STAINLESS STEEL PIPE TYPE 304/304L/316/316L HYDRAULIC TUBING J. STAINLESS STEEL PIPE TYPE 304/304L/316/316L HYDRAULIC TUBING K. STAINLESS STEEL PIPE TYPE 304/304L/316/316L HYDRAULIC TUBING L. STAINLESS STEEL PIPE TYPE 304/304L/316/316L HYDRAULIC TUBING M. STAINLESS STEEL PIPE TYPE 304/304L/316/316L HYDRAULIC TUBING N. STAINLESS STEEL PIPE TYPE 304/304L/316/316L HYDRAULIC TUBING O. STAINLESS STEEL PIPE TYPE 304/304L/316/316L HYDRAULIC TUBING P. STAINLESS STEEL PIPE TYPE 304/304L/316/316L HYDRAULIC TUBING Q. STAINLESS STEEL PIPE TYPE 304/304L/316/316L HYDRAULIC TUBING R. STAINLESS STEEL PIPE TYPE 304/304L/316/316L HYDRAULIC TUBING S. STAINLESS STEEL PIPE TYPE 304/304L/316/316L HYDRAULIC TUBING T. STAINLESS STEEL PIPE TYPE 304/304L/316/316L HYDRAULIC TUBING U. STAINLESS STEEL PIPE TYPE 304/304L/316/316L HYDRAULIC TUBING V. STAINLESS STEEL PIPE TYPE 304/304L/316/316L HYDRAULIC TUBING W. STAINLESS STEEL PIPE TYPE 304/304L/316/316L HYDRAULIC TUBING X. STAINLESS STEEL PIPE TYPE 304/304L/316/316L HYDRAULIC TUBING Y. STAINLESS STEEL PIPE TYPE 304/304L/316/316L HYDRAULIC TUBING Z. STAINLESS STEEL PIPE TYPE 304/304L/316/316L HYDRAULIC TUBING
5. ALL BEINGS ARE PREFERRED OVER FITTINGS. THE BEING RADIUS SHALL NOT BE LESS THAN 1/2 TIMES THE NOMINAL DIAMETER OF PIPE OR TUBING.
6. DETAILS FOR PIPE, WELDED INDICATORS AND COUPLERS ARE SHOWN ON DRAWING 285-8340-10002.
7. PRESSURE DATA SHOWN IN THE OPERATING DATA TABLE ON THIS SYSTEM DIAGRAM SHALL BE USED IN CONJUNCTION WITH THE DESIGN BASIS INFORMATION AND SHALL BE USED WITH CAUTION. IN GENERAL, THE OPERATING DATA TABLES, TEMPERATURES, AND PRESSURES SHOWN ON THIS DRAWING REPRESENTS THE MOST COMMON OPERATING CONDITION AND/OR SYSTEM MODE OF OPERATION AND/OR LINEAR TO DETERMINE THE REQUIRED VALUES FOR A SPECIFIC OPERATING CONDITION, THE APPROPRIATE DESIGN DOCUMENTS NEED TO BE REVIEWED.

OPERATING DATA					
SEE NOTE 7					
ID	PSIG	PSIA	°F	BY	REMARKS
1	450	146.254	540	J.E.T.	C
2	450	146.254	540	J.E.T.	C
3	780	282.177	540	J.E.T.	C
4	230	86.177	382	J.E.T.	C

DESIGN DATA					
ID	NORMAL	UPSET	BY	CHG	REMARKS
ID	PSIG	PSIA	°F	TIME	REMARKS
1	225	230	570	570	HCC JPS
2	225	230	570	570	HCC JPS
3	225	230	570	570	HCC JPS
4	225	230	570	570	HCC JPS

\* DESIGN CONDITIONS ARE INDICATED IN THE NORMAL DESIGN DATA COLUMN.

- REFERENCES:**
- 280-800-0000 MAIN STEAM SYSTEM, H1
  - 280-800-0000 CONDENSATE SYSTEM, H2
  - 280-800-0000 MAIN HEAT EXCHANGER AND MISC. DRAIN SYSTEM, H3
  - 280-800-0000 MAIN HEAT EXCHANGER AND MISC. DRAIN SYSTEM, H4
  - 280-800-0000 MAIN HEAT EXCHANGER AND MISC. DRAIN SYSTEM, H5
  - 280-800-0000 TURBINE BUILDING CLOSED COOLING SYSTEM, H6
  - 280-800-0000 TRC, TR, HD, OFF-GAS BUILDING DRAIN SYSTEM, H7
  - 280-800-0000 TURBINE GENERATOR CONTROL REQUIREMENTS
  - 280-800-0000 MAIN STEAM SYSTEM CONTAINMENT TO TURBINE
  - 280-800-0000 PROCESS COMPUTER SYSTEM INPUT/OUTPUT LIST
  - 280-800-0000 STEAM BYPASS AND PRESSURE REGULATION SYSTEM (SEE Dwg. 7000000-2)
  - 280-800-0000 HYDRAULIC POWER UNIT (SEE DRAWING)

(Rev. 14 10/05)



Steam Bypass and Pressure Regulation System

Figure 10.4-1  
(Dwg. D-302-021)

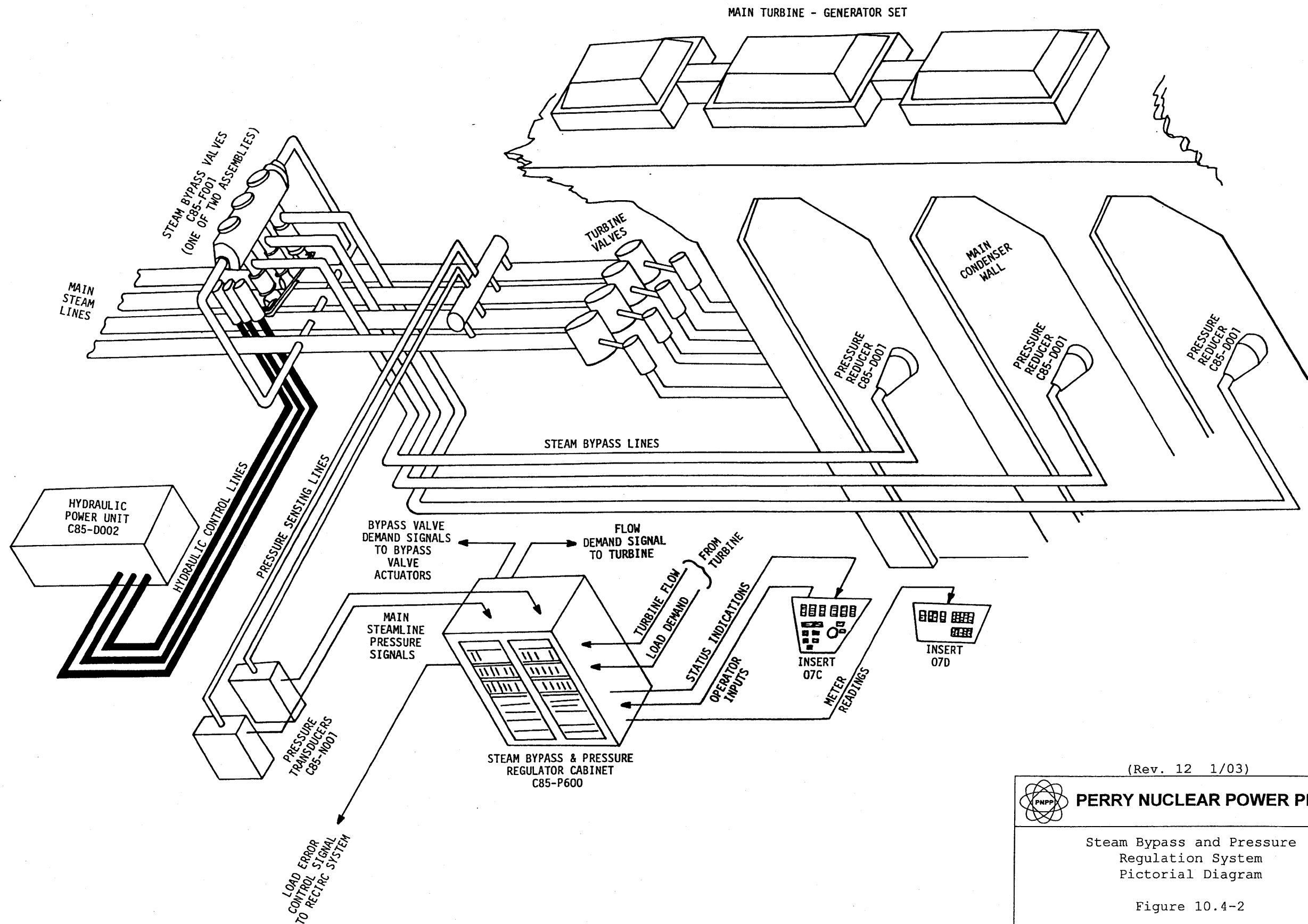

(Rev. 12 1/03)

**PERRY NUCLEAR POWER PLANT**

Steam Bypass and Pressure Regulation System Pictorial Diagram

Figure 10.4-2

NOMENCLATURE

1. Assembly
2. Bypass Casing
3. Control Pac
4. Power Actuator
8. Test Instruction
9. Hydraulic Test Valve
10. Paint Instruction
11. Head
12. Head
13. Stud
14. Nut
15. Gasket
16. Valve Seat
17. Bolt
18. Lockring
19. Gasket
20. Stand
21. Stud
22. Nut
23. Gasket
24. Bushing
25. Bushing
26. Valve
27. Stem
28. Dowel
29. Locknut
30. Retainer
31. Packing Gland
32. Grafoil Pack
33. Stem Nut
34. Pin
35. Bolt
36. Bolt
37. Stud
38. Stud
39. Stud
40. Nut
41. Dowel
42. Spring Housing
43. Spring Housing
44. Spring Housing
45. Bolt
52. Lockwasher
57. Cotter Pin
60. Flange
61. Flange
62. Flange
63. Gasket
64. Gasket
65. Gasket
66. Nut

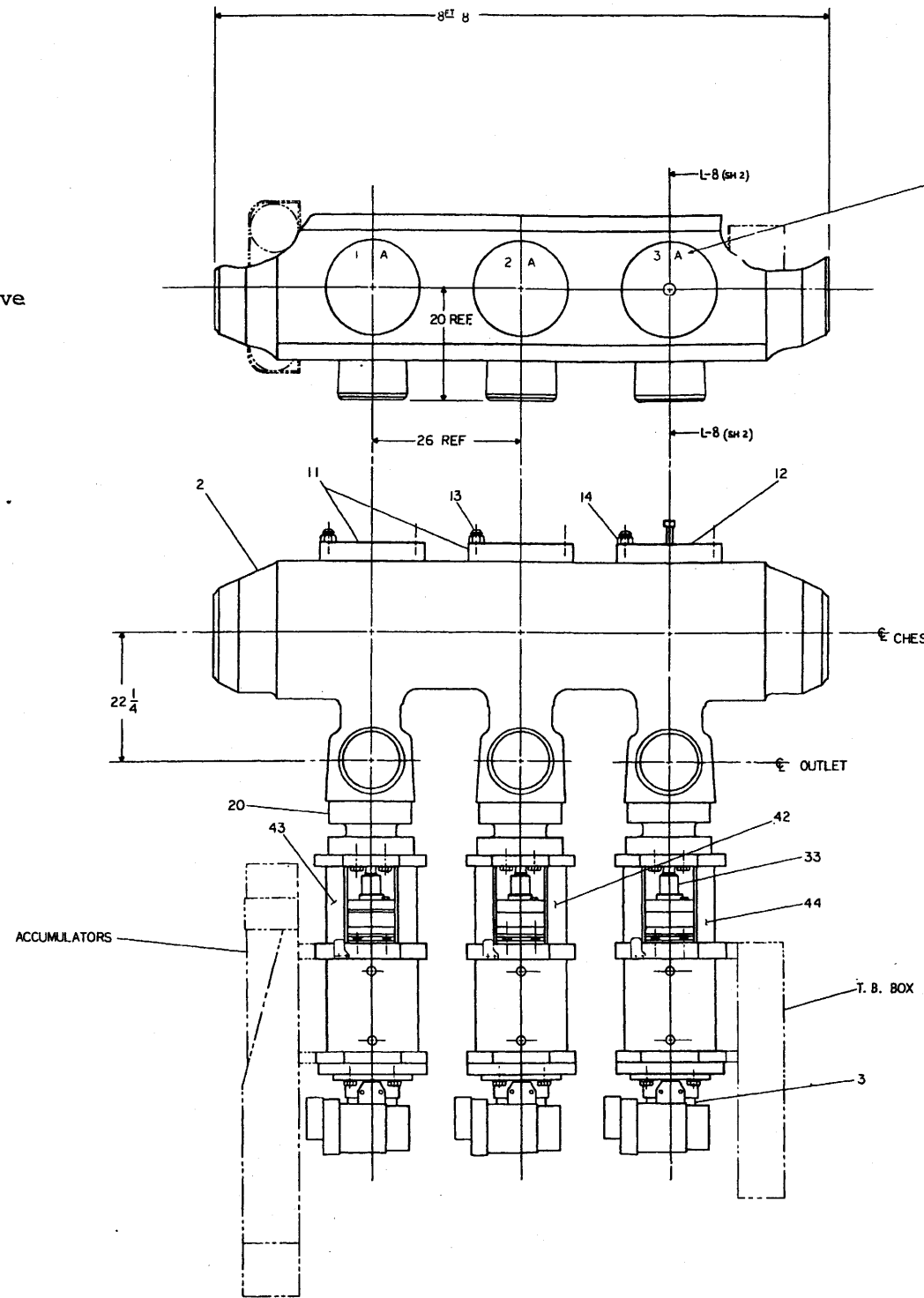

TEST DATA-FOR FACTORY USE  
 TEST # 1-AVE. NET UPWARD FORCE =  $.1728 \times 10^3$   
 TEST # 2-OPENING TIME-INDIVIDUAL VALVES =  $0.26 \text{ SEC} \pm 10\%$   
 OPENING TIME-ALL VALVES TOGETHER =  $0.27 \text{ SEC} \pm 10\%$

- (1) ASM-GI
- (8) TESTING INST.
- (9) HYDROSTATIC TEST VALVE SEAT TO 500 PSI
- (10) PAINT INST.
- (4) POWER ACTUATOR

(Rev. 12 1/03)



**PERRY NUCLEAR POWER PLANT**

Bypass Valves Chest A

Figure 10.4-3 (Sheet 1 of 2)

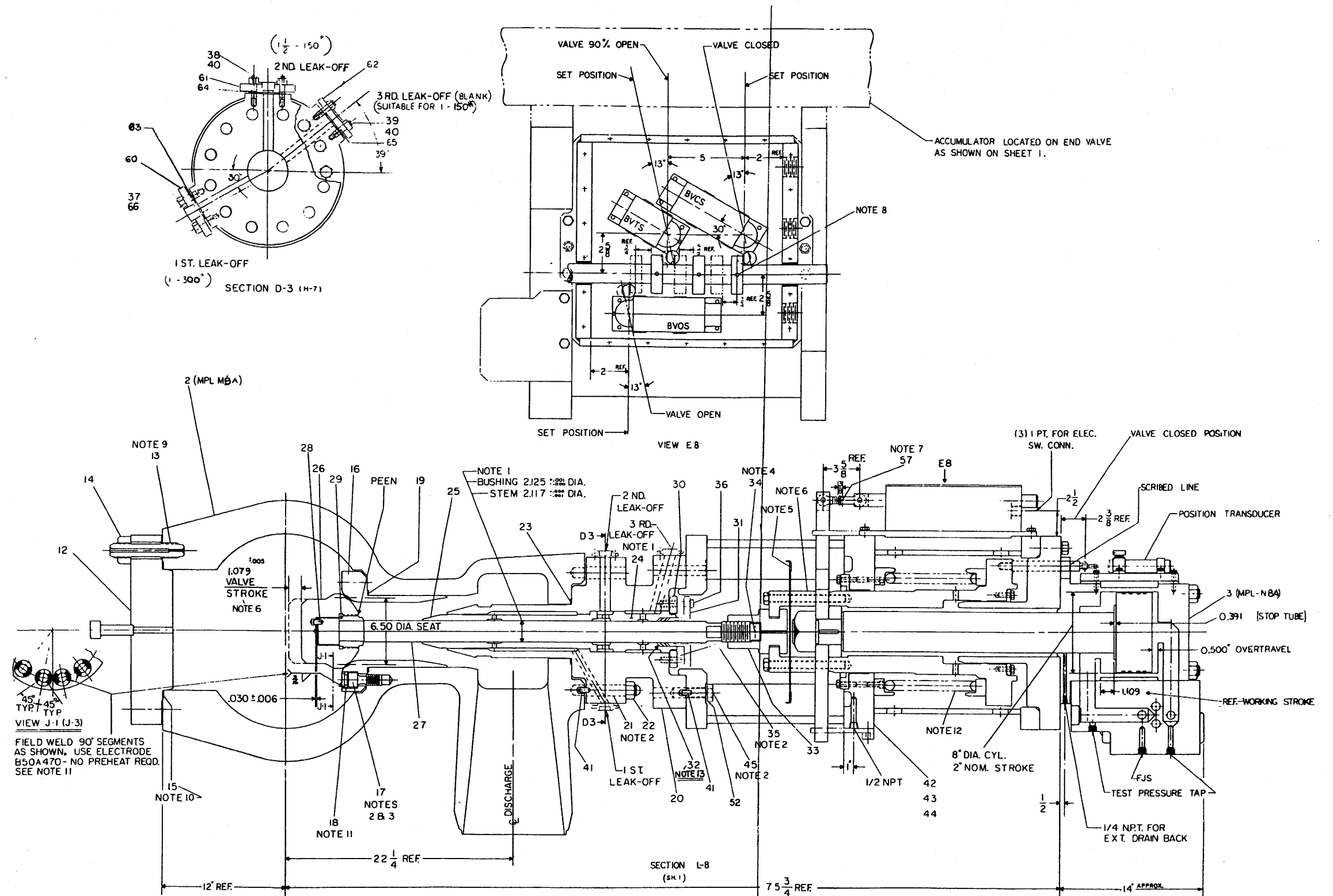

(Rev. 12 1/03)

**PERRY NUCLEAR POWER PLANT**

Bypass Valves Chest A  
 Figure 10.4-3 (Sheet 2 of 2)