

SPACE REQUIRED TO REMOVE EXCHANGER CASING

1/2" NIPPLE - PLAIN END - VENT - CUST.'S CONN.

COMPONENT COOLING WATER SUPPLY & RETURN HEADER TYPICAL

	RHR PP 1-1 SEAL WTR. CLR.	RHR PP 1-2 SEAL WTR. CLR.
SUPPLY LINE NO.	K-128-1	K-100-1
CO-OR.	106-C-14	64-C-14
RETURN LINE NO.	K-131-1	K-122-1
CO-OR.	106-C-14	64-C-14

(RHR PUMP 1-1 ONLY)

- (B) 3/4" 300# RAISED FACE FLANGE, SA-182, TP-304 - PUMPING RING OUTLET PIPED TO HEAT EXCHANGER → PRESSURE DROP 1 PSI
- 3/4" PIPE, SCH. 160, SA-376, TP-304
- (B) 3/4" 300# RAISED FACE FLANGE - PUMPING RING OUTLET PIPED TO HEAT EXCHANGER → PRESSURE DROP 1 PSI

RHR PUMP 1-2 ONLY

- (AA) 1/2" P.T. - VENT OR QUENCH
- (BA) 1/2" PT - DRAIN (GLAND DRAIN)
- (EA) 1/2" P.T. - FLUSHING CONN. - PIPED FROM HEAT EXCHANGER
- (L) 1/2" P.T. - COOLING LIQUID - IN
- (M) 1/2" P.T. - COOLING LIQUID - OUT
- (G) 1" 300# RF FLANGE - CASING DRAIN

HEAT EXCHANGER 10 G.P.M. REQUIRED

DYE PENETRATE TEST REQUIRED. ALL SEALWELDS PER PT ASME-3 NO POSTWELD HEAT TREATMENT REQUIRED.

RECIRCULATION OF LIQUID FROM SEAL WITH PUMPING RING - THRU COOLER & BACK TO SEAL.

RESIDUAL HEAT REMOVAL PUMP 1-1  
SHAFT SEAL (TYP); REF. DWG. DC-663217-25

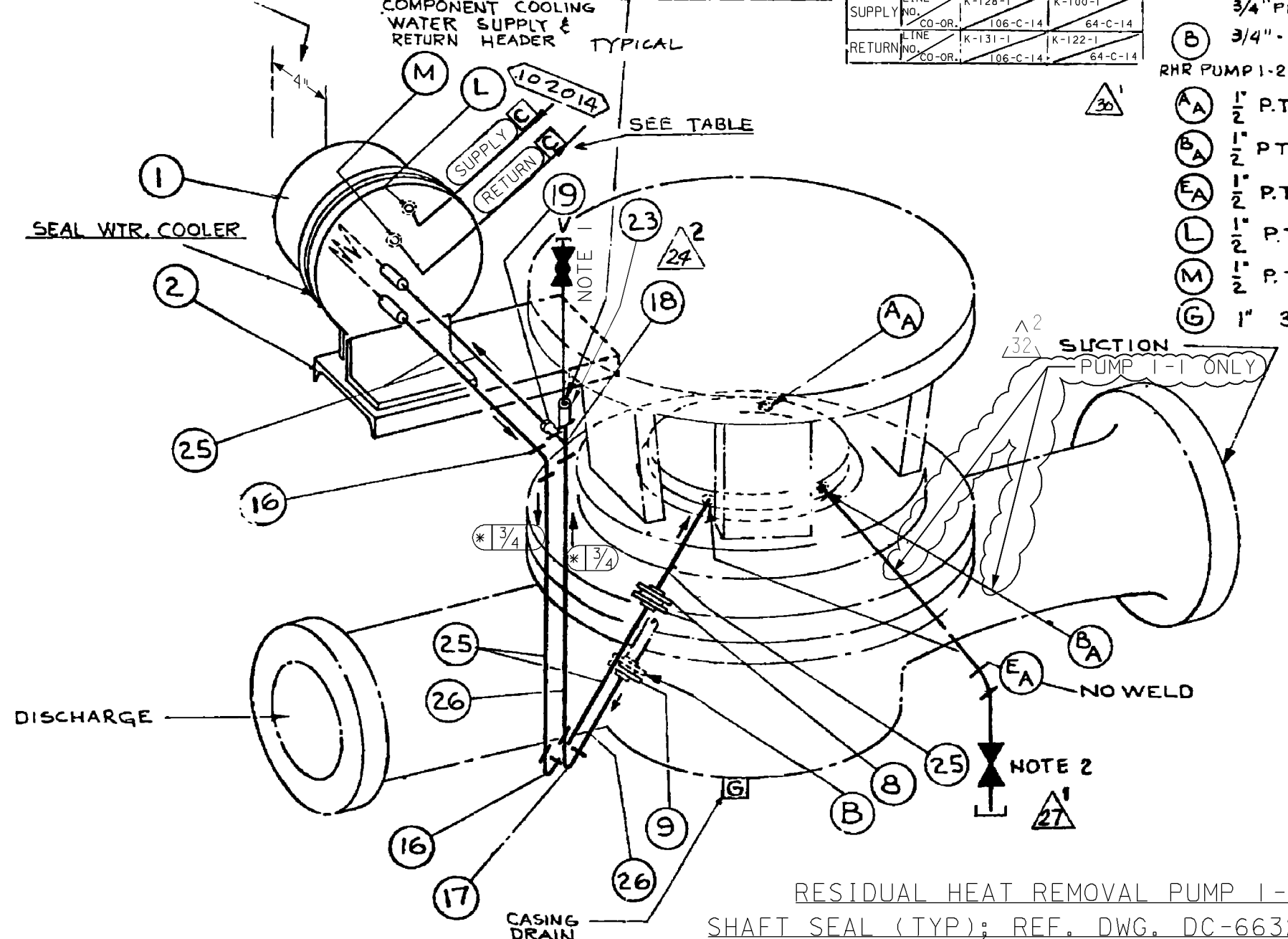

NOTE

1. PUMP 1-1, 3/4" - T58  
PUMP 1-2, ANCHOR DARLING MODEL 1878GB,  
DWG. 6006973-97, S/C. 94-2820
2. PUMP 1-1 ONLY, 3/4" - T58 (45-B)

CAD User: mlbf Date: 4-23-2004  
DGN=2010S4.DGN  
RASTER=2010S4.TIF

P G & E CO.		102010	REV. 32
SHEET 4	PAGE 0		

4/26/04	MIBF	CDP3	-	KERSI J. DALAL	MECHANICAL	M 16690	3/31/2006	Revised per FCT 028019
DATE	DWN	RE	IV	PROFESSIONAL ENGINEER	PE DISC.	PE#	PE EXP.	

INPGIC