

**MAIN TURBINE OIL RESERVOIR
VAPOR EXTRACTOR AND
DEMISTER SYSTEM**
DC-663282-1

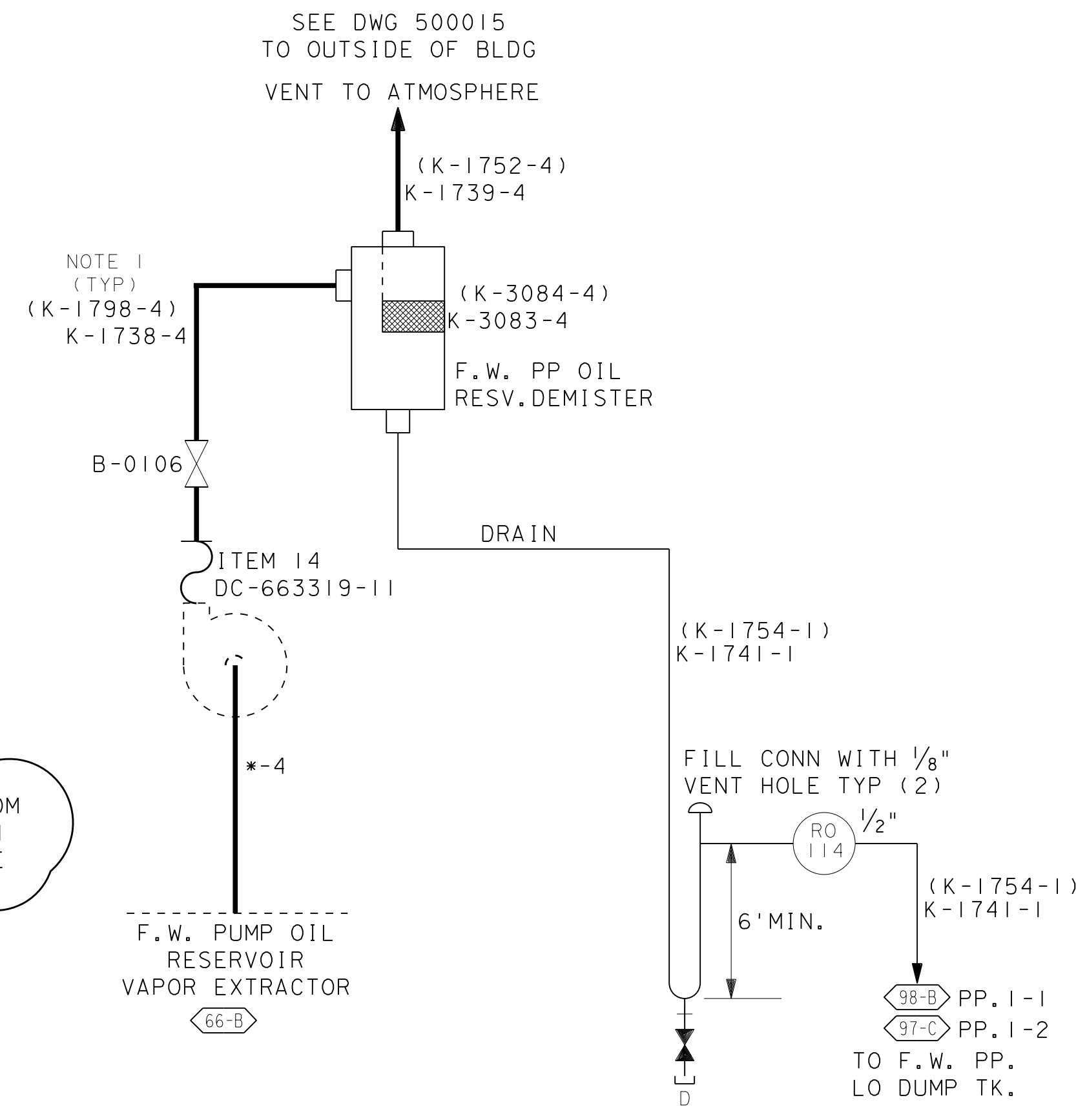

**FEEDWATER PUMP OIL
RESERVOIR I-1 VAPOR
EXTRACTOR AND DEMISTER
SYSTEM**

FOR FEEDWATER PUMP 1-2
REFER TO NOTES 1 & 2
DC-663300-5
DC-663300-11 TAB 44

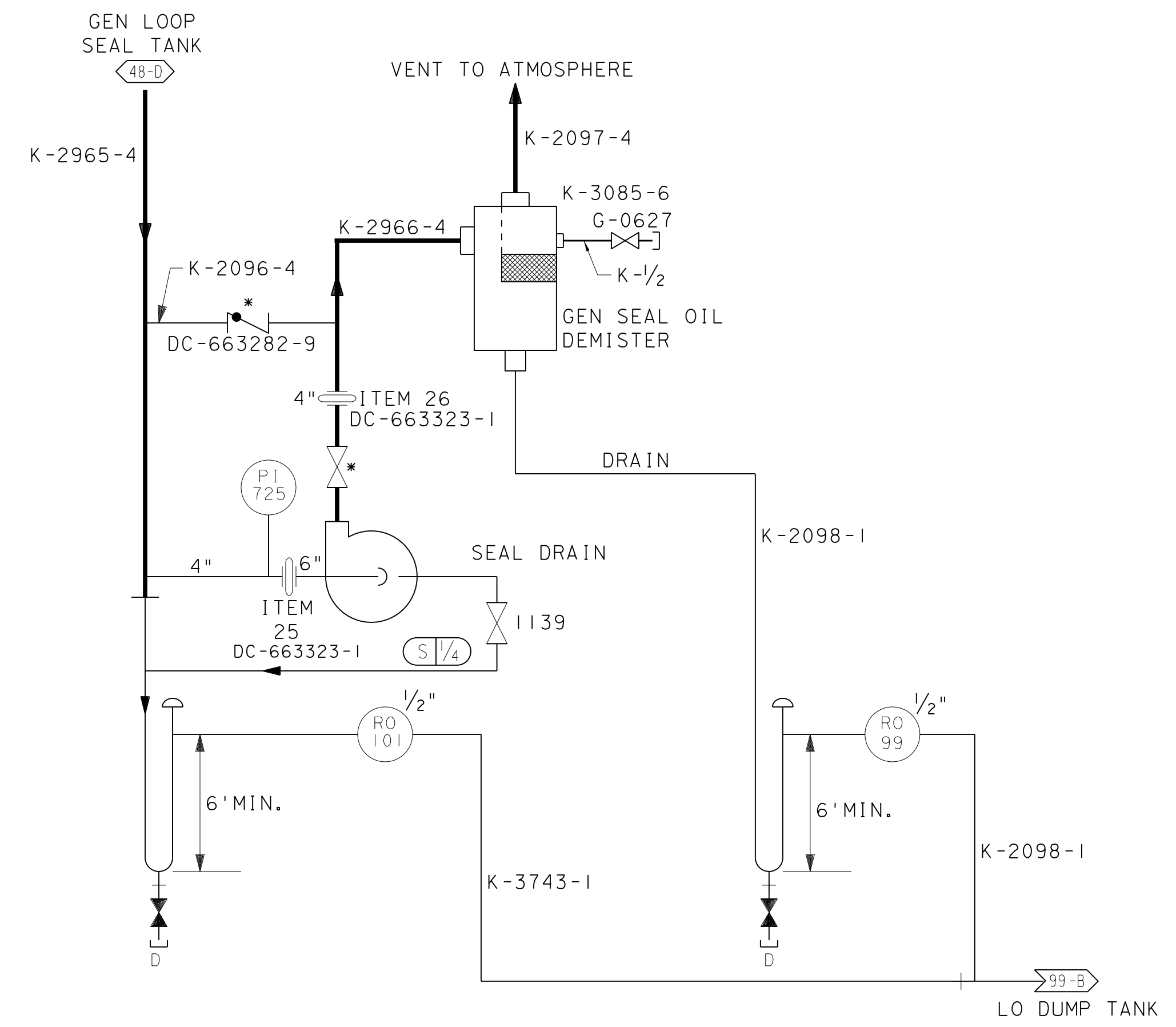

**GENERATOR LOOP SEAL OIL TANK
VAPOR EXTRACTOR AND DEMISTER
SYSTEM**
DC-663282-3

- NOTES:**
1. ALL LINE NUMBERS IN PARENTHESIS ARE FOR FEEDWATER PUMP 1-2 (53-E)
 2. INSTRUMENT NUMBERS FOR FW. PP. OIL RESERVOIR 1-2 ARE ON SHEET 7 TABLE 4 (54-B)
 3. FILL CONN WITH 1/4" VENT HOLE (52-D)
 4. 8" EXPANSION JOINT, STOCK CODE 77-6611 (51-D)
 5. FILL CONN ONLY, NO VENT HOLE (52-D)

UNIT 1

DIABLO CANYON POWER PLANT - PG&E CO.			
LUBE OIL DISTRIBUTION AND PURIFICATION SYSTEMS			
DRAWING	SHEET	PAGE	REV
102020	5	0	57

RASTER=102020-5-0.dgn
 DGN=102020-5-0.dgn
 CAD User: ZNS4 Date: 02-16-2018