

Answer Explanation

<QQ 2150323(1412)><<B is correct.

Per CPS 4008.01 Abnormal Reactor Coolant Flow, step 6.5.6.3 Core Flow Indication Guidance, when one RR Pump is running, the only valid indication of total core flow is via core plate D/P due to reverse loop/jet pump flow inaccuracies.

At 55% power and 35.8 Mlbm/hr (CORE FLOW FROM CORE PLATE DIFF PRESSURE), the reactor is operating in the controlled entry region of the power/flow operating map.

Initial conditions indicate 1 OPRM channel is INOPERABLE with no RPS or OPRM trips are present. Since the alternate method to detect and suppress thermal hydraulic instability oscillations is in effect, it can be inferred that ITS 3.3.1.3 Oscillation Power Range Monitor (OPRM) Instrumentation Action A.3 and/or B.1 is in effect.

Per CPS 3005.01 Unit Power Changes section 6.4 Stability Control Concerns and CPS 4100.02 Core Stability Control, step 4.1:

IF the CONTROLLED ENTRY REGION is entered due to an inadvertent or forced entry,
AND
ITS LCO 3.3.1.3 OPRM Required Action A.3 or B.1 are in effect [Initiate alternate method to detect and suppress thermal hydraulic instability oscillations]
THEN SCRAM the reactor.

Incorrect Responses:

A is incorrect but plausible. The first part of this response is correct. The intersection of 32.5 Mlbm/hr (TOTAL FLOW) and 55% power is in the restricted zone of the Figure 1: Stability Control & Power/Flow Operating Map. The second part of this response would be correct if TOTAL FLOW was the correct core flow to use in this case. However, the only valid indication of total core flow is via core plate D/P.

C is incorrect but plausible. This response would be correct if:

- TOTAL FLOW was the correct core flow to use on Figure 1: Stability Control & Power/Flow Operating Map, and
- inserting control rods via reverse rod sequence or CRAM RODS was the acceptable method to exit the Restricted Zone. However, this method is used to exit the Controlled Entry Region or MELLLA Limit.

D is incorrect but plausible. This response would be correct if all OPRMs were OPERABLE and ITS 3.3.1.3 OPRM Instrumentation Action A.3 and/or B.1 were not in effect.>>

Question Information

Topic	<QQ 2150323(1400)><<The following plant conditions existed: Reactor was at rated thermal power (RTP). No Reactor Prot>>				
User ID	<QQ 2150323(1404)><<CL-ILT-N19001>>		System ID	<QQ 2150323(1445)><<2150323>>	
Status	<QQ 2150323(1405)><<Active>>	Point Value	<QQ 2150323(1441)><<1.00>>	Time (min)	<QQ 2150323(1408)><<0>>

Open or Closed Reference	<QQ 2150323(1409)><<OPEN>>
Operator Type_Cognitive Level	<QQ 2150323(1415)><<RO-HIGH>>
Operator Discipline	<QQ 2150323(1413)><<LO-I>>
10CFR55 Content	<TB 479392(1305)><<CFR: 41.7 Design, components, and functions of control and safety systems, including instrumentation, signals, interlocks, failure modes, and automatic and manual features.>>

References Provided	CPS 3005.01 Unit Power Changes, Figure 1: Stability Control & Power/Flow Operating Map		
K/A Justification	Question meets the KA because the candidate must understand the loss of capability of RPS (OPRM) and its consequences with regard to a partial loss of flow to determine the correct response.		
SRO-Only Justification	N/A		
Additional Information	Question is high cog written at the analysis and application level. The candidate must analyze the parameters in the stem (including a graphic) and then determine appropriate actions based on that analysis (3-SPK/SPR).		
NRC Exams Only			
Question Type	New	Difficulty	N/A
Technical Reference and Revision #	<ul style="list-style-type: none"> • CPS 3005.01 Rev. 46 • CPS 4008.01 Rev. 20e • CPS 4100.02 Rev. 0e 		
Training Objective	DB400801.01.04 Given CPS No. 4008.01, ABNORMAL REACTOR COOLANT FLOW, describe the methods to be used to exit Controlled Entry Region.		
Previous NRC Exam Use	None		

K/A Reference(s)

<CM 240462(1002)><<295001.AA1.02> >	Safety Function 1	Tier 1	Group 1	RO Imp: 3.3	SRO Imp: 3.3
<CM 240460(1001)><<Ability to operate and/or monitor the following as they apply to PARTIAL OR COMPLETE LOSS OF FORCED CORE FLOW CIRCULATION : (CFR: 41.7 / 45.6)>> <CM 240462(1001)><<RPS>>					

Learning Objective(s)

 <OB 1537820(1101)><<Q1 295001 AA1.02 (NH)>>
 User (Sys) ID N/A (<OB 1537820(1125)><<1537820>>)

Cross Reference Links

None

Question 2	ID: 2150346	Points: 1.00
------------	-------------	--------------

<QQ 2150346(1410)><<CPS is operating at rated thermal power.

THEN, a Station Blackout (SBO) occurs.

- (1) Which Source Range Monitor (SRM) indications are accurate?
- (2) Which procedure(s) is/are required to be entered?>>

- A. <QQ 2150346(1480)><<(1) Period ONLY.
(2) CPS 4200.01, Loss of AC Power ONLY.>>
- B. <QQ 2150346(1480)><<(1) Period ONLY.
(2) CPS 4200.01, Loss of AC Power and CPS 4201.01, Loss of DC Power.>>
- C. <QQ 2150346(1480)><<(1) Period AND count rate.
(2) CPS 4200.01, Loss of AC Power ONLY.>>
- D. <QQ 2150346(1480)><<(1) Period AND count rate.
(2) CPS 4200.01, Loss of AC Power and CPS 4201.01, Loss of DC Power.>>

Answer	<QQ 2150346(1419)><<A>>
--------	-------------------------

Answer Explanation

<QQ 2150346(1412)><<A is correct.

Per CPS 4200.01, Loss of AC Power, Appendix B, and CPS 3306.01E001, SRM/IRM Electrical Lineup, the SRMs will indicate period. The drive motors are powered from AB MCC 1F (1AP41E), which is in turn powered from 480VAC Bus 1L (1AP24E) and ultimately from 6900VAC Bus 1A. The detectors are normally retracted at power and will not accurately read count rate. CPS 4200.01 is required to be entered upon "any interruption of power on an AC bus which results in loss of voltage, current and watts on the bus" per the symptoms of the procedure. A station blackout (SBO) is defined as a total loss of offsite AC power sources (including main generator), and failure of Div 1 and Div 2 DG power sources. This does not include DC sources, and entry into CPS 4201.01, Loss of DC Power would not be appropriate.

Incorrect Responses:

B is incorrect but plausible. The first part of the response is correct. However, the SBO does not include DC sources and CPS 4201.01 entry is not required. Plausible because misconception exists that SBO includes vital or non-vital DC sources as well as AC sources.

C is incorrect but plausible because power is still available to the SRMs. SRM period is still reliable. However, they will not accurately read count rate due to the detectors being retracted at power. AC power is required to insert the detectors into the core. The second part of the response is correct.

D is incorrect but plausible because power is still available to the SRMs. SRM period is still reliable.

However, they will not accurately read count rate due to the detectors being retracted at power. Additionally, the SBO does not include DC sources and CPS 4201.01 entry is not required. Plausible because misconception exists that SBO includes vital or non-vital DC sources as well as AC sources.>>

Question Information

Topic	<QQ 2150346(1400)><<CPS is at rated thermal power. THEN, a Station Blackout (SBO) occurs. (1) Which Source Rang>>				
User ID	<QQ 2150346(1404)><<CL-ILT-N19002>>			System ID	<QQ 2150346(1445)><<2150346>>
Status	<QQ 2150346(1405)><<Active>>	Point Value	<QQ 2150346(1441)><<1.00>>	Time (min)	<QQ 2150346(1408)><<0>>

Open or Closed Reference	<QQ 2150346(1409)><<CLOSED>>
Operator Type_Cognitive Level	<QQ 2150346(1415)><<RO-MEMORY>>
Operator Discipline	<QQ 2150346(1413)><<LO-I>>
10CFR55 Content	<TB 479392(1305)><<CFR: 41.7 Design, components, and functions of control and safety systems, including instrumentation, signals, interlocks, failure modes, and automatic and manual features.>>

References Provided	None
K/A Justification	Question meets the KA because the candidate must demonstrate the ability to determine how to obtain reactor power information following a complete loss of AC power.
SRO-Only Justification	N/A
Additional Information	Question is low cog written at the memory level. The candidate must recall system response (1-I).

NRC Exams Only			
Question Type	Bank (CL-LC-1521)	Difficulty	N/A
Technical Reference and Revision #	<ul style="list-style-type: none"> CPS 3306.01E001, Rev. 6 CPS 4200.01 Rev. 26c 		
Training Objective	215004.09 DISCUSS the effect: A total loss or malfunction of the Source Range Monitor System has on the plant. A total loss or malfunction of various plant systems has on the Source Range Monitor System.		

Previous NRC Exam Use	None
-----------------------	------

K/A Reference(s)

<CM 240549(1002)><<295003.AA2.02>> >	Safety Function 6	Tier 1	Group 1	RO Imp: 4.2*	SRO Imp: 4.3*
<CM 240547(1001)><<Ability to determine and/or interpret the following as they apply to PARTIAL OR COMPLETE LOSS OF A.C. POWER : (CFR: 41.10 / 43.5 / 45.13)>> <CM 240549(1001)><<Reactor power / pressure / and level>>					

Learning Objective(s)

 <OB 1537821(1101)><<Q2 295003 AA2.02 (BL)>>
 User (Sys) ID N/A (<OB 1537821(1125)><<1537821>>)

Cross Reference Links

Table: <TB 775424(1301)><<TRAINING - QUESTIONS - Track Questions Modified in this Project (CL-OPS-EXAM-ILT)>>
<TB 776704(1305)><<Tracking link in project CL-OPS-EXAM-ILT to source question 2150346>>

Question 3	ID: 2150591	Points: 1.00
------------	-------------	--------------

<QQ 2150591(1410)><<The plant is operating at rated thermal power (RTP).

THEN, 125VDC MCC 1A is de-energized due to an electrical fault.

Which of the following describes the ability of the Low Pressure Core Spray (LPCS) and Reactor Core Isolation Cooling (RCIC) systems to be operated from the Main Control Room?>>

- A. <QQ 2150591(1480)><<Both LPCS and RCIC are available.>>
- B. <QQ 2150591(1480)><<LPCS is available; RCIC is not available.>>
- C. <QQ 2150591(1480)><<RCIC is available; LPCS is not available.>>
- D. <QQ 2150591(1480)><<Both LPCS and RCIC are not available.>>

Answer	<QQ 2150591(1419)><<D>>
--------	-------------------------

Answer Explanation

<QQ 2150591(1412)><<D is correct.

Per CPS 4201.01C001 Loss Of 125VDC MCC 1A (1DC13E) Load Impact List:

- A loss of 125VDC MCC 1A causes a loss of power to multiple RCIC motor-operated valves and the LPCS pump breaker.
- Although the breakers could be manually operated if required, this renders both systems unavailable to inject from the Main Control Room (MCR).

Incorrect Responses:

A is incorrect but plausible. This answer is plausible because the LPCS and RCIC system breakers could be manually operated. However, the systems are not available to be operated from the MCR.

B is incorrect but plausible. This answer may be chosen because LPCS is available if the pump breaker was manually operated; but LPCS is not available from the MCR.

C is incorrect but plausible. This answer may be chosen since RCIC is available if the system valve breakers were manually operated; but RCIC is not available from the MCR.>>

Question Information

Topic	<QQ 2150591(1400)><<The plant is operating at rated thermal power (RTP). THEN, 125VDC MCC 1A is de-energized due to >>				
User ID	<QQ 2150591(1404)><<CL-ILT-N19003>>		System ID	<QQ 2150591(1445)><<2150591>>	
Status	<QQ 2150591(1405)><<Active>>	Point Value	<QQ 2150591(1441)><<1.00>>	Time (min)	<QQ 2150591(1408)><<0>>

Open or Closed Reference	<QQ 2150591(1409)><<CLOSED>>
Operator Type_Cognitive Level	<QQ 2150591(1415)><<RO-MEMORY>>
Operator Discipline	<QQ 2150591(1413)><<LO-I>>
10CFR55 Content	<TB 479392(1305)><<CFR: 41.7 Design, components, and functions of control and safety systems, including instrumentation, signals, interlocks, failure modes, and automatic and manual features.>>

References Provided	None
K/A Justification	Question meets the KA because it requires the candidate to determine availability of RCIC and LPCS (ESF/SR equipment) following a loss of DC power.
SRO-Only Justification	N/A
Additional Information	Question is low cog written at the memory level. The candidate must recall facts pertaining to and contained in a procedure (1-F).

NRC Exams Only			
Question Type	New	Difficulty	N/A
Technical Reference and Revision #	<ul style="list-style-type: none"> CPS 4201.01C001 Rev. 1 		
Training Objective	217000.09 DISCUSS the effect:.1 A total loss or malfunction of the REACTOR CORE ISOLATION COOLING (RI) System has on the plant..2 A total loss or malfunction of various plant systems has on the REACTOR CORE ISOLATION COOLING (RI) System.		
Previous NRC Exam Use	None		

K/A Reference(s)

<CM 275321(1002)><<B2.2.37>>	Safety Function 6	Tier 3	Group	RO Imp: 3.6	SRO Imp: 4.6
<CM 275321(1001)><<Ability to determine operability and/or availability of safety related equipment. (CFR: 41.7 / 43.5 / 45.12)>>					
<CM 246572(1002)><<GS.295004>>	Safety Function 6	Tier 1	Group 1	RO Imp:	SRO Imp:
<CM 246572(1001)><<Partial or Complete Loss of D.C. Power>>					

Learning Objective(s)

 <OB 1537822(1101)><<Q3 295004 2.2.37 (NL)>>
 User (Sys) ID N/A (<OB 1537822(1125)><<1537822>>)

Cross Reference Links

None

Question 4	ID: 2150602	Points: 1.00
------------	-------------	--------------

<QQ 2150602(1410)><<CPS is operating at rated thermal power with conditions as follows:

- Both Turbine Driven Reactor Feed Pumps (TDRFPs) are on the Master Level Controller (MLC) in Automatic
- Motor Driven Reactor Feed Pump (MDRFP) is in standby and available.

THEN, the Main Turbine tripped (cause unknown).

Which case describes the expected:

- 1) RPV level response to the transient, and
- 2) FW System response (including manual actions that must be taken, if any)?

(Note - assume any FW system responses not listed actuate correctly.)

	Case 1	Case 2	Case 3	Case 4
RPV Level Response	Lowers below Level 3 and then rises	Lowers below Level 3 and then rises	Rises above Level 8 and then lowers	Rises above Level 8 and then lowers
Expected FW System Response	TDRFP 'A' trips MDRFP auto starts TDRFP 'B' goes to zero speed MDRFP / FW004 controls RPV level in Automatic	TDRFP 'B' trips MDRFP auto starts TDRFP 'A' goes to zero speed MDRFP / FW004 controls RPV level in Automatic	Both TDRFPs trip MDRFP auto starts at ~ 50 inches MDRFP / FW004 controls RPV level in Automatic	Both TDRFPs trip MDRFP / FW004 controls RPV level in Automatic
Manual Actions Required	None	None	None	High Level trips must be manually reset before the MDRFP will start.

>>

- A. <QQ 2150602(1480)><<Case 1>>
- B. <QQ 2150602(1480)><<Case 2>>
- C. <QQ 2150602(1480)><<Case 3>>
- D. <QQ 2150602(1480)><<Case 4>>

Answer	<QQ 2150602(1419)><>
--------	-------------------------

Answer Explanation

<QQ 2150602(1412)><<B is correct.

RPV water level will lower below Level 3 as a result of the void collapse caused by the pressure transient from the Main Turbine trip and the resulting reactor scram.

Per CPS 3103.01 Feedwater (FW) Appendix G DFW Automatic Scram Sequencing. The DFW system will respond during a scram transient with 2 TDRFPs feeding and MDRFP available as follows:

- Upon receipt of low reactor water level (+8.9 in), 2 RPS signals and WR level turning (increasing), DFW will trip the B TDRFP, close 1FW002B and start the MDRFP.
- Once WR level reached 0 inches and rising, the 1FW004 will transfer to AUTO, A TDRFP will go to zero speed, 1FW002A will close and 1FW010A will fully open.
- Reactor water level will control on 1FW004 at 20 inches NR setpoint.

Incorrect Responses:

A is incorrect but plausible. Per CPS 3103.01 Appendix G, DFW trips the 'B' TDRFP, not the 'A' TDRFP, if both TDRFPs are feeding with the MDRFP available. Plausible due to misconception that it is preferred to operate the 'B' TDRFP (much like the "B' RHR pump for shutdown cooling).

C is incorrect but plausible. Multiple SRVs will lift when the turbine trips (which will cause RPV level to swell), but the swell effect lags the scram and is overridden by the shrink caused by the pressure transient and the scram. This distracter is also incorrect in that Level 8 trips must be manually reset for the MDRFP to automatically start.

D is incorrect but plausible. Multiple SRVs will lift when the turbine trips (which will cause RPV level to swell), but the swell effect lags the scram and is overridden by the shrink caused by the pressure transient and the scram.>>

Question Information

Topic	<QQ 2150602(1400)><<CPS is operating at rated thermal power with conditions as follows: Both Turbine Driven Reactor >>				
User ID	<QQ 2150602(1404)><<CL-ILT-N19004>>			System ID	<QQ 2150602(1445)><<2150602>>
Status	<QQ 2150602(1405)><<Active>>	Point Value	<QQ 2150602(1441)><<1.00>>	Time (min)	<QQ 2150602(1408)><<0>>

Open or Closed Reference	<QQ 2150602(1409)><<CLOSED>>
Operator Type_Cognitive Level	<QQ 2150602(1415)><<RO-HIGH>>
Operator Discipline	<QQ 2150602(1413)><<LO-I>>
10CFR55 Content	<TB 479390(1305)><<CFR: 41.5 Facility operating characteristics during steady state and transient conditions, including coolant chemistry, causes and effects of temperature, pressure and reactivity changes, effects of load changes, and operating limitations and reasons for these operating characteristics.>>

References Provided	None
K/A Justification	Question meets the KA because the candidate must demonstrate the ability to determine feedwater system response (automatic operations that include pump trips) based on the conditions presented in the stem to answer this question.
SRO-Only Justification	N/A
Additional Information	Question is high cog written at the analysis and application level. The candidate must analyze the parameters in the stem and then determine plant responses based on that analysis (3-SPK).

NRC Exams Only			
Question Type	Bank (CL-ILT-N14039)	Difficulty	N/A
Technical Reference and Revision #	<ul style="list-style-type: none"> CPS 3103.01 rev 34 		
Training Objective	259001.09 Initial: From memory, unless otherwise stated, in accordance with the course reference materials and procedures, the trainee shall: be able to: DISCUSS the effect: <ul style="list-style-type: none"> .1 A total loss or malfunction of the FEEDWATER System has on the plant..2 A 		

	total loss or malfunction of the various plant systems has on the FEEDWATER System
Previous NRC Exam Use	ILT 14-1 NRC

K/A Reference(s)

<CM 240621(1002)><<295005.AK1.03>>	Safety Function 3	Tier 1	Group 1	RO Imp: 3.5	SRO Imp: 3.7
<CM 240618(1001)><<Knowledge of the operational implications of the following concepts as they apply to MAIN TURBINE GENERATOR TRIP : (CFR: 41.8 to 41.10)>> <CM 240621(1001)><<Pressure effects on reactor level>>					

Learning Objective(s)

 <OB 1537823(1101)><<Q4 295005 AK1.03 (BH)>>
 User (Sys) ID N/A (<OB 1537823(1125)><<1537823>>)

Cross Reference Links

Table: <TB 775424(1301)><<TRAINING - QUESTIONS - Track Questions Modified in this Project (CL-OPS-EXAM-ILT)>>
<TB 776744(1305)><<Tracking link in project CL-OPS-EXAM-ILT to source question 2150602>>

Question 5	ID: 2155062	Points: 1.00
------------	-------------	--------------

<QQ 2155062(1410)><<A reactor plant startup is in progress.

- Reactor power is 45%.
- The MDRFP is out of service.

A loss of Main condenser vacuum is in progress.

If vacuum continues to decay, and NO operator action is taken, which ONE of the following will scram the Reactor first?>>

- A. <QQ 2155062(1480)><<MSIV closure>>
- B. <QQ 2155062(1480)><<RPV Low Level 3>>
- C. <QQ 2155062(1480)><<RPV high pressure>>
- D. <QQ 2155062(1480)><<Turbine Stop Valve closure>>

Answer	<QQ 2155062(1419)><<D>>
--------	-------------------------

Answer Explanation

<QQ 2155062(1412)><<D is correct.

Per CPS 4004.02 Loss of Vacuum, the main turbine will trip at 21.6 " Hg vac.

Per CPS 5004.01 Alarm Panel 5004 Annunciators - Row 1, annunciator 5004-1D Division 1 or 4 Turbine Stop Valve Closure Trip may be caused by a turbine trip.

Per CPS 3305.01 Reactor Protective System (RPS), Appendix A: RPS Trip Set Points, the Turbine Stop Valve (TSV) closure will cause a RPS trip and reactor scram. However, RPS trip is bypassed when < 33.3% rated thermal power (RTP).

Since Reactor power is 45% (>33.3%), a main turbine will trip at 21.6 " Hg vac will cause a RPS trip and reactor scram.

Incorrect Responses:

A is incorrect but plausible. Per CPS 4004.02, a Group 1 isolation occurs at 8.5" Hg vacuum. Plausible because a Group 1 Isolation shuts all Main Steam Isolation Valves (MSIVs) and per CPS 3305.01, MSIV closure will cause a RPS trip and reactor scram.

B is incorrect but plausible. Per CPS 3103.01 Feedwater (FW), TDRFP(s) supply feedwater to the RPV. will continue to feed the vessel until MSIVs close. A Group 1 isolation at 8.5" Hg vacuum or a Rx Feed Pump Turbine trip at 18.5" Hg vacuum would preclude the TDRFP(s) from supplying feedwater to the RPV. Plausible because a loss of feedwater allowing RPV level to fall below Level 3 will cause a RPS trip and reactor scram.

C is incorrect but plausible. Per CPS 3105.04 Steam Bypass and Pressure Regulator (SB), Steam Bypass valves help control reactor pressure by taking steam from the main steam equalizing header and direct it around the turbine to the main condenser. A Group 1 isolation at 8.5" Hg vacuum or a Bypass valve inhibit signal at 7.5" Hg vac would preclude the Steam Bypass valves from controlling RPV pressure. Plausible because a loss of pressure control allowing RPV pressure to exceed 1065 psig will cause a RPS trip and reactor scram.>>

Question Information

Topic	<QQ 2155062(1400)><<A reactor plant startup is in progress. Reactor power is 45%. The MDRFP is out of service. A I>>				
User ID	<QQ 2155062(1404)><<CL-ILT-N19005>>			System ID	<QQ 2155062(1445)><<2155062>>
Status	<QQ 2155062(1405)><<Active>>	Point Value	<QQ 2155062(1441)><<1.00>>	Time (min)	<QQ 2155062(1408)><<0>>

Open or Closed Reference	<QQ 2155062(1409)><<CLOSED>>
Operator Type_Cognitive Level	<QQ 2155062(1415)><<RO-MEMORY>>
Operator Discipline	<QQ 2155062(1413)><<LO-I>>
10CFR55 Content	<TB 479395(1305)><<CFR: 41.10 Administrative, normal, abnormal, and emergency operating procedures for the facility.>>

References Provided	None
K/A Justification	Question meets the KA because the candidate must demonstrate knowledge of turbine trip logic and how it causes a reactor scram during a lowering main condenser vacuum event.
SRO-Only Justification	N/A
Additional Information	Question is low cog written at the memory level. The candidate must recall facts pertaining to and contained in a procedure (1-F).

NRC Exams Only			
Question Type	Bank (CL-ILT-1171)	Difficulty	N/A
Technical Reference and Revision #	<ul style="list-style-type: none"> • CPS 3103.01 Rev. 34 • CPS 3105.04 Rev. 15d • CPS 3305.01 Rev. 12c • CPS 4004.02 Rev. 7a • CPS 5004.01 (1D) Rev. 28d 		

Training Objective	245000.05 Discuss the MAIN TURBINE (TG) system automatic functions/interlocks including purpose, signals, set points, sensing points, when bypassed, how/when they are.
Previous NRC Exam Use	None

K/A Reference(s)

<CM 240665(1002)><<295006.AK2.04>>	Safety Function 1	Tier 1	Group 1	RO Imp: 3.6	SRO Imp: 3.7
<CM 240661(1001)><<Knowledge of the interrelations between SCRAM and the following: (CFR: 41.7 / 45.8)>> <CM 240665(1001)><<Turbine trip logic: Plant-Specific>>					

Learning Objective(s)

 <OB 1537824(1101)><<Q5 295006 AK2.04 (BL)>>
 User (Sys) ID N/A (<OB 1537824(1125)><<1537824>>)

Cross Reference Links

None

Question 6	ID: 2161283	Points: 1.00
------------	-------------	--------------

<QQ 2161283(1410)><<Due to a fire, the Main Control Room (MCR) is required to be evacuated.

The _____(1)_____ CRO will report to the Remote Shutdown Panel (RSP) and establish plant control using the _____(2)_____.>>

- A. <QQ 2161283(1480)><<(1) 'A'
(2) Feedwater system and Main Steam Line (MSL) Drains>>
- B. <QQ 2161283(1480)><<(1) 'B'
(2) Feedwater system and Main Steam Line (MSL) Drains>>
- C. <QQ 2161283(1480)><<(1) 'A'
(2) Reactor Core Isolation Cooling (RCIC) system and Safety Relief Valves (SRVs)>>
- D. <QQ 2161283(1480)><<(1) 'B'
(2) Reactor Core Isolation Cooling (RCIC) system and Safety Relief Valves (SRVs)>>

Answer	<QQ 2161283(1419)><<C>>
--------	-------------------------

Answer Explanation

<QQ 2161283(1412)><<C is correct.

Per CPS 4003.01 Remote Shutdown (RS), the 'A CRO' reports to the Remote Shutdown Panel (RSP) and establishes plant control per section 4.2.2 MCR Evacuation and Critical Assignments.

Per CPS 4003.01H003 RSP - HARD CARD 'A', the 'A CRO' establishes RPV level control using Reactor Core Isolation Cooling (RCIC) - preferred. Per CPS 4003.01C001 RSP - Pressure Control the 'A CRO' will control RPV pressure and cooldown by varying RCIC flow rate and operating Div 1/Div 2 Safety Relief Valve (SRV) solenoid controls (Div 1 preferred over Div 2).

Additionally, per CPS 4003.01 Remote Shutdown (RS), section 4.2.1 Initial MCR Actions prior to MCR evacuation:

- The FW system is secured by the 'A CRO' using CPS 4003.01H001 - "A" CRO HARD CARD and the "B" CRO using 4003.01H002 MCR - "B" CRO HARD CARD.
- The MSIVs and MSL Drains are closed by the 'B CRO' using CPS 4003.01H002 MCR - "B" CRO HARD CARD.

Incorrect Responses:

A is incorrect but plausible. The first part of the response is correct. The second part of the response is plausible because the feedwater system and Main Steam Line (MSL) drains are normal RPV level and pressure control systems. However, they are overridden by CPS 4003.01H001 and CPS 4003.01 H002 during CPS 4003.01 Remote Shutdown (RS), section 4.2.1 Initial MCR Actions.

B is incorrect but plausible. This response is plausible because:

- both the 'A CRO' and 'B CRO' are dispatched to perform duties outside the MCR, AND
- the feedwater system and Main Steam Line (MSL) drains are normal RPV level and pressure control systems.

D is incorrect but plausible. The first part of the response is plausible because both the 'A CRO' and 'B CRO' are dispatched to perform duties outside the MCR. However, the 'A CRO' is specifically designated by CPS 4003.01 to take control at the RSP. The second part of the response is correct.>>

Question Information

Topic	<QQ 2161283(1400)><<Due to a fire, the Main Control Room (MCR) is required to be evacuated. The ____ (1) ____ CRO >>				
User ID	<QQ 2161283(1404)><<CL-ILT-N19006>>			System ID	<QQ 2161283(1445)>><<2161283>>
Status	<QQ 2161283(1405)>><<Active>>	Point Value	<QQ 2161283(1441)>><<1.00>>	Time (min)	<QQ 2161283(1408)>><<0>>

Open or Closed Reference	<QQ 2161283(1409)><<CLOSED>>
Operator Type_Cognitive Level	<QQ 2161283(1415)><<RO-MEMORY>>
Operator Discipline	<QQ 2161283(1413)><<LO-I>>
10CFR55 Content	<TB 479393(1305)><<CFR: 41.8 Components, capacity, and functions of emergency systems.>>

References Provided	None
K/A Justification	Question meets the KA because the candidate must demonstrate the ability to perform tasks outside the MCR (i.e., at the RSP) during an emergency requiring control room abandonment.
SRO-Only Justification	N/A
Additional Information	Question is low cog written at the memory level - requires recall of 4003.01 procedure steps (1-P).

NRC Exams Only			
Question Type	Bank (CL-ILT-A14017)	Difficulty	N/A
Technical Reference and Revision #	<ul style="list-style-type: none"> • CPS 4003.01 Rev. 18a • CPS 4003.01H001 Rev. 0 • CPS 4003.01H002 Rev. 0a 		

	<ul style="list-style-type: none"> • CPS 4003.01H003 Rev. 0c • CPS 4003.01C001 Rev. 0a
Training Objective	(400301.04) Evaluate plant conditions and take actions specified in CPS No. 4003.01 Remote Shutdown for those actions that DO Require MCR Evacuation.
Previous NRC Exam Use	None

K/A Reference(s)

<CM 242002(1002)><<B2.4.34>>	Safety Function 1	Tier 3	Group	RO Imp: 4.2	SRO Imp: 4.1
<CM 242002(1001)><<Knowledge of RO tasks performed outside the main control room during an emergency and the resultant operational effects. (CFR: 41.10 / 43.5 / 45.13)>>					
<CM 246584(1002)><<GS.295016>>	Safety Function 7	Tier 1	Group 1	RO Imp:	SRO Imp:
<CM 246584(1001)><<Control Room Abandonment>>					

Learning Objective(s)

 <OB 1537825(1101)><<Q6 295016 2.4.34 (BL)>>
 User (Sys) ID N/A (<OB 1537825(1125)><<1537825>>)

Cross Reference Links

None

Question 7	ID: 2150606	Points: 1.00
------------	-------------	--------------

<QQ 2150606(1410)><<CPS is operating at rated thermal power.

THEN, Component Cooling Water (CCW) Storage Tank level drops to 20".

With NO operator action, which of the following describes the plant response?>>

- A. <QQ 2150606(1480)><<The Fuel Pool Cooling (FC) Pumps will trip immediately at < 12.2 gpm of CCW flow.>>
- B. <QQ 2150606(1480)><<The Chill Water (WO) chiller will trip due to low cooling water pressure at < 50 psig.>>
- C. <QQ 2150606(1480)><<The Reactor Water Cleanup (RT) Pumps will trip when RT filter/demineralizers isolate.>>
- D. <QQ 2150606(1480)><<The Reactor Recirculation (RR) Pumps will trip after 60 seconds, causing a subsequent reactor scram.>>

Answer	<QQ 2150606(1419)><<C>>
--------	-------------------------

Answer Explanation

<QQ 2150606(1412)><<C is correct.

Per CPS 5040.01 ALARM PANEL 5040 ANNUNCIATORS - ROW 1 (1B), the CCW pumps trip when CCW Storage Tank level lowers to 24".

Since CCW supplies cooling water to the RT filter demineralizers, inlet temperatures will rise when CCW pumps trip.

Per CPS 5000.01 (1C) F-D INLET TEMP HI 140°F, all running RT pumps trip when RT filter/demineralizer temperature reaches 140°F.

Incorrect Responses:

A is incorrect but plausible. Per CPS 5040.01 ALARM PANEL 5040 ANNUNCIATORS - ROW 1 (1D), the FC pumps trip at <12.2gpm of CCW flow, but not immediately as stated in the distractor. There is a 100 second delay prior to pump trip.

B is incorrect but plausible. Per CPS 5042.08 ALARM PANEL 5042 ANNUNCIATORS - ROW 8 (8A), the WO chiller will trip at the given setpoint, but it is cooled by Service Water, not CCW.

D is incorrect but plausible. Per CPS 5040.01 ALARM PANEL 5040 ANNUNCIATORS - ROW 1 (1B), securing the RR pumps within 60 seconds is an operator immediate action, not automatic.>>

Question Information

Topic	<QQ 2150606(1400)><<CPS is operating at rated thermal power. THEN, Component Cooling Water (CCW) Storage Tank leve>>				
User ID	<QQ 2150606(1404)><<CL-ILT-N19007>>		System ID	<QQ 2150606(1445)><<2150606>>	
Status	<QQ 2150606(1405)><<Active>>	Point Value	<QQ 2150606(1441)><<1.00>>	Time (min)	<QQ 2150606(1408)><<0>>

Open or Closed Reference	<QQ 2150606(1409)><<CLOSED>>
Operator Type_Cognitive Level	<QQ 2150606(1415)><<RO-HIGH>>
Operator Discipline	<QQ 2150606(1413)><<LO-I>>
10CFR55 Content	<TB 479389(1305)><<CFR: 41.4 Secondary coolant and auxiliary systems that affect the facility.>>

References Provided	None
K/A Justification	Question meets the KA because the candidate must determine which system loads will be lost upon a complete loss of Component Cooling Water.
SRO-Only Justification	N/A
Additional Information	Question is high cog written at the comprehension level. The candidate must determine from the conditions given that the CCW pumps trip and then recognize how that affects the RT system (2-RI).

NRC Exams Only			
Question Type	New	Difficulty	N/A
Technical Reference and Revision #	<ul style="list-style-type: none"> • CPS 5000.01 (1C) Rev. 26a • CPS 5040.01 (1B, 1D) Rev. 28d • CPS 5042.08 (8A) Rev. 27b 		
Training Objective	400001.09DISCUSS the effect: a. A total loss or malfunction of the Component Cooling Water System has on the plant. A total loss or malfunction of various plant systems has on the Component Cooling Water System. .1 Loss of Component Cooling Water on CC loads (including RR pump seals) .2 Loss of DC power		

	.3 .4 .5 .6 .7	Loss of Service Water (WS) Loss of SA/IA Loss of Makeup Condensate (MC) Contaminating the CC System with lake water Contaminating the SX System with CC System water
Previous NRC Exam Use	None	

K/A Reference(s)

<CM 241009(1002)><<295018.AK2.01>>	Safety Function 8	Tier 1	Group 1	RO Imp: 3.3	SRO Imp: 3.4
<CM 241008(1001)><<Knowledge of the interrelations between PARTIAL OR COMPLETE LOSS OF COMPONENT COOLING WATER and the following: (CFR: 41.7 / 45.8)>> <CM 241009(1001)><<System loads>>					

Learning Objective(s)

 <OB 1537826(1101)><<Q7 295018 AK2.01 (NH)>>
 User (Sys) ID N/A (<OB 1537826(1125)><<1537826>>)

Cross Reference Links

None

Question 8	ID: 2151121	Points: 1.00
------------	-------------	--------------

<QQ 2151121(1410)><<The plant is operating at rated thermal power.

THEN, annunciator 5041-4C LOW PRESS CONTROL BLDG IA RING HDR is received.

- NO other ring header low pressure annunciators were received or are alarming.

Automatic actuations have occurred to maintain air supply to which of the following systems/components?

System / Component #	Description
1	Spent Fuel Pool Gate Seals
2	Scram Discharge Volume Vent and Drain Valves
3	Main Steam Isolation Valves
4	Continuous Containment Purge Ventilation (CCP) System

>>

- A. <QQ 2151121(1480)><<1 ONLY>>
- B. <QQ 2151121(1480)><<1 AND 2 ONLY>>
- C. <QQ 2151121(1480)><<1, 2, AND 3 ONLY>>
- D. <QQ 2151121(1480)><<1, 2, 3, AND 4>>

Answer	<QQ 2151121(1419)><<C>>
--------	-------------------------

Answer Explanation

<QQ 2151121(1412)><<C is correct:

Per CPS 5041.04 (4C) Low Pressure Control Building IA Ring Header, low air pressure of 70 psig to the Control Building IA header will result in automatic closure of 11A022 and 11A021, Control Bldg IA Ring Header Isolation Valves, resulting a loss of air to:

- CNMT/Drywell Purge (VR/VQ)
- Fuel Bldg (VF)
- Aux Bldg (VA)
- Turbine Bldg (VT)
- Machine Shop (VJ)
- Laboratory (VL)
- Radwaste Bldg (VW)
- Makeup Air portion of Diesel Generator (VD)
- Plant Chilled Water (WO) Chillers shutdown. The makeup valve to the WO Compression Tank fails open & lifts the WO relief valve.
- CCW Storage Tank Automatic Makeup Water Valve will fail closed.

Per CPS 3214.01 Plant Air (IA & SA), section 8.1.2.13, Figure 1, and M05-1048-9, the Spent Fuel Pool / Transfer Pool and Cask Washdown Gate Seals are supplied by the Aux and Fuel Building Service Air system and is unaffected by closure of IA022 and 1IA021, Control Bldg IA Ring Header.

The Scram Discharge Volume Vent and Drain Valves are supplied from Containment Building IA which is fed from Aux/Fuel Building IA and Turbine Building IA ring headers. Per CPS 3214.01 Figure 1, these ring headers are not equipped with automatic ring header isolation valves, so automatic isolation of 1IA021 and 1IA022 will have no impact on the Containment Building IA supply.

The Main Steam Isolation Valves are supplied from Containment Building IA which is fed from Aux/Fuel Building IA and Turbine Building IA ring headers. Per CPS 3214.01 Plant Air (IA & SA) Figure 1, these ring headers are not equipped with automatic ring header isolation valves, so automatic isolation of 1IA021 and 1IA022 will have no impact on the Containment Building IA supply.

Incorrect Responses:

A is incorrect but plausible because it is partially correct. The Spent Fuel Pool Gate Seals are unaffected by the conditions in the stem, but the Scram Discharge Volume Vent and Drain Valves and the Main Steam Isolation Valves are also unaffected.

B is incorrect but plausible because it is partially correct. The Spent Fuel Pool Gate Seals and the Scram Discharge Volume Vent and Drain Valves are unaffected by the conditions in the stem, but the Main Steam Isolation Valves are also unaffected.

D is incorrect but plausible. This answer may be chosen since some plant ventilation systems do not isolate on a loss of IA (e.g. VC, VG, VP); however, this loss of IA to the CCP system will result in an automatic system shutdown (air supply is not maintained).>>

Question Information

Topic	<QQ 2151121(1400)><<The plant is operating at rated thermal power. THEN, annunciator 5041-4C LOW PRESS CONTROL BLDG >>				
User ID	<QQ 2151121(1404)><<CL-ILT-N19008>>			System ID	<QQ 2151121(1445)><<2151121>>
Status	<QQ 2151121(1405)><<Active>>	Point Value	<QQ 2151121(1441)><<1.00>>	Time (min)	<QQ 2151121(1408)><<0>>

Open or Closed Reference	<QQ 2151121(1409)><<CLOSED>>
Operator Type_Cognitive Level	<QQ 2151121(1415)><<RO-HIGH>>
Operator Discipline	<QQ 2151121(1413)><<LO-I>>
10CFR55 Content	<TB 479390(1305)><<CFR: 41.5 Facility operating characteristics during steady state and transient conditions, including coolant chemistry, causes and effects of temperature, pressure and reactivity changes, effects of load changes, and operating limitations and reasons for these operating characteristics.>>

References Provided	None
K/A Justification	Question meets the KA because the candidate must determine the reason for the automatic isolation of the Control Building Instrument Air Header Isolation Valves (maintain air supply to various equipment supplied from the SA/IA system) to answer the question.
SRO-Only Justification	N/A
Additional Information	Question is high cog, written at the analysis and comprehension level. The candidate must analyze the indications provided in the stem and determine the effect that loss of air has on various plant systems (2-RI).

NRC Exams Only			
Question Type	Bank (CL-ILT-N15007)	Difficulty	N/A
Technical Reference and Revision #	<ul style="list-style-type: none"> CPS 5041.04 (4C) Rev. 27 CPS 3214.01 Rev. 27c 		
Training Objective	300000.09 Discuss the effects: a. A total loss or malfunction of the Service and Instrument Air System has on the plant. b. A total loss or malfunction of various plant systems has on the Service and Instrument Air System.		
Previous NRC Exam Use	ILT 15-1 NRC		

K/A Reference(s)

<CM 241052(1002)><<295019.AK3.03>>	Safety Function 8	Tier 1	Group 1	RO Imp: 3.2	SRO Imp: 3.2
<CM 241049(1001)><<Knowledge of the reasons for the following responses as they apply to PARTIAL OR COMPLETE LOSS OF INSTRUMENT AIR : (CFR: 41.5 / 45.6)>> <CM 241052(1001)><<Service air isolations: Plant-Specific>>					

Learning Objective(s)

 <OB 1537827(1101)><<Q8 295019 AK3.03 (BH)>>
 User (Sys) ID N/A (<OB 1537827(1125)><<1537827>>)

Cross Reference Links

None

Question 9	ID: 2166696	Points: 1.00
------------	-------------	--------------

<QQ 2166696(1410)><<The plant is performing a shutdown in preparation for a maintenance outage. RHR Pump 'B' is operating in Shutdown Cooling Mode. THEN, RPV level LOWERED to +5.0 inches.

What is the expected plant response and the required operator action, if any?>>

- A. <QQ 2166696(1480)><<RHR Pump 'B' trips. Attempt to manually start the pump per CPS 5065.03 (3A), RHR PUMP B AUTO TRIP.>>
- B. <QQ 2166696(1480)><<RHR Pump 'B' continues to operate at reduced flow. No action is required.>>
- C. <QQ 2166696(1480)><<RHR Pump 'B' continues to operate at reduced flow. Enter CPS 4006.01, Loss of Shutdown Cooling.>>
- D. <QQ 2166696(1480)><<RHR Pump 'B' trips. Enter CPS 4006.01, Loss of Shutdown Cooling.>>

Answer	<QQ 2166696(1419)><<D>>
--------	-------------------------

Answer Explanation

<QQ 2166696(1412)><<D is correct. Per CPS 4001.02C001 Automatic Isolation Checklist, a Group 3 isolation will occur when RPV level reaches 8.9 inches (Level 3). This will result in automatic closure of the following valves:

- 1E12-F053A RHR A To Feedwater S/D Cooling Rtrn Vlv
- 1E12-F053B RHR B To Feedwater S/D Cooling Rtrn Vlv
- 1E12-F008 Shutdown Cooling Outbd Suct Isol Vlv
- 1E12-F009 Shutdown Cooling Inbd Suct Isol Vlv
- 1E12-F023 RHR B Supp To Rx Head Spray Valve

Per 5065.03 (3A) RHR Pump B Auto Trip, RHR Pump 'B' will trip if the following a) & b) valve combination exists:

- a) 1E12-F004B, RHR B Suppr Pool Suction Valve not fully open.
- b) 1E12-F006B, RHR B Shutdown Cooling Suct Valve, or 1E12-F008, Shutdown Cooling Outbd Suct Isol Vlv, or 1E12-F009, Shutdown Cooling Inbd Suct Isol Vlv not fully open. either 1E12-F008 or F009 is not fully open.

CPS 4006.01, Loss of Shutdown Cooling is required to be entered since RHR is in Shutdown Cooling mode when the RHR pump tripped, resulting in a failure of the shutdown cooling mode in use.

Incorrect Responses:

A is incorrect but plausible. The RHR pump will trip as noted above, however; RHR Pump B manual restart is only required if it is necessary for safe shutdown of the plant per CPS 5065.03 (3A) Alarm Panel 5065 Annunciators - Row 3. This is plausible because numerous alarm response procedures direct restarting of a tripped pump.

B is incorrect but plausible. 1B21-F032B Feedwater Line B Containment Isolation Check Valve receives an isolation signal at Level 2 or High DW pressure. When actuated, flow through the 'B' FW line is restricted, causing RHR B SDC flow to decrease. Additionally, this casualty requires entry into CPS 4006.01, Loss of Shutdown Cooling per the symptoms.

C is incorrect but plausible. 1B21-F032B Feedwater Line B Containment Isolation Check Valve receives an isolation signal at Level 2 or High DW pressure. When actuated, flow through the 'B' FW line is restricted, causing RHR B SDC flow to decrease. The second part of this response is correct.>>

Question Information

Topic	<QQ 2166696(1400)><<The plant is performing a shutdown in preparation for a maintenance outage. RHR Pump 'B' is op>>				
User ID	<QQ 2166696(1404)><<CL-ILT-N19009>>			System ID	<QQ 2166696(1445)><<2166696>>
Status	<QQ 2166696(1405)><<Active>>	Point Value	<QQ 2166696(1441)><<1.00>>	Time (min)	<QQ 2166696(1408)><<0>>

Open or Closed Reference	<QQ 2166696(1409)><<CLOSED>>
Operator Type_Cognitive Level	<QQ 2166696(1415)><<RO-HIGH>>
Operator Discipline	<QQ 2166696(1413)><<LO-I>>
10CFR55 Content	<TB 479390(1305)><<CFR: 41.5 Facility operating characteristics during steady state and transient conditions, including coolant chemistry, causes and effects of temperature, pressure and reactivity changes, effects of load changes, and operating limitations and reasons for these operating characteristics.>>

References Provided	None
K/A Justification	Question meets the KA because the candidate must to predict the impact of lowering RPV water level on the RHR Shutdown Cooling system.
SRO-Only Justification	N/A
Additional Information	Question is high cog written at the analysis and comprehension level. The candidate must analyze the indications provided in the stem, and then determine impact and consequences of those conditions (2-RI).

NRC Exams Only			
Question Type	Bank (CL-ILT-N12011)	Difficulty	N/A
Technical Reference and Revision #	<ul style="list-style-type: none"> • CPS 4001.02C001 Rev. 16c • CPS 4006.01, Rev. 5d • CPS 5065.03 (3A) Rev. 28b 		
Training Objective	<p>203000.03 DESCRIBE the function, operation, interlocks, trips, physical locations, and power supplies of the following RESIDUAL HEAT REMOVAL System components.</p> <ul style="list-style-type: none"> .1 Suppression Pool Suction Strainer .2 RHR Pumps .3 RHR Heat Exchangers .4 B/C Water Leg Pump .5 Containment Spray Header and Nozzles .6 Suppression Pool Suction Valves F004A, F004B. .7 RH Shutdown Cooling Suction Valves F006A and F006B .8 Shutdown Cooling Inboard and Outboard Isolation Valves F009 and F008 .9 RH B Supply to Reactor Head Spray Valve F023 .10 RH C Full Flow Test Valve F021 .11 RH A (B) Full Flow Test Valves F024A and F024B .12 RH A (B) Containment Outboard Isolation Valves F027A and F027B .13 RH A(B) Containment Spray A(B) Shutoff Valves F028A and F028B .14 RH A(B) to Containment Pool Cooling Shutoff Valves F037A and F037B .15 LPCI From RH Shutoff Valves F042A, F042B, and F042C .16 LPCI From RH Testable Check Valves F041A, F041B, and F041C .17 RH Heat Exchanger Inlet Valves F047A and F047B .18 RH Heat Exchanger Outlet Valves F003A and F003B .19 RH B Radwaste First and Second Isolation Valves F049 and F040 .20 RH Heat Exchanger Bypass Valves F048A and F048B .21 RH to Feedwater Shutdown Cooling Return Valves F053A and F053B .22 RH Heat Exchanger First and Second Sample Valves F060A, F060B, F075A and F075B .23 RH Pump Minimum Flow Recirc Valves 		

	.24 F064A, F064B and F064C RH Heat Exchanger SSW Inlet and Outlet Valves F014A, F014B, F068A and F068B
	.25 RH Fuel Pool Cooling Assist Suction Valve F066
Previous NRC Exam Use	ILT 12-1 NRC

K/A Reference(s)

<CM 241096(1002)><<295021.AA1.02>>	Safety Function 4	Tier 1	Group 1	RO Imp: 3.5	SRO Imp: 3.5
<CM 241094(1001)><<Ability to operate and/or monitor the following as they apply to LOSS OF SHUTDOWN COOLING : (CFR: 41.7 / 45.6)>> <CM 241096(1001)><<RHR/shutdown cooling>>					

Learning Objective(s)

 <OB 1537828(1101)><<Q9 295021 AA1.02 (BH)>>
 User (Sys) ID N/A (<OB 1537828(1125)><<1537828>>)

Cross Reference Links

Table: <TB 775424(1301)><<TRAINING - QUESTIONS - Track Questions Modified in this Project (CL-OPS-EXAM-ILT)>>
<TB 776584(1305)><<Tracking link in project CL-OPS-EXAM-ILT to source question 2151143>>

Question 10	ID: 2166697	Points: 1.00
-------------	-------------	--------------

<QQ 2166697(1410)><<Plant conditions are as follows:

- The unit is in Mode 5.
- Core alterations and IFTS operations involving spent fuel are in progress.
- The Fuel Pool Cooling (FC) System is operating with the “A” pump and heat exchanger in service.
- An accident causes an unisolable leak to occur on the common outlet piping of the FC Surge Tanks, and Surge Tank water level is dropping very quickly.
- Attempts to raise surge tank level are unsuccessful.

(1) How is Spent Fuel Pool water level affected?
 (2) What action is required NEXT?>>

- A. <QQ 2166697(1480)><<(1) Continuously lower.
 (2) Suspend fuel movement.>>
- B. <QQ 2166697(1480)><<(1) Continuously lower.
 (2) Restore spent fuel pool cooling using Cycled Condensate (CY).>>
- C. <QQ 2166697(1480)><<(1) Lower slightly and stabilize.
 (2) Suspend fuel movement.>>
- D. <QQ 2166697(1480)><<(1) Lower slightly and stabilize.
 (2) Restore spent fuel pool cooling using Cycled Condensate (CY).>>

Answer	<QQ 2166697(1419)><<C>>
--------	-------------------------

Answer Explanation

<QQ 2166697(1412)><<C is correct:

A rapid drop in FC Surge Tank Level is an entry condition to CPS 4011.02 Spent Fuel Pool Abnormal Water Level Decrease. Per N-CL-OPS-233000 Fuel Pool Cooling and Cleanup System, water from the Spent Fuel Pool overflows the weirs into the FC Surge Tanks and is then pumped from the FC Surge Tanks back to the pool. Since makeup to the system is manual, a leak will drain the Surge tanks. As the Surge Tanks empty, no water will be available to be pumped to the Spent Fuel Pool, eliminating FC Pool Cooling capability. Spent Fuel Pool water level will lower until it reaches the bottom of the pool skimmers and then stabilize. As a result, operators must enter CPS 4011.02 and perform immediate operator actions, including suspending ANY fuel/core component lift operations after placing loads in a safe condition.

Incorrect Responses:

A is incorrect but plausible because it is partially correct and because in most plant systems, a leak would cause level to lower continuously. However, the design of the Spent Fuel Pool will only allow pool level to lower to and stabilize at the top of the weirs. The second part of the response is correct.

B is incorrect but plausible. In most plant systems, a leak would cause level to lower continuously. However, the design of the Spent Fuel Pool will only allow pool level to lower to and stabilize at the top of the weirs. The second part of the response is also incorrect. Restoring spent fuel pool cooling using CY is required as a subsequent action per CPS 4011.02, but is not an immediate operator action.

D is incorrect but plausible because it is partially correct. The first part of the response is correct. The second part is incorrect. Restoring spent fuel pool cooling using CY is required as a subsequent action per CPS 4011.02, but is not an immediate operator action.>>

Question Information

Topic	<QQ 2166697(1400)><<Plant conditions are as follows: The unit is in Mode 5. Core alterations and IFTS operations invo>>				
User ID	<QQ 2166697(1404)><<CL-ILT-N19010>>		System ID	<QQ 2166697(1445)>><<2166697>>	
Status	<QQ 2166697(1405)>><<Active>>	Point Value	<QQ 2166697(1441)>><<1.00>>	Time (min)	<QQ 2166697(1408)>><<0>>

Open or Closed Reference	<QQ 2166697(1409)><<CLOSED>>
Operator Type_Cognitive Level	<QQ 2166697(1415)><<RO-HIGH>>
Operator Discipline	<QQ 2166697(1413)><<LO-I>>
10CFR55 Content	<TB 479392(1305)><<CFR: 41.7 Design, components, and functions of control and safety systems, including instrumentation, signals, interlocks, failure modes, and automatic and manual features.>>

References Provided	None
K/A Justification	Question meets the KA because the candidate must determine the effect a refuel accident will have on spent fuel pool level and recognize actions to be taken.
SRO-Only Justification	N/A
Additional Information	Question is high cog written at the analysis and application level. The candidate must analyze the parameters in the stem and then determine plant response based on that analysis (3-SPK).

NRC Exams Only			
Question Type	Bank (CL-ILT-635456)	Difficulty	N/A

Technical Reference and Revision #	<ul style="list-style-type: none"> • CPS 4011.02 Rev. 7d • N-CL-OPS-233000 Rev. 11
Training Objective	233000.09 DISCUSS the effect: 1. A total loss or malfunction of the Fuel Pool Cooling & Cleanup System has on the plant. 2. A total loss or malfunction of various plant systems has on the Fuel Pool Cooling & Cleanup System.
Previous NRC Exam Use	None

K/A Reference(s)

<CM 241164(1002)><<295023.AA2.02>>	Safety Function 8	Tier 1	Group 1	RO Imp: 3.4	SRO Imp: 3.7
<CM 241162(1001)><<Ability to determine and/or interpret the following as they apply to REFUELING ACCIDENTS : (CFR: 41.10 / 43.5 / 45.13)>> <CM 241164(1001)><<Fuel pool level>>					

Learning Objective(s)

 <OB 1537829(1101)><<Q10 295023 AA2.02 (BH)>>
 User (Sys) ID N/A (<OB 1537829(1125)><<1537829>>)

Cross Reference Links

Table: <TB 775424(1301)><<TRAINING - QUESTIONS - Track Questions Modified in this Project (CL-OPS-EXAM-ILT)>>
<TB 776585(1305)><<Tracking link in project CL-OPS-EXAM-ILT to source question 2151171>>

Question 11	ID: 2151247	Points: 1.00
-------------	-------------	--------------

<QQ 2151247(1410)><<The plant is operating at rated thermal power (RTP).

THEN, a Loss of Coolant Accident (LOCA) occurred.

- High Pressure Core Spray (HPCS) automatically initiated on Drywell pressure.
- RPV water level has reached Level 8.

When RPV water level lowers below level 8, which of the following actions, if any, must the operator perform to manually re-establish HPCS injection to the RPV?>>

- A. <QQ 2151247(1480)><<Open HPCS To CNMT Outbd IsIn Valve (1E22-F004).>>
- B. <QQ 2151247(1480)><<Arm and depress the HPCS Manual Initiation pushbutton.>>
- C. <QQ 2151247(1480)><<Depress the HPCS High Water Level Seal In Reset pushbutton.>>
- D. <QQ 2151247(1480)><<No action is required. HPCS will re-initiate upon RPV level lowering to Level 3.>>

Answer	<QQ 2151247(1419)><<C>>
--------	-------------------------

Answer Explanation

<QQ 2151247(1412)><<C is correct.

Per CPS 3309.01, 1E22-F004, HPCS to CNMT Outboard Isolation Valve opens automatically on a HPCS initiation signal and closes on high Reactor water Level 8. High Reactor water Level 8 closure seals in unless either of the following occurs:

- Level drops to Level 2. The valve will cycle between Level 8 and Level 2.
- With level less than Level 8 the High Water Level Reset pushbutton is depressed, and the control switch is operated to open F004. (This assumes that an initiation signal is not present. If it is present, the F004 will re-open as soon as the Level 8 Reset pushbutton is depressed.)

Incorrect Responses:

A is incorrect but plausible. 1E22-F004 does need to be opened to re-inject HPCS, but CPS 3309.01, section 8.1.3 specifies that to open 1E22-F004 that has closed on Level 8, the RX WTR LEVEL HI SEAL IN RESET push-button must be depressed (when > Level 2).

B is incorrect but plausible. Using the HPCS manual initiation pushbutton will result in HPCS initiating as described above, but will not cause 1E22-F004 to reopen if a level 8 signal is locked in.

D is incorrect but plausible. HPCS will re-initiate automatically when level reaches Level 2, not Level 3.>>

Question Information

Topic	<QQ 2151247(1400)><<The plant is operating at rated thermal power (RTP). THEN, a Loss of Coolant Accident (LOCA) occ>>				
User ID	<QQ 2151247(1404)><<CL-ILT-N19011>>		System ID	<QQ 2151247(1445)><<2151247>>	
Status	<QQ 2151247(1405)><<Active>>	Point Value	<QQ 2151247(1441)><<1.00>>	Time (min)	<QQ 2151247(1408)><<0>>

Open or Closed Reference	<QQ 2151247(1409)><<CLOSED>>
Operator Type_Cognitive Level	<QQ 2151247(1415)><<RO-MEMORY>>
Operator Discipline	<QQ 2151247(1413)><<LO-I>>
10CFR55 Content	<TB 479392(1305)><<CFR: 41.7 Design, components, and functions of control and safety systems, including instrumentation, signals, interlocks, failure modes, and automatic and manual features.>>

References Provided	None
K/A Justification	Question meets the KA because the candidate must demonstrate knowledge of the functions of various HPCS components and how to operate them following a high drywell pressure transient.
SRO-Only Justification	N/A
Additional Information	Question is low cog written at the memory level. The candidate must recall facts pertaining to and contained in a procedure (1-F).

NRC Exams Only			
Question Type	Bank (CL-ILT-A11008)	Difficulty	N/A
Technical Reference and Revision #	<ul style="list-style-type: none"> CPS 3309.01 Rev. 18a 		

Training Objective	209002.03 DESCRIBE the function, operation, interlocks, trips, physical location, and power supplies of the following HIGH PRESSURE CORE SPRAY System components. .1 RCIC Storage Tank .2 Suction Strainer .3 Pump Suction Valves .4 HPCS Pump .5 Water Leg Pump .6 Minimum Flow Valve .7 Test Return Valves .8 HPCS to Cntmt Otbd Isol Valve .9 Testable Check Valve .10 Reactor Vessel Spray Sparger .11 Relief Valves .12 HPCS HVAC System
Previous NRC Exam Use	None

K/A Reference(s)

<CM 241914(1002)><<B2.1.28>>	Safety Function 8	Tier 3	Group	RO Imp: 4.1	SRO Imp: 4.1
<CM 241914(1001)><<Knowledge of the purpose and function of major system components and controls. (CFR: 41.7)>>					
<CM 246592(1002)><<GS.295024>>	Safety Function 5	Tier 1	Group 1	RO Imp:	SRO Imp:
<CM 246592(1001)><<High Drywell Pressure>>					

Learning Objective(s)

 <OB 1537830(1101)><<Q11 295024 2.1.28 (BL)>>
 User (Sys) ID N/A (<OB 1537830(1125)><<1537830>>)

Cross Reference Links

None

Question 12	ID: 2151252	Points: 1.00
-------------	-------------	--------------

<QQ 2151252(1410)><<Due to a Feedwater Level Control System malfunction, the plant has scrammed after several months at rated thermal power with the following conditions:

- Reactor water level is being maintained Level 3 - Level 8 using Feedwater.
- Reactor pressure is being maintained at 917 psig using bypass valves.
- 1A and 1C Circulating Water (CW) pumps are running due to repairs being performed on 1B CW pump.

THEN, an electrical fault causes 6.9KV bus 1A to de-energize.

If NO operator action is taken, how will RPV pressure respond over the next several minutes?>>

- A. <QQ 2151252(1480)><<Remain steady at 917 psig.>>
- B. <QQ 2151252(1480)><<Lower to a value below 917 psig.>>
- C. <QQ 2151252(1480)><<Rise to a peak value of 1033 psig.>>
- D. <QQ 2151252(1480)><<Rise to a peak value of 1103 psig.>>

Answer	<QQ 2151252(1419)><<D>>
--------	-------------------------

Answer Explanation

<QQ 2151252(1412)><<D is correct.

Given the conditions in the stem, the decay heat will cause reactor pressure to rise. CPS 4100.01 Reactor Scram section 2.2. states that turbine bypass valves/SRVs open to control RPV pressure. With no CW pumps running, bypass valves will not have a heat sink, therefore, SRVs will open to control pressure. Per CPS 9442.01A SRV Reactor Pressure B21-N068A Channel Calibration, the lowest Safety Relief Valve (SRV) setpoint is 1103 psig. Reactor pressure will rise until it reaches that point, then it will lower once the SRV opens.

Incorrect Responses:

A is incorrect but plausible. Following extended operation at power, decay heat causes reactor temperature and pressure to rise. This answer would be correct if the main condenser were available.

B is incorrect but plausible. Reactor pressure would eventually lower as decay heat is removed if there were a heat sink available; however, conditions given indicate a loss of the main condenser. The resultant pressure rise due to decay heat will continue until an SRV lifts.

C is incorrect but plausible. Reactor pressure will rise due to decay heat and a loss of the main condenser, but the first SRV will lift at 1103 psig. The pressure given in this distractor is the Low-Low Set (LLS) setpoint of 1033 per CPS 5067.06 ALARM PANEL 5067 ANNUNCIATORS - ROW 1 (6C) LOW-

LOW SETPT DIV 1 SEALED IN, but conditions for LLS have not been met.>>

Question Information

Topic	<QQ 2151252(1400)><<Due to a Feedwater Level Control System malfunction, the plant has scrambled after several months at>>				
User ID	<QQ 2151252(1404)><<CL-ILT-N19012>>		System ID	<QQ 2151252(1445)><<2151252>>	
Status	<QQ 2151252(1405)><<Active>>	Point Value	<QQ 2151252(1441)><<1.00>>	Time (min)	<QQ 2151252(1408)><<0>>

Open or Closed Reference	<QQ 2151252(1409)><<CLOSED>>
Operator Type_Cognitive Level	<QQ 2151252(1415)><<RO-HIGH>>
Operator Discipline	<QQ 2151252(1413)><<LO-I>>
10CFR55 Content	<TB 479392(1305)><<CFR: 41.7 Design, components, and functions of control and safety systems, including instrumentation, signals, interlocks, failure modes, and automatic and manual features.>>

References Provided	None
K/A Justification	Question meets the KA because the candidate must interpret the conditions given in the stem and recognize the operational implication of decay heat generation on reactor pressure following a loss of circulating water.
SRO-Only Justification	N/A
Additional Information	Question is high cog written at the analysis/comprehension level. The candidate must analyze the plant conditions provided in the stem and determine the plant response based on that analysis (3-SPK).

NRC Exams Only			
Question Type	New	Difficulty	N/A
Technical Reference and Revision #	<ul style="list-style-type: none"> • CPS 5067.06 (6C) Rev. 31 • CPS 4100.01 Rev. 23f • CPS 9442.01A Rev. 0b 		

Training Objective	400006.09DISCUSS the effect: 1. A total loss or malfunction of the CIRCULATING WATER System has on the plant. 2. A total loss or malfunction of various plant systems has on the CIRCULATING WATER System.
Previous NRC Exam Use	None

K/A Reference(s)

<CM 241276(1002)><<295025.EK1.04>>	Safety Function 3	Tier 1	Group 1	RO Imp: 3.6	SRO Imp: 3.9
<CM 241272(1001)><<Knowledge of the operational implications of the following concepts as they apply to HIGH REACTOR PRESSURE : (CFR: 41.8 to 41.10)>> <CM 241276(1001)><<Decay heat generation>>					

Learning Objective(s)

 <OB 1537831(1101)><<Q12 295025 EK1.04 (NH)>>
 User (Sys) ID N/A (<OB 1537831(1125)><<1537831>>)

Cross Reference Links

None

Question 13	ID: 2166917	Points: 1.00
-------------	-------------	--------------

<QQ 2166917(1410)><<The shift has entered CPS 4009.01, Inadvertent Opening Safety Relief Valve. The Critical Safety Function (CSF) display has just changed to the SPDS indication screen show below.



(1) Average Suppression Pool Temperature ____.
 (2) What procedure is required to be entered next?>>

- A. <QQ 2166917(1480)><<(1) is low confidence data on SPDS.
 (2) 4100.01, Reactor Scram.>>
- B. <QQ 2166917(1480)><<(1) is low confidence data on SPDS.
 (2) EOP-6, Primary Containment Control.>>
- C. <QQ 2166917(1480)><<(1) has exceeded an SPDS alarm setpoint.
 (2) 4100.01, Reactor Scram.>>
- D. <QQ 2166917(1480)><<(1) has exceeded an SPDS alarm setpoint.
 (2) EOP-6, Primary Containment Control.>>

Answer	<QQ 2166917(1419)><<D>>
--------	-------------------------

Answer Explanation

<QQ 2166917(1412)><<D is correct.

Per CPS 5004.03 (3F), a suppression pool temperature of 95°F is an EOP-6 entry and exceeds the SPDS alarm setpoint, causing the CSF box on the SPDS screen to shift to red.

Incorrect Responses:

A is incorrect but plausible, because low confidence data will cause the SPDS box to shift color, but to white. Additionally, a reactor scram is required for high suppression pool temperature at 108.7°F, but the stem does not indicate that temperature has risen that high.

B is incorrect but plausible, because low confidence data will cause the SPDS box to shift color, but to white. The second part of the response is correct.

C is incorrect but plausible. The first part of the response is correct; however, a reactor scram is required for high suppression pool temperature at 108.7°F, but the stem does not indicate that temperature has risen that high. The next procedure required to be entered is EOP-6.>>

Question Information

Topic	<QQ 2166917(1400)><<The shift has entered CPS 4009.01, Inadvertent Opening Safety Relief Valve. The Critical Safety >>				
User ID	<QQ 2166917(1404)><<CL-ILT-N19013>>		System ID	<QQ 2166917(1445)><<2166917>>	
Status	<QQ 2166917(1405)><<Active>>	Point Value	<QQ 2166917(1441)><<1.00>>	Time (min)	<QQ 2166917(1408)><<0>>

Open or Closed Reference	<QQ 2166917(1409)><<CLOSED>>
Operator Type_Cognitive Level	<QQ 2166917(1415)><<RO-MEMORY>>
Operator Discipline	<QQ 2166917(1413)><<LO-I>>
10CFR55 Content	<TB 479392(1305)><<CFR: 41.7 Design, components, and functions of control and safety systems, including instrumentation, signals, interlocks, failure modes, and automatic and manual features.>>

References Provided	None
K/A Justification	Question meets the KA because the candidate must determine how a high temperature in the suppression pool will affect SPDS.
SRO-Only Justification	N/A
Additional Information	Question is low cog written at the memory level. The candidate must recall facts pertaining to and contained in a procedure (1-F).

NRC Exams Only			
Question Type	New	Difficulty	N/A
Technical Reference and Revision #	<ul style="list-style-type: none"> CPS 4100.01, Rev. 23f CPS 5004.03 (3F) Rev. 28b 		
Training Objective	700003.06 Given an PPC system Annunciator, DESCRIBE: <ol style="list-style-type: none"> The condition causing the annunciator Any automatic actions Any operational implications 		
Previous NRC Exam Use	None		

K/A Reference(s)

<CM 241317(1002)><<295026.EK2.04>>	Safety Function 5	Tier 1	Group 1	RO Imp: 2.5	SRO Imp: 2.8
<CM 241313(1001)><<Knowledge of the interrelations between SUPPRESSION POOL HIGH WATER TEMPERATURE and the following: (CFR: 41.7 / 45.8)>> <CM 241317(1001)><<SPDS/ERIS/CRIDS/GDS: Plant-Specific>>					

Learning Objective(s)

 <OB 1537832(1101)><<Q13 295026 EK2.04 (BL)>>
 User (Sys) ID N/A (<OB 1537832(1125)><<1537832>>)

Cross Reference Links

Table: <TB 775424(1301)><<TRAINING - QUESTIONS - Track Questions Modified in this Project (CL-OPS-EXAM-ILT)>>
<TB 776684(1305)><<Tracking link in project CL-OPS-EXAM-ILT to source question 2151265>>

Question 14	ID: 2151383	Points: 1.00
-------------	-------------	--------------

<QQ 2151383(1410)><<A transient has occurred resulting in the following conditions:

Parameter	Value	Trend
Drywell Temperature	205°F	Rising
Containment Temperature	190°F	Rising
Containment Pressure	3.0 psig	Rising
Reactor Pressure	200 psig	Lowering
Suppression Pool Temperature	122°F	Rising
Suppression Pool Level	20 feet	Stable

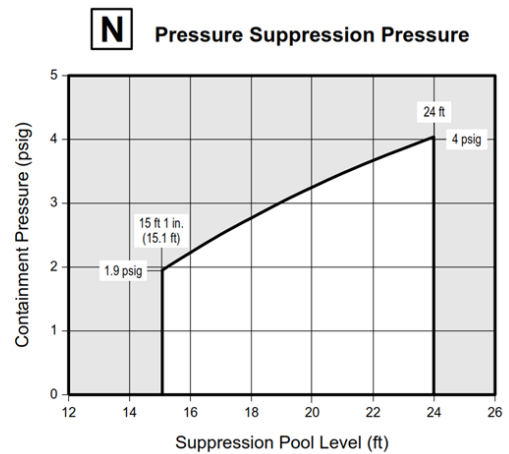
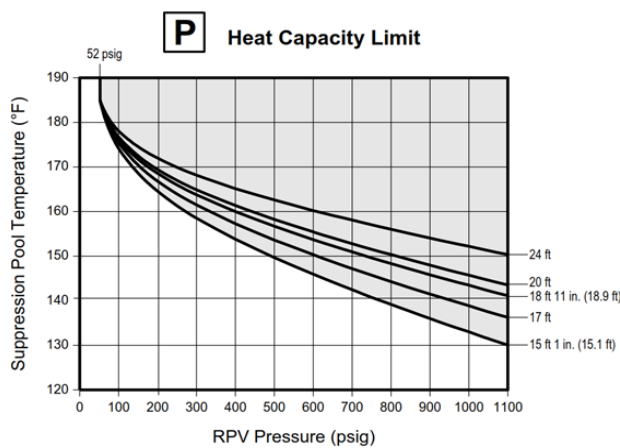

Why must a blowdown be performed under these conditions?>>

- A. <QQ 2151383(1480)><<Drywell failure is imminent.>>
- B. <QQ 2151383(1480)><<the operability of equipment in the containment may be jeopardized.>>
- C. <QQ 2151383(1480)><<the suppression pool may NOT absorb the energy from a loss of coolant accident.>>
- D. <QQ 2151383(1480)><<To limit energy release into containment before RPV pressure drops to decay heat removal pressure.>>

Answer	<QQ 2151383(1419)><>
--------	-------------------------

Answer Explanation

<QQ 2151383(1412)><<B is correct.

Per the EOP Tech Bases for EOP-6 Primary Containment Control, containment temperature above 122°F

(the Technical Specification LCO limit) is a symptom of events which may jeopardize primary containment integrity and the operability of equipment in the containment. A blowdown is directed by EOP-6 if containment temperature cannot be maintained below 185°F.

Incorrect Responses:

A is incorrect but plausible. Elevated DW temperature is provided in the stem. If drywell temperature cannot be restored and held below 330°F, a blowdown is performed to limit further release of energy into the drywell, thus minimizing the drywell heatup. The specified temperature is the lower of the maximum temperature at which ADS is qualified (340°F) and the drywell design temperature (330°F).

C is incorrect but plausible. This is the bases for the Heat Capacity Limit, which is based on Suppression Pool Temperature, RPV Pressure, and SP Level. Elevated temperature and level in the suppression pool are given in the stem, but they are not high enough to warrant a blowdown.

D is incorrect but plausible. This is the basis for the Pressure Suppression Pressure Limit, which is based on Suppression Pool Level and Containment Pressure. Elevated pressure in the containment and elevated level in the Suppression Pool are given in the stem, but they are not high enough to warrant a blowdown.>>

Question Information

Topic	<QQ 2151383(1400)><<A transient has occurred resulting in the following conditions: ParameterValueTrendDrywell Tem>>				
User ID	<QQ 2151383(1404)><<CL-ILT-N19014>>			System ID	<QQ 2151383(1445)><<2151383>>
Status	<QQ 2151383(1405)><<Active>>	Point Value	<QQ 2151383(1441)><<1.00>>	Time (min)	<QQ 2151383(1408)><<0>>

Open or Closed Reference	<QQ 2151383(1409)><<CLOSED>>
Operator Type_Cognitive Level	<QQ 2151383(1415)><<RO-HIGH>>
Operator Discipline	<QQ 2151383(1413)><<LO-I>>
10CFR55 Content	<TB 479395(1305)><<CFR: 41.10 Administrative, normal, abnormal, and emergency operating procedures for the facility.>>

References Provided	None
K/A Justification	Question meets the KA because the candidate must evaluate the conditions in the stem and recognize that an emergency depressurization is required due to high containment temperature.
License Level Justification	Question is RO level because it evaluates the candidate's ability to determine why emergency depressurization is required for high containment temperature. The reference for this question is the

	EOP Tech Bases, which RO's are responsible for knowing. Also linked to RO tasks 430301.08, Carry out Mitigating Strategies of 4303.01 with respect to Containment Integrity and 100509.16, Demonstrate knowledge of symptom based EOP mitigation strategies.
Additional Information	Question is high cog, written at the analysis and comprehension level. Candidate must evaluate a number of parameters provided in the stem and then determine the bases for the action that is required to be performed (3-SPK).

NRC Exams Only			
Question Type	Bank (CL-ILT-N15003)	Difficulty	N/A
Technical Reference and Revision #	<ul style="list-style-type: none"> EOP-TB Rev. 7 CPS 4402.01 Rev. 30 		
Training Objective	223001.11 EVALUATE given key PRIMARY CONTAINMENT System parameters, if needed DETERMINE a course of action to correct or mitigate the following abnormal condition(s): .7 High containment temperature		
Previous NRC Exam Use	ILT 15-1 NRC		

K/A Reference(s)

<CM 241346(1002)><<295027.EK3.01>>	Safety Function 5	Tier 1	Group 1	RO Imp: 3.7	SRO Imp: 3.8
<CM 241345(1001)><<Knowledge of the reasons for the following responses as they apply to HIGH CONTAINMENT TEMPERATURE (MARK III CONTAINMENT ONLY) : (CFR: 41.5 / 45.6)>> <CM 241346(1001)><<Emergency depressurization: Mark-III>>					

Learning Objective(s)

 <OB 1537833(1101)><<Q14 295027 EK3.01 (BH)>>
 User (Sys) ID N/A (<OB 1537833(1125)><<1537833>>)

Cross Reference Links

None

Question 15	ID: 2152102	Points: 1.00
-------------	-------------	--------------

<QQ 2152102(1410)><<The plant was operating at rated thermal power.

THEN, an event occurred causing Suppression Pool (SP) level to lower.

Current conditions:

- Reactor Core Isolation Cooling (RCIC) suction is lined up to the SP.
- RCIC is providing RPV level and pressure control.
- SP level is currently 16 feet 3 inches and lowering at 2 inches/minute.
- All required EOP actions have been taken up to this point.

What is the MAXIMUM time (in minutes) before continued operation of the RCIC pump is threatened (possible equipment damage)?>>

- A. <QQ 2152102(1480)><<7>>
- B. <QQ 2152102(1480)><<19>>
- C. <QQ 2152102(1480)><<31.5>>
- D. <QQ 2152102(1480)><<49.5>>

Answer	<QQ 2152102(1419)><<C>>
--------	-------------------------

Answer Explanation

<QQ 2152102(1412)><<C is correct.

Per the CPS Emergency Operating Procedure Technical Bases (EOP-TB), NPSH/Vortex Limits:

- NPSH and vortex restrictions for each system are listed in Detail Z. A suppression pool level of 11 ft. bounds both NPSH and vortex limits for HPCS, LPCS, and RHR. The RCIC limits are bounded by a combination of suppression pool level, suppression pool temperature, and pump flow.
 - Minimum SP level - 11 ft.
 - Minimum SP temperature - 197 °F
 - Maximum RCIC flow - 700 gpm
- Although the caution does not expressly prohibit use of the systems beyond NPSH and vortex limits, operation outside the Detail Z restrictions should be considered only if the risk of equipment damage is warranted by the nature of the event.

16' 3" - 11' = 5' 3"; 5' 3" / 2" per min = 31.5 min.

Incorrect responses:

A is incorrect but plausible. This response would be correct if the RCIC NPSH/Vortex limit was 15' 1". 16' 3" - 15' 1" = 1' 2"; 1' 2" / 2" per min = 7 min. Per CPS 4402.01 EOP-6 Primary Containment Control, 15' 1" is the lowest level at which the upper pools should be dumped.

B is incorrect but plausible. This response would be correct if the RCIC NPSH/Vortex limit was 13' 1". 16' 3" - 13' 1" = 3' 2"; 1' 2" / 2" per min = 19 min. Per EOP-6, 13' 1" is the lowest level at which the mixing compressors should be stopped.

D is incorrect but plausible. This response would be correct if the RCIC NPSH/Vortex limit was 8'. 16' 3" - 8' = 8' 3"; 8' 3" / 2" per min = 49.5 min. Per CPS 4401.01 EOP-1 RPV Control, 8' is the SP level below which Safety Relief Valves (SRVs) may no longer be used to control RPV pressure.>>

Question Information

Topic	<QQ 2152102(1400)><<The plant was operating at rated thermal power. THEN, an event occurred causing Suppression Pool>>				
User ID	<QQ 2152102(1404)><<CL-ILT-N19015>>		System ID	<QQ 2152102(1445)><<2152102>>	
Status	<QQ 2152102(1405)><<Active>>	Point Value	<QQ 2152102(1441)><<1.00>>	Time (min)	<QQ 2152102(1408)><<0>>

Open or Closed Reference	<QQ 2152102(1409)><<CLOSED>>
Operator Type_Cognitive Level	<QQ 2152102(1415)><<RO-HIGH>>
Operator Discipline	<QQ 2152102(1413)><<LO-I>>
10CFR55 Content	<TB 479395(1305)><<CFR: 41.10 Administrative, normal, abnormal, and emergency operating procedures for the facility.>>

References Provided	None
K/A Justification	Question meets the KA because the candidate must demonstrate the ability to monitor a lowering SP water level and determine when there will be consequences to the RCIC pump to answer the question.
SRO-Only Justification	N/A
Additional Information	Question is high cog written at the comprehension level. The candidate must recognize the relationship between SP water level and the RCIC pump and then determine when there will be consequences to the RCIC pump (2-RI).

NRC Exams Only			
Question Type	New	Difficulty	N/A

Technical Reference and Revision #	<ul style="list-style-type: none"> • CPS 4401.01Rev. 30 • CPS 4402.01 Rev. 30 • EOP-TB Rev. 7
Training Objective	217000.10 EXPLAIN the reasons for given REACTOR CORE ISOLATION COOLING (RI) System operating limits and precautions.
Previous NRC Exam Use	None

K/A Reference(s)

<CM 241408(1002)><<295030.EA1.02>>	Safety Function 5	Tier 1	Group 1	RO Imp: 3.4	SRO Imp: 3.5
<CM 241406(1001)><<Ability to operate and/or monitor the following as they apply to LOW SUPPRESSION POOL WATER LEVEL: (CFR: 41.7 / 45.6)>> <CM 241408(1001)><<RCIC: Plant-Specific>>					

Learning Objective(s)

 <OB 1537834(1101)><<Q15 295030 EA1.02 (NH)>>
 User (Sys) ID N/A (<OB 1537834(1125)><<1537834>>)

Cross Reference Links

None

Question 16	ID: 2157063	Points: 1.00
-------------	-------------	--------------

<QQ 2157063(1410)><<The plant is operating at rated thermal power.

THEN, both Turbine Driven Reactor Feed Pumps (TDRFP) trip.

The Reactor Protection System has failed to actuate.

As Reactor Pressure Vessel (RPV) level lowers, assuming no operator action is taken, reactor power will lower because at Level ____ (1)____, the RR pumps ____ (2)____.>>

- A. <QQ 2157063(1480)><<(1) 4
(2) shift to slow speed>>
- B. <QQ 2157063(1480)><<(1) 4
(2) trip to OFF>>
- C. <QQ 2157063(1480)><<(1) 2
(2) shift to slow speed>>
- D. <QQ 2157063(1480)><<(1) 2
(2) trip to OFF>>

Answer	<QQ 2157063(1419)><<D>>
--------	-------------------------

Answer Explanation

<QQ 2157063(1412)><<D is correct.

Per CPS 4008.01, RPV Level 2 will cause a RR pump trip. This is due to an Anticipated Transient Without Scram (ATWS); the Alternate Rod Insertion (ARI) inserts a RR pump trip at Level 2 or RPV pressure of 1127. This inserts negative reactivity to lower power in the reactor core.

Incorrect Responses:

A is incorrect but plausible. A TDRFP tripped with RPV level < Level 4 would cause a Flow Control Valve runback to reduce power, but not shift the RR pumps to slow speed.

B is incorrect but plausible. A TDRFP tripped with RPV level < Level 4 would cause a Flow Control Valve runback to reduce power, but not trip the RR pumps off.

C is incorrect but plausible. RR pumps shift to slow speed at Level 3. At Level 2, RR pumps trip to off.>>

Question Information

Topic	<QQ 2157063(1400)><<The plant is operating at rated thermal power. THEN, both Turbine Driven Reactor Feed Pumps (TD)>>				
User ID	<QQ 2157063(1404)><<CL-ILT-N19016>>		System ID	<QQ 2157063(1445)><<2157063>>	
Status	<QQ 2157063(1405)><<Active>>	Point Value	<QQ 2157063(1441)><<1.00>>	Time (min)	<QQ 2157063(1408)><<0>>

Open or Closed Reference	<QQ 2157063(1409)><<CLOSED>>
Operator Type_Cognitive Level	<QQ 2157063(1415)><<RO-MEMORY>>
Operator Discipline	<QQ 2157063(1413)><<LO-I>>

References Provided	None
K/A Justification	Question meets the KA because the candidate must determine the plant response to lower reactor power based on the loss of feedwater and resultant low reactor water level.
SRO-Only Justification	N/A
Additional Information	Question is low cog written at the memory level. Candidate must recall facts and information contained in a procedure (1-F).

NRC Exams Only			
Question Type	New	Difficulty	N/A
Technical Reference and Revision #	<ul style="list-style-type: none"> CPS 4008.01 Rev. 20e 		
Training Objective	202001.03 DESCRIBE the function, operation, interlocks, trips, and power supplies of the following Reactor Recirculation System components. <ol style="list-style-type: none"> .1 Reactor Recirculation Pumps .2 RR Pump Mechanical Seal .3 Recirculation Flow Control Valves .4 Recirculation Pump Suction and Discharge Valves .5 Jet Pumps .6 Hydraulic Power Units .7 HPU Servo Control Valve .8 HPU Pilot Operated Isolation Valve 		

	.9 HPU Pilot Operated Lockout Valve .10 HPU Shuttle Valve .11 HPU Solenoid Operated Isolation Valves .12 HPU Subloop Discharge Bypass Valve .13 Low Frequency Motor Generator (LFMG) Sets .14 Piping .15 Flow Diverters .16 Recirculation Flow Instrumentation
Previous NRC Exam Use	None

K/A Reference(s)

<CM 241457(1002)><<295031.EA2.02>>	Safety Function 2	Tier 1	Group 1	RO Imp: 4.0	SRO Imp: 4.2*
<CM 241455(1001)><<Ability to determine and/or interpret the following as they apply to REACTOR LOW WATER LEVEL : (CFR: 41.10 / 43.5 / 45.13)>> <CM 241457(1001)><<Reactor power>>					

Learning Objective(s)

 <OB 1537835(1101)><<Q16 295031 EA2.02 (NL)>>
 User (Sys) ID N/A (<OB 1537835(1125)><<1537835>>)

Cross Reference Links

Table: <TB 775424(1301)><<TRAINING - QUESTIONS - Track Questions Modified in this Project (CL-OPS-EXAM-ILT)>>
<TB 776764(1305)><<Tracking link in project CL-OPS-EXAM-ILT to source question 2157063>>

Question 17	ID: 2157125	Points: 1.00
-------------	-------------	--------------

<QQ 2157125(1410)><<The plant was operating at rated thermal power (RTP).

THEN, a reactor SCRAM occurs.

- Shutdown criteria is NOT met.

At 1300, Standby Liquid Control (SLC) was initiated using CPS 4411.01H001 SLC Initiation. The following indications were observed:

- SLC DISCH TO RPV SQUIB A light is NOT illuminated.
- SLC DISCH TO RPV SQUIB B light is NOT illuminated.
- SLC Suction Valve 1C41-F001A opened.
- SLC Suction Valve 1C41-F001B opened.
- SLC Discharge pressure is 1100 psig.

The earliest time that full boron concentration is considered to be injected is between ____ (1) ____.

SLC injection under these conditions will ____ (1) ____.>>

- A. <QQ 2157125(1480)><<(1) 1340 - 1345
(2) ensure iodine will be retained in the suppression pool water>>
- B. <QQ 2157125(1480)><<(1) 1420 - 1425
(2) ensure iodine will be retained in the suppression pool water>>
- C. <QQ 2157125(1480)><<(1) 1340 - 1345
(2) shut down and maintain the reactor shutdown under all conditions>>
- D. <QQ 2157125(1480)><<(1) 1420 - 1425
(2) shut down and maintain the reactor shutdown under all conditions>>

Answer	<QQ 2157125(1419)><<C>>
--------	-------------------------

Answer Explanation

QQ 2157125(1412)><<C is correct.

Per N-CL-OPS-211000 Standby Liquid Control (SC) System and CPS 4411.10 SLC Operations:

Full boron concentration (has been) injected while maintaining adequate NPSH for the SLC pumps, when:

- SLC tank level drops to 0 gal OR
- Both SLC pumps have run for 40 min OR
- One SLC pump has run for 80 min.

Per the CPS USAR Section 9.3.5 Standby Liquid Control (SLC) System

:

- SLC is initiated if the operator believes the reactor cannot be shutdown or kept shut down with the control rods, OR
- following a LOCA involving fuel damage for pH control of the suppression pool.

Based on the conditions presented in the stem, an ATWS condition is presented with two (2) SLC pumps injecting. Therefore, the 40 minutes run time for two (2) pumps to inject full boron concentration is complete at ~1340. Additionally, SLC injection under these conditions will shutdown and maintain the reactor shutdown under all conditions.

Incorrect Responses:

A is incorrect but plausible. The first part of this response is correct. The second part of this response is plausible because injecting boron via the SLC system in the event of a LOCA involving fuel damage will control suppression pool pH. However, the conditions presented in the stem are not indicative of a LOCA involving fuel damage.

B is incorrect but plausible. This response is plausible and would be correct if stem conditions were indicative of:

- one (1) SLC pump injecting, AND
- a LOCA involving fuel damage was in progress.

D is incorrect but plausible. The first part of this response is plausible because the time required to achieve full boron concentration is dependent on the number of injecting SLC pumps. One (1) SLC pump must run for approximately 80 minutes to achieve full boron concentration. However, the conditions in the stem indicate both pumps are injecting. The second part of this response is correct.>>

Question Information

Topic	<QQ 2157125(1400)><<The plant was operating at rated thermal power (RTP). THEN, a reactor SCRAM occurs. Shutdown cr>>				
User ID	<QQ 2157125(1404)><<CL-ILT-N19017>>			System ID	<QQ 2157125(1445)><<2157125>>
Status	<QQ 2157125(1405)><<Active>>	Point Value	<QQ 2157125(1441)><<1.00>>	Time (min)	<QQ 2157125(1408)><<0>>

Open or Closed Reference	<QQ 2157125(1409)><<CLOSED>>
Operator Type_Cognitive Level	<QQ 2157125(1415)><<RO-HIGH>>
Operator Discipline	<QQ 2157125(1413)><<LO-I>>
10CFR55 Content	<TB 479391(1305)><<CFR: 41.6 Design, components, and functions of reactivity control mechanisms and instrumentation.>>

References Provided	None
K/A Justification	Question meets the KA because the candidate must demonstrate knowledge of the reasons for SLC injection as it applies to an ATWS to answer the question.
SRO-Only Justification	N/A
Additional Information	Question is high cog, written at the comprehension level. The candidate must recognize the similarities and differences of boron injection based on plant conditions. (2-RW).

NRC Exams Only			
Question Type	New	Difficulty	N/A
Technical Reference and Revision #	<ul style="list-style-type: none"> CPS/USAR (9.3-12) Rev. 20N-CL-OPS-211000 Rev. 7 CPS 4411.10 Rev. 6c 		
Training Objective	211000.01 STATE the purpose(s) of the STANDBY LIQUID CONTROL System including applicable design bases.		

Previous NRC Exam Use	None
-----------------------	------

K/A Reference(s)

<CM 241657(1002)><<295037.EK3.02> >	Safety Function 1	Tier 1	Group 1	RO Imp: 4.3*	SRO Imp: 4.5*
<CM 241655(1001)><<Knowledge of the reasons for the following responses as they apply to SCRAM CONDITION PRESENT AND REACTOR POWER ABOVE APRM DOWNSCALE OR UNKNOWN : (CFR: 41.5 / 45.6)>> <CM 241657(1001)><<SBLC injection>>					

Learning Objective(s)

 <OB 1537836(1101)><<Q17 295037 EK 3.02 (NH)>>
 User (Sys) ID N/A (<OB 1537836(1125)><<1537836>>)

Cross Reference Links

None

Question 18	ID: 2151449	Points: 1.00
-------------	-------------	--------------

<QQ 2151449(1410)><<EOP-9, Radioactivity Release Control, has been entered following a plant transient. Turbine Building Ventilation (VT) is currently shutdown.

Why is restarting VT required?>>

- A. <QQ 2151449(1480)><<Ensure Turbine Building air is filtered prior to release to the environment.>>
- B. <QQ 2151449(1480)><<Ensure Turbine Building air is monitored prior to release to the environment.>>
- C. <QQ 2151449(1480)><<Ensure maximum safe operating radiation levels are not exceeded in the Turbine Building.>>
- D. <QQ 2151449(1480)><<Ensure maximum safe operating temperature levels are not exceeded in the Turbine Building.>>

Answer	<QQ 2151449(1419)><>
--------	-------------------------

Answer Explanation

<QQ 2151449(1412)><<B is correct.

Per Clinton EOP Technical Bases, "Turbine Building Ventilation should be operated to:

- Control temperature and radiation levels inside the turbine building
- Direct any radioactivity released from the turbine building through an elevated, monitored path

Since the turbine building is not air-tight, isolating the ventilation system could not only restrict personnel access, but could result in an unmonitored, ground level release of radioactivity."

Incorrect Responses:

A is incorrect but plausible. Several plant ventilation systems have filters, but VT does not.

C is incorrect but plausible. Maximum Safe operating conditions are monitored in EOP-8, not EOP-9. While the EOP Technical Bases state that VT should be operated to control radiation levels inside the turbine building, no mention is made of Max Safe conditions.

D is incorrect but plausible. Maximum Safe operating conditions are monitored in EOP-8, not EOP-9. While the EOP Technical Bases state that VT should be operated to control temperature levels inside the turbine building, no mention is made of Max Safe conditions.>>

Question Information

Topic	<QQ 2151449(1400)><<EOP-9, Radioactivity Release Control, has been entered following a plant transient. Turbine Buildi>>				
User ID	<QQ 2151449(1404)><<CL-ILT-N19018>>		System ID	<QQ 2151449(1445)><<2151449>>	
Status	<QQ 2151449(1405)><<Active>>	Point Value	<QQ 2151449(1441)><<1.00>>	Time (min)	<QQ 2151449(1408)><<0>>

Open or Closed Reference	<QQ 2151449(1409)><<CLOSED>>
Operator Type_Cognitive Level	<QQ 2151449(1415)><<RO-MEMORY>>
Operator Discipline	<QQ 2151449(1413)><<LO-I>>
10CFR55 Content	<TB 479394(1305)><<CFR: 41.9 Shielding, isolation, and containment design features, including access limitations.>>

References Provided	None
K/A Justification	Question meets the KA because the candidate must determine actions to be taken for protection of the general public from release of radioactivity during a high radioactivity condition.
SRO-Only Justification	N/A
Additional Information	Question is low cog written at the memory level. Candidate must recall facts and information contained in a procedure (1-F).

NRC Exams Only			
Question Type	Bank (CL-ILT-7009)	Difficulty	N/A
Technical Reference and Revision #	• EOP-TB Rev. 7		
Training Objective	LP87543.01.07Describe mechanisms for controlling radioactive releases		
Previous NRC Exam Use	None		

K/A Reference(s)

<CM 241680(1002)><<295038.EK1.02>>	Safety Function 9	Tier 1	Group 1	RO Imp: 4.2*	SRO Imp: 4.4*
<CM 241678(1001)><<Knowledge of the operational implications of the following concepts as they apply to HIGH OFF-SITE RELEASE RATE : (CFR: 41.8 to 41.10)>>					
<CM 241680(1001)><<†Protection of the general public>>					

Learning Objective(s)

 <OB 1537837(1101)><<Q18 295038 EK1.02 (BL)>>
User (Sys) ID N/A (<OB 1537837(1125)><<1537837>>)

Cross Reference Links

None

Question 19	ID: 2166915	Points: 1.00
-------------	-------------	--------------

<QQ 2166915(1410)><<The plant was operating at rated thermal power (RTP).

THEN, an alarm was received on MCR Panel 1H13-P841 indicating receipt of a fire alarm on XL3 Panel 1FP43J (located in Control Building 781').

The Equipment Operator dispatched to investigate the alarm reports that infrared device (B) 11-04 in the Drywell is alarming.

- (1) What components may have caught fire?
- (2) What action is required from the MCR?>>

- A. <QQ 2166915(1480)><<(1) Reactor Recirculation (RR) Pump motors.
(2) Manually start the 'A' AND 'B' Diesel Fire Pumps to ensure adequate fire protection water pressure to the drywell.>>
- B. <QQ 2166915(1480)><<(1) Reactor Recirculation (RR) Pump motors.
(2) Close the breakers for 1FP051, 54, 78, and 79 FP Cnmt (DW) Otbd (Inbd) Isolation Valves to allow the MCR to pressurize the Containment/Drywell FP header.>>
- C. <QQ 2166915(1480)><<(1) Main Steam Isolation Valve (MSIV) inboard actuators.
(2) Manually start the 'A' AND 'B' Diesel Fire Pumps to ensure adequate fire protection water pressure to the drywell.>>
- D. <QQ 2166915(1480)><<(1) Main Steam Isolation Valve (MSIV) inboard actuators.
(2) Close the breakers for 1FP051, 54, 78, and 79 FP Cnmt (DW) Otbd (Inbd) Isolation Valves to allow the MCR to pressurize the Containment/Drywell FP header.>>

Answer	<QQ 2166915(1419)><>
--------	-------------------------

Answer Explanation

<QQ 2166915(1412)><<B is correct.

CPS 1893.04 Fire Fighting Appendix J Drywell Fire - MCR Actions, note before step 1 states the following:

"The following information can be used to determine if there is a fire in the Drywell and the fires potential location. Device (B) 11-04 is the only device located in the Drywell. It receives an input from two infrared detectors. Each detector looks for flames emanating from the Reactor Recirc Pump Motors. If device (B) 11-04 alarms, MCR personnel will have to determine which RR Pump Motor is the cause for the alarm. This can be done by looking at RR Pump Motor temperatures on DCS. RR Pump A is at AZM 140 (SE Quadrant) and RR Pump B is at AZM 328 (NW Quadrant)."

Per CPS 3213.01E001 Fire Detection And Protection Electrical Lineup, the following valves are normally closed with the motor operator breakers turned off:

- 1FP051 FP Cnmt Otbd Isol Valve

- 1FP054 FP Cnmt Otbd Isol Valve
- 1FP078 FP DW Otbd Isol Valve
- 1FP079 FP DW Inbd Isol Valve

CPS 1893.04 Fire Fighting step 8.1.7 requires the breakers for 1FP051, 54, 78, and 79 to be turned on (locally) and then the valves opened from the MCR. This will allow alignment of the Fire Protection (FP) Water System to the containment for fire fighting operations.

Incorrect Responses:

A is incorrect but plausible. The first part of the response is correct; however, CPS 1893.04 step 8.1.6 directs starting a single fire pump if one is not running. Two fire pumps are not necessary to provide adequate water pressure to the drywell.

C is incorrect but plausible because the inboard MSIVs are located in the drywell and susceptible to arcing and potential fires during plant operation. The MSIV actuators are not monitored by infrared flame detectors in the drywell. The only device located in the drywell monitors the RR Pump Motors. Additionally, CPS 1893.04 step 8.1.6 directs starting a single fire pump if one is not running. Two fire pumps are not necessary to provide adequate water pressure to the drywell.

D is incorrect but plausible because the inboard MSIVs are located in the drywell and susceptible to arcing and potential fires during plant operation. The MSIV actuators are not monitored by infrared flame detectors in the drywell. The only device located in the drywell monitors the RR Pump Motors. The second part of the response is correct.>>

Question Information

Topic	<QQ 2166915(1400)><<The plant was operating at rated thermal power (RTP). THEN, an alarm was received on MCR Panel>>				
User ID	<QQ 2166915(1404)><<CL-ILT-N19019>>			System ID	<QQ 2166915(1445)><<2166915>>
Status	<QQ 2166915(1405)><<Active>>	Point Value	<QQ 2166915(1441)><<1.00>>	Time (min)	<QQ 2166915(1408)><<0>>

Open or Closed Reference	<QQ 2166915(1409)><<CLOSED>>
Operator Type_Cognitive Level	<QQ 2166915(1415)><<RO-MEMORY>>
Operator Discipline	<QQ 2166915(1413)><<LO-I>>
10CFR55 Content	<TB 479392(1305)><<CFR: 41.7 Design, components, and functions of control and safety systems, including instrumentation, signals, interlocks, failure modes, and automatic and manual features.>>

References Provided	None.
K/A Justification	Question meets the KA because the candidate must demonstrate knowledge of the relationship

	between a plant fire and the sensor detecting it.
SRO-Only Justification	N/A
Additional Information	Question is low cog, written at the memory level. The candidate must recall facts and information contained in a procedure (1-F).

NRC Exams Only			
Question Type	Bank (CL-ILT-N15014)	Difficulty	N/A
Technical Reference and Revision #	<ul style="list-style-type: none"> CPS 1893.04 Rev. 19c 		
Training Objective	<p>286000.03 DESCRIBE the function, operation, interlocks, trips, physicallocation, and power supplies of the following FP FD FIRE PROTECTION - DETECTION System components.</p> <ol style="list-style-type: none"> .1 Diesel Fire Pump A/B .2 Fire Protection Jockey Pump .3 Pre-action system .4 Deluge system .5 Wet Pipe Sprinkler system .6 Plant Service Water-Fire Protection (WS/FP) Cross Tie .7 Transformer Cooling Fan-Deluge System Interlock .8 CO2 Tanks .9 CO2 to Div I, II, and III EDG .10 CO2 to Main Generator Alterex Exciter .11 MCR Multizone Controller .12 Reserve Halon Bottles .13 Main Halon Bottles .14 Main Control Room Fire Protection System .15 RAT/ERAT SVC Fire Protection Control Panels .16 WPS Alarm Check Valve .17 FP Containment Isolation Valves .18 Standpipes .19 Fire Dampers .20 Diesel Fire Pump Day Tanks .21 Smoke Detectors .22 Heat Detectors .23 SVC Fire Protection System .24 Protectowire Detectors 		

	.25 Infrared Detectors
Previous NRC Exam Use	ILT 15-1 NRC

K/A Reference(s)

<CM 241876(1002)><<600000.AK2.01>>	Safety Function 8	Tier 1	Group 1	RO Imp: 2.6	SRO Imp: 2.7
<CM 241875(1001)><<Knowledge of the interrelations between PLANT FIRE ON SITE and the following:>> <CM 241876(1001)><<Sensors / detectors and valves>>					

Learning Objective(s)

 <OB 1537838(1101)><<Q19 600000 AK2.01 (BL)>>
 User (Sys) ID N/A (<OB 1537838(1125)><<1537838>>)

Cross Reference Links

Table: <TB 775424(1301)><<TRAINING - QUESTIONS - Track Questions Modified in this Project (CL-OPS-EXAM-ILT)>>
<TB 776664(1305)><<Tracking link in project CL-OPS-EXAM-ILT to source question 2151447>>

Question 20	ID: 2151454	Points: 1.00
-------------	-------------	--------------

<QQ 2151454(1410)><<CPS is operating under high summer loading conditions.

The Transmission System Operator has just notified CPS of a Degraded Grid condition.

Which one of the following actions is directed to be performed per OP-CL-108-107-1002, Degraded Grid Actions, and why?>>

- A. <QQ 2151454(1480)><<Shut down the Electrode Boilers, if operating, to reduce load on the grid.>>
- B. <QQ 2151454(1480)><<Transfer the Safety-related Busses to their Diesel Generators to reduce loading on the grid.>>
- C. <QQ 2151454(1480)><<Start the Shutdown Service Water (SX) pumps to ensure further grid degradation will NOT cause a loss of cooling.>>
- D. <QQ 2151454(1480)><<Transfer the Non-Safety related busses to their reserve source (RAT) to ensure they will NOT lose power if the plant trips.>>

Answer	<QQ 2151454(1419)><<A>>
--------	-------------------------

Answer Explanation

<QQ 2151454(1412)><<A is correct.

Per OP-CL-108-107-1002 4.3.3.7.f directs securing considering securing several non-essential loads, including the Auxiliary Boilers (Electrode Boilers), to help reduce load on the grid. Notification of degraded grid condition indicates a challenge to maintaining generator and grid voltage due to an electrical grid disturbance or other problem that dictates action be taken to improve reliability.

Incorrect Responses:

B is incorrect but plausible. While transferring that the safety busses to their respective DGs would help reduce load on the grid, OP-CL-108-107-1002 step 4.3.3.5 states to maximize the availability of the Diesel Generators. They are left in standby in case of a plant emergency.

C is correct but plausible. Loss of cooling to safety equipment is a concern; however, OP-CL-108-107-1002 step 4.3.3 3 directs refraining from starting any large loads (like the SX pumps) that may have the potential of inducing a transient on the grid

D is incorrect but plausible. Continuity of power to electrical buses is a priority; however, OP-CL-108-107-1002 step 4.3.3 4 directs not manually transferring any bus that could place a transient on the grid.>>

Question Information

Topic	<QQ 2151454(1400)><<CPS is operating under high summer loading conditions. The Transmission System Operator has just>>				
User ID	<QQ 2151454(1404)><<CL-ILT-N19020>>		System ID	<QQ 2151454(1445)><<2151454>>	
Status	<QQ 2151454(1405)><<Active>>	Point Value	<QQ 2151454(1441)><<1.00>>	Time (min)	<QQ 2151454(1408)><<0>>

Open or Closed Reference	<QQ 2151454(1409)><<CLOSED>>
Operator Type_Cognitive Level	<QQ 2151454(1415)><<RO-MEMORY>>
Operator Discipline	<QQ 2151454(1413)><<LO-I>>
10CFR55 Content	<TB 479390(1305)><<CFR: 41.5 Facility operating characteristics during steady state and transient conditions, including coolant chemistry, causes and effects of temperature, pressure and reactivity changes, effects of load changes, and operating limitations and reasons for these operating characteristics.>>

References Provided	None
K/A Justification	Question meets the KA because the candidate must demonstrate knowledge of actions to be taken in the Degraded Grid procedure for the electric grid disturbance given in the stem.
SRO-Only Justification	N/A
Additional Information	Question is low cog, written at the memory level. Candidate must recall facts and information contained in a procedure (1-F).

NRC Exams Only			
Question Type	Bank (CL-ILT-A11045)	Difficulty	N/A
Technical Reference and Revision #	OP-CL-108-107-1002 Rev. 6c		
Training Objective	LP85382-RNS 3 Describe the actions necessary to mitigate off-normal voltage conditions		
Previous NRC Exam Use	None		

K/A Reference(s)

<CM 275365(1002)><<700000.AK3.02>>	Safety Function 8	Tier	Group	RO Imp: 3.6	SRO Imp: 3.9
<CM 275363(1001)><<Knowledge of the reasons for the following responses as they apply to GENERATOR VOLTAGE AND ELECTRIC GRID DISTURBANCES: (CFR: 41.4, 41.5, 41.7, 41.10 / 45.8)>><CM 275365(1001)><<Actions contained in abnormal operating procedure for voltage and grid disturbances>>					

Learning Objective(s)

 <OB 1537839(1101)><<Q20 700000 AK3.02 (BL)>>
 User (Sys) ID N/A (<OB 1537839(1125)><<1537839>>)

Cross Reference Links

None

Question 21	ID: 2151469	Points: 1.00
-------------	-------------	--------------

<QQ 2151469(1410)><<CPS is operating at rated thermal power.

Which of the following alarms will lead to a degradation of main condenser vacuum?>>

- A. <QQ 2151469(1480)><<5067-3E MAIN STEAM LINE DIV 1,4 RADN HIGH-HIGH OR INOP.>>
- B. <QQ 2151469(1480)><<1RIX-PR034 OFF-GAS PRE-TREAT PRM TB 805' D-104 CH-1 backlit in RED.>>
- C. <QQ 2151469(1480)><<1RIX-PR035 OFF-GAS POST-TREAT PRM #1 RW 702' F-125 CH-7 backlit in RED.>>
- D. <QQ 2151469(1480)><<1RIX-PR041 OFF-GAS POST-TREAT PRM #2 RW 702' F-125 CH-7 backlit in YELLOW.>>

Answer	<QQ 2151469(1419)><<C>>
--------	-------------------------

Answer Explanation

<QQ 2151469(1412)><<C is correct.

Per 5140.46 AR/PR Annunciator - Off-Gas Post-Treat PRM #1 1RIX-PR035, Hi Rad alarm (red background) on CH-7 of 1RIX-PR035 or 1RIX-PR041 is an indication of potential fuel failure and will result in closing of 1N66-F060, Gas Vent Disch Isol Valve. Flow from the steam jet air ejectors (SJAE) is directed to the Off-Gas system. When Off-Gas is isolated by closing 1N66-F060, flow from the SJAE is isolated and air and non-condensable gasses will build up in the main condenser, causing degradation of main condenser vacuum.

Incorrect Responses:

A is incorrect but plausible. High radiation in the main steam lines is an indication of fuel failure, and will trip both Mechanical Vacuum Pumps if running, but will not affect SJAE flow or vacuum given current plant conditions.

B is incorrect but plausible. High radiation detected in the OG pre-treatment portion is an indication of potential fuel failure but will not cause any automatic isolations or affect main condenser vacuum.

D is incorrect but plausible. Off-Gas Post-Treat PRM #2 1RIX-PR041, Alert alarm (yellow background) on CH-7 of 1RIX-PR035 or 1RIX-PR041 is an indication of a potential fuel failure and will result in shifting the OG system to "Treat" mode, but will not affect main condenser vacuum.>>

Question Information

Topic	<QQ 2151469(1400)><<CPS is operating at rated thermal power. Which of the following alarms will lead to a degradat>>				
User ID	<QQ 2151469(1404)><<CL-ILT-N19021>>			System ID	<QQ 2151469(1445)><<2151469>>
Status	<QQ 2151469(1405)><<Active>>	Point Value	<QQ 2151469(1441)><<1.00>>	Time (min)	<QQ 2151469(1408)><<0>>

Open or Closed Reference	<QQ 2151469(1409)><<CLOSED>>
Operator Type_Cognitive Level	<QQ 2151469(1415)><<RO-HIGH>>
Operator Discipline	<QQ 2151469(1413)><<LO-I>>
10CFR55 Content	<TB 479392(1305)><<CFR: 41.7 Design, components, and functions of control and safety systems, including instrumentation, signals, interlocks, failure modes, and automatic and manual features.>>

References Provided	None
K/A Justification	Question meets the KA because the candidate must demonstrate knowledge of reason for a loss of air ejector flow - 1RIX-PR035 closes 1N66-F060 isolating flow from the SJAEs - and its relationship to main condenser vacuum.
SRO-Only Justification	N/A
Additional Information	Question is high cog written at the comprehension level. The candidate must recognize the interaction between the Main Condensate system and the Off-Gas system (2-RI)

NRC Exams Only			
Question Type	New	Difficulty	N/A
Technical Reference and Revision #	<ul style="list-style-type: none"> • CPS 5140.46 Rev. 2d • CPS 5140.47 Rev. 3d • CPS 4004.02 rev 7a 		
Training Objective	271000.16 EVALUATE the following OFFGAS indications/responses and DETERMINE if the indication/ response is expected and normal. .1 SJAЕ Steam Flow .2 Offgas Post-Treat Radiation		
Previous NRC Exam Use	None		

K/A Reference(s)

<CM 240537(1002)><<295002.AK3.06> >	Safety Function 3	Tier 1	Group 2	RO Imp: 2.9	SRO Imp: 2.9
<CM 240531(1001)><<Knowledge of the reasons for the following responses as they apply to LOSS OF MAIN CONDENSER VACUUM : (CFR: 41.5 / 45.6)>> <CM 240537(1001)><<Air ejector flow>>					

Learning Objective(s)

 <OB 1537840(1101)><<Q21 295002 AK3.06 (NH)>>
 User (Sys) ID N/A (<OB 1537840(1125)><<1537840>>)

Cross Reference Links

None

Question 22	ID: 2151506	Points: 1.00
-------------	-------------	--------------

<QQ 2151506(1410)><<The plant was operating at rated thermal power.

THEN, a Loss of Coolant Accident occurred.

Current plant conditions are as follows:

- Drywell Pressure reached 1.8 psig and is currently 1.1 psig.
- CCP exhaust radiation PRM exceeded 100 mR/hr and is currently 50 mR/hr.
- Containment temperature is 105°F and rising.

After placing the CNMT building supply and exhaust valve control switches to the CLOSE position, what additional steps are required to restore containment building ventilation?>>

- A. <QQ 2151506(1480)><<Momentarily place CNMT HVAC ISOL VLV RAD INTLK keylock switches to TOTAL BYPASS.>>
- B. <QQ 2151506(1480)><<Depress the OUTBD ISOLATION SEAL-IN reset and INBD ISOLATION SEAL-IN RESET push-buttons.>>
- C. <QQ 2151506(1480)><<Both A and B are required to reset these isolation signals.>>
- D. <QQ 2151506(1480)><<Neither A nor B are required. These isolation signals automatically reset.>>

Answer	<QQ 2151506(1419)><<C>>
--------	-------------------------

Answer Explanation

<QQ 2151506(1412)><<C is correct.

Per CPS 4001.02, Automatic Isolation, section 4.10.3.1, resetting Group 10 signals requires:

- first placing the applicable valve control switches to the CLOSE position, then momentarily place CNMT HVAC ISOL VLV RAD INTLK keylock switches to TOTAL BYPASS (for an isolation caused by HVAC High Rad signals), or
- depressing the OUTBD ISOLATION SEAL-IN reset and INBD ISOLATION SEAL-IN RESET push-buttons (for an isolation NOT caused by HVAC High Rad signals).

Conditions in the stem indicate that the isolations occurred on both high drywell pressure and HVAC high radiation. As a result, BOTH of the above actions must be performed to reset the isolation.

Incorrect Responses:

A is incorrect but plausible. Momentarily placing CNMT HVAC ISOL VLV RAD INTLK keylock switches to TOTAL BYPASS will reset the isolation caused by the HVAC high radiation, but not the high drywell

pressure trip.

B is incorrect but plausible. Depressing the OUTBD ISOLATION SEAL-IN reset and INBD ISOLATION SEAL-IN RESET push-buttons will reset the isolation caused by the high drywell pressure, but not the HVAC High Rad trip.

D is incorrect but plausible. The Group 9 signal, which closes the containment building ventilation isolation bypass valves, automatically resets when the condition clears.>>

Question Information

Topic	<QQ 2151506(1400)><<The plant was operating at rated thermal power. THEN, a Loss of Coolant Accident occurred. >>				
User ID	<QQ 2151506(1404)><<CL-ILT-N19022>>			System ID	<QQ 2151506(1445) ><<2151506>>
Status	<QQ 2151506(1405) ><<Active>>	Point Value	<QQ 2151506(1441) ><<1.00>>	Time (min)	<QQ 2151506(1408) ><<0>>

Open or Closed Reference	<QQ 2151506(1409)><<CLOSED>>
Operator Type_Cognitive Level	<QQ 2151506(1415)><<RO-HIGH>>
Operator Discipline	<QQ 2151506(1413)><<LO-I>>
10CFR55 Content	<TB 479392(1305)><<CFR: 41.7 Design, components, and functions of control and safety systems, including instrumentation, signals, interlocks, failure modes, and automatic and manual features.>>

References Provided	None
K/A Justification	Question meets the KA because the candidate must demonstrate the ability to operate the containment ventilation system to lower containment temperature following a ventilation trip.
SRO-Only Justification	N/A
Additional Information	Question is high cog, written at the comprehension level. The candidate must analyze the stem of the question to determine why isolations occurred and then recognize which actions are required to restore ventilation (2-RI).

NRC Exams Only			
Question Type	New	Difficulty	N/A

Technical Reference and Revision #	<ul style="list-style-type: none"> CPS 4001.02 Rev. 17f
Training Objective	288001.11 EVALUATE given key CONTAINMENT VENTILATION AND DRYWELL PURGE System parameters, if needed DETERMINE a course of action to correct or mitigate the following abnormal condition(s): <ul style="list-style-type: none"> .1 CCP Supply Fan Trip .2 CCP Exhaust Fan Trip .3 CBV Supply Fan Trip .4 CBV Exhaust Fan Trip .5 High Low Differential Pressure Containment Building
Previous NRC Exam Use	None

K/A Reference(s)

<CM 240809(1002)><<295011.AA1.01>>	Safety Function 5	Tier 1	Group 2	RO Imp: 3.6	SRO Imp: 3.9
<CM 240808(1001)><<Ability to operate and/or monitor the following as they apply to HIGH CONTAINMENT TEMPERATURE (MARK III CONTAINMENT ONLY) : (CFR: 41.7 / 45.6)>>> <CM 240809(1001)><<Containment ventilation/cooling system: Mark-III>>					

Learning Objective(s)

 <OB 1537841(1101)><<Q22 295011 AA1.01 (BH)>>>
 User (Sys) ID N/A (<OB 1537841(1125)><<1537841>>)

Cross Reference Links

None

Question 23	ID: 2152984	Points: 1.00
-------------	-------------	--------------

<QQ 2152984(1410)><<CPS is operating at rated thermal power with NO testing in progress.

THEN, rising Suppression Pool temperature results in entry into EOP-6, Primary Containment Control. Suppression Pool temperature is still rising slowly.

What are the current Suppression Pool temperature logging requirements?>>

- A. <QQ 2152984(1480)><<Every 5 minutes to verify temperature is < 103.7°F.>>
- B. <QQ 2152984(1480)><<Every 30 minutes to verify temperature is < 118.7°F.>>
- C. <QQ 2152984(1480)><<Hourly to verify temperature is < 108.7°F.>>
- D. <QQ 2152984(1480)><<Nightly to verify temperature is < 95°F.>>

Answer	<QQ 2152984(1419)><<C>>
--------	-------------------------

Answer Explanation

<QQ 2152984(1412)><<C is correct.

EOP-6 entry is required for a suppression pool temperature of > 95°F. CPS 9000.05 SUPPRESSION POOL TEMPERATURE LOG section 5.3 requires logging temperature every < 1 hour to verify temperature is < 108.7°F when suppression pool temperature is > 95°F. CPS 5064.5C, Alarm Panel 5064 Annunciators – Row 5 directs entry to ITS actions to log suppression pool temperature hourly under the conditions given in the stem.

Incorrect responses:

A is incorrect but plausible. This recording interval and temperature limit is required during testing which adds heat to the Suppression Pool.

B is incorrect but plausible. This recording interval and temperature limit is required following placement of the Mode Switch in shutdown position with suppression pool average water temperature > 108.7°F with no testing in progress which will add heat to the Suppression Pool.

D is incorrect but plausible. This recording interval and temperature limit is the normal required frequency, with no testing in progress which will add heat to the Suppression Pool.>>

Question Information

Topic	<QQ 2152984(1400)><<CPS is operating at rated thermal power with NO testing in progress. THEN, rising Suppression Po>>				
User ID	<QQ 2152984(1404)><<CL-ILT-N19023>>			System ID	<QQ 2152984(1445)><<2152984>>
Status	<QQ 2152984(1405)><<Active>>	Point Value	<QQ 2152984(1441)><<1.00>>	Time (min)	<QQ 2152984(1408)><<0>>

Open or Closed Reference	<QQ 2152984(1409)><<CLOSED>>
Operator Type_Cognitive Level	<QQ 2152984(1415)><<RO-MEMORY>>
Operator Discipline	<QQ 2152984(1413)><<LO-I>>
10CFR55 Content	<TB 479392(1305)><<CFR: 41.7 Design, components, and functions of control and safety systems, including instrumentation, signals, interlocks, failure modes, and automatic and manual features.>>

References Provided	None
K/A Justification	Question meets the KA because the candidate must determine how frequently to document Suppression Pool temperature during an elevated Suppression Pool temperature condition.
SRO-Only Justification	N/A
Additional Information	Question is low cog written at the memory level. The candidate must determine that Suppression Pool temperature has exceeded 95°F and then recall how often logging it is required (1-F).

NRC Exams Only			
Question Type	New	Difficulty	N/A
Technical Reference and Revision #	<ul style="list-style-type: none"> • CPS 9000.05 Rev. 27b • CPS 9056.02 Rev. 29c • CPS 9000.01D001 Rev. 58c 		
Training Objective	LP85801.2.1.18 Ability to make accurate / clear and concise logs / records / status boards / and reports.		
Previous NRC Exam Use	None		

K/A Reference(s)

<CM 240838(1002)><<295013.AA1.01>>	Safety Function 5	Tier 1	Group 2	RO Imp: 3.9	SRO Imp: 3.9
<CM 240837(1001)><<Ability to operate and/or monitor the following as they apply to HIGH SUPPRESSION POOL TEMPERATURE : (CFR: 41.7 / 45.6)>> <CM 240838(1001)><<Suppression pool cooling>>					

Learning Objective(s)

 <OB 1537842(1101)><<Q23 295013 AA1.01 (NL)>>
 User (Sys) ID N/A (<OB 1537842(1125)><<1537842>>)

Cross Reference Links

Table: <TB 775424(1301)><<TRAINING - QUESTIONS - Track Questions Modified in this Project (CL-OPS-EXAM-ILT)>>
<TB 776064(1305)><<Tracking link in project CL-OPS-EXAM-ILT to source question 2152062>>

Question 24	ID: 2151509	Points: 1.00
-------------	-------------	--------------

<QQ 2151509(1410)><<CPS was operating at rated thermal power when an automatic scram occurred.

The SCRAM VALVES pushbutton on the Display Selection Matrix at P680 is currently backlit red.

Upon depressing the SCRAM VALVES pushbutton, all control rods have green LEDs illuminated on the full core display except for control rod 33-12, which has NO light lit.

What is the status of the control rod 33-12 scram valves?

Control rod 33-12...>>

- A. <QQ 2151509(1480)><<scram valves have lost continuity.>>
- B. <QQ 2151509(1480)><<is the only rod that has both scram valves shut.>>
- C. <QQ 2151509(1480)><<is the only rod that has both scram valves open.>>
- D. <QQ 2151509(1480)><<has one scram valve open and one scram valve shut.>>

Answer	<QQ 2151509(1419)><>
--------	-------------------------

Answer Explanation

<QQ 2151509(1412)><<B is correct.

Per CPS 3304.02 Rod Control and Information System, section 8.1.8.5, the SCRAM VALVES pushbutton is backlit to indicate that at least one rod has a scram valve whose position is different from the other scram valves. Depressing the pushbutton will give the following status indications for each control rod: green to indicate both insert and exhaust scram valves have opened, red to indicate that all scram valves on the HCU are not in the same state, and de-energized to indicate that both insert and exhaust valves on the HCU are shut.

Incorrect Responses:

A is incorrect but plausible. Having the status light de-energized may seem like continuity was lost, for example the Standby Liquid Control system squib valve indicator lights de-energize when valve continuity is lost. However, in this case it indicates that both insert and exhaust scram valves on the HCU are shut per CPS 3304.02.

C is incorrect but plausible. The status light de-energized may seem to indicate that both scram valves are open, and green lights are typically used for plant valve closed indications; however, this is not the case with scram valve indication at the Display Selection Matrix at P680. Both lights de-energized indicates that both insert and exhaust scram valves on the HCU are shut per CPS 3304.02.

D is incorrect but plausible. A red status light would indicate that all scram valves on the HCU are not in the same state. Both lights de-energized indicates that both insert and exhaust scram valves on the HCU are shut per CPS 3304.02.>>

Question Information

Topic	<QQ 2151509(1400)><<CPS was operating at rated thermal power when an automatic scram occurred. The SCRAM VALVES pu>>				
User ID	<QQ 2151509(1404)><<CL-ILT-N19024>>		System ID	<QQ 2151509(1445)>><<2151509>>	
Status	<QQ 2151509(1405)>><<Active>>	Point Value	<QQ 2151509(1441)>><<1.00>>	Time (min)	<QQ 2151509(1408)>><<0>>

Open or Closed Reference	<QQ 2151509(1409)><<CLOSED>>
Operator Type_Cognitive Level	<QQ 2151509(1415)><<RO-MEMORY>>
Operator Discipline	<QQ 2151509(1413)><<LO-I>>
10CFR55 Content	<TB 479385(1305)><<10 CFR 55.41 RO WRITTEN EXAMINATION>>

References Provided	None
K/A Justification	Question meets the KA because the candidate must use scram valve indications to determine that not all rods have inserted and therefore an incomplete scram has occurred.
SRO-Only Justification	N/A
Additional Information	Question is low cog written at the memory level. The candidate must recall facts and information contained in a procedure (1-F).

NRC Exams Only			
Question Type	New	Difficulty	N/A
Technical Reference and Revision #	<ul style="list-style-type: none"> CPS 3304.02 Rev. 23 		
Training Objective	201002.15 Given RC&IS System initial conditions, PREDICT how the system and/or plant parameters will respond to the manipulation of the following controls. <ol style="list-style-type: none"> .1 Test Display Pushbutton .2 Data Fault Pushbutton .3 SUBST POSITION Pushbutton .4 DRIVE BYPASSED Pushbutton .5 SCRAM VALVES Pushbutton .6 ACCUM FAULT Pushbutton .7 POSITION BYPASSED Pushbutton .8 LPRM BYPASSED Pushbutton 		

	.9 ROD UNCOUPLED Pushbutton .10 ROD DRIFT Pushbutton .11 INSERT OK Pushbutton .12 WITHDRAW OK Pushbutton .13 SELECT ROD INSERT Pushbutton .14 SELECTED HALF Pushbutton .15 SELECTED GROUP Pushbutton .16 ALL RODS Pushbutton .17 ACK ACCUM FAULT Pushbutton .18 CHAN 1 DATA/CHAN 2 DATA Pushbutton .19 INDIVID DRIVE GANG DRIVE Pushbutton .20 RESET DRIFT Pushbutton .21 DATA SOURCE Pushbutton .22 DRIVE MODE Pushbutton .23 TEST DRIFT Pushbutton .24 DATA MODE Pushbutton .25 RAW DATA Pushbutton .26 ROD SELECT CLEAR Pushbutton
Previous NRC Exam Use	None

K/A Reference(s)

<CM 240902(1002)><<295015.AA2.02>>	Safety Function 1	Tier 1	Group 2	RO Imp: 4.1*	SRO Imp: 4.2*
<CM 240900(1001)><<Ability to determine and/or interpret the following as they apply to INCOMPLETE SCRAM : (CFR: 41.10 / 43.5 / 45.13)>> <CM 240902(1001)><<Control rod position>>					

Learning Objective(s)

 <OB 1537843(1101)><<Q24 295015 AA2.02 (NL)>>
 User (Sys) ID N/A (<OB 1537843(1125)><<1537843>>)

Cross Reference Links

None

Question 25	ID: 2151522	Points: 1.00
-------------	-------------	--------------

<QQ 2151522(1410)><<Spent fuel movements were in progress in the Fuel Building.

The following indications have been observed on the MCR AR/PR LAN:

Fuel Building Exhaust Radiation Monitors:

- 1RIX-PR006A RED
- 1RIX-PR006B YELLOW
- 1RIX-PR006C RED
- 1RIX-PR006D YELLOW

Spent Fuel Storage ARM 1RIX-AR016:

- 1RIX-AR016 RED

(1) Which of the following identifies the status of the SGTS Accident Range (AXM) Monitor 0RIX-PR008?

AND

(2) What action should the operating crew take next?>>

- A. <QQ 2151522(1480)><<(1) Standby Mode
(2) Enter EOP-9, Radioactivity Release Control>>
- B. <QQ 2151522(1480)><<(1) Standby Mode
(2) Notify RP>>
- C. <QQ 2151522(1480)><<(1) Operating Mode
(2) Enter EOP-9, Radioactivity Release Control>>
- D. <QQ 2151522(1480)><<(1) Operating Mode
(2) Notify RP>>

Answer	<QQ 2151522(1419)><<D>>
--------	-------------------------

Answer Explanation

<QQ 2151522(1412)><<D is correct:

The conditions provided in the stem show radiation levels are elevated FB 755' as indicated by alert and high alarms on 1RIX-PR006A-D and 1RIX-AR016. This requires entry into CPS 4979.01, Abnormal Release of Airborne Reactivity. The required immediate operator actions of 4979.01 re-verifying RP and the MCR are aware of the condition.

Per 5140.63 AR/PR ANNUNCIATOR - FUEL BUILDING EXHAUST 1RIX-PR006 A,B,C,D, a trip of 1RIX-

PR006A or B coincident with a trip of 1RIX-PR006C or D will cause automatic isolations of Group 19 (VF) and automatic start of VG A and B. The SGTS AXM 0RIX-PR008 is verified in operation when VG auto initiates per CPS 3319.01 Standby Gas Treatment (VG), section 8.3.1 Automatic Initiation.

Incorrect Responses:

A is incorrect. A plausible misconception is that 0RIX-PR008 does not shift to Operating Mode when VG auto initiates. Additionally, although EOP-9 entry is required if an offsite release of radioactivity is occurring, the entry conditions have not been met based on stem conditions.

B is incorrect but plausible. A plausible misconception is that 0RIX-PR008 does not shift to Operating Mode when VG auto initiates. 0RIX-PR008 shifts to Operating Mode when VG auto initiates. RP notification is correct.

C is incorrect but plausible. While 0RIX-PR008 does shift to Operating Mode, the second part of this answer is incorrect. Although EOP-9 entry is required if an offsite release of radioactivity is occurring, the entry conditions have not been met based on stem conditions.>>

Question Information

Topic	<QQ 2151522(1400)><<Spent fuel movements were in progress in the Fuel Building. The following indications have been >>				
User ID	<QQ 2151522(1404)><<CL-ILT-N19025>>			System ID	<QQ 2151522(1445)><<2151522>>
Status	<QQ 2151522(1405)><<Active>>	Point Value	<QQ 2151522(1441)><<1.00>>	Time (min)	<QQ 2151522(1408)><<0>>

Open or Closed Reference	<QQ 2151522(1409)><<CLOSED>>
Operator Type_Cognitive Level	<QQ 2151522(1415)><<RO-HIGH>>
Operator Discipline	<QQ 2151522(1413)><<LO-I>>
10CFR55 Content	<TB 479392(1305)><<CFR: 41.7 Design, components, and functions of control and safety systems, including instrumentation, signals, interlocks, failure modes, and automatic and manual features.>>

References Provided	None
K/A Justification	Question meets the KA because the candidate must interpret high radiation alarms and determine how the AR/PR system will operate in response and recognize required operator actions for the high radiation condition.
SRO-Only Justification	N/A
Additional Information	Question is high cog written at the analysis and comprehension level. The candidate must recall

	radiation monitor setpoints and then apply them to determine status of the accident range radiation monitor and required immediate actions (2-RI).
--	--

NRC Exams Only			
----------------	--	--	--

Question Type	New	Difficulty	N/A
---------------	-----	------------	-----

Technical Reference and Revision #	<ul style="list-style-type: none"> • CPS 3319.01 Rev. 17c • CPS 5140.63 Rev. 1c • CPS 4979.01 Rev. 10f
------------------------------------	---

Training Objective	<p>272000.03 DESCRIBE the function, operation, interlocks, trips, and power supplies of the following AR/PR System components.</p> <ol style="list-style-type: none"> 1 Area Radiation Monitors (ARMs) 2 Continuous Air Monitors (CAMs) 3 Main Steam Line Radiation Monitors (MSLRMs) 4 Containment Building Continuous Containment Purge (CCP) Duct Monitors 5 Containment Building Fuel Transfer Pool Vent Plenum Monitors 6 Containment Building Exhaust Duct Monitors 7 Fuel Building (FB) Exhaust Vent Plenum Monitors 8 Main Control Room Air Intake Monitors 9 HVAC Exhaust Stack Monitors 10 SGTS Exhaust Stack Monitors 11 Pre-Treatment Offgas Monitor 12 Post Treatment Offgas Monitors 13 HVAC Accident Range (AXM) Monitor 14 SGTS Accident Range (AXM) Monitor 15 Fuel Pool Cooling & Cleanup (FC) Heat Exchanger (HX) 1A (1B) WS Effluent Monitors 16 Plant Service Water (WS) Effluent Monitor 17 Component Cooling Water (CC) HX Monitor 18 Shutdown Service Water (SX) Effluent Monitors 19 Liquid Radwaste Discharge Monitor
--------------------	--

Previous NRC Exam Use	None
-----------------------	------

K/A Reference(s)

<CM 275328(1002)><<B2.2.44>>	Safety Function 1	Tier 3	Group	RO Imp: 4.2	SRO Imp: 4.4
<CM 275328(1001)><<Ability to interpret control room indications to verify the status and operation of a system, and understand how operator actions and directives affect plant and system conditions. (CFR: 41.5 / 43.5 / 45.12)>>					
<CM 246585(1002)><<GS.295017>>	Safety Function 9	Tier 1	Group 2	RO Imp:	SRO Imp:
<CM 246585(1001)><<High Off-Site Release Rate>>					

Learning Objective(s)

 <OB 1537844(1101)><<Q25 295017 2.2.44 (NH)>>
 User (Sys) ID N/A (<OB 1537844(1125)><<1537844>>)

Cross Reference Links

None

Question 26	ID: 2154955	Points: 1.00
-------------	-------------	--------------

<QQ 2154955(1410)><<The plant is operating at rated thermal power (RTP).

THEN, a transient occurred resulting in entry into EOP-6 Primary Containment Control.

Which of the following would improve margin to the SRV Tailpipe Limit?>>

- A. <QQ 2154955(1480)><<Raise RPV pressure.>>
- B. <QQ 2154955(1480)><<Lower containment temperature.>>
- C. <QQ 2154955(1480)><<Lower Suppression Pool water level.>>
- D. <QQ 2154955(1480)><<Lower Suppression Pool water temperature.>>

Answer	<QQ 2154955(1419)><<C>>
--------	-------------------------

Answer Explanation

<QQ 2154955(1412)><<C is correct.

Per the Emergency Operating Procedures Technical Bases (EOP-TB), the SRV Tail Pipe Level Limit is a function of RPV pressure. SRV operation with the suppression pool level above the SRV Tail Pipe Level Limit could damage the SRV discharge lines.

Transferring suppression pool water to Cycled Condensate (CY) will lower suppression pool water level and increase margin to the SRV Tail Pipe Level Limit.

Incorrect Responses:

A is incorrect but plausible. Raising RPV pressure would reduce margin to the SRV Tailpipe Limit. Plausible since a higher pressure is desirable in other cases such as maintaining Minimum Steam Cooling Pressure.

B is incorrect but plausible. Lowering Containment temperature has no effect on the margin to the SRV Tailpipe Limit. Plausible since this action would also lower Containment pressure, improving margin to the Pressure Suppression Pressure limit.

D is incorrect but plausible. Lowering Suppression Pool water temperature has no effect on the margin to the SRV Tailpipe Limit. Plausible since this action would improve margin to the Heat Capacity Limit.>>

Question Information

Topic	<QQ 2154955(1400)><<The plant is operating at rated thermal power (RTP). THEN, a transient occurred resulting in ent>>				
User ID	<QQ 2154955(1404)><<CL-ILT-N19026>>		System ID	<QQ 2154955(1445)><<2154955>>	
Status	<QQ 2154955(1405)><<Active>>	Point Value	<QQ 2154955(1441)><<1.00>>	Time (min)	<QQ 2154955(1408)><<0>>

Open or Closed Reference	<QQ 2154955(1409)><<CLOSED>>
Operator Type_Cognitive Level	<QQ 2154955(1415)><<RO-MEMORY>>
Operator Discipline	<QQ 2154955(1413)><<LO-I>>
10CFR55 Content	<TB 479388(1305)><<CFR: 41.3 Mechanical components and design features of the reactor primary system.>>

References Provided	None
K/A Justification	Question meets the KA because the candidate must correctly state the effect a high suppression pool level has on pressure suppression capability, which directly impacts containment integrity.
SRO-Only Justification	N/A
Additional Information	Question is low cog written at the memory level. The candidate must recall facts from the EOP-TB (1-F).

NRC Exams Only			
Question Type	New	Difficulty	N/A
Technical Reference and Revision #	<ul style="list-style-type: none"> EOP-TB Rev. 7 		
Training Objective	LP87550.01.01 Recall the definition and bases for the following EOP Variables and Curves: .23 Heat Capacity Limit .25 Minimum Steam Cooling Pressure .30 Pressure Suppression Pressure .32 SRV Tail Pipe Limit		
Previous NRC Exam Use	None		

K/A Reference(s)

<CM 241390(1002)><<295029.EK1.01>>	Safety Function 5	Tier 1	Group 2	RO Imp: 3.4	SRO Imp: 3.7
<CM 241389(1001)><<Knowledge of the operational implications of the following concepts as they apply to HIGH SUPPRESSION POOL WATER LEVEL : (CFR: 41.8 to 41.10)>> <CM 241390(1001)><<Containment integrity>>					

Learning Objective(s)

 <OB 1537845(1101)><<Q26 295029 EK1.01 (NL)>>
 User (Sys) ID N/A (<OB 1537845(1125)><<1537845>>)

Cross Reference Links

None

Question 27	ID: 2166958	Points: 1.00
-------------	-------------	--------------

<QQ 2166958(1410)><<A plant transient has occurred requiring entry into EOP-6 Primary Containment Control due to rising containment hydrogen levels.

- Containment hydrogen level is 1.0% and rising.
- RPV level is - 160" and lowering.
- Suppression pool level is 13 feet and stable.

What combination of hydrogen igniters and hydrogen mixers should be started, if any?>>

- A. <QQ 2166958(1480)><<Mixers ONLY.>>
- B. <QQ 2166958(1480)><<Igniters ONLY.>>
- C. <QQ 2166958(1480)><<BOTH mixers and igniters.>>
- D. <QQ 2166958(1480)><<NEITHER mixers nor igniters.>>

Answer	<QQ 2166958(1419)><>
--------	-------------------------

Answer Explanation

<QQ 2166958(1412)><<B is correct.

Per EOP Technical Bases, if hydrogen production is anticipated, the igniters and mixers should be started as soon as possible, before a significant concentration of hydrogen can accumulate. Starting the igniters and mixers “before” RPV water level drops to the top of the active fuel ensures that they will be operating, if available, when hydrogen production begins. The mixers (HG) may be used only if suppression pool level is above 13 ft. 1 in. (13.1 ft). If suppression pool level were below 13 ft. 1 in. (13.1 ft), the mixer discharge would be uncovered and mixer operation would open a path from the drywell directly into the containment. A break in the drywell could then overpressurize the containment. Given stem conditions of RPV lowering to TAF and suppression pool level less than 13 ft 1 in., it is appropriate to start the hydrogen igniters but not the mixers.

Incorrect Responses:

A is incorrect but plausible since hydrogen mixers are frequently started together for similar plant conditions, and would be correct if suppression pool level was greater than 13 ft. 1 in.

C is incorrect but plausible because hydrogen mixers and igniters are frequently operated in conjunction with one another during EOP scenarios, and would be correct if suppression pool level was greater than 13 ft. 1 in.

D is incorrect but plausible because hydrogen concentration is below the lower flammability limits. Despite this, hydrogen igniters are required to be started per EOP-6.>>

Question Information

Topic	<QQ 2166958(1400)><<A plant transient has occurred requiring entry into EOP-6 Primary Containment Control due to rising>>				
User ID	<QQ 2166958(1404)><<CL-ILT-N19027>>		System ID	<QQ 2166958(1445)><<2166958>>	
Status	<QQ 2166958(1405)><<Active>>	Point Value	<QQ 2166958(1441)><<1.00>>	Time (min)	<QQ 2166958(1408)><<0>>

Open or Closed Reference	<QQ 2166958(1409)><<CLOSED>>
Operator Type_Cognitive Level	<QQ 2166958(1415)><<RO-MEMORY>>
Operator Discipline	<QQ 2166958(1413)><<LO-I>>
10CFR55 Content	<TB 479392(1305)><<CFR: 41.7 Design, components, and functions of control and safety systems, including instrumentation, signals, interlocks, failure modes, and automatic and manual features.>>

References Provided	None
K/A Justification	Question meets the KA because the candidate must demonstrate understanding of the operation of the containment atmosphere control system during a high hydrogen event.
SRO-Only Justification	N/A
Additional Information	Question is low cog written at the memory level. The candidate must recall facts and information contained in a procedure (1-P).

NRC Exams Only			
Question Type	New	Difficulty	N/A
Technical Reference and Revision #	EOP-TB, Rev. 7		
Training Objective	223003.05 Initial: From memory and in accordance with listed references unless otherwise stated, the trainee shall: Discuss the COMBUSTIBLE GAS CONTROL system automatic functions/interlocks including purpose, signals, set points, sensing points, when bypassed, how/when they are. .1 Drywell and Containment Atmosphere Hydrogen Mixing Compressors .3 CGCS Hydrogen Recombiners .4 Hydrogen Igniters		

Previous NRC Exam Use	None
-----------------------	------

K/A Reference(s)

<CM 241824(1002)><<500000.EK2.03>>	Safety Function 5	Tier 1	Group 2	RO Imp: 3.3	SRO Imp: 3.4
<CM 241821(1001)><<Knowledge of the interrelations between HIGH CONTAINMENT HYDROGEN CONCENTRATIONS the following: (CFR: 41.7 / 45.8)>> <CM 241824(1001)><<Containment Atmosphere Control System>>					

Learning Objective(s)

 [<OB 1537846\(1101\)><<Q27 500000 EK2.03 \(BL\)>>](#)
 User (Sys) ID N/A ([<OB 1537846\(1125\)><<1537846>>](#))

Cross Reference Links

Table: <TB 775424(1301)><<TRAINING - QUESTIONS - Track Questions Modified in this Project (CL-OPS-EXAM-ILT)>>
<TB 776084(1305)><<Tracking link in project CL-OPS-EXAM-ILT to source question 2151762>>

Question 28	ID: 2151813	Points: 1.00
-------------	-------------	--------------

<QQ 2151813(1410)><<The plant is operating at rated thermal power (RTP).

THEN, a transient occurred.

The sequence of events that followed are listed below:

Time	Event
0100	Multiple High DW Pressure alarms were received on 1H13-P601 AND 1H13-P680.
0115	RHR 'A' was placed in Containment Spray Mode.
0120	All Off-Site Power was lost (LOOP).
0121	4160V Bus 1A1 was re-energized by the Div 1 DG.

What actions are required to initiate RHR 'A' in the Low Pressure Coolant Injection Mode?>>

- A. <QQ 2151813(1480)><<Depress the CNMT SPRAY 'A' SEAL-IN RESET pushbutton ONLY.>>
- B. <QQ 2151813(1480)><<Manually start RHR 'A' Pump and then arm and depress the LPCS/LPCI FM RHR A MANUAL INITIATION pushbutton.>>
- C. <QQ 2151813(1480)><<Simultaneously depress the CNMT SPRAY 'A' DELAY TIMER RESET pushbutton and the CNMT SPRAY 'A' SEAL-IN RESET pushbutton, and then manually start RHR Pump 'A'.>>
- D. <QQ 2151813(1480)><<Simultaneously depress the CNMT SPRAY 'A' DELAY TIMER RESET pushbutton and the CNMT SPRAY 'A' SEAL-IN RESET pushbutton, then arm and depress the LPCS/LPCI FM RHR A MANUAL INITIATION pushbutton.>>

Answer	<QQ 2151813(1419)><<C>>
--------	-------------------------

Answer Explanation

<QQ 2151813(1412)><<C is correct:

Based on the conditions listed in the stem, RHR Pump 'A' was running with a containment spray signal locked in when 4160V Bus 1A1 was deenergized by the loss of off-site power.

Per CPS 5064.03 Alarm Panel 5064 Annunciators - Row 3, Annunciator 5064-3F RHR Pump A Auto Trip Operator Actions:

- A caution states that following a RHR Pump A(B) trip with a CNMT spray initiation signal present, the RHR pump breaker will not re-close on any further pump re-starts.
- RHR Pump Bkr is reset by simultaneously depressing the CNMT SPRAY A(B) DELAY TIMER RESET and CNMT SPRAY A(B) SEAL-IN RESET.
- Once the breaker is reset, the RHR pump can be manually restarted.

Incorrect Responses:

A is incorrect but plausible. This is the method used to transfer RHR from CS to LPCI under normal conditions per section 8.1.7 of CPS 3312.01 Residual Heat Removal (RHR). This method will not work here because of the undervoltage trip of RHR Pump 'A'.

B is incorrect but plausible because manual initiation of LPCI can normally be accomplished by manually starting RHR 'A' Pump. However, the stem conditions state that RHR 'A' was in Containment Spray mode when the pump tripped due to loss of power. Per CPS 3312.01 Residual Heat Removal, section 8.1.3, "Following a RHR Pump A(B) trip with a CNMT spray initiation signal present, the RHR pump breaker will NOT re-close on any further pump re-starts. RHR Pump Bkr is reset by simultaneously depressing: CNMT SPRAY A(B) DELAY TIMER RESET AND CNMT SPRAY A(B) SEAL-IN RESET."

D is incorrect but plausible because simultaneously depressing the CNMT SPRAY A(B) DELAY TIMER RESET and CNMT SPRAY A(B) SEAL-IN RESET will reset the RHR pump trip. However, the pump will still need to be manually started following the loss of AC power given in the stem.>>

Question Information

Topic	<QQ 2151813(1400)><<The plant is operating at rated thermal power (RTP). THEN, a transient occurred. The sequence>>				
User ID	<QQ 2151813(1404)><<CL-ILT-N19028>>		System ID	<QQ 2151813(1445)><<2151813>>	
Status	<QQ 2151813(1405)><<Active>>	Point Value	<QQ 2151813(1441)><<1.00>>	Time (min)	<QQ 2151813(1408)><<0>>

Open or Closed Reference	<QQ 2151813(1409)><<CLOSED>>
Operator Type_Cognitive Level	<QQ 2151813(1415)><<RO-HIGH>>
Operator Discipline	<QQ 2151813(1413)><<LO-I>>
10CFR55 Content	<TB 479395(1305)><<CFR: 41.10 Administrative, normal, abnormal, and emergency operating procedures for the facility.>>

References Provided	None
K/A Justification	Question meets the KA because the candidate must demonstrate knowledge of annunciator response procedure operator actions to start RHR 'A' in the LPCI mode following a 4160V 1A1 bus undervoltage.
SRO-Only Justification	N/A
Additional Information	Question is high cog written at the analysis & comprehension level. The candidate must analyze the conditions in the stem and then determine the impact on starting RHR 'A' in the LPCI mode

	following a 4160V 1A1 bus undervoltage (3-SPK).
--	---

NRC Exams Only			
Question Type	Bank (CL-ILT-N14004)	Difficulty	N/A
Technical Reference and Revision #	<ul style="list-style-type: none"> CPS 3312.01 Rev. 47d CPS 5064.03 (3F) Rev. 32a 		
Training Objective	203000.09 DISCUSS the effect: <ol style="list-style-type: none"> 1 A total loss or malfunction of the RESIDUAL HEAT REMOVAL System has on the plant. 2 A total loss or malfunction of various plant systems has on the RESIDUAL HEAT REMOVAL System. 		
Previous NRC Exam Use	ILT 14-1 NRC		

K/A Reference(s)

<CM 241999(1002)><<B2.4.31>>	Safety Function 5	Tier 3	Group	RO Imp: 4.2	SRO Imp: 4.1
<CM 241999(1001)><<Knowledge of annunciator alarms, indications, or response procedures. (CFR: 41.10 / 45.3)>>					
<CM 246497(1002)><<GS.203000>>	Safety Function 2	Tier 2	Group 1	RO Imp:	SRO Imp:
<CM 246497(1001)><<RHR/LPCI: Injection Mode (Plant Specific)>>					

Learning Objective(s)

 <OB 1537847(1101)><<Q28 203000 2.4.31 (BH)>>
 User (Sys) ID N/A (<OB 1537847(1125)><<1537847>>)

Cross Reference Links

None

Question 29	ID: 2153088	Points: 1.00
-------------	-------------	--------------

<QQ 2153088(1410)><<The plant is operating in MODE 3 with:

- Both Reactor Recirculation (RR) Pumps are running.
- Residual Heat Removal (RHR) Pump 'B' is operating in Shutdown Cooling (SDC) mode.

THEN, Div 2 Nuclear System Protection System (NSPS) Bus B power is lost.

Which ONE of the following describes a required operator action?>>

- A. <QQ 2153088(1480)><<Stop RHR Pump "B".>>
- B. <QQ 2153088(1480)><<Stop both RR pumps.>>
- C. <QQ 2153088(1480)><<Trip all running Reactor Water Cleanup (RT) pumps.>>
- D. <QQ 2153088(1480)><<Raise RPV water level above 44 inches Shutdown Range.>>

Answer	<QQ 2153088(1419)><<A>>
--------	-------------------------

Answer Explanation

<QQ 2153088(1412)><<A is correct.

Per CPS 5066.04 Alarm Panel 5066 Annunciators - Row 5, Annunciator 5066-4B 120V AC NSPS Logic B Power Failure:

- The loss of 120V AC NSPS Bus B power will cause a Group 3 Inboard Isolation.
- Group 3 inboard valves includes Shutdown Cooling Inboard Suction Isolation Valve (1E12-F009).

Per CPS 4006.01 Loss Of Shutdown Cooling:

- A loss of Div 2 NSPS power will disable the automatic pump trip related to 1E12-F009 not being fully open.
- Therefore, the operator must promptly stop the operating RHR pump (RHR 'B').

Incorrect Responses:

B is incorrect but plausible. This response would be correct if the Group 8 Component Cooling Water (CCW) containment isolation valves failed shut based on the conditions presented in the stem. A complete loss of CCW to Reactor Recirculation (RR) pumps would require both RR pumps to be stopped within 1 minute IAW CPS 3203.01 Component Cooling Water (CC). However, Group 8 containment isolation valves are not affected by a loss of Div 2 NSPS power.

C is incorrect but plausible. This response would be correct if NRHX outlet temperature instrument (1G33-N008) deenergized based on the conditions presented in the stem. A loss of power to 1G33-N008 initiates an isolation of the RWCU Outboard Valve (1G33-F004) IAW CPS 3509.01C001 Division 1 NSPS

Bus Outage Load Impact Matrix. A manual trip of running RWCU pumps would only be required if they did not trip automatically. However, since Div 2 NSPS power was lost, this is not a concern.

D is incorrect but plausible. This response would be correct if no forced reactor coolant circulation existed based on the conditions presented in the stem. No forced circulation requires maintaining RPV level greater than the minimum natural circulation level IAW CPS 4006.01 Loss of Shutdown cooling. However, with RR pumps running, this is not a concern.>>

Question Information

Topic	<QQ 2153088(1400)><<The plant is operating in MODE 3 with: Both Reactor Recirculation (RR) Pumps are running. Resid>>				
User ID	<QQ 2153088(1404)><<CL-ILT-N19029>>		System ID	<QQ 2153088(1445)><<2153088>>	
Status	<QQ 2153088(1405)><<Active>>	Point Value	<QQ 2153088(1441)><<1.00>>	Time (min)	<QQ 2153088(1408)><<0>>

Open or Closed Reference	<QQ 2153088(1409)><<CLOSED>>
Operator Type_Cognitive Level	<QQ 2153088(1415)><<RO-HIGH>>
Operator Discipline	<QQ 2153088(1413)><<LO-I>>
10CFR55 Content	<TB 479392(1305)><<CFR: 41.7 Design, components, and functions of control and safety systems, including instrumentation, signals, interlocks, failure modes, and automatic and manual features.>>

References Provided	None
K/A Justification	Question meets the KA because the candidate must demonstrate knowledge of the cause-effect relationship between AC electrical power (losing power to an NSPS bus) and RHR Shutdown Cooling.
SRO-Only Justification	N/A
Additional Information	Question is high cog written at the comprehension level. The candidate must recognize the interaction between systems (Div 2 NSPS and RHR-SDC mode) and the consequences of a loss of power (2-RI).

NRC Exams Only			
Question Type	New	Difficulty	N/A
Technical Reference and Revision #	<ul style="list-style-type: none"> CPS 3203.01 Rev. 37 CPS 3509.01C001 Rev. 11 		

	<ul style="list-style-type: none"> • CPS 3509.01C002 Rev. 13d • CPS 4006.01 Rev. 5d • CPS 5066.04 (4B) Rev. 27a • CPS 5000.01 (1C) Rev. 26a • CPS 5067.04 (4B) Rev. 31
Training Objective	<p>700004.09 Discus the effect:</p> <p>a. A total loss or malfunction of the NSPS System has on the plant.</p> <p>b. A total loss or malfunction of various plant systems has on the NSPS System.</p> <p>.1 Inverter Sync Loss</p> <p>.2 Inverter Fault</p> <p>.3 Loss of NSPS Bus</p> <p>.4 Loss of NSPS Solenoid Power</p>
Previous NRC Exam Use	None

K/A Reference(s)

<CM 236170(1002)><<205000.K1.06>>	Safety Function 4	Tier 2	Group 1	RO Imp: 3.2	SRO Imp: 3.3
<CM 236164(1001)><<Knowledge of the physical connections and/or cause-effect relationships between SHUTDOWN COOLING SYSTEM (RHR SHUTDOWN COOLING MODE) and the following: (CFR: 41.2 to 41.9 / 45.7 to 45.8)>> <CM 236170(1001)><<A.C. electrical power>>					

Learning Objective(s)

 <OB 1537848(1101)><<Q29 205000 K1.06 (NH)>>
 User (Sys) ID N/A (<OB 1537848(1125)><<1537848>>)

Cross Reference Links

None

Question 30	ID: 2151862	Points: 1.00
-------------	-------------	--------------

<QQ 2151862(1410)><<CPS is shutdown for a refueling outage.

THEN, Division 1 NSPS is de-energized due to a small fire.

What is the status of Low Pressure Core Spray (LPCS)?

LPCS will start:

1. Automatically.
2. By arming and depressing the LPCS/LPCI FM RHR A MANUAL INITIATION push-button.
3. By starting the LPCS Pump from the Main Control Room.>>

- A. <QQ 2151862(1480)><<1 ONLY>>
- B. <QQ 2151862(1480)><<2 ONLY>>
- C. <QQ 2151862(1480)><<3 ONLY>>
- D. <QQ 2151862(1480)><<1, 2, and 3>>

Answer	<QQ 2151862(1419)><<C>>
--------	-------------------------

Answer Explanation

<QQ 2151862(1412)><<C is correct.

Per CPS 3509.01C001 DIVISION 1 NSPS BUS (1C71-P001A) OUTAGE Appendix A, a loss of NSPS Div 1 bus will result in LPCS LOCA initiation logic, ATMs, and transmitters losing power and failing in the non-tripped positions. CPS 3313.01 section 8.1.4 Manual Initiation - Logic Not Operable directs starting the pump from the control switch in the MCR.

Incorrect responses:

A is incorrect but plausible. This answer is plausible because starting LPCS automatically would normally occur, but it will not work if the initiation logic is not operable.

B is incorrect but plausible. Starting LPCS by arming and depressing the LPCS/LPCI FM RHR A MANUAL INITIATION push-button is the normal method to manually initiate LPCS, but this will not work if the initiation logic is not operable.

D is incorrect but plausible. This answer is plausible because starting LPCS automatically and/or manually by arming and depressing the LPCS/LPCI FM RHR A MANUAL INITIATION push-button would normally occur, but it will not work if the initiation logic is not operable.>>

Question Information

Topic	<QQ 2151862(1400)><<CPS is shutdown for a refueling outage. THEN, Division 1 NSPS is de-energized due to a small fir>>				
User ID	<QQ 2151862(1404)><<CL-ILT-N19030>>		System ID	<QQ 2151862(1445)><<2151862>>	
Status	<QQ 2151862(1405)><<Active>>	Point Value	<QQ 2151862(1441)><<1.00>>	Time (min)	<QQ 2151862(1408)><<0>>

Open or Closed Reference	<QQ 2151862(1409)><<CLOSED>>
Operator Type_Cognitive Level	<QQ 2151862(1415)><<RO-HIGH>>
Operator Discipline	<QQ 2151862(1413)><<LO-I>>
10CFR55 Content	<TB 479385(1305)><<10 CFR 55.41 RO WRITTEN EXAMINATION>>

References Provided	None
K/A Justification	Question meets the KA because the candidate must demonstrate understanding of how a loss of Div 1 NSPS affects LPCS initiation logic.
SRO-Only Justification	N/A
Additional Information	Question is high cog written at the comprehension level. The candidate must recognize the interaction between NSPS and LPCS and then determine how significant the effect of a loss of NSPS is on the ability to initiate LPCS (2-RI).

NRC Exams Only			
Question Type	New	Difficulty	N/A
Technical Reference and Revision #	<ul style="list-style-type: none"> CPS 3509.01C001 Rev. 11 CPS 3313.01 Rev. 17e 		
Training Objective	209001.09 DISCUSS the effect: <ol style="list-style-type: none"> A total loss or malfunction of various plant systems has on the LPCS System. 		
Previous NRC Exam Use	None		

K/A Reference(s)

<CM 236485(1002)><<209001.K2.03>>	Safety Function 2	Tier 2	Group 1	RO Imp: 2.9*	SRO Imp: 3.1*
<CM 236482(1001)><<Knowledge of electrical power supplies to the following: (CFR: 41.7)>> <CM 236485(1001)><<Initiation logic>>					

Learning Objective(s)

 <OB 1537849(1101)><<Q30 209001 K2.03 (NH)>>
 User (Sys) ID N/A (<OB 1537849(1125)><<1537849>>)

Cross Reference Links

None

Question 31	ID: 2151882	Points: 1.00
-------------	-------------	--------------

<QQ 2151882(1410)><<CPS is operating at 85% Rated Thermal Power (RTP).

THEN, the MCR receives the following:

- Annunciator 5062-8E HPCS Out of Service is in alarm.
- HPCS Line Break Detected status lamp is lit.

Which of the following describes the status of the plant?>>

- A. <QQ 2151882(1480)><<HPCS Water Leg Pump has tripped.>>
- B. <QQ 2151882(1480)><<RT pumps trip on low suction pressure.>>
- C. <QQ 2151882(1480)><<SLC injection path to the RPV is compromised.>>
- D. <QQ 2151882(1480)><<Normal due to the head of water above the core plate at this power level.>>

Answer	<QQ 2151882(1419)><<C>>
--------	-------------------------

Answer Explanation

<QQ 2151882(1412)><<C is correct.

- Per CPS 3314.01V001 STANDBY LIQUID CONTROL VALVE LINEUP, SLC injection is normally through the HPCS sparger (1C41-F334), and the alternate path through the vessel bottom head connection valve (1C410F008) is locked closed.
- CPS M05-1074 HIGH PRESSURE CORE SPRAY and M05-1071 PID NUCLEAR BOILER show 1E31-N681 differential pressure device between the HPCS injection line and the interior of the reactor vessel above the core bottom plate.
- Per CPS 5062.08 ALARM PANEL 5062 ANNUNCIATORS - ROW 8, HPCS line break is detected when the differential pressure sensed at 1E31-N681 reaches -3.4 psid.

Conditions in the stem indicate that a HPCS line break has occurred. With the line break downstream of the HPCS injection line check valve, SLC injection will be compromised.

Incorrect Responses:

A is incorrect but plausible. A trip of the HPCS Water Leg Pump will affect system flow and differential pressure, but with the HPCS injection valve closed, will not affect the line break detection sensing.

B is incorrect but plausible. The RT pumps take suction from the bottom head drain line, near the HPCS line break detection sensing points. However, the RT pump trip occurs if the RT suction valves are not fully open or if inlet flow to the pump is less than 70 gpm for 60 seconds. Given the location of the pump

suction at the bottom of the core and reactor pressure at rated thermal power, a HPCS line break will not cause any of the above events in the RT system.

D is incorrect but plausible. Per CPS 3315.02 LEAK DETECTION (LD) section 2.2, these conditions may not clear until sufficient steaming rate is achieved and may require power and core flow to be >80%. Power given in the stem is 85%.>>

Question Information

Topic	<QQ 2151882(1400)><<CPS is operating at 85% Rated Thermal Power (RTP). THEN, the MCR receives the following: Annu>>				
User ID	<QQ 2151882(1404)><<CL-ILT-N19031>>			System ID	<QQ 2151882(1445)>><<2151882>>
Status	<QQ 2151882(1405)>><<Active>>	Point Value	<QQ 2151882(1441)>><<1.00>>	Time (min)	<QQ 2151882(1408)>><<0>>

Open or Closed Reference	<QQ 2151882(1409)><<CLOSED>>
Operator Type_Cognitive Level	<QQ 2151882(1415)><<RO-HIGH>>
Operator Discipline	<QQ 2151882(1413)><<LO-I>>
10CFR55 Content	<TB 479392(1305)><<CFR: 41.7 Design, components, and functions of control and safety systems, including instrumentation, signals, interlocks, failure modes, and automatic and manual features.>>

References Provided	None
K/A Justification	Question meets the KA because the candidate is given a HPCS malfunction in the stem and must determine its effect on the SLC system.
SRO-Only Justification	N/A
Additional Information	Question is high cog written at the comprehension level. The candidate must determine effect of HPCS system malfunction on SLC system (2-RI).

NRC Exams Only			
Question Type	Bank (CL-ILT-6029)	Difficulty	N/A
Technical Reference and Revision #	<ul style="list-style-type: none"> CPS 5062.08 (8E) Rev. 26c CPS 3315.02 Rev. 15a CPS 3314.01V001 Rev. 10a 		
Training Objective	209002.09 DISCUSS the effect: .1 A total loss or malfunction of the HIGH		

	<p>PRESSURE CORE SPRAY System has on the plant.</p> <p>.2 A total loss or malfunction of various plant systems has on the HIGH PRESSURE CORE SPRAY System.</p>
Previous NRC Exam Use	None

K/A Reference(s)

<CM 236594(1002)><<209002.K3.02>>	Safety Function 2	Tier 2	Group 1	RO Imp: 3.3	SRO Imp: 3.3
<CM 236592(1001)><<Knowledge of the effect that a loss or malfunction of the HIGH PRESSURE CORE SPRAY SYSTEM (HPCS) will have on following: (CFR: 41.7 / 45.4)>> <CM 236594(1001)><<Standby liquid control system: Plant-Specific>>					

Learning Objective(s)

 <OB 1537850(1101)><<Q31 209002 K3.02 (BH)>>
 User (Sys) ID N/A (<OB 1537850(1125)><<1537850>>)

Cross Reference Links

None

Question 32	ID: 2151902	Points: 1.00
-------------	-------------	--------------

<QQ 2151902(1410)><<Each Standby Liquid Control (SLC) pump is protected from overpressurization by a relief valve that discharges to the SLC _____.>>

- A. <QQ 2151902(1480)><<Test Tank>>
- B. <QQ 2151902(1480)><<Storage Tank>>
- C. <QQ 2151902(1480)><<Pump Suction Line>>
- D. <QQ 2151902(1480)><<Waste Water Storage Drum>>

Answer	<QQ 2151902(1419)><<C>>
--------	-------------------------

Answer Explanation

<QQ 2151902(1412)><<C is correct.

Per M05-1077 STANDBY LIQUID CONTROL, the SLC pump relief valve (1C41-F029A/B) discharges to the suction line of the associated pump.

Incorrect Responses:

A is incorrect but plausible. This tank is used for SLC surveillance and borated water is discharged to it, but the SLC pump relief valve does not.

B is incorrect but plausible. This is the suction source for SLC pumps, and various plant reliefs discharge back to their respective tanks, but the SLC pump relief valve does not.

D is incorrect but plausible. SLC water is drained to the SLC Waste Water Storage Drum during flushing, but the SLC pump relief valve does not.>>

Question Information

Topic	<QQ 2151902(1400)><<Each Standby Liquid Control (SLC) pump is protected from overpressurization by a relief valve that >>				
User ID	<QQ 2151902(1404)><<CL-ILT-N19032>>		System ID	<QQ 2151902(1445)>><<2151902>>	
Status	<QQ 2151902(1405)>><<Active>>	Point Value	<QQ 2151902(1441)>><<1.00>>	Time (min)	<QQ 2151902(1408)>><<0>>

Open or Closed Reference	<QQ 2151902(1409)><<CLOSED>>
Operator Type_Cognitive Level	<QQ 2151902(1415)><<RO-MEMORY>>
Operator Discipline	<QQ 2151902(1413)><<LO-I>>
10CFR55 Content	<TB 479392(1305)><<CFR: 41.7 Design, components, and functions of control and safety systems, including instrumentation, signals, interlocks, failure modes, and automatic and manual features.>>

References Provided	None
K/A Justification	Question meets the KA because the candidate must demonstrate knowledge of how the SLC system provides overpressure protection for the core by correctly selecting where the SLC relief valves discharge.
SRO-Only Justification	N/A
Additional Information	This is a low cog question written at the memory level. The candidate must recall facts about system components (1-F).

NRC Exams Only			
Question Type	New	Difficulty	N/A
Technical Reference and Revision #	<ul style="list-style-type: none"> M05-1077 Sheet 1 Rev. AC 		
Training Objective	211000.02 DESCRIBE the major flowpaths for the following modes of the STANDBY LIQUID CONTROL System operation. <ul style="list-style-type: none"> .1 Standby Lineup .2 Injection Flowpaths .3 Operability Flowpath .4 Flush Flowpath 		
Previous NRC Exam Use	None		

K/A Reference(s)

<CM 236685(1002)><<211000.K4.10>>	Safety Function 1	Tier 2	Group 1	RO Imp: 2.8	SRO Imp: 3.1
<CM 236675(1001)><<Knowledge of STANDBY LIQUID CONTROL SYSTEM design feature(s) and/or interlocks which provide for the following: (CFR: 41.7)>> <CM 236685(1001)><<Over pressure protection>>					

Learning Objective(s)

 <OB 1537851(1101)><<Q32 211000 K4.10 (NL)>>
 User (Sys) ID N/A (<OB 1537851(1125)><<1537851>>)

Cross Reference Links

None

Question 33	ID: 2152430	Points: 1.00
-------------	-------------	--------------

<QQ 2152430(1410)><<The plant is operating at rated thermal power (RTP).

THEN, a plant event occurs requiring the 'A' Reactor Operator to place the Reactor Mode Switch in SHUTDOWN.

Select the input that first scrams the reactor.>>

- A. <QQ 2152430(1480)><<Turbine Stop Valve (TSV) Closure>>
- B. <QQ 2152430(1480)><<Intermediate Range Monitor (IRM) Neutron High Flux>>
- C. <QQ 2152430(1480)><<Average Power Range Monitor (APRM) Setdown Flux High>>
- D. <QQ 2152430(1480)><<Reactor Mode Switch (RMS) in "SHUTDOWN">>

Answer	<QQ 2152430(1419)><<C>>
--------	-------------------------

Answer Explanation

<QQ 2152430(1412)><<C is correct.

In order to move the Reactor Mode Switch (RMS) from RUN to SHUTDOWN, the switch must move through START & HOT STBY (see graphic below).

Per CPS 3305.01 Reactor Protective System Appendix A, the APRM scram setpoint with the RMS in START & HOT STBY is 15%. Plant conditions given in the stem indicate reactor power is rated thermal power (RTP), therefore a scram occurs as soon as the RMS passes through START & HOT STBY.

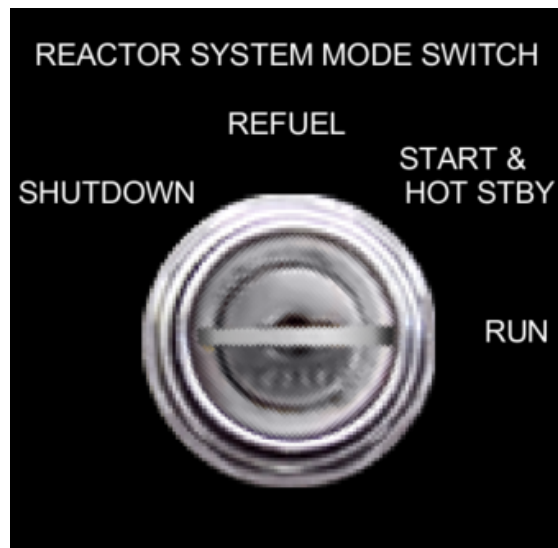

Incorrect responses:

A is incorrect but plausible. TSV closure causes a scram upon a trip of the main turbine. In this case, the scram will cause a main turbine trip, not vice versa.

B is incorrect but plausible. The IRM detectors are withdrawn from the core during a startup shortly after establishing Mode 1 conditions between 8 to 10% of rated thermal power. Detectors are inserted as a subsequent action after a scram or between 6 and 8% RTP. A scram signal will not be generated from IRMs under the conditions given.

D is incorrect but plausible. Although the RMS in "SHUTDOWN" generates a scram signal, it is not the first scram signal generated. The scram occurs as soon as the RMS passes through S/U HSB.>>

Question Information

Topic	<QQ 2152430(1400)><<The plant is operating at rated thermal power (RTP). THEN, a plant event occurs requiring the >>				
User ID	<QQ 2152430(1404)><<CL-ILT-N19033>>			System ID	<QQ 2152430(1445)>><<2152430>>
Status	<QQ 2152430(1405)>><<Active>>	Point Value	<QQ 2152430(1441)>><<1.00>>	Time (min)	<QQ 2152430(1408)>><<0>>

Open or Closed Reference	<QQ 2152430(1409)><<CLOSED>>
Operator Type_Cognitive Level	<QQ 2152430(1415)><<RO-MEMORY>>
Operator Discipline	<QQ 2152430(1413)><<LO-I>>
10CFR55 Content	<TB 479392(1305)><<CFR: 41.7 Design, components, and functions of control and safety systems, including instrumentation, signals, interlocks, failure modes, and automatic and manual features.>>

References Provided	None
K/A Justification	Question meets the KA because the candidate must demonstrate understanding of the scram signals generated by the RPS system and the mode switch configurations for those signals (e.g., RPS logic) to cause a reactor scram to determine the correct answer.
SRO-Only Justification	N/A
Additional Information	Question is low cog written at the memory level. The candidate must recall facts and information contained in a procedure (1-F).

NRC Exams Only			
Question Type	Bank (CL-ILT-0122)	Difficulty	N/A
Technical Reference and Revision #	<ul style="list-style-type: none"> CPS 3305.01 Rev. 12c 		
Training Objective	212000.03 DESCRIBE the function, operation, interlocks, trips, physical location, and power supplies of the following Reactor Protection System (RPS) and Alternate Rod Insertion (ARI) System components. <ul style="list-style-type: none"> .1 Backup Scram Valves .2 Scram Pilot Valve Valves .3 RPS 10-Second Delay (Function) .4 ARI 2-Minute Delay (Function) .5 Shorting Links .6 Scram Discharge Volume High Level Scram Bypass (Mode Switch Permissive) Interlock .7 NS4 Sensor Bypass Switches 		
Previous NRC Exam Use	None		

K/A Reference(s)

<CM 236810(1002)><<212000.K5.02>>	Safety Function 7	Tier 2	Group 1	RO Imp: 3.3	SRO Imp: 3.4
<CM 236808(1001)><<Knowledge of the operational implications of the following concepts as they apply to REACTOR PROTECTION SYSTEM : (CFR: 41.5 / 45.3)>> <CM 236810(1001)><<Specific logic arrangements>>					

Learning Objective(s)

 <OB 1537852(1101)><<Q33 212000 K5.02 (BL)>>
 User (Sys) ID N/A (<OB 1537852(1125)><<1537852>>)

Cross Reference Links

None

Question 34	ID: 2152437	Points: 1.00
-------------	-------------	--------------

<QQ 2152437(1410)><<The plant is performing a reactor startup.

- All Intermediate Range Monitors (IRMs) are on Range 2.

THEN, the High Voltage Power Supply input to the IRM 'E' detector lowers to 20 VDC.

This will cause an IRM 'E' ____ .>>

- A. <QQ 2152437(1480)><<INOP trip ONLY>>
- B. <QQ 2152437(1480)><<downscale indication ONLY>>
- C. <QQ 2152437(1480)><<INOP trip and downscale indication ONLY>>
- D. <QQ 2152437(1480)><<INOP trip, downscale indication and generate a rod block signal>>

Answer	<QQ 2152437(1419)><<D>>
--------	-------------------------

Answer Explanation

<QQ 2152437(1412)><<D is correct.

Per CPS 5004.02 Alarm Panel Annunciators - Row 2, RPS CH A IRM UPSC TRIP OR INOP, low IRM detector voltage results in a rod block which will preclude further rod movement. Normal voltage at the IRM High Voltage Power Supply per CPS 9431.14 INTERMEDIATE RANGE MONITOR (IRM) C51-K601A (B-H) CHANNEL CALIBRATION is > 125 VDC.

Incorrect responses:

A is incorrect but plausible. While the low voltage does cause the IRM instrument to be have an INOP trip, this is not the only result.

B is incorrect but plausible. While the low voltage does cause the IRM to read downscale, this is not the only result.

C is incorrect but plausible. This answer would be correct if the INOP condition did not cause a rod block as well.>>

Question Information

Topic	<QQ 2152437(1400)><<The plant is performing a reactor startup. All Intermediate Range Monitors (IRMs) are on Range 2. >>				
User ID	<QQ 2152437(1404)><<CL-ILT-N19034>>			System ID	<QQ 2152437(1445)><<2152437>>
Status	<QQ 2152437(1405)><<Active>>	Point Value	<QQ 2152437(1441)><<1.00>>	Time (min)	<QQ 2152437(1408)><<0>>

Open or Closed Reference	<QQ 2152437(1409)><<CLOSED>>
Operator Type_Cognitive Level	<QQ 2152437(1415)><<RO-MEMORY>>
Operator Discipline	<QQ 2152437(1413)><<LO-I>>
10CFR55 Content	<TB 479391(1305)><<CFR: 41.6 Design, components, and functions of reactivity control mechanisms and instrumentation.>>

References Provided	None
K/A Justification	Question meets the KA because the candidate must demonstrate understanding of how a failure of an IRM detector will affect the IRM system.
SRO-Only Justification	N/A
Additional Information	Question is low cog written at the memory level. The candidate must recall facts and information contained in a procedure (1-F).

NRC Exams Only			
Question Type	New	Difficulty	N/A
Technical Reference and Revision #	<ul style="list-style-type: none"> • CPS 5004.02 Rev. 29e • CPS 9431.14 Rev. 44h • CPS 3305.01 Rev. 12c • CPS 9031.14 Rev. 31a 		
Training Objective	215003.09 DISCUSS the effect: A total loss or malfunction of the IRM Systems has on the plant. A total loss or malfunction of various plant systems has on the IRM System. <ol style="list-style-type: none"> .1 IRM Detector stuck in the core during reactor startup .2 IRM failed upscale or downscale during reactor startup or shutdown .3 Power supply degradation .4 Faulty or erratic operation of detector or monitor 		

	.5 Faulty range switch .6 Failed recorder
Previous NRC Exam Use	None

K/A Reference(s)

<CM 237028(1002)><<215003.K6.04>>	Safety Function 7	Tier 2	Group 1	RO Imp: 3.0	SRO Imp: 3.0
<CM 237024(1001)><<Knowledge of the effect that a loss or malfunction of the following will have on the INTERMEDIATE RANGE MONITOR (IRM) SYSTEM : (CFR: 41.7 / 45.7)>> <CM 237028(1001)><<Detectors>>					

Learning Objective(s)

 <OB 1537853(1101)><<Q34 215003 K6.04 (NL)>>
 User (Sys) ID N/A (<OB 1537853(1125)><<1537853>>)

Cross Reference Links

None

Question 35	ID: 2152476	Points: 1.00
-------------	-------------	--------------

<QQ 2152476(1410)><<A reactor startup is in progress.

THEN, annunciator 5006-2H ROD OUT BLOCK is received.

- Source Range Monitor (SRM) channel 'B' is reading 95 counts per second (cps).
- All other SRM channels are reading between 5x10⁴ cps and 8x10⁴ cps.
- Only SRM detector 'A' is full in.
- Intermediate range (IRM) channel 'B' is on range 2.
- All other IRM channels are on range 3.

What is the cause of the rod block?>>

- A. <QQ 2152476(1480)><<SRM upscale>>
- B. <QQ 2152476(1480)><<SRM downscale>>
- C. <QQ 2152476(1480)><<SRM channel inoperable>>
- D. <QQ 2152476(1480)><<SRM detector retract not permitted>>

Answer	<QQ 2152476(1419)><<D>>
--------	-------------------------

Answer Explanation

<QQ 2152476(1412)><<D is correct.

Per CPS 3306.01 Source/Intermediate Range Monitors (SRM/IRM) step 2.7, SRMs provide inputs to the Rod Control and Information System (RCIS) which will produce a rod block due to: (Bypassed if the associated SRM channel is bypassed, or if both IRM channels associated with their respective divisional SRM channel are on range 8 or above.)

- SRM Inoperative (INOP)
- SRM Downscale at 3 cps (Rod block bypassed when IRMs associated with that divisional SRM channel are on range 3 or above.)
- SRM Upscale at 1 x 10⁵ cps
- SRM detector not full-in and < 100 cps (Rod block bypassed when IRMs associated with that divisional SRM channel are on range 3 or above.)

With SRM 'B' detector not full-in and reading < 100 cps, and with IRM 'B' on range 2, a rod block will occur as a result of the retract permissive interlock.

Incorrect responses:

A is incorrect but plausible. An SRM upscale of 1 x 10⁵ cps will cause a rod block, but none of the SRMs

have reached that value yet.

B is incorrect but plausible. An SRM downscale will cause a rod block, but none of the SRMs have reached that value yet.

C is incorrect but plausible. An inoperable SRM channel (SRM channel switch is not in OPERATE, or any module in the SRM drawer is unplugged, or HVPS low voltage) will result in a rod block, but there are no parameters in the stem that support that diagnosis.>>

Question Information

Topic	<QQ 2152476(1400)><<A reactor startup is in progress. THEN, annunciator 5006-2H ROD OUT BLOCK is received. Sour>>				
User ID	<QQ 2152476(1404)><<CL-ILT-N19035>>			System ID	<QQ 2152476(1445)><<2152476>>
Status	<QQ 2152476(1405)><<Active>>	Point Value	<QQ 2152476(1441)><<1.00>>	Time (min)	<QQ 2152476(1408)><<0>>

Open or Closed Reference	<QQ 2152476(1409)><<CLOSED>>
Operator Type_Cognitive Level	<QQ 2152476(1415)><<RO-HIGH>>
Operator Discipline	<QQ 2152476(1413)><<LO-I>>
10CFR55 Content	<TB 479392(1305)><<CFR: 41.7 Design, components, and functions of control and safety systems, including instrumentation, signals, interlocks, failure modes, and automatic and manual features.>>

References Provided	None
K/A Justification	Question meets the KA because the candidate must review the conditions in the stem and determine which SRM parameter changes resulted in the alarm given.
SRO-Only Justification	N/A
Additional Information	Question is high cog, written at the analysis and comprehension level. The candidate must review several discreet bits of information and recall knowledge of the SRM system to correctly determine the cause of the rod block (3-SPK).

NRC Exams Only			
Question Type	Bank (CL-ILT-A11005)	Difficulty	N/A
Technical Reference and Revision #	<ul style="list-style-type: none"> CPS 3306.01 Rev. 12c CPS 5006.02 (2H) Rev. 28d 		

Training Objective	215004.05 Discuss the Source Range Monitor System automatic functions/interlocks including purpose, signals, set points, sensing points, when bypassed, how/when they are. .1 SRM Upscale .2 High Trip .3 Downscale .4 Inoperative .5 Retract Not Permitted .6 SRM Detector Not Full In
Previous NRC Exam Use	None

K/A Reference(s)

<CM 237040(1002)><<215004.A1.06>>	Safety Function 7	Tier 2	Group 1	RO Imp: 3.1	SRO Imp: 3.1
<CM 237034(1001)><<Ability to predict and/or monitor changes in parameters associated with operating the SOURCE RANGE MONITOR (SRM) SYSTEM controls including: (CFR: 41.5 / 45.5)>> <CM 237040(1001)><<Lights and alarms>>					

Learning Objective(s)

 <OB 1537854(1101)><<Q35 215004 A1.06 (BH)>>
 User (Sys) ID N/A (<OB 1537854(1125)><<1537854>>)

Cross Reference Links

None

Question 36	ID: 2152507	Points: 1.00
-------------	-------------	--------------

<QQ 2152507(1410)><<The Source Range Monitoring (SRM) system will generate a Reactor Protection System (RPS) scram signal under what minimum set of conditions?

Shorting links ____ (1) ____ with an upscale trip on ____ (2) ____ channel(s).>>

- A. <QQ 2152507(1480)><<(1) REMOVED
(2) 1>>
- B. <QQ 2152507(1480)><<(1) INSTALLED
(2) 1>>
- C. <QQ 2152507(1480)><<(1) REMOVED
(2) 2>>
- D. <QQ 2152507(1480)><<(1) INSTALLED
(2) 2>>

Answer	<QQ 2152507(1419)><<A>>
--------	-------------------------

Answer Explanation

<QQ 2152507(1412)><<A is correct.

Per CPS 3306.01 SOURCE/INTERMEDIATE RANGE MONITORS (SRM/IRM) section 2.3, the SRM system provides two trip inputs to the Reactor Protection System (RPS): the SRM Channel Upscale Trip (2 x 105 cps) and the Inoperative Trip, (only if shorting links are removed and the SRM channel is not bypassed). Section 2.6 states that with the shorting links removed, the entire neutron monitoring system is placed in a non-coincidence mode of operation.

Incorrect responses:

B is incorrect but plausible. Plausible misconception that SRM provided inputs to RPS with the shorting links installed. With the shorting links installed, SRM provides no trip signals to RPS and the entire neutron monitoring system operates in a 2/4 coincidence mode.

C is incorrect but plausible. These conditions would result in a scram signal, but this is not the minimum required number of channels. This answer would be correct if the SRM system operated in coincidence mode with the shorting links removed.

D is incorrect but plausible. Plausible misconception that SRM provided inputs to RPS with the shorting links installed, and plausible misconception that SRM inputs to RPS operate in coincidence mode with the shorting links installed. With the shorting links installed, SRM provides no trip signals to RPS and the entire neutron monitoring system operates in a 2/4 coincidence mode.>>

Question Information

Topic	<QQ 2152507(1400)><<The Source Range Monitoring (SRM) system will generate a Reactor Protection System (RPS) scram sign>>				
User ID	<QQ 2152507(1404)><<CL-ILT-N19036>>		System ID	<QQ 2152507(1445)>><<2152507>>	
Status	<QQ 2152507(1405)>><<Active>>	Point Value	<QQ 2152507(1441)>><<1.00>>	Time (min)	<QQ 2152507(1408)>><<0>>

Open or Closed Reference	<QQ 2152507(1409)><<CLOSED>>
Operator Type_Cognitive Level	<QQ 2152507(1415)><<RO-MEMORY>>
Operator Discipline	<QQ 2152507(1413)><<LO-I>>
10CFR55 Content	<TB 479392(1305)><<CFR: 41.7 Design, components, and functions of control and safety systems, including instrumentation, signals, interlocks, failure modes, and automatic and manual features.>>

References Provided	None
K/A Justification	Question meets the KA because the candidate must demonstrate understanding of SRM inputs to the RPS system under various conditions.
SRO-Only Justification	N/A
Additional Information	Question is low cog written at the memory level. The candidate must recall facts and information contained in a procedure (1-F).

NRC Exams Only			
Question Type	Bank (CL-ILT-6351)	Difficulty	N/A
Technical Reference and Revision #	CPS 3306.01 Rev. 12c		
Training Objective	215004.08 Given the Source Range Monitor System, DESCRIBE the systems supported and the nature of the support. .2 Reactor Protective System (RPS)		
Previous NRC Exam Use	None		

K/A Reference(s)

<CM 237062(1002)><<215004.K1.01>>	Safety Function 7	Tier 2	Group 1	RO Imp: 3.6	SRO Imp: 3.7
<CM 237061(1001)><<Knowledge of the physical connections and/or causeeffect relationships between SOURCE RANGE MONITOR (SRM) SYSTEM and the following: (CFR: 41.2 to 41.9 / 45.7 to 45.8)>> <CM 237062(1001)><<Reactor protection system>>					

Learning Objective(s)

 <OB 1537855(1101)><<Q36 215004 K1.01 (BL)>>
 User (Sys) ID N/A (<OB 1537855(1125)><<1537855>>)

Cross Reference Links

None

Question 37	ID: 2155202	Points: 1.00
-------------	-------------	--------------

<QQ 2155202(1410)><<CPS is operating at rated thermal power.

- Average Power Range Monitoring System (APRM) channel 'C' level D has all but one Local Power Range Monitoring (LPRM) input bypassed due to detector faults.
- All other LPRMs are working properly.
- No other operator actions have been taken.

THEN, the channel 'A' APRM power supply fails.

What actions, if any, are necessary to mitigate the plant impact?>>

- A. <QQ 2155202(1480)><<No action is required.>>
- B. <QQ 2155202(1480)><<Perform immediate actions of CPS 4100.01, Reactor Scram.>>
- C. <QQ 2155202(1480)><<Place the Division 1 Sensor Bypass Switch to the BYPASS position ONLY.>>
- D. <QQ 2155202(1480)><<Place the Division 1 Sensor Bypass Switch to the BYPASS position and depress 4 Scram RESET push-buttons.>>

Answer	<QQ 2155202(1419)><<C>>
--------	-------------------------

Answer Explanation

<QQ 2155202(1412)><<C is correct.

Per CPS 5004.01 ALARM PANEL ANNUNCIATORS - ROW 1, APRM A UPSC TRIP OR INOP, low voltage to the power supply of the APRM causes an INOP annunciator for that channel and will generate a rod withdrawal block. Although APRM channel 'C' is inoperable per ITS, having less than two operable LPRM inputs per level will not activate an APRM INOP trip per CPS 3308.01 LOCAL/AVG POWER RANGE MONITORS (L/APRM), section 6.3. The required action to mitigate the rod withdrawal block is to bypass the 'A' APRM by placing the Division 1 Sensor Bypass control switch to BYPASS per CPS 3305.01 REACTOR PROTECTIVE SYSTEM.

Incorrect responses:

A is incorrect but plausible misconception that the low input voltage to the 'A' APRM channel will not cause it to become inoperable and/or generate a rod block.

B is incorrect but plausible because two APRM INOP signals will cause a reactor scram per CPS 5004.01(1H). The conditions in stem indicate less than 2 operable inputs per level on APRM channel 'C' as well as APRM channel 'A' inoperable due to low input voltage; however, CPS 3308.01 states that less than two operable LPRM inputs per level will not activate an APRM INOP trip.

D is incorrect but is a plausible misconception that the stem conditions will result in a half scram. Placing the Division 1 Sensor Bypass Switch to the BYPASS position and resetting the scram per CPS 3305.01 is correct response if a half scram were to occur.>>

Question Information

Topic	<QQ 2155202(1400)><<CPS is operating at rated thermal power. Average Power Range Monitoring System (APRM) channel 'C'>>				
User ID	<QQ 2155202(1404)><<CL-ILT-N19037>>			System ID	<QQ 2155202(1445)><<2155202>>
Status	<QQ 2155202(1405)><<Active>>	Point Value	<QQ 2155202(1441)><<1.00>>	Time (min)	<QQ 2155202(1408)><<0>>

Open or Closed Reference	<QQ 2155202(1409)><<CLOSED>>
Operator Type_Cognitive Level	<QQ 2155202(1415)><<RO-HIGH>>
Operator Discipline	<QQ 2155202(1413)><<LO-I>>
10CFR55 Content	<TB 479392(1305)><<CFR: 41.7 Design, components, and functions of control and safety systems, including instrumentation, signals, interlocks, failure modes, and automatic and manual features.>>

References Provided	None
K/A Justification	Question meets the A2(b) portion of the KA because the candidate must demonstrate the use procedures to mitigate the impact of having an inoperative trip on the APRM system. As permitted by ES-401 D.2.a, the (a) portion of the K/A (the low cog portion) is not tested.
SRO-Only Justification	N/A
Additional Information	Question is high cog written at the analysis and comprehension level. The candidate must determine based on the conditions given in the stem that one APRM channel has an INOP trip and then determine how to mitigate the condition (3-SPK).

NRC Exams Only			
Question Type	New	Difficulty	N/A
Technical Reference and Revision #	<ul style="list-style-type: none"> CPS 5004.01 Rev. 28d CPS 3308.01 Rev. 11f CPS 3305.01 Rev 12c 		
Training Objective	215005.09 DISCUSS the effect: a. a total loss or malfunction of the AVERAGE		

	POWER RANGE MONITOR System has on the plant.
Previous NRC Exam Use	None

K/A Reference(s)

<CM 237108(1002)><<215005.A2.03>>	Safety Function 7	Tier 2	Group 1	RO Imp: 3.6	SRO Imp: 3.8
<CM 237105(1001)><<Ability to (a) predict the impacts of the following on the AVERAGE POWER RANGE MONITOR/LOCAL POWER RANGE MONITOR SYSTEM ; and (b) based on those predictions, use procedures to correct, control, or mitigate the consequences of those abnormal conditions or operations: (CFR: 41.5 / 45.6)>> <CM 237108(1001)><<Inoperative trip (all causes)>>					

Learning Objective(s)

 <OB 1537856(1101)><<Q37 215005 A2.03 (NH)>>
 User (Sys) ID N/A (<OB 1537856(1125)><<1537856>>)

Cross Reference Links

Table: <TB 775424(1301)><<TRAINING - QUESTIONS - Track Questions Modified in this Project (CL-OPS-EXAM-ILT)>>
<TB 776324(1305)><<Tracking link in project CL-OPS-EXAM-ILT to source question 2152555>>

Question 38	ID: 2152762	Points: 1.00
-------------	-------------	--------------

<QQ 2152762(1410)><<The reactor is operating at 65% power and 75% of rated flow.
THEN, the APRM Channel 'A' flow signal from the Recirculation System Flow Converter fails to 15% flow.

What is the status of the APRM 'A' Thermal rod block and scram trip units?

	APRM 'A' Thermal Upscale Rod Block Channel Status (RCIS)	APRM 'A' Thermal Scram Trip Channel Status (RPS)
Choice 1	NOT tripped	NOT tripped
Choice 2	Tripped	Tripped
Choice 3	Tripped	NOT tripped
Choice 4	NOT tripped	Tripped

>>

- A. <QQ 2152762(1480)><<Choice 1>>
- B. <QQ 2152762(1480)><<Choice 2>>
- C. <QQ 2152762(1480)><<Choice 3>>
- D. <QQ 2152762(1480)><<Choice 4>>

Answer	<QQ 2152762(1419)><>
--------	-------------------------

Answer Explanation

<QQ 2152762(1412)><<B is correct.

Per CPS 5004.01 ALARM PANEL 5004 ANNUNCIATORS - ROW 1, Flow Biased Upscale Rod Block is calculated using the following formula:

- Rod Block Setpoint = 0.58W + 50% with a maximum of ≤ 108.0% of RATED THERMAL POWER. With W (loop flow) at 15% due to the flow converter failure, the rod block trip setpoint is 58.7% which is below the actual power level provided in the stem (65%).

Per CPS 3305.01 REACTOR PROTECTIVE SYSTEM Appendix A, the thermal upscale trip setpoint is determined using the following formula:

- RPS Trip Setpoint = 0.58W + 56% during two RR loop operation, 111% max. With W (loop flow) at 15% due to the flow converter failure, the trip setpoint is 64.7% which is below the actual power level provided in the stem (65%).

Incorrect responses:

A is incorrect but plausible because actual system flow is unaffected by the Flow Converter failure, and if the trip setpoints are recalled or calculated incorrectly.

C is incorrect but plausible. The first part is correct. It is plausible that receipt of a single downscale signal failure resulted in a rod block but not an RPS signal since RPS trip logic is 2 out of 4 logic. A scram will not occur for the conditions given in the stem; however, the single scram signal will still be processed by the RPS system.

D is incorrect but plausible because of the misconception that a Thermal Upscale Rod Block will not occur for the given circumstances.>>

Question Information

Topic	<QQ 2152762(1400)><<The reactor is operating at 65% power and 75% of rated flow. THEN, the APRM Channel 'A' flow s>>				
User ID	<QQ 2152762(1404)><<CL-ILT-N19038>>			System ID	<QQ 2152762(1445)>><<2152762>>
Status	<QQ 2152762(1405)>><<Active>>	Point Value	<QQ 2152762(1441)>><<1.00>>	Time (min)	<QQ 2152762(1408)>><<0>>

Open or Closed Reference	<QQ 2152762(1409)><<CLOSED>>
Operator Type_Cognitive Level	<QQ 2152762(1415)><<RO-HIGH>>
Operator Discipline	<QQ 2152762(1413)><<LO-I>>
10CFR55 Content	<TB 479392(1305)><<CFR: 41.7 Design, components, and functions of control and safety systems, including instrumentation, signals, interlocks, failure modes, and automatic and manual features.>>

References Provided	None
K/A Justification	Question meets the KA because the candidate must demonstrate knowledge of how a failure in the thermal trip signal from the APRM will affect the RPS trip circuitry.
SRO-Only Justification	N/A
Additional Information	Question is high cog written at the analysis and comprehension level. The candidate must calculate rod block and RPS scram trip setpoints using the given flow condition and then determine how the RCIS and RPS systems will respond (3-PEO).

NRC Exams Only			
Question Type	Bank (CL-ILT-N15038)	Difficulty	N/A
Technical Reference and Revision #	<ul style="list-style-type: none"> CPS 5004.01 (1K) Rev. 28d CPS 3305.01 Rev. 12c 		
Training Objective	215005.09 DISCUSS the effect: a. a total loss or malfunction of the AVERAGE POWER RANGE MONITOR System has on the plant.		
Previous NRC Exam Use	ILT 15-1 NRC		

K/A Reference(s)

<CM 237153(1002)><<215005.K3.01>>	Safety Function 7	Tier 2	Group 1	RO Imp: 4.0	SRO Imp: 4.0
<CM 237152(1001)><<Knowledge of the effect that a loss or malfunction of the AVERAGE POWER RANGE MONITOR/LOCAL POWER RANGE MONITOR SYSTEM will have on following: (CFR: 41.7 / 45.4)>> <CM 237153(1001)><<RPS>>					

Learning Objective(s)

 <OB 1537857(1101)><<Q38 215005 K3.01 (BH)>>
 User (Sys) ID N/A (<OB 1537857(1125)><<1537857>>)

Cross Reference Links

None

Question 39	ID: 2152604	Points: 1.00
-------------	-------------	--------------

<QQ 2152604(1410)><<The plant is operating at rated thermal power (RTP).

THEN, Reactor Core Isolation Cooling (RCIC) automatically initiates due to a plant transient.

The following is noted on 1H13-P601:



Which of the following valves is OPEN?>>

- A. <QQ 2152604(1480)><<RCIC Turbine Trip Vlv (1E51-C002E)>>
- B. <QQ 2152604(1480)><<RCIC Turb Stm Supp Shutoff Valve (1E51-F045)>>
- C. <QQ 2152604(1480)><<RHR & RCIC Stm Supp Outbd Isol Valve (1E51-F064)>>
- D. <QQ 2152604(1480)><<RCIC Pmp Min Flow Recirc to Suppr Pool (1E51-F019)>>

Answer	<QQ 2152604(1419)><>
--------	-------------------------

Answer Explanation

<QQ 2152604(1412)><<B is correct.

The red light above the RCIC DIV 1 ISOLATION RESET keylock switch is indicative of a Group 6 isolation signal. Per CPS 4001.01C001 AUTOMATIC ISOLATION CHECKLIST, 1E51-F064 shuts on a Group 6 isolation signal. CPS 5063.05 ALARM PANEL 5063 ANNUNCIATORS - ROW 5 (5B) RCIC TURBINE TRIPPED states that isolation of RCIC will cause a RCIC turbine trip valve closure (1E51-C002E). Per CPS 3310.01 REACTOR CORE ISOLATION COOLING, the RCIC turbine trip also causes

1E51-F019 to shut. The only automatic action that causes 1E51-F045 to shut is an RPV high level shutdown at Level 8.

Incorrect responses:

A is incorrect but plausible. This answer would be correct if the Group 6 isolation indication given in the stem did not cause an isolation of the RCIC system.

C is incorrect but plausible. This answer would be correct if a Group 5 isolation had been indicated by the stem.

D is incorrect but plausible. This answer would be correct if the RCIC minimum flow valve remained open during an isolation signal. This answer is plausible because minimum flow valves typically open when the associated pump is not injecting to the core.>>

Question Information

Topic	<QQ 2152604(1400)><<The plant is operating at rated thermal power (RTP). THEN, Reactor Core Isolation Cooling (RCIC)>>				
User ID	<QQ 2152604(1404)><<CL-ILT-N19039>>			System ID	<QQ 2152604(1445)>><<2152604>>
Status	<QQ 2152604(1405)>><<Active>>	Point Value	<QQ 2152604(1441)>><<1.00>>	Time (min)	<QQ 2152604(1408)>><<0>>

Open or Closed Reference	<QQ 2152604(1409)><<CLOSED>>
Operator Type_Cognitive Level	<QQ 2152604(1415)><<RO-HIGH>>
Operator Discipline	<QQ 2152604(1413)><<LO-I>>
10CFR55 Content	<TB 479392(1305)><<CFR: 41.7 Design, components, and functions of control and safety systems, including instrumentation, signals, interlocks, failure modes, and automatic and manual features.>>

References Provided	None
K/A Justification	Question meets the KA because the candidate must demonstrate understanding of RCIC valve automatic operations to answer the question.
SRO-Only Justification	N/A
Additional Information	Question is high cog written at the analysis and comprehension level. The candidate must interpret the stem conditions and recognize that an CRVICS isolation has occurred and then determine how the RCIC system has been affected (2-RI).

NRC Exams Only			
Question Type	New	Difficulty	N/A
Technical Reference and Revision #	<ul style="list-style-type: none"> • CPS 4001.02C001 Rev. 16c • N-CL-OPS-217000 Rev. 7 • CPS 5063.05 (5B) Rev. 33d • CPS 3310.01 Rev. 31c 		
Training Objective	217000.03 DESCRIBE the function, operation, interlocks, trips, physical location, and power supplies of the following REACTOR CORE ISOLATION COOLING System components. <ul style="list-style-type: none"> .1 Steam Supply Shutoff Valve .2 Turbine Trip Throttle Valve .3 Exhaust Line Rupture Discs .4 Exhaust Vacuum Breakers .5 Exhaust Vacuum Breaker line Isolation Valves .6 Pump Suction Valves .7 Min Flow Valve .8 Water Leg Pump .9 Gland Seal Air Compressor .10 Lube Oil System .11 RCIC Room Cooling System .12 Ramp Generator 		
Previous NRC Exam Use	None		

K/A Reference(s)

<CM 237338(1002)><<217000.A3.01>>	Safety Function 2	Tier 2	Group 1	RO Imp: 3.5	SRO Imp: 3.5
<CM 237337(1001)><<Ability to monitor automatic operations of the REACTOR CORE ISOLATION COOLING SYSTEM (RCIC) including: (CFR: 41.7 / 45.7)>> <CM 237338(1001)><<Valve operation>>					

Learning Objective(s)

 <OB 1537858(1101)><<Q39 217000 A3.01 (NH)>>
 User (Sys) ID N/A (<OB 1537858(1125)><<1537858>>)

Cross Reference Links

None

Question 40	ID: 2155049	Points: 1.00
-------------	-------------	--------------

<QQ 2155049(1410)><<Which of the following alarms identifies a condition that could prevent a Reactor Core Isolation Cooling (RCIC) manual initiation?>>

- A. <QQ 2155049(1480)><<5063-5D, RCIC TURBINE BRG OIL PRESS LOW>>
- B. <QQ 2155049(1480)><<5063-7D, RCIC WATER LEG PUMP AUTO TRIP>>
- C. <QQ 2155049(1480)><<5063-4E, RCIC COMPRESSOR AUTO START FAILURE>>
- D. <QQ 2155049(1480)><<5063-3B, RCIC DIV 1 TURB EXH DIAPH PRESSURE HIGH>>

Answer	<QQ 2155049(1419)><<D>>
--------	-------------------------

Answer Explanation

<QQ 2155049(1412)><<D is correct:

Per CPS 5063.03 Alarm Panel 5063 Annunciators - Row 3 (3C), a Group 6 isolation will occur upon RCIC turbine diaphragm pressure exceeding the alarm setpoint. The Group 6 isolation will shut both 1E51-F031, RCIC Suppression Pool Suction Valve and 1E51-F064, RHR & RCIC Steam Supply Outboard Isolation Valve, rendering the RCIC system unable to be manually initiated. This annunciator is actuated by 1 of 2 diaphragm pressure instruments exceeding the alarm setpoint; 2 of 2 coincidence is required to cause the isolation.

Incorrect Responses:

A is incorrect but plausible because the RCIC turbine should not be operated with low oil pressure. Per CPS 5063.05 Alarm Panel 5063 Annunciators - Row 5 (5D), this condition could result in RCIC turbine seizure. However, it is still possible to manually initiate RCIC with this condition present.

B is incorrect but plausible because other ECCS system water leg pump failures (RHR) may prevent the system from operating properly. However, per CPS 5063.03 Alarm Panel 5063 Annunciators - Row 7 (7D), as long as the water leg pump is not running, and RCIC storage tank level remains about 327 inches and has not changed, and no RCIC system valves have repositioned, then the RCIC piping on the pump discharge is sufficiently filled, allowing RCIC for use.

C is incorrect but plausible because RCIC should not be operated with a RCIC Gland Seal Air Compressor failure. Per CPS 5063.04 Alarm Panel 5063 Annunciators - Row 4 (4E), if RCIC is not required for safe plant shutdown, shutdown the RCIC turbine. However, it is still possible to manually initiate RCIC with this condition present.>>

Question Information

Topic	<QQ 2155049(1400)><<Which of the following alarms identifies a condition that could prevent a Reactor Core Isolation Co>>				
User ID	<QQ 2155049(1404)><<CL-ILT-N19040>>		System ID	<QQ 2155049(1445)><<2155049>>	
Status	<QQ 2155049(1405)><<Active>>	Point Value	<QQ 2155049(1441)><<1.00>>	Time (min)	<QQ 2155049(1408)><<0>>

Open or Closed Reference	<QQ 2155049(1409)><<CLOSED>>
Operator Type_Cognitive Level	<QQ 2155049(1415)><<RO-MEMORY>>
Operator Discipline	<QQ 2155049(1413)><<LO-I>>
10CFR55 Content	<TB 479395(1305)><<CFR: 41.10 Administrative, normal, abnormal, and emergency operating procedures for the facility.>>

References Provided	None
K/A Justification	Question meets the KA because the candidate must demonstrate knowledge of RCIC interlocks which will prevent and allow manual initiation to correctly answer the question.
SRO-Only Justification	N/A
Additional Information	Question is low cog written at the memory level. The candidate must recall facts and information contained in a procedure (1-F).

NRC Exams Only			
Question Type	New	Difficulty	N/A
Technical Reference and Revision #	<ul style="list-style-type: none"> • CPS 5063.03 (3B) Rev. 34 • CPS 5063.04 (4E) Rev. 31c • CPS 5063.05 (5D) Rev. 33d • CPS 5063.07 (7D) Rev. 31 		
Training Objective	217000.15 Given REACTOR CORE ISOLATION COOLING (RI) System initial conditions, PREDICT how the system and/or plant parameters will respond to the manipulation of the following controls. .1 Depressing Manual Initiation Pushbutton		
Previous NRC Exam Use	None		

K/A Reference(s)

<CM 237381(1002)><<217000.K4.06>>	Safety Function 2	Tier 2	Group 1	RO Imp: 3.5	SRO Imp: 3.5
<CM 237375(1001)><<Knowledge of REACTOR CORE ISOLATION COOLING SYSTEM (RCIC) design feature(s) and/or interlocks which provide for the following: (CFR: 41.7)>> <CM 237381(1001)><<Manual initiation>>					

Learning Objective(s)

 <OB 1537859(1101)><<Q40 217000 K4.06 (NL)>>
 User (Sys) ID N/A (<OB 1537859(1125)><<1537859>>)

Cross Reference Links

Table: <TB 775424(1301)><<TRAINING - QUESTIONS - Track Questions Modified in this Project (CL-OPS-EXAM-ILT)>>
<TB 776284(1305)><<Tracking link in project CL-OPS-EXAM-ILT to source question 2152664>>

Question 41	ID: 2152564	Points: 1.00
-------------	-------------	--------------

<QQ 2152564(1410)><<The reactor is operating at rated thermal power (RTP).

- Residual Heat Removal (RHR) pump 'A' is unavailable due to maintenance.

THEN, a loss of offsite power results in a reactor scram.

The following conditions currently exist:

- Shutdown criteria is met.
- Division 2 Emergency Diesel Generator (EDG) is tripped.
- Reactor Core Isolation Cooling (RCIC) initiated and is currently isolated.
- High Pressure Core Spray (HPCS) initiated then immediately tripped.
- Reactor pressure is being controlled by Safety Relief Valves (SRVs).

Parameter	Value	Trend
RPV water level	+ 35 inches	lowering 10 inches/minute
Drywell (DW) pressure	1.50 psig	rising 0.25 psig/minute

If plant conditions remain as stated and NO operator action is taken, the Automatic Depressurization System (ADS) will automatically initiate in ____ (1) ____ using the ____ (2) ____ pump.>>

- A. <QQ 2152564(1480)><<(1) 2 minutes 28.2 seconds
(2) Residual Heat Removal (RHR) 'C'>>
- B. <QQ 2152564(1480)><<(1) 2 minutes 28.2 seconds
(2) Low Pressure Core Spray (LPCS)>>
- C. <QQ 2152564(1480)><<(1) 19 minutes 48 seconds
(2) Residual Heat Removal (RHR) 'C'>>
- D. <QQ 2152564(1480)><<(1) 19 minutes 48 seconds
(2) Low Pressure Core Spray (LPCS)>>

Answer	<QQ 2152564(1419)><<D>>
--------	-------------------------

Answer Explanation

<QQ 2152564(1412)><<D is correct:

Per CPS 5063.01 Alarm Panel 5063 Annunciators - Row 1, LPCS Pump Auto Start, LPCS initiation is due to RPV Level Low (-145.5 in.) or High Drywell Pressure (1.68 psig). All other Low Pressure Coolant Injection (LPCI) pumps are unavailable.

Per CPS 5066.05 Alarm Panel 5066 Annunciators - Row 5, ADS LOGIC B 105 SEC TIMER INITIATED (typical), ADS initiation logic can be broken down as follows:

Level 1 (<-145.5") - 1B21-N091A And Confirmatory Level 3 - 1B21-N095A And High Drywell Pressure 1B21-N094A	OR	Level 1 (<-145.5") - 1B21-N091A And Confirmatory Level 3 - 1B21-N095A And 6 minute time delay.
AND		
105 Second Time Delay		
AND		
LPCS Discharge Pressure Greater Than 145 psig	OR	RHR A Discharge Pressure Greater than 125 psig.

Using this information, the candidate can determine ADS will automatically initiate in 19 minutes 48 seconds by taking the following steps:

- Calculate how long it takes to reach -145.5" Rx Level 1
- Understand that by the time Level 1 is reached, DW Pressure will already be above 1.68 psig and therefore not relevant to this calculation
- Recognize that based on plant conditions that only the LPCS pump is operating
- Take into account the 105 second timer

Mathematical breakdown to reach the answer:

Calculating how much time it takes to reduce to the Level one ADS initiation signal:

35.0 inches (originally stated level)
 +145.5 inches (level 1 -145.5 inches, made a positive to determine the calculate inches of water)
 180.5 inches

180.5 inches / 10 inches/min (level dropping per minute stated)= 18.05 minutes or
 18 minutes and 3 seconds

18 minutes and 3 seconds + 105 seconds (time delay) = 19 minutes and 48 seconds

Incorrect Responses:

A is incorrect but plausible. This response would be correct if:

- High Drywell pressure alone started the 105 second timer, AND
- the RHR 'C' pump was powered from Div 1 power and the LPCS pump was powered from Div 2.

B is incorrect but plausible. The first part of this response would be correct if High Drywell pressure alone started the 105 second timer. See mathematical breakdown below. The second part of this response is correct.

Mathematical breakdown to reach this distractor:

Calculating how much time it takes to raise Drywell pressure to 1.68 psig:

- 1.68 psig - High Drywell Pressure
- 1.50 psig - current pressure
- .18 psig - pressure until High Drywell Pressure is reached

.18 psig divided by .25 psig = .72 min (to reach 1.68 psig)

.72 x 60 seconds = 43.2 seconds

43.2 seconds + 105 seconds time delay = 148.2 seconds or 2 minutes 28.2 seconds

C is incorrect but plausible. The first part of the response is correct. The second part of this response would be correct if the RHR 'C' pump was powered from Div 1 power and the LPCS pump was powered from Div 2. However, the RHR 'C' pump is unavailable (Div 2 power) while LPCS is available (Div 1 power).>>

Question Information

Topic	<QQ 2152564(1400)><<The reactor is operating at rated thermal power (RTP). Residual Heat Removal (RHR) pump 'A' is una>>				
User ID	<QQ 2152564(1404)><<CL-ILT-N19041>>			System ID	<QQ 2152564(1445)>><<2152564>>
Status	<QQ 2152564(1405)>><<Active>>	Point Value	<QQ 2152564(1441)>><<1.00>>	Time (min)	<QQ 2152564(1408)>><<0>>

Open or Closed Reference	<QQ 2152564(1409)><<CLOSED>>
Operator Type_Cognitive Level	<QQ 2152564(1415)><<RO-HIGH>>
Operator Discipline	<QQ 2152564(1413)><<LO-I>>
10CFR55 Content	<TB 479395(1305)><<CFR: 41.10 Administrative, normal, abnormal, and emergency operating procedures for the facility.>>

References Provided	None
K/A Justification	Question meets the KA because the candidate must demonstrate the ability to monitor reactor water level and determine how long to an ADS initiation.
SRO-Only Justification	N/A
Additional Information	Question is high cog written at the comprehension level. The candidate must recognize the interaction between the ADS and LPCS systems and the conditions necessary to initiate ADS using LPCS (2-RI).

NRC Exams Only			
Question Type	Bank (CL-ILT-N15050)	Difficulty	N/A
Technical Reference and Revision #	<ul style="list-style-type: none"> CPS 5063.01 (1F) Rev. 29cCPS 5066.05 (5A) Rev. 28a 		
Training Objective	218000.07 Given the AUTOMATIC DEPRESSURIZATION (ADS) system, DESCRIBE the systems supporting and the nature of the support.		
Previous NRC Exam Use	ILT 15-1 NRC		

K/A Reference(s)

<CM 237434(1002)><<218000.A4.12>>	Safety Function 3	Tier 2	Group 1	RO Imp: 4.2*	SRO Imp: 4.3*
<CM 237422(1001)><<Ability to manually operate and/or monitor in the control room: (CFR: 41.7 / 45.5 to 45.8)>> <CM 237434(1001)><<Reactor vessel water level>>					

Learning Objective(s)

 <OB 1537860(1101)><<Q41 218000 A4.12 (BH)>>
 User (Sys) ID N/A (<OB 1537860(1125)><<1537860>>)

Cross Reference Links

None

Question 42	ID: 2152563	Points: 1.00
-------------	-------------	--------------

<QQ 2152563(1410)><<The plant is at rated thermal power (RTP).

IMD is scheduled to perform CPS 9433.37 ECCS LPCS Minimum Flow E21-N051 Channel Calibration.

The following actions have been taken per CPS 9433.37 Prerequisites:

- LPCS Pump Min Flow Recirc Valve (1E21-F011) is closed.
- Breaker for 1E21-F011 is open.

ITS LCO 3.5.1 ECCS - Operating _____(1)_____ applicable, and ITS LCO 3.6.1.3 Primary Containment Isolation Valves (PCIVs) _____(2)_____ applicable.>>

- A. <QQ 2152563(1480)><<(1) is (2) is>>
- B. <QQ 2152563(1480)><<(1) is NOT (2) is>>
- C. <QQ 2152563(1480)><<(1) is (2) is NOT>>
- D. <QQ 2152563(1480)><<(1) is NOT (2) is NOT>>

Answer	<QQ 2152563(1419)><<A>>
--------	-------------------------

Answer Explanation

<QQ 2152563(1412)><<A is correct.

Per ITS 3.5.1 ECCS Operating, LCO 3.5.1 is applicable in MODE 1, MODES 2 and 3, except ADS valves are not required to be OPERABLE with reactor steam dome pressure ≥ 150 psig.

Per ITS 3.6.1.3 Primary Containment Isolation Valves (PCIVs), LCO 3.6.1.3 is applicable in MODES 1, 2, and 3. For secondary containment bypass leakage isolation valves, applicability applies during movement of recently irradiated fuel assemblies in the primary or secondary containment.

The plant is operating at rated thermal power (RTP) which can only be done in MODE 1. Therefore, ITS 3.5.1 and ITS 3.6.1.3 are both applicable.

Incorrect Responses:

B is incorrect but plausible. The first part of this response is plausible because even with the LPCS Pump Min Flow Recirc Valve (1E21-F011) closed with its breaker open, the LPCS pump may still be maintained AVAILABLE using a dedicated MCR operator. However, establishing conditions to maintain equipment AVAILABILITY (such as in the performance of a surveillance) does not change the applicability of the

LCO or the necessity to enter the LCO. The second part of this response is correct.

C is incorrect but plausible. The first part of this response is correct. The second part of this response is plausible because the LPCS Pump Min Flow Recirc Valve (1E21-F011) is closed with its breaker open, meeting its CNMT isolation function. However, establishing conditions to meet an LCO required action ahead of time (such as in the performance of a surveillance) does not change the applicability of the LCO or the necessity to enter the LCO.

C is incorrect but plausible. This response is plausible because in both cases with the LPCS Pump Min Flow Recirc Valve (1E21-F011) closed with its breaker open:

- the LPCS pump may still be maintained AVAILABLE using a dedicated MCR operator, AND
- the 1E21-F011 meets its CNMT isolation function.

However, neither case changes the applicability of the LCO or the necessity to enter the LCO.>>

Question Information

Topic	<QQ 2152563(1400)><<The plant is at rated thermal power (RTP). IMD is scheduled to perform CPS 9433.37 ECCS LPCS M>>				
User ID	<QQ 2152563(1404)><<CL-ILT-N19042>>			System ID	<QQ 2152563(1445)><<2152563>>
Status	<QQ 2152563(1405)><<Active>>	Point Value	<QQ 2152563(1441)><<1.00>>	Time (min)	<QQ 2152563(1408)><<0>>

Open or Closed Reference	<QQ 2152563(1409)><<CLOSED>>
Operator Type_Cognitive Level	<QQ 2152563(1415)><<RO-HIGH>>
Operator Discipline	<QQ 2152563(1413)><<LO-I>>
10CFR55 Content	<TB 479395(1305)><<CFR: 41.10 Administrative, normal, abnormal, and emergency operating procedures for the facility.>>

References Provided	None
K/A Justification	Question meets the KA because the candidate must demonstrate the ability to apply PCIV Technical specifications to the LPCS system.
SRO-Only Justification	N/A
Additional Information	Question is high cog question written at the analysis and comprehension level. The candidate must apply system knowledge to the lineup to determine the impact to Tech Spec LCO requirements (3-SPK).

NRC Exams Only

Question Type	Bank (CL-ILT-N14021)	Difficulty	N/A
Technical Reference and Revision #	<ul style="list-style-type: none"> • CPS 3313.01 Rev. 17e • CPS 9433.37 Rev. 34b • ITS 3.5.1 (pg 3.5-1) Amend. 231 • ITS3.6.1.3 (pg3.6-9) Amend. 216 		
Training Objective	209001.12 Given LPCS System operability status OR key parameter indications, plant conditions, and a copy of Tech Specs, DETERMINE if Tech Spec Limiting Condition for Operations have been met, and required actions if any.		
Previous NRC Exam Use	ILT 14-1 NRC		

K/A Reference(s)

<CM 275324(1002)><<B2.2.40>>	Safety Function 3	Tier 3	Group	RO Imp: 3.4	SRO Imp: 4.7
<CM 275324(1001)><<Ability to apply Technical Specifications for a system. (CFR: 41.10 / 43.2 / 43.5 / 45.3)>>					
<CM 246517(1002)><<GS.223002>>	Safety Function 5	Tier 2	Group 1	RO Imp:	SRO Imp:
<CM 246517(1001)><<Primary Containment Isolation System/Nuclear Steam Supply Shut-Off>>					

Learning Objective(s)

 <OB 1537861(1101)><<Q42 223002 2.2.40 (BH)>>
 User (Sys) ID N/A (<OB 1537861(1125)><<1537861>>)

Cross Reference Links

None

Question 43	ID: 2152504	Points: 1.00
-------------	-------------	--------------

<QQ 2152504(1410)><<The plant was operating at rated thermal power when DC MCC 1A de-energized due to a fault.

If the 1H13-P601 keylock switch for ADS SRV 1B21-F041F is taken to OPEN, which scenario below describes:

- the status of power to the red indicating light, and
- the actual position of 1B21-F041F?

	Power to 1H13-P601 1B21-F041F red indicating light	1B21-F041F actual position
Scenario 1	available	open
Scenario 2	available	shut
Scenario 3	NOT available	open
Scenario 4	NOT available	shut

>>

- A. <QQ 2152504(1480)><<Scenario 1>>
- B. <QQ 2152504(1480)><<Scenario 2>>
- C. <QQ 2152504(1480)><<Scenario 3>>
- D. <QQ 2152504(1480)><<Scenario 4>>

Answer	<QQ 2152504(1419)><>
--------	-------------------------

Answer Explanation

<QQ 2152504(1412)><<B is correct. Per CPS 3101.01E001 Main Steam (MS, ADS) Low Voltage Electrical Lineup

Power Supplies (Division 1):

- ADS solenoids - 125 VDC MCC 1A
- Solenoid indicating lights - AB MCC 1A1
- ADS Logic - Division 1 NSPS

Based on the indications in the stem, there is no power to the Division 1 ADS solenoids. Even though Division 1 (ADS Logic A) may be actuated, with no DC power to the solenoids, ADS SRV 1B21-F041F does NOT reposition (remains SHUT). In addition, since power to the indicating lights is unaffected, power to the indicating lights is available.

Incorrect Responses:

A is incorrect but plausible. This response would be correct if the loss of 125 VDC MCC 1A power had no effect on Div 1 ADS (such as if Division 1 solenoids AND indicating lights were powered from AB MCC 1A1), allowing the ADS SRV 1B21-F041F valve to reposition OPEN and indicate OPEN (1B21-F041F Red light - ON).

C is incorrect but plausible. This response would be correct if the ADS SRV indicating lights were powered from DC but the solenoids were powered from AC (the opposite is true). If this were the case, the ADS valve would reposition, but the position indicating lights would not provide indication of position change.

D is incorrect but plausible. This response would be correct if the ADS SRV indicating lights and solenoids were powered from DC, causing a loss of the indicating light function and a loss of power to the valve solenoid.>>

Question Information

Topic	<QQ 2152504(1400)><<The plant was operating at rated thermal power when DC MCC 1A de-energized due to a fault. If >>				
User ID	<QQ 2152504(1404)><<CL-ILT-N19043>>			System ID	<QQ 2152504(1445)><<2152504>>
Status	<QQ 2152504(1405)><<Active>>	Point Value	<QQ 2152504(1441)><<1.00>>	Time (min)	<QQ 2152504(1408)><<0>>

Open or Closed Reference	<QQ 2152504(1409)><<CLOSED>>
Operator Type_Cognitive Level	<QQ 2152504(1415)><<RO-HIGH>>
Operator Discipline	<QQ 2152504(1413)><<LO-I>>
10CFR55 Content	<TB 479395(1305)><<CFR: 41.10 Administrative, normal, abnormal, and emergency operating procedures for the facility.>>

References Provided	None
K/A Justification	This question meets the KA because the candidate must demonstrate knowledge of electrical power supplies to the SRV solenoids to answer the question.
SRO-Only Justification	N/A
Additional Information	This is a high cog question written at the analysis and comprehension level. The candidate must compare current conditions to a loss of power and then predict an outcome after performing a manual action to answer the question. (3-SPK).

NRC Exams Only

Question Type	Bank (CL-ILT-N17009)	Difficulty	N/A
Technical Reference and Revision #	<ul style="list-style-type: none"> CPS 5067.08 (8A) Rev. 31a CPS 3101.01E001 Rev. 16 CPS 3101.01E002 Rev. 7a 		
Training Objective	218000.09 DISCUSS the effect: .b A total loss or malfunction of various plant systems has on the AUTOMATIC DEPRESSURIZATION (ADS) System. 218000.16 EVALUATE the following AUTOMATIC DEPRESSURIZATION (ADS) System indications/responses and DETERMINE if the indication/response is expected and normal..1 Loss of 125VDC Div1 or Div 2		
Previous NRC Exam Use	ILT 17-1 NRC		

K/A Reference(s)

<CM 238349(1002)><<239002.K2.01>>	Safety Function 3	Tier 2	Group 1	RO Imp: 2.8*	SRO Imp: 3.2*
<CM 238348(1001)><<Knowledge of electrical power supplies to the following: (CFR: 41.7)>> <CM 238349(1001)><<SRV solenoids>>					

Learning Objective(s)

 <OB 1537862(1101)><<Q43 239002 K2.01 (PH)>>
 User (Sys) ID N/A (<OB 1537862(1125)><<1537862>>)

Cross Reference Links

None

Question 44	ID: 2152484	Points: 1.00
-------------	-------------	--------------

<QQ 2152484(1410)><<CPS is operating at 25% power to support testing.

- Turbine-Driven Reactor Feed Pump (TDRFP) 'A' is in Standby.
- TDRFP 'B' is operating in AUTO.

THEN, a malfunction causes both Digital Feedwater (DFW) Relays CH A L8 TRIP and CH B L8 TRIP, to fail high.

Assuming NO operator action, how will the plant respond?>>

- A. <QQ 2152484(1480)><<TDRFP 'B' trips ONLY.>>
- B. <QQ 2152484(1480)><<Both TDRFP's trip ONLY.>>
- C. <QQ 2152484(1480)><<Main Turbine and both TDRFP's trip ONLY>>
- D. <QQ 2152484(1480)><<Main Turbine and both TDRFP's trip and a reactor scram on Level 8.>>

Answer	<QQ 2152484(1419)><<C>>
--------	-------------------------

Answer Explanation

<QQ 2152484(1412)><<C is correct.

Per CPS 5002.01 ALARM PANEL 5002 ANNUNCIATORS - ROW 2, DFW Relays (WDD and WDG) exceeding the Level 8 (52") setpoint will result in a trip signal to all reactor feed pumps and the main turbine.

Incorrect responses:

A is incorrect but plausible. Plausible misconception that only the TDRFP in AUTO will trip as a result of the relay failures, and not the standby TDRFP.

B is incorrect but plausible. Plausible misconception that the DFW relay failures will only affect the Feedwater system and not the Main Turbine.

D is incorrect but plausible. There is a Level 8 scram, but per CPS 5004.03 ALARM PANEL 5004 ANNUNCIATORS - ROW 3, the scram trip comes from level detectors 1B21-N683A-D, not the DFW relays. The reactor will scram, but on Level 3 with no feed pumps operating.>>

Question Information

Topic	<QQ 2152484(1400)><<CPS is operating at 25% power to support testing. Turbine-Driven Reactor Feed Pump (TDRFP) 'A' >>				
User ID	<QQ 2152484(1404)><<CL-ILT-N19044>>			System ID	<QQ 2152484(1445)><<2152484>>
Status	<QQ 2152484(1405)><<Active>>	Point Value	<QQ 2152484(1441)><<1.00>>	Time (min)	<QQ 2152484(1408)><<0>>

Open or Closed Reference	<QQ 2152484(1409)><<CLOSED>>
Operator Type_Cognitive Level	<QQ 2152484(1415)><<RO-MEMORY>>
Operator Discipline	<QQ 2152484(1413)><<LO-I>>
10CFR55 Content	<TB 479395(1305)><<CFR: 41.10 Administrative, normal, abnormal, and emergency operating procedures for the facility.>>

References Provided	None
K/A Justification	Question meets the KA because the candidate must demonstrate knowledge of how failure of reactor water level control system relays will affect the Main Turbine.
SRO-Only Justification	N/A
Additional Information	Question is low cog written at the memory level. The candidate must recall facts and information contained in a procedure (1-F).

NRC Exams Only			
Question Type	New	Difficulty	N/A
Technical Reference and Revision #	<ul style="list-style-type: none"> CPS 5002.01 (1Q) Rev. 34c CPS 5004.03 (3A) Rev. 28b 		
Training Objective	259002A.09 DISCUSS the effect: A total loss or malfunction of the FEEDWATER CONTROL System has on the plant.		
Previous NRC Exam Use	None		

K/A Reference(s)

<CM 239086(1002)><<259002.K3.06>>	Safety Function 2	Tier 2	Group 1	RO Imp: 2.8	SRO Imp: 2.8
<CM 239080(1001)><<Knowledge of the effect that a loss or malfunction of the REACTOR WATER LEVEL CONTROL SYSTEM will have on following: (CFR: 41.7 / 45.4) (CFR: 41.7 / 45.5 to 45.8)>> <CM 239086(1001)><<Main turbine>>					

Learning Objective(s)

 <OB 1537863(1101)><<Q44 259002 K3.06 (NL)>>
User (Sys) ID N/A (<OB 1537863(1125)><<1537863>>)

Cross Reference Links

None

Question 45	ID: 2155002	Points: 1.00
-------------	-------------	--------------

<QQ 2155002(1410)><<Which of the following Standby Gas Treatment System (VG) filter train components is/are designed to remove particulate?>>

- A. <QQ 2155002(1480)><<Charcoal Filter ONLY>>
- B. <QQ 2155002(1480)><<Upstream HEPA Filter ONLY>>
- C. <QQ 2155002(1480)><<Pre-Filter and Charcoal Filter>>
- D. <QQ 2155002(1480)><<Pre-Filter and Upstream HEPA Filter>>

Answer	<QQ 2155002(1419)><<D>>
--------	-------------------------

Answer Explanation

<QQ 2155002(1412)><<D is correct.

Per N-CL-OPS-261000 Standby Gas Treatment System:

- The Pre-filter removes large granular and fibrous particles from the air stream to minimize HEPA filter loading.
- The Upstream HEPA (High Efficiency Particulate Air) Filter removes particles as small as 0.3 microns to protect the charcoal adsorber from fouling.
- The Charcoal Filter (Adsorber) removes radioactive and non-radioactive forms of iodine and its compounds from the air stream.

Incorrect Responses:

A is incorrect but plausible based on the misconception that the Charcoal Filter removes particles. The Charcoal Filter is designed to remove of gaseous contaminants from the airstream.

B is incorrect but plausible because it is partially correct. While the Upstream HEPA Filter removes particles, it is not the only component listed that performs that function.

C is incorrect but plausible because it is partially correct. The Pre-Filter is designed to remove large particles, but the plausible misconception is that the Charcoal Filter removes particles. The Charcoal Filter is designed to remove of gaseous contaminants from the airstream.>>

Question Information

Topic	<QQ 2155002(1400)><<Which of the following Standby Gas Treatment System (VG) filter train components is/are designed to>>				
User ID	<QQ 2155002(1404)><<CL-ILT-N19045>>		System ID	<QQ 2155002(1445)><<2155002>>	
Status	<QQ 2155002(1405)><<Active>>	Point Value	<QQ 2155002(1441)><<1.00>>	Time (min)	<QQ 2155002(1408)><<0>>

Open or Closed Reference	<QQ 2155002(1409)><<CLOSED>>
Operator Type_Cognitive Level	<QQ 2155002(1415)><<RO-MEMORY>>
Operator Discipline	<QQ 2155002(1413)><<LO-I>>
10CFR55 Content	<TB 479395(1305)><<CFR: 41.10 Administrative, normal, abnormal, and emergency operating procedures for the facility.>>

References Provided	None
K/A Justification	Question meets the KA because the candidate must demonstrate knowledge of the VG System design features which provide for radioactive particulate filtration.
SRO-Only Justification	N/A
Additional Information	Question is low cog written at the memory level. The candidate must recall the function of components in the VG Filter Train (1-I).

NRC Exams Only			
Question Type	New	Difficulty	N/A
Technical Reference and Revision #	N-CL-OPS-261000 Rev. 6		
Training Objective	261000.03 DESCRIBE the function, operation, interlocks, trips, physical location, and power supplies of the following VG SBTG STANDBY GAS TREATMENT System components. .4 VG Train Pre-Filter .5 VG Train Upstream HEPA Filter .6 VG Train Charcoal Filter		
Previous NRC Exam Use	None		

K/A Reference(s)

<CM 239195(1002)><<261000.K4.04>>	Safety Function 9	Tier 2	Group 1	RO Imp: 2.7	SRO Imp: 2.9
<CM 239191(1001)><<Knowledge of STANDBY GAS TREATMENT SYSTEM design feature(s) and/or interlocks which provide for the following: (CFR: 41.7)>> <CM 239195(1001)><<Radioactive particulate filtration>>					

Learning Objective(s)

 <OB 1537864(1101)><<Q45 261000 K4.04 (NL)>>
 User (Sys) ID N/A (<OB 1537864(1125)><<1537864>>)

Cross Reference Links

Table: <TB 775424(1301)><<TRAINING - QUESTIONS - Track Questions Modified in this Project (CL-OPS-EXAM-ILT)>>
<TB 776244(1305)><<Tracking link in project CL-OPS-EXAM-ILT to source question 2152467>>

Question 46	ID: 2152143	Points: 1.00
-------------	-------------	--------------

<QQ 2152143(1410)><<The plant is operating at rated thermal power (RTP).

- The 4.16 kV Bus 1B1 (1AP09E) is being supplied from its MAIN source.

THEN, 4.16 kV Bus 1B1 voltage lowers to the 1st Level Undervoltage Relay setpoint.

The 4.16 kV Bus 1B1...>>

- A. <QQ 2152143(1480)><<MAIN feeder breaker will trip open and reclose.>>
- B. <QQ 2152143(1480)><<MAIN feeder breaker will trip open and the RESERVE feeder breaker will close.>>
- C. <QQ 2152143(1480)><<DG will start, the RESERVE feeder breaker will open and the MAIN feeder breaker will lock-out; 1B1 Bus DG will tie onto the bus.>>
- D. <QQ 2152143(1480)><<MAIN feeder breaker will trip open and the RESERVE feeder breaker will close; 1B1 Bus DG will start and be running ready to pick up the bus.>>

Answer	<QQ 2152143(1419)><>
--------	-------------------------

Answer Explanation

<QQ 2152143(1412)><<B is correct.

Per N-CL-OPS-262001 Auxiliary Power:

- Each 4.16 kV emergency bus has its own independent Loss Of Power (LOP) instrumentation and associated trip logic.
- The voltage for the Division 1, 2, and 3 buses is monitored by two different undervoltage functions: Loss of Voltage (1st Level) and Degraded Voltage (2nd Level).

The First Level, Loss of Voltage, is indicative of a loss of offsite power. It uses a nominal low voltage setting of ~2870V (Div 1 and 2) and ~2538 (Div 3) with a short 2 sec time delay.

Per CPS 5061.03 Alarm Panel 5061 Annunciators - Row 3 Annunciator 5060-3C AC Undervoltage 4160V Bus (1A1):

- Trip of RAT 'B' (ERAT), and close in of the ERAT (RAT 'B'), if sufficient voltage exists on the standby bus.
-
- If the ERAT (RAT 'B') breaker fails to close, the Div 2 DG will start; the Div 2 Reserve (Main) feeder will open & the Div 2 Main (Reserve) feeder will lock-out; the 4.16 kV Bus 1B1 (1AP09E) will be stripped of its loads; and the Div 2 DG will tie onto the bus.

Incorrect Responses:

A is incorrect but plausible. This response would be correct if 4.16 kV Class 1E emergency bus main feeder breakers were equipped like Switchyard (SY) breakers with an auto reclosure feature which functions to minimize service disruptions. This is not a design feature of 4.16 kV Class 1E emergency bus main feeder breakers, including the 1B1 RAT Feed Breaker which will trip but not reclose.

C is incorrect but plausible. This response would be correct if the 4.16 kV Bus 1B1 reserve breaker failed to close. Since there is no indication in the stem that the 4.16 kV Bus 1B1 reserve breaker failed to close, the ERAT (Reserve) feed breaker will automatically close, reenergizing the 4.16 kV Bus 1B1.

D is incorrect but plausible. This response would be correct if a LOCA signal occurred during the event presented in the stem. The DG will start, but the output breaker will not close if normal AC power is present when the DG reaches rated frequency and voltage (occurs within 12 second of DG start signal). Since there is no indication in the stem of a LOCA, the ERAT (Reserve) feed breaker will automatically close, reenergizing the 4.16 kV Bus 1B1.>>

Question Information

Topic	<QQ 2152143(1400)><<The plant is operating at rated thermal power (RTP). The 4.16 kV Bus 1B1 (1AP09E) is being supplie>>				
User ID	<QQ 2152143(1404)><<CL-ILT-N19046>>		System ID	<QQ 2152143(1445)><<2152143>>	
Status	<QQ 2152143(1405)><<Active>>	Point Value	<QQ 2152143(1441)><<1.00>>	Time (min)	<QQ 2152143(1408)><<0>>

Open or Closed Reference	<QQ 2152143(1409)><<CLOSED>>
Operator Type_Cognitive Level	<QQ 2152143(1415)><<RO-MEMORY>>
Operator Discipline	<QQ 2152143(1413)><<LO-I>>
10CFR55 Content	<TB 479395(1305)><<CFR: 41.10 Administrative, normal, abnormal, and emergency operating procedures for the facility.>>

References Provided	None
K/A Justification	Question meets the KA because the candidate must demonstrate knowledge of the operational implications of breaker control (Loss of Power Instrumentation) as it applies to AC electrical distribution to select the correct response.
SRO-Only Justification	N/A
Additional Information	Question is low cog written at the memory level. The candidate must recall the automatic breaker control sequence that occurs during a 1st level undervoltage event on a safety bus (1-1).

NRC Exams Only			
Question Type	Bank (CL-ILT-A14034)	Difficulty	N/A

Technical Reference and Revision #	CPS 5061.03 (3C) Rev. 30cN-CL-OPS-262001 Rev. 013
Training Objective	262001.05 Discuss the Auxiliary Power system automatic functions/interlocks including purpose, signals, set points, sensing points, when bypassed, how/when they are. .12 Vital 4.16 kV Bus Loss of Power
Previous NRC Exam Use	None

K/A Reference(s)

<CM 239267(1002)><<262001.K5.02>>	Safety Function 6	Tier 2	Group 1	RO Imp: 2.6	SRO Imp: 2.9
<CM 239265(1001)><<Knowledge of the operational implications of the following concepts as they apply to A.C. ELECTRICAL DISTRIBUTION: (CFR: 41.5 / 45.3)>> <CM 239267(1001)><<Breaker control>>					

Learning Objective(s)

 <OB 1537865(1101)><<Q46 262001 K5.02 (BL)>>
 User (Sys) ID N/A (<OB 1537865(1125)><<1537865>>)

Cross Reference Links

None

Question 47	ID: 2152127	Points: 1.00
-------------	-------------	--------------

<QQ 2152127(1410)><<The plant was operating at 52% power when a loss of all off-site power occurred coincident with a large recirculation suction line break.

Which of the following describes WHEN the listed pumps sequence onto their respective buses?

	Immediately After the Respective Bus is Energized	Five (5) Seconds After the Respective Bus Is Energized	Ten (10) Seconds After the Respective Bus Is Energized
Scenario 1	LPCS	RHR A	Div 1 SX
Scenario 2	RHR C	HPCS	Div 3 SX
Scenario 3	RHR A	Div 1 SX	RHR C
Scenario 4	HPCS	Div 3 SX	LPCS

>>

- A. <QQ 2152127(1480)><<Scenario 1>>
- B. <QQ 2152127(1480)><<Scenario 2>>
- C. <QQ 2152127(1480)><<Scenario 3>>
- D. <QQ 2152127(1480)><<Scenario 4>>

Answer	<QQ 2152127(1419)><<A>>
--------	-------------------------

Answer Explanation

<QQ 2152127(1412)><<A is correct.

Per N-CL-OPS-264000 Diesel Generator, the vital bus loads have delay timers which allow controlled starting of large ECCS pumps and related support loads following a LOCA or LOOP. This "sequencing" ensures starting and power availability for loads required for safe shutdown of the plant.

- RHR A, B starts after 5-second timer.
- RHR C and LPCS start immediately.
- Div 1 SX, Div 2 SX pumps start after a 10-second timer.
- Div 3 loads (HPCS, SX) start immediately.

Incorrect Responses:

B is incorrect but plausible based on the misconception that the HPCS pump starts after a 5 second delay and the Div 3 SX pump starts after a 10 second delay (they will both start immediately after the bus is energized).

C is incorrect but plausible based on the misconception that the RHR A pump starts immediately (it will start after a 5 second delay), Div 1 SX pump starts after a 5 second delay (it will start after a 10 second delay) and RHR C pump starts after a 10 second delay (it will start immediately after the bus is

energized).

D is incorrect but plausible based on the misconception that the Div 3 SX pump starts after a 5 second delay and the LPCS pump starts after a 10 second delay (they will both start immediately after the bus is energized).>>

Question Information

Topic	<QQ 2152127(1400)><<The plant was operating at 52% power when a loss of all off-site power occurred coincident with a l>>				
User ID	<QQ 2152127(1404)><<CL-ILT-N19047>>		System ID	<QQ 2152127(1445)><<2152127>>	
Status	<QQ 2152127(1405)><<Active>>	Point Value	<QQ 2152127(1441)><<1.00>>	Time (min)	<QQ 2152127(1408)><<0>>

Open or Closed Reference	<QQ 2152127(1409)><<CLOSED>>
Operator Type_Cognitive Level	<QQ 2152127(1415)><<RO-MEMORY>>
Operator Discipline	<QQ 2152127(1413)><<LO-l>>
10CFR55 Content	<TB 479395(1305)><<CFR: 41.10 Administrative, normal, abnormal, and emergency operating procedures for the facility.>>

References Provided	None
K/A Justification	Question meets the KA because the candidate must demonstrate the ability to understand how and why loads are sequenced onto a bus following re-energization to prevent overloading the bus.
SRO-Only Justification	N/A
Additional Information	Question is low cog written at the memory level. The candidate must recall the automatic sequence of events that occur bus load sequencing actuations (1-l).

NRC Exams Only			
Question Type	Bank (CL-ILT-N15044)	Difficulty	N/A
Technical Reference and Revision #	• N-CL-OPS-264000 Rev. 4		
Training Objective	264000.08 Given the DIESEL GENERATOR/DIESEL FUEL OIL system, DESCRIBE the systems supported and the nature of the support. .3 Diesel Generator load sequencing		
Previous NRC Exam Use	ILT 15-1 NRC		

K/A Reference(s)

<CM 239215(1002)><<262001.A1.02>>	Safety Function 6	Tier 2	Group 1	RO Imp: 3.1	SRO Imp: 3.5
<CM 239213(1001)><<Ability to predict and/or monitor changes in parameters associated with operating the A.C. ELECTRICAL DISTRIBUTION controls including: (CFR: 41.5 / 45.5)>> <CM 239215(1001)><<Effects of loads when energizing a bus>>					

Learning Objective(s)

 <OB 1537866(1101)><<Q47 262001 A1.02 (BL)>>
 User (Sys) ID N/A (<OB 1537866(1125)><<1537866>>)

Cross Reference Links

None

Question 48	ID: 2152063	Points: 1.00
-------------	-------------	--------------

<QQ 2152063(1410)><<Annunciator 5061-1B AUTO TRIP BREAKER (4160V Feeder Breaker) is received in the control room. The following indications are noted:

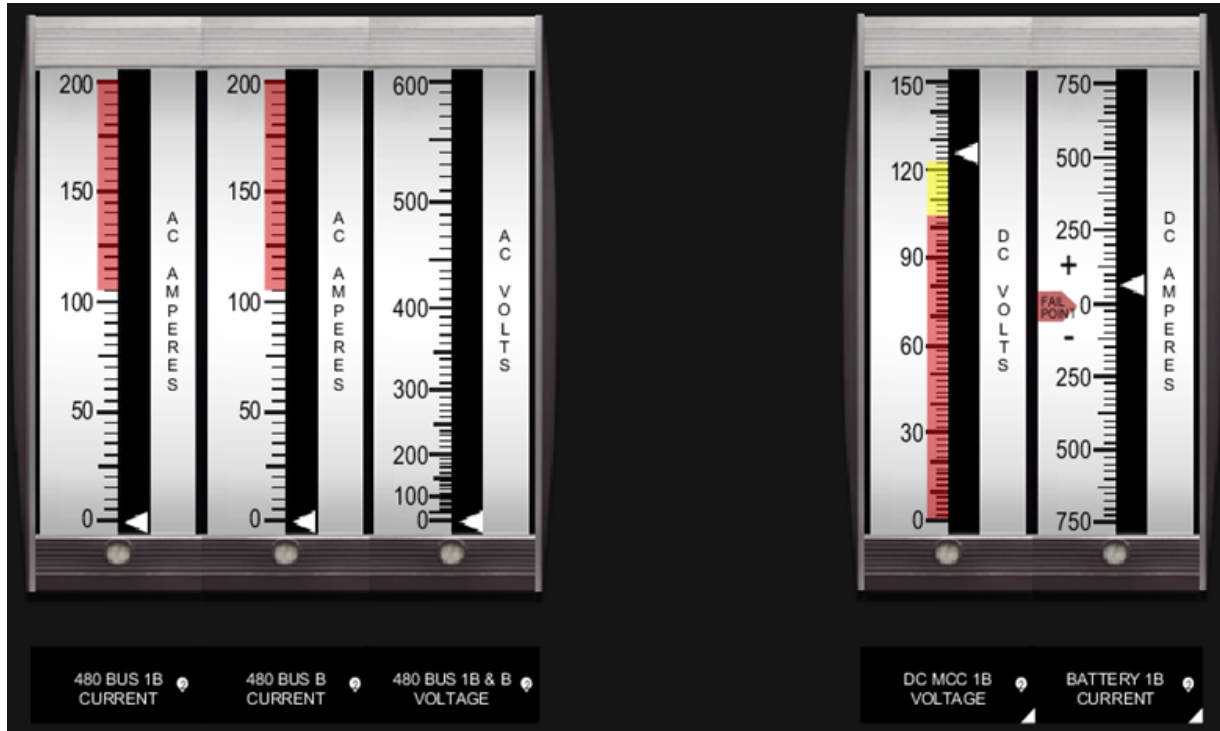

The Div 2 Analog Trip System remains energized because:>>

- A. <QQ 2152063(1480)><<NSPS Solenoid (RPS) Inverter B continues to receive power from its NORMAL supply.>>
- B. <QQ 2152063(1480)><<Div 2 NSPS UPS Static Switch (SS) continues to receive power from its NORMAL supply.>>
- C. <QQ 2152063(1480)><<NSPS Solenoid (RPS) Inverter B has AUTOMATICALLY transferred to and is receiving power from its BACKUP supply.>>
- D. <QQ 2152063(1480)><<Div 2 NSPS UPS Static Switch (SS) has AUTOMATICALLY transferred to and is receiving power from its ALTERNATE supply.>>

Answer	<QQ 2152063(1419)><>
--------	-------------------------

Answer Explanation

<QQ 2152063(1412)><<B is correct.

The NSPS cabinets located in the Main Control Room (MCR) receive 120 VAC from NSPS UPS Power and 120VAC NSPS Solenoid (RPS) Power. Each NSPS cabinet contains two redundant power supply modules energized by NSPS UPS Power which in turn provide power to the Analog Trip System.

The NORMAL supply to the Division 2 NSPS UPS is the Division 2 DC Bus (1DC14E). The ALTERNATE supply to the Division 2 NSPS UPS is the CB MCC F2 (0AP55EB) which is in turn supplied by the 480 V Bus B. The Static Switch (SS) will remain selected to and continue to receive power from its NORMAL supply. See diagram below.

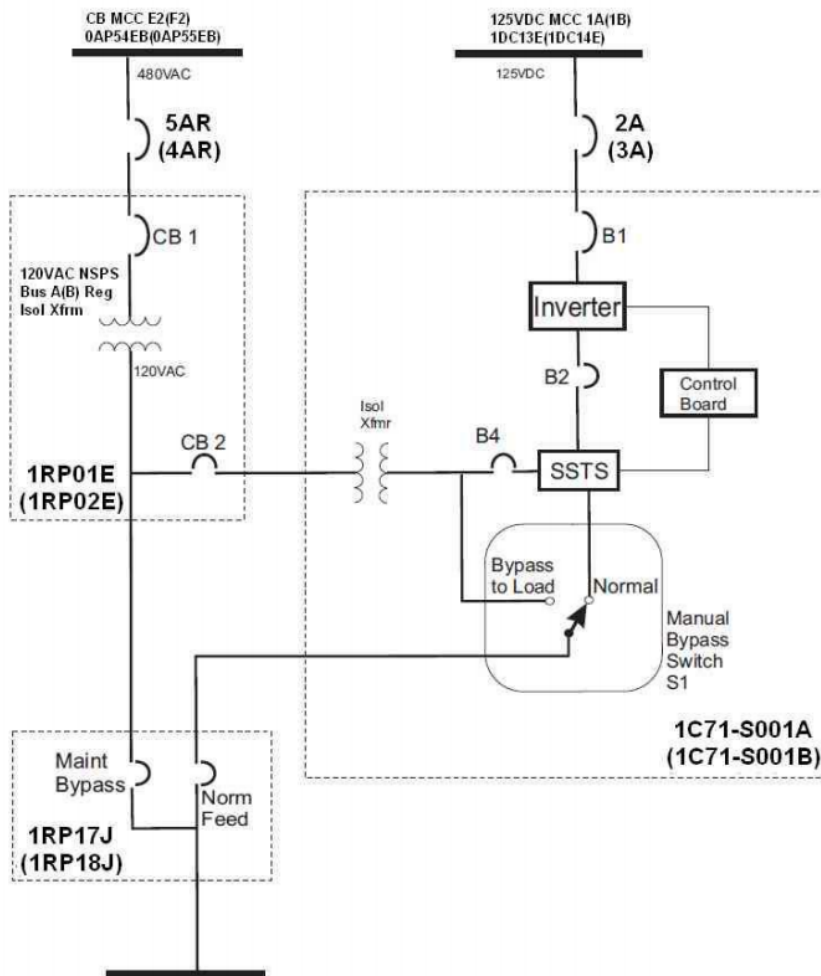

Incorrect Responses:

A is incorrect but plausible. This response would be correct if the Analog Trip System was energized via a NSPS Solenoid (RPS) UPS. Although correct that neither NSPS Solenoid (RPS) UPS is affected by the malfunction, NSPS UPS Power provides power to the Analog Trip System.

C is incorrect but plausible. This response would be correct if:

- the Analog Trip System was energized via a NSPS Solenoid (RPS) UPS, AND
- the NSPS Solenoid (RPS) UPS was affected by the malfunction.

D is incorrect but plausible. This response would be correct if the Div 2 NSPS UPS NORMAL supply was the CB MCC F2 (0AP55EB) while the ALTERNATE supply was the Division 2 DC Bus (1DC14E).>>

Question Information

Topic	<QQ 2152063(1400)><<Annunciator 5061-1B AUTO TRIP BREAKER (4160V Feeder Breaker) is received in the control room. The >>				
User ID	<QQ 2152063(1404)><<CL-ILT-N19048>>		System ID	<QQ 2152063(1445)><<2152063>>	
Status	<QQ 2152063(1405)><<Active>>	Point Value	<QQ 2152063(1441)><<1.00>>	Time (min)	<QQ 2152063(1408)><<0>>

Open or Closed Reference	<QQ 2152063(1409)><<CLOSED>>
Operator Type_Cognitive Level	<QQ 2152063(1415)><<RO-HIGH>>
Operator Discipline	<QQ 2152063(1413)><<LO-I>>
10CFR55 Content	<TB 479395(1305)><<CFR: 41.10 Administrative, normal, abnormal, and emergency operating procedures for the facility.>>

References Provided	None
K/A Justification	Question meets the KA because the candidate must demonstrate knowledge of the effect that a loss or malfunction of AC electrical power will have on an uninterruptable power supply.
SRO-Only Justification	N/A
Additional Information	Question is high cog written at the comprehension level. The candidate must recognize the interaction between the AC distribution and Instrument Power systems. In particular, the candidate must recognize the condition of the AC distribution system based on the graphic presented in the stem, and how it affects the Division 2 NSPS UPS Power Supply (2-RI).

NRC Exams Only			
Question Type	Bank (CL-ILT-N11004 and CL-ILT-N14020)	Difficulty	N/A
Technical Reference and Revision #	<ul style="list-style-type: none"> • CPS 5061.01 (1B) Rev. 29 • E02-1AP03 Sh. 001 Rev. AD • E02-1RP99 Sh. 102 Rev. V 		
Training Objective	700004.02 DESCRIBE the major flowpaths for the following modes of the NSPS System operation. .1 NSPS Divisional Power Normal Flowpath		

	.2 NSPS Divisional Power Alternate Flowpath
Previous NRC Exam Use	ILT 10-1 NRC ILT 14-1 NRC

K/A Reference(s)

<CM 239334(1002)><<262002.K6.01>>	Safety Function 6	Tier 2	Group 1	RO Imp: 2.7	SRO Imp: 2.9
<CM 239333(1001)><<Knowledge of the effect that a loss or malfunction of the following will have on the UNINTERRUPTABLE POWER SUPPLY (A.C./D.C.) : (CFR: 41.7 / 45.7)>> <CM 239334(1001)><<A.C. electrical power>>					

Learning Objective(s)

 <OB 1537867(1101)><<Q48 262002 K6.01 (BH)>>
 User (Sys) ID N/A (<OB 1537867(1125)><<1537867>>)

Question 49

ID: 2152028

Points: 1.00

<QQ 2152028(1410)><<Which of the following graphics show the expected indications immediately after establishing an equalizing charge on the Div 1 Battery?

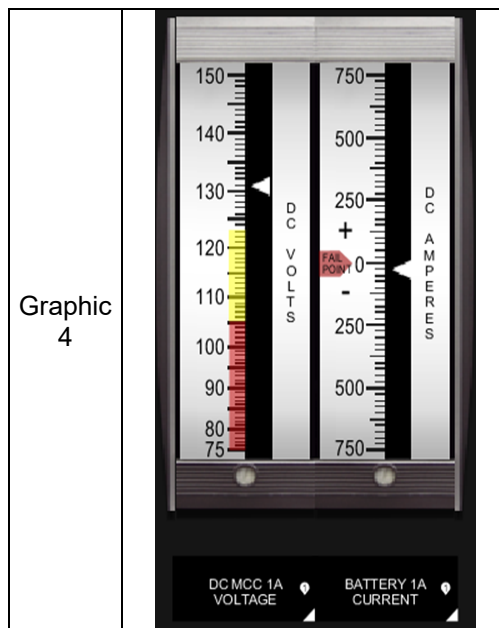
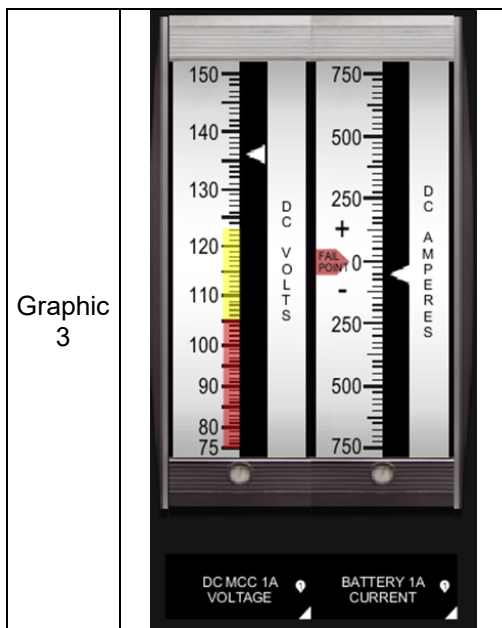
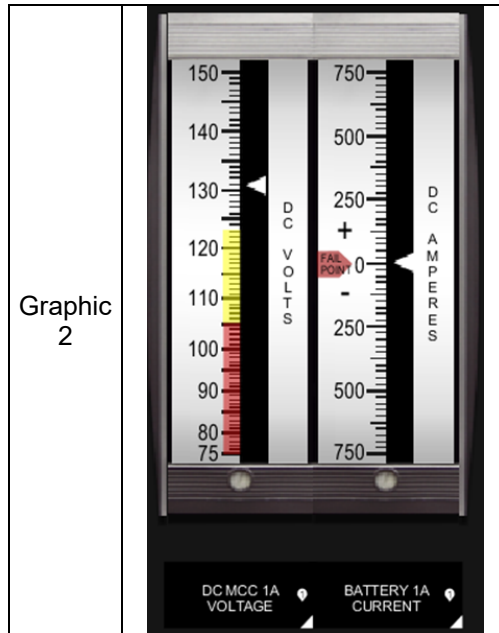
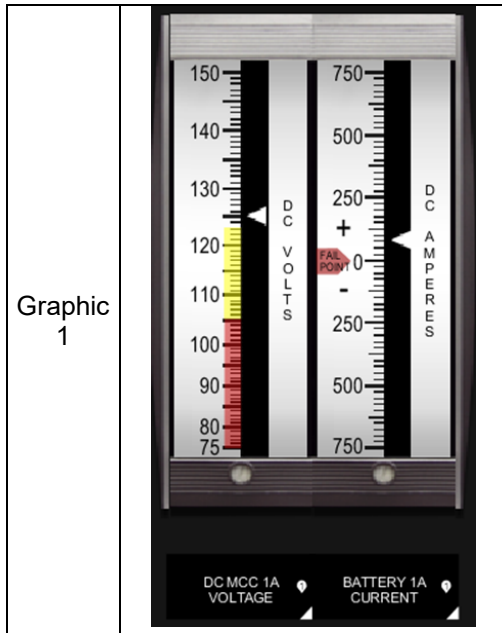

>>

- A. <QQ 2152028(1480)><<Graphic 1>>
- B. <QQ 2152028(1480)><<Graphic 2>>
- C. <QQ 2152028(1480)><<Graphic 3>>
- D. <QQ 2152028(1480)><<Graphic 4>>

Answer	<QQ 2152028(1419)><<C>>
--------	-------------------------

Answer Explanation

<QQ 2152028(1412)><<C is correct:

Per CPS 8433.01 Generic Procedure For 125VDC Battery Maintenance, section 8.3.1 Equalizing 1DC01E (Div 1 Battery), step 8.3.1.6 directs verifying that 1DC01E is at equalize potential, 135.4 to 136.66VDC, using voltmeter to read charger voltage at terminals of charger DC voltmeter after the float/equalize switch is placed in equalize (step 8.3.1.3). This reading is synonymous with the DC MCC 1A Voltage Indicator on 1H13-P877-5060 shown in the graphics of the question stem. Battery amperage will start at a higher value (current flow into the battery) and slowly lower until the battery voltage is equalized with the higher voltage from the Battery Charger. These indications are represented in Graphic #3.

Incorrect Responses:

A is incorrect but plausible. This response is plausible because a misconception exists that current flowing into the battery (i.e., charging) is indicated as positive when read at the ammeter in the MCR. This graphic shows expected indications for a battery charger trip (lower than normal DC MCC 1A Voltage and current flow out of the associated battery - battery is discharging).

B is incorrect but plausible. This response is plausible because it shows expected indications for a battery charger in float (voltage is higher than 125VDC and a slight current flow into the associated battery). This response is incorrect because the voltage reading is below that required for an equalizing charge (135.4 to 136.66VDC).

D is incorrect but plausible. This response is plausible because it shows a negative current (current flow into the battery) and a voltage higher than 125VDC. However, this response is incorrect because the voltage reading is below that required for an equalizing charge (135.4 to 136.66VDC).>>

Question Information

Topic	<QQ 2152028(1400)><<Which of the following graphics show the expected indications immediately after establishing an equ>>				
User ID	<QQ 2152028(1404)><<CL-ILT-N19049>>		System ID	<QQ 2152028(1445)><<2152028>>	
Status	<QQ 2152028(1405)><<Active>>	Point Value	<QQ 2152028(1441)><<1.00>>	Time (min)	<QQ 2152028(1408)><<0>>

Open or Closed Reference	<QQ 2152028(1409)><<CLOSED>>
Operator Type_Cognitive Level	<QQ 2152028(1415)><<RO-HIGH>>
Operator Discipline	<QQ 2152028(1413)><<LO-I>>
10CFR55 Content	<TB 479395(1305)><<CFR: 41.10 Administrative, normal, abnormal, and emergency operating procedures for the facility.>>

References Provided	None
K/A Justification	This question meets the KA because the examinee must demonstrate the ability to predict and/or monitor changes in parameters associated with operating the D.C. ELECTRICAL DISTRIBUTION controls including battery charging / discharging rate to answer the question.
SRO-Only Justification	N/A
Additional Information	Question is written at the analysis and comprehension level. The candidate must analyze 4 graphics in the stem and then determine which one provides indication of an equalizing charge based on knowledge of the equalizing function of the Divisional Battery Chargers to answer the question. (3-SPK)

NRC Exams Only			
Question Type	Bank (from CL-ILT-1268992, CL-ILT-2036329 and CL-ILT-N17011)	Difficulty	N/A
Technical Reference and Revision #	<ul style="list-style-type: none"> CPS 8433.01 Rev. 29 		

Training Objective	263000.03 DESCRIBE the function, operation, interlocks, trips, physical location and power supplies of the following BATTERY & DC DISTRIBUTION System components. .1 Batteries .2 Battery Chargers .3 DC Motor Control Centers .4 High DC Voltage Shutdown Relays .5 DC Shunt Trips .6 Float/Equalize Switch .7 Ground detectors
Previous NRC Exam Use	ILT 17-1 NRC

K/A Reference(s)

<CM 239340(1002)><<263000.A1.01>>	Safety Function 6	Tier 2	Group 1	RO Imp: 2.5	SRO Imp: 2.8
<CM 239339(1001)><<Ability to predict and/or monitor changes in parameters associated with operating the D.C. ELECTRICAL DISTRIBUTION controls including: (CFR: 41.5 / 45.5)>> <CM 239340(1001)><<Battery charging/discharging rate>>					

Learning Objective(s)

 <OB 1537868(1101)><<Q49 263000 A1.01 (PH)>>
 User (Sys) ID N/A (<OB 1537868(1125)><<1537868>>)

Cross Reference Links

None

Question 50	ID: 2152002	Points: 1.00
-------------	-------------	--------------

<QQ 2152002(1410)><<The plant is operating at rated thermal power.

Div 1 DG is operating in parallel with off-site power.

DG parameters are as follows:

- 3750 KW
- 3500 KVAR

Under these conditions, which of the following statements is correct? (See attached DG 1A Reactive Load Capability Curve.)

The Div 1 DG is operating...>>

- A. <QQ 2152002(1480)><<outside the capability curve; reduce KW loading by approximately 700 KW.>>
- B. <QQ 2152002(1480)><<outside the capability curve; Reduce KVAR loading by approximately 700 KVARs.>>
- C. <QQ 2152002(1480)><<within the capability curve; KVAR can be raised as long as power factor is maintained below the 0.7 pf line.>>
- D. <QQ 2152002(1480)><<within the capability curve; KW can be raised as long as the continuous KW load rating is NOT exceeded.>>

Answer	<QQ 2152002(1419)><>
--------	-------------------------

Answer Explanation

<QQ 2152002(1412)><<B is correct:

Per CPS 3506.01 Limitation 6.1.5:

- The DG shall also be operated within the limits of Appendix A, DG 1A(1B) Reactive Load Capability Curve or Appendix B, DG 1C Reactive Load Capability Curve as applicable.
- The DG should be operated at a power factor between 0.8 lagging and 1.0 to observe machine design ratings and minimize circulating currents.

Per CPS 3506.01 Appendix A DG 1A(1B) Reactive Load Capability Curve, the maximum VAR loading for 3750 KW and 0.8 pf is approximately 2812 KVARs. At 3500 KVARs, Div 1 DG is operating outside the limits of the capability curve. To reduce VAR loading to within limits, DG voltage must be reduced by positioning the voltage regulator control switch to lower.

Incorrect Responses:

A is incorrect but plausible. This response could be correct since reducing KW loading enough will restore the DG to within the limits of the capability curve, however a 700 KW reduction is still outside the limits of the capability curve (dark black line).

C is incorrect but plausible. This response could be correct if the 0.7 pf line was limiting beyond the capability curve (dark black line). Plausible since DG 1A is operating below the 0.7 pf line for the current KVAR loading (approximately 3812 KVAR @ 3750 KW), however this KVAR loading is outside the limits of the capability curve and raising the KVAR loading to a higher value will exacerbate the situation. Since this scenario is outside the limits of the capability curve it is not allowed.

D is incorrect but plausible. This response could be correct if the 0.7 pf line was limiting beyond the capability curve (dark black line). Plausible since DG 1A is operating below the 0.7 pf line for the current KVAR loading (approximately 3812 KVAR @ 3750 KW), however this KVAR loading is outside the limits of the capability curve and raising the KW loading to a higher value will exacerbate the situation. Since this scenario is outside the limits of the capability curve it is not allowed.>>

Question Information

Topic	<QQ 2152002(1400)><<The plant is operating at rated thermal power. Div 1 DG is operating in parallel with off-site p>>				
User ID	<QQ 2152002(1404)><<CL-ILT-N19050>>		System ID	<QQ 2152002(1445)>><<2152002>>	
Status	<QQ 2152002(1405)>><<Active>>	Point Value	<QQ 2152002(1441)>><<1.00>>	Time (min)	<QQ 2152002(1408)>><<0>>

Open or Closed Reference	<QQ 2152002(1409)><<OPEN>>
Operator Type_Cognitive Level	<QQ 2152002(1415)><<RO-HIGH>>
Operator Discipline	<QQ 2152002(1413)><<LO-I>>
10CFR55 Content	<TB 479395(1305)><<CFR: 41.10 Administrative, normal, abnormal, and emergency operating procedures for the facility.>>

References Provided	CPS 3506.01 Appendix A
K/A Justification	Question meets the K/A because the candidate must predict the impact of parallel operation of a DG outside its limits and based on those predictions use procedures to correct the consequences.
SRO-Only Justification	N/A
Additional Information	Question is high cog written at the analysis & comprehension level. The candidate must analyze the conditions presented in the stem and use a reference to determine an abnormal condition and the action necessary to correct that condition to answer the question (3-SPK/SPR).

NRC Exams Only			
Question Type	Bank (CL-ILT-N12040)	Difficulty	N/A
Technical Reference and Revision #	CPS 3506.01 Rev. 40a		
Training Objective	264000.10 EXPLAIN the reasons for given DIESEL GENERATOR/DIESEL FUEL OIL System operating limits and precautions.		
Previous NRC Exam Use	ILT 12-1 NRC		

K/A Reference(s)

<CM 239384(1002)><<264000.A2.01>>	Safety Function 6	Tier 2	Group 1	RO Imp: 3.5	SRO Imp: 3.6
<CM 239383(1001)><<Ability to (a) predict the impacts of the following on the EMERGENCY GENERATORS (DIESEL/JET) ; and (b) based on those predictions, use procedures to correct, control, or mitigate the consequences of those abnormal conditions or operations: (CFR: 41.5 / 45.6)>> <CM 239384(1001)><<Parallel operation of emergency generator>>					

Learning Objective(s)

 <OB 1537869(1101)><<Q50 264000 A2.01 (BH)>>
 User (Sys) ID N/A (<OB 1537869(1125)><<1537869>>)

Cross Reference Links

None

Question 51	ID: 2151629	Points: 1.00
-------------	-------------	--------------

<QQ 2151629(1410)><<Plant conditions occurred as follows:

- A plant heatup and pressurization is in progress.
- Service Air Compressor #0 (0SA01C) is in service.
- Service Air Compressor #1 (1SA01C) is in standby.
- Service Air Dryers #0 (0SA01D) and #1 (1SA01D) are in service.

Annunciator 5041-3B, TROUBLE INSTRUMENT AIR DRYER 0SA02J, has just alarmed. An Equipment Operator (EO) is dispatched to investigate.

- The EO reports that the only alarm light lit on 0SA02J is an After Filter Hi D/P alarm.
- NO additional operator actions have yet been taken.

Which of the following identifies the response of the #0 SA Dryer Bypass Valve? What actions are required?>>

- A. <QQ 2151629(1480)><<#0 Dryer bypass OPENS; Place the #2 Dryer in service and isolate the #0 Dryer ONLY.>>
- B. <QQ 2151629(1480)><<#0 Dryer bypass remains SHUT; Place the #2 Dryer in service and isolate the #0 Dryer ONLY.>>
- C. <QQ 2151629(1480)><<#0 Dryer bypass OPENS; Place the #2 Compressor and #2 Dryer in service and secure/isolate the #0 Compressor and #0 Dryer.>>
- D. <QQ 2151629(1480)><<#0 Dryer bypass remains SHUT; Place the #2 Compressor and #2 Dryer in service and secure/isolate the #0 Compressor and #0 Dryer.>>

Answer	<QQ 2151629(1419)><>
--------	-------------------------

Answer Explanation

<QQ 2151629(1412)><<B is correct. Per CPS 5041.03 ALARM PANEL 5041 ANNUNCIATORS - ROW 3, MCR annunciator 5041-3B TROUBLE INSTRUMENT AIR DRYER 0SA02J is brought in by multiple devices alarming the local panel 0SA02J. They are:

- Dryer Chamber A & B Press (55 psig)
- Dryer Outlet Low Press (70 psig)
- Pre-Filter Hi d/p (10 psig)
- After Filter Hi d/p (10 psig)
- Humidity Sensor - relative (3%)

The ONLY Automatic Action that occurs in conjunction with this annunciator is that the Dryer Bypass valve OPENS if Dryer outlet pressure falls to 70 psig. Based on the conditions presented in the stem, this

condition is NOT met and the Dryer Bypass valve does NOT reposition.

The applicable Operator Actions directed by the annunciator procedure are as follows:

If the SA Dryer has trouble due to switching failure, low outlet pressure, high prefilter/after filter d/p, then:

- Place the spare SA dryer in service.
- Isolate the affected SA dryer.

Incorrect Responses:

A is incorrect but plausible based on the misconception that any time the 5041-3B annunciator alarms (i.e. for After Filter Hi d/p), the #0 Dryer bypass valve OPENS (instead of on Dryer outlet low pressure ONLY). The second part of the response is correct.

C is incorrect but plausible based on the misconception that any time the 5041-3B annunciator alarms (i.e. for After Filter Hi d/p), the #0 Dryer bypass valve OPENS (instead of on Dryer outlet low pressure ONLY), and the misconception that each service air dryer is connected in series to its respective service air compressor and therefore they would be placed into service or removed from service as a pair (i.e. #0 Compressor/#0 Dryer, #1 Compressor/#1 Dryer, etc.). Several paired plant components do operate in this manner, but the Service Air Compressors do not.

D is incorrect but plausible based on the misconception that each service air dryer is connected in series to its respective service air compressor and therefore they would be placed into service or removed from service as a pair (i.e. #0 Compressor/#0 Dryer, #1 Compressor/#1 Dryer, etc.). Several paired plant components do operate in this manner, but the Service Air Compressors do not.>>

Question Information

Topic	<QQ 2151629(1400)><<Plant conditions occurred as follows: A plant heatup and pressurization is in progress. Service >>				
User ID	<QQ 2151629(1404)><<CL-ILT-N19051>>			System ID	<QQ 2151629(1445)><<2151629>>
Status	<QQ 2151629(1405)><<Active>>	Point Value	<QQ 2151629(1441)><<1.00>>	Time (min)	<QQ 2151629(1408)><<0>>

Open or Closed Reference	<QQ 2151629(1409)><<CLOSED>>
Operator Type_Cognitive Level	<QQ 2151629(1415)><<RO-MEMORY>>
Operator Discipline	<QQ 2151629(1413)><<LO-I>>
10CFR55 Content	<TB 479395(1305)><<CFR: 41.10 Administrative, normal, abnormal, and emergency operating procedures for the facility.>>

References Provided	None
K/A Justification	Question meets the KA because the candidate must predict the impact of an air dryer malfunction

	and based on those predictions, use an applicable procedure to mitigate the malfunction.
SRO-Only Justification	N/A
Additional Information	Question is low cog written at the memory level. The candidate must recall the automatic response of the Service Air Dryers to an alarm (1-I).

NRC Exams Only			
Question Type	Bank (CL-ILT-N14009)	Difficulty	N/A
Technical Reference and Revision #	<ul style="list-style-type: none"> CPS 5041.03 (3B) Rev. 26a 		
Training Objective	300000.06 Given a Service and Instrument Air System Annunciator, DESCRIBE: <ol style="list-style-type: none"> The condition causing the annunciator Any automatic actions Any operational implications 		
Previous NRC Exam Use	ILT 14-1 NRC		

K/A Reference(s)

<CM 241713(1002)><<300000.A2.01>>	Safety Function 8	Tier 2	Group 1	RO Imp: 2.9	SRO Imp: 2.8
<CM 241712(1001)><<Ability to (a) predict the impacts of the following on the INSTRUMENT AIR SYSTEM and (b) based on those predictions, use procedures to correct, control, or mitigate the consequences of those abnormal operation: (CFR: 41.5 / 45.6)>> <CM 241713(1001)><<Air dryer and filter malfunctions>>					

Learning Objective(s)

 <OB 1537870(1101)><<Q51 300000 A2.01 (BL)>>
 User (Sys) ID N/A (<OB 1537870(1125)><<1537870>>)

Cross Reference Links

None

Question 52	ID: 2151635	Points: 1.00
-------------	-------------	--------------

<QQ 2151635(1410)><<A plant startup is in progress. Reactor power is at approximately 45% of rated thermal power (RTP).

Plant loads in operation include:

- 1A, 1B, & 1C Condensate Booster (CB) Pumps
- 1A, 1C, & 1D Condensate (CD) Pumps
- 1B & 1C Component Cooling Water (CCW) Pumps
- 1A Control Rod Drive (CRD) Water Pump
- #1 Service Air Compressor (SAC) with #2 SAC in standby

THEN, 4160V Bus 1B deenergizes due to an over current condition.

What action would the affected Reactor Operator (RO) take NEXT?>>

- A. <QQ 2151635(1480)><<Start the #0 SAC.>>
- B. <QQ 2151635(1480)><<Place the Mode Switch in SHUTDOWN.>>
- C. <QQ 2151635(1480)><<Shut the affected RR pump discharge block valve.>>
- D. <QQ 2151635(1480)><<Close CRD Drive Water Flow Control Valve (1C11-F002B).>>

Answer	<QQ 2151635(1419)><<A>>
--------	-------------------------

Answer Explanation

<QQ 2151635(1412)><<A is correct.

Per CPS 3214.01E001 Plant Air Electrical Lineup, the Service Air Compressor (SAC) supplies are as follows:

- #0 SAC - 4160V Bus 1A
- #1 SAC - 4160V Bus 1B
- #2 SAC - 4160V Bus 1B

Therefore, a loss of 4160V Bus 1B would result in a loss of #1 & #2 SACs (running and standby).

Per CPS 5041.01 Alarm Panel 5041 Annunciators - Row 1 for AUTO TRIP SERVICE AIR COMPRESSOR (5041-1A), the first operator action would be to start the standby Service Air Compressor. The #0 SAC is unaffected by the transient and is available to start.

Incorrect Responses:

B is incorrect but plausible. This answer would be correct if NO Component Cooling Water (CCW) pumps were running. However, only the 1B CCW pump is supplied from the 4160V Bus 1B and the 1C CCW pump is still in operation.

C is incorrect but plausible. This answer would be correct if Reactor Recirculation (RR) pumps were operating in SLOW speed. However, RR pumps are normally shifted to FAST at ~ 30% reactor power and the current reactor power is 43%.

D is incorrect but plausible. This answer would be correct if the running CRD Water Pump had tripped. However, only the 1B CRD water pump is supplied from the 4160V Bus 1B and the (running) 1A CRD water pump is unaffected.>>

Question Information

Topic	<QQ 2151635(1400)><<A plant startup is in progress. Reactor power is at approximately 45% of rated thermal power (RTP)>>				
User ID	<QQ 2151635(1404)><<CL-ILT-N19052>>		System ID	<QQ 2151635(1445)><<2151635>>	
Status	<QQ 2151635(1405)><<Active>>	Point Value	<QQ 2151635(1441)><<1.00>>	Time (min)	<QQ 2151635(1408)><<0>>

Open or Closed Reference	<QQ 2151635(1409)><<CLOSED>>
Operator Type_Cognitive Level	<QQ 2151635(1415)><<RO-HIGH>>
Operator Discipline	<QQ 2151635(1413)><<LO-I>>
10CFR55 Content	<TB 479395(1305)><<CFR: 41.10 Administrative, normal, abnormal, and emergency operating procedures for the facility.>>

References Provided	None
K/A Justification	Question meets the KA because the candidate must demonstrate knowledge of electrical power supplies to Instrument Air / Service Air compressors to answer the question.
SRO-Only Justification	N/A
Additional Information	Question is high cog written at the analysis & comprehension level. The candidate must analyze the conditions presented in the stem and determine which equipment is lost and the actions required to mitigate that loss to answer the question (3-SPK).

NRC Exams Only			
Question Type	Bank (CL-ILT-637420)	Difficulty	N/A
Technical Reference and Revision #	<ul style="list-style-type: none"> CPS 3214.01E001 Rev. 10a CPS 3203.01E001 Rev. 17a 		

	<ul style="list-style-type: none"> • CPS 3304.01E001 Rev. 7 • CPS 3302.01E001 Rev. 12b • CPS 5041.01 (1A) Rev. 30c • CPS 5040.01 (1B) Rev. 28d • CPS 5068.03 (3B) Rev. 26a • CPS 3304.01 Rev. 38c • CPS 4008.01 Rev. 20e
Training Objective	<p>300000.07</p> <p>Given the Service and Instrument Air system, DESCRIBE the systems supporting and the nature of the support.</p>
Previous NRC Exam Use	None

K/A Reference(s)

<CM 241726(1002)><<300000.K2.01>>	Safety Function 8	Tier 2	Group 1	RO Imp: 2.8	SRO Imp: 2.8
<CM 241725(1001)><<Knowledge of electrical power supplies to the following: (CFR: 41.7)>> <CM 241726(1001)><<Instrument air compressor>>					

Learning Objective(s)

 <OB 1537871(1101)><<Q52 300000 K2.01 (BH)>>
 User (Sys) ID N/A (<OB 1537871(1125)><<1537871>>)

Cross Reference Links

None

Question 53	ID: 2151662	Points: 1.00
-------------	-------------	--------------

<QQ 2151662(1410)><<CPS is operating at Rated Thermal Power (RTP) and Component Cooling Water (CCW) system header pressure must be LOWERED.

To accomplish this, the RO will direct the Equipment Operator in the field to throttle 1CC080 FC Return Line Throttle Valve in the ____ (1) ____ direction, which will cause FC Motor Heat Exchanger flow to ____ (2) ____.>>

- A. <QQ 2151662(1480)><<(1) closed
(2) rise>>
- B. <QQ 2151662(1480)><<(1) closed
(2) NOT change>>
- C. <QQ 2151662(1480)><<(1) open
(2) rise>>
- D. <QQ 2151662(1480)><<(1) open
(2) NOT change>>

Answer	<QQ 2151662(1419)><<C>>
--------	-------------------------

Answer Explanation

<QQ 2151662(1412)><<C is correct:

Per M05-1032-2 at B2, 1CC080 FC Return Line Throttle Valve is located on the effluent of the FC Heat Exchangers. When opened, it causes CCW Header pressure to lower due to increasing the flow through the FC Heat Exchangers.

CPS 3317.01 Fuel Pool Cooling and Cleanup (FC), section 8.1.2.4 cautions the operator to monitor FC Pump Motor Cooler Flow, while adjusting 1CC080. The in-service FC Pump will trip if Motor Cooler Hx flow < 12.2 gpm for > 100 sec.

CPS 3317.01 (Note before step 8.1.2.4.5) states that opening 1CC080 will raise FC pump motor cooling flow.

Incorrect Responses:

A is incorrect but plausible based on the misconception that closing 1CC080 will cause FC Motor Heat Exchanger flow to increase and CCW pressure to lower.

B is incorrect but plausible based on the misconception that closing 1CC080 will cause FC Motor Heat Exchanger flow to increase and CCW pressure to lower, and the misconception that like smaller pumps, the FC Pump Motor Coolers are cooled by the fluid flowing through the system (FC), instead of CCW.

D is incorrect but plausible based on the misconception that like smaller pumps, the FC Pump Motor

Coolers are cooled by the fluid flowing through the system (FC), instead of CCW.>>

Question Information

Topic	<QQ 2151662(1400)><<CPS is operating at Rated Thermal Power (RTP) and Component Cooling Water (CCW) system header press>>				
User ID	<QQ 2151662(1404)><<CL-ILT-N19053>>		System ID	<QQ 2151662(1445)><<2151662>>	
Status	<QQ 2151662(1405)><<Active>>	Point Value	<QQ 2151662(1441)><<1.00>>	Time (min)	<QQ 2151662(1408)><<0>>

Open or Closed Reference	<QQ 2151662(1409)><<CLOSED>>
Operator Type_Cognitive Level	<QQ 2151662(1415)><<RO-HIGH>>
Operator Discipline	<QQ 2151662(1413)><<LO-I>>
10CFR55 Content	<TB 479395(1305)><<CFR: 41.10 Administrative, normal, abnormal, and emergency operating procedures for the facility.>>

References Provided	None
K/A Justification	Question meets the KA because the candidate must demonstrate the ability to manually operate and / or monitor in the control room COMPONENT COOLING WATER SYSTEM (CCWS) indications and controls to answer this question.
SRO-Only Justification	N/A
Additional Information	Question is written at the comprehension level (high cog). The candidate must recognize the interaction between the CCW and FC systems, specifically to the FC Motor Heat Exchanger flow when 1CC080 FC Return Line Throttle Valve is repositioned (2-RI).

NRC Exams Only			
Question Type	Bank (duplicate of CL-ILT-N12055, CL-ILT-2030609 and CL-ILT-N17005)	Difficulty	N/A
Technical Reference and Revision #	<ul style="list-style-type: none"> • CPS 3203.01 Rev. 37 • CPS 3317.01 Rev. 33e 		

	<ul style="list-style-type: none"> M05-1032 Sheet 2 of 5 Rev. R
Training Objective	400001.16 EVALUATE the following Component Cooling Water indications/responses and DETERMINE if the indication/ response is expected and normal.
Previous NRC Exam Use	ILT 12-1 NRC Exam ILT 17-1 NRC Exam

K/A Reference(s)

<CM 241780(1002)><<400000.A4.01>>	Safety Function 8	Tier 2	Group 1	RO Imp: 3.1	SRO Imp: 3.0
<CM 241779(1001)><<Ability to manually operate and / or monitor in the control room: (CFR: 41.7 / 45.5 to 45.8)>> <CM 241780(1001)><<CCW indications and control>>					

Learning Objective(s)

 <OB 1537872(1101)><<Q53 400000 A4.01 (PH)>>
 User (Sys) ID N/A (<OB 1537872(1125)><<1537872>>)

Cross Reference Links

None

Question 54	ID: 2157003	Points: 1.00
-------------	-------------	--------------

<QQ 2157003(1410)><<A reactor plant shutdown is in progress.

The 'A' RO has just completed inserting control rod 24-33 from position 48 to position 12.

THEN, annunciator 5006-4G Rod Drift comes in and the 'A' RO notes control rod 24-33 is at position 14 and continuing to move outward.

Which of the following could cause this behavior?>>

- A. <QQ 2157003(1480)><<Rod 24-33 hydraulic control unit (HCU) has depressurized.>>
- B. <QQ 2157003(1480)><<Rod 24-33 collet piston has stuck at the upper limit of travel.>>
- C. <QQ 2157003(1480)><<Control rod drive (CRD) flow control valve (FCV) has failed open.>>
- D. <QQ 2157003(1480)><<Rod 24-33 directional control valves (DCVs) 121 and 123 have failed open.>>

Answer	<QQ 2157003(1419)><>
--------	-------------------------

Answer Explanation

<QQ 2157003(1412)><<B is correct.

Per N-CL-OPS-201003 Control Rod and Control Rod Drive Mechanism and CPS/USAR 4.6.2.3.2.2.11 Collet Fingers Fail to Latch:

- The Collet Fingers ratchet out along the tapered notch surface during control rod insertion, and engage to stop the Index Tube at notch positions.
- At Peach Bottom in 1996, 3 Control Rods in succession commenced drifting out when withdrawn one notch. These 3 rod rod drive mechanisms were peripheral rod drive mechanisms. General Electric SIL #310 "STUCK CRD COLLET" addresses this situation. The SIL states that drifting has been attributed to foreign material from the Reactor Pressure Vessel entered and lodging in the collet seal area causing the collet piston to bind.

If the collet piston sticks at the upper limit of travel, the collet fingers would not be able to engage in the Index Tube notches, allowing the rod to drift out.

Incorrect Responses:

A is incorrect but plausible. This response is plausible because accumulators such as those used for Safety/Relief Valves (SRVs) maintain the valves open. If depressurized, these accumulators may allow the valves associated with them to drift off their open seats or close. However, the control rod accumulator is used to ensure that the control rod will fully insert at any reactor vessel pressure. Depressurizing an HCU accumulator could only affect the time required to scram the rod and would not result in a rod drift (outward).

C is incorrect but plausible. This response is plausible because a failed open CRD FCV would cause CRD cooling water flow to surge. Increased cooling water flow will cause control rods to insert and does not result in a rod drift outward.

D is incorrect but plausible. This response is plausible because failing open DCVs 121 and 123 would result in applying drive pressure on the P-under port of the CRDM, which causes the rod to insert, not drift outward.>>

Question Information

Topic	<QQ 2157003(1400)><<A reactor plant shutdown is in progress. The 'A' RO has just completed inserting control rod 24->>				
User ID	<QQ 2157003(1404)><<CL-ILT-N19054>>		System ID	<QQ 2157003(1445)><<2157003>>	
Status	<QQ 2157003(1405)><<Active>>	Point Value	<QQ 2157003(1441)><<1.00>>	Time (min)	<QQ 2157003(1408)><<0>>

Open or Closed Reference	<QQ 2157003(1409)><<CLOSED>>
Operator Type_Cognitive Level	<QQ 2157003(1415)><<RO-HIGH>>
Operator Discipline	<QQ 2157003(1413)><<LO-I>>
10CFR55 Content	<TB 479395(1305)><<CFR: 41.10 Administrative, normal, abnormal, and emergency operating procedures for the facility.>>

References Provided	None
K/A Justification	Question meets the KA because the candidate must demonstrate the ability to evaluate plant conditions and based on operating characteristics make a judgement call as to the cause of those conditions.
SRO-Only Justification	NA
Additional Information	Question is high cog written at the analysis & comprehension level. The candidate must analyze the conditions provided in the stem and then determine the cause for those conditions to answer the question (3-SPK).

NRC Exams Only			
Question Type	Bank (CL-ILT-1402)	Difficulty	NA
Technical Reference and Revision #	<ul style="list-style-type: none"> N-CL-OPS-201003 Rev. 3 CPS/USAR CH 04 (4.6-24) Rev. 11 		
Training Objective	201003.15		

	Given the Control Rod Drive Mechanism System initial conditions, PREDICT how the system and/or plant parameters will respond to the manipulations of the following controls. .6 Stuck Collet Assembly
Previous NRC Exam Use	None

K/A Reference(s)

<CM 241893(1002)><<B2.1.07>>	Safety Function 8	Tier 3	Group	RO Imp: 4.4	SRO Imp: 4.7
<CM 241893(1001)><<Ability to evaluate plant performance and make operational judgments based on operating characteristics, reactor behavior, and instrument interpretation. (CFR: 41.5 / 43.5 / 45.12 / 45.13)>>					
<CM 246491(1002)><<GS.201003>>	Safety Function 1	Tier 2	Group 2	RO Imp:	SRO Imp:
<CM 246491(1001)><<Control Rod and Drive Mechanism>>					

Learning Objective(s)

 <OB 1537873(1101)><<Q54 201003 2.1.7 (BH)>>
User (Sys) ID N/A (<OB 1537873(1125)><<1537873>>)

Cross Reference Links

None

Question 55	ID: 2151742	Points: 1.00
-------------	-------------	--------------

<QQ 2151742(1410)><<The plant is operating at rated thermal power (RTP).

THEN, a loss of the Rod Control & Information System (RCIS) Full Core Display occurred concurrently with a Reactor Scram.

- Scram reset has not been attempted.
- RCIS reset has not been attempted.

"All rods in" status is provided by the ____ (1) ____.

Specific control rod position of any rod not fully inserted is provided by the ____ (2) ____.>>

- A. <QQ 2151742(1480)><<(1) Plant Process Computer (PPC) OD-7
(2) Transient Test Channel 291>>
- B. <QQ 2151742(1480)><<(1) Plant Process Computer (PPC) OD-7
(2) Rod Action Control Cabinet (RACC) manual rod address LED ID matrix>>
- C. <QQ 2151742(1480)><<(1) Rod Action Control Cabinet (RACC) LED light ON
(2) Transient Test Channel 291>>
- D. <QQ 2151742(1480)><<(1) Rod Action Control Cabinet (RACC) LED light ON
(2) Rod Action Control Cabinet (RACC) manual rod address LED ID matrix>>

Answer	<QQ 2151742(1419)><<D>>
--------	-------------------------

Answer Explanation

<QQ 2151742(1412)><<D is correct.

Per CPS 3304.02 Rod Control & Information System (RC&IS), section 8.2.11 Alternate Means Of Determining Control Rod Positions:

- On either RACC panel 1H13-P651 or P652, determine if all rods are full in by observing the LED representing "all rods full in." This LED will be lit when all rods are fully inserted.
- Transient Test (TT) Channel 291 will indicate whether all rods are fully inserted. This indication is from Div 1 only; a value of 10 volts indicates rods full in, and a value of approximately 0 volts indicates all rods not full in.
- Rod position information is available on the process computer (OD-7), but valid rod positions cannot be determined until the SCRAM is reset.
- Use the following steps (1 - 3) in order to manually step the identification generator on either RACC panel 1H13-P651 or P652 through every rod address.
- Determine each rod position by analyzing the LED matrix on display card in RPIS file in 1H13-P651 or P652.

Incorrect Responses:

A is incorrect but plausible. This response would be correct if:

- the stem conditions indicated that the scram reset was complete, AND
- Transient Test Channel 291 provided specific control rod position information. This portion is plausible because while TT Channel 291 does indicate whether rods are fully inserted, it will not display specific control rod position.

B is incorrect but plausible. The first part of this response would be correct if the stem conditions indicated that the scram reset was complete. However, since the scram is not reset, the Plant Process Computer (PPC) OD-7 is unavailable to determine control rod position. The second part of this response is correct.

C is incorrect but plausible. The first part of this response is correct, but the second part is incorrect. This portion is plausible because while TT Channel 291 does indicate whether rods are fully inserted, it will not display specific control rod position.>>

Question Information

Topic	<QQ 2151742(1400)><<The plant is operating at rated thermal power (RTP). THEN, a loss of the Rod Control & Informati>>				
User ID	<QQ 2151742(1404)><<CL-ILT-N19055>>		System ID	<QQ 2151742(1445)><<2151742>>	
Status	<QQ 2151742(1405)><<Active>>	Point Value	<QQ 2151742(1441)><<1.00>>	Time (min)	<QQ 2151742(1408)><<0>>

Open or Closed Reference	<QQ 2151742(1409)><<CLOSED>>
Operator Type_Cognitive Level	<QQ 2151742(1415)><<RO-MEMORY>>
Operator Discipline	<QQ 2151742(1413)><<LO-I>>
10CFR55 Content	<TB 479395(1305)><<CFR: 41.10 Administrative, normal, abnormal, and emergency operating procedures for the facility.>>

References Provided	None
K/A Justification	Question meets the KA because the candidate must demonstrate the cause-effect relationship between RCIS and the RACCs when the RCIS full Core Display is unable to display control rod position information.
SRO-Only Justification	N/A
Additional Information	Question is low cog written at the memory level. The candidate must recall facts associated with the alternate means of determining control rod

	positions (1-l).
--	------------------

NRC Exams Only			
Question Type	New	Difficulty	N/A
Technical Reference and Revision #	<ul style="list-style-type: none"> • CPS 3304.02 Rev. 23 • CPS 4100.01 Rev. 23f 		
Training Objective	201002.03 DESCRIBE the function, operation, interlocks, trips, and power supplies of the following RC&IS System components. .7 Rod Action Control System		
Previous NRC Exam Use	None		

K/A Reference(s)

<input type="checkbox"/> <CM 235554(1002)><<201005.K1.05>>	Safety Function 1	Tier 2	Group 2	RO Imp: 3.5	SRO Imp: 3.5
<input type="checkbox"/> <CM 235549(1001)><<Knowledge of the physical connections and/or cause effect relationships between ROD CONTROL AND INFORMATION SYSTEM (RCIS) and the following: (CFR: 41.2 to 41.9 / 45.7 to 45.8)>> <input type="checkbox"/> <CM 235554(1001)><<Rod action control system: BWR-6>>					

Learning Objective(s)

<OB 1537874(1101)><<Q55 201005 K1.05 (NL)>>
 User (Sys) ID N/A (<OB 1537874(1125)><<1537874>>)

Cross Reference Links

None

Question 56	ID: 2152982	Points: 1.00
-------------	-------------	--------------

<QQ 2152982(1410)><<The plant is operating at rated thermal power (RTP).

THEN, a loss of Auxiliary Building (AB) Motor Control Center (MCC) 1G (1AP42E) occurs.

The ability to _____ is lost.>>

- A. <QQ 2152982(1480)><<isolate the "B" RR loop IAW CPS 3302.01 Reactor Recirculation (RR)>>
- B. <QQ 2152982(1480)><<start the Motor Driven Reactor Feed Pump (MDRFP) IAW CPS 3103.01 Feedwater (FW)>>
- C. <QQ 2152982(1480)><<initiate High Pressure Core Spray (HPCS) IAW CPS 3309.01 High Pressure Core Spray (HPCS)>>
- D. <QQ 2152982(1480)><<start Div 2 Diesel Generator (1DG01KB) IAW CPS 3506.01P001 Division 2 Diesel Generator Operations>>

Answer	<QQ 2152982(1419)><<A>>
--------	-------------------------

Answer Explanation

<QQ 2152982(1412)><<A is correct.

Per CPS 3302.01 Reactor Recirculation (RR) section 8.2.1 Loop Shutdown - during plant operation, the RX Recirc Pump B Disch Block Valve (1B33-F067B) is shut to isolate the 'B' loop.

Per CPS 3302.01 Reactor Recirculation Electrical Lineup, RX Recirc Pump B Disch Block Valve (1B33-F067B) is powered from AB MCC 1G (1AP42E).

With RX Recirc Pump B Disch Block Valve (1B33-F067B) deenergized, it cannot be repositioned and therefore, the capability to isolate the 'B' loop IAW CPS 3302.01 Reactor Recirculation (RR) is lost.

Incorrect Responses:

B is incorrect but plausible. This response would be correct if the Reactor Feed Pump 1C (MDRFP) Auxiliary Oil Pump (AOP) (1FW02P) was powered from AB MCC 1G (1AP42E). Per CPS 3514.01E006 4.16KV Bus 1B1 Outage Restoration Electrical Lineup, the MDRFP AOP is powered from TB MCC 1M (1AP71E).

C is incorrect but plausible. This response would be correct if the High Pressure Core Spray (HPCS) Water Leg Pump was powered from AB MCC 1G (1AP42E). Per CPS 3309.01E001 High Pressure Core Spray Electrical Lineup, the HPCS Water Leg pump (1E22-C003) is powered from Div 3 HPCS MCC 1C (1E22-S002).

D is incorrect but plausible. This response would be correct if the Diesel Gen 1B Starting Air Compressors (1DG02CA/B) and Diesel Gen Fuel Oil Transfer Pump 1B (1DO01PB) were powered from

AB MCC 1G (1AP42E). Per CPS 3506.01E001 Diesel Generator And Support Systems Electrical Lineup, the Diesel Gen 1B Starting Air Compressors (1DG02CA/B) and Diesel Gen Fuel Oil Transfer Pump 1B (1DO01PB) are powered from DG MCC 1B (1AP61E).>>

Question Information

Topic	<QQ 2152982(1400)><<The plant is operating at rated thermal power (RTP). THEN, a loss of Auxiliary Building (AB) Mot>>				
User ID	<QQ 2152982(1404)><<CL-ILT-N19056>>			System ID	<QQ 2152982(1445)>><<2152982>>
Status	<QQ 2152982(1405)>><<Active>>	Point Value	<QQ 2152982(1441)>><<1.00>>	Time (min)	<QQ 2152982(1408)>><<0>>

Open or Closed Reference	<QQ 2152982(1409)><<CLOSED>>
Operator Type_Cognitive Level	<QQ 2152982(1415)><<RO-MEMORY>>
Operator Discipline	<QQ 2152982(1413)><<LO-I>>
10CFR55 Content	<TB 479395(1305)><<CFR: 41.10 Administrative, normal, abnormal, and emergency operating procedures for the facility.>>

References Provided	None
K/A Justification	Question meets the KA because the candidate must demonstrate knowledge of electrical power supplies to Recirculation system valves to answer the question.
SRO-Only Justification	N/A
Additional Information	Question is low cog written at the memory level. The candidate must recall to which equipment MCC 1G supplies power (1-F).

NRC Exams Only			
Question Type	New	Difficulty	N/A
Technical Reference and Revision #	<ul style="list-style-type: none"> • CPS 3309.01E001 Rev. 8b • CPS 3506.01E001 Rev. 18d • CPS 3514.01E006 Rev. 5f • CPS 3514.01E021 Rev. 3 		
Training Objective	202001.03 DESCRIBE the function, operation, interlocks, trips, and power supplies of the following Reactor Recirculation System components. .4 Recirculation Pump Suction and Discharge Valves		

Previous NRC Exam Use	None
-----------------------	------

K/A Reference(s)

<CM 235766(1002)><<202001.K2.03>>	Safety Function 1	Tier 2	Group 2	RO Imp: 2.7*	SRO Imp: 2.8*
<CM 235763(1001)><<Knowledge of electrical power supplies to the following: (CFR: 41.7)>> <CM 235766(1001)><<Recirculation system valves>>					

Learning Objective(s)

 <OB 1537875(1101)><<Q56 202001 K2.03 (NL)>>
 User (Sys) ID N/A (<OB 1537875(1125)><<1537875>>)

Cross Reference Links

None

Question 57	ID: 2151562	Points: 1.00
-------------	-------------	--------------

<QQ 2151562(1410)><<The plant is operating at rated thermal power (RTP).

The Reactor Water Cleanup (RWCU) Non Regenerative Heat Exchanger (NRHX) High Outlet Temperature Instrument (1G33-N008) has failed low.

Which of the following RWCU valves, if open, would have an adverse effect on reactor water quality?>>

- A. <QQ 2151562(1480)><<Regen Hx Bypass Valve (1G33-F107)>>
- B. <QQ 2151562(1480)><<Drain Flow Orifice Bypass Valve (1G33-F031)>>
- C. <QQ 2151562(1480)><<Drain Flow Inboard Isolation Valve (1G33-F028)>>
- D. <QQ 2151562(1480)><<Regen Hx A/B Outlet Throttle Valve (1G33-F042A)>>

Answer	<QQ 2151562(1419)><<A>>
--------	-------------------------

Answer Explanation

<QQ 2151562(1412)><<A is correct.

Per CPS 5000.01 Alarm Panel 5000 Annunciators - Row 1 for 5000-1C F-D INLET TEMP HI 140°F:

- Potential Cause - Excessive opening of Regen Hx Bypass Valve (1G33-F107). 1G33-F107 is shut at rated thermal power.
- Temperature instrument 1G33-N008 initiates an isolation signal to the RWCU Suction Outboard Isolation Valve (1G33-F004).

Per CPS 3303.01 Reactor Water Cleanup (RT) Discussion/Limitations:

- RWCU maintains reactor water quality by removing soluble and insoluble impurities during all modes of Rx operations.
- RT F/D's shall be removed from service if NRHX outlet temperature exceeds 130°F. This will prevent damage to the ion exchange resins which can occur when F/D inlet temperature is ≥ 140°F.

Therefore:

- if 1G33-F107 is opened, NRHX Outlet temperature (Filter Demineralizer Inlet temperature) rises.
- since Temperature Instrument 1G33-N008 is failed low, there will be no isolation signal to 1G33-F004.
- as Filter Demineralizer (F/D) inlet temp rises >140°F:
 - F/D resin can breakdown and release collected contaminants
 - Reactor water quality could be adversely affected.

Incorrect Responses:

B is incorrect but plausible because it is in the flowpath for rejecting RT to the main condenser or Radwaste system. If opened, along with 1G33-F028 and 1G33-F034 (inboard and outboard drain isolation valves) and either 1G33-F035 (drain to Radwaste) or 1G33-F046 (drain to condenser), RT would be diverted from the reactor vessel, adversely affecting reactor water quality. However, both 1G33-F028 and 1G33-F034 are normally shut during system operation and would also need to be opened for this response to be correct.

C is incorrect but plausible because it is in the flowpath for rejecting RT to the main condenser or Radwaste system. If opened, along with 1G33-F034 (inboard drain isolation valve) and either 1G33-F035 (drain to Radwaste) or 1G33-F046 (drain to condenser), RT would be diverted from the reactor vessel, adversely affecting reactor water quality. However, 1G33-F034 is normally shut during system operation, and would also need to be opened for this response to be correct.

D is incorrect but plausible because 1G33-F042A is in the flowpath to the RT heat exchangers. However, 1G33-F042A is open at rated thermal power.>>

Question Information

Topic	<QQ 2151562(1400)><<The plant is operating at rated thermal power (RTP). The Reactor Water Cleanup (RWCU) Non Regene>>				
User ID	<QQ 2151562(1404)><<CL-ILT-N19057>>			System ID	<QQ 2151562(1445)><<2151562>>
Status	<QQ 2151562(1405)><<Active>>	Point Value	<QQ 2151562(1441)><<1.00>>	Time (min)	<QQ 2151562(1408)><<0>>

Open or Closed Reference	<QQ 2151562(1409)><<CLOSED>>
Operator Type_Cognitive Level	<QQ 2151562(1415)><<RO-HIGH>>
Operator Discipline	<QQ 2151562(1413)><<LO-I>>
10CFR55 Content	<TB 479395(1305)><<CFR: 41.10 Administrative, normal, abnormal, and emergency operating procedures for the facility.>>

References Provided	None
K/A Justification	Question meets the KA because the candidate must demonstrate knowledge of the effect that a RWCU malfunction will have on reactor water quality to answer the question.
SRO-Only Justification	N/A
Additional Information	Question is high cog written at the comprehension level. The candidate must recognize the interaction between RWCU (cooling), F/D and reactor water chemistry including the consequences and implications of RWCU valve

	manipulations to answer the question (2-RI).
--	--

NRC Exams Only			
Question Type	New	Difficulty	N/A
Technical Reference and Revision #	<ul style="list-style-type: none"> • CPS 3303.01 Rev. 38 • CPS 5000.01 (1C) Rev. 13a 		
Training Objective	204000.06 Given an RWCU System Annunciator, DESCRIBE: a. The condition causing the annunciator b. Any automatic actions c. Any operational implications		
Previous NRC Exam Use	None		

K/A Reference(s)

<CM 236085(1002)><<204000.K3.01>>	Safety Function 2	Tier 2	Group 2	RO Imp: 3.2	SRO Imp: 3.6
<CM 236084(1001)><<Knowledge of the effect that a loss or malfunction of the REACTOR WATER CLEANUP SYSTEM will have on following: (CFR: 41.7 / 45.4)>> <CM 236085(1001)><<Reactor water quality>>					

Learning Objective(s)

 <OB 1537876(1101)><<Q57 204000 K3.01 (NH)>>
 User (Sys) ID N/A (<OB 1537876(1125)><<1537876>>)

Cross Reference Links

None

Question 58	ID: 2157203	Points: 1.00
-------------	-------------	--------------

<QQ 2157203(1410)><<The plant is operating at rated thermal power (RTP).

THEN, a Loss of Off-site Power (LOOP) occurs concurrent with a Loss of Coolant Accident (LOCA).

At 1300, the following conditions are noted:

- RPV level is -56 inches and lowering at 2 inches/minute.
- Drywell pressure is 1.0 psig and rising at 1 psig/minute.
- Containment pressure is 0.8 psig and rising at 1 psig/minute.

(1) What is the earliest time that containment spray may be manually started?

During a Design Basis Accident (DBA) LOCA, ____ (2) ____ loop(s) of Containment Spray must be operated to lower containment pressure.>>

- A. <QQ 2157203(1480)><<(1) 1301
(2) one>>
- B. <QQ 2157203(1480)><<(1) 1301
(2) two>>
- C. <QQ 2157203(1480)><<(1) 1307
(2) one>>
- D. <QQ 2157203(1480)><<(1) 1307
(2) two>>

Answer	<QQ 2157203(1419)><<A>>
--------	-------------------------

Answer Explanation

<QQ 2157203(1412)><<A is correct.

Per CPS 5064.02 Alarm Panel 5064 Annunciators - Row 2, Annunciator 5064-2E Division 1 Containment Spray Activated, Containment Spray is initiated by either:

MANUAL

- S63A, CONTAINMENT SPRAY A(B) MANUAL A SHUTOFF VALVE, INITIATION pushbutton ARMED and DEPRESSED 1E12-F028A,
- with a High Drywell pressure (1.68 psig) red light ON (1B21-N694A or E).

AUTOMATIC (Following conditions exist concurrently)

- LPCI initiated for > 610 seconds.
- High Drywell pressure (1.68 psig) (1B21-N694A or E).
- High Containment pressure (22.3 psia) (1E12-N662A or C).
-

(psia - atmospheric pressure = psig; the high containment pressure setpoint is $22.3 - 14.7 = 7.6$ psig).

Since containment spray may be manually initiated once drywell pressure exceeds 1.68 psig, and at time 1301 drywell pressure would be 2.0 psig; time 1301 is the earliest time that containment spray may be manually initiated.

Per CPS USAR 6.2.2 Containment Heat Removal Systems (6.2.2.1 Design Bases):

- The containment heat removal system, consisting of the containment cooling system, is an integral part of the RHR system. The purpose of this system is to prevent excessive containment temperatures and pressures thus maintaining containment integrity following a LOCA. To aid in fulfilling this purpose, the containment cooling system meets the single failure criteria.

PER CPS USAR 7.3.2.4.3.1.2 Single Failure Criterion

- Redundancy in equipment and control logic circuitry is provided so that it is not possible that the complete containment spray mode can be rendered inoperative using single failure criteria.
- Two division logics are provided. Division 1 logic is provided to initiate loop A equipment and Division 2 logic is provided to initiate loop B equipment.
- Tolerance to single failures in accordance with IEEE 379 is provided in the sensing channels, trip logic, actuator logic, and actuated equipment so that a single failure will be limited to the possible disabling of only one loop.

Therefore, there are two redundant, 100% capacity RHR containment spray subsystems and in the event of a Design Basis Accident (DBA) , a minimum of one RHR containment spray subsystem is required to maintain the primary containment peak pressure below design limits.

Incorrect Responses:

B is incorrect but plausible. The first part of the response is correct. The second part of the response is plausible because with two RHR containment spray subsystems, it would be reasonable to assume that each one was only 50% capacity. Per NUREG 1021 Appendix A, the purpose of the written examination is to differentiate between competent and less-than-competent applicants, and ECCS system redundancy is a concept essential to reactor safety and plant operations that competent novice applicants must understand.

C is incorrect but plausible. The first part of the response is plausible because containment pressure is one of three conditions that must be exceeded for automatic initiation of containment spray and would be exceeded at time 1307. However, drywell pressure is the condition required to be satisfied to manually initiate containment spray, not containment pressure. The second part of the response is correct.

D is incorrect but plausible. This response is plausible because:

- containment pressure is one of three conditions that must be exceeded for automatic initiation of containment spray and would be exceeded at time 1307, AND
- with two RHR containment spray subsystems, it would be reasonable to assume that each one was only 50% capacity.>>

Question Information

Topic	<QQ 2157203(1400)><<The plant is operating at rated thermal power (RTP). THEN, a Loss of Off-site Power (LOOP) occur>>				
User ID	<QQ 2157203(1404)><<CL-ILT-N19058>>		System ID	<QQ 2157203(1445)><<2157203>>	
Status	<QQ 2157203(1405)><<Active>>	Point Value	<QQ 2157203(1441)><<1.00>>	Time (min)	<QQ 2157203(1408)><<0>>

Open or Closed Reference	<QQ 2157203(1409)><<CLOSED>>
Operator Type_Cognitive Level	<QQ 2157203(1415)><<RO-HIGH>>
Operator Discipline	<QQ 2157203(1413)><<LO-I>>
10CFR55 Content	<TB 479395(1305)><<CFR: 41.10 Administrative, normal, abnormal, and emergency operating procedures for the facility.>>

References Provided	None
K/A Justification	Question meets the KA because the candidate must demonstrate knowledge of RHR Containment Spray System Mode redundancy to answer the question.
SRO-Only Justification	N/A
Additional Information	Question is high cog written at the analysis & comprehension level. The candidate must analyze the conditions provided in the stem and then determine when an event will happen by applying knowledge of the Containment Spray System to answer the question (3-SPK).

NRC Exams Only			
Question Type	New	Difficulty	N/A
Technical Reference and Revision #	<ul style="list-style-type: none"> • CPS USAR 6.2.2 Rev. 14 • CPS USAR 7.3.2.4.3.1.2 Rev. 11 • CPS 5064.02 Rev. 32 		
Training Objective	203000.15 Given RESIDUAL HEAT REMOVAL System initial conditions, PREDICT how the system and/or plant parameters will respond to the manipulation of the following controls. .2 From Standby, Arming/Depressing Div 1(2) Manual Containment Spray Initiation Pushbutton		
Previous NRC Exam Use	None		

K/A Reference(s)

<CM 237881(1002)><<226001.K4.02>>	Safety Function 5	Tier 2	Group 2	RO Imp: 2.8	SRO Imp: 2.9
<CM 237879(1001)><<Knowledge of RHR/LPCI: CONTAINMENT SPRAY SYSTEM MODE design feature(s) and/or interlocks which provide for the following: (CFR: 41.7)>> <CM 237881(1001)><<Redundancy>>					

Learning Objective(s)

 <OB 1537877(1101)><<Q58 226001 K4.02 (NH)>>
 User (Sys) ID N/A (<OB 1537877(1125)><<1537877>>)

Cross Reference Links

None

Question 59	ID: 2166795	Points: 1.00
-------------	-------------	--------------

<QQ 2166795(1410)><<The plant is in a Refueling Outage moving irradiated fuel in the Spent Fuel Pool. The fuel handling operator has a spent fuel bundle on the grapple.

THEN, the following annunciators were received:

- 5040-3F Low-Low Level Spent Fuel Storage Pool
- 1RIX-AR016 Spent Fuel Storage FB 755' AH-117 High Alarm (all channels indicate 3 mr/hr and are slowly trending up).
- Fuel Building Exhaust Rad Monitors (1RIX-PR006A-D) indicate 7 mr/hr and are slowly trending up.

Immediate evacuation of the fuel pool area ____ (1) ____ required.

An EOP-8, Secondary Containment Control entry condition ____ (2) ____.>>

- A. <QQ 2166795(1480)><<(1) is (2) exists>>
- B. <QQ 2166795(1480)><<(1) is (2) does NOT exist>>
- C. <QQ 2166795(1480)><<(1) is NOT (2) exists>>
- D. <QQ 2166795(1480)><<(1) is NOT (2) does NOT exist>>

Answer	<QQ 2166795(1419)><<A>>
--------	-------------------------

Answer Explanation

<QQ 2166795(1412)><<A is correct:

Lowering of the fuel pool water level decreases the available shielding (water) and increases radiation exposure to personnel in the Fuel Building (FB).

- Per CPS 4011.02 Spent Fuel Pool Abnormal Water Level Decrease, an abnormal water level decrease in the spent fuel pools requires an immediate evacuation of the spent fuel pool area after placing any suspended fuel/core components in a safe condition.
- Per CPS 4406.01 EOP-8 Secondary Containment Control, any Table U area radiation level above max normal is an entry condition for EOP-8 Secondary Containment Control. Additionally, CPS 5040.03 ALARM PANEL 5040 ANNUNCIATORS - ROW 3 (3F) directs EOP-8 entry.

Therefore, an evacuation of the spent fuel pool area is required and an EOP-8 entry condition does exist.

Incorrect Responses:

B is incorrect but plausible. The first part of the answer is correct. The second part is plausible based on the PR006A - D readings being an EOP-8 entry condition at 10mr/hr.

C is incorrect but plausible since CPS 4979.02 Abnormal High Area Radation Levels contains a subsequent action to evaluate the need for evacuations (blocking access to the spent fuel pool) prior to level approaching the top of irradiated fuel OR, level cannot be restored OR, high radiation levels existing. The second part is correct.

D is incorrect but plausible since CPS 4979.02 Abnormal High Area Radation Levels contains a subsequent action to evaluate the need for evacuations (blocking access to the spent fuel pool) prior to level approaching the top of irradiated fuel OR, level cannot be restored OR, high radiation levels existing. The second part is plausible based on the PR006A - D readings being an EOP-8 entry condition at 10mr/hr.>>

Question Information

Topic	<QQ 2166795(1400)><<The plant is in a Refueling Outage moving irradiated fuel in the Spent Fuel Pool. The fuel handlin>>				
User ID	<QQ 2166795(1404)><<CL-ILT-N19059>>			System ID	<QQ 2166795(1445)>><<2166795>>
Status	<QQ 2166795(1405)>><<Active>>	Point Value	<QQ 2166795(1441)>><<1.00>>	Time (min)	<QQ 2166795(1408)>><<0>>

Open or Closed Reference	<QQ 2166795(1409)><<CLOSED>>
Operator Type_Cognitive Level	<QQ 2166795(1415)><<RO-HIGH>>
Operator Discipline	<QQ 2166795(1413)><<LO-I>>
10CFR55 Content	<TB 479395(1305)><<CFR: 41.10 Administrative, normal, abnormal, and emergency operating procedures for the facility.>>

References Provided	None
K/A Justification	Question meets the KA because the candidate must demonstrate knowledge of the operational implications of a loss of spent fuel pool level (water as a shield against radiation) as they apply to Fuel Handling Equipment in use to answer the question.
SRO-Only Justification	N/A
Additional Information	Question is high cog written at the analysis & comprehension level. The candidate must analyze the conditions provided during a fuel handling evolution and then determine the appropriate mitigating actions to answer the question (3-SPK/SPR).

NRC Exams Only			
Question Type	Bank (CL-ILT-A12021)	Difficulty	N/A
Technical Reference and Revision #	<ul style="list-style-type: none"> • CPS 4011.02 Rev. 7d • CPS 4001.02C001 Rev. 16c • CPS 4406.01 Rev. 30 • CPS 5040.04 (3F) Rev. 26d 		
Training Objective	PB401102.01.03 Describe the major concerns with a decreased water level in the Spent Fuel Pool.		
Previous NRC Exam Use	None		

K/A Reference(s)

<CM 238162(1002)><<234000.K5.03>>	Safety Function 8	Tier 2	Group 2	RO Imp: 2.9	SRO Imp: 3.4
<CM 238159(1001)><<Knowledge of the operational implications of the following concepts as they apply to FUEL HANDLING EQUIPMENT : (CFR: 41.5 / 45.3)>> <CM 238162(1001)><<†Water as a shield against radiation>>					

Learning Objective(s)

 <OB 1537878(1101)><<Q59 234000 K5.03 (BH)>>
 User (Sys) ID N/A (<OB 1537878(1125)><<1537878>>)

Cross Reference Links

Table: <TB 775424(1301)><<TRAINING - QUESTIONS - Track Questions Modified in this Project (CL-OPS-EXAM-ILT)>>
<TB 776624(1305)><<Tracking link in project CL-OPS-EXAM-ILT to source question 2151508>>

Question 60

ID: 2151507

Points: 1.00

<QQ 2151507(1410)><<The plant is at 55% rated thermal power.

THEN, the Main Turbine to Main Condenser seal boot ruptures. Main Condenser Vacuum begins to LOWER (degrade).

Given the graph below and assuming NO operator action, at what time will Main Condenser Vacuum lower to the point that the Main Steam Isolation Valves (MSIVs) will automatically close?

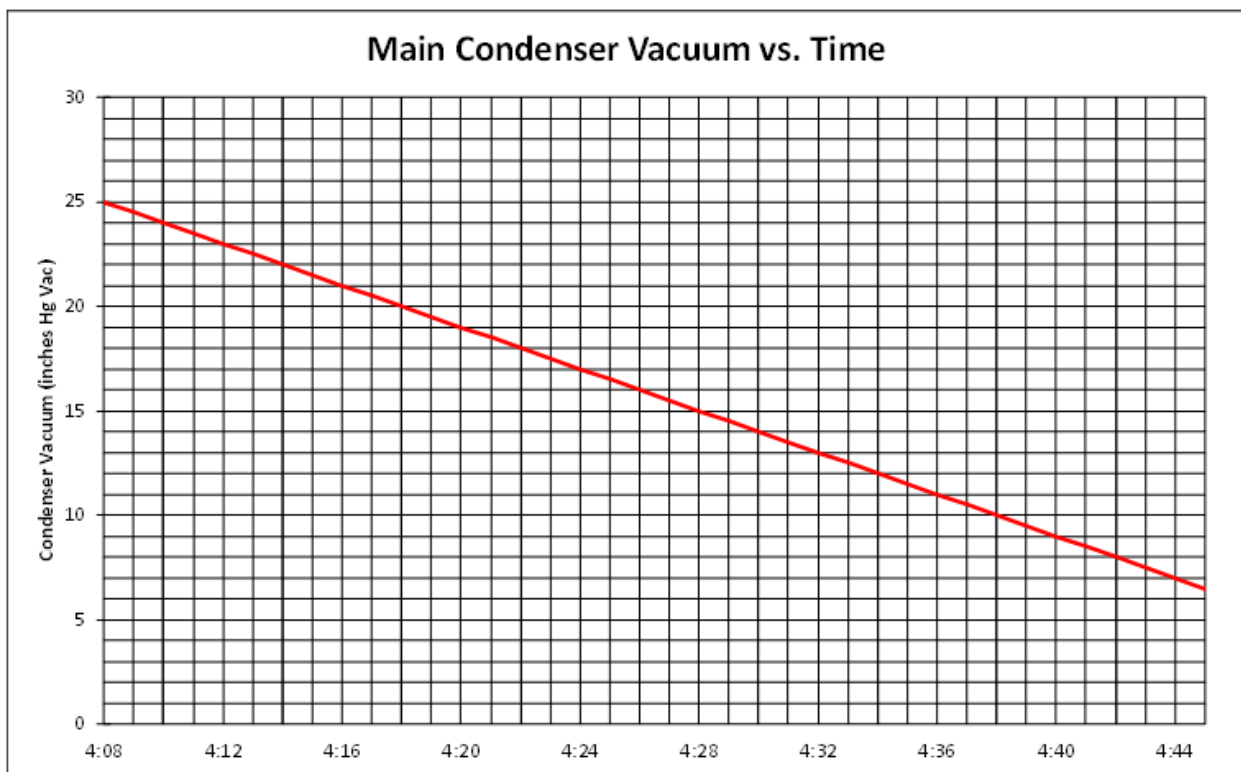

>>

- A. <QQ 2151507(1480)><<4:10>>
- B. <QQ 2151507(1480)><<4:15>>
- C. <QQ 2151507(1480)><<4:21>>
- D. <QQ 2151507(1480)><<4:41>>

Answer	<QQ 2151507(1419)><<D>>
--------	-------------------------

Answer Explanation

<QQ 2151507(1412)><<D is correct: Per CPS 3112.01 Condenser Vacuum (CA), the following events occur when vacuum is broken (i.e. lowering Main Condenser Vacuum):

- Main Turbine Trip - 21.6 " Hg vac
- Rx Feed Pump Turbine Trip - 18.5 " Hg vac
- Group 1 Isolation - 8.5" Hg vac
- Bypass Valve Inhibit - 7.5" Hg vac

Per CPS 4001.02C001 Automatic Isolation Checklist, a Group #1 isolation includes Main Steam Line Inboard MSIVs (1B21-F022A-D) and Outboard MSIVs (1B21-F028A-D).

Using the graph provided in the question stem, 8.5" Hg vac corresponds to a time of 4:41.

Incorrect Responses:

A is incorrect but plausible. This answer would be correct if 24" Hg vacuum is the point at which a Group #1 isolation occurs. Per CPS 3105.01 Turbine (TG, EHC, TS) the turbine should not be operated above 1200 rpm with a condenser vacuum < 24" Hg vac. Using the graph provided in the question stem, 24" Hg vac corresponds to a time of 4:10.

B is incorrect but plausible. This answer would be correct if 21.6" Hg vacuum is the point at which a Group #1 isolation occurs. Per CPS 3112.01 Condenser Vacuum (CA) a Main Turbine Trip will occur at 21.6" Hg vac. Using the graph provided in the question stem, 21.6" Hg vac corresponds to a time of 4:15.

C is incorrect but plausible. This answer would be correct if 18.5" Hg vacuum is the point at which a Group #1 isolation occurs. Per CPS 3112.01 Condenser Vacuum (CA) a Rx Feed Pump Turbine Trip will occur at 18.5" Hg vac. Using the graph provided in the question stem, 18.5" Hg vac corresponds to a time of 4:21.>>

Question Information

Topic	<QQ 2151507(1400)><<The plant is at 55% rated thermal power. THEN, the Main Turbine to Main Condenser seal boot rupt>>				
User ID	<QQ 2151507(1404)><<CL-ILT-N19060>>		System ID	<QQ 2151507(1445)><<2151507>>	
Status	<QQ 2151507(1405)><<Active>>	Point Value	<QQ 2151507(1441)><<1.00>>	Time (min)	<QQ 2151507(1408)><<0>>

Open or Closed Reference	<QQ 2151507(1409)><<CLOSED>>
Operator Type_Cognitive Level	<QQ 2151507(1415)><<RO-HIGH>>
Operator Discipline	<QQ 2151507(1413)><<LO-I>>
10CFR55 Content	<TB 479392(1305)><<CFR: 41.7 Design, components, and functions of control and safety systems, including instrumentation, signals, interlocks, failure modes, and automatic and manual features.>>

References Provided	None
K/A Justification	Question meets the KA because the candidate must demonstrate knowledge of the effect that a loss or malfunction of Main condenser vacuum will have on the Main And Reheat Steam System to answer the question.
SRO-Only Justification	N/A
Additional Information	Question is high cog written at the comprehension level. The candidate must recognize the relationship between the main condenser (vacuum) and the Main Steam System (MSIVs) and then determine when an event will take place using a graph pertinent to that relationship (2-DR).

NRC Exams Only			
Question Type	Bank (CL-ILT-N15054)	Difficulty	N/A
Technical Reference and Revision #	<ul style="list-style-type: none"> • CPS 3112.01 Rev. 21c • CPS 4001.02C001 Rev. 16c • CPS 3105.01 Rev. 44b 		
Training Objective	239001.03 DESCRIBE the function, operation, interlocks, trips, and power supplies of the following MAIN STEAM System components. .5 Main Steam Isolation Valves		
Previous NRC Exam Use	ILT 15-1 NRC		

K/A Reference(s)

<CM 238297(1002)><<239001.K6.08>>	Safety Function 3	Tier 2	Group 2	RO Imp: 3.3	SRO Imp: 3.4
<CM 238289(1001)><<Knowledge of the effect that a loss or malfunction of the following will have on the MAIN AND REHEAT STEAM SYSTEM: (CFR: 41.7 / 45.7)>> <CM 238297(1001)><<Main condenser vacuum>>					

Learning Objective(s)

 <OB 1537879(1101)><<Q60 239001 K6.08 (BH)>>
 User (Sys) ID N/A (<OB 1537879(1125)><<1537879>>)

Cross Reference Links

None

Question 61	ID: 2151470	Points: 1.00
-------------	-------------	--------------

<QQ 2151470(1410)><<The plant is operating at rated thermal power.

The Steam Bypass and Pressure Control System controls are as follows:

- The LOAD LIMIT SET potentiometer is set at the 100% position.
- The Steam Flow Demand signal being produced by the Pressure Regulator is 80%.

THEN, a Steam Bypass and Pressure Control System electronic malfunction occurs.

- The LOAD LIMIT SET setpoint slowly lowers to a new value of 70%.

NO operator actions have been taken.

Which of the following describes the expected plant response?>>

- A. <QQ 2151470(1480)><<Generator load will remain at 80%.>>
- B. <QQ 2151470(1480)><<RPV water level will swell to Level 8.>>
- C. <QQ 2151470(1480)><<Reactor pressure will rise until a SRV opens to limit pressure.>>
- D. <QQ 2151470(1480)><<Reactor power will rise and stabilize approximately 1% higher.>>

Answer	<QQ 2151470(1419)><<D>>
--------	-------------------------

Answer Explanation

<QQ 2151470(1412)><<D is correct.

Per N-CL-OPS-241001 STEAM BYPASS AND PRESSURE CONTROL, Exceeding the LOAD LIMIT SET:

- If the STEAM FLOW DEMAND exceeds the LOAD LIMIT SET, the LOAD LIMIT SET will become the lower value going into the LVG and will limit Main Turbine load to its value.
- The STEAM FLOW DEMAND signal now exceeds the CONTROL VALVE FLOW REFERENCE at the Bypass Valve Summer and the Bypass Valves will open to pass the excess steam flow.

At rated power, LOAD LIMIT SET setpoint is 100%. After the malfunction occurs, the new setpoint is 70%. Steam Flow Demand signal now exceeds the Control Valve Flow Reference signal by 10% (80% steam flow – 70% = 10%).

Approximately 2 Turbine Bypass Valves (TBVs) will open to pass the excess steam to the condenser. The plant will stabilize with:

- a reduced generator load (about 10% less load).
- a higher reactor power (about 1% due to steam flow bypasses feedwater heating).

- a minimal pressure transient resulting in normal (approximately initial) reactor pressure.

Any RPV level transient that may actually occur during the minimal (if any noticeable) pressure transient will be corrected by the Feedwater Level Control System.

Incorrect Responses:

A is incorrect but plausible. The response is plausible because there is no change to reactor power given in the stem. Normally, with no change to reactor power, main turbine load will not change. However, as the turbine bypass valves (TBVs) open the turbine control valves (TCVs) will close. This will result in a reduction of generator load.

B is incorrect but plausible. The response is plausible because a step change reduction in steam demand could cause a significant perturbation in feedwater system and RPV level. However, as the turbine bypass valves (TBVs) open the turbine control valves (TCVs) will close minimizing the perturbation ensuring the transient is within the capabilities of the Feedwater Level Control System.

C is incorrect but plausible. The response is plausible because the pressure regulator subsystem normally causes reactor pressure to raise in response to a rising reactor power. However, the turbine bypass valves (TBVs) and turbine control valves (TCVs) will act to maintain reactor pressure relatively constant during the transient.>>

Question Information

Topic	<QQ 2151470(1400)><<The plant is operating at rated thermal power. The Steam Bypass and Pressure Control System con>>				
User ID	<QQ 2151470(1404)><<CL-ILT-N19061>>			System ID	<QQ 2151470(1445)><<2151470>>
Status	<QQ 2151470(1405)><<Active>>	Point Value	<QQ 2151470(1441)><<1.00>>	Time (min)	<QQ 2151470(1408)><<0>>

Open or Closed Reference	<QQ 2151470(1409)><<CLOSED>>
Operator Type_Cognitive Level	<QQ 2151470(1415)><<RO-HIGH>>
Operator Discipline	<QQ 2151470(1413)><<LO-I>>
10CFR55 Content	<TB 479395(1305)><<CFR: 41.10 Administrative, normal, abnormal, and emergency operating procedures for the facility.>>

References Provided	None
K/A Justification	Question meets the KA because the candidate must predict the change in parameters (including Reactor Power) when the reactor/turbine pressure regulating system responds to a change in load

	limit set.
SRO-Only Justification	N/A
Additional Information	Question is high cog written at the application and analysis level. The candidate must evaluate plant conditions presented in the stem and then predict the plant response. (3-PEO)

NRC Exams Only			
Question Type	New	Difficulty	N/A
Technical Reference and Revision #	<ul style="list-style-type: none"> N-CL-OPS-241001 Rev. 4 		
Training Objective	241001.16 EVALUATE the following Steam Bypass & Pressure Control indications/responses and DETERMINE if the indication/ response is expected and normal.		
Previous NRC Exam Use	None		

K/A Reference(s)

<CM 238454(1002)><<241000.A1.02>>	Safety Function 3	Tier 2	Group 2	RO Imp: 4.1*	SRO Imp: 3.9
<CM 238452(1001)><<Ability to predict and/or monitor changes in parameters associated with operating the REACTOR/TURBINE PRESSURE REGULATING SYSTEM controls including: (CFR: 41.5 / 45.5)>> <CM 238454(1001)><<Reactor power>>					

Learning Objective(s)

 <OB 1537880(1101)><<Q61 241000 A1.02 (NH)>>
 User (Sys) ID N/A (<OB 1537880(1125)><<1537880>>)

Cross Reference Links

None

Question 62

ID: 2167185

Points: 1.00

<QQ 2167185(1410)><<The unit is operating at rated thermal power.

Which of the following describes the impact of a loss of 6.9 KV Bus 1B?>>

- A. <QQ 2167185(1480)><<Diesel Fire Pump 1B will NOT run.>>
- B. <QQ 2167185(1480)><<125VDC Battery Charger 1F will be lost.>>
- C. <QQ 2167185(1480)><<ONLY ONE Circulating Water Pump will run.>>
- D. <QQ 2167185(1480)><<Motor-Driven Reactor Feedwater Pump (MDRFP) will NOT run.>>

Answer

<QQ 2167185(1419)><<D>>

Answer Explanation

<QQ 2167185(1412)><<D is correct.

Per CPS 3514.01C002, 6900V Bus 1B (1AP05E) Outage, step 2.1.3, 1FW01PC Rx Feed Pump 1C is powered from 6900V Bus 1B, and will not run if power is unavailable from 6.9 KV Bus 1B.

Incorrect Responses:

A is incorrect but plausible. A loss of 6.9 KV Bus 1B will impact the 'B' Diesel Fire Pump but will not prevent it from running as stated in the distracter. Per CPS 4200.01 step 2.2.5, if 6900V 1A or 1B busses are de-energized, their respective Diesel Fire Pumps, 0FP01PA(B) will start.

B is incorrect but plausible. Per CPS 3514.01C013 480V Unit Sub 1E (1AP15E) Bus Outage, step 2.1.4. 125VDC Battery Charger 1F is powered from 480V Unit Sub 1E which is powered from 6900V Bus 1B. On a 6900V Bus 1B undervoltage condition, however, the 480V Bus 1D & 1E Tie Bkr 1AP14E will automatically close, preventing loss of power to 480V Unit Sub 1E.

C is incorrect but plausible. Per CPS 3113.01E001, the Circulating Water Pumps are powered from 6900 V Bus 1A and 1B. Two CW Pumps (A and C) are powered from 6900 V Bus 1A, and one CW Pump (B) is powered from 6900 V Bus 1B. Therefore, two Circulating Water Pumps would remain available with a loss of 6900 V Bus 1B.>>

Question Information

Topic	<QQ 2167185(1400)><<The unit is operating at rated thermal power. Which of the following describes the impact of a l>>				
User ID	<QQ 2167185(1404)><<CL-ILT-N19062>>			System ID	<QQ 2167185(1445)><<2167185>>
Status	<QQ 2167185(1405)><<Active>>	Point Value	<QQ 2167185(1441)><<1.00>>	Time (min)	<QQ 2167185(1408)><<0>>

Open or Closed Reference	<QQ 2167185(1409)><<CLOSED>>
Operator Type_Cognitive Level	<QQ 2167185(1415)><<RO-MEMORY>>
Operator Discipline	<QQ 2167185(1413)><<LO-I>>
10CFR55 Content	<TB 479390(1305)><<CFR: 41.5 Facility operating characteristics during steady state and transient conditions, including coolant chemistry, causes and effects of temperature, pressure and reactivity changes, effects of load changes, and operating limitations and reasons for these operating characteristics.>>

References Provided	None
K/A Justification	Question meets the KA because the examinee has to demonstrate knowledge of the electrical power supply to the Motor Driven Reactor Feedwater Pump to answer the question.
SRO-Only Justification	N/A
Additional Information	Question is low cog written at the memory level. The candidate must recall the power source to the MDRFP to answer the question (1-F).

NRC Exams Only			
Question Type	Bank (CL-ILT-N17035)	Difficulty	N/A
Technical Reference and Revision #	<ul style="list-style-type: none"> • CPS 3514.01C002 Rev. 3a • CPS 4200.01 Rev. 26 • CPS 3514.01C013 Rev. 4d • CPS 3113.01E001 Rev. 11a 		
Training Objective	259001.03 DESCRIBE the function, operation, interlocks, trips, and power supplies of the following FEEDWATER System components. .5 Motor Driven Feed Pump		
Previous NRC Exam Use	ILT 17-1 NRC		

K/A Reference(s)

<CM 238970(1002)><<259001.K2.01>>	Safety Function 2	Tier 2	Group 2	RO Imp: 3.3	SRO Imp: 3.3
<CM 238969(1001)><<Knowledge of electrical power supplies to the following: (CFR: 41.7)>> <CM 238970(1001)><<Reactor feedwater pump(s): Motor-Driven-Only>>					

Learning Objective(s)

 <OB 1537881(1101)><<Q62 259001 A2.08(PL)>>
 User (Sys) ID N/A (<OB 1537881(1125)><<1537881>>)

Cross Reference Links

Table: <TB 775424(1301)><<TRAINING - QUESTIONS - Track Questions Modified in this Project (CL-OPS-EXAM-ILT)>>
<TB 776744(1305)><<Tracking link in project CL-OPS-EXAM-ILT to source question 2150602>>

Question 63

ID: 2151390

Points: 1.00

<QQ 2151390(1410)><<A plant heatup and pressurization is in progress with conditions as follows:

- Condenser vacuum has been established.
- Main Steam Isolation Valves (MSIVs) are open.
- SJAЕ warmup is in progress.
- Main Steam Line Rad Monitor Computer Points:
 - D17DA001 (MSL Radiation A) - 11 mr/hr (1000 mr/hr @ RTP)
 - D17DA004 (MSL Radiation D) - 31 mr/hr (1020 mr/hr @ RTP)

THEN, a transient occurs causing the Main Steam Line Rad Monitor Computer Points to indicate as follows:

- D17DA001 (MSL Radiation A) - 3030 mr/hr
- D17DA004 (MSL Radiation D) - 3090 mr/hr

GIVEN:

- 5067-3E MAIN STEAM LINE DIV 1,4 RADN HIGH-HIGH OR INOP
- 5067-3F MAIN STEAM LINE RADIATION HIGH

Annunciator(s) ____ (1) ____ should be in alarm.

Assuming NO automatic actions took place, the next required operator action is to ____ (2) ____.>>

- A. <QQ 2151390(1480)><<(1) 5067-3F only
(2) initiate a Group 1 isolation>>
- B. <QQ 2151390(1480)><<(1) 5067-3E and 5067-3F
(2) initiate a Group 1 isolation>>
- C. <QQ 2151390(1480)><<(1) 5067-3F only
(2) secure the operating mechanical vacuum pump(s)>>
- D. <QQ 2151390(1480)><<(1) 5067-3E and 5067-3F
(2) secure the operating mechanical vacuum pump(s)>>

Answer	<QQ 2151390(1419)><<D>>
--------	-------------------------

Answer Explanation

<QQ 2151390(1412)><<D is correct.

Given that Main Steam Line Rad Monitor Computer Points are both > than 3X full power background:

- D17DA001 (MSL Radiation A) - 3030 mr/hr (> 3 X 1000 = 3000 mr/hr)

- D17DA004 (MSL Radiation D) - 3090 mr/hr ($> 3 \times 1020 = 3060$ mr/hr)

And Main Steam Line Radiation annunciators have exceeded their setpoints;

- 5067-3E MAIN STEAM LINE DIV 1,4 RADN HIGH-HIGH OR INOP (3 X full power background - double the 5067-3F setpoint)
- 5067-3F MAIN STEAM LINE RADIATION HIGH (1.5 X full power background)

BOTH annunciators should be in alarm.

Per CPS 5067.03 (3E), a trip of the Div 1 & 4 MSL Rad Monitors will cause a trip of the Mechanical Vacuum Pumps. However, no automatic actions took place. Per OP-CL-111-1001 Strategies For Successful Transient Mitigation, 2. Manual Action in lieu of Automatic Action, "When automatic actions fail to occur as designed operators are expected to place the system or component in the desired state...". Therefore, the 'B' RO should secure the operating mechanical vacuum pump(s).

Incorrect Responses:

A is incorrect but plausible. The first part of this response is partially correct. While annunciator 5067-3F MAIN STEAM LINE RADIATION HIGH is $>1.5X$ full power background and in alarm, annunciator 5067-3E MAIN STEAM LINE DIV 1,4 RADN HIGH-HIGH OR INOP should also be in alarm. This is plausible due to the misconception that the setpoint for annunciator 5067-3E has not yet been reached. The second part of is plausible because a MSL High Radiation condition did once cause a Group 1 Isolation. Per ORM 2.2.16 MSLRM Instrumentation Bases 5.2.16, the MSLR CRVICS isolation and RPS Scram functions were removed from the Technical Specifications based on the applicability of General Electric Topical Report NEDO-31400A, "Safety Evaluation for Eliminating the Boiling Water Reactor Main Steam Line Radiation Monitor," for CPS. Therefore, a MSL High Radiation condition no longer causes a Group 1 Isolation. Per CPS 4010.01, step 4.3, a manual Group 1 isolation is required to be performed if annunciator 5067-3E is in alarm.

B is incorrect but plausible. The first part of the response is correct. The second part would be correct if a MSL High Radiation conditions still caused a Group 1 Isolation. Per ORM 2.2.16 MSLRM Instrumentation Bases 5.2.16, the MSLR CRVICS isolation and RPS Scram functions were removed from the Technical Specifications based on the applicability of General Electric Topical Report NEDO-31400A, "Safety Evaluation for Eliminating the Boiling Water Reactor Main Steam Line Radiation Monitor," for CPS. Therefore, a MSL High Radiation condition no longer causes a Group 1 Isolation. Taking manual action to perform an automatic function that did not occur is the priority.

C is incorrect but plausible. The first part of this response is partially correct. While annunciator 5067-3F MAIN STEAM LINE RADIATION HIGH is $>1.5X$ full power background and in alarm, annunciator 5067-3E MAIN STEAM LINE DIV 1,4 RADN HIGH-HIGH OR INOP should also be in alarm. This is plausible due to the misconception that the setpoint for annunciator 5067-3E has not yet been reached.>>

Question Information

Topic	<QQ 2151390(1400)><<A plant heatup and pressurization is in progress with conditions as follows: Condenser vacuum has >>				
User ID	<QQ 2151390(1404)><<CL-ILT-N19063>>			System ID	<QQ 2151390(1445)><<2151390>>
Status	<QQ 2151390(1405)><<Active>>	Point Value	<QQ 2151390(1441)><<1.00>>	Time (min)	<QQ 2151390(1408)><<0>>

Open or Closed Reference	<QQ 2151390(1409)><<CLOSED>>
Operator Type_Cognitive Level	<QQ 2151390(1415)><<RO-HIGH>>
Operator Discipline	<QQ 2151390(1413)><<LO-I>>
10CFR55 Content	<TB 479395(1305)><<CFR: 41.10 Administrative, normal, abnormal, and emergency operating procedures for the facility.>>

References Provided	None
K/A Justification	Question meets the KA because the conditions presented in the stem are indicative of a fuel element failure requiring the candidate to predict the expected radiation monitor response and then select the correct mitigating action that should have occurred and which the B 'RO' would take.
SRO-Only Justification	N/A
Additional Information	This is a high cog question written at the analysis and application level. The candidate must analyze the parameters in stem, predict a response and then determine the expected automatic operations based on the analysis (3-PEO/SPK).

NRC Exams Only			
Question Type	New	Difficulty	N/A
Technical Reference and Revision #	<ul style="list-style-type: none"> ORM 2.2.16 (p. 35) Rev. 89 CPS 5067.03 (3E/3F) Rev. 32c OP-CL-101-111-1001 Rev. 15d 		
Training Objective	272000.08 Given the AR/PR system, DESCRIBE the systems supported and the nature of the support .1 Condenser Air Removal (CA) System		
Previous NRC Exam Use	None		

K/A Reference(s)

<CM 239616(1002)><<272000.A2.01>>	Safety Function 7	Tier 2	Group 2	RO Imp: 3.7	SRO Imp: 4.1
<CM 239615(1001)><<Ability to (d) predict the impacts of the following on the RADIATION MONITORING SYSTEM ; and (b) based on those predictions, use procedures to correct, control, or mitigate the consequences of those abnormal conditions or operations: (CFR: 41.5 / 45.6)>> <CM 239616(1001)><<Fuel element failure>>					

Learning Objective(s)

 <OB 1537882(1101)><<Q63 272000 A2.01 (NH)>>
 User (Sys) ID N/A (<OB 1537882(1125)><<1537882>>)

Cross Reference Links

None

Question 64	ID: 2106964	Points: 1.00
-------------	-------------	--------------

<QQ 2106964(1410)><<The plant was operating at rated thermal power.

THEN, the following alarms were received:

- 1RIX-PR006A, 6B, 6C, and 6D FB Exhaust Radiation monitor tiles are Red.

NO other Rad Monitor alarms are present.

Which of the following cases show the expected status of 1VR006A Containment Building Supply Outboard Isolation Valve and 1VF04Y/9Y Fuel Building Supply/Exhaust Outboard Isolation Dampers?

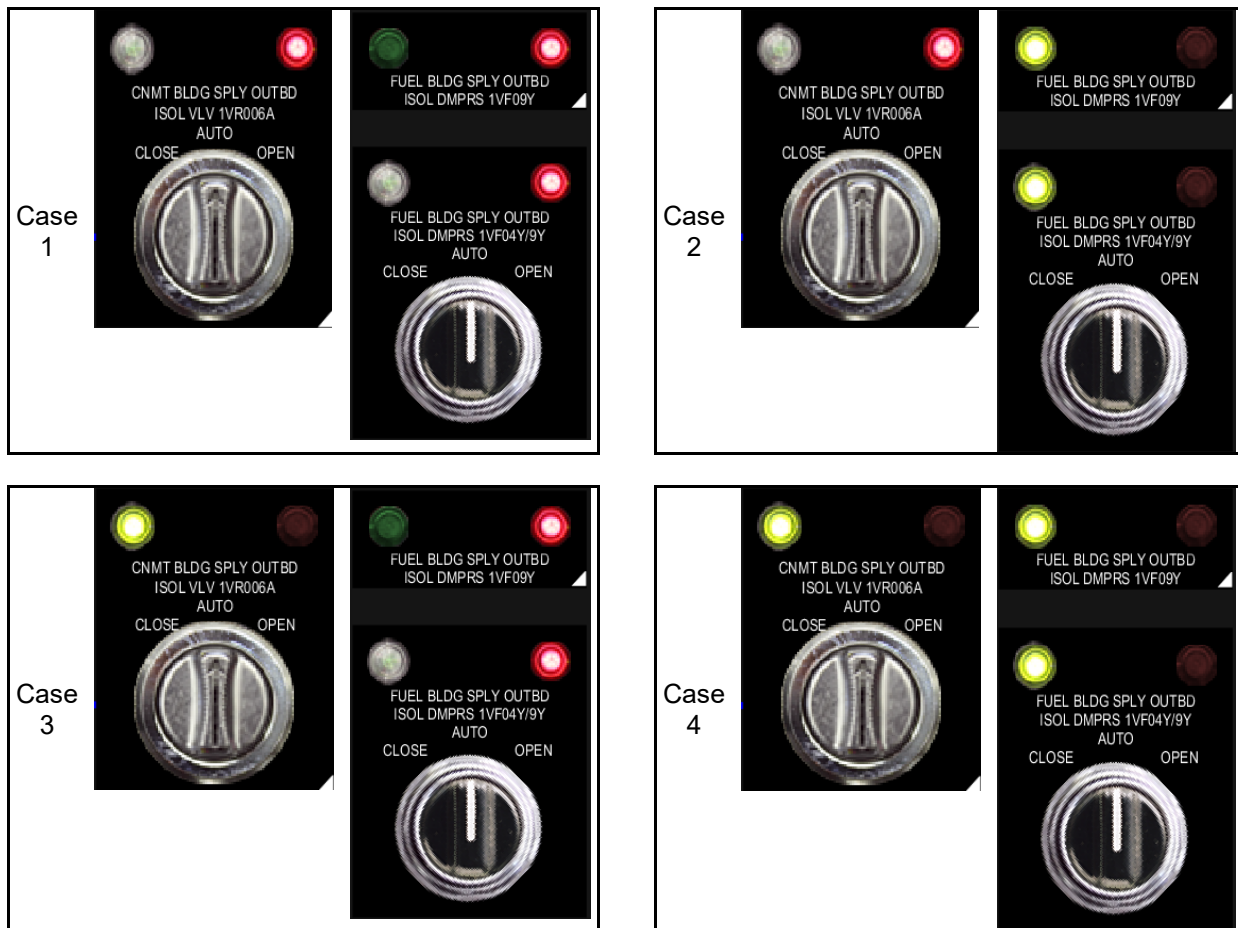

>>

- A. <QQ 2106964(1480)><<Case 1>>
- B. <QQ 2106964(1480)><<Case 2>>
- C. <QQ 2106964(1480)><<Case 3>>
- D. <QQ 2106964(1480)><<Case 4>>

Answer	<QQ 2106964(1419)><>
--------	-------------------------

Answer Explanation

<QQ 2106964(1412)><<B is correct.

Per CPS 5140.63 AR/PR Annunciator - Fuel Building Exhaust 1RIX-PR006A, B, C, D Auto Actions:

A trip of 1RIX-PR006A or B coincident with a trip of 1RIX-PR006C or D will cause automatic isolation of Group 19 (VF) and automatic start of VG A and B.

Per CPS 4001.02C001 Automatic Isolation Checklist, Group 19 Secondary Containment Isolation contains:

- 1VF09Y Fuel Building Exhaust Outboard Isolation Damper
- 1VF04Y Fuel Building Supply Outboard Isolation Damper
- 1VF07Y Fuel Building Exhaust Inboard Isolation Damper
- 1VF06Y Fuel Building Supply Inboard Isolation Damper

Per CPS 4001.02C001 Automatic Isolation Checklist, Group 10 Containment (partial list) contains:

- 1VR006A Containment Building Outboard Isolation Valve
- 1VR006B Containment Building Inboard Isolation Valve

Although 1VR006A/B will shut on an appropriate automatic isolation signal, Group 10 does not actuate on an automatic isolation signal from Fuel Building Exhaust 1RIX-PR006A, B, C, D.

Incorrect Responses:

A is incorrect but plausible because it is partially correct. While 1VR006A will stay open, the Fuel Building Supply Outboard Isolation Dampers will isolate on a Group 19 automatic isolation signal from Fuel Building Exhaust 1RIX-PR006A, B, C, D.

C is incorrect but plausible. A plausible misconception is that Group 10 actuates on an automatic isolation signal from Fuel Building Exhaust 1RIX-PR006A, B, C, D and will cause 1VR006A to shut. Also, the Fuel Building Supply Outboard Isolation Dampers will isolate on a Group 19 automatic isolation signal from Fuel Building Exhaust 1RIX-PR006A, B, C, D.

D is incorrect but plausible because it is partially correct. While the Fuel Building Supply Outboard Isolation Dampers will isolate on a Group 19 automatic isolation signal from Fuel Building Exhaust 1RIX-PR006A, B, C, D; a plausible misconception is that Group 10 actuates on an automatic isolation signal from Fuel Building Exhaust 1RIX-PR006A, B, C, D and will cause 1VR006A to shut.>>

Question Information

Topic	<QQ 2106964(1400)><<The plant was operating at rated thermal power. THEN, the following alarms were received: 1RI>>				
User ID	<QQ 2106964(1404)><<CL-ILT-N19064>>			System ID	<QQ 2106964(1445)><<2106964>>
Status	<QQ 2106964(1405)><<Active>>	Point Value	<QQ 2106964(1441)><<1.00>>	Time (min)	<QQ 2106964(1408)><<0>>

Open or Closed Reference	<QQ 2106964(1409)><<CLOSED>>
Operator Type_Cognitive Level	<QQ 2106964(1415)><<RO-HIGH>>
Operator Discipline	<QQ 2106964(1413)><<LO-I>>

References Provided	None
K/A Justification	This question meets the KA because the candidate must recognize an isolation signal and select the stem graphic which match the expected automatic operations to answer the question.
SRO-Only Justification	N/A
Additional Information	This is a high cog question written at the analysis and application level. The candidate must analyze the parameters in stem and then determine the expected automatic operations based on the analysis (3-PEO).

NRC Exams Only			
Question Type	New	Difficulty	N/A
Technical Reference and Revision #	<ul style="list-style-type: none"> CPS 5140.63 Rev. 1c CPS 4001.02C001 Rev. 16c 		
Training Objective	223002.16 EVALUATE the following CRVICS indications/responses and DETERMINE if the indication/ response is expected and normal. .1 Isolation signal		
Previous NRC Exam Use	None		

K/A Reference(s)

<CM 239799(1002)><<288000.A3.01>>	Safety Function 9	Tier 2	Group 2	RO Imp: 3.8	SRO Imp: 3.8
<CM 239798(1001)><<Ability to monitor automatic operations of the PLANT VENTILATION SYSTEMS including: (CFR: 41.7 / 45.7)>> <CM 239799(1001)><<Isolation/initiation signals>>					

Learning Objective(s)

 <OB 1537883(1101)><<Q64 288000 A3.01 (NH)>>
 User (Sys) ID N/A (<OB 1537883(1125)><<1537883>>)

Cross Reference Links

None

Question 65	ID: 2151382	Points: 1.00
-------------	-------------	--------------

<QQ 2151382(1410)><<The plant is operating at RTP.

THEN, a transient occurs that results in the following:

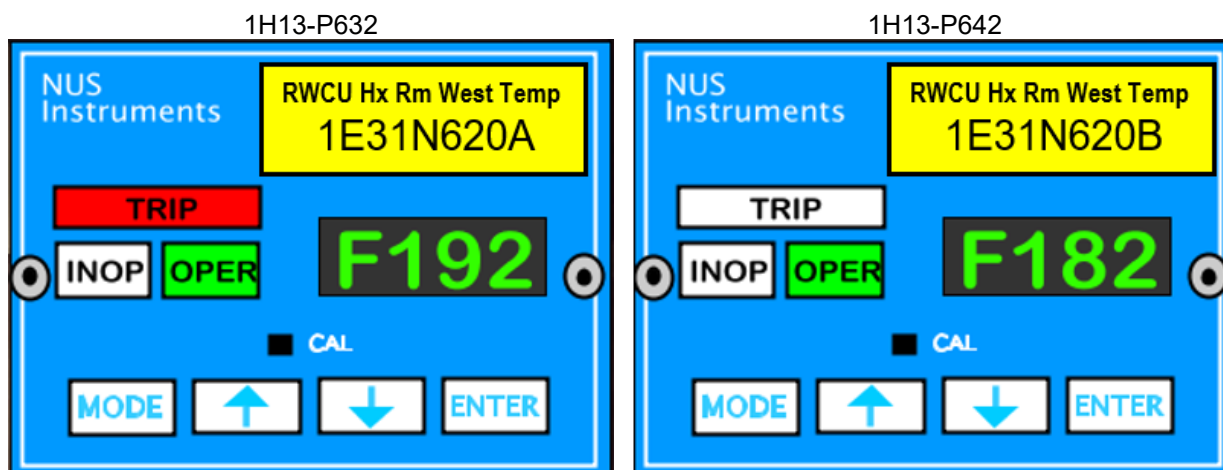

Which of the following conditions are consistent with these indications?>>

- A. <QQ 2151382(1480)><<ONLY the INBOARD RWCU containment isolation valves should have isolated.>>
- B. <QQ 2151382(1480)><<ONLY the OUTBOARD RWCU containment isolation valves should have isolated.>>
- C. <QQ 2151382(1480)><<BOTH the INBOARD and OUTBOARD RWCU containment isolation valves should have isolated.>>
- D. <QQ 2151382(1480)><<NEITHER the INBOARD or OUTBOARD RWCU containment isolation valves should have isolated.>>

Answer	<QQ 2151382(1419)><>
--------	-------------------------

Answer Explanation

<QQ 2151382(1412)><<B is correct:

Per CPS 5000.05 Alarm Panel 5000 Annunciators - Row 5 (5A) RWCU HX RM WEST TEMP HI alarm provides indication of a high energy leak into the 'A' RWCU Heat Exchanger room which exceeds the CRVICS Group 4 isolation setpoint.

Since ONLY trip module E31-N620A is reading above the trip setpoint (190°F), ONLY Div 1 (outboard) CRVICS Group 4 (RWCU) Isolation Valves should have isolated.

Incorrect Responses:

A is incorrect but plausible. This answer would be correct if the trip module E31-N620A affect the Div 2 RWCU containment isolation valves or Div 1 RWCU containment isolation valves were outboard isolation valves.

B is incorrect but plausible. This answer would be correct if the CRVICS Group 4 (RWCU) Isolation Valves (inboard & outboard) isolated based on 1 out of 2 logic. Therefore, with trip module E31-N620A reading above the trip setpoint, the CRVICS Group 4 (RWCU) Isolation Valves (inboard & outboard) would isolate.

D is incorrect but plausible. This answer would be correct if the CRVICS Group 4 (RWCU) Isolation Valves (inboard & outboard) isolated based on 2 out of 2 logic. Therefore, with ONLY trip module E31-N620A reading above the trip setpoint, the CRVICS Group 4 (RWCU) Isolation Valves (inboard & outboard) would NOT isolate.>>

Question Information

Topic	<QQ 2151382(1400)><<The plant is operating at RTP. THEN, a transient occurs that results in the following: 1H13-P>>				
User ID	<QQ 2151382(1404)><<CL-ILT-N19065>>			System ID	<QQ 2151382(1445)><<2151382>>
Status	<QQ 2151382(1405)><<Active>>	Point Value	<QQ 2151382(1441)><<1.00>>	Time (min)	<QQ 2151382(1408)><<0>>

Open or Closed Reference	<QQ 2151382(1409)><<CLOSED>>
Operator Type_Cognitive Level	<QQ 2151382(1415)><<RO-MEMORY>>
Operator Discipline	<QQ 2151382(1413)><<LO-I>>
10CFR55 Content	<TB 479392(1305)><<CFR: 41.7 Design, components, and functions of control and safety systems, including instrumentation, signals, interlocks, failure modes, and automatic and manual features.>>

References Provided	None
K/A Justification	Question meets the KA because the candidate must determine how the RWCU system should respond based on the meter indications provided in the stem.
SRO-Only Justification	N/A
Additional Information	Question is low cog written at the memory level. The candidate must interpret the graphics given in

	the stem and recall the RWCU system interlocks that are actuated on a high ambient temperature condition in the RWCU Heat Exchanger Rooms (1-F).
--	--

NRC Exams Only			
Question Type	New	Difficulty	N/A
Technical Reference and Revision #	<ul style="list-style-type: none"> CPS 4001.02C001 Rev. 16c CPS 5000.05 (5A) Rev. 27 		
Training Objective	204000.16 EVALUATE the following RWCU indications/responses and DETERMINE if the indication/ response is expected and normal. .3 Response to interlocks and trips designed to protect system components		
Previous NRC Exam Use	None		

K/A Reference(s)

<CM 239849(1002)><<290001.A4.02>>	Safety Function 5	Tier 2	Group 2	RO Imp: 3.3	SRO Imp: 3.4
<CM 239847(1001)><<Ability to manually operate and/or monitor in the control room: (CFR: 41.7 / 45.5 to 45.8)>> <CM 239849(1001)><<Reactor building area temperatures: Plant-Specific>>					

Learning Objective(s)

 <OB 1537884(1101)><<Q65 290001 A4.02 (NL)>>
 User (Sys) ID N/A (<OB 1537884(1125)><<1537884>>)

Cross Reference Links

None

Question 66	ID: 2161621	Points: 1.00
-------------	-------------	--------------

<QQ 2161621(1410)><<The 'B' Reactor Operator (RO) is preparing to brief an Equipment Operator (EO) on the performance of a scheduled work activity in the field. The activity is frequently performed and High Risk, with critical steps. This is NOT a first-time activity for this EO.

What MINIMUM level of brief should the RO conduct?>>

- A. <QQ 2161621(1480)><<Task Preview>>
- B. <QQ 2161621(1480)><<Tailored Pre-Job Brief>>
- C. <QQ 2161621(1480)><<Standard Pre-Job Brief>>
- D. <QQ 2161621(1480)><<Heightened Level of Awareness (HLA) Brief>>

Answer	<QQ 2161621(1419)><>
--------	-------------------------

Answer Explanation

<QQ 2161621(1412)><<B is correct.

Per HU-AA-1211, Pre Job Briefings, section 4.1.4, a Tailored Pre-Job Briefing should be used for simple or frequently performed activities that are High Risk, such as those involving critical steps.

Incorrect Responses:

A is incorrect but plausible, because Task Previews are conducted for many frequently performed activities, such as operator rounds and administrative tasks. However, the High Risk nature of the task requires a Tailored Pre-Job Brief.

C is incorrect but plausible, because Standard Pre-Job Briefs are the type most often held for field activities, and are utilized for several complex activities. However, a Tailored Pre-Job Briefing is required due to the High Risk nature of the job.

D is incorrect but plausible, because HLA briefs are required for many High Risk activities. However, since this activity is frequently performed, an HLA brief is not necessary. The Tailored Pre-Job Brief should be performed per HU-AA-1211, section 4.1.4 and the table in section 2.9.>>

Question Information

Topic	<QQ 2161621(1400)><<The 'B' Reactor Operator (RO) is preparing to brief an Equipment Operator (EO) on the performance o>>				
User ID	<QQ 2161621(1404)><<CL-ILT-N19066>>			System ID	<QQ 2161621(1445)><<2161621>>
Status	<QQ 2161621(1405)><<Active>>	Point Value	<QQ 2161621(1441)><<1.00>>	Time (min)	<QQ 2161621(1408)><<0>>

Open or Closed Reference	<QQ 2161621(1409)><<CLOSED>>
Operator Type_Cognitive Level	<QQ 2161621(1415)><<RO-MEMORY>>
Operator Discipline	<QQ 2161621(1413)><<LO-I>>
10CFR55 Content	<TB 479395(1305)><<CFR: 41.10 Administrative, normal, abnormal, and emergency operating procedures for the facility.>>

References Provided	None
K/A Justification	Coordinating activities outside the MCR is a complex task that includes specific procedurally directed briefing requirements. Question meets the KA because the candidate must demonstrate knowledge of briefing requirements for activities outside the MCR that the RO may coordinate.
SRO-Only Justification	N/A
Additional Information	Question is low cog written at the memory level. The candidate must recall procedure requirements to answer the question (1-P).

NRC Exams Only			
Question Type	New	Difficulty	N/A
Technical Reference and Revision #	• HU-AA-1211, Rev 14		
Training Objective	LP85801.2.1.8Ability to coordinate personnel activities outside the control room.		
Previous NRC Exam Use	None		

K/A Reference(s)

<CM 241894(1002)><<B2.1.08>>	Safety Function 5	Tier 3	Group	RO Imp: 3.4	SRO Imp: 4.1
<CM 241894(1001)><<Ability to coordinate personnel activities outside the control room. (CFR: 41.10 / 45.5 / 45.12 / 45.13)>>					

Learning Objective(s)

 <OB 1537885(1101)><<Q66 2.1.8 (NL)>>

User (Sys) ID N/A (<OB 1537885(1125)><<1537885>>)

Cross Reference Links

Table: <TB 775424(1301)><<TRAINING - QUESTIONS - Track Questions Modified in this Project (CL-OPS-EXAM-ILT)>>

<TB 776405(1305)><<Tracking link in project CL-OPS-EXAM-ILT to source question 2151343>>
--

Question 67

ID: 2151340

Points: 1.00

<QQ 2151340(1410)><<To maintain a valid NRC license, the MAXIMUM amount of time that may elapse between required medical exams is ____ (1) ____ .

Having laser eye surgery ____ (2) ____ constitute a change in medical status that must be reported.>>

- A. <QQ 2151340(1480)><<(1) every six years (2) does>>
- B. <QQ 2151340(1480)><<(1) every six years (2) does NOT>>
- C. <QQ 2151340(1480)><<(1) every two years (biennially) (2) does>>
- D. <QQ 2151340(1480)><<(1) every two years (biennially) (2) does NOT>>

Answer

<QQ 2151340(1419)><<C>>

Answer Explanation

<QQ 2151340(1412)><<C is correct. Per OP-AA-105-101 Administrative Process for NRC License and Medical Requirements:

- Reporting changes to license status is the responsibility of the individual licensee, including notification to the Licensee's supervisor, and Occupational Health Services (OHS) prior to the next scheduled shift. Required reports to the NRC as a result will be made with assistance of the Operations Support Manager, OHS, Training, and Regulatory Assurance organizations.
- A biennial medical examination is required by the NRC for all licensed individuals. This medical examination is required for ALL NRC licensed individuals (active and inactive license status).

OP-AA-105-101 step 4.5.1, also requires reporting of changes in health status such as:

- High blood pressure and / or medication changes
- Angina or coronary disease (chest pain, heart disease)
- Heart rhythm abnormality
- Stroke or TIA (cerebral vascular accident or transient ischemic attacks)
- Fainting spells, seizures, or epilepsy
- Asthma
- Arthritis (limiting mobility)
- Fracture or joint dislocation
- Diabetes and / or medication changes
- Cirrhosis, hepatitis, or other liver disorders
- Diagnosed psychiatric or psychological condition and medications used in treatment
- Alcoholism, alcohol abuse, alcohol dependency
- Drug dependency
- Changes in vision, including glaucoma, cataracts, or laser eye surgery

- Changes in hearing
- All types of cancer (even successful surgery)
- Skin condition (limiting ability to work or wear respirator)
- Bleeding from stomach or bowel
- Emphysema or chronic bronchitis
- Surgery or traumatic injury
- Sleep apnea
- Medications and medication changes

Incorrect Responses:

A is incorrect but plausible. The first part is plausible because license renewal is required every 6 years; however, per OP-AA-105-101 a medical examination is given every 2 years, required by the NRC for all licensed individuals. For purposes of the medical examination, “biennial” is a period of time equal to 730 days and synonymous with the term “two years”. The second part is correct.

B is incorrect but plausible. The first part is plausible because license renewal is required every 6 years; however, per OP-AA-105-101 a medical examination is given every 2 years, required by the NRC for all licensed individuals. For purposes of the medical examination, “biennial” is a period of time equal to 730 days and synonymous with the term “two years”. The second part is plausible because laser eye surgery, despite wide availability, minimal invasiveness, and short recovery time, still constitutes a change in medical status. Per OP-AA-105-101 the NRC notification is only required in the case of a permanent condition, but determination needs to be made for every health status change.

D is incorrect but plausible. The first part is correct. However, laser eye surgery, despite wide availability, minimal invasiveness, and short recovery time, still constitutes a change in medical status. Per OP-AA-105-101 the NRC notification is only required in the case of a permanent condition, but determination needs to be made for every health status change.>>

Question Information

Topic	<QQ 2151340(1400)><<To maintain a valid NRC license, the MAXIMUM amount of time that may elapse between required medica>>				
User ID	<QQ 2151340(1404)><<CL-ILT-N19067>>			System ID	<QQ 2151340(1445)><<2151340>>
Status	<QQ 2151340(1405)><<Active>>	Point Value	<QQ 2151340(1441)><<1.00>>	Time (min)	<QQ 2151340(1408)><<0>>

Open or Closed Reference	<QQ 2151340(1409)><<CLOSED>>
Operator Type_Cognitive Level	<QQ 2151340(1415)><<RO-MEMORY>>
Operator Discipline	<QQ 2151340(1413)><<LO-I>>
10CFR55 Content	<TB 479395(1305)><<CFR: 41.10 Administrative, normal, abnormal, and emergency operating procedures for the facility.>>

References Provided	None
K/A Justification	Question meets the KA because the candidate

	must demonstrate knowledge of the licensed operator responsibilities regarding medical requirements for maintaining a valid NRC RO license.
SRO-Only Justification	N/A
Additional Information	Question is low cog written at the memory level. The candidate must recall procedure requirements to answer the question (1-P).

NRC Exams Only			
Question Type	Bank (CL-ILT-A12066)	Difficulty	N/A
Technical Reference and Revision #	<ul style="list-style-type: none"> OP-AA-105-101 Rev. 24 		
Training Objective	LP85801.2.1.4 Knowledge of individual licensed operator responsibilities related to shift staffing, such as medical requirements, "no solo" operation, maintenance of active license status, 10CFR55, etc.		
Previous NRC Exam Use	None		

K/A Reference(s)

<CM 241890(1002)><<B2.1.04>>	Safety Function 5	Tier 3	Group	RO Imp: 3.3	SRO Imp: 3.8
<CM 241890(1001)><<Knowledge of individual licensed operator responsibilities related to shift staffing, such as medical requirements, "no-solo" operation, maintenance of active license status, 10CFR55, etc. (CFR: 41.10 / 43.2)>>					

Learning Objective(s)

 <OB 1537886(1101)><<Q67 2.1.4 (BL)>>
 User (Sys) ID N/A (<OB 1537886(1125)><<1537886>>)

Cross Reference Links

None

Question 68	ID: 2151325	Points: 1.00
-------------	-------------	--------------

<QQ 2151325(1410)><<A Reactor Operator (RO) is preparing for a surveillance. Annunciators are expected to come in during the performance of the surveillance.

Which of the steps below MUST be taken by the RO in advance of an expected annunciator which would allow the RO to announce it as an "Expected Alarm"?

1. Enter the expected annunciator in the Narrative Logs.
 2. Discuss the expected annunciator with the Control Room Supervisor.
 3. Flag the expected annunciator.>>
- A. <QQ 2151325(1480)><<1 ONLY>>
- B. <QQ 2151325(1480)><<1 and 3 ONLY>>
- C. <QQ 2151325(1480)><<2 ONLY>>
- D. <QQ 2151325(1480)><<2 and 3 ONLY>>

Answer	<QQ 2151325(1419)><<C>>
--------	-------------------------

Answer Explanation

<QQ 2151325(1412)><<C is correct.

Per OP-AA-103-102 Watchstanding Practices

4.5.5.3. The Reactor Operator (RO) shall INFORM the Unit Supervisor (Control Room Supervisor/CRS) of the planned alarms prior to their actuation.

- B. Flagging of expected alarms using colored dots or stickers is recommended to denote the fact that they have been discussed ahead of time, especially for alarms that are expected to be repetitive. (re:HU-AA-101, "Human Performance Tools and Verification Practices")
- C. Expected alarms need not be announced in detail provided they have been discussed with the Unit Supervisor. "Expected Alarm" is an acceptable announcement for these occurrences.
- D. Expected alarms need not be announced provided they have been flagged and discussed with the Unit Supervisor.
- E. Expected alarms that have not been flagged should be announced to the Unit Supervisor. "Expected Alarm" is an acceptable announcement for these occurrences.

4.5.6. If an alarm is directly related to a planned activity but all expected alarm requirements were not met, then the standard for unexpected alarms shall be followed.

Incorrect Responses:

A is incorrect but plausible. This response is plausible because most other (not expected) annunciators/alarms are required to be logged in the Narrative Logs in accordance with OP-CL-108-101-1003 Operations Department Standards And Expectations. However, there is no requirement to log expected annunciators/alarms in the Narrative Logs.

B is incorrect but plausible. The first part of this response is plausible because most other (not expected) annunciators/alarms are required to be logged in the Narrative Logs in accordance with OP-CL-108-101-1003 Operations Department Standards And Expectations. However, there is no requirement to log expected annunciators/alarms in the Narrative Logs.

The second part of this response is plausible because flagging expected annunciators is normally done for expected alarms; however, it is not required per OP-AA-103-102.

D is incorrect but plausible. The first part of this response is correct. The second part of this response is plausible because flagging expected annunciators is normally done for expected alarms; however, it is not required per OP-AA-103-102.>>

Question Information

Topic	<QQ 2151325(1400)><<A Reactor Operator (RO) is preparing for a surveillance. Annunciators are expected to come in duri>>				
User ID	<QQ 2151325(1404)><<CL-ILT-N19068>>		System ID	<QQ 2151325(1445)>><<2151325>>	
Status	<QQ 2151325(1405)>><<Active>>	Point Value	<QQ 2151325(1441)>><<1.00>>	Time (min)	<QQ 2151325(1408)>><<0>>

Open or Closed Reference	<QQ 2151325(1409)><<CLOSED>>
Operator Type_Cognitive Level	<QQ 2151325(1415)><<RO-MEMORY>>
Operator Discipline	<QQ 2151325(1413)><<LO-I>>
10CFR55 Content	<TB 479395(1305)><<CFR: 41.10 Administrative, normal, abnormal, and emergency operating procedures for the facility.>>

References Provided	None
K/A Justification	Question meets the KA because the candidate must demonstrate the ability to make accurate verbal reports based on the circumstances presented in the stem.
SRO-Only Justification	N/A
Additional Information	Question is low cog written at the memory level. The candidate must recall facts pertaining to making verbal reports (1-F).

NRC Exams Only			
Question Type	New	Difficulty	N/A

Technical Reference and Revision #	<ul style="list-style-type: none"> OP-AA-103-102 Rev. 19 OP-CL-108-101-1003 Rev. 38
Training Objective	LP85801.2.1.17 Ability to make accurate / clear and concise verbal reports.
Previous NRC Exam Use	None

K/A Reference(s)

<CM 241903(1002)><<B2.1.17>>	Safety Function 5	Tier 3	Group	RO Imp: 3.9	SRO Imp: 4.0
<CM 241903(1001)><<Ability to make accurate, clear, and concise verbal reports. (CFR: 41.10 / 45.12 / 45.13)>>					

Learning Objective(s)

 <OB 1537887(1101)><<Q68 2.1.17 (NL)>>
 User (Sys) ID N/A (<OB 1537887(1125)><<1537887>>)

Cross Reference Links

None

Question 69	ID: 2151291	Points: 1.00
-------------	-------------	--------------

<QQ 2151291(1410)><<The Control Room Supervisor has directed you to perform stroke time testing of a valve required by Technical Specifications for post-maintenance testing to restore operability.

To time this valve OPEN, the RO will START the stopwatch when the ____ (1) ____, and will STOP the stopwatch ____ (2) ____.>>

- A. <QQ 2151291(1480)><<(1) control switch is placed to OPEN
(2) 5 seconds AFTER the green light extinguishes>>
- B. <QQ 2151291(1480)><<(1) control switch is placed to OPEN
(2) when the green position indication light extinguishes>>
- C. <QQ 2151291(1480)><<(1) red position indication light FIRST illuminates
(2) when the green position indication light extinguishes>>
- D. <QQ 2151291(1480)><<(1) red position indication light FIRST illuminates
(2) 5 seconds AFTER the green light extinguishes>>

Answer	<QQ 2151291(1419)><>
--------	-------------------------

Answer Explanation

<QQ 2151291(1412)><<B is correct.

Per CPS 9061.03 Containment / Drywell Isolation Valve Three-Month Operability step 2.2.1, stroke time is defined from control switch actuation to receipt of the desired position.

For motor operated valves at CPS, the red position indication light indicates that the valve is open, the green light indicates the valve is closed, and dual position (both red and green lights on) indicates that valve is in the intermediate position (not full open or closed).

Incorrect Responses:

A is incorrect but plausible. The first part of this response is correct. The second part of this response would be correct if a five (5) second delay was required to ensure that the visual indication of position and the actual position were the same. This is similar to the requirement to hold the control switch for MOV throttle valves for ~ 5 seconds after seeing the closed indication to ensure the valve is fully closed (OP-CL-108-101-1001 General Equipment Operating Requirements step 3.3.1). However, the requirements of OP-CL-108-101-1001 do not apply in this case.

C is incorrect but plausible. The first part of this response would be correct if starting the stopwatch was performed concurrent with the indication change instead of the control switch actuation. This is similar to the requirement to start a 5 second countdown after seeing the closed indication (OP-CL-108-101-1001 General Equipment Operating Requirements step 3.3.1). However, the stopwatch is started concurrent with the control switch manipulation. The second part of the response is correct.

D is incorrect but plausible. The response would be correct if:

- starting the stopwatch was performed concurrent with the indication change instead of the control switch actuation. This is similar to the requirement to start a 5 second countdown after seeing the closed indication (OP-CL-108-101-1001), AND
- a five (5) second delay was required to ensure that the visual indication of position and the actual position were the same. This is similar to the requirement to hold the control switch for MOV throttle valves for ~ 5 seconds after seeing the closed indication to ensure the valve is fully closed (OP-CL-108-101-1001).>>

Question Information

Topic	<QQ 2151291(1400)><<The Control Room Supervisor has directed you to perform stroke time testing of a valve required by >>				
User ID	<QQ 2151291(1404)><<CL-ILT-N19069>>			System ID	<QQ 2151291(1445)><<2151291>>
Status	<QQ 2151291(1405)><<Active>>	Point Value	<QQ 2151291(1441)><<1.00>>	Time (min)	<QQ 2151291(1408)><<0>>

Open or Closed Reference	<QQ 2151291(1409)><<CLOSED>>
Operator Type_Cognitive Level	<QQ 2151291(1415)><<RO-MEMORY>>
Operator Discipline	<QQ 2151291(1413)><<LO-I>>
10CFR55 Content	<TB 479395(1305)><<CFR: 41.10 Administrative, normal, abnormal, and emergency operating procedures for the facility.>>

References Provided	None
K/A Justification	Question meets the KA because the candidate must identify the requirements to perform valve stroke timing following maintenance to ensure operability of the system in question.
SRO-Only Justification	N/A
Additional Information	Question is low cog written at the memory level. The candidate must recall steps contained in two operating procedures (1-P).

NRC Exams Only			
Question Type	Bank (CL-ILT-N14069)	Difficulty	N/A
Technical Reference and Revision #	<ul style="list-style-type: none"> • OP-CL-108-101-1001 Rev. 12b • CPS 9061.03 Rev. 40 		
Training Objective	LP85802.2.2.21 Knowledge of pre and post maintenance operability requirements.		

Previous NRC Exam Use	ILT 14-1 NRC
-----------------------	--------------

K/A Reference(s)

<CM 241942(1002)><<B2.2.21>>	Safety Function 5	Tier 3	Group	RO Imp: 2.9	SRO Imp: 4.1
<CM 241942(1001)><<Knowledge of pre- and post-maintenance operability requirements. (CFR: 41.10 / 43.2)>>					

Learning Objective(s)

 <OB 1537888(1101)><<Q69 2.2.21 (BL)>>
 User (Sys) ID N/A (<OB 1537888(1125)><<1537888>>)

Cross Reference Links

None

Question 70	ID: 2151282	Points: 1.00
-------------	-------------	--------------

<QQ 2151282(1410)><<Which of the following activities require a Tagout per OP-AA-109-101, Personnel And Equipment Tagout Process?

(Assume as appropriate that the responsible work group agrees that the work can be performed safely).>>

- A. <QQ 2151282(1480)><<Electrical Maintenance work that requires lifting electrical leads.>>
- B. <QQ 2151282(1480)><<Mechanical Maintenance work requiring internal inspection of a check valve.>>
- C. <QQ 2151282(1480)><<Instrument Maintenance work that requires isolation of a pressure instrument.>>
- D. <QQ 2151282(1480)><<Chemistry work requiring filter changeout of Offgas Process Radiation Monitors (PRMs).>>

Answer	<QQ 2151282(1419)><>
--------	-------------------------

Answer Explanation

<QQ 2151282(1412)><<B is correct.

Per OP-AA-109-101 Personnel And Equipment Tagout Process, ATTACHMENT 1: Activities That Do Not Require a Tagout:

This attachment provides guidance to allow specific activities to be performed without a tagout provided the work supervisor, the worker associated with the activity, and Operations agree that adequate safety will be maintained.

- Only one individual will perform hands-on work (or a two-person team functioning in a worker-peer checker format).
-
- The individual worker clearly understands that he/she has sole responsibility for his/her personal safety during the work activity.
- The individual performing hands-on work has direct line of sight and sole control of the isolation boundaries and is close enough to intervene should someone attempt to manipulate an isolation boundary.
- The safety hazard is not complex (for example, multiple types of hazards present).
- Installed personnel safety guards and personnel safety interlocks remain intact and/or are properly used (ANSI B11.19-1990 describes typical safeguards and alternatives).
- The activity involves routine/periodic or minor servicing of operational equipment.
- The work group must demonstrate that the alternative measures contained in the work document provide effective protection from the hazardous energy.

EXAMPLES:

- Instrument Maintenance work that requires isolation of instruments
- Lifting of electrical leads, when the work group agrees that work can be performed safely while energized
- Filter changes
- Charging Accumulators
- Nitrogen or other gas bottle change-outs
- Service Air and Instrument Air hose connections, pipe cap and fitting connections
-
- Flange and pipe cap removal and installation for general plant support activities
-
- Hose connections for general plant activities (breathing air, fire protection, demineralized water, etc.)

The mechanical maintenance work requiring the internal inspection of a check valve is not covered by the exceptions of ATTACHMENT 1 and would require a clearance IAW OP-AA-109-101 prior to performance.

Incorrect Responses:

All incorrect responses are examples of activities that do not require a tagout IAW ATTACHMENT 1.

A is incorrect but plausible. This response is plausible because the electrical leads are energized and the presence of electricity is a hazard to be considered when determining clearance requirements.

C is incorrect but plausible. This response is plausible because the pressure instrument and associated lines are pressurized and the presence of pressurized fluid is a hazard to be considered when determining clearance requirements.

D is incorrect but plausible. This response is plausible because the Process Radiation Monitor must be secured and isolated prior to the filter replacement. Both must be considered when determining clearance requirements.>>

Question Information

Topic	<QQ 2151282(1400)><<Which of the following activities require a Tagout per OP-AA-109-101, Personnel And Equipment Tagou>>				
User ID	<QQ 2151282(1404)><<CL-ILT-N19070>>			System ID	<QQ 2151282(1445)><<2151282>>
Status	<QQ 2151282(1405)><<Active>>	Point Value	<QQ 2151282(1441)><<1.00>>	Time (min)	<QQ 2151282(1408)><<0>>

Open or Closed Reference	<QQ 2151282(1409)><<CLOSED>>
Operator Type_Cognitive Level	<QQ 2151282(1415)><<RO-MEMORY>>
Operator Discipline	<QQ 2151282(1413)><<LO-I>>
10CFR55 Content	<TB 479395(1305)><<CFR: 41.10 Administrative, normal, abnormal, and emergency operating procedures for the facility.>>

References Provided	None
K/A Justification	This question meets the KA because the candidate must recall knowledge of tagging and clearance procedures.
SRO-Only Justification	N/A
Additional Information	Question is low cog written at the memory level. The candidate must recall Operating procedure steps (1-P).

NRC Exams Only			
Question Type	New	Difficulty	N/A
Technical Reference and Revision #	• OP-AA-109-101 Rev. 15		
Training Objective	LP85802.2.2.13 Knowledge of tagging and clearance procedures.		
Previous NRC Exam Use	None		

K/A Reference(s)

<CM 241934(1002)><<B2.2.13>>	Safety Function 5	Tier 3	Group	RO Imp: 4.1	SRO Imp: 4.3
<CM 241934(1001)><<Knowledge of tagging and clearance procedures. (CFR: 41.10 / 45.13)>>					

Learning Objective(s)

 <OB 1537889(1101)><<Q70 2.2.13 (NL)>>

User (Sys) ID N/A (<OB 1537889(1125)><<1537889>>)

Cross Reference Links

None

Question 71	ID: 2151264	Points: 1.00
-------------	-------------	--------------

<QQ 2151264(1410)><<You are conducting a pre-shift turnover and note annunciator 5060-8E, DIESEL GENERATOR 1A TROUBLE, has a blue flag on it.

Which of the following describes the status of Annunciator 5060-8E?>>

- A. <QQ 2151264(1480)><<Partially Disabled annunciator.>>
- B. <QQ 2151264(1480)><<Out of Service annunciator.>>
- C. <QQ 2151264(1480)><<Fully Disabled annunciator.>>
- D. <QQ 2151264(1480)><<Nuisance Annunciator removed from service.>>

Answer	<QQ 2151264(1419)><>
--------	-------------------------

Answer Explanation

<QQ 2151264(1412)><<B is correct.

Per CPS 1406.01 ANNUNCIATOR TRACKING PROGRAM, a BLUE flag is used to identify an Out of Service annunciator. An Out Of Service annunciator is defined as "an annunciator that is not functioning properly due to alarms without a valid condition, fails to alarm with a valid condition present, or alarm condition due to an out of cal instrument" per CPS 1406.01.

Incorrect Responses:

A is incorrect but plausible because a colored flag is used to identify an Out of Service annunciator. However, per CPS 1406.01 an ORANGE flag is used to identify a Partially Disabled annunciator.

C is incorrect but plausible because a colored flag is used to identify an Out of Service annunciator. However, per CPS 1406.01 a RED flag is used to identify a Fully Disabled annunciator. A Fully Disabled annunciator is defined as "an annunciator that has been fully disabled from the input circuit (DAF). All annunciator inputs have been disabled by pulling the annunciator card or other approved mechanism" per CPS 1406.01.

D in incorrect but plausible because if a Nuisance Alarm is disabled for more than one shift, should be tracked via an Equipment Status Tracking (EST) Tag per OP-AA-103-102 Watchstanding.>>

Question Information

Topic	<QQ 2151264(1400)><<You are conducting a pre-shift turnover and note annunciator 5060-8E, DIESEL GENERATOR 1A TROUBLE, >>				
User ID	<QQ 2151264(1404)><<CL-ILT-N19071>>			System ID	<QQ 2151264(1445)><<2151264>>
Status	<QQ 2151264(1405)><<Active>>	Point Value	<QQ 2151264(1441)><<1.00>>	Time (min)	<QQ 2151264(1408)><<0>>

Open or Closed Reference	<QQ 2151264(1409)><<CLOSED>>
Operator Type_Cognitive Level	<QQ 2151264(1415)><<RO-MEMORY>>
Operator Discipline	<QQ 2151264(1413)><<LO-I>>
10CFR55 Content	<TB 479395(1305)><<CFR: 41.10 Administrative, normal, abnormal, and emergency operating procedures for the facility.>>

References Provided	None
K/A Justification	Question meets the KA because the candidate must have knowledge of the process used to track inoperable annunciators in order to select the correct response.
SRO-Only Justification	N/A
Additional Information	Question is low cog written at the memory level. The candidate must recall procedure definitions and the associated flag colors in order to determine the status of a flagged annunciator (1-P).

NRC Exams Only			
Question Type	Bank (CL-ILT-N11069)	Difficulty	N/A
Technical Reference and Revision #	<ul style="list-style-type: none"> CPS 1406.01 Rev. 14e OP-AA-103-102 Rev. 16 		
Training Objective	LP85802.2.2.43 Knowledge of the process used to track inoperable alarms.		
Previous NRC Exam Use	ILT 10-1 NRC		

K/A Reference(s)

<CM 275327(1002)><<B2.2.43>>	Safety Function 5	Tier 3	Group	RO Imp: 3.0	SRO Imp: 3.3
<CM 275327(1001)><<Knowledge of the process used to track inoperable alarms. (CFR: 41.10 / 43.5 / 45.13)>>					

Learning Objective(s)

 <OB 1537890(1101)><<Q71 2.2.43 (BL)>>

User (Sys) ID N/A (<OB 1537890(1125)><<1537890>>)

Cross Reference Links

None

Question 72	ID: 2151249	Points: 1.00
-------------	-------------	--------------

<QQ 2151249(1410)><<Given the following conditions at a work site:

- Airborne activity: 3 DAC
- Radiation level: 40 mr/hr
- Radiation level with shielding: 10 mr/hr
- Time to place shielding: 15 minutes
- Time to conduct task with respirator: 1 hour
- Time to conduct task without respirator: 30 minutes

Assume the following:

- 2.5mr/DAC-hr.
- The airborne dose with a respirator will be zero (0).
- While installing the shielding, radiation level will be 40 mr/hr.
- The job (shielding installation and task) will be performed by one worker.
- The shielding can be placed in 15 minutes with or without a respirator.
- The shielding will NOT be removed after the job is complete.

Which of the following will result in the lowest whole body dose?>>

- A. <QQ 2151249(1480)><<Conduct the task WITHOUT a respirator or shielding.>>
- B. <QQ 2151249(1480)><<Conduct the task with a respirator and WITHOUT shielding.>>
- C. <QQ 2151249(1480)><<Place the shielding while wearing a respirator and conduct the task with a respirator.>>
- D. <QQ 2151249(1480)><<Place the shielding while wearing a respirator and conduct the task without a respirator.>>

Answer	<QQ 2151249(1419)><<D>>
--------	-------------------------

Answer Explanation

<QQ 2151249(1412)><<D is correct.

Calculations required:

- Dose due to Airborne activity / conducting task without respirator - $3 \text{ DAC} \times 2.5 \text{ mr/DAC-hr} \times 0.5 \text{ hours} = 3.75 \text{ mrem}$
- Dose due to General Area Radiation / conducting the task with a respirator but without shielding - $40 \text{ mr/hr} \times 0.5 \text{ hr} = 20.00 \text{ mrem}$

- Dose due to General Area Radiation / conducting the task without a respirator or shielding - 20 mr + 3.75 mr airborne = 23.75 mrem
- Dose due to General Area Radiation / conducting the task with a respirator and without shielding - 1 hr x 40 mr/hr = 40 mrem
- Dose due to General Area Radiation placing shielding (with or without wearing a respirator) - 40 mr/hr x 0.25 hr = 10 mrem
- Dose due to General Area Radiation with shielding / conducting the task while wearing a respirator - 10 mr placing shielding + 10 mr performing task = 20 mrem
- Dose due to General Area Radiation with shielding installed (ONLY) / conducting the task without wearing a respirator - 10 mr x 0.5 hr = 5 mrem
- Dose to install shielding while wearing a respirator / conducting the task without wearing a respirator - 10 mr to placing shielding + 3.75 mr airborne dose + 5 mr performing task = 18.75 mrem

Incorrect Responses:

A is incorrect but plausible. Without a respirator or shielding - 23.75 mrem. This response would be correct if installing the shielding took the same amount of time as it did to perform the worksite task without a respirator (30 minutes). However, the given time to install shielding is 15 minutes.

B is incorrect but plausible. With a respirator and without shielding - 40.00 mrem. This response would be correct if installing the shielding took the same amount of time as it did to perform the worksite task without a respirator (30 minutes) and required two (2) workers. However, the given time to install shielding is 15 minutes for one (1) worker.

C is incorrect but plausible. With a respirator and shielding - 20.00 mrem. This response would be correct if airborne activity level was > 4 DAC. However, the given airborne activity level is 3 DAC.>>

Question Information

Topic	<QQ 2151249(1400)><<Given the following conditions at a work site: Airborne activity: 3 DAC Radiation level: 40 mr/hr>>				
User ID	<QQ 2151249(1404)><<CL-ILT-N19072>>			System ID	<QQ 2151249(1445)>><<2151249>>
Status	<QQ 2151249(1405)>><<Active>>	Point Value	<QQ 2151249(1441)>><<1.00>>	Time (min)	<QQ 2151249(1408)>><<0>>

Open or Closed Reference	<QQ 2151249(1409)><<CLOSED>>
Operator Type_Cognitive Level	<QQ 2151249(1415)><<RO-HIGH>>
Operator Discipline	<QQ 2151249(1413)><<LO-I>>
10CFR55 Content	<TB 479395(1305)><<CFR: 41.10 Administrative, normal, abnormal, and emergency operating procedures for the facility.>>

References Provided	None
K/A Justification	Question meets the KA because the candidate must demonstrate knowledge of radiation and contamination (airborne activity) hazards during a normal activity.
SRO-Only Justification	N/A
Additional Information	Question is high cog written at the analysis and application level. The candidate must analyze the parameters in the stem, apply knowledge and calculate the potential outcomes to determine the correct response (3-SPK).

NRC Exams Only			
Question Type	Bank (CL-ILT-9127)	Difficulty	N/A
Technical Reference and Revision #	<ul style="list-style-type: none"> RP-AA-441 Rev. 11 		
Training Objective	LP85803.2.3.14 Knowledge of radiation or contamination hazards that may arise during normal, abnormal, or emergency conditions or activities.		
Previous NRC Exam Use	None		

K/A Reference(s)

<CM 275331(1002)><<B2.3.14>>	Safety Function 5	Tier 3	Group	RO Imp: 3.4	SRO Imp: 3.8
<CM 275331(1001)><<Knowledge of radiation or contamination hazards that may arise during normal, abnormal, or emergency conditions or activities. (CFR: 41.12 / 43.4 / 45.10)>>					

Learning Objective(s)

 <OB 1537891(1101)><<Q72 2.3.14 (BH)>>
 User (Sys) ID N/A (<OB 1537891(1125)><<1537891>>)

Cross Reference Links

None

Question 73

ID: 2155023

Points: 1.00

<QQ 2155023(1410)><<An individual has 1800 mR TEDE annual exposure.

This worker is required to perform an evolution with an exposure estimate of 400 mR.

What additional exposure controls are required, if any?>>

- A. <QQ 2155023(1480)><<None. No further exposure is permitted.>>
- B. <QQ 2155023(1480)><<A Planned Special Exposure is required>>
- C. <QQ 2155023(1480)><<An Administrative Dose Extension is required.>>
- D. <QQ 2155023(1480)><<None. Further exposure is permitted but no additional exposure controls are required.>>

Answer

<QQ 2155023(1419)><<C>>

Answer Explanation

<QQ 2155023(1412)><<C is correct.

Per RP-AA-203 Exposure Control and Authorization, you must use Attachment 1, Dose Control Level Extension Form, or a computerized equivalent, to authorize exposures for adult individuals in excess of 2000 mrem routine TEDE in a year.

Incorrect Responses:

A is incorrect but plausible. This response is plausible because the annual routine 10CFR20 administrative dose control level for an adult occupational worker is 2000 mrem. However, the 10CFR20 exposure limit is 5000 mrem (5 rem).

B is incorrect but plausible. This response is plausible because a Planned Special Exposure is required when exceeding the 10CFR20 exposure limit (5 rem). However, that is not required to exceed the annual routine 10CFR20 administrative dose control level for an adult occupational worker of 2000 mrem.

D is incorrect but plausible. This response is plausible because the worker would not exceed the 10CFR20 exposure limit (5 rem). However, an administrative dose control level has been established per RP-AA-203 requiring a Dose Control Extension Form to be completed for adult individuals exceeding 2000 mrem routine TEDE in a year.>>

Question Information

Topic	<QQ 2155023(1400)><<An individual has 1800 mR TEDE annual exposure. This worker is required to perform an evolution >>				
User ID	<QQ 2155023(1404)><<CL-ILT-N19073>>			System ID	<QQ 2155023(1445)><<2155023>>
Status	<QQ 2155023(1405)><<Active>>	Point Value	<QQ 2155023(1441)><<1.00>>	Time (min)	<QQ 2155023(1408)><<0>>

Open or Closed Reference	<QQ 2155023(1409)><<CLOSED>>
Operator Type_Cognitive Level	<QQ 2155023(1415)><<RO-MEMORY>>
Operator Discipline	<QQ 2155023(1413)><<LO-I>>
10CFR55 Content	<TB 479395(1305)><<CFR: 41.10 Administrative, normal, abnormal, and emergency operating procedures for the facility.>>

References Provided	None
K/A Justification	Question meets the KA because to answer the question the candidate must recognize the appropriate dose controls based on radiation exposure limits under normal conditions.
SRO-Only Justification	N/A
Additional Information	Question is low cog written at the memory level. The candidate must recall radiation exposure limits and recognize the proceduralized dose controls required during a normal evolution (1-P).

NRC Exams Only			
Question Type	Bank (CL-ILT-N11070, CL-ILT-N15071)	Difficulty	N/A
Technical Reference and Revision #	<ul style="list-style-type: none"> RP-AA-203 Rev. 5 		
Training Objective	LP85803.2.3.4 Knowledge of radiation exposure limits under normal or emergency conditions.		
Previous NRC Exam Use	ILT 10-1 NRC ILT 15-1 NRC		

K/A Reference(s)

<CM 241960(1002)><<B2.3.04>>	Safety Function 5	Tier 3	Group	RO Imp: 3.2	SRO Imp: 3.7
<CM 241960(1001)><<Knowledge of radiation exposure limits under normal or emergency conditions. (CFR: 41.12 / 43.4 / 45.10)>>					

Learning Objective(s)

 <OB 1537892(1101)><<Q73 2.3.4 (BL)>>

User (Sys) ID N/A (<OB 1537892(1125)><<1537892>>)

Cross Reference Links

Table: <TB 775424(1301)><<TRAINING - QUESTIONS - Track Questions Modified in this Project (CL-OPS-EXAM-ILT)>>

<TB 776264(1305)><<Tracking link in project CL-OPS-EXAM-ILT to source question 2151242>>
--

Question 74	ID: 2151212	Points: 1.00
-------------	-------------	--------------

<QQ 2151212(1410)><<For the Reactor Core Isolation Cooling (RCIC) system, NPSH / Vortex Limits (Detail Z) are based on which of the following parameters?>>

- A. <QQ 2151212(1480)><<suppression pool level only>>
- B. <QQ 2151212(1480)><<suppression pool level and RCIC flow only>>
- C. <QQ 2151212(1480)><<suppression pool level, suppression pool temperature, and RCIC flow only>>
- D. <QQ 2151212(1480)><<suppression pool level and temperature, RCIC Storage Tank level and temperature, and RCIC flow>>

Answer	<QQ 2151212(1419)><<C>>
--------	-------------------------

Answer Explanation

<QQ 2151212(1412)><<C is correct.

Per Clinton Power Station Emergency Operating Procedures Technical Bases (CPS EOP-TB):

- NPSH and vortex limits are defined for Reactor Core Isolation Cooling (RCIC), High Pressure Core Spray (HPCS), Low Pressure Core Spray (LPCS), and Residual Heat Removal (RHR). The limits apply, however, only when pump suctions are lined up to the suppression pool.
- The NPSH Limit is defined to be the highest suppression pool temperature which provides adequate net positive suction head for pumps taking suction from the suppression pool.
- The Vortex Limit is the lowest suppression pool level at which air entrainment is not expected to occur in the suction of pumps aligned to the suppression pool.
- A suppression pool level of 11 ft. bounds both NPSH and vortex limits for HPCS, LPCS, and RHR.
- RCIC limits are bounded by a combination of suppression pool level, suppression pool temperature, and pump flow.

Incorrect Responses:

A is incorrect but plausible. This response would be correct if RCIC NPSH and Vortex limits were bound by a suppression pool level > 11 ft. ONLY, like HPCS, LPCS, and RHR. However, RCIC NPSH and Vortex limits are bounded by a combination of suppression pool level, suppression pool temperature, and pump flow.

B is incorrect but plausible. This response would be correct if the Vortex Limit ONLY was being taken into account. The Vortex Limit is a plot of suppression pool levels and pump flows. However, since Detail Z includes NPSH and Vortex Limits, suppression pool temperature must also be considered.

D is incorrect but plausible. This response would be correct if RCIC NPSH and Vortex Limits were defined by the level and temperature of either source (RCIC Storage Tank or Suppression Pool) to RCIC in addition to pump flow. However, the limits apply only when pump suctions are lined up to the

suppression pool.>>

Question Information

Topic	<QQ 2151212(1400)><<For the Reactor Core Isolation Cooling (RCIC) system, NPSH / Vortex Limits (Detail Z) are based on >>				
User ID	<QQ 2151212(1404)><<CL-ILT-N19074>>		System ID	<QQ 2151212(1445) ><<2151212>>	
Status	<QQ 2151212(1405) ><<Active>>	Point Value	<QQ 2151212(1441) ><<1.00>>	Time (min)	<QQ 2151212(1408) ><<0>>

Open or Closed Reference	<QQ 2151212(1409)><<CLOSED>>
Operator Type_Cognitive Level	<QQ 2151212(1415)><<RO-MEMORY>>
Operator Discipline	<QQ 2151212(1413)><<LO-I>>
10CFR55 Content	<TB 479395(1305)><<CFR: 41.10 Administrative, normal, abnormal, and emergency operating procedures for the facility.>>

References Provided	None
K/A Justification	Question meets the KA because the candidate must recall the factors that determine RCIC operation within the limits of Detail Z NPSH / Vortex Limits.
SRO-Only Justification	N/A
Additional Information	Question is low cog written at the memory level. The candidate must recall facts from the EOP-TB document (1-F).

NRC Exams Only			
Question Type	Bank (CL-ILT-A12001)	Difficulty	N/A
Technical Reference and Revision #	<ul style="list-style-type: none"> EOP-TB Rev. 7 		
Training Objective	LP87550.01.01 Recall the definition and bases for the following EOP Variables and Curves: .33 Vortex Limit		
Previous NRC Exam Use	None		

K/A Reference(s)

<CM 241985(1002)><<B2.4.17>>	Safety Function 5	Tier 3	Group	RO Imp: 3.9	SRO Imp: 4.3
<CM 241985(1001)><<Knowledge of EOP terms and definitions. (CFR: 41.10 / 45.13)>>					

Learning Objective(s)

 <OB 1537893(1101)><<Q74 2.4.17 (BL)>>
 User (Sys) ID N/A (<OB 1537893(1125)><<1537893>>)

Cross Reference Links

None

Question 75	ID: 2151170	Points: 1.00
-------------	-------------	--------------

<QQ 2151170(1410)><<A reactor startup and heatup is in progress.

The following data was recorded on CPS 9000.06D001Heatup/Cooldown, Inservice Leak And Hydrostatic Testing 30 Minute Temperature Log:

Time	0115	0130	0145	0200	0215	0230	0245	0300	0315
------	------	------	------	------	------	------	------	------	------

RCS Pressure and Temperature									
Reactor Pressure	4	9	13	28	43	45	46	70	105
Steam Dome Temp	221	233	244	268	292	294	296	320	342
Recirc Pmp A Suction	204	212	219	227	235	262	288	316	338
Recirc Pmp B Suction	204	212	219	227	235	262	288	316	338

Vessel Metal Temperature B21-R643									
Vessel Hd Flange	115	117	119	128	136	147	157	169	169
Vessel Bottom Head	168	172	175	180	184	196	207	220	232
Shell Flange	104	106	107	112	117	125	133	141	150
Bottom Hd. Drain	204	209	214	225	235	257	279	301	313

H/U Cooldown Rate °F/hr									
Steam Dome Temp	4	48	44	96	96	8	8	96	88
Recirc Pmp A Suction	12	32	28	32	32	108	104	112	88
Recirc Pmp B Suction	12	32	28	32	32	108	104	112	88

When, if ever, was the Heatup limit first exceeded?>>

- A. <QQ 2151170(1480)><<0230>>
- B. <QQ 2151170(1480)><<0300>>
- C. <QQ 2151170(1480)><<0315>>
- D. <QQ 2151170(1480)><<It has not yet been exceeded.>>

Answer	<QQ 2151170(1419)><<C>>
--------	-------------------------

Answer Explanation

<QQ 2151170(1412)><<C is correct.

Per CPS 9000.06D001Heatup/Cooldown, Inservice Leak And Hydrostatic Testing 30 Minute Temperature Log, the Heatup/Cooldown limit is 100°F/hr.

This violation first occurs when the 0315 log readings are recorded for the Recirc Pmp A/B Suction(s): 338°F - 235°F = 103°F.

Incorrect Responses:

A is incorrect but plausible. This answer would be correct if the (15 minute) calculated heatup rate as recorded in the table was limited to 100°F/hr. However, the actual heatup rate for the previous hour was 50°F (262-212).

B is incorrect but plausible. This answer would be correct if the Heatup/Cooldown limit was 80°F/hr. Per CPS 3002.01 Heatup And Pressurization Limitations, the target heatup rate (HUR) should be less than or equal to 80°F/hr. Even though the actual heatup rate for the previous hour was 89°F (316-227), this is less than the Heatup/Cooldown limit of 100°F/hr.

D is incorrect but plausible. This answer would be correct if Heatup/Cooldown limit was based on four (4) consecutive 15 minute calculated heatup rate reading exceeding the 100°F/hr limit. Since there are only three (3) consecutive readings (0230, 0245 & 0300), the limit would not have been exceeded. However, the actual heatup rate for the previous hour was 103°F (338-235), which is in excess of the Heatup/Cooldown limit of 100°F/hr.>>

Question Information

Topic	<QQ 2151170(1400)><<A reactor startup and heatup is in progress. The following data was recorded on CPS 9000.06D001H>>				
User ID	<QQ 2151170(1404)><<CL-ILT-N19075>>		System ID	<QQ 2151170(1445)><<2151170>>	
Status	<QQ 2151170(1405)><<Active>>	Point Value	<QQ 2151170(1441)><<1.00>>	Time (min)	<QQ 2151170(1408)><<0>>

Open or Closed Reference	<QQ 2151170(1409)><<CLOSED>>
Operator Type_Cognitive Level	<QQ 2151170(1415)><<RO-HIGH>>
Operator Discipline	<QQ 2151170(1413)><<LO-I>>
10CFR55 Content	<TB 479395(1305)><<CFR: 41.10 Administrative, normal, abnormal, and emergency operating procedures for the facility.>>

References Provided	None
K/A Justification	Question meets the KA because the candidate must utilize control room reference material (heatup/ cooldown temperature log) to determine if a violation of heatup rate has occurred.
SRO-Only Justification	N/A
Additional Information	Question is high cog written at the analysis and application level. The candidate must analyze the

	parameters in the stem (heatup/cooldown temperature log) and then apply knowledge to determine if a violation of heatup rate has occurred (3-SPK/SPR).
--	--

NRC Exams Only			
Question Type	New	Difficulty	N/A
Technical Reference and Revision #	<ul style="list-style-type: none"> CPS 9000.06D001 Rev. 30b CPS 3002.01 Rev. 33e 		
Training Objective	LP85804.2.4.47Ability to diagnose and recognize trends in an accurate and timely manner utilizing the appropriate control room reference material.		
Previous NRC Exam Use	None		

K/A Reference(s)

<CM 242015(1002)><<B2.4.47>>	Safety Function 5	Tier 3	Group	RO Imp: 4.2	SRO Imp: 4.2
<CM 242015(1001)><<Ability to diagnose and recognize trends in an accurate and timely manner utilizing the appropriate control room reference material. (CFR: 41.10 / 43.5 / 45.12)>>					

Learning Objective(s)

 <OB 1537894(1101)><<Q75 2.4.47 (NH)>>
 User (Sys) ID N/A (<OB 1537894(1125)><<1537894>>)

Cross Reference Links

None