

A

B

C

D

E

F

G

H

J

A

B

C

D

E

F

G

H

J

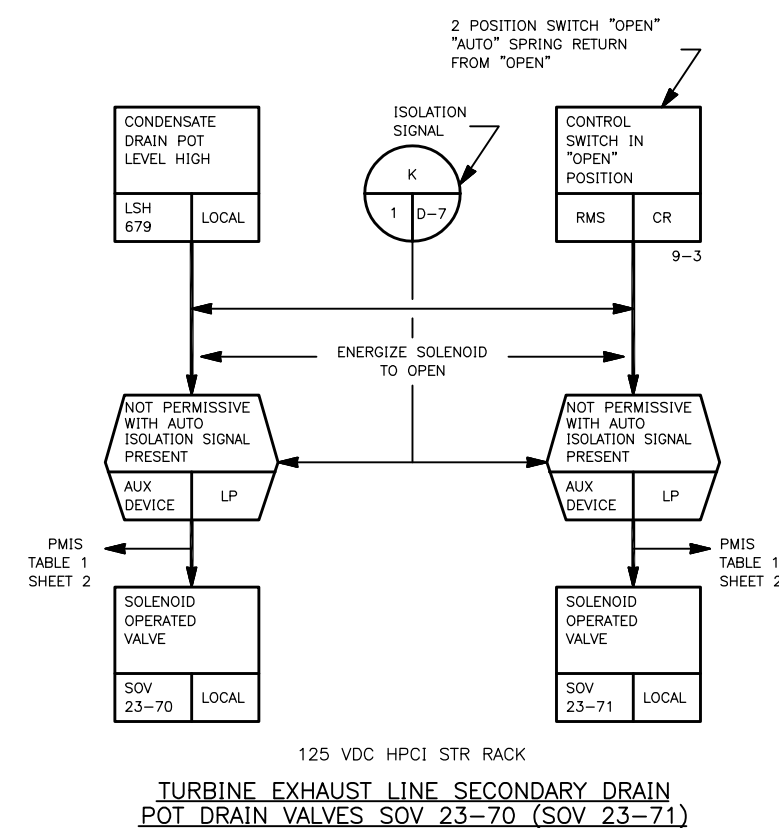
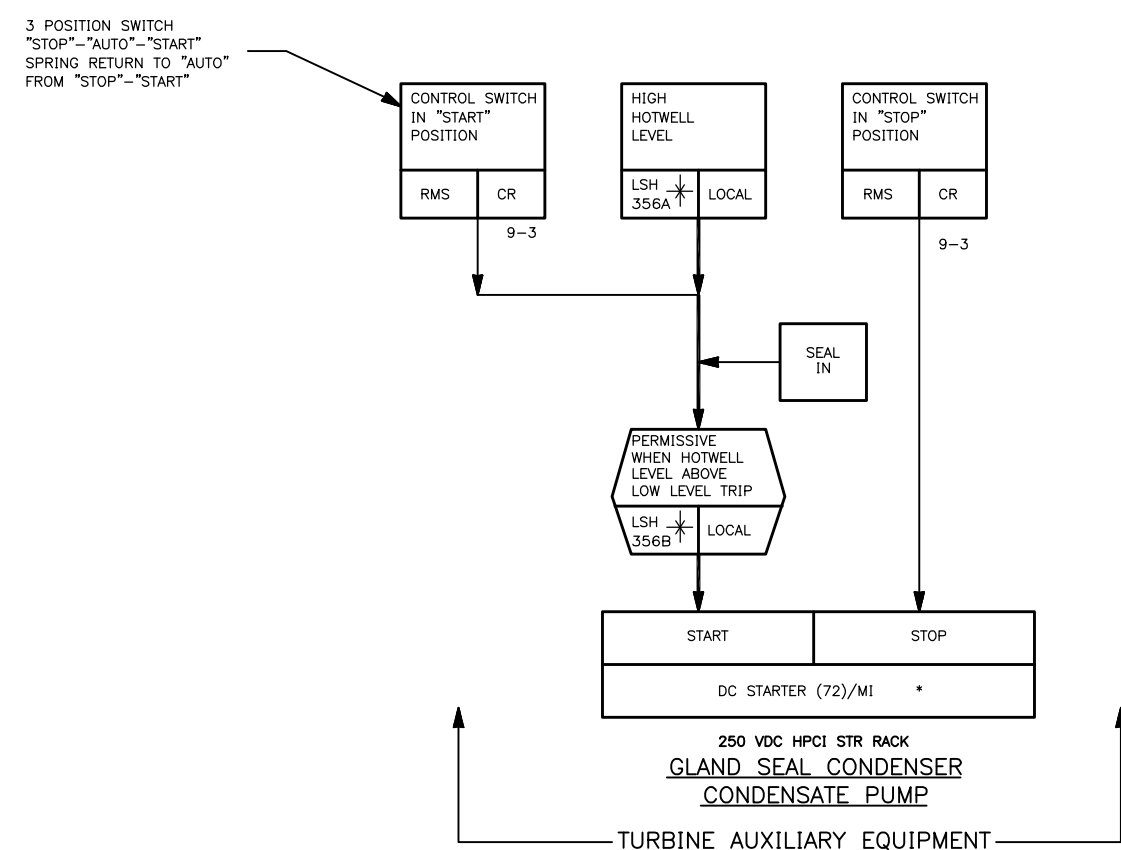
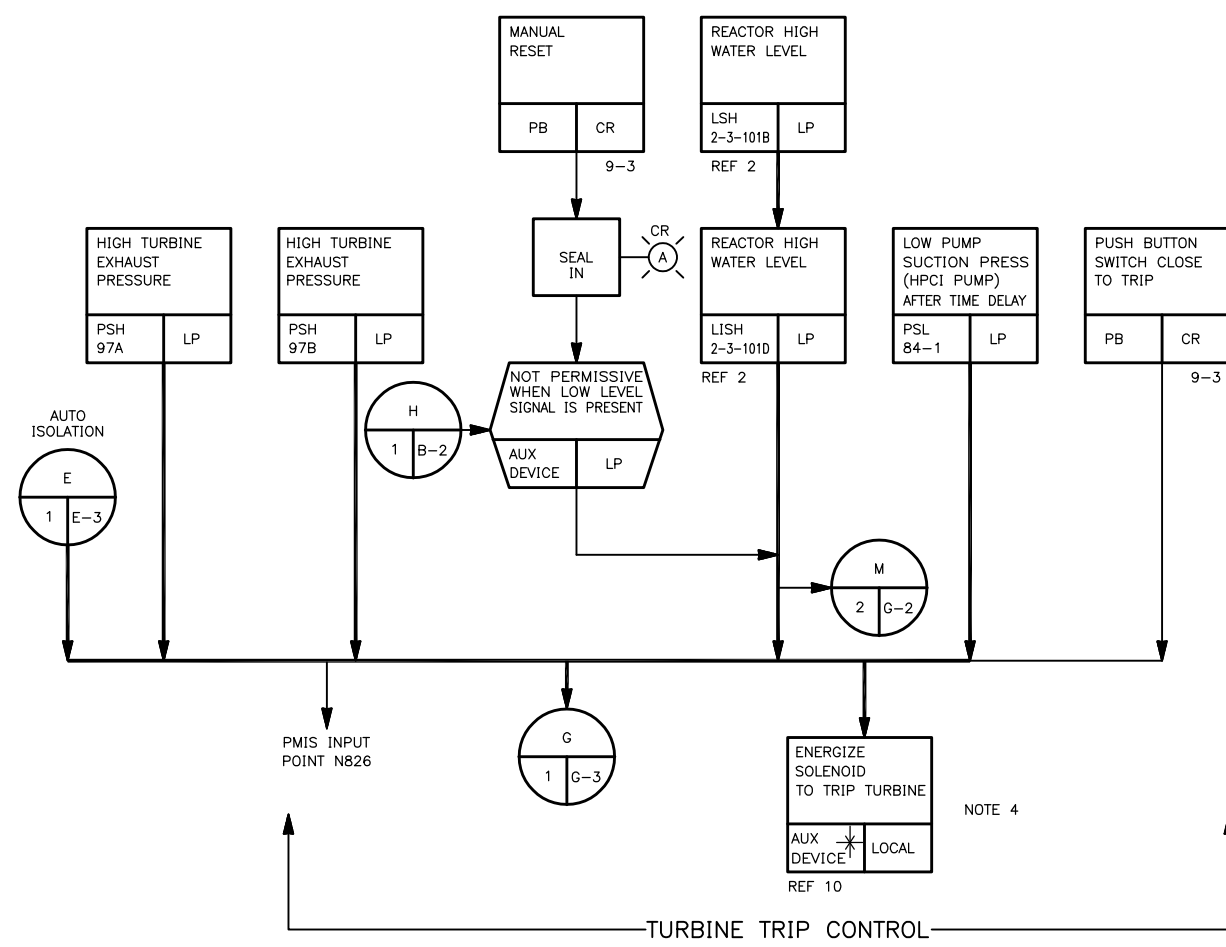
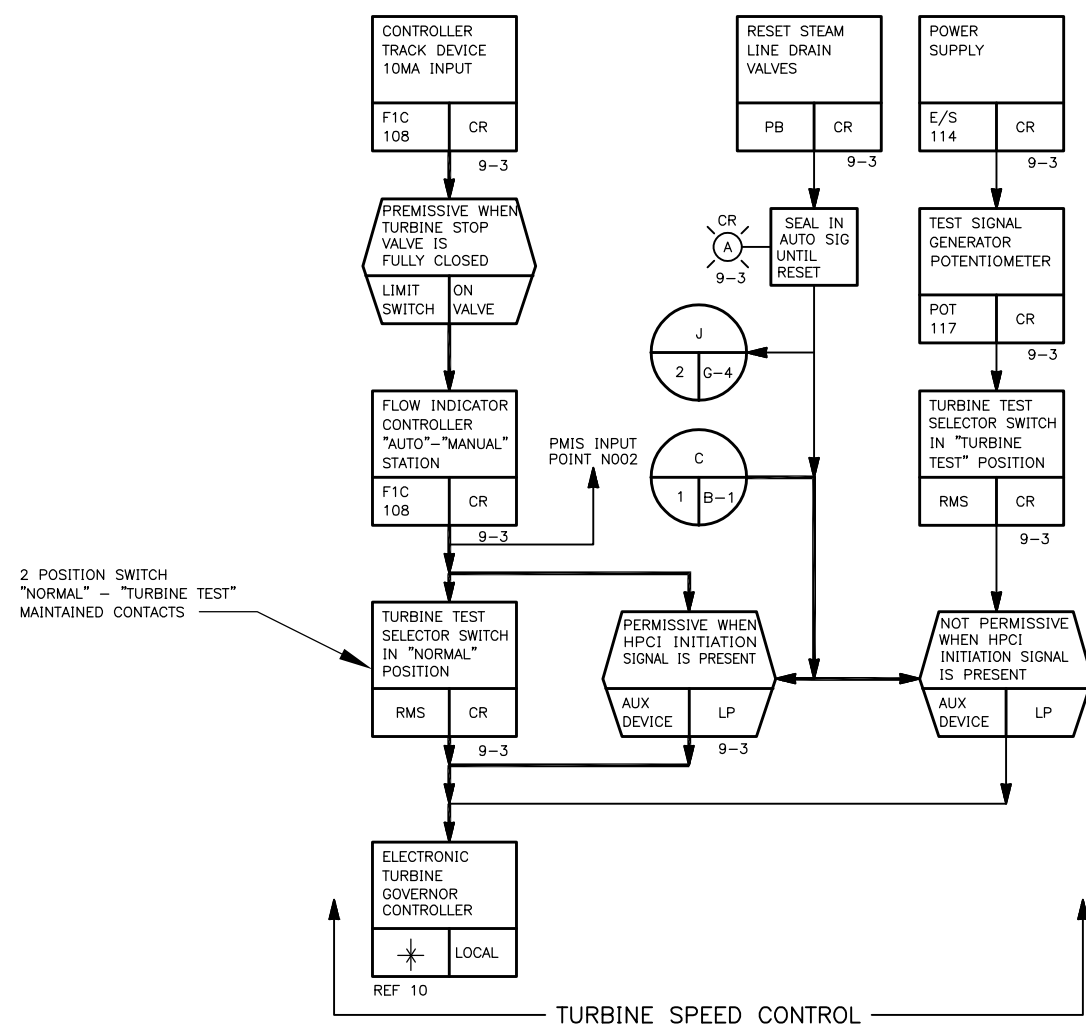

- NOTES:
- FOR GENERAL NOTES AND REFERENCE DRAWINGS SEE SHEET 1.
  - RHR STEAM CONDENSING IS NO LONGER AN OPERATIONAL MODE.

INFORMATION ONLY  
452005104

FOR PREVIOUS REVISIONS, SEE SUPERSEDED CARDS.

REVISIONS BY N.P.P.D.					
NO.	REVISIONS	DFT	CKD	APP	DATE
N04	HPCI SYS GE ELEM DIAG DWG REVIEW (DCN 96-1438)	RAC	JAC	RAR	9-15-97
N05	DCD 01 HP-018 (DCN 96-0330)	JAC	RHG	KG	12-1-97
N06	CED 6029441 (DCN 09-1940)	DLR	SMH	KZ	11-3-10

SIGNIFICANT NUMBER	1	2	3	4	5	6
GROUP						

COOPER NUCLEAR STATION  
HIGH PRESSURE COOLANT INJECTION SYS  
FUNCTIONAL CONTROL DIAGRAM

DRAWN	TRU	DATE	9/24/93
CHECKED	JAC	DATE	10-28-93
APPROVED		DATE	
FILMED	729E589BB SH 3	REVISION	N06

GENERAL ELECTRIC

CARD FILE: C0011076

NO.	REVISIONS
1	
2	
3	
4	
5	
6	
7	
8	
9	
10	
11	
12	