

This drawing and the design it covers are the property of BECHTEL. They are hereby loaned and on the borrower's express agreement that they will not be reproduced, copied, loaned, furnished, or used except in the limited way and private use permitted by any written consent given by the lender to the borrower.

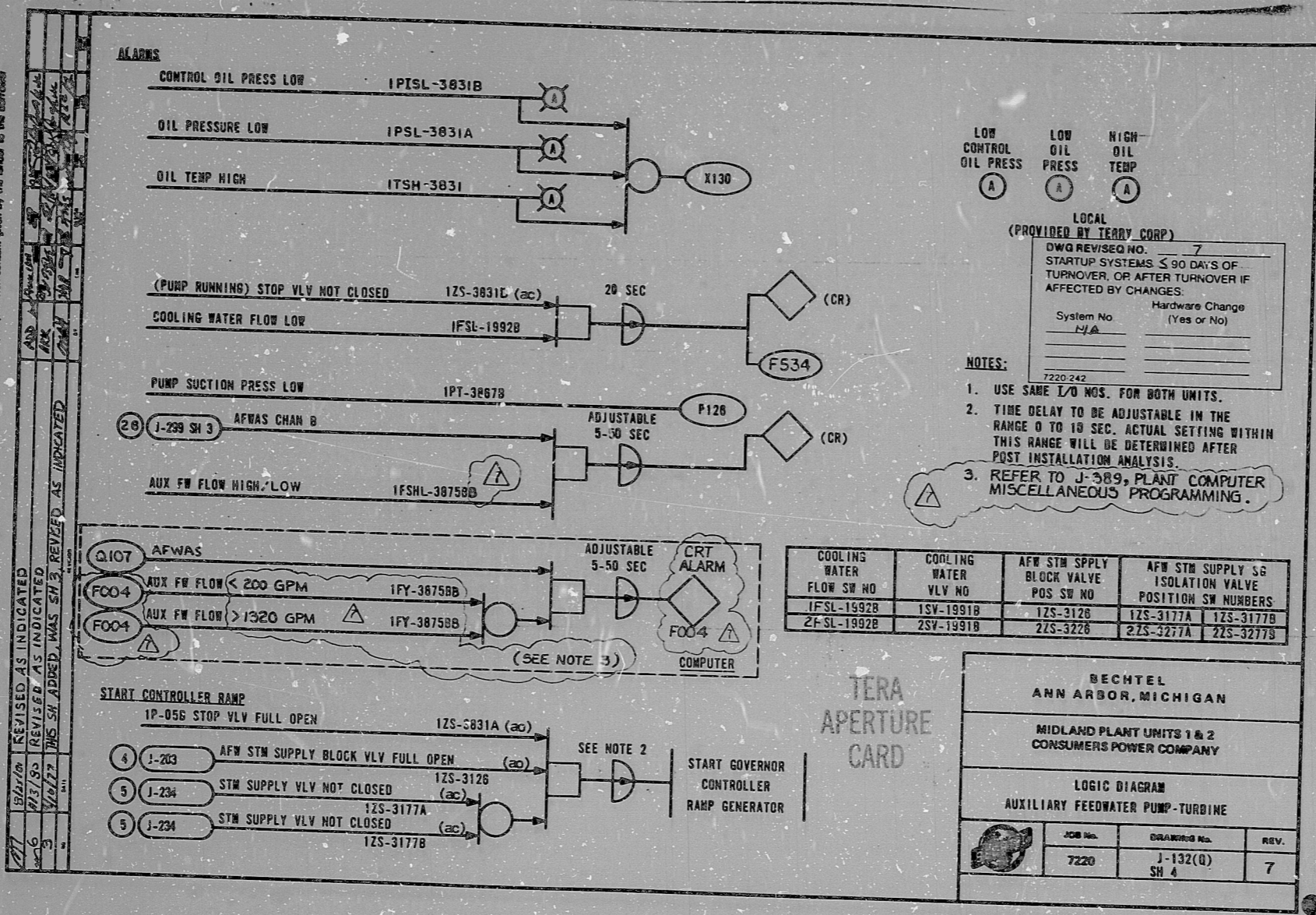

LOW CONTROL OIL PRESS (A)
 LOW OIL PRESS (A)
 HIGH OIL TEMP (A)

LOCAL
 (PROVIDED BY TERRY CORP)
 DWG REVISED NO. 7
 STARTUP SYSTEMS ≤ 90 DAYS OF TURNOVER, OR AFTER TURNOVER IF AFFECTED BY CHANGES.
 System No. N/A
 Hardware Change (Yes or No)

- NOTES:**
- USE SAME I/O NOS. FOR BOTH UNITS.
 - TIME DELAY TO BE ADJUSTABLE IN THE RANGE 0 TO 18 SEC. ACTUAL SETTING WITHIN THIS RANGE WILL BE DETERMINED AFTER POST INSTALLATION ANALYSIS.
 - REFER TO J-389, PLANT COMPUTER MISCELLANEOUS PROGRAMMING.

I certify that the image contained on this frame was made in the normal and regular course of business, on the date stated below and that it is an accurate reproduction of the document submitted to reprographics.

16X

8-26-81 R. Capella
 DATE CAMERA OPERATOR SUPERVISOR OF REPROGRAPHICS

G-1348

RIDS

811120908

