

From: [Kozak, Laura](#)
To: [Lara, Julio](#)
Subject: FW: Clinton Inspection Report
Date: Friday, October 12, 2018 10:03:00 AM
Attachments: [CLI 2018 051.docx](#)

Note to requester: The attachment to this email has been withheld in its entirety under FOIA Ex. B5 (deliberative process privilege).

Draft IR – just FYI

From: Lambert, Kenneth
Sent: Thursday, October 11, 2018 4:33 PM
To: Peralta, Juan <Juan.Peralta@nrc.gov>; Marshfield, Mark <Mark.Marshfield@nrc.gov>
Cc: Casey, Lauren <Lauren.Casey@nrc.gov>
Subject: FW: Clinton Inspection Report

Attached is the Clinton preliminary white letter for HQ review and concurrence. We are looking for a quick turnaround to enable us to meet the NRR metric.

Ken

Ken Lambert
Sr. Enforcement Specialist
Region III
U.S. Nuclear Regulatory Commission
630-810-4376
kenneth.lambert@nrc.gov

From: Wilk, Brenda
Sent: Thursday, October 11, 2018 3:32 PM
To: Lambert, Kenneth <Kenneth.Lambert@nrc.gov>
Cc: Kozak, Laura <Laura.Kozak@nrc.gov>
Subject: Clinton Inspection Report

Hi Ken,

Please see attached Clinton's White Finding. If there are any changes that need to be made on the document please highlight them or whomever from HQ reviewing the document highlight the changes so I can incorporate into the report.

Thank you,

Brenda

Note to requester: The attachments to this email have been withheld in their entirety under FOIA Ex. B5 (deliberative process privilege).

From: [Kozak, Laura](#)
To: [Mitman, Jeffrey](#)
Subject: RE: talk to Clinton
Date: Monday, October 15, 2018 9:31:00 AM
Attachments: [October 15 call with Clinton.docx](#)
[CLI 2018 051.docx](#)

Jeff

Please see my notes for today's call. I am continuing to look at the results to see what else we should bring up.

I also attached the most recent version of the report that I have (this may not reflect all comments/changes).

Laura

From: Mitman, Jeffrey
Sent: Monday, October 15, 2018 9:08 AM
To: Kozak, Laura <Laura.Kozak@nrc.gov>
Subject: RE: talk to Clinton

Works for me. I'll block out the time.

Jeff Mitman

From: Kozak, Laura
Sent: Monday, October 15, 2018 10:06 AM
To: Mitman, Jeffrey <Jeffrey.Mitman@nrc.gov>
Subject: talk to Clinton

FYI – I talked with Joe Edom. He is trying to arrange a discussion today at 3:30pm central, 4:30 pm eastern.

(b)(5)

From: [Wilk, Brenda](#)
To: [Sanchez Santiago, Elba](#); [Stoedter, Karla](#); [Phillips, Charles](#)
Subject: CLI 2018 051
Date: Tuesday, October 16, 2018 10:12:36 AM
Attachments: [CLI 2018 051.docx](#)

Elba,

Please see attached to provide the licensee a copy. The letter has been added to ADAMS.

ML18289A436 for your reference.

Thank you,

Brenda



UNITED STATES
NUCLEAR REGULATORY COMMISSION

REGION III
2443 WARRENVILLE ROAD, SUITE 210
LISLE, ILLINOIS 60532-4352

October 15, 2018

EA-18-104

Mr. Bryan C. Hanson
Senior VP, Exelon Generation Company, LLC
President and CNO, Exelon Nuclear
4300 Winfield Road
Warrenville, IL 60555

SUBJECT: CLINTON POWER STATION—NRC INSPECTION REPORT 05000461/2018051
AND PRELIMINARY WHITE FINDING

Dear Mr. Hanson:

On September 24, 2018, the U.S. Nuclear Regulatory Commission (NRC) presented the preliminary significance assessment results to your staff at Clinton Power Station, Unit 1.

This letter transmits a finding that has preliminarily been determined to be White. A White finding low to moderate safety significance that may require additional NRC inspections. As described in this letter, on May 17, 2018, an apparent violation of Title 10 of the *Code of Federal Regulations* (10 CFR) Part 50, Appendix B, Criterion V, "Instructions, Procedures, and Drawings," and Technical Specification 3.8.2, Condition B.3, were self-revealed for the licensee's failure to follow multiple procedures that affected quality. This resulted in the unavailability and inoperability of the Division 2 Emergency Diesel Generator (EDG) when it was relied upon for plant safety. During part of the time that the Division 2 EDG was unavailable the Division 1 EDG was already out of service for planned maintenance. During the period when neither EDG was available a loss of offsite power would have resulted in a station blackout condition that could have resulted in a long term loss of the ability to cool the reactor core. This finding was assessed based on the best available information, using the applicable Significance Determination Process (SDP). Included in the body of the enclosed inspection report is the basis for the staff's preliminary determination of significance.

Your corrective actions included (1) returning the Division 2 EDG to an operable status; (2) communicating accountability and emphasis on procedure use and adherence; (3) just in time training to all operations department staff on the procedure use requirements; (4) conducting a three-day stand down to discuss case studies and lessons learned; and (5) revising the equipment operator round points to include the EDG starting air manifold pressures. The finding is also an apparent violation of NRC requirements and is being considered for escalated enforcement action in accordance with the Enforcement Policy, which can be found on the NRC's Web site at <http://www.nrc.gov/about-nrc/regulatory/enforcement/enforce-pol.html>.

Enclosure contains Sensitive Unclassified
Non-Safeguards Information. When
separated from attachment 2, this
transmittal document is decontrolled.

In accordance with NRC Inspection Manual Chapter 0609, we intend to complete our evaluation

B. Hanson

- 2 -

using the best available information and issue our final determination of safety significance within 90 days of the date of this letter. The significance determination process encourages an open dialogue between the NRC staff and the licensee; however, the dialogue should not impact the timeliness of the staff's final determination.

Before we make a final decision on this matter, we are providing you with an opportunity to (1) attend a Regulatory Conference where you can present to the NRC your perspective on the facts and assumptions the NRC used to arrive at the finding and assess its significance; or (2) submit your position on the finding to the NRC in writing. If you request a Regulatory Conference, it should be held within 40 days of the receipt of this letter and we encourage you to submit supporting documentation at least one week prior to the conference in an effort to make the conference more efficient and effective. The focus of the Regulatory Conference is to discuss the significance of the finding and not necessarily the root cause(s) or corrective action(s) associated with the finding. If a Regulatory Conference is held, it will be open for public observation. If you decide to submit only a written response, such submittal should be sent to the NRC within 40 days of your receipt of this letter. If you decline to request a Regulatory Conference or to submit a written response, you relinquish your right to appeal the final SDP determination, in that by not doing either, you fail to meet the appeal requirements stated in the Prerequisite and Limitation sections of Attachment 2 of NRC Inspection Manual Chapter 0609.

If you choose to send a response, it should be clearly marked as a "Response to An Apparent Violation; (EA-18-104)" and should include for the apparent violation: (1) the reason for the apparent violation or, if contested, the basis for disputing the apparent violation; (2) the corrective steps that have been taken and the results achieved; (3) the corrective steps that will be taken; and (4) the date when full compliance will be achieved. Your response should be submitted under oath or affirmation and may reference or include previously docketed correspondence, if the correspondence adequately addresses the required response. Additionally, your response should be sent to the U.S. Nuclear Regulatory Commission, ATTN: Document Control Center, Washington, DC 20555-0001 with a copy to K. Stodter, Chief, Branch 1, Division of Reactor Projects, U.S. Nuclear Regulatory Commission, Region III, 2443 Warrenville Road, Suite 210, Lisle, IL 60532-4352, within 40 days of the date of this letter. If an adequate response is not received within the time specified or an extension of time has not been granted by the NRC, the NRC will proceed with its enforcement decision or schedule a Regulatory Conference.

Please contact Ms. Karla Stodter at 630-829-9731, and in writing within 10 days from the issue date of this letter to notify the NRC of your intentions. If we have not heard from you within 10 days, we will continue with our significance determination and enforcement decision. The final resolution of this matter will be conveyed in separate correspondence.

Because the NRC has not made a final determination in this matter, no Notice of Violation is being issued for these inspection findings at this time. In addition, please be advised that the characterization of the apparent violation described above may change as a result of further NRC review.

B. Hanson

- 3 -

This letter will be made available for public inspection and copying at <http://www.nrc.gov/reading-rm/adams.html> and at the NRC Public Document Room in accordance with 10 CFR 2.390, "Public Inspections, Exemptions, Requests for Withholding."

However, the enclosed report contains Security-Related Information, so the enclosed report will not be made publically available in accordance with 10 CFR 2.390(d)(1). If you choose to provide a response that contains Security-Related Information, please mark your entire response "Security-Related Information–Withhold from public disclosure under 10 CFR 2.390" in accordance with 10 CFR 2.390(d)(1) and follow the instructions for withholding in 10 CFR 2.390(b)(1). The NRC is waiving the affidavit requirements for your response in accordance with 10 CFR 2.390(b)(1)(ii).

Sincerely,

/RA/

Patrick L. Loudon, Director
Division of Reactor Projects

Docket No. 50–461
License No. NPF–62

Enclosures:
Inspection Report 05000461/2018051
Attachment 1 (public)
Attachment 2 (non-public)

cc: W. Marsh, Clinton Station Security Manager
A. Khayyat, State Liaison Officer
Illinois Emergency Management Agency

cc w/o attach 2: Distribution via LISTSERV®

B. Hanson

- 4 -

Letter to Bryan Hanson from Patrick Louden dated October 15, 2018

SUBJECT: CLINTON POWER STATION—NRC INSPECTION REPORT 05000461/2018051
AND PRELIMINARY WHITE FINDING

DISTRIBUTION w/attachments:

Daryl Johnson
Niry Simonian
Eric Wharton
Alonzo Richardson
Raymond McKinley
Binoy Desai
Steven West
Darrell Roberts
Jeremy Groom

DISTRIBUTION:

Christopher Cook
RidsNrrDorLpl3
RidsNrrPMClinton Resource
RidsNrrDirslrib Resource
Steven West
Darrell Roberts
Richard Skokowski
Allan Barker
DRSIII
DRPIII
ROPreports.Resource@nrc.gov

ADAMS Accession Number: ML18289A436

OFFICE	RIII	RIII	RIII	OE
NAME	CPhillips:bw	LKozak	JHeller for KLambert	MMarshfield via email for JPeralta
DATE	10/11/2018	10/11/2018	10/12/2018	10/12/2018
OFFICE	NRR	RIII	RIII	
NAME	MFranovich via email	KStoedter	PLouden	
DATE	10/12/2018	10/15/2018	10/15/2018	

OFFICIAL RECORD COPY

U.S. NUCLEAR REGULATORY COMMISSION
REGION III

Docket Numbers: 50-461

License Numbers: NPF-62

Report Number: 05000461/2018051

Enterprise Identifier: I-2018-051-0000

Licensee: Exelon Generation Company, LLC

Facility: Clinton Power Station

Location: Clinton, IL

Dates: August 3 through September 4, 2018

Inspectors: C. Phillips, Project Engineer
L. Kozak, Senior Reactor Analyst
J. Mitman, Senior Reliability and Risk Analyst

Approved by: K. Stoedter, Chief
Branch 1
Division of Reactor Projects

SUMMARY

The U.S. Nuclear Regulatory Commission (NRC) completed the preliminary significance determination associated with an apparent violation in accordance with the Reactor Oversight Process. The Reactor Oversight Process is the NRC’s program for overseeing the safe operation of commercial nuclear power reactors. Refer to <https://www.nrc.gov/reactors/operating/oversight.html> for more information. Findings and violations being considered in the NRC’s assessment are summarized in the table below.

List of Findings and Violations

Failure to Follow Multiple Procedures			
Cornerstone	Significance	Cross-Cutting Aspect	Report Section
Mitigating Systems	Preliminary White AV 05000461/2018050-01 Open EA-18-104	[H.2] – Human Performance, Field Presence	93812–Special Inspection
On August 23, 2018, the NRC issued Inspection Report 05000461/2018050 which discussed a self-revealed finding with a To-Be-Determined (TBD) significance and an associated Apparent Violation of Title 10 of the Code of Federal Regulations (10 CFR) Part 50, Appendix B, Criterion V, “Instructions, Procedures, and Drawings,” and Technical Specification 3.8.2, Condition B.3. The issue involved the licensee’s failure to follow multiple procedures that affected quality which resulted in the unavailability and inoperability of the Division 2 Emergency Diesel Generator when it was relied upon for plant safety.			

Additional Tracking Items

None.

INSPECTION SCOPE

Inspections were conducted using the appropriate portions of the inspection procedure (IP) in effect at the beginning of the inspection unless otherwise noted. Currently approved IPs with their attached revision histories are located on the public website at <http://www.nrc.gov/reading-rm/doc-collections/insp-manual/inspection-procedure/index.html>. Samples were declared complete when the IP requirements most appropriate to the inspection activity were met consistent with Inspection Manual Chapter (IMC) 2515, “Light-Water Reactor Inspection Program - Operations Phase.” The inspectors reviewed selected procedures and records, observed activities, and interviewed personnel to assess licensee performance and compliance with Commission rules and regulations, license conditions, site procedures, and standards.

OTHER ACTIVITIES—TEMPORARY INSTRUCTIONS, INFREQUENT AND ABNORMAL

93812—Special Inspection

The purpose of this inspection was to complete the preliminary significance determination for an apparent violation 10 CFR Part 50, Appendix B, Criterion V and Technical Specification 3.8.2, Condition B.3. documented in NRC Special Inspection Report 05000461/2018050.

INSPECTION RESULTS

93812—Special Inspection

Failure to Follow Multiple Procedures			
Cornerstone	Significance	Cross-Cutting Aspect	Report Section
Mitigating Systems	Preliminary White AV 05000461/2018050-01 Open EA-18-104	[H.2] – Human Performance, Field Presence	93812–Special Inspection
On August 23, 2018, the NRC issued Inspection Report 05000461/2018050 which discussed a self-revealed finding with a To-Be-Determined (TBD) significance and an associated Apparent Violation of Title 10 of the <i>Code of Federal Regulations</i> (10 CFR) Part 50, Appendix B, Criterion V, “Instructions, Procedures, and Drawings,” and Technical Specification 3.8.2, Condition B.3. The issue involved the licensee’s failure to follow multiple procedures that affected quality which resulted in the unavailability and inoperability of the Division 2 Emergency Diesel Generator when it was relied upon for plant safety.			
<u>Description:</u> On April 30, 2018, the licensee shut down the reactor as part of a scheduled refueling outage. During the outage, the licensee performed maintenance on the Division 2 electrical system which required the Division 2 emergency diesel generator (EDG) to be removed from service. From May 9-11, 2018, the licensee completed activities to restore the Division 2 EDG to service. Due to the failure to follow multiple procedures (as discussed in NRC Inspection Report 05000461/2018050), the Division 2 EDG was not restored to an operable status because operations personnel had not repositioned starting air valves 1DG160 and 1DG161			

from the closed position to the open position. With the starting air valves in the closed position, the Division 2 EDG was unable to start if needed.

On May 14, 2018, at 12:30 a.m., since the licensee was unaware that the Division 2 EDG was inoperable and unavailable due to its inability to start caused by the 1DG160 and 1DG161 valves being closed, the licensee began a Division 1 scheduled maintenance window. As a result of taking the Division 1 480 VAC bus out of service, the Division 1 EDG was declared inoperable.

On May 17, 2018, at 3:03 p.m., a non-licensed operator performing shift rounds identified that the 1DG160 and 1DG161 valves were closed and reported this condition to the control room. The licensee declared the Division 2 EDG inoperable, investigated the condition, and subsequently returned the Division 2 EDG to an operable status.

Corrective Actions: The licensee initiated several corrective actions including (1) communicating accountability and emphasis on procedure use and adherence; (2) just in time training to all operations department staff on the procedure use requirements; (3) conducting a three-day stand down to discuss case studies and lessons learned; and (4) revising the equipment operator round points to include the EDG starting air manifold pressures.

Corrective Action Reference: Action Request (AR) 4138790, "Division 2 DG Air Receiver Found Isolated Rounds," dated May 17, 2018.

Performance Assessment:

Performance Deficiency: The licensee failed to perform activities affecting quality in accordance with prescribed procedures and work instructions as required by 10 CFR Part 50, Appendix B, Criterion V, "Instructions, Procedures and Drawings," that resulted in the unavailability of the Division 2 EDG when it was relied upon for plant safety.

Screening: The inspectors determined the performance deficiency was more than minor because it adversely affected the configuration control attribute of the Mitigating Systems Cornerstone and its objective of ensuring the availability, reliability, and capability of systems that respond to initiating events to prevent undesirable consequences. Specifically, the failure to follow station procedures/work instructions resulted in the unavailability of the Division 2 EDG when it was relied upon for plant safety.

Significance: The inspectors evaluated the finding against the guidance of IMC 0609 Appendix G, Attachment 1, "Shutdown Operations Significance Determination Process Phase 1 Initial Screening and Characterization of Findings." The finding impacted the Mitigating Systems Cornerstone, specifically the Electric Power Availability Safety Function. The finding represented a loss of system safety function for the EDGs for greater than its TS 3.8.2, Condition B.3, allowed outage time of "Immediately" (one of the two EDGs was required to be returned to an operable status immediately) which required a Phase 2 Appendix G evaluation.

The Phase 2 evaluation was conducted using IMC 0609 Appendix G, Attachment 3, and "Phase 2 Significance Determination Process Template for BWR during Shutdown." A Region III senior reactor analyst (SRA) completed the Phase 2 evaluation and concluded that a Phase 3, or detailed risk evaluation, would be needed to refine the Phase 2 evaluation.

Summary from Special Inspection Report

The detailed risk evaluation (DRE) covered a 6.5 day period when the Division 2 EDG was inadvertently unavailable during a refueling outage.

The Division 2 EDG had been inoperable and unavailable as part of planned Division 2 480 VAC electrical distribution and Emergency Service Water (SX) systems maintenance activities. When the Division 2 systems work was completed and the systems restored on May 11, 2018 (at 2:30 a.m.), operators incorrectly declared the Division 2 EDG available. At this time, the Division 2 EDG starting air isolation valves (1DG160 and 1DG161) remained closed, which would prevent starting air from reaching the EDG air start motors, making the EDG inoperable, unavailable, and non-functional because it would not and could not be started on any demand signal.

On May 14, 2018, at 12:30 a.m., as the licensee was unaware that the Division 2 EDG was unavailable, the licensee began a scheduled maintenance window on the Division 1 480 VAC bus 1A1. As a result of taking the bus out of service, the Division 1 EDG was declared inoperable. At this time neither Division 1 nor 2 EDG was functional.

On May 17, 2018, at 3:03 p.m., a non-licensed operator performing shift rounds identified the 1DG160 and 1DG161 valves were inappropriately closed and reported this condition to the control room. The licensee declared the Division 2 EDG inoperable and investigated the condition. The licensee restored the valves to the open position and declared the Division 2 EDG available at 3:45 p.m. After the licensee performed OP-AA-108-106, the licensee declared the Division 2 EDG operable at 9:04 p.m.

During the 6.5 day period the Division 2 EDG was not operable, available, or functional as the licensee expected. During the 3.5 day period from May 14th to May 17th, neither the Division 1 nor 2 EDG was available to deal with a Loss of Offsite Power (LOOP) if one occurred.

As described in Inspection Report 2018050, a Phase 1 Significance Determination Process (SDP) screening and a phase 2 SDP evaluation were completed for the finding using the guidance of IMC 0609 Appendix G, "Shutdown Operations Significance Determination Process". As a result, the NRC determined that a detailed risk evaluation was needed to further evaluate recovery strategies. These strategies included 1) restoration of the Division 2 EDG; 2) plant-specific mitigating system strategies such as the Division 3 cross-tie to Division 2; 3) use of Diverse and Flexible Coping Strategies (FLEX), and 4) the recovery of offsite power. As a result the inspection report initially characterized the significance of this finding as "to be determined."

Summary of Preliminary (Phase 3) Significance Determination

The Clinton SPAR model, revision 8.54 was modified to add a shutdown Mode 4 cold shutdown Loss of Offsite Power (LOOP) event tree based on the existing Grand Gulf shutdown SPAR model. The model was further modified to use Clinton specific system fault trees and to refine diesel generator recovery, incorporate FLEX electrical, FLEX suppression pool cooling, FLEX injection, potential recovery of high pressure core spray (HPCS) pump, recovery of reactor core isolation cooling (RCIC), use of alternate injection systems such as installed fire pumps, B.5.b fire pumps, B.5.b reactor depressurization methods, manual containment venting capability, and the cross-tie of the Division 3 EDG to Division 2 electrical

distribution system. Human error probabilities in addition to equipment failure probabilities were added for all actions requiring manual alignment and operation.

The detailed risk evaluation considers the many different core cooling methods potentially available. However, the results indicate that successful mitigation of the event relies on operator action to restore AC power by one of several methods – recovery of the Division 2 EDG, FLEX electrical, Division 3 to Division 2 cross-tie, or offsite power recovery. The analysis is complex since mitigation of a LOOP event in the degraded condition significantly relies on operator actions and the decision making involving the interaction of these four recovery strategies. The risk results are driven by human error.

None of the many operator actions modeled to mitigate the postulated LOOP/SBO event were assumed to be resource limited. This is in recognition that the plant was in a refueling outage with extra operations, maintenance and engineering staff available. Few of the many actions modeled to mitigate the postulated LOOP/SBO were assumed to be limited by time available. However, the overall sequence was modeled assuming operators have one hour to recover the Division 2 EDG before an extended loss of AC power (ELAP) is declared. Once ELAP is declared, plant procedures direct the operators to pursue the FLEX method to re-power Division 2. If FLEX fails, procedures supply guidance on using the Division 3 cross-tie. For the dominant core damage sequence, the time to core damage is approximately 13 hours, this was considered to be adequate time with some margin, but not extra or expansive time, given the level of manual effort required and the number of concurrent methods of mitigation that were modeled.

The finding exposure time that was quantitatively assessed was the 3.5 day period that both emergency diesel generators were unavailable. The full exposure time was approximately 6.5 days. However, the risk results are dominated by the 3.5 days when neither diesel was available.

The result of the detailed risk evaluation is a finding of low to moderate safety significance (White). The best estimate change (i.e., delta) in core damage frequency for the 3.5 day period, using reasonable and realistic assumptions, was estimated to be $3.8E-6$ per year. The dominant sequence was a loss of offsite power, failure to recover the Division 2 EDG leading to an Extended Loss of AC Power (ELAP) declaration, failure to maintain the reactor depressurized, failure to inject at high pressure, and the failure to cross-tie the Division 4KV bus to the Division 2 4kV bus. Sensitivity evaluations were performed to understand the influence of important assumptions. The results of the sensitivity evaluations showed a range of outcomes from very low safety significance (Green) to substantial safety significance (Yellow). The sensitivity evaluations were used to confirm the best estimate outcome – low to moderate (White) safety significance. See Table 1. The specific important assumptions of the detailed risk evaluation, the event tree, fault trees, and dominant core damage cut-sets are included in the Enclosure.

Table 1: Risk Results Including Sensitivity Cases

	Notes	BE Adjusted	Old BE Value	New BE Value	Delta CDF Results	
Best Case Analysis		n/a	n/a	n/a	3.8E-06	
Sensitivity Cases:						
1	Div. 2 EDG available (i.e., no PD)	No change set required, simply use value for base case no PD	EPS-XHE-XR-DG1B	TRUE (1.0)	1.00E-03	5.4E-07
2	Div. 2 EDG non-recovery based on data 88%		EPS-XHE-LR-NR10H	2.0E-02	8.80E-01	1.7E-05
3	Div. 2 EDG non-recovery based Exelon estimate	Note that using Exelon's values reduces the CDF to less than the no PD case because the NRP is lower than the base EDG failure probability	EPS-XHE-LR-NR10H	2.0E-02	5.0E-03	1.0E-07
4	HPCS pump available during entire 3.5 day exposure time		HCS-XHE-XR-MDP	TRUE (1.0)	False (0.0)	6.2E-07
5	Single Human Error Probability (HEP) for all injection methods		Multiple BE	5.3E-05	1.0E-03	3.5E-06
6	Decrease RCIC HEP to 0.1		SD-XHE-XM-FRCIC	7.5E-01	1.0E-01	3.7E-06
7	Decrease FLEX Electrical HEP to Exelon value to 0.1		SD-XHE-XM-FELEC	2.5E-01	1.0E-01	2.4E-06
8	Reduce all FLEX HEPs by factor of 10		Multiple BE	Various	Decrease by 10X	6.7E-08
9	Set all FLEX HEPs to False (0.0)		Multiple BE	Various	False (0.0)	2.5E-08
10	Increase all FLEX HEPs by Factor of 2	Increase RCIC value from 0.75 to 1.0	Multiple BE	Various	Increase by 2X	2.9E-05
11	Using Exelon Initiating Event Frequency (IEF) of 0.12 per year	Exelon modified the IEF because the switchyard was protected Note: EDG2 was protected during 6.5 days of unavailability	SD-MFL-LOOP	1.7E-1	1.2E-1	2.8E-06

Cross-cutting Aspect: As discussed in Inspection Report 05000461/2018050, the finding had a cross-cutting aspect in the Field Presence component of the Human Performance cross-cutting area. (H.2)

Enforcement:

Apparent Violation: Title 10 CFR Part 50, Appendix B, Criterion V, "Instructions, Procedures, and Drawings," requires, in part, that activities affecting quality be prescribed by documented procedures of a type appropriate to the circumstances and be accomplished in accordance with these procedures.

Clearance Order 139455 instructions required the performance of CPS 3506.01P002, "Division 2 Diesel Generator Operations," Revision 3a, in conjunction with the removal of out-of-service tags on May 9, 2018.

Procedure OP-AA-108-103, "Locked Equipment Program," Revision 2, Step 4.1.5, stated, "If plant conditions require a locked component to be positioned in a manner other than that indicated on the locked equipment checklist or approved procedure, then UNLOCK and REPOSITION equipment in accordance with OP-AA-108-101, "Control of Equipment and System Status." Procedure OP-AA-108-101, "Control of Equipment and System Status," Revision 14, Step 4.1.1.1, stated, "Utilize an ACPS for aligning equipment outside of routine operations."

Procedure OP-AA-108-106, "Equipment Return to Service," Revision 5, Step 4.3, required that "if equipment will not be restored to the Equipment Line-up/Restoration position or the original condition, then another approved equipment status control mechanism shall be used to document equipment status (i.e. Equipment Status Tag, administrative clearance/tagout). Procedure OP-AA-108-101, 'Control of Equipment and System Status,' shall be used to document abnormal equipment configuration and shall be immediately applied following equipment restoration."

Procedure OP-AA-108-106, "Equipment Return to Service," Revision 5, Step 4.4.9, which stated, "Applicable Operating procedures are complete and any equipment line-ups directed to be completed by the Operating Procedures are completed."

Procedure OP-AA-108-106, "Equipment Return to Service," Revision 5, Step 4.4.14, stated, "The system/equipment has been walked down as appropriate to verify that it can be safely operated to fulfill its design function."

Procedure OP-AA-109-101, "Clearance and Tagging," Revision 12, Step 10.2.1 stated, "If a lift position is determined to be different from the normal lineup position for the present plant condition and not tracked by another C/O or procedure, then the Shift Management shall be notified and equipment tracking initiated."

Technical Specification 3.8.2, "AC Sources-Shutdown," Condition B.3, states, in part, that an inoperable EDG be restored to an operable status immediately.

Between May 9 and May 17, 2018, the licensee apparently failed to:

Perform CPS 3506.01P002, "Division 2 Diesel Generator Operations," Revision 3a, in

conjunction with the removal of C/O 139455 as required by the C/O restoration instructions.

Perform OP-AA-108-103, "Locked Equipment Program," Revision 2, Step 4.3, valves 1DG160 and 1DG161 were normally locked open valves and an ACPS was not utilized to track valve status.

Perform OP-AA-108-106, "Equipment Return to Service," Revision 5, Step 4.3, when valves 1DG160 and 1DG161 were left in an abnormal position an approved equipment status control mechanism was not used to track equipment status.

Perform OP-AA-108-106, "Equipment Return to Service," Revision 5, Step 4.4.9, when the equipment was declared operable the applicable operating procedure CPS 3506.01P002 had not been completed and equipment line-ups directed to be completed by the operating procedures were not completed.

Perform OP-AA-108-106, "Equipment Return to Service," Revision 5, Step 4.4.14, when the system was declared operable without being walked down.

Perform OP-AA-109-101, "Clearance and Tagging," Revision 12, Step 10.2.1, when the lift position was different from the normal lineup for the present plant condition and equipment tracking was not initiated.

Additionally, because the licensee was not aware of the EDG's inoperability the required action in Technical Specification 3.8.2, Condition B.3 was not followed.

EXIT MEETINGS AND DEBRIEFS

The inspectors confirmed that proprietary information was controlled to protect from public disclosure. No proprietary information was documented in this report.

- On September 24, 2018, Mr. P. Loudon presented the preliminary significance assessment results to Mr. T. Stoner, Clinton Power Station, Site Vice President.

DOCUMENTS REVIEWED

93812—Special Inspection

Detailed Risk Evaluation Assumptions

Plant Conditions during the Conditions Assessed

Clinton is a General Electric Boiling Water Reactor 6 with a Mark III containment. It has three divisions of Emergency Core Cooling (ECCS). Divisions 1 and 2 have residual heat removal (RHR) capability, each with an RHR train that contains a heat exchanger. Each division has its own emergency diesel generator (EDG) and 4kV safety bus. In addition, Division 3 contains a High Pressure Core Spray (HPCS) pump dedicated safety bus, and EDG₃ but does not contain an RHR train.

The Division 2 EDG unplanned unavailability started after the reactor had been refueled and the associated reactor cavity was full. That is, there was over 23 feet of water above the reactor core. Early in the unavailability, the licensee installed the reactor pressure vessel (RPV) internals, lowered water level to about six inches below the RPV flange, installed and tensioned the reactor vessel head. The unit entered cold shutdown or Mode 4 when the last reactor head bolt was tensioned. See Figure 1 for a time line of these events.

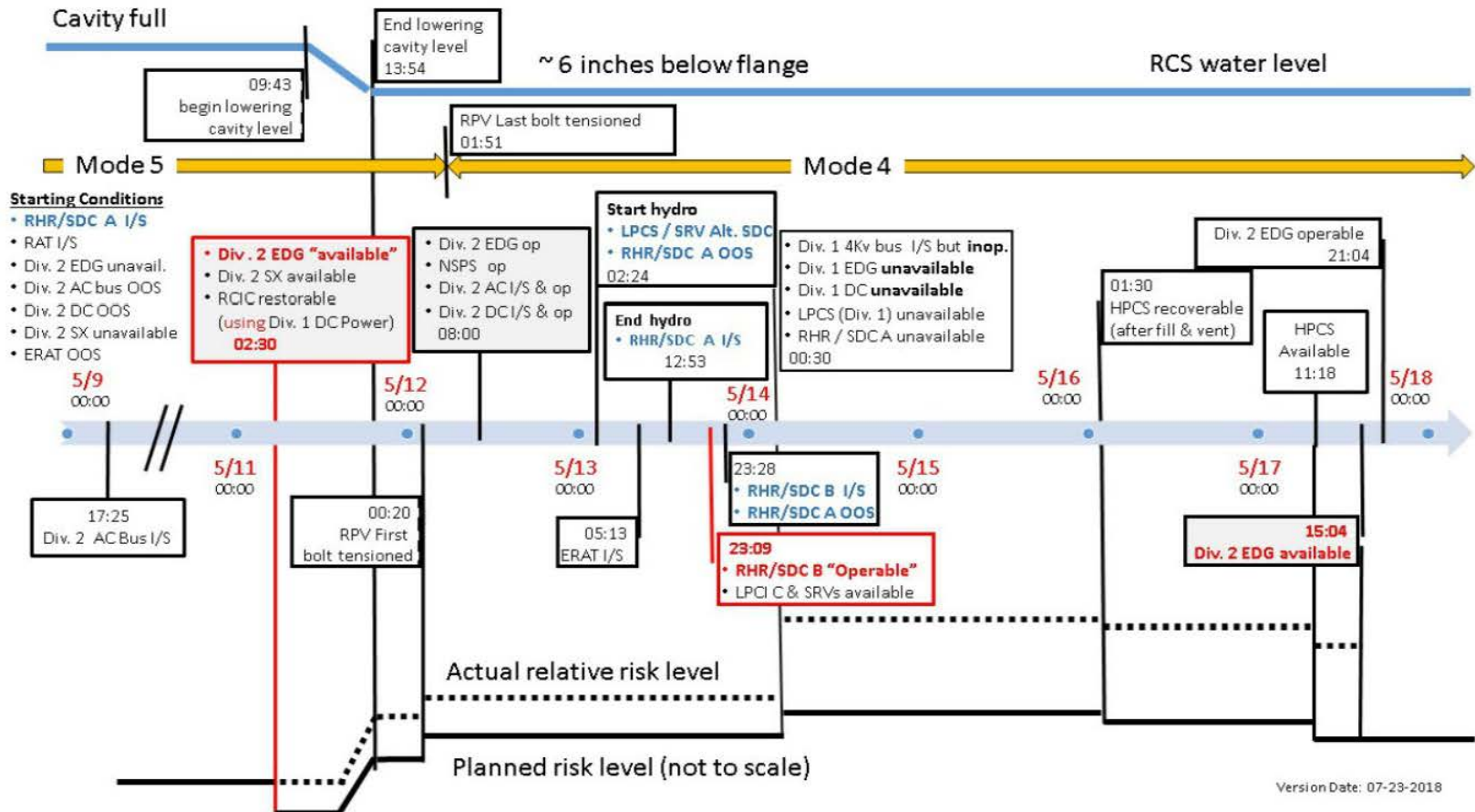

The following assumptions were made in performing the detailed risk evaluation.

1. The time to boil in the reactor coolant system was assumed to be approximately 4 hours, based on Exelon document CL-SDP-010 Rev. 1. This calculation assumes the starting water level is approximately six inches below the RPV flange.
2. The time to top of active fuel, a surrogate for core damage, varies from approximately 10 to 24 hours depending on plant configuration assumptions. These values were based on Exelon document CL-SDP-010 Rev. 1. If the reactor is maintained at low pressure, then the time to core uncover is about 24 hours. If the reactor pressure increases then the time to uncover is estimated between 10 and 13 hours. Both calculations assume the starting water level is approximately six inches below the RPV flange.
3. Core uncover is the normal at-power surrogate for core damage. During shutdown, core damage is expected between 1/3 and 2/3 core height which is somewhat after core uncover, therefore, using core uncover as a surrogate for core damage is conservative.
4. The following equipment was out of service and was considered to be unavailable and non-recoverable:
 - EDG 1A;
 - 480v AC bus 1A;
 - 480v AC bus A;
 - NSPS 120v Power distribution panel bus A;
 - Division 1 normal 125v DC battery charger 1A; and
 - RHR pump A.
5. The following equipment was available:
 - All FLEX equipment;
 - RHR train B;
 - RHR heat exchanger A;
 - Both suppression pool cleanup (SF) pumps and the associated piping (Note: there was a very short period at the beginning of the 3.5 days when one SF pump was not available. Because this availability was short and with the knowledge that the results are not driven by mitigating system availability, this unavailability was ignored.);
 - All B5b equipment;
 - 480v AC aux. building bus 1L;
 - 480v AC aux. building bus 1M;
 - 480v AC aux. building bus 1D;
 - 480v AC aux. building bus 1E (feed to 125v DC battery charger 1F); and
 - 125v DC battery (swing) charger 1F (feed from 480v AC aux. building bus 1E).
6. The NRC used the SPAR-H Human Reliability Method to evaluate the many operator actions in the model. For all of the human error probabilities evaluated, the performance shaping factor “stress” was considered to be “high” for both diagnosis and action because the plant would be in a station blackout condition. In many of the Human Error

Probability (HEP) evaluations, “complexity” was determined to be either “moderate” or “high” because the operators would be in multiple procedures in multiple plant locations. Many of the actions are local, infrequently or never performed, and some have very limited training. In many cases, “ergonomics” was also rated as “poor” because the local actions may be physically demanding and in difficult SBO conditions (on emergency lighting at best and without any ventilation). Table 2 below contains a summary of the dominant HEPs.

7. None of the many actions modeled to mitigate the postulated LOOP/SBO event were assumed to be resource limited. This is in recognition that the plant was in a refueling outage with extra operations, maintenance and engineering staff available. The detailed risk evaluation models operator action for four different methods to re-establish electrical power to Division 2 (EDG recovery, offsite power recovery, FLEX, Division 3 to Division 2 crosstie), two additional (beyond the normal use of SRVs after restoring emergency power) methods to maintain the reactor de-pressurized (FLEX and B.5.b), three additional methods (beyond using ECCS after restoring emergency power) to inject to the Reactor Coolant System (RCS) at low pressure (two FLEX methods and the diesel driven fire pumps), two methods to inject to the RCS at high pressure (HPCS and RCIC), and two additional methods to remove decay heat (FLEX suppression pool cooling and containment venting). All of these require operator action. Many require significant operator effort. In addition to these actions there are other important, non-modeled actions that would also be in progress, such as actions to establish primary and secondary containment and actions for emergency response such as accountability and notifications.
8. Few of the many actions modeled to mitigate the postulated LOOP/Station Black Out (SBO) were assumed to be limited by time available. However, the overall sequence was modeled assuming operators have 1 hour to recover the Division 2 EDG before ELAP is declared. Once ELAP is declared, operators will pursue the FLEX method to re-power Division 2. If FLEX fails, the Division 3 cross-tie, is modeled. For the dominant sequence, the time to core damage is approximately 13 hours, this was considered to be adequate time with some margin, but not extra or expansive time, given the level of manual effort required and the number of concurrent methods of mitigation that were modeled.
9. The high pressure core spray system was unavailable during most of the 3.5 day exposure period due to planned maintenance. Initially, for a period of 49 hours, it was not recoverable. Later, for a duration of 34 hours, it was modeled as recoverable, and in the last 4.5 hours of the exposure period, the system was fully available. The impact of the status of HPCS over the exposure period was addressed by running three separate cases – HPCS unavailable, HPCS recoverable, and HPCS at nominal failure probabilities. The results were combined in a spreadsheet to obtain the final result. To estimate the HEP for the operator failure to recover HPCS during the 44 hours it was recoverable, the performance shaping factors that were determined to be performance drivers were stress for diagnosis, and stress and complexity for action. Stress was evaluated as “high” because the plant would be in a station blackout condition. Complexity was rated as “moderate”. Under normal conditions, this would not be a complex task, but in response to a station blackout with multiple procedures and mitigating strategies in progress, complexity is increased.

10. The RCIC system was unavailable due to plant conditions. During the 3.5 days of interest, the plant was in cold shutdown with reactor coolant system water level above the steam lines. However, the RCIC system was not undergoing any maintenance and could have been put into service if an event had occurred, steam was available due to RCS heat-up and boiling, and water level had decreased below the steam line. While possible, extensive work would be required to prepare the RCS for operations at normal pressure and temperature. Licensee procedure CPS 3002.01 controlled this process. This 40 page document is the normal startup procedure. It assumes normal electrical power is available to realign systems. While much of this procedure would not be required to prepare the RCS for RCIC operation and extensive amount of procedure triage would be required. The HEP for the operator failure to put RCIC into service under the postulated conditions is $7.5E-1$. The HEP was dominated by failure to perform the action. The performance drivers were considered to be time (this is one of the few HEPs that was impacted by time available), stress, complexity, experience/training, and ergonomics. The time available was assumed to be about equal to the time required, stress was considered to be "high", complexity was "high", experience/training was "low", and ergonomics was "poor".
11. Electrical power recovery to Division 2 could be successful via offsite power recovery, recovery of Division 2 diesel generator, use of FLEX, or crosstie of the Division 3 diesel generator to the Division 2 4kV bus. The detailed risk evaluation assumes that the operators will initially try to recover the diesel generator. If recovery is not successful, operators will transition to FLEX implementation, and if FLEX fails, the evaluation models the potential to implement the crosstie.
12. The Division 2 EDG was recoverable and the risk evaluation shows that the operators would be very likely to recover it. However, the potential for operators failing to recover the diesel generator was evaluated. The failure to recover the diesel generator was assigned a human error probability of 0.202 (20 percent failure, 80 percent success rate). This is a factor of 4 lower than the data/statistically derived failure to recover probability. The NRC assumed that 1 hour was available to recover AC power to Division 2 by recovering the EDG. At 1 hour, ELAP declaration and implementation of FLEX electrical power to Division 2 would commence. Diesel generator recovery is further complicated by station blackout load shedding that removes all DC control power from the diesel generator and the FLEX electrical alignment which also impacts Division 2 EDG components. Recovery of the Division 2 EDG after 1 hour into an SBO does not represent successful recovery of Division 2 AC power. Operator actions to back out of ELAP, FLEX implementation, and load shedding to restore the EDG is not governed by procedures, is not a simple, skill of the craft task, and has no training. It was not credited in the risk evaluation consistent with general PRA/HRA assumptions and the Risk Assessment Standardization Project (RASP) guidance.
13. The human error probability for the failure to recover Division 2 EDG was estimated at 0.202. The performance shaping factors that were determined to be performance drivers were Stress and Experience/Training for Diagnosis, and Stress for Action. Stress was considered to be "high" because the plant would be in a station blackout condition. Experience/Training for Diagnosis was considered to "low." Plant staff perform troubleshooting as a regular job task, however, operators have not trained on, experienced or been exposed to troubleshooting a failure of the "protected" diesel generator during a shutdown SBO.

14. The human error probability for the failure to implement the FLEX electrical line-up was estimated at $2.5E-1$. The performance shaping factors that were determined to be performance drivers were stress for diagnosis and action, and complexity and experience/training for action. Stress was considered to be "high" because the plant would be in a station blackout condition. The action to align the FLEX electrical system was considered to be both "highly" complex and was assigned "low" experience/training. The procedure requires many in-plant actions under difficult conditions and the alignment has never been implemented.
15. The human error probability for the failure to implement the Division 3 to Division 2 crosstie was estimated at $2.7E-1$. The performance shaping factors that were determined to be performance drivers were stress for diagnosis and action, and complexity, experience/training, and ergonomics for action. Stress was considered to be "high" because the plant would be in a station blackout condition. The action to implement the cross-tie was considered to be "highly" complex and was assigned "low" experience/training and "poor" ergonomics. The procedure has both in-plant and control room actions in multiple locations and has received very little training.
16. Offsite power recovery is also modeled but is complicated by electrical system re-alignment when FLEX or the Division 3 cross-tie are attempted but fail. These strategies significantly alter the electrical distribution system. The detailed risk evaluation models offsite power non-recovery at 13 hours or 24 hours, depending on the sequence. The offsite power recovery curve is used along with a human error probability for the failure to realign the electrical system once other sources of power have been attempted but failed. The performance shaping factors that were considered to be performance drivers for the failure to realign the electrical system were stress for diagnosis and action and procedures for action. Stress was considered to be "high" because the plant would be in a station blackout condition. Procedures were considered to be "incomplete" as there are procedures for aligning offsite power sources but they would not specifically address the electrical alignment that would exist after FLEX and the crosstie have been attempted but not successfully implemented. The HEP was estimated at $7.61E-2$.
17. Alignment of alternate suppression pool cooling using FLEX equipment was modeled. The human error probability was estimated at $2.33E-1$. The performance shaping factors that were determined to be performance drivers were stress for diagnosis and action, and complexity, experience/training, and ergonomics for action. Diagnosis was considered to be "obvious" as the need for suppression pool cooling during SBO events is well understood. Stress was considered to be "high" because the plant would be in a station blackout condition. The action was considered to be "moderately" complex, have "low" experience/training, and "poor" ergonomics. The steps to perform the action are performed outside the control room in poor lighting and there is infrequent training and no actual experience. The procedure describes some of the steps as physically demanding and some are in high radiation areas.
18. Two methods of RCS Injection using FLEX equipment were modeled. The easier method would be to re-align the FLEX SPC method for injection. The human error probability for this action was estimated at $4E-3$. The less preferred method, using the diesel-driven FLEX pumps, was estimated at $1.1E-1$. For the easier method, the

performance shaping factors that were determined to be performance drivers were stress for diagnosis and action. The diagnosis was also assumed to be obvious, given that the FLEX suppression pool cooling alignment would already be in place and working successfully. Minimal additional action would be required to re-align the system for injection. The actions to use the less preferred method of direct injection from the lake with the diesel driven pumps was not an important action driving the results of the analysis.

19. Alignment of the ultimate heat sink using FLEX equipment was modeled. The human error probability was estimated at $1.39E-2$. The performance shaping factors that were determined to be performance drivers were stress for diagnosis and action and time, complexity, experience/training, and ergonomics for action. Diagnosis was considered to be "obvious" similar to the rating for aligning suppression pool cooling. Stress was considered to be "high" because the plant would be in station blackout condition. The time available for the action was considered to be greater than 5x the time required. Complexity was considered to be "moderate", experience/training "low", and ergonomics "poor". The steps to perform the action are performed outside the control room in poor lighting and there is infrequent training and no actual experience. The procedure describes some of the steps as physically demanding and some are in high radiation areas.
20. Use of B.5.b equipment and strategies to maintain the reactor depressurized was modeled with an operator action that was highly dependent on the operator action to use FLEX strategies. The FLEX strategy to maintain the reactor depressurized was assumed to be the preferred method. The human error probability for the dependent operator action was $5.2E-1$.
21. Primary containment was open during the exposure time. However, procedures would instruct operators to take action to establish primary containment. The detailed risk evaluation assumes that operators would take this action and would establish primary containment. If suppression pool cooling is not established, then containment venting would be required, consistent with at-power PRA model assumptions. Manual venting of containment was credited. These are long sequences containing success of core cooling via injection but failure to establish suppression pool cooling. These assumptions did not impact the dominant core damage sequences.
22. Alternate injection with fire water system was modeled with equipment failures and an operator action for the failure to align the system. This method was assumed to be the least preferred method of low pressure injection. The operator failure to align fire water injection was assigned an HEP of $1.2E-1$ and was not modeled as dependent on previous operator actions, a possible non-conservative assumption. These assumptions did not impact the dominant core damage sequences.
23. The FLEX diesel generators were assigned a failure to start of $7.2E-2$ and a failure to run for the mission time of $1.5E-1$. The failure to start was based on actual plant operating experience. The run time data for the diesel generators was very limited and could not be used to estimate the failure to run probability. The failure to run for emergency diesel generators was multiplied by a factor of 5 based on analyst judgement to obtain the failure to run rate of the FLEX diesel generator.

24. The FLEX diesel-driven pumps were assigned a failure to start of $1E-2$ and a failure to run of $2.1E-1$. Based on analyst judgment these failure rates we set at five times the corresponding failure rates for permanently installed diesel driven fire pumps.
25. FLEX equipment was assigned a failure probability due to design or construction of $5E-2$. The FLEX strategies, although carefully developed and reviewed for the Mitigating Strategies Order, have never been fully demonstrated. Latent design or construction errors could exist.
26. The Division 3 to the Division 2 cross-tie was assigned a failure probability due to design error of $2E-2$. Both divisions are normally in-service but never cross-tied and the cross-tie has never been fully demonstrated.

Table 2: Summary of Dominant HRA Results

(b)(7)(F)



~~OFFICIAL USE ONLY - SECURITY-RELATED INFORMATION~~

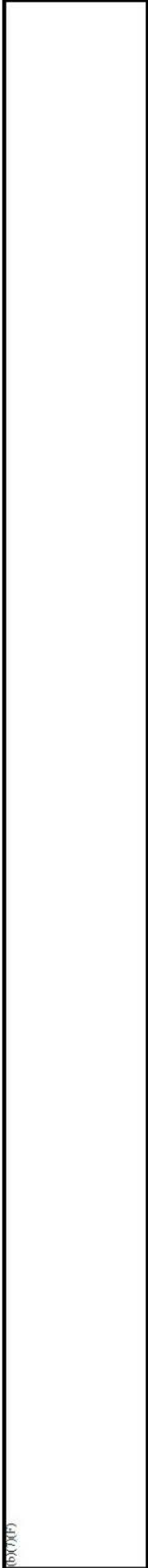

(b)(7)(F)

~~OFFICIAL USE ONLY - SECURITY-RELATED INFORMATION~~

References

1. Clinton SPAR Model, Revision 8.54 with Modifications
2. NUREG-1842, "Good Practices for Implementing Human Reliability Analysis." April 2005
3. NUREG/CR-6595 Revision 1, "An Approach for Estimating the Frequencies of Various Containment Failure Modes and Bypass Events." October 2004
4. NUREG/CR-6883, "The SPAR-H Human Reliability Analysis Method"
5. INL/EXT-10-18533, "SPAR-H Step-by-Step Guidance"
6. RASP Manual Volume 1 – Internal Events, Revision 2.02 date December 2017
7. NUREG/CR-1278, "Handbook of HRA with Emphasis on Nuclear Power Plant Applications," August 1983
8. Analysis of Loss-of Offsite-Power Events 1987-2016, INL/EXT-17-42376 August 2017 (<https://nrcoe.inl.gov/resultsdb/publicdocs/LOSP/loop-summary-update-2016.pdf>)
9. IMC 0609 Appendix G, "Shutdown Operations SDP"
10. NUMARC 91-06, "Guidelines for Industry Actions to Assess Shutdown Management." December 1991
11. CPS 3002.01 R32e Heatup and Pressurization
12. CPS 3312.03 R11d SDC and FPC Assist
13. CPS 3501.01 High Voltage Auxiliary Power System
14. CPS 3506.01 EDG and Support Systems
15. CPS 3506.01P002 Division 2 Diesel Generator Operations
16. CPS 4006.01 Loss of SDC
17. CPS 4200.01 Loss of AC Power
18. CPS 4200.01C002 DC Load Shedding during SBO
19. CPS 4303.01P001 Containment Venting Without AC Power Available
20. CPS 4303.01P004 SRV Operation With External DC Power
21. CPS 4303.01P023 Cross-Connecting Div. 3 DG to Div. 1(2) ECCS Electrical Busses
22. CPS 4306.01P001 FLEX Electrical Connection
23. CPS 4306.01P002 FLEX UHS Water Supply
24. CPS 4306.01P003 FLEX Suppression Pool Cooling
25. CPS 4306.01P004 FLEX Low Pressure RPV Makeup
26. CPS 4306.01P017 ELAP During Modes 4 and 5
27. CPS 5285_R27c Alarm Panel 5285 Annunciators at 1PL12JB
28. CPS 5061.07 Alarm Panel 5061 Annunciators – Row 7
29. CPS 4411.03 Injection Flooding Sources
30. CPS 4411.06 Emergency Containment Venting, Purging and Vacuum Relief
31. CPS 9065.01 Secondary Containment Access Integrity
32. EOP-1 RPV Control
33. EOP-2 RPV Flooding
34. EOP-3 Emergency RPV Depressurization (Blowdown)
35. EOP-6 Primary Containment Control
36. EOP-8 Secondary Containment Control
37. CC-AA-118 Corporate FLEX Process Guidance
38. OU-AA-103 Shutdown Safety Management Program
39. OU-CL-104 Shutdown Safety Management Program (Clinton Power Station)
40. CL-SDP-010 Risk Assessment – May 2018 Outage: Division 2 DG 1B Unavailable with Division 1 Bus Unavailable, Rev. 0
41. DB430301 DBIG-Extensive Damage Mitigation Guide, Rev. 5

- 42. N-CL-OPS-DB430601, FLEX, Rev. 0
- 43. SE-LOP-162, Extensive Damage Mitigation, Rev. 0
- 44. SE-LOR-4306, FLEX Event, Rev. 0

Event Tree and Fault Tree Figures

Figure 2: LOOP Event Tree 1

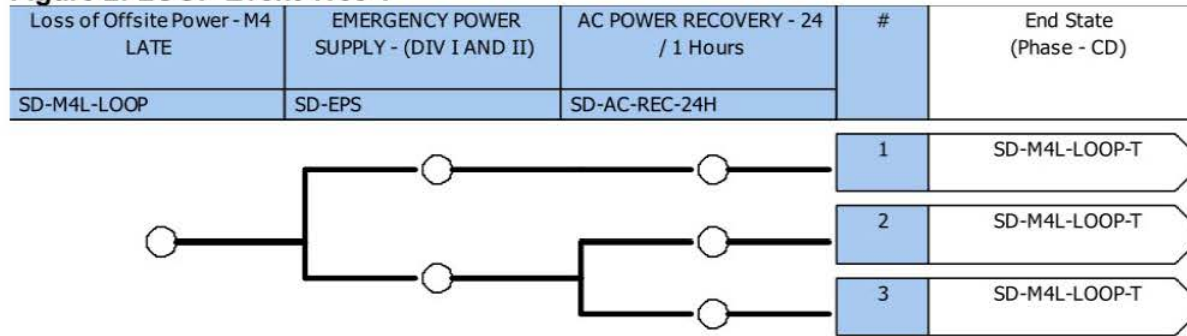

Figure 3: LOOP Event Tree 2

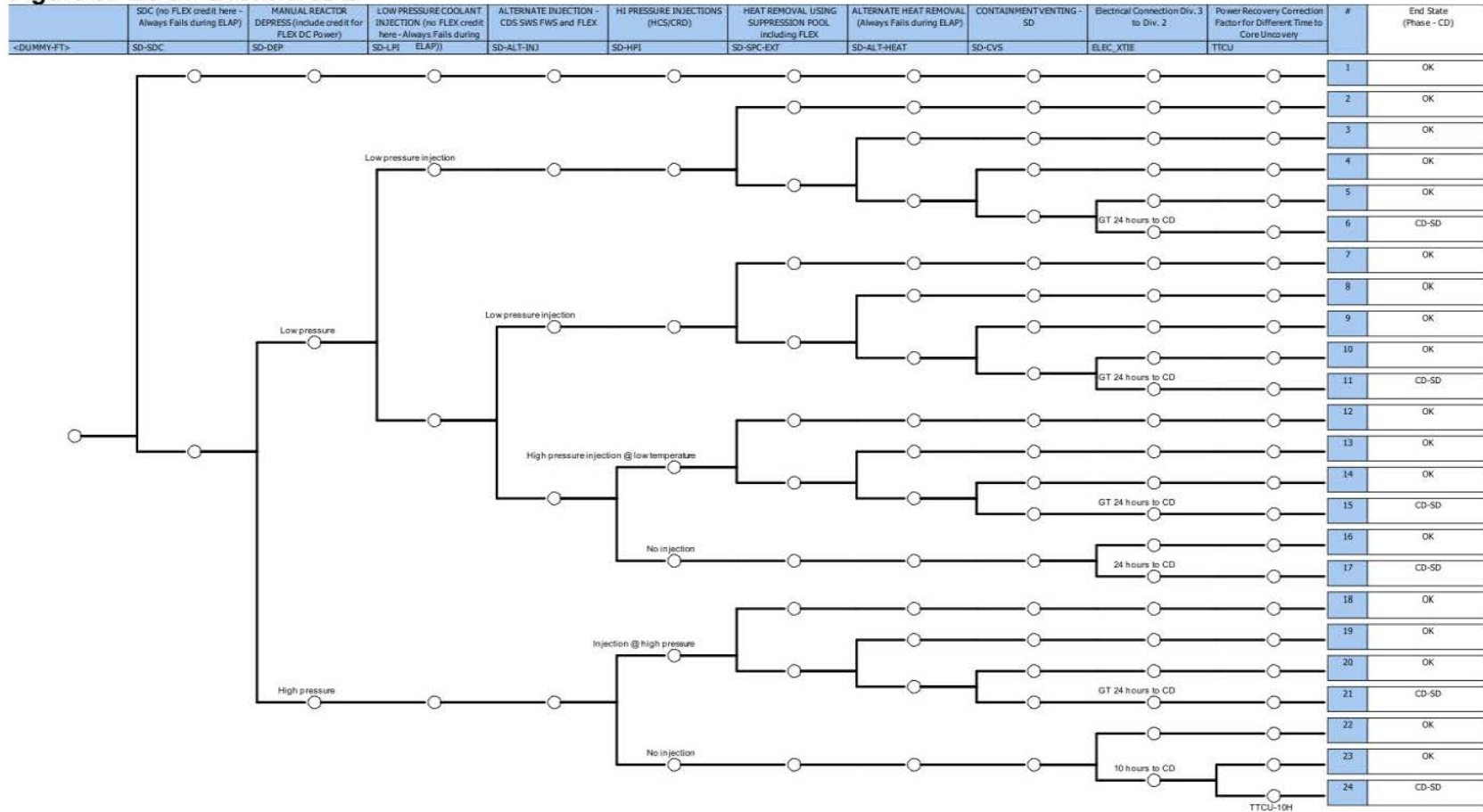

Figure 4: AC Power Recovery Fault Tree

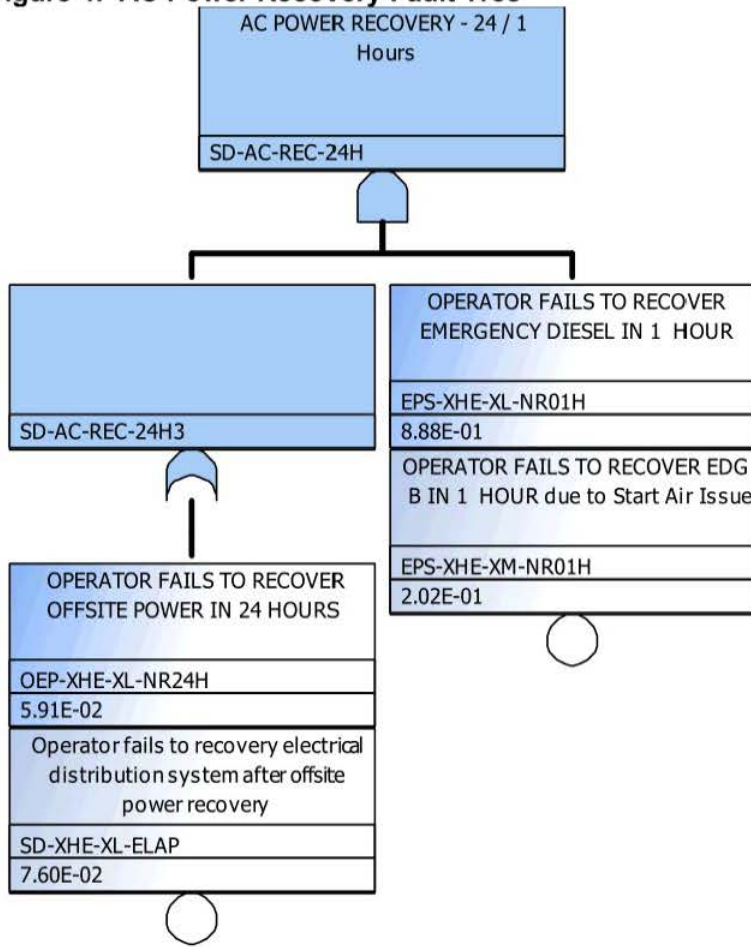

Figure 5: Manual Depressurization Fault Tree

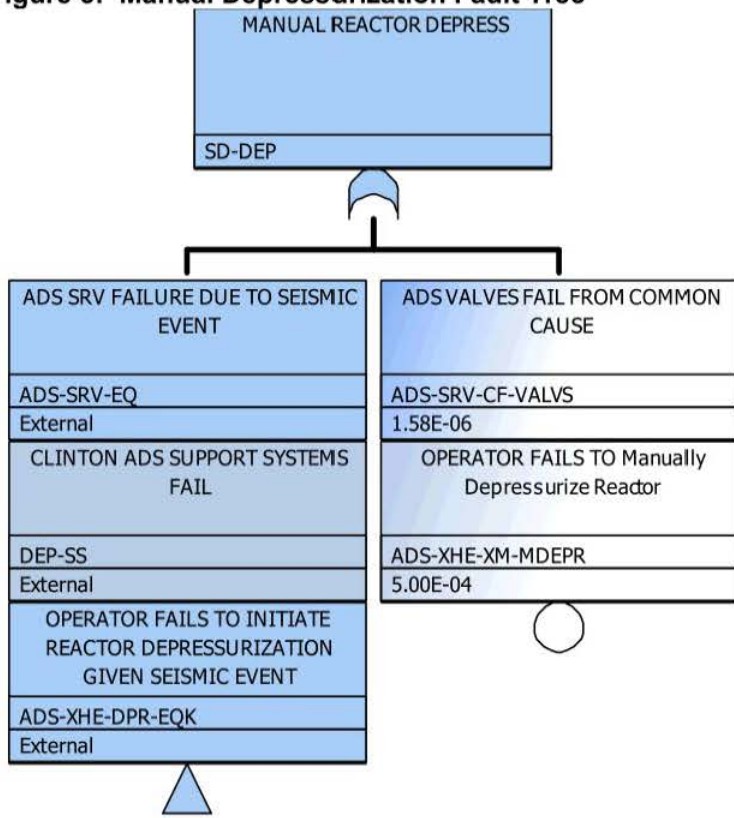

Figure 6: Division I 125 Power Fault Tree (shows FLEX linkage)

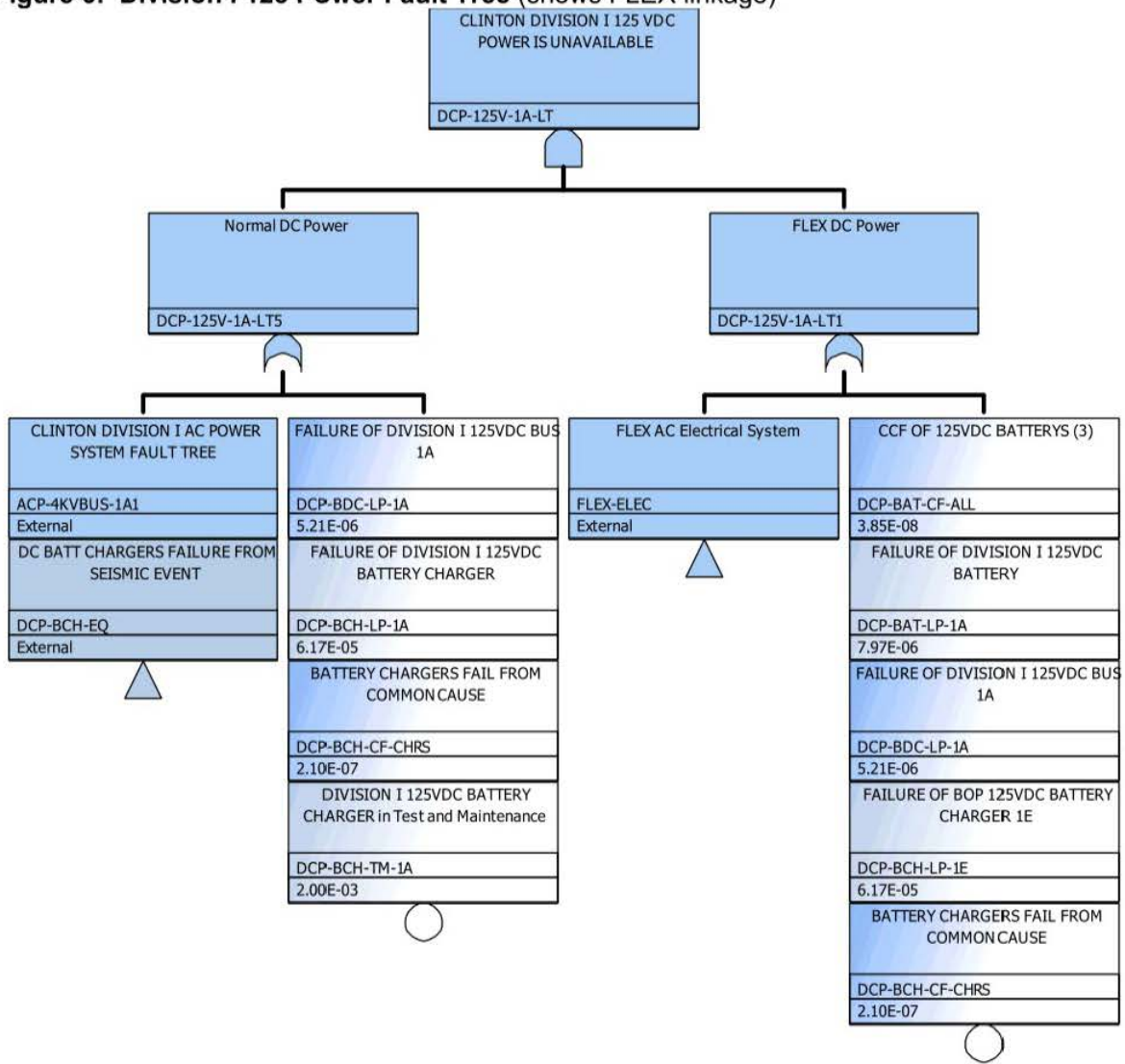

Figure 7: FLEX Electrical Fault Tree

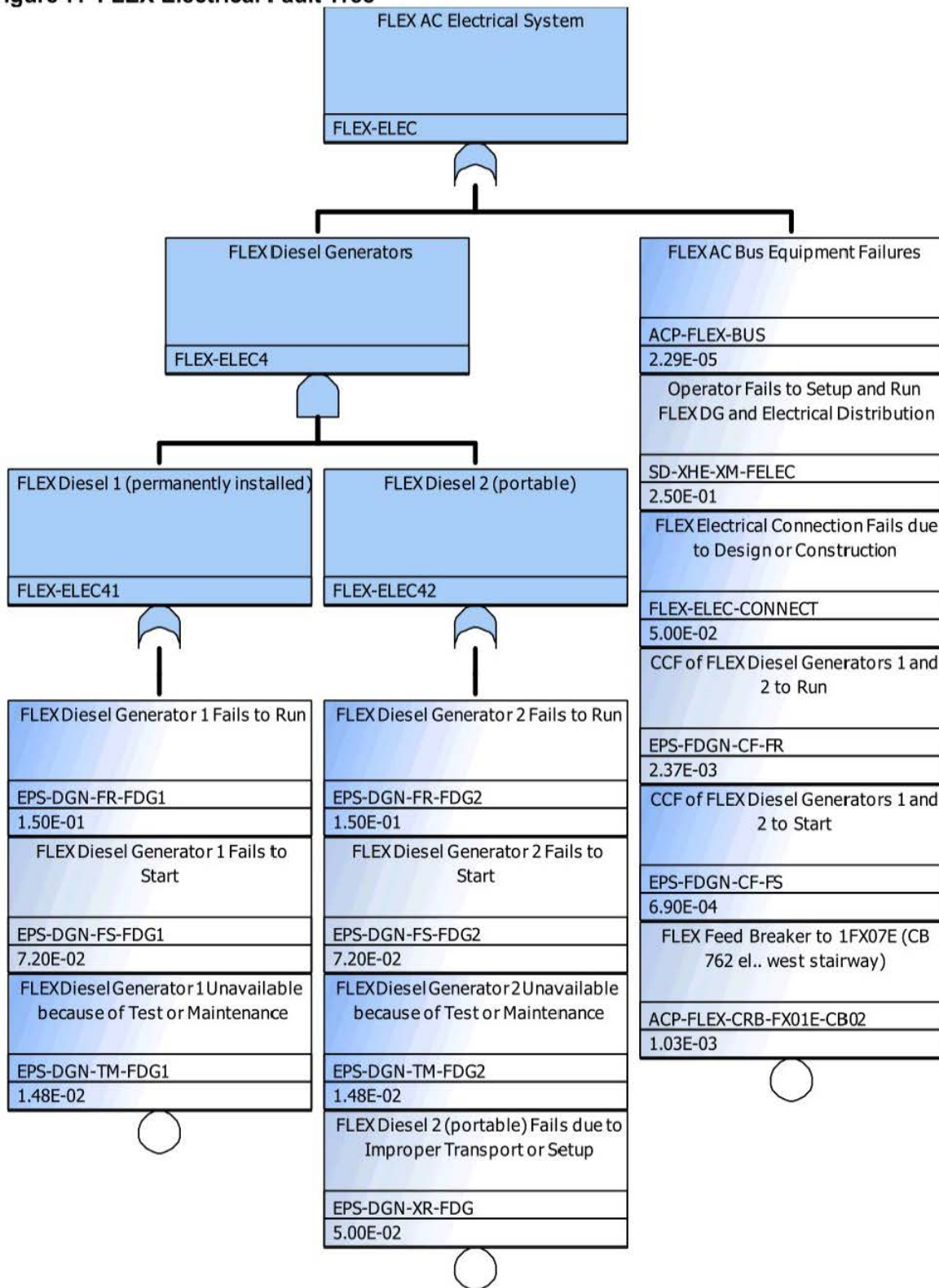

Figure 8: Alternate Injection Fault Tree (includes FLEX)

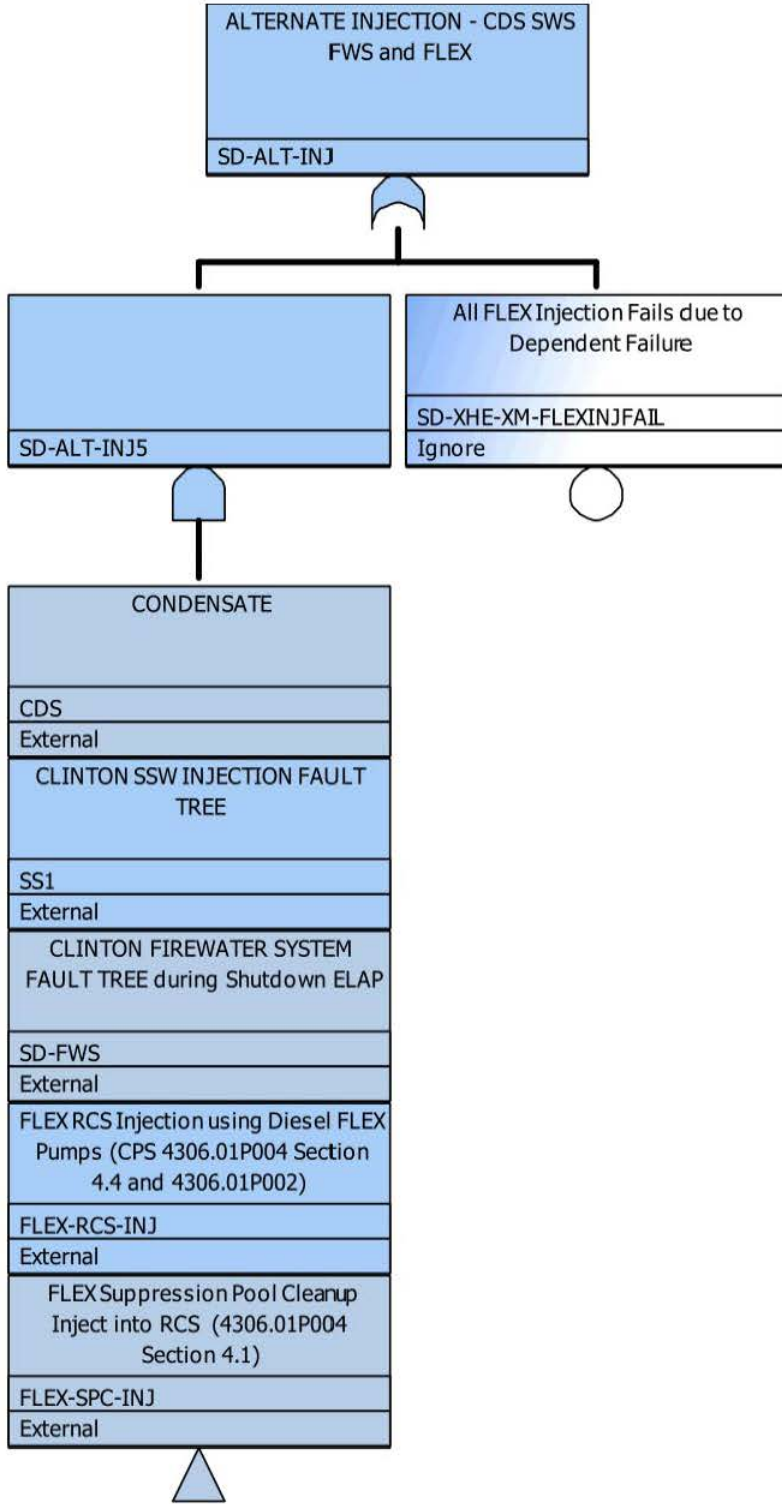

Figure 9: RCS Injection using FLEX Diesel Driven FLEX Pumps Fault Tree

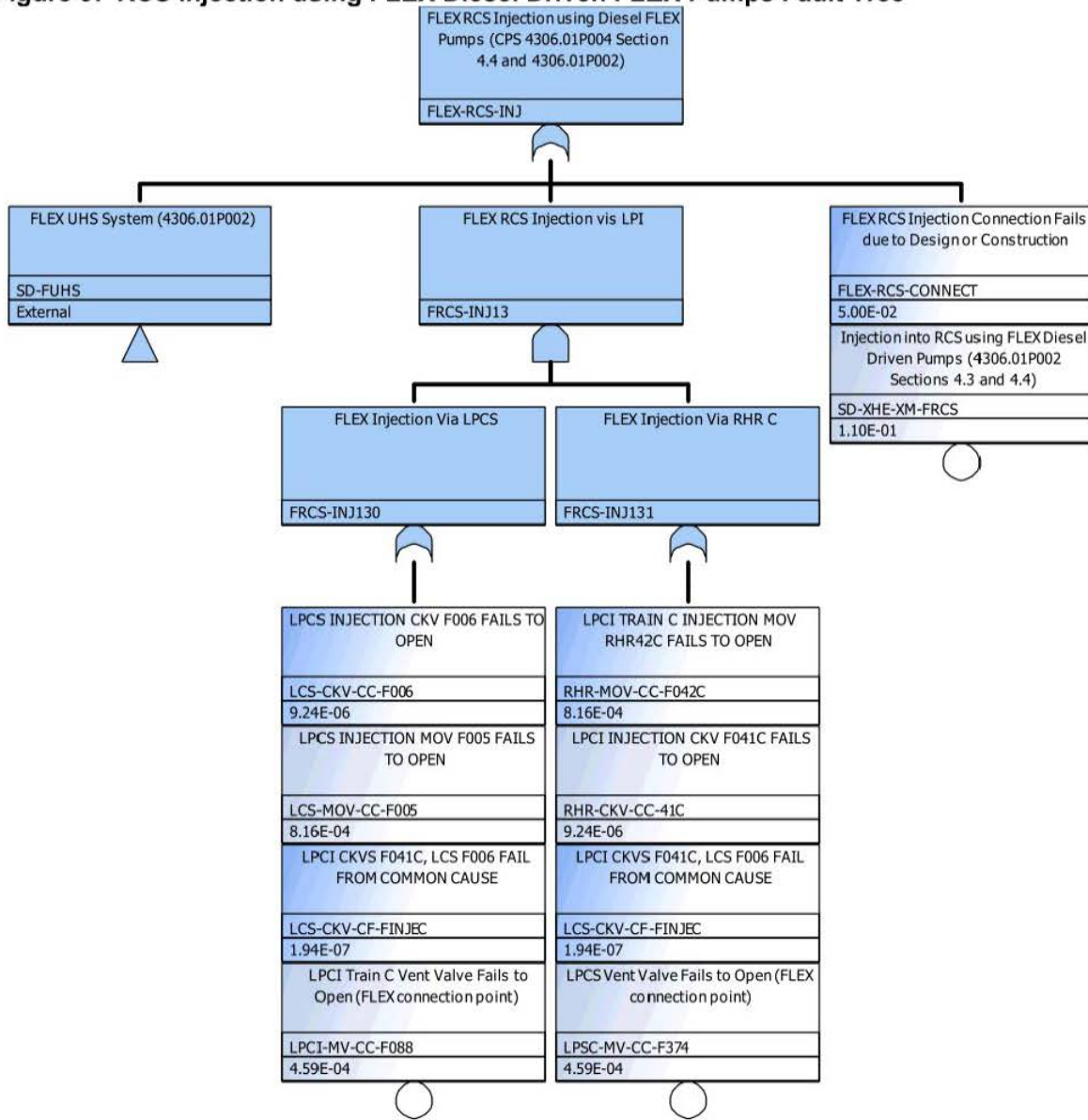

Figure 10: FLEX Ultimate Heat Sink System Fault Tree

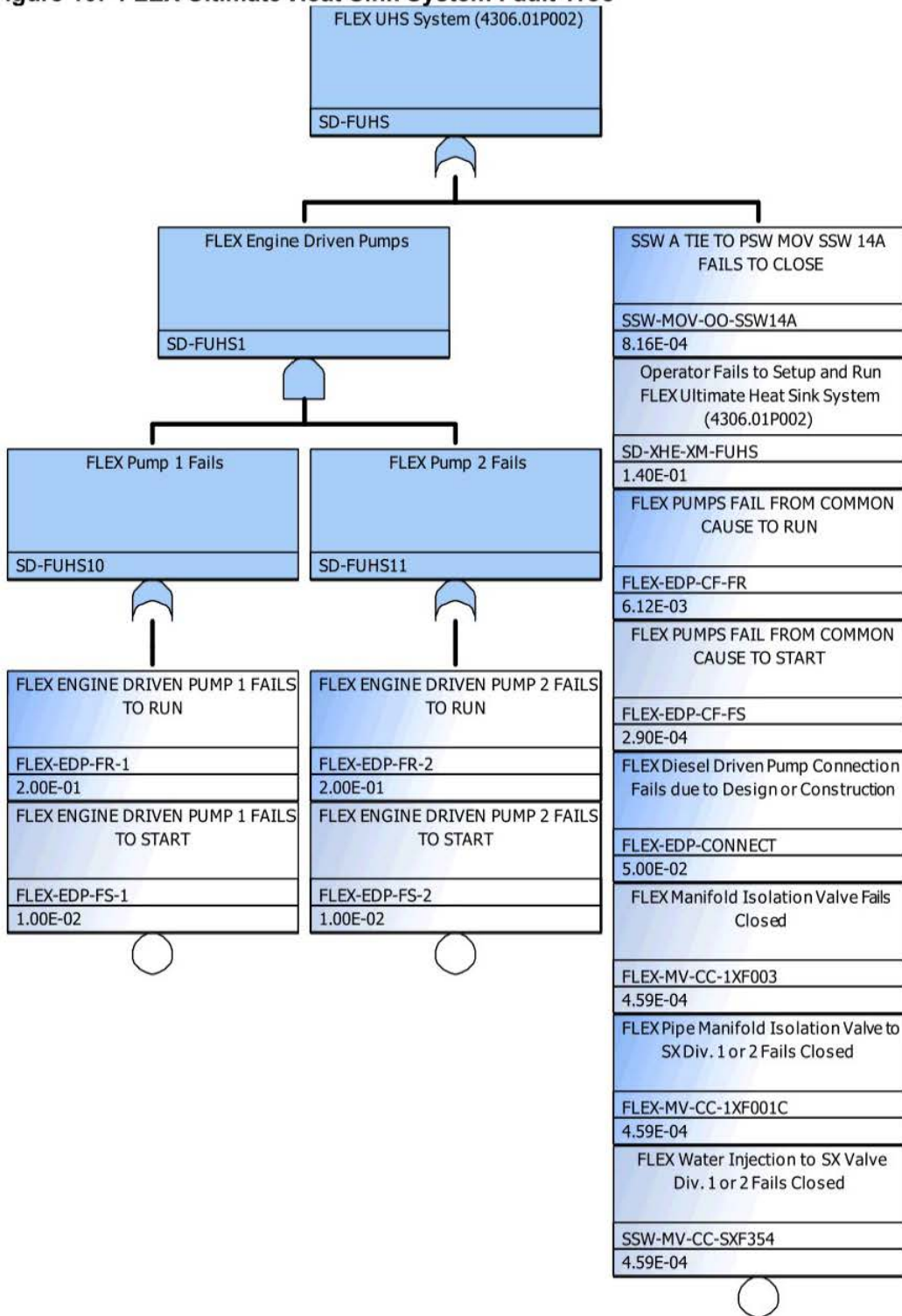

Figure 11: RCS Injection using FLEX Suppression Pool Cleanup Fault Tree

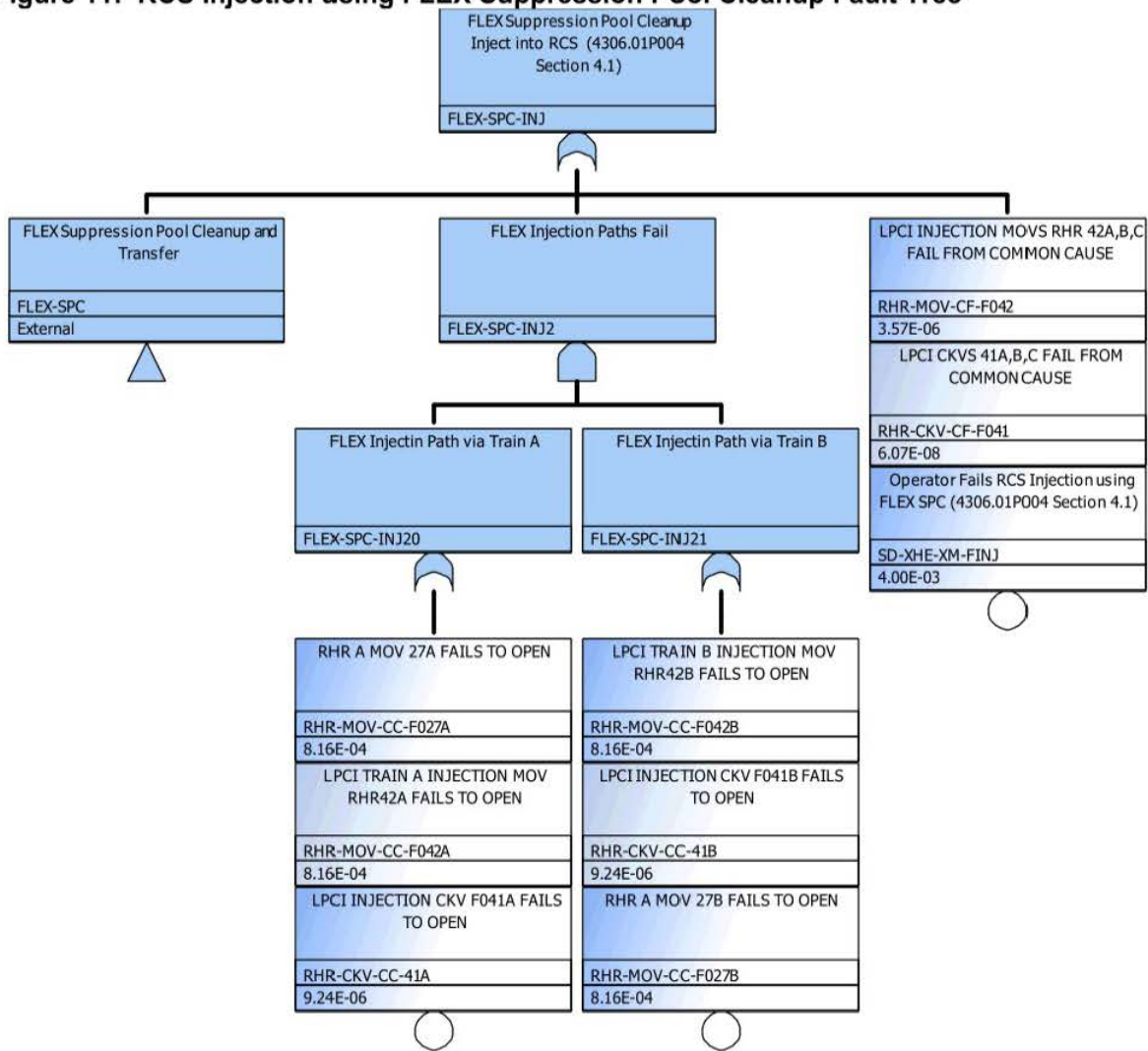

Figure 12: FLEX Suppression Pool Cleanup and Transfer Fault Tree

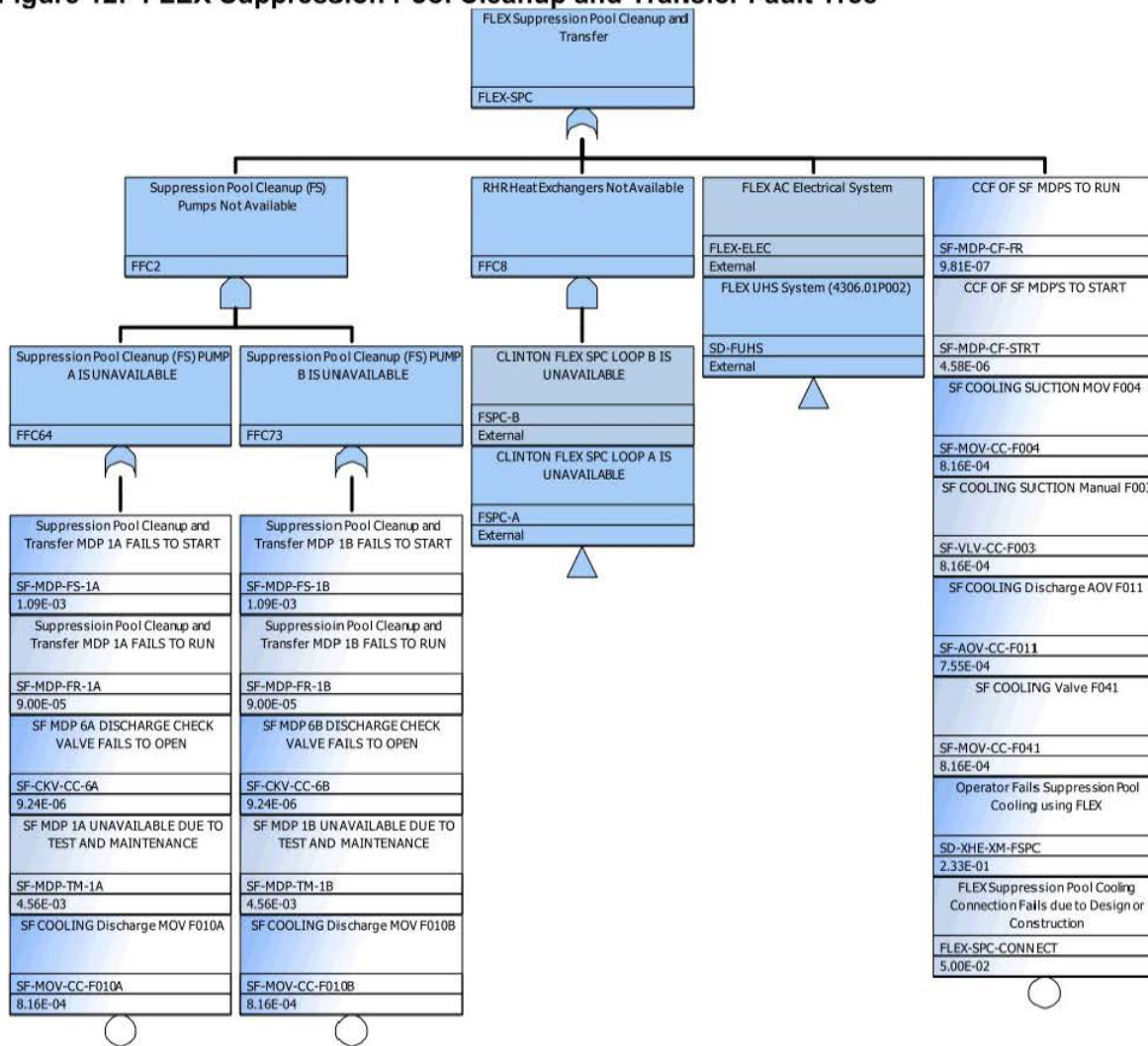

Figure 13: FLEX Suppression Pool Cooling using RHR Heat Exchanger A Fault Tree

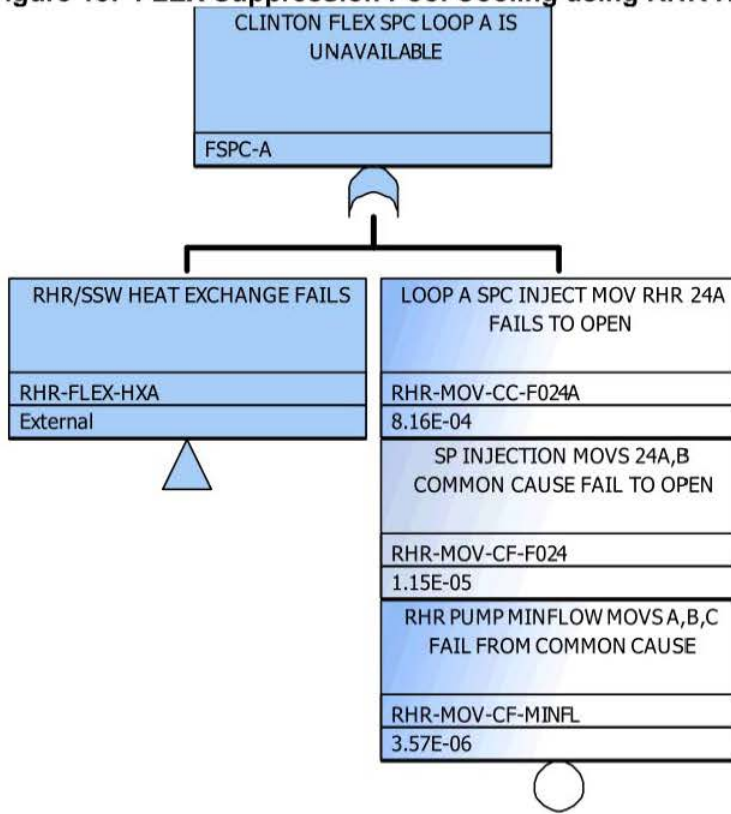

Figure 14: RHR Heat Exchanger A for FLEX SPC Fault Tree

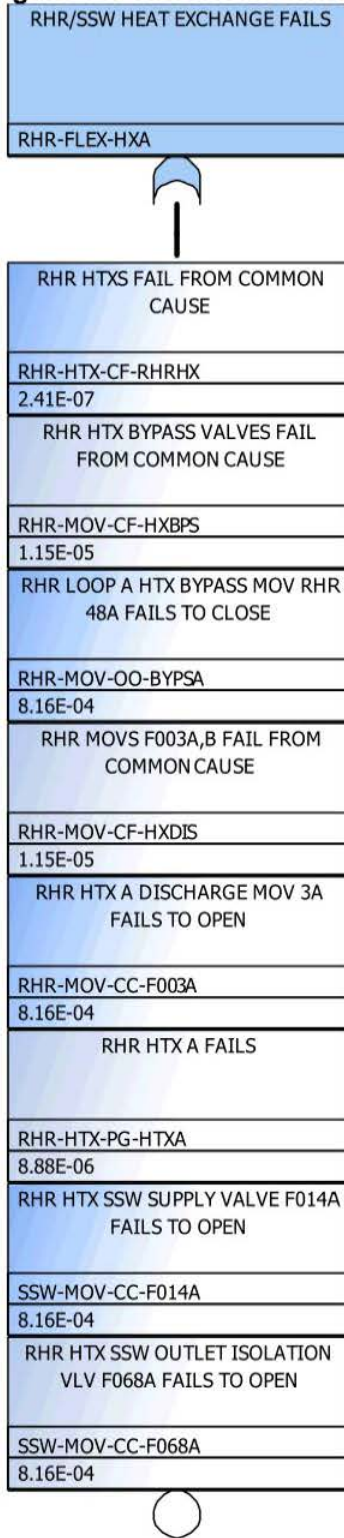

Figure 15: Containment Venting Fault Tree

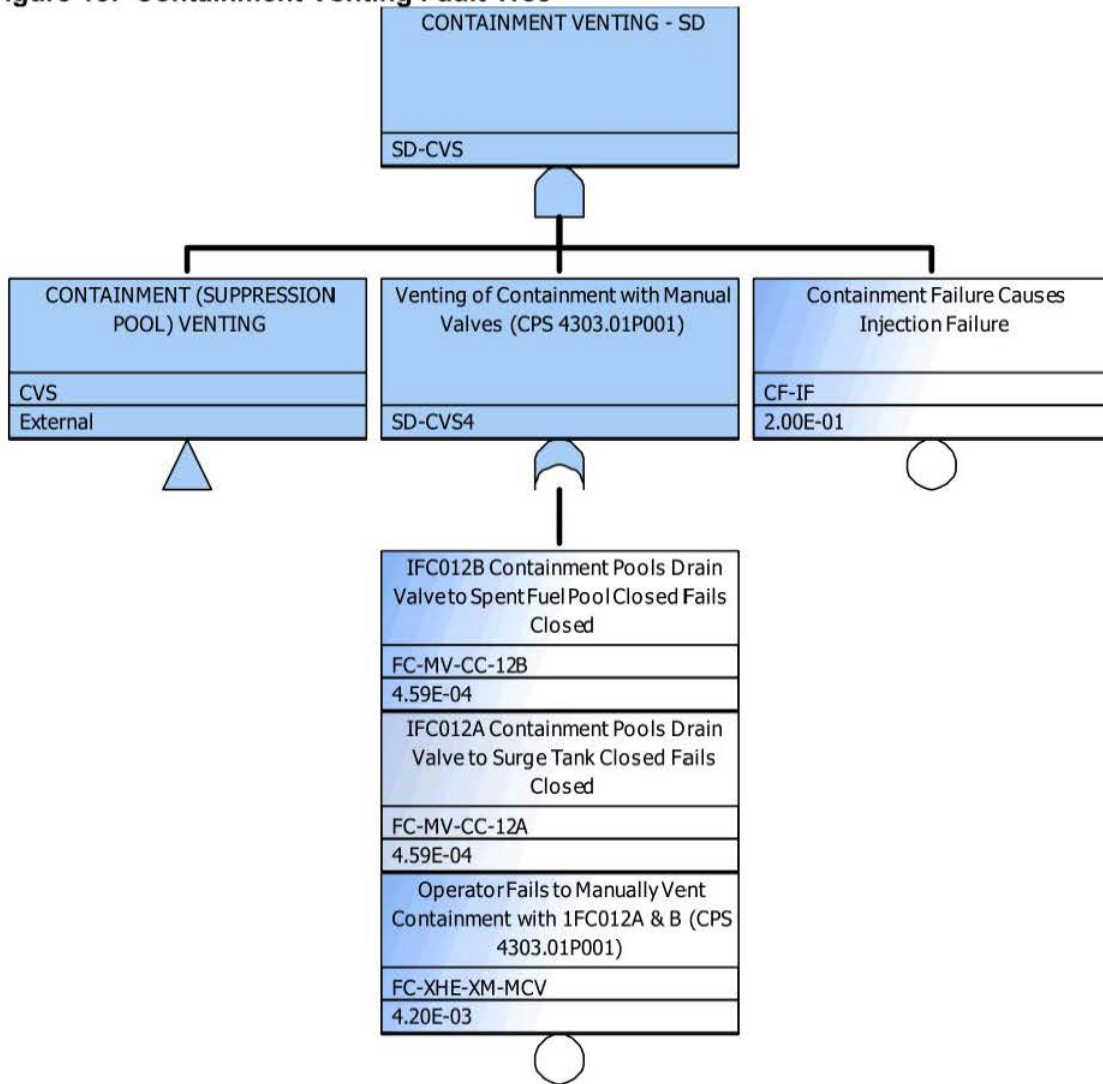

Figure 16: Electrical Cross-Tie Division 3 to Division 2 Fault Tree

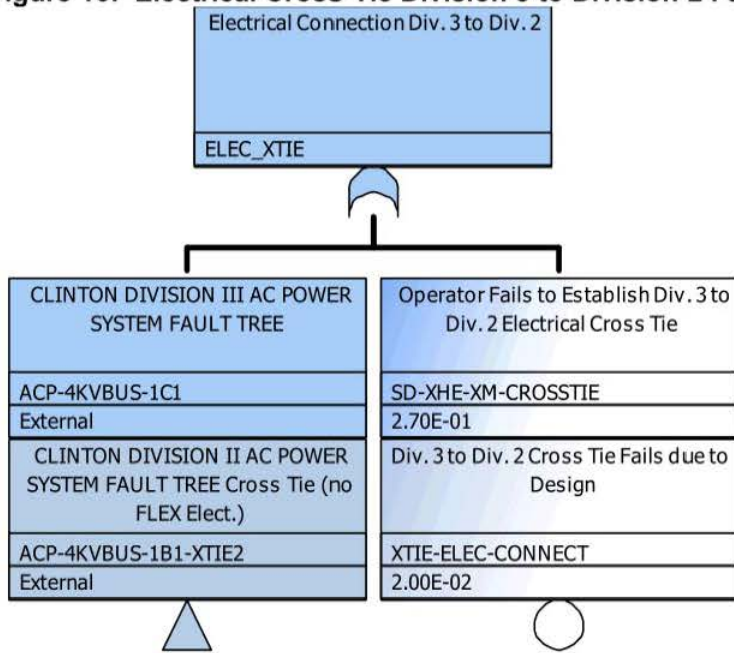
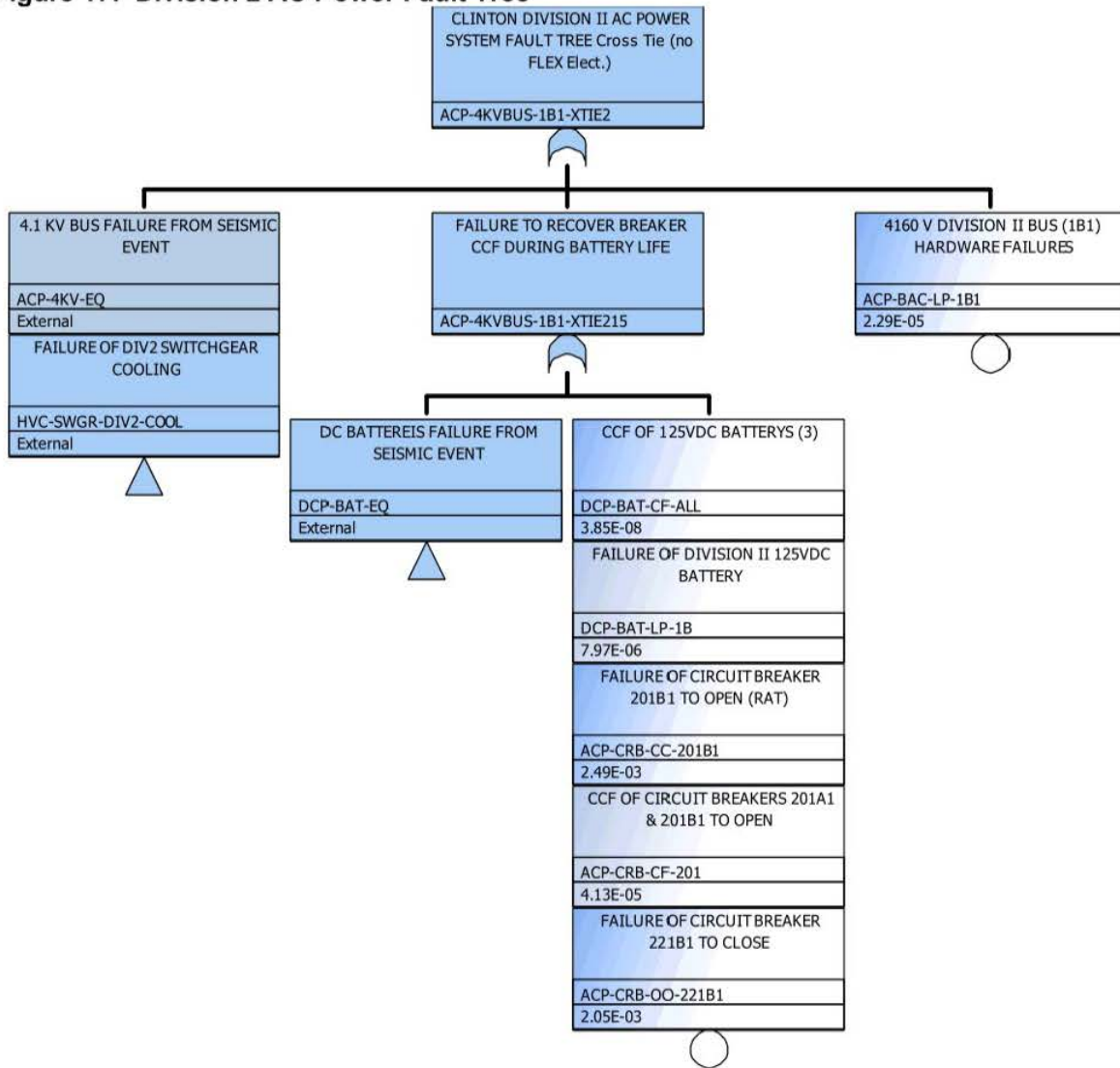

Figure 17: Division 2 AC Power Fault Tree



~~OFFICIAL USE ONLY – SECURITY-RELATED INFORMATION~~

Cut Set Report - 0-SD-			CLINTON SPAR MODEL		
#	Case	Prob/Freq	Total %	Cut Set	Description
Total		4.86E-04	100	Displaying 30 Cut Sets. (27055 Original)	
1	C	1.60E-04	32.98	0-SD-M4L-LOOP : 3-24	
		1.68E-01		SD-M4L-LOOP	Loss of Offsite Power - M4 LATE
		2.02E-01		EPS-XHE-XM-NR01H	OPERATOR FAILS TO RECOVER EDG B IN 1 HOUR due to Start Air Issue
		1.37E-01		OEP-XHE-XL-NR10H	OPERATOR FAILS TO RECOVER OFFSITE POWER IN 10 HOURS
		2.70E-01		SD-XHE-XM-CROSSTIE	Operator Fails to Establish Div. 3 to Div. 2 Electrical Cross Tie
		5.11E-01		SD-XHE-XM-DEPB5B	Operator Fails to setup B5b Equipment for Depressurization (dependent)
		2.50E-01		SD-XHE-XM-FELEC	Operator Fails to Setup and Run FLEX DG and Electrical Distribution
		1.00E+00		TTCU-10	Time to Core Uncovery 10 hours or greater
2	C	8.90E-05	18.32	0-SD-M4L-LOOP : 3-24	
		1.68E-01		SD-M4L-LOOP	Loss of Offsite Power - M4 LATE
		2.02E-01		EPS-XHE-XM-NR01H	OPERATOR FAILS TO RECOVER EDG B IN 1 HOUR due to Start Air Issue
		7.60E-02		SD-XHE-XL-ELAP	Operator fails to recovery electrical distribution system after offsite power recovery
		2.70E-01		SD-XHE-XM-CROSSTIE	Operator Fails to Establish Div. 3 to Div. 2 Electrical Cross Tie
		5.11E-01		SD-XHE-XM-DEPB5B	Operator Fails to setup B5b Equipment for Depressurization (dependent)
		2.50E-01		SD-XHE-XM-FELEC	Operator Fails to Setup and Run FLEX DG and Electrical Distribution
3	C	3.20E-05	6.6	0-SD-M4L-LOOP : 3-24	
		1.68E-01		SD-M4L-LOOP	Loss of Offsite Power - M4 LATE
		2.02E-01		EPS-XHE-XM-NR01H	OPERATOR FAILS TO RECOVER EDG B IN 1 HOUR due to Start Air Issue
		5.00E-02		FLEX-ELEC-CONNECT	FLEX Electrical Connection Fails due to Design or Construction
		1.37E-01		OEP-XHE-XL-NR10H	OPERATOR FAILS TO RECOVER OFFSITE POWER IN 10 HOURS
		2.70E-01		SD-XHE-XM-CROSSTIE	Operator Fails to Establish Div. 3 to Div. 2 Electrical Cross Tie
		5.11E-01		SD-XHE-XM-DEPB5B	Operator Fails to setup B5b Equipment for Depressurization (dependent)
		1.00E+00		TTCU-10	Time to Core Uncovery 10 hours or greater
4	C	3.13E-05	6.45	0-SD-M4L-LOOP : 3-24	
		1.68E-01		SD-M4L-LOOP	Loss of Offsite Power - M4 LATE
		1.00E-01		DEP-B5B	B5b Equipment for Opening SRVs
		2.02E-01		EPS-XHE-XM-NR01H	OPERATOR FAILS TO RECOVER EDG B IN 1 HOUR due to Start Air Issue
		1.37E-01		OEP-XHE-XL-NR10H	OPERATOR FAILS TO RECOVER OFFSITE POWER IN 10 HOURS
		2.70E-01		SD-XHE-XM-CROSSTIE	Operator Fails to Establish Div. 3 to Div. 2 Electrical Cross Tie
		2.50E-01		SD-XHE-XM-FELEC	Operator Fails to Setup and Run FLEX DG and Electrical Distribution
		1.00E+00		TTCU-10	Time to Core Uncovery 10 hours or greater
5	C	2.01E-05	4.14	0-SD-M4L-LOOP : 3-24	
		1.68E-01		SD-M4L-LOOP	Loss of Offsite Power - M4 LATE
		3.39E-02		EPS-DGN-FR-DG1C	DIESEL GENERATOR 1C FAILS TO RUN
		2.02E-01		EPS-XHE-XM-NR01H	OPERATOR FAILS TO RECOVER EDG B IN 1 HOUR due to Start Air Issue
		1.37E-01		OEP-XHE-XL-NR10H	OPERATOR FAILS TO RECOVER OFFSITE POWER IN 10 HOURS
		9.99E-01		OEP-XHE-XX-NR24H1	Convolution Factor for 1FTR-OPR (24H)

~~OFFICIAL USE ONLY – SECURITY-RELATED INFORMATION~~

~~OFFICIAL USE ONLY – SECURITY-RELATED INFORMATION~~

		5.11E-01		SD-XHE-XM-DEPB5B	Operator Fails to setup B5b Equipment for Depressurization (dependent)
		2.50E-01		SD-XHE-XM-FELEC	Operator Fails to Setup and Run FLEX DG and Electrical Distribution
		1.00E+00		TTCU-10	Time to Core Uncovery 10 hours or greater
6	C	1.78E-05	3.66	0-SD-M4L-LOOP : 3-24	
		1.68E-01		SD-M4L-LOOP	Loss of Offsite Power - M4 LATE
		2.02E-01		EPS-XHE-XM-NR01H	OPERATOR FAILS TO RECOVER EDG B IN 1 HOUR due to Start Air Issue
		5.00E-02		FLEX-ELEC-CONNECT	FLEX Electrical Connection Fails due to Design or Construction
		7.60E-02		SD-XHE-XL-ELAP	Operator fails to recovery electrical distribution system after offsite power recovery
		2.70E-01		SD-XHE-XM-CROSSTIE	Operator Fails to Establish Div. 3 to Div. 2 Electrical Cross Tie
		5.11E-01		SD-XHE-XM-DEPB5B	Operator Fails to setup B5b Equipment for Depressurization (dependent)
7	C	1.74E-05	3.58	0-SD-M4L-LOOP : 3-24	
		1.68E-01		SD-M4L-LOOP	Loss of Offsite Power - M4 LATE
		1.00E-01		DEP-B5B	B5b Equipment for Opening SRVs
		2.02E-01		EPS-XHE-XM-NR01H	OPERATOR FAILS TO RECOVER EDG B IN 1 HOUR due to Start Air Issue
		7.60E-02		SD-XHE-XL-ELAP	Operator fails to recovery electrical distribution system after offsite power recovery
		2.70E-01		SD-XHE-XM-CROSSTIE	Operator Fails to Establish Div. 3 to Div. 2 Electrical Cross Tie
		2.50E-01		SD-XHE-XM-FELEC	Operator Fails to Setup and Run FLEX DG and Electrical Distribution
8	C	1.44E-05	2.97	0-SD-M4L-LOOP : 3-24	
		1.68E-01		SD-M4L-LOOP	Loss of Offsite Power - M4 LATE
		1.50E-01		EPS-DGN-FR-FDG1	FLEX Diesel Generator 1 Fails to Run
		1.50E-01		EPS-DGN-FR-FDG2	FLEX Diesel Generator 2 Fails to Run
		2.02E-01		EPS-XHE-XM-NR01H	OPERATOR FAILS TO RECOVER EDG B IN 1 HOUR due to Start Air Issue
		1.37E-01		OEP-XHE-XL-NR10H	OPERATOR FAILS TO RECOVER OFFSITE POWER IN 10 HOURS
		2.70E-01		SD-XHE-XM-CROSSTIE	Operator Fails to Establish Div. 3 to Div. 2 Electrical Cross Tie
		5.11E-01		SD-XHE-XM-DEPB5B	Operator Fails to setup B5b Equipment for Depressurization (dependent)
		1.00E+00		TTCU-10	Time to Core Uncovery 10 hours or greater
9	C	1.19E-05	2.44	0-SD-M4L-LOOP : 3-24	
		1.68E-01		SD-M4L-LOOP	Loss of Offsite Power - M4 LATE
		2.02E-01		EPS-XHE-XM-NR01H	OPERATOR FAILS TO RECOVER EDG B IN 1 HOUR due to Start Air Issue
		1.37E-01		OEP-XHE-XL-NR10H	OPERATOR FAILS TO RECOVER OFFSITE POWER IN 10 HOURS
		5.11E-01		SD-XHE-XM-DEPB5B	Operator Fails to setup B5b Equipment for Depressurization (dependent)
		2.50E-01		SD-XHE-XM-FELEC	Operator Fails to Setup and Run FLEX DG and Electrical Distribution
		1.00E+00		TTCU-10	Time to Core Uncovery 10 hours or greater
		2.00E-02		XTIE-ELEC-CONNECT	Div. 3 to Div. 2 Cross Tie Fails due to Design
10	C	1.12E-05	2.3	0-SD-M4L-LOOP : 3-24	
		1.68E-01		SD-M4L-LOOP	Loss of Offsite Power - M4 LATE
		3.39E-02		EPS-DGN-FR-DG1C	DIESEL GENERATOR 1C FAILS TO RUN
		2.02E-01		EPS-XHE-XM-NR01H	OPERATOR FAILS TO RECOVER EDG B IN 1 HOUR due to Start Air Issue
		7.60E-02		SD-XHE-XL-ELAP	Operator fails to recovery electrical distribution system after offsite power recovery
		5.11E-01		SD-XHE-XM-DEPB5B	Operator Fails to setup B5b Equipment for Depressurization (dependent)
		2.50E-01		SD-XHE-XM-FELEC	Operator Fails to Setup and Run FLEX DG and Electrical Distribution

~~OFFICIAL USE ONLY – SECURITY-RELATED INFORMATION~~

~~OFFICIAL USE ONLY – SECURITY-RELATED INFORMATION~~

11	C	8.01E-06	1.65	0-SD-M4L-LOOP : 3-24	
		1.68E-01		SD-M4L-LOOP	Loss of Offsite Power - M4 LATE
		1.50E-01		EPS-DGN-FR-FDG1	FLEX Diesel Generator 1 Fails to Run
		1.50E-01		EPS-DGN-FR-FDG2	FLEX Diesel Generator 2 Fails to Run
		2.02E-01		EPS-XHE-XM-NR01H	OPERATOR FAILS TO RECOVER EDG B IN 1 HOUR due to Start Air Issue
		7.60E-02		SD-XHE-XL-ELAP	Operator fails to recovery electrical distribution system after offsite power recovery
		2.70E-01		SD-XHE-XM-CROSSTIE	Operator Fails to Establish Div. 3 to Div. 2 Electrical Cross Tie
		5.11E-01		SD-XHE-XM-DEPB5B	Operator Fails to setup B5b Equipment for Depressurization (dependent)
		6.92E-06		0-SD-M4L-LOOP : 3-24	
		12		C	1.68E-01
1.50E-01	EPS-DGN-FR-FDG1		FLEX Diesel Generator 1 Fails to Run		
7.20E-02	EPS-DGN-FS-FDG2		FLEX Diesel Generator 2 Fails to Start		
2.02E-01	EPS-XHE-XM-NR01H		OPERATOR FAILS TO RECOVER EDG B IN 1 HOUR due to Start Air Issue		
1.37E-01	OEP-XHE-XL-NR10H		OPERATOR FAILS TO RECOVER OFFSITE POWER IN 10 HOURS		
2.70E-01	SD-XHE-XM-CROSSTIE		Operator Fails to Establish Div. 3 to Div. 2 Electrical Cross Tie		
5.11E-01	SD-XHE-XM-DEPB5B		Operator Fails to setup B5b Equipment for Depressurization (dependent)		
1.00E+00	TTCU-10		Time to Core Uncovery 10 hours or greater		
6.92E-06	0-SD-M4L-LOOP : 3-24				
13	C		1.68E-01		1.42
		1.50E-01	EPS-DGN-FR-FDG2	FLEX Diesel Generator 2 Fails to Run	
		7.20E-02	EPS-DGN-FS-FDG1	FLEX Diesel Generator 1 Fails to Start	
		2.02E-01	EPS-XHE-XM-NR01H	OPERATOR FAILS TO RECOVER EDG B IN 1 HOUR due to Start Air Issue	
		1.37E-01	OEP-XHE-XL-NR10H	OPERATOR FAILS TO RECOVER OFFSITE POWER IN 10 HOURS	
		2.70E-01	SD-XHE-XM-CROSSTIE	Operator Fails to Establish Div. 3 to Div. 2 Electrical Cross Tie	
		5.11E-01	SD-XHE-XM-DEPB5B	Operator Fails to setup B5b Equipment for Depressurization (dependent)	
		1.00E+00	TTCU-10	Time to Core Uncovery 10 hours or greater	
		6.59E-06	0-SD-M4L-LOOP : 3-24		
		14	C	1.68E-01	
2.02E-01	EPS-XHE-XM-NR01H			OPERATOR FAILS TO RECOVER EDG B IN 1 HOUR due to Start Air Issue	
7.60E-02	SD-XHE-XL-ELAP			Operator fails to recovery electrical distribution system after offsite power recovery	
5.11E-01	SD-XHE-XM-DEPB5B			Operator Fails to setup B5b Equipment for Depressurization (dependent)	
2.50E-01	SD-XHE-XM-FELEC			Operator Fails to Setup and Run FLEX DG and Electrical Distribution	
2.00E-02	XTIE-ELEC-CONNECT			Div. 3 to Div. 2 Cross Tie Fails due to Design	
6.27E-06	0-SD-M4L-LOOP : 3-24				
1.68E-01	SD-M4L-LOOP			Loss of Offsite Power - M4 LATE	
1.00E-01	DEP-B5B			B5b Equipment for Opening SRVs	
2.02E-01	EPS-XHE-XM-NR01H			OPERATOR FAILS TO RECOVER EDG B IN 1 HOUR due to Start Air Issue	
15	C	5.00E-02	1.29	FLEX-ELEC-CONNECT	FLEX Electrical Connection Fails due to Design or Construction
		1.37E-01		OEP-XHE-XL-NR10H	OPERATOR FAILS TO RECOVER OFFSITE POWER IN 10 HOURS
		2.70E-01		SD-XHE-XM-CROSSTIE	Operator Fails to Establish Div. 3 to Div. 2 Electrical Cross Tie
		1.00E+00		TTCU-10	Time to Core Uncovery 10 hours or greater

~~OFFICIAL USE ONLY – SECURITY-RELATED INFORMATION~~

~~OFFICIAL USE ONLY – SECURITY-RELATED INFORMATION~~

16	C	4.80E-06	0.99	0-SD-M4L-LOOP : 3-24	
		1.68E-01		SD-M4L-LOOP	Loss of Offsite Power - M4 LATE
		1.50E-01		EPS-DGN-FR-FDG1	FLEX Diesel Generator 1 Fails to Run
		5.00E-02		EPS-DGN-XR-FDG	FLEX Diesel 2 (portable) Fails due to Improper Transport or Setup
		2.02E-01		EPS-XHE-XM-NR01H	OPERATOR FAILS TO RECOVER EDG B IN 1 HOUR due to Start Air Issue
		1.37E-01		OEP-XHE-XL-NR10H	OPERATOR FAILS TO RECOVER OFFSITE POWER IN 10 HOURS
		2.70E-01		SD-XHE-XM-CROSSSTIE	Operator Fails to Establish Div. 3 to Div. 2 Electrical Cross Tie
		5.11E-01		SD-XHE-XM-DEPB5B	Operator Fails to setup B5b Equipment for Depressurization (dependent)
		1.00E+00		TTCU-10	Time to Core Uncovery 10 hours or greater
17	C	4.02E-06	0.83	0-SD-M4L-LOOP : 3-24	
		1.68E-01		SD-M4L-LOOP	Loss of Offsite Power - M4 LATE
		3.39E-02		EPS-DGN-FR-DG1C	DIESEL GENERATOR 1C FAILS TO RUN
		2.02E-01		EPS-XHE-XM-NR01H	OPERATOR FAILS TO RECOVER EDG B IN 1 HOUR due to Start Air Issue
		5.00E-02		FLEX-ELEC-CONNECT	FLEX Electrical Connection Fails due to Design or Construction
		1.37E-01		OEP-XHE-XL-NR10H	OPERATOR FAILS TO RECOVER OFFSITE POWER IN 10 HOURS
		9.99E-01		OEP-XHE-XX-NR24H1	Convolution Factor for 1FTR-OPR (24H-)
		5.11E-01		SD-XHE-XM-DEPB5B	Operator Fails to setup B5b Equipment for Depressurization (dependent)
		1.00E+00		TTCU-10	Time to Core Uncovery 10 hours or greater
18	C	3.93E-06	0.81	0-SD-M4L-LOOP : 3-24	
		1.68E-01		SD-M4L-LOOP	Loss of Offsite Power - M4 LATE
		1.00E-01		DEP-B5B	B5b Equipment for Opening SRVs
		3.39E-02		EPS-DGN-FR-DG1C	DIESEL GENERATOR 1C FAILS TO RUN
		2.02E-01		EPS-XHE-XM-NR01H	OPERATOR FAILS TO RECOVER EDG B IN 1 HOUR due to Start Air Issue
		1.37E-01		OEP-XHE-XL-NR10H	OPERATOR FAILS TO RECOVER OFFSITE POWER IN 10 HOURS
		9.99E-01		OEP-XHE-XX-NR24H1	Convolution Factor for 1FTR-OPR (24H-)
		2.50E-01		SD-XHE-XM-FELEC	Operator Fails to Setup and Run FLEX DG and Electrical Distribution
		1.00E+00		TTCU-10	Time to Core Uncovery 10 hours or greater
19	C	3.84E-06	0.79	0-SD-M4L-LOOP : 3-24	
		1.68E-01		SD-M4L-LOOP	Loss of Offsite Power - M4 LATE
		1.50E-01		EPS-DGN-FR-FDG2	FLEX Diesel Generator 2 Fails to Run
		7.20E-02		EPS-DGN-FS-FDG1	FLEX Diesel Generator 1 Fails to Start
		2.02E-01		EPS-XHE-XM-NR01H	OPERATOR FAILS TO RECOVER EDG B IN 1 HOUR due to Start Air Issue
		7.60E-02		SD-XHE-XL-ELAP	Operator fails to recovery electrical distribution system after offsite power recovery
		2.70E-01		SD-XHE-XM-CROSSSTIE	Operator Fails to Establish Div. 3 to Div. 2 Electrical Cross Tie
		5.11E-01		SD-XHE-XM-DEPB5B	Operator Fails to setup B5b Equipment for Depressurization (dependent)
		1.00E+00		TTCU-10	Time to Core Uncovery 10 hours or greater
20	C	3.84E-06	0.79	0-SD-M4L-LOOP : 3-24	
		1.68E-01		SD-M4L-LOOP	Loss of Offsite Power - M4 LATE
		1.50E-01		EPS-DGN-FR-FDG1	FLEX Diesel Generator 1 Fails to Run
		7.20E-02		EPS-DGN-FS-FDG2	FLEX Diesel Generator 2 Fails to Start
		2.02E-01		EPS-XHE-XM-NR01H	OPERATOR FAILS TO RECOVER EDG B IN 1 HOUR due to Start Air Issue
		7.60E-02		SD-XHE-XL-ELAP	Operator fails to recovery electrical distribution system after offsite power recovery

~~OFFICIAL USE ONLY – SECURITY-RELATED INFORMATION~~

~~OFFICIAL USE ONLY – SECURITY-RELATED INFORMATION~~

		2.70E-01		SD-XHE-XM-CROSSTIE	Operator Fails to Establish Div. 3 to Div. 2 Electrical Cross Tie
		5.11E-01		SD-XHE-XM-DEPB5B	Operator Fails to setup B5b Equipment for Depressurization (dependent)
21	C	3.48E-06	0.72	0-SD-M4L-LOOP : 3-24	
		1.68E-01		SD-M4L-LOOP	Loss of Offsite Power - M4 LATE
		1.00E-01		DEP-B5B	B5b Equipment for Opening SRVs
		2.02E-01		EPS-XHE-XM-NR01H	OPERATOR FAILS TO RECOVER EDG B IN 1 HOUR due to Start Air Issue
		5.00E-02		FLEX-ELEC-CONNECT	FLEX Electrical Connection Fails due to Design or Construction
		7.60E-02		SD-XHE-XL-ELAP	Operator fails to recovery electrical distribution system after offsite power recovery
		2.70E-01		SD-XHE-XM-CROSSTIE	Operator Fails to Establish Div. 3 to Div. 2 Electrical Cross Tie
22	C	3.32E-06	0.68	0-SD-M4L-LOOP : 3-24	
		1.68E-01		SD-M4L-LOOP	Loss of Offsite Power - M4 LATE
		7.20E-02		EPS-DGN-FS-FDG1	FLEX Diesel Generator 1 Fails to Start
		7.20E-02		EPS-DGN-FS-FDG2	FLEX Diesel Generator 2 Fails to Start
		2.02E-01		EPS-XHE-XM-NR01H	OPERATOR FAILS TO RECOVER EDG B IN 1 HOUR due to Start Air Issue
		1.37E-01		OEP-XHE-XL-NR10H	OPERATOR FAILS TO RECOVER OFFSITE POWER IN 10 HOURS
		2.70E-01		SD-XHE-XM-CROSSTIE	Operator Fails to Establish Div. 3 to Div. 2 Electrical Cross Tie
		5.11E-01		SD-XHE-XM-DEPB5B	Operator Fails to setup B5b Equipment for Depressurization (dependent)
		1.00E+00		TTCU-10	Time to Core Uncovery 10 hours or greater
23	C	2.82E-06	0.58	0-SD-M4L-LOOP : 3-24	
		1.68E-01		SD-M4L-LOOP	Loss of Offsite Power - M4 LATE
		1.00E-01		DEP-B5B	B5b Equipment for Opening SRVs
		1.50E-01		EPS-DGN-FR-FDG1	FLEX Diesel Generator 1 Fails to Run
		1.50E-01		EPS-DGN-FR-FDG2	FLEX Diesel Generator 2 Fails to Run
		2.02E-01		EPS-XHE-XM-NR01H	OPERATOR FAILS TO RECOVER EDG B IN 1 HOUR due to Start Air Issue
		1.37E-01		OEP-XHE-XL-NR10H	OPERATOR FAILS TO RECOVER OFFSITE POWER IN 10 HOURS
		2.70E-01		SD-XHE-XM-CROSSTIE	Operator Fails to Establish Div. 3 to Div. 2 Electrical Cross Tie
		1.00E+00		TTCU-10	Time to Core Uncovery 10 hours or greater
24	C	2.67E-06	0.55	0-SD-M4L-LOOP : 3-24	
		1.68E-01		SD-M4L-LOOP	Loss of Offsite Power - M4 LATE
		1.50E-01		EPS-DGN-FR-FDG1	FLEX Diesel Generator 1 Fails to Run
		5.00E-02		EPS-DGN-XR-FDG	FLEX Diesel 2 (portable) Fails due to Improper Transport or Setup
		2.02E-01		EPS-XHE-XM-NR01H	OPERATOR FAILS TO RECOVER EDG B IN 1 HOUR due to Start Air Issue
		7.60E-02		SD-XHE-XL-ELAP	Operator fails to recovery electrical distribution system after offsite power recovery
		2.70E-01		SD-XHE-XM-CROSSTIE	Operator Fails to Establish Div. 3 to Div. 2 Electrical Cross Tie
		5.11E-01		SD-XHE-XM-DEPB5B	Operator Fails to setup B5b Equipment for Depressurization (dependent)
25	C	2.37E-06	0.49	0-SD-M4L-LOOP : 3-24	
		1.68E-01		SD-M4L-LOOP	Loss of Offsite Power - M4 LATE
		2.02E-01		EPS-XHE-XM-NR01H	OPERATOR FAILS TO RECOVER EDG B IN 1 HOUR due to Start Air Issue
		5.00E-02		FLEX-ELEC-CONNECT	FLEX Electrical Connection Fails due to Design or Construction
		1.37E-01		OEP-XHE-XL-NR10H	OPERATOR FAILS TO RECOVER OFFSITE POWER IN 10 HOURS
		5.11E-01		SD-XHE-XM-DEPB5B	Operator Fails to setup B5b Equipment for Depressurization (dependent)

~~OFFICIAL USE ONLY – SECURITY-RELATED INFORMATION~~

~~OFFICIAL USE ONLY – SECURITY-RELATED INFORMATION~~

		1.00E+00		TTCU-10	Time to Core Uncovery 10 hours or greater
		2.00E-02		XTIE-ELEC-CONNECT	Div. 3 to Div. 2 Cross Tie Fails due to Design
26	C	2.32E-06	0.48	0-SD-M4L-LOOP : 3-24	
		1.68E-01		SD-M4L-LOOP	Loss of Offsite Power - M4 LATE
		1.00E-01		DEP-B5B	B5b Equipment for Opening SRVs
		2.02E-01		EPS-XHE-XM-NR01H	OPERATOR FAILS TO RECOVER EDG B IN 1 HOUR due to Start Air Issue
		1.37E-01		OEP-XHE-XL-NR10H	OPERATOR FAILS TO RECOVER OFFSITE POWER IN 10 HOURS
		2.50E-01		SD-XHE-XM-FELEC	Operator Fails to Setup and Run FLEX DG and Electrical Distribution
		1.00E+00		TTCU-10	Time to Core Uncovery 10 hours or greater
		2.00E-02		XTIE-ELEC-CONNECT	Div. 3 to Div. 2 Cross Tie Fails due to Design
27	C	2.31E-06	0.47	0-SD-M4L-LOOP : 3-24	
		1.68E-01		SD-M4L-LOOP	Loss of Offsite Power - M4 LATE
		7.20E-02		EPS-DGN-FS-FDG1	FLEX Diesel Generator 1 Fails to Start
		5.00E-02		EPS-DGN-XR-FDG	FLEX Diesel 2 (portable) Fails due to Improper Transport or Setup
		2.02E-01		EPS-XHE-XM-NR01H	OPERATOR FAILS TO RECOVER EDG B IN 1 HOUR due to Start Air Issue
		1.37E-01		OEP-XHE-XL-NR10H	OPERATOR FAILS TO RECOVER OFFSITE POWER IN 10 HOURS
		2.70E-01		SD-XHE-XM-CROSSTIE	Operator Fails to Establish Div. 3 to Div. 2 Electrical Cross Tie
		5.11E-01		SD-XHE-XM-DEPB5B	Operator Fails to setup B5b Equipment for Depressurization (dependent)
		1.00E+00		TTCU-10	Time to Core Uncovery 10 hours or greater
28	C	2.23E-06	0.46	0-SD-M4L-LOOP : 3-24	
		1.68E-01		SD-M4L-LOOP	Loss of Offsite Power - M4 LATE
		3.39E-02		EPS-DGN-FR-DG1C	DIESEL GENERATOR 1C FAILS TO RUN
		2.02E-01		EPS-XHE-XM-NR01H	OPERATOR FAILS TO RECOVER EDG B IN 1 HOUR due to Start Air Issue
		5.00E-02		FLEX-ELEC-CONNECT	FLEX Electrical Connection Fails due to Design or Construction
		7.60E-02		SD-XHE-XL-ELAP	Operator fails to recovery electrical distribution system after offsite power recovery
		5.11E-01		SD-XHE-XM-DEPB5B	Operator Fails to setup B5b Equipment for Depressurization (dependent)
29	C	2.20E-06	0.45	0-SD-M4L-LOOP : 3-24	
		1.68E-01		SD-M4L-LOOP	Loss of Offsite Power - M4 LATE
		3.70E-03		EPS-DGN-LR-DG1C	DIESEL GENERATOR 1C FAILS TO LOAD RUN
		2.02E-01		EPS-XHE-XM-NR01H	OPERATOR FAILS TO RECOVER EDG B IN 1 HOUR due to Start Air Issue
		1.37E-01		OEP-XHE-XL-NR10H	OPERATOR FAILS TO RECOVER OFFSITE POWER IN 10 HOURS
		5.11E-01		SD-XHE-XM-DEPB5B	Operator Fails to setup B5b Equipment for Depressurization (dependent)
		2.50E-01		SD-XHE-XM-FELEC	Operator Fails to Setup and Run FLEX DG and Electrical Distribution
		1.00E+00		TTCU-10	Time to Core Uncovery 10 hours or greater
30	C	2.19E-06	0.45	0-SD-M4L-LOOP : 3-24	
		1.68E-01		SD-M4L-LOOP	Loss of Offsite Power - M4 LATE
		1.00E-01		DEP-B5B	B5b Equipment for Opening SRVs
		3.39E-02		EPS-DGN-FR-DG1C	DIESEL GENERATOR 1C FAILS TO RUN
		2.02E-01		EPS-XHE-XM-NR01H	OPERATOR FAILS TO RECOVER EDG B IN 1 HOUR due to Start Air Issue
		7.60E-02		SD-XHE-XL-ELAP	Operator fails to recovery electrical distribution system after offsite power recovery
		2.50E-01		SD-XHE-XM-FELEC	Operator Fails to Setup and Run FLEX DG and Electrical Distribution

~~OFFICIAL USE ONLY – SECURITY-RELATED INFORMATION~~

From: [Kozak, Laura](#)
To: [Hunter, Christopher](#)
Subject: RE: Clinton and Perry Issues
Date: Wednesday, October 17, 2018 7:37:00 AM
Attachments: [CLI 2018 051.docx](#)

Chris

We sent out a preliminary White finding for Clinton (attached), on Monday. We are not working anything on Perry – I will need to check into it.

Laura

From: Hunter, Christopher
Sent: Wednesday, October 17, 2018 6:17 AM
To: Kozak, Laura <Laura.Kozak@nrc.gov>
Subject: Clinton and Perry Issues

Laura,

I hope you are well. Have you finalized the Clinton EDG issue yet?

I am also looking at an issue at Perry where a failed fuse took out train A of ECCS (although it may have just been the automatic function on the LOCA signal)... LER [440-2018-002](#) isn't completely clear. Are you working this?

Thanks,
Chris

Sr. Reliability and Risk Engineer
RES/DRA/PRB
T-10A50
Phone: (301) 415-1394 (Wednesday)
Home Phone:
Mobile Phone:
Email: Christopher.Hunter@nrc.gov

(b)(6)

(b)(6)



UNITED STATES
NUCLEAR REGULATORY COMMISSION
REGION III
2443 WARRENVILLE ROAD, SUITE 210
LISLE, ILLINOIS 60532-4352

October 15, 2018

EA-18-104

Mr. Bryan C. Hanson
Senior VP, Exelon Generation Company, LLC
President and CNO, Exelon Nuclear
4300 Winfield Road
Warrenville, IL 60555

SUBJECT: CLINTON POWER STATION—NRC INSPECTION REPORT 05000461/2018051
AND PRELIMINARY WHITE FINDING

Dear Mr. Hanson:

On September 24, 2018, the U.S. Nuclear Regulatory Commission (NRC) presented the preliminary significance assessment results to your staff at Clinton Power Station, Unit 1.

This letter transmits a finding that has preliminarily been determined to be White. A White finding low to moderate safety significance that may require additional NRC inspections. As described in this letter, on May 17, 2018, an apparent violation of Title 10 of the *Code of Federal Regulations* (10 CFR) Part 50, Appendix B, Criterion V, "Instructions, Procedures, and Drawings," and Technical Specification 3.8.2, Condition B.3, were self-revealed for the licensee's failure to follow multiple procedures that affected quality. This resulted in the unavailability and inoperability of the Division 2 Emergency Diesel Generator (EDG) when it was relied upon for plant safety. During part of the time that the Division 2 EDG was unavailable the Division 1 EDG was already out of service for planned maintenance. During the period when neither EDG was available a loss of offsite power would have resulted in a station blackout condition that could have resulted in a long term loss of the ability to cool the reactor core. This finding was assessed based on the best available information, using the applicable Significance Determination Process (SDP). Included in the body of the enclosed inspection report is the basis for the staff's preliminary determination of significance.

Your corrective actions included (1) returning the Division 2 EDG to an operable status; (2) communicating accountability and emphasis on procedure use and adherence; (3) just in time training to all operations department staff on the procedure use requirements; (4) conducting a three-day stand down to discuss case studies and lessons learned; and (5) revising the equipment operator round points to include the EDG starting air manifold pressures. The finding is also an apparent violation of NRC requirements and is being considered for escalated enforcement action in accordance with the Enforcement Policy, which can be found on the NRC's Web site at <http://www.nrc.gov/about-nrc/regulatory/enforcement/enforce-pol.html>.

Enclosure contains Sensitive Unclassified
Non-Safeguards Information. When
separated from attachment 2, this
transmittal document is decontrolled.

In accordance with NRC Inspection Manual Chapter 0609, we intend to complete our evaluation

B. Hanson

- 2 -

using the best available information and issue our final determination of safety significance within 90 days of the date of this letter. The significance determination process encourages an open dialogue between the NRC staff and the licensee; however, the dialogue should not impact the timeliness of the staff's final determination.

Before we make a final decision on this matter, we are providing you with an opportunity to (1) attend a Regulatory Conference where you can present to the NRC your perspective on the facts and assumptions the NRC used to arrive at the finding and assess its significance; or (2) submit your position on the finding to the NRC in writing. If you request a Regulatory Conference, it should be held within 40 days of the receipt of this letter and we encourage you to submit supporting documentation at least one week prior to the conference in an effort to make the conference more efficient and effective. The focus of the Regulatory Conference is to discuss the significance of the finding and not necessarily the root cause(s) or corrective action(s) associated with the finding. If a Regulatory Conference is held, it will be open for public observation. If you decide to submit only a written response, such submittal should be sent to the NRC within 40 days of your receipt of this letter. If you decline to request a Regulatory Conference or to submit a written response, you relinquish your right to appeal the final SDP determination, in that by not doing either, you fail to meet the appeal requirements stated in the Prerequisite and Limitation sections of Attachment 2 of NRC Inspection Manual Chapter 0609.

If you choose to send a response, it should be clearly marked as a "Response to An Apparent Violation; (EA-18-104)" and should include for the apparent violation: (1) the reason for the apparent violation or, if contested, the basis for disputing the apparent violation; (2) the corrective steps that have been taken and the results achieved; (3) the corrective steps that will be taken; and (4) the date when full compliance will be achieved. Your response should be submitted under oath or affirmation and may reference or include previously docketed correspondence, if the correspondence adequately addresses the required response. Additionally, your response should be sent to the U.S. Nuclear Regulatory Commission, ATTN: Document Control Center, Washington, DC 20555-0001 with a copy to K. Stodter, Chief, Branch 1, Division of Reactor Projects, U.S. Nuclear Regulatory Commission, Region III, 2443 Warrenville Road, Suite 210, Lisle, IL 60532-4352, within 40 days of the date of this letter. If an adequate response is not received within the time specified or an extension of time has not been granted by the NRC, the NRC will proceed with its enforcement decision or schedule a Regulatory Conference.

Please contact Ms. Karla Stodter at 630-829-9731, and in writing within 10 days from the issue date of this letter to notify the NRC of your intentions. If we have not heard from you within 10 days, we will continue with our significance determination and enforcement decision. The final resolution of this matter will be conveyed in separate correspondence.

Because the NRC has not made a final determination in this matter, no Notice of Violation is being issued for these inspection findings at this time. In addition, please be advised that the characterization of the apparent violation described above may change as a result of further NRC review.

B. Hanson

- 3 -

This letter will be made available for public inspection and copying at <http://www.nrc.gov/reading-rm/adams.html> and at the NRC Public Document Room in accordance with 10 CFR 2.390, "Public Inspections, Exemptions, Requests for Withholding."

However, the enclosed report contains Security-Related Information, so the enclosed report will not be made publically available in accordance with 10 CFR 2.390(d)(1). If you choose to provide a response that contains Security-Related Information, please mark your entire response "Security-Related Information–Withhold from public disclosure under 10 CFR 2.390" in accordance with 10 CFR 2.390(d)(1) and follow the instructions for withholding in 10 CFR 2.390(b)(1). The NRC is waiving the affidavit requirements for your response in accordance with 10 CFR 2.390(b)(1)(ii).

Sincerely,

/RA/

Patrick L. Loudon, Director
Division of Reactor Projects

Docket No. 50–461
License No. NPF–62

Enclosures:
Inspection Report 05000461/2018051
Attachment 1 (public)
Attachment 2 (non-public)

cc: W. Marsh, Clinton Station Security Manager
A. Khayyat, State Liaison Officer
Illinois Emergency Management Agency

cc w/o attach 2: Distribution via LISTSERV®

B. Hanson

- 4 -

Letter to Bryan Hanson from Patrick Louden dated October 15, 2018

SUBJECT: CLINTON POWER STATION—NRC INSPECTION REPORT 05000461/2018051
AND PRELIMINARY WHITE FINDING

DISTRIBUTION w/attachments:

Daryl Johnson
Niry Simonian
Eric Wharton
Alonzo Richardson
Raymond McKinley
Binoy Desai
Steven West
Darrell Roberts
Jeremy Groom

DISTRIBUTION:

Christopher Cook
RidsNrrDorLpI3
RidsNrrPMClinton Resource
RidsNrrDirslrib Resource
Steven West
Darrell Roberts
Richard Skokowski
Allan Barker
DRSIII
DRPIII
ROPreports.Resource@nrc.gov

ADAMS Accession Number: ML18289A436

OFFICE	RIII	RIII	RIII	OE
NAME	CPhillips:bw	LKozak	JHeller for KLambert	MMarshfield via email for JPeralta
DATE	10/11/2018	10/11/2018	10/12/2018	10/12/2018
OFFICE	NRR	RIII	RIII	
NAME	MFranovich via email	KStoedter	PLouden	
DATE	10/12/2018	10/15/2018	10/15/2018	

OFFICIAL RECORD COPY

U.S. NUCLEAR REGULATORY COMMISSION
REGION III

Docket Numbers: 50-461

License Numbers: NPF-62

Report Number: 05000461/2018051

Enterprise Identifier: I-2018-051-0000

Licensee: Exelon Generation Company, LLC

Facility: Clinton Power Station

Location: Clinton, IL

Dates: August 3 through September 4, 2018

Inspectors: C. Phillips, Project Engineer
L. Kozak, Senior Reactor Analyst
J. Mitman, Senior Reliability and Risk Analyst

Approved by: K. Stoedter, Chief
Branch 1
Division of Reactor Projects

SUMMARY

The U.S. Nuclear Regulatory Commission (NRC) completed the preliminary significance determination associated with an apparent violation in accordance with the Reactor Oversight Process. The Reactor Oversight Process is the NRC's program for overseeing the safe operation of commercial nuclear power reactors. Refer to <https://www.nrc.gov/reactors/operating/oversight.html> for more information. Findings and violations being considered in the NRC's assessment are summarized in the table below.

List of Findings and Violations

Failure to Follow Multiple Procedures			
Cornerstone	Significance	Cross-Cutting Aspect	Report Section
Mitigating Systems	Preliminary White AV 05000461/2018050-01 Open EA-18-104	[H.2] – Human Performance, Field Presence	93812-Special Inspection
On August 23, 2018, the NRC issued Inspection Report 05000461/2018050 which discussed a self-revealed finding with a To-Be-Determined (TBD) significance and an associated Apparent Violation of Title 10 of the Code of Federal Regulations (10 CFR) Part 50, Appendix B, Criterion V, "Instructions, Procedures, and Drawings," and Technical Specification 3.8.2, Condition B.3. The issue involved the licensee's failure to follow multiple procedures that affected quality which resulted in the unavailability and inoperability of the Division 2 Emergency Diesel Generator when it was relied upon for plant safety.			

Additional Tracking Items

None.

INSPECTION SCOPE

Inspections were conducted using the appropriate portions of the inspection procedure (IP) in effect at the beginning of the inspection unless otherwise noted. Currently approved IPs with their attached revision histories are located on the public website at <http://www.nrc.gov/reading-rm/doc-collections/insp-manual/inspection-procedure/index.html>. Samples were declared complete when the IP requirements most appropriate to the inspection activity were met consistent with Inspection Manual Chapter (IMC) 2515, "Light-Water Reactor Inspection Program - Operations Phase." The inspectors reviewed selected procedures and records, observed activities, and interviewed personnel to assess licensee performance and compliance with Commission rules and regulations, license conditions, site procedures, and standards.

OTHER ACTIVITIES—TEMPORARY INSTRUCTIONS, INFREQUENT AND ABNORMAL

93812—Special Inspection

The purpose of this inspection was to complete the preliminary significance determination for an apparent violation 10 CFR Part 50, Appendix B, Criterion V and Technical Specification 3.8.2, Condition B.3. documented in NRC Special Inspection Report 05000461/2018050.

INSPECTION RESULTS

93812—Special Inspection

Failure to Follow Multiple Procedures			
Cornerstone	Significance	Cross-Cutting Aspect	Report Section
Mitigating Systems	Preliminary White AV 05000461/2018050-01 Open EA-18-104	[H.2] – Human Performance, Field Presence	93812–Special Inspection
On August 23, 2018, the NRC issued Inspection Report 05000461/2018050 which discussed a self-revealed finding with a To-Be-Determined (TBD) significance and an associated Apparent Violation of Title 10 of the <i>Code of Federal Regulations</i> (10 CFR) Part 50, Appendix B, Criterion V, "Instructions, Procedures, and Drawings," and Technical Specification 3.8.2, Condition B.3. The issue involved the licensee's failure to follow multiple procedures that affected quality which resulted in the unavailability and inoperability of the Division 2 Emergency Diesel Generator when it was relied upon for plant safety.			
<u>Description:</u> On April 30, 2018, the licensee shut down the reactor as part of a scheduled refueling outage. During the outage, the licensee performed maintenance on the Division 2 electrical system which required the Division 2 emergency diesel generator (EDG) to be removed from service. From May 9-11, 2018, the licensee completed activities to restore the Division 2 EDG to service. Due to the failure to follow multiple procedures (as discussed in NRC Inspection Report 05000461/2018050), the Division 2 EDG was not restored to an operable status because operations personnel had not repositioned starting air valves 1DG160 and 1DG161			

from the closed position to the open position. With the starting air valves in the closed position, the Division 2 EDG was unable to start if needed.

On May 14, 2018, at 12:30 a.m., since the licensee was unaware that the Division 2 EDG was inoperable and unavailable due to its inability to start caused by the 1DG160 and 1DG161 valves being closed, the licensee began a Division 1 scheduled maintenance window. As a result of taking the Division 1 480 VAC bus out of service, the Division 1 EDG was declared inoperable.

On May 17, 2018, at 3:03 p.m., a non-licensed operator performing shift rounds identified that the 1DG160 and 1DG161 valves were closed and reported this condition to the control room. The licensee declared the Division 2 EDG inoperable, investigated the condition, and subsequently returned the Division 2 EDG to an operable status.

Corrective Actions: The licensee initiated several corrective actions including (1) communicating accountability and emphasis on procedure use and adherence; (2) just in time training to all operations department staff on the procedure use requirements; (3) conducting a three-day stand down to discuss case studies and lessons learned; and (4) revising the equipment operator round points to include the EDG starting air manifold pressures.

Corrective Action Reference: Action Request (AR) 4138790, "Division 2 DG Air Receiver Found Isolated Rounds," dated May 17, 2018.

Performance Assessment:

Performance Deficiency: The licensee failed to perform activities affecting quality in accordance with prescribed procedures and work instructions as required by 10 CFR Part 50, Appendix B, Criterion V, "Instructions, Procedures and Drawings," that resulted in the unavailability of the Division 2 EDG when it was relied upon for plant safety.

Screening: The inspectors determined the performance deficiency was more than minor because it adversely affected the configuration control attribute of the Mitigating Systems Cornerstone and its objective of ensuring the availability, reliability, and capability of systems that respond to initiating events to prevent undesirable consequences. Specifically, the failure to follow station procedures/work instructions resulted in the unavailability of the Division 2 EDG when it was relied upon for plant safety.

Significance: The inspectors evaluated the finding against the guidance of IMC 0609 Appendix G, Attachment 1, "Shutdown Operations Significance Determination Process Phase 1 Initial Screening and Characterization of Findings." The finding impacted the Mitigating Systems Cornerstone, specifically the Electric Power Availability Safety Function. The finding represented a loss of system safety function for the EDGs for greater than its TS 3.8.2, Condition B.3, allowed outage time of "Immediately" (one of the two EDGs was required to be returned to an operable status immediately) which required a Phase 2 Appendix G evaluation.

The Phase 2 evaluation was conducted using IMC 0609 Appendix G, Attachment 3, and "Phase 2 Significance Determination Process Template for BWR during Shutdown." A Region III senior reactor analyst (SRA) completed the Phase 2 evaluation and concluded that a Phase 3, or detailed risk evaluation, would be needed to refine the Phase 2 evaluation.

Summary from Special Inspection Report

The detailed risk evaluation (DRE) covered a 6.5 day period when the Division 2 EDG was inadvertently unavailable during a refueling outage.

The Division 2 EDG had been inoperable and unavailable as part of planned Division 2 480 VAC electrical distribution and Emergency Service Water (SX) systems maintenance activities. When the Division 2 systems work was completed and the systems restored on May 11, 2018 (at 2:30 a.m.), operators incorrectly declared the Division 2 EDG available. At this time, the Division 2 EDG starting air isolation valves (1DG160 and 1DG161) remained closed, which would prevent starting air from reaching the EDG air start motors, making the EDG inoperable, unavailable, and non-functional because it would not and could not be started on any demand signal.

On May 14, 2018, at 12:30 a.m., as the licensee was unaware that the Division 2 EDG was unavailable, the licensee began a scheduled maintenance window on the Division 1 480 VAC bus 1A1. As a result of taking the bus out of service, the Division 1 EDG was declared inoperable. At this time neither Division 1 nor 2 EDG was functional.

On May 17, 2018, at 3:03 p.m., a non-licensed operator performing shift rounds identified the 1DG160 and 1DG161 valves were inappropriately closed and reported this condition to the control room. The licensee declared the Division 2 EDG inoperable and investigated the condition. The licensee restored the valves to the open position and declared the Division 2 EDG available at 3:45 p.m. After the licensee performed OP-AA-108-106, the licensee declared the Division 2 EDG operable at 9:04 p.m.

During the 6.5 day period the Division 2 EDG was not operable, available, or functional as the licensee expected. During the 3.5 day period from May 14th to May 17th, neither the Division 1 nor 2 EDG was available to deal with a Loss of Offsite Power (LOOP) if one occurred.

As described in Inspection Report 2018050, a Phase 1 Significance Determination Process (SDP) screening and a phase 2 SDP evaluation were completed for the finding using the guidance of IMC 0609 Appendix G, "Shutdown Operations Significance Determination Process". As a result, the NRC determined that a detailed risk evaluation was needed to further evaluate recovery strategies. These strategies included 1) restoration of the Division 2 EDG; 2) plant-specific mitigating system strategies such as the Division 3 cross-tie to Division 2; 3) use of Diverse and Flexible Coping Strategies (FLEX), and 4) the recovery of offsite power. As a result the inspection report initially characterized the significance of this finding as "to be determined."

Summary of Preliminary (Phase 3) Significance Determination

The Clinton SPAR model, revision 8.54 was modified to add a shutdown Mode 4 cold shutdown Loss of Offsite Power (LOOP) event tree based on the existing Grand Gulf shutdown SPAR model. The model was further modified to use Clinton specific system fault trees and to refine diesel generator recovery, incorporate FLEX electrical, FLEX suppression pool cooling, FLEX injection, potential recovery of high pressure core spray (HPCS) pump, recovery of reactor core isolation cooling (RCIC), use of alternate injection systems such as installed fire pumps, B.5.b fire pumps, B.5.b reactor depressurization methods, manual containment venting capability, and the cross-tie of the Division 3 EDG to Division 2 electrical

distribution system. Human error probabilities in addition to equipment failure probabilities were added for all actions requiring manual alignment and operation.

The detailed risk evaluation considers the many different core cooling methods potentially available. However, the results indicate that successful mitigation of the event relies on operator action to restore AC power by one of several methods – recovery of the Division 2 EDG, FLEX electrical, Division 3 to Division 2 cross-tie, or offsite power recovery. The analysis is complex since mitigation of a LOOP event in the degraded condition significantly relies on operator actions and the decision making involving the interaction of these four recovery strategies. The risk results are driven by human error.

None of the many operator actions modeled to mitigate the postulated LOOP/SBO event were assumed to be resource limited. This is in recognition that the plant was in a refueling outage with extra operations, maintenance and engineering staff available. Few of the many actions modeled to mitigate the postulated LOOP/SBO were assumed to be limited by time available. However, the overall sequence was modeled assuming operators have one hour to recover the Division 2 EDG before an extended loss of AC power (ELAP) is declared. Once ELAP is declared, plant procedures direct the operators to pursue the FLEX method to re-power Division 2. If FLEX fails, procedures supply guidance on using the Division 3 cross-tie. For the dominant core damage sequence, the time to core damage is approximately 13 hours, this was considered to be adequate time with some margin, but not extra or expansive time, given the level of manual effort required and the number of concurrent methods of mitigation that were modeled.

The finding exposure time that was quantitatively assessed was the 3.5 day period that both emergency diesel generators were unavailable. The full exposure time was approximately 6.5 days. However, the risk results are dominated by the 3.5 days when neither diesel was available.

The result of the detailed risk evaluation is a finding of low to moderate safety significance (White). The best estimate change (i.e., delta) in core damage frequency for the 3.5 day period, using reasonable and realistic assumptions, was estimated to be $3.8E-6$ per year. The dominant sequence was a loss of offsite power, failure to recover the Division 2 EDG leading to an Extended Loss of AC Power (ELAP) declaration, failure to maintain the reactor depressurized, failure to inject at high pressure, and the failure to cross-tie the Division 4KV bus to the Division 2 4kV bus. Sensitivity evaluations were performed to understand the influence of important assumptions. The results of the sensitivity evaluations showed a range of outcomes from very low safety significance (Green) to substantial safety significance (Yellow). The sensitivity evaluations were used to confirm the best estimate outcome – low to moderate (White) safety significance. See Table 1. The specific important assumptions of the detailed risk evaluation, the event tree, fault trees, and dominant core damage cut-sets are included in the Enclosure.

Table 1: Risk Results Including Sensitivity Cases

	Notes	BE Adjusted	Old BE Value	New BE Value	Delta CDF Results	
Best Case Analysis		n/a	n/a	n/a	3.8E-06	
Sensitivity Cases:						
1	Div. 2 EDG available (i.e., no PD)	No change set required, simply use value for base case no PD	EPS-XHE-XR-DG1B	TRUE (1.0)	1.00E-03	5.4E-07
2	Div. 2 EDG non-recovery based on data 88%		EPS-XHE-LR-NR10H	2.0E-02	8.80E-01	1.7E-05
3	Div. 2 EDG non-recovery based Exelon estimate	Note that using Exelon's values reduces the CDF to less than the no PD case because the NRP is lower than the base EDG failure probability	EPS-XHE-LR-NR10H	2.0E-02	5.0E-03	1.0E-07
4	HPCS pump available during entire 3.5 day exposure time		HCS-XHE-XR-MDP	TRUE (1.0)	False (0.0)	6.2E-07
5	Single Human Error Probability (HEP) for all injection methods		Multiple BE	5.3E-05	1.0E-03	3.5E-06
6	Decrease RCIC HEP to 0.1		SD-XHE-XM-FRCIC	7.5E-01	1.0E-01	3.7E-06
7	Decrease FLEX Electrical HEP to Exelon value to 0.1		SD-XHE-XM-FELEC	2.5E-01	1.0E-01	2.4E-06
8	Reduce all FLEX HEPs by factor of 10		Multiple BE	Various	Decrease by 10X	6.7E-08
9	Set all FLEX HEPs to False (0.0)		Multiple BE	Various	False (0.0)	2.5E-08
10	Increase all FLEX HEPs by Factor of 2	Increase RCIC value from 0.75 to 1.0	Multiple BE	Various	Increase by 2X	2.9E-05
11	Using Exelon Initiating Event Frequency (IEF) of 0.12 per year	Exelon modified the IEF because the switchyard was protected Note: EDG2 was protected during 6.5 days of unavailability	SD-MFL-LOOP	1.7E-1	1.2E-1	2.8E-06

Cross-cutting Aspect: As discussed in Inspection Report 05000461/2018050, the finding had a cross-cutting aspect in the Field Presence component of the Human Performance cross-cutting area. (H.2)

Enforcement:

Apparent Violation: Title 10 CFR Part 50, Appendix B, Criterion V, "Instructions, Procedures, and Drawings," requires, in part, that activities affecting quality be prescribed by documented procedures of a type appropriate to the circumstances and be accomplished in accordance with these procedures.

Clearance Order 139455 instructions required the performance of CPS 3506.01P002, "Division 2 Diesel Generator Operations," Revision 3a, in conjunction with the removal of out-of-service tags on May 9, 2018.

Procedure OP-AA-108-103, "Locked Equipment Program," Revision 2, Step 4.1.5, stated, "If plant conditions require a locked component to be positioned in a manner other than that indicated on the locked equipment checklist or approved procedure, then UNLOCK and REPOSITION equipment in accordance with OP-AA-108-101, "Control of Equipment and System Status." Procedure OP-AA-108-101, "Control of Equipment and System Status," Revision 14, Step 4.1.1.1, stated, "Utilize an ACPS for aligning equipment outside of routine operations."

Procedure OP-AA-108-106, "Equipment Return to Service," Revision 5, Step 4.3, required that "if equipment will not be restored to the Equipment Line-up/Restoration position or the original condition, then another approved equipment status control mechanism shall be used to document equipment status (i.e. Equipment Status Tag, administrative clearance/tagout). Procedure OP-AA-108-101, 'Control of Equipment and System Status,' shall be used to document abnormal equipment configuration and shall be immediately applied following equipment restoration."

Procedure OP-AA-108-106, "Equipment Return to Service," Revision 5, Step 4.4.9, which stated, "Applicable Operating procedures are complete and any equipment line-ups directed to be completed by the Operating Procedures are completed."

Procedure OP-AA-108-106, "Equipment Return to Service," Revision 5, Step 4.4.14, stated, "The system/equipment has been walked down as appropriate to verify that it can be safely operated to fulfill its design function."

Procedure OP-AA-109-101, "Clearance and Tagging," Revision 12, Step 10.2.1 stated, "If a lift position is determined to be different from the normal lineup position for the present plant condition and not tracked by another C/O or procedure, then the Shift Management shall be notified and equipment tracking initiated."

Technical Specification 3.8.2, "AC Sources-Shutdown," Condition B.3, states, in part, that an inoperable EDG be restored to an operable status immediately.

Between May 9 and May 17, 2018, the licensee apparently failed to:

Perform CPS 3506.01P002, "Division 2 Diesel Generator Operations," Revision 3a, in

conjunction with the removal of C/O 139455 as required by the C/O restoration instructions.

Perform OP-AA-108-103, "Locked Equipment Program," Revision 2, Step 4.3, valves 1DG160 and 1DG161 were normally locked open valves and an ACPS was not utilized to track valve status.

Perform OP-AA-108-106, "Equipment Return to Service," Revision 5, Step 4.3, when valves 1DG160 and 1DG161 were left in an abnormal position an approved equipment status control mechanism was not used to track equipment status.

Perform OP-AA-108-106, "Equipment Return to Service," Revision 5, Step 4.4.9, when the equipment was declared operable the applicable operating procedure CPS 3506.01P002 had not been completed and equipment line-ups directed to be completed by the operating procedures were not completed.

Perform OP-AA-108-106, "Equipment Return to Service," Revision 5, Step 4.4.14, when the system was declared operable without being walked down.

Perform OP-AA-109-101, "Clearance and Tagging," Revision 12, Step 10.2.1, when the lift position was different from the normal lineup for the present plant condition and equipment tracking was not initiated.

Additionally, because the licensee was not aware of the EDG's inoperability the required action in Technical Specification 3.8.2, Condition B.3 was not followed.

EXIT MEETINGS AND DEBRIEFS

The inspectors confirmed that proprietary information was controlled to protect from public disclosure. No proprietary information was documented in this report.

- On September 24, 2018, Mr. P. Loudon presented the preliminary significance assessment results to Mr. T. Stoner, Clinton Power Station, Site Vice President.

DOCUMENTS REVIEWED

93812—Special Inspection

Detailed Risk Evaluation Assumptions

Plant Conditions during the Conditions Assessed

Clinton is a General Electric Boiling Water Reactor 6 with a Mark III containment. It has three divisions of Emergency Core Cooling (ECCS). Divisions 1 and 2 have residual heat removal (RHR) capability, each with an RHR train that contains a heat exchanger. Each division has its own emergency diesel generator (EDG) and 4kV safety bus. In addition, Division 3 contains a High Pressure Core Spray (HPCS) pump dedicated safety bus, and EDG₃ but does not contain an RHR train.

The Division 2 EDG unplanned unavailability started after the reactor had been refueled and the associated reactor cavity was full. That is, there was over 23 feet of water above the reactor core. Early in the unavailability, the licensee installed the reactor pressure vessel (RPV) internals, lowered water level to about six inches below the RPV flange, installed and tensioned the reactor vessel head. The unit entered cold shutdown or Mode 4 when the last reactor head bolt was tensioned. See Figure 1 for a time line of these events.

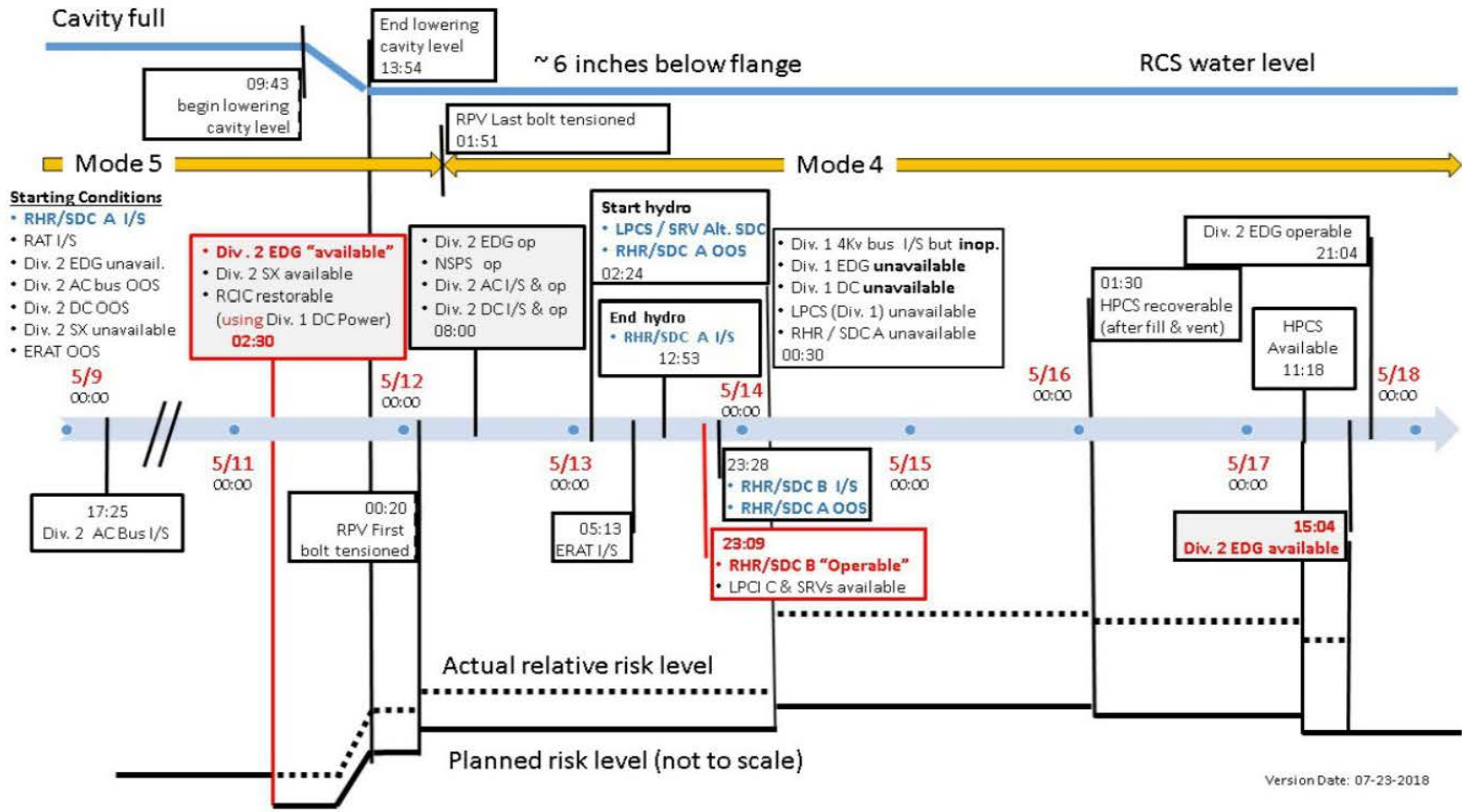

The following assumptions were made in performing the detailed risk evaluation.

1. The time to boil in the reactor coolant system was assumed to be approximately 4 hours, based on Exelon document CL-SDP-010 Rev. 1. This calculation assumes the starting water level is approximately six inches below the RPV flange.
2. The time to top of active fuel, a surrogate for core damage, varies from approximately 10 to 24 hours depending on plant configuration assumptions. These values were based on Exelon document CL-SDP-010 Rev. 1. If the reactor is maintained at low pressure, then the time to core uncover is about 24 hours. If the reactor pressure increases then the time to uncover is estimated between 10 and 13 hours. Both calculations assume the starting water level is approximately six inches below the RPV flange.
3. Core uncover is the normal at-power surrogate for core damage. During shutdown, core damage is expected between 1/3 and 2/3 core height which is somewhat after core uncover, therefore, using core uncover as a surrogate for core damage is conservative.
4. The following equipment was out of service and was considered to be unavailable and non-recoverable:
 - EDG 1A;
 - 480v AC bus 1A;
 - 480v AC bus A;
 - NSPS 120v Power distribution panel bus A;
 - Division 1 normal 125v DC battery charger 1A; and
 - RHR pump A.
5. The following equipment was available:
 - All FLEX equipment;
 - RHR train B;
 - RHR heat exchanger A;
 - Both suppression pool cleanup (SF) pumps and the associated piping (Note: there was a very short period at the beginning of the 3.5 days when one SF pump was not available. Because this availability was short and with the knowledge that the results are not driven by mitigating system availability, this unavailability was ignored.);
 - All B5b equipment;
 - 480v AC aux. building bus 1L;
 - 480v AC aux. building bus 1M;
 - 480v AC aux. building bus 1D;
 - 480v AC aux. building bus 1E (feed to 125v DC battery charger 1F); and
 - 125v DC battery (swing) charger 1F (feed from 480v AC aux. building bus 1E).
6. The NRC used the SPAR-H Human Reliability Method to evaluate the many operator actions in the model. For all of the human error probabilities evaluated, the performance shaping factor “stress” was considered to be “high” for both diagnosis and action because the plant would be in a station blackout condition. In many of the Human Error

Probability (HEP) evaluations, “complexity” was determined to be either “moderate” or “high” because the operators would be in multiple procedures in multiple plant locations. Many of the actions are local, infrequently or never performed, and some have very limited training. In many cases, “ergonomics” was also rated as “poor” because the local actions may be physically demanding and in difficult SBO conditions (on emergency lighting at best and without any ventilation). Table 2 below contains a summary of the dominant HEPs.

7. None of the many actions modeled to mitigate the postulated LOOP/SBO event were assumed to be resource limited. This is in recognition that the plant was in a refueling outage with extra operations, maintenance and engineering staff available. The detailed risk evaluation models operator action for four different methods to re-establish electrical power to Division 2 (EDG recovery, offsite power recovery, FLEX, Division 3 to Division 2 crosstie), two additional (beyond the normal use of SRVs after restoring emergency power) methods to maintain the reactor de-pressurized (FLEX and B.5.b), three additional methods (beyond using ECCS after restoring emergency power) to inject to the Reactor Coolant System (RCS) at low pressure (two FLEX methods and the diesel driven fire pumps), two methods to inject to the RCS at high pressure (HPCS and RCIC), and two additional methods to remove decay heat (FLEX suppression pool cooling and containment venting). All of these require operator action. Many require significant operator effort. In addition to these actions there are other important, non-modeled actions that would also be in progress, such as actions to establish primary and secondary containment and actions for emergency response such as accountability and notifications.
8. Few of the many actions modeled to mitigate the postulated LOOP/Station Black Out (SBO) were assumed to be limited by time available. However, the overall sequence was modeled assuming operators have 1 hour to recover the Division 2 EDG before ELAP is declared. Once ELAP is declared, operators will pursue the FLEX method to re-power Division 2. If FLEX fails, the Division 3 cross-tie, is modeled. For the dominant sequence, the time to core damage is approximately 13 hours, this was considered to be adequate time with some margin, but not extra or expansive time, given the level of manual effort required and the number of concurrent methods of mitigation that were modeled.
9. The high pressure core spray system was unavailable during most of the 3.5 day exposure period due to planned maintenance. Initially, for a period of 49 hours, it was not recoverable. Later, for a duration of 34 hours, it was modeled as recoverable, and in the last 4.5 hours of the exposure period, the system was fully available. The impact of the status of HPCS over the exposure period was addressed by running three separate cases – HPCS unavailable, HPCS recoverable, and HPCS at nominal failure probabilities. The results were combined in a spreadsheet to obtain the final result. To estimate the HEP for the operator failure to recover HPCS during the 44 hours it was recoverable, the performance shaping factors that were determined to be performance drivers were stress for diagnosis, and stress and complexity for action. Stress was evaluated as “high” because the plant would be in a station blackout condition. Complexity was rated as “moderate”. Under normal conditions, this would not be a complex task, but in response to a station blackout with multiple procedures and mitigating strategies in progress, complexity is increased.

10. The RCIC system was unavailable due to plant conditions. During the 3.5 days of interest, the plant was in cold shutdown with reactor coolant system water level above the steam lines. However, the RCIC system was not undergoing any maintenance and could have been put into service if an event had occurred, steam was available due to RCS heat-up and boiling, and water level had decreased below the steam line. While possible, extensive work would be required to prepare the RCS for operations at normal pressure and temperature. Licensee procedure CPS 3002.01 controlled this process. This 40 page document is the normal startup procedure. It assumes normal electrical power is available to realign systems. While much of this procedure would not be required to prepare the RCS for RCIC operation and extensive amount of procedure triage would be required. The HEP for the operator failure to put RCIC into service under the postulated conditions is $7.5E-1$. The HEP was dominated by failure to perform the action. The performance drivers were considered to be time (this is one of the few HEPs that was impacted by time available), stress, complexity, experience/training, and ergonomics. The time available was assumed to be about equal to the time required, stress was considered to be "high", complexity was "high", experience/training was "low", and ergonomics was "poor".
11. Electrical power recovery to Division 2 could be successful via offsite power recovery, recovery of Division 2 diesel generator, use of FLEX, or crosstie of the Division 3 diesel generator to the Division 2 4kV bus. The detailed risk evaluation assumes that the operators will initially try to recover the diesel generator. If recovery is not successful, operators will transition to FLEX implementation, and if FLEX fails, the evaluation models the potential to implement the crosstie.
12. The Division 2 EDG was recoverable and the risk evaluation shows that the operators would be very likely to recover it. However, the potential for operators failing to recover the diesel generator was evaluated. The failure to recover the diesel generator was assigned a human error probability of 0.202 (20 percent failure, 80 percent success rate). This is a factor of 4 lower than the data/statistically derived failure to recover probability. The NRC assumed that 1 hour was available to recover AC power to Division 2 by recovering the EDG. At 1 hour, ELAP declaration and implementation of FLEX electrical power to Division 2 would commence. Diesel generator recovery is further complicated by station blackout load shedding that removes all DC control power from the diesel generator and the FLEX electrical alignment which also impacts Division 2 EDG components. Recovery of the Division 2 EDG after 1 hour into an SBO does not represent successful recovery of Division 2 AC power. Operator actions to back out of ELAP, FLEX implementation, and load shedding to restore the EDG is not governed by procedures, is not a simple, skill of the craft task, and has no training. It was not credited in the risk evaluation consistent with general PRA/HRA assumptions and the Risk Assessment Standardization Project (RASP) guidance.
13. The human error probability for the failure to recover Division 2 EDG was estimated at 0.202. The performance shaping factors that were determined to be performance drivers were Stress and Experience/Training for Diagnosis, and Stress for Action. Stress was considered to be "high" because the plant would be in a station blackout condition. Experience/Training for Diagnosis was considered to "low." Plant staff perform troubleshooting as a regular job task, however, operators have not trained on, experienced or been exposed to troubleshooting a failure of the "protected" diesel generator during a shutdown SBO.

14. The human error probability for the failure to implement the FLEX electrical line-up was estimated at $2.5E-1$. The performance shaping factors that were determined to be performance drivers were stress for diagnosis and action, and complexity and experience/training for action. Stress was considered to be “high” because the plant would be in a station blackout condition. The action to align the FLEX electrical system was considered to be both “highly” complex and was assigned “low” experience/training. The procedure requires many in-plant actions under difficult conditions and the alignment has never been implemented.
15. The human error probability for the failure to implement the Division 3 to Division 2 crosstie was estimated at $2.7E-1$. The performance shaping factors that were determined to be performance drivers were stress for diagnosis and action, and complexity, experience/training, and ergonomics for action. Stress was considered to be “high” because the plant would be in a station blackout condition. The action to implement the cross-tie was considered to be “highly” complex and was assigned “low” experience/training and “poor” ergonomics. The procedure has both in-plant and control room actions in multiple locations and has received very little training.
16. Offsite power recovery is also modeled but is complicated by electrical system re-alignment when FLEX or the Division 3 cross-tie are attempted but fail. These strategies significantly alter the electrical distribution system. The detailed risk evaluation models offsite power non-recovery at 13 hours or 24 hours, depending on the sequence. The offsite power recovery curve is used along with a human error probability for the failure to realign the electrical system once other sources of power have been attempted but failed. The performance shaping factors that were considered to be performance drivers for the failure to realign the electrical system were stress for diagnosis and action and procedures for action. Stress was considered to be “high” because the plant would be in a station blackout condition. Procedures were considered to be “incomplete” as there are procedures for aligning offsite power sources but they would not specifically address the electrical alignment that would exist after FLEX and the crosstie have been attempted but not successfully implemented. The HEP was estimated at $7.61E-2$.
17. Alignment of alternate suppression pool cooling using FLEX equipment was modeled. The human error probability was estimated at $2.33E-1$. The performance shaping factors that were determined to be performance drivers were stress for diagnosis and action, and complexity, experience/training, and ergonomics for action. Diagnosis was considered to be “obvious” as the need for suppression pool cooling during SBO events is well understood. Stress was considered to be “high” because the plant would be in a station blackout condition. The action was considered to be “moderately” complex, have “low” experience/training, and “poor” ergonomics. The steps to perform the action are performed outside the control room in poor lighting and there is infrequent training and no actual experience. The procedure describes some of the steps as physically demanding and some are in high radiation areas.
18. Two methods of RCS Injection using FLEX equipment were modeled. The easier method would be to re-align the FLEX SPC method for injection. The human error probability for this action was estimated at $4E-3$. The less preferred method, using the diesel-driven FLEX pumps, was estimated at $1.1E-1$. For the easier method, the

performance shaping factors that were determined to be performance drivers were stress for diagnosis and action. The diagnosis was also assumed to be obvious, given that the FLEX suppression pool cooling alignment would already be in place and working successfully. Minimal additional action would be required to re-align the system for injection. The actions to use the less preferred method of direct injection from the lake with the diesel driven pumps was not an important action driving the results of the analysis.

19. Alignment of the ultimate heat sink using FLEX equipment was modeled. The human error probability was estimated at $1.39E-2$. The performance shaping factors that were determined to be performance drivers were stress for diagnosis and action and time, complexity, experience/training, and ergonomics for action. Diagnosis was considered to be "obvious" similar to the rating for aligning suppression pool cooling. Stress was considered to be "high" because the plant would be in station blackout condition. The time available for the action was considered to be greater than 5x the time required. Complexity was considered to be "moderate", experience/training "low", and ergonomics "poor". The steps to perform the action are performed outside the control room in poor lighting and there is infrequent training and no actual experience. The procedure describes some of the steps as physically demanding and some are in high radiation areas.
20. Use of B.5.b equipment and strategies to maintain the reactor depressurized was modeled with an operator action that was highly dependent on the operator action to use FLEX strategies. The FLEX strategy to maintain the reactor depressurized was assumed to be the preferred method. The human error probability for the dependent operator action was $5.2E-1$.
21. Primary containment was open during the exposure time. However, procedures would instruct operators to take action to establish primary containment. The detailed risk evaluation assumes that operators would take this action and would establish primary containment. If suppression pool cooling is not established, then containment venting would be required, consistent with at-power PRA model assumptions. Manual venting of containment was credited. These are long sequences containing success of core cooling via injection but failure to establish suppression pool cooling. These assumptions did not impact the dominant core damage sequences.
22. Alternate injection with fire water system was modeled with equipment failures and an operator action for the failure to align the system. This method was assumed to be the least preferred method of low pressure injection. The operator failure to align fire water injection was assigned an HEP of $1.2E-1$ and was not modeled as dependent on previous operator actions, a possible non-conservative assumption. These assumptions did not impact the dominant core damage sequences.
23. The FLEX diesel generators were assigned a failure to start of $7.2E-2$ and a failure to run for the mission time of $1.5E-1$. The failure to start was based on actual plant operating experience. The run time data for the diesel generators was very limited and could not be used to estimate the failure to run probability. The failure to run for emergency diesel generators was multiplied by a factor of 5 based on analyst judgement to obtain the failure to run rate of the FLEX diesel generator.

24. The FLEX diesel-driven pumps were assigned a failure to start of $1E-2$ and a failure to run of $2.1E-1$. Based on analyst judgment these failure rates we set at five times the corresponding failure rates for permanently installed diesel driven fire pumps.
25. FLEX equipment was assigned a failure probability due to design or construction of $5E-2$. The FLEX strategies, although carefully developed and reviewed for the Mitigating Strategies Order, have never been fully demonstrated. Latent design or construction errors could exist.
26. The Division 3 to the Division 2 cross-tie was assigned a failure probability due to design error of $2E-2$. Both divisions are normally in-service but never cross-tied and the cross-tie has never been fully demonstrated.

Table 2: Summary of Dominant HRA Results

(S)(U)

--

~~OFFICIAL USE ONLY - SECURITY RELATED INFORMATION~~

(b)(7)(D)



~~OFFICIAL USE ONLY - SECURITY RELATED INFORMATION~~

References

1. Clinton SPAR Model, Revision 8.54 with Modifications
2. NUREG-1842, "Good Practices for Implementing Human Reliability Analysis." April 2005
3. NUREG/CR-6595 Revision 1, "An Approach for Estimating the Frequencies of Various Containment Failure Modes and Bypass Events." October 2004
4. NUREG/CR-6883, "The SPAR-H Human Reliability Analysis Method"
5. INL/EXT-10-18533, "SPAR-H Step-by-Step Guidance"
6. RASP Manual Volume 1 – Internal Events, Revision 2.02 date December 2017
7. NUREG/CR-1278, "Handbook of HRA with Emphasis on Nuclear Power Plant Applications," August 1983
8. Analysis of Loss-of Offsite-Power Events 1987-2016, INL/EXT-17-42376 August 2017 (<https://nrc.nrel.gov/resultsdb/publicdocs/LOSP/loop-summary-update-2016.pdf>)
9. IMC 0609 Appendix G, "Shutdown Operations SDP"
10. NUMARC 91-06, "Guidelines for Industry Actions to Assess Shutdown Management." December 1991
11. CPS 3002.01 R32e Heatup and Pressurization
12. CPS 3312.03 R11d SDC and FPC Assist
13. CPS 3501.01 High Voltage Auxiliary Power System
14. CPS 3506.01 EDG and Support Systems
15. CPS 3506.01P002 Division 2 Diesel Generator Operations
16. CPS 4006.01 Loss of SDC
17. CPS 4200.01 Loss of AC Power
18. CPS 4200.01C002 DC Load Shedding during SBO
19. CPS 4303.01P001 Containment Venting Without AC Power Available
20. CPS 4303.01P004 SRV Operation With External DC Power
21. CPS 4303.01P023 Cross-Connecting Div. 3 DG to Div. 1(2) ECCS Electrical Busses
22. CPS 4306.01P001 FLEX Electrical Connection
23. CPS 4306.01P002 FLEX UHS Water Supply
24. CPS 4306.01P003 FLEX Suppression Pool Cooling
25. CPS 4306.01P004 FLEX Low Pressure RPV Makeup
26. CPS 4306.01P017 ELAP During Modes 4 and 5
27. CPS 5285_R27c Alarm Panel 5285 Annunciators at 1PL12JB
28. CPS 5061.07 Alarm Panel 5061 Annunciators – Row 7
29. CPS 4411.03 Injection Flooding Sources
30. CPS 4411.06 Emergency Containment Venting, Purging and Vacuum Relief
31. CPS 9065.01 Secondary Containment Access Integrity
32. EOP-1 RPV Control
33. EOP-2 RPV Flooding
34. EOP-3 Emergency RPV Depressurization (Blowdown)
35. EOP-6 Primary Containment Control
36. EOP-8 Secondary Containment Control
37. CC-AA-118 Corporate FLEX Process Guidance
38. OU-AA-103 Shutdown Safety Management Program
39. OU-CL-104 Shutdown Safety Management Program (Clinton Power Station)
40. CL-SDP-010 Risk Assessment – May 2018 Outage: Division 2 DG 1B Unavailable with Division 1 Bus Unavailable, Rev. 0
41. DB430301 DBIG-Extensive Damage Mitigation Guide, Rev. 5

- 42. N-CL-OPS-DB430601, FLEX, Rev. 0
- 43. SE-LOP-162, Extensive Damage Mitigation, Rev. 0
- 44. SE-LOR-4306, FLEX Event, Rev. 0

Event Tree and Fault Tree Figures

Figure 2: LOOP Event Tree 1

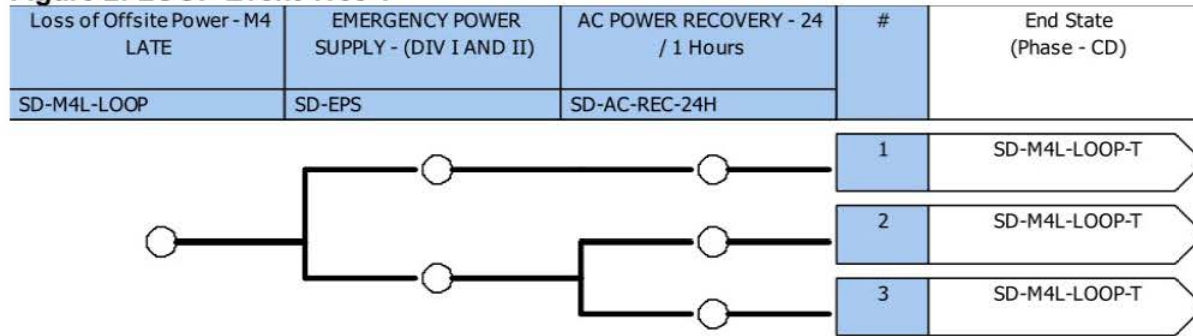

Figure 3: LOOP Event Tree 2

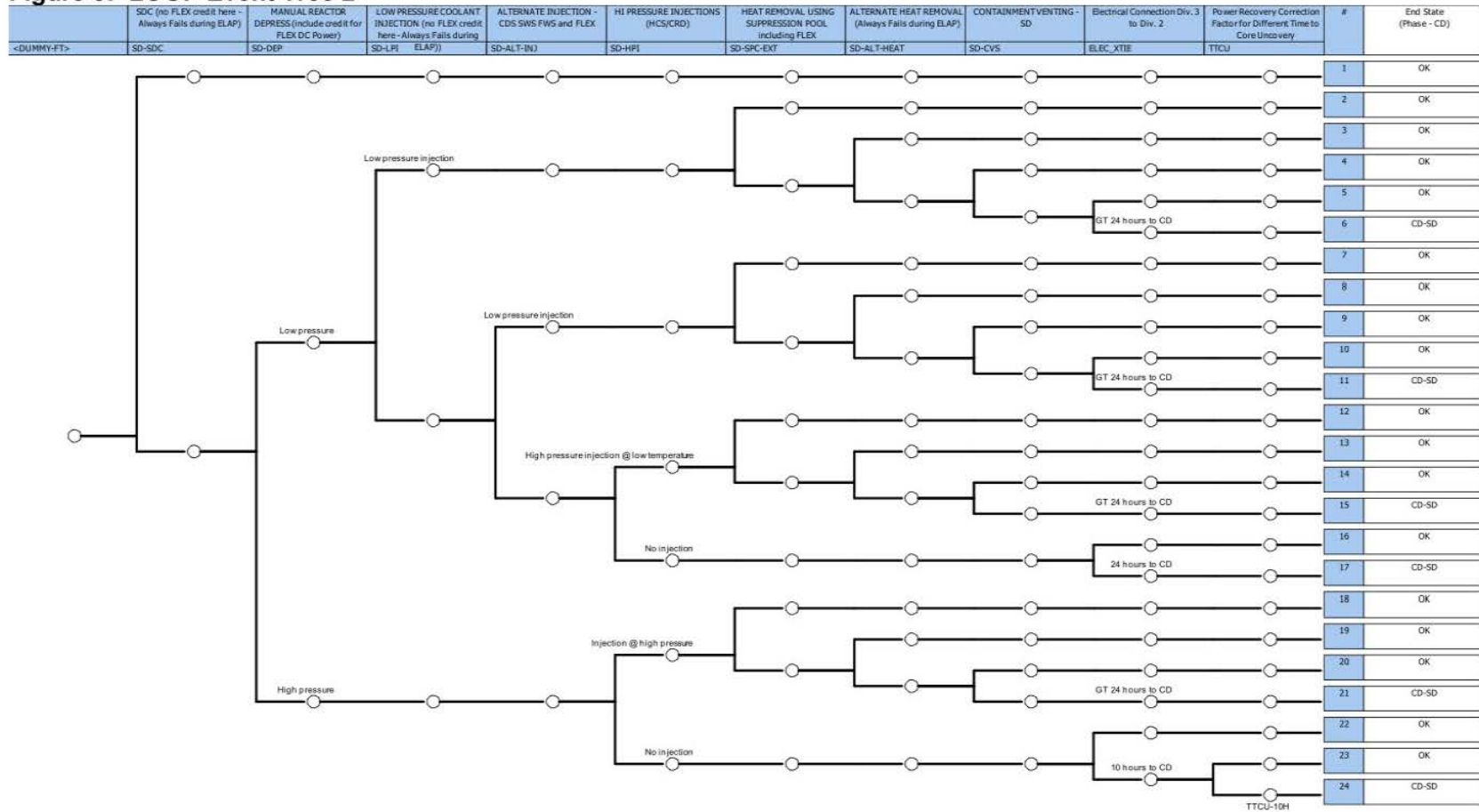

Figure 4: AC Power Recovery Fault Tree

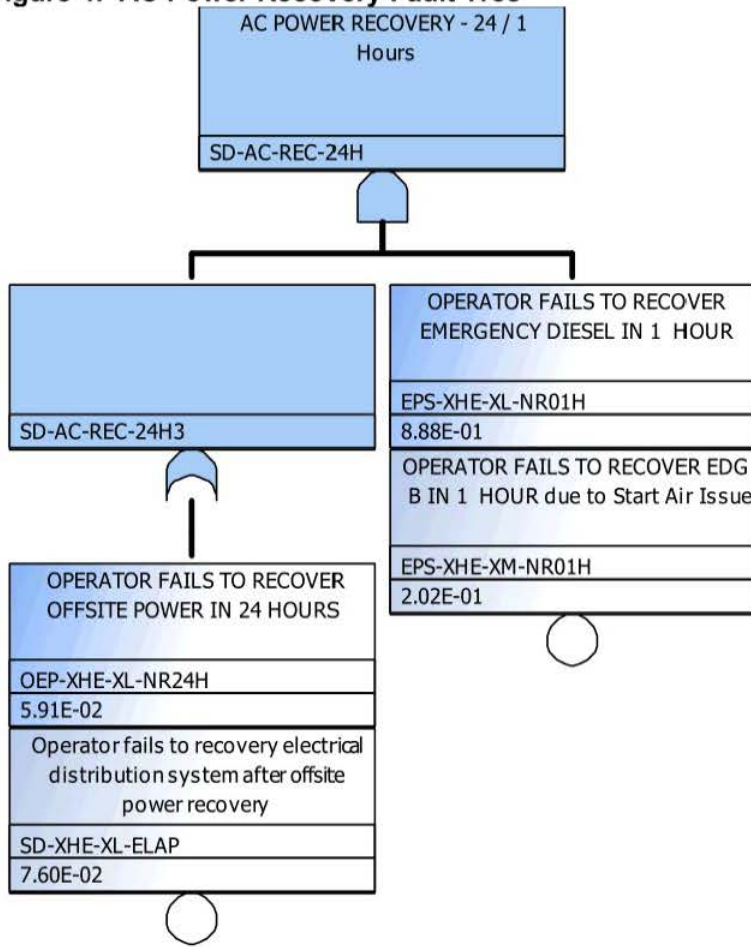

Figure 5: Manual Depressurization Fault Tree

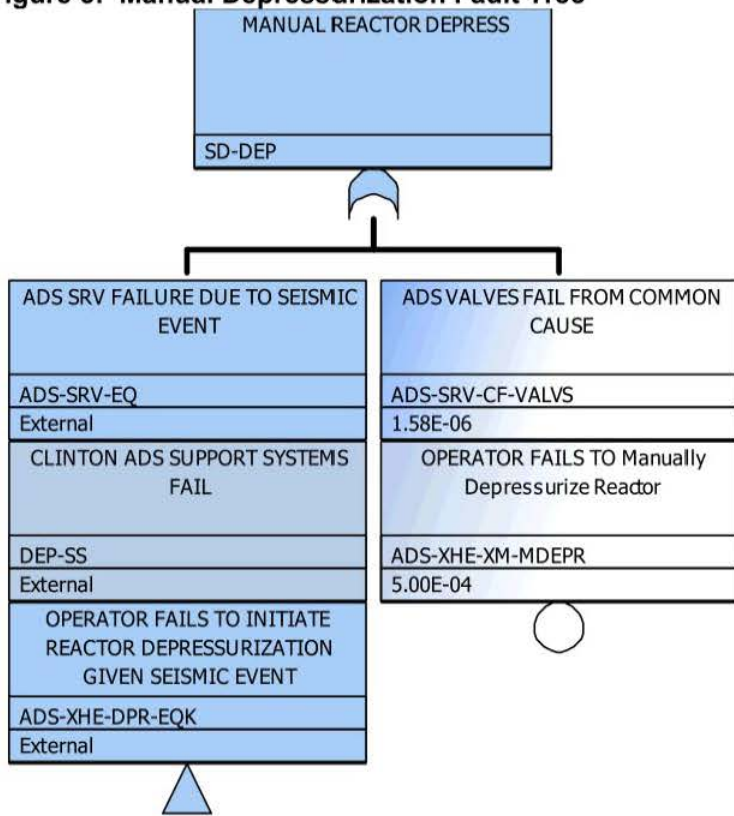

Figure 6: Division I 125 Power Fault Tree (shows FLEX linkage)

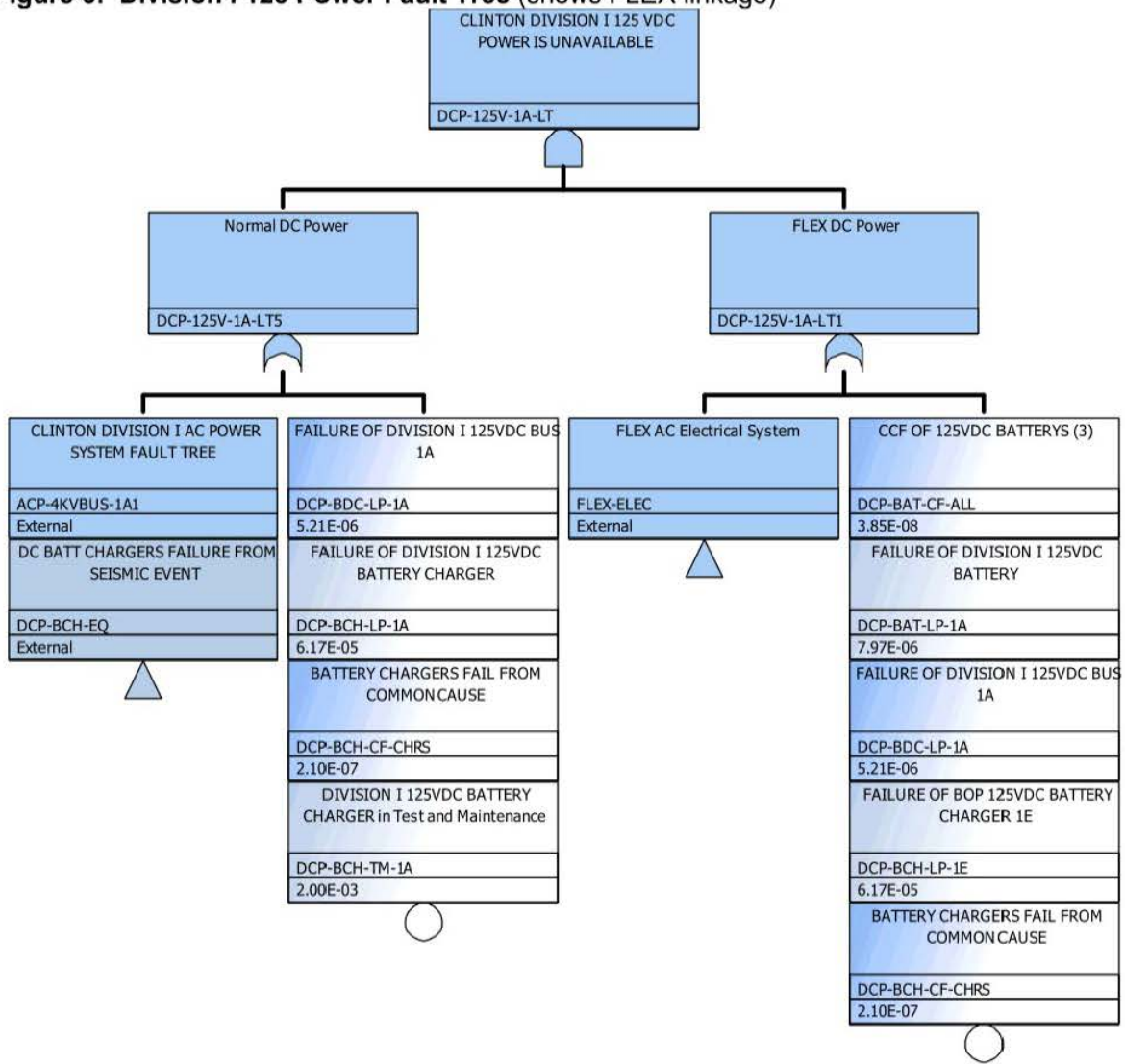

Figure 7: FLEX Electrical Fault Tree

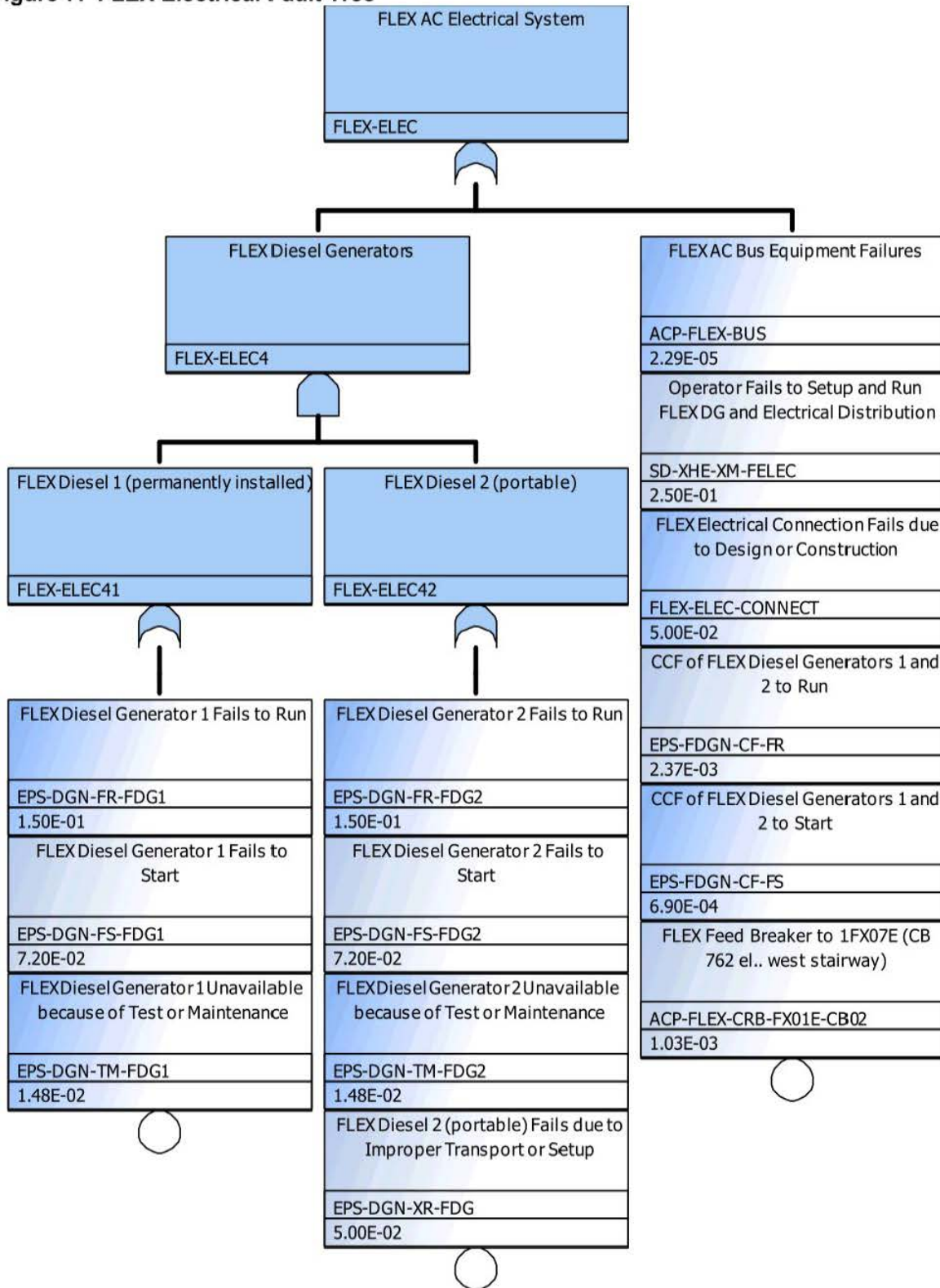

Figure 8: Alternate Injection Fault Tree (includes FLEX)

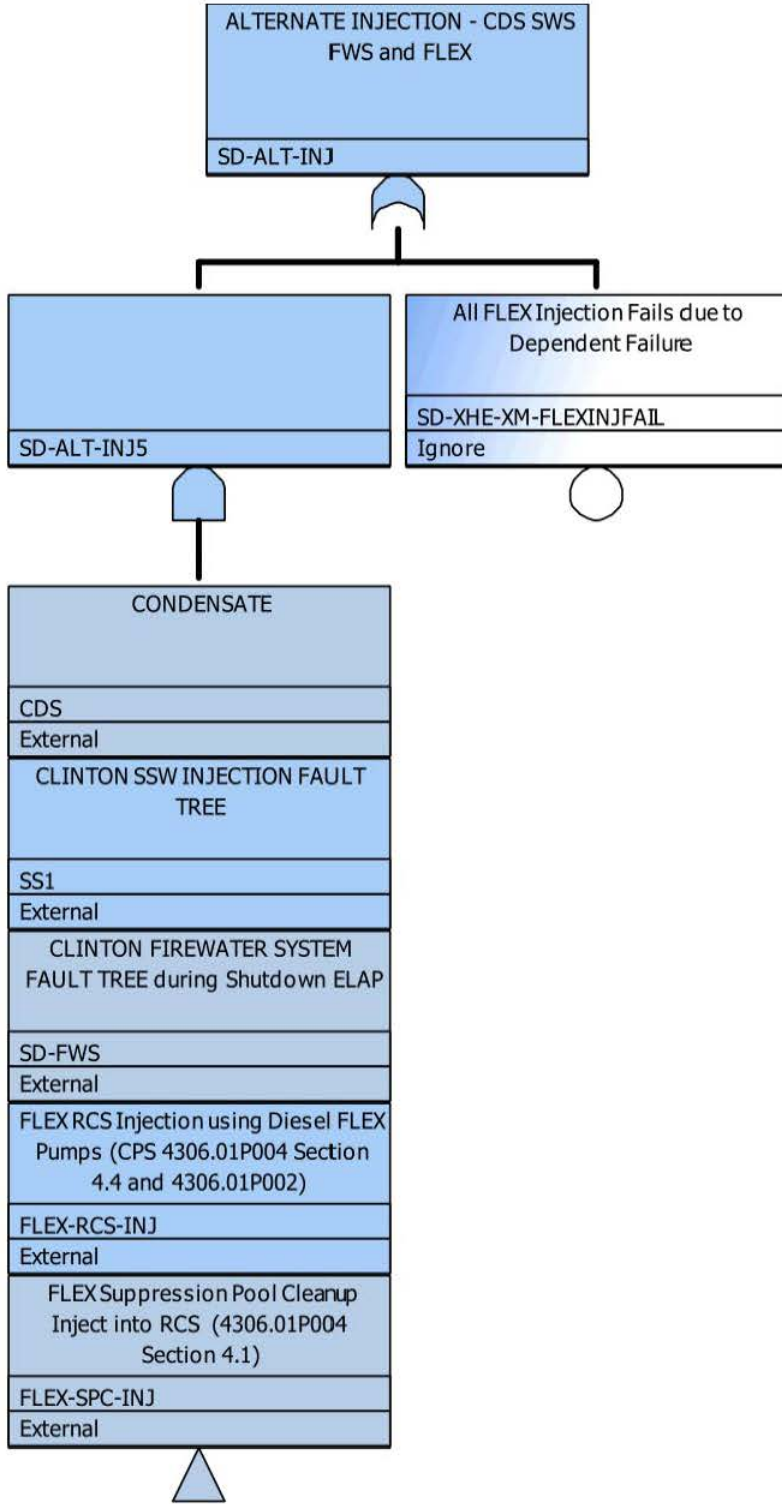

Figure 9: RCS Injection using FLEX Diesel Driven FLEX Pumps Fault Tree

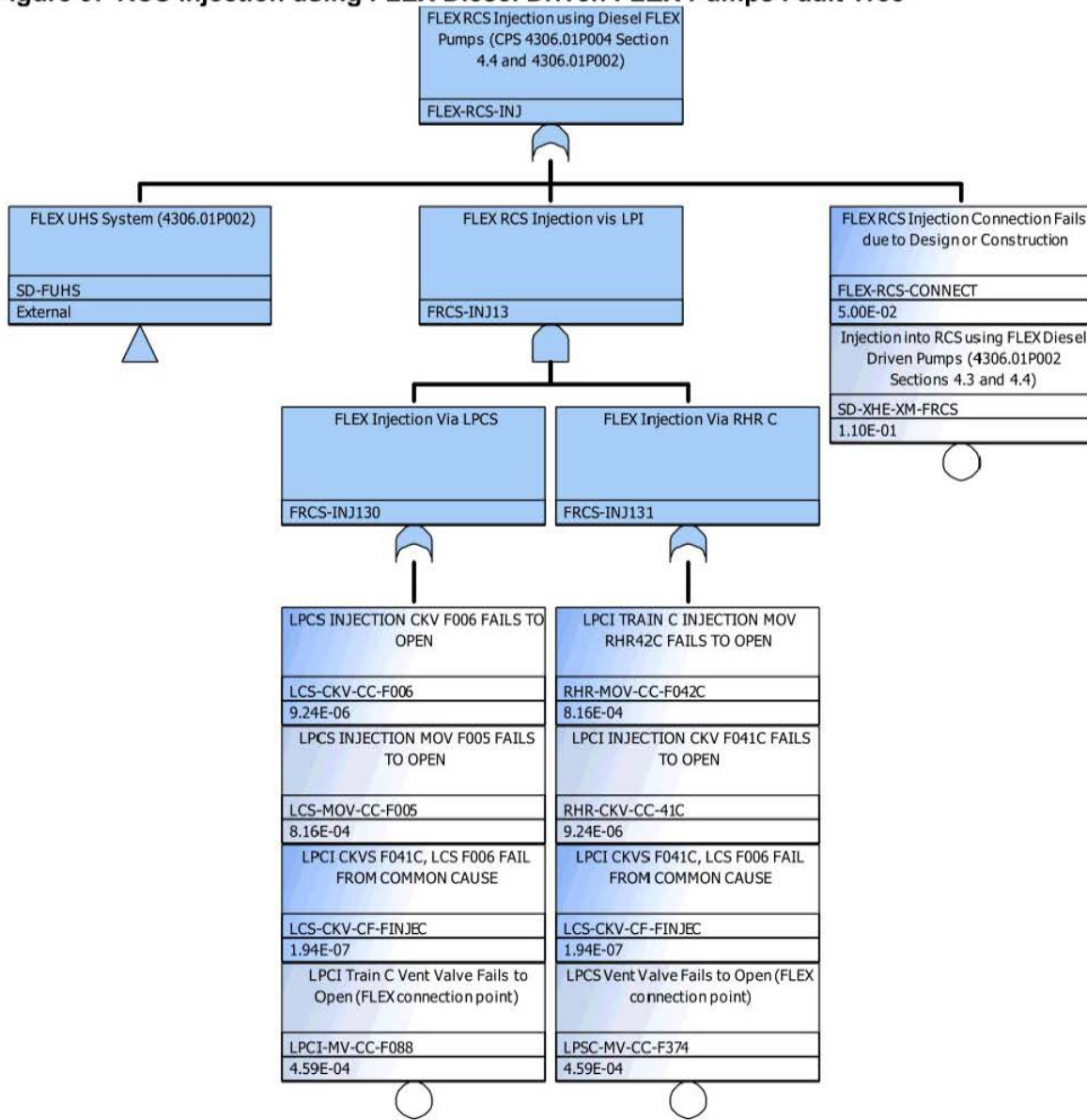

Figure 10: FLEX Ultimate Heat Sink System Fault Tree

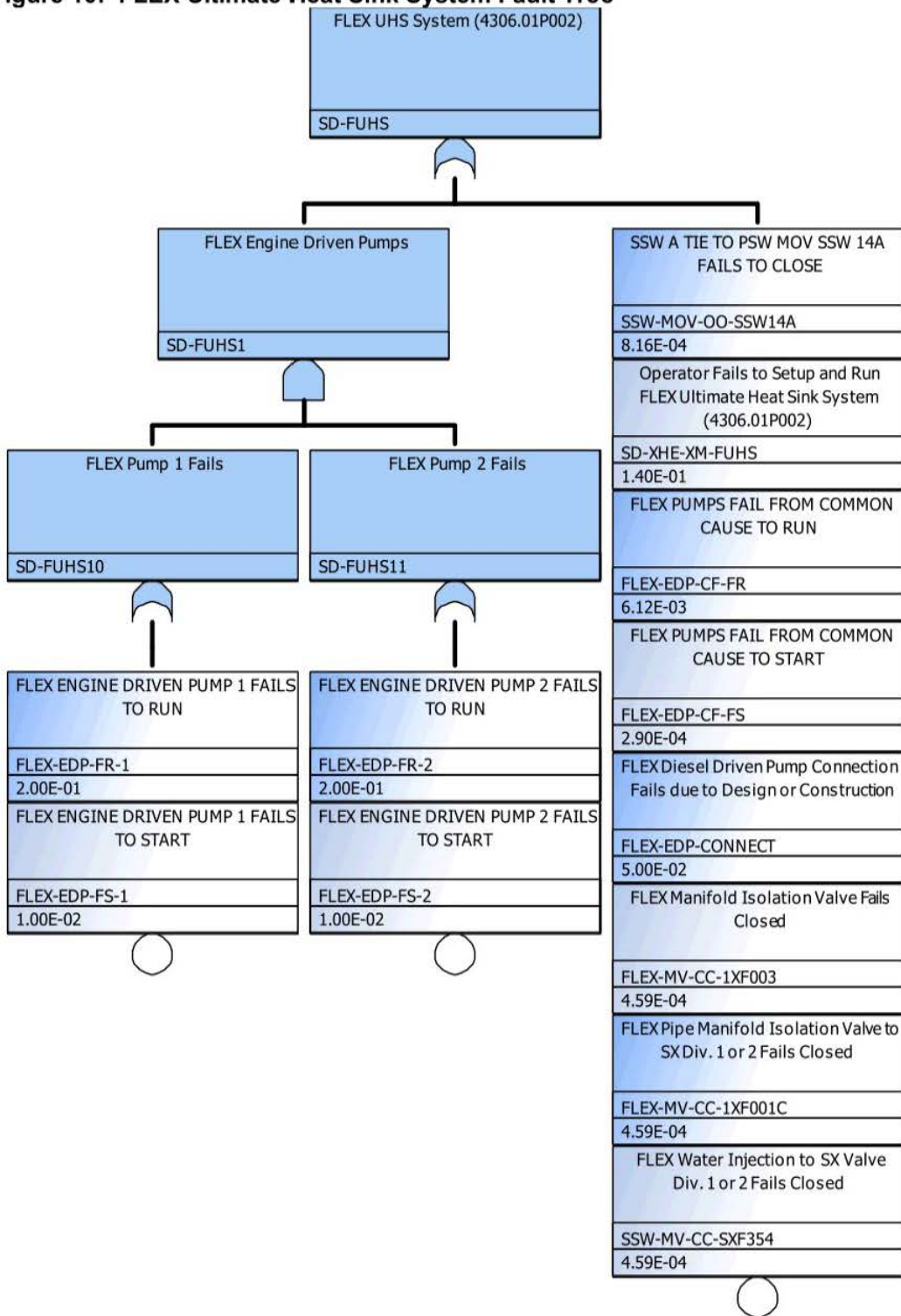

Figure 11: RCS Injection using FLEX Suppression Pool Cleanup Fault Tree

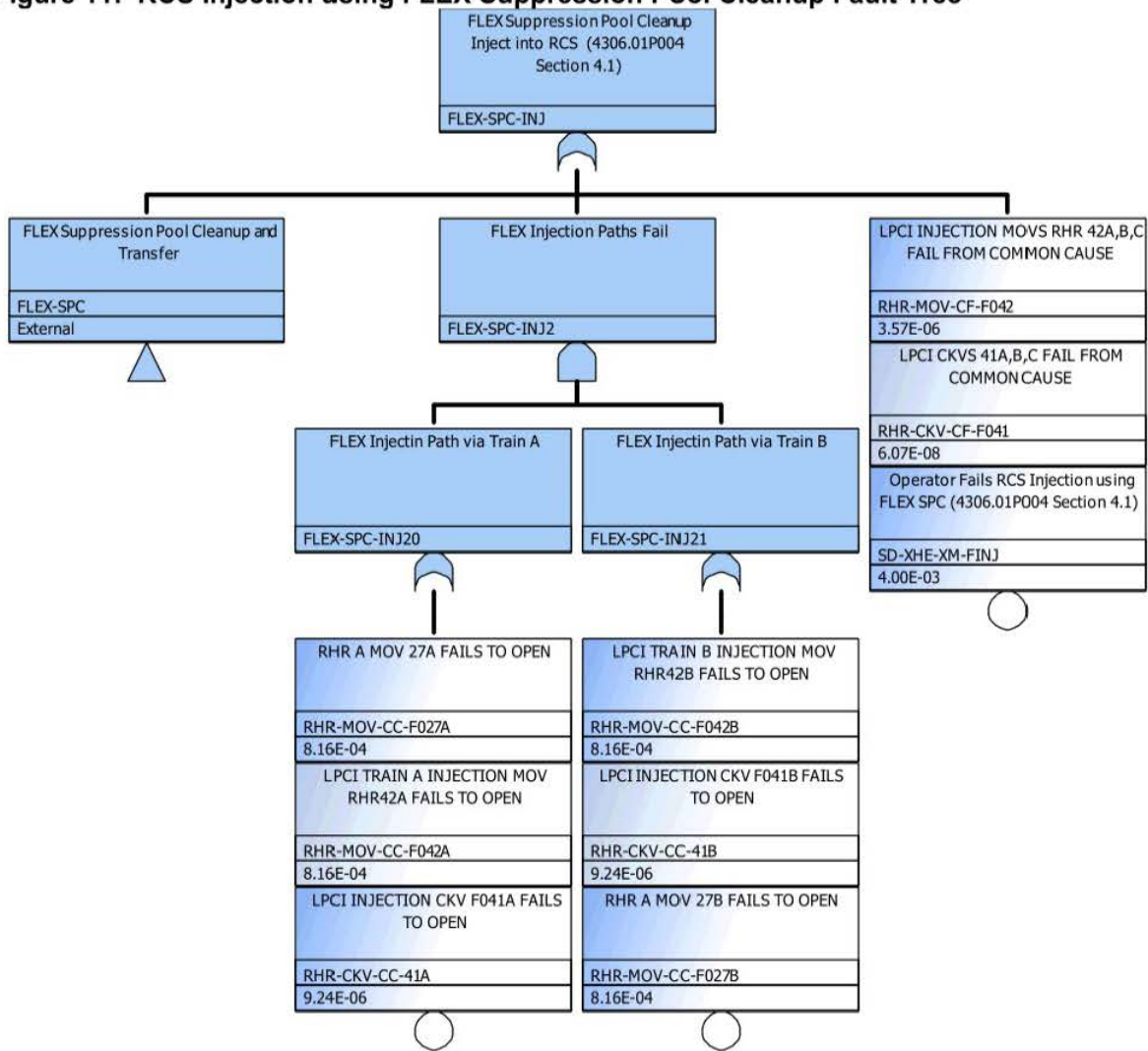

Figure 12: FLEX Suppression Pool Cleanup and Transfer Fault Tree

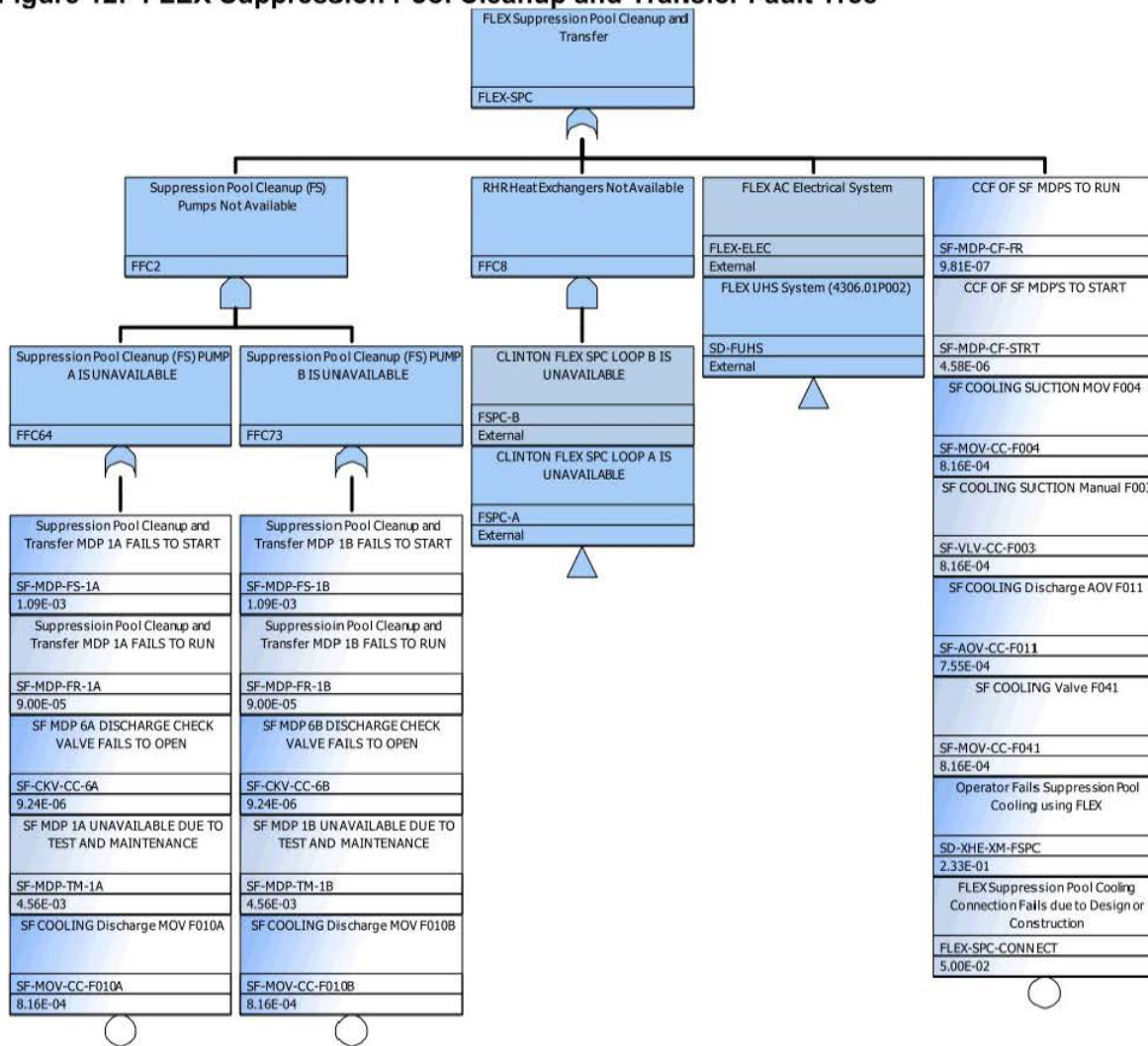

Figure 13: FLEX Suppression Pool Cooling using RHR Heat Exchanger A Fault Tree

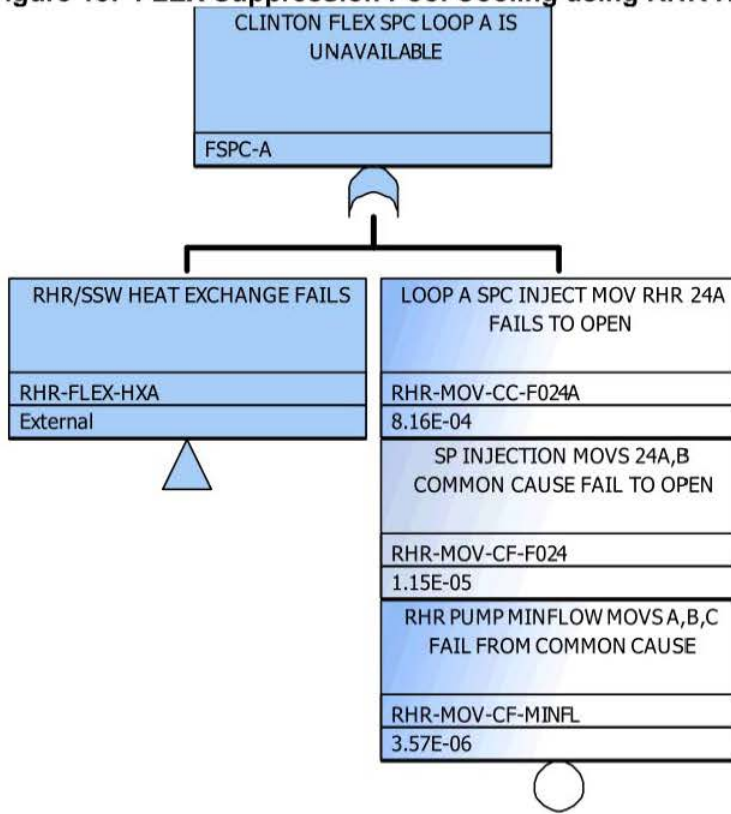

Figure 14: RHR Heat Exchanger A for FLEX SPC Fault Tree

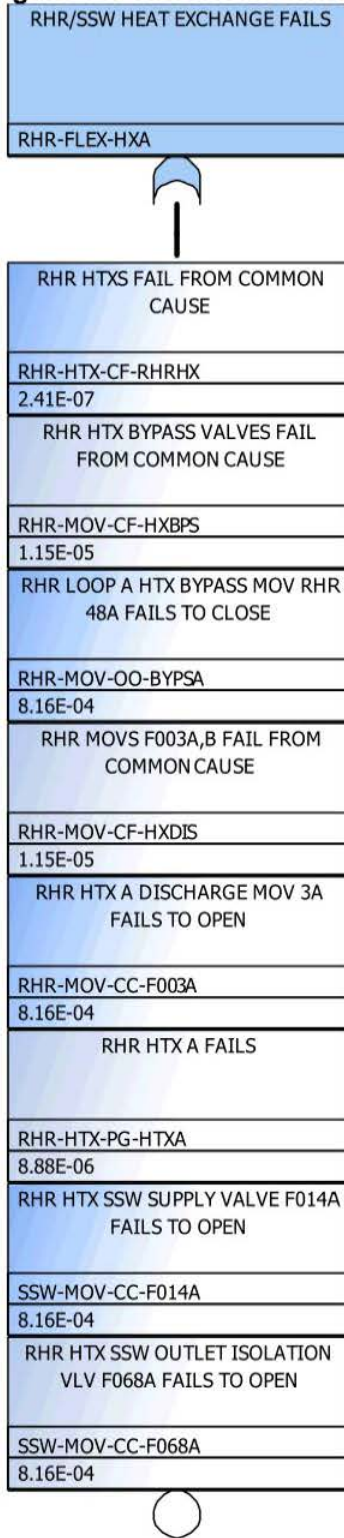

Figure 15: Containment Venting Fault Tree

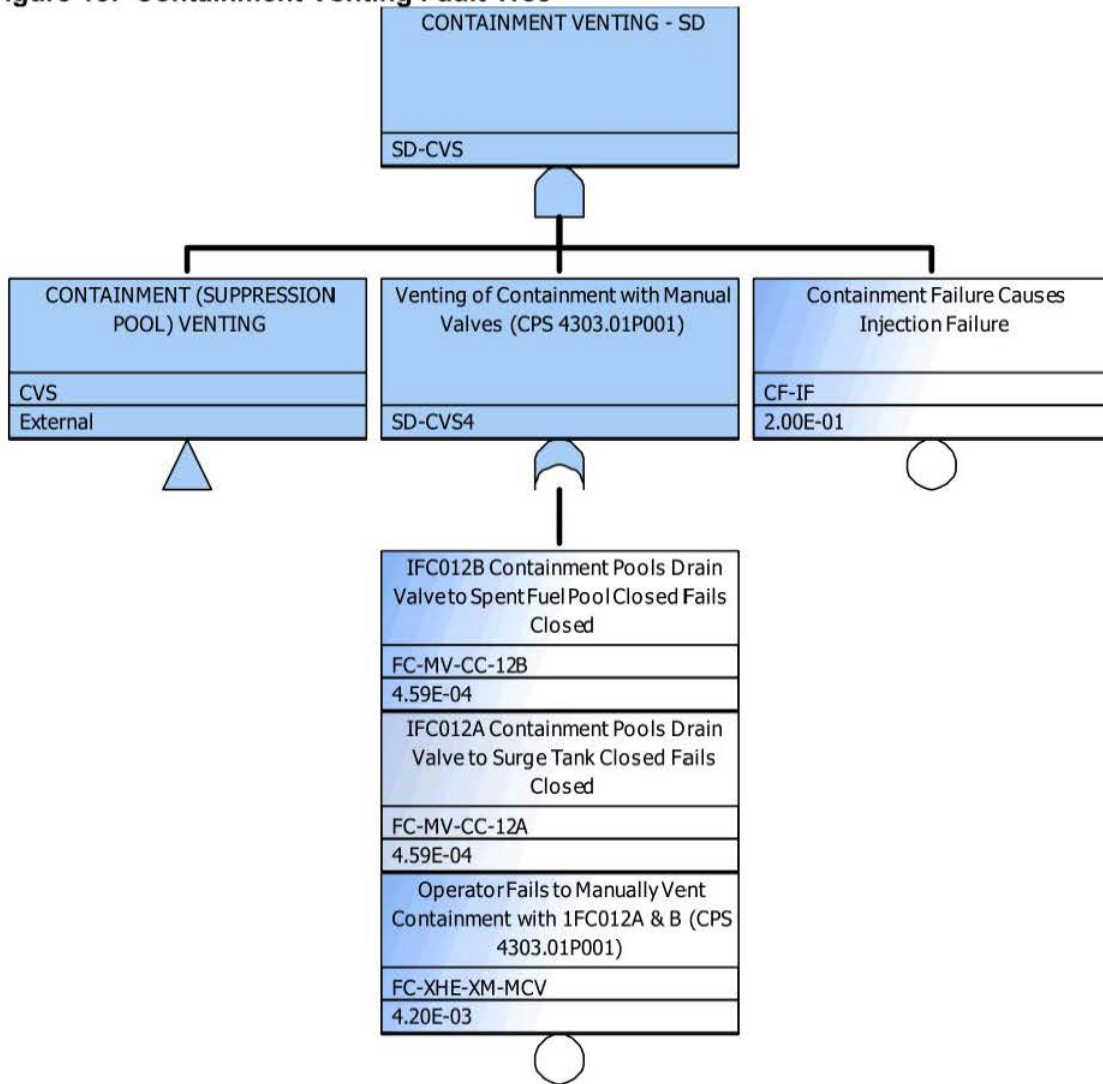

Figure 16: Electrical Cross-Tie Division 3 to Division 2 Fault Tree

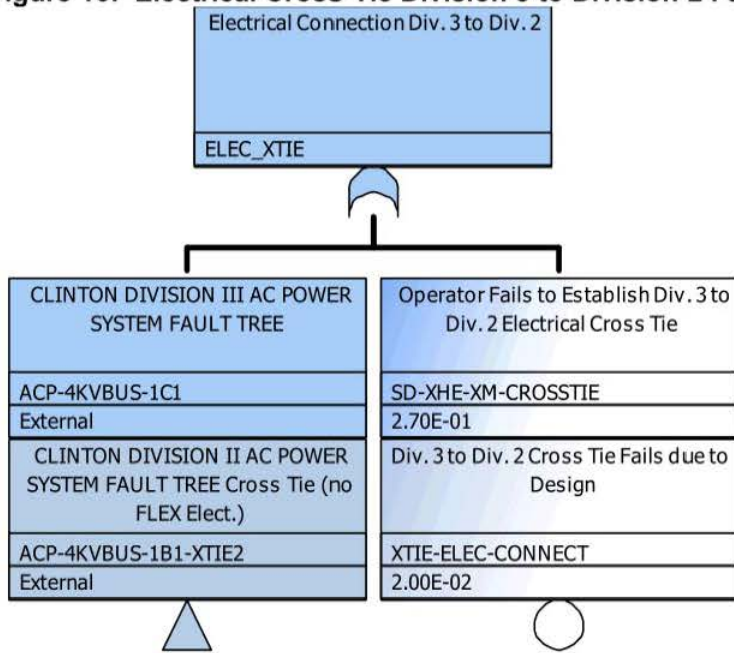
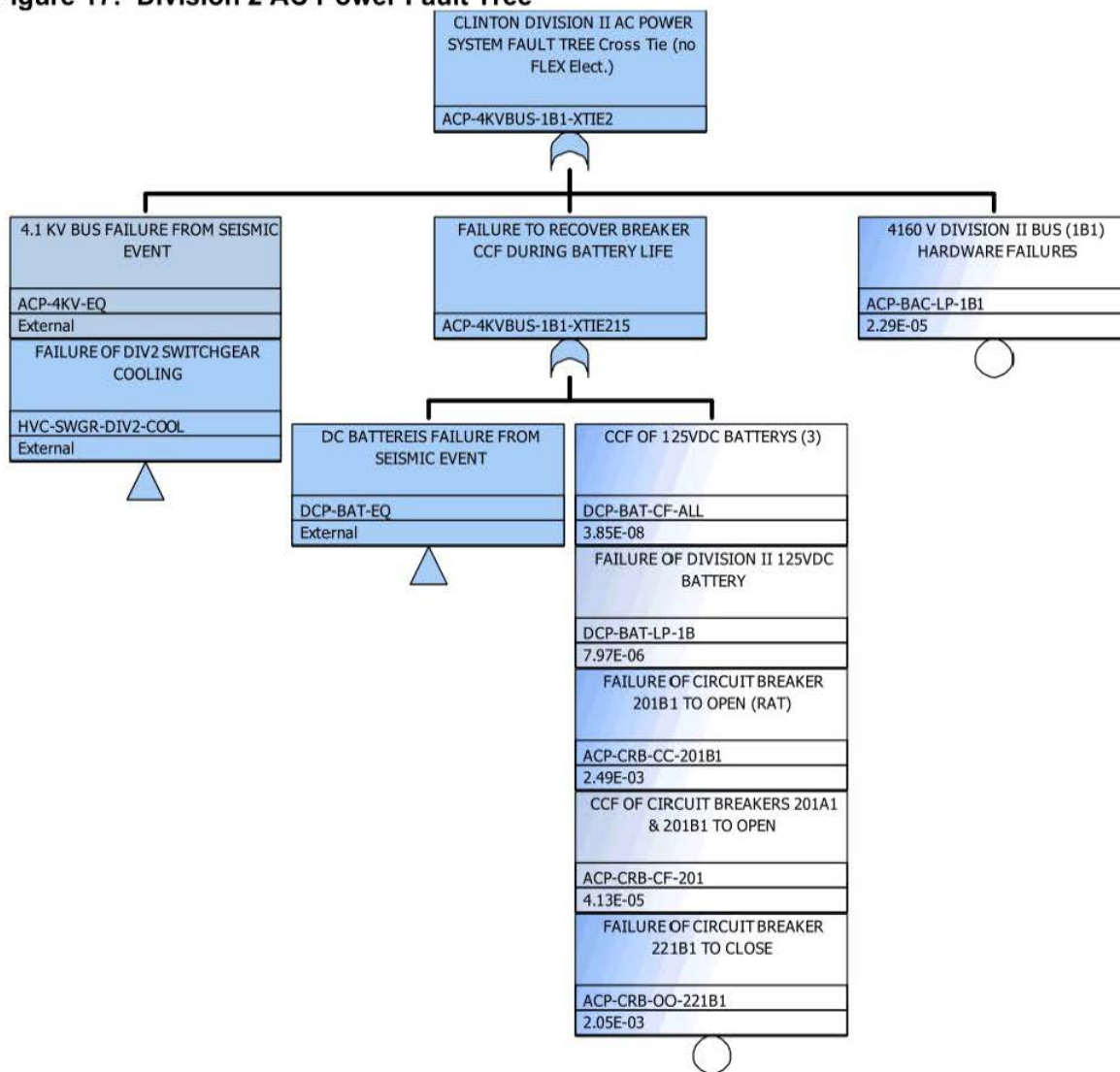

Figure 17: Division 2 AC Power Fault Tree



~~OFFICIAL USE ONLY – SECURITY-RELATED INFORMATION~~

Cut Set Report - 0-SD-			CLINTON SPAR MODEL		
#	Case	Prob/Freq	Total %	Cut Set	Description
Total		4.86E-04	100	Displaying 30 Cut Sets. (27055 Original)	
1	C	1.60E-04	32.98	0-SD-M4L-LOOP : 3-24	
		1.68E-01		SD-M4L-LOOP	Loss of Offsite Power - M4 LATE
		2.02E-01		EPS-XHE-XM-NR01H	OPERATOR FAILS TO RECOVER EDG B IN 1 HOUR due to Start Air Issue
		1.37E-01		OEP-XHE-XL-NR10H	OPERATOR FAILS TO RECOVER OFFSITE POWER IN 10 HOURS
		2.70E-01		SD-XHE-XM-CROSSTIE	Operator Fails to Establish Div. 3 to Div. 2 Electrical Cross Tie
		5.11E-01		SD-XHE-XM-DEPB5B	Operator Fails to setup B5b Equipment for Depressurization (dependent)
		2.50E-01		SD-XHE-XM-FELEC	Operator Fails to Setup and Run FLEX DG and Electrical Distribution
		1.00E+00		TTCU-10	Time to Core Uncovery 10 hours or greater
2	C	8.90E-05	18.32	0-SD-M4L-LOOP : 3-24	
		1.68E-01		SD-M4L-LOOP	Loss of Offsite Power - M4 LATE
		2.02E-01		EPS-XHE-XM-NR01H	OPERATOR FAILS TO RECOVER EDG B IN 1 HOUR due to Start Air Issue
		7.60E-02		SD-XHE-XL-ELAP	Operator fails to recovery electrical distribution system after offsite power recovery
		2.70E-01		SD-XHE-XM-CROSSTIE	Operator Fails to Establish Div. 3 to Div. 2 Electrical Cross Tie
		5.11E-01		SD-XHE-XM-DEPB5B	Operator Fails to setup B5b Equipment for Depressurization (dependent)
		2.50E-01		SD-XHE-XM-FELEC	Operator Fails to Setup and Run FLEX DG and Electrical Distribution
3	C	3.20E-05	6.6	0-SD-M4L-LOOP : 3-24	
		1.68E-01		SD-M4L-LOOP	Loss of Offsite Power - M4 LATE
		2.02E-01		EPS-XHE-XM-NR01H	OPERATOR FAILS TO RECOVER EDG B IN 1 HOUR due to Start Air Issue
		5.00E-02		FLEX-ELEC-CONNECT	FLEX Electrical Connection Fails due to Design or Construction
		1.37E-01		OEP-XHE-XL-NR10H	OPERATOR FAILS TO RECOVER OFFSITE POWER IN 10 HOURS
		2.70E-01		SD-XHE-XM-CROSSTIE	Operator Fails to Establish Div. 3 to Div. 2 Electrical Cross Tie
		5.11E-01		SD-XHE-XM-DEPB5B	Operator Fails to setup B5b Equipment for Depressurization (dependent)
		1.00E+00		TTCU-10	Time to Core Uncovery 10 hours or greater
4	C	3.13E-05	6.45	0-SD-M4L-LOOP : 3-24	
		1.68E-01		SD-M4L-LOOP	Loss of Offsite Power - M4 LATE
		1.00E-01		DEP-B5B	B5b Equipment for Opening SRVs
		2.02E-01		EPS-XHE-XM-NR01H	OPERATOR FAILS TO RECOVER EDG B IN 1 HOUR due to Start Air Issue
		1.37E-01		OEP-XHE-XL-NR10H	OPERATOR FAILS TO RECOVER OFFSITE POWER IN 10 HOURS
		2.70E-01		SD-XHE-XM-CROSSTIE	Operator Fails to Establish Div. 3 to Div. 2 Electrical Cross Tie
		2.50E-01		SD-XHE-XM-FELEC	Operator Fails to Setup and Run FLEX DG and Electrical Distribution
		1.00E+00		TTCU-10	Time to Core Uncovery 10 hours or greater
5	C	2.01E-05	4.14	0-SD-M4L-LOOP : 3-24	
		1.68E-01		SD-M4L-LOOP	Loss of Offsite Power - M4 LATE
		3.39E-02		EPS-DGN-FR-DG1C	DIESEL GENERATOR 1C FAILS TO RUN
		2.02E-01		EPS-XHE-XM-NR01H	OPERATOR FAILS TO RECOVER EDG B IN 1 HOUR due to Start Air Issue
		1.37E-01		OEP-XHE-XL-NR10H	OPERATOR FAILS TO RECOVER OFFSITE POWER IN 10 HOURS
		9.99E-01		OEP-XHE-XX-NR24H1	Convolution Factor for 1FTR-OPR (24H)

~~OFFICIAL USE ONLY – SECURITY-RELATED INFORMATION~~

~~OFFICIAL USE ONLY – SECURITY-RELATED INFORMATION~~

		5.11E-01		SD-XHE-XM-DEPB5B	Operator Fails to setup B5b Equipment for Depressurization (dependent)
		2.50E-01		SD-XHE-XM-FELEC	Operator Fails to Setup and Run FLEX DG and Electrical Distribution
		1.00E+00		TTCU-10	Time to Core Uncovery 10 hours or greater
6	C	1.78E-05	3.66	0-SD-M4L-LOOP : 3-24	
		1.68E-01		SD-M4L-LOOP	Loss of Offsite Power - M4 LATE
		2.02E-01		EPS-XHE-XM-NR01H	OPERATOR FAILS TO RECOVER EDG B IN 1 HOUR due to Start Air Issue
		5.00E-02		FLEX-ELEC-CONNECT	FLEX Electrical Connection Fails due to Design or Construction
		7.60E-02		SD-XHE-XL-ELAP	Operator fails to recovery electrical distribution system after offsite power recovery
		2.70E-01		SD-XHE-XM-CROSSTIE	Operator Fails to Establish Div. 3 to Div. 2 Electrical Cross Tie
		5.11E-01		SD-XHE-XM-DEPB5B	Operator Fails to setup B5b Equipment for Depressurization (dependent)
7	C	1.74E-05	3.58	0-SD-M4L-LOOP : 3-24	
		1.68E-01		SD-M4L-LOOP	Loss of Offsite Power - M4 LATE
		1.00E-01		DEP-B5B	B5b Equipment for Opening SRVs
		2.02E-01		EPS-XHE-XM-NR01H	OPERATOR FAILS TO RECOVER EDG B IN 1 HOUR due to Start Air Issue
		7.60E-02		SD-XHE-XL-ELAP	Operator fails to recovery electrical distribution system after offsite power recovery
		2.70E-01		SD-XHE-XM-CROSSTIE	Operator Fails to Establish Div. 3 to Div. 2 Electrical Cross Tie
		2.50E-01		SD-XHE-XM-FELEC	Operator Fails to Setup and Run FLEX DG and Electrical Distribution
8	C	1.44E-05	2.97	0-SD-M4L-LOOP : 3-24	
		1.68E-01		SD-M4L-LOOP	Loss of Offsite Power - M4 LATE
		1.50E-01		EPS-DGN-FR-FDG1	FLEX Diesel Generator 1 Fails to Run
		1.50E-01		EPS-DGN-FR-FDG2	FLEX Diesel Generator 2 Fails to Run
		2.02E-01		EPS-XHE-XM-NR01H	OPERATOR FAILS TO RECOVER EDG B IN 1 HOUR due to Start Air Issue
		1.37E-01		OEP-XHE-XL-NR10H	OPERATOR FAILS TO RECOVER OFFSITE POWER IN 10 HOURS
		2.70E-01		SD-XHE-XM-CROSSTIE	Operator Fails to Establish Div. 3 to Div. 2 Electrical Cross Tie
		5.11E-01		SD-XHE-XM-DEPB5B	Operator Fails to setup B5b Equipment for Depressurization (dependent)
		1.00E+00		TTCU-10	Time to Core Uncovery 10 hours or greater
9	C	1.19E-05	2.44	0-SD-M4L-LOOP : 3-24	
		1.68E-01		SD-M4L-LOOP	Loss of Offsite Power - M4 LATE
		2.02E-01		EPS-XHE-XM-NR01H	OPERATOR FAILS TO RECOVER EDG B IN 1 HOUR due to Start Air Issue
		1.37E-01		OEP-XHE-XL-NR10H	OPERATOR FAILS TO RECOVER OFFSITE POWER IN 10 HOURS
		5.11E-01		SD-XHE-XM-DEPB5B	Operator Fails to setup B5b Equipment for Depressurization (dependent)
		2.50E-01		SD-XHE-XM-FELEC	Operator Fails to Setup and Run FLEX DG and Electrical Distribution
		1.00E+00		TTCU-10	Time to Core Uncovery 10 hours or greater
		2.00E-02		XTIE-ELEC-CONNECT	Div. 3 to Div. 2 Cross Tie Fails due to Design
10	C	1.12E-05	2.3	0-SD-M4L-LOOP : 3-24	
		1.68E-01		SD-M4L-LOOP	Loss of Offsite Power - M4 LATE
		3.39E-02		EPS-DGN-FR-DG1C	DIESEL GENERATOR 1C FAILS TO RUN
		2.02E-01		EPS-XHE-XM-NR01H	OPERATOR FAILS TO RECOVER EDG B IN 1 HOUR due to Start Air Issue
		7.60E-02		SD-XHE-XL-ELAP	Operator fails to recovery electrical distribution system after offsite power recovery
		5.11E-01		SD-XHE-XM-DEPB5B	Operator Fails to setup B5b Equipment for Depressurization (dependent)
		2.50E-01		SD-XHE-XM-FELEC	Operator Fails to Setup and Run FLEX DG and Electrical Distribution

~~OFFICIAL USE ONLY – SECURITY-RELATED INFORMATION~~

11	C	8.01E-06	1.65	0-SD-M4L-LOOP : 3-24	
		1.68E-01		SD-M4L-LOOP	Loss of Offsite Power - M4 LATE
		1.50E-01		EPS-DGN-FR-FDG1	FLEX Diesel Generator 1 Fails to Run
		1.50E-01		EPS-DGN-FR-FDG2	FLEX Diesel Generator 2 Fails to Run
		2.02E-01		EPS-XHE-XM-NR01H	OPERATOR FAILS TO RECOVER EDG B IN 1 HOUR due to Start Air Issue
		7.60E-02		SD-XHE-XL-ELAP	Operator fails to recovery electrical distribution system after offsite power recovery
		2.70E-01		SD-XHE-XM-CROSSTIE	Operator Fails to Establish Div. 3 to Div. 2 Electrical Cross Tie
		5.11E-01		SD-XHE-XM-DEPB5B	Operator Fails to setup B5b Equipment for Depressurization (dependent)
		6.92E-06		0-SD-M4L-LOOP : 3-24	
		1.68E-01		SD-M4L-LOOP	Loss of Offsite Power - M4 LATE
1.50E-01	EPS-DGN-FR-FDG1	FLEX Diesel Generator 1 Fails to Run			
7.20E-02	EPS-DGN-FS-FDG2	FLEX Diesel Generator 2 Fails to Start			
2.02E-01	EPS-XHE-XM-NR01H	OPERATOR FAILS TO RECOVER EDG B IN 1 HOUR due to Start Air Issue			
1.37E-01	OEP-XHE-XL-NR10H	OPERATOR FAILS TO RECOVER OFFSITE POWER IN 10 HOURS			
2.70E-01	SD-XHE-XM-CROSSTIE	Operator Fails to Establish Div. 3 to Div. 2 Electrical Cross Tie			
5.11E-01	SD-XHE-XM-DEPB5B	Operator Fails to setup B5b Equipment for Depressurization (dependent)			
1.00E+00	TTCU-10	Time to Core Uncovery 10 hours or greater			
12	C	6.92E-06	1.42	0-SD-M4L-LOOP : 3-24	
		1.68E-01		SD-M4L-LOOP	Loss of Offsite Power - M4 LATE
		1.50E-01		EPS-DGN-FR-FDG1	FLEX Diesel Generator 1 Fails to Run
		7.20E-02		EPS-DGN-FS-FDG2	FLEX Diesel Generator 2 Fails to Start
		2.02E-01		EPS-XHE-XM-NR01H	OPERATOR FAILS TO RECOVER EDG B IN 1 HOUR due to Start Air Issue
		1.37E-01		OEP-XHE-XL-NR10H	OPERATOR FAILS TO RECOVER OFFSITE POWER IN 10 HOURS
		2.70E-01		SD-XHE-XM-CROSSTIE	Operator Fails to Establish Div. 3 to Div. 2 Electrical Cross Tie
		5.11E-01		SD-XHE-XM-DEPB5B	Operator Fails to setup B5b Equipment for Depressurization (dependent)
		1.00E+00		TTCU-10	Time to Core Uncovery 10 hours or greater
		6.92E-06		0-SD-M4L-LOOP : 3-24	
1.68E-01	SD-M4L-LOOP	Loss of Offsite Power - M4 LATE			
1.50E-01	EPS-DGN-FR-FDG2	FLEX Diesel Generator 2 Fails to Run			
7.20E-02	EPS-DGN-FS-FDG1	FLEX Diesel Generator 1 Fails to Start			
2.02E-01	EPS-XHE-XM-NR01H	OPERATOR FAILS TO RECOVER EDG B IN 1 HOUR due to Start Air Issue			
1.37E-01	OEP-XHE-XL-NR10H	OPERATOR FAILS TO RECOVER OFFSITE POWER IN 10 HOURS			
2.70E-01	SD-XHE-XM-CROSSTIE	Operator Fails to Establish Div. 3 to Div. 2 Electrical Cross Tie			
5.11E-01	SD-XHE-XM-DEPB5B	Operator Fails to setup B5b Equipment for Depressurization (dependent)			
1.00E+00	TTCU-10	Time to Core Uncovery 10 hours or greater			
13	C	6.59E-06	1.36	0-SD-M4L-LOOP : 3-24	
		1.68E-01		SD-M4L-LOOP	Loss of Offsite Power - M4 LATE
		2.02E-01		EPS-XHE-XM-NR01H	OPERATOR FAILS TO RECOVER EDG B IN 1 HOUR due to Start Air Issue
		7.60E-02		SD-XHE-XL-ELAP	Operator fails to recovery electrical distribution system after offsite power recovery
		5.11E-01		SD-XHE-XM-DEPB5B	Operator Fails to setup B5b Equipment for Depressurization (dependent)
		2.50E-01		SD-XHE-XM-FELEC	Operator Fails to Setup and Run FLEX DG and Electrical Distribution
		2.00E-02		XTIE-ELEC-CONNECT	Div. 3 to Div. 2 Cross Tie Fails due to Design
		6.27E-06		0-SD-M4L-LOOP : 3-24	
		1.68E-01		SD-M4L-LOOP	Loss of Offsite Power - M4 LATE
		1.00E-01		DEP-B5B	B5b Equipment for Opening SRVs
2.02E-01	EPS-XHE-XM-NR01H	OPERATOR FAILS TO RECOVER EDG B IN 1 HOUR due to Start Air Issue			
5.00E-02	FLEX-ELEC-CONNECT	FLEX Electrical Connection Fails due to Design or Construction			
1.37E-01	OEP-XHE-XL-NR10H	OPERATOR FAILS TO RECOVER OFFSITE POWER IN 10 HOURS			
2.70E-01	SD-XHE-XM-CROSSTIE	Operator Fails to Establish Div. 3 to Div. 2 Electrical Cross Tie			
1.00E+00	TTCU-10	Time to Core Uncovery 10 hours or greater			
14	C	6.27E-06	1.29	0-SD-M4L-LOOP : 3-24	
		1.68E-01		SD-M4L-LOOP	Loss of Offsite Power - M4 LATE
		1.00E-01		DEP-B5B	B5b Equipment for Opening SRVs
		2.02E-01		EPS-XHE-XM-NR01H	OPERATOR FAILS TO RECOVER EDG B IN 1 HOUR due to Start Air Issue
		5.00E-02		FLEX-ELEC-CONNECT	FLEX Electrical Connection Fails due to Design or Construction
		1.37E-01		OEP-XHE-XL-NR10H	OPERATOR FAILS TO RECOVER OFFSITE POWER IN 10 HOURS
		2.70E-01		SD-XHE-XM-CROSSTIE	Operator Fails to Establish Div. 3 to Div. 2 Electrical Cross Tie
		1.00E+00		TTCU-10	Time to Core Uncovery 10 hours or greater
		6.27E-06		0-SD-M4L-LOOP : 3-24	
		1.68E-01		SD-M4L-LOOP	Loss of Offsite Power - M4 LATE
1.00E-01	DEP-B5B	B5b Equipment for Opening SRVs			
2.02E-01	EPS-XHE-XM-NR01H	OPERATOR FAILS TO RECOVER EDG B IN 1 HOUR due to Start Air Issue			
5.00E-02	FLEX-ELEC-CONNECT	FLEX Electrical Connection Fails due to Design or Construction			
1.37E-01	OEP-XHE-XL-NR10H	OPERATOR FAILS TO RECOVER OFFSITE POWER IN 10 HOURS			
2.70E-01	SD-XHE-XM-CROSSTIE	Operator Fails to Establish Div. 3 to Div. 2 Electrical Cross Tie			
1.00E+00	TTCU-10	Time to Core Uncovery 10 hours or greater			
15	C	6.27E-06	1.29	0-SD-M4L-LOOP : 3-24	
		1.68E-01		SD-M4L-LOOP	Loss of Offsite Power - M4 LATE
		1.00E-01		DEP-B5B	B5b Equipment for Opening SRVs
		2.02E-01		EPS-XHE-XM-NR01H	OPERATOR FAILS TO RECOVER EDG B IN 1 HOUR due to Start Air Issue
		5.00E-02		FLEX-ELEC-CONNECT	FLEX Electrical Connection Fails due to Design or Construction
		1.37E-01		OEP-XHE-XL-NR10H	OPERATOR FAILS TO RECOVER OFFSITE POWER IN 10 HOURS
		2.70E-01		SD-XHE-XM-CROSSTIE	Operator Fails to Establish Div. 3 to Div. 2 Electrical Cross Tie
		1.00E+00		TTCU-10	Time to Core Uncovery 10 hours or greater
		6.27E-06		0-SD-M4L-LOOP : 3-24	
		1.68E-01		SD-M4L-LOOP	Loss of Offsite Power - M4 LATE
1.00E-01	DEP-B5B	B5b Equipment for Opening SRVs			
2.02E-01	EPS-XHE-XM-NR01H	OPERATOR FAILS TO RECOVER EDG B IN 1 HOUR due to Start Air Issue			
5.00E-02	FLEX-ELEC-CONNECT	FLEX Electrical Connection Fails due to Design or Construction			
1.37E-01	OEP-XHE-XL-NR10H	OPERATOR FAILS TO RECOVER OFFSITE POWER IN 10 HOURS			
2.70E-01	SD-XHE-XM-CROSSTIE	Operator Fails to Establish Div. 3 to Div. 2 Electrical Cross Tie			
1.00E+00	TTCU-10	Time to Core Uncovery 10 hours or greater			

16	C	4.80E-06	0.99	0-SD-M4L-LOOP : 3-24	
		1.68E-01		SD-M4L-LOOP	Loss of Offsite Power - M4 LATE
		1.50E-01		EPS-DGN-FR-FDG1	FLEX Diesel Generator 1 Fails to Run
		5.00E-02		EPS-DGN-XR-FDG	FLEX Diesel 2 (portable) Fails due to Improper Transport or Setup
		2.02E-01		EPS-XHE-XM-NR01H	OPERATOR FAILS TO RECOVER EDG B IN 1 HOUR due to Start Air Issue
		1.37E-01		OEP-XHE-XL-NR10H	OPERATOR FAILS TO RECOVER OFFSITE POWER IN 10 HOURS
		2.70E-01		SD-XHE-XM-CROSSTIE	Operator Fails to Establish Div. 3 to Div. 2 Electrical Cross Tie
		5.11E-01		SD-XHE-XM-DEPB5B	Operator Fails to setup B5b Equipment for Depressurization (dependent)
		1.00E+00		TTCU-10	Time to Core Uncovery 10 hours or greater
17	C	4.02E-06	0.83	0-SD-M4L-LOOP : 3-24	
		1.68E-01		SD-M4L-LOOP	Loss of Offsite Power - M4 LATE
		3.39E-02		EPS-DGN-FR-DG1C	DIESEL GENERATOR 1C FAILS TO RUN
		2.02E-01		EPS-XHE-XM-NR01H	OPERATOR FAILS TO RECOVER EDG B IN 1 HOUR due to Start Air Issue
		5.00E-02		FLEX-ELEC-CONNECT	FLEX Electrical Connection Fails due to Design or Construction
		1.37E-01		OEP-XHE-XL-NR10H	OPERATOR FAILS TO RECOVER OFFSITE POWER IN 10 HOURS
		9.99E-01		OEP-XHE-XX-NR24H1	Convolution Factor for 1FTR-OPR (24H-)
		5.11E-01		SD-XHE-XM-DEPB5B	Operator Fails to setup B5b Equipment for Depressurization (dependent)
		1.00E+00		TTCU-10	Time to Core Uncovery 10 hours or greater
18	C	3.93E-06	0.81	0-SD-M4L-LOOP : 3-24	
		1.68E-01		SD-M4L-LOOP	Loss of Offsite Power - M4 LATE
		1.00E-01		DEP-B5B	B5b Equipment for Opening SRVs
		3.39E-02		EPS-DGN-FR-DG1C	DIESEL GENERATOR 1C FAILS TO RUN
		2.02E-01		EPS-XHE-XM-NR01H	OPERATOR FAILS TO RECOVER EDG B IN 1 HOUR due to Start Air Issue
		1.37E-01		OEP-XHE-XL-NR10H	OPERATOR FAILS TO RECOVER OFFSITE POWER IN 10 HOURS
		9.99E-01		OEP-XHE-XX-NR24H1	Convolution Factor for 1FTR-OPR (24H-)
		2.50E-01		SD-XHE-XM-FELEC	Operator Fails to Setup and Run FLEX DG and Electrical Distribution
		1.00E+00		TTCU-10	Time to Core Uncovery 10 hours or greater
19	C	3.84E-06	0.79	0-SD-M4L-LOOP : 3-24	
		1.68E-01		SD-M4L-LOOP	Loss of Offsite Power - M4 LATE
		1.50E-01		EPS-DGN-FR-FDG2	FLEX Diesel Generator 2 Fails to Run
		7.20E-02		EPS-DGN-FS-FDG1	FLEX Diesel Generator 1 Fails to Start
		2.02E-01		EPS-XHE-XM-NR01H	OPERATOR FAILS TO RECOVER EDG B IN 1 HOUR due to Start Air Issue
		7.60E-02		SD-XHE-XL-ELAP	Operator fails to recovery electrical distribution system after offsite power recovery
		2.70E-01		SD-XHE-XM-CROSSTIE	Operator Fails to Establish Div. 3 to Div. 2 Electrical Cross Tie
		5.11E-01		SD-XHE-XM-DEPB5B	Operator Fails to setup B5b Equipment for Depressurization (dependent)
		1.00E+00		TTCU-10	Time to Core Uncovery 10 hours or greater
20	C	3.84E-06	0.79	0-SD-M4L-LOOP : 3-24	
		1.68E-01		SD-M4L-LOOP	Loss of Offsite Power - M4 LATE
		1.50E-01		EPS-DGN-FR-FDG1	FLEX Diesel Generator 1 Fails to Run
		7.20E-02		EPS-DGN-FS-FDG2	FLEX Diesel Generator 2 Fails to Start
		2.02E-01		EPS-XHE-XM-NR01H	OPERATOR FAILS TO RECOVER EDG B IN 1 HOUR due to Start Air Issue
		7.60E-02		SD-XHE-XL-ELAP	Operator fails to recovery electrical distribution system after offsite power recovery

~~OFFICIAL USE ONLY – SECURITY-RELATED INFORMATION~~

		2.70E-01		SD-XHE-XM-CROSSTIE	Operator Fails to Establish Div. 3 to Div. 2 Electrical Cross Tie
		5.11E-01		SD-XHE-XM-DEPB5B	Operator Fails to setup B5b Equipment for Depressurization (dependent)
21	C	3.48E-06	0.72	0-SD-M4L-LOOP : 3-24	
		1.68E-01		SD-M4L-LOOP	Loss of Offsite Power - M4 LATE
		1.00E-01		DEP-B5B	B5b Equipment for Opening SRVs
		2.02E-01		EPS-XHE-XM-NR01H	OPERATOR FAILS TO RECOVER EDG B IN 1 HOUR due to Start Air Issue
		5.00E-02		FLEX-ELEC-CONNECT	FLEX Electrical Connection Fails due to Design or Construction
		7.60E-02		SD-XHE-XL-ELAP	Operator fails to recovery electrical distribution system after offsite power recovery
		2.70E-01		SD-XHE-XM-CROSSTIE	Operator Fails to Establish Div. 3 to Div. 2 Electrical Cross Tie
22	C	3.32E-06	0.68	0-SD-M4L-LOOP : 3-24	
		1.68E-01		SD-M4L-LOOP	Loss of Offsite Power - M4 LATE
		7.20E-02		EPS-DGN-FS-FDG1	FLEX Diesel Generator 1 Fails to Start
		7.20E-02		EPS-DGN-FS-FDG2	FLEX Diesel Generator 2 Fails to Start
		2.02E-01		EPS-XHE-XM-NR01H	OPERATOR FAILS TO RECOVER EDG B IN 1 HOUR due to Start Air Issue
		1.37E-01		OEP-XHE-XL-NR10H	OPERATOR FAILS TO RECOVER OFFSITE POWER IN 10 HOURS
		2.70E-01		SD-XHE-XM-CROSSTIE	Operator Fails to Establish Div. 3 to Div. 2 Electrical Cross Tie
		5.11E-01		SD-XHE-XM-DEPB5B	Operator Fails to setup B5b Equipment for Depressurization (dependent)
		1.00E+00		TTCU-10	Time to Core Uncovery 10 hours or greater
23	C	2.82E-06	0.58	0-SD-M4L-LOOP : 3-24	
		1.68E-01		SD-M4L-LOOP	Loss of Offsite Power - M4 LATE
		1.00E-01		DEP-B5B	B5b Equipment for Opening SRVs
		1.50E-01		EPS-DGN-FR-FDG1	FLEX Diesel Generator 1 Fails to Run
		1.50E-01		EPS-DGN-FR-FDG2	FLEX Diesel Generator 2 Fails to Run
		2.02E-01		EPS-XHE-XM-NR01H	OPERATOR FAILS TO RECOVER EDG B IN 1 HOUR due to Start Air Issue
		1.37E-01		OEP-XHE-XL-NR10H	OPERATOR FAILS TO RECOVER OFFSITE POWER IN 10 HOURS
		2.70E-01		SD-XHE-XM-CROSSTIE	Operator Fails to Establish Div. 3 to Div. 2 Electrical Cross Tie
		1.00E+00		TTCU-10	Time to Core Uncovery 10 hours or greater
24	C	2.67E-06	0.55	0-SD-M4L-LOOP : 3-24	
		1.68E-01		SD-M4L-LOOP	Loss of Offsite Power - M4 LATE
		1.50E-01		EPS-DGN-FR-FDG1	FLEX Diesel Generator 1 Fails to Run
		5.00E-02		EPS-DGN-XR-FDG	FLEX Diesel 2 (portable) Fails due to Improper Transport or Setup
		2.02E-01		EPS-XHE-XM-NR01H	OPERATOR FAILS TO RECOVER EDG B IN 1 HOUR due to Start Air Issue
		7.60E-02		SD-XHE-XL-ELAP	Operator fails to recovery electrical distribution system after offsite power recovery
		2.70E-01		SD-XHE-XM-CROSSTIE	Operator Fails to Establish Div. 3 to Div. 2 Electrical Cross Tie
		5.11E-01		SD-XHE-XM-DEPB5B	Operator Fails to setup B5b Equipment for Depressurization (dependent)
25	C	2.37E-06	0.49	0-SD-M4L-LOOP : 3-24	
		1.68E-01		SD-M4L-LOOP	Loss of Offsite Power - M4 LATE
		2.02E-01		EPS-XHE-XM-NR01H	OPERATOR FAILS TO RECOVER EDG B IN 1 HOUR due to Start Air Issue
		5.00E-02		FLEX-ELEC-CONNECT	FLEX Electrical Connection Fails due to Design or Construction
		1.37E-01		OEP-XHE-XL-NR10H	OPERATOR FAILS TO RECOVER OFFSITE POWER IN 10 HOURS
		5.11E-01		SD-XHE-XM-DEPB5B	Operator Fails to setup B5b Equipment for Depressurization (dependent)

~~OFFICIAL USE ONLY – SECURITY-RELATED INFORMATION~~

~~OFFICIAL USE ONLY – SECURITY-RELATED INFORMATION~~

		1.00E+00		TTCU-10	Time to Core Uncovery 10 hours or greater
		2.00E-02		XTIE-ELEC-CONNECT	Div. 3 to Div. 2 Cross Tie Fails due to Design
26	C	2.32E-06	0.48	0-SD-M4L-LOOP : 3-24	
		1.68E-01		SD-M4L-LOOP	Loss of Offsite Power - M4 LATE
		1.00E-01		DEP-B5B	B5b Equipment for Opening SRVs
		2.02E-01		EPS-XHE-XM-NR01H	OPERATOR FAILS TO RECOVER EDG B IN 1 HOUR due to Start Air Issue
		1.37E-01		OEP-XHE-XL-NR10H	OPERATOR FAILS TO RECOVER OFFSITE POWER IN 10 HOURS
		2.50E-01		SD-XHE-XM-FELEC	Operator Fails to Setup and Run FLEX DG and Electrical Distribution
		1.00E+00		TTCU-10	Time to Core Uncovery 10 hours or greater
		2.00E-02		XTIE-ELEC-CONNECT	Div. 3 to Div. 2 Cross Tie Fails due to Design
27	C	2.31E-06	0.47	0-SD-M4L-LOOP : 3-24	
		1.68E-01		SD-M4L-LOOP	Loss of Offsite Power - M4 LATE
		7.20E-02		EPS-DGN-FS-FDG1	FLEX Diesel Generator 1 Fails to Start
		5.00E-02		EPS-DGN-XR-FDG	FLEX Diesel 2 (portable) Fails due to Improper Transport or Setup
		2.02E-01		EPS-XHE-XM-NR01H	OPERATOR FAILS TO RECOVER EDG B IN 1 HOUR due to Start Air Issue
		1.37E-01		OEP-XHE-XL-NR10H	OPERATOR FAILS TO RECOVER OFFSITE POWER IN 10 HOURS
		2.70E-01		SD-XHE-XM-CROSSTIE	Operator Fails to Establish Div. 3 to Div. 2 Electrical Cross Tie
		5.11E-01		SD-XHE-XM-DEPB5B	Operator Fails to setup B5b Equipment for Depressurization (dependent)
		1.00E+00		TTCU-10	Time to Core Uncovery 10 hours or greater
28	C	2.23E-06	0.46	0-SD-M4L-LOOP : 3-24	
		1.68E-01		SD-M4L-LOOP	Loss of Offsite Power - M4 LATE
		3.39E-02		EPS-DGN-FR-DG1C	DIESEL GENERATOR 1C FAILS TO RUN
		2.02E-01		EPS-XHE-XM-NR01H	OPERATOR FAILS TO RECOVER EDG B IN 1 HOUR due to Start Air Issue
		5.00E-02		FLEX-ELEC-CONNECT	FLEX Electrical Connection Fails due to Design or Construction
		7.60E-02		SD-XHE-XL-ELAP	Operator fails to recovery electrical distribution system after offsite power recovery
		5.11E-01		SD-XHE-XM-DEPB5B	Operator Fails to setup B5b Equipment for Depressurization (dependent)
29	C	2.20E-06	0.45	0-SD-M4L-LOOP : 3-24	
		1.68E-01		SD-M4L-LOOP	Loss of Offsite Power - M4 LATE
		3.70E-03		EPS-DGN-LR-DG1C	DIESEL GENERATOR 1C FAILS TO LOAD RUN
		2.02E-01		EPS-XHE-XM-NR01H	OPERATOR FAILS TO RECOVER EDG B IN 1 HOUR due to Start Air Issue
		1.37E-01		OEP-XHE-XL-NR10H	OPERATOR FAILS TO RECOVER OFFSITE POWER IN 10 HOURS
		5.11E-01		SD-XHE-XM-DEPB5B	Operator Fails to setup B5b Equipment for Depressurization (dependent)
		2.50E-01		SD-XHE-XM-FELEC	Operator Fails to Setup and Run FLEX DG and Electrical Distribution
		1.00E+00		TTCU-10	Time to Core Uncovery 10 hours or greater
30	C	2.19E-06	0.45	0-SD-M4L-LOOP : 3-24	
		1.68E-01		SD-M4L-LOOP	Loss of Offsite Power - M4 LATE
		1.00E-01		DEP-B5B	B5b Equipment for Opening SRVs
		3.39E-02		EPS-DGN-FR-DG1C	DIESEL GENERATOR 1C FAILS TO RUN
		2.02E-01		EPS-XHE-XM-NR01H	OPERATOR FAILS TO RECOVER EDG B IN 1 HOUR due to Start Air Issue
		7.60E-02		SD-XHE-XL-ELAP	Operator fails to recovery electrical distribution system after offsite power recovery
		2.50E-01		SD-XHE-XM-FELEC	Operator Fails to Setup and Run FLEX DG and Electrical Distribution

~~OFFICIAL USE ONLY – SECURITY-RELATED INFORMATION~~