

SALEM NUCLEAR GENERATING STATION

OFFSITE DOSE CALCULATION MANUAL

Revision 11 March 1998

REVISION SUMMARY

Section 1.2.1 - Removed note referencing inclusion of most recent composite of non-gamma emitters in setpoint calculation

Section 1.2.2 - Added discussion of basis for alarm setpoints during batch releases

Safety Factor used in liquid effluent alarm setpoint calculations specified at 0.75

Incorporated changes in gaseous rad monitor designation from R41C to R41D as per DCPs 1EC-3244 and 2EC-3212

Table E-1 deleted reference to TLD location changes noted in ODCM Rev. 10; changed control air sampler location from Maplewood to Delaware location.

Prepared by:

J. Drueck

Date:

3/14/98

Reviewed by:

Paul A. [Signature]

Date:

3/14/98

Approved by:

James Clancy

Date:

3/14/98

Approval

SORC Chairman:

J. [Signature]

Date:

3/14/98

Mtg. #

98-040

SALEM NUCLEAR GENERATING STATION
OFFSITE DOSE CALCULATION MANUAL
Table of Contents

Introduction.....	1
1.0 Liquid Effluents	
1.1 Radiation Monitoring Instrumentation and Controls...	2
1.2 Liquid Effluent Monitor Setpoint Determination.....	3
1.2.1 Liquid Effluent Monitors (Radwaste, Steam Generator Blowdown and Service Water).....	4
1.2.2 Conservative Default Values.....	5
1.3 Liquid Effluent Concentration Limits - 10 CFR 20....	6
1.4 Liquid Effluent Dose Calculations - 10 CFR 50.....	8
1.4.1 Member of the Public Dose - Liquid Effluents.....	8
1.4.2 Simplified Liquid Effluent Dose Calculation.....	10
1.5 Secondary Side Radioactive Liquid Effluents - Dose Calculations During Primary to Secondary Leakage...	11
1.6 Liquid Effluent Dose Projection	12
2.0 Gaseous Effluents	
2.1 Radiation Monitoring Instrumentation and Controls .	13
2.2 Gaseous Effluent Monitor Setpoint Determination ...	14
2.2.1 Containment and Plant Monitor	14
2.2.2 Conservative Default Values.....	15
2.3 Gaseous Effluent Instantaneous Dose Rate Calculations - 10 CFR 20.....	16
2.3.1 Site Boundary Dose Rate - Noble Gases.....	16
2.3.2 Site Boundary Dose Rate - Radioiodine and Particulates	18
2.4 Noble Gas Effluent Dose Calculations - 10 CFR 50... 19	
2.4.1 UNRESTRICTED AREA Dose - Noble Gases	19
2.4.2 Simplified Dose Calculation for Noble Gases.....	20
2.5 Radioiodine and Particulate Dose Calculations - 10 CFR 50	21
2.5.1 UNRESTRICTED AREA Dose - Radioiodine and Particulates	21
2.5.2 Simplified Dose Calculation for Radioiodines and Particulates	22
2.6 Secondary Side Radioactive Gaseous Effluents and Dose Calculations	23
2.7 Gaseous Effluent Dose Projection	25
3.0 Special Dose Analyses	
3.1 Doses Due To Activities Inside the SITE BOUNDARY...	26
3.2 Doses to MEMBERS OF THE PUBLIC - 40 CFR 190.....	26
3.2.1 Effluent Dose Calculations	27
3.2.2 Direct Exposure Determination	27

Table of Contents - Continued

4.0	Radiological Environmental Monitoring Program	28
4.1	Sampling Program	28
4.2	Interlaboratory Comparison Program	28

	Radwaste System Flowpaths and Description	29
--	---	----

Tables

1-1	Parameters for Liquid Alarm Setpoint Determination	
	- Unit 1	32
1-2	Parameters for Liquid Alarm Setpoint Determination	
	- Unit 2	33
1-3	Site Related Ingestion Dose Commitment	
	Factors, A_{10}	34-35
1-4	Bioaccumulation Factors (Bfi)	36
2-1	Dose Factors for Noble Gases	39
2-2	Parameters for Gaseous Alarm Setpoint Determinations	
	- Unit 1	40
2-3	Parameters for Gaseous Alarm Setpoint Determinations	
	- Unit 2	41
2-4	Controlling Locations, Pathways and Atmospheric	
	Dispersion for Dose Calculations	41
2-5	Pathway Dose Parameters - Atmospheric Releases	43-54
A-1	Calculation of Effective MPC - Unit 1	A-6
A-2	Calculation of Effective MPC - Unit 2	A-7
B-1	Adult Dose Contributions Fish and Drinking Water	
	Pathways Unit 1	B-5
B-2	Adult Dose Contributions Fish and Drinking Water	
	Pathways Unit 2	B-5
C-1	Effective Dose Factors	C-4
D-1	Infant Dose Contribution Fraction of Dose	D-5
D-2	Fraction of Dose Contribution by Pathway	D-5
E-1	Environmental Sampling Locations	E-3

Appendices

Appendix A	- Evaluation of Conservative, Default MPC	
	Value for Liquid Effluents	A-1
Appendix B	- Technical Basis for Effective Dose Factors -	
	Liquid Radioactive Effluents	B-1
Appendix C	- Technical Basis for Effective Dose Factors -	
	Gaseous Radioactive Effluents	C-1
Appendix D	- Technical Basis for Effective Dose -	
	Parameters - Gaseous Effluents	D-1
Appendix E	- Radiological Environmental Monitoring	
	Program - Sample Type, Location	
	and Analysis	E-1

SALEM NUCLEAR GENERATING STATION
OFFSITE DOSE CALCULATION MANUAL

Introduction

The Salem Offsite Dose Calculation Manual (ODCM) describes the methodology and parameters used in:

- 1) the calculation of radioactive liquid and gaseous effluent monitoring instrumentation alarm/trip setpoints; and
- 2) the calculation of radioactive liquid and gaseous concentrations, dose rates and cumulative quarterly and yearly doses.

The methodology stated in this manual is acceptable for use in demonstrating compliance with 10 CFR 20.106, 10 CFR 50, Appendix I and 40 CFR 190. More conservative calculation methods and/or conditions (e.g., location and/or exposure pathways) expected to yield higher computed doses than appropriate for the maximally exposed person may be assumed in the dose evaluations.

The ODCM will be maintained at the station for use as a reference guide and training document of accepted methodologies and calculations. Changes will be made to the ODCM calculation methodologies and parameters as is deemed necessary to ensure reasonable conservatism in keeping with the principles of 10 CFR 50.36a and Appendix I for demonstrating radioactive effluents are ALARA.

NOTE: As used throughout this document, excluding acronyms, words appearing all capitalized denote the application of definitions as used in the Salem Technical Specifications.

1.0 Liquid Effluents

1.1 Radiation Monitoring Instrumentation and Controls

The liquid effluent monitoring instrumentation and controls at Salem for controlling and monitoring normal radioactive material releases in accordance with the Salem Radiological Effluent Technical Specifications are summarized as follows:

- 1) Alarm (and Automatic Termination) - 1-R18 (Unit 1) and 2-R18 (Unit 2) provide the alarm and automatic termination of liquid radioactive material releases as required by Technical Specification 3.3.3.8.

1-R19 A,B,C, and D provide the alarm and isolation function for the Unit 1 steam generator blowdown lines. 2-R19 A,B,C and D provide this function for Unit 2.

- 2) Alarm (only) - The alarm functions for the Service Water System are provided by the radiation monitors on the Containment Fan Cooler discharges (1-R 13 A,B,C,D and E for Unit 1 and 2-R 13 A,B, and C for Unit 2).

Releases from the secondary system are routed through the Chemical Waste Basin where the effluent is monitored (with an alarm function) by R37 prior to release to the environment.

Liquid radioactive waste flow diagrams with the applicable, associated radiation monitoring instrumentation and controls are presented as Figures 1-1 and 1-2 for Units 1 and 2, respectively.

1.2 Liquid Effluent Monitor Setpoint Determination

Per the requirements of Technical Specification 3.3.3.8, alarm setpoints shall be established for the liquid effluent monitoring instrumentation to ensure that the release concentration limits of Specification 3.11.1.1 are met (i.e., the concentration of radioactive material released in liquid effluents to UNRESTRICTED AREAS shall be limited to the concentrations specified in 10 CFR 20, Appendix B, Table II, Column 2, for radionuclides and $2.0E-04$ uCi/ml for dissolved or entrained noble gases).

The following equation* must be satisfied to meet the liquid effluent restrictions:

$$c \leq \frac{C (F+f)}{f} \quad (1.1)$$

where:

- C = the effluent concentration limit of Technical Specification (3.11.1.1) implementing the 10 CFR 20 MPC for the site, in uCi/ml
- c = the setpoint, in uCi/ml, of the radioactivity monitor measuring the radioactivity concentration in the effluent line prior to dilution and subsequent release; the setpoint, represents a value which, if exceeded, would result in concentrations exceeding the limits of 10 CFR 20 in the UNRESTRICTED AREA
- f = the flow rate at the radiation monitor location, in volume per unit time, but in the same units as F, below
- F = the dilution water flow rate as measured prior to the release point. in volume per unit time

[Note that if no dilution is provided, $c \leq C$. Also, note that when (F) is large compared to (f), then $(F + f) = F$.]

* Adapted from NUREG-0133

1.2.1 Liquid Effluent Monitors (Radwaste, Steam Generator
Blowdown, Chemical Waste Basin and Service Water.

The setpoints for the liquid effluent monitors at the Salem Nuclear Generating Station are determined by the following equations:

$$SP \leq \frac{MPCe * SEN * CW * SF}{RR} + bkg \quad (1.2)$$

with:

$$MPCe = \frac{\sum Ci}{\sum \frac{Ci}{MPC_i}} \quad (1.3)$$

where:

- SP = alarm setpoint corresponding to the maximum allowable release rate (cpm)
- MPCe = an effective MPC value for the mixture of radionuclides in the effluent stream (uCi/ml)
- Ci = the concentration of radionuclide i in the undiluted liquid effluents (uCi/ml)*
- MPC_i = the MPC value corresponding to radionuclide i from 10 CFR 20, Appendix B, Table II, Column 2 (uCi/ml)
- SEN = the sensitivity value to which the monitor is calibrated (cpm per uCi/ml)
- CW = the circulating water flow rate (dilution water flow) at the time of release (gal/min)
- RR = the liquid effluent release rate (gal/min)
- bkg = the background of the monitor (cpm)
- SF = Safety factor to account for non-gamma emitting nuclides in default setpoint calculations.

The radioactivity monitor setpoint equation (1.2) remains valid during outages when the circulating water dilution is potentially at its lowest value. Reduction of the waste stream flow (RR) may be necessary during these periods to meet the discharge criteria.

However, in order to maximize the available plant discharge dilution and thereby minimize the potential offsite doses, releases from either Unit-1 or Unit-2 may be routed to either the Unit-1 or Unit-2 Circulating Water System discharge. This routing is possible via interconnections between the Service Water Systems (see Pages 29 and 30).

Procedural restrictions prevent simultaneous releases from either a single unit or both units into a single Circulating Water System discharge.

1.2.2 Conservative Default Values.

Conservative alarm setpoints may be determined through the use of default parameters. Tables 1-1 and 1-2 summarize all current default values in use for Salem Unit-1 and Unit-2, respectively. They are based upon the following:

- a) substitution of the effective MPC value with a default value of $6.05E-06$ uCi/ml (Unit 1) and $4.81E-06$ uCi/ml (Unit 2). (refer to Appendix A for justification);
- b) for additional conservatism*, substitution of the I-131 MPC value of $3E-07$ uCi/ml for the R19 Steam Generator Blowdown Monitors, the R-37 Chemical Waste Basin monitor and the R-13 Service Water Monitors.
- c) substitutions of the operational circulating water flow with the lowest flow, in gal/min; and,
- d) substitutions of the effluent release rate with the highest allowed rate, in gal/min.
- e) substitution of a safety factor of 0.75 to account for non-gamma emitting nuclides.

For batch liquid releases a fixed alarm setpoint is established for the 1,2 R18 monitors and the release rate is controlled to ensure the inequality of equation 1.1 is maintained. With this approach, values selected for the parameters in the setpoint calculation (e.g., Table 1-1 and Table 1-2) should be any set of

reasonable values that provide a setpoint value significantly above anticipated monitor response, plus background, so as not to yield spurious alarms. The release rate is controlled to ensure compliance with the requirements of Technical Specification 3.3.3.8.

Calculations, as performed by Engineering, to establish the actual fixed setpoints for use in the plant, incorporate uncertainties and instrument drift. These factors will cause the actual installed instrument setpoint to be at a lower (conservative) value. However, for batch releases, when the rate is controlled, these uncertainties and drift should not be included in the evaluation of acceptable release rate, since this could cause a non-conservative correction, i.e., a higher allowable release rate. Therefore, for 1,2 R18 monitors, the setpoint value used for calculating the allowable release rate should be that value prior to correction for uncertainty and drift.

- * Based upon the potential for I-131 to be present in the secondary and service water systems, the use of the default effective MPC value as derived in Appendix A may be non-conservative for the 1, 2 R-19 SGBD monitors, the R-37 Chemical Waste Basin Monitor and the R-13 Service Water Monitors.

1.3 Liquid Effluent Concentration Limits - 10 CFR 20

Technical Specification 3.11.1.1 limits the concentration of radioactive material in liquid effluents (after dilution in the Circulating Water System) to less than the concentrations as specified in 10 CFR 20, Appendix B, Table II, Column 2 for radionuclides other than noble gases. Noble gases are limited to a diluted concentration of 2.0E-04 uCi/ml.

Release rates are controlled and radiation monitor alarm setpoints are established as addressed above to ensure that these concentration limits are not exceeded. However, in the event any liquid release results in an alarm setpoint being exceeded, an evaluation of compliance with the concentration limits of Technical Specification 3.11.1.1 may be performed using the following equation:

$$\sum \frac{C_1}{MPC_1} * \frac{RR}{CW + RR} \leq 1 \quad (1.4)$$

where:

- C_1 = actual concentration of radionuclide i as measured in the undiluted liquid effluent (uCi/ml)
- MPC = the MPC value corresponding to radionuclide i from 10 CFR 20, Appendix B, Table II, Column 2 (uCi/ml)
= 2E-04 uCi/ml for dissolved or entrained noble gases
- RR = the actual liquid effluent release rate (gal/min)
- CW = the actual circulating water flow rate (dilution water flow) at the time of the release (gal/min)

1.4 Liquid Effluent Dose Calculation - 10 CFR 501.4.1 MEMBER OF THE PUBLIC Dose - Liquid Effluents.

Technical Specification 3.11.1.2 limits the dose or dose commitment to MEMBERS OF THE PUBLIC from radioactive materials in liquid effluents from each unit of the Salem Nuclear Generating Station to:

- during any calendar quarter;
 - < 1.5 mrem to total body per unit
 - < 5.0 mrem to any organ per unit
- during any calendar year;
 - < 3.0 mrem to total body per unit
 - < 10.0 mrem to any organ per unit.

Per the surveillance requirements of Technical Specification 4.11.1.2, the following calculational methods shall be used for determining the dose or dose commitment due to the liquid radioactive effluents from Salem.

$$D_o = \frac{1.67E-02 * VOL}{CW} * \sum (C_i * A_{i0}) \quad (1.5)$$

where:

- D_o = dose or dose commitment to organ o (mrem). Total body dose can also be calculated using site-related total body dose commitment factor.
- A_{i0} = site-related ingestion dose commitment factor to the total body or any organ o for radionuclide i (mrem/hr per uCi/ml)
- C_i = average concentration of radionuclide i, in undiluted liquid effluent representative of the volume VOL (uCi/ml)
- VOL = volume of liquid effluent released (gal)
- CW = average circulating water discharge rate during release period (gal/min)
- 1.67E-02 = conversion factor (hr/min)

The site-related ingestion dose/dose commitment factors (A_{1o}) are presented in Table 1-3 and have been derived in accordance with the requirements of NUREG-0133 by the equation:

$$A_{1o} = 1.14E+05 [(UI * BI_1) + (UF * BF_1)] DF_1 \quad (1.6)$$

where:

- A_{1o} = composite dose parameter for the total body or critical organ o of an adult for radionuclide i, for the fish and invertebrate ingestion pathways (mrem/hr per uCi/ml)
- UI = adult invertebrate consumption (5 kg/yr)
- BI_1 = bioaccumulation factor for radionuclide i in invertebrates from Table 1-4 (pCi/kg per pCi/l)
- UF = adult fish consumption (21 kg/yr)
- BF_1 = bioaccumulation factor for radionuclide i in fish from Table 1-4 (pCi/kg per pCi/l)
- DF_1 = dose conversion factor for nuclide i for adults in pre-selected organ, o, from Table E-11 of Regulatory Guide 1.109 (mrem/pCi)
- 1.14E+05 = conversion factor (pCi/uCi * ml/kg per hr/yr)

The radionuclides included in the periodic dose assessment per the requirements of Technical Specification 3/4.11.1.2 are those as identified by gamma spectral analysis of the liquid waste samples collected and analyzed per the requirements of Technical Specification 3/4.11.1.1, Table 4.11-1.

Radionuclides requiring radiochemical analysis (e.g., Sr-89 and Sr-90) will be added to the dose analysis at a frequency consistent with the required minimum analysis frequency of Technical Specification Table 4.11-1.

1.4.2 Simplified Liquid Effluent Dose Calculation.

In lieu of the individual radionuclide dose assessment as presented in Section 1.4.1, the following simplified dose calculation equation may be used for demonstrating compliance with the dose limits of Technical Specification 3.11.1.2. (Refer to Appendix B for the derivation and justification for this simplified method.)

Total Body

$$D_{tb} = \frac{1.21E+03 * VOL}{CW} * \sum C_i \quad (1.7)$$

Maximum Organ

$$D_{max} = \frac{2.52E+04 * VOL}{CW} * \sum C_i \quad (1.8)$$

where:

- C_i = average concentration of radionuclide i , in undiluted liquid effluent representative of the volume VOL (uCi/ml)
- VOL = volume of liquid effluent released (gal)
- CW = average circulating water discharge rate during release period (gal/min)
- D_{tb} = conservatively evaluated total body dose (mrem)
- D_{max} = conservatively evaluated maximum organ dose (mrem)
- 1.21E+03 = conversion factor (hr/min) and the conservative total body dose conversion factor (Fe-59, total body -- 7.27E+04 mrem/hr per uCi/ml)
- 2.52E+04 = conversion factor (hr/min) and the conservative maximum organ dose conversion factor (Nb-95, GI-LLI -- 1.51E+06 mrem/hr per uCi/ml)

1.5 Secondary Side Radioactive Liquid Effluents and Dose

Calculations During Primary to Secondary Leakage

During periods of primary to secondary leakage (i.e., steam generator tube leaks), radioactive material will be transmitted from the primary system to the secondary system. The potential exists for the release of radioactive material to the off-site environment (Delaware River) via secondary system discharges. Potentially significant radioactive material levels and potential releases are controlled/monitored by the Steam Generator blowdown monitors (R19) and the Chemical Waste Basin monitor (R37).

However to ensure compliance with the regulatory limits on radioactive material releases, it may be desirable to account for potential releases from the secondary system during periods of primary to secondary leakage. Any potentially significant releases will be via the Chemical Waste Basin with the major source of activity being the Steam Generator blowdown.

With identified radioactive material levels in the secondary system, appropriate samples should be collected and analyzed for the principal gamma emitting radionuclides. Based on the identified radioactive material levels and the volume of water discharged, the resulting environmental doses may be calculated based on equation (1.5).

Because the release rate from the secondary system is indirect (e.g., SG blowdown is normally routed to condenser where the condensate clean-up system will remove much of the radioactive material), samples should be collected from the final release point (i.e., Chemical Waste Basin) for quantifying the radioactive material releases. However, for conservatism and ease of controlling and quantifying all potential release paths, it is prudent to sample the SG blowdown and to assume all radioactive material is released directly to the environment via the Chemical Waste Basin. This approach while not exact, is conservative and ensures timely analysis for regulatory compliance. Accounting for radioactive material retention of the condensate clean-up system ion exchange resins may be needed to more accurately account for actual releases.

1.6 Liquid Effluent Dose Projections

Technical Specification 3.11.1.3 requires that the liquid radioactive waste processing system be used to reduce the radioactive material levels in the liquid waste prior to release when the quarterly projected doses exceed:

- 0.375 mrem to the total body, or
- 1.25 mrem to any organ.

The applicable liquid waste processing system for maintaining radioactive material releases ALARA is the ion exchange system as delineated in Figure 1-3. Alternately, the waste evaporator as presented in the Salem FSAR has processing capabilities meeting the NRC ALARA design requirements and may be used in conjunction or in lieu of the ion exchange system for waste processing requirements in accordance with Technical Specification 3.11.1.3. These processing requirements are applicable to each unit individually. Exceeding the projected dose requiring processing prior to release for one unit does not in itself dictate processing requirements for the other unit.

Dose projections are made at least once per 31 days by the following equations:

$$D_{tbp} = D_{tb} (91 / d) \quad (1.9)$$

$$D_{maxp} = D_{max} (91 / d) \quad (1.10)$$

where:

- D_{tbp} = the total body dose projection for current calendar quarter (mrem)
- D_{tb} = the total body dose to date for current calendar quarter as determined by Equation 1.5 or 1.7 (mrem)
- D_{maxp} = the maximum organ dose projection for current calendar quarter (mrem)
- D_{max} = the maximum organ dose to date for current calendar quarter as determined by Equation 1.5 or 1.7 (mrem)
- d = the number of days to date for current calendar quarter
- 91 = the number of days in a calendar quarter

2.0 Gaseous Effluents

2.1 Radiation Monitoring Instrumentation and Controls

The gaseous effluent monitoring instrumentation and controls at Salem for controlling and monitoring normal radioactive material releases in accordance with the Radiological Effluent Technical Specifications are summarized as follows:

- 1) Waste Gas Holdup System - The vent header gases are collected by the waste gas holdup system. Gases may be recycled to provide cover gas for the CVCS hold-up tank or held in the waste gas tanks for decay prior to release. Waste gas decay tanks are batch released after sampling and analysis. The tanks are discharged via the Plant Vent. 1-R41D provides noble gas monitoring and automatic isolation of waste gas decay tank releases for Unit-1. This function is provided by 2-R41D for Unit-2.
- 2) Containment Purge and Pressure/Vacuum Relief - containment purges and pressure/vacuum reliefs are released to the atmosphere via the respective unit Plant Vent. Noble gas monitoring and auto isolation function are provided by 1-R41D for Unit-1 and 2-R41D for Unit-2. Additionally, in accordance with Technical Specification 3.3.3.9, Table 3.3-13, 1-R12A and 2-R12A may be used to provide the containment monitoring and automatic isolation function during purge and pressure/vacuum reliefs.
- 3) Plant Vent - The Plant Vent for each respective unit receives discharges from the waste gas hold-up system, condenser evacuation system, containment purge and pressure/vacuum reliefs, and the Auxiliary Building ventilation. Effluents are monitored by R41D, a flow through gross activity monitor (for noble gas monitoring). Additionally, in-line gross activity monitors (1-R16 and 2-R16) provide redundant back-up monitoring capabilities to the R41D monitors. Radioiodine and particulate sampling capabilities are provided by charcoal cartridge and filter medium samplers. Plant Vent flow rate is measured and as a back-up may be determined empirically as a function of fan operation (fan curves). Sampler flow rates are determined by flow rate instrumentation (e.g., venturi rotameter).

* The R12A monitors also provide the safety function of containment isolation in the event of a fuel handling accident during refueling. During MODE 6 in accordance with Technical Specification 3/4.3.3, Table 3.3-6, the R12A alarm/trip setpoint shall be established at twice background. This will provide containment isolation and indication of unexpected increases in containment airborne radioactive material levels which can be indicative of fuel degradation. The R41D monitor may also provide this function if the R12A monitor is inoperable during MODE 6.

Gaseous radioactive waste flow diagrams with the applicable, associated radiation monitoring instrumentation and controls are presented as Figures 2-1 and 2-2 for Units 1 and 2, respectively.

2.2 Gaseous Effluent Monitor Setpoint Determination

2.2.1 Containment and Plant Vent Monitor.

Per the requirements of Technical Specification 3.3.3.9, alarm setpoints shall be established for the gaseous effluent monitoring instrumentation to ensure that the release rate of noble gases does not exceed the limits of Specification 3.11.2.1, which corresponds to a dose rate at the SITE BOUNDARY of 500 mrem/year to the total body or 3000 mrem/year to the skin.

Based on a grab sample analysis of the applicable release (i.e., grab sample of the Containment atmosphere, waste gas decay tank, or Plant Vent), the radiation monitoring alarm setpoints may be established by the following calculation method. The measured radionuclide concentrations and release rate are used to calculate the fraction of the allowable release rate, as limited by Specification 3.11.2.1, by the equation:

$$\text{FRAC} = [4.72\text{E}+02 * X/Q * \text{VF} * \sum (C_i * K_i)] / 500 \quad (2.1)$$

$$\text{FRAC} = [4.72\text{E}+02 * X/Q * \text{VF} * \sum (C_i * (L_i + 1.1 M_i))] / 3000 \quad (2.2)$$

where:

- FRAC = fraction of the allowable release rate based on the identified radionuclide concentrations and the release flow rate
- X/Q = annual average meteorological dispersion to the controlling site boundary location (sec/m³)
- VF = ventilation system flow rate for the applicable release point and monitor (ft³/min)
- C_i = concentration of noble gas radionuclide i as determined by radioanalysis of grab sample (uCi/cm³)
- K_i = total body dose conversion factor for noble gas radionuclide i (mrem/yr per uCi/m³ from Table 2-1)
- L_i = beta skin dose conversion factor for noble gas radionuclide i (mrem/yr per uCi/m³ from Table 2-1)
- M_i = gamma air dose conversion factor for noble gas radionuclide i (mrem/yr per uCi/m³ from Table 2-1)
- 1.1 = mrem skin dose per mrad gamma air dose (mrem/mrad)
- 500 = total body dose rate limit (mrem/yr)
- 3000 = skin dose rate limit (mrem/yr)
- 4.72 E+02 = conversion factor (cm³/ft³ * min/sec)

Based on the more limiting FRAC (i.e., higher value) as determined above, the alarm setpoints for the applicable monitors (R16, R41D, and/or R12A) may be calculated by the equation:

$$SP = [AF * \sum C_i * SEN / FRAC] + bkg \quad (2.3)$$

where:

- SP = alarm setpoint corresponding to the maximum allowable release rate (cpm)
- SEN = monitor sensitivity (cpm per uCi/cm³)
- bkg = background of the monitor (cpm)
- AF = administrative allocation factor for the specific monitor and type release, which corresponds to the fraction of the total allowable release rate that is administratively allocated to the release.

The allocation factor (AF) is an administrative control imposed to ensure that combined releases from Salem Units 1 and 2 and Hope Creek will not exceed the regulatory limits on release rate from the site (i.e., the release rate limits of Technical Specification 3.11.2.1). Normally, the combined AF value for Salem Units 1 and 2 is equal to 0.5 (0.25 per unit), with the remainder 0.5 allocated to Hope Creek. Any increase in AF above 0.5 for the Salem Nuclear Generating Station will be coordinated with the Hope Creek Generating Station to ensure that the combined allocation factors for all units do not exceed 1.0.

2.2.2 Conservative Default Values.

A conservative alarm setpoint can be established, in lieu of the individual radionuclide evaluation based on the grab sample analysis, to eliminate the potential of periodically having to adjust the setpoint to reflect minor changes in radionuclide distribution and variations in release flow rate. The alarm setpoint may be conservatively determined by the default values presented in Table 2-2 and 2-3 for Units 1 and 2, respectively. These values are based upon:

- the maximum ventilation (or purge) flow rate;
- a radionuclide distribution comprised of 95% Xe-133, 2% Xe-135, 1% Xe-133m, 1% Kr-88 and 1% Kr-85; and
- an administrative allocation factor of 0.25 to conservatively ensure that any simultaneous releases from Salem Units 1 and 2 do not exceed the maximum allowable release rate. For this radionuclide distribution, the alarm setpoint based on the total body dose rate is more restrictive than the corresponding setpoint based on the skin dose rate.

* Adopted from ANSI N237-1976/ANS-18.1, Source Term Specifications, Table 6

2.3 Gaseous Effluent Instantaneous Dose Rate Calculations - 10 CFR 20

2.3.1 Site Boundary Dose Rate - Noble Gases.

Technical Specification 3.11.2.1a limits the dose rate at the SITE BOUNDARY due to noble gas releases to ≤ 500 mrem/yr, total body and ≤ 3000 mrem/yr, skin. Radiation monitor alarm setpoints are established to ensure that these release limits are not exceeded. In the event any gaseous releases from the station results in an alarm setpoint being exceeded, an evaluation of the SITE BOUNDARY dose rate resulting from the release shall be performed using the following equations:

$$D_{tb} = X/Q * \sum (K_i * Q_i) \quad (2.4)$$

and

$$D_s = X/Q * \sum ((L_i + 1.1M_i) * Q_i) \quad (2.5)$$

where:

- D_{tb} = total body dose rate (mrem/yr)
- D_s = skin dose rate (mrem/yr)
- X/Q = atmospheric dispersion to the controlling SITE BOUNDARY location (sec/m³)
- Q_i = average release rate of radionuclide i over the release period under evaluation (uCi/sec)
- K_i = total body dose conversion factor for noble gas radionuclide i (mrem/yr per uCi/m³, from Table 2-1)
- L_i = beta skin dose conversion factor for noble gas radionuclide i (mrem/yr per uCi/m³, from Table 2-1)
- M_i = gamma air dose conversion factor for noble gas radionuclide i (mrad/yr per uCi/m³, from Table 2-1)
- 1.1 = mrem skin dose per mrad gamma air dose (mrem/mrad)

As appropriate, simultaneous releases from Salem Units 1 and 2 and Hope Creek will be considered in evaluating compliance with the release rate limits of Specification 3.11.2.1a, following any release exceeding the above prescribed alarm setpoints.

Monitor indications (readings) may be averaged over a time period not to exceed 15 minutes when determining noble gas release rate based on correlation of the monitor reading and monitor sensitivity. The 15 minute averaging is needed to allow for reasonable monitor response to potentially changing radioactive material concentrations and to exclude potential electronic spikes in monitor readings that may be unrelated to radioactive material releases. As identified, any

electronic spiking monitor responses may be excluded from the analysis.

NOTE: For administrative purposes, more conservative alarm setpoints than those as prescribed above may be imposed. However, conditions exceeding these more limiting alarm setpoints do not necessarily indicate radioactive material release rates exceeding the limits of Technical Specification 3.11.2.1a. Provided actual releases do not result in radiation monitor indications exceeding alarm setpoint values based on the above criteria, no further analyses are required for demonstrating compliance with the limits of Specification 3.11.2.1a.

Actual meteorological conditions concurrent with the release period or the default, annual average dispersion parameters as presented in Table 2-4 may be used for evaluating the gaseous effluent dose rate.

2.3.2 Site Boundary Dose Rate - Radioiodine and Particulates.

Technical Specification 3.11.2.1.b limits the dose rate to ≤ 1500 mrem/yr greater than 8 days. To demonstrate compliance with this limit, an evaluation is performed at a frequency no greater than that corresponding to the sampling and analysis time period (e.g., nominally once per 7 days). The following equation shall be used for the dose rate evaluation:

$$D_o = X/Q * \sum (R_{io} * Q_i) \quad (2.6)$$

where:

- D_o = average organ dose rate over the sampling time period (mrem/yr)
- X/Q = atmospheric dispersion to the controlling SITE BOUNDARY location for the inhalation pathway (sec/m³)
- R_{io} = dose parameter for radionuclide i (mrem/yr per uCi/m³) and organ o for the child inhalation pathway from Table 2-5
- Q_i = average release rate over the appropriate sampling period and analysis frequency for radionuclide i -- I-131, I-133, tritium or other radionuclide in particulate form with half-life greater than 8 days (uCi/sec)

By substituting 1500 mrem/yr for D_o and solving for Q , an allowable release rate for I-131 can be determined. Based on the annual average meteorological dispersion (see Table 2-4) and the most limiting potential pathway, age group and organ (inhalation, child, thyroid -- $R_{io} = 1.62E+07$ mrem/yr per uCi/m³), the allowable release rate for I-131 is 42 uCi/sec. Reducing this release rate by a factor of 4 to account for potential dose contributions from other radioactive particulate material and other release points (e.g., Hope Creek), the corresponding release rate allocated to each of the Salem units is 10.5 uCi/sec.

For a 7 day period, which is the nominal sampling and analysis frequency for I-131, the cumulative release is 6.3 Ci. Therefore, as long as the I-131 releases in any 7 day period do not exceed 6.3 Ci, no additional analyses are needed for verifying compliance with the Technical Specification 3.11.2.1.b limits on allowable release rate.

2.4 Noble Gas Effluent Dose Calculations - 10 CFR 50

2.4.1 UNRESTRICTED AREA Dose - Noble Gases.

Technical Specification 3.11.2.2 requires a periodic assessment of releases of noble gases to evaluate compliance with the quarterly dose limits of ≤ 5 mrad, gamma-air and ≤ 10 mrad, beta-air and the calendar year limits ≤ 10 mrad, gamma-air and ≤ 20 mrad, beta-air. The limits are applicable separately to each unit and are not combined site limits. The following equations shall be used to calculate the gamma-air and beta-air doses:

$$D_g = 3.17E-08 * X/Q * \sum (M_i * Q_i) \quad (2.7)$$

and

$$D_b = 3.17E-08 * X/Q * \sum (N_i * Q_i) \quad (2.8)$$

where:

D_g = air dose due to gamma emissions for noble gas radionuclides (mrad)

D_b = air dose due to beta emissions for noble gas radionuclides (mrad)

X/Q = atmospheric dispersion to the controlling SITE BOUNDARY location (sec/m³)

Q_i = cumulative release of noble gas radionuclide i over the period of interest (uCi) where uCi = (uci/cc) (cc released) or (uCi/sec) (sec released)

M_i = air dose factor due to gamma emissions from noble gas radionuclide i (mrad/yr per uCi/m³, from Table 2-1)

N_i = air dose factor due to beta emissions from noble gas radionuclide i (mrad/yr per uCi/m³, Table 2-1)

3.17E-08 = conversion factor (yr/sec)

2.4.2 Simplified Dose Calculation for Noble Gases.

In lieu of the individual noble gas radionuclide dose assessment as presented above, the following simplified dose calculation equations shall be used for verifying compliance with the dose limits of Technical Specification 3.11.2.2. (Refer to Appendix C for the derivation and justification for this simplified method.)

$$D_g = \frac{3.17E-08}{0.50} * X/Q * M_{eff} * \sum Q_i \quad (2.9)$$

and

$$D_b = \frac{3.17E-08}{0.50} * X/Q * N_{eff} * \sum Q_i \quad (2.10)$$

where:

- M_{eff} = 5.3E+02, effective gamma-air dose factor (mrad/yr per uCi/m³)
- N_{eff} = 1.1E+03, effective beta-air dose factor (mrad/yr per uCi/m³)
- Q_i = cumulative release for all noble gas radionuclides (uCi) where uCi = (uCi/cc) (cc released) or (uCi/sec) (sec released)
- 0.50 = conservatism factor to account for potential variability in the radionuclide distribution

Actual meteorological conditions concurrent with the release period or the default, annual average dispersion parameters as presented in Table 2-4, may be used for the evaluation of the gamma-air and beta-air doses.

2.5 Radioiodine and Particulate Dose Calculations - 10 CFR 50

2.5.1 UNRESTRICTED AREA Dose - Radioiodine and Particulates.

In accordance with requirements of Technical Specification 3.11.2.3, a periodic assessment shall be performed to evaluate compliance with the quarterly dose limit of <7.5 mrem and calendar year limit <15 mrem to any organ. The following equation shall be used to evaluate the maximum organ dose due to releases of I-131, tritium and particulates with half-lives greater than 8 days:

$$D_{\text{eop}} = 3.17\text{E-}08 * W * SF_p * \sum (R_{i\text{op}} * Q_i) \quad (2.11)$$

where:

- D_{eop} = dose or dose commitment via all pathways p and controlling age group a (as identified in Table 2-4) to organ o, including the total body (mrem)
- W = atmospheric dispersion parameter to the controlling location(s) as identified in Table 2-4
- X/Q = atmospheric dispersion for inhalation pathway and H-3 dose contribution via other pathways (sec/m³)
- D/Q = atmospheric deposition for vegetation, milk and ground plane exposure pathways (m⁻²)
- $R_{i\text{op}}$ = dose factor for radionuclide i (mrem/yr per uCi/m³) or (m² - mrem/yr per uCi/sec) and organ o from Table 2-5 for each age group and the applicable pathway p as identified in Table 2-4. Values for $R_{i\text{op}}$ were derived in accordance with the methods described in NUREG-0133
- Q_i = cumulative release over the period of interest for radionuclide i -- I-131 or radioactive material in particulate form with half-life greater than 8 days(uCi).
- SF_p = annual seasonal correction factor to account for the fraction of the year that the applicable exposure pathway does not exist.
- = 1) For milk and vegetation exposure pathways:
= A six month fresh vegetation and grazing season (May through October) = 0.5
- 2) For inhalation and ground plane exposure pathways: = 1.0

For evaluating the maximum exposed individual, the infant age group is controlling for the milk pathway. Only the controlling age group as identified in Table 2-4 need be evaluated for compliance with Technical Specification 3.11.2.3.

2.5.2 Simplified Dose Calculation for Radioiodines and Particulates.

In lieu of the individual radionuclide (I-131 and particulates) dose assessment as presented above, the following simplified dose calculation equation may be used for verifying compliance with the dose limits of Technical Specification 3.11.2.3 (refer to Appendix D for the derivation and justification of this simplified method).

$$D_{\max} = 3.17E-08 * W * SF_p * R_{I-131} * \sum Q_i \quad (2.12)$$

where:

- D_{\max} = maximum organ dose (mrem)
 R_{I-131} = I-131 dose parameter for the thyroid for the identified controlling pathway
 = 1.05E+12, infant thyroid dose parameter with the grass-cow-milk pathway controlling
 (m^2 - mrem/yr per uCi/sec)
 W = D/Q for radioiodine, 2.1E-10 1/ m^2
 Q_i = cumulative release over the period of interest for radionuclide I -- I-131 or radioactive material in particulate from with half life greater than 8 days (uCi)

The location of exposure pathways and the maximum organ dose calculation may be based on the available pathways in the surrounding environment of Salem as identified by the annual land-use census (Technical Specification 3.12.2). Otherwise, the dose will be evaluated based on the predetermined controlling pathways as identified in Table 2-4.

2.6 Secondary Side Radioactive Gaseous Effluents and Dose Calculations

During periods of primary to secondary leakage, minor levels of radioactive material may be released via the secondary system to the atmosphere. Non-condensables (e.g., noble gases) will be predominately released via the condenser evacuation system and will be monitored and quantified by the routine plant vent monitoring and sampling system and procedures (e.g., R15 on condenser evacuation, R41D on plant vent, and the plant vent particulate and charcoal samplers).

However, if the Steam Generator blowdown is routed directly to the Chemical Waste Basin (via the SG blowdown flash tank) instead of being recycled through the condenser, it may be desirable to account for the potential atmospheric releases of radioiodines and particulates from the flash tank vent (i.e., releases due to moisture carry over). Since this pathway is not sampled or monitored, it is necessary to calculate potential releases.

Based on the guidance in NRC NUREG-0133, the releases of the radioiodines and particulates shall be calculated by the equation:

$$Q_i = C_i * R_{sgb} * F_{ft} * (1 - SQ_{ftv}) \quad (2.13)$$

where:

- Q_i = the release rate of radionuclide, i , from the steam generator flash tank vent (uCi/sec)
- C_i = the concentration of radionuclide, i , in the secondary coolant water averaged over not more than one week (uCi/ml)
- R_{sgb} = the steam generator blowdown rate to the flash tank (ml/sec)
- F_{ft} = the fraction of blowdown flashed in the tank determined from a heat balance taken around the flash tank at the applicable reactor power level
- SQ_{ftv} = the measured steam quality in the flash tank vent; or an assumed value of 0.85, based on NUREG-0017.

Tritium releases via the steam flashing may also be quantified using the above equation with the assumption of a steam quality (SQ_{ftv}) equal to 0. Since the H-3 will be associated with the water molecules, it is not necessary to account for the moisture carry-over which is the transport media for the radioiodines and particulates.

Based on the design and operating conditions at Salem, the fraction of blowdown converted to steam (F_{tt}) is approximately 0.48. The equation simplifies to the following:

$$Q_i = 0.072 C_i R_{sgb} \quad (2.14)$$

For H-3, the simplified equation is:

$$Q_i = 0.48 C_i R_{sgb} \quad (2.15)$$

Also during reactor shutdown operations with a radioactively contaminated secondary system, radioactive material may be released to the atmosphere via the atmospheric reliefs (PORV) and the safety reliefs on the main steam lines and via the steam driven auxiliary feed pump exhaust. The evaluation of the radioactive material concentration in the steam relative to that in the steam generator water is based on the guidance of NUREG-0017, Revision 1. The partitioning factors for the radioiodines is 0.01 and is 0.001 for all other particulate radioactive material. The resulting equation for quantifying releases via the atmospheric steam releases is:

$$Q_{ij} = 0.13 * (C_{ij} * SF_j) * PF_i \quad (2.16)$$

where:

- Q_{ij} = release rate of radionuclide i via pathway j, (uCi/sec)
- C_{ij} = concentration of radionuclide i, in pathway j, (uCi/sec)
- SF_j = steam flow for release pathway j
 - = 450,000 lb/hr per PORV
 - = 800,000 lb/hr per safety relief valve
 - = 50,000 lb/hr for auxiliary feed pump exhaust
- PF_i = partitioning factor, ratio of concentration in steam to that in the water in the steam generator
 - = 0.01 for radioiodines
 - = 0.005 for all other particulates
 - = 1.0 for H-3
- 0.13 = conversion factor - [(hr*ml) / (sec*lb)]

Any significant releases of noble gases via the atmospheric steam releases can be quantified in accordance with the calculation methods of the Salem Emergency Plan Implementation Procedure.

Alternately, the quantification of the release rate and cumulative releases may be based on actual samples of main steam collected at the R46 sample locations. The measured radionuclide concentration in the steam may be used for quantifying the noble gases, radioiodine and particulate releases.

Note: The expected mode of operation would be to isolate the affected steam generator, thereby reducing the potential releases during the shutdown/cool-down process. Use of the above calculation methods should consider actual operating conditions and release mechanisms.

The calculated quantities of radioactive materials may be used as inputs to the equation (2.11) or (2.12) to calculate offsite doses for demonstrating compliance with the Radiological Effluent Technical Specifications.

2.7 Gaseous Effluent Dose Projection

Technical Specification 3.11.2.4 requires that the GASEOUS RADWASTE TREATMENT SYSTEM and VENTILATION EXHAUST TREATMENT SYSTEM be used to reduce radioactive material levels prior to discharge when projected doses exceed one-half the annual design objective rate in any calendar quarter, i.e., exceeding:

- 0.625 mrad/quarter, gamma air;
- 1.25 mrad/quarter, beta air; or
- 1.875 mrem/quarter, maximum organ.

The applicable gaseous processing systems for maintaining radioactive material releases ALARA are the Auxiliary Building normal ventilation system (filtration systems # 1,2 and 3) and the Waste Gas Decay Tanks as delineated in Figures 2-3 and 2-4. Dose projections are performed at least once per 31 days by the following equations:

$$D_{gp} = D_g * (91 / d) \quad (2.17)$$

$$D_{bp} = D_b * (91 / d) \quad (2.18)$$

$$D_{maxp} = D_{max} * (91 / d) \quad (2.19)$$

where:

- D_{gp} = gamma air dose projection for current calendar quarter (mrad)
- D_g = gamma air dose to date for current calendar quarter as determined by Equation 2.7 or 2.9 (mrem)
- D_{bp} = beta air dose projection for current calendar quarter (mrad)
- D_b = beta air dose to date for current calendar quarter as determined by Equation 2.8 or 2.10 (mrem)
- D_{maxp} = maximum organ dose projection for current calendar quarter (mrem)
- D_{max} = maximum organ dose to date for current calendar quarter as determined by Equation 2.11 or 2.12 (mrem)
- d = number of days to date in current calendar quarter
- 91 = number of days in a calendar quarter

3.0 Special Dose Analyses

3.1 Doses Due To Activities Inside the SITE BOUNDARY

In accordance with Technical Specification 6.9.1.11, the Radioactive Effluent Release Report (RERR) must be submitted within 60 days after January 1st and July 1st of each year and shall include an assessment of radiation doses from radioactive liquid and gaseous effluents to MEMBERS OF THE PUBLIC due to their activities inside the SITE BOUNDARY.

The calculation methods as presented in Sections 2.4 and 2.5 may be used for determining the maximum potential dose to a MEMBER OF THE PUBLIC based on the parameters from Table 2-4 . The default value for the meteorological dispersion data as presented in Table 2-3 may be used if current year meteorology is unavailable at the time of NRC reporting. However, a follow-up evaluation shall be performed when the data becomes available.

3.2 Total dose to MEMBERS OF THE PUBLIC - 40 CFR 190

The Radioactive Effluent Release Report (RERR), submitted within 60 days after January 1st and July 1st of each year shall also include an assessment of the radiation dose to the likely most exposed MEMBER OF THE PUBLIC for reactor releases and other nearby uranium fuel cycle sources (including dose contributions from effluents and direct radiation from on-site sources). For the likely most exposed MEMBER OF THE PUBLIC in the vicinity of Artificial Island, the sources of exposure need only consider the Salem Nuclear Generating Station and the Hope Creek Nuclear Generating Station: No other fuel cycle facilities contribute to the MEMBER OF THE PUBLIC dose for the Artificial Island vicinity.

The dose contribution from the operation of Hope Creek Nuclear Generating Station will be estimated based on the methods as presented in the Hope Creek Offsite Dose Calculation Manual (HCGS ODCM).

As appropriate for demonstrating/evaluating compliance with the limits of Technical Specification 3.11.4 (40 CFR 190), the results of the environmental monitoring program may be used for providing data on actual measured levels of radioactive material in the actual pathways of exposure.

3.2.1 Effluent Dose Calculations

For purposes of implementing the surveillance requirements of Technical Specification 3/4.11.4 and the reporting requirements of 6.9.1.11 (RERR), dose calculations for the Salem Nuclear Generating Station may be performed using the calculation methods contained within this ODCM; the conservative controlling pathways and locations of Table 2-4 or the actual pathways and locations as identified by the land use census (Technical Specification 3/4.12.2) may be used.

Average annual meteorological dispersion parameters or meteorological conditions concurrent with the release period under evaluation may be used.

3.2.2 Direct Exposure Dose Determination.

Any potentially significant direct exposure contribution to off-site individual doses may be evaluated based on the results of the environmental measurements (e.g., TLD, ion chamber measurements) and/or by the use of a radiation transport and shielding calculation method.

Only during a non-typical condition will there exist any potential for significant on-site sources at Salem that would yield potentially significant off-site doses (i.e., in excess of 1 mrem per year to a MEMBER OF THE PUBLIC), that would require detailed evaluation for demonstrating compliance with 40 CFR 190.

However, should a situation exist where the direct exposure contribution is potentially significant, on-site measurements, off-site measurements and/or calculation techniques will be used for determination of dose for assessing 40 CFR 190 compliance.

4.0 Radiological Environmental Monitoring Program

4.1 Sampling Program

The operational phase of the Radiological Environmental Monitoring Program (REMP) is conducted in accordance with the requirements of Appendix A Technical Specification 3.12. The objectives of the program are:

- To determine whether any significant increases occur in the concentration of radionuclides in the critical pathways of exposure in the vicinity of Artificial Island;
- To determine if the operation of the Salem Nuclear Generating Stations has resulted in any increase in the inventory of long lived radionuclides in the environment;
- To detect any changes in the ambient gamma radiation levels; and
- To verify that SNGS operations have no detrimental effects on the health and safety of the public or on the environment.

The sampling requirements (type of samples, collection frequency and analysis) and sample locations are presented in Appendix E.

*NOTE: No public drinking water samples or irrigation water samples are taken as these pathways are not directly effected by liquid effluents discharged from Salem Generating Station.

4.2 Interlaboratory Comparison Program

Technical Specification 3.12.3 requires analyses be performed on radioactive material supplied as part of an Interlaboratory Comparison. Participation in an approved Interlaboratory Comparison Program provides a check on the preciseness of measurements of radioactive materials in environmental samples.

A summary of the Interlaboratory Comparison Program results will be provided in the Annual Radiological Environmental Operating Report pursuant to Technical Specification 6.9.1.10.

Liquid Release Flowpath Unit 1

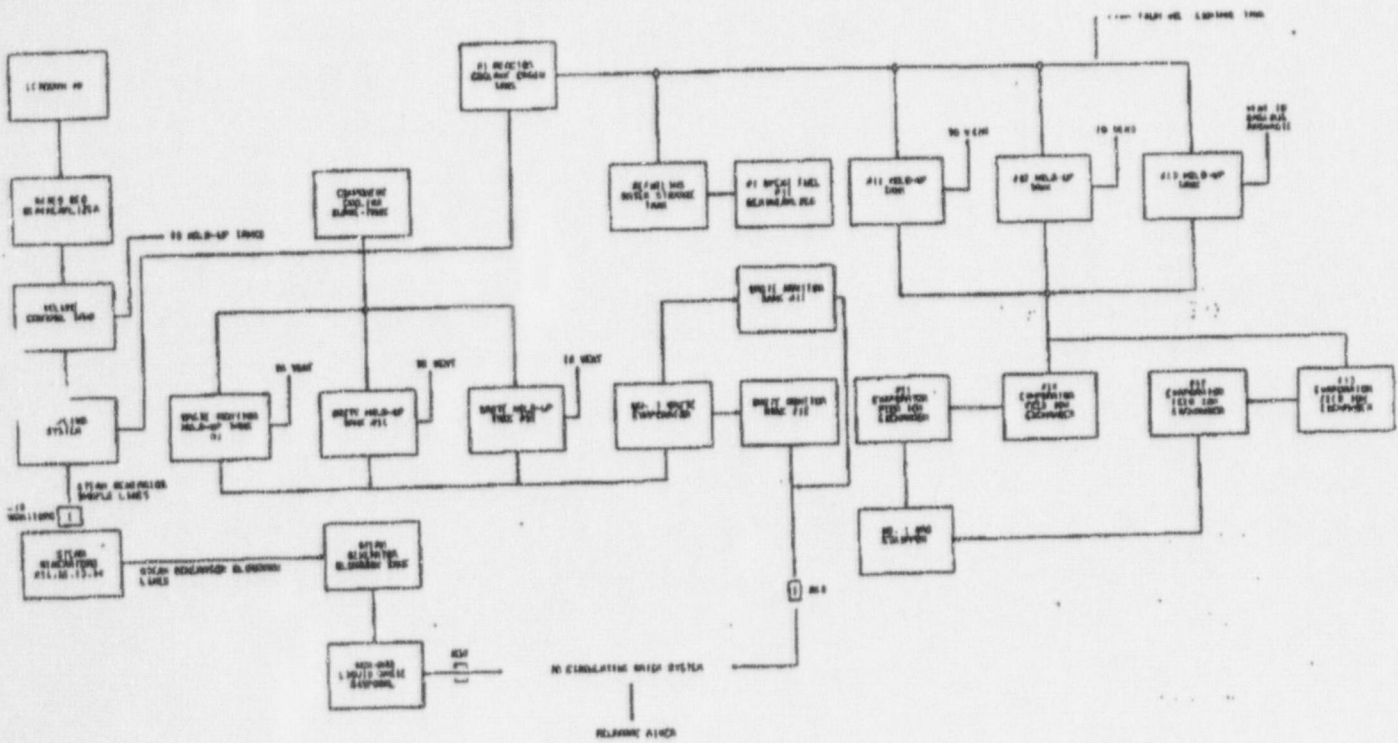

Liquid Release Flowpath Unit 2

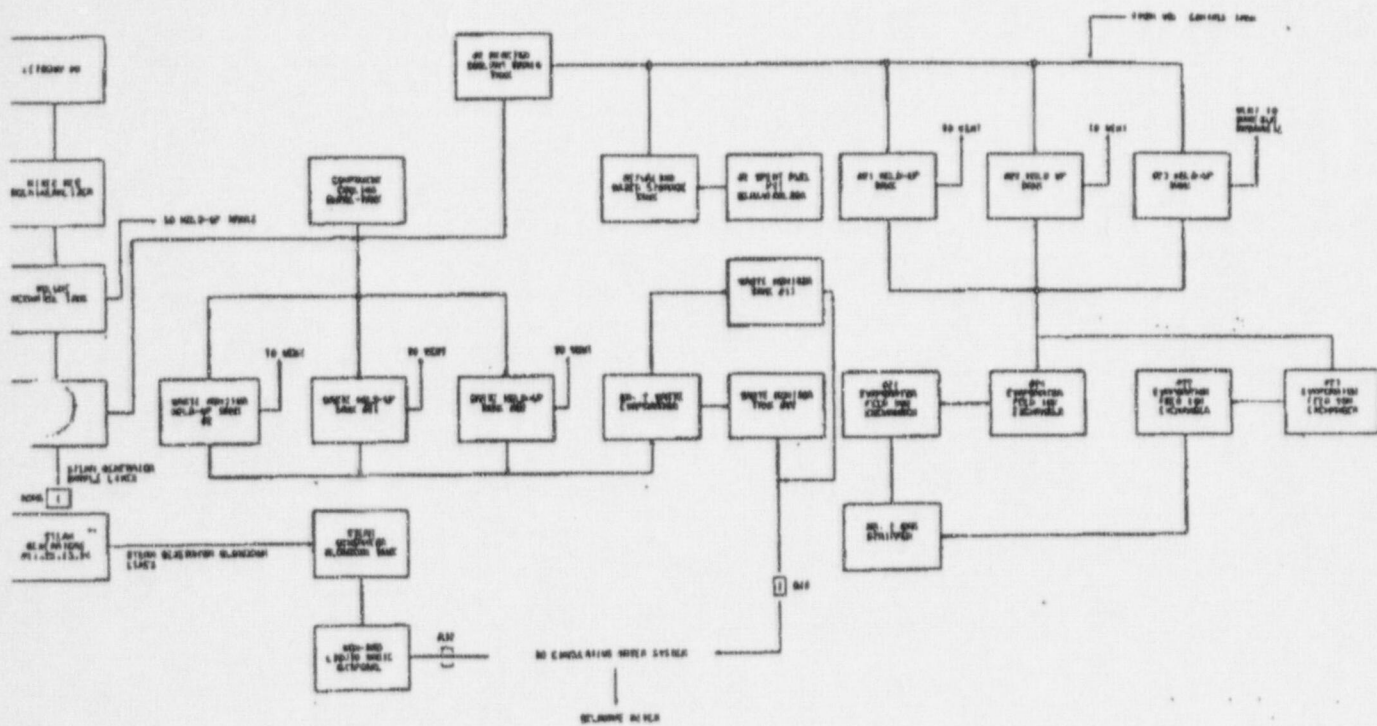

Radioactive Waste System

*NOTE: Evaporator package and/or
radioactive demineralizer system

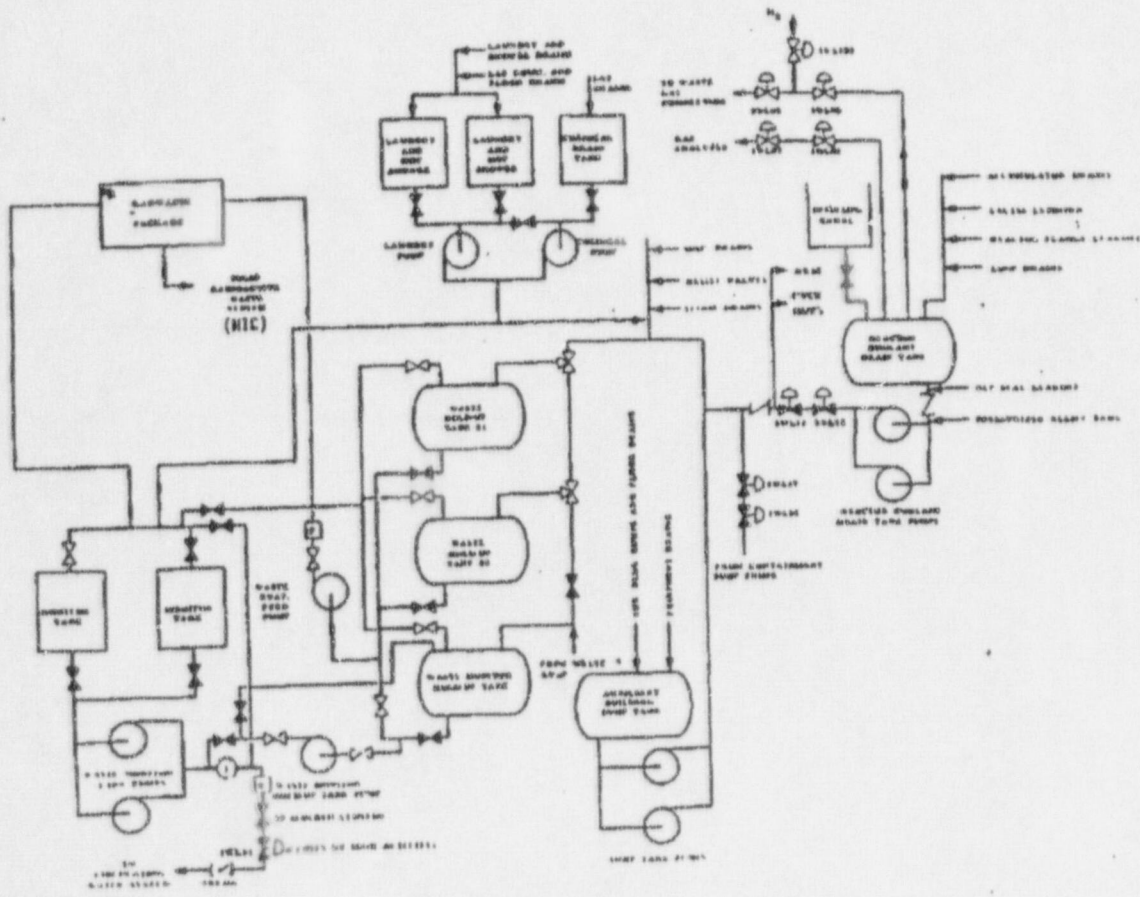

Table 1-1
Parameters for Liquid Alarm Setpoint Determinations
Unit 1

Parameter	Actual Value	Default Value	Units	Comments
MPC ₁	calculated	6.05E-06 *	uci/ml	Calculated for each batch to be released.
MPC I-131	3.0E-07	N/A	uci/ml	I-131 MPC conservatively used for SG blowdown and Service Water monitor setpoints.
C ₁	measured	N/A	uci/ml	Taken from gamma spectral analysis of liquid effluent.
MPC ₂	as determined	N/A	uci/ml	Taken from 10 CFR 20, Appendix B, Table II, Col 2.
Sensitivity 1-R18 1-R19 (A, B, C, D) 1-R13 (A, B, C, D, E)	as determined	N/A	cpm per uci/ml	Monitor sensitivities are controlled under Public Service Blueprint Document (PSBP) 315733
CW	as determined	1.00E+05	gpm	Circulating water system - single CW pump
RR 1-R18 1-R19 1-R13	as determined	120 120 2500	gpm	Determined prior to release; release rate can be adjusted for Technical Specification compliance Steam Generator blowdown rate per Generator Service Water flow rate for Containment fan coolers
Setpoint 1-R18 1-R19 ** 1-R13(A, B, C, D, E)**	calculated	N/A	cpm	Monitor setpoints are controlled under Public Service Blueprint Document (PSBP) 315733
Safety Factor (Non-Gamma)	as determined	0.75	Unitless	Default parameter to account for non-gamma emitting nuclides.

* Refer to Appendix A for derivation

** The MPC value of I-131 (3E-07 uci/ml) has been used for derivation of R19 Steam Generator blowdown and R13 Service Water monitor setpoints as discussed in Section 1.2.2

Table 1-2
Parameters for Liquid Alarm Setpoint Determinations
Unit 2

Parameter	Actual Value	Default Value	Units	Comments
MPC ₀	calculated	4.81E-06 *	uci/ml	Calculated for each batch to be released.
MPC I-131	3.0E-07	N/A	uci/ml	I-131 MPC conservatively used for SG blowdown, Service Water and Chemical Waste Basin monitor setpoints.
C ₁	measured	N/A	uci/ml	Taken from gamma spectral analysis of liquid effluent.
MPC ₁	as determined	N/A	uci/ml	Taken from 10 CFR 20, Appendix B, Table II, Col. 2
Sensitivity 2-R18 2-R19 (A, B, C, D) 2-R13 R37	as determined	N/A	cpm/uci/ml	Monitor sensitivities are controlled under Public Service Blueprint Document 315734
CW	as determined	1.0E+05	gpm	Circulating Water System, single CW pump (Note: no CW pump in service for 2R13 monitor - see section 1.2.2)
RR 2-R18	as determined	120	gpm	Determined prior to release; release rate can be adjusted for Technical Specification Compliance
2-R19		120		Steam Generator Blowdown rate per Generator
2-R13		2500		Service Water flow rate for Containment fan coolers
R37		1200		Chemical Waste Basin discharge
Setpoint 2-R18 2-R19 (A, B, C, D) 2-R13 ** R37 **	calculated	N/A	cpm	Monitor setpoints are controlled under Public Service Blueprint Document (PSBP) 315734
Safety Factor (Non-Gamma)	as determined	0.75	Unitless	Default parameter to account for non-gamma emitting nuclides.

* Refer to Appendix A for derivation

** The MPC value of I-131 (3.0E-7 uci/ml) has been used for derivation of the R13 and R37 monitor setpoints as discussed in Section 1.2.2

Table 1-3
Site Related Ingestion Dose Commitment Factors, Aio
(mrem/hr per uCi/ml)

Nuclide	Bone	Liver	T.Body	Thyroid	Kidney	Lung	GI-LLI
H-3	-	2.82E-1	2.82E-1	2.82E-1	2.82E-1	2.82E-1	2.82E-1
C-14	1.45E+4	2.90E+3	2.90E+3	2.90E+3	2.90E+3	2.90E+3	2.90E+3
Na-24	4.57E-1	4.57E-1	4.57E-1	4.57E-1	4.57E-1	4.57E-1	4.57E-1
P-32	4.69E+6	2.91E+5	1.81E+5	-	-	-	5.27E+5
Cr-51	-	-	5.58E+0	3.34E+0	1.23E+0	7.40E+0	1.40E+3
Mn-54	-	7.06E+3	1.35E+3	-	2.10E+3	-	2.16E+4
Mn-56	-	1.78E+2	3.15E+1	-	2.26E+2	-	5.67E+3
Fe-55	5.11E+4	3.53E+4	8.23E+3	-	-	1.97E+4	2.03E+4
Fe-59	8.06E+4	1.90E+5	7.27E+4	-	-	5.30E+4	6.32E+5
Co-57	-	1.42E+2	2.36E+2	-	-	-	3.59E+3
Co-58	-	6.03E+2	1.35E+3	-	-	-	1.22E+4
Co-60	-	1.73E+3	3.82E+3	-	-	-	3.25E+4
Ni-63	4.96E+4	3.44E+3	1.67E+3	-	-	-	7.18E+2
Ni-65	2.02E+2	2.62E+1	1.20E+1	-	-	-	6.65E+2
Cu-64	-	2.14E+2	1.01E+2	-	5.40E+2	-	1.83E+4
Zn-65	1.61E+5	5.13E+5	2.32E+5	-	3.43E+5	-	3.23E+5
Zn-69	3.43E+2	6.56E+2	4.56E+1	-	4.26E+2	-	9.85E+1
Br-82	-	-	4.07E+0	-	-	-	4.67E+0
Br-83	-	-	7.25E-2	-	-	-	1.04E-1
Br-84	-	-	9.39E-2	-	-	-	7.37E-7
Br-85	-	-	3.86E-3	-	-	-	-
Rb-86	-	6.24E+2	2.91E+2	-	-	-	1.23E+2
Rb-88	-	1.79E+0	9.49E-1	-	-	-	2.47E-11
Rb-89	-	1.19E+0	8.34E-1	-	-	-	6.89E-14
Sr-89	4.99E+3	-	1.43E+2	-	-	-	8.00E+2
Sr-90	1.23E+5	-	3.01E+4	-	-	-	3.55E+3
Sr-91	9.18E+1	-	3.71E+0	-	-	-	4.37E+2
Sr-92	3.48E+1	-	1.51E+0	-	-	-	6.90E+2
Y-90	6.06E+0	-	1.63E-1	-	-	-	6.42E+4
Y-91m	5.73E-2	-	2.22E-3	-	-	-	1.68E-1
Y-91	8.88E+1	-	2.37E+0	-	-	-	4.89E+4
Y-92	5.32E-1	-	1.56E-2	-	-	-	9.32E+3
Y-93	1.69E+0	-	4.66E-2	-	-	-	5.35E+4
Zr-95	1.59E+1	5.11E+0	3.46E+0	-	8.02E+0	-	1.62E+4
Zr-97	8.81E-1	1.78E-1	8.13E-2	-	2.68E-1	-	5.51E+4
Nb-95	4.47E+2	2.49E+2	1.34E+2	-	2.46E+2	-	1.51E+6
Nb-97	3.75E+0	9.49E-1	3.46E-1	-	1.11E+0	-	3.50E+3
Mo-99	-	1.28E+2	2.43E+1	-	2.89E+2	-	2.96E+2
Tc-99m	1.30E-2	3.66E-2	4.66E-1	-	5.56E-1	1.79E-2	2.17E+1
Tc-101	1.33E-2	1.92E-2	1.88E-1	-	3.46E-1	9.81E-3	5.77E-14
As-76	4.38E+2	1.16E+3	5.14E+3	3.42E+2	1.39E+3	3.58E+2	4.30E+4

Table 1-3 (cont'd)
 Site Related Ingestion Dose Commitment Factors, Aio
 (mrem/hr per uCi/ml)

Nuclide	Bone	Liver	T.Body	Thyroid	Kidney	Lung	GI-LLI
Ru-103	1.07E+2	-	4.60E+1	-	4.07E+2	-	1.25E+4
Ru-105	8.89E+0	-	3.51E+0	-	1.15E+2	-	5.44E+3
Ru-106	1.59E+3	-	2.01E+2	-	3.06E+3	-	1.03E+5
Rh-103m	-	-	-	-	-	-	-
Rh-106	-	-	-	-	-	-	-
Ag-110m	1.56E+3	1.45E+3	8.60E+2	-	2.85E+3	-	5.91E+5
Sb-124	2.77E+2	5.23E+0	1.10E+2	6.71E-1	-	2.15E+2	7.66E+3
Sb-125	1.77E+2	1.98E+0	4.21E+1	1.80E-1	-	1.36E+2	1.95E+3
Te-125m	2.17E+2	7.86E+1	2.91E+1	6.52E+1	8.82E+2	-	8.66E+2
Te-127m	5.48E+2	1.96E+2	6.68E+1	1.40E+2	2.23E+3	-	1.84E+3
Te-127	8.90E+0	3.20E+0	1.93E+0	6.60E+0	3.63E+1	-	7.03E+2
Te-129m	9.31E+2	3.47E+2	1.47E+2	3.20E+2	3.89E+3	-	4.69E+3
Te-129	2.54E+0	9.55E-1	6.19E-1	1.95E+0	1.07E+1	-	1.92E+0
Te-131m	1.40E+2	6.85E+1	5.71E+1	1.08E+2	6.94E+2	-	6.80E+3
Te-131	1.59E+0	6.66E-1	5.03E-1	1.31E+0	6.99E+0	-	2.26E-1
Te-132	2.04E+2	1.32E+2	1.24E+2	1.46E+2	1.27E+3	-	6.24E+3
I-130	3.96E+1	1.17E+2	4.61E+1	9.91E+3	1.82E+2	-	1.01E+2
I-131	2.18E+2	3.12E+2	1.79E+2	1.02E+5	5.35E+2	-	8.23E+1
I-132	1.06E+1	2.85E+1	9.96E+0	9.96E+2	4.54E+1	-	5.35E+0
I-133	7.45E+1	1.30E+2	3.95E+1	1.90E+4	2.26E+2	-	1.16E+2
I-134	5.56E+0	1.51E+1	5.40E+0	2.62E+2	2.40E+1	-	1.32E-2
I-135	2.32E+1	6.08E+1	2.24E+1	4.01E+3	9.75E+1	-	6.87E+1
Cs-134	6.84E+3	1.63E+4	1.33E+4	-	5.27E+3	1.75E+3	2.85E+2
Cs-136	7.16E+2	2.83E+3	2.04E+3	-	1.57E+3	2.16E+2	3.21E+2
Cs-137	8.77E+3	1.20E+4	7.85E+3	-	4.07E+3	1.35E+3	2.32E+2
Cs-138	6.07E+0	1.20E+1	5.94E+0	-	8.81E+0	8.70E-1	5.12E-5
Ba-139	7.85E+0	5.59E-3	2.30E-1	-	5.23E-3	3.17E-3	1.39E+1
Ba-140	1.64E+3	2.06E+0	1.08E+2	-	7.02E-1	1.18E+0	3.38E+3
Ba-141	3.81E+0	2.88E-3	1.29E-1	-	2.68E-3	1.63E-3	1.80E-9
Ba-142	1.72E+0	1.77E-3	1.08E-1	-	1.50E-3	1.00E-3	2.43E-18
La-140	1.57E+0	7.94E-1	2.10E-1	-	-	-	5.83E+4
La-142	8.06E-2	3.67E-2	9.13E-3	-	-	-	2.68E+2
Ce-141	3.43E+0	2.32E+0	2.63E-1	-	1.08E+0	-	8.86E+3
Ce-143	6.04E-1	4.46E+2	4.94E-2	-	1.97E-1	-	1.67E+4
Ce-144	1.79E+2	7.47E+1	9.59E+0	-	4.43E+1	-	6.04E+4
Pr-143	5.79E+0	2.32E+0	2.87E-1	-	1.34E+0	-	2.54E+4
Pr-144	1.90E-2	7.87E-3	9.64E-4	-	4.44E-3	-	2.73E-9
Nd-147	3.96E+0	4.58E+0	2.74E-1	-	2.68E+0	-	2.20E+4
W-187	9.16E+0	7.66E+0	2.68E+0	-	-	-	2.51E+3
Np-239	3.53E-2	3.47E-3	1.91E-3	-	1.08E-2	-	7.11E+2

Table 1-4
 Bioaccumulation Factors (Bfi)
 (pCi/kg per pCi/liter)

<u>Element</u>	<u>Saltwater Fish</u>	<u>Saltwater Invertebrae</u>
H	9.0E-01	9.3E-01
C	1.8E+03	1.4E+03
Na	6.7E-02	1.9E-01
P	3.0E+03	3.0E+04
Cr	4.0E+02	2.0E+03
Mn	5.5E+02	4.0E+02
Fe	3.0E+03	2.0E+04
Co	1.0E+02	1.0E+03
Ni	1.0E+02	2.5E+02
Cu	6.7E+02	1.7E+03
Zn	2.0E+03	5.0E+04
Br	1.5E-02	3.1E+00
Rb	8.3E+00	1.7E+01
Sr	2.0E+00	2.0E+01
Y	2.5E+01	1.0E+03
Zr	2.0E+02	8.0E+01
Nb	3.0E+04	1.0E+02
Mo	1.0E+01	1.0E+01
Tc	1.0E+01	5.0E+01
Ru	3.0E+00	1.0E+03
Rh	1.0E+01	2.0E+03
Ag	3.3E+03	3.3E+03
Sb	4.0E+01	5.4E+00
Te	1.0E+01	1.0E+02
I	1.0E+01	5.0E+01
Cs	4.0E+01	2.5E+01
Ba	1.0E+01	1.0E+02
La	2.5E+01	1.0E+03
Ce	1.0E+01	6.0E+02
Pr	2.5E+01	1.0E+03
Nd	2.5E+01	1.0E+03
W	3.0E+01	3.0E+01
Np	1.0E+01	1.0E+01
As	3.3E+02	3.3E+02

Values in this table are taken from Regulatory Guide 1.109 except for phosphorus (fish) which is adapted from NUREG/CR-1336 and silver, arsenic and antimony which are taken from UCRL 50564, Rev. 1, October 1972.

SALEM VENTILATION EXHAUST SYSTEMS AND EFFLUENT MONITOR INTERFACES
SIMPLIFIED ONE-LINE DIAGRAM

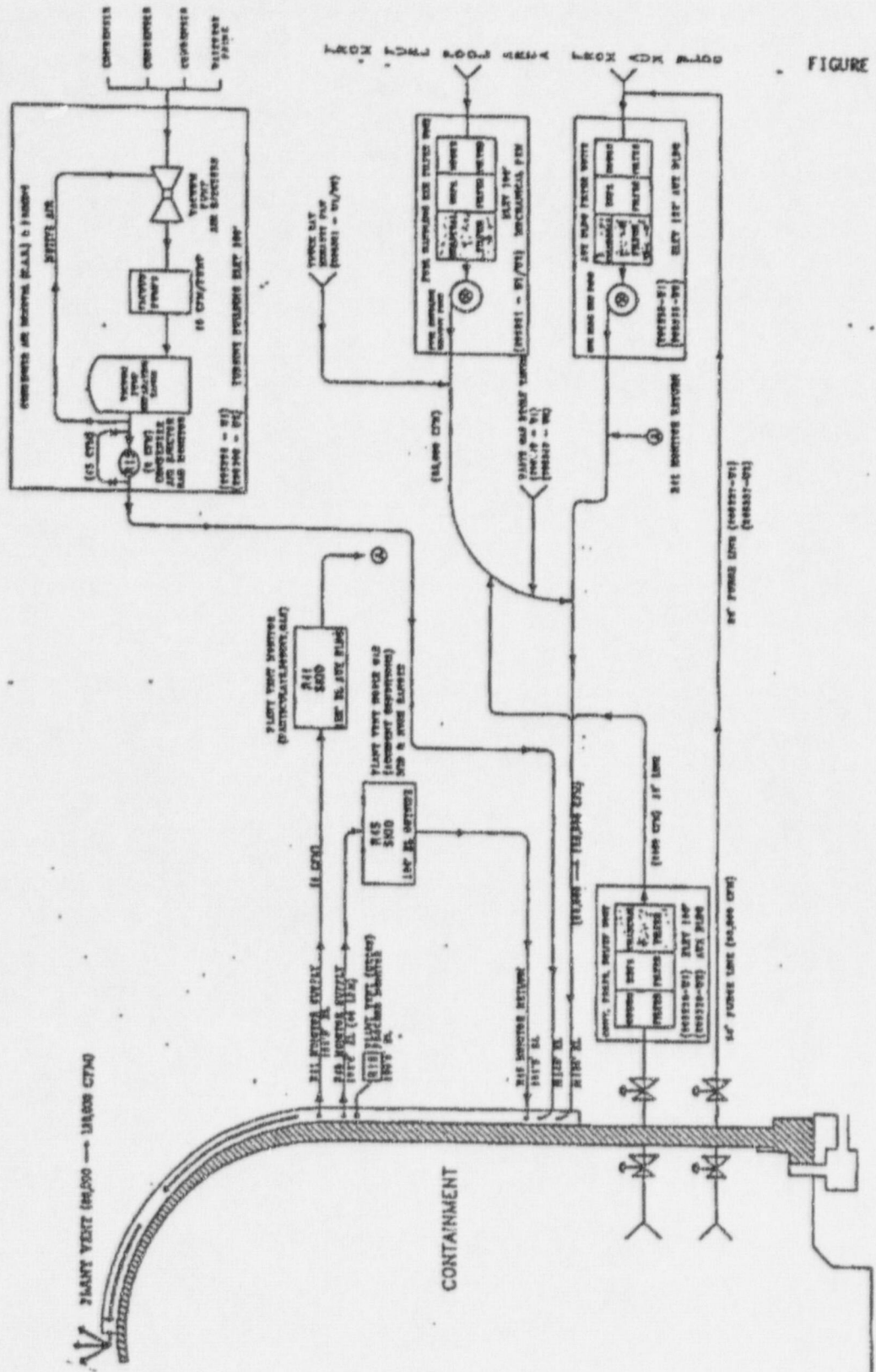

FIGURE 2-1

FIGURE 2-2

GASEOUS WASTE DISPOSAL SYSTEM
SIMPLIFIED FLOW DIAGRAM

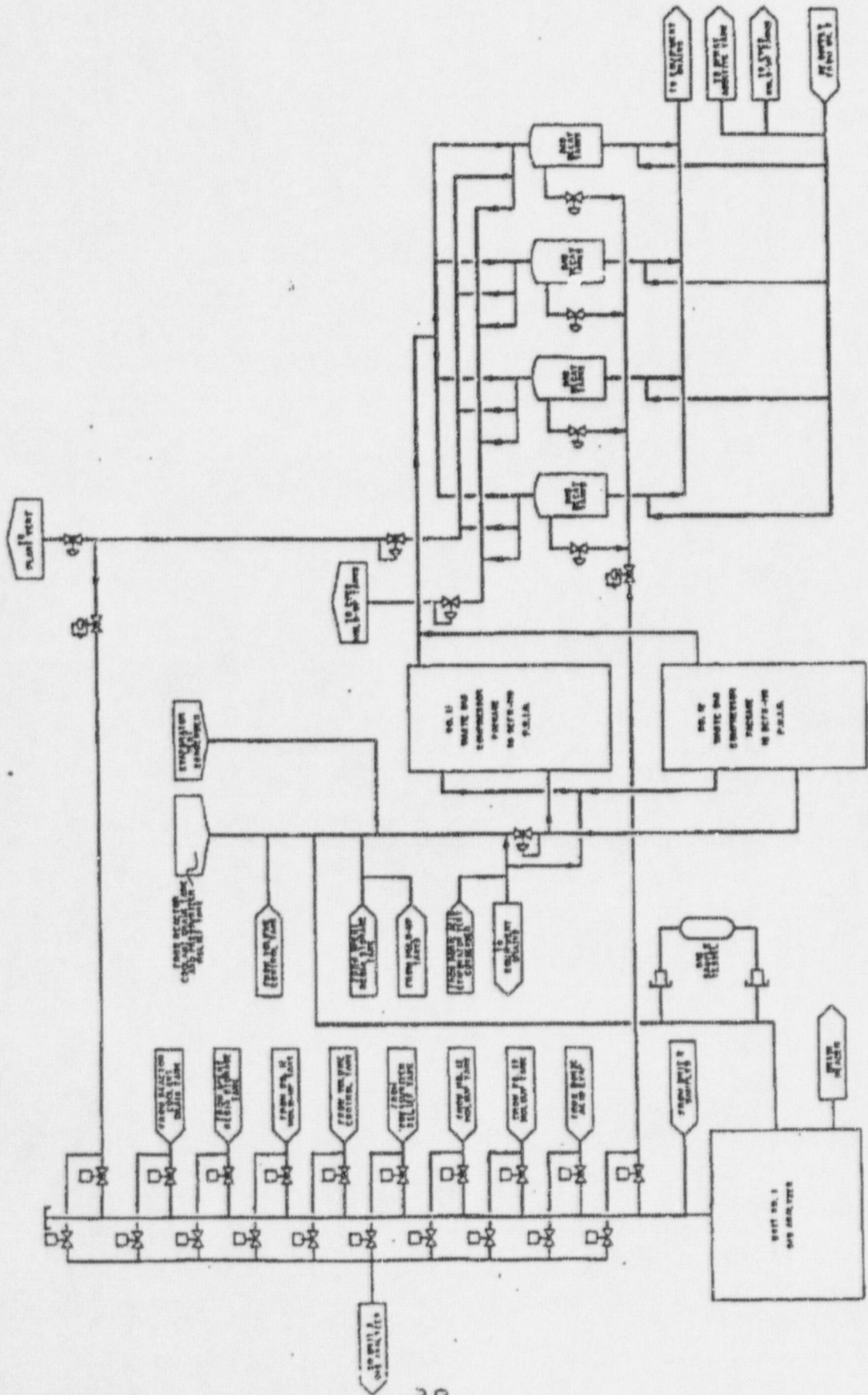

Table 2-1
Dose Factors for Noble Gases

Radionuclide	Total Body Dose Factor K1 (mrem/yr per uCi/m3)	Skin Dose Factor L1 (mrem/yr per uCi/m3)	Gamma Air Dose Factor M1 (mrad/yr per uCi/m3)	Beta Air Dose Factor N1 (mrad/yr per uCi/m3)
Kr-83m	7.56E-02	-----	1.93E+01	2.88E+02
Kr-85m	1.17E+03	1.46E+03	1.23E+03	1.97E+03
Kr-85	1.61E+01	1.34E+03	1.72E+01	1.95E+03
Kr-87	5.92E+03	9.73E+03	6.17E+03	1.03E+04
Kr-88	1.47E+04	2.37E+03	1.52E+04	2.93E+03
Kr-89	1.66E+04	1.01E+04	1.73E+04	1.06E+04
Kr-90	1.56E+04	7.29E+03	1.63E+04	7.63E+03
Xe-131m	9.15E+01	4.76E+02	1.56E+02	1.11E+03
Xe-133m	2.51E+02	9.94E+02	3.27E+02	1.48E+03
Xe-133	2.94E+02	3.06E+02	3.53E+02	1.05E+03
Xe-135m	3.12E+03	7.11E+02	3.36E+03	7.39E+02
Xe-135	1.81E+03	1.86E+03	1.92E+03	2.46E+03
Xe-137	1.42E+03	1.22E+04	1.51E+03	1.27E+04
Xe-138	8.83E+03	4.13E+03	9.21E+03	4.75E+03
Ar-41	8.84E+03	2.69E+03	9.30E+03	3.28E+03

Table 2-2
Parameters for Gaseous Alarm Setpoint Determinations
Unit 1

Parameter	Actual Value	Default Value	Units	Comments
X/Q	calculated	2.2E-06	sec/m ³	USNRC Salem Safety Evaluation, Sup 3
VF (Plant Vent) (Cont Purge)	as measured or fan curves	1.30E+05 3.50E+04	ft ³ /min	Plant Vent - normal operation Containment Purge
AF	coordinated	0.25	N/A	Administrative allocation factor with HCGS to ensure combined releases do not exceed release rate limit for site.
C _i	measured	N/A	uci/cm ₃	Taken from gamma spectral analysis of gaseous effluent
K _i	nuclide specific	N/A	mrem/yr per uci/m ³	Values from Table 2-1
L _i	nuclide specific	N/A	mrem/yr per uci/m ³	Values from Table 2-1
M _i	nuclide specific	N/A	mrem/yr per uci/m ³	Values from Table 2-1
Sensitivities 1-R41D 1-R16 1-R12A	as determined	N/A	cpm per uci/m ³	Monitor sensitivities are controlled under Public Service Blueprint Document (PSBP) 315733
Setpoint 1-R41D 1-R16 1-R12A **	calculated	N/A	cpm	Monitor setpoints are controlled under Public Service Blueprint Document (PSBP) 315733

** Applicable during Modes 1 through 5. During Mode 6 (refueling), monitor setpoint shall be reduced to 2x background in accordance with Technical Specification Table 3.3-6

Table 2-3
Parameters for Gaseous Alarm Setpoint Determinations
Unit 2

Parameter	Actual Value	Default Value	Units	Comments
X/Q	calculated	2.2E-6	sec/m ³	Licensing Technical Specification value
VF Plant Vent Cont. Purge	as measured or fan curves	1.30E+05 3.50E+04	ft ³ /min	Plant Vent - normal operation Containment Purge
AF	coordinated with HCGS	0.25	N/A	Administrative allocation factor to ensure combined releases do not exceed release rate for site.
C ₁	measured	N/A	uci/cm ³	Taken from gamma spectral analysis of gaseous effluent
K ₁	nuclide specific	N/A	mrem/yr per uci/m ³	Values from Table 2-1
L ₁	nuclide specific	N/A	mrem/yr per uci/m ³	Values from Table 2-1
M ₁	nuclide specific	N/A	mrem/yr per uci/m ³	Values from Table 2-1
Sensitivities 2-R41D 2-R16 2-R12A	as determined	N/A	cpm per uci/m ³	Monitor sensitivities are controlled under Public Service Blueprint Document (PSBP) 315734
Setpoint 2-R41D 2-R16 2-R12A **	calculated	N/A	cpm	Monitor setpoints are controlled under Public Service Blueprint Document (PSBP) 315734

** Applicable during MODES 1 through 5. During MODE 6 (refueling), monitor setpoints shall be reduced to 2x background in accordance with Technical Specification 3.3-6.

Table 2-4
 Controlling Locations, Pathways and
 Atmospheric Dispersion for Dose Calculations *

Technical Specification	Location	Pathway(s)	Atmospheric Dispersion		
			Controlling Age Group	X/Q (Sec/m ³)	D/Q (l/m ²)
3.11.2.1a	site boundary (0.83 mile, N)	noble gases direct exposure	N/A	2.2E-06	N/A
3.11.2.1b	site boundary (0.83 mile, N)	inhalation	child	2.2E-06	N/A
3.11.2.2	site boundary (0.83 mile, N)	gamma-air beta-air	N/A	2.2E-06	N/A
3.11.2.3	residence/dairy* (4.9 miles, W)	milk, ground plane and inhalation	infant	5.4E-08	2.1E-10

* Location and distance are determined from the performance of the annual land use census as required by Technical Specification 3.12.2.

* The identified controlling locations, pathways and atmospheric dispersion are from the Safety Evaluation Report, Supplement No. 3 for the Salem Nuclear Generating Station, Unit 2 (NUREG-0517, December 1978).

Table 2-5
 Pathway Dose Factors - Atmospheric Releases
 R(io), Inhalation Pathway Dose Factors - ADULT
 (mrem/yr per uCi/m³)

Nuclide	Bone	Liver	Thyroid	Kidney	Lung	GI-LLI	T.Body
H-3	-	1.26E+3	1.26E+3	1.26E+3	1.26E+3	1.26E+3	1.26E+3
C-14	1.82E+4	3.41E+3	3.41E+3	3.41E+3	3.41E+3	3.41E+3	3.41E+3
P-32	1.32E+6	7.71E+4	-	-	-	8.64E+4	5.01E+4
Cr-51	-	-	5.95E+1	2.28E+1	1.44E+4	3.32E+3	1.00E+2
Mn-54	-	3.96E+4	-	9.84E+3	1.40E+6	7.74E+4	6.30E+3
Fe-55	2.46E+4	1.70E+4	-	-	7.21E+4	6.03E+3	3.94E+3
Fe-59	1.18E+4	2.78E+4	-	-	1.02E+6	1.88E+5	1.06E+4
Co-57	-	6.92E+2	-	-	3.70E+5	3.14E+4	6.71E+2
Co-58	-	1.58E+3	-	-	9.28E+5	1.06E+5	2.07E+3
Co-60	-	1.15E+4	-	-	5.97E+6	2.85E+5	1.48E+4
Ni-63	4.32E+5	3.14E+4	-	-	1.78E+5	1.34E+4	1.45E+4
Zn-65	3.24E+4	1.03E+5	-	6.90E+4	8.64E+5	5.34E+4	4.66E+4
Rb-86	-	1.35E+5	-	-	-	1.66E+4	5.90E+4
Sr-89	3.04E+5	-	-	-	1.40E+6	3.50E+5	8.72E+3
Sr-90	9.92E+7	-	-	-	9.60E+6	7.22E+5	6.10E+6
Y-91	4.62E+5	-	-	-	1.70E+6	3.85E+5	1.24E+4
Zr-95	1.07E+5	3.44E+4	-	5.42E+4	1.77E+6	1.50E+5	2.33E+4
Nb-95	1.41E+4	7.82E+3	-	7.74E+3	5.05E+5	1.04E+5	4.21E+3
Ru-103	1.53E+3	-	-	5.83E+3	5.05E+5	1.10E+5	6.58E+2
Ru-106	6.91E+4	-	-	1.34E+5	9.36E+6	9.12E+5	8.72E+3
Ag-110m	1.08E+4	1.00E+4	-	1.97E+4	4.63E+6	3.02E+5	5.94E+3
Sb-124	3.12E+4	5.89E+2	7.55E+1	-	2.48E+6	4.06E+5	1.24E+4
Sb-125	5.34E+4	5.95E+2	5.40E+1	-	1.74E+6	1.01E+5	1.26E+4
Te-125m	3.42E+3	1.58E+3	1.05E+3	1.24E+4	3.14E+5	7.06E+4	4.67E+2
Te-127m	1.26E+4	5.77E+3	3.29E+3	4.58E+4	9.60E+5	1.50E+5	1.57E+3
Te-129m	9.76E+3	4.67E+3	3.44E+3	3.66E+4	1.16E+6	3.83E+5	1.58E+3
I-131	2.52E+4	3.58E+4	1.19E+7	6.13E+4	-	6.28E+3	2.05E+4
I-132	1.16E+3	3.26E+3	1.14E+5	5.13E+3	-	4.06E+2	1.16E+3
I-133	8.64E+3	1.48E+4	2.15E+6	2.58E+4	-	8.88E+3	4.52E+3
I-134	6.44E+2	1.73E+3	2.98E+4	2.75E+3	-	1.01E+0	6.15E+2
I-135	2.68E+3	6.98E+3	4.48E+5	1.11E+4	-	5.25E+3	2.57E+3
Cs-134	3.73E+5	8.48E+5	-	2.87E+5	9.76E+4	1.04E+4	7.28E+5
Cs-136	3.90E+4	1.46E+5	-	8.56E+4	1.20E+4	1.17E+4	1.10E+5
Cs-137	4.78E+5	6.21E+5	-	2.22E+5	7.52E+4	8.40E+3	4.28E+5
Ba-140	3.90E+4	4.90E+1	-	1.67E+1	1.27E+6	2.18E+5	2.57E+3
Ce-141	1.99E+4	1.35E+4	-	6.26E+3	3.62E+5	1.20E+5	1.53E+3
Ce-144	3.43E+6	1.43E+6	-	8.48E+5	7.78E+6	8.16E+5	1.84E+5
Pr-143	9.36E+3	3.75E+3	-	2.16E+3	2.81E+5	2.00E+5	4.64E+2
Nd-147	5.27E+3	6.10E+3	-	3.56E+3	2.21E+5	1.73E+5	3.65E+2

Table 2-5 (cont'd)
 R(io), Inhalation Pathway Dose Factors - TEENAGER
 (mrem/yr per uCi/m³)

Nuclide	Bone	Liver	Thyroid	Kidney	Lung	GI-LLI	T.Body
H-3	-	1.27E+3	1.27E+3	1.27E+3	1.27E+3	1.27E+3	1.27E+3
C-14	2.60E+4	4.87E+3	4.87E+3	4.87E+3	4.87E+3	4.87E+3	4.87E+3
P-32	1.89E+6	1.10E+5	-	-	-	9.28E+4	7.16E+4
Cr-51	-	-	7.50E+1	3.07E+1	2.10E+4	3.00E+3	1.35E+2
Mn-54	-	5.11E+4	-	1.27E+4	1.98E+6	6.68E+4	8.40E+3
Fe-55	3.34E+4	2.38E+4	-	-	1.24E+5	6.39E+3	5.54E+3
Fe-59	1.59E+4	3.70E+4	-	-	1.53E+6	1.78E+5	1.43E+4
Co-57	-	6.92E+2	-	-	5.86E+5	3.14E+4	9.20E+2
Co-58	-	2.07E+3	-	-	1.34E+6	9.52E+4	2.78E+3
Co-60	-	1.51E+4	-	-	8.72E+6	2.59E+5	1.98E+4
Ni-63	5.80E+5	4.34E+4	-	-	3.07E+5	1.42E+4	1.98E+4
Zn-65	3.86E+4	1.34E+5	-	8.64E+4	1.24E+6	4.66E+4	6.24E+4
Rb-86	-	1.90E+5	-	-	-	1.77E+4	8.40E+4
Sr-89	4.34E+5	-	-	-	2.42E+6	3.71E+5	1.25E+4
Sr-90	1.08E+8	-	-	-	1.65E+7	7.65E+5	6.68E+6
Y-91	6.61E+5	-	-	-	2.94E+6	4.09E+5	1.77E+4
Zr-95	1.46E+5	4.58E+4	-	6.74E+4	2.69E+6	1.49E+5	3.15E+4
Nb-95	1.86E+4	1.03E+4	-	1.00E+4	7.51E+5	9.68E+4	5.66E+3
Ru-103	2.10E+3	-	-	7.43E+3	7.83E+5	1.09E+5	8.96E+2
Ru-106	9.84E+4	-	-	1.90E+5	1.61E+7	9.60E+5	1.24E+4
Ag-110m	1.38E+4	1.31E+4	-	2.50E+4	6.75E+6	2.73E+5	7.99E+3
Sb-124	4.30E+4	7.94E+2	9.76E+1	-	3.85E+6	3.98E+5	1.68E+4
Sb-125	7.38E+4	8.08E+2	7.04E+1	-	2.74E+6	9.92E+4	1.72E+4
Te-125m	4.88E+3	2.24E+3	1.40E+3	-	5.36E+5	7.50E+4	6.67E+2
Te-127m	1.80E+4	8.16E+3	4.38E+3	6.54E+4	1.66E+6	1.59E+5	2.18E+3
Te-129m	1.39E+4	6.58E+3	4.58E+3	5.19E+4	1.98E+6	4.05E+5	2.25E+3
I-131	3.54E+4	4.91E+4	1.46E+7	8.40E+4	-	6.49E+3	2.64E+4
I-132	1.59E+3	4.38E+3	1.51E+5	6.92E+3	-	1.27E+3	1.58E+3
I-133	1.22E+4	2.05E+4	2.92E+6	3.59E+4	-	1.03E+4	6.22E+3
I-134	8.88E+2	2.32E+3	3.95E+4	3.66E+3	-	2.04E+1	8.40E+2
I-135	3.70E+3	9.44E+3	6.21E+5	1.49E+4	-	6.95E+3	3.49E+3
Cs-134	5.02E+5	1.13E+6	-	3.75E+5	1.46E+5	9.76E+3	5.49E+5
Cs-136	5.15E+4	1.94E+5	-	1.10E+5	1.78E+4	1.09E+4	1.37E+5
Cs-137	6.70E+5	8.48E+5	-	3.04E+5	1.21E+5	8.48E+3	3.11E+5
Ba-140	5.47E+4	6.70E+1	-	2.28E+1	2.03E+6	2.29E+5	3.52E+3
Ce-141	2.84E+4	1.90E+4	-	8.88E+3	6.14E+5	1.26E+5	3.17E+3
Ce-144	4.89E+6	2.02E+6	-	1.21E+6	1.34E+7	8.64E+5	2.62E+5
Pr-143	1.34E+4	5.31E+3	-	3.09E+3	4.83E+5	2.14E+5	6.62E+2
Nd-147	7.86E+3	8.56E+3	-	5.02E+3	3.72E+5	1.82E+5	5.13E+2

Table 2-5 (cont'd)
 R(io), Inhalation Pathway Dose Factors - CHILD
 (mrem/yr per uCi/m3)

Nuclide	Bone	Liver	Thyroid	Kidney	Lung	GI-LLI	T.Body
H-3	-	1.12E+3	1.12E+3	1.12E+3	1.12E+3	1.12E+3	1.12E+3
C-14	3.59E+4	6.73E+3	6.73E+3	6.73E+3	6.73E+3	6.73E+3	6.73E+3
P-32	2.60E+6	1.14E+5	-	-	-	4.22E+4	9.88E+4
Cr-51	-	-	8.55E+1	2.43E+1	1.70E+4	1.08E+3	1.54E+2
Mn-54	-	4.29E+4	-	1.00E+4	1.58E+6	2.29E+4	9.51E+3
Fe-55	4.74E+4	2.52E+4	-	-	1.11E+5	2.87E+3	7.77E+3
Fe-59	2.07E+4	3.34E+4	-	-	1.27E+6	7.07E+4	1.67E+4
Co-57	-	9.03E+2	-	-	5.07E+5	1.32E+4	1.07E+3
Co-58	-	1.77E+3	-	-	1.11E+6	3.44E+4	3.16E+3
Co-60	-	1.31E+4	-	-	7.07E+6	9.62E+4	2.25E+4
Ni-63	8.21E+5	4.63E+4	-	-	2.75E+5	6.33E+3	2.80E+4
Zn-65	4.26E+4	1.13E+5	-	7.14E+4	9.95E+5	1.63E+4	7.03E+4
Rb-86	-	1.98E+5	-	-	-	7.99E+3	1.14E+5
Sr-89	5.99E+5	-	-	-	2.16E+6	1.67E+5	1.72E+4
Sr-90	1.01E+8	-	-	-	1.48E+7	3.43E+5	6.44E+6
Y-91	9.14E+5	-	-	-	2.63E+6	1.84E+5	2.44E+4
Zr-95	1.90E+5	4.18E+4	-	5.96E+4	2.23E+6	6.11E+4	3.70E+4
Nb-95	2.35E+4	9.18E+3	-	8.62E+3	6.14E+5	3.70E+4	6.55E+3
Ru-103	2.79E+3	-	-	7.03E+3	6.62E+5	4.48E+4	1.07E+3
Ru-106	1.36E+5	-	-	1.84E+5	1.43E+7	4.29E+5	1.69E+4
Ag-110m	1.69E+4	1.14E+4	-	2.12E+4	5.48E+6	1.00E+5	9.14E+3
Sb-124	5.74E+4	7.40E+2	1.26E+2	-	3.24E+6	1.64E+5	2.00E+4
Sb-125	9.84E+4	7.59E+2	9.10E+1	-	2.32E+6	4.03E+4	2.07E+4
Te-125m	6.73E+3	2.33E+3	1.92E+3	-	4.77E+5	3.38E+4	9.14E+2
Te-127m	2.49E+4	8.55E+3	6.07E+3	6.36E+4	1.48E+6	7.14E+4	3.02E+3
Te-129m	1.92E+4	6.85E+3	6.33E+3	5.03E+4	1.76E+6	1.82E+5	3.04E+3
I-131	4.81E+4	4.81E+4	1.62E+7	7.88E+4	-	2.84E+3	2.73E+4
I-132	2.12E+3	4.07E+3	1.94E+5	6.25E+3	-	3.20E+3	1.88E+3
I-133	1.66E+4	2.03E+4	3.85E+6	3.38E+4	-	5.48E+3	7.70E+3
I-134	1.17E+3	2.16E+3	5.07E+4	3.30E+3	-	9.55E+2	9.95E+2
I-135	4.92E+3	8.73E+3	7.92E+5	1.34E+4	-	4.44E+3	4.14E+3
Cs-134	6.51E+5	1.01E+6	-	3.30E+5	1.21E+5	3.85E+3	2.25E+5
Cs-136	6.51E+4	1.71E+5	-	9.55E+4	1.45E+4	4.18E+3	1.15E+5
Cs-137	9.07E+5	8.25E+5	-	2.82E+5	1.04E+5	3.62E+3	1.28E+5
Ba-140	7.40E+4	6.48E+1	-	2.11E+1	1.74E+6	1.02E+5	4.33E+2
Ce-141	3.92E+4	1.95E+4	-	8.55E+3	5.44E+5	5.66E+4	2.90E+3
Ce-144	6.77E+6	2.12E+6	-	1.17E+6	1.20E+7	3.89E+5	3.61E+5
Pr-143	1.85E+4	5.55E+3	-	3.00E+3	4.33E+5	9.73E+4	9.14E+2
Nd-147	1.08E+4	8.73E+3	-	4.81E+3	3.28E+5	8.21E+4	6.81E+2

Table 2-5 (cont'd)
 R(io), Inhalation Pathway Dose Factors - INFANT
 (mrem/yr per uCi/m³)

Nuclide	Bone	Liver	Thyroid	Kidney	Lung	GI-LLI	T.Body
H-3	-	6.47E+2	6.47E+2	6.47E+2	6.47E+2	6.47E+2	6.47E+2
C-14	2.65E+4	5.31E+3	5.31E+3	5.31E+3	5.31E+3	5.31E+3	5.31E+3
P-32	2.03E+6	1.12E+5	-	-	-	1.61E+4	7.74E+4
Cr-51	-	-	5.75E+1	1.32E+1	1.28E+4	3.57E+2	8.95E+1
Mn-54	-	2.53E+4	-	4.98E+3	1.00E+6	7.06E+3	4.98E+3
Fe-55	1.97E+4	1.17E+4	-	-	8.69E+4	1.09E+3	3.33E+3
Fe-59	1.36E+4	2.35E+4	-	-	1.02E+6	2.48E+4	9.48E+3
Co-57	-	6.51E+2	-	-	3.79E+5	4.86E+3	6.41E+2
Co-58	-	1.22E+3	-	-	7.77E+5	1.11E+4	1.82E+3
Co-60	-	8.02E+3	-	-	4.51E+6	3.19E+4	1.18E+4
Ni-63	3.39E+5	2.04E+4	-	-	2.09E+5	2.42E+3	1.16E+4
Zn-65	1.93E+4	6.26E+4	-	3.25E+4	6.47E+5	5.14E+4	3.11E+4
Rb-86	-	1.90E+5	-	-	-	3.04E+3	8.82E+4
Sr-89	3.98E+5	-	-	-	2.03E+6	6.40E+4	1.14E+4
Sr-90	4.09E+7	-	-	-	1.12E+7	1.31E+5	2.59E+6
Y-91	5.88E+5	-	-	-	2.45E+6	7.03E+4	1.57E+4
Zr-95	1.15E+5	2.79E+4	-	3.11E+4	1.75E+6	2.17E+4	2.03E+4
Nb-95	1.57E+4	6.43E+3	-	4.72E+3	4.79E+5	1.27E+4	3.78E+3
Ru-103	2.02E+3	-	-	4.24E+3	5.52E+5	1.61E+4	6.79E+2
Ru-106	8.68E+4	-	-	1.07E+5	1.16E+7	1.64E+5	2.09E+1
Ag-110m	9.98E+3	7.22E+3	-	1.09E+4	3.67E+6	3.30E+4	5.00E+3
Sb-124	3.79E+4	5.56E+2	1.01E+2	-	2.65E+6	5.91E+4	1.20E+4
Sb-125	5.17E+4	4.77E+2	6.23E+1	-	1.64E+6	1.47E+4	1.09E+4
Te-125m	4.76E+3	1.99E+3	1.62E+3	-	4.47E+5	1.29E+4	6.58E+2
Te-127m	1.67E+4	6.90E+3	4.87E+3	3.75E+4	1.31E+6	2.73E+4	2.07E+3
Te-129m	1.41E+4	6.09E+3	5.47E+3	3.18E+4	1.68E+6	6.90E+4	2.23E+3
I-131	3.79E+4	4.44E+4	1.48E+7	5.18E+4	-	1.06E+3	1.96E+4
I-132	1.69E+3	3.54E+3	1.69E+5	3.95E+3	-	1.90E+3	1.26E+3
I-133	1.32E+4	1.92E+4	3.56E+6	2.24E+4	-	2.16E+3	5.60E+3
I-134	9.21E+2	1.88E+3	4.45E+4	2.09E+3	-	1.29E+3	6.65E+2
I-135	3.86E+3	7.60E+3	6.96E+5	8.47E+3	-	1.83E+3	2.77E+3
Cs-134	3.96E+5	7.03E+5	-	1.90E+5	7.97E+5	1.33E+3	7.45E+4
Cs-136	4.83E+4	1.35E+5	-	5.64E+4	1.18E+4	1.33E+3	5.29E+4
Cs-137	5.49E+5	6.12E+5	-	1.72E+5	7.13E+4	1.33E+3	4.55E+4
Ba-140	5.60E+4	5.60E+1	-	1.34E+1	1.60E+6	3.84E+4	2.90E+3
Ce-141	2.77E+4	1.67E+4	-	5.25E+3	5.17E+5	2.16E+4	1.99E+3
Ce-144	3.19E+6	1.21E+6	-	5.38E+5	9.84E+6	1.48E+5	1.76E+5
Pr-143	1.40E+4	5.24E+3	-	1.97E+3	4.33E+5	3.72E+4	6.99E+2
Nd-147	7.94E+3	8.13E+3	-	3.15E+3	3.22E+5	3.12E+4	5.00E+2

Table 2-5 (cont'd)
 R(10), Grass-Cow-Milk Pathway Dose Factors - ADULT
 (mrem/yr per uCi/m³) for H-3 and C-14
 (m² * mrem/yr per uCi/sec) for others

Nuclide	Bone	Liver	Thyroid	Kidney	Lung	GI-LLI	T.Body
H-3	-	7.63E+2	7.63E+2	7.63E+2	7.63E+2	7.63E+2	7.63E+2
C-14	3.63E+5	7.26E+4	7.26E+4	7.26E+4	7.26E+4	7.26E+4	7.26E+4
P-32	1.71E+10	1.06E+9	-	-	-	1.92E+9	6.60E+8
Cr-51	-	-	1.71E+4	6.30E+3	3.80E+4	7.20E+6	2.86E+4
Mn-54	-	8.40E+6	-	2.50E+6	-	2.57E+7	1.60E+6
Fe-55	2.51E+7	1.73E+7	-	-	9.67E+6	9.95E+6	4.04E+6
Fe-59	2.98E+7	7.00E+7	-	-	1.95E+7	2.33E+8	2.68E+7
Co-57	-	1.28E+6	-	-	-	3.25E+7	2.13E+6
Co-58	-	4.72E+6	-	-	-	9.57E+7	1.06E+7
Co-60	-	1.64E+7	-	-	-	3.08E+8	3.62E+7
Ni-63	6.73E+9	4.66E+8	-	-	-	9.73E+7	2.26E+8
Zn-65	1.37E+9	4.36E+9	-	2.92E+9	-	2.75E+9	1.97E+9
Rb-86	-	2.59E+9	-	-	-	5.11E+8	1.21E+9
Sr-89	1.45E+9	-	-	-	-	2.33E+8	4.16E+7
Sr-90	4.68E+10	-	-	-	-	1.35E+9	1.15E+10
Y-91	8.60E+3	-	-	-	-	4.73E+6	2.30E+2
Zr-95	9.46E+2	3.03E+2	-	4.76E+2	-	9.62E+5	2.05E+2
Nb-95	8.25E+4	4.59E+4	-	4.54E+4	-	2.79E+8	2.47E+4
Ru-103	1.02E+3	-	-	3.89E+3	-	1.19E+5	4.39E+2
Ru-106	2.04E+4	-	-	3.94E+4	-	1.32E+6	2.58E+3
Ag-110m	5.83E+7	5.39E+7	-	1.06E+8	-	2.20E+10	3.20E+7
Sb-124	2.57E+7	4.86E+5	6.24E+4	-	2.00E+7	7.31E+8	1.02E+7
Sb-125	2.04E+7	2.28E+5	2.08E+4	-	1.58E+7	2.25E+8	4.86E+6
Te-125m	1.63E+7	5.90E+6	4.90E+6	6.63E+7	-	6.50E+7	2.18E+6
Te-127m	4.58E+7	1.64E+7	1.17E+7	1.86E+8	-	1.54E+8	5.58E+6
Te-129m	6.04E+7	2.25E+7	2.08E+7	2.52E+8	-	3.04E+8	9.57E+6
I-131	2.96E+8	4.24E+8	1.39E+11	7.27E+8	-	1.12E+8	2.43E+8
I-132	1.64E-1	4.37E-1	1.53E+1	6.97E-1	-	8.22E-2	1.53E-1
I-133	3.97E+6	6.90E+6	1.01E+9	1.20E+7	-	6.20E+6	2.10E+6
I-134	-	-	-	-	-	-	-
I-135	1.39E+4	3.63E+4	2.40E+6	5.83E+4	-	4.10E+4	1.34E+4
Cs-134	5.65E+9	1.34E+10	-	4.35E+9	1.44E+9	2.35E+8	1.10E+10
Cs-136	2.61E+8	1.03E+9	-	5.74E+8	7.87E+7	1.17E+8	7.42E+8
Cs-137	7.38E+9	1.01E+10	-	3.43E+9	1.14E+9	1.95E+8	6.61E+9
Ba-140	2.69E+7	3.38E+4	-	1.15E+4	1.93E+4	5.54E+7	1.76E+6
Ce-141	4.84E+3	3.27E+3	-	1.52E+3	-	1.25E+7	3.71E+2
Ce-144	3.58E+5	1.50E+5	-	8.87E+4	-	1.21E+8	1.92E+4
Pr-143	1.59E+2	6.37E+1	-	3.68E+1	-	6.96E+5	7.88E+0
Nd-147	9.42E+1	1.09E+2	-	6.37E+1	-	5.23E+5	6.52E+0

Table 2-5 (cont'd)
 R(io), Grass-Cow-Milk Pathway Dose Factors - TEENAGER
 (mrem/yr per uCi/m³) for H-3 and C-14
 (m² * mrem/yr per uCi/sec) for others

Nuclide	Bone	Liver	Thyroid	Kidney	Lung	GI-LLI	T.Body
H-3	-	9.94E+2	9.94E+2	9.94E+2	9.94E+2	9.94E+2	9.94E+2
C-14	6.70E+5	1.34E+5	1.34E+5	1.34E+5	1.34E+5	1.34E+5	1.34E+5
P-32	3.15E+10	1.95E+9	-	-	-	2.65E+9	1.22E+9
Cr-51	-	-	2.78E+4	1.10E+4	7.13E+4	8.40E+6	5.00E+4
Mn-54	-	1.40E+7	-	4.17E+6	-	2.87E+7	2.78E+6
Fe-55	4.45E+7	3.16E+7	-	-	2.00E+7	1.37E+7	7.36E+6
Fe-59	5.20E+7	1.21E+8	-	-	3.82E+7	2.87E+8	4.68E+7
Co-57	-	2.25E+6	-	-	-	4.19E+7	3.76E+6
Co-58	-	7.95E+6	-	-	-	1.10E+8	1.83E+7
Co-60	-	2.78E+7	-	-	-	3.62E+8	6.26E+7
Ni-63	1.18E+10	8.35E+8	-	-	-	1.33E+8	4.01E+8
Zn-65	2.11E+9	7.31E+9	-	4.68E+9	-	3.10E+9	3.41E+9
Rb-86	-	4.73E+9	-	-	-	7.00E+8	2.22E+9
Sr-89	2.67E+9	-	-	-	-	3.18E+8	7.66E+7
Sr-90	6.61E+10	-	-	-	-	1.86E+9	1.63E+10
Y-91	1.58E+4	-	-	-	-	6.48E+6	4.24E+2
Zr-95	1.65E+3	5.22E+2	-	7.67E+2	-	1.20E+6	3.59E+2
Nb-95	1.41E+5	7.80E+4	-	7.57E+4	-	3.34E+8	4.30E+4
Ru-103	1.81E+3	-	-	6.40E+3	-	1.52E+5	7.75E+2
Ru-106	3.75E+4	-	-	7.23E+4	-	1.80E+6	4.73E+3
Ag-110m	9.63E+7	9.11E+7	-	1.74E+8	-	2.56E+10	5.54E+7
Sb-124	4.59E+7	8.46E+5	1.04E+5	-	4.01E+7	9.25E+8	1.79E+7
Sb-125	3.65E+7	3.99E+5	3.49E+4	-	3.21E+7	2.84E+8	8.54E+6
Te-125m	3.00E+7	1.08E+7	8.39E+6	-	-	8.86E+7	4.02E+6
Te-127m	8.44E+7	2.99E+7	2.01E+7	3.42E+8	-	2.10E+8	1.00E+7
Te-129m	1.11E+8	4.10E+7	3.57E+7	4.62E+8	-	4.15E+8	1.75E+7
I-131	5.38E+8	7.53E+8	2.20E+11	1.30E+9	-	1.49E+8	4.04E+8
I-132	2.90E-1	7.59E-1	2.56E+1	1.20E+0	-	3.31E-1	2.72E-1
I-133	7.24E+6	1.23E+7	1.72E+9	2.15E+7	-	9.30E+6	3.75E+6
I-134	-	-	-	-	-	-	-
I-135	2.47E+4	6.35E+4	4.08E+6	1.00E+5	-	7.03E+4	2.35E+4
Cs-134	9.81E+9	2.31E+10	-	7.34E+9	2.80E+9	2.87E+8	1.07E+10
Cs-136	4.45E+8	1.75E+9	-	9.53E+8	1.50E+8	1.41E+8	1.18E+9
Cs-137	1.34E+10	1.78E+10	-	6.06E+9	2.35E+9	2.53E+8	6.20E+9
Ba-140	4.85E+7	5.95E+4	-	2.02E+4	4.00E+4	7.49E+7	3.13E+6
Ce-141	8.87E+3	5.92E+3	-	2.79E+3	-	1.69E+7	6.81E+2
Ce-144	6.58E+5	2.72E+5	-	1.63E+5	-	1.66E+8	3.54E+4
Pr-143	2.92E+2	1.17E+2	-	6.77E+1	-	9.61E+5	1.45E+1
Nd-147	1.81E+2	1.97E+2	-	1.16E+2	-	7.11E+5	1.18E+1

Table 2-5 (cont'd)
 R(io), Grass-Cow-Milk Pathway Dose Factors - CHILD
 (mrem/yr per uCi/m3) for H-3 and C-14
 (m2 * mrem/yr per uCi/sec) for others

Nuclide	Bone	Liver	Thyroid	Kidney	Lung	GI-LLI	T.Body
H-3	-	1.57E+3	1.57E+3	1.57E+3	1.57E+3	1.57E+3	1.57E+3
C-14	1.65E+6	3.29E+5	3.29E+5	3.29E+5	3.29E+5	3.29E+5	3.29E+5
P-32	7.77E+10	3.64E+9	-	-	-	2.15E+9	3.00E+9
Cr-51	-	-	5.66E+4	1.55E+4	1.03E+5	5.41E+6	1.02E+5
Mn-54	-	2.09E+7	-	5.87E+6	-	1.76E+7	5.58E+6
Fe-55	1.12E+8	5.93E+7	-	-	3.35E+7	1.10E+7	1.84E+7
Fe-59	1.20E+8	1.95E+8	-	-	5.65E+7	2.03E+8	9.71E+7
Co-57	-	3.84E+6	-	-	-	3.14E+7	7.77E+6
Co-58	-	1.21E+7	-	-	-	7.08E+7	3.72E+7
Co-60	-	4.32E+7	-	-	-	2.39E+8	1.27E+8
Ni-63	2.96E+10	1.59E+9	-	-	-	1.07E+8	1.01E+9
Zn-65	4.13E+9	1.10E+10	-	6.94E+9	-	1.93E+9	6.85E+9
Rb-86	-	8.77E+9	-	-	-	5.64E+8	5.39E+9
Sr-89	6.62E+9	-	-	-	-	2.56E+8	1.89E+8
Sr-90	1.12E+11	-	-	-	-	1.51E+9	2.83E+10
Y-91	3.91E+4	-	-	-	-	5.21E+6	1.04E+3
Zr-95	3.84E+3	8.45E+2	-	1.21E+3	-	8.81E+5	7.52E+2
Nb-95	3.18E+5	1.24E+5	-	1.16E+5	-	2.29E+8	8.84E+4
Ru-103	4.29E+3	-	-	1.08E+4	-	1.11E+5	1.65E+3
Ru-106	9.24E+4	-	-	1.25E+5	-	1.44E+6	1.15E+4
Ag-110m	2.09E+8	1.41E+8	-	2.63E+8	-	1.68E+10	1.13E+8
Sb-124	1.09E+8	1.41E+8	2.40E+5	-	6.03E+7	6.79E+8	3.81E+7
Sb-125	8.70E+7	1.41E+6	8.06E+4	-	4.85E+7	2.08E+8	1.82E+7
Te-125m	7.38E+7	2.00E+7	2.07E+7	-	-	7.12E+7	9.84E+6
Te-127m	2.08E+8	5.60E+7	4.97E+7	5.93E+8	-	1.68E+8	2.47E+7
Te-129m	2.72E+8	7.61E+7	8.78E+7	8.00E+8	-	3.32E+8	4.23E+7
I-131	1.30E+9	1.31E+9	4.34E+11	2.15E+9	-	1.17E+8	7.46E+8
I-132	6.86E-1	1.26E+0	5.85E+1	1.93E+0	-	1.48E+0	5.80E-1
I-133	1.76E+7	2.18E+7	4.04E+9	3.63E+7	-	8.77E+6	8.23E+6
I-134	-	-	-	-	-	-	-
I-135	5.84E+4	1.05E+5	9.30E+6	1.61E+5	-	8.00E+4	4.97E+4
Cs-134	2.26E+10	3.71E+10	-	1.15E+10	4.13E+9	2.00E+8	7.83E+9
Cs-136	1.00E+9	2.76E+9	-	1.47E+9	2.19E+8	9.70E+7	1.79E+9
Cs-137	3.22E+10	3.09E+10	-	1.01E+10	3.62E+9	1.93E+8	4.55E+9
Ba-140	1.17E+8	1.03E+5	-	3.34E+4	6.12E+4	5.94E+7	6.84E+6
Ce-141	2.19E+4	1.09E+4	-	4.78E+3	-	1.36E+7	1.62E+3
Ce-144	1.62E+6	5.09E+5	-	2.82E+5	-	1.33E+8	8.66E+4
Pr-143	7.23E+2	2.17E+2	-	1.17E+2	-	7.80E+5	3.59E+1
Nd-147	4.45E+2	3.60E+2	-	1.98E+2	-	5.71E+5	2.79E+1

Table 2-5 (cont'd)
 R(io), Grass-Cow-Milk Pathway Dose Factors - INFANT
 (mrem/yr per uCi/m³) for H-3 and C-14
 (m² * mrem/yr per uCi/sec) for others

Nuclide	Bone	Liver	Thyroid	Kidney	Lung	GI-LLI	T.Body
H-3	-	2.38E+3	2.38E+3	2.38E+3	2.38E+3	2.38E+3	2.38E+3
C-14	3.23E+6	6.89E+5	6.89E+5	6.89E+5	6.89E+5	6.89E+5	6.89E+5
P-32	1.60E+11	9.42E+9	-	-	-	2.17E+9	6.21E+9
Cr-51	-	-	1.05E+5	2.30E+4	2.05E+5	4.71E+6	1.61E+5
Mn-54	-	3.89E+7	-	8.63E+6	-	1.43E+7	8.83E+6
Fe-55	1.35E+8	8.72E+7	-	-	4.27E+7	1.11E+7	2.33E+7
Fe-59	2.25E+8	3.93E+8	-	-	1.16E+8	1.88E+8	1.55E+8
Co-57	-	8.95E+6	-	-	-	3.05E+7	1.46E+7
Co-58	-	2.43E+7	-	-	-	6.05E+7	6.06E+7
Co-60	-	8.81E+7	-	-	-	2.10E+8	2.08E+8
Ni-63	3.49E+10	2.16E+9	-	-	-	1.07E+8	1.21E+9
Zn-65	5.55E+9	1.90E+10	-	9.23E+9	-	1.61E+10	8.78E+9
Rb-86	-	2.22E+10	-	-	-	5.69E+8	1.10E+10
Sr-89	1.26E+10	-	-	-	-	2.59E+8	3.61E+8
Sr-90	1.22E+11	-	-	-	-	1.52E+9	3.10E+10
Y-91	7.33E+4	-	-	-	-	5.26E+6	1.95E+3
Zr-95	6.83E+3	1.66E+3	-	1.79E+3	-	8.28E+5	1.18E+3
Nb-95	5.93E+5	2.44E+5	-	1.75E+5	-	2.06E+8	1.41E+5
Ru-103	8.69E+3	-	-	1.81E+4	-	1.06E+5	2.91E+3
Ru-106	1.90E+5	-	-	2.25E+5	-	1.44E+6	2.38E+4
Ag-110m	3.86E+8	2.82E+8	-	4.03E+8	-	1.46E+10	1.86E+8
Sb-124	2.09E+8	3.08E+6	5.56E+5	-	1.31E+8	6.46E+8	6.49E+7
Sb-125	1.49E+8	1.45E+6	1.87E+5	-	9.38E+7	1.99E+8	3.07E+7
Te-125m	1.51E+8	5.04E+7	5.07E+7	-	-	7.18E+7	2.04E+7
Te-127m	4.21E+8	1.40E+8	1.22E+8	1.04E+9	-	1.70E+8	5.10E+7
Te-129m	5.59E+8	1.92E+8	2.15E+8	1.40E+9	-	3.34E+8	8.62E+7
I-131	2.72E+9	3.21E+9	1.05E+12	3.75E+9	-	1.15E+8	1.41E+9
I-132	1.42E+0	2.89E+0	1.35E+2	3.22E+0	-	2.34E+0	1.03E+0
I-133	3.72E+7	5.41E+7	9.84E+9	6.36E+7	-	9.16E+6	1.58E+7
I-134	-	-	1.01E-9	-	-	-	-
I-135	1.21E+5	2.41E+5	2.16E+7	2.69E+5	-	8.74E+4	8.80E+4
Cs-134	3.65E+10	6.80E+10	-	1.75E+10	7.18E+9	1.85E+8	6.87E+9
Cs-136	1.96E+9	5.77E+9	-	2.30E+9	4.70E+8	8.76E+7	2.15E+9
Cs-137	5.15E+10	6.02E+10	-	1.62E+10	6.55E+9	1.88E+8	4.27E+9
Ba-140	2.41E+8	2.41E+5	-	5.73E+4	1.48E+5	5.92E+7	1.24E+7
Ce-141	4.33E+4	2.64E+4	-	8.15E+3	-	1.37E+7	3.11E+3
Ce-144	2.33E+6	9.52E+5	-	3.85E+5	-	1.33E+8	1.30E+5
Pr-143	1.49E+3	5.59E+2	-	2.08E+2	-	7.89E+5	7.41E+1
Nd-147	8.82E+2	9.06E+2	-	3.49E+2	-	5.74E+5	5.55E+1

Table 2-5 (cont'd)
 R(10), Vegetation Pathway Dose Factors - ADULT
 (mrem/yr per uCi/m³) for H-3 and C-14
 (m² * mrem/yr per uCi/sec) for others

Nuclide	Bone	Liver	Thyroid	Kidney	Lung	GI-LI.I	T.Body
H-3	-	2.26E+3	2.26E+3	2.26E+3	2.26E+3	2.26E+3	2.26E+3
C-14	8.97E+5	1.79E+5	1.79E+5	1.79E+5	1.79E+5	1.79E+5	1.79E+5
P-32	1.40E+9	8.73E+7	-	-	-	1.58E+8	5.42E+7
Cr-51	-	-	2.79E+4	1.03E+4	6.19E+4	1.17E+7	4.66E+4
Mn-54	-	3.11E+8	-	9.27E+7	-	9.54E+8	5.94E+7
Fe-55	2.09E+8	1.45E+8	-	-	8.06E+7	8.29E+7	3.37E+7
Fe-59	1.27E+8	2.99E+8	-	-	8.35E+7	9.96E+8	1.14E+8
Co-57	-	1.17E+7	-	-	-	2.97E+8	1.95E+7
Co-58	-	3.09E+7	-	-	-	6.26E+8	6.92E+7
Co-60	-	1.67E+8	-	-	-	3.14E+9	3.69E+8
Ni-63	1.04E+10	7.21E+8	-	-	-	1.50E+8	3.49E+8
Zn-65	3.17E+8	1.01E+9	-	6.75E+8	-	6.36E+8	4.56E+8
Rb-86	-	2.19E+8	-	-	-	4.32E+7	1.02E+8
Sr-89	9.96E+9	-	-	-	-	1.60E+9	2.86E+8
Sr-90	6.05E+11	-	-	-	-	1.75E+10	1.48E+11
Y-91	5.13E+6	-	-	-	-	2.82E+9	1.37E+5
Zr-95	1.19E+6	3.81E+5	-	5.97E+5	-	1.21E+9	2.58E+5
Nb-95	1.42E+5	7.91E+4	-	7.81E+4	-	4.80E+8	4.25E+4
Ru-103	4.80E+6	-	-	1.83E+7	-	5.61E+8	2.07E+6
Ru-106	1.93E+8	-	-	3.72E+8	-	1.25E+10	2.44E+7
Ag-110m	1.06E+7	9.76E+6	-	1.92E+7	-	3.98E+9	5.80E+6
Sb-124	1.04E+8	1.96E+6	2.52E+5	-	8.08E+7	2.95E+9	4.11E+7
Sb-125	1.36E+8	1.52E+6	1.39E+5	-	1.05E+8	1.50E+9	3.25E+7
Te-125m	9.66E+7	3.50E+7	2.90E+7	3.93E+8	-	3.86E+8	1.29E+7
Te-127m	3.49E+8	1.25E+8	8.92E+7	1.42E+9	-	1.17E+9	4.26E+7
Te-129m	2.55E+8	9.50E+7	8.75E+7	1.06E+9	-	1.28E+9	4.03E+7
I-131	8.09E+7	1.16E+8	3.79E+10	1.98E+8	-	3.05E+7	6.63E+7
I-132	5.74E+1	1.54E+2	5.38E+3	2.45E+2	-	2.89E+1	5.38E+1
I-133	2.12E+6	3.69E+6	5.42E+8	6.44E+6	-	3.31E+6	1.12E+6
I-134	1.06E-4	2.88E-4	5.00E-3	4.59E-4	-	2.51E-7	1.03E-4
I-135	4.08E+4	1.07E+5	7.04E+6	1.71E+5	-	1.21E+5	3.94E+4
Cs-134	4.66E+9	1.11E+10	-	3.59E+9	1.19E+9	1.94E+8	9.07E+9
Cs-136	4.20E+7	1.66E+8	-	9.24E+7	1.27E+7	1.89E+7	1.19E+8
Cs-137	6.36E+9	8.70E+9	-	2.95E+9	9.81E+8	1.68E+8	5.70E+9
Ba-140	1.29E+8	1.62E+5	-	5.49E+4	9.25E+4	2.65E+8	8.43E+6
Ce-141	1.96E+5	1.33E+5	-	6.17E+4	-	5.08E+8	1.51E+4
Ce-144	3.29E+7	1.38E+7	-	8.16E+6	-	1.11E+10	1.77E+6
Pr-143	6.34E+4	2.54E+4	-	1.47E+4	-	2.78E+8	3.14E+3
Nd-147	3.34E+4	3.86E+4	-	2.25E+4	-	1.85E+8	2.31E+3

Table 2-5 (cont'd)
 R(io), Vegetation Pathway Dose Factors - TEENAGER
 (mrem/yr per uCi/m3) for H-3 and C-14
 (m2 * mrem/yr per uCi/sec) for others

Nuclide	Bone	Liver	Thyroid	Kidney	Lung	GI-LLI	T.Body
H-3	-	2.59E+3	2.59E+3	2.59E+3	2.59E+3	2.59E+3	2.59E+3
C-14	1.45E+6	2.91E+5	2.91E+5	2.91E+5	2.91E+5	2.91E+5	2.91E+5
P-32	1.61E+9	9.96E+7	-	-	-	1.35E+8	6.23E+7
Cr-51	-	-	3.44E+4	1.36E+4	8.85E+4	1.04E+7	6.20E+4
Mn-54	-	4.52E+8	-	1.35E+8	-	9.27E+8	8.97E+7
Fe-55	3.25E+8	2.31E+8	-	-	1.46E+8	9.98E+7	5.38E+7
Fe-59	1.81E+8	4.22E+8	-	-	1.33E+8	9.98E+8	1.63E+8
Co-57	-	1.79E+7	-	-	-	3.34E+8	3.00E+7
Co-58	-	4.38E+7	-	-	-	6.04E+8	1.01E+8
Co-60	-	2.49E+8	-	-	-	3.24E+9	5.60E+8
Ni-63	1.61E+10	1.13E+9	-	-	-	1.81E+8	5.45E+8
Zn-65	4.24E+8	1.47E+9	-	9.41E+8	-	6.23E+8	6.86E+8
Rb-86	-	2.73E+8	-	-	-	4.05E+7	1.28E+8
Sr-89	1.51E+10	-	-	-	-	1.80E+9	4.33E+8
Sr-90	7.51E+11	-	-	-	-	2.11E+10	1.85E+11
Y-91	7.87E+6	-	-	-	-	3.23E+9	2.11E+5
Zr-95	1.74E+6	5.49E+5	-	8.07E+5	-	1.27E+9	3.78E+5
Nb-95	1.92E+5	1.06E+5	-	1.03E+5	-	4.55E+8	5.86E+4
Ru-103	6.87E+6	-	-	2.42E+7	-	5.74E+8	2.94E+6
Ru-106	3.09E+8	-	-	5.97E+8	-	1.48E+10	3.90E+7
Ag-110m	1.52E+7	1.44E+7	-	2.74E+7	-	4.04E+9	8.74E+6
Sb-124	1.55E+8	2.85E+6	3.51E+5	-	1.35E+8	3.11E+9	6.03E+7
Sb-125	2.14E+8	2.34E+6	2.04E+5	-	1.88E+8	1.66E+9	5.00E+7
Te-125m	1.48E+8	5.34E+7	4.14E+7	-	-	4.37E+8	1.98E+7
Te-127m	5.51E+8	1.96E+8	1.31E+8	2.24E+9	-	1.37E+9	6.56E+7
Te-129m	3.67E+8	1.36E+8	1.18E+8	1.54E+9	-	1.38E+9	5.81E+7
I-131	7.70E+7	1.08E+8	3.14E+10	1.85E+8	-	2.13E+7	5.79E+7
I-132	5.18E+1	1.36E+2	4.57E+3	2.14E+2	-	5.91E+1	4.87E+1
I-133	1.97E+6	3.34E+6	4.66E+8	5.86E+6	-	2.53E+6	1.02E+6
I-134	9.59E-5	2.54E-4	4.24E-3	4.01E-4	-	3.35E-6	9.13E-5
I-135	3.68E+4	9.48E+4	6.10E+6	1.50E+5	-	1.05E+5	3.52E+4
Cs-134	7.09E+9	1.67E+10	-	5.30E+9	2.02E+9	2.08E+8	7.74E+9
Cs-136	4.29E+7	1.69E+8	-	9.19E+7	1.45E+7	1.36E+7	1.13E+8
Cs-137	1.01E+10	1.35E+10	-	4.59E+9	1.78E+9	1.92E+8	4.69E+9
Ba-140	1.38E+8	1.69E+5	-	5.75E+4	1.14E+5	2.13E+8	8.91E+6
Ce-141	2.82E+5	1.88E+5	-	8.86E+4	-	5.38E+8	2.16E+4
Ce-144	5.27E+7	2.18E+7	-	1.30E+7	-	1.33E+10	2.83E+6
Pr-143	7.12E+4	2.84E+4	-	1.65E+4	-	2.34E+8	3.55E+3
Nd-147	3.63E+4	3.94E+4	-	2.32E+4	-	1.42E+8	2.36E+3

Table 2-5 (cont'd)
 R(10), Vegetation Pathway Dose Factors - CHILD
 (mrem/yr per uCi/m³) for H-3 and C-14
 (m² * mrem/yr per uCi/sec) for others

Nuclide	Bone	Liver	Thyroid	Kidney	Lung	GI-LLI	T.Body
H-3	-	4.01E+3	4.01E+3	4.01E+3	4.01E+3	4.01E+3	4.01E+3
C-14	3.50E+6	7.01E+5	7.01E+5	7.01E+5	7.01E+5	7.01E+5	7.01E+5
P-32	3.37E+9	1.58E+8	-	-	-	9.30E+7	1.30E+8
Cr-51	-	-	6.54E+4	1.79E+4	1.19E+5	6.25E+6	1.18E+5
Mn-54	-	6.61E+8	-	1.85E+8	-	5.55E+8	1.76E+8
Fc-55	8.00E+8	4.24E+8	-	-	2.40E+8	7.86E+7	1.31E+8
Fe-59	4.01E+8	6.49E+8	-	-	1.88E+8	6.76E+8	3.23E+8
Co-57	-	2.99E+7	-	-	-	2.45E+8	6.04E+7
Co-58	-	6.47E+7	-	-	-	3.77E+8	1.98E+8
Co-60	-	3.78E+8	-	-	-	2.10E+9	1.12E+9
Ni-63	3.95E+10	2.11E+9	-	-	-	1.42E+8	1.34E+9
Zn-65	8.12E+8	2.16E+9	-	1.36E+9	-	3.80E+8	1.35E+9
Rb-86	-	4.52E+8	-	-	-	2.91E+7	2.78E+8
Sr-89	3.59E+10	-	-	-	-	1.39E+9	1.03E+9
Sr-90	1.24E+12	-	-	-	-	1.67E+10	3.15E+11
Y-91	1.87E+7	-	-	-	-	2.49E+9	5.01E+5
Zr-95	3.90E+6	8.58E+5	-	1.23E+6	-	8.95E+8	7.64E+5
Nb-95	4.10E+5	1.59E+5	-	1.50E+5	-	2.95E+8	1.14E+5
Ru-103	1.55E+7	-	-	3.89E+7	-	3.99E+8	5.94E+6
Ru-106	7.45E+8	-	-	1.01E+9	-	1.16E+10	9.30E+7
Ag-110m	3.22E+7	2.17E+7	-	4.05E+7	-	2.58E+9	1.74E+7
Sb-124	3.52E+8	4.57E+6	7.78E+5	-	1.96E+8	2.20E+9	1.23E+8
Sb-125	4.99E+8	3.85E+6	4.62E+5	-	2.78E+8	1.19E+9	1.05E+8
Te-125m	3.51E+8	9.50E+7	9.84E+7	-	-	3.38E+8	4.67E+7
Te-127m	1.32E+9	3.56E+8	3.16E+8	3.77E+9	-	1.07E+9	1.57E+8
Te-129m	8.54E+8	2.39E+8	2.75E+8	2.51E+9	-	1.04E+9	1.33E+8
I-131	1.43E+8	1.44E+8	4.76E+10	2.36E+8	-	1.28E+7	8.18E+7
I-132	9.20E+1	1.69E+2	7.84E+3	2.59E+2	-	1.99E+2	7.77E+1
I-133	3.59E+6	4.44E+6	8.25E+8	7.40E+6	-	1.79E+6	1.68E+6
I-134	1.70E-4	3.16E-4	7.28E-3	4.84E-4	-	2.10E-4	1.46E-4
I-135	6.54E+4	1.18E+5	1.04E+7	1.81E+5	-	8.98E+4	5.57E+4
Cs-134	1.60E+10	2.63E+10	-	8.14E+9	2.92E+9	1.42E+8	5.54E+9
Cs-136	8.06E+7	2.22E+8	-	1.18E+8	1.76E+7	7.79E+6	1.43E+8
Cs-137	2.39E+10	2.29E+10	-	7.46E+9	2.68E+9	1.43E+8	3.38E+9
Ba-140	2.77E+8	2.43E+5	-	7.90E+4	1.45E+5	1.40E+8	1.62E+7
Ce-141	6.53E+5	3.26E+5	-	1.43E+5	-	4.07E+8	4.84E+4
Ce-144	1.27E+8	3.98E+7	-	2.21E+7	-	1.04E+10	6.78E+6
Pr-143	1.48E+5	4.46E+4	-	2.41E+4	-	1.50E+8	7.37E+3
Nd-147	7.16E+4	5.80E+4	-	3.18E+4	-	9.18E+7	4.49E+3

Table 2-5 (cont'd)
 R(10), Ground Plane Pathway Dose Factors
 (m2 * mrem/yr per uCi/sec)

Nuclide	Any Organ
H-3	-
C-14	-
P-32	-
Cr-51	4.68E+6
Mn-54	1.34E+9
Fe-55	-
Fe-59	2.75E+8
Co-58	3.82E+8
Co-60	2.16E+10
Ni-63	-
Zn-65	7.45E+8
Rb-86	8.98E+6
Sr-89	2.16E+4
Sr-90	-
Y-91	1.08E+6
Zr-95	2.48E+8
Nb-95	1.36E+8
Ru-103	1.09E+8
Ru-106	4.21E+8
Ag-110m	3.47E+9
Te-125m	1.55E+6
Te-127m	9.17E+4
Te-129m	2.00E+7
I-131	1.72E+7
I-132	1.24E+6
I-133	2.47E+6
I-134	4.49E+5
I-135	2.56E+6
Cs-134	6.75E+9
Cs-136	1.49E+8
Cs-137	1.04E+10
Ba-140	2.05E+7
Ce-141	1.36E+7
Ce-144	6.95E+7
Pr-143	-
Nd-147	8.40E+6

APPENDIX A
Evaluation of Default Parameters
for Liquid Effluents

Appendix A
Evaluation of Default Parameters
for Liquid Effluents

A. Effective Maximum Permissible Concentration (MPC_e)

In accordance with the requirements of Technical Specification (3.3.3.8) the radioactive liquid effluent monitors shall be operable with alarm setpoints established to ensure that the concentration of radioactive material at the discharge point does not exceed the MPC value of 10 CFR 20, Appendix B, Table II, Column 2. The determination of allowable radionuclide concentration and corresponding alarm setpoint is a function of the individual radionuclide distribution and corresponding MPC values.

In order to limit the need for routinely having to reestablish the alarm setpoints as a function of changing radionuclide distributions, a default alarm setpoint can be established. This default setpoint can be based on an evaluation of the radionuclide distribution of the liquid effluents from Salem and the effective MPC value for this distribution.

The effective MPC value for a radionuclide distribution is calculated by the equation:

$$MPC_e = \frac{\sum C_i}{\sum \frac{C_i}{MPC_i}} \quad (A.1)$$

where:

- MPC_e = an effective MPC value for a mixture of radionuclide (uCi/ml)
 C_i = concentration of radionuclide i in the mixture
 MPC_i = the 10 CFR 20, Appendix B, Table II, Column 2 MPC value for radionuclide i (uCi/ml)

The equation for determining the liquid effluent setpoints (Section 1.2.1, equation 1.2) is based on a multiplication of the effective MPC times the monitor sensitivity. Considering the average effective MPC value for the years 1992 through 1994, it is reasonable to select an MPC_e value of 6.05E-06 uCi/ml for Unit 1 and 4.81E-06 uCi/ml for Unit 2 as typical of liquid radwaste discharges.

B. Safety Factor

The type of radiation detector used to monitor radioactive releases is not capable of detecting non-gamma emitting radionuclides such as H-3, Fe-55, and Sr-89,90, as required by Technical Specification 3.11.1.1. A conservative default safety factor can be determined to account for non-gamma emitting radionuclides. Non-gamma emitting radionuclides are analyzed at Salem station on a monthly or quarterly basis from a composite sample of liquid releases.

Nuclide	MPC (uci/ml)	Activity (uci/ml)	Activity / MPC
H-3	3E-3	5.2E-1	173.3
Fe-55	8E-4	2.5E-3	3.1
Sr-89	3E-6	2.0E-5	6.7
Sr-90	3E-7	7.2E-7	2.4
Total			185.5

The values in the table above represent the maximum reactor coolant values for non-gamma emitting nuclides in 1994 for Unit 1 and 2. Reactor coolant values were chosen to represent the maximum concentration of non-gamma emitting nuclides that could be released from Salem Station. The activity values in the table will be diluted by a minimum factor of 800 prior to release. The minimum dilution factor is obtained by using the minimum circulating water flowrate of 100,000 gpm and the maximum release rate of 120 gpm.

A conservative non-gamma factor for non-gamma emitting nuclides can be obtained using the highest Activity/MPC fraction and the minimum dilution factor as follows:

$$\text{Non-Gamma Factor} = 185.5 / 800 = 0.23 \text{ (Rounded up to 0.25)}$$

$$\text{Safety Factor} = 1 - 0.25 = 0.75$$

C. Default setpoint determination:

Using the information and parameters described above a default setpoint can be calculated for Unit 1 and 2 liquid radwaste disposal process radiation monitors (R18).

Using these values to calculate the default R18 alarm setpoint value, results in a setpoint that:

- 1) Will not require frequent re-adjustment due to minor variations in the nuclide distribution which are typical of routine plant operations, and
- 2) Will provide for a liquid radwaste discharge rate (as evaluated for each batch release) that is compatible with plant operations (refer to Tables 1-1 and 1-2).

Table A-1
Calculation of Effective MPC
Salem Unit 1

Nuclide	MPC* (uCi/ml)	Activity Released (Ci)		
		1992 CURIES	1993 CURIES	1994 CURIES
Be-7	2E-03	8.74E-05	8.88E-04	N/D
Na-24	3E-05	3.99E-04	6.68E-04	1.62E-04
Cr-51	2E-03	4.30E-03	5.38E-03	2.02E-03
Mn-54	1E-04	7.24E-02	3.52E-02	1.37E-02
Fe-59	5E-05	1.20E-04	4.76E-04	4.84E-03
Co-57	4E-04	1.26E-02	1.03E-02	3.10E-03
Co-58	9E-05	2.33E+00	1.71E+00	6.47E-01
Co-60	3E-05	2.52E-01	3.04E-01	1.10E-01
Zr-95	6E-05	2.90E-03	3.29E-03	7.13E-04
Nb-95	1E-04	6.37E-03	5.78E-03	1.28E-03
Nb-97	9E-04	3.99E-04	1.27E-03	1.07E-03
Tc-99m	3E-03	8.23E-05	2.66E-04	N/D
Sr-92	6E-05	N/D	N/D	7.32E-06
Mo-99	4E-05	N/D	1.76E-04	1.76E-04
Ag-110m	3E-05	8.38E-03	1.19E-02	1.10E-02
Sn-113	8E-05	3.91E-04	7.88E-05	4.91E-05
Sb-122	3E-05	8.54E-05	1.21E-03	5.35E-04
Sb-124	2E-05	1.37E-02	2.08E-02	1.75E-02
Sb-125	1E-04	7.27E-02	9.04E-02	8.23E-02
Sb-126	3E-06	N/D	N/D	6.18E-05
I-131	3E-07	3.06E-02	1.27E-01	1.82E-02
I-133	1E-06	1.75E-03	2.16E-03	1.88E-04
I-134	2E-05	N/D	N/D	3.63E-04
Ce-141	9E-05	3.69E-05	N/D	4.24E-05
Ce-143	4E-05	N/D	5.42E-05	N/D
Cs-134	9E-06	1.64E-01	3.54E-01	6.46E-01
Cs-136	6E-05	1.20E-03	3.61E-03	1.59E-03
Cs-137	2E-05	1.86E-01	4.53E-01	8.54E-01
Cs-138	3E-06	N/D	4.15E-06	1.35E-04
Ba-140	2E-05	N/D	N/D	8.62E-05
La-140	2E-05	6.26E-05	2.12E-04	1.86E-04
Ru-105	1E-04	4.58E-04	2.21E-04	1.35E-04
Ru-106	1E-05	N/D	N/D	1.03E-03
Zn-65	1E-04	8.75E-04	6.72E-04	N/D
Total C ₁ Gamma		3.16E+00	3.14E+00	2.42E+00
MPC _e (uCi/ml)		1.88E-05	6.05E-06	1.28E-05

* MPC value for unrestricted area from 10 CFR 20, Appendix B, Table II, Column 2.

** N/D - not detected

Table A-2
Calculation of Effective MPC
Salem Unit 2

Nuclide	MPC ¹ (uCi/ml)	Activity Released (Ci)		
		1992 CURIES	1993 CURIES	1994 CURIES
Be-7	2E-03	2.20E-04	1.59E-03	2.88E-04
Na-24	3E-05	7.33E-04	1.05E-03	5.77E-05
Cr-51	2E-03	4.13E-03	4.39E-03	1.55E-03
Mn-54	1E-04	9.15E-02	3.73E-02	1.37E-02
Fe-59	5E-05	1.61E-04	4.83E-04	3.25E-03
Co-57	4E-04	1.42E-02	1.17E-02	3.24E-03
Co-58	9E-05	2.57E+00	1.75E+00	6.60E-01
Co-60	3E-05	2.61E-01	3.47E-01	1.03E-01
Zr-95	6E-05	2.06E-03	2.34E-03	3.22E-04
Nb-95	1E-04	5.35E-03	3.97E-03	1.11E-03
Nb-97	9E-04	9.37E-04	1.46E-03	1.10E-03
Tc-99m	3E-03	2.75E-04	3.77E-04	N/D
Mo-99	4E-05	2.28E-04	N/D	N/D
Ag-110m	3E-05	6.07E-03	1.03E-02	1.34E-02
Sn-113	8E-05	8.51E-05	7.45E-05	N/D
Sb-122	3E-05	1.12E-04	1.20E-03	N/D
Sb-124	2E-05	1.20E-02	3.77E-02	9.82E-03
Sb-125	1E-04	8.29E-02	1.35E-01	6.03E-02
Sb-126	3E-06	1.83E-05	3.51E-04	N/D
I-131	3E-07	4.35E-02	1.87E-01	7.98E-03
I-132	8E-06	N/D	8.72E-05	N/D
I-133	1E-06	2.16E-03	2.39E-03	1.85E-04
Ce-141	9E-05	N/D	N/D	2.87E-05
Ce-143	4E-05	2.44E-04	N/D	N/D
Cs-134	9E-06	2.32E-01	4.57E-01	6.44E-01
Cs-136	6E-05	1.82E-03	4.82E-03	1.51E-03
Cs-137	2E-05	2.34E-01	5.70E-01	8.54E-01
Cs-138	3E-06	4.73E-05	N/D	N/D
Ru-106	1E-05	N/D	N/D	4.38E-04
Ru-105	1E-04	2.78E-04	4.07E-05	N/D
La-140	2E-05	6.51E-05	2.03E-03	1.11E-04
W-187	6E-05	N/D	N/D	7.98E-05
Zn-65	1E-04	1.38E-03	1.59E-04	N/D
Sr-92	6E-05	N/D	N/D	1.43E-05
Total C _i	Gamma	3.57E+00	3.57E+00	2.38E+00
MPC _e (uCi/ml)		1.59E-05	4.81E-06	1.55E-05

¹ MPC value for unrestricted area from 10 CFR 20, Appendix B, Table II, Column 2.

** N/D - not detected

APPENDIX B

Technical Basis for Effective Dose Factors

Liquid Radioactive Effluent

APPENDIX B

Technical Basis for Effective Dose Factors -
Liquid Effluent Releases

The radioactive liquid effluents for the years 1992 through 1994 were evaluated to determine the dose contribution of the radionuclide distribution. This analysis was performed to evaluate the use of a limited dose analysis for determining environmental doses, providing a simplified method of determining compliance with the dose limits of Technical Specification 3.11.1.2.

For the radionuclide distribution of effluents from Salem, the controlling organ is the GI-LLI. For the last three years the calculated GI-LLI dose is predominately a function of the Fe-55, Co-58, Co-60, Fe-59 and Ag-110m releases. The radionuclides, Cs-134 and Cs-137 contribute the large majority of the calculated total body dose. The results of the evaluation for 1992, 1993, and 1994 are presented in Table B-1 and Table B-2.

For purposes of simplifying the details of the dose calculational process, it is conservative to identify a controlling, dose significant radionuclide and limit the calculation process to the use of the dose conversion factor for this nuclide. Multiplication of the total release (i.e., cumulative activity for all radionuclides) by this dose conversion factor provides for a dose calculation method that is simplified while also being conservative. For the evaluation of the maximum organ dose, it is conservative to use the Nb-95 dose conversion factor ($1.51 \text{ E}+06$ mrem/hr per uCi/ml, GI-LLI). By this approach, the maximum organ dose will be overestimated since this nuclide has the highest organ dose factor of all the radionuclides evaluated.

For the total body calculation, the Fe-59 dose factor ($2.32 \text{ E}+05$ mrem/hr per uCi/ml, total body) is the highest among the identified dominant nuclides. For evaluating compliance with the dose limits of Technical Specification 3.11.1.2, the following simplified equations may be used:

Total Body

$$D_{tb} = \frac{1.67E-02 * VOL}{CW} * A_{Fe-59, TB} * \sum C_i \quad (B.1)$$

where:

D_{tb} = dose to the total body (mrem)
 $A_{Fe-59, TB}$ = 7.27E+04, total body ingestion dose conversion factor for Fe-59 (mrem/hr per uCi/ml)
 VOL = volume of liquid effluent released (gal)
 C_i = total concentration of all radionuclides (uCi/ml)
 CW = average circulating water discharge rate during release period (gal/min)
 1.67E-02 = conversion factor (hr/min)

Substituting the value for the Fe-59 total body dose conversion factor, the equation simplifies to:

$$D_{tb} = \frac{1.21E+03 * VOL}{CW} * \sum C_i \quad (B.2)$$

Maximum Organ

$$D_{max} = \frac{1.67E-02 * VOL * A_{Nb-95, GI-LLI}}{CW} * \sum C_i \quad (B.3)$$

where:

D_{max} = maximum organ dose (mrem)
 $A_{Nb-95, GI-LLI}$ = 1.51E+06, GI-LLI ingestion dose conversion factor for Nb-95 (mrem/hr per uCi/ml)

Substituting the value for $A_{Nb-95, GI-LLI}$ the equation simplifies to:

$$D_{max} = \frac{2.52E+04 * VOL}{CW} * \sum C_i \quad (B.4)$$

Tritium is not included in the limited analysis dose assessment for liquid releases, because the potential dose resulting from normal reactor releases is relatively negligible. The average annual tritium release from each Salem Unit is approximately 350 curies. The calculated total body dose from such a release is 2.4E-03 mrem/yr via the fish and invertebrate ingestion pathways. This amounts to 0.08% of the design objective dose of 3 mrem/yr. Furthermore, the release of tritium is a function of operating time and power level and is essentially unrelated to radwaste system operation.

Table B-1
Adult Dose Contributions
Fish and Invertebrate Pathways
Unit 1

Nuclide	Release (Ci)			T.Body Dose Fraction			GI-LLI Dose Fraction			Liver Dose Fraction		
	1994	1993	1992	1994	1993	1992	1994	1993	1992	1994	1993	1992
Mn-54	1.32E-2	3.51E-2	7.23E-2	*	*	0.01	0.01	0.03	0.01	*	0.02	0.04
Fe-55	1.49E-1	6.40E-2	1.10E-1	0.07	0.06	0.11	0.11	0.03	0.03	0.20	0.19	0.35
Fe-59	4.84E-3	4.77E-4	N/D	0.02	*	*	0.12	0.01	*	0.04	0.01	*
Co-58	6.47E-1	1.71E+0	2.33E+0	0.05	0.19	0.34	0.27	0.42	0.50	0.01	0.07	0.12
Co-60	1.10E-1	3.04E-1	2.51E-1	0.02	0.09	0.11	0.12	0.19	0.15	0.01	0.03	0.04
Zn-65	0.00E+0	6.72E-4	8.75E-4	*	0.01	0.02	*	*	0.01	*	0.02	0.04
Nb-95	1.28E-3	5.78E-3	6.37E-3	*	*	*	0.07	0.17	0.17	*	*	*
Ag-110m	1.10E-2	1.19E-2	8.35E-3	*	*	*	0.26	0.15	0.09	*	*	*
Cs-134	6.46E-1	3.54E-1	1.64E-1	0.47	0.35	0.24	*	*	*	0.37	0.34	0.22
Cs-137	8.54E-1	4.53E-1	1.86E-1	0.36	0.27	0.16	*	*	*	0.36	0.32	0.18
Total	2.44E+0	2.94E+0	3.13E+0									

Table B-2
Adult Dose Contributions
Fish and Invertebrate Pathways
Unit 2

Nuclide	Release (Ci)			T.Body Dose Fraction			GI-LLI Dose Fraction			Liver Dose Fraction		
	1994	1993	1992	1994	1993	1992	1994	1993	1992	1994	1993	1992
Mn-54	1.37E-2	3.73E-2	8.92E-2	*	*	0.01	0.01	0.01	0.03	*	0.01	0.05
Fe-55	1.38E-1	6.61E-2	6.14E-2	0.06	0.04	0.05	0.10	0.03	0.02	0.18	0.14	0.18
Fe-59	3.25E-3	4.82E-4	N/D	0.01	*	*	0.08	0.01	*	0.02	0.01	*
Co-58	6.60E-1	1.75E+0	2.47E+0	0.05	0.16	0.35	0.29	0.42	0.57	0.01	0.06	0.13
Co-60	1.03E-1	3.47E-1	2.58E-1	0.02	0.09	0.10	0.12	0.22	0.15	0.01	0.03	0.04
Zn-65	0.00E+0	1.59E-4	1.38E-3	*	*	0.04	*	*	0.01	*	0.01	0.07
Nb-95	1.11E-3	3.97E-3	5.35E-3	*	*	*	0.06	0.13	0.14	*	*	*
Ag-110m	1.34E-2	1.03E-2	6.12E-3	*	*	*	0.31	0.15	0.06	*	*	*
Cs-134	6.44E-1	4.58E-1	2.31E-1	0.47	0.40	0.28	0.01	*	*	0.39	0.38	0.30
Cs-137	8.54E-1	4.53E-1	1.86E-1	0.36	0.27	0.16	*	*	*	0.36	0.32	0.18
Total	2.44E+0	2.94E+0	3.13E+0									

* Less than 0.01
N/D = not detected

APPENDIX C

Technical Bases for Effective Dose Factors
Gaseous Radioactive Effluent

APPENDIX C
 Technical Bases for Effective Dose Factors -
 Gaseous Radioactive Effluents

Overview

The evaluation of doses due to releases of radioactive material to the atmosphere can be simplified by the use of effective dose transfer factors instead of using dose factors which are radionuclide specific.

These effective factors, which can be based on typical radionuclide distributions of releases, can be applied to the total radioactivity released to approximate the dose in the environment (i.e., instead of having to perform individual radionuclide dose analyses only a single multiplication (K_{eff} , M_{eff} or N_{eff}) times the total quantity of radioactive material released would be needed).

This approach provides a reasonable estimate of the actual dose while eliminating the need for a detailed calculational technique.

Determination of Effective Dose Factors

Effective dose transfer factors are calculated by the following equations:

$$K_{eff} = \sum (K_i * f_i) \quad (C.1)$$

where:

- K_{eff} = the effective total body dose factor due to gamma emissions from all noble gases released
 K_i = the total body dose factor due to gamma emissions from each noble gas radionuclide i released
 f_i = the fractional abundance of noble gas radionuclide i relative to the total noble gas activity

$$(L + 1.1 M)_{eff} = \sum ((L_i + 1.1 M_i) * f_i) \quad (C.2)$$

where:

- $(L + 1.1 M)_{eff}$ = the effective skin dose factor due to beta and gamma emissions from all noble gases released
 $(L_i + 1.1 M_i)$ = the skin dose factor due to beta and gamma emissions from each noble gas radionuclide i released

$$M_{eff} = \sum (M_i * f_i) \quad (C.3)$$

where:

- M_{eff} = the effective air dose factor due to gamma emissions from all noble gases released
 M_i = the air dose factor due to gamma emissions from each noble gas radionuclide i released

$$N_{eff} = \sum (N_i * f_i) \quad (C.4)$$

where:

- N_{eff} = the effective air dose factor due to beta emissions from all noble gases released
 N_i = the air dose factor due to beta emissions from each noble gas radionuclide i released

Normally, it would be expected that past radioactive effluent data would be used for the determination of the effective dose factors. However, the noble gas releases from Salem have been maintained to such negligible quantities that the inherent variability in the data makes any meaningful evaluations difficult. For the past years, the total noble gas releases have been limited to 950 Ci for 1992, 1000 Ci for 1993, and 950 Ci for 1994.

Therefore, in order to provide a reasonable basis for the derivation of the effective noble gas dose factors, the primary coolant source term from ANSI N237-1976/ANS-18.1, "Source Term Specifications," has been used as representing a typical distribution. The effective dose factors as derived are presented in Table C-1.

Application

To provide an additional degree of conservatism, a factor of 0.50 is introduced into the dose calculational process when the effective dose transfer factor is used. This conservatism provides additional assurance that the evaluation of doses by the use of a single effective factor will not significantly underestimate any actual doses in the environment.

For evaluating compliance with the dose limits of Technical Specification 3.11.2.2, the following simplified equations may be used:

$$D_g = \frac{3.17E-08}{0.50} * X/Q * M_{eff} * \sum Q_i \quad (C.5)$$

and

$$D_b = \frac{3.17E-08}{0.50} * X/Q * N_{eff} * \sum Q_i \quad (C.6)$$

where:

D_g	= air dose due to gamma emissions for the cumulative release of all noble gases (mrad)
D_b	= air dose due to beta emissions for the cumulative release of all noble gases (mrad)
X/Q	= atmospheric dispersion to the controlling site boundary (sec/m ³)
M_{eff}	= 5.3E+02, effective gamma-air dose factor (mrad/yr per uCi/m ³)
N_{eff}	= 1.1E+03, effective beta-air dose factor (mrad/yr per uCi/m ³)
Q_i	= cumulative release for all noble gas radionuclides (uCi)
3.17E-08	= conversion factor (yr/sec)
0.50	= conservatism factor to account for the variability in the effluent data

Combining the constants, the dose calculational equations simplify to:

$$D_g = 3.5E-05 * X/Q * \sum Q_i \quad (C.7)$$

and

$$D_b = 7.0E-05 * X/Q * \sum Q_i \quad (C.8)$$

The effective dose factors are used on a very limited basis for the purpose of facilitating the timely assessment of radioactive effluent releases, particularly during periods of computer malfunction where a detailed dose assessment may be unavailable.

Table C-1

Effective Dose Factors

Noble Gases - Total Body and Skin

Radionuclide	f_1^*	Total Body Effective Dose Factor K_{eff} (mrem/yr per uCi/m ³)	Skin Effective Dose Factor (L+ 1.1 M) N_{eff} (mrem/yr per uCi/m ³)
Kr-85	0.01	--	1.4E+01
Kr-88	0.01	1.5E+02	1.9E+02
Xe-133m	0.01	2.5E+00	1.4E+01
Xe-133	0.95	2.8E+02	6.6E+02
Xe-135	0.02	3.6E+01	7.9E+01
Total		4.7E+02	9.6E+02

Noble Gases - Air

Radionuclide	f_1^*	Gamma Air Effective Dose Factor M_{eff} (mrad/yr per uCi/m ³)	Beta Air Effective Dose Factor N_{eff} (mrad/yr per uCi/m ³)
Kr-85	0.01	--	2.0E+01
Kr-88	0.01	1.5E+02	2.9E+01
Xe-133m	0.01	3.3E+00	1.5E+01
Xe-133	0.95	3.4E+02	1.0E+03
Xe-135	0.02	3.8E+01	4.9E+01
Total		5.3E+02	1.1E+03

* Based on Noble gas distribution from ANSI N237-1976/ANSI-18.1, "Source Term Specifications."

APPENDIX D

Technical Basis for Effective Dose Parameter

Gaseous Radioactive Effluent

APPENDIX D

**Technical Basis for Effective Dose Parameter
Gaseous Radioactive Effluent Releases**

The pathway dose factors for the controlling infant age group were evaluated to determine the controlling pathway, organ and radionuclide. This analysis was performed to provide a simplified method for determining compliance with Technical Specification 3.11.2.3

For the infant age group, the controlling pathway is the grass-cow-milk (g/c/m) pathway. An infant receives a greater radiation dose from the g/c/m pathway than any other pathway. Of this g/c/m pathway, the maximum exposed organ including the total body, is the thyroid, and the highest dose contributor is radionuclide I-131. The results for this evaluation are presented in Table D-1.

For purposes of simplifying the details of the dose calculation process, it is conservative to identify a controlling, dose significant organ and radionuclide and limit the calculation process to the use of the dose conversion factor for the organ and radionuclide. Multiplication of the total release (i.e. cumulative activity for all radionuclides) by this dose conversion factor provides for a dose calculation method that is simplified while also being conservative.

For the evaluation of the dose commitment via a controlling pathway and age group, it is conservative to use the infant, g/c/m, thyroid, I-131 pathway dose factor (1.05E12 m² mrem/yr per uCi/sec). By this approach, the maximum dose commitment will be overestimated since I-131 has the highest pathway dose factor of all radionuclides evaluated.

For evaluating compliance with the dose limits of Technical Specification 3.11.2.3, the following simplified equation may be used:

$$D_{\max} = 3.17E-8 * W * RI-131 * \sum Q_i$$

where:

- D_{\max} = maximum organ dose (mrem)
- W = atmospheric dispersion parameters to the controlling location(s) as identified in Table 3.2-4.
- X/Q = atmospheric dispersion for inhalation pathway and H-3 dose contribution via other pathways (sec/m³)
- D/Q = atmospheric deposition for vegetation, milk and ground plane exposure pathways (m⁻²)
- Q_i = cumulative release over the period of interest for radioiodines and particulates
- 3.17E-8 = conversion factor (yr/sec)

- RI-131 = I-131 dose parameter for the thyroid for the identified controlling pathway
= $1.05E12$ (m^2 mrem/yr per uCi/sec), infant thyroid dose parameter with the grass-cow-milk pathway controlling

The ground plane exposure and inhalation pathways need not be considered when the above simplified calculation method is used because for the overall negligible contribution of these pathways to the total thyroid dose.

It is recognized that for some particulate radionuclides (e.g., Co-60 and Cs-137), the ground exposure pathway may represent a higher dose contribution than either the vegetation or milk pathway. However, use of the I-131 thyroid dose parameter for all radionuclides will maximize the organ dose calculation, especially considering that no other radionuclide has a higher dose parameter for any organ via any pathway than I-131 for the thyroid via the milk pathway (see Table D-1).

The location of exposure pathways and the maximum organ calculation may be based on the available pathways in the surrounding environment of Salem as identified by the annual land-use census (Technical Specification 3.12.2). Otherwise, the dose will be evaluated based on the predetermined controlling pathways as identified in Table 2-4.

Table D-1
 Infant Dose Contributions
 Fraction of Total Organ and Body Dose

<u>PATHWAYS</u>		
<u>Target Organs</u>	<u>Grass-Cow-Milk</u>	<u>Ground Plane</u>
Total Body	0.02	0.15
Liver	0.23	0.14
Thyroid	0.59	0.15
Kidney	0.02	0.15
Lung	0.01	0.02
GI-LLI	0.02	0.15

Fraction of Dose Contribution by Pathway

<u>Pathway</u>	<u>f</u>
Grass-Cow-Milk	0.92
Ground Plane	0.08
Inhalation	*

APPENDIX E

Radiological Environmental Monitoring Program

Sample Type, Location and Analysis

APPENDIX E

SAMPLE DESIGNATION

Samples are identified by a three part code. The first two letters are the power station identification code, in this case "SA". The next three letters are for the media sampled.

AIO = Air Iodine	IDM = Immersion Dose (TLD)
APT = Air Particulates	MLK = Milk
ECH = Hard Shell Blue Crab	PWR = Potable Water (Raw)
ESF = Edible Fish	PWT = Potable Water (Treated)
ESS = Sediment	SWA = Surface Water
WWA = Well Water	

The last four symbols are a location code based on direction and distance from the site. Of these, the first two represent each of the sixteen angular sectors of 22.5 degrees centered about the reactor site. Sector one is divided evenly by the north axis and other sectors are numbered in a clockwise direction; i.e., 2=NNE, 3=NE, 4=ENG, etc. The next digit is a letter which represents the radial distance from the plant:

S = On-site location	E = 4-5 miles off-site
A = 0-1 miles off-site	F = 5-10 miles off-site
B = 1-2 miles off-site	G = 10-20 miles off-site
C = 2-3 miles off-site	H = > 20 miles off-site
D = 3-4 miles off-site	

The last number is the station numerical designation within each sector and zone; e.g., 1,2,3,... For example; the designation SA-WWA-5D1 would indicate a sample in the SGS program (SA), consisting of well water (WWA), which had been collected in sector number 5, centered at 90' (due east) with respect to the reactor site at a radial distance of 3 to 4 miles off-site, (therefore, radial distance D). The number 1 indicated that this is sampling station #1 in that particular sector.

SAMPLING LOCATIONS

All sampling locations and specific information about the individual locations are given in Table E-1. Maps E-1 and E-2 show the locations of sampling stations with respect to the site.

TABLE E-1

A. Direct Radiation Monitoring Locations (IDM)

<u>STATION CODE</u>	<u>STATION LOCATION</u>
1S1	0.55 mi. N of vent
2S2	0.4 mi. NNE of vent
2S4	0.59 mi. NNE of vent
3S1	0.58 mi. NE of vent
4S1	0.60 mi. ENE of vent
5S1	1.0 mi. E of vent; site access road
6S2	0.21 mi. ESE of vent; observation building
** 7S1	0.12 mi. SE of vent; station personnel gate
** 10S1	0.14 mi. SSW of vent; circ water bldg.
** 11S1	0.09 mi. SW of vent; service water bldg.
15S1	0.57 mi. NW of vent
16S1	0.54 mi. NNW of vent
4D2	3.7 mi. ENE of vent; Alloway Creek Neck Road
5D1	3.5 mi. E of vent; local farm
10D1	3.9 mi. SSW of vent; Taylor's Bridge Spur
14D1	3.4 mi. WNW of vent; Bay View, Delaware
15D1	3.8 mi. NW of vent; Rt 9, Augustine Beach, DE.
2E1	4.4 mi. NNE of vent; local farm
3E1	4.1 mi. NE of vent; local farm
9E1	4.2 mi. S of vent
11E2	5.0 mi. SW of vent
12E1	4.4 mi. WSW of vent; Thomas Landing
13E1	4.2 mi. W of vent; Diehl House Lab
16E1	4.1 mi. NNW of vent; Port Penn
1F1	5.8 mi. N of vent; Fort Elfsborg
2F2	8.7 mi. NNE of vent; Salem Substation
2F5	7.4 mi. NNE of vent; Salem High School
2F6	7.3 mi. NNE of vent; PSE&G Training Center
3F2	5.1 mi. NE of vent; Hancocks Bridge Munc. Bldg
3F3	8.6 mi. NE of vent; Quinton Township School
4F2	6.0 mi. ENE of vent; Mays Lane, Harmersville
5F1	6.5 mi. E of vent; Canton
6F1	6.4 mi. ESE of vent; Stow Neck Road
7F2	9.1 mi. SE of vent; Bayside, NJ
10F2	5.8 mi. SSW of vent; Rt. 9
11F1	6.2 mi. SW of vent; Taylors Bridge, DE.
12F1	9.4 mi. WSW of vent; Townsend Elementary School
13F2	6.5 mi. W of vent; Odessa, DE.
13F3	9.3 mi. W of vent; Redding Middle School
13F4	9.8 mi. W of vent; Middletown, DE.
14F2	6.6 mi. WNW of vent; Boyds Corner
15F3	5.4 mi. NW of vent
16F2	8.1 mi. NNW of vent; Delaware City Public School

TABLE E-1 (Cont'd)

A. Direct Radiation Monitoring Locations (IDM) (Cont'd)

<u>STATION CODE</u>	<u>STATION LOCATION</u>
1G3	19 mi. N of vent; N. Church St. Wilmington, DE
3G1	17 mi. NE of vent; local farm
10G1	12 mi. SSW of vent; Smyrna, Delaware
16G1	15 mi. NNW of vent; Wilmington Airport
3H1	32 mi. NE of vent; National Park, NJ
3H3	110 mi. NE of vent; Maplewood R&TL

** TLD locations will be maintained by site area monitoring program

B. Air Sampling Locations (AIO, APT)

<u>STATION CODE</u>	<u>STATION LOCATION</u>
5S1	1.0 mi. E of vent; site access road
5D1	3.5 mi. E of vent; local farm
16E1	4.1 mi. NNW of vent; Port Penn
1F1	5.8 mi. N of vent; Fort Elfsborg
2F6	7.3 mi. NNE of vent; PSE&G Training Center
14G1	11.8 mi. WNW of vent; Rte. 286, Bethel Church Road, Delaware

C. Surface Water Locations (SWA) - Delaware River

<u>STATION CODE</u>	<u>STATION LOCATION</u>
11A1	0.2 mi. SW of vent; Salem Outfall Area
12C1	2.5 mi. WSW of vent; West bank of Delaware River
7E1	4.5 mi. SE of vent; Delaware River
16F1	6.9 mi. NNW of vent; C&D Canal

D. Ground Water Locations (WWA)

<u>STATION CODE</u>	<u>STATION LOCATION</u>
---------------------	-------------------------

No public drinking water samples or irrigation water samples are taken as these pathways are not directly affected by liquid effluents discharged from Salem Generating Station.

E. Drinking Water Locations (PWR, PWT)

<u>STATION CODE</u>	<u>STATION LOCATION</u>
---------------------	-------------------------

No public drinking water samples or irrigation water samples are taken as these pathways are not directly affected by liquid effluents discharged from Salem Generating Station.

Table E-1 (Cont'd)

F. Water Sediment Locations (ESS)

<u>STATION CODE</u>	<u>STATION LOCATION</u>
11A1	0.2 mi. SW of vent; Salem outfall area
15A1	0.3 mi. NW of vent; Hope Creek outfall area
16A1	0.7 mi. NNW of vent; South Storm Drain outfall
12C1	2.5 mi. WSW of vent; West bank of Delaware river
7E1	4.5 mi. SE of vent; 1 mi West of Mad Horse River
16F1	5.9 mi. NNW of vent; C&D Canal

G. Milk Sampling Locations (MLK)

<u>STATION CODE</u>	<u>STATION LOCATION</u>
2F7	5.7 mi. NNE of vent; local farm
11F3	5.3 mi. SW of vent; Townsend DE.
14F4	7.6 mi. WNW of vent; local farm
3G1	17 mi. NE of vent; local farm

H. Fish and Invertebrate Locations (ESF,ECH)

<u>STATION CODE</u>	<u>STATION LOCATION</u>
11A1	0.2 mi. SW of vent; Salem outfall area
12C1	2.5 mi. WSW of vent; West bank of Delaware River
7E1	4.5 mi. SE of vent; 1 mi West of Mad Horse Creek

I. Food Product Locations

<u>STATION CODE</u>	<u>STATION LOCATION</u>
---------------------	-------------------------

The Delaware River at the location of Salem and Hope Creek Nuclear Power Plants is a brackish water source. No irrigation of food products is performed using water in the vicinity from which liquid plant wastes have been discharged.

SAMPLES COLLECTION AND ANALYSIS

<u>Sample</u>	<u>Collection Method</u>	<u>Analysis</u>
Air Particulate	Continuous low volume air sampler. Sample collected every week along with the filter change.	Gross Beta analysis on each weekly sample. Gamma spectrometry shall be performed if gross beta exceeds 10 times the yearly mean of the control station value. Samples shall be analyzed 24 hrs or more after collection to allow for radon and thorium daughter decay. Gamma isotopic analysis on quarterly composites.
Air Iodine	A TEDA impregnated charcoal cartridge is connected to air particulate air sampler and is collected weekly at filter change.	Iodine 131 analysis are performed on each weekly sample.
Crab and Fish	Two batch samples are sealed in a plastic bag or jar and frozen semi-annually or when in season.	Gamma isotopic analysis of edible portion on collection.
Sediment	A sediment sample is taken semi-annually.	Gamma isotopic analysis semi-annually.
Direct	2 TLD's will be collected from each location quarterly.	Gamma dose quarterly.

SAMPLE COLLECTION AND ANALYSIS (Cont'd)

<u>Sample</u>	<u>Collection Method</u>	<u>Analysis</u>
Milk	Sample of fresh milk is collected for each farm semi-monthly when cows are in pasture, monthly at other times.	Gamma isotopic analysis and I-131 analysis on each sample on collection.
Water (Potable, Surface)	Sample to be collected monthly providing winter icing conditions allow.	Gamma isotopic monthly H-3 on quarterly surface sample, monthly on ground water sample.

Figure E-1
ONSITE SAMPLING LOCATIONS

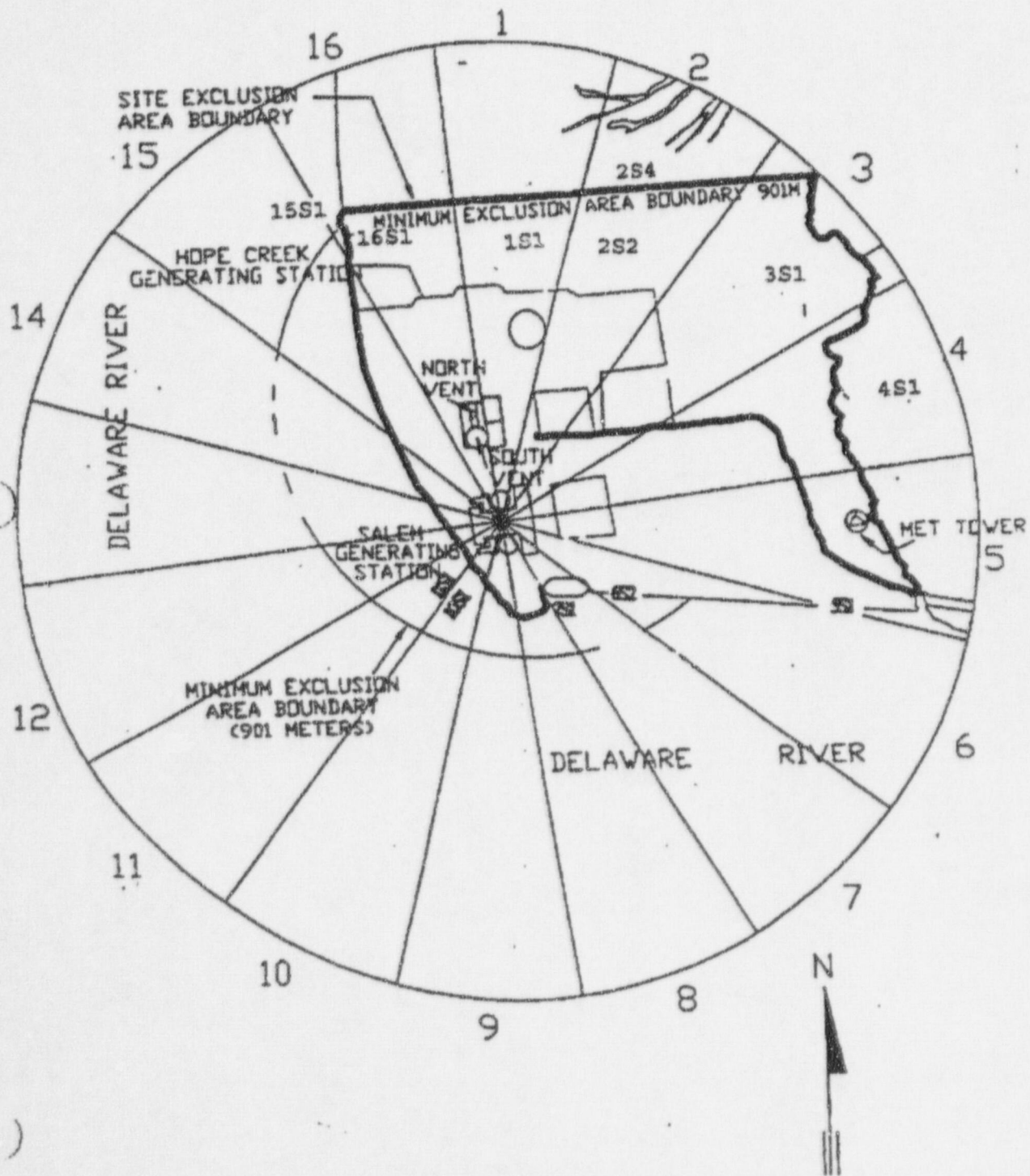

MAP B-2
SALEM AND HOPE CREEK GENERATING STATIONS
RADIOLOGICAL ENVIRONMENTAL MONITORING PROGRAM
OFF-SITE SAMPLING LOCATION

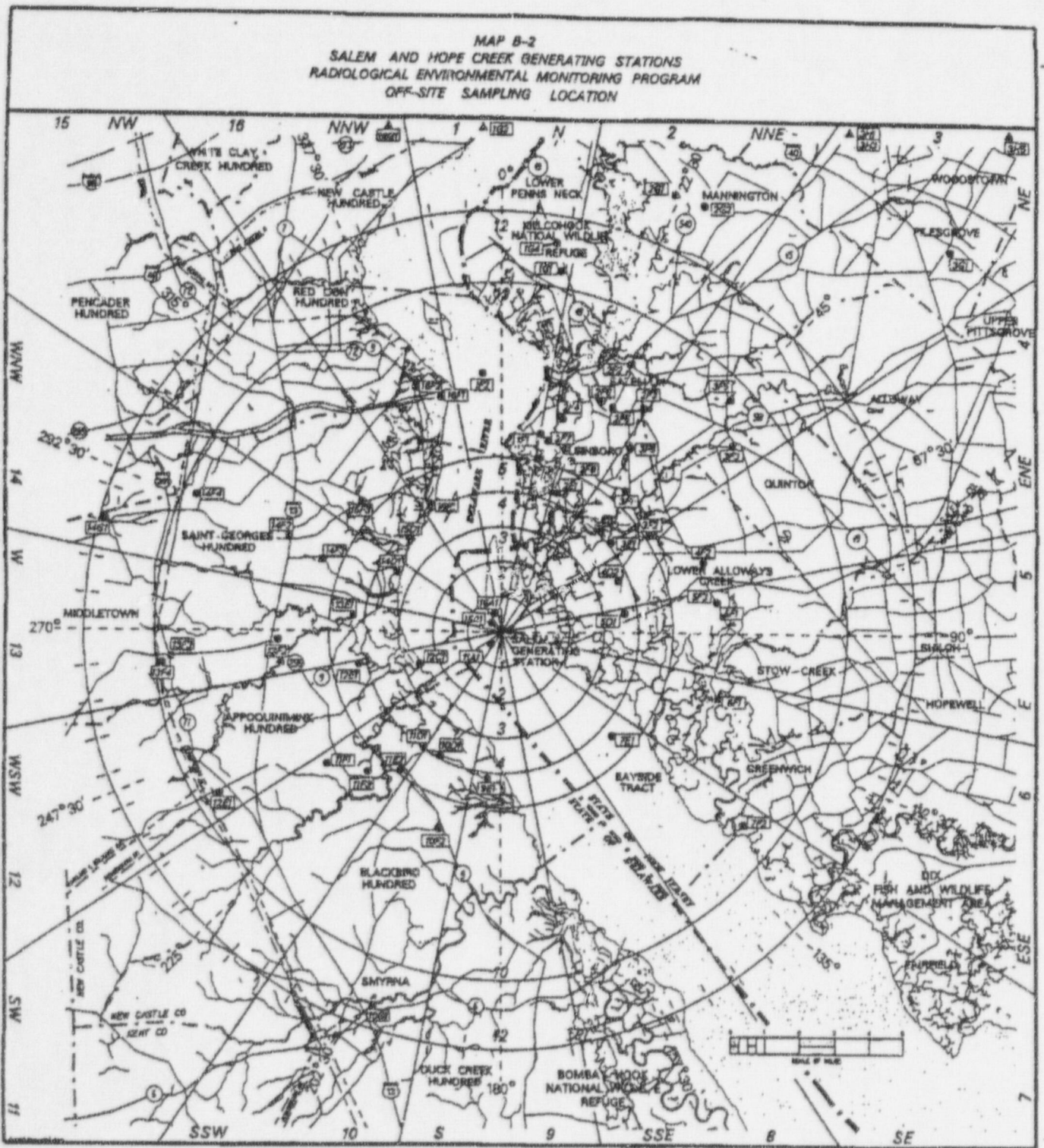

APPENDIX C

MAXIMUM PERMISSIBLE CONCENTRATIONS

LIQUID EFFLUENTS

The following radionuclide concentrations were obtained from 10 CFR 20 Appendix B, Table II, Column 2 as revised January 1, 1991.

Maximum Permissible Concentrations

Element	Isotope	Soluble Conc (uci/ml)	Insoluble Conc. (uci/ml)
Actinium (89)	Ac-227	2E-6	3E-4
	Ac-228	9E-5	9E-5
Americium (95)	Am-241	4E-6	3E-5
	Am-242m	4E-6	9E-5
	Am-242	1E-4	1E-4
	Am-243	4E-6	3E-5
	Am-244	5E-3	5E-3
Antimony (51)	Sb-122	3E-5	3E-5
	Sb-124	2E-5	2E-5
	Sb-125	1E-4	1E-4
Arsenic (33)	As-73	5E-4	5E-4
	As-74	5E-5	5E-5
	As-76	2E-5	2E-5
	As-77	8E-5	8E-5
Astatine (85)	At-211	2E-6	7E-5
Barium (56)	Ba-131	2E-4	2E-4
	Ba-140	3E-5	2E-5
Berkelium (97)	Bk-249	6E-4	6E-4
	Bk-250	2E-4	2E-4
Beryllium (4)	Be-7	2E-3	2E-3
Bismuth (83)	Bi-206	4E-5	4E-5
	Bi-207	6E-5	6E-5
	Bi-210	4E-5	4E-5
	Bi-212	4E-4	4E-4
Bromine (35)	Br-82	3E-4	4E-5
Cadmium (48)	Cd-109	2E-4	2E-4
	Cd-115m	3E-5	3E-5
	Cd-115	3E-5	4E-5
Calcium (20)	Ca-45	9E-6	2E-4
	Ca-47	5E-5	3E-5
Californium (98)	Cf-249	4E-6	2E-5
	Cf-250	1E-5	3E-5
	Cf-251	4E-6	3E-5
	Cf-252	7E-6	7E-6
	Cf-253	1E-4	1E-4
	Cf-254	1E-7	1E-7
Carbon (6)	C-14	8E-4	-----
Cerium (58)	Ce-141	9E-5	9E-5
	Ce-143	4E-5	4E-5

Element	Isotope	Soluble Conc. (uci/ml)	Insoluble Conc. (uci/ml)
	Ce-144	1E-5	1E-5
Cesium (55)	Cs-131	2E-3	9E-4
	Cs-134m	6E-3	1E-3
	Cs-134	9E-6	4E-5
	Cs-135	1E-4	2E-4
	Cs-136	9E-5	6E-5
	Cs-137	2E-5	4E-5
Chlorine (17)	Cl-36	8E-5	6E-5
	Cl-38	4E-4	4E-4
Chromium (24)	Cr-51	2E-3	2E-3
Cobalt (27)	Co-57	5E-4	4E-4
	Co-58m	3E-3	2E-3
	Co-58	1E-4	9E-5
	Co-60	5E-5	3E-5
Copper (29)	Cu-64	3E-4	2E-4
Curium (96)	Cm-242	2E-5	2E-5
	Cm-243	5E-6	2E-5
	Cm-244	7E-6	3E-5
	Cm-245	4E-6	3E-5
	Cm-246	4E-6	3E-5
	Cm-247	4E-6	2E-5
	Cm-248	4E-7	1E-6
	Cm-249	2E-3	2E-3
Dysprosium (66)	Dy-165	4E-4	4E-4
	Dy-166	4E-5	4E-5
Iridium (77)	Ir-190	2E-4	2E-4
	Ir-192	4E-5	4E-5
	Ir-194	3E-5	3E-5
Iron (26)	Fe-55	8E-4	2E-3
	Fe-59	6E-5	5E-5
Lanthanum (57)	La-140	2E-5	2E-5
Einsteinium (99)	Es-253	2E-5	2E-5
	Es-254m	2E-5	2E-5
	Es-254	1E-5	1E-5
	Es-255	3E-5	3E-5
Erbium (68)	Er-169	9E-5	9E-5
	Er-171	1E-4	1E-4
Europium (63)	Eu-152 (9.2 hrs)	6E-5	6E-5
	Eu-152 (13 yrs)	8E-5	8E-5
	Eu-154	2E-5	2E-5
	Eu-155	2E-4	2E-4

Element	Isotope	Soluble Conc. (uci/ml)	Insoluble Conc. (uci/ml)
Fermium (100)	Fm-254	1E-4	1E-4
	Fm-255	3E-5	3E-5
	Fm-256	9E-7	9E-7
Fluorine (9)	F-18	8E-4	5E-4
Gadolinium (64)	Gd-153	2E-4	2E-4
	Gd-159	8E-5	8E-5
Gallium (31)	Ga-72	4E-5	4E-5
Germanium (32)	Ge-71	2E-3	2E-3
Gold (79)	Au-196	2E-4	1E-4
	Au-198	5E-5	5E-5
	Au-199	2E-4	2E-4
Hafnium (72)	Hf-181	7E-5	7E-5
Holmium (67)	Ho-166	3E-5	3E-5
Hydrogen (3)	H-3	3E-3	3E-3
Indium (49)	In-113m	1E-3	1E-3
	In-114m	2E-5	2E-5
	In-115m	4E-4	4E-4
	In-115	9E-5	9E-5
Iodine (53)	I-125	2E-7	2E-4
	I-126	3E-7	9E-5
	I-129	6E-8	2E-4
	I-131	3E-7	6E-5
	I-132	8E-6	2E-4
	I-133	1E-6	4E-5
	I-134	2E-5	6E-4
	I-135	4E-6	7E-5
Lead (82)	Pb-203	4E-4	4E-4
	Pb-210	1E-7	2E-4
	Pb-212	2E-5	2E-5
Lutetium (71)	Lu-177	1E-4	1E-4
Manganese (25)	Mn-52	3E-5	3E-5
	Mn-54	1E-4	1E-4
	Mn-56	1E-4	1E-4
Mercury (80)	Hg-197m	2E-4	2E-4
	Hg-197	3E-4	5E-4
	Hg-203	2E-5	1E-4
Molybdenum (42)	Mo-99	2E-4	4E-5
Neodymium (60)	Nd-144	7E-5	8E-5
	Nd-147	6E-5	6E-5
	Nd-149	3E-4	3E-4
Neptunium (93)	Np-237	3E-6	3E-5
	Np-239	1E-4	1E-4
Nickel (28)	Ni-59	2E-4	2E-3
	Ni-63	3E-5	7E-4

Element	Isotope	Soluble Conc. (uci/ml)	Insoluble Conc. (uci/ml)
	Ni-65	1E-4	1E-4
Niobium (41)	Nb-93m	4E-4	4E-4
	Nb-95	1E-4	1E-4
	Nb-97	9E-4	9E-4
Osmium (76)	Os-185	7E-5	7E-5
	Os-191m	3E-3	2E-3
	Os-191	2E-4	2E-4
	Os-193	6E-5	5E-5
Palladium (46)	Pd-103	3E-4	3E-4
	Pd-109	9E-5	7E-5
Phosphorus (15)	P-32	2E-5	2E-5
Platinum (78)	Pt-191	1E-4	1E-4
	Pt-193m	1E-3	1E-3
	Pt-193	9E-4	2E-3
	Pt-197m	1E-3	9E-4
	Pt-197	1E-4	1E-4
Plutonium (94)	Pu-238	5E-6	3E-5
	Pu-239	5E-6	3E-5
	Pu-240	5E-6	3E-5
	Pu-241	2E-4	1E-3
	Pu-242	5E-6	3E-5
	Pu-243	3E-4	3E-4
Polonium (84)	Po-210	7E-7	3E-5
Potassium (19)	K-42	3E-4	2E-5
Praseodymium (59)	Pr-142	3E-5	3E-5
	Pr-143	5E-5	5E-5
Promethium (61)	Pm-147	2E-4	2E-4
	Pm-149	4E-5	4E-5
Protactinium (91)	Pa-230	2E-4	2E-4
	Pa-231	9E-7	2E-5
	Pa-233	1E-4	1E-4
Radium (88)	Ra-223	7E-7	4E-6
	Ra-224	2E-6	5E-6
	Ra-226	3E-8	3E-5
	Ra-228	3E-8	3E-5
Rhenium (75)	Re-183	6E-4	3E-4
	Re-186	9E-5	5E-5
	Re-187	3E-3	2E-3
	Re-188	6E-5	3E-5
Rhodium (45)	Rh-103m	1E-2	1E-2
	Rh-105	1E-4	1E-4
Rubidium (37)	Rb-86	7E-5	2E-5
	Rb-87	1E-4	2E-4
Ruthenium (44)	Ru-97	4E-4	3E-4
	Ru-103	8E-5	8E-5
	Ru-105	1E-4	1E-4
	Ru-106	1E-5	1E-5

Element	Isotope	Soluble Conc. (uci/ml)	Insoluble Conc. (uci/ml)
Samarium (62)	Sm-147	6E-5	7E-5
	Sm-151	4E-4	4E-4
	Sm-153	8E-5	8E-5
Scandium (21)	Sc-46	4E-5	4E-5
	Sc-47	9E-5	9E-5
	Sc-48	3E-5	3E-5
Selenium (34)	Se-75	3E-4	3E-4
Silicon (14)	Si-31	9E-4	2E-4
Silver (47)	Ag-105	1E-4	1E-4
	Ag-110m	3E-5	3E-5
	Ag-111	4E-5	4E-5
Sodium (11)	Na-22	4E-5	3E-5
	Na-24	2E-4	3E-5
Strontium (38)	Sr-85m	7E-3	7E-3
	Sr-85	1E-4	2E-4
	Sr-89	3E-6	3E-5
	Sr-90	3E-7	4E-5
	Sr-91	7E-5	5E-5
	Sr-92	7E-5	6E-5
Sulfur (16)	S-35	6E-5	3E-4
Tantalum (73)	Ta-182	4E-5	4E-5
Technetium (43)	Tc-96m	1E-2	1E-2
	Tc-96	1E-4	5E-5
	Tc-97m	4E-4	2E-4
	Tc-97	2E-3	8E-4
	Tc-99m	6E-3	3E-3
	Tc-99	3E-4	2E-4
Tellurium (52)	Te-125m	2E-4	1E-4
	Te-127m	6E-5	5E-5
	Te-127	3E-4	2E-4
	Te-129m	3E-5	2E-5
	Te-129	8E-4	8E-4
	Te-131m	6E-5	4E-5
	Te-132	3E-5	2E-5
Terbium (65)	Tb-160	4E-5	4E-5
Thallium (81)	Tl-200	4E-4	2E-4
	Tl-201	3E-4	2E-4
	Tl-202	1E-4	7E-5
	Tl-204	1E-4	6E-5
Thorium (90)	Th-227	2E-5	2E-5
	Th-228	7E-6	1E-5
	Th-230	2E-6	3E-5
	Th-231	2E-4	2E-4
	Th-232	2E-6	4E-5
	Th-natural	2E-6	2E-5
	Th-234	2E-5	2E-5
Thulium (69)	Tm-170	5E-5	5E-5

Element	Isotope	Soluble Conc. (uci/ml)	Insoluble Conc. (uci/ml)
	Tm-171	5E-4	5E-4
Tin (50)	Sn-113	9E-5	8E-5
	Sn-124	2E-5	2E-5
Tungsten (74)	W-181	4E-4	3E-4
	W-185	1E-4	1E-4
	W-187	7E-5	6E-5
Uranium (92)	U-230	5E-6	5E-6
	U-232	3E-5	3E-5
	U-233	3E-5	3E-5
	U-234	3E-5	3E-5
	U-235	3E-5	3E-5
	U-236	3E-5	3E-5
	U-238	4E-5	4E-5
	U-240	3E-5	3E-5
	U-natural	3E-5	3E-5
Vanadium (23)	V-48	3E-5	3E-5
Ytterbium (70)	Yb-175	1E-4	1E-4
Yttrium (39)	Y-90	2E-5	2E-5
	Y-91m	3E-3	3E-3
	Y-91	3E-5	3E-5
	Y-92	6E-5	6E-5
	Y-93	3E-5	3E-5
Zinc (30)	Zn-65	1E-4	2E-4
	Zn-69m	7E-5	6E-5
	Zn-69	2E-3	2E-3
Zirconium (40)	Zr-93	8E-4	8E-4
	Zr-95	6E-5	6E-5
	Zr-97	2E-5	2E-5
Any single radionuclide not listed above with decay mode other than alpha emission or spontaneous fission and with the radioactive half-life greater than two hours.		3E-6	3E-6

Element	Isotope	Soluble Conc. (uci/ml)	Insoluble Conc. (uci/ml)
Any single radionuclide not listed above, which decays by alpha emission or spontaneous fission.		3E-8	3E-8

Notes:

1. If the identity of any radionuclide is not known, the limiting values for the purposes of this table shall be: 3E-8 uci/ml.

2. If the identity and concentration of each radionuclide are known, the limiting values should be derived as follows: Determine, for each radionuclide in the mixture, the ratio between the quantity present in the mixture and the limit otherwise established in Appendix B for the specific radionuclide not in a mixture. The sum of such ratios for all the radionuclides in the mixture may not exceed "1" (i.e. "unity").