

INSPECTION OF THE LICENSEES' IMPLEMENTATION OF INDUSTRY INITIATIVE
ASSOCIATED WITH THE OPEN PHASE CONDITION DESIGN VULNERABILITIES IN
ELECTRIC POWER SYSTEMS (NRC BULLETIN 2012-01)

Effective Date: 08/18/2020

CORNERSTONE: Initiating Events, Mitigating Systems

APPLICABILITY: This Temporary Instruction (TI) applies to the holders of operating licenses for operating nuclear power reactors who have implemented actions to protect against open phase conditions (OPCs). This TI is to be performed at all current operating plants with the exception of Seabrook Station, Unit 1, plants seeking NRC approval in accordance with 10 CFR 50.90, and sites that have informed the NRC of their intent to decommission prior to 01/30/2021.

2515/194-01 OBJECTIVE

01.01 To verify that licensees have appropriately implemented the Nuclear Energy Institute (NEI) voluntary industry initiative (VII), Revision 3, including updating their licensing basis to reflect the need to protect against OPCs.

2515/194-02 BACKGROUND

Event at Byron Nuclear Plant

On January 30, 2012, Byron Station, Unit 2 experienced an automatic reactor trip from full power because the reactor protection scheme detected an undervoltage condition on the 6.9 kilovolt (kV) buses that power reactor coolant pumps (RCPs) B and C (undervoltage on two of four RCPs initiate a reactor trip).

Byron Station is a two-unit pressurized water reactor plant. The electrical distribution system for each unit consists of four non-safety 6.9-kV buses, two non-safety 4 kV buses, and two engineered safety features (ESF) 4-kV station buses. During normal plant operation, the safety (or ESF buses) and non-safety buses (or non-ESF) are powered from the Unit Auxiliary Transformers (UATs). On the day of the event, two non-ESF 6.9-kV station buses that power two of the RCPs and the two 4-kV (ESF and non-ESF) buses were supplied by station auxiliary transformers (SATs) connected to the 345-kV offsite power switchyard (Figure 1 below). The other two 6.9-kV and 4-kV buses were powered from the UATs. The undervoltage condition on the SAT powered buses was caused by a broken inverted porcelain insulator stack of the phase C conductor for the 345-kV power circuit that supplies both SATs. The insulator failure caused the associated phase C conductor to break off from the power line disconnect switch resulting in a high impedance ground fault through the fallen phase C conductor and a sustained open phase condition (OPC) on the high voltage side of the SAT. The open circuit created an

unbalanced voltage condition on the two 6.9-kV non-ESF RCP buses and the two 4.16-kV (ESF and non-ESF) buses. After the reactor trip and subsequent generator trip, the two 6.9 kV buses, which were aligned to the UATs, automatically transferred to the SATs, as designed. As a result of the open circuit on C phase, the load current in phases A and B increased and caused the remaining two operating RCPs to trip on phase overcurrent. In the absence of any operating RCPs, control room operators performed a natural-circulation cooldown of the plant.

The SATs continued to power the 4.16 kV ESF buses A and B because of a design vulnerability that did not isolate the safety related buses from the degraded offsite power system. Some ESF loads that were energized relied on equipment protective devices to prevent damage from an unbalanced overcurrent condition. The phase overcurrent condition caused by the OPC actuated relays to trip several ESF loads.

Approximately 8 minutes after the reactor trip, the control room operators diagnosed the loss of the phase C condition and manually tripped circuit breakers to separate the unit buses from the offsite power source. When the operators opened the SAT feeder breakers to the redundant 4.16-kV ESF buses, the loss of voltage relays started the emergency diesel generators (EDGs) and restored power to the ESF buses. If the condition had been allowed to persist for an additional few minutes, damage to the RCP seals could have occurred through a loss of RCP seal cooling water. This in turn, could have resulted in a loss of coolant from the RCP seals in the containment building.

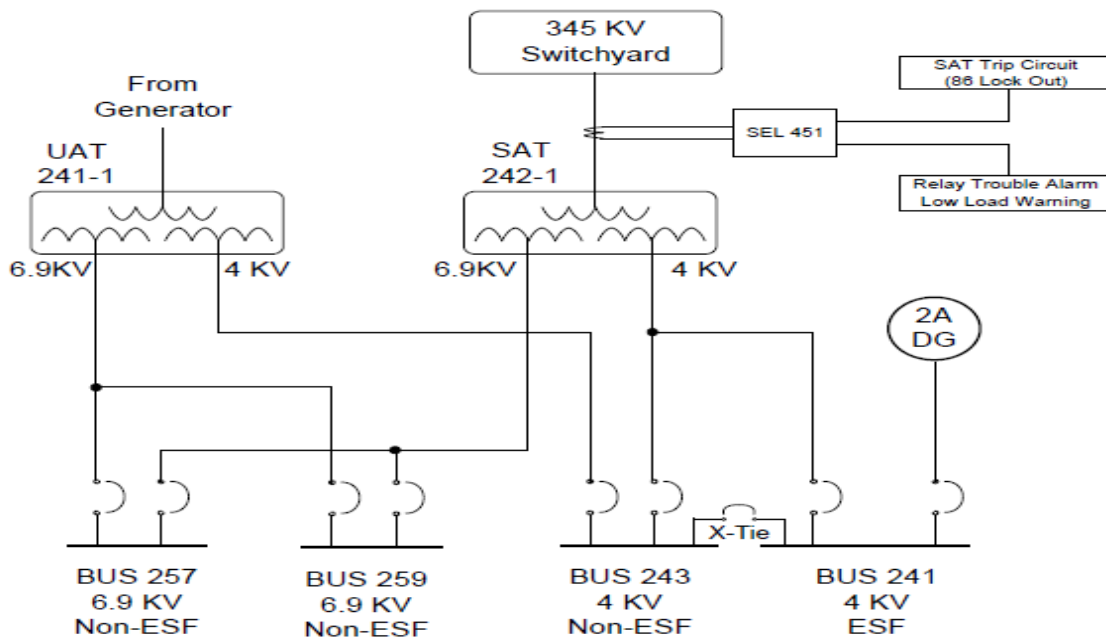

Figure 1. Simplified Schematic of Electrical buses associated with one train (Unit 2)

A second event also occurred at Byron Station Unit 1 on February 28, 2012. This event was also initiated by a failed inverted porcelain insulator that resulted in an open phase as well as a phase-to-ground fault on the line side of the circuit. In this event, the fault current was high enough to actuate protective relaying on the 345-kV system. The 4.16-kV ESFs buses experienced a loss of voltage (LOV) caused by the opening of 345-kV system breakers, which resulted in a separation of the SATs from the 4.16-kV buses. The two EDGs started and energized the 4.16-kV ESF buses, as designed.

Operating Experience

A review of other operating experience identified design vulnerabilities associated with single phase open circuit conditions at South Texas Project (South Texas), Unit 2 (Licensee Event Report (LER) 50 499/2001 001, Agencywide Documents Access and Management System (ADAMS) Accession No. ML011010017); Beaver Valley Power Station, Unit 1 (LER 50 334/2007 002, ADAMS Accession No. ML080280592); and a single event that affected Nine Mile Point, Unit 1 (LER 50 220/2005 04, ADAMS Accession No. ML060620519) and the neighboring James A. Fitzpatrick Power Plant (LER 50 333/2005 06, ADAMS Accession No. ML060610079).

These events involved offsite power circuits that were rendered inoperable because of an open circuit in one phase. In each instance (except South Texas, Unit 2), the condition went undetected for several weeks because offsite power was not aligned to the ESF buses and therefore unloaded during normal operation and the surveillance tests, which recorded phase-to-phase voltage, did not identify the loss of the single phase. At South Texas, Unit 2, offsite power was normally aligned to the ESF and non-safety plant buses, and the operator manually tripped the reactor when the OPC tripped the three circulating water pumps. Operating experience has identified several international events and the International Atomic Energy Agency (IAEA) has published a report titled "Impact of Open Phase Conditions on Electrical Power Systems of Nuclear Power Plants," detailing the significance and consequences of such events (Reference: <https://www.iaea.org/publications/11026/impact-of-open-phase-conditions-on-electrical-power-systems-of-nuclear-power-plants>.)

Industry Initiative to Resolve OPC Design Vulnerability Issue

In response to the Byron event, the industry's chief nuclear officers approved a formal initiative to address OPCs. This initiative was communicated to NRC by the NEI in letter dated October 9, 2013 (ADAMS Accession No. [ML13333A147](#)) and acknowledged in the NRC letter dated December 19, 2013 (ADAMS Accession No. [ML13340329](#)). This letter further indicated that this approved initiative commits each licensee to develop a proactive plan and schedule for addressing the potential design vulnerabilities associated with OPCs. Subsequently, on March 16, 2015, NEI informed the NRC (ADAMS Accession No. [ML15075A454](#)) that, to provide adequate time for OPC implementation, the completion schedule would be revised to December 31, 2018. The industry's chief nuclear officers approved this schedule change in Revision 1 of its document. Subsequently, on September 20, 2018, NEI informed the NRC (ADAMS Accession No. [ML18268A114](#)) that to provide adequate time for implementation of the necessary modifications to the plants and to accommodate an adequate monitoring time afterwards, the completion schedule would be revised to December 31, 2019, with a minimum of 24 months for the completion of the associated monitoring period. The industry's chief nuclear officers approved this schedule change in Revision 2 of its document. In letter dated December 14, 2018, the NRC acknowledged the NEI letter (ADAMS Accession No. [ML18331A156](#)).

On June 6, 2019, NEI submitted Revision 3 to the industry initiative (ADAMS Accession No. ML19163A176), and subsequently submitted the accompanying guidance document, NEI 19-02 "Guidance for Assessing Open Phase Condition Implementation Using Risk Insights," (ADAMS Accession No. ML19172A086) on June 20, 2019. Revision 3 of the industry initiative includes an option for not enabling the Open Phase Isolation System (OPIS) automatic functions based on assessing the change in risk between operating with automatic functions versus reliance on operator manual action to isolate a power supply affected by an OPC. The industry's chief nuclear officers approved the changes in Revision 3 of its NEI document. In a letter dated July 17, 2019, the NRC acknowledged the NEI letter (ADAMS Accession No. ML19193A192). The industry initiative described in the June 6, 2019 NEI letter is the VII referred elsewhere in this TI.

Failure Modes and Consequences of OPC

An OPC may result in challenging plant safety. Operating experience in different countries has shown that the currently installed instrumentation and protective schemes have not been adequate to detect this condition and take appropriate action. An OPC that affects the safety function, if not detected and disconnected promptly, represents a design vulnerability for many nuclear power plants (NPPs). It may lead to a condition where neither the offsite power system nor the onsite power system is able to support the safety functions, and could propagate to station blackout. The January 2012 operating event at Byron Station, Unit 2, revealed a significant design vulnerability where an OPC in the plant's offsite power supply caused a loss of certain safety functions powered by the site's alternating current (ac) electric power system. The loss of these safety functions occurred because the ESF electric power system's protection scheme was unable to detect and isolate the loss of a single phase between the transmission network and the onsite power distribution system. The resulting degraded and unbalanced voltage conditions on redundant ESF buses led to the tripping of equipment required for normal plant operations and safe shutdown. The inability of the protection scheme to detect an OPC and automatically transfer power from the affected electric power system allowed the degraded offsite power system to remain connected to ESF buses, and prevented other onsite ac sources (e.g., Emergency Diesel Generators (EDGs)) from starting and powering these buses. As a result, certain important to safety equipment required for safe operations remained powered by the degraded ac source. The ability of this equipment to perform the required safety functions was questionable as the internal protective features installed to prevent damage from overheating would have either actuated and locked-out the vulnerable components or, depending on the setpoint, allowed continued operation and thereby risk damage from overheating. Furthermore, equipment required for safe shutdown was also at risk of being unavailable for an extended period of time even after the restoration of an operable power source, since operator actions would be required to manually reset tripped protective devices.

In response to the Byron event, the U.S. and international nuclear industry evaluated the consequences of an OPC and an unbalanced voltage condition in a three-phase power system. Continued operation for an extended duration with unbalanced voltage conditions can damage equipment as a result of overheating and vibration, or result in the inadvertent trip of electrical equipment and cause a plant transient. Redundant equipment important to safety which is supplied from a common power source may be damaged when exposed to the unbalanced voltage conditions. The operators may not always be able to respond promptly to prevent multiple equipment damage due to a lack of information available from existing measurements, indications, and automatic actions. The type of fault or transformer winding configuration and grounding techniques can result in low voltage unbalance conditions (e.g., during light load or

no-load conditions), and the degraded conditions can go undetected for a long period of time and may not be revealed until the transformer load is increased.

The effect of OPC on the operating equipment, typically induction motors, depends on a number of factors. An OPC in fully loaded power supply system can result in high current flow in at least one of the three phases of rotating motors. This higher than normal current may actuate the protective scheme, which disconnects the loads from the degraded source. However, the magnitude of the current is dependent on the type of transformer and system configuration to the associated feeder circuits and in some cases the current flow may not actuate protective relaying and result in excessive heating of the motor windings. Unbalanced voltages applied to a three-phase induction motor result in unbalanced currents in the stator windings and introduce a negative sequence voltage. The negative sequence voltage produces a flux rotating in the opposite direction of the rotation of the rotor, producing additional currents and heating. The unbalanced conditions result in overheating of the motor. If the protective scheme actuates and disconnects the load important to safety from the degraded power source, the safe shutdown capability of the plant may be compromised as the affected component may not be available until manual actions are taken to identify the cause of the trip, reset the protective relaying and close the appropriate breaker.

If the circuit with an OPC is in standby mode or lightly loaded, then the low magnitude of current flow in the degraded circuit may not result in sufficient unbalance to actuate any protective device. The OPC may therefore not get detected until a change in plant state or a bus transfer to the offsite standby source results in increasing the load current in the circuit. Once the circuit has increased demand, then the running motors may trip due to overcurrent protection actuation or sustain winding damage due to heating effects.

The operating experience as well as results from analytical studies has confirmed that voltages can be present on all three phases downstream of the OPC due to the interaction of magnetic fields in transformers and three phase loads. In some cases, all three phases on the low voltage winding may have balanced voltages in all phases under no load or lightly loaded conditions. With this regard, the voltage can be regenerated through the systems, but depends upon:

- Transformer winding, core configuration, and rated power
- System grounding arrangements
- Transformer loading, size and type of loads (e.g. motor or static)
- Properties of cables and overhead lines (capacitance, inductance)
- Location of the open phase.

NRC Actions

Based on the Byron Station operating event, the Nuclear Regulatory Commission (NRC) staff issued Information Notice 2012-03, "Design Vulnerability in Electric Power System," dated March 1, 2012 (ADAMS Accession No. [ML120480170](#)). On July 27, 2012, the staff issued Bulletin (BL) 2012-01, "Design Vulnerability in Electric Power System" (ADAMS Accession No. [ML12074A115](#)). Specifically, the NRC asked licensees to provide information by October 25, 2012, on (1) the protection scheme to detect and automatically respond to a single-phase open circuit condition or high impedance ground fault condition on GDC 17 power circuits, and (2) the operating configuration of ESF buses at power.

The Electrical Engineering Branch staff reviewed the information that NRC licensees provided and documented the details of this review in NRC BL 2012-01, in the summary report dated February 26, 2013 (ADAMS Accession No. ML13052A711).

In SECY-16-0068, dated May 31, 2016 (ADAMS Accession No. ML15219A327), the staff requested Commission approval of an Interim Enforcement Policy (IEP), applicable to all operating reactors, to allow the NRC to exercise enforcement discretion for certain instances of noncompliance with the requirements specified in the technical specifications (TS) for electrical power systems (typically TS Section 3.8) and action statement(s) associated with “AC Sources—Operating” and “AC Sources—Shutdown,” and with GDC 17. This IEP could be applicable to certain instances of nonconformance with the principal design criteria specified in the UFSAR.

On March 9, 2017, the Commission issued (ADAMS Accession No. ML17068A297) Staff Requirements Memorandum (SRM) SECY 16-0068, “Interim Enforcement Policy for Open-Phase Conditions in Electric Power Systems for Operating Reactors.” The Commission disapproved the staff’s request to establish an IEP for the purpose of exercising enforcement discretion for purported noncompliance with NRC requirements and nonconformance with design criteria during the pendency of licensee implementation of actions to address an OPC. The SRM stated the following:

“Going forward, the staff should verify that licensees have appropriately implemented the voluntary industry initiative. If the staff determines that a licensee does not adequately address potential OPCs, including updating the licensing basis to reflect the need to protect against OPCs, the staff should consider the appropriate regulatory mechanism to impose the necessary requirements to protect against OPCs using the current guidance on such matters from the Office of the General Counsel.

The staff should provide the Commission with a notation vote paper if this situation arises for any licensee or licensees, with options, including the staff’s recommended path forward. In addition, if disagreements arise between the staff and the industry during implementation of the voluntary industry initiative, and the related issues have policy implications, the staff should promptly raise such issues to the Commission for resolution.

Once satisfactory implementation of the technical resolution has been verified for each licensee, the associated NRC Bulletin should be closed. The staff should update the Reactor Oversight Process to provide periodic oversight of industry’s implementation of the OPC initiative.”

The staff has written this TI for inspectors to verify whether licensees have appropriately implemented the technical resolution of OPC design vulnerability as discussed in their industry initiative document at each operating reactor unit. A TI inspection was chosen as verification of implementation would closely resemble a plant modification inspection.

Four nuclear power plants (River Bend, Palo Verde, Byron, and St. Lucie) were selected as an initial set of plants with four distinct designs (OPC detection and protection schemes) to assess the adequacy of the designs using TI 2515/194, Revision 0. The results of the inspections are documented in inspection reports 05000458/2018010 (ADAMS Accession No. ML18085B197); 05000528/2018010, 05000529/2018010, and 05000530/2018010 (ADAMS Accession No. ML18103A157); 05000454/2018011 and 05000455/2018011 (ADAMS Accession No. ML18138A136); and 05000335/2018002 and 05000389/2018002 (ADAMS Accession No.

ML18208A328). The inspection team consisted of inspectors from each region and a member of the Electrical Engineering Operating Reactors Branch (EEOB) staff from headquarters. The regional inspectors completed Section 03.01 of TI 2515/194, Rev. 0 and the EEOB staff gathered information in accordance with Section 03.02 of TI 2515/194, Rev. 0. The EEOB staff generated an assessment of the inspection results from implementation of the TI dated October 31, 2017 (Rev. 0) to document whether licensees identified OPC vulnerabilities using one of the four OPC designs and implemented the OPIS consistent with the NEI OPC VII. A summary of the staff's preliminary assessments and the areas needing additional clarity were discussed with the industry representatives in two public meetings conducted on September 19, 2018, and October 17, 2018 (ADAMS Accession Nos.: ML18268A342 and ML18309A227, respectively). The NRC staff informed the industry that it would use inspection results, the information discussed in the public meetings, information provided by industry as part of its efforts to address OPC vulnerabilities, the staff's preliminary risk assessment on the impact of OPC (ADAMS Accession No. ML17234A631), and the functional criteria described in the November 25, 2014, NRC letter to NEI (ADAMS Accession No. ML15075A454) to determine whether the licensees are adequately addressing potential OPC vulnerabilities consistent with Commission direction in SRM- SECY 16-0068.

The staff is issuing this revision (Rev. 1) to the TI for NRC inspectors to verify that the plants that choose operator manual action in lieu of automatic protective action are appropriately implementing the VII and adequately addressing the OPC design vulnerability issue. The staff is also deleting Section 03.02, "Information Gathering for VII Assessment (Part 2)," guidance from the TI since the information was obtained during the initial inspections and no longer required to be performed by this TI.

2515/194-03 INSPECTION REQUIREMENTS AND INSPECTION GUIDANCE

General Guidance.

Preparation: Prior to arrival on site, request that key documents be available for on-site inspection (e.g., NEI 19-02 evaluation, calculations, analyses, drawings, procurement specifications, test reports, modification packages including 10 CFR 50.59 evaluations, maintenance, surveillance, test, and alarm response procedures). Arrange with the licensee to have appropriate design, maintenance, probabilistic risk assessment (PRA), and operations staff on-site to support the inspection. Request a brief licensee presentation after entrance meeting describing their electric power system design; normal plant operating alignments; OPC design schemes installed to detect, alarm and actuate (if applicable); bus transfer schemes; maintenance and surveillance requirements; operator walkthrough verifications of the OPC alarm response procedure(s); consequences of extended duration of unbalanced voltage conditions affecting electric equipment if OPC is not automatically isolated; and any licensing basis changes to Updated Final Safety Analysis Report (UFSAR) and Technical Specifications (TS).

Conduct: It is expected that this TI will be performed to verify that licensees have appropriately implemented the VII and adequately addressed potential OPCs. Deviations and exceptions to the VII implementation should be documented in the inspection report with enough details for EEOB staff to review and closeout Bulletin 2012-01. For sites that are implementing the risk-informed evaluation method to demonstrate that operator manual actions will be sufficient to mitigate the impact of an OPC, in lieu of TI Section 03.01.b (automatic protective actions), TI Section 03.01.c will be performed. This inspection activity will be performed after the licensees

have completed their evaluations and analyses, issued plant procedure(s), and completed training for taking manual actions consistent with plant's design and licensing bases. Any identified deviations from the VII and TI guidance will be documented in the inspection report as exceptions. These exceptions will be considered by EEOB staff during the final review and closeout of the Bulletin. Any performance issues identified during the inspection of the VII that are considered to be more than minor in accordance with Inspection Manual Chapter (IMC) 0612 will be reviewed by a panel to determine whether they represent a finding to be documented. These issues may be initially treated as unresolved items (URIs), prior to final disposition.

As directed by the Commission in SRM SECY-16-0068, should disagreements arise between the NRC staff and the industry during implementation of the voluntary initiative, and the related issues have policy implications, the NRC staff will promptly raise such issues to the Commission for resolution.

03.01 Voluntary Industry Initiative.

Determine whether the licensee appropriately implemented the VII dated June 6, 2019 (ADAMS Accession No. ML19163A176), by verifying the following:

a. Detection, Alarms and General Criteria.

1. Either:

OPCs are detected and alarmed in the control room.

OR

(a) The licensee has demonstrated that OPCs do not prevent the functioning of important-to-safety SSCs

AND

(b) OPC detection will occur within a reasonably short period of time (e.g., 24 hours)

AND

(c) The licensee has established appropriate documentation regarding OPC detection and correction.

2. Either:

Detection circuits are sensitive enough to identify an OPC for credited loading conditions (i.e., high and low loading).

OR

If automatic detection may not be possible in very low or no loading conditions when offsite power transformers are in standby mode; automatic detection must happen as soon as loads are transferred to this standby source. Additionally, if automatic detection is not reliable, monitoring requirements should be established on a per shift basis to look for evidence of an OPC.

3. OPC design/protective schemes minimize misoperation or spurious action in the range of voltage unbalance normally expected in the transmission system that could cause separation from an operable off-site power source. Licensees have

demonstrated that the actuation circuit design does not result in lower overall plant operation reliability.

4. New non-Class-1E circuits are not used to replace existing Class-1E circuits.
5. The UFSAR has been updated to discuss the design features and analyses related to the effects of any OPC design vulnerability.
6. Identify whether OPIS detection and alarm components are maintained in accordance with station procedures or maintenance program and that periodic tests, calibrations, setpoint verifications or inspections (as applicable) have been established.

b. Protective Actions.

1. If the licensee determines there is no single credible failure that could cause an OPC, then verify that the licensee has developed and issued a full engineering evaluation to document the basis for OPC as a non-credited event. The Bruce Power and Forsmark operating experience must be considered as part of this analysis.

2. With OPC occurrence and no accident condition signal present, either:

An OPC¹ does not adversely affect the function of important-to-safety SSCs

OR

- (a) TS LCOs are maintained or the TS actions are met without entry into TS LCO 3.0.3 (or equivalent).^{1&2}

AND

- (b) Important-to-safety equipment is not damaged by the OPC^{1&3}.

AND

- (c) Shutdown safety is not compromised^{3&4}

3. With OPC occurrence and an accident condition signal present:

Automatic detection and actuation will transfer loads required to mitigate postulated accidents to an alternate source and ensure that safety functions are preserved, as required by the current licensing bases.

¹ For operating modes where power is supplied from the main generator through unit auxiliary transformers, the evaluation must assume that the main generator is lost and loads must be transferred to the alternate source(s).

² Applies to TS equipment affected by the OPC and not just the TS related to off-site power system. Situations where alternate sources are removed from service if allowed by the TS must be considered.

³ Operator action may be credited in the evaluation if existing regulations and guidelines are met for the use of manual actions in the place of automatic actions.

⁴ Power supplied to spent fuel pool cooling systems must also be considered. The limiting conditions will be those where power is supplied from a single source or an alternate source is used that does not have open phase protection (like a main power transformer back-feed source).

OR

The licensee has shown that all design basis accident acceptance criteria are met with the OPC, given other plant design features. Accident assumptions must include licensing provisions associated with single failures. Typically, licensing bases will not permit consideration of the OPC as the single failure since this failure is in a non-safety system.

4. Periodic tests, calibrations, setpoint verifications or inspections (as applicable) have been established for any new protective features. The surveillance requirements have been added to the plant TSs if necessary, to meet the provisions of 10 CFR 50.36.
5. The UFSAR has been updated to discuss the design features and analyses related to the effects of, and protection for, any OPC design vulnerability.
6. Identify whether OPIS protection components are maintained in accordance with station procedures or maintenance program.

c. Use of Risk-Informed Evaluation Method

For those licensees that opted “to demonstrate that operator manual actions will be sufficient to mitigate the impact of an OPC,” in accordance with VII, Revision 3, Attachment 1 and NEI 19-02, “Guidance for Assessing Open Phase Condition Implementation Using Risk Insights,” instead of automatic protective actions discussed in Section b above, the inspectors should review, verify, and document, as appropriate, the following:

1. Review licensee’s evaluation of NEI 19-02 and Attachment 1 of VII, Revision 3 stated above. Verify that the plant configuration matches the changes made to the PRA model used to evaluate an OPC, and that the logic of the PRA model changes is sound. Consult with regional Senior Reactor Analyst (SRA) if inspectors have any questions or concerns regarding the PRA model.
2. Review the procedure(s) and operator actions required to respond to an OPC alarm and potential equipment trip, with an operator walkthrough and simulator demonstration if possible (during the walkthrough, verify that the procedure which validates that the OPC alarm is legitimate would identify the proper indication to validate the OPCs at all possible locations).
3. Verify that the observations made while carrying out step 2 above match the Human Reliability Analysis (HRA). Consult with regional SRAs as necessary. To achieve this objective:
 - a. Verify that the execution time for each human action as described in the alarm response procedure(s) and the time available to complete each action are reasonable.
 - b. Verify that the environmental and plant operating conditions allow access where needed, procedures have been revised to account for identifying and

isolating an OPC, training has been conducted on these revised procedures, and any equipment needed to complete these actions is available and ready for use.

4. Review the assumptions listed in the NEI 19-02 (Appendix A) evaluation and the sensitivity analyses listed in Section 5 of the evaluation. Verify the assumptions, focusing additional attention on any assumption that causes the sensitivity analysis to exceed the risk threshold defined in the NEI 19-02 evaluation.
5. Review the following to ensure the assumptions, procedures, operator actions, and licensee's analyses specified above are consistent with the plant-specific design and licensing bases and/or the as-built, as-operated plant as appropriate:
 - a. Review the initiating events considered in the analysis.
 - b. Review and verify the boundary conditions specified in VII, Rev.3, Att. 1.
 - c. If certain loads are assumed to be impacted by an OPC (i.e., tripped/locked out or damaged) review the operating procedure(s) for any steps taken to recover the affected equipment (or use of alternate equipment).
 - d. If recovery is assumed as part of the basis in the PRA analysis for impacted electric equipment, verify that the restoration of equipment is based on analyses that demonstrate that automatic trips for isolating any operating equipment during an OPC event did not result in equipment damage. The review of the analyses supporting recovery may include, but not be limited to:
 - 1) System load flow calculations, protective coordination, and failure mode and consequence analyses.
 - 2) Verifying that the licensee appropriately analyzed the capability of safe shutdown equipment to perform the required functions.
 - 3) Review of the licensee's evaluations to verify that ESF/PRA-credited loads (such as large motors, motor-operated valves, inverters, etc.) would not be damaged during the time delay between detection of an OPC by the control room operators and completion of the operator actions.
 - 4) Review of the maximum unbalance seen on ESF buses (considering ESF/PRA-credited loads during normal, anticipated operational occurrences, and design basis accidents) at all voltage levels and verifying how the existing relays are used to protect the equipment from unbalanced power quality issues and potential consequences.
 - 5) Review of the time to recover the tripped equipment and/or replace fuses and damaged equipment given an OPC.

- 6) Review of the time for restoring large motors while factoring the manufacturer recommendations or site/industry guidance for restarting stalled or degraded electric equipment.

2515/194-04 REPORTING AND DOCUMENTATION REQUIREMENTS

Document the completion of this TI in the integrated quarterly report or in a standalone inspection report. Document the VII inspection results and any deviations from the VII in sufficient details to facilitate NRR staff 's final review and closeout of the Bulletin.

2515/194-05 COMPLETION SCHEDULE

This TI is to be completed by July 29, 2022.

2515/194-06 EXPIRATION

The TI will expire on December 30, 2023.

2515/194-07 CONTACT

Any technical questions regarding this TI shall be directed to the Branch Chief of NRR/DEX/EEOB. Any Reactor Oversight Process-related questions shall be addressed to Christopher Cauffman, at (301) 415-8416. Questions can also be sent electronically to Christopher.Cauffman@nrc.gov.

2515/194-08 STATISTICAL DATA REPORTING

Charge all direct inspection and information collection efforts to TI 2515/194 using IPE code TI. Charge all preparation and documentation time to activity code TPD (CAC 000989).

2515/194-09 RESOURCE ESTIMATE

Estimated time to complete TI (Rev.0) is 50-60 hours per site for direct inspection and 24-32 hours for preparation and documentation. In addition, estimated time to complete risk-informed evaluation method of this revised TI is 40-60 hours per site for direct inspection and 24-36 hours for preparation and documentation.

2515/194-10 TRAINING

It is expected that this inspection will be performed by the regional electrical engineering specialist or contractors who are knowledgeable in electrical power system design and analyses for nuclear power reactors. However, a brief training session on the risk-informed evaluation method outlined in NEI-19-02 and VII, Rev.3, Attachment 1, was provided by NRR/DRA/APOB and NRR/DEX/EEOB staff on March 6, 2020.

2515/194-11 REFERENCES

IP 71152, "Problem Identification and Resolution"

IP 71111.17T, "Evaluations of Changes, Tests and Experiments"

IP 71111.18, "Plant Modifications"

IP 71111.21M, "Design Bases Assurance Inspection (Teams)"

END

Attachment 1 – Revision History for TI 2515/194

| Commitment Tracking Number | Accession Number Issue Date Change Notice | Description of Change | Description of Training Required and Completion Date | Comment Resolution and Closed Feedback Form Accession Number (Pre-Decisional, Non-Public Information) |
|----------------------------|---|---|--|---|
| | ML17220A253 DRAFT CN 17-XXX | Draft version of the TI was made public to share with industry during a public meeting held on August 15, 2017. | N/A | ML17158B437 |
| | ML17137A416 10/31/2017 CN 17-024 | <p>Initial issuance. Researched commitments for the last four years and found none. This Temporary Instruction (TI) applies to the holders of operating licenses for operating nuclear power reactors who have implemented actions to protect against open phase conditions (OPCs). This TI is to be performed at all current operating plants with the exception of Seabrook Station, Unit 1, plants seeking NRC approval in accordance with 10 CFR 50.90, and sites that have informed the NRC of their intent to decommission prior to 01/30/2020.</p> <p>CA Note: Initiation of Temporary Instruction 2515/194 To Inspect Implementation of Industry Initiative Associated with Open Phase Condition Design Vulnerabilities in Electric Power Systems ML17240A034</p> | It is expected that this inspection will be performed by the regional electrical engineering specialist or contractors who are knowledgeable in electrical power system design and analyses for nuclear power reactors. However, a specialized brief training on the OPCs will be provided by NRR/DE/EEOB staff prior to 10/31/17. | ML17158B437 |

| Commitment Tracking Number | Accession Number Issue Date Change Notice | Description of Change | Description of Training Required and Completion Date | Comment Resolution and Closed Feedback Form Accession Number (Pre-Decisional, Non-Public Information) |
|----------------------------|---|---|--|---|
| | ML20085H763 | Draft version of the TI was made public to share with industry during a public meeting held on April 6, 2020 | N/A | N/A |
| | ML19339D067 04/15/20 CN 20-021 | Revision 1 - Expanded scope to include all plants. Incorporated guidance for inspecting manual action (i.e. risk-informed) approach consistent with VII, Revision 3. Removed data-gathering instructions (section 03.02) and Table 1 since the HQ staff completed this one-time activity for VII verification effort. | Initial training for this TI was conducted on September and October 2017. It is expected that this inspection activity will be performed by the regional electrical engineering specialist or contractors who are knowledgeable in electrical power system design and analyses for nuclear power reactors with assistance from SRA, if required to perform risk evaluations. However, a brief training session on the risk-informed evaluation method outlined in NEI-19-02 and VII, Rev.3, Attachment 1, was provided by NRR/DRA/APOB and NRR/DEX/EEOB staff on 3/6/20. | ML19339D066 |