

EEG-33  
DOE/AL/10752-33

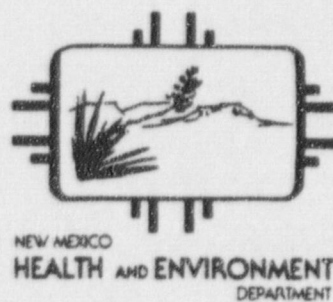

## ADEQUACY OF TRUPACT-I DESIGN FOR TRANSPORTING CONTACT-HANDLED TRANSURANIC WASTES TO WIPP

James K. Channell, John C. Rodgers, and Robert H. Neill

Environmental Evaluation Group  
Environmental Improvement Division  
Health and Environment Department  
State of New Mexico  
P.O. Box 968  
Santa Fe, NM 87503

June 1986

9805040430 980429  
PDR PRM  
71-12 PDR

Environmental Evaluation Group  
Reports

- EEG-1 Goad, Donna. A Compilation of Site Selection Criteria Considerations and Concerns Appearing in the Literature on the Deep Disposal of Radioactive Wastes, June 1979.
- EEG-2 Review Comments on Geological Characterization Report, Waste Isolation Pilot Plant (WIPP) Site, Southeastern New Mexico SAND 78-1596, Volumes I and II, December 1978.
- EEG-3 Neill, Robert H., et al. eds., Radiological Health Review of the Draft Environmental Impact Statement (DOE/EIS-0026-D) Waste Isolation Pilot Plant, U. S. Department of Energy, August 1979.
- EEG-4 Little, Marshall S., Review Comments on the Report of the Steering Committee on Waste Acceptance Criteria for the Waste Isolation Pilot Plant, February 1980.
- EEG-5 Channell, James K., Calculated Radiation Doses From Deposition of Material Released in Hypothetical Transportation Accidents Involving WIPP-Related Radioactive Wastes, November 1980.
- EEG-6 Geotechnical Considerations for Radiological Hazard Assessment of WIPP. A Report of a Meeting Held on January 17-18, 1980, April 1980.
- EEG-7 Chaturvedi, Lokesh, WIPP Site and Vicinity Geological Field Trip. A Report of a Field Trip to the Proposed Waste Isolation Pilot Plant Project in Southeastern New Mexico, June 16 to 18, 1980, November 1980.
- EEG-8 Wofsy, Carla, The Significance of Certain Rustler Aquifer Parameters for Predicting Long-Term Radiation Doses from WIPP, September 1980.
- EEG-9 Spiegler, Peter, An Approach to Calculating Upper Bounds on Maximum Individual Doses From the Use of Contaminated Well Water Following a WIPP Repository Breach, September 1981.
- EEG-10 Radiological Health Review of the Final Environmental Impact Statement (DOE/EIS-0026) Waste Isolation Pilot Plant, U. S. Department of Energy, January 1981.

(continued back page)

## FOREWORD

The purpose of the Environmental Evaluation Group (EEG) is to conduct an independent technical evaluation of the potential radiation exposure to people from the proposed Federal Radioactive Waste Isolation Pilot Plant (WIPP) near Carlsbad, in order to protect the public health and safety and ensure that there is minimal environmental degradation. The EEG is part of the Environmental Improvement Division, a component of the New Mexico Health and Environment Department -- the agency charged with the primary responsibility for protecting the health of the citizens of New Mexico.

The Group is neither a proponent nor an opponent of WIPP.

Analyses are conducted of available data concerning the proposed site, the design of the repository, its planned operation, and its long-term stability. These analyses include assessments of reports issued by the U.S. Department of Energy (DOE) and its contractors, other Federal agencies and organizations, as they relate to the potential health, safety and environmental impacts from WIPP.

The project is funded entirely by the U.S. Department of Energy through Contract DE-AC04-79AL10752 with the New Mexico Health and Environment Department.

Robert H. Neill  
Director

forms which are permitted by WIPP waste certification criteria to contain 1% respirable fines, average 25% combustible material, and can generate potentially flammable or explosive concentrations of hydrogen gas should not be considered either nonrespirable or stable.

A principal advantage of a TRUPACT with double containment is the estimated decrease from 12 to 0.02 in the number of accidents involving radionuclide releases during the WIPP Project. Even minor accidents involving little public radiation exposure are costly to monitor and clean up and can decrease public confidence in the safety of radioactive material shipments. An additional advantage of double containment is the extra protection it is expected to provide in the event of a low probability (0.1-1%)/high consequence accident. These very severe accidents could result in up to 10-30 latent cancer fatalities with the present design. Double containment is estimated to reduce this by at least 60% to 80%.

NRC regulations prohibit all forms of venting and do not permit reliance on filters to meet permissible radionuclide releases. The TRUPACT I design has incorporated continuous venting through filters. The purpose of TRUPACT venting is to reduce the probability of failure from fatigue in the package due to pressure changes caused by altitude and temperature variation. There is also concern whether hydrogen buildup through alpha induced radiolysis of organic material in a sealed TRUPACT would be a problem. EEG is opposed to continuous venting of the TRUPACT on the grounds that it compromises the integrity of the package by providing a pathway for release in case of filter malfunction and the possibility that the vent area is more susceptible to failure during a severe accident and because viable alternatives exist for hydrogen control.

The report evaluates in detail hydrogen generation in TRU wastes because of its relation to the venting issue. While venting of both drums and the TRUPACT might be able to maintain hydrogen concentrations below the minimum flammable concentration of 4% for low-curie loads, it is questionable if control would be adequate for some high-curie loads.

Although DOE has concentrated on venting mechanisms for controlling hydrogen concentrations, promising alternate methods exist and should be investigated. These include the use of hydrogen-getters or hydrogen-oxygen recombiners along with the use of administrative controls. One or more of these alternate methods hold the promise of being more reliable gas control mechanisms than venting and their use would remove the need for venting to control hydrogen concentrations.

DOE has established an upper limit of 12,000 curies of TRU waste in a TRUPACT-I load. This load would contain a more toxic inventory than a spent fuel shipment. Also, because of differences in waste form and package design it is expected that a somewhat higher fraction of the wastes would be released from the TRUPACT than from a spent fuel cask following a severe accident. Since no waste generating site has average waste concentrations as high as 2,000 curies it is not necessary to establish such a high upper limit in order to transport defense wastes to WIPP.

EEG recommends that TRUPACT-I not be certified for transporting any waste to WIPP unless the vents are sealed and the package is limited to 20 curies of plutonium per load. We further recommend that: (1) the TRUPACT be redesigned to include double containment and eliminate continuous venting; (2) the use of methods other than venting for hydrogen gas control be seriously

considered; and (3) the maximum curie content in a TRUPACT be limited to approximately 2,000 curies.

CONTENTS

| <u>Title</u>   | <u>Page</u> |
|--|-------------|
| Foreword.....  | i           |
| EEG Staff.....   | ii          |
| Executive Summary.....   | iii         |
| List of Tables.....  | ix          |
| List of Figures.....   | xi          |
| 1. INTRODUCTION.....   | 1           |
| 2. DOUBLE CONTAINMENT.....   | 7           |
| 2.1 Statement of Issue.....  | 7           |
| 2.2 Regulatory Considerations.....                                       | 7           |
| 2.2.1 Regulations and History.....                                       | 7           |
| 2.2.2 Bases for Exemption Mechanism.....                                 | 13          |
| 2.2.2.1 Applicability of 1974 Regulations....                            | 13          |
| 2.2.2.2 Respirability.....   | 14          |
| 2.2.2.3 Comparison With Spent Fuel<br>Shipments.....                     | 14          |
| 2.2.2.4 Amount of Plutonium Per Shipment....                             | 15          |
| 2.3 Possible Risks and Consequences.....                                 | 15          |
| 2.3.1 Radiological Considerations - Incident<br>Free Transportation..... | 16          |
| 2.3.1.1 External Radiation.....  | 16          |
| 2.3.1.2 Design Effect on Radiation Level....                             | 17          |
| 2.3.1.3 Occupational Radiation Exposure....                              | 19          |
| 2.3.2 Radiological Considerations - Accidents....                        | 20          |
| 2.3.2.1 Fractional Releases From Accidents...                            | 20          |
| 2.3.2.2 Expected Number of Accidents.....                                | 25          |
| 2.3.2.3 Radionuclide Releases From<br>Accidents.....                     | 26          |
| 2.3.2.4 Radiation Doses From Accidental<br>Releases.....                 | 29          |
| 2.3.2.5 Radiological Contamination.....                                  | 30          |
| 2.3.3 Radiological Health Effects From<br>Transportation.....            | 32          |
| 2.3.4 Non-Radiological Risks.....  | 35          |
| 2.3.5 Trading-off Radiological and<br>Non-Radiological Risks.....        | 36          |
| 2.3.5.1 Projected Radiological and<br>Non-Radiological Risks.....        | 37          |
| 2.3.5.2 Is Trading Off Appropriate?.....                                 | 39          |

| <u>Title</u>   | <u>Page</u> |
|--|-------------|
| 3. CONTINUOUS VENTING AND GAS GENERATION.....  | 44          |
| 3.1 Statement of Issue.....  | 44          |
| 3.2 Regulatory Considerations.....   | 45          |
| 3.3 Gas Generation in TRU Wastes.....  | 47          |
| 3.3.1 Gas Generation Processes.....  | 49          |
| 3.3.2 Radiolysis in TRU Waste.....   | 50          |
| 3.3.3 Controlling Pressure and Hydrogen Buildup..  | 61          |
| 3.3.4 Modeling of Hydrogen Gas Buildup.....  | 64          |
| 3.3.5 Alternative Control Strategies.....  | 71          |
| 4. HIGH-CURIE CONTENT .....  | 78          |
| 4.1 Statement of Issue.....  | 78          |
| 4.2 Possible Risks and Consequences.....   | 79          |
| 4.2.1 Comparison With FEIS.....  | 79          |
| 4.2.2 Comparison With Other Radioactive<br>Materials Shipments.....                                  | 80          |
| 4.2.3 Non-Radiological Considerations.....   | 84          |
| 4.3 Operational and Economic Considerations.....   | 84          |
| 4.3.1 Re-Packaging.....  | 84          |
| 4.3.2 Number of Shipments.....   | 86          |
| 5. REDESIGN OF TRUPACT.....  | 87          |
| 5.1 Modifications Being Considered.....  | 87          |
| 5.2 Possible Radiological Impacts.....   | 88          |
| 6. CONCLUSIONS AND RECOMMENDATIONS.....  | 90          |
| 6.1 Conclusions.....   | 90          |
| 6.1.1 Double Containment.....  | 90          |
| 6.1.2 Continuous Venting and Gas Generation.....   | 91          |
| 6.1.3 High-Curie Shipments.....  | 92          |
| 6.2 Recommendations.....   | 93          |
| REFERENCES.....  | 95          |
| APPENDICES.....  | 99          |
| A. Modeling Hydrogen Generation and<br>Dissipation in TRU Waste Packages                             |             |
| B. "Discussion of Propargyl Ethers as<br>Hydrogen Getters with Respect to<br>Nuclear Waste Disposal" |             |

LIST OF TABLES

Page

|     |  |    |
|-----|--|----|
| 1.  | Double Containment (DC) Requirements<br>For Shipments Greater Than 20 Ci Pu.....                         | 8  |
| 2.  | Estimated Occupational Radiation Doses From<br>Loading & Unloading Various TRUPACT Designs.....          | 21 |
| 3.  | Fraction of Radionuclides Released as Respirable<br>Aerosols From Transportation Accidents.....          | 22 |
| 4.  | Expected Number of Accidents Involving Radionuclide<br>Releases During Truck Transportation to WIPP..... | 26 |
| 5.  | Average Amount of Radioactivity<br>Being Transported to WIPP.....  | 27 |
| 6.  | Quantities of Radionuclides Released to the<br>Environment From Truck Accidents.....                     | 28 |
| 7.  | Radiation Population Doses From Expected WIPP<br>Transportation Accident Releases.....                   | 30 |
| 8.  | Estimated Population of Individual Radiation Doses<br>From Severe Transportation Accidents.....          | 31 |
| 9.  | Expected Latent Cancer Fatalities From<br>Transportation to WIPP.....                                    | 34 |
| 10. | Estimated Latent Cancer Fatalities<br>From Severe Transportation Accidents.....                          | 34 |
| 11. | Non-Radiological Fatalities Expected From<br>Shipment of CH-TRU Wastes to WIPP by Truck.....             | 35 |
| 12. | Possible Latent Cancer Fatalities From<br>Leaving Stored Waste at INEL.....                              | 40 |
| 13. | Estimated Deaths Expected to Occur From<br>the WIPP Project.....   | 42 |
| 14. | Venting of TRUPACT.....  | 46 |
| 15. | Major Gas Generation Processes and Rates.....  | 49 |
| 16. | SARP Maximum TRUPACT Loadings.....   | 78 |

LIST OF TABLES

Page

|     |   |    |
|-----|---|----|
| 17. | Comparison of Releases Between FEIS & Chapter 2.....                  | 80 |
| 18. | Comparison of Spent Fuel and<br>TRUPACT Radiological Toxicity.....    | 82 |
| 19. | Releases From Truck Accident Involving<br>Spent Fuel and TRUPACT..... | 83 |

LIST OF FIGURES

Page

|     |   |    |
|-----|---|----|
| 1.  | Points of Origin and Principal Destinations of TRU Waste.....                         | 5  |
| 2.  | TRUPACT-I Transport Package.....  | 6  |
| 3.  | Hydrogen Generation in Experimental Waste Matrices.....                               | 51 |
| 4.  | G (gas) as a Function of Time.....  | 53 |
| 5.  | G (gas) as a Function of Integrated Dose.....   | 55 |
| 6.  | Two Component G (gas) Time-Variant Function.....                                      | 56 |
| 7.  | Model Predicted G (gas) Variation With Integrated Dose.....                           | 58 |
| 8.  | Modeled and Observed Time Varying G (hydrogen) in a Sealed RFP Drum of TRU Waste..... | 59 |
| 9.  | Observed Time-Varying G (hydrogen) in a Sealed RFP Drum of TRU Waste.....             | 60 |
| 10. | Filter Vent Concepts.....   | 63 |
| 11. | Schematic of Drums Inside TRUPACT.....  | 65 |
| 12. | Model Verification Results.....   | 67 |
| 13. | Hydrogen Buildup in Vented Drums.....   | 68 |
| 14. | Vented TRUPACT with 36 Drums (20 Ci/drum).....  | 70 |
| 15. | Rockwell Hanford Operations Catalyst Bed and Vent for Drums of Radioactive Waste..... | 74 |
| 16. | Effects of Getter on Hydrogen Concentration in Drums.....                             | 76 |

## 1. INTRODUCTION

The Waste Isolation Pilot Plant (WIPP) Mission is to provide a research and development facility to demonstrate the safe disposal of radioactive waste resulting from the defense activities and programs of the United States (Ref 1). During the WIPP Project 6,250,000 cu ft of defense transuranic waste (TRU) will be disposed of in a repository 25 miles east of Carlsbad, New Mexico in a bedded salt formation at a depth of 2150 feet. The TRU wastes will be shipped from the Los Alamos National Laboratory (LANL) in Los Alamos, New Mexico, Idaho National Engineering Laboratory (INEL) in Idaho Falls, Idaho, Rocky Flats Plant (RFP), Rocky Flats, CO., Hanford National Laboratory, Hanford, WA., Oak Ridge National Laboratory (ORNL), Oak Ridge, TN., Savannah River Plant (SRP), Aiken, South Carolina, the Mound Laboratories in Miamisburg, Ohio, the Nevada Test Site (NTS) and Lawrence Livermore National Laboratory (LLNL) in California (Ref 2).

The Department of Energy (DOE) has developed a Type B packaging system known as the TRUPACT (Transuranic Waste Package Transporter) to transport the TRU waste to WIPP. The present 36 drum design (TRUPACT-I) will require about 24,000 shipments over a 20 year period beginning October 1988. The relative fraction to be shipped via truck and railroad has not been determined. Figure 1 shows the generation and storage sites of the TRU wastes that will be transported to WIPP via truck or rail. Figure 2 shows a schematic diagram of the TRUPACT.

This report specifically evaluates the 36-drum TRUPACT-I design, although reference is made in places to a possible 48-drum design. Two units are being built to the TRUPACT-I design and it is EEG's understanding that DOE certification will be sought to transport TRU wastes in these units.

While this report was being prepared, the DOE announced plans in May 1986 to try to redesign the TRUPACT to include double containment and eliminate venting. Subsequently, the Albuquerque Operations Office DOE funded the American National Standards Institute to establish a panel to make an independent review of waste packaging issues. The Statement of Work specified, "This task will initially consider the need for separate inner containment for plutonium packagings and the nonradioactive gas venting from packages containing transuranic wastes." The Panel's work will be completed by September 30, 1986. Since DOE appears to be still questioning the technical need for these requirements, EEG believes it is necessary to publish our analyses and conclusion on these health and safety issues related to the transportation of TRU Waste to WIPP.

There are four interrelated sets of safety regulations governing the packaging of radioactive materials transported in the U.S. (Ref 2a). The Department of Transportation (DOT) is responsible for regulating safety in transportation of all hazardous materials, including radioactive materials, and its packaging requirements are given in 49 CFR Part 173. The Nuclear Regulatory Commission (NRC), under the Atomic Energy Act of 1954, as amended, also regulates the transportation of radioactive materials. Through a memorandum of understanding with the DOT, the NRC reviews and approves packages used by its commercial licensees for radioactive materials exceeding Type A quantities and fissile material. NRC's packaging and

transportation regulations are provided in 10 CFR Part 71. The Department of Energy, except for special cases legislated by Congress, is not subject to NRC regulations. DOE packaging requirements, which are applicable to its contractors, closely parallel the provisions of 10 CFR Part 71 and are contained in DOE Orders. The packaging requirements of all three agencies have been brought into conformance, more or less, with the transport recommendations of the International Atomic Energy Agency (IAEA), in which the U.S. is an active participant. The IAEA transportation recommendations are given in IAEA Safety Series #6 (Ref 3).

The issues addressed in this report are whether the existing design of the shipping container (TRUPACT) meets minimal regulatory requirements relating to the safe transport of radioactive materials issued by the U.S. Department of Transportation and the U.S. Nuclear Regulatory Commission and what the health and safety consequences are (if any) of not meeting these regulations.

Transportation regulations that have been issued by the U.S. Department of Transportation (49 CFR 173.7 (d)) permit the U.S. Department of Energy to evaluate, approve and certify its own packages, provided the regulations are equivalent in safety to those specified by the U.S. Nuclear Regulatory Commission in 10 CFR Part 71. This agreement has been in effect since 1973 (Ref 4).

Congressional authorization of the WIPP mission was contained in the December 1979 Appropriations Act for the national security programs and functions of the DOE for FY 1980 (PL 96-164). The express purpose is to provide a research and demonstration facility to demonstrate the safe disposal of radioactive wastes

resulting from the defense activities and programs of the United States exempted from regulation by the Nuclear Regulatory Commission.

Although the DOE was exempted from NRC transportation regulations, ten months later the Department of Energy issued the Final Environmental Impact Statement (FEIS) for WIPP in October 1980 which stated, "The transportation of radioactive wastes to WIPP will comply with the regulations of the U.S. Department of Transportation (DOT) and the corresponding regulations of the U.S. Nuclear Regulatory Commission (NRC)" (Ref 1). Nothing was said regarding the use of DOE transportation regulations in lieu of those issued by NRC or DOT.

While exemptions to regulations are acceptable mechanisms to demonstrate conformance to a standard, the DOE did not indicate in the WIPP FEIS that their commitment to comply with the regulations of the DOT and NRC was through exemptions to be issued by either the DOT or the DOE.

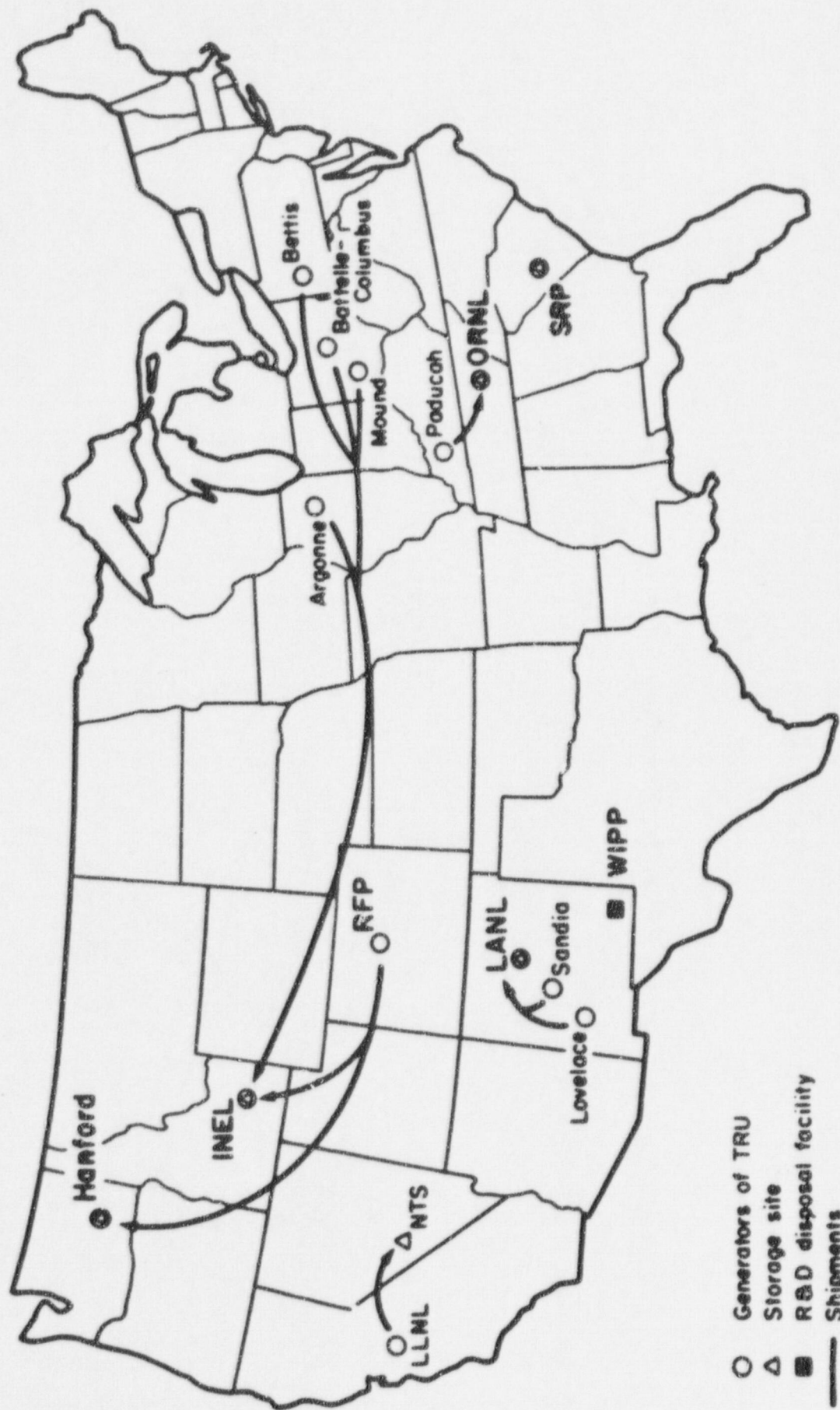

Figure 1. Points of origin and principal destinations of TRU waste.

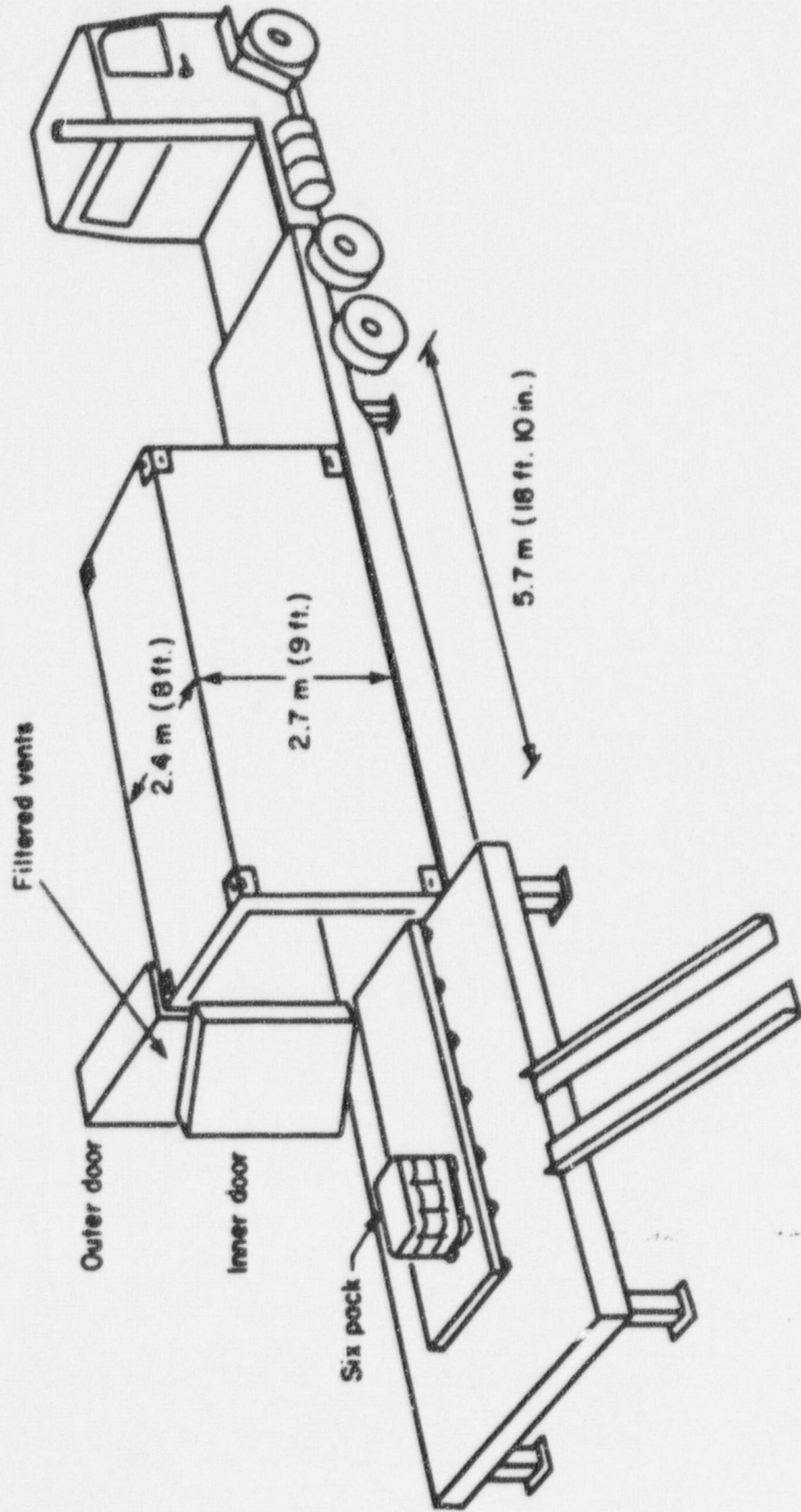

Figure 2. TRUPACT-I transport package.

## 2. DOUBLE CONTAINMENT

### 2.1 Statement of Issue

The TRUPACT was designed in 1978 for single containment (Ref 5). Federal regulations in existence at that time, as well as today, required a double containment design (Ref 6 and 7) for shipments in excess of 20 curies of plutonium. Most of the shipments to WIPP will have more than 20 curies of plutonium.

### 2.2 Regulatory Considerations

#### 2.2.1 Regulations and History

A chronological history of the significant regulatory requirements follows and is also shown on Table 1. In August 1973 the U.S. Atomic Energy Commission (AEC) issued a notice of proposed rule making (NPR) to require special packaging conditions for shipments of plutonium in excess of 20 curies.

In June 1974, the AEC issued regulations (10 CFR 71) (Ref 6) requiring shipments of plutonium in excess of 20 curies to be in a solid form and doubly contained. The AEC noted that after studying the comments on the August 1973 NPR, the effect of their amended provisions "is still to require double containment of the contents." They also stated, "The Commission considers it most important that solid form plutonium be doubly contained and that both barriers in the packaging maintain their integrity under normal and accident test conditions." In 1978 the Transportation Technology Center of the Sandia National Laboratories designed the TRUPACT with single containment.

In December 1979 the DOE commented to the NRC on the double containment requirement of the NRC and specifically requested

TABLE 1

DOUBLE CONTAINMENT (DC) REQUIREMENT FOR SHIPMENTS GREATER THAN 20 Ci Pu

- o Aug 1973 AEC issued NPR to require DC (FR).
- o June 1974 AEC in 10 CFR 71.42 requires DC and solid form effective in 1978 (FR).
- o 1978 Sandia designs TRUPACT with single containment.
- o Dec 1979 DOE and Sandia letters request NRC to exempt shipments of Pu contaminated wastes from DC.
- o Dec 1979 WIPP authorized by Congress.
- o Oct 1980 WIPP FEIS commits to meet NRC trans. regs.
- o May 19 DOE Orders (Regulations) require compliance with NRC 10 CFR 71 DC (DOE 5480.1. Chg 3. p III-6).
- o June 1982 DOE Peer Review in Aug 19 notes that design does not meet 10 CFR 71 NRC DC requirement (SAND -2405).
- o Jan 1983 Sandia response ignores issue of regulatory requirements and exemption for DC (SAND 82-1493).
- o March 1983 DOT requires all Type B packages to be designed and constructed to meet applicable requirements of NRC 10 CFR PART 71 (49 CFR 173. 413).
- o July 1983 DOE issues Draft Order with exemption mechanism from DC (DOE 5480.1A Chg 3 Draft 7-29-83).

- o Aug 1983 NRC confirms requirement for solid form and DC in 10 CFR 71.63 and notes that it turned down request for an exemption to solid form and DC requirements for waste since the general consideration was that the Pu must be in non-respirable form.
- o Aug 1983 EEG identifies non-compliance with DC 10 CFR 71 regulation (EEG-24).
- o Dec 1984 DOE Draft SARP claims justification for single containment.
- o July 1985 EEG states justification for exemption inadequate and recommends DC design.
- o July 1985 DOE establishes exemption mechanism from DC for shipments of plutonium contaminated wastes (Draft DOE Order 5480.3, page 7, 10-10-85).

that shipments of plutonium contaminated solid waste materials be excluded from the double containment requirement. The reason cited (Ref 8) was that the provisions were inconsistent with requirements by the IAEA and the DOT. DOE recommended resolution by conformance with the IAEA provisions.

Sandia National Laboratory also commented to the NRC on the proposed rule in December 1979 and urged the NRC to exempt plutonium contaminated waste materials from the double containment requirement or at least include in the regulations the guidelines upon which the Commission would base its determination for an exemption (Ref 9). The Sandia and DOE requests to exclude waste were subsequently rejected by the NRC in its 1983 revision of 10 CFR 71.

As noted earlier the DOE WIPP FEIS stated that the transportation of wastes to WIPP would comply with DOT and NRC regulations. The TRUPACT design was proceeding without the double containment requirement. Since the Department of Energy has the authority to issue its own regulations on the transportation of radioactive materials that are exempt from NRC licensing, DOE issued orders in May 19 to all its staff and contractors involved with the shipment of radioactive material to meet the NRC regulations for double containment as well as all other requirements contained in NRC's regulations 10 CFR 71.31 - 71.42 "that as presently set forth provide a reasonable set of technical standards" (Ref 10). There were no caveats or exemption mechanisms identified in the DOE Orders. Thus the design was then in apparent violation of the Departments own Orders.

In August 19 a peer review of the TRUPACT preliminary design was convened by Sandia. The peer review committee's report (Ref 11)

published in June 1982, recognized that the design failed to meet NRC regulations and stated as follows: "The TRUPACT designers are faced with a dilemma regarding single or double containment. The regulations specify that packaging for shipments of plutonium in excess of 20 curies, with certain exemptions, must be designed for double containment. The preliminary TRUPACT design (single containment with planned application for exemption from double containment) could fulfill the regulations, provided the exemption is granted. However, if the exemption is not granted, an additional effort later in the program would be required. In assessing the various alternatives for the TRUPACT design, the issue of single versus double containment for CH-TRU should be addressed in the near term to provide the necessary guidance for design purposes."

The failure to meet NRC and DOE design requirements was again recognized in the report's Executive Summary in stating "The overall design approach appears to be satisfactory except for resolution to the regulatory requirements for double containment or exemption therefrom."

The peer review stated, "Double containment for shipments of plutonium in excess of 20 curies per package is required in 10 CFR 71.42, with certain exceptions. The TRUPACT design strategy is to apply for exemption from this double-containment requirement, due to the low risk inherent in CH radioactive waste. It is recommended that the designers secure an early determination of this exemption from the U.S. NRC Transportation Certification Branch or else commence designing for the possibility that double containment will be required." In July 1985 EEG also urged DOE to submit the design to NRC for their evaluation of an exemption (Ref 13).

The subsequent January 1983 Sandia response to the peer review comments (Ref 12) was to ignore the double containment issue and merely state, "TRUPACT is being designed with a single level of containment in the packaging." There was no discussion of the need to obtain an exemption. Distribution of the report was limited to DOE and its contractors, other federal agencies, selected railroads, the American Trucking Association and the American Association of Railroads with the proviso that no one was authorized to further disseminate the information without permission. EEG did not learn of the existence of either the peer review report or the Sandia response reports until 1985 when they were referenced in the DOE draft Safety Analysis for Packaging (SARP). In July 1983 the DOE issued a draft Order that provided the Department an exemption mechanism from the requirements of double containment (Ref 15). The basis for such an exemption was not identified.

On August 5, 1983, the NRC reaffirmed the need for double containment for shipments in excess of 20 curies (10 CFR 71.63, Ref 7) and said that the request was justified when imposed by the AEC in 1974 and the NRC considers that the need for this requirement still exists.

NRC noted in the Supplementary Information to its Federal Register promulgation that it had received a request to exempt plutonium contaminated solid waste from the requirements for solid form and double containment or alternatively to specify the criteria that would qualify for that exemption. The Commission commented that the plutonium must be in non respirable form, exemption must be considered on a case by case basis and that some solid waste forms undoubtedly would not qualify as being sufficiently nonrespirable. The issues are not new. EEG pointed out the failure of the TRUPACT design to conform with the NRC standard in August 1983 (EEG-24, Ref 14).

In December 1984 the DOE claimed that the Draft SARP contained justification for single containment. At a meeting with DOE devoted to TRUPACT in May 1985, EEG stated that the justification was inadequate and on July 29, 1985 suggested several alternatives to DOE that would be acceptable to EEG (Ref 13). They included:

1. Obtain an exemption from NRC:
2. Redesign the TRUPACT for double containment
3. Provide approved type B inner containers in the TRUPACT.
4. Meet the NRC  $A_2$ /week release limits to the inside of the TRUPACT.

In July 1985 DOE promulgated an Order that exempts plutonium bearing wastes from the DOE mandated 10 CFR 71 requirements of double containment, provided that the Office of Operational Safety of the Department approves. No basis is identified for approval despite DOE's urging 2.5 years earlier that NRC list criteria for such an exemption.

#### 2.2.2 Bases for Exemption Mechanism

Regulatory agencies generally provide mechanisms whereby exemptions can be sought from the provisions of regulations issued by those agencies. Since DOE is self-regulating it is the responsibility of DOE's Albuquerque Operations Office (ALO) to demonstrate that an exemption should be provided. The following addresses some of the possible justification for an exemption.

2.2.2.1 Applicability of 1974 AEC Transportation Regulations to Waste Shipments: It is generally agreed that the original

motivation for the 1973 Notice of Proposed Rulemaking of the AEC was concern for reducing hazards from accidental releases of shipments of liquid plutonium nitrate for reactor fuel by requiring solid form and extra packaging for the shipment of plutonium fuel. Therefore, one could argue that since the regulation was never intended to apply to TRU waste and was not addressed in the rulemaking procedure, it is improper to apply such regulations to the shipment of waste to WIPP. However, enclosure A of the AEC's 1974 rulemaking procedure (Ref 16) specifically noted that plutonium contaminated waste would not be included in the list of exempted materials but would be considered for possible exemption on a case by case basis. NRC reaffirmed this position in 1983. Hence, the regulations were intended to apply to waste.

2.2.2.2 Respirability: The double containment requirements were established to take into account that the plutonium may not be in a "nonrespirable" form. However, the DOE WIPP Waste Acceptance Criteria permits up to 1% of the waste (by weight) to be respirable. Thus, shipment of 36 drums of average plutonium concentration (Ref 1) could have 1.5 to 2 Ci of plutonium in respirable form present in the TRUPACT even if the plutonium concentration was not enriched in the respirable particles. Some heat source plutonium shipments would exceed that amount in each drum. Also, the wastes average 25% combustible material and are constantly undergoing radiolytic decomposition (see Chapter 3). EEG does not believe it is prudent to consider such wastes as stable and non respirable.

2.2.2.3 Comparison with Shipments of Spent Fuel: Shipments of spent fuel do not require double containment. If one could show that the inhalation hazard from the release of TRU wastes following accidents were equal to or lower than risks following

the spent fuel following spent fuel accidents, an argument could be made for the adequacy of single containment. This issue is addressed later in the report.

2.2.2.4 Amount of Plutonium per Shipment: One might argue that the amount of plutonium in a shipment of waste is a small quantity in comparison to fuel shipments. AEC defined a large shipment of plutonium as 20 curies or more. The average CH waste shipment identified in Ref 1 is 150 Ci plutonium per shipment. Hence, shipments to WIPP were always considered to be large shipments.

Under the new DOT terminology (Ref 4), "highway route controlled quantities" apply to shipments of more than 6 curies Pu-239, 9 curies Pu-238, and 24 curies Am-241. All shipments to WIPP would be included under this definition.

### 2.3 Possible Risks & Consequences

The purpose of packaging certification is to insure that packages carrying radioactive materials will have sufficient integrity so that the radiological implications of releases from rough handling and severe accidents will be acceptable. Since the quantity and relative toxicity of a container's contents directly effect the consequences of an accident, the requirements of a package increase when more radioactive or more toxic radionuclides are in the container. However, the procedure for determining an acceptable package design, while based partially on test data or analyses, also involves qualitative considerations and engineering judgment.

The double containment requirement was set in a qualitative manner as being practical or reasonable without quantitative

determinations being made of the increments of safety being obtained and the cost of attaining the increments from designs of varying stringency. A qualitative approach also makes the determination of what is "equivalent" to the required design a subjective one. EEG believes that a serious effort should be made to quantify the incremental health and safety benefits that might be obtained from more stringent designs. This quantification may not be conclusive but will be attempted below.

### 2.3.1 Radiological Considerations - Incident Free Transportation

Occupational workers who load, unload, and transport the contact handled transuranic (CH-TRU) waste will receive radiation doses from WIPP related transportation in the TRUPACT. Doses can occur from external radiation during routine handling and transportation and from releases during accidents. Internal doses could occur from resuspension of surface contamination or from releases of radioactive material following failures in the Type A packaging and the Type B TRUPACT. Releases from the TRUPACT would probably occur only following a severe accident. The most probable (and largest) internal radiation doses would occur from inhalation of respirable sized particles, although ingestion of particles through water or food is also possible.

2.3.1.1 External Radiation: There will be radiation doses received by persons along the routes to WIPP from accident-free transportation. These doses are not projected to be large to any individual nor to the total population (Ref 2), but since they have a 100% probability of occurrence they represent virtually all of the expected population dose.

The transuranic elements emit very little gamma radiation and all of the emissions are low energy. The most predominant gamma ray is the 0.06 Mev x-ray from the decay of  $^{241}\text{Am}$ . This "soft" x-ray is relatively easily attenuated, with <1% being transmitted through the walls of TRUPACT. Most of the remaining TRU radionuclides have x-rays of 0.1 Mev or greater that occur with a frequency of  $<10^{-4}$  per disintegration. However, since many shipments will contain very little  $^{241}\text{Am}$  and a 0.1 Mev gamma ray is much less attenuated in the TRUPACT wall it is considered conservative and prudent to assume this higher energy in shielding calculations.

There are minor amounts of fission and activation products present in the TRU waste inventory that emit higher energy gamma radiation. For example, in the wastes stored at INEL there are an estimated 6.2 Ci of  $^{60}\text{Co}$ , 6.1 Ci of  $^{137}\text{Cs}$ , 56 Ci of mixed activation products and 130 Ci of mixed fission products. There are also about 20 Ci of gamma emissions from the decay of  $^{232}\text{U}$  and  $^{233}\text{U}$  in the waste (Ref 18). Although these radionuclides comprise less than 0.1% of the total amount of radioactivity stored at INEL, an evaluation by EEG indicated that about 15% of the radiation escaping the TRUPACT would be due to these higher energy gamma radiations. These higher energy gamma radiations will be ignored in the following analysis because the assumption of 0.1 Mev photons is believed to add adequate conservatism.

2.3.1.2 Design Effect on Radiation Level: The final design of the TRUPACT will have a substantial effect on the amount of radiation that is attenuated within the TRUPACT and its walls. Three factors influence this: (1) the density of material ( $\text{g}/\text{cm}^2$ ) within the packages; (2) the  $\text{g}/\text{cm}^2$  of material in the TRUPACT walls; and (3) the specific materials present in the shielding. A doubly contained TRUPACT would have a greater mass

between the waste and exterior and thus a reduced external dose rate. The possible effect of double containment on the average external radiation level is discussed below.

The DOE has stated informally that double containment might add about 4,000 pounds to the weight of the TRUPACT. A 4,000 pound inner type B steel container would have a weight of about 4.4 gm/cm<sup>2</sup> and would reduce the average exterior radiation level to 60% or less of the level with the present design. Even if double containment limits the number of drums in the TRUPACT to the present 2 wide configuration this would result in a radiation level per drum 10% less than would result from the 3 drum wide configuration that is planned with the 48-drum TRUPACT-II design. (The average INEL drum would have 93+% of the radiation coming from the first row of drums and even a conservative, low-density load would deliver about 93% of the dose from the first row). The difference in dose rate between a 2 drum wide doubly contained TRUPACT and a 3 drum wide singly contained TRUPACT would be greater than 10% if the mass of Kevlar and steel in the walls is reduced in the TRUPACT-II design.

The population radiation dose delivered by TRUPACT transportation (assuming 100% by truck) to WIPP has been estimated to be 3.3 person-rem/y in New Mexico (Ref 2). The collective dose to people in other states was not estimated but from mileage extrapolations would be about 5.4 person-rem. These annual doses are based on a shipment rate of 318,000 ft<sup>3</sup>/y. The total population dose, in-state and out, estimated to be delivered during the repository lifetime (6.2 million cubic feet of waste) would be about 170 person-rem. Thus double containment would result in a dose reduction ranging from 17 to 67 person-rem, depending on whether the TRUPACT dimensions are altered.

2.3.1.3 Occupational Radiation Exposure: Persons involved in the loading, unloading and transporting of wastes in the TRUPACT will receive some external radiation dose from the packages they are handling and internal doses from inhaling air containing resuspended contamination. An evaluation was made of the effects of various TRUPACT designs on the annual occupational radiation dose.

The background document used in this evaluation was "Preliminary Radiation Dose Assessment to WIPP Waste Handling Personnel", WTSD-TME-009, February 1985 (Ref 19). This report included a step-by-step time and motion study of all operations involved in receiving and unloading a loaded TRUPACT, and shipping out the empty TRUPACT. Although the report is considered preliminary and has not been critically reviewed by EEG we believe it is thorough enough to be used as the basis to estimate the effect of different designs on occupational radiation doses.

A number of additional assumptions were necessary in order to compare estimated doses from different designs. A 4,000 pound inner liner was assumed for the double-contained design. It was also assumed that a 48-drum TRUPACT design would have the same wall thickness as the TRUPACT-I design and that weight limits would still permit all 48-drum TRUPACTS to carry a full load. Both of these assumptions are non-conservative, i.e., they would lead to lower estimated occupational doses than the most likely dose. The following detailed assumptions had to be made on each sub task for each design:

1. Whether the time required for the workers to do the sub-task is dependent on the number of TRUPACTS received or the number of six-packs handled;
2. Whether the shielding effect of the TRUPACT walls would be a factor;

3. Whether the exposure from the door was to a 2 x 2 drum stack (36-drum design) or to a 3 x 2 drum stack (48-drum design).

It was decided to assume the time required to unbolt and bolt the inner TRUPACT door was the same per TRUPACT in all designs and that the dose for releasing tie-downs and removing dunnage was per six-pack handled. The average air concentration used in determining internal doses was taken from Table 6.2-4 in the WIPP Safety Analysis Report (Ref 20). The results are shown in Table 2.

The conclusion to be drawn from Table 2 is that a double contained 36-drum TRUPACT will result in a lower occupational radiation dose than either the current design or a 48-drum TRUPACT design. For example, a 48-drum TRUPACT would expect to deliver an additional dose of about about 22 person-rem over the 20-year project lifetime compared to a 36-drum, double contained design.

### 2.3.2 Radiological Considerations - Accidents

2.3.2.1 Fractional Releases From Accidents: Projections have been made in the Preliminary Transportation Analysis (PTA) of the expected frequency and severity of accidents that could cause releases from the TRUPACT and the fraction of radionuclides released for each accident severity category (Ref 2). These release fractions are compared with those estimated in two other documents in Table 3.

Both NUREG-0170 and the RADTRAN II User Guides predict a considerably greater release (factors of 2 to 500) for severity categories VI-VIII than the PTA, but bracket the PTA numbers for

TABLE 2  
 ESTIMATED OCCUPATIONAL RADIATION DOSES  
 FROM LOADING & UNLOADING VARIOUS TRUPACT DESIGNS  
 (Person-Rem/Year)

| Design                      | Radiation Doses |              |                       |
|-----------------------------|-----------------|--------------|-----------------------|
|                             | External        | Internal (a) | Total Incremental (c) |
| TRUPACT-                    |                 |              |                       |
| 36 Drums with D.C.          | 9.8             | 1.3          | 11.1 + 1.2            |
| 36 Drums with D.C. + 10 (b) | 8.6             | 1.3          | 9.9 -                 |
| 48 Drums without D.C.       | 8.9             | 1.4          | 10.3 + 0.4            |
|                             | 10.             | 1.0          | 11.0 + 1.1            |

- (a) 50-year effective dose equivalent.
- (b) assumes 10% more TRUPACT shipments are necessary.
- (c) with respect to double contained design.

TABLE 3

FRACTION OF RADIONUCLIDES RELEASED  
AS RESPIRABLE AEROSOLS FROM TRANSPORTATION ACCIDENTS

| Severity Category | Documents Where Estimated |                           |                        |
|-------------------|---------------------------|---------------------------|------------------------|
|                   | PTA <sup>(a)</sup>        | NUREG-0170 <sup>(b)</sup> | RADTRAN <sup>(c)</sup> |
| I                 | 0                         | 0                         | 0                      |
| II                | 0                         | 0                         | 0                      |
| III               | 5-9 <sup>d</sup>          | 0                         | 2.5-5                  |
| IV                | 5-8                       | 0                         | 2.5-4                  |
| V                 | 5-7                       | 0                         | 2.5-3                  |
| VI                | 5-6                       | 1-4                       | 2.5-3                  |
| VII               | 5-5                       | 5-4                       | 2.5-3                  |
| VIII              | 5-4                       | 1-3                       | 2.5-3                  |

(a) Reference 2.

(b) Reference 21 (Table 5-8 for 1975 plutonium shipments).

(c) Reference 22 (page 71, large loose powder in Type B container).

(d) 5-9 =  $5 \times 10^{-9}$ .

categories III-V. It's not obvious which of these sets of assumptions is more realistic. The NUREG-0170 values are based on tests at Sandia National Laboratory of containers commonly used to ship plutonium in the mid-1970 period. The bases for the release values in the RADTRAN II User Guide were not referenced. An earlier (1983) draft version of the PTA (Ref 23) explained the basis of the PTA release fractions as a footnote to Table D-3: "These data are based on design basis criteria for the TRUPACT and the projections in Reference 1 [NUREG-0170] for typical packages put into service after 1985. The projected performance of the TRUPACT is several orders of magnitude better than indicated in this table". The predicted 1985 releases in NUREG-0170 were: zero for category I-VI;  $10^{-4}$  for Category VII; and  $10^{-3}$  for category VIII.

The test data used in NUREG-0170 probably was not for containers similar to the TRUPACT. The other references provide fewer details. Besides the uncertainty of container design, only a fraction of the WIPP waste form (which is very heterogeneous) fits any of the waste categories assumed in NUREG-0170 or the RADTRAN II User Guide. Since there were release tests conducted with the full-scale testing of TRUPACT Unit-0, it is well to consider how these compare with the above estimates.

TRUPACT Unit-0 was tested after being loaded with 36 drums simulating various waste forms that will be shipped to WIPP. Each type of drum was tagged with a unique tracer so that releases from each waste form could be estimated. The observed release fractions (from the drums to the inside of the TRUPACT cavity) from the full series of hypothetical accident tests averaged  $1.25 \times 10^{-3}$  for total particles and  $2.40 \times 10^{-6}$  for aerosolized and respirable particles. The total fractional release ranged from  $3.3 \times 10^{-6}$  for soft wastes on top drums away from the door to  $6.7 \times 10^{-3}$  for hard wastes on bottom drums near the door (Ref 24).

The 9 meter drop test is considered to be at the lower limit of Severity Category III (Ref 21). However, the total fractional releases mentioned above are the sum from all tests (a 0.3m drop, two 9m drops, four 1m puncture tests, and a thermal test) which is probably equivalent to a single test of higher severity category. Release fractions quoted above are to the inside of the TRUPACT while estimates of accident consequences are based on releases to the environment. No attempt was made to measure the quantity of tracer that was released from the TRUPACT, but since Unit-0 had both door seals and filters fail as a result of the thermal test, it is possible that the loss was about 30% of

the amount that was aerosolized and respirable. This would be a fractional release of about  $7 \times 10^{-7}$ , which is equivalent to a severity category greater than V with the PTA and NUREG-0170, and greater than II with RADTRAN II assumptions. From the above considerations, it is considered reasonable to assume that the present modified TRUPACT design, which passed the 1986 thermal test without loss of door seal or filter integrity, will have the release fractions estimated in the PTA up through a severity category VI accident and will have the release fractions estimated in NUREG-0170 for category VII ( $5 \times 10^{-4}$ ) and the RADTRAN II value for category VIII ( $2.5 \times 10^{-3}$ ). The reason for estimating higher release values for categories VII and VIII is based on the design with vents which could release more radioactivity in a more severe accident. A doubly contained TRUPACT would be assumed to conform to the NUREG-0170 estimate for a 1985 plutonium shipping container (i.e., zero through category VI,  $10^{-4}$  for category VII, and  $10^{-3}$  for category VIII).

Particulates greater than  $10 \mu\text{m}$  also need to be considered because, if released, they would contaminate the environment and require clean-up. It is expected that the mass of particulates associated with particles  $>10 \mu\text{m}$  will be much larger than the mass associated with  $<10 \mu\text{m}$ . For example, the Waste Acceptance Criteria permits 15% of the waste to be particle sizes  $<200 \mu\text{m}$ . Also, in the Unit-0 tests the total release from drums was about 525 times the mass of  $<10 \mu\text{m}$  particles suspended in the TRUPACT cavity. For accidents with Severity Categories I-VI, it is assumed that no particulates  $>10 \mu\text{m}$  will be released from the TRUPACT. This is based on the hypothesis that leakage paths through the filters and seals would be small enough so that larger particles would be discriminated against (as observed with the aerosol sampling train used during the Unit-0 full scale tests). However, in very severe accidents, there could be

a major failure of filters and/or door seals and possibly the release of contaminated particles generated by fire. A sampling indicated that the average ratio of particulate mass  $<210 \mu\text{m}$  to that  $<10 \mu\text{m}$  was 138 (Ref 25). It will be arbitrarily assumed that with the present TRUPACT design the ratio of  $<210 \mu\text{m}$  mass released from the TRUPACT will be 3 times the  $<10 \mu\text{m}$  mass for a Category VII accident and 6 times for a category VIII Accident. For a doubly contained TRUPACT the ratio is assumed to be 3 times the  $<10 \mu\text{m}$  mass for a category VIII accident.

2.3.2.2 Expected Number of Accidents: The PTA uses New Mexico State data on frequency of truck accidents per kilometer on specific routes and national data for rail accidents. The accident frequency rate and the number of kilometers per year traveled in New Mexico is then used in the RADTRAN II Model which incorporates the fraction of accidents in each severity category and the related fractional releases with meteorological and dose conversion data to calculate population doses from accidents. The model does not directly calculate the expected accident frequency in each severity category or the releases (and consequences) resulting from individual accidents. The expected annual and total number of truck accidents for all states in each severity category are shown below in Table 4. Rail accidents will not be tabulated because current expectation is that only a small percentage of shipments will actually be made by rail. Also, calculations indicate that releases per TRUPACT shipment by truck will be slightly greater than releases from rail shipments.

The projections in Table 4 indicate that if the TRUPACT releases some radionuclides for all accidents of severity categories  $> \text{III}$ , there will be more than 12 accidents with the release of radioactive materials during the lifetime of the WIPP Project

TABLE 4

EXPECTED NUMBER OF ACCIDENTS INVOLVING RADIONUCLIDE  
RELEASES DURING TRUCK TRANSPORTATION TO WIPP

| Severity Category | Per Year       | Lifetime Total | Lifetime, Urban <sup>(a)</sup> |
|-------------------|----------------|----------------|--------------------------------|
| III               | 0.49           | 9.6            | 5.5                            |
| IV                | 0.11           | 2.2            | 1.3                            |
| V                 | 0.023          | 0.44           | 0.17                           |
| VI                | 0.010          | 0.19           | 0.043                          |
| VII               | 0.00085        | 0.017          | 0.0032                         |
| VIII              | <u>0.00017</u> | <u>0.0032</u>  | <u>0.00057</u>                 |
| TOTAL             | 0.63           | 12.            | 7.0                            |

(a) Includes both urban and suburban accidents.

and 7 of these would be in urban or suburban areas. If integrity could be maintained for all accidents with severity category  $\leq$  VI there would be only 0.02 accidents involving releases.

2.3.2.3 Radionuclide Releases from Accidents: The number of accidents with releases and the release fraction in each severity category can be combined with an average TRUPACT load to obtain the quantity of radioactivity expected to be released during the WIPP lifetime. The average number of curies per TRUPACT load to be shipped from each generating site and the overall average was derived from data in Reference 26. It was necessary to make several assumptions in deriving these averages since all data were not internally consistent. The results are summarized in Table 5.

TABLE 5  
 AVERAGE AMOUNT OF RADIOACTIVITY  
 BEING TRANSPORTED TO WIPP  
 (Curies of Alpha Radiation)

| Generating Site | Presently Stored Waste   |           | Newly Generated Waste |           | Average Ci per TRUPACT |
|-----------------|--------------------------|-----------|-----------------------|-----------|------------------------|
|                 | Volume (m <sup>3</sup> ) | Curies    | Volume                | Curies    |                        |
| Hanford         | 13,700                   | 44,600    | 24,400                | 42,300    | 17.1                   |
| INEL-HFP        | 35,700                   | 205,000   | 74,300                | 247,000   | 30.8                   |
| LANL            | 6,180                    | 151,000   | 6,070                 | 152,000   |                        |
| ORNL            | 490                      | 21,800    | 545                   | 5,050     |                        |
| SRP             | 3,900                    | 597,000   | 10,600                | 2,030,000 |                        |
| TOTALS          | 60,000                   | 1,020,000 | 116,000               | 2,480,000 | 149. (a)               |

(a) The average mileage weighted load is 184 Ci/TRUPACT - mile.

The quantity of radionuclides associated with respirable sized materials (<10 μm) that might be released from different severity accidents for the average, the average SRP, and the maximum permitted shipments and the expected quantities that would be released during the operating lifetime of WIPP (considering probabilities) are shown in the following Table. As mentioned above, the amount of radionuclides associated with particles >10 μm are be assumed to be 2 times the respirable fraction for a Severity Class VII accident and 5 times for a Severity Class VIII accident.

From Table 6 it is estimated double containment would reduce the expected quantity of radionuclides released from accidents to 28% of that with the current design. Also the doubly contained design would limit the curies released in the class VIII accident to 40% of that with the current design. This would be

TABLE 6

QUANTITIES OF RADIONUCLIDES RELEASED  
TO THE ENVIRONMENT FROM TRUCK ACCIDENTS  
(miccuries, particles  $\leq 10 \mu\text{m MAD}$ )

| Severity Class | Total No. Releases | Present Design Releases |         |                  | Doubly Contained Releases |         |                  |
|----------------|--------------------|-------------------------|---------|------------------|---------------------------|---------|------------------|
|                |                    | Avg/Acc                 | SFP/Acc | Max/Acc Expected | Avg/Acc                   | SFP/Acc | Max/Acc Expected |
| III            | 9.6+0              | 9.3-4 (a)               | 6.8-3   | 5.3-2            | 6.9-3                     | -       | -                |
| IV             | 2.2+0              | 9.3-3                   | 6.8-2   | 5.3-1            | 2.1-2                     | -       | -                |
| V              | 4.4-1              | 9.3-2                   | 6.8-1   | 5.3+0            | 4.1-2                     | -       | -                |
| VI             | 1.9-1              | 9.3-1                   | 6.8+0   | 5.3+1            | 1.9-1                     | -       | -                |
| VII            | 1.7-2              | 9.3+1                   | 6.8+2   | 5.3+3            | 1.5+0                     | 1.4+2   | 1.1+3            |
| VIII           | <u>3.2-3</u>       | 4.6+2                   | 3.4+3   | 2.7+4            | <u>1.5+0</u>              | 1.4+3   | 1.1+4            |
| TOTAL          | 1.2+1              |                         |         | 3.3+0            |                           |         | 9.1-1            |

(a)  $9.3-4 = 9.3 \times 10^{-4}$

a reduction in respirable sized particles from 3.4 Ci to 1.4 Ci for the average SRP waste shipment and from 27 Ci to 11 Ci for the maximum proposed load of 10,700 alpha curies.

2.3.2.4 Radiation Doses From Accidental Releases: Several different types of radiation doses are important and will be estimated. These are:

1. Population doses from the amounts of radiation expected to be released during the operating lifetime of WIPP;
2. Population doses from the more severe accidents that have a low probability of occurrence; and
3. Maximum individual doses (50 year dose commitment and first year dose) from more severe accidents. Also, the possible health effects from these accidents will be estimated.

The estimated average and minimum atmospheric dispersion values (X/Q) in the 22.5 degree downwind sector were taken from Table 33, Appendix H of the WIPP Final Environmental Impact Statement (Ref 1). Key assumptions included population densities of 619 persons/km<sup>2</sup> in suburban and urban areas and 2 persons/km<sup>2</sup> in rural areas, releases occurring over a one hour period, and an individual breathing rate of 1.2 m<sup>3</sup>/hr.

Table 7 indicates that about 23 person-rem are expected from accidental releases from the TRUPACT. This is <14% of the expected external radiation dose to the population along the routes during normal operations and <11% of the expected occupational doses from loading and unloading the TRUPACT. Also, the calculated decrease in expected dose due to double containment is 17 person-rem.

TABLE 7

RADIATION POPULATION DOSES FROM EXPECTED  
WIPP TRANSPORTATION ACCIDENT RELEASES

(50-Year Dose Commitment In Person-Rem)

| Condition                 | ORGAN DOSE               |            |            |
|---------------------------|--------------------------|------------|------------|
|                           | Effective<br>Dose Equiv. | Lung       | Bone       |
| <u>Present Design</u>     |                          |            |            |
| urban/suburban            | 21.                      | 75.        | 220.       |
| rural                     | <u>2.1</u>               | <u>7.5</u> | <u>22.</u> |
| total                     | 23.                      | 83.        | 240.       |
| <u>Double Containment</u> |                          |            |            |
| urban/suburban            | 5.5                      | 20.        | 57.        |
| rural                     | <u>0.6</u>               | <u>2.1</u> | <u>6.3</u> |
| total                     | 6.1                      | 22.        | 63.        |

The numbers in Table 8 show that substantial population and individual dose commitments could result from a Severity Category VII or VIII accident in an urban area. The probability of one of these accidents occurring during the lifetime of the project is about 0.4%, which is low, but certainly not incredible. Furthermore, the maximum individual doses are significant for an average SHP load or for the maximum permitted load. For a 48-drum TRUPACT design, the average doses to populations and individuals would be 33% higher than the numbers in Table 8.

2.3.2.5 Radiological Contamination: A significant radionuclide release from a TRUPACT accident would result in considerable environmental contamination. Contamination beyond a permissible

TABLE 8

ESTIMATED POPULATION & INDIVIDUAL RADIATION DOSES  
FROM SEVERE TRANSPORTATION ACCIDENTS

(50-Year Effective Dose Commitment in Person-Rem and Rem) (e)

TRUPACT LOADING CONDITION

| Dose Recipient            | Average   |          | Average SRP |       | Maximum |       |
|---------------------------|-----------|----------|-------------|-------|---------|-------|
|                           | VII (a)   | VIII (a) | VII         | VIII  | VII     | VIII  |
| <u>Present Design</u>     |           |          |             |       |         |       |
| Population (c)            | 3.1+3     | 1.6+4    | 2.3+4       | 1.1+5 | 1.8+5   | 8.9+5 |
| Max Individ               | 2.7+0     | 1.3+1    | 1.9+1       | 9.7+1 | 1.5+2   | 7.6+2 |
| <u>Double Containment</u> |           |          |             |       |         |       |
| Population                | 6.1+2     | 6.1+3    | 4.5+3       | 4.5+4 | 3.6+4   | 3.6+5 |
| Max. Individ              | 5.3-1     | 5.3+0    | 3.9+0       | 3.9+1 | 3.0+1   | 3.1+2 |
| <u>Probability (b)</u>    |           |          |             |       |         |       |
| Annual                    | 1.7-4 (d) | 2.9-5    | 1.9-5       | 3.4-6 |         |       |
| Total                     | 3.2-3     | 5.7-4    | 3.7-4       | 6.6-5 |         |       |

- (a) Severity category VII and VIII accidents
- (b) Probabilities are for occurrences in urban & suburban areas
- (c) 5% of the time maximum doses would be double the values
- (d)  $1.07-4 = 1.7 \times 10^{-4}$
- (e) The fraction of the 50-year effective dose commitment delivered in the first year is 0.10.

level would have to be decontaminated or the area would have to be quarantined for certain uses. The required remedial action could be very expensive especially if the action occurs in an urban or suburban area. Also, all radionuclide releases, not just those that are associated with respirable sized particles, will contribute to the level of contamination.

No attempt will be made here to specifically estimate the cost of cleanup that might be typical along WIPP routes. However, from the curve in Figure 3-2 of the Urban Study (Ref 27) and adjusting for New Mexico urban/suburban density (about .043 of Manhattan's density) and for 1986 prices (about 1.5 times 1979 prices) it is estimated the cost would be about \$16 million for a category VIII accident for an average SRP load without double containment and \$5 million with double containment. So double containment would result in significant economic savings from a very severe accident.

An additional advantage of double containment would be the drastic reduction (from 12.5 to 0.02) in the expected number of release accidents during the WIPP campaign (see Table 4). While most of these additional accidents would be small and not involve significant cleanup costs they would require monitoring costs and a great deal of public explanation.

### 2.3.3 Radiological Health Effects from Transportation

The relationship between the amount of radiation received and the expected health effects has been studied extensively by national and international organizations as well as by individuals. Correlations between dose and effect involve a number of variables including type of radiation, organ being irradiated, age at time dose is delivered, sex of the person

receiving the dose, and in some cases the rate at which the dose is delivered. The conversion factors determined by different investigators vary considerably and in many cases a range is reported rather than a single number. This report will use a range of 100-250 latent cancer fatalities (LCF) per million person-rem of 50-year effective dose equivalent and external whole body radiation. This range encompasses the values used in the 1980 BEIR report (Ref 17) and the suggested values in the RADTRAN II code. Other health effects, such as genetic and life-span shortening will not be estimated here.

Tables 9 and 10 indicate that a double contained TRUPACT is expected to result in fewer latent cancer fatalities than either the present design or a 48-drum design both from routine transportation and from releases following severe accidents. However, the expected LCF are low in all cases and the differences between designs are not enough to justify one design over others.

The justification for double containment rather than single containment is based on the increased safety in case of accidents. The drastic reduction in the expected number of accidents with radionuclide releases will significantly reduce costs of monitoring, quarantine and decontamination and have a positive benefit on public perception of transportation safety. As shown in Table 10, the decrease in estimated latent cancer fatalities due to double containment is substantial for Class VII and VIII accidents. We believe the additional protection against low (0.1-1.0%) probability of accidents that can be obtained by double containment already warrants its incorporation into the design of the TRUPACT.

TABLE 9  
 EXPECTED LATENT CANCER FATALITIES  
 FROM TRANSPORTATION TO WIPP

| TRUPACT MODEL    | Incident Free Transportation Population | Occupational | Expected Accidents | Total LCF |
|------------------|---|--------------|--------------------|-----------|
| Present Design   | .017-.042                               | .022-.054    | .002-.006          | .041-.10  |
| Double Contain   | .010-.025                               | .019-.048    | .001-.002          | .030-.075 |
| D. Contain + 10% | .010-.025                               | .020-.050    | .001-.002          | .031-.077 |
| 48 Drum          | .011-.028                               | .022-.054    | .002-.006          | .035-.088 |

TABLE 10  
 ESTIMATED LATENT CANCER FATALITIES  
 FROM SEVERE TRANSPORTATION ACCIDENTS

| TRUPACT Model    | Average Load |            | Average SRP Load |            |
|------------------|--------------|------------|------------------|------------|
|                  | Class VII    | Class VIII | Class VII        | Class VIII |
| Present Design   | 0.31-0.77    | 1.5-3.8    | 2.3-5.6          | 11.-28.    |
| Double Contained | 0.06-0.15    | 0.61-1.5   | 0.45-1.1         | 4.5-11.    |
| 48 Drum          | 0.41-1.0     | 2.0-5.0    | 3.0-7.5          | 15.-33.    |

2.3.4. Non-Radiological Risks

The transportation of material by truck or train also involves risks unrelated to the nature of the cargo. The principal risks come from vehicle accidents that cause injuries and deaths. There also are latent cancer fatality deaths that would be expected from motor vehicle emissions. Non-radiological unit risk factors presented in SAND 83-0867 (Ref 28) are used in Table 11 to estimate non-radiological risks from shipment of CH-TRU to WIPP by truck.

Table 11 lists expected non-radiological fatalities from truck shipments that are about two orders-of-magnitude greater than the expected Latent Cancer Fatalities from radiation exposure. This could lead one to contend that non-radiological safety is a more important concern in package and system development than is radiological safety.

TABLE 11

NON-RADIOLOGICAL FATALITIES EXPECTED FROM  
SHIPMENT OF CH-TRU WASTES TO WIPP BY TRUCK

| Area     | Total Round Trip<br>distance ( $10^6$ km) | Fatalities  | Injuries   | Latent<br>Cancer<br>Fatalities |
|----------|---|-------------|------------|--------------------------------|
| Rural    | 68.                                       | 4.6         | 56.        | -                              |
| Suburban | 3.8                                       | .06         | 1.4        | -                              |
| Urban    | <u>0.8</u>                                | <u>.008</u> | <u>0.4</u> | <u>.08</u>                     |
| Totals   | 73.                                       | 4.7         | 58.        | .08                            |

It should be noted that the high non-radiological to radiological fatality ratios estimated for 100% truck shipments

to WIPP are not estimated for rail shipments. There are several reasons for this difference:

1. Fatal accident rates per kilometer for trucks average about 3-1/2 times those for a railcar;
2. A railcar will hold 2 TRUPACTS, therefore only half as many shipments are required;
3. Rail shipments move at a much slower average speed, partially because an average train shipment is stopped most of the time. This increases the routine radiation dose to the public along the route. Using the assumptions in Reference 28 for all wastes that could be physically shipped to WIPP by rail leads to the prediction that there would be about 1.0 accidental deaths, 0.1 non-radiological latent cancer fatalities, and 0.8 latent cancer fatalities from incident free radiation exposure.

#### 2.3.5. Trading Off Radiological and Non-Radiological Risks

In prepared testimony to the NM Radioactive Materials Legislative Committee on September 25, 1985, the Director of the Joint Integration Office (JIO) Albuquerque Operations Office, DOE, stated that an appropriate justification for using a TRUPACT design that contains only single containment is that the number of lives that could be saved from non-radiological risks would greatly exceed the expected increase in radiological deaths. Two aspects of this argument need to be evaluated:

1. Is the contention factually correct?

2. Is it appropriate to trade-off radiological and non-radiological health and safety risks?

These two issues are discussed separately below.

2.3.5.1 Projected radiological and non-radiological risks: The analysis above indicates that for 100% truck shipments the expected non-radiological deaths are about two orders of magnitude greater than the expected radiological deaths. Therefore, for this condition it seems reasonable to expect that the possibilities of reducing total deaths by changes in the transportation system would be most likely in the non-radiological area. JIO has contended that non-radiological deaths are directly related to vehicle miles and that since double containment would reduce the payload, require more shipments, and increase vehicle miles, it would result in more total deaths.

Many steps can be taken to reduce death per vehicle mile (e.g., better driver training, more rigid safety checks of vehicles, routing and timing of transportation). However, these steps could (and should) be applied rigidly to whatever transportation system is chosen. Consequently, we agree that total vehicle-miles is still the most appropriate index to estimate non-radiological deaths.

For transportation by rail the radiological and non-radiological risks are similar (the above estimate gives a non-radiological to radiological risk of about 1.4, which is probably within the error of the estimate) and the minimization of total risk would require consideration of both types of risk. Also, truck shipments are expected to result in 2.7 times the total deaths as rail shipments. This suggests that the most efficient action

that might be taken to save lives would be to ship all wastes by rail, if rail access is available. Present information from J10 is that most shipments are expected to be by truck.

Double containment would result in extra vehicle miles if the change in design reduced the number of drums or boxes that could be carried or if the extra weight of the TRUPACT required a decrease in the number of containers per shipment. The J10 indicates that double containment would result in a 30% increase in vehicle-miles. No analysis has been presented to justify this figure, though it is believed to be simply the ratio of the net payload in the present TRUPACT (18,200 pounds) to that which might exist with double containment. There are two reasons why this figure is probably too high:

1. From limited available data (1978 data from INEL only - Ref 29) it appears that most shipments will not be weight limited. The average weight of drums would amount to only 11,900 pounds per TRUPACT and a load of 2 Rocky Flats boxes would average only 5,600 pounds. If a large number of drums were processed At Idaho National Laboratory (INEL) in the Process Experimental Pilot Plant (PREPP) loads could become weight limited since these drums weigh about 1,200 pounds each. Extensive processing would also drastically effect the efficiency DOE believes could be attained with a 48-drum TRUPACT design.
2. Preliminary data suggest that, with proper load management, a large number of TRUPACT loads would not exceed 20 curies of plutonium and could be shipped with single containment (Ref 29).

If all shipments to WIPP are by truck in a doubly contained TRUPACT, we estimate an increase in the expected non-radiological deaths by 5-10% and this increase would be greater than any expected decrease in radiological deaths. The estimated non-radiological deaths would increase by 0.48 from 10% greater-mileage and radiological deaths would decrease by 0.02. However, if the intent is to minimize total expected non-radiological deaths, the WIPP Project Office (WPO) should ship all wastes by rail from those storage or generation sites that have rail access. Maximizing rail shipments would save an expected 2.9 lives.

2.3.5.2. Is trading off appropriate? The concept of balancing activities involving radiation risks so that the total expected health and safety effects from both radiological and non-radiological risks is minimized. However, we do not believe this "trade-off" approach has ever been used in setting standards, writing regulations, or in making radiation protection and waste management decisions. Furthermore, it appears that even in transportation of CH-TRU wastes to WIPP this philosophy is not being applied consistently. If it were, all possible shipments would be by rail. The principal philosophy behind radiation protection regulations and decision-making appears to be twofold:

1. To be certain that expected radiation doses to individuals and populations meet standards that have been developed;
2. To offer additional protection against the higher consequence - lower probability accident. These high consequence effects are hidden when they are combined with probability and presented only as expected doses.

DOE did not use the least expected fatality concept for decision-making in either the WIPP Final Environmental Impact Statement or in the various draft Environmental Assessments for the first repository candidate sites (Ref 30).

Appendix N of the WIPP FEIS concludes that leaving presently stored wastes at INEL would result in no expected health effects, would cost only \$600,000 per year, and would have a danger of latent cancer fatalities from three low-probability scenarios. These are shown in Table 12.

Table 12  
 POSSIBLE LATENT CANCER FATALITIES FROM  
 LEAVING STORED WASTE AT INEL

| Scenario           | LCF        | Comments   |
|--------------------|------------|--|
| Explosive Volcano  | 0.48 - 4.4 |  |
| Volcanic Lava Flow | 2.4 - 22.  | Dose commitment calculations for this scenario subject to large uncertainties. |
| Human Intrusion    | 0.04-0.38  |  |

Greater confinement disposal at INEL was estimated in Appendix N to reduce these possible LCFs by a factor of one hundred for a capital cost of 1.9 to 21 million dollars and a \$600,000/year surveillance cost.

The FEIS did not compare these low probability LCFs with the expected and low probability deaths that might result from constructing and operating the WIPP site. The low probability LCFs in Table 12 can be compared with those from Class VII or VIII accidents in Table 10 and one can speculate on the relative probabilities of the various scenarios. There clearly will be expected deaths from WIPP construction, transportation and operation. These are estimated in Table 13.

Table 13 indicates that the expected fatalities that will occur from shipping INEL and RFP wastes to WIPP will be 4.7 if all shipments are by truck and 3.0 if rail shipments are optimized.

Thus, the decision to dispose of INEL & RFP TRU wastes at WIPP traded off 3.0 expected deaths from non-radiological causes in order to prevent several low probability events from occurring. This trade-off also involved the expenditure of over \$0.5 billion more than would have been necessary to monitor the wastes at INEL and introduced the possibility of low probability transportation accidents. The DOE's current plans to ship all wastes by truck, would result in an additional 1.8 expected deaths.

We conclude that the original decision to build the WIPP Project was made because of the desire to protect against low probability radiological doses and environmental contamination and did not consider minimizing either non-radiological deaths or costs. Furthermore, the DOE claim that double containment is undesirable because of the extra highway deaths that would occur is inconsistent with plans to ship 100% by truck and thereby increase the expected deaths by about 6 times that due to double containment.

TABLE 13

ESTIMATED DEATHS EXPECTED TO  
OCCUR FROM THE WIPP PROJECT

| Source of Death               | Expected Deaths     |            | Comments                                  |
|-------------------------------|---------------------|------------|---|
|                               | Total               | INEL&RFP   |   |
| <u>At Site</u> <sup>(a)</sup> |                     |            |   |
| Radiation                     | 0.03                | .01        | non-TRIUMPH related occupational exposure |
| Construction                  | 0.20 <sup>(b)</sup> |            | assume $4 \times 10^6$ person-hours       |
| Surface Op.                   | 0.48                |            | assume $1 \times 10^6$ person-hours       |
| Underground Op.               | 2.00                |            | assume $2 \times 10^6$ person-hours       |
| Other Employees               | <u>0.24</u>         | _____      | assume $10 \times 10^6$ person-hours      |
| Total Site                    | 3.0                 | 1.8        |   |
| <u>Transportation</u>         |                     |            |   |
| All truck                     |                     |            |   |
| rad                           | .08                 | .04        |   |
| non-rad                       |                     |            |   |
| total                         | <u>4.8</u>          | <u>2.9</u> |   |
| Total                         | 4.9                 | 2.9        |   |
| Max Rail                      |                     |            |   |
| rad                           | .80                 | .50        |   |
| non-rad                       | <u>1.0</u>          | <u>.68</u> |   |
| Total                         | 1.8                 | 1.2        |   |

(a) Estimates of deaths per person-hour taken from pages 4-45 and 5-29, Reference 30.

(b) One fatality has already occurred.

The DOE Office of Civilian Radioactive Waste Management (OCRWM) estimated the costs and the radiological and non-radiological risks of transporting high-level wastes to the various proposed repository sites. These differences are substantial. e.g., shipment to Richton Dome by rail was \$0.98 billion and 12.3 deaths less than shipment to Hanford. Truck shipments are estimated to cause about 3.3 times the total deaths as rail shipments. Yet under the grouping of environment, socioeconomics, and transportation Hanford was ranked first and Richton fourth. It appears that OCRWM does not consider either cost or expected deaths from transportation to be a very important criteria in repository siting. However, OCRWM's present preference is toward rail shipment even though costs are similar to truck (from +14% at Richton to -14% at Hanford). So, unlike the WIPP Project, OCRWM is favoring the transportation mode that results in the least deaths.

EEG concludes that using the trade-off of expected non-radiological deaths with expected radiological deaths has little or no precedent in waste management decisions and has not been applied elsewhere in the WIPP project, even in the transportation area. We believe invoking this principle to argue for an exemption to double containment is inconsistent with prior decisions, unprecedented and inappropriate.

### 3. CONTINUOUS VENTING AND GAS GENERATION

#### 3.1 Statement of Issue

The incorporation of venting in the TRUPACT raises the following concerns: Type B packages must be designed to pass rigorous tests for leak-tightness so that even in severe accident conditions only extremely small quantities of particulate radionuclides could escape. At the same time, it reduces the probability of failure due to changes in internal pressures from causes such as changes in elevation during transport or gas generation in the waste. These latter two conditions suggest potential advantages to continuously venting the TRUPACT in order to control pressure buildup. A third concern is that the gases being generated in the waste include hydrogen and oxygen, which can form a potentially flammable or explosive mixture at concentrations above 4 or 5 volume percent. Department of Transportation regulations prohibit shipment of wastes in packages subject to formation of explosive mixtures of gases. Venting might be considered a preventive measure if it could be shown to be effective for controlling flammable mixtures of hydrogen and oxygen in both the TRUPACT and the Type A packages. However, in the regulatory experience to date, there is no evidence that filtered venting to prevent the buildup of explosive mixtures of hydrogen has ever been an NRC accepted design alternative to purging of containers followed by controlled shipment-time, or to using catalytic recombiners to limit radiolytic hydrogen buildup when large quantities of hydrogen might be generated.

DOE has contended gas generation is of little concern in causing an increase in pressure that could result in package failure. But extremes in altitude variation and environmental

temperatures could cause a 7.5 psig pressure differential in a sealed TRUPACT. If there were frequent cyclical pressure changes of this magnitude DOE has stated that this might shorten the operational life of the TRUPACT packaging as a result of inner frame weld joint fatigue (Ref 31). A detailed engineering analysis of pressure-induced weld joint failure has yet to be published by DOE, so the full details of the contributing design factors or the probability of such a failure mode cannot be commented on here.

The issues for the TRUPACT are whether venting is both needed and permissible to preclude fatigue failure and formation of flammable or explosive mixtures of hydrogen gas in the shipping container, or whether these conditions can be avoided by other means.

### 3.2 Regulatory Considerations

A chronological history of the more significant regulatory requirements is shown on Table 14.

In relationship to the TRUPACT design, several events are especially significant. In 1979, the IAEA issued non-obligatory regulations that permitted both continuous and intermittent venting. In 1981 Sandia designed the TRUPACT for continuous venting, although DOE Orders (Ref 10) had prohibited such a feature in May 1981. Although NRC issued regulations in August 1983 intended to conform to the draft IAEA regulations, continuous venting during transport was specifically banned [10 CFR 71.43 (h)]. The demonstration of compliance with the permitted release limits cannot depend on filter performance [10 CFR 71.451(b)].

Table 14

VENTING OF TRIPACT

|   |           |  |
|---|-----------|--|
| o | 1973      | IAEA does not permit continuous venting for Type B packages. IAEA Safety Series No. 6, 1973 Edition.   |
| o | Jan 1978  | NRC prohibits direct venting to atmosphere [10 CFR 71.35 (c)].   |
| o | 1978      | Sandia begins TRIPACT design.  |
| o | 1979      | IAEA prohibits continuous venting for type B packages. IAEA Safety Series No. 6, Revised Edition 1979.   |
| o | May 1981  | DOE prohibits direct venting to atmosphere. DOE 5480.1, chg 3, III-12.   |
| o | 1981      | Sandia designs TRIPACT for continuous venting.   |
| o | Aug 1981  | Sandia Peer Review does not discuss issue (SAND -2405) Published June 1982.  |
| o | Dec 1982  | DOE convenes major meeting to address hydrogen gas generation problem in transportation.   |
| o | Aug 1983  | NRC prohibits continuous venting 10 CFR 71.43 (h). Compliance with permitted release limits cannot depend on filters, 10 CFR 71.51 (b).        |
| o | Aug 1983  | EEG issues report based on sealed TRIPACT (EEG-24).  |
| o | Dec 1984  | DOE Draft SARP claims justification for continuous venting.  |
| o | 1985      | IAEA regulations permit intermittent venting but prohibit the use of filtration to comply with release limits. IAEA Safety Series No. 6, 1985. |
| o | July 1985 | EEJ states justification for exemption inadequate and recommends DOE apply to NRC for exemption.   |

Noting that continuous venting was banned by NRC, EEG issued a report in August 1983 (Ref 14) with gas generation calculations predicated on the TRUPACT being sealed. EEG has repeatedly pointed out at meetings with DOE that the design with continuous venting violates DOT regulations as well as those issued by NRC and DOE (Ref 13).

After extensive draft revisions the IAEA published regulations in 1985 (Ref 3) permitting intermittent venting of type B(M) packages during transport, provided that the operational controls for venting are acceptable to the relevant competent authorities. Since NRC does not permit intermittent venting, it would not apply to the U.S. However, NRC has committed, in the supplementary information accompanying its final 1983 rule, to conform with the anticipated IAEA revisions (1985). Nevertheless, the 1985 IAEA revisions continue to impose a ban on filtration for B(U) packages. The 1985 IAEA regulations do not contain any overt statement on continuous venting but appear to preclude such a feature by not permitting a pressure relief system from the containment system. Hence the design appears not to conform with the IAEA regulations.

### 3.3 Gas Generation in TRU Wastes

The generation of gases from the degradation of defense Transuranic waste forms has been under investigation for the past decade. A number of reviews and summaries of data generated by these investigations have been prepared during this time (e.g., Molecke and Clements, references 32 and 33) to assist in the development of Waste Acceptance Criteria for WIPP and the designs of the TRUPACT. Most of the early work focused on overpressurization effects of (largely inert) gas generated after wastes are emplaced in the repository.

During this study process, the specific concerns about gas generation have changed, to the present emphasis on hydrogen gas buildup in shipping containers. The 1981 decision to vent the TRUPACT has been reconsidered several times in the recent past. In May 1986 the Albuquerque Operations Office announced that they were recommending that a redesigned TRUPACT (TRUPACT-II) be vented during shipment.

The aim of the discussion in this chapter is to examine the suitability of the present plans for the design of Type A containers and the TRUPACT transportation package to deal with gas generation related problems.

The chief concerns related to gas generation are: 1) the production of flammable or explosive concentrations of gases in Type A packages, the TRUPACT, or in the repository itself; 2) the release of particulate contamination with carrier gases in Type A or TRUPACT packages; and 3) the long-term pressurization of the repository (post-closure). Only the first two are relevant to the present discussion. The first issue can be translated into more specific package design issues based on the strategy adopted to prevent the formation of flammable or explosive mixtures. Until recently, DOE strategy favored the use of venting both Type A and TRUPACT packages to achieve control. There is evidence that venting (RFP bung filter vent, or Hanford vent clip) will control hydrogen concentrations to below flammable levels in drums or boxes containing modest alpha curie loadings and low average G-values when in storage. There are no data for such drums in either a sealed or vented TRUPACT. However, it is questionable whether venting of the TRUPACT can be depended upon to maintain hydrogen concentrations below flammable levels when carrying a high curie load. It is also not clear whether either Type A or B packages can be certified with continuous venting. These considerations are pursued below.

### 3.3.1 Gas Generation Processes

There are a number of gas generation processes in TRU wastes: bacterial, thermal, radiolysis, and corrosion. Current data (Table 15) indicate that bacterial degradation of wastes has the potential for the greatest gas generation rate (moles/yr/drum) provided the right conditions exist (temperature, substrate, presence or absence of oxygen, etc.). However, bacterial action does not appear to be significant for the short-term, transportation phase of TRU waste handling.

Table 15  
MAJOR GAS GENERATION PROCESSES AND RATES

| Process                 | Material                          | Mole/yr-drum |
|-------------------------|-----------------------------------|--------------|
| Bacterial Decomposition | Composite, aerobic                | 0.9-12       |
|                         | Composite, anaerobic              | 1.2-32       |
| Radiolysis              | Cellulosics                       | 0.002-0.012  |
|                         | composite                         | 0.002-0.006  |
|                         | PVC                               | 0.01-0.08    |
| Corrosion               | Mild steel<br>(anoxic conditions) | 0.0-2.0      |

From Reference 32

Of the remaining two processes, radiolysis is the more significant in the majority of cases, although corrosion has been proposed to explain the apparently unexpectedly high hydrogen gas production rates in certain RFP wastes under anoxic, wet container conditions (Ref 33). As a result, the debate over the need for, and advisability of venting Type A and

TRUPACT packages to achieve control over hydrogen generating wastes is based on the current data and understanding of hydrogen generation by radiolysis in TRU waste forms rather than any other mechanism.

### 3.3.2 Radiolysis in TRU Waste

Alpha irradiation of waste matrices often results in higher gas yields than beta-gamma irradiation apparently due to the high percentage of energy deposited and possibly the high density of ionization associated with alpha tracks. Empirically, the alpha radiolysis process can be described by the number of gas molecules released for each 100eV of alpha energy deposited. The gas generation parameter is called G (gas). For  $G(\text{gas}) = 1.0$ , each decay of  $^{241}\text{Am}$  should yield  $5.48 \times 10^4$  gas molecules, while for  $^{239}\text{Pu}$  the yield per disintegration would be  $5.14 \times 10^4$  molecules assuming 100% of the energy is deposited in the waste.  $G(\text{gas})$  is not an intrinsic property of the material in which a given transuranic radionuclide is mixed, although some waste matrices do clearly show tendencies toward higher G-values than others. Work by Zerwekh (Ref 34) has shown that cellulose and polyethylene evolve more gas than do rubber compounds during radiolytic decomposition. While some researchers have been tempted to conclude that gas yields in a small sample of typical TRU waste (Fig 3, which shows hydrogen generation rate as a function of watts deposited per kg of waste) show satisfactory consistency within each waste category (Ref 33), others have observed a wide range in G (gas) values within various waste categories.

The gas yield (G) has been observed to vary with time (or, equivalently, integrated dose) for a given TRU waste. This aspect has very important implications for the prediction of gas

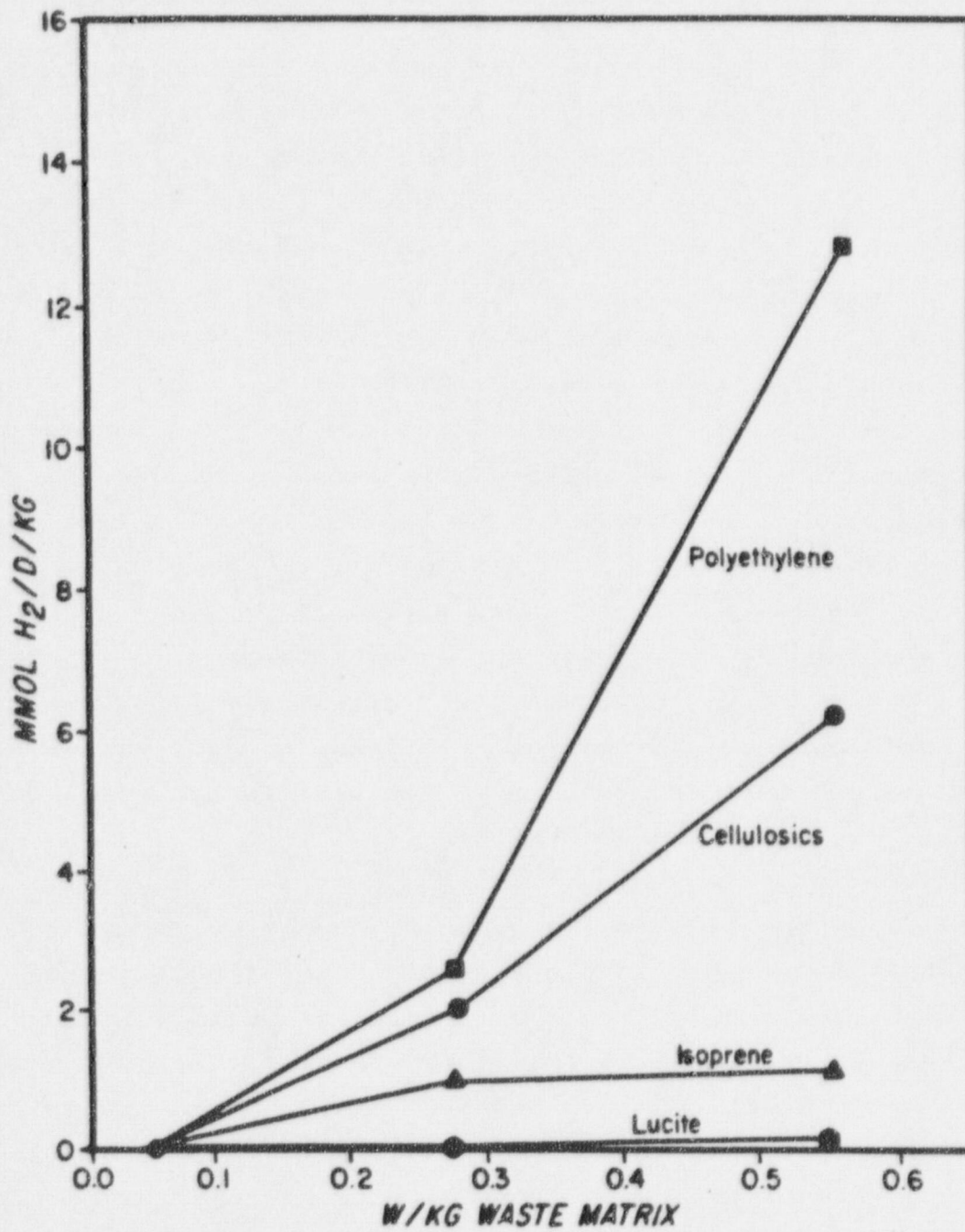

Figure 3. Hydrogen generation in experimental waste matrices (from ref. 33).

formation. In the Clements and Kudera study of gas yield, for example, an average G value was calculated for a number of waste forms over a 13-week period (Ref 33). Over a 13-week period, large changes in G (gas) may occur in some waste forms. Averaging over such a long time tends to smooth peak and low values. There may be very significant consequences resulting from even short-term high gas yields. Although the causes for changes in gas yield are not completely understood, the most likely explanation for the decrease of G (gas) with time in most waste forms is matrix depletion. Matrix depletion may result from changes in contact between contaminated surfaces and organics in the waste, transformation of the matrix due to radiation effects, and loss of suitable hydrogen bond sites within the range of alpha particles from contaminant sites. An example of extreme matrix change brought about by radiolysis is the observed formation of a fine powder by radiolytic degradation in cellulosic waste forms and neoprene drybox glove material (Ref 34). The powder contained approximately 50% of the TRU contaminant that was added originally. Powder formation may contribute to the changes in G (gas) in such wastes, but this has not been demonstrated. Few other waste matrices showed similar degradation products.

In six experimental studies, long halftimes of decay of G (gas) have been observed. In the case of a mix of cellulose, plastics, and rubber (Fig 4-a), the halftime is 630 days. For water-soaked cellulose (Fig 4-b), the halftime is nearly 10 years (3465 days). On the basis of the data from these studies, it is tempting to conclude that any change in G (gas) value would not be of interest as far as implications for transportation are concerned (30-60 days), and that an average G (gas) determination over a period of several months could suffice to quantify the amount of gas generated.

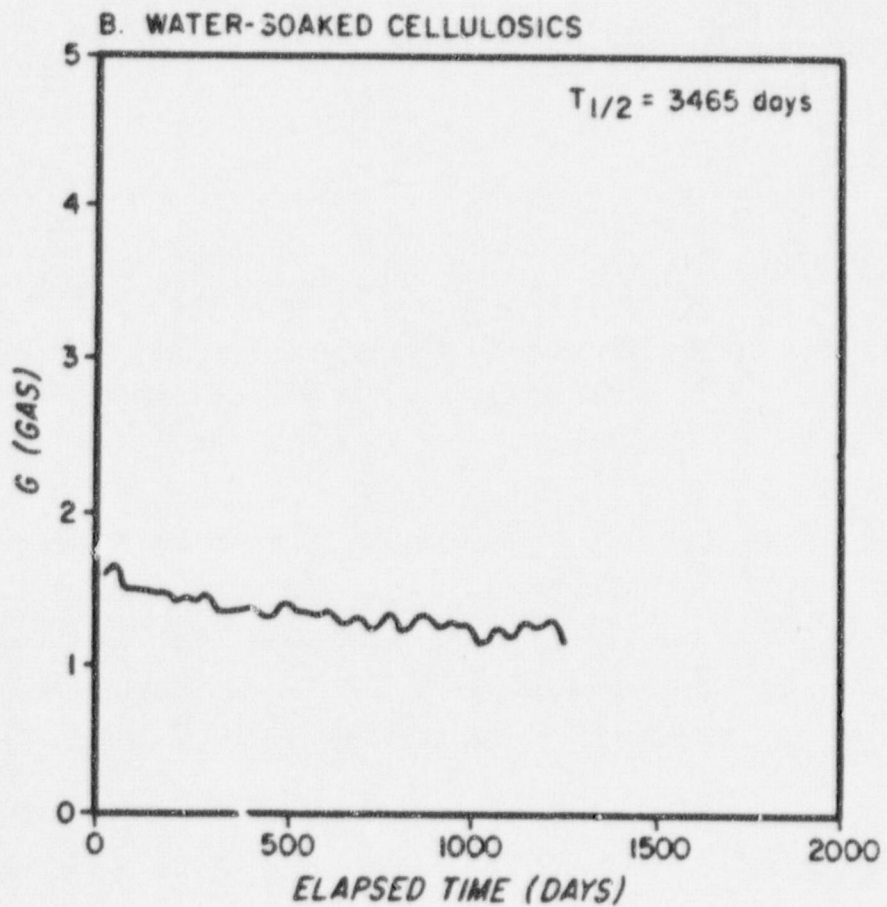
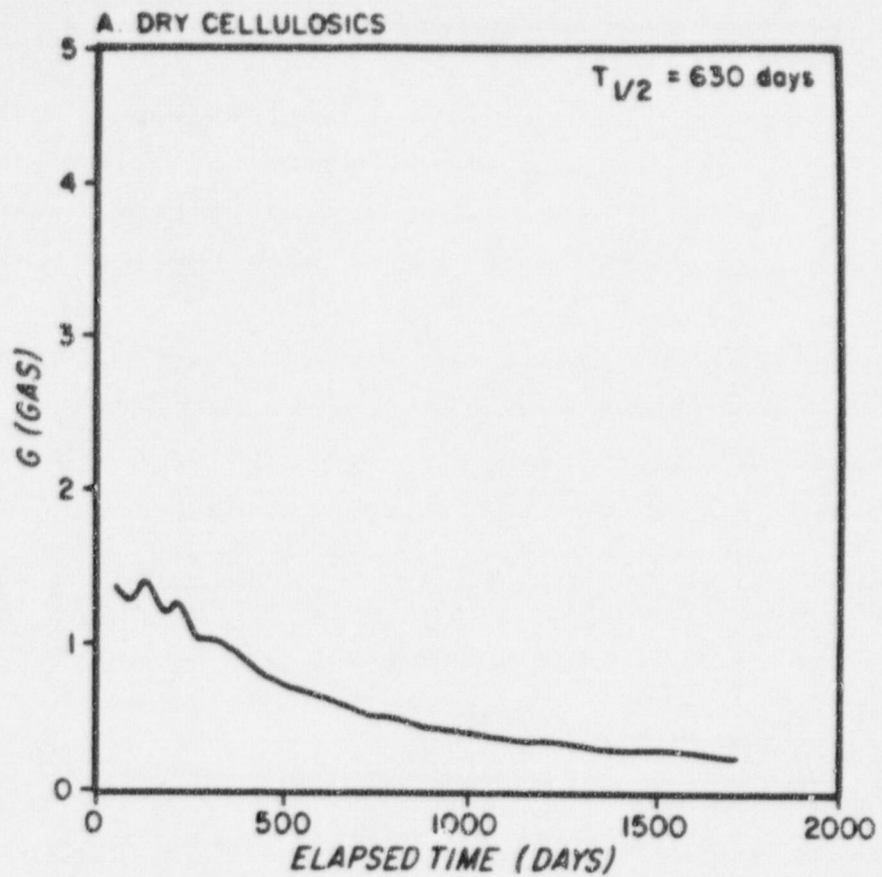

Figure 4.  $G$  (gas) as a function of time (from ref. 34).  $G$  = gas molecules per 100 eV.

However, as a result of our recent reviews of data on gas generation in a sample of RFP waste forms (Ref 33) and models of gas generation in sealed and vented packages (Ref 36), a different perspective on G (gas) has emerged.

The initial gas generation rate G (gas) can be much higher than the average as shown by the post-closure data of the TRU waste package (Ref 35). Figure 5 is a plot of G (gas) against energy released (eV). Note that a non-standard use of the term "dose" occurs in this literature. Here it means energy released rather than the usual energy deposited per gram. For short times (low dose) the G (gas) value is nearly 3, and later decreases to 1. A similar pattern of initial short duration, high G (gas) value, followed by a nearly constant long-term G (gas) value, has emerged from our analysis of the recent RFP study data. Using a hydrogen diffusion model described below (also see Appendix A), the data for hydrogen buildup in vented drums was modeled. The best overall fit was obtained assuming a two component model of G (gas) as a function of time:

$$G(\text{gas}) = G_{\text{Initial}} \text{Exp}(-\lambda t) + G_{\text{constant}}$$

where  $\lambda$  is a relatively short term decay constant. No doubt there are other possible models that would fit the data, particularly a double exponential model where the constant term is replaced by a constant plus exponential.

The resultant G (gas) parameter, shown in Figure 6, has the short-term declining G-value and a long-term constant G-value. The figure also illustrates that the function is consistent with a measured 13-week average G-value which is much smaller than  $G_{\text{Initial}}$ .

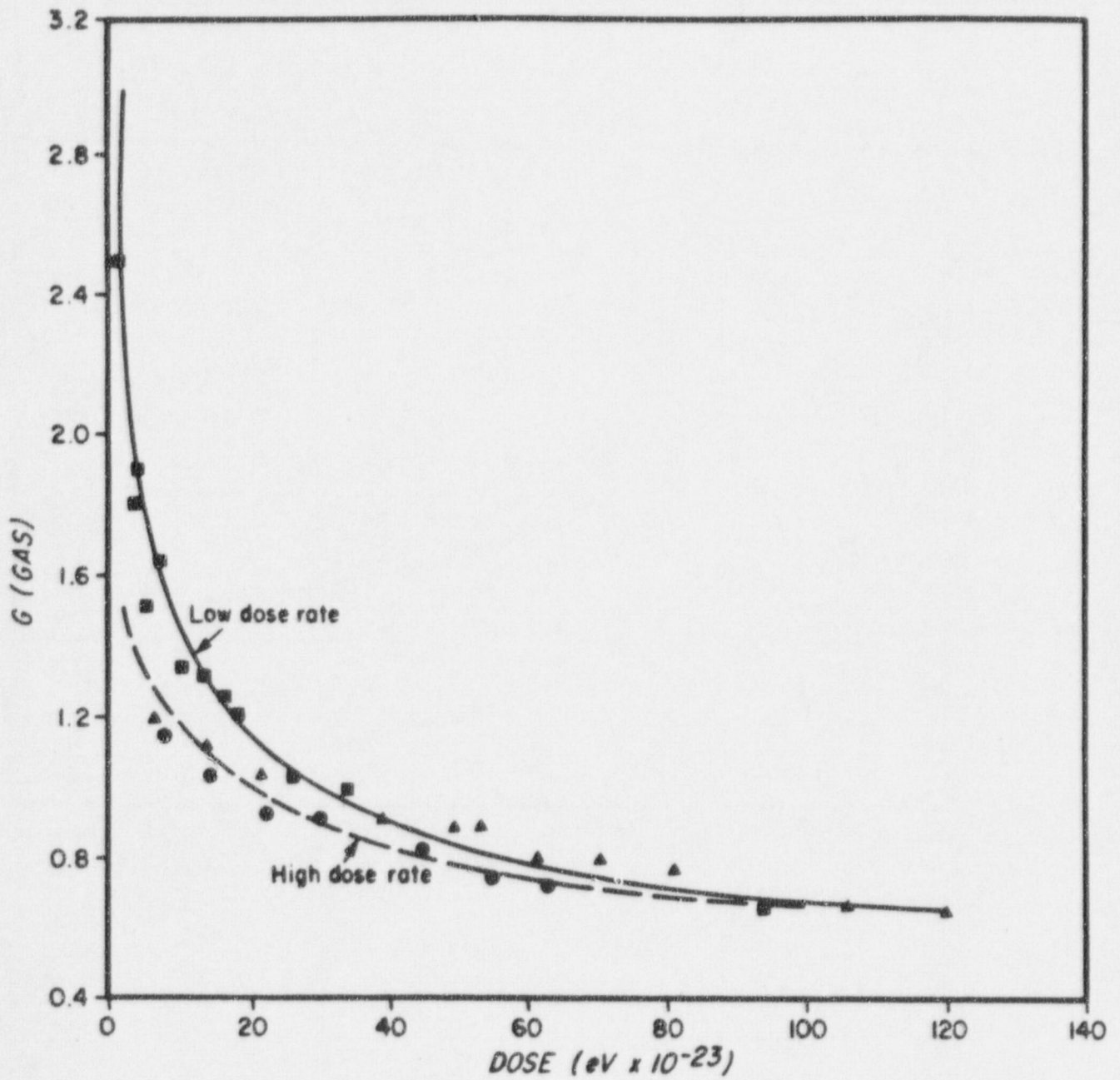

Figure 5. G (gas) as a function of integrated dose (from ref. 35).

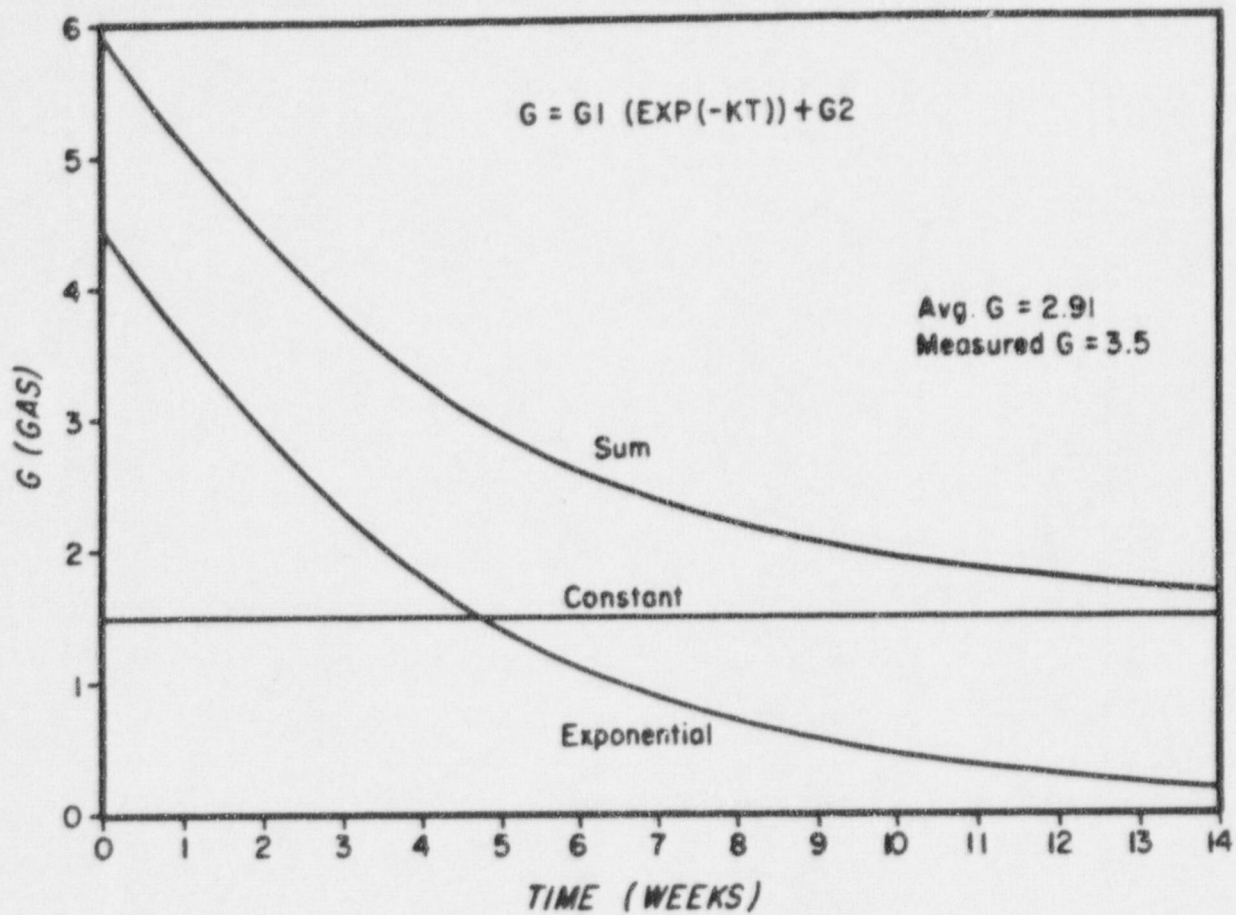

Figure 6. Two component  $G$  (gas) time-variant function.

As partial confirmation of the general correctness of this approach the dose, again, in the non-standard sense of energy released into the waste, for one of the cellulosic waste drums was computed, and G (gas) predicted by the model vs dose was plotted (Fig 7). Although the predicted G (gas) was higher for this case, the overall shape is quite similar to the curve from the experimental data. The G (gas) and G (hydrogen) parameters were measured in the RFP experiments by successive one-week determinations of the changing hydrogen partial pressure in sealed drums. A separate set of measurements was made when these drums were vented. Therefore a limited comparison between modeling predicted G (hydrogen) behavior and observed G (hydrogen) changes in the sealed drum can be made. As seen in Figure 8, there is reasonably good agreement between these two estimates. However, as Figure 9 illustrates, in some cases the apparent initial G (hydrogen) is very much larger than the average. There is considerable uncertainty about the exact time the first reading was taken post-sealing ("time-0" in the data set), which has a large effect on estimated G (hydrogen) during the first week. Only more detailed measurements of the initial phase of hydrogen generation will resolve the question of whether a large initial G (hydrogen) occurs and if that results in a rapid filling of the drum void with hydrogen.\*

---

\* There are a number of potentially viable alternative explanations for the observed rapid initial rise in hydrogen concentration. One possibility, applicable to waste consisting of a number of separate sealed plastic bags of waste in a drum, is that G(gas) is nearly constant, but when purging occurs before sealing a drum, a large remnant hydrogen concentration remains in the several bags, which then quickly diffuses into the drum void post-sealing. In monolithic waste forms hydrogen diffusion from the core may cause a similar short term response.

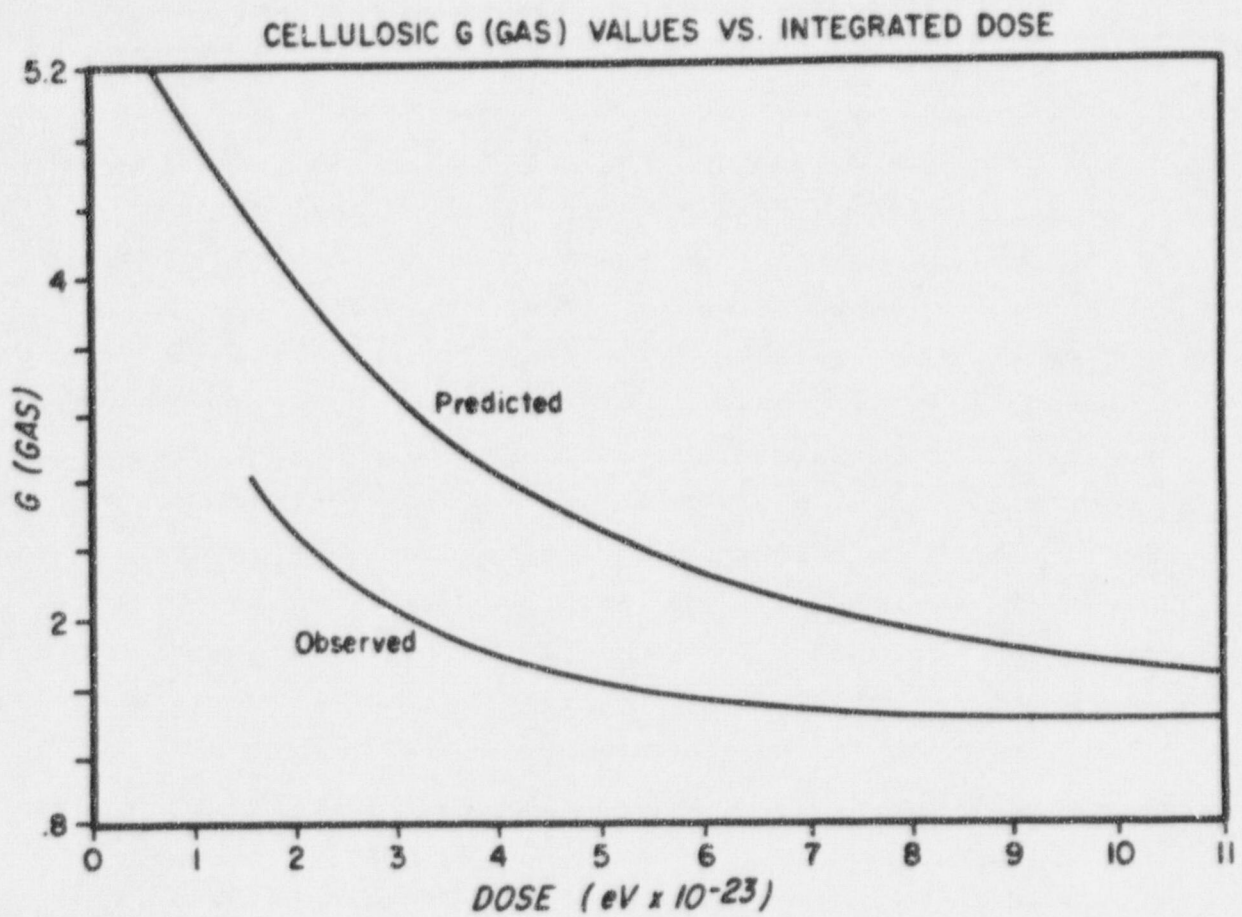

Figure 7. Model predicted G (gas) variation with integrated dose (from ref. 32).

G (HYDROGEN) IN DRY COMBUSTIBLE WASTE  
(DRUM 24545)

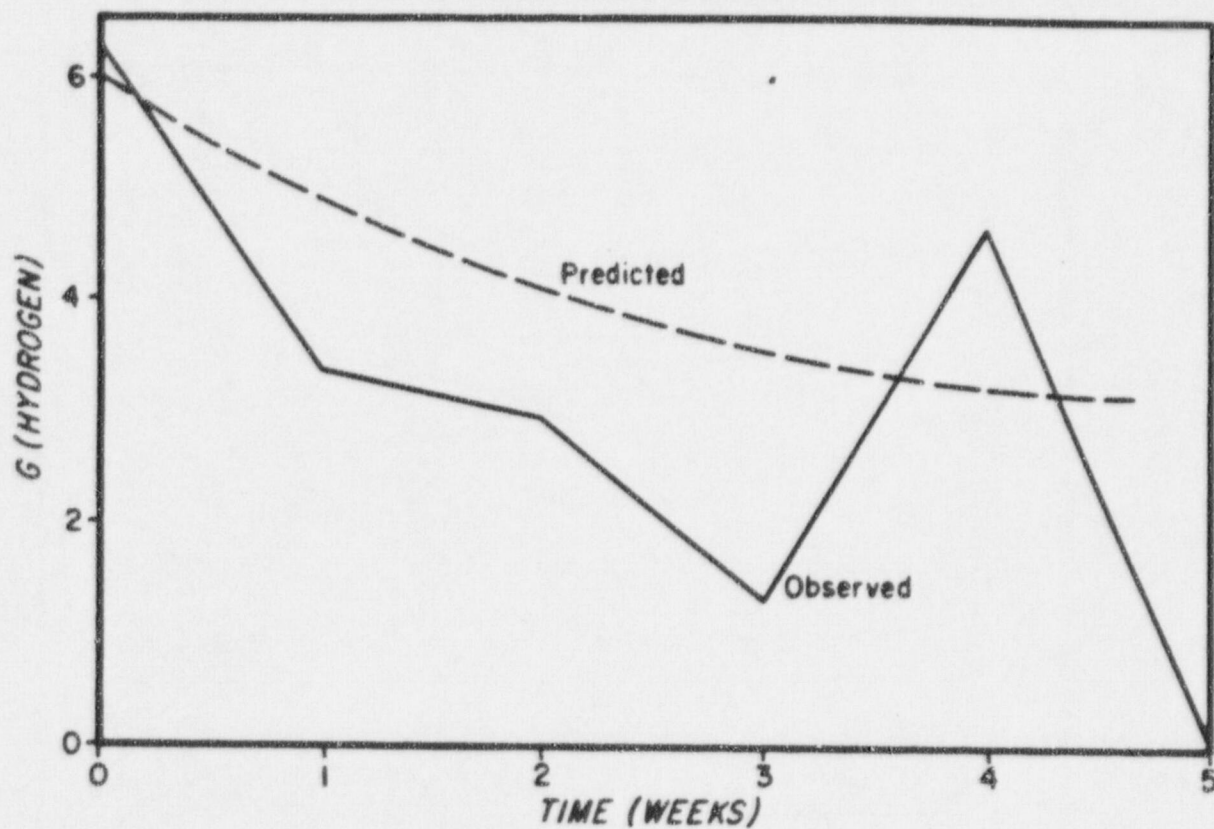

Figure 8. Modeled and observed time varying G (hydrogen) in a sealed RFP drum of TRU waste.

G (HYDROGEN) IN COMBINED SLUDGE  
(DRUM 29258)

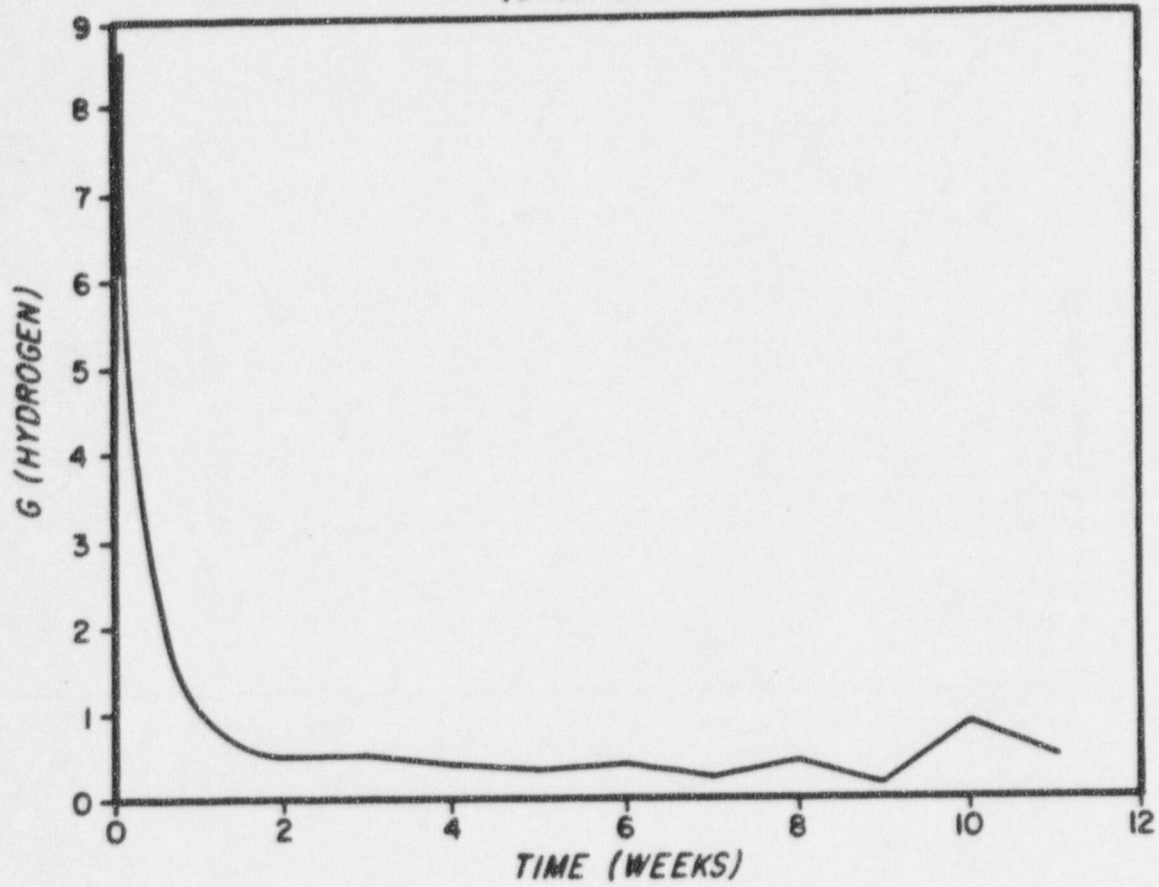

Figure 9. Observed time-varying G (hydrogen) in a sealed RFP drum of TRU waste.

Thus the process of generation of gases in TRU wastes, particularly flammable or explosive mixtures of hydrogen, is quite complex, particularly in the initial period following purging of the drums and installation of vents. It has been shown here that the G (hydrogen) parameter can be described as a two-component exponential function of time. The long-term component may be a constant, or have a large half-time (2-10 year half life) compared with the short-term component (0.5 - 3 week half life). The short term component is at least sometimes associated with an apparently very large G (hydrogen) compared with the long term average value. As mentioned in the footnote to the previous paragraph, the apparent high G (hydrogen) may be due to other processes at work. It is the effect, of course, which is of real concern.

Given these characteristics of G (hydrogen) and G (gas), the next question to address is how the formation of flammable or explosive mixture in shipping containers and the TRUPACT can be avoided.

### 3.3.3 Controlling Pressure and Hydrogen Buildup

Given that some wastes will rapidly evolve large quantities of hydrogen gas, and the obvious desirability of controlling pressure and flammable gas buildup in transport packages, it is clear that some form of control is needed. There are four principal options to consider:

1. Recombining hydrogen and oxygen with catalytic recombiners;
2. Using getters to trap the hydrogen gas;

3. Venting the containers and the TRUPACT; and

4. Management control.

Management control includes purging of the inner waste packages with inert gases just prior to shipment, and controlling the shipping time so that concentrations of hydrogen and oxygen remain below 4% in transit. The NRC approach to regulating transport of hydrogen generating low-level wastes involves management control [Ref 40].

The first option, recombining hydrogen and oxygen, has been used on a large number of drums of transuranic waste at Hanford, and has been used with the Three Mile Island (TMI) hydrogen generating wastes (Ref 37). A disadvantage is that corrosion or other oxidation processes may compete for oxygen, leaving an unacceptably high hydrogen concentration. The use of hydrogen getters is apparently an untried option at Hanford and at TMI at this time and will be discussed further below.

The third option, venting, has received the most attention by DOE. The concept which has been most thoroughly investigated involves venting the waste packages through rugged high efficiency filters or permeable gaskets and vent clips so that gases are released. Particulates are supposed to be retained in the containers even under severe transport conditions. Figure 10 (a) illustrates the small filter (RFP bung filter) being considered by DOE for Type A packages, and 10 (b) the filter design which has been proposed for the TRUPACT (if it is vented). The prime consideration is whether venting will provide the needed control of hydrogen concentrations in Type A packages and the Type B TRUPACT under the actual transport conditions of the waste forms and TRU concentrations anticipated

A. ROCKY FLATS PLANT SMALL BUNG FILTER CONCEPT  
HOLE AREA = 0.079 cm<sup>2</sup>  
EFF. THICKNESS = 13.24 cm

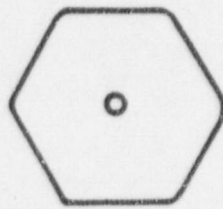

1/8" vent



1"

B. TRUPACT I PROPOSED FILTER

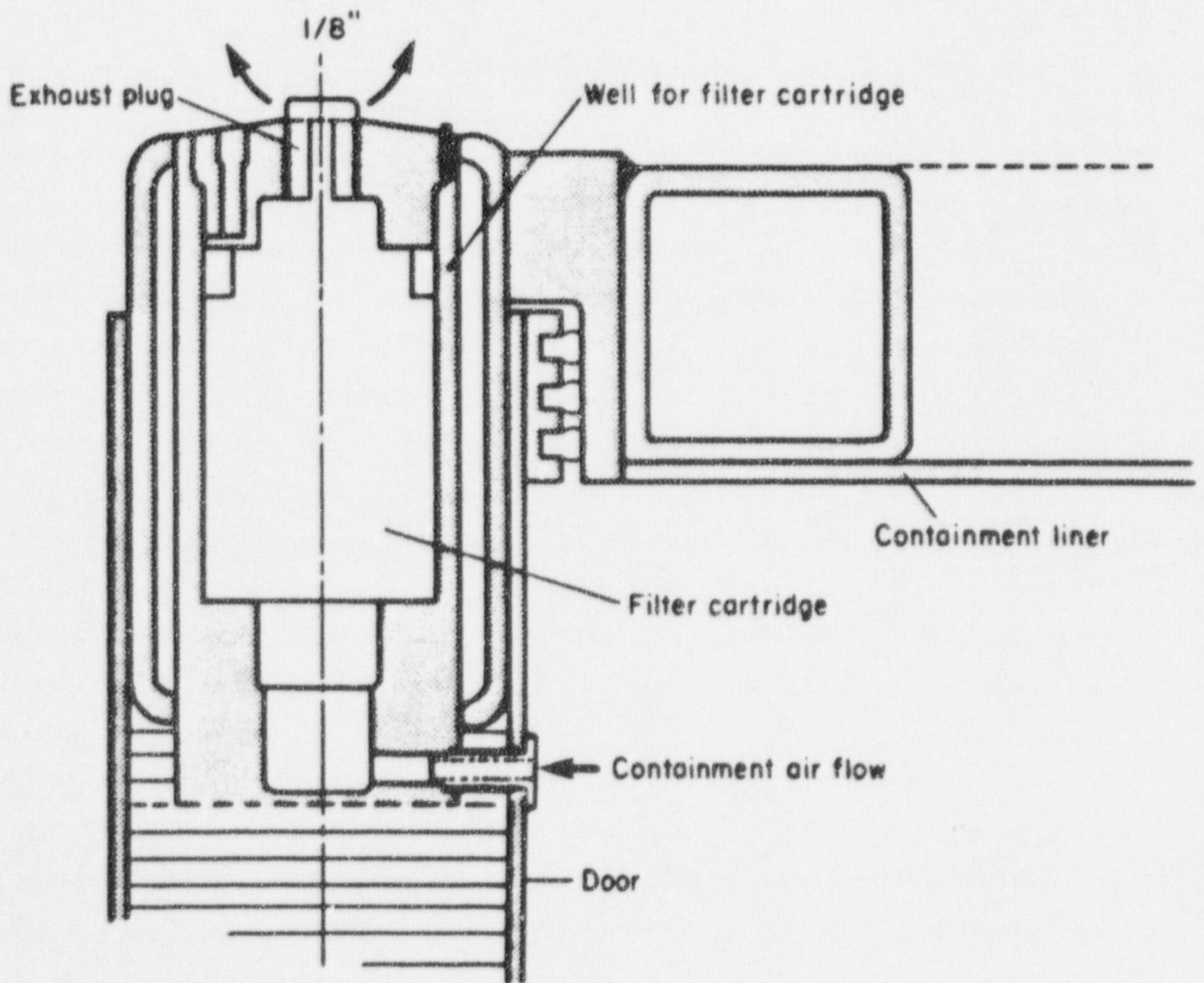

Figure 10. Filter vent concepts.

in defense wastes to be shipped to WIPP. DOE has supported a number of research efforts aimed at understanding how venting of Type A packages may serve to control hydrogen buildup. As a result, there is a growing body of data on the performance of venting devices such as the RFP bung filter under storage conditions, which indicates that at relatively low curie loadings, venting will maintain drum concentrations below 4-5 percent hydrogen (Ref 33). Although there are some experimental vent performance data for higher drum loadings, none are available for a fully loaded TRUPACT. Thus computer modeling must be used to provide performance predictions for the TRUPACT. There is a definite need for confirmatory data for these model predictions.

#### 3.3.4 Modeling of Hydrogen Gas Buildup

A recently developed computer model of hydrogen dissipation in sealed or vented, nested transport packages by SAIC (Ref 36) provides a tool for accomplishing these performance predictions. EEG has made a number of modifications to this model which have made it possible to use the approximate diffusion properties of the filters in the model instead of empirically developed effective diffusion coefficients. The EEG modified hydrogen gas buildup model approach to modeling filtered vents parallels Kazanjian's 1983 work (Ref 38) and is described below.

The TRUPACT container geometry is shown in Figure 11. The inner volume represents the Type A packages containing TRU waste. In the case of a fully loaded TRUPACT with 36 55-gallon drums, the inner volume represents one of these drums and the outer volume represents 1/36th of the TRUPACT void when loaded. Each volume is assumed to have a filtered vent, with characteristic thickness and area. Vents can be modeled as sealed as well as

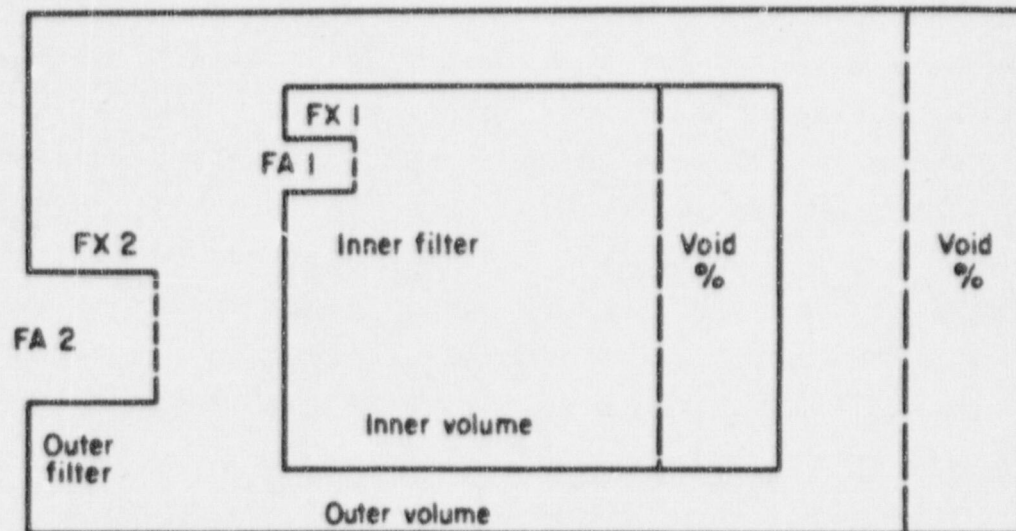

Figure 11. Schematic of drums inside TRUPACT.

open. For simplicity, gas sources are assumed to exist only in the inner volume.

Using the previously described two-component model of G (gas), and the described dimensions of the RFP bung filter (Ref 39), G (gas) values were fit to observed hydrogen buildup data (Ref 33) for a number of cases. For the case of dry cellulose, values of G (gas) were found which fit the observed vented drum data (Fig 12b) quite well. A maximum G (gas) of 4.5 was required, and an average of 3.5. The observed G (gas) for this case was 3.7. Using these same values for G (gas), the sealed drum case was simulated, again with good results (Fig 12a). These are independent data sets, and thus provide verification that the general modeling strategy is sound. More precisely, it should be said that this is a reasonable representation of the phenomena, even if the physical mechanism is the diffusion of hydrogen out of sealed inner voids.

Other cases were simulated, illustrating that the model can be used to predict hydrogen ingrowth in cases where the initial G (gas) is low (Fig 13a), as well as when it is quite high and of short duration (Fig 13b).

The experiments at RFP with actual drums of TRU waste have shown that venting with the RFP bung filter does limit the accumulation of hydrogen to levels below those found when the drums were sealed. On the basis of these experiments, then venting alone will maintain concentrations of hydrogen below 4% if the product of G ( $H_2$ ) and  $\alpha$ -curies is below about 40 (Ref 33). Unfortunately, as was noted in the RFP experiment, no drums were tested for hydrogen generation rates of 20 to 60  $\alpha$  CiG( $H_2$ ) to confirm their prediction.

A. SEALED DRUM HYDROGEN ACCUMULATION IN DRY COMBUSTIBLES (DRUM 24545)

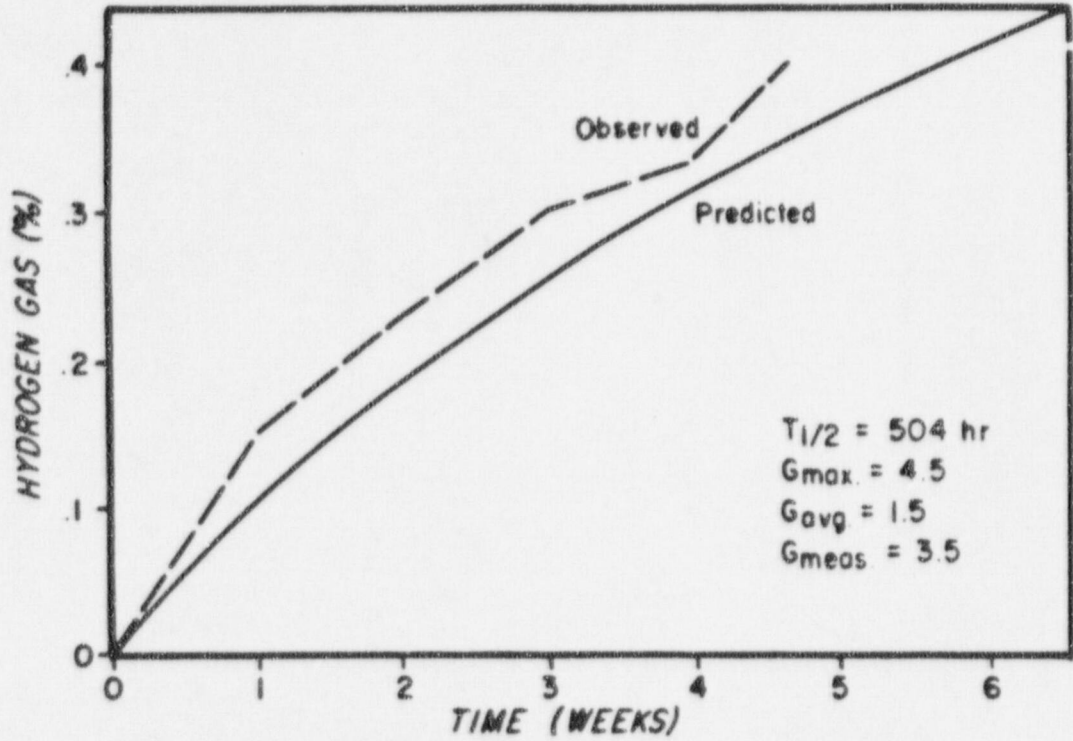

B. VENTED DRUM HYDROGEN ACCUMULATION IN DRY COMBUSTIBLES (DRUM 24545)

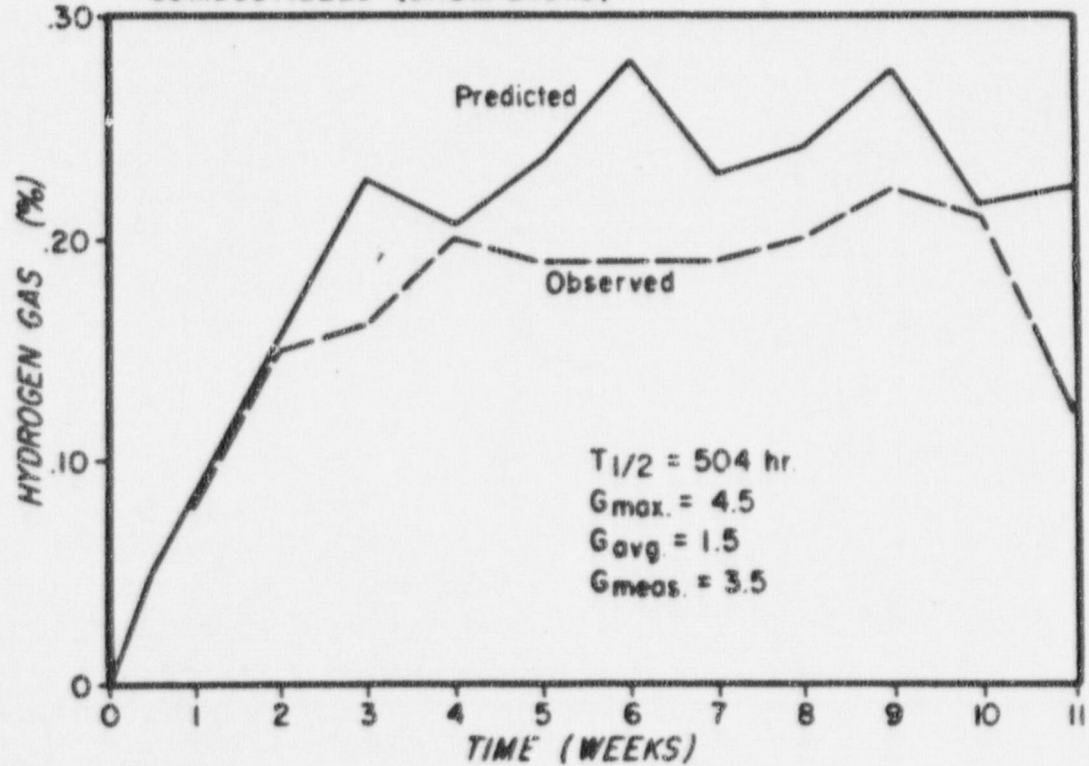

Figure 12. Model verification results.

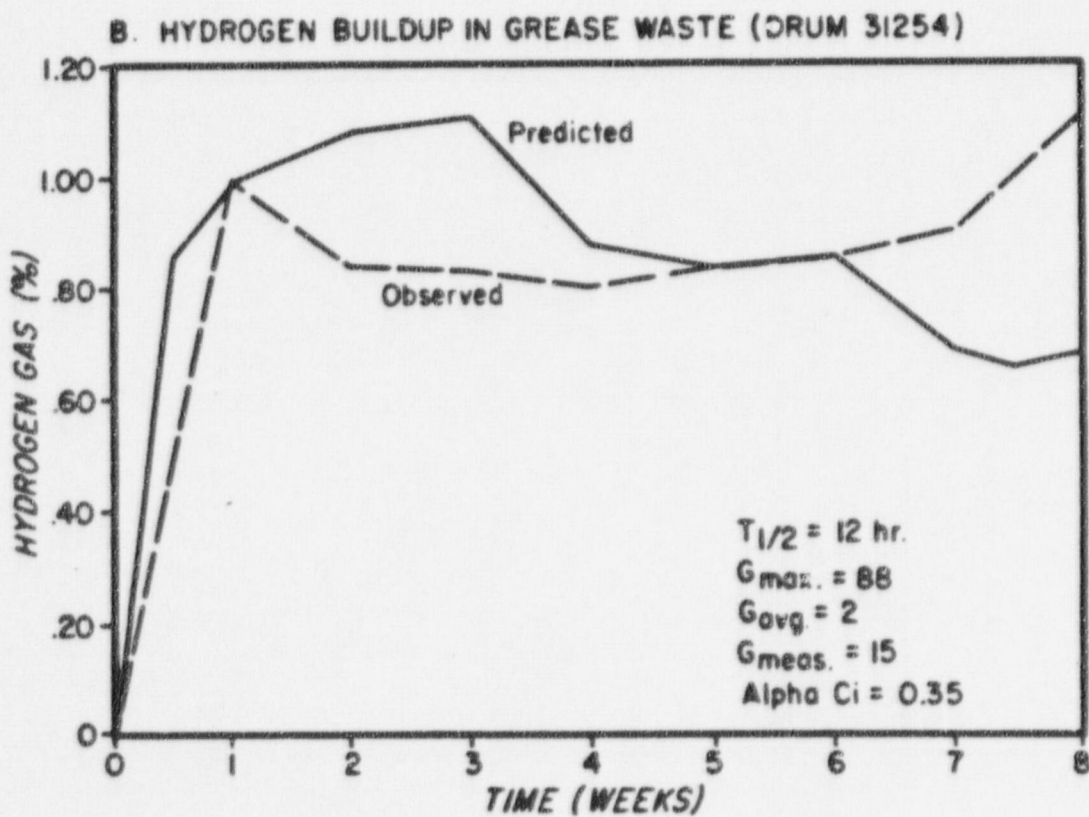
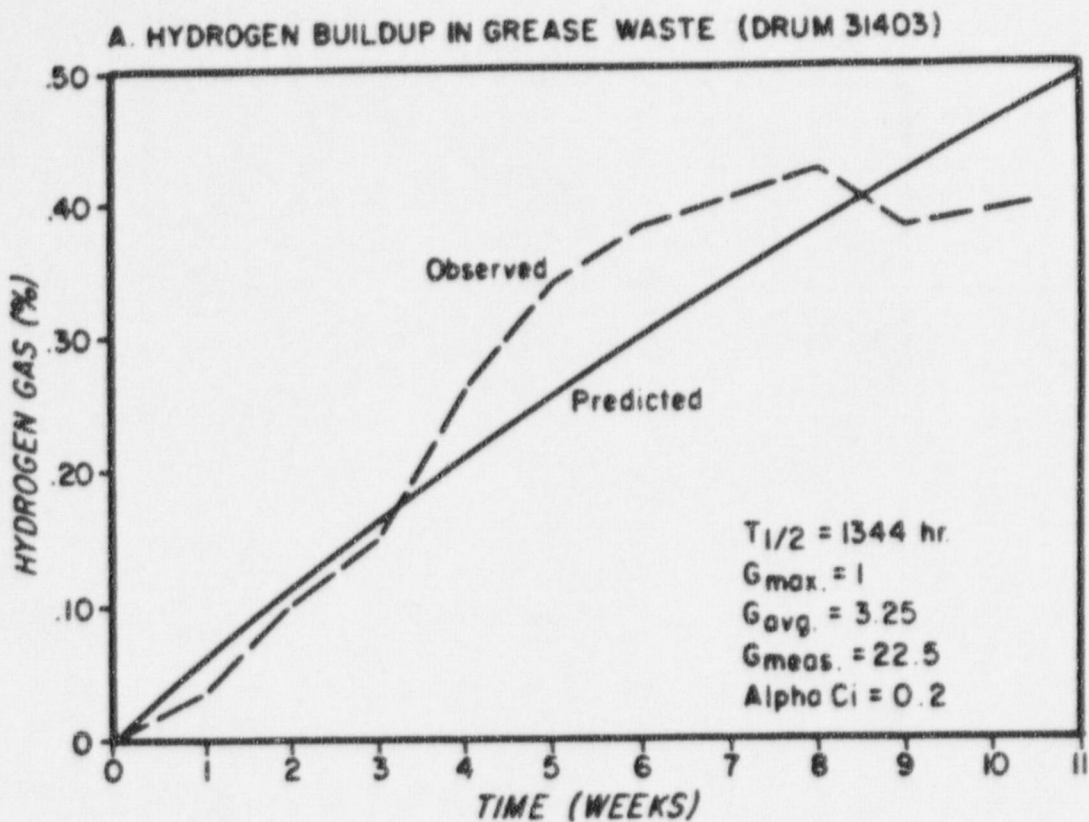

Figure 13. Hydrogen buildup in vented drums.

By modeling, we have attempted to examine the predicted efficacy of venting. If the case of dry combustibles where  $G$  (hydrogen) = 2.1 is extended to the maximum controllable loading by the Clements and Kudera method, the allowable loading would be 20 curies and the 4% limit would be exceeded in about 3 weeks. Furthermore, if 36 of these drums were loaded into a vented TRUPACT, concentrations would reach 4% hydrogen in 6 weeks. (See Figure 14).

It has been suggested (Kazanjan) that at higher curie loadings a larger filter would be required to limit hydrogen concentration. The results of our modeling, however, indicate that a 28-fold increase in filter area would be required to achieve a 30% reduction in hydrogen concentration. A filter this large would risk a reduction of containment integrity.

Our perception of the venting process at this time is that during the initial post-closure period following purging, the relatively rapid buildup of hydrogen concentration either due to high initial  $G$ (hydrogen) or the presence of hydrogen in sealed packages diffusing into the void, or both, quickly displaces air from the void space without a large loss of hydrogen, since the initial hydrogen concentration gradients are small. But then as the hydrogen concentration builds, even though the hydrogen contributions from various sources may drop to modest levels, the hydrogen concentration can rise to the flammable or explosive limit if the curie level is high enough. A critical factor in the process just outlined is the occurrence of an initial high influx of hydrogen, even for a few hours or days.

While such initial high rates of hydrogen gas input can be expected, confirmatory experimentation is definitely needed. Based on data developed thus far, and our current modeling

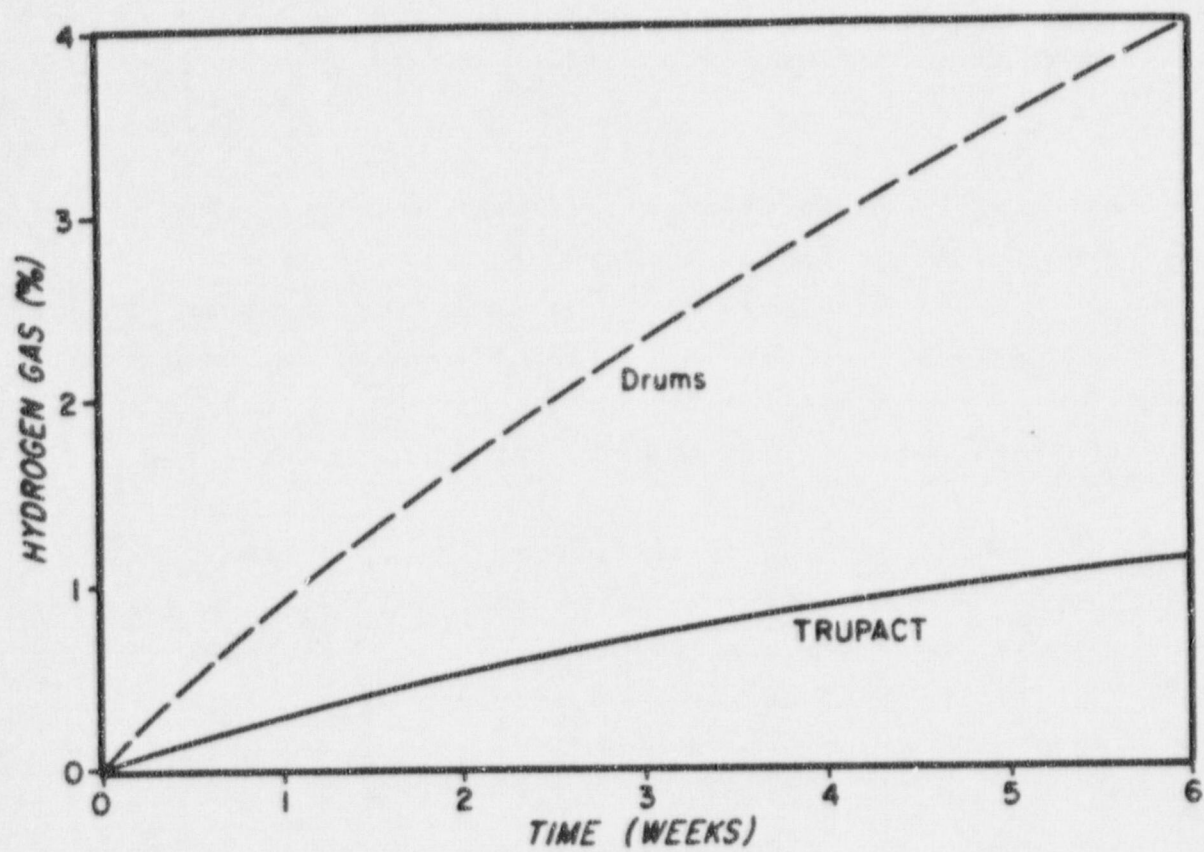

Figure 14. Vented TRUPACT with 36 drums (20 Ci/drum).

results, we conclude that venting of the Type A and Type B (TRUPACT) waste packages to achieve hydrogen control is not likely to result in the desired effect for a significant portion of the present defense TRU inventory and thus should not be relied upon as a control mechanism, particularly if a relatively inexpensive and effective alternative control practice is available.

### 3.3.5 Alternative Control Strategies

Fortunately there are alternatives to the venting of transport and storage packages in order to achieve control over the formation of flammable or explosive mixes of gases. Many of these are currently in use in the handling and transport of high level wastes, both in the defense (Ref 37) and commercial sectors. These practices all rely on the outer (Type B) package not being vented, which has the obvious advantage of conforming with NRC and DOT regulations.

A strategy for the storage, preparation for shipment, and transport within controlled time limits following sealing of waste packages must be developed by DOE to properly implement a sealed TRUPACT shipping system compatible with gas generating wastes.

Components of such a strategy are expected to include:

1. Identification of wastes requiring special handling to control gas generation:
  - a) Methods for computing  $H_2$  and  $O_2$  generation rates in various waste forms, particularly short-term high hydrogen evolution rates, based on waste forms, curie content, internal packaging, etc.

- b) Methods for confirming gas generation buildup (through QA programs).
2. Treatment of Gas Generating Wastes:
- a) Venting gases from drums which have been in storage.
  - b) Installation of filtered vents, permeable gaskets, or other systems which will allow drums to continue to vent during storage and transport.
  - c) Dilution of drum voids with inert gases prior to sealing.
  - d) Introduction of hydrogen-oxygen recombiners or, perhaps better, hydrogen getters in the drum void.
3. Provision of Administrative Controls:
- a) Identification of special problem wastes.
  - b) Creation of control system to track storage and shipment times after closure of the containers and the addition of getters or recombiners to assure wastes can be handled and transported to WIPP without the buildup of excessive levels of hydrogen.
  - c) Creation of a data base on waste forms, G-values, alpha-curie content, etc. for predictive purposes and QA.

Regarding the first of these components, NRC's Office of Nuclear Materials Safety and Safeguards (NMSS) has provided some guidance on how to deal with shipment of wastes subject to hydrogen generation (Ref 40). This should provide valuable guidance for the DOE TRU wastes as well. The generic requirements specify that for gas generating wastes it must be

determined by "tests and measurements of a representative package" that hydrogen and oxygen concentrations do not exceed 5% by volume during a period of time that is twice the expected shipment time. More recently NRC has recognized that an analytic approach can be effective as a means for determining gas generation (Ref 41). Thus a valuable tool for control is a flexible, well-tested, and peer-reviewed hydrogen generation and control assessment methodology and associated data base. The analytic approach involves determining the hydrogen generated in the waste by radiolysis during a period of time after closure and twice the shipping time. This requires determining well the properties of waste influencing gas generation by suitable tests and measurements on representative waste forms (such as those reported by Clements and Kudera in Reference 33). A valuable refinement of this modeling approach would be the provision of capability to estimate hydrogen contributions from sealed inner packages as an alternative, or contributor to, observed high G (hydrogen).

The second component, venting, has been extensively discussed above, but  $H_2-O_2$  control by recombiners or getters warrants further discussion. Catalytic recombiners remove hydrogen and oxygen in the ratio of 2-to-1. However, when oxygen is being scavenged by oxidation of the drum or waste components, excess hydrogen can build up. If oxygen is sufficiently limited, there is not a high hazard from flammability, but there is a potential for ignition upon venting to the atmosphere. Catalytic recombiners seem to be most appropriate under conditions of relatively short term storage post sealing and purging of drums. An existing individual package recombiner packet design is shown in Figure 15. Hydrogen and oxygen diffuse to the catalyst where they recombine to form water vapor. The vapor condenses on colder surfaces in the system. A combination of Engelhard

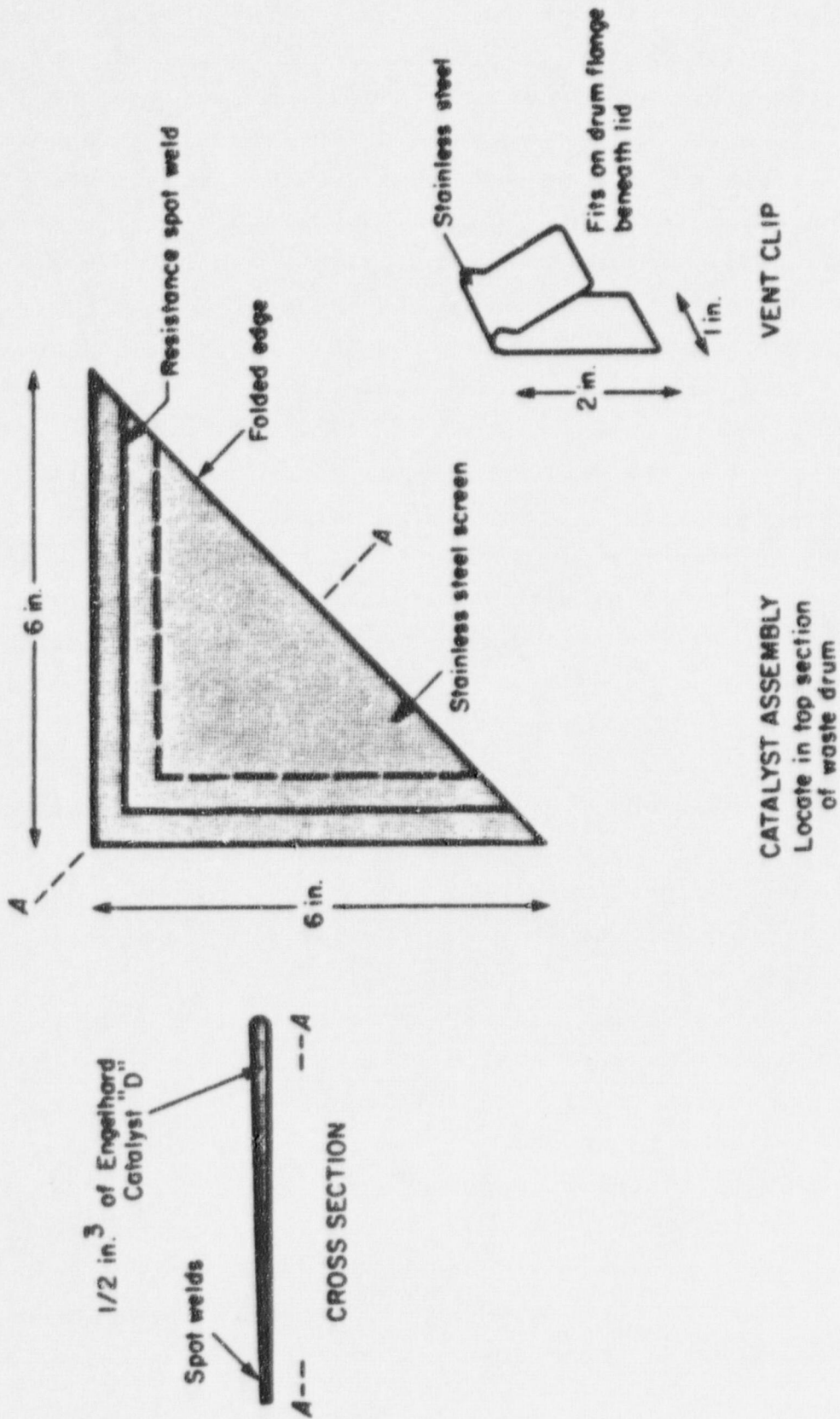

Figure 15. Rockwell Hanford operations catalyst bed and vent for drums of radioactive waste.

Dextro D and silicon coated catalysts have been found to be effective under both dry and wet conditions (Ref 37).

Hydrogen getters, in contrast to recombiners, selectively remove hydrogen by chemical reaction regardless of oxygen concentration, and thus do not have the limitation of susceptibility to competing processes for removal of oxygen. One potential getter is propargyl ether mixed with a metallic catalyst. Details on this getter are described by Neary in Appendix B. Others are described by Trujillo and Courtney (Ref 42). One disadvantage of getters is that they are consumed in the gettering process. Thus, careful consideration has to be given to the total amount of hydrogen expected to be generated during the storage and shipment period so an adequate quantity of getter can be provided. Both recombiners and getters must be properly placed in the transport package. If they were used in the TRUPACT, then there may be some material and labor savings over the construction and placement of individual packets for placement in the drums or boxes. However, a compelling argument in favor of placing the control materials directly in individual drums is that the interaction of hydrogen and getter surface occurs sooner and more efficiently in the drum than in TRUPACT.

If the removal process is limited primarily by diffusion of hydrogen to the active surface, effective control can be anticipated by placing a hydrogen getter (Fig 15) in the drum. It may be possible to spray getter material in sufficient quantity on the inner surface of Type A packages to effectively control hydrogen for the handling and shipping period. A computer model simulation of such a process is shown in Figure 16. A simple representation of the removal by gettering was assumed with only a limited number of sites available (0.5 hydrogen moles equivalent). Without the use of getters, a

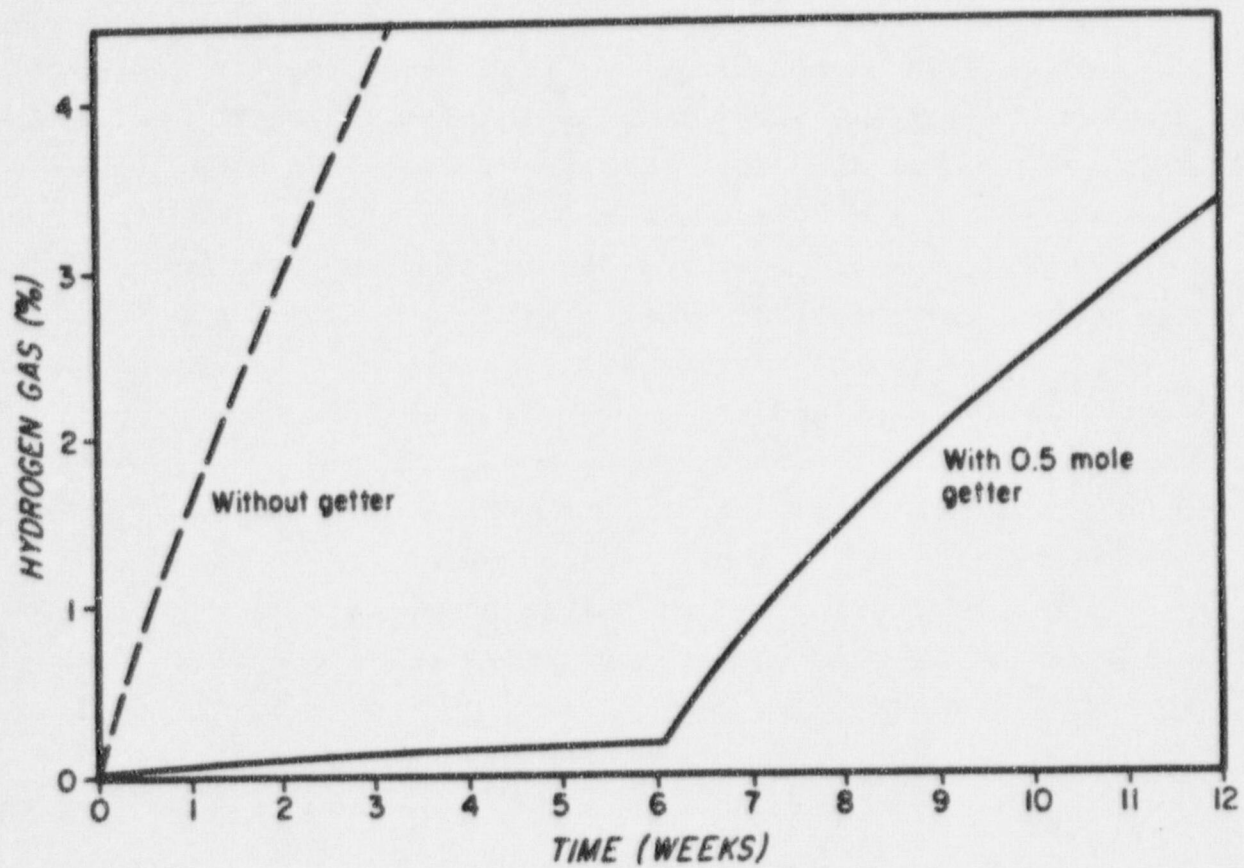

Figure 16. Effects of getter on hydrogen concentration in drums.

flammable level of hydrogen is reached in less than 3 weeks. However, with getters, an additional 3 weeks of very low hydrogen concentrations are realized before the getter is consumed, and several more weeks during which ingrowing hydrogen concentrations are still below four percent.

Similar simulations with the getter assumed in the TRUPACT do not suggest that effective control of hydrogen would occur. In this configuration, hydrogen must accumulate and then diffuse out of the drums and reach the getter or recombiners in the TRUPACT before any removal occurs. Further modeling and experimentation are needed to establish the best control strategy, but placement of getters in each drum appears to be the best control option.

An added advantage of placing the getter or recombiner materials in the Type A package instead of the TRUPACT is that model simulations indicate that where the TRUPACT is sealed, but the drums are vented, flammable mixtures can accumulate in the drums even though the TRUPACT void levels are acceptably low. If the getter is placed in the Type A packages also, control of both containers is achieved, which should be the only acceptable condition for transport and receipt at WIPP.

The third component, administrative controls, is critical to the development of a successful control strategy. If the option of using getter materials to control hydrogen buildup is adopted, it would appear that the more detailed auditing of waste matrix form, curie content, inner packaging characteristics, etc. that would otherwise be required, could be avoided. However, this is an area which requires detailed evaluation by DOE. The issue of special problem waste, particularly high curie content waste, raises other concerns which will be discussed in Chapter 4.

#### 4. HIGH-CURIE CONTENT

##### 4.1 Statement of Issue

The draft TRUPACT Safety Analysis Report for Packaging (SARP) conclusions on the quantities of various TRU waste forms that can be transported in a TRUPACT load are shown in Table 16 (Ref 31).

TABLE 16  
SARP MAXIMUM TRUPACT LOADINGS

| <u>Waste Type</u> | <u>Total Ci</u> | <u>Total (a)<br/>PE-Ci</u> | <u>Limiting Criteria</u> |
|-------------------|-----------------|----------------------------|--------------------------|
| Normal Weapons    | 4,450           | 840                        | criticality control      |
| Am-Enhanced       | 12,020          | 4,340                      | heat generation (360W)   |
| Heat Source       | 11,200          | 14,200                     | heat generation          |

(a) PE-Ci = Equivalent curies of insoluble  $^{239}\text{Pu}$  based on inhalation toxicity (Ref 46).

DOE estimated the bounding consequences that might occur from accidents while transporting TRU wastes to WIPP in Chapter 6 of the Final EIS on WIPP. These consequences assumed a total radioactivity loading on a rail car (containing 126 drums in 3 TRUPACTS) of 79.5 PE-Ci of insoluble TRU wastes. This loading assumed all drums contained an average quantity of TRU wastes. The release fractions and other scenario assumptions used in the FEIS were similar to those used in NUREG-0170 and are considered

typical for nuclear materials transportation. EEG believes that the assumptions were reasonable, but slightly unconservative. The FEIS also stated that the maximum radioactivity in a drum would be 25 times the average value. A railcar carrying two TRUPACTs could contain 28,400 PE-Ci. This value is 357 times that used to calculate bounding consequences in the FEIS and 14 times the implied upper limit in the FEIS.

The key issues are whether:

1. Such a drastic increase in the PE-Ci load of the TRUPACT has such a substantive change in the predicted consequences from Chapter 6 in the FEIS that it should not be permitted without an amendment to the FEIS;
2. The potential hazards of these proposed maximum shipments are excessive compared to other radioactive material shipments.

#### 4.2 Possible Risks and Consequences

##### 4.2.1. Comparison with FEIS

There are numerous differences between the calculations in Chapter 6 of the FEIS and Chapter 2 of this report besides the number of PE-Ci being transported. These include the assumed fractional releases and dose conversion factors (see Table 17).

The PE-Ci of radionuclides released shown in Table 17 is a better measure of the comparative risks estimated in the FEIS and in this report than the dose received by the maximum individual because the FEIS doses were calculated using older dose conversion factors which are not directly comparable to those calculated in Chapter 2. The Table 17 comparison shows

Table 17

COMPARISON OF RELEASES BETWEEN FEIS & CHAPTER 2  
(PE-Ci)

| Accident      | Fractional Release    | Average Railcar Load |          | Maximum Railcar |          |
|---------------|-----------------------|----------------------|----------|-----------------|----------|
|               |                       | Total                | Released | Total           | Released |
| FEIS          | 1.75-4 <sup>(a)</sup> | 8.0+1                | 1.4-2    | 2.0+3           | 3.5-1    |
| Category VII  | 5.0-4                 | 4.7+2                | 2.3-1    | 2.8+4           | 1.4+1    |
| Category VIII | 2.5-3                 | 4.7+2                | 1.2+0    | 2.8+4           | 7.1+1    |

(a)  $1.75 - 4 = 1.75 \times 10^{-4}$

that a maximum Category VII accident releases about 40 times the amount predicted in the FEIS. The Category VII release from an average truck shipment (the most probable mode) is 8 times the projected FEIS release from an average rail shipment. Another comparison (see Table 19) is that a Category VII accident with the average Savannah River Plant truck Shipment (10 PE-Ci/TRUPACT) would release 2-1/2 times that released in the implied maximum rail accident in the FEIS. EEG believes that these estimated releases from a Severity Category VII accident (2% probability of occurrence during WIPP lifetime) amount to a substantive change in the expected impacts of the project.

#### 4.2.2. Comparison with other Radioactive Material Shipments.

Most transuranic waste has so little penetrating radiation that they can be handled without shielding (hence the name contact-handled). Since all high level wastes and spent fuel, as well as some low level waste, require shielding for safe handling.

there is a tendency to think of TRU waste as a benign form of radioactive waste. However, inhalation following an accidental release is a more important exposure pathway than external gamma radiation.

Some of the contact-handled TRU waste shipments coming to WIPP may be as hazardous or more hazardous than shipments of spent fuel or defense high level waste following an accidental release for the following reasons:

1. The TRU radionuclides are much more toxic per microcurie inhaled (which is the more likely pathway resulting from an accident during transportation or operation) than are fission products;
2. Much of the CH-TRU waste being shipped to WIPP will not be as immobilized as spent fuel encased in zircaloy or steel cladding, or defense high level waste (DHLW) fused in borosilicate glass within a steel canister. Thus, a severe accident involving TRU waste could release a higher fraction of the TRU waste container contents;
3. Some of the shipments that may come to WIPP will have an inhalation toxicity inventory (as measured by the number of Annual Limits of Intake) similar to that of a spent fuel assembly (see Table 18). For example, a TRUPACT load of heat source waste at SRP has an average toxicity inventory of about 95% of a spent-fuel assembly and the inventory would require about 970 TRUPACT loads if it is all shipped to WIPP. There would also be some high-curie loads from other laboratories, primarily Los Alamos. The Defense High

Level waste from SRP has a toxicity inventory less than either of the above; one DHLW glass canister is only 49% of the average <sup>238</sup>Pu shipment (Ref 43).

TABLE 18  
COMPARISON OF SPENT FUEL AND TRUPACT RADIOLOGICAL TOXICITY

| <u>WASTE</u>                    | <u>PE-Ci/LOAD</u>     | <u>TRU/SF</u> |
|---------------------------------|-----------------------|---------------|
| Spent Fuel, Rail                | 26,800 <sup>(a)</sup> |               |
| Truck                           | 3,830                 |               |
| Defense High Level Waste, Truck | 1,760                 |               |
| TRUPACT                         |                       |               |
| Maximum, Rail                   | 28,500 <sup>(b)</sup> | 1.06          |
| Maximum, Truck                  | 14,200                | 3.72          |
| WIPP Average                    | 233 <sup>(c)</sup>    | .06           |
| LANL Average                    | 222 <sup>(c)</sup>    | .06           |
| SRP Overall Average             | 1,0 <sup>(c)</sup>    | .47           |
| SRP Heat Source Average         | 3,600 <sup>(c)</sup>  | .95           |

(a) Reference 45 (7 Assemblies/Cask for Rail, 1 for Truck)

(b) Reference 31

(c) Reference 26 for 1 TRUPACT (Truck).

Combining the PE-Ci per shipment for various wastes and the release fractions from SAND 80-2124 (Ref 44) for spent fuel and Chapter 2 for TRU wastes in the TRUPACT leads to the anticipated releases shown in Table 19. These values indicate that in a severe accident even the average TRU waste shipment to WIPP could be expected to release a much more toxic quantity of radioactivity than a spent fuel shipment involved in a similar accident. A doubly contained design is projected to eliminate any release from a Category VI accident (19% probability of

occurrence during WIPP lifetime) and significantly decreased releases from more severe accidents.

TABLE 19  
 RELEASES FROM TRUCK ACCIDENTS  
 INVOLVING SPENT FUEL AND TRUPACT

| Shipment                    | Load<br>(PE-Ci) | Release<br>Fraction  | Release<br>(PE-Ci)  |
|-----------------------------|-----------------|--|---------------------|
| Spent Fuel                  | 3830            | $2 \times 10^{-6}$ (a)   | 0.0077              |
| TRUPACT                     | (b) 3600        | $5 \times 10^{-6}$ VI (c)<br>$5 \times 10^{-4}$ VII<br>$2.5 \times 10^{-3}$ VIII | 0.018<br>1.8<br>9.0 |
| Double Contained<br>TRUPACT | 3600            | 0 VI<br>$1 \times 10^{-4}$ VII<br>$1 \times 10^{-3}$ VIII                        | 0<br>0.36<br>3.6    |

- (a) Reference 44 (credible worst-case accident).  
 (b) Average PE-Ci load from SRP heat source wastes.  
 (c) Reference 2. Roman numerals refer to accident severity category.

The gas generation problem is an additional factor to consider if high-curie loads are to be shipped. As discussed in detail in Chapter 3, there is considerable uncertainty in the ability to predict gas generation rates and to control concentrations of hydrogen to below the 4% threshold for flammability. The potential gas generation problems increase with increasing curie content in a container or in a TRUPACT load for similar waste matrices.

#### 4.2.3. Non-Radiological Considerations

If there were a reduction in the maximum number of PE-Ci that could be transported in a TRUPACT leading to an increase in number of shipments there would be a corresponding increase in non-radiological injuries and deaths as discussed in Chapter 2. EEG questions whether a significant reduction in the limit would result in a significant increase in the number of shipments (see discussion below). At any rate we do not believe the selective trading-off of radiological versus non-radiological risks should be used to justify TRUPACT design and operation criteria.

### 4.3 Operational and Economic Considerations

#### 4.3.1 Re-Packaging

There would be some costs and additional occupational radiation exposure incurred if it were necessary to repackage currently stored waste in order to comply with a significant reduction in the permitted PE-Ci load in a TRUPACT. Otherwise, re-packaging would not be difficult or unprecedented; some drums have been opened and inspected at most generating sites in order to verify drum contents with records and assay results.

EEG believes that little or no re-packaging would be required if the permissible load limit were set slightly above the average PE-Ci content of a generator's waste. The proposed 1,000 PE-Ci limit in the waste acceptance criteria for a drum or box (which EEG believes should be lowered) will require at least one constraint. There are an estimated 250 drums that contain greater than 330 alpha Ci of heat source waste (which would be >400 PE-Ci if the radionuclide were all  $^{238}\text{Pu}$ ) but we are not aware of any greater than 800 PE-Ci (Ref 46). There are two implications of these data on high-curie drums:

1. It clearly would be possible to load a TRUPACT with greater than 14,200 PE-Ci;
2. It should be possible by load management to mix these high-curie drums with weapons waste and lower curie heat source waste drums in order to hold the total TRUPACT load to less than 2,000 PE-Ci at SRP, and much lower elsewhere.

Another possibility, which DOE is considering, is to dispose of the high-curie drums via incineration of waste and incorporating the residue with BHLW for disposal in a HLW repository.

A positive load management program to minimize the total PE-Ci load in a TRUPACT should not be particularly costly because the containers must be assayed separately for PE-Ci content and adherence to other waste acceptance criteria. Following assay, the PE-Ci content is known and the containers can be assembled for (more-or-less) average TRUPACT loads. These average loads would also be preferable at the WIPP site for handling, loading on the hoist, and emplacing in underground storage rooms.

The DOE has refused to commit to a positive load management program, but they have assumed that random probability would preclude two or more above-the-average PE-Ci drums from being involved in several of their transportation, operation, and post-closure scenarios. Since high-curie containers tend to be stored together at the waste generating sites, EEG believes that without a positive program it is not prudent to assume the occurrence of high-curie drums in a TRUPACT or at WIPP is purely random.

### 4.3.2 Number of Shipments

The number of TRUPACT loads shipped to WIPP should not be increased if a maximum limit is chosen which is slightly above the average TRUPACT load at each generating site. Also, since some wastes will be processed at most sites it may be possible to reduce the average concentration per container while carrying out operations that would be done for other reasons.

The average shipment from SRP (1800 PE-Ci) is estimated to carry an accident risk, with the TRUPACT-I design, similar to the credible worst-case spent fuel accident for a Category VI accident and about 2 orders-of-magnitude greater for a Category VII accident. A double contained, average SRP loaded TRUPACT is estimated to be safer than the worst case spent fuel accident in a Category VI accident (4% occurrence probability in an urban/suburban area) and to release over one order-of-magnitude more radionuclides in a Category VII accident (0.3% probability in an urban/suburban area).

From the above considerations it appears that a doubly contained TRUPACT could be permitted to carry the average SRP TRU waste shipment without incurring a significantly greater hazard than would occur from shipping spent fuel by truck. Therefore, limiting the maximum load in a doubly contained, non vented TRUPACT to slightly above the SRP average load should be acceptable and could be accomplished without increasing the number of shipments.

## 5. REDESIGN OF TRUPACT

### 5.1 Modifications Being Considered

A value engineering analysis by DOE concluded that potentially significant total system economies would be possible by making major design changes to the present TRUPACT-I design. This analysis assumed the TRUPACT-II design would have single containment and continuous venting (Ref 47). Changes being considered include:

- (1) Revising the overall dimensions of TRUPACT to increase the capacity from 36 to 48 drums (the number of 112 ft<sup>3</sup> boxes that can be carried is not increased);
- (2) Drastically reducing the weight of the empty TRUPACT in order to increase payloads. This is done by replacing the roller floor with a slip-plate system; using conventional steel banding or plastic stretch-wrap material rather than steel frames to hold 6 drums together in a "6-pack"; reducing the thickness of the inner liner and Kevlar puncture shield; and reducing the amount of dunnage;
- (3) Changing the method of applying foam insulation between the inner liner and the outer skin.

The WIPP Project Office has stated verbally that the full-scale tests conducted on Unit-0 will be applicable to the new design and additional full-scale tests may not be necessary. Also, it is believed that only an amendment to the TRUPACT-1 SARP will be required. The present schedule is to have a draft

amendment to the SARP in the fall of 1986, a final SARP in March 1987, and a certified design in October 1987. First delivery of operating units will be prior to October 1988, when first waste shipments are scheduled. Present plans are to build only two operating units (Units 2 and 3) of the TRUPACT-I design if the new design is accepted.

## 5.2 Possible Radiological Impacts

This report specifically evaluates only the TRUPACT-I design which is expected to be recommended by the Albuquerque Operations Office for certification by DOE in the third quarter of calendar year 1986. Also, it is not certain that a redesign will be recommended and it is not known what specific changes would finally be incorporated. However, since a redesigned TRUPACT appears likely and if construction is implemented as much as 90% of the WIPP fleet could be TRUPACT-II units, EEG believes it worthwhile to point out some preliminary concerns.

Some of the advantages and disadvantages of a 48-drum TRUPACT were evaluated and discussed in Chapter 2. Radiological effects from routine operations are slightly worse for the 48-drum design and accidental releases from an average load would also be greater.

EEG believes that some of the proposed changes in the design are substantive and that not all the results of evaluating and testing Unit-0 of the TRUPACT-I design can be transferred to the new design. Questions that arise include:

1. Do the significant changes in dimensions of the TRUPACT really result in a package that is structurally stronger for all drop orientations as DOE claims?

2. How will the thinner inner liner and Kevlar puncture plates hold up under the full-scale drop and puncture tests imposed on Unit-0?
3. How will the decreased amount of dunnage (compared to the Unit-0 test where voids were carefully packed with considerable dunnage) affect integrity of the inner containers during drop and puncture tests?
4. Will the new method of applying insulation foam during construction avoid the problems of uneven density that occurred initially with the old method of application?

EEG believes that DOE must rigorously evaluate the effect of any proposed changes and should realize that full-scale tests may be necessary in order to prove the adequacy of the TRUPACT-II design.

## 6. CONCLUSIONS AND RECOMMENDATIONS

### 6.1 Conclusions

Although DOE stated in the WIPP Final Environmental Impact Statement (FEIS) that the transportation of wastes to the WIPP would comply with the regulations of the U.S. Department of Transportation and the corresponding regulations of the U.S. Nuclear Regulatory Commission, TRUPACT-I was designed in violation of NRC packaging regulations (10 CFR 71) on two specific counts:

1. Double containment was not provided as specified in 10 CFR Part 71.63 for solid material containing more than 20 Ci of plutonium;
2. The package was designed to provide continuous venting (through HEPA filters) from the storage cavity to the environment which is prohibited in 10 CFR Part 71.43(h) as well as in 49 CFR 173.413. A principal part of the venting issue is the problem of hydrogen gas generation in TRU wastes.

An additional issue is the DOE intent to allow shipment of up to 12,020 Ci of CH-TRU Waste in a TRUPACT.

#### 6.1.1 Double Containment

EEG estimates that the lack of double containment will increase the external radiation dose to the public and occupational workers by about 30% during normal transportation. Although the decreased population dose resulting from double containment was not large (about 90 person-rem during the project lifetime) it

is an incidental benefit that would accrue from meeting the regulation.

The principal advantage to double containment is in drastically reducing the latent cancer fatalities (LCF) that would occur if a Severity Category VII or VIII accident were to occur. For example, an average Savannah River Plant (SRP) shipment involved in a Category VIII accident would result in about 20 LCF with the current design and only about 8 LCF with double containment. Also, with single containment the maximum individual dose from a Category VIII accident involving the maximum proposed load could lead to early acute health effects.

Another advantage in double containment is the drastic decrease (from 12 to 0.02) in the expected number of radionuclide release accidents. All release accidents incur significant monitoring costs and the larger releases can cost millions of dollars for decontamination and waste disposal. Also, any release accident will cause an increase in public perception of transportation accident risks, even if there are no significant public doses received.

#### 6.1.2 Continuous Venting and Gas Generation

Continuous venting was incorporated into the TRUPACT design in 19 for the expressed purpose of eliminating possible package fatigue failure due to cyclical pressure changes. However, continuous venting compromises the integrity of a CH-TRU package because it provides a pathway for release of radionuclides to the environment in event of filter malfunction. In addition, the package may be more susceptible to failure around the vents if a severe transportation accident occurs.

Most of the CH-TRU wastes destined for WIPP produce some gas through radiolysis and processing the waste into a concrete matrix does not eliminate hydrogen generation. Therefore, some gas producing wastes will be shipped to WIPP.

There are uncertainties in predicting gas generation rates in individual Type A packages and in determining how the rates decrease with time after purging. However, experimental data produced to date indicate that venting alone will maintain hydrogen concentration below 4% in only very-low-curie content packages. Modeling results also suggest that a vented TRUPACT would not reach a 4% hydrogen concentration with such low curie packages within a reasonable shipping time. However, modeling data also suggest that a substantial number of the existing waste packages could not maintain hydrogen concentrations below 4% and it is questionable if the TRUPACT with high-curie loads could be transported in 30 days without exceeding this level.

Alternate strategies for controlling gas concentrations exist. It appears that a combination of administrative controls and use of hydrogen-oxygen recombiners or hydrogen getters in the waste package is probably a more reliable system for hydrogen control than venting.

### 6.1.3 High-Curie Shipments

The proposed TRUPACT maximum load of 12,020 Ci of americium-enhanced wastes and 11,200 Ci of heat source waste contains 357 times the plutonium-equivalent curies used in determining the "bounding" transportation accident consequences in the WIPP FEIS. This leads to estimated releases of 40 (Category VII accident) to 200 (Category VIII accident) times those projected in the FEIS.

A TRUPACT shipment with the maximum heat source load could contain about 3.7 times the inhalation toxicity of a spent fuel assembly being transported by truck. A Category VII accident is estimated to release 230 times the PE-Ci of a credible worst case spent fuel accident. A double contained TRUPACT would release only about one-fifth as much.

The proposed maximum loads are not necessary to ship CH-TRU wastes to WIPP. By proper load management it would be possible to ship all Savannah River Plant wastes with a maximum load of about 2,000 PE-Ci. Maximum loads at other facilities could be much less.

## 6.2 Recommendations

1. The present TRUPACT-I design should not be certified for transporting CH-TRU wastes to WIPP.
2. The TRUPACT-I design, without continuous venting, should be certifiable for transporting up to 20 Ci of plutonium per shipment. This limit would give a PE-Ci release in a Severity Category VII accident similar to that from a spent fuel shipment.
3. The TRUPACT should be redesigned to include double containment and eliminate continuous venting. Our understanding is that the current DOE proposal for the TRUPACT-II design incorporates these recommendations.
4. DOE should continue research to better define the gas generation problem and investigate the application of available technology for hydrogen gas control by hydrogen-oxygen recombiners and by hydrogen getters. A more

positive administrative control system should also be developed.

5. The maximum permitted load in a doubly contained TRUPACT should be set at about 2,000 PE-Ci. This limit would allow, by load management, the shipment of all stored wastes at all of the storage sites in 36 drum (or more) shipments and would reduce the estimated release in a Category VII accident to about 25 times that expected from a credible worse case spent fuel accident.
6. DOE should amend their 9/9/83 Order 5480.3 and require the shipment of plutonium bearing waste to meet the NRC 10 CFR 71 requirements of double containment.

## References

1. U.S. Department of Energy. "Final Environmental Impact Statement Waste Isolation Pilot Plant." DOE/EIS 0026. UC-70 October 1980 Vol I and II.
2. Tappen, J., Fredrickson, C., and Daer, G., "Preliminary Radiological Analysis of the Transportation of Contact Handled Transuranic Waste Within the State of New Mexico." WTSD-TME-002, Revision 1, June 1983.
- 2a. Cohen, S., "A Note on the Implications of DOE Exceptions to 10 CFR Part 71 in the Design of the TRUPACT-I Shipping Container," report to EEG by SC&A, Inc., April 1985.
3. IAEA Safety Standards, Safety Series No. 6, "Regulations for the Safe Transport of Radioactive Materials," 1985.
4. 49 CFR Part 171, "Requirements for Transportation of Radioactive Materials," Code of Federal Regulations Title 49.
5. Eakes, R.G., et al., "TRU Waste Transportation Package Development," SAND 80-0793, TTC-0085.
6. 10 CFR Part 71 Federal Register Vol 39, No 117, June 17, 1974, Title 10, Part 71.
7. 10 CFR Part 71, "Rule to Achieve Compatibility with the Transport Regulations of the International Atomic Energy Agency (IAEA)," Code of Federal Regulations, Federal Register Vol. 48, No. 152, August 1983.
8. December 17, 1979 letter from Ruth Clausen, Assistant Secretary for Environment, US DOE to Lee V. Gossick, Executive Director for Operations, US NRC.
9. December 18, 1979 letter from R. B. Pope, Sandia Laboratories, to Secretary of the Commission, US NRC.
10. U.S. Department of Energy Order 5480.1 Change 3, May 19.
11. "Andersen, J.A., et al., "Peer Review of the Preliminary Design and Program Interface for the Transuranic Waste Package Transporter (TRUPACT)," SAND-2405 June 1982, Specified External Distribution Only.

12. Pope, H.B., et al.. "Design Team Response to Peer Review of the Preliminary Design for the Transuranic Package Transporter," SAND 82-149. Specified External Distribution Only.
13. July 29, 1985 letter Robert H. Neill, EEG to Joseph McGough, DOE.
14. Neill, R.H. and Channell, J.K.. "Potential Problems from Shipment of High-Curie Content Contact-Handled Transuranic Waste to WIPP," EEG-24, August 1983.
15. U.S. Department of Energy Draft Order 5480.1A Change 3. July 29, 1983.
16. U.S. Atomic Energy Commission 4/18/84 Enclosure A. Title 10, Part 71, Chapter 1.
17. National Academy of Science, National Research Council. "The Effects on Populations of Exposure to Low Levels of Ionizing Radiation: 1980." July 1980.
18. EGG, Idaho, Inc. "INEL TRU Waste Presentation to the Environmental Evaluation Group from the State of New Mexico." November 1983.
19. Harvill, J.P.. "Preliminary Radiation Dose Assessment to WIPP Waste Handling Personnel," WTSD-TME-009, February 1985.
20. U.S. Department of Energy, Waste Isolation Pilot Plant Safety Analysis Report.
21. U.S. Nuclear Regulatory Commission "Final Environmental Impact Statement on the Transportation of Radioactive Material by Air and Other Modes," Office of Standards Development, NUREG-0170, Vol. I, December 1977.
22. Madsen, M., Wilmot, E., and Taylor, V., "RADTRAN II User Guide," Sandia National Laboratory, SAND 82-26, February 1983.
23. Woolfolk, S.W.. "Preliminary WIPP Transportation Analyses," WTSD-TME-002, April 1983.
24. Sandoval, R.P., Apple, M.A. and Grandjean, N.R., "The Fraction of Waste Contents Released from 55-Gallon Drums to the TRUPACT-I Cavity During Type B Package Testing." SAND 84-2645 (TTC-0537), May 1985.

25. Clements, T.L. and Kudera, D.E., "TRU Waste Sampling Program: Volume I - Waste Characterization," An Informal Report, EGG-WM-6503, September 1985.
26. U.S. Department of Energy, "Spent Fuel and Radioactive Waste Inventories, Projections and Characteristics," DOE/RW-0006 Revision 1, December 1985.
27. Finley, N.C., et al., "Transportation of Radionuclides in Urban Environs: Draft Environmental Assessment," NUREG/CR-0743 (SAND 79-0369), July 1980.
28. Wilmot, E.L., et al., "A Preliminary Analysis of the Costs and Risk of Transporting Nuclear Wastes to Potential Candidate Commercial Repository Sites" SAND 83-0667, June 1983.
29. Shefelbine, Henry C., "Preliminary Evaluation of the Characteristics of Defense Transuranic Wastes," SAND 78-1850, November 1978.
30. U.S. Department of Energy, "Draft Environmental Assessment Davis Canyon Site, Utah," DOE/RW-0010, December 1984.
31. Burgoyne, R.M. et al., "TRUPACT Draft Safety Analysis Report for Packaging (SARP)," SAND 83-7077/GA-A16860, November, 1984.
32. Molecke, Martin A., "Gas Generation from Transuranic Waste Degradation: Data Summary and Interpretation," SAND 79-1245, December 1979.
33. Clements, T.L. and Kudera, D.E., "TRU Waste Sampling Program: Volume II - Gas Generation Studies," EGG-WM-6503, September 1985.
34. Zerwekh, Al, "Gas Generation from Radiolytic Attack of TRU Contaminated Hydrogeneous Waste," LA-7674-MS, June 1979.
35. Kosiewicz, Stanley T., et al., "Studies of Transuranic Waste Storage Under Conditions Expected in the Waste Isolation Pilot Plant (WIPP), LA-7931-PR Progress Report, January 1980.
36. Science Applications International Corporation, "A Theoretical Model for Hydrogen Buildup and Dissipation," Draft Report, November 1985.

37. Henrie, James O., et al., "Hydrogen Control in the Handling, Shipping and Storage of Wet Radioactive Waste." RHO-WM-EV-9-P.
38. Kazanjian, A.R., "Gas Generation Results and Venting Study for Transuranic Waste Drums," RFP-3739.
39. Kazanjian, A.R., "Radiolytic Gas Generation in Plutonium Contaminated Waste Materials," RFP-2469, October 1976.
40. U.S. Nuclear Regulatory Commission, "Clarification of Conditions for Waste Shipments Subject to Hydrogen Gas Generation," IE Information Notice No. 84-72, September 1984.
41. U.S. Nuclear Regulatory Commission, Transportation Certification Branch Approval Record, Combustible Gas Mixture, May 22, 1985.
42. Trujillo, R.E. and Courtney, R.L., "Organic Hydrogen Getters," Journal of Materials Science, 12(1977)937-943.
43. Baxter, Richard G., "Description of Defense Waste Processing Facility Reference Waste Form and Canister," Savannah River Plant, DP-1606 Revision 1, August 1983.
44. Wilmot, Edwin L., "Transportation Accident Scenarios for Commercial Spent Fuel," SAND 80-2124, February 19.
45. U.S. Department of Energy, "Draft Environmental Impact Statement - Waste Isolation Pilot Plant," DOE/EIS-0026-D, April 1979.
46. U.S. Department of Energy, "Assessment of Transuranic Activity Limits for WIPP TRU Waste," WTSD-TME-062, April 1985.
47. Halverson, T.W. and Cole, L.T., "Optimization of Waste Operations at WIPP," Waste Management '86, Tucson, AZ, March 1986.
48. Ziegler, D.L. and Wilkinson, F.D., "An Assessment of Radiolytic Gas Generation in Waste Containers For Transportation Considerations," RFP-3735, September 1984.

APPENDICES

APPENDIX A

Modeling Hydrogen Generation and  
Dissipation in TRU Waste Packages

## APPENDIX A

### Modeling Hydrogen Generation and Dissipation in TRU Waste Packages

Hydrogen generation by radiolysis in the waste matrix of TRU waste packages can lead to the formation of potentially flammable concentrations in the void spaces unless properly controlled. At the present time there appears to be an inadequate experimental data base covering a wide range of waste categories, curie loadings, and varieties of waste packages on which to build programmatic and regulatory planning. Under these circumstances it is necessary to rely on modeling the behavior of hydrogen in enclosed volumes to extend the present experimental data base to include other possible combinations of wastes form, curie loading, hydrogen getters, package design, etc.

The EEG modeling effort is based on a generalized model of TRU waste container hydrogen production and removal developed by SAIC for DOE (Ref 36). The SAIC model was modified to accept input of specific vent characteristics (effective vent hole radius and filter thickness) and flow through the vent was presumed to be diffusion dominated. The geometry of the containers was restricted to two volumes for simplicity. The general mathematical formulation of the model follows the SAIC strategy except for the venting aspect and the specific representation of a decaying G (gas) due to matrix effects.

For an exhaustive discussion of the mathematical formulation of the model, reference should be made to the SAIC report (Ref 36).

Here, an abbreviated discussion will be given, with emphasis on aspects of the EEG model which are different from the SAIC version.

The EEG two-region model assumes an inner Type A waste container with a given void volume placed inside the TRUPACT, which has its own specific void volume dependent on the number of drums and dunnage volume used in loading (typically  $13.6\text{m}^3$ , but could be as little as  $4\text{m}^3$ ). For simplicity it is assumed that each drum releases hydrogen (if vented) into a proportionate share of the available TRUPACT void. The gases produced in the waste are assumed to quickly migrate to the accessible void of the waste container and then diffuse into the TRUPACT, and then to the outside if both are vented.

The rate of production of hydrogen and other gases is dependent on the alpha-curie loading of the waste and the  $G(\text{gas})$  and  $G(\text{hydrogen})$  values. Since a two-component model of hydrogen generation as a function of time was found to be indicated by our review of the data, our model has the form

$$H(t) = H_0 e^{-Kt} + H_1 \text{ (moles/hr)}$$

Where  $H_0$  is the production rate at time  $t = 0$  and  $K$  is the decay constant for gas generation. A similar expression describes the production of other gases such as  $\text{CO}_2$ .

Once released to the void volume, the hydrogen concentration is computed as a molar fraction of the total number of moles in the void.

$$C(t) = N(t)/M(t)$$

Where  $N(t)$  is the number of moles of hydrogen and  $M(t)$  is the total number of moles in the void at time  $t$ . The addition of one mole of hydrogen to a particular volume increases both  $N(t)$  and  $M(t)$  by one, but the addition of a molecule of another gas increases only  $M(t)$  by one. If the void is vented so that the inventory is constant, then the addition of a mole of any gas will result in a mole being released. The probability that the released mole is a mole of hydrogen is given by the relative concentration of hydrogen,  $C(t)$ . Clearly, this assumption is reasonable only if complete and instantaneous mixing always occurs (at least to the level of resolution of the smallest time step in the calculation, about one hour).

The flow of hydrogen out of a vented container is presumed to occur through a vent filter. Rather than assuming "plug" flow (i.e., a volumetric rate defined by a hole area and average velocity), it is assumed that the process is diffusion dominated at the pressures and flow rates anticipated. The hydrogen flux through a filter is represented by the relation:

$$DF(\text{moles/sec}) = (P/RT) \cdot D \cdot (FA/FX) \cdot (C_2 - C_1)$$

Where

$P$  = Pressure in container

$R$  = Ideal gas constant

$T$  = Temperature, deg K.

$FA$  = Filter area

$FX$  = Filter equivalent thickness

$(C_2 - C_1)$  = Hydrogen concentration differences

$D$  = Diffusion coefficient for hydrogen in air

The equivalent thickness is estimated following the approach of Ziegler (Ref 48), based on the characteristics of the vent

$$FX = FX2 + (FA2) * (FX1) * (F2) / (FA1) * (F1)$$

Where

FX1 = Hole thickness

FA1 = Hole area

F1 = Hole porosity

FX2 = Filter thickness

FA2 = Filter area

F2 = Filter porosity

In the case of sealed containers, the pressure is calculated at each time step in the calculation by averaging changes in temperature and total gas inventory, and converted into estimated changes in concentration using the ideal gas law.

In general, the time rate of change in hydrogen in the  $i^{\text{th}}$  container is given by

$$\frac{dN_i}{dt} = H_i(t) - R_i(t) + [V_{i-1}(t) - V_i(t)] + Q_i(t)$$

Where

$H_i(t)$  = Hydrogen generation rate

$R_i(t)$  = Hydrogen removal rate  
by absorbers (if present)

$V_i(t)$  = Hydrogen flux due to  
diffusion through vents

$Q_i(t)$  = Hydrogen flux due to temperature and  
pressure changes

APPENDIX B

Discussion of Propargyl Ethers as Hydrogen  
Getters with Respect to Nuclear Waste Disposal

DISCUSSION  
OF  
PROPARGYL ETHERS  
AS  
HYDROGEN GETTERS  
WITH RESPECT TO  
NUCLEAR WASTE DISPOSAL

by

M.P. Neary, PhD

June 30, 1986

Experience to date with the model indicates that by using actual filter characteristics for the Rocky Flats Plant small bung filter and the reported percent void, hydrogen fraction and curie loading for a set of experimental drums, it is possible to approximately match the reported hydrogen concentration changes with time in both vented and unvented cases. The "free" variable in this approach is G(gas). It was as a result of such a fitting-process that the two-component decaying G(gas) concept emerged. An alternative approach based on a fixed G (gas) concept and another time varying parameter may possibly also be found to explain the observed data. But the present approach offers the considerable advantages of having successfully predicted independent observed time-varying G(gas) and requiring a minimum of ad-hoc parameter value choices in the initialization of the model.

A BASIC language version of the model used in these simulations will be available to interested parties.

## INTRODUCTION

Considerable concern by the New Mexico Environmental Evaluation Group is centered on radiolytically produced hydrogen in the TRUPACT shipping containers which are scheduled to be used to transport transuranic waste to WIPP.<sup>(1)</sup> It is not only possible but probable that radiolytic or catalytic hydrogen will be produced by combination of certain transuranic waste and other organic chemicals abundant with hydrogen. This would be a problem if solutions, aqueous or organic, of alpha-emitting actinides were allowed in WIPP storage containers. According to one source,<sup>(2)</sup> a build-up of hydrogen gas to 4% by volume or more in the containment system constitutes an explosive hazard. NRC has done work to confirm the older lower explosive limit shown above. Their findings show that 10 to 12% by volume hydrogen in air is a more practical lower limit for explosion.<sup>(3)</sup> Given either limit it is certainly true that a violent explosion can result from low concentrations of hydrogen in air. Explosions occurring in this way would probably cause little direct damage to humans; however, the accidental dispersal of transuranic wastes could cause considerable indirect losses.

Means of removing gaseous hydrogen from a mixture of gases exist and are sufficiently efficient when intelligently used to obviate concern for the generation of explosive levels of hydrogen within nuclear waste transportation and storage containers. Such means include: electrical recombiners, catalytic recombiners, and organic getters. Because the first two produce water their use would be forbidden. The subject to be considered here is organic getters and, in particular, the gettering properties of propargyl or acetylenic compounds. First, some background information on the explosive character of hydrogen will be considered.

## BACKGROUND

Of the diatomic gases, hydrogen is the smallest (occupies the least volume per mole), has the greatest mean free path (largest distance or longest time between collision) and the greatest velocity at STP.\*<sup>(5)</sup> The diffusion rate of hydrogen in air, which is related to the square root of the inverse ratio of the densities of hydrogen and air, is the greatest of all diatomic gases. Because of these physical properties, hydrogen is relatively fast to be uniformly distributed throughout a volume when driven by diffusion alone. Mixing processes driven by heat or agitation serve to hasten or maintain uniform distribution. Mixtures of hydrogen and a variety of other gases are flammable/explosive. They include oxygen, halogens, and nitric and nitrous oxides.<sup>(4)</sup>

The terms "flammability" and "explosive limits" are generally loose. Flammability may refer to the relative ability of the material to burn exothermally in the presence of oxygen. From this viewpoint, pure hydrocarbons are more flammable than hydrocarbons containing oxygen which, in turn, are more flammable than those containing halogen. Alternatively, flammability may refer to the volatility of a compound. Flammability may be influenced by explosive limits of mixtures of air and combustible gases. Thus, a mixture of n-pentane in air will explode only when the percent by volume of pentane is between 1.5 and 7.5. At higher or lower concentrations no explosion will take place on application of spark or flame, or ignition. At the other extreme, hydrogen is explosive in the range of 4 to 74 percent by volume in air!<sup>(2,6)</sup> Ignition is required for both combustion and explosion, hence ignition

---

\*Standard temperature and pressure

temperatures relate to the ease of initiation of either combustion or explosion. The ignition temperature of hydrogen within the explosive limits cited above is 530°C in air. (4) Hence, the activation energy for the formation of water from hydrogen and oxygen (the ignition of hydrogen in air) is fairly high, taking the ignition temperature as a measure of the activation energy. Active surfaces of certain metals may greatly lower the activation energy and hence the ignition temperature. (6)

Most workers agree that the difference between a conflagration and an explosion of gas-air mixtures is related to the burning velocity expressed in centimeters per second. The maximum burning velocity of hydrogen-air mixtures of between 4 and 74 percent by volume is 440 cm/sec, the greatest or nearly so of any combustible gas-air mixture by a factor of ten. By comparison, n-pentane, which forms a flammable/explosive mixture with air at 1.5 to 7.5 percent by volume, has a maximum burning velocity of 43 cm/sec! It can be concluded that hydrogen-air mixtures can explode with unusual violence.\* (6)

#### BACKGROUND SUMMARY

The minimum explosive limit of hydrogen is very low. The activation energy for hydrogen ignition can be drastically lowered by adsorption of hydrogen onto certain metal surfaces. Ignition of hydrogen-air mixtures within the explosive limits results in a particularly powerful, and therefore destructive, explosion. The radiolytic generation of hydrogen from nuclear

---

\*Most hydrogen research laboratories have either blowout walls or a roof that is not fastened.

waste within containers is expected in amounts that could reach explosive levels.

The use of a hydrogen getter that operates continuously for long periods of time, that does not form water or pyrophoric compounds, that is effective, efficient, generally inert and nontoxic, and that is small in size and inexpensive is highly desirable. (7)

### PROPARGYL HYDROGEN GETTERS

#### Gettering Mechanism

Generally, an unsaturated organic compound can take up (getter) hydrogen and its isotopes when an active metallic surface is present. Such metals are those found in Group VIII of periodic table. (8) If a dry mixture of the getter and active metal were suddenly introduced into a gaseous mixture of hydrogen and air, and the volume percent of hydrogen were within the explosive limits, ignition and explosion would occur without significant getting. This is due to the vast difference in the rate laws for getting and the competing explosive reaction. The explosion occurs because of the presence of active metal surfaces. However, if the hydrogen is slowly introduced into a mixture of getter, active metal, and air, the getter reaction will limit the buildup of hydrogen, thus keeping the overall volume percent of hydrogen below the lower explosive limit. The specific pathway by which getting proceeds is specified below.

Although hydrogenation (getting) is an exothermic process, the reaction does not take place spontaneously because the amount of energy required to break a pi bond in the olefin or propargyl compound, or a sigma bond in hydrogen, is too large. The function of the active metal (catalyst) is to lower this

activation energy stepwise so that the activation energy of each is much lower than that required for thermal breaking of the pi or sigma bonds. (6.8)

Metals such as platinum, palladium, silver, nickel, and copper strongly adsorb hydrogen and unsaturated molecules. The atoms in the metal surface have unpaired electrons which can interact with the electrons in the relatively exposed sigma orbital of the hydrogen molecule and the pi orbital of the double or triple bond. Hydrogen thus adsorbed can dissociate, yielding adsorbed hydrogen atoms. This is due to a great reduction of activation energy for sigma bond breaking of adsorbed hydrogen. The alkene or alkyne can form an adsorbed free bi-radical on such a surface. For the olefin, reaction of the free bi-radical and two hydrogen atoms leads to a saturated molecule and desorption. For the alkyne, four hydrogen atoms react before saturation and desorption. Because of the various steps in the reaction involving unpaired electrons and weak bonds, none has a high activation energy. (6.8)

In order that reaction occur between the adsorbed molecules, they must approach each other closely and be properly oriented. (9) Not only the size and structure of the reactants but also the crystal structure of the surface of the catalyst determines these space relationships. The reverse reaction is not possible in view of both energetic, entropy and stereo considerations. (6.11) It is evident that the optimum conditions and type of catalyst will vary for every different pair of reactants. Fortunately, hydrogenation catalysts have been developed which show high activity for a wide range of propargyl compounds: hence catalytic hydrogenation is an eminently practical process. (8)

## Hydrogenation Catalysts

A few of the most effective metal catalysts for hydrogenation of propargyl compounds are listed below:

### Heterogeneous Hydrogenation Catalysts (7.8,11)

Platinum black (unsupported)  
Platinum black/carbon  
Platinum black/calcium carbonate  
Platinum black/asbestos  
Platinum black/alumina  
Palladium black (unsupported)  
Palladium black/carbon  
Palladium black/calcium carbonate  
Palladium black/asbestos  
Palladium black/alumina

### Homogeneous Hydrogenation Catalysts (7.9,10)

Noble metal chelates  
Organometallic complexes (i.e., dichloro-bis  
(triphenyl-phosphine) platinum or palladium

For the supported catalysts listed above under "Heterogeneous Hydrogenation Catalysts", the term "black" refers to the most finely divided form of element. The elements' percent by weight supported on the various substrates ranges from 1% to 20%; however, 5% by weight gives the best results.<sup>(11)</sup> Even though other metals in Group VIII of the periodic table can be used as catalysts for hydrogenation, platinum and palladium are usually preferred because of the rapid hydrogenation reactions they catalyze. Other less expensive metals from Group VIII may provide sufficiently rapid catalysis. In any case, the catalyst-propargyl compound weight ratio is in practice adjusted

to provide both the desired capacity and a hydrogenation rate that exceeds the production by a margin of safety. For example, a propargyl ether-catalyst formulation between 60 and 65% by weight of organic gives 90% hydrogenation in 60 minutes at a rate of 14.4 mm H<sub>2</sub> per mole of organic getter per sec. The catalyst used was 5% by weight supported on calcium carbonate. (7.9) The homogeneous catalysts listed above require hydrogenation reactions to be carried out in solution. The best advantage of such an approach would be realized only when the hydrogen bearing gas mixture is passed or bubbled through the solution. (11) This means of limiting hydrogen in a closed volume will not be discussed further here.

### Propargyl Organic Compounds

Numerous off-the-shelf propargyl compounds are available. They range in physical state from gas to liquid to solid. And as their molecular weight increases the compounds tend to solids and to act less pyrophorically in a hydrogen and oxygen atmosphere. Likewise, flammability, toxicity, and other irritating properties diminish as molecular weight increases. The overall toxicity of propargyl compounds generally depends more on substituent groups than on the acetylenic character. In general propargyl compounds are unreactive alone unless in the presence of a catalyst. Solid propargyl compounds generally are more versatile in the subject application. (11.12)

The reactivity of propargyl compounds is divided into two categories, one concerned with the acetylenic character and the other concerned with the substituent groups. (12) A third

---

\*Substituent groups are those chemical moieties introduced on the starting materials or later to either make the synthesis easier or impart specific physical properties to the product.

category could be considered in which the effect of substituent groups on the acetylene group is considered. For purposes under discussion, the last two categories are the most important because a wide range of substituted propargyl compounds are available. Thus, side reactions involving substituent groups and the environment can be avoided by selection of the appropriate propargyl compound. Substituent groups near (i.e., within a carbon atom) the propargyl group usually reduces its capacity for and rate of hydrogenation.<sup>(7,9)</sup> This is not surprising in view of the adsorption and bi-radical formation step described above. The propargyl group does not react with fixed gases such as oxygen, nitrogen, carbon monoxide, carbon dioxide, and methane except under extremes of temperature and pressure (i.e., greater than 150°C and 2 Atmospheres). Therefore, these gases do not compete or interfere with hydrogen uptake in a mixture.<sup>(11)</sup> Likewise, a moist, acidic, or corrosive atmosphere will not react with a propargyl compound such as diphenyl propargyl ether (DPPE), particularly if the DPPE-catalyst solid mixture is not immersed in such a liquid. At elevated temperatures (ca 120°C) many propargyl compounds will crosslink.<sup>(9)</sup>

The three selection rules for the appropriate propargyl compound are: low or no substituent reactivity, a solid over the temperature range of use, and the lowest molecular weight with the greatest molar capacity for hydrogen uptake. The propargyl compound that has been most useful is the dimer of 1,6-diphenoxy-2,4-hexadiyne or diphenyl propargyl ether, DPPE. DPPE is a solid up to 80°C, and when combined with a hydrogenation catalyst, may be used with equal efficiency to get hydrogen at a hydrogen partial pressure as low as  $10^{-6}$  atmospheres and up to 2 atmospheres. Whether or not DPPE may be used at low temperatures depends on the rate of hydrogen generation (i.e.,

if the rate is low, DPPE can be used to  $-50^{\circ}\text{C}$ ).<sup>(9)</sup> Even though DPPE melts at about  $80^{\circ}\text{C}$  and cross linkage may be initiated at about  $120^{\circ}\text{C}$ , hydrogenation still occurs. At  $150^{\circ}\text{C}$  further hydrogenation is limited by complete cross linking. The maximum efficiency for hydrogenation is obtained between  $-4^{\circ}\text{C}$  and  $71^{\circ}\text{C}$ . (7.9.10.11)

Because DPPE is a solid below  $80^{\circ}\text{C}$ , it has virtually no vapor pressure below that temperature and no flammability. When exposed to direct flame, however, the compound will burn. It is estimated that DPPE mixed with the hydrogenation catalyst will be effective for 10 years at  $50^{\circ}\text{C}$  and lose less than 10% of the propargyl compound due to vaporization or side reactions with impurities.<sup>(9)</sup>

#### Formulation

The DPPE and catalyst are usually combined in a suitable solvent so that DPPE is dissolved. The resulting slurry can be dried in a vacuum oven, painted onto a surface and dried or adsorbed onto another substrate, as desired. The DPPE coating on the catalyst thus forms a barrier which reduces or obviates the hydrogen-oxygen reaction at the catalyst surface. Because hydrogen easily diffuses through the coating and oxygen does not, very little or no water is thus formed.<sup>(7.11)</sup>

The surface area of the coated catalyst affects the initial rate of hydrogenation and has little to do with the total capacity. In fact, for DPPE, 65% by weight on catalyst (5% palladium black on calcium carbonate) hydrogenates to 100%.<sup>(7.9)</sup> The uptake rate of this formulation is  $14.4 \text{ mm H}_2/\text{mole of DPPE/sec}$ .<sup>(9)</sup> Hence, if the hydrogen partial pressure is increasing at  $14 \text{ mm/hour}$ ,  $1/3600$  of a mole of DPPE-catalyst would hydrogenate

at a rate equal to the production rate. Given the production rates of hydrogen, simple calculations predict the quantities of DPPE-catalyst needed, bearing in mind that the uptake is 100% efficient and 4 moles of hydrogen are taken up per mole of DPPE (MW=262 and molar volume =  $183 \text{ cm}^3$ ).

#### Cost

The off-the-shelf prices of catalyst and DPPE are generally not high (i.e., DPPE costs approximately \$1.00/gram and palladium black on activated carbon (5% by weight) costs approximately \$1.50/gram).

However, it is expected that economy of scale will reduce both costs substantially. In the case of DPPE, a low price of \$0.25/gram could be anticipated along with \$0.75/gram for palladium black on activated carbon (5% by weight). Other less expensive metals which catalyze gettering, albeit at a lower rate, may still be appropriate (silver, for example). (11,13)

#### Use

Once fabricated, the DPPE-catalyst solid mixture can be disposed in a variety of ways. Coatings on surfaces in the container and/or loose placement in a dry container is acceptable. (11) The mixture can be disposed between two porous plugs or filters and fixed in the top of the storage drums or the TRUPACT vent. Because vented containers are expected to "breathe", by locating the getter near or in the vent, effective gettering is expected. Whether or not the getter should be disposed at various locations in the TRUPACT cavity depends on the nature of the load of storage drums and how they are vented and if a getter is disposed within them. Clearly, if each drum that is likely to

produce hydrogen is equipped with a getter, no further gettering should be required in the TRUPACT. However, if the barrels are vented into the TRUPACT and are not equipped with getters, the TRUPACT can and should be so equipped with an appropriately scaled getter system.

#### Summary

Propargyl getters are effective in maintaining a very low (less than 1 ppm) hydrogen concentration in a closed space. Their use requires no power, generates no water, occupies a very small volume, and last 10 years at 50°C. Their cost is modest, they are no-toxic and non-pyrophoric. The above characteristics recommend propargyl getters in most circumstances.

## BIBLIOGRAPHY

- 1) Neill, R.H. and J.K. Channell, "Potential Problems from Shipment of High-Curie Content Contact-Handled Transuranic (CH-TRU) Waste to WIPP" Report EEG-24, Environmental Evaluation Group, Environmental Improvement Division, Health & Environment Department, State of New Mexico, August 1983.
- 2) Hodgman, C.D., Editor-In-Chief, Handbook of Chemistry and Physics 42nd Edition The Chemical Rubber Publishing Co. (1960)
- 3) Neill, R.H., private communication
- 4) Dean, John A., editor. Lange's Handbook of Chemistry 12th edition, McGraw-Hill Book Company, 1979.
- 5) The Merck Index, 9th edition, Merck & Co., Inc., Rahway, N.J., USA, 1976.
- 6) Noller, Carl. Chemistry of Organic Compounds, W. B. Saunders Co., Philadelphia, 1957.
- 7) Anderson, D.R., et al. U.S. Patent #3,896,042 (1975).
- 8) Pearce, R., et al. Catalysis and Chemical Processes, Halsted Press, John Wiley and Sons, New York, 1981.
- 9) Trujillo, R.E., et al J. Mater. Sci., 12(1977)937.
- 10) Courtney, R.L., et al J. Mater. Sci., 12(1977)175.
- 11) Neary, M.P., Los Alamos National Laboratories Classified Data, 1980-81.
- 12) Streitwieser, Andrew, Jr. and Clayton H. Heathcock, Introduction to Organic Chemistry, Macmillan Publishing Co., Inc. New York, 1981.
- 13) Chemical Dynamics Corp. So Plainfield, NJ 07080

Environmental Evaluation Groups  
Reports

(Continued)

- EEG-11 Channell, James K., Calculated Radiation Doses From Radionuclides Brought to the Surface if Future Drilling Intercepts the WIPP Repository and Pressurized Brine, January 1982.
- EEG-12 Little, Marshall S., Potential Release Scenario and Radiological Consequence Evaluation of Mineral Resources at WIPP, May 1982.
- EEG-13 Spiegler, Peter, Analysis of the Potential Formation of a Breccia Chimney beneath the WIPP Repository, May 1982.
- EEG-14 Zand, Siavosh M., Dissolution of Evaporites and Its Possible Impact on the Integrity of the Waste Isolation Pilot Plant (WIPP) Repository, (Draft).
- EEG-15 Bard, Stephen T., Estimated Radiation Doses Resulting if an Exploratory Borehole Penetrates a Pressurized Brine Reservoir Assumed to Exist Below the WIPP Repository Horizon, March 1982.
- EEG-16 Radionuclide Release, Transport and Consequence Modeling for WIPP. A Report of a Workshop Held on September 16-17, 19, February 1992.
- EEG-17 Spiegler, Peter, Hydrologic Analyses of Two Brine Encounters in the Vicinity of the Waste Isolation Pilot Plant (WIPP) Site, December 1982.
- EEG-18 Spiegler, Peter, Origin of the Brines Near WIPP from the Drill Holes ERDA-6 and WIPP-12 Based on Stable Isotope Concentrations of Hydrogen and Oxygen, March 1983.
- EEG-19 Channell, James K., Review Comments on Environmental Analysis Cost Reduction Proposals (WIPP/DOE-136) July 1982, November 1982.
- EEG-20 Baca, Thomas E., An Evaluation of the Non-radiological Environmental Problems Relating to the WIPP, February 1983.
- EEG-21 Faith, Stuart, et al., The Geochemistry of Two Pressurized Brines From the Castile Formation in the Vicinity of the Waste Isolation Pilot Plant (WIPP) Site, April 1983.

Environmental Evaluation Groups  
Reports

(Continued)

- EEG-22 EEG Review Comments on the Geotechnical Reports Provided by DOE to EEG Under the Stipulated Agreement Through March 1, 1983. April 1983.
- EEG-23 Neill, Robert H., et al., Evaluation of the Suitability of the WIPP Site. May 1983.
- EEG-24 Neill, Robert H. and James K. Channell, Potential Problems From Shipment of High-Curie Content Contact-Handled Transuranic (CH-TRU) Waste to WIPP. August 1983.
- EEG-25 Chaturvedi, Lokesh, Occurrence of Gases in the Salado Formation. March 1984.
- EEG-26 Spiegler, Peter, Environmental Evaluation Group's Environmental Monitoring Program for WIPP. October 1984.
- EEG-27 Rehfeldt, Kenneth, Sensitivity Analysis of Solute Transport in Fractures and Determination of Anisotropy Within the Culebra Dolomite. September 1984.
- EEG-28 Knowles, H. B., Radiation Shielding in the Hot Cell Facility at the Waste Isolation Pilot Plant: A Review. November 1984.
- EEG-29 Little, Marshall S., Evaluation of the Safety Analysis Report for the Waste Isolation Pilot Plant Project. May 1985.
- EEG-30 Dougherty, Frank, Tenera Corporation, Evaluation of the Waste Isolation Pilot Plant Classification of Systems, Structures, and Components. July 1985.
- EEG-31 Ramey, Dan, Chemistry of the Rustler Fluids. July 1985.
- EEG-32 Chaturvedi, Lokesh and James K. Channell, The Rustler Formation as a Transport Medium for Contaminated Groundwater. December, 1985.