

RH945046.CDR

Figure 1 PWR primary system nodalization for Westinghouse 4-loop design.

9809290316 980922
PDR ADDCK 05200003
PDR

Enclosure 1

DATE: 05/01/94
REVISION: 0.0

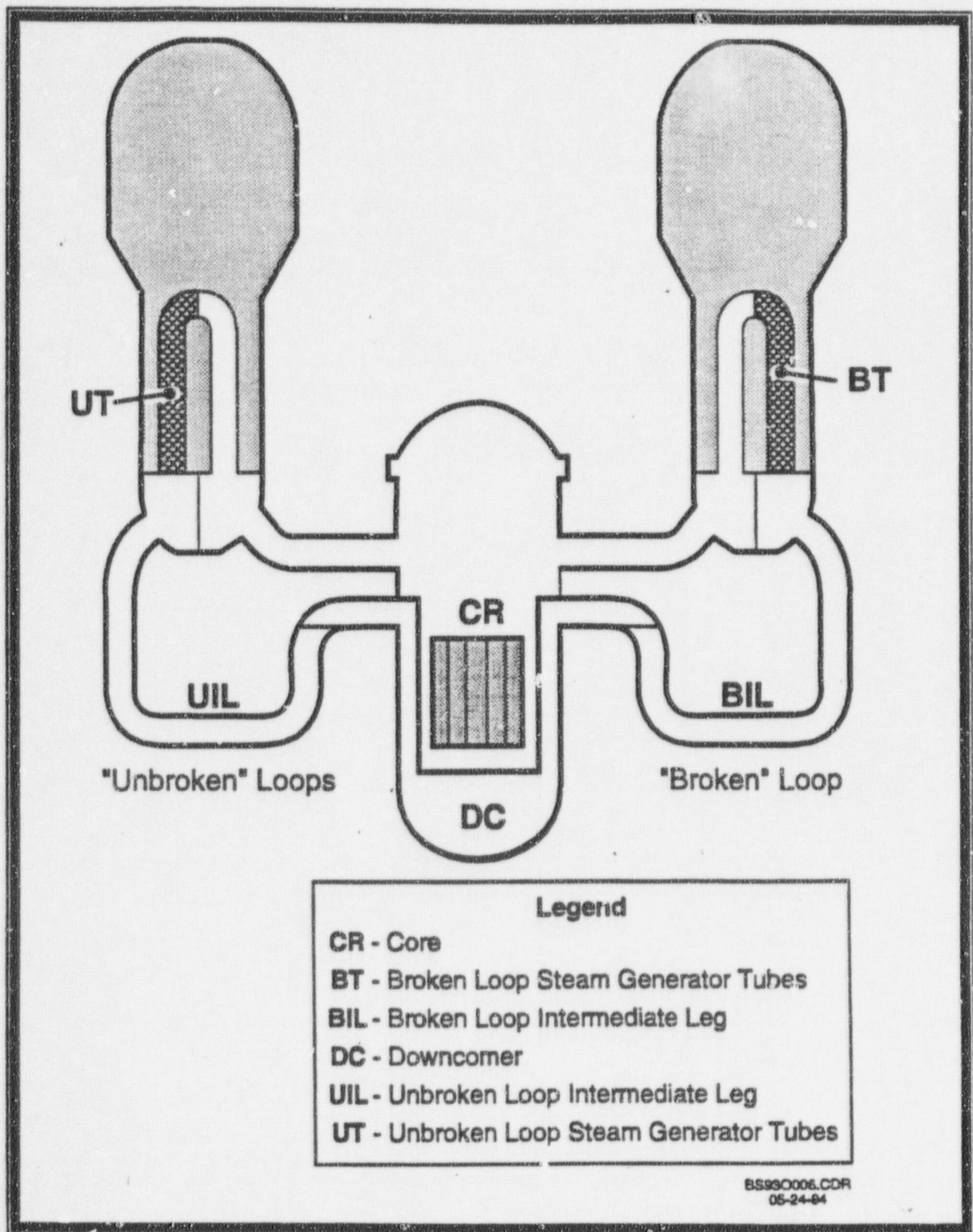

Figure 3 Primary system water pool nodes.

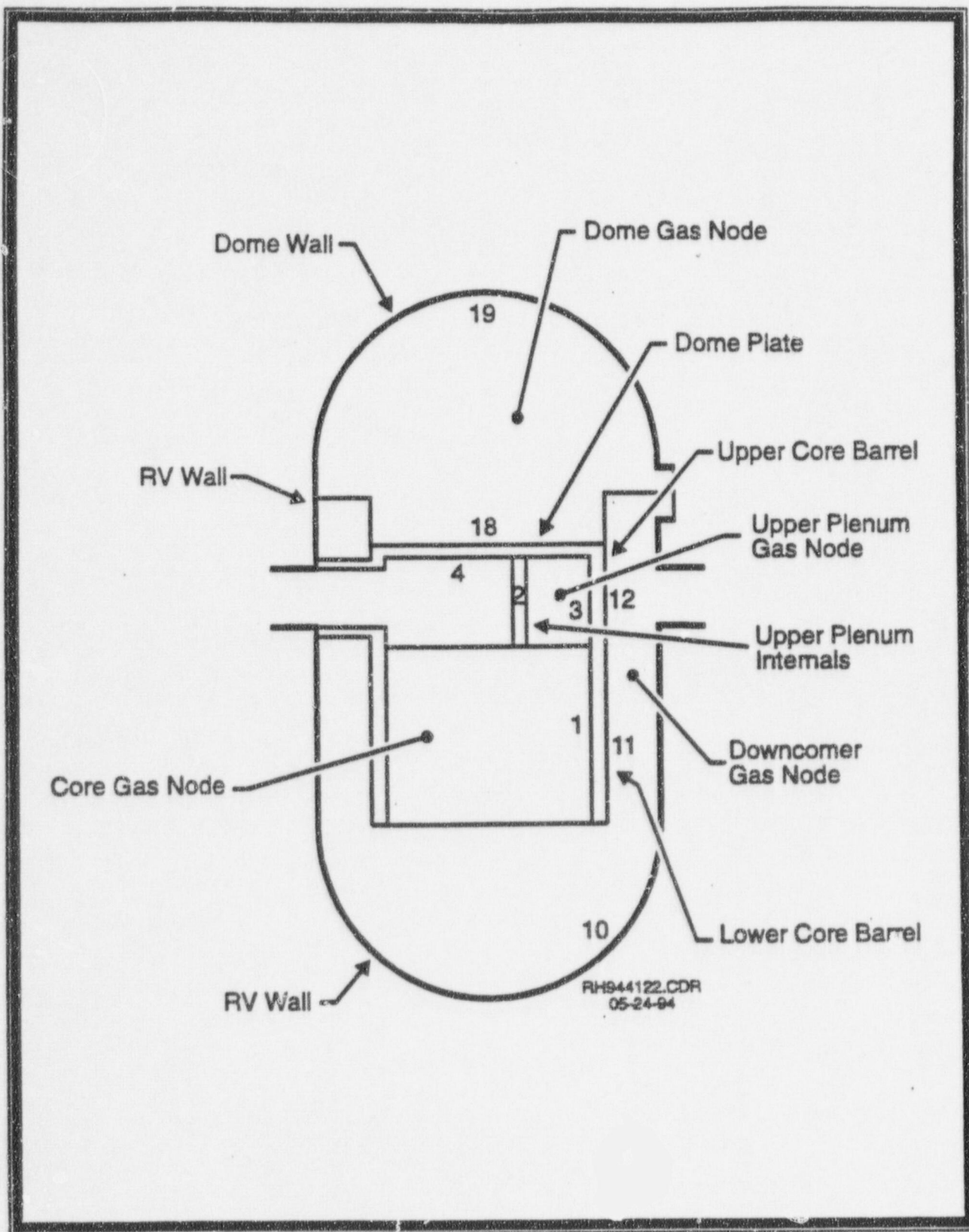

Figure 5 Heat sinks and control volumes in reactor vessel.

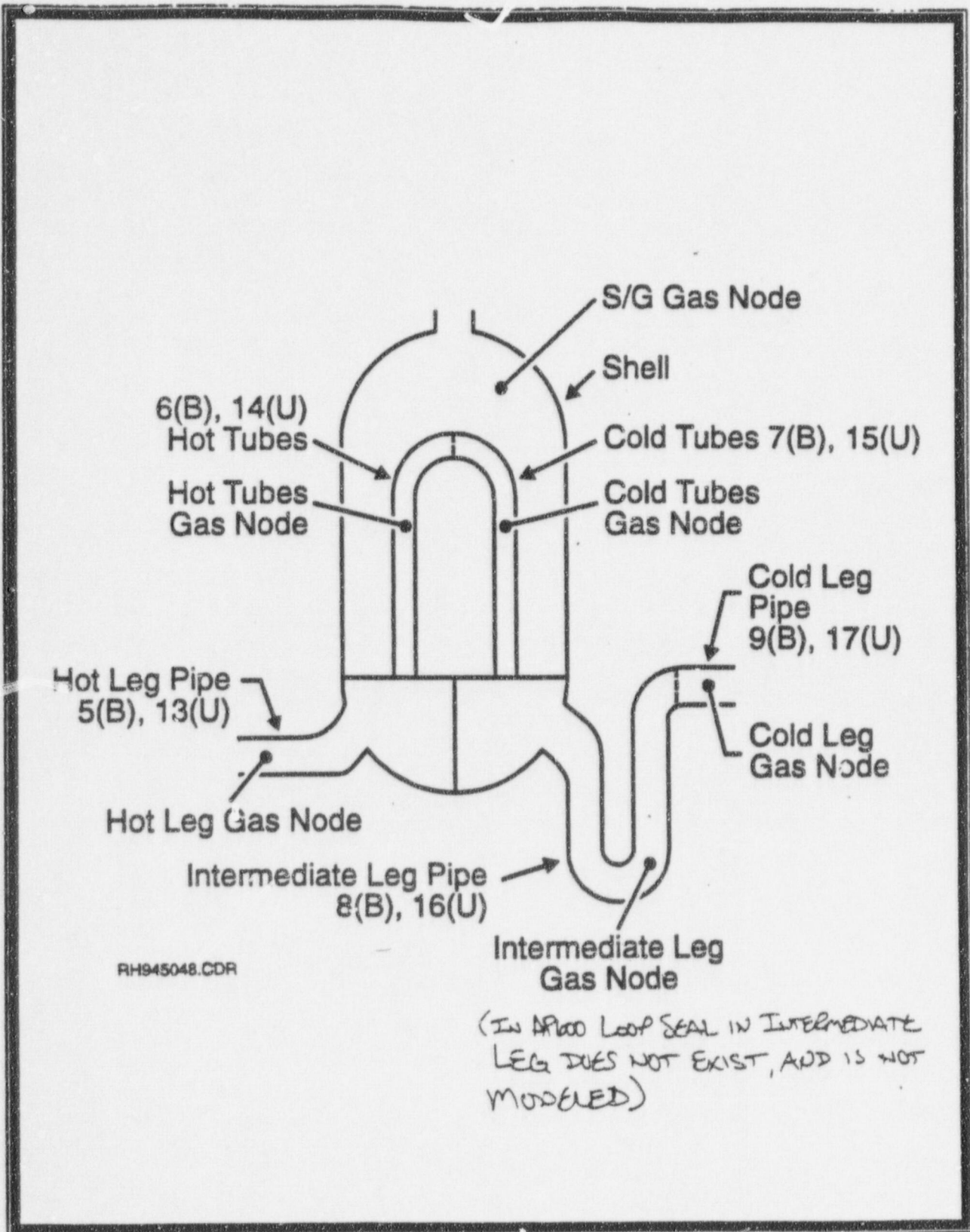

Figure 6 Heat sinks and control volumes in U-tube steam generator loop.

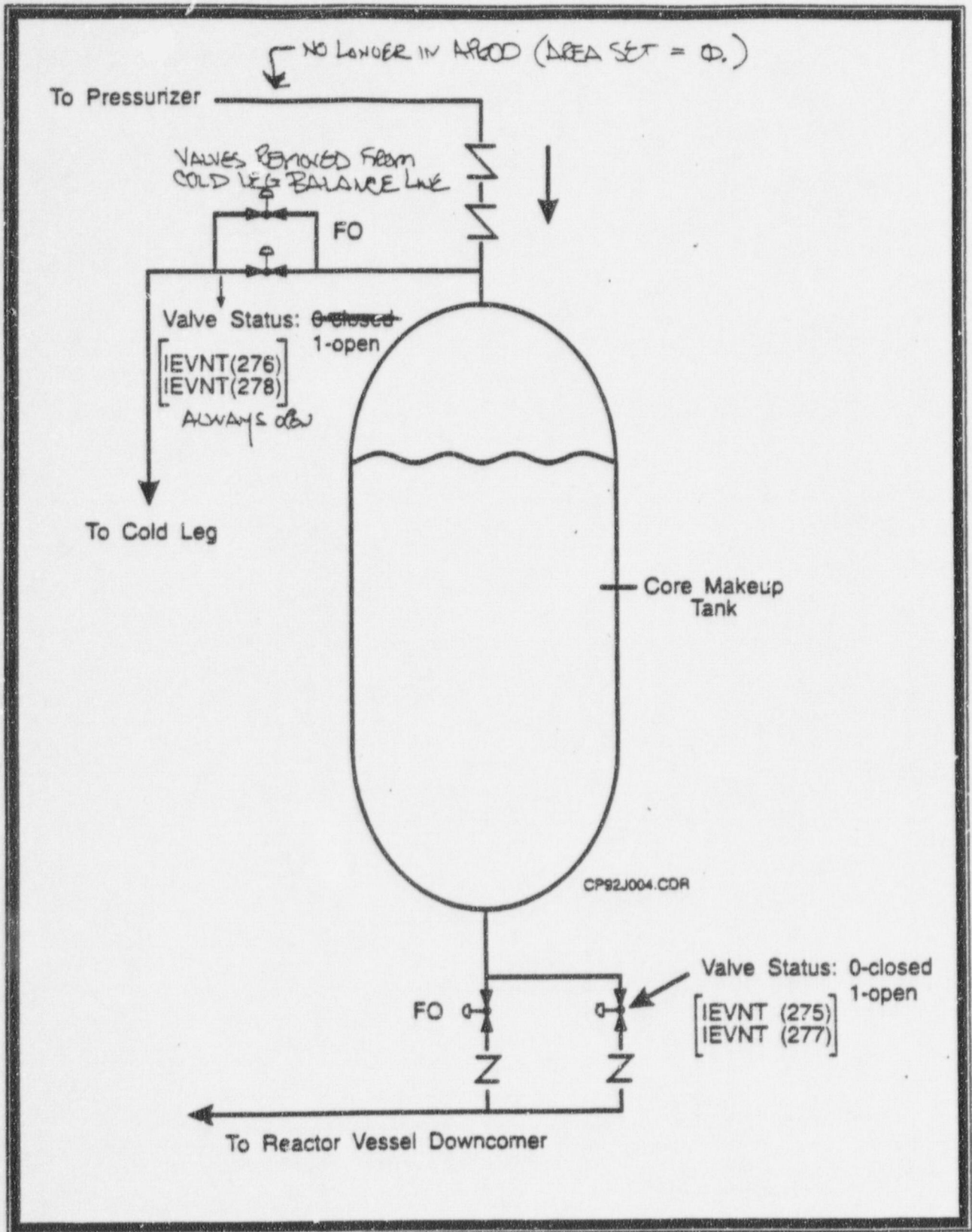

Figure 1 Core makeup tank in AP600 design.

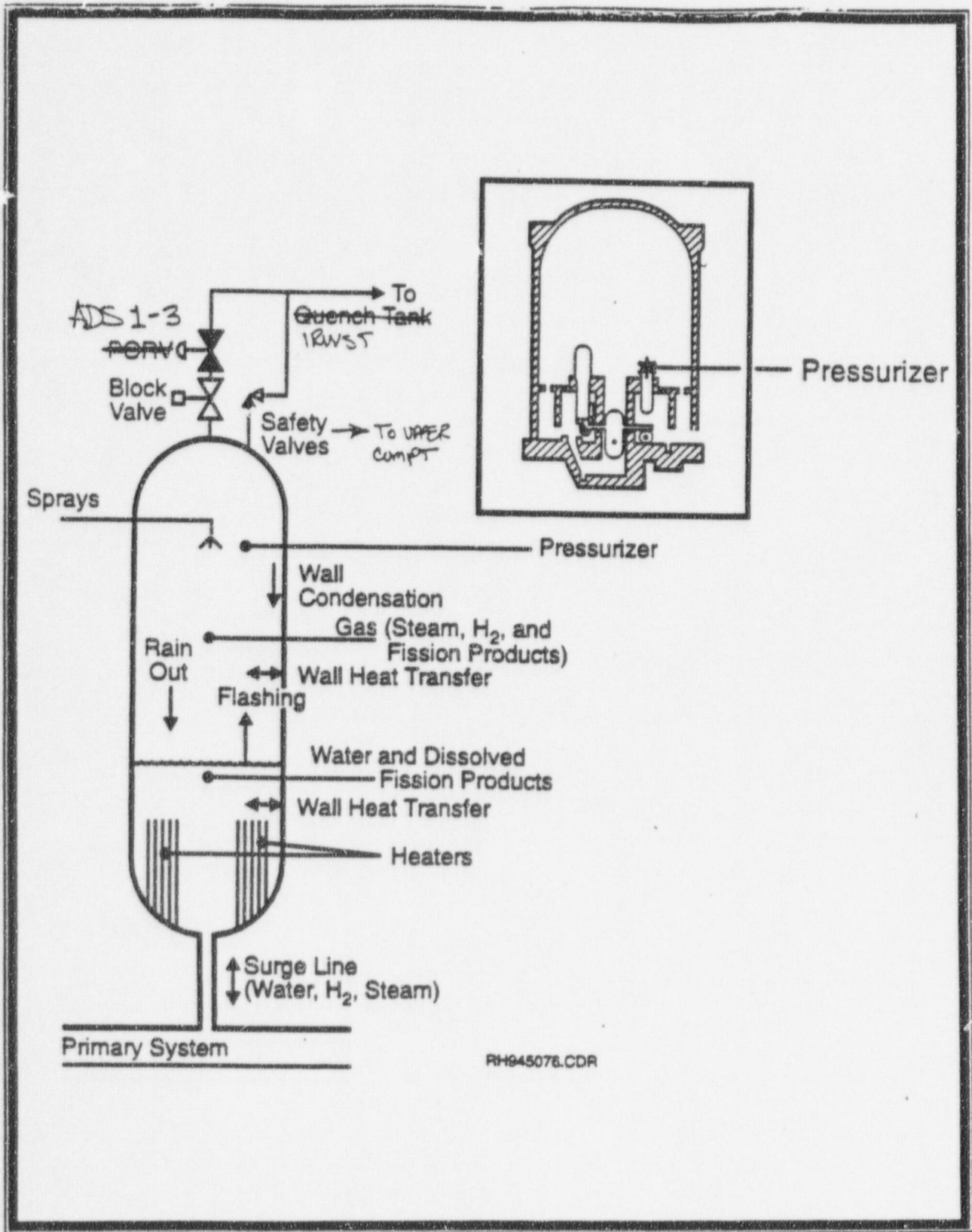
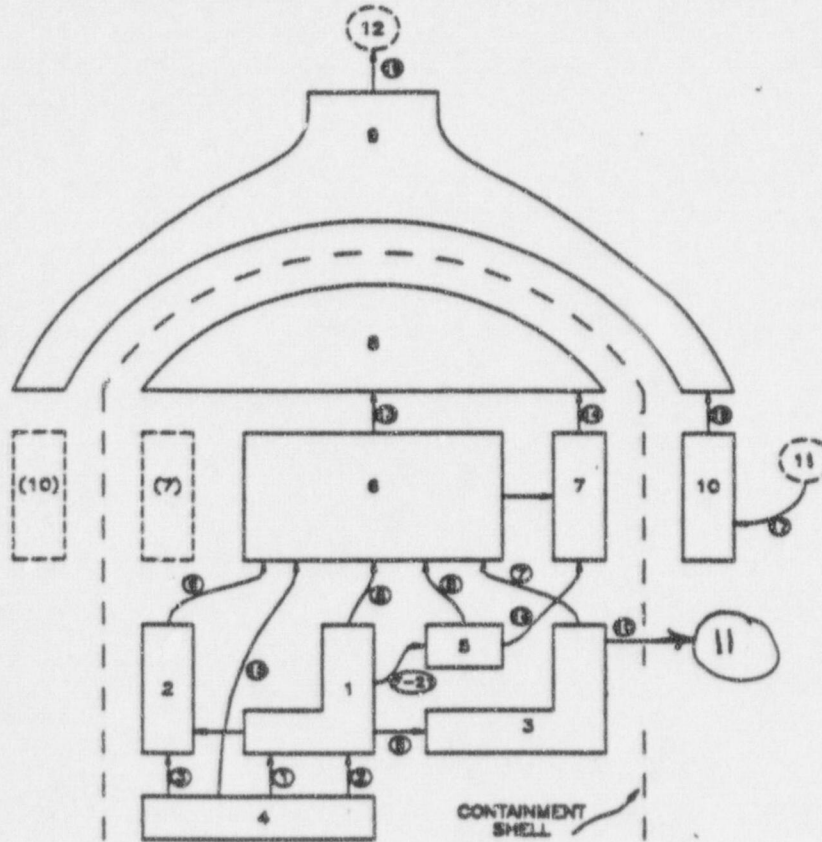

Figure 1 Schematic Description of the Pressurizer.

Containment Nodal Network (11-Node)



- Node 1 = SG Compt 1
- Node 2 = SG Compt 2
- Node 3 = Low Compt, CMT, Accum
+ Valve Rooms
- Node 4 = Reactor Cavity
- Node 5 = IRWST Room
- Node 6 = Upper Compt Inner Volume
+ Refueling Canal

- Node 7 = Upper Compt Outer Volume
- Node 8 = Upper Compt Dome
- Node 9 = PCCS Dome
- Node 10 = PCCS Annulus
- ~~Node 11 = Middle Annulus~~
- Node 11 = Environment

Figure K-1

AP600 MAAF 4.0 Parameter File

Case t1p AP600 Success Criteria MAAP4 Analysis
Broken Loop Steam Generator Pressure

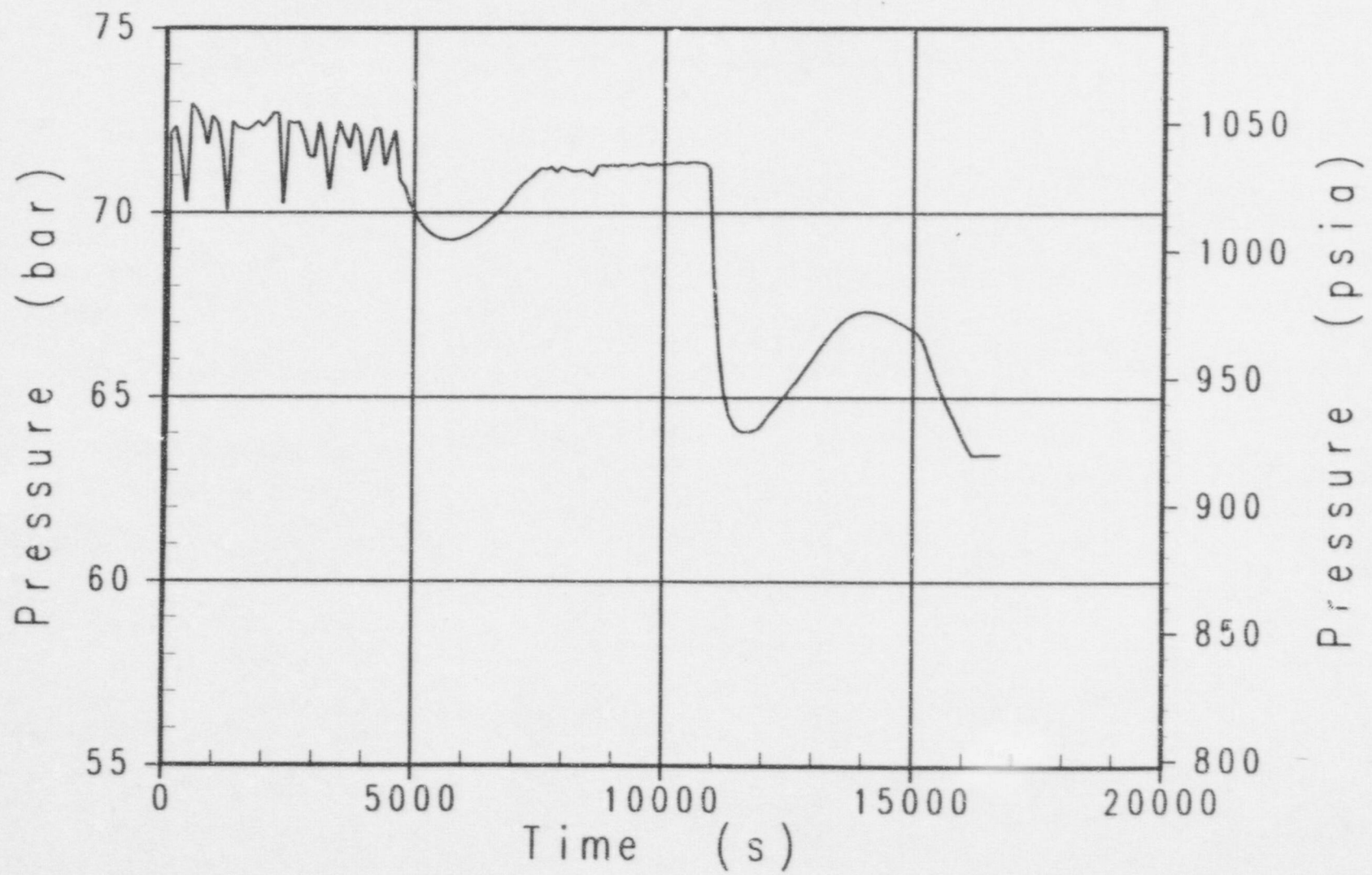

Case t1p AP600 Success Criteria MAAP4 Analysis
Primary System Pressure

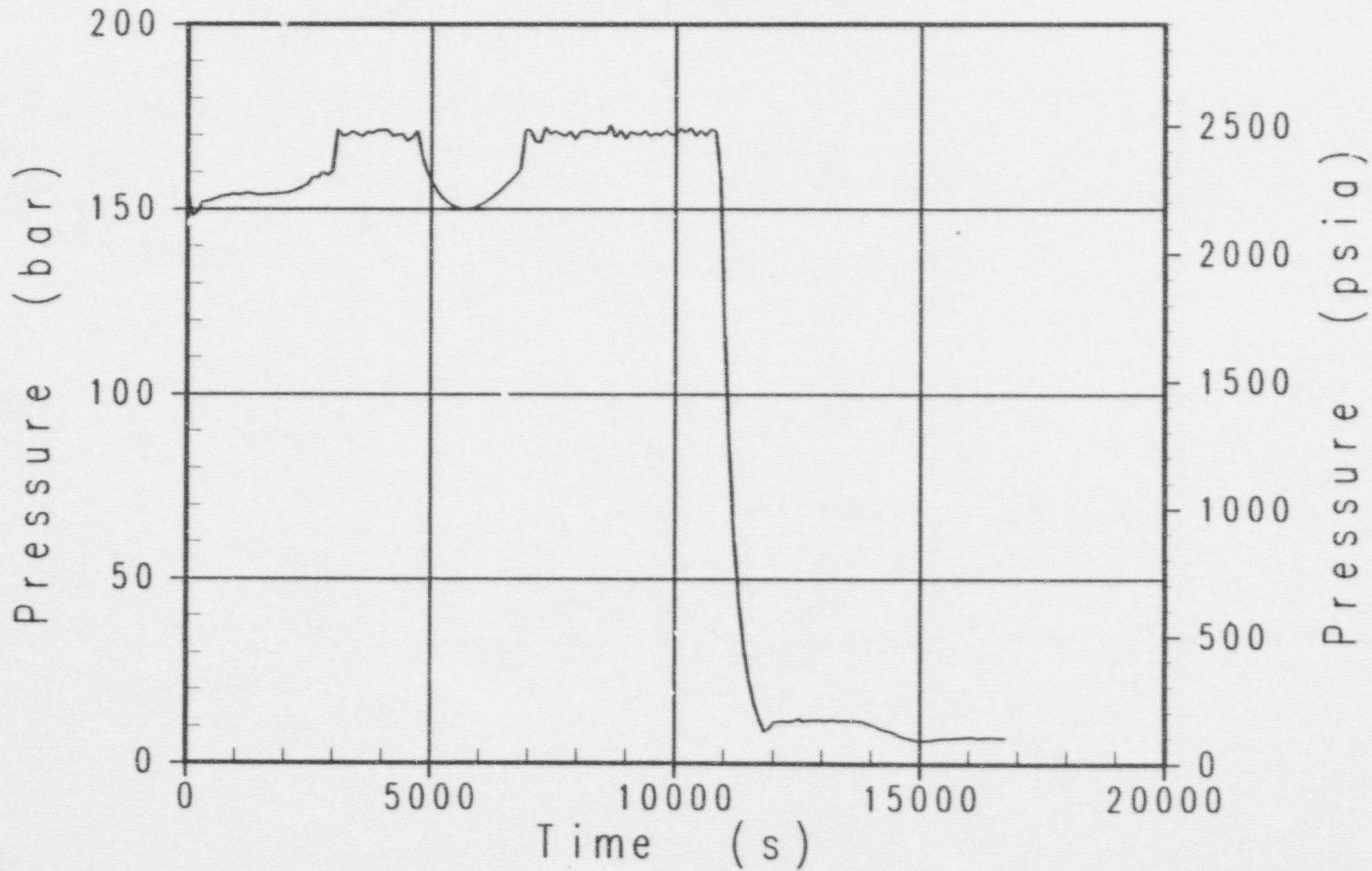

Case t1p AP600 Success Criteria MAAP4 Analysis
Containment Pressure

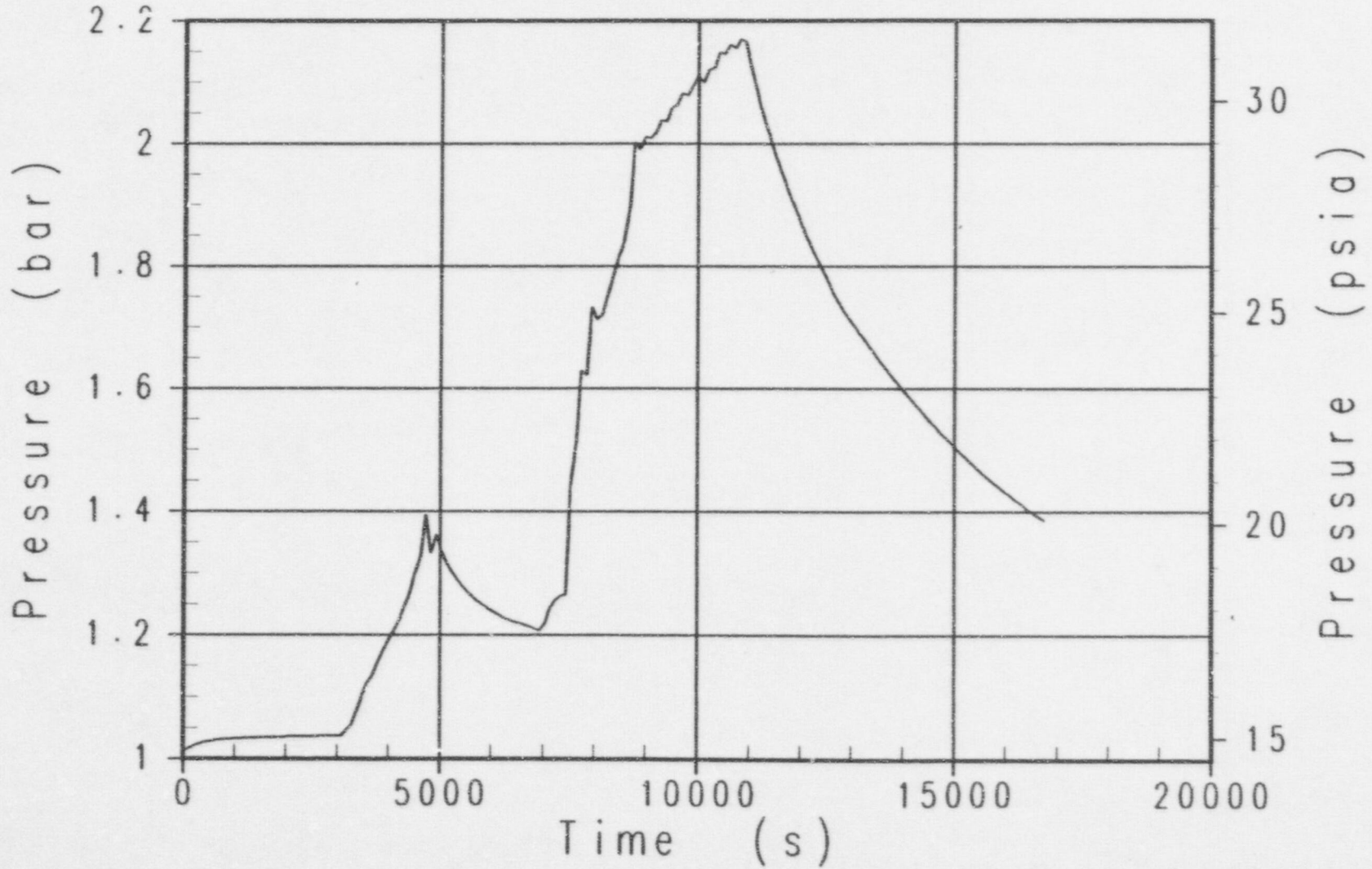

Case t1p AP600 Success Criteria MAAP4 Analysis
Unbroken Loop Steam Generator Pressure

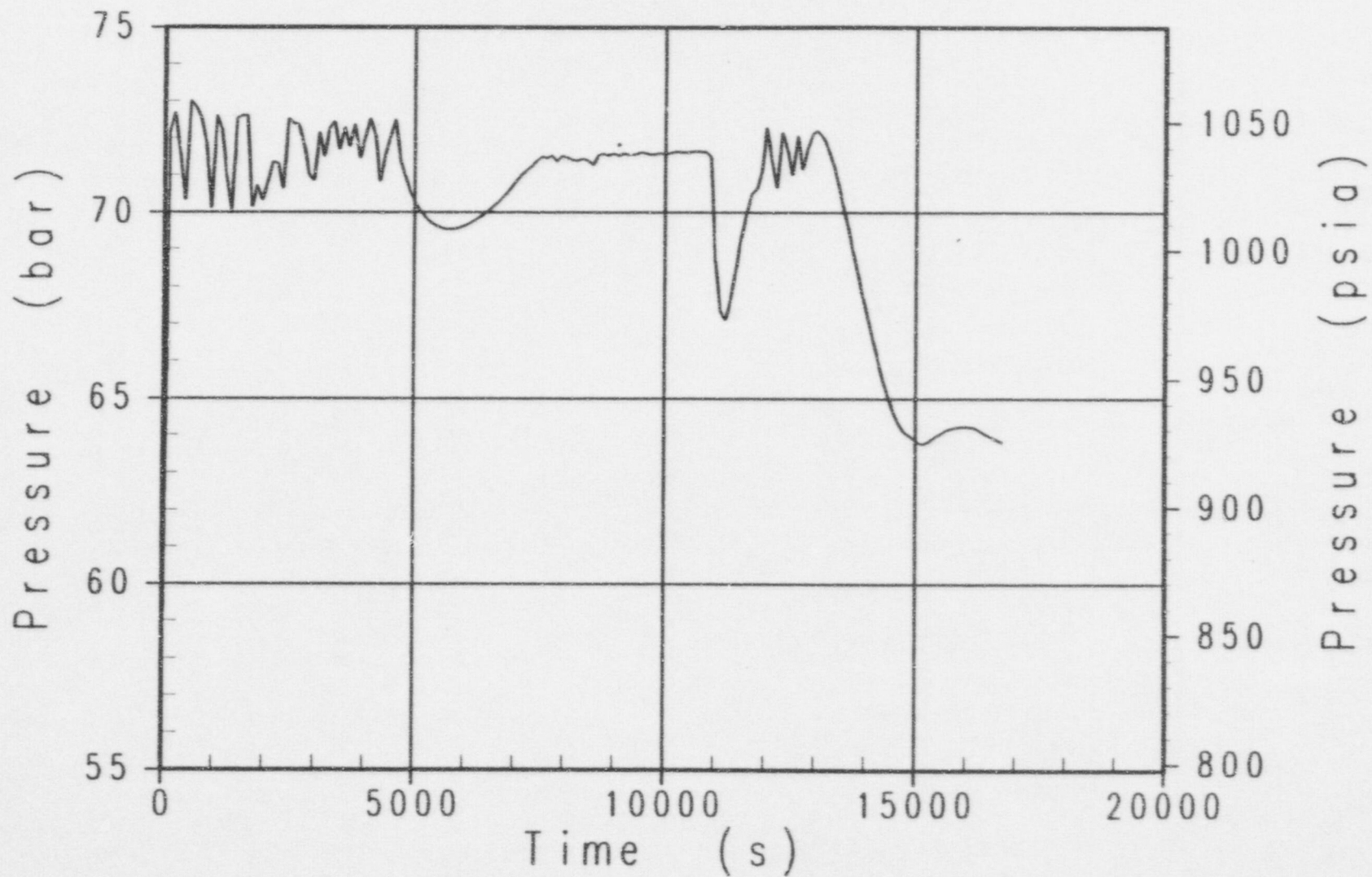

Case t1p AP600 Success Criteria MAAP4 Analysis
Decay Power

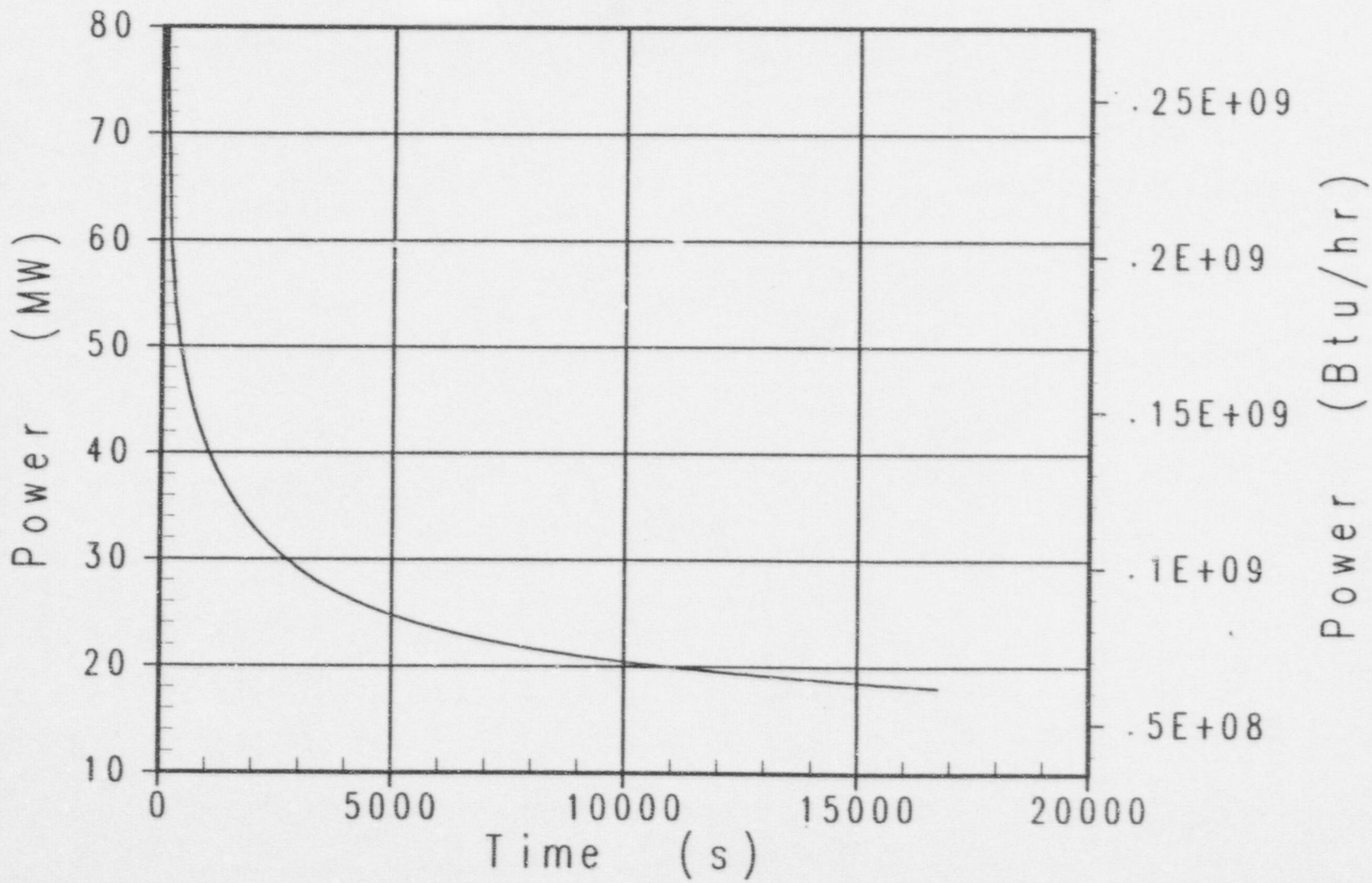

Case t1p AP600 Success Criteria MAAP4 Analysis
PRHR Heat Removal Rate

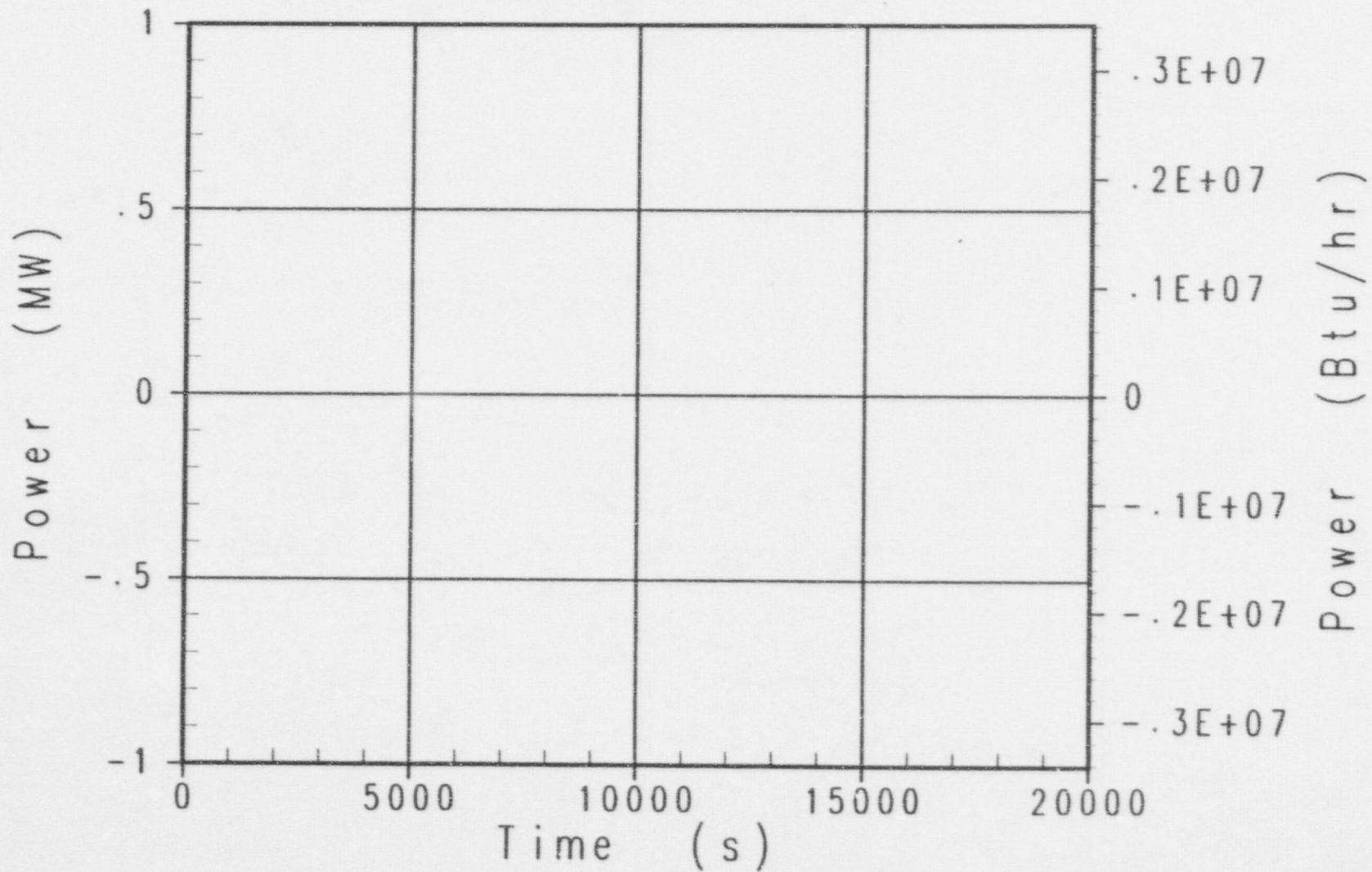

Case t1p AP600 Success Criteria MAAP4 Analysis
Peak Temperature in the Core

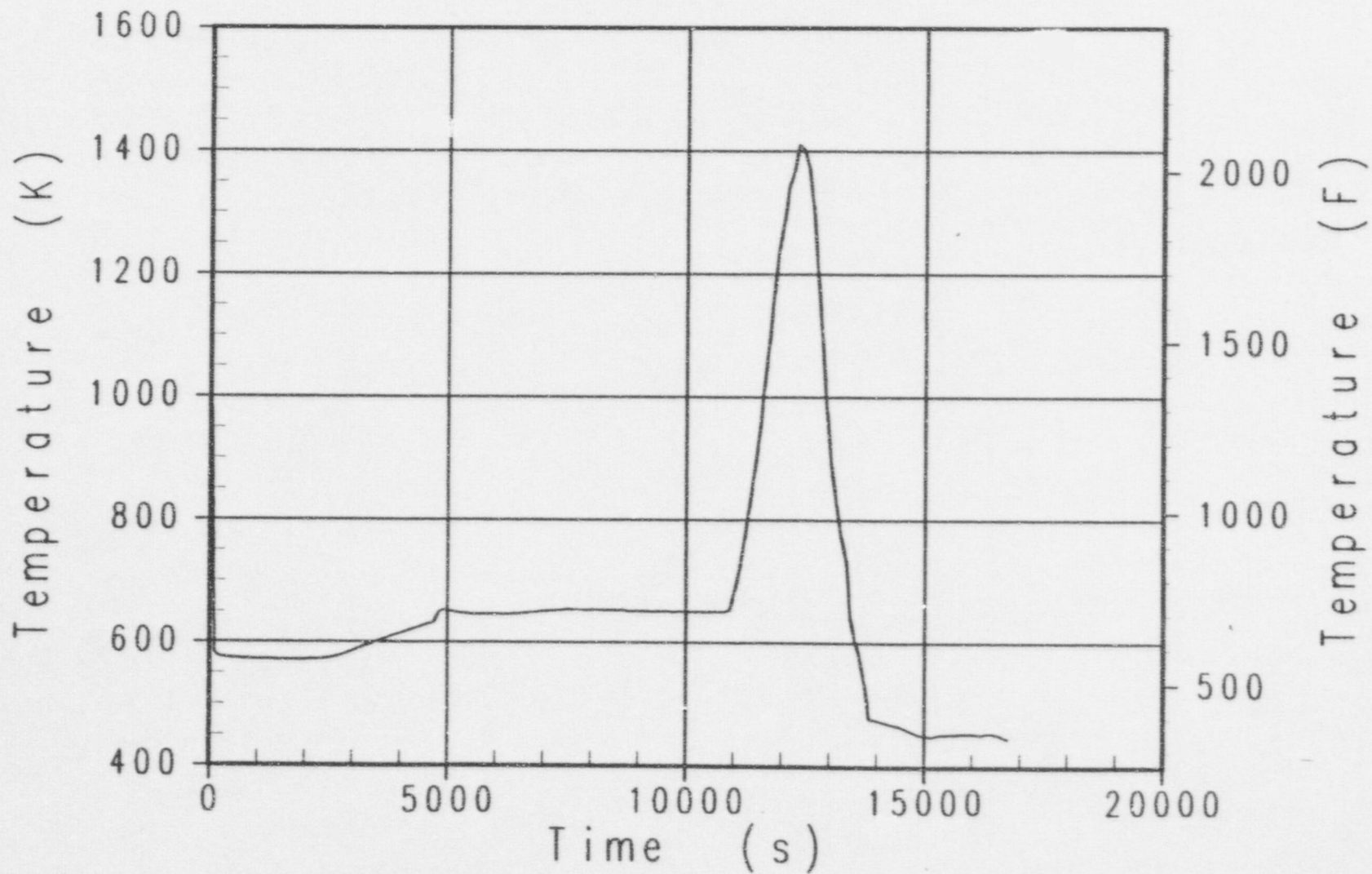

Case t1p AP600 Success Criteria MAAP4 Analysis
Cold Leg Water Temperature

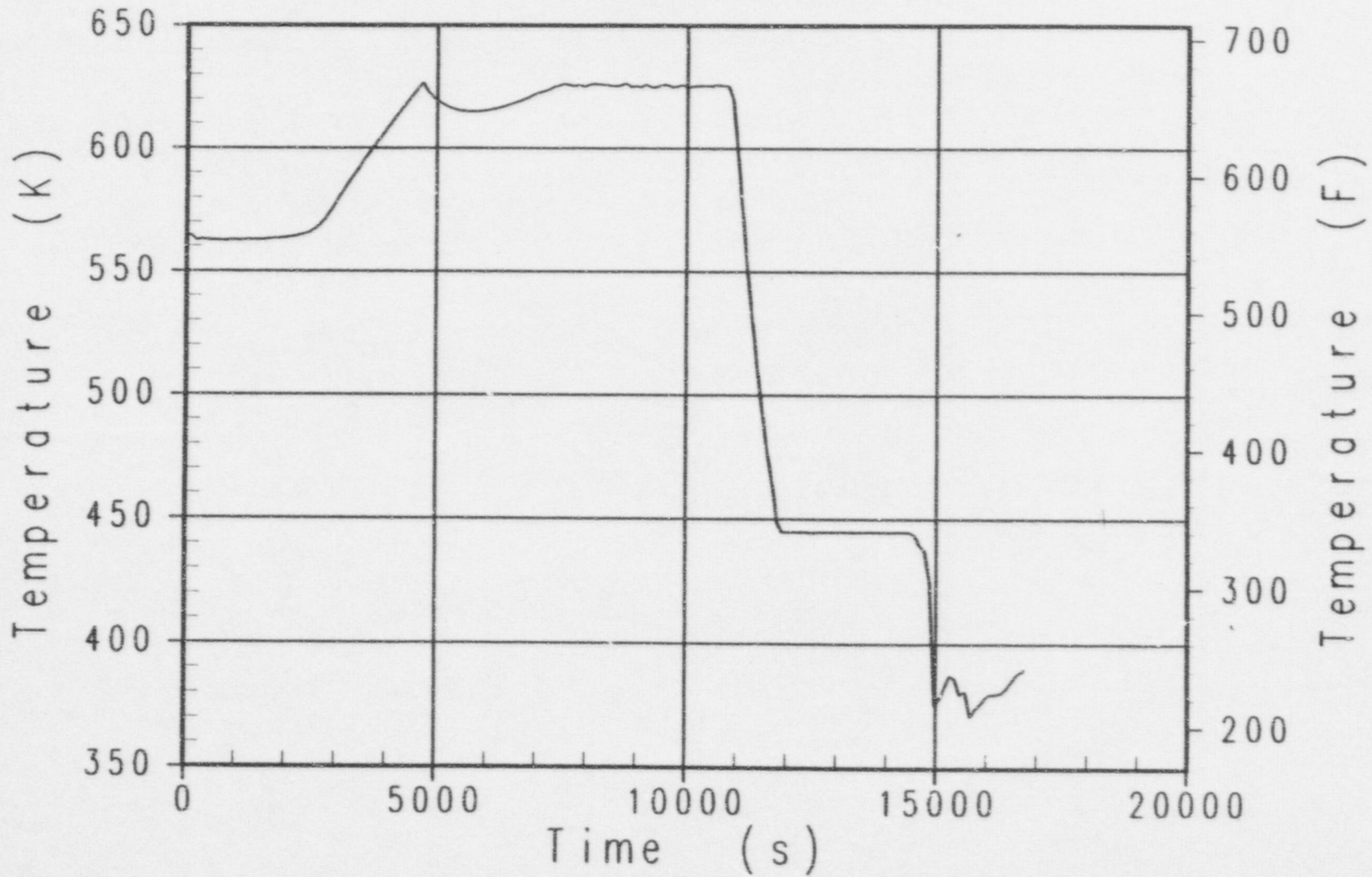

Case t1p AP600 Success Criteria MAAP4 Analysis
Core Water Temperature

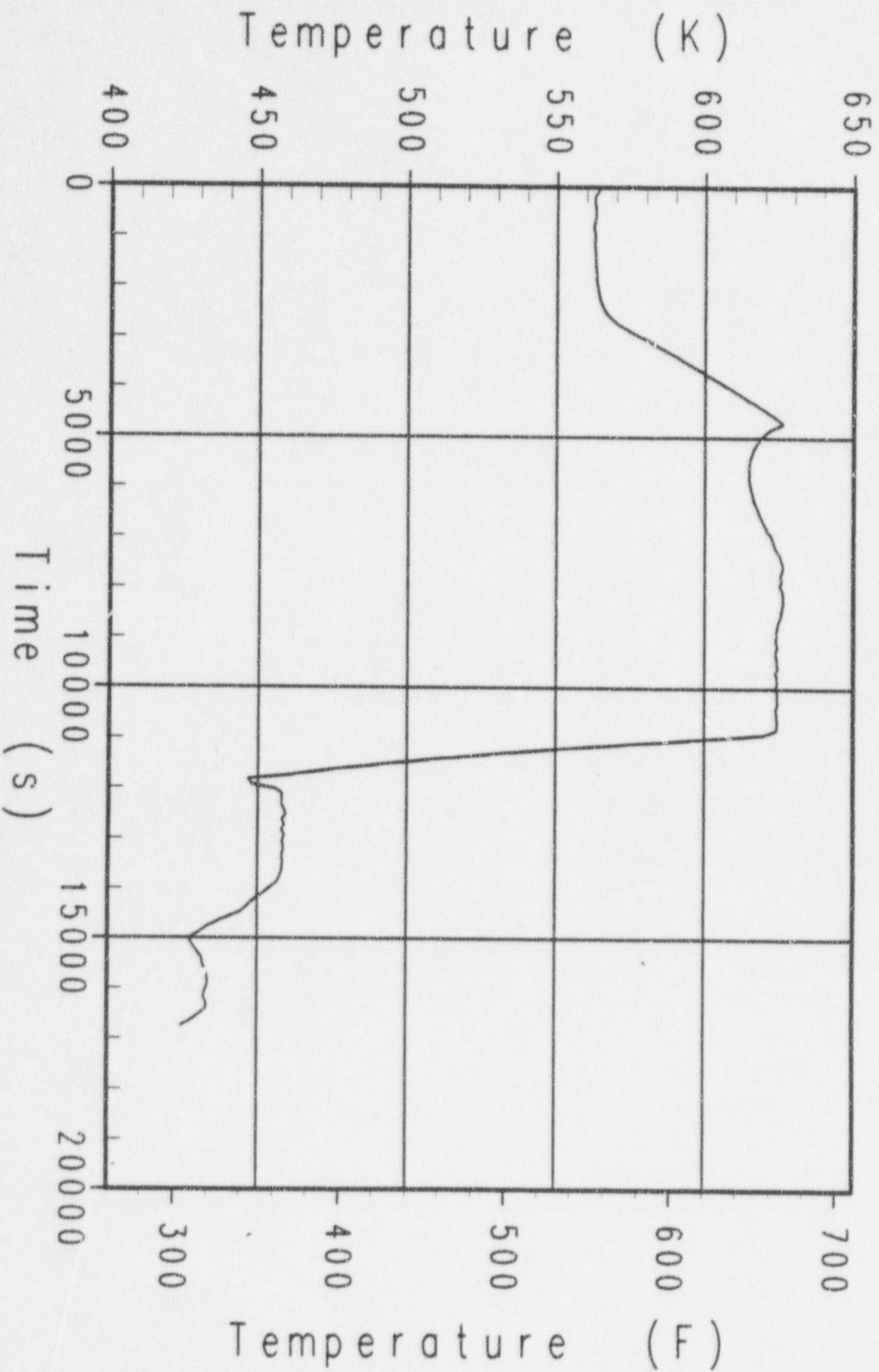

Case t1p AP600 Success Criteria MAAP4 Analysis
RPV Downcomer Water Temperature

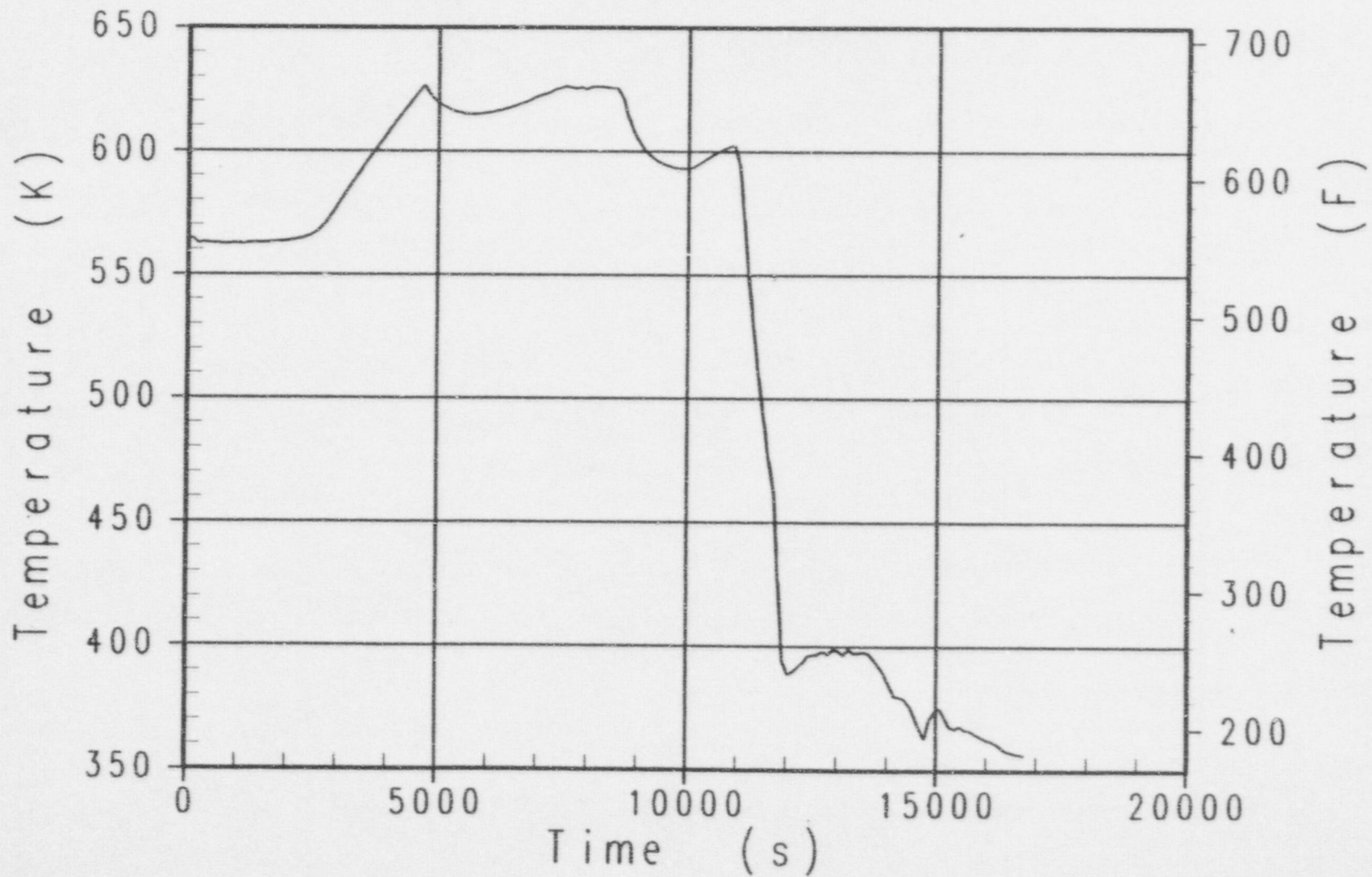

Case t1p AP600 Success Criteria MAAP4 Analysis
IRWST Water Temperature

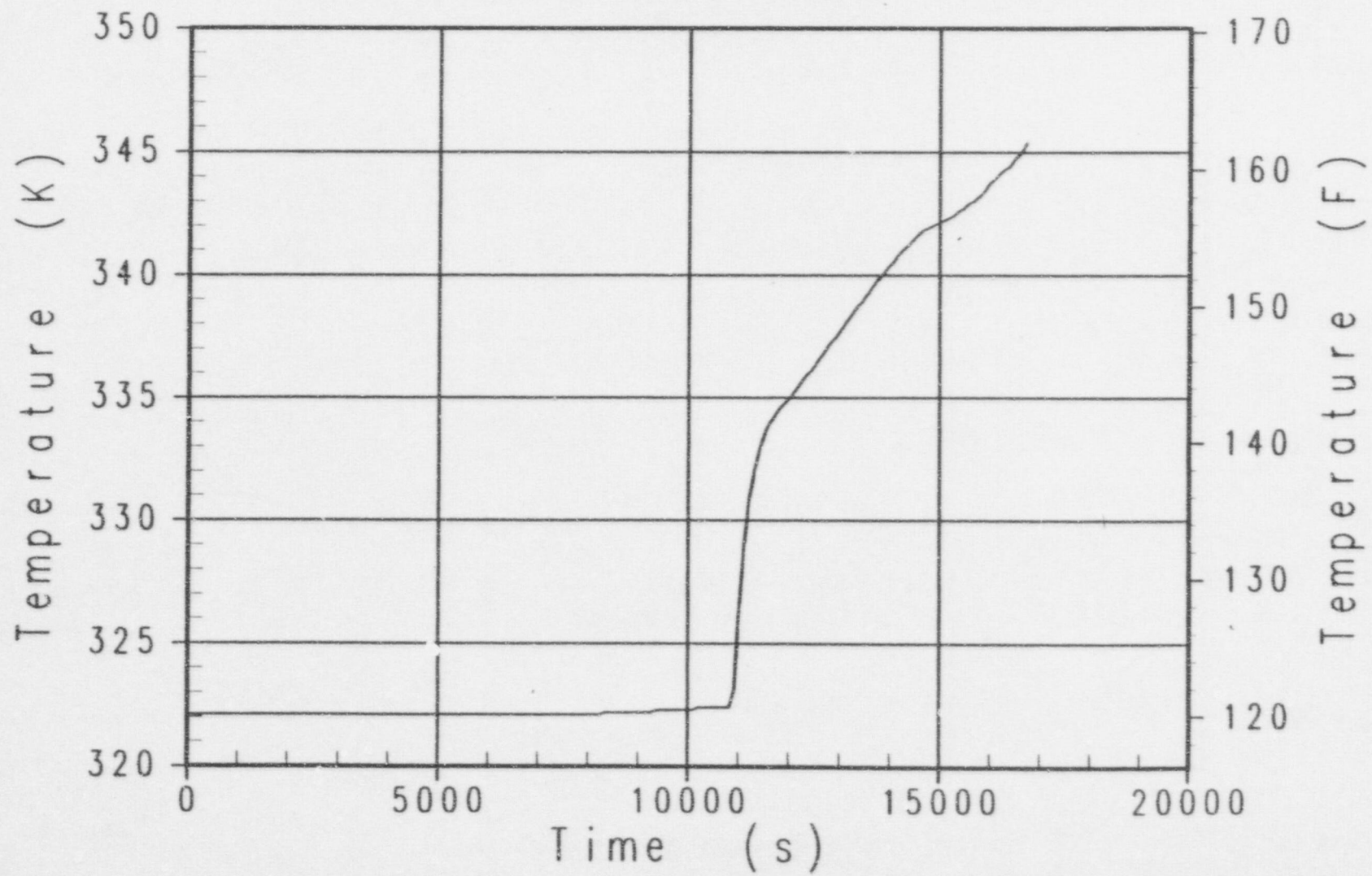

Case t1p AP600 Success Criteria MAAP4 Analysis
Accumulator and NRHR Injection Flowrate

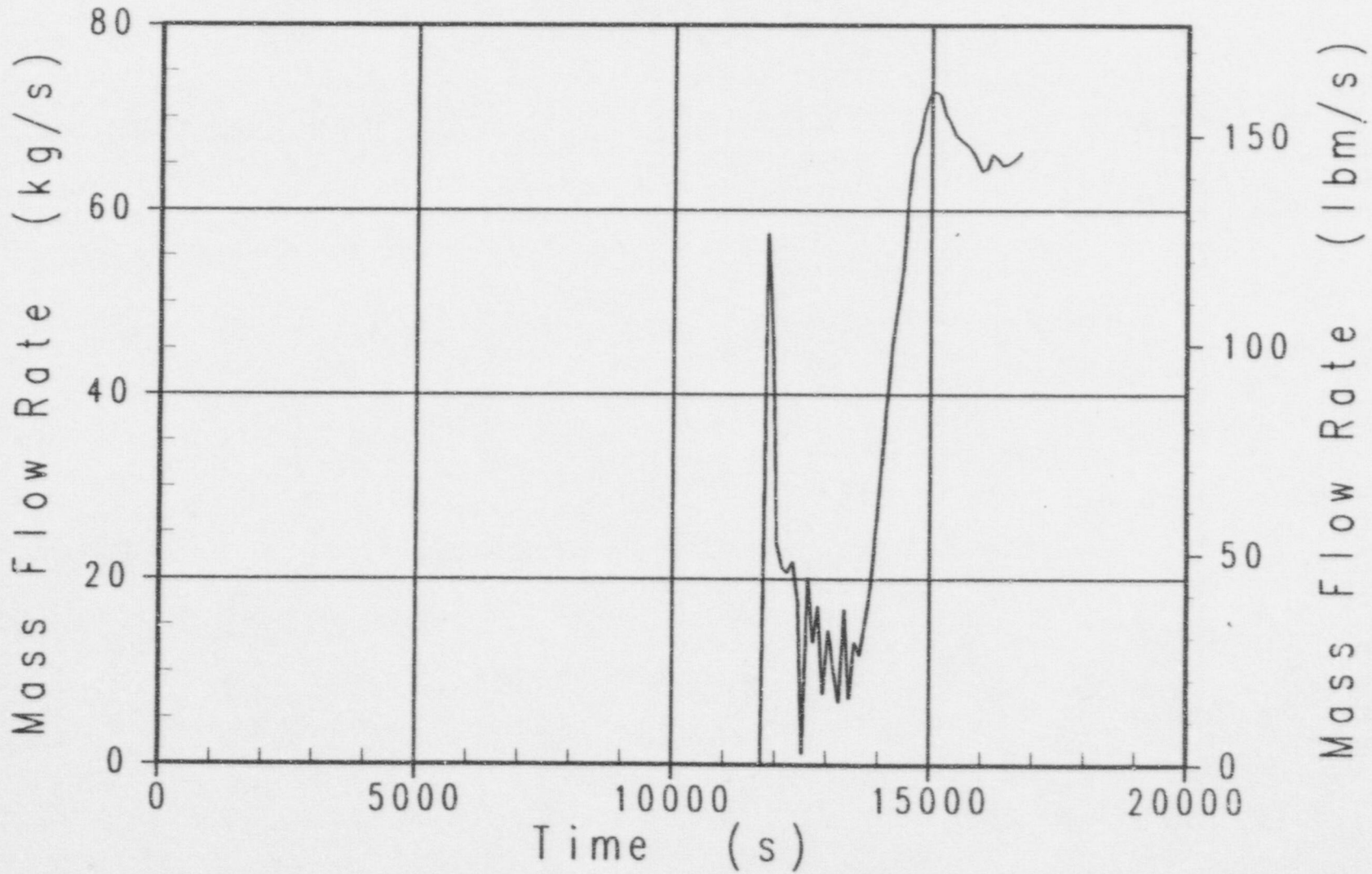

Case t1p AP600 Success Criteria MAAP4 Analysis
RCS Break Gas Flowrate

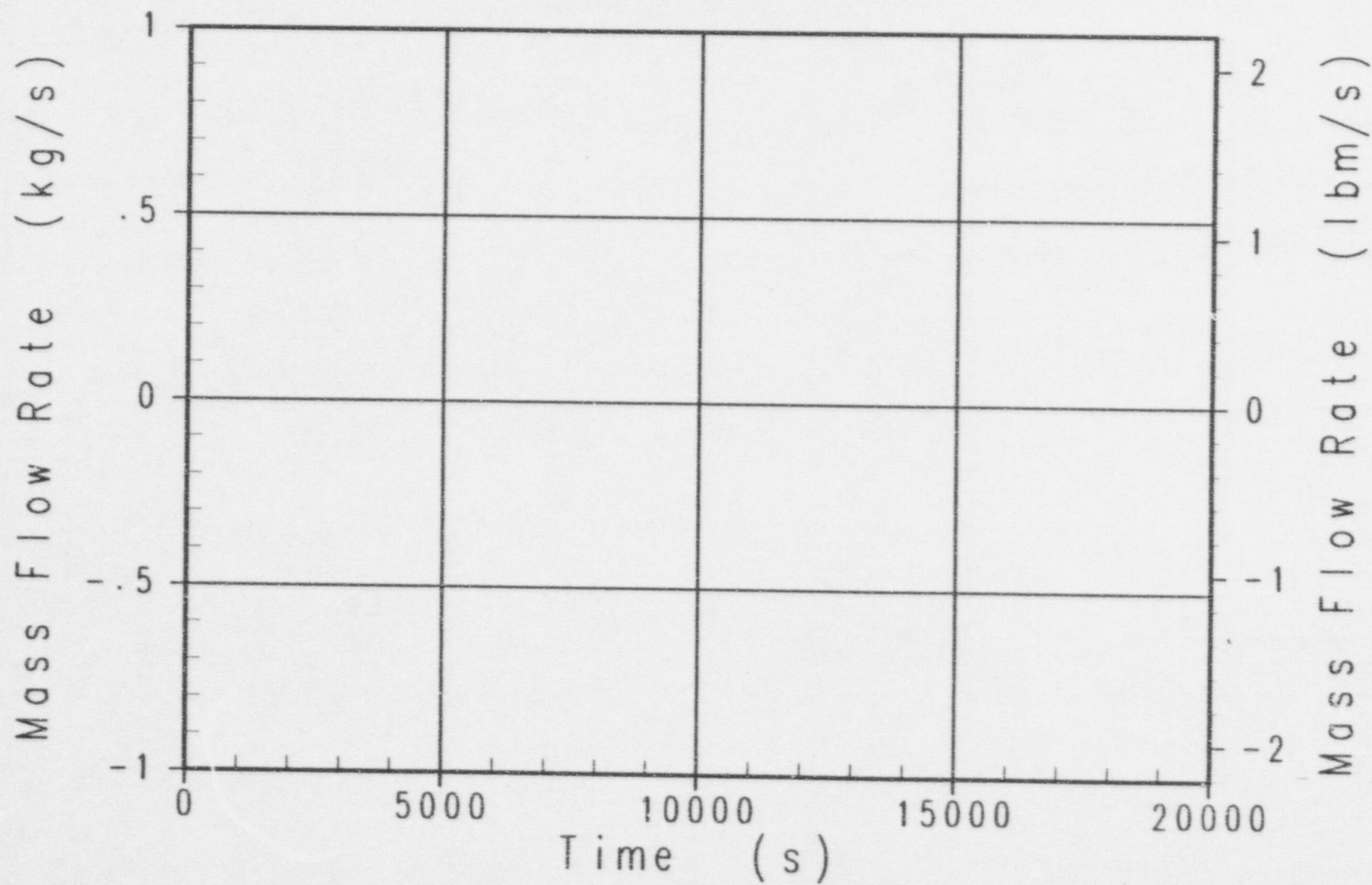

Case t1p AP600 Success Criteria MAAP4 Analysis
ADS Stage 4 Gas Flowrate

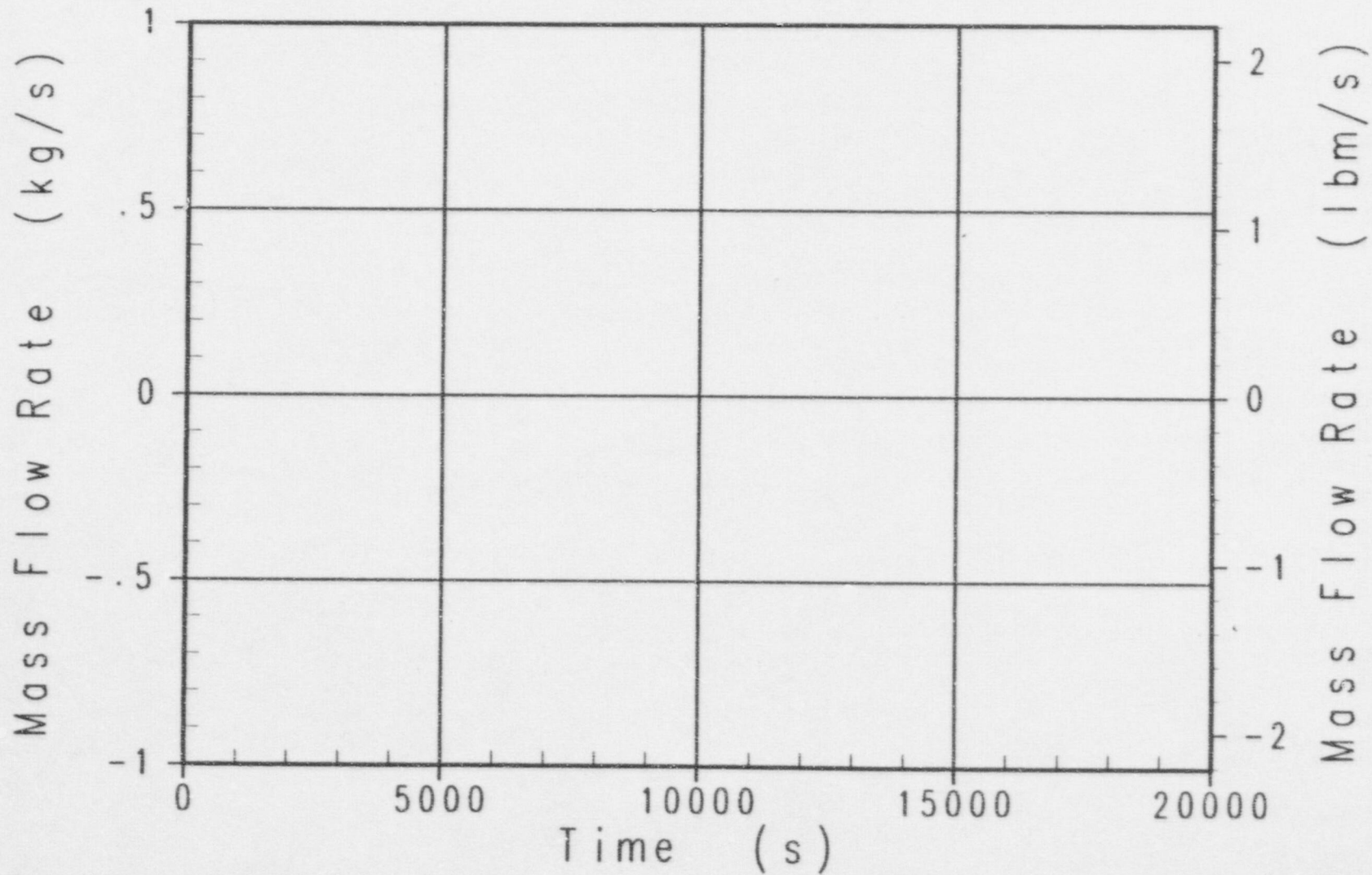

Case 11p AP600 Success Criteria MAAp4 Analysis
Safety Valve and ADS Stages 1-3 Gas Flowrate

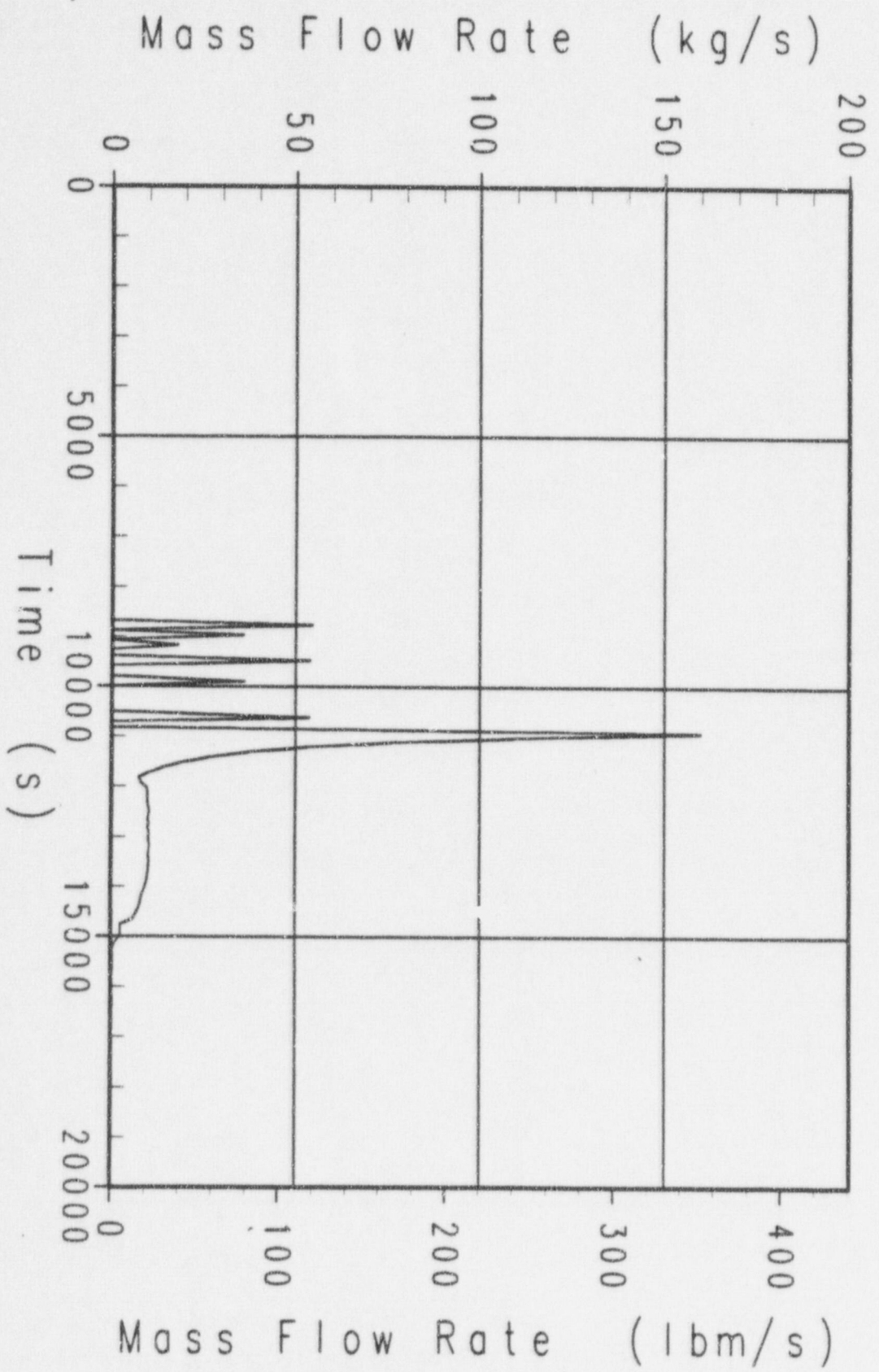

Case t1p AP600 Success Criteria MAAP4 Analysis
RCS Break Liquid Flowrate

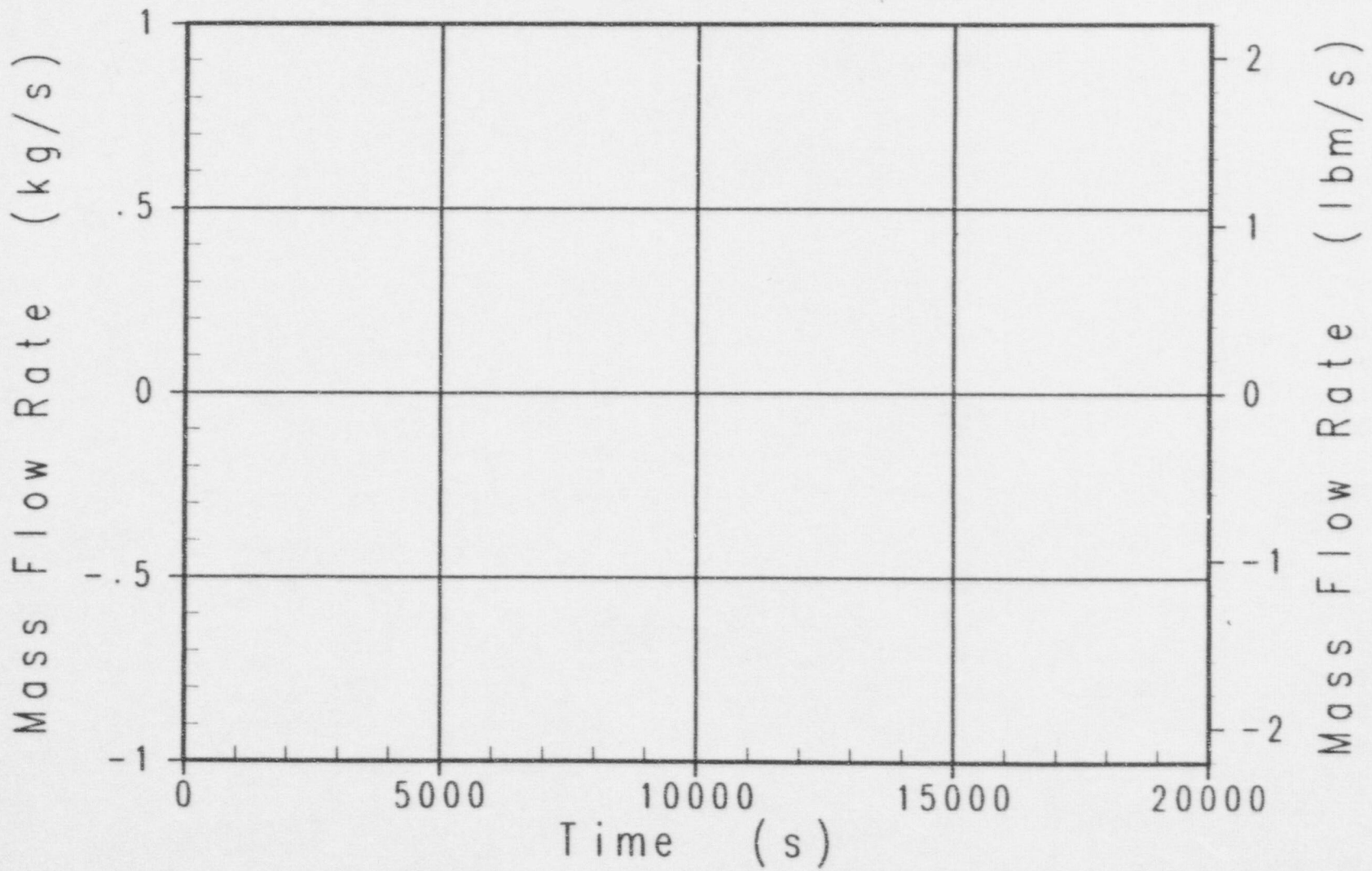

Case t1p AP600 Success Criteria MAAP4 Analysis
ADS Stage 4 Liquid Flowrate

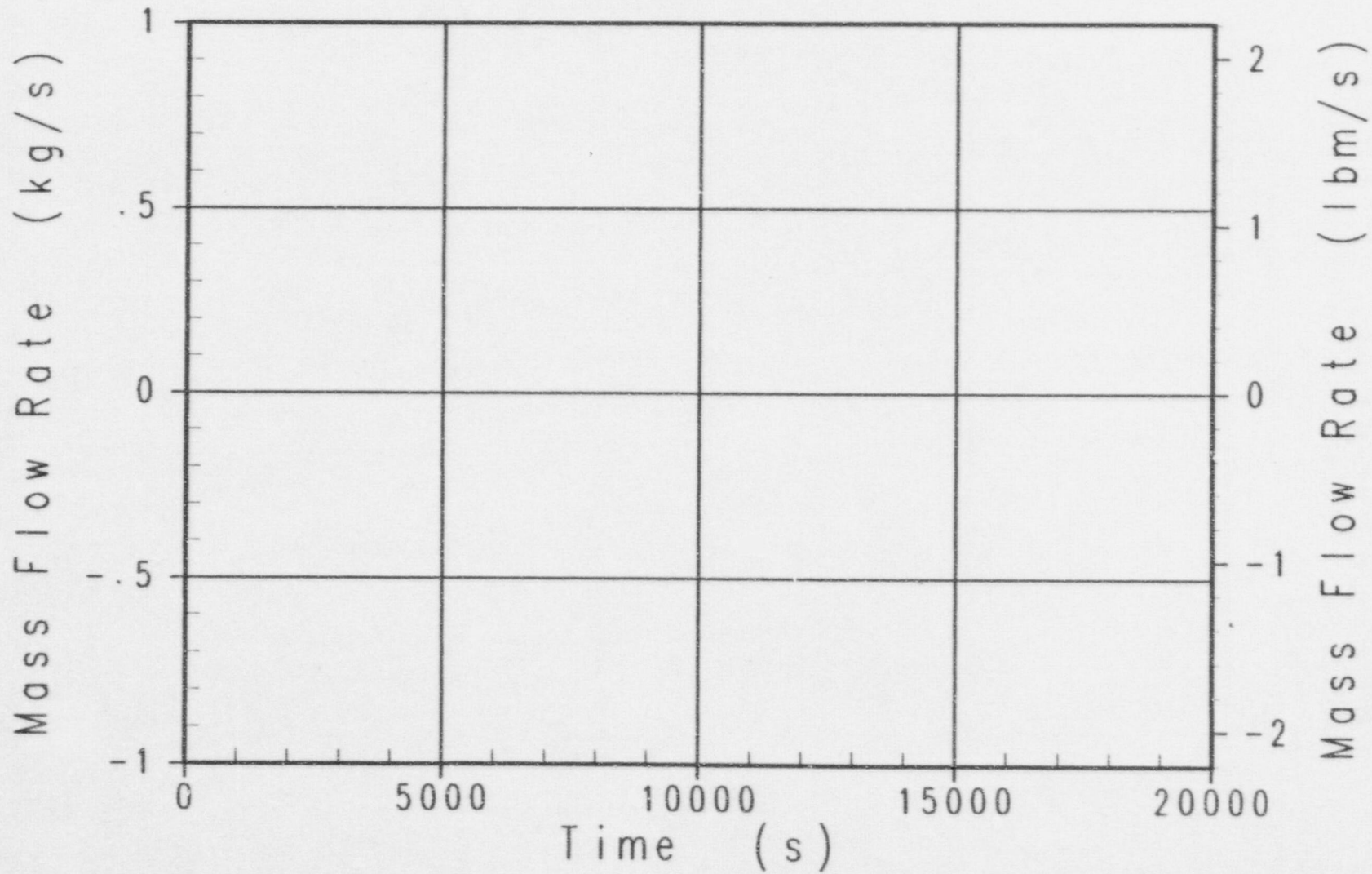

Case t1p AP600 Success Criteria MAAP4 Analysis
IRWST Injection Flowrate (neg. means into RCS)

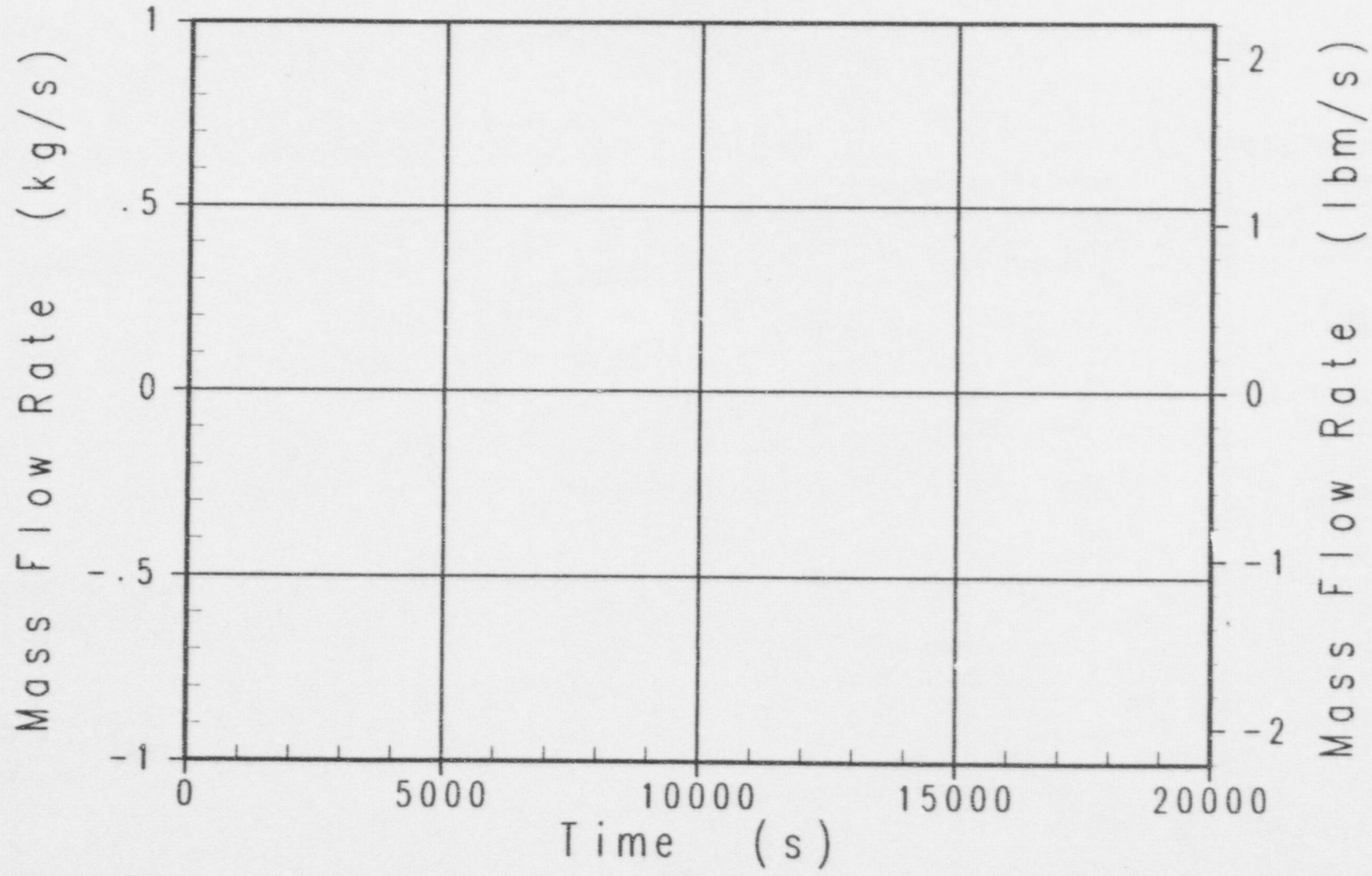

Case t1p AP600 Success Criteria MAAP4 Analysis
CMT-1 Injection Flowrate

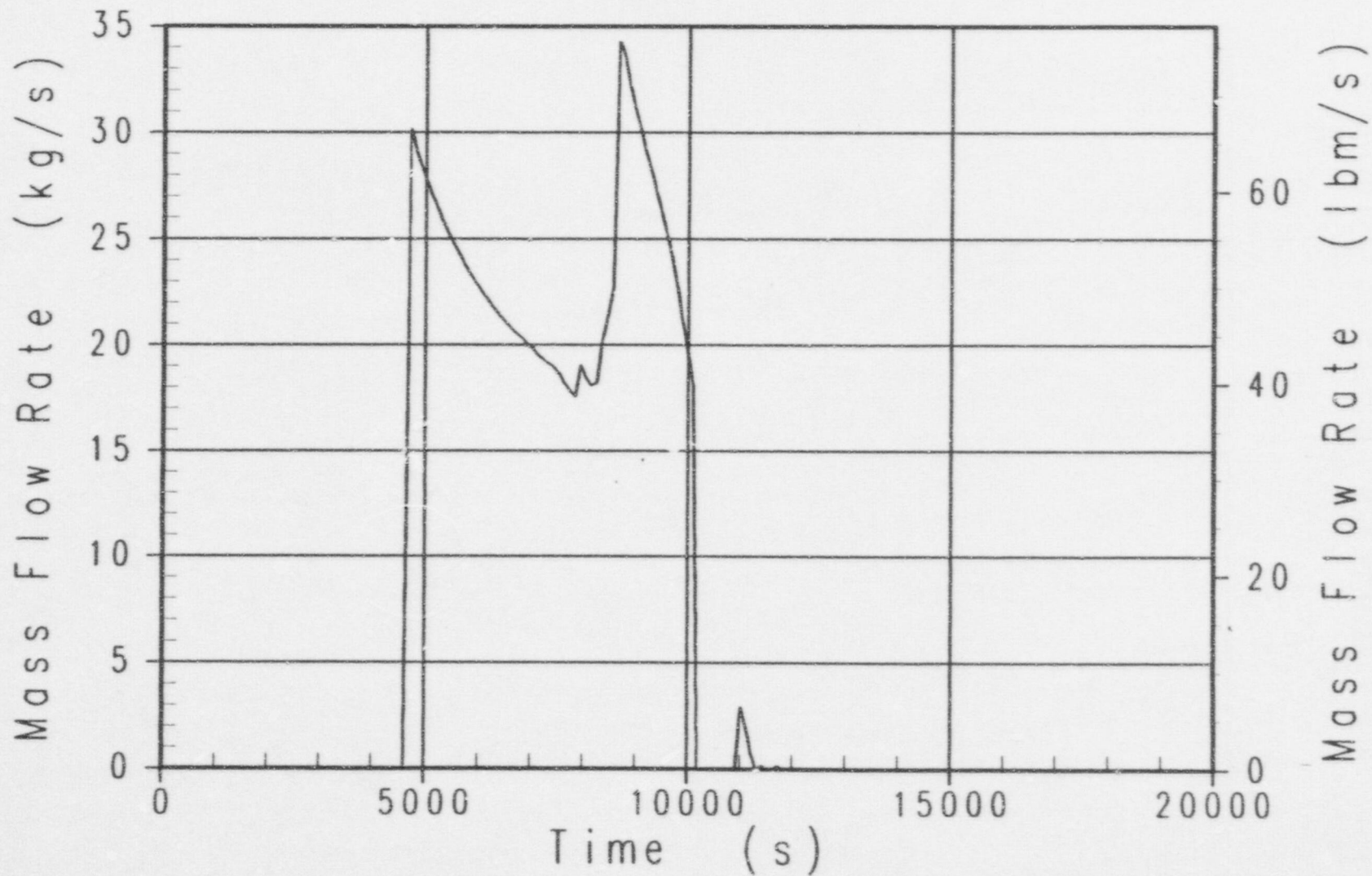

Case t1p AP600 Success Criteria MAAP4 Analysis
Safety Valve and ADS Stages 1-3 Liquid Flowrate

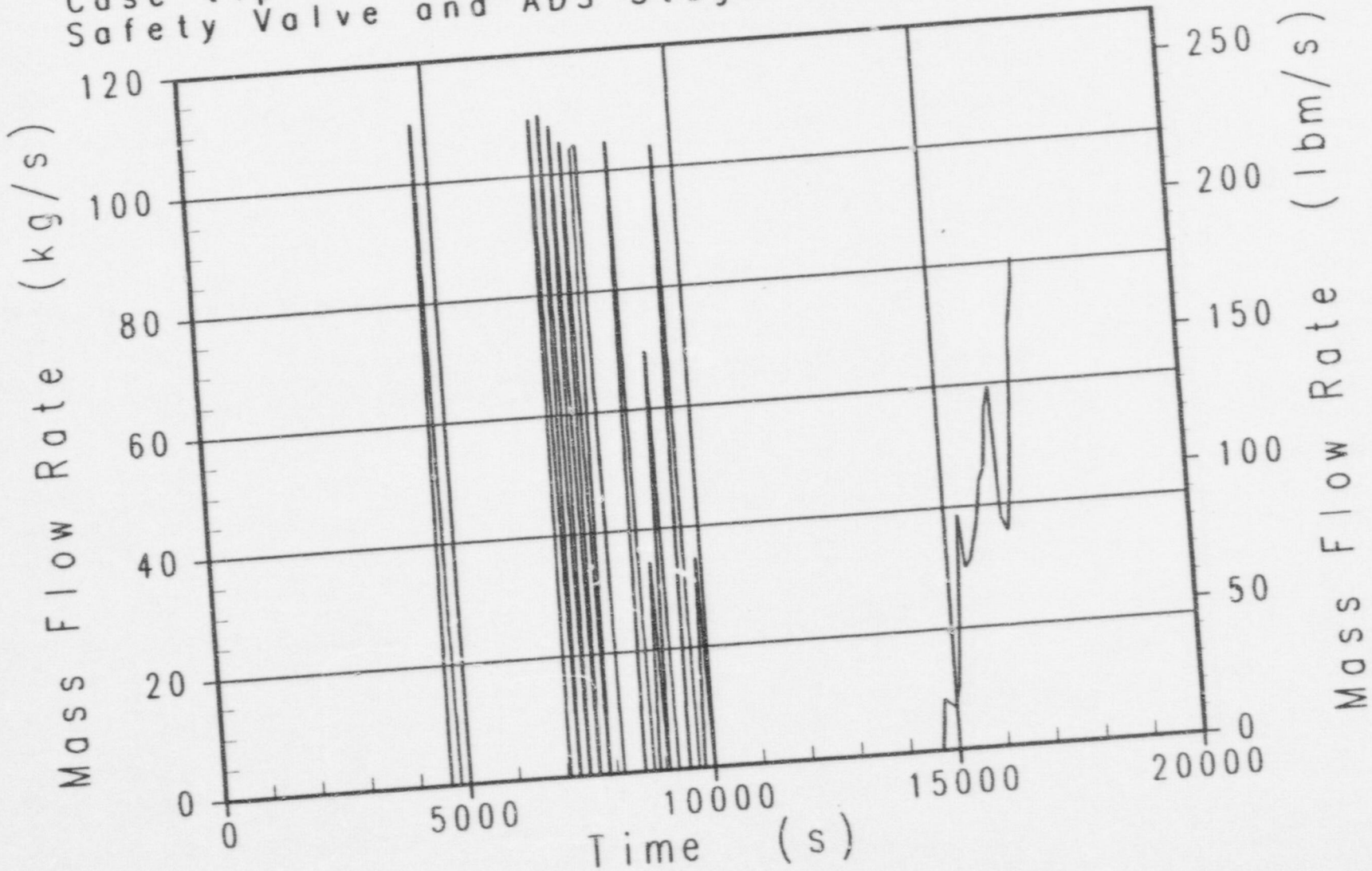

Case t1p AP600 Success Criteria MAAP4 Analysis
CMT-1 Water Level

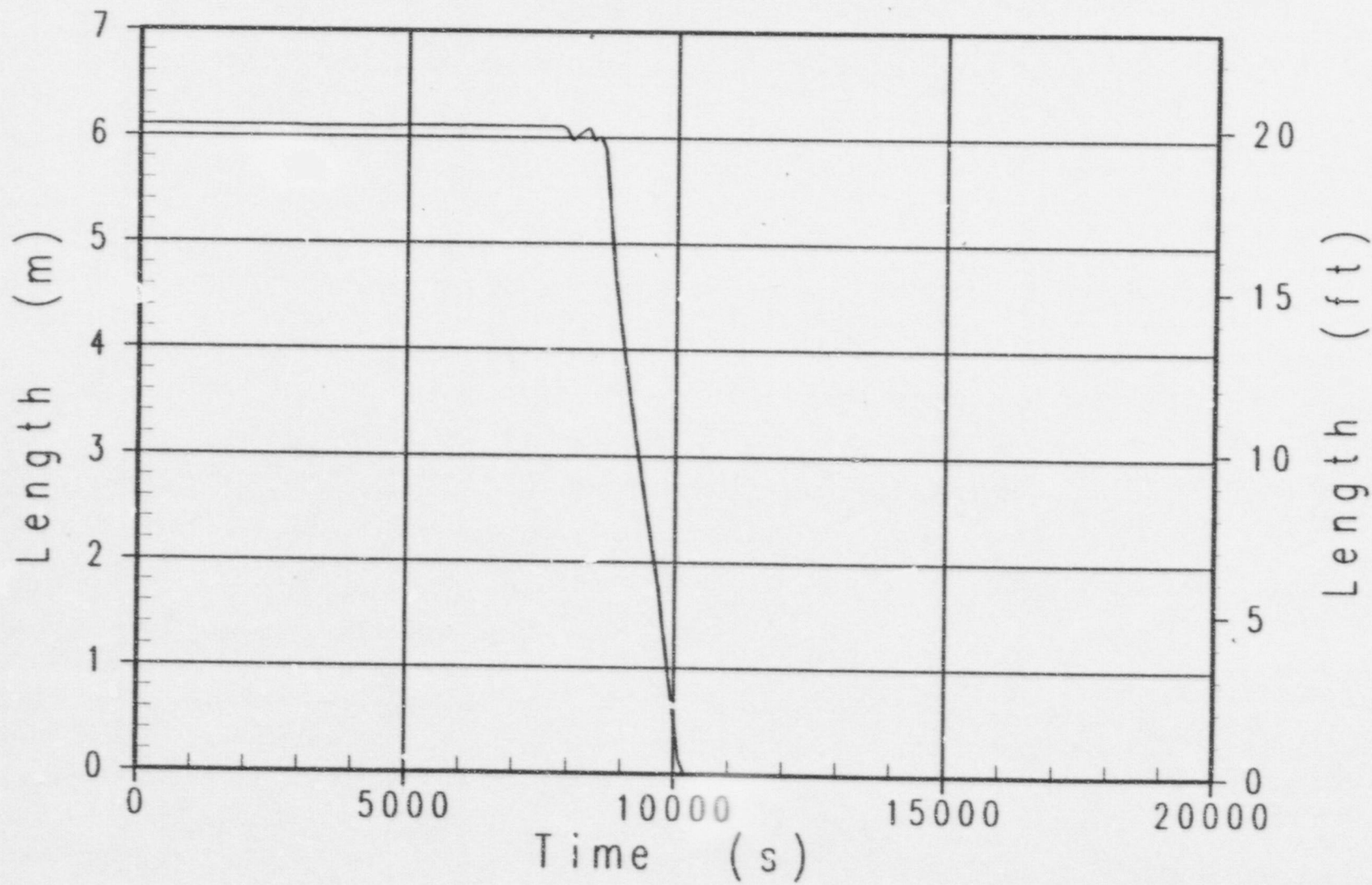

Case t1p AP600 Success Criteria MAAP4 Analysis
Pressurizer Water Level (From Pzr Bottom)

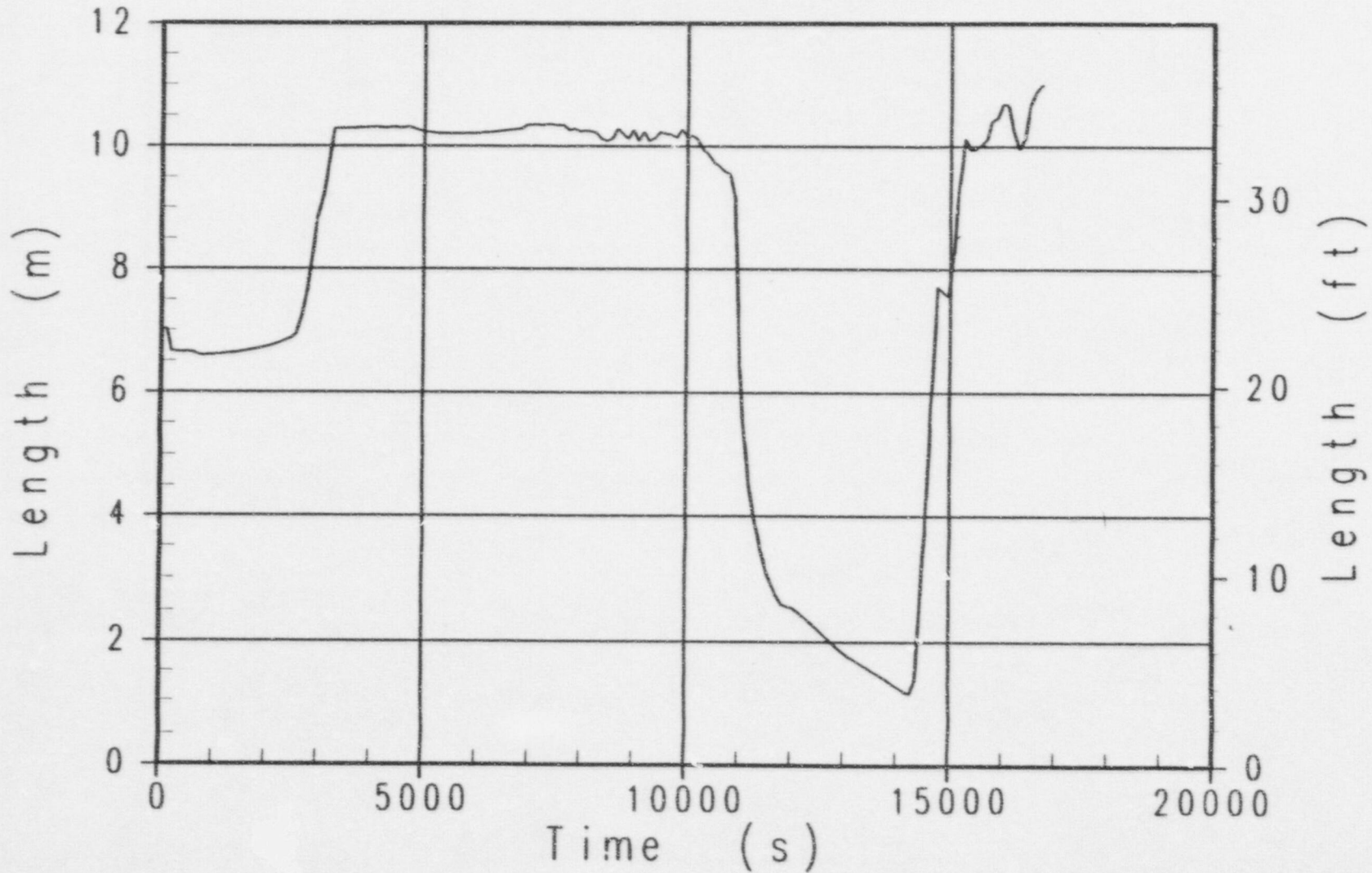

Case t1f AP600 Success Criteria MAAP4 Analysis
Broken Loop Steam Generator Pressure

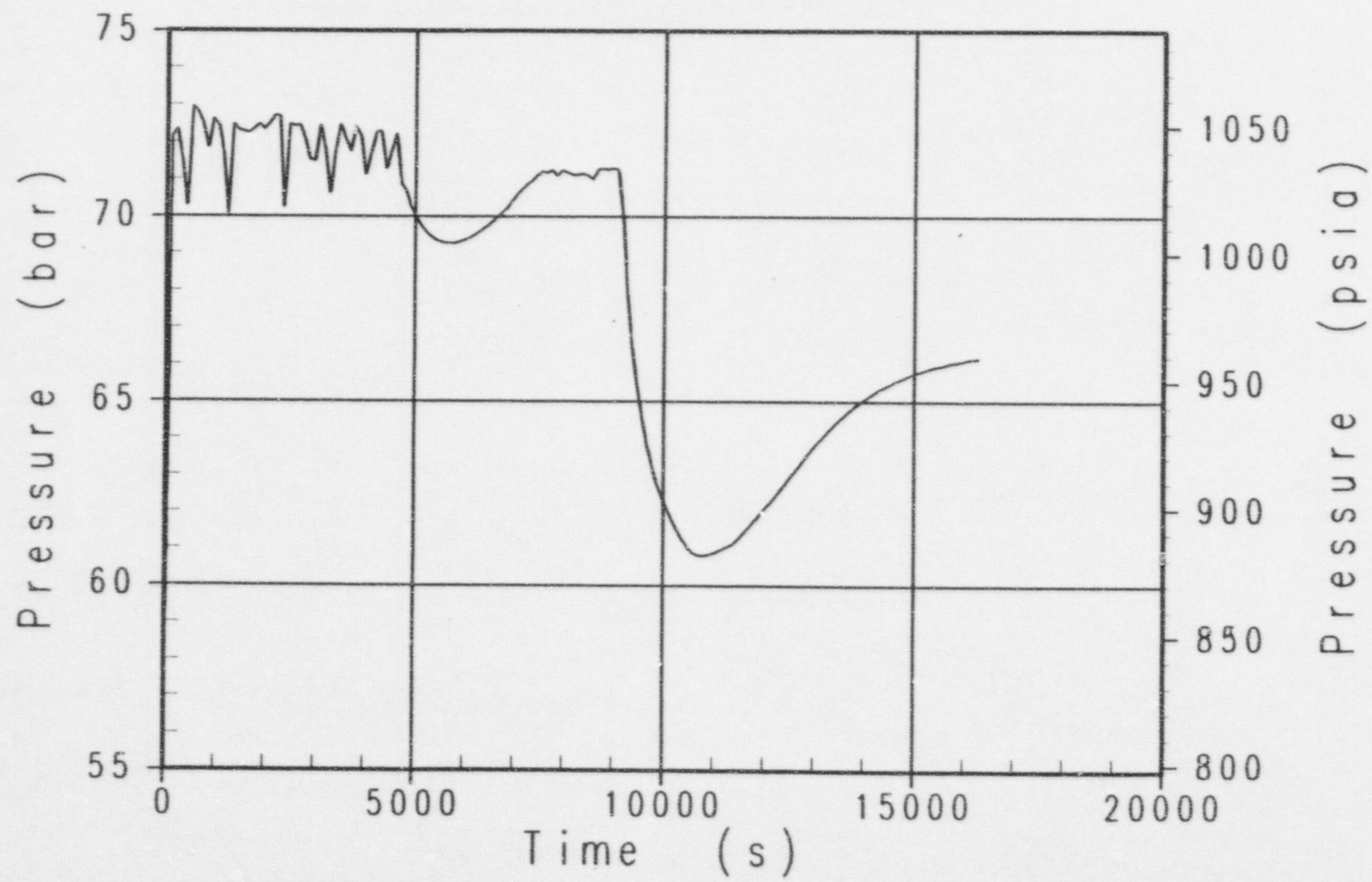

Case t1f AP600 Success Criteria MAAP4 Analysis
Primary System Pressure

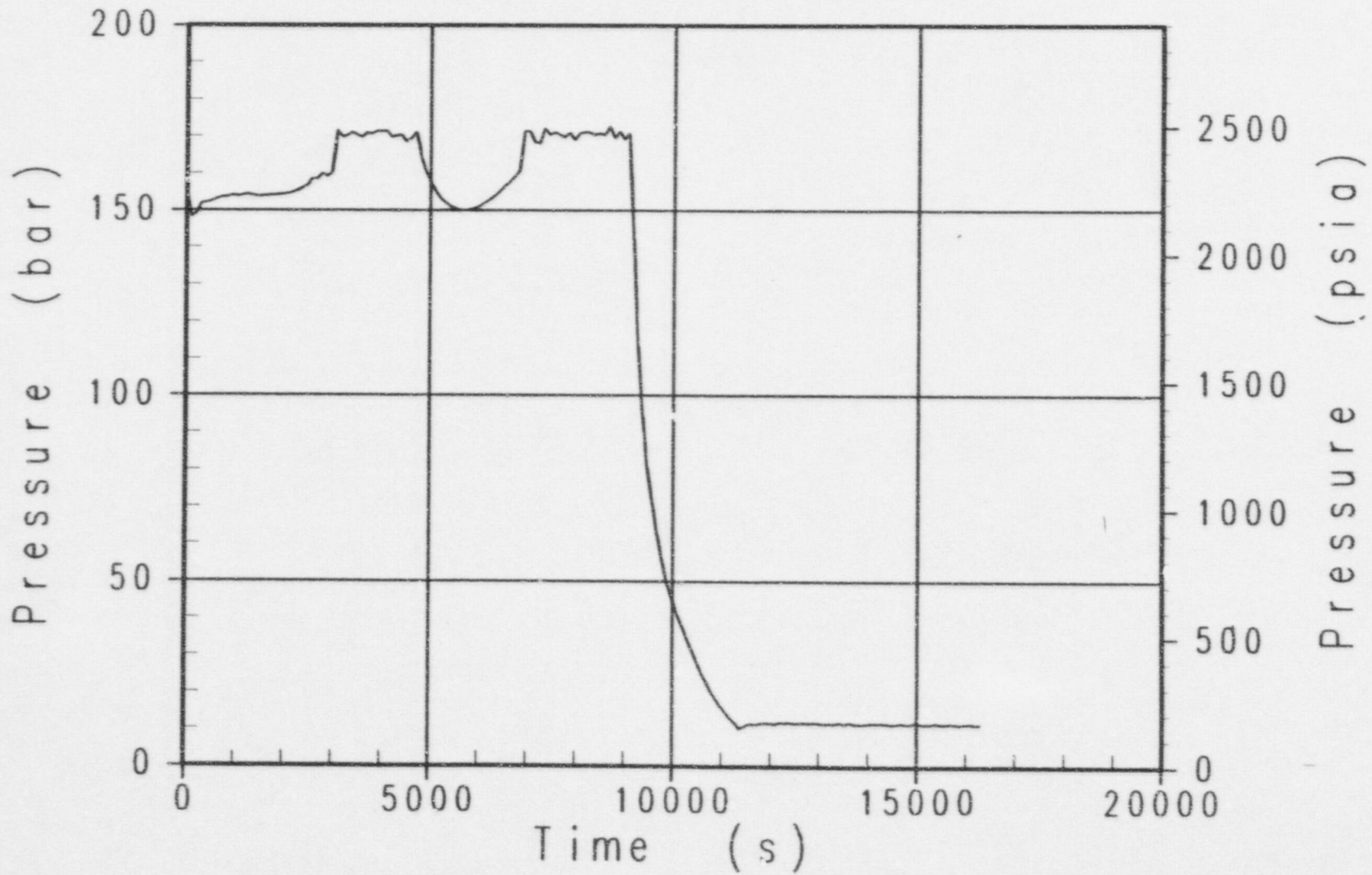

Case t1f AP600 Success Criteria MAAP4 Analysis
Containment Pressure

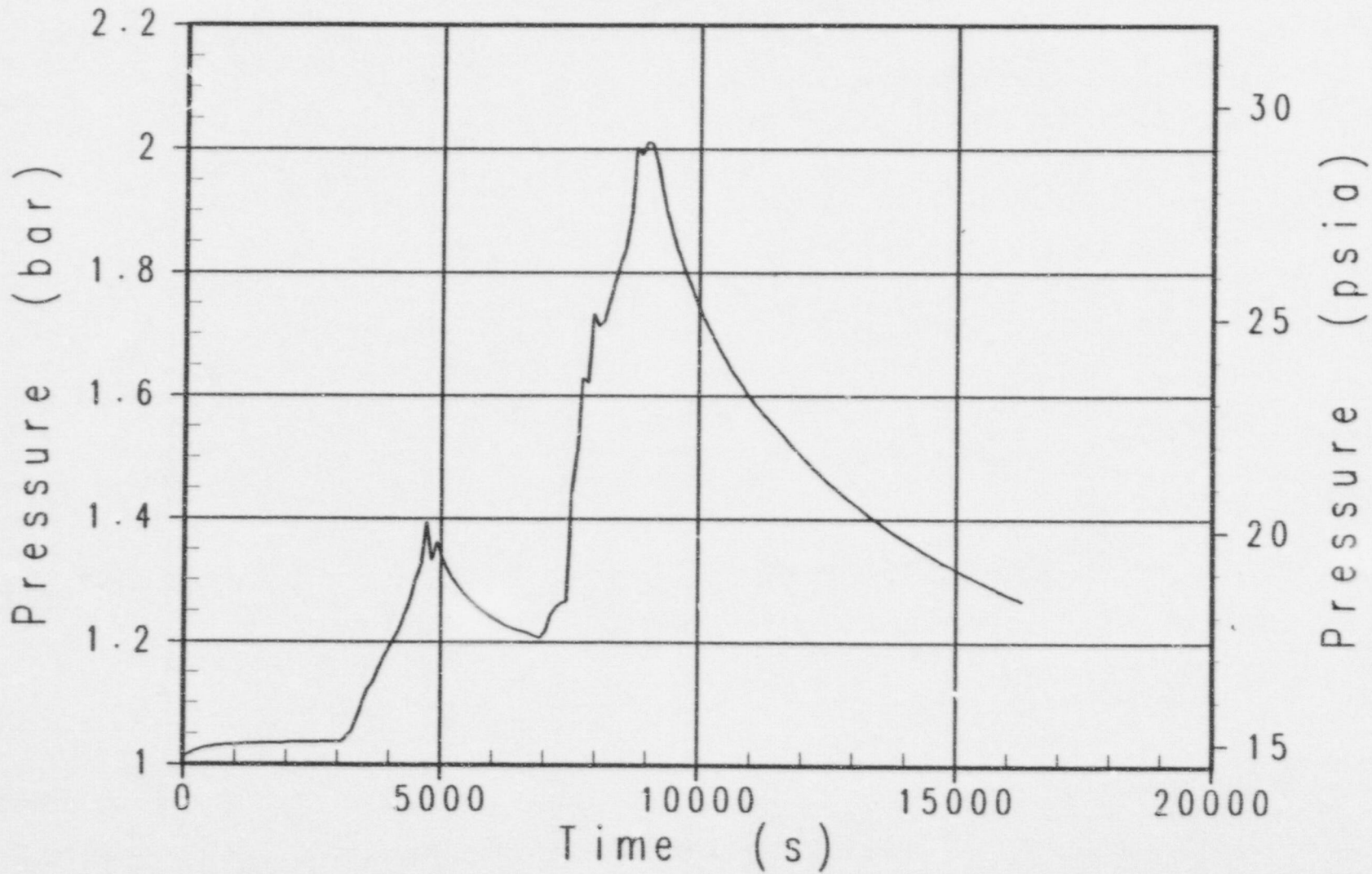

Case t1f AP600 Success Criteria MAAP4 Analysis
Decay Power

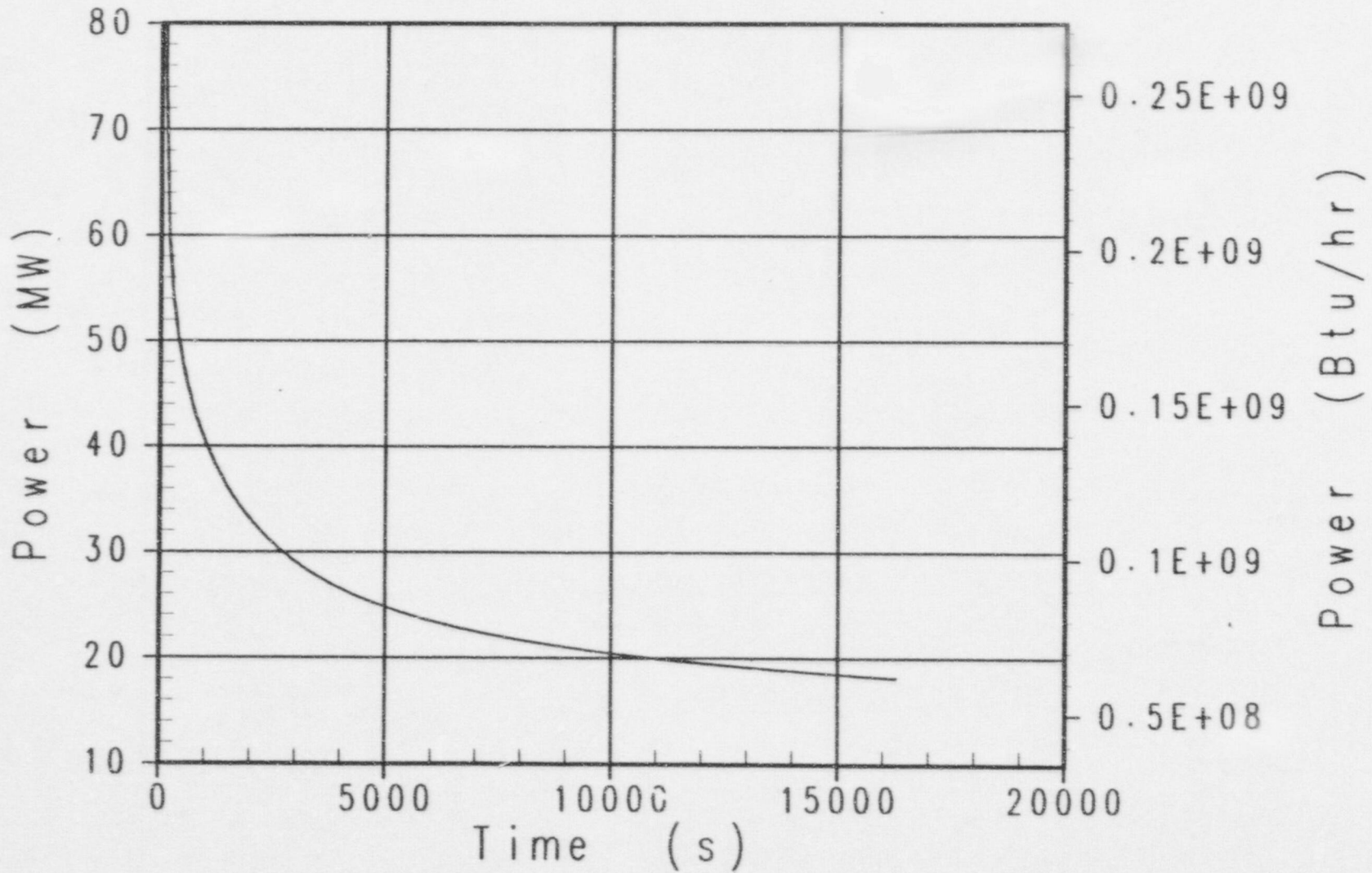

Case t1f AP600 Success Criteria MAAP4 Analysis
PRHR Heat Removal Rate

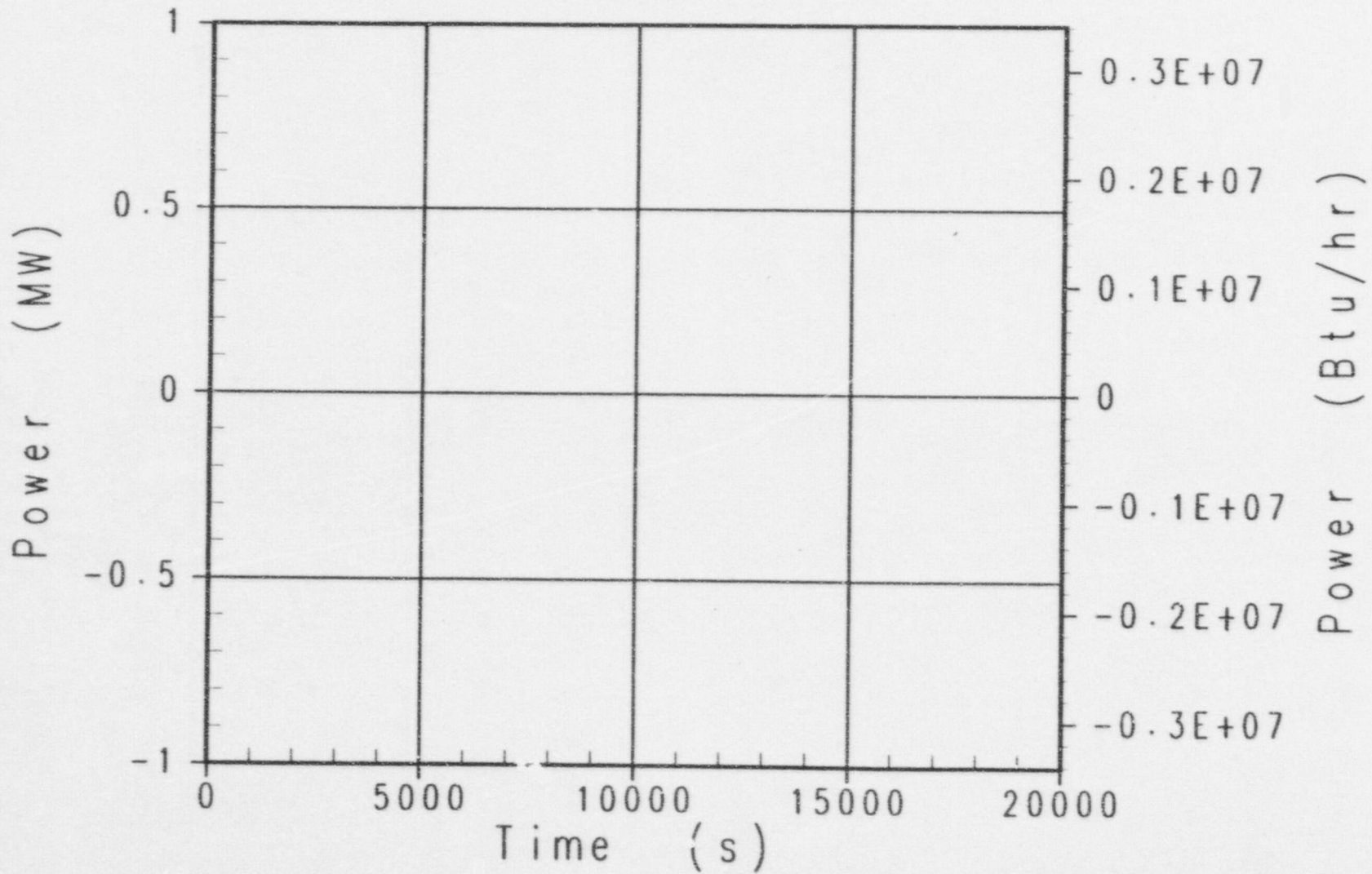

Case t1f AP600 Success Criteria MAAP4 Analysis
Peak Temperature in the Core

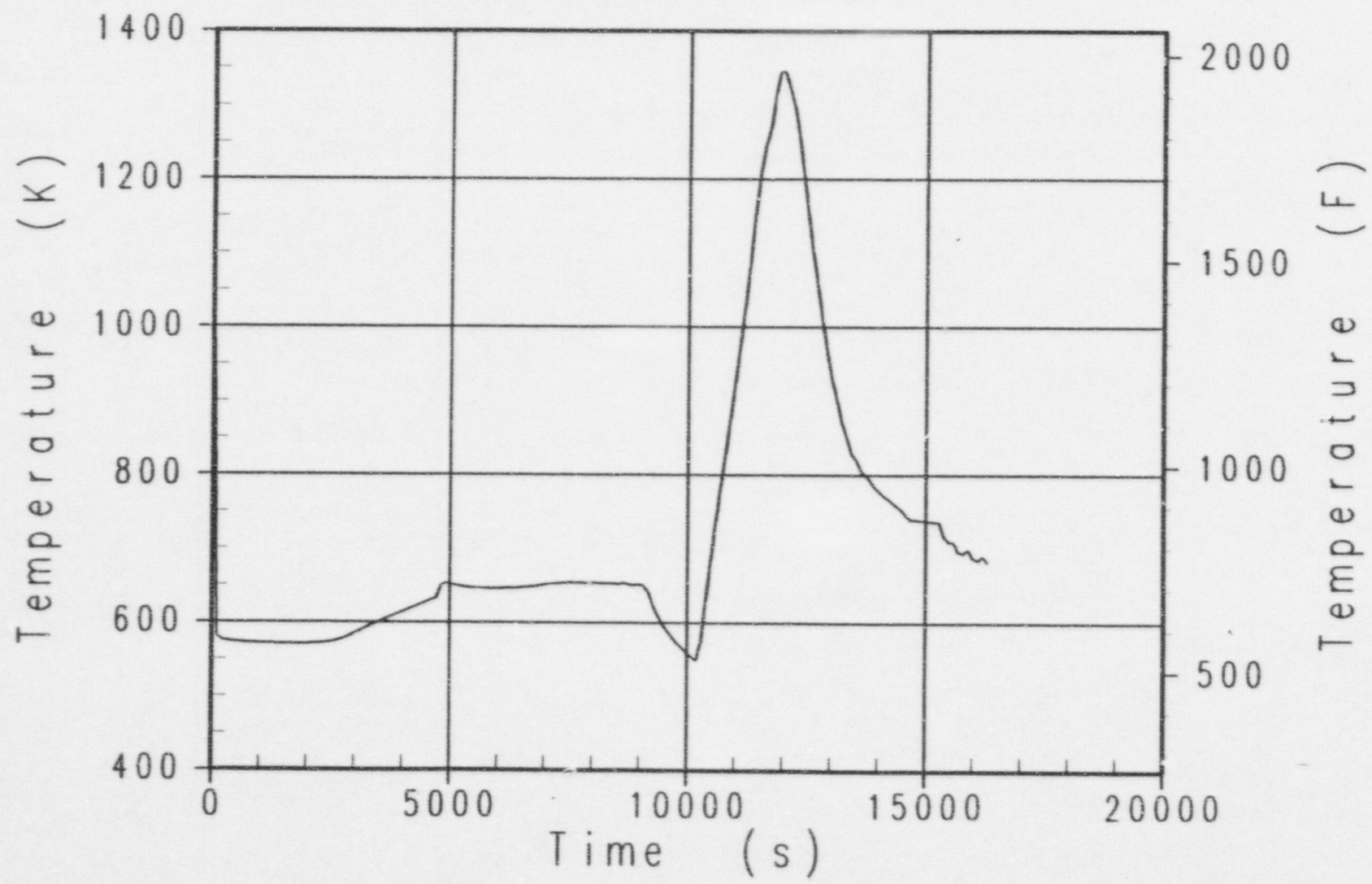

Case t1f AP600 Success Criteria MAAP4 Analysis
Cold Leg Water Temperature

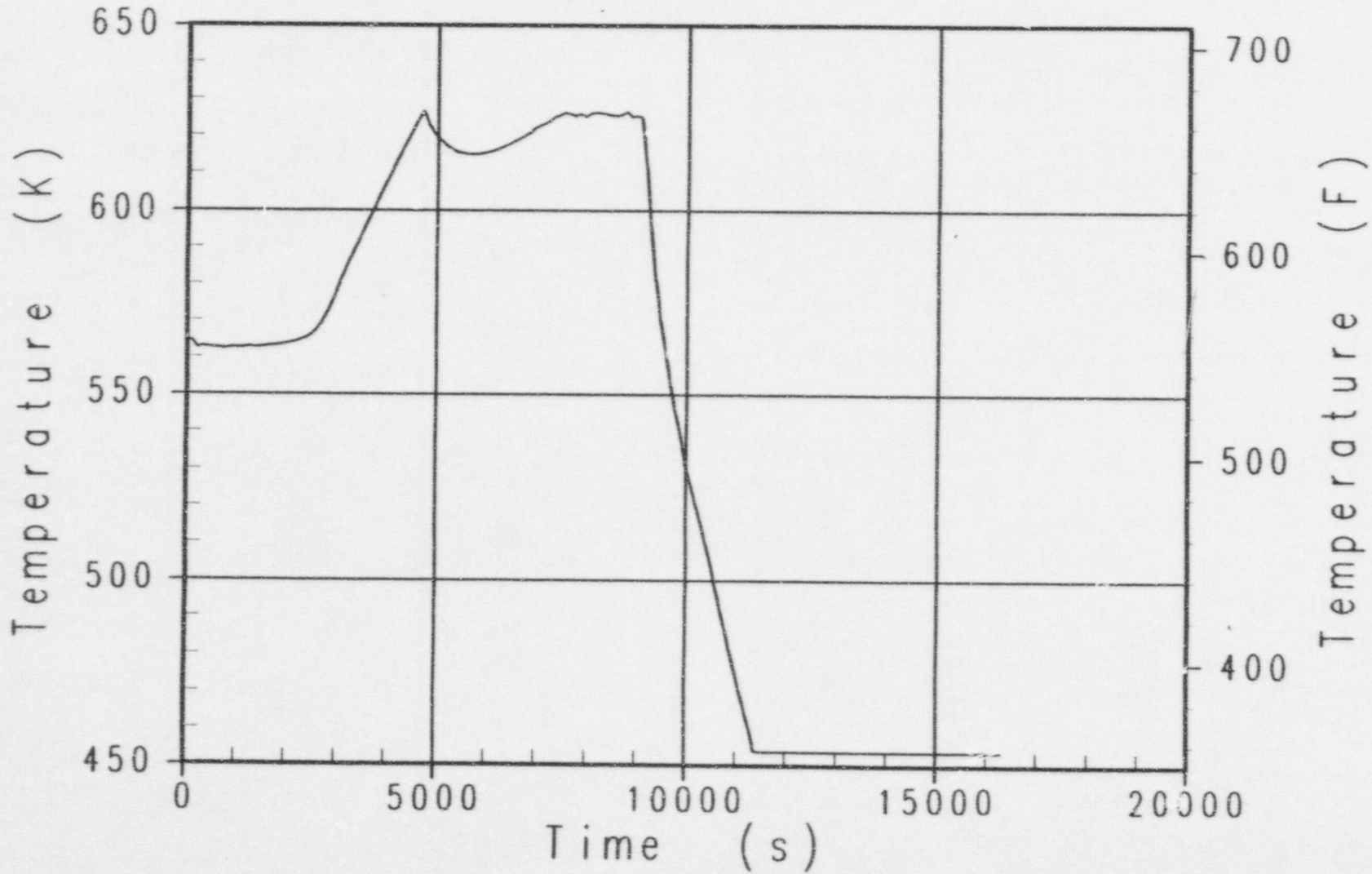

Case t1f AP600 Success Criteria MAAP4 Analysis
Core Water Temperature

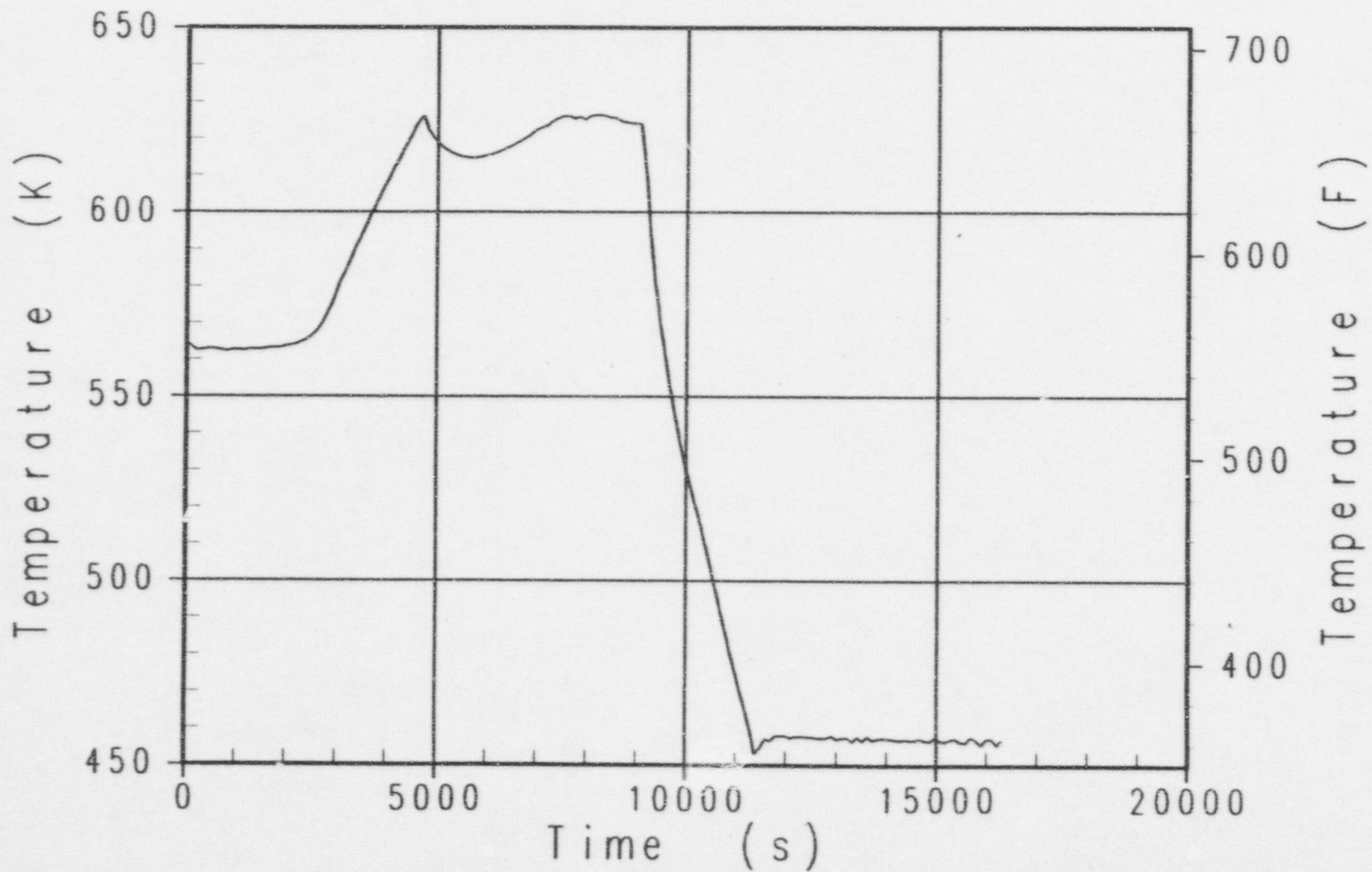

Case t1f AP600 Success Criteria MAAF4 Analysis
RPV Downcomer Water Temperature

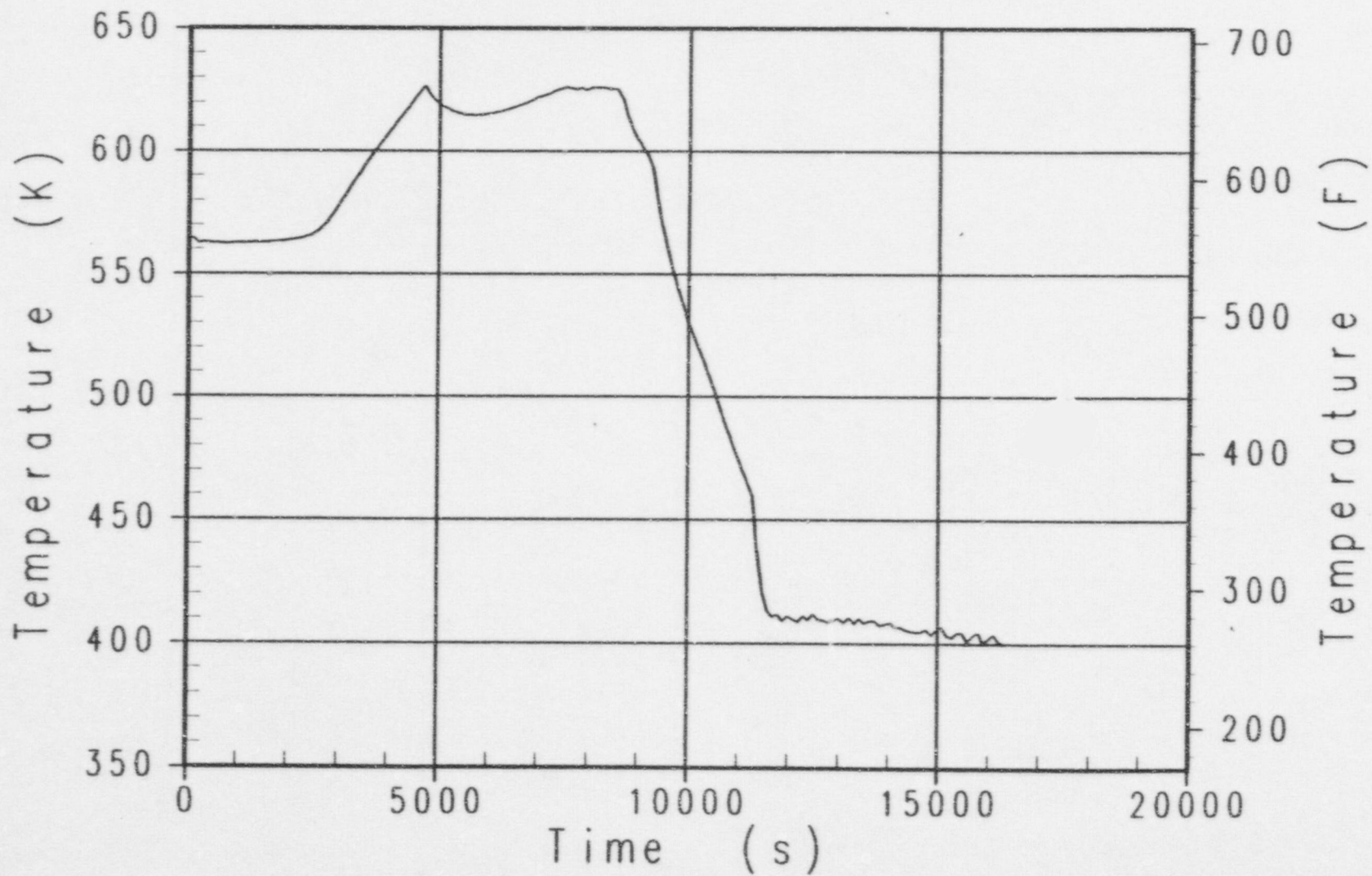

Case t1f AP600 Success Criteria MAAP4 Analysis
IRWST Water Temperature

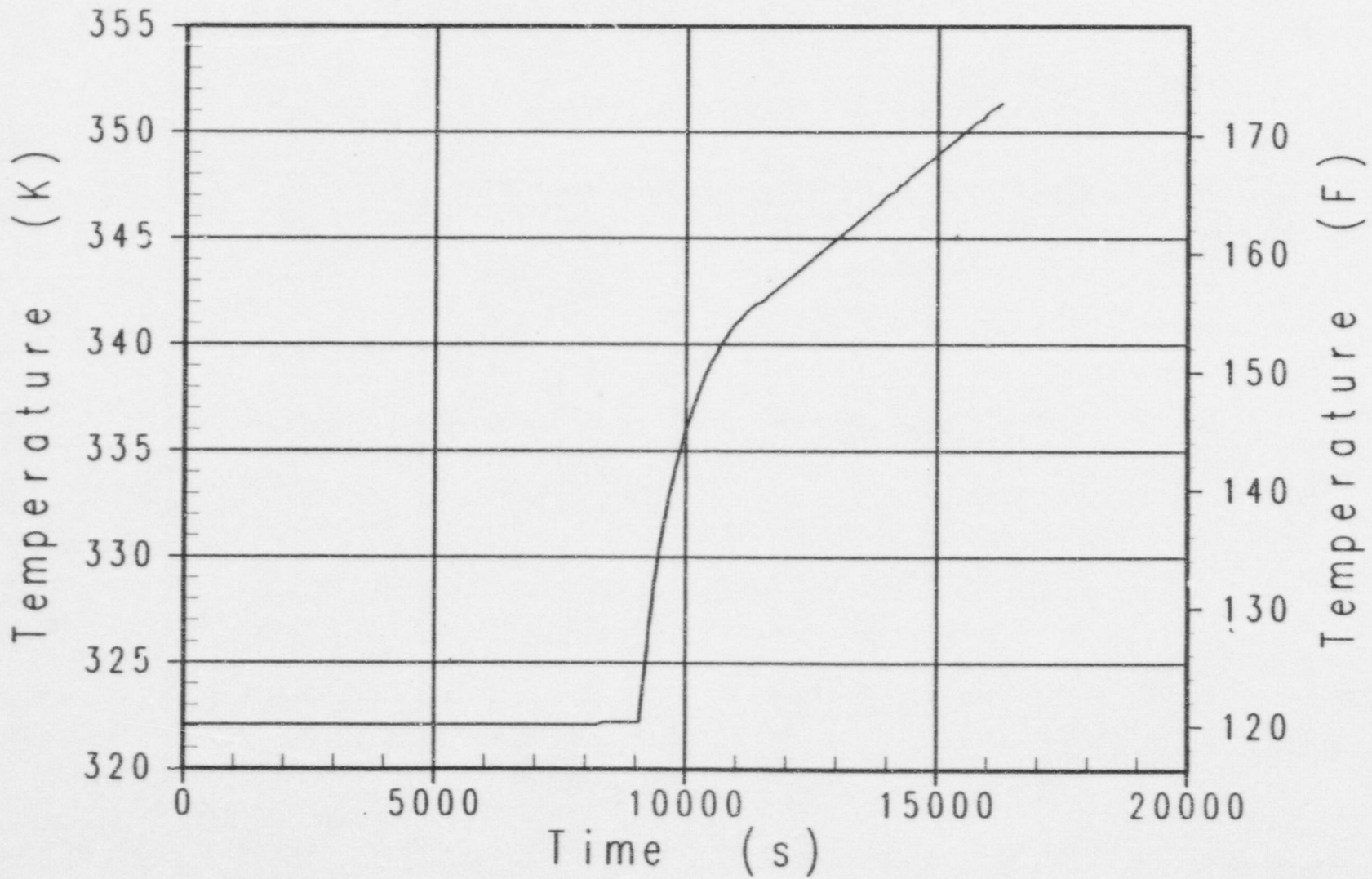

Case t1f AP600 Success Criteria MAAP4 Analysis
Accumulator and NRHR Injection Flowrate

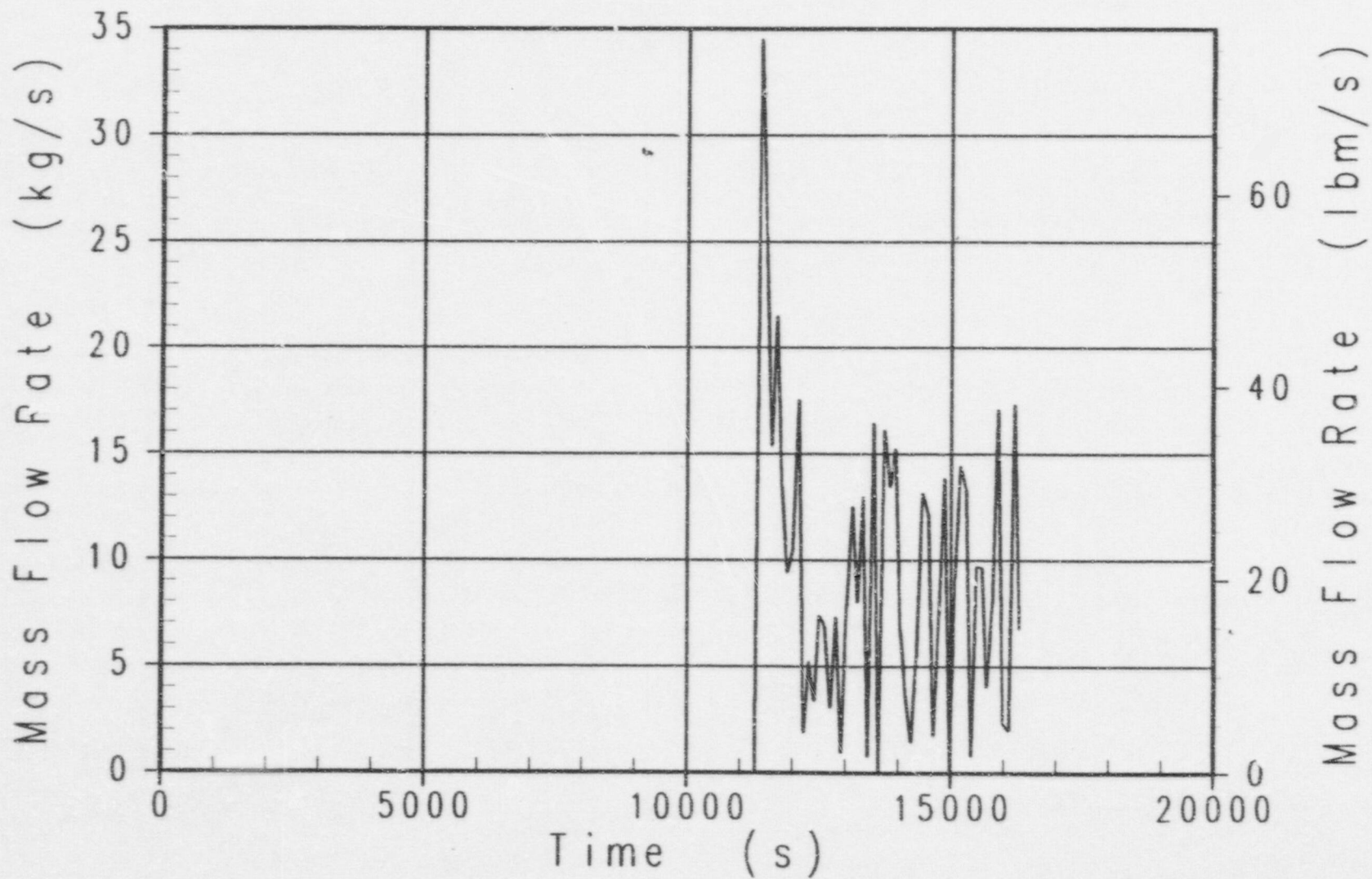

Case t1f AP600 Success Criteria MAAP4 Analysis
RCS Break Gas Flowrate

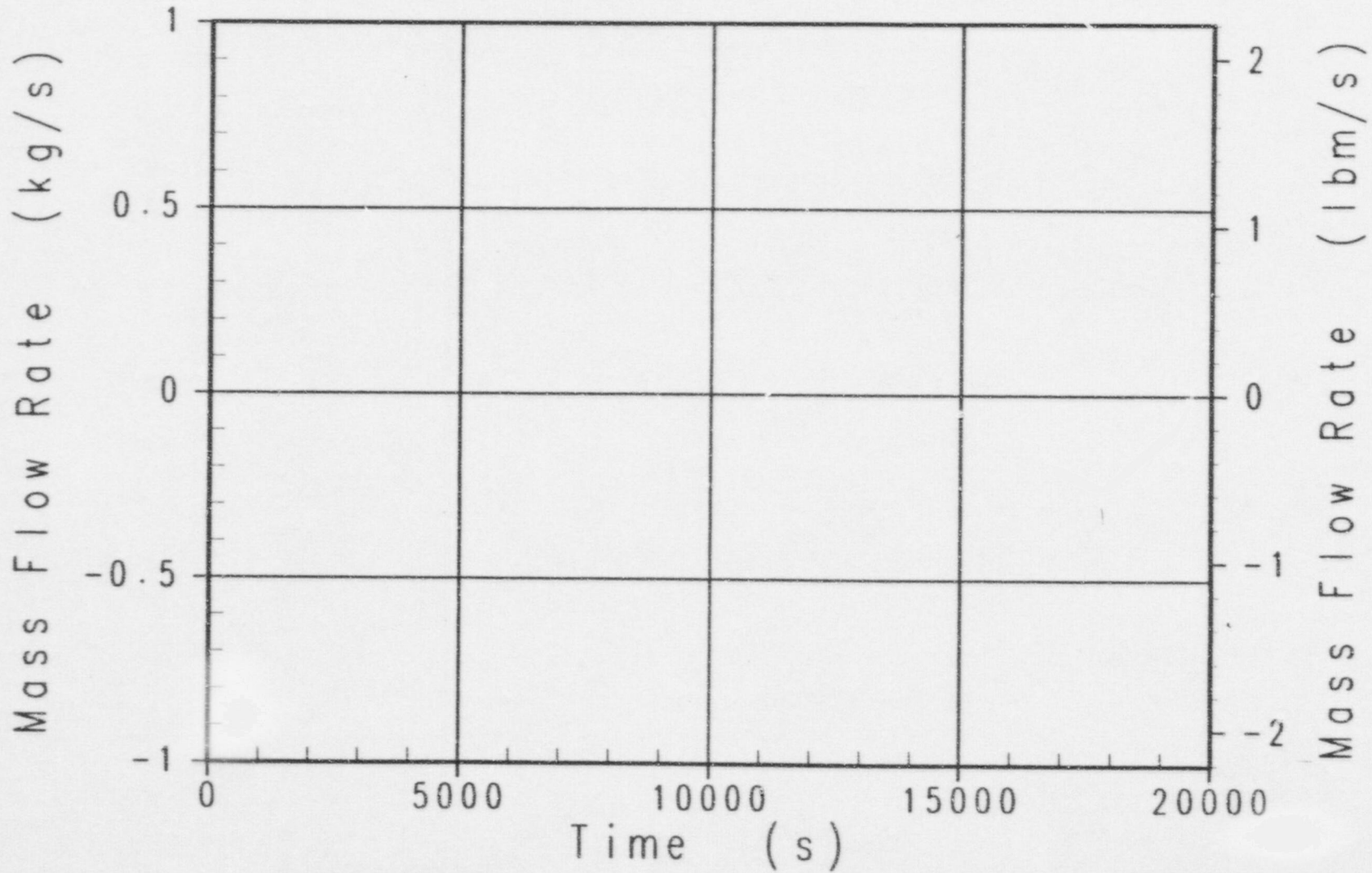

Case t1f AF600 Success Criteria MAAP4 Analysis
ADS Stage 4 Gas Flowrate

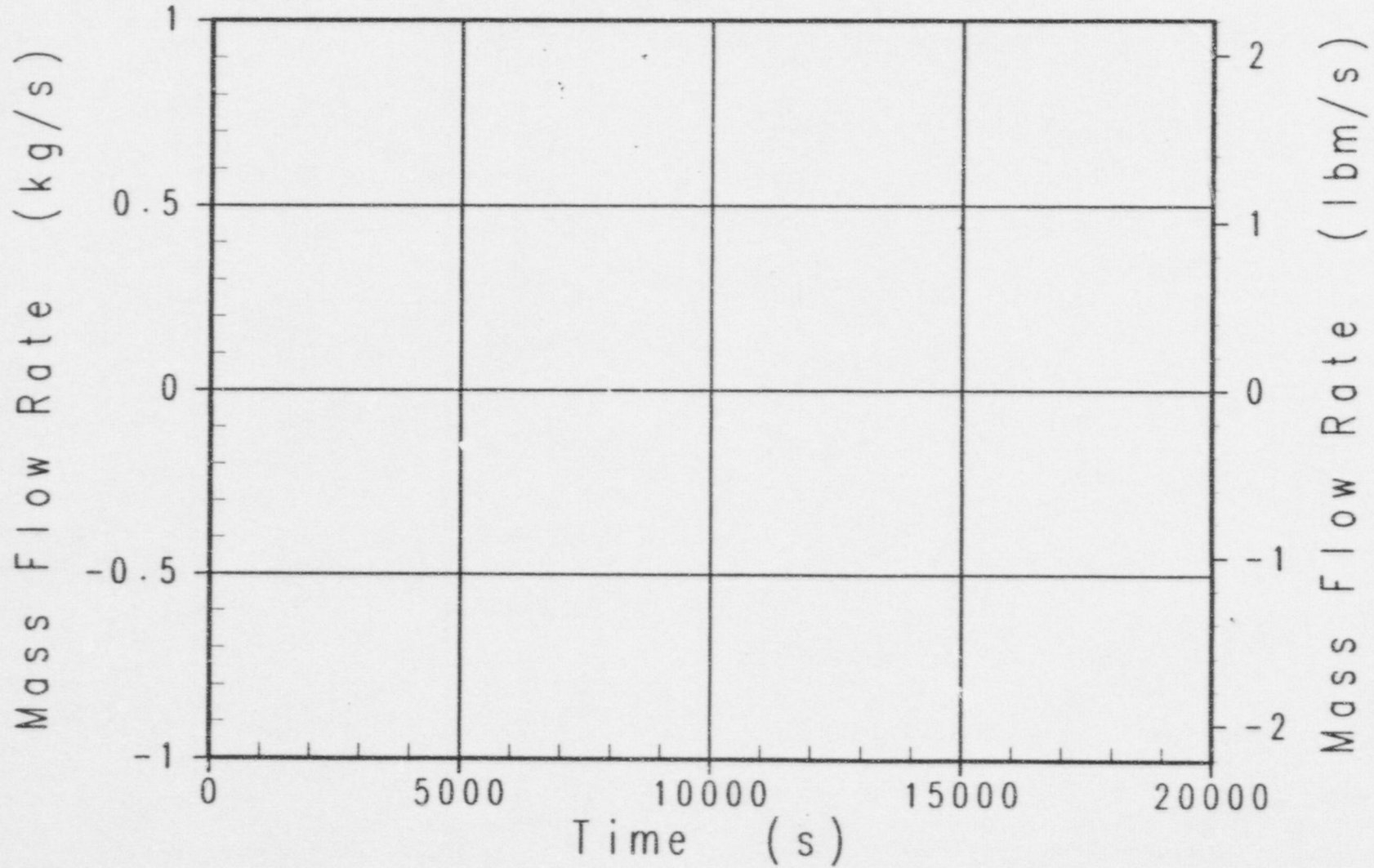

Case t1f AP600 Success Criteria MAAP4 Analysis
Safety Valve and ADS Stages 1-3 Gas Flowrate

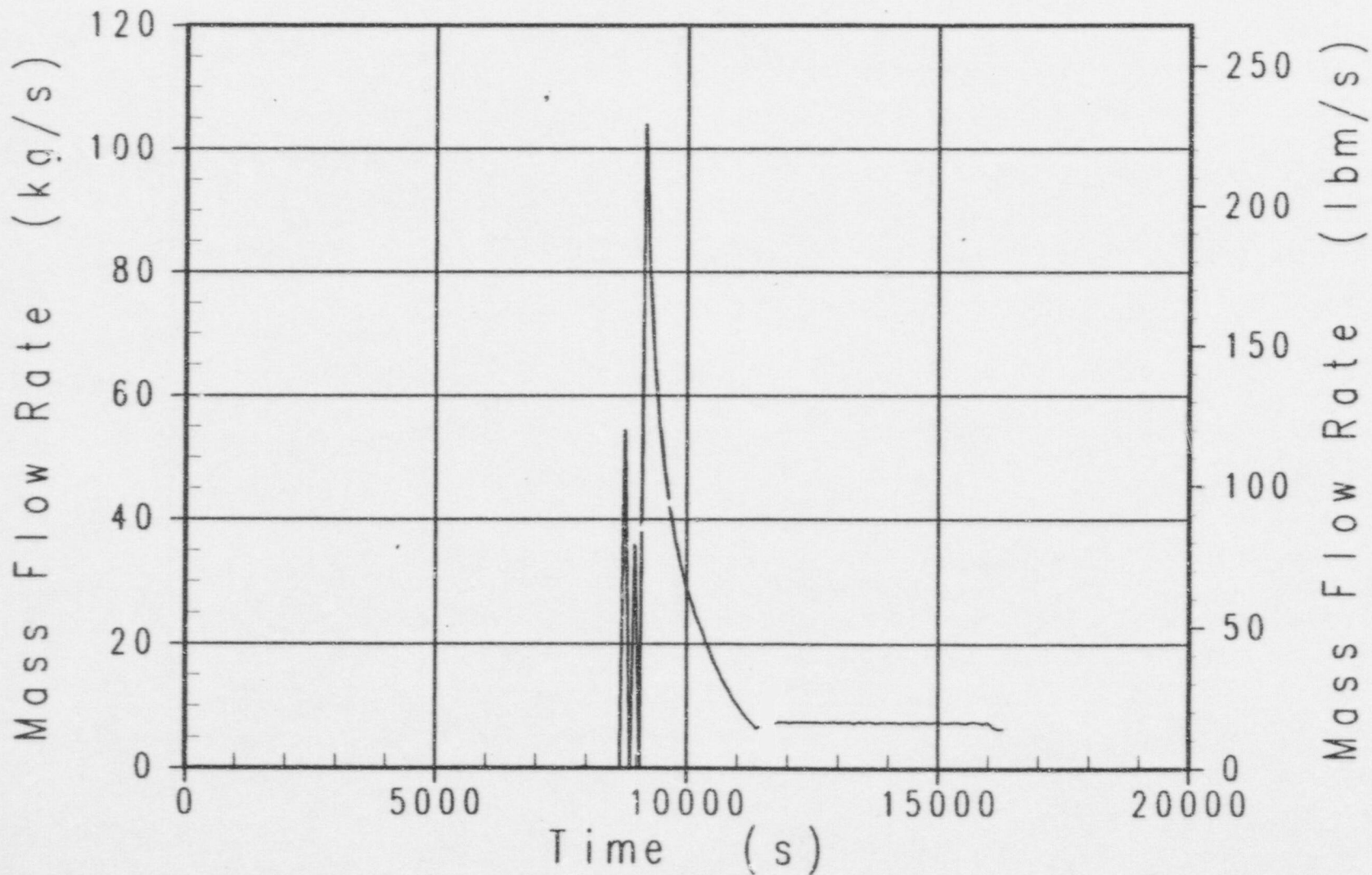

Case t1f AP600 Success Criteria MAAP4 Analysis
RCS Break Liquid Flowrate

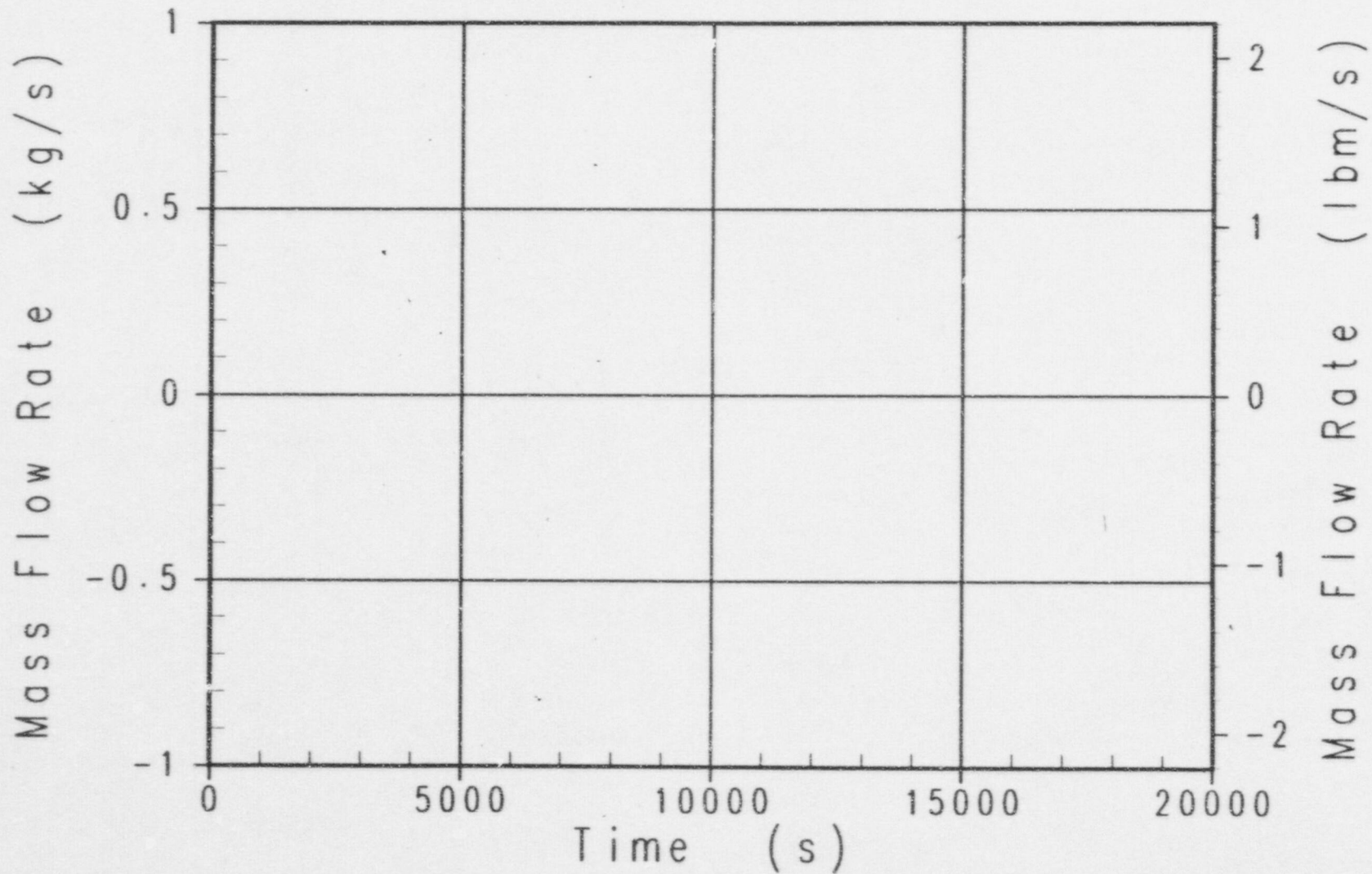

Case t1f AP600 Success Criteria MAAP4 Analysis
ADS Stage 4 Liquid Flowrate

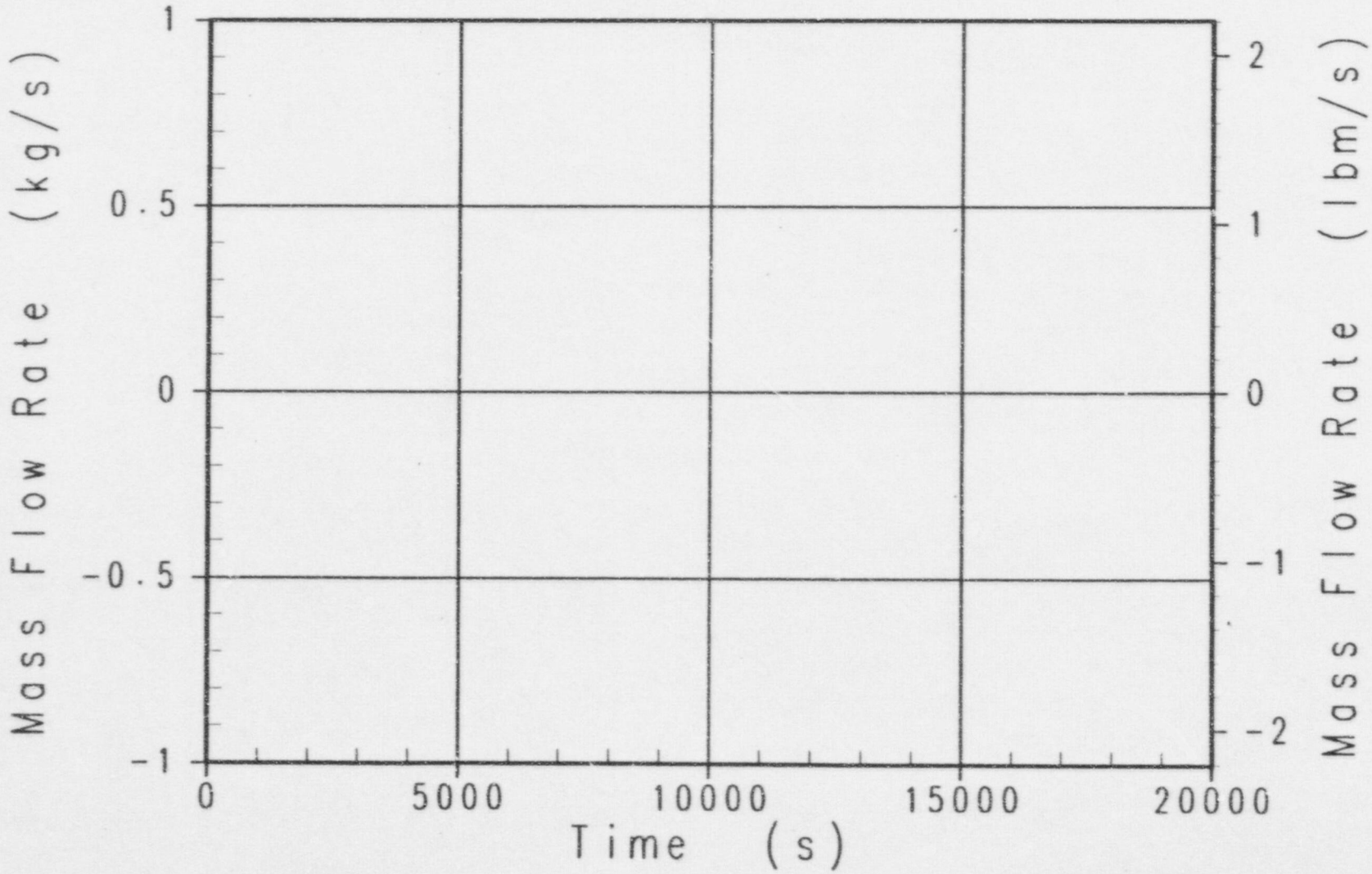

Case t1f AP600 Success Criteria MAAP4 Analysis
IRWST Injection Flowrate (neg. means into RCS)

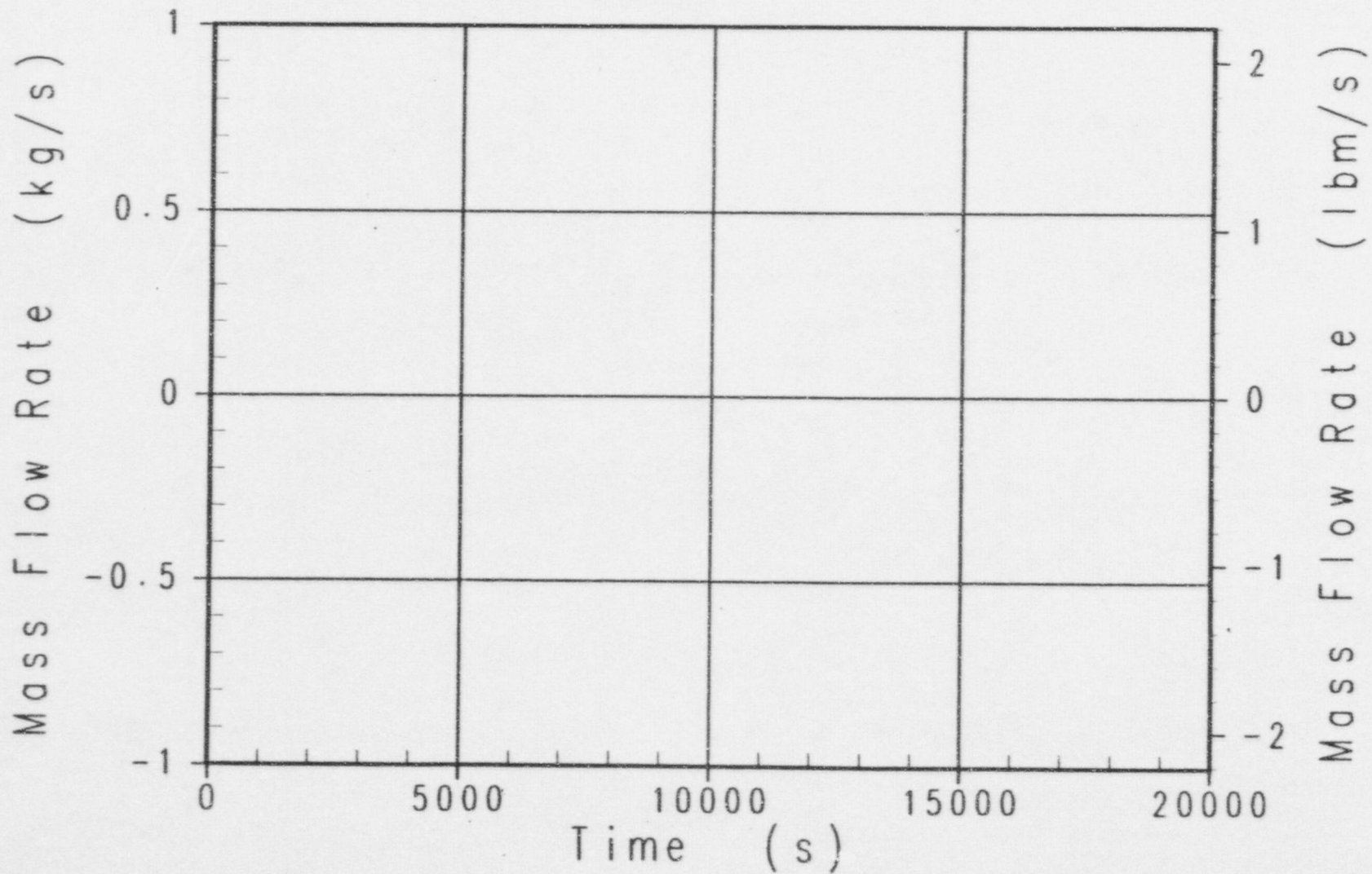

Case t1f AP600 Success Criteria MAAP4 Analysis
CMT-1 Injection Flowrate

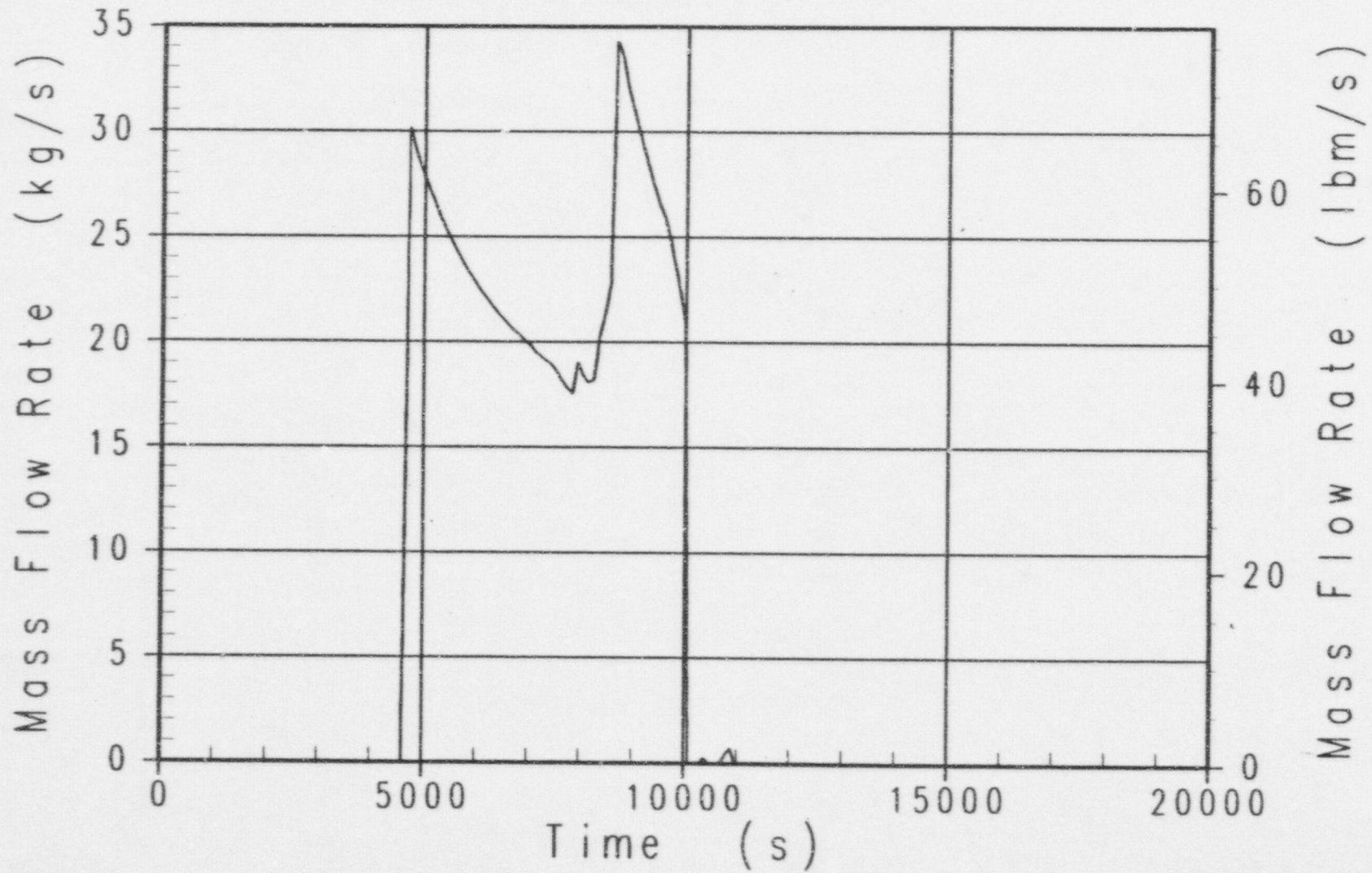

Case 11f AP600 Success Criteria MAAP4 Analysis
Safety Valve and ADS Stages 1-3 Liquid Flowrate

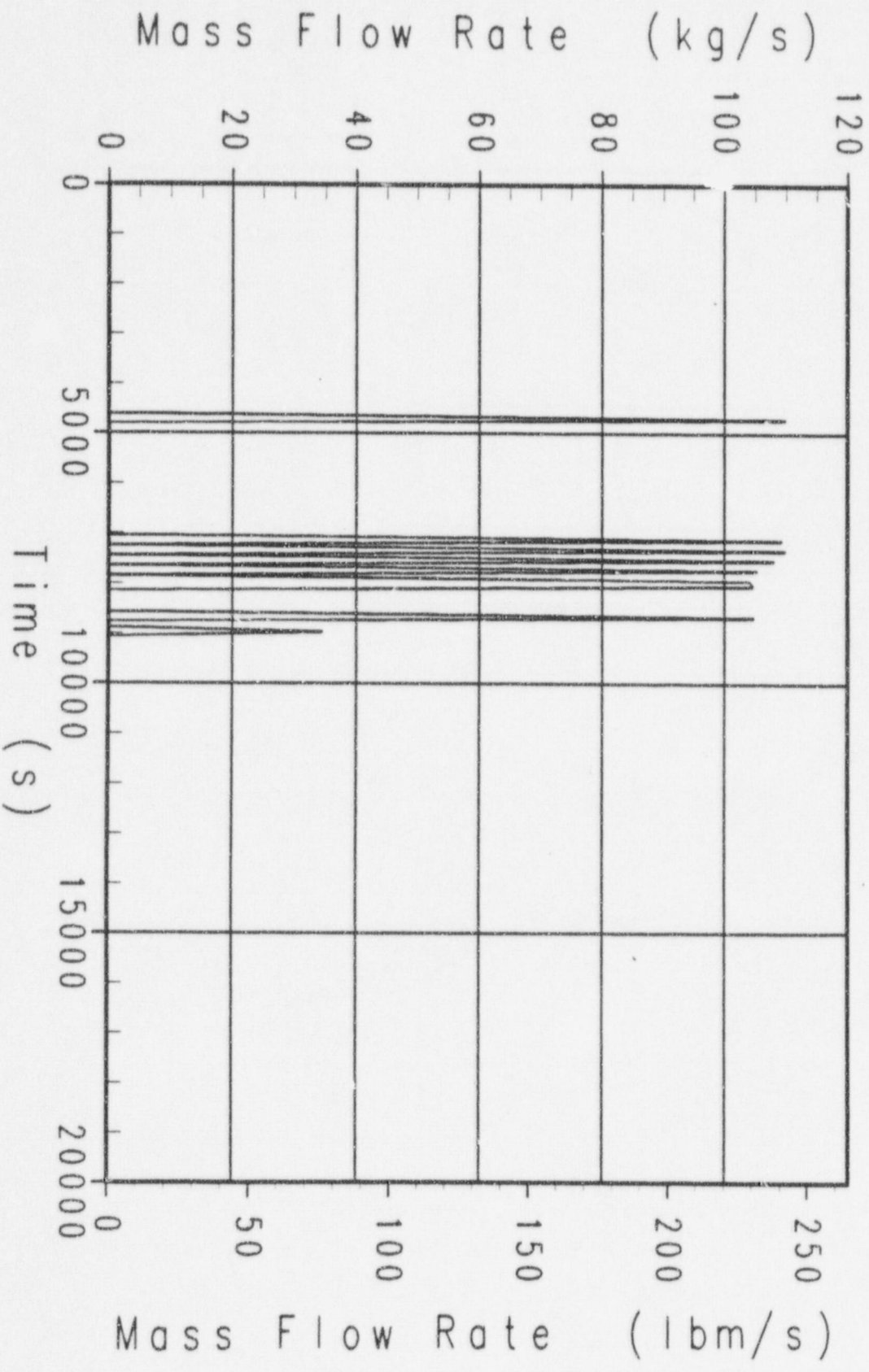

Case t1f AP600 Success Criteria MAAP4 Analysis
CMT-1 Water Level



Case t1f AP600 Success Criteria MAAP4 Analysis
Pressurizer Water Level (From Pzr Bottom)

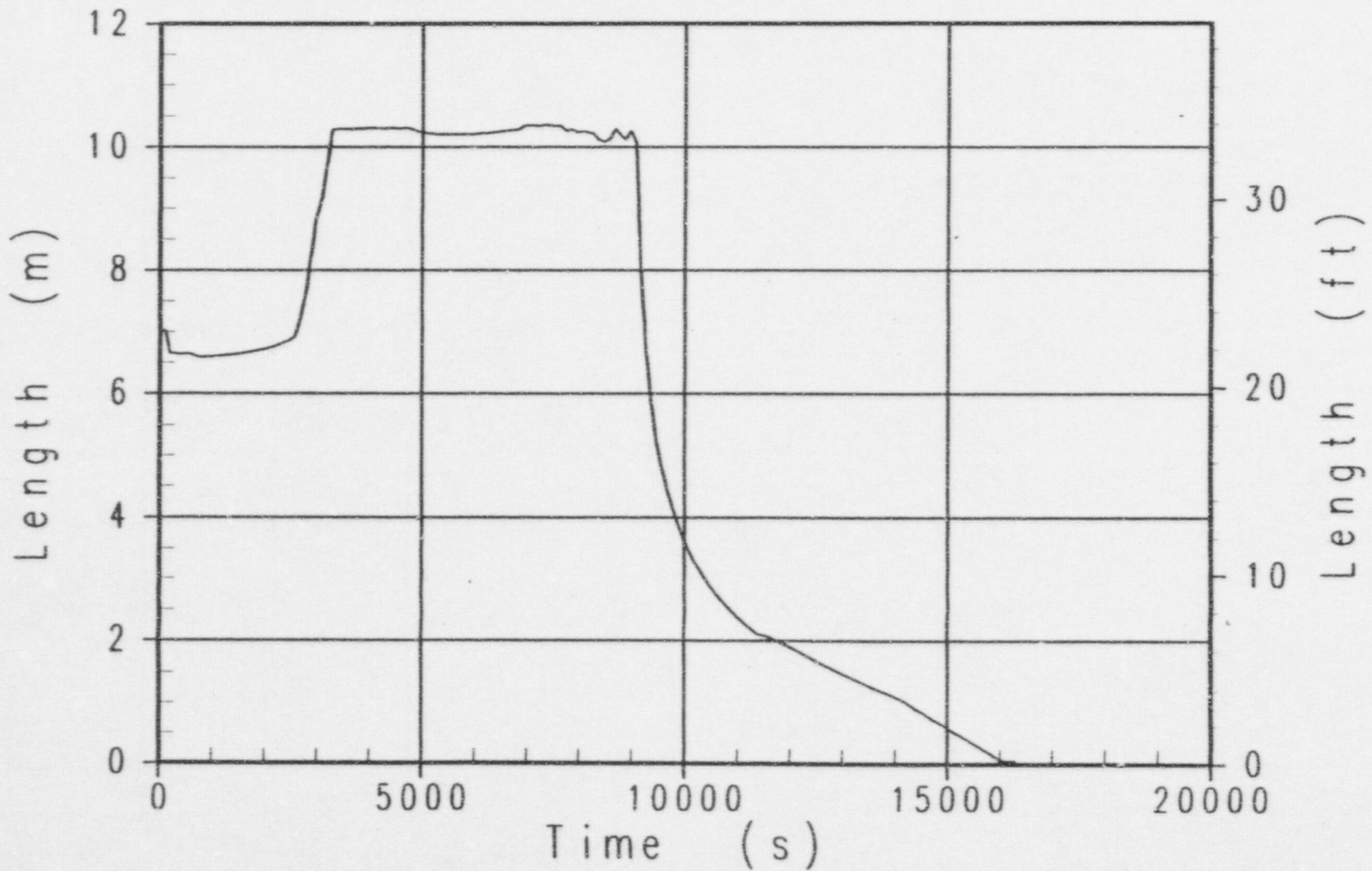

Case t2a AP600 Success Criteria MAAP4 Analysis
Broken Loop Steam Generator Pressure

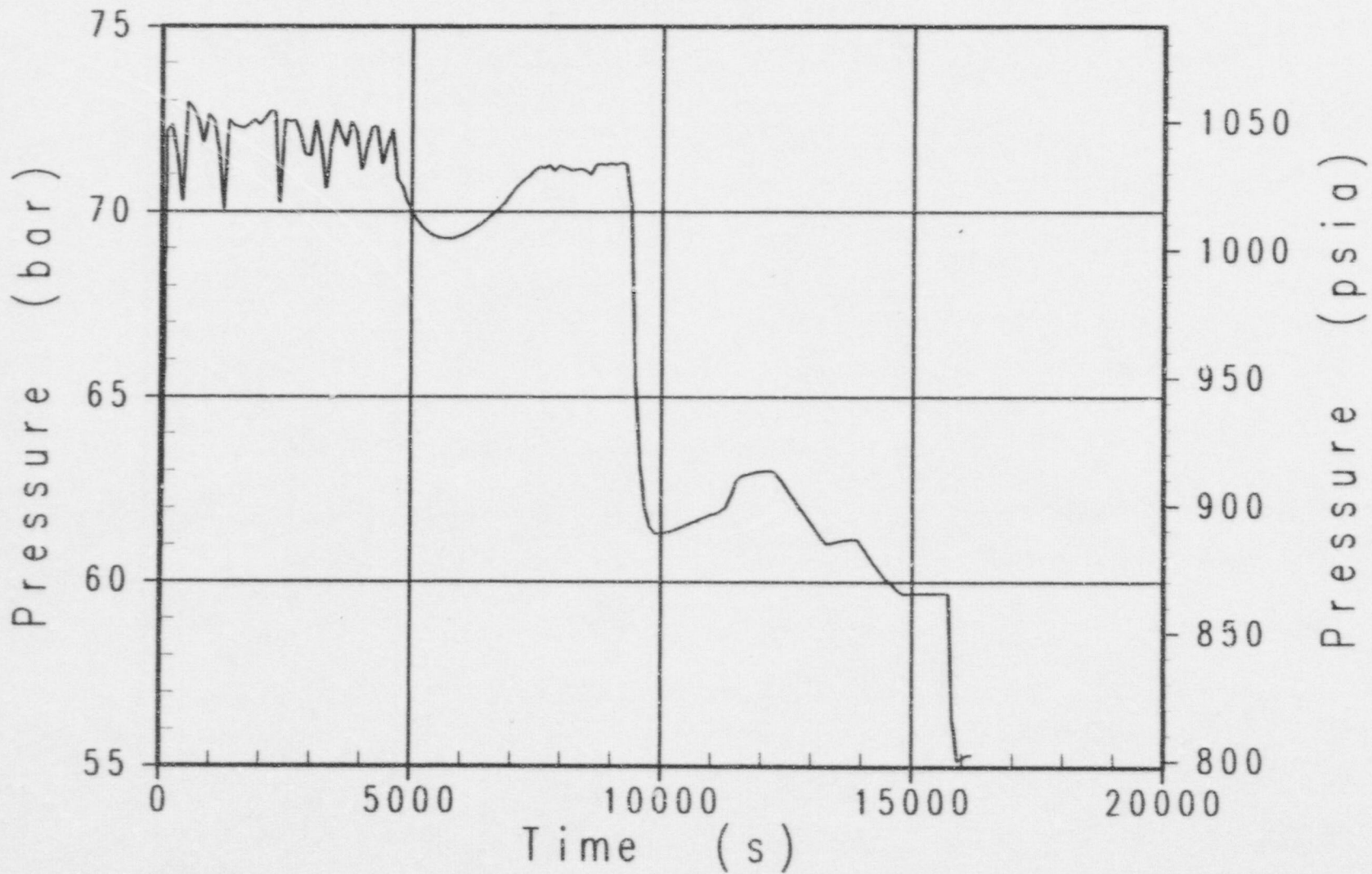

Case t2a AP600 Success Criteria MAAP4 Analysis
Primary System Pressure

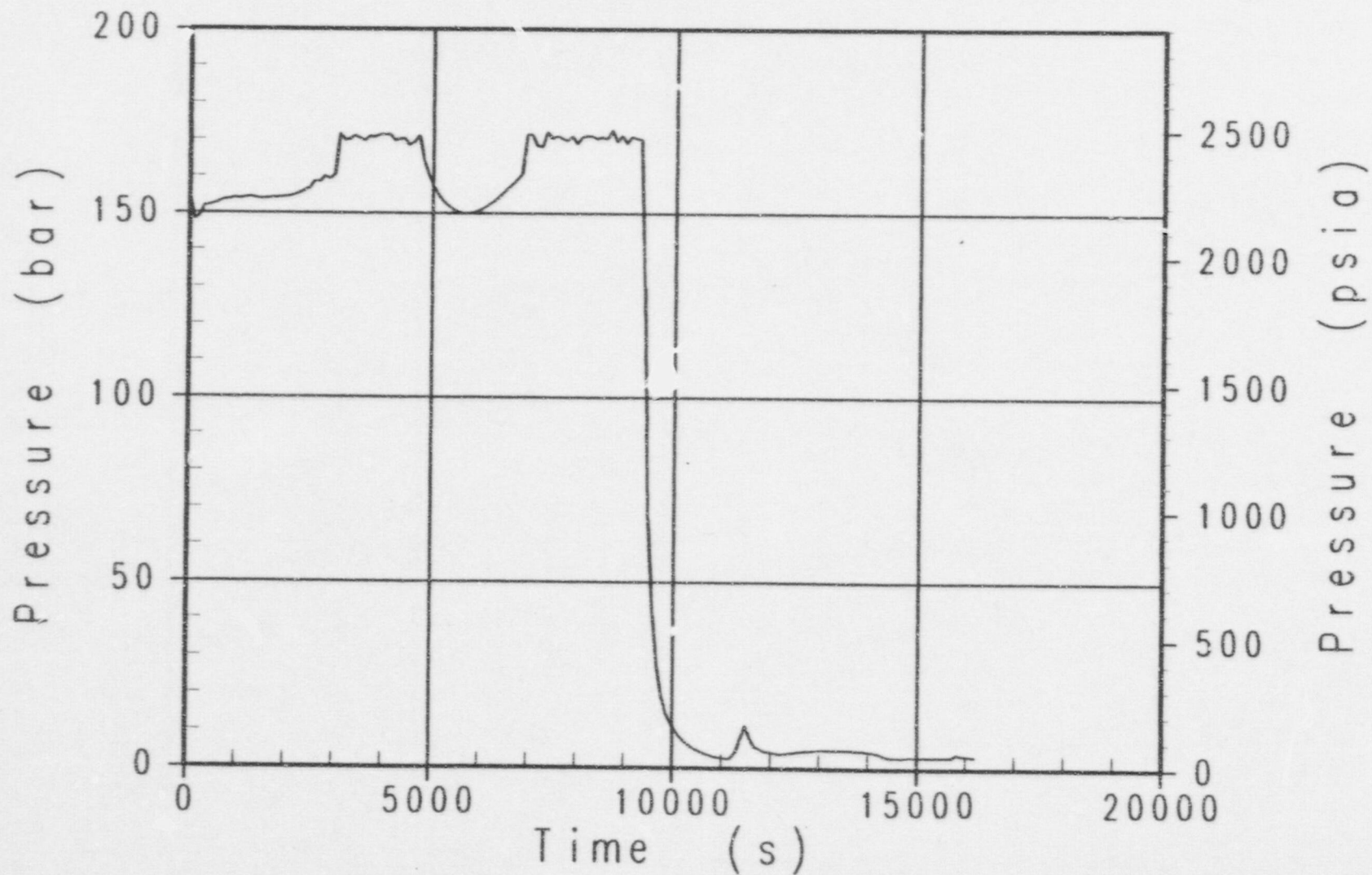

Case t2a AP600 Success Criteria MAAP4 Analysis
Containment Pressure

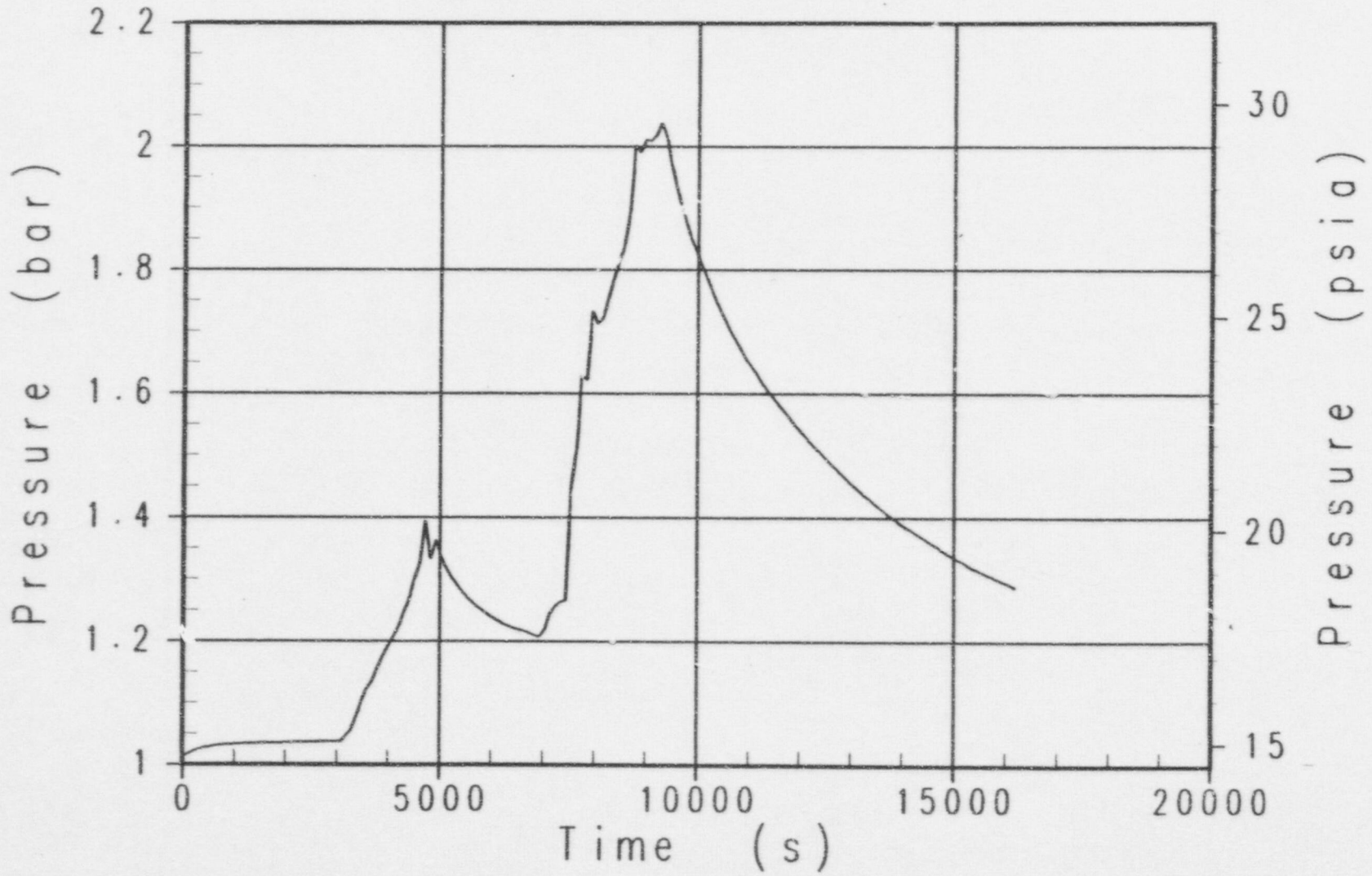

Case t2a AP600 Success Criteria MAAP4 Analysis
Unbroken Loop Steam Generator Pressure

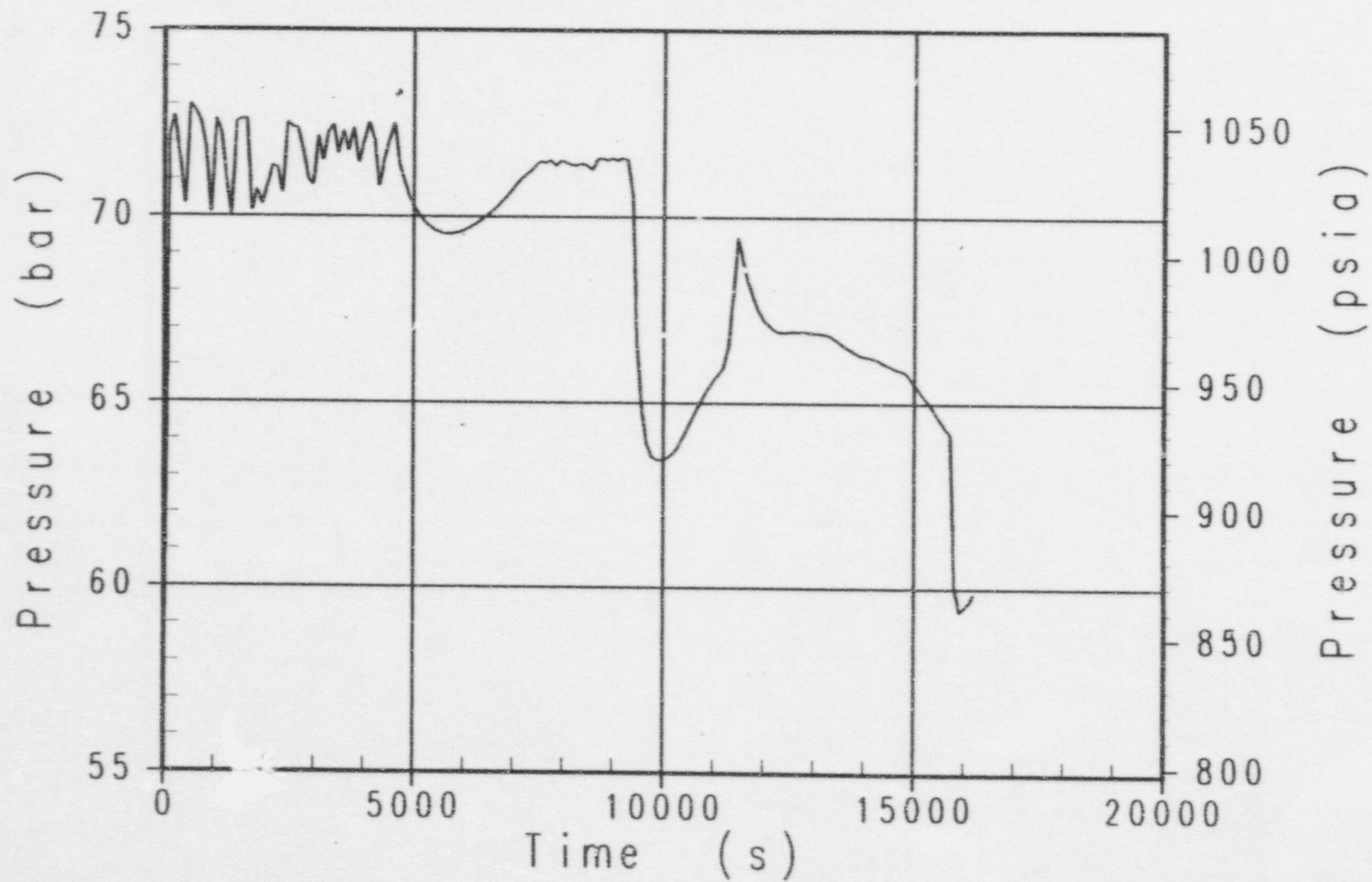

Case t2a APC00 Success Criteria MAAP4 Analysis
Decay Power

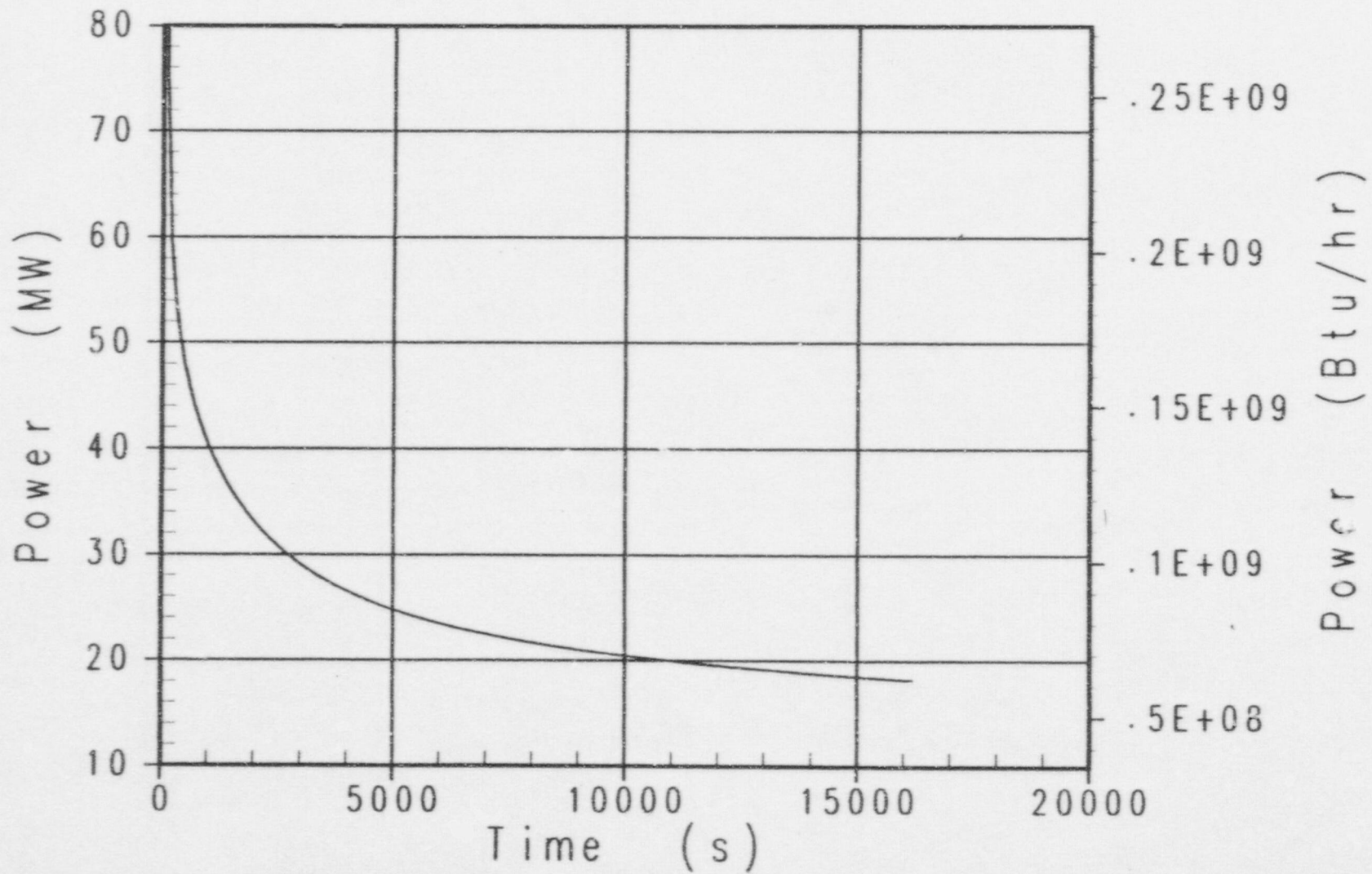

Case t2a AP600 Success Criteria MAAP4 Analysis
PRHR Heat Removal Rate

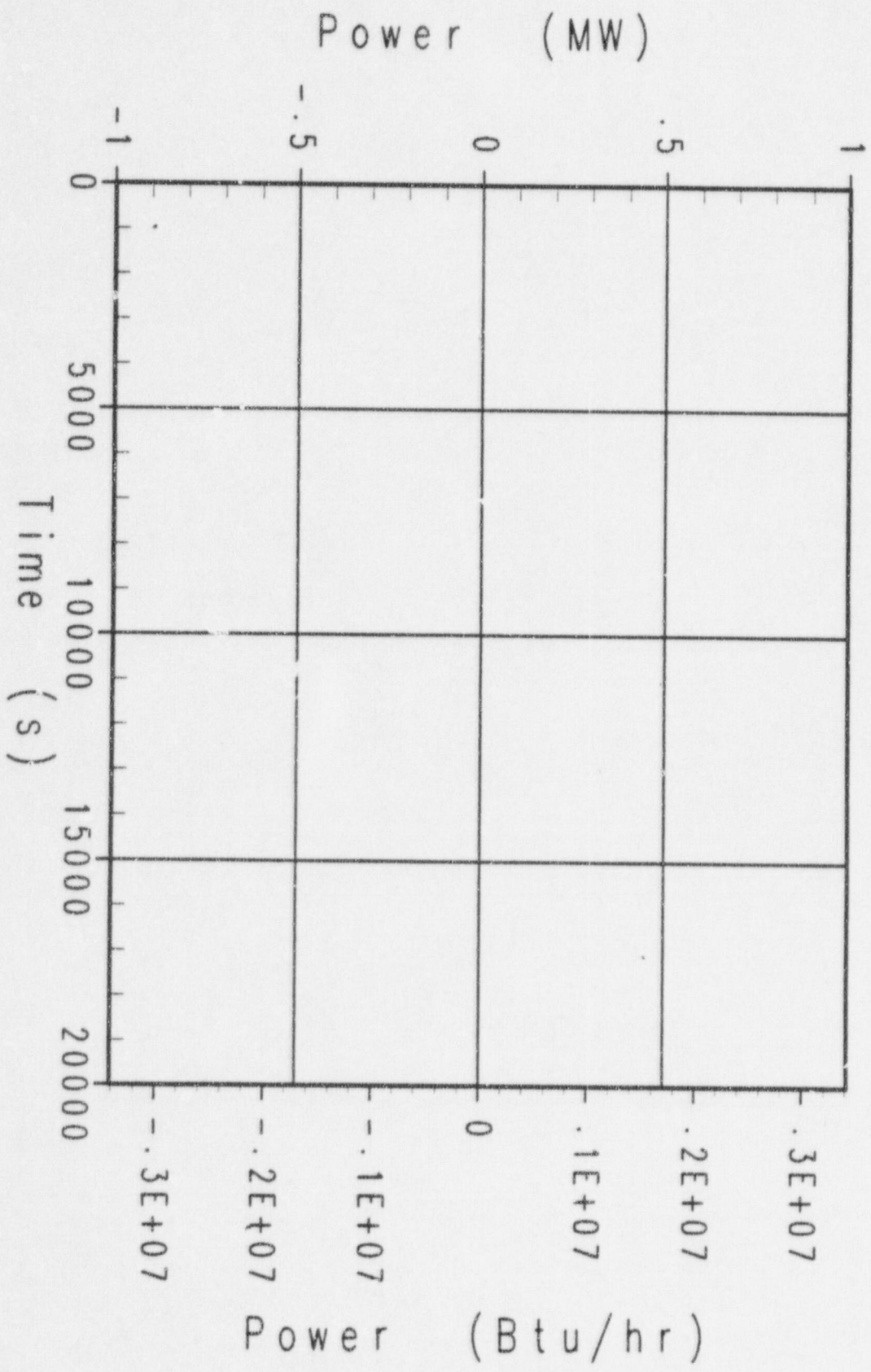

Case t2a AP600 Success Criteria MAAP4 Analysis
Peak Temperature in the Core

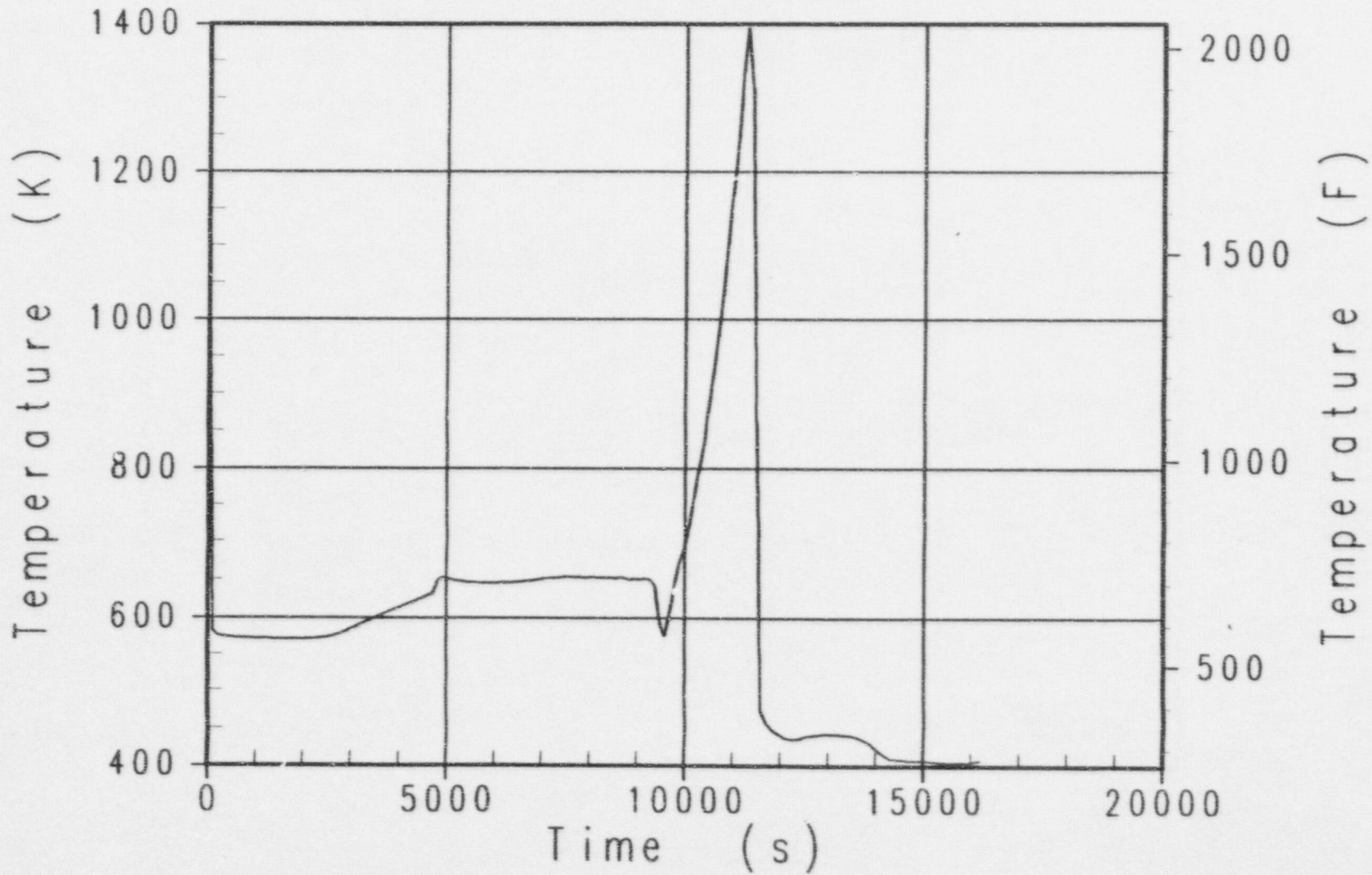

Case t2a AP600 Success Criteria MAAP4 Analysis
Cold Leg Water Temperature

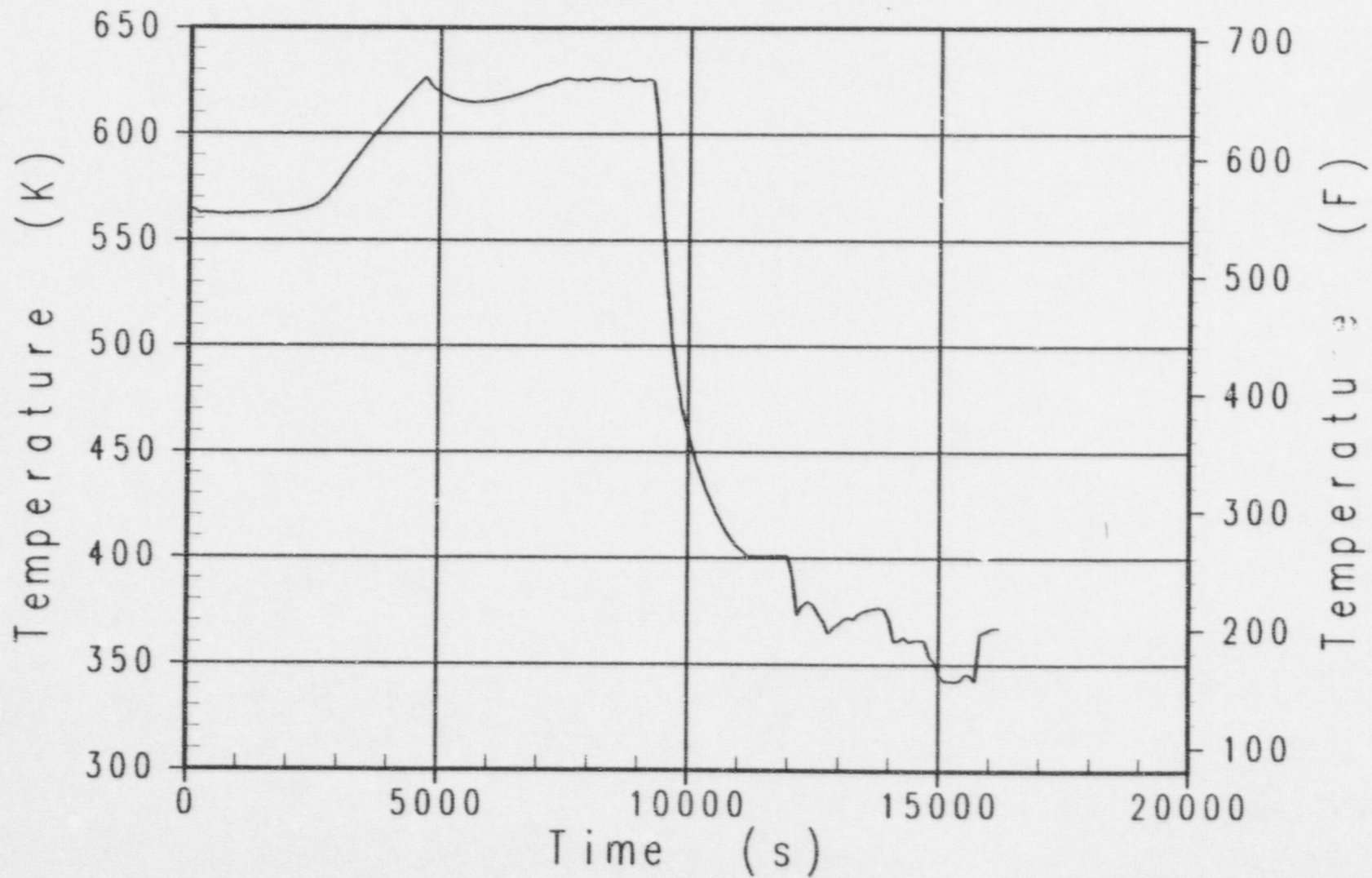

Case t2a AP600 Success Criteria MAAP4 Analysis
Core Water Temperature

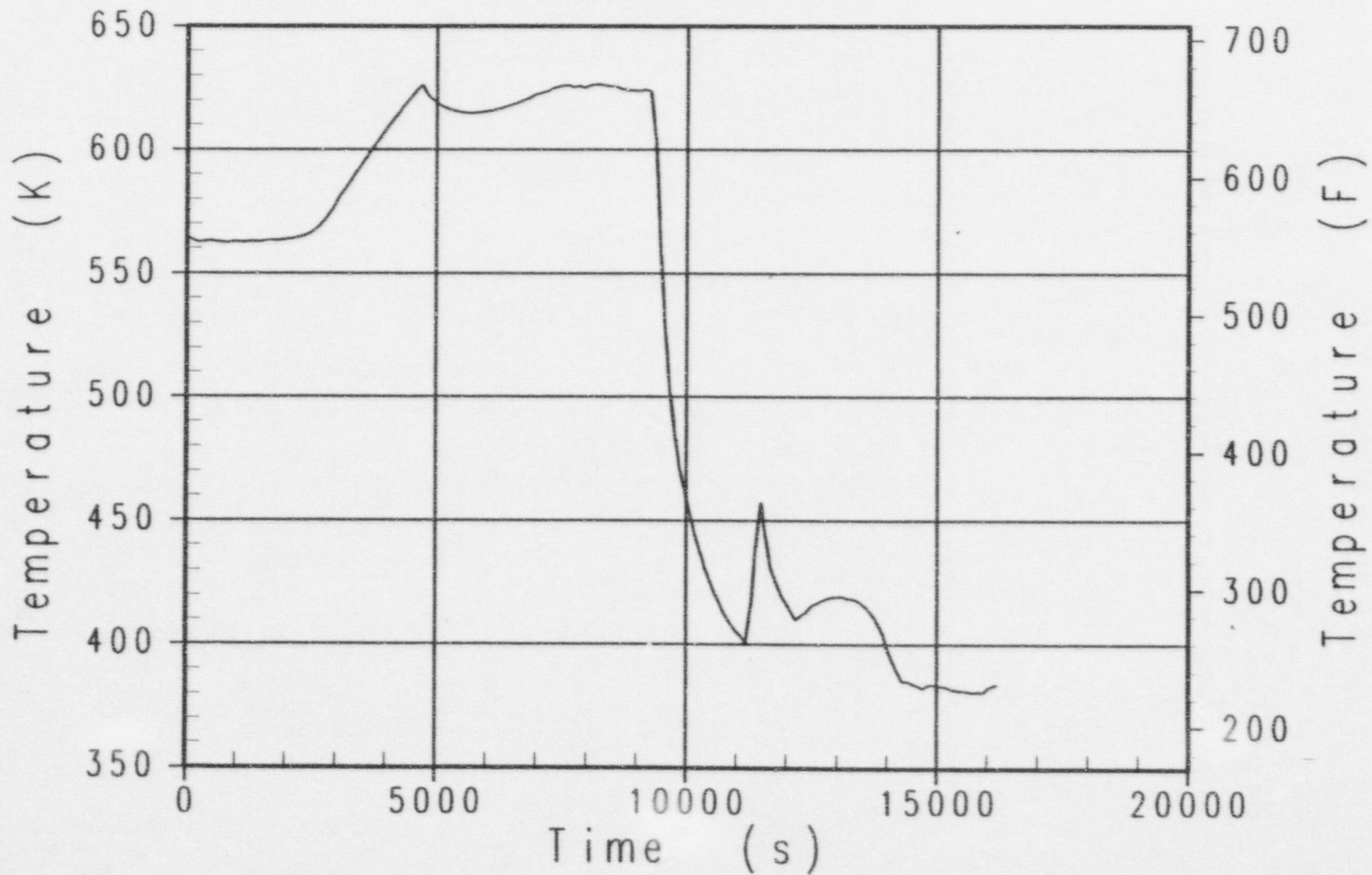

Case t2a AP600 Success Criteria MAAp4 Analysis
RPV Downcomer Water Temperature

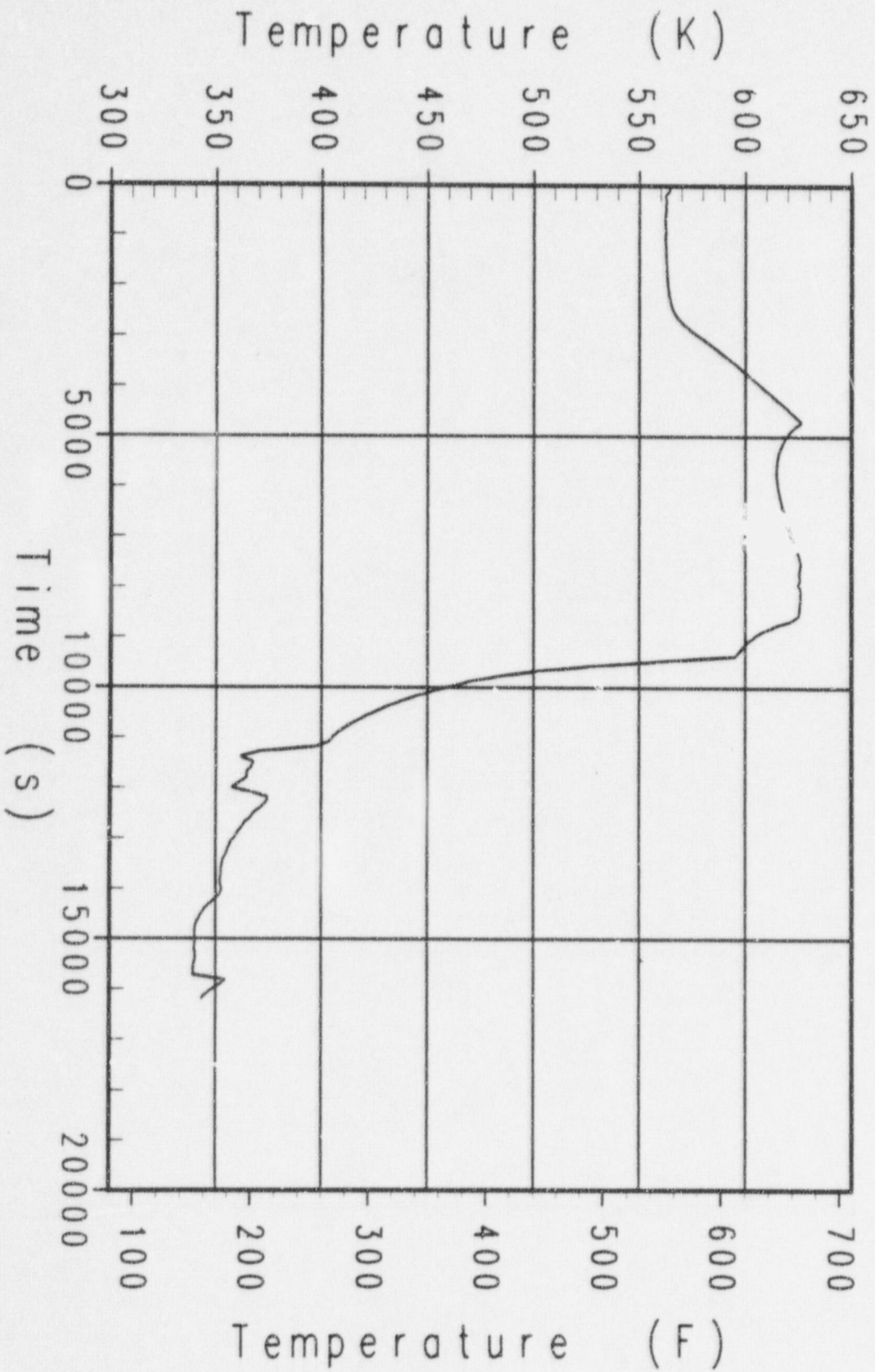

Case t2a AP600 Success Criteria MAAP4 Analysis
IRWST Water Temperature

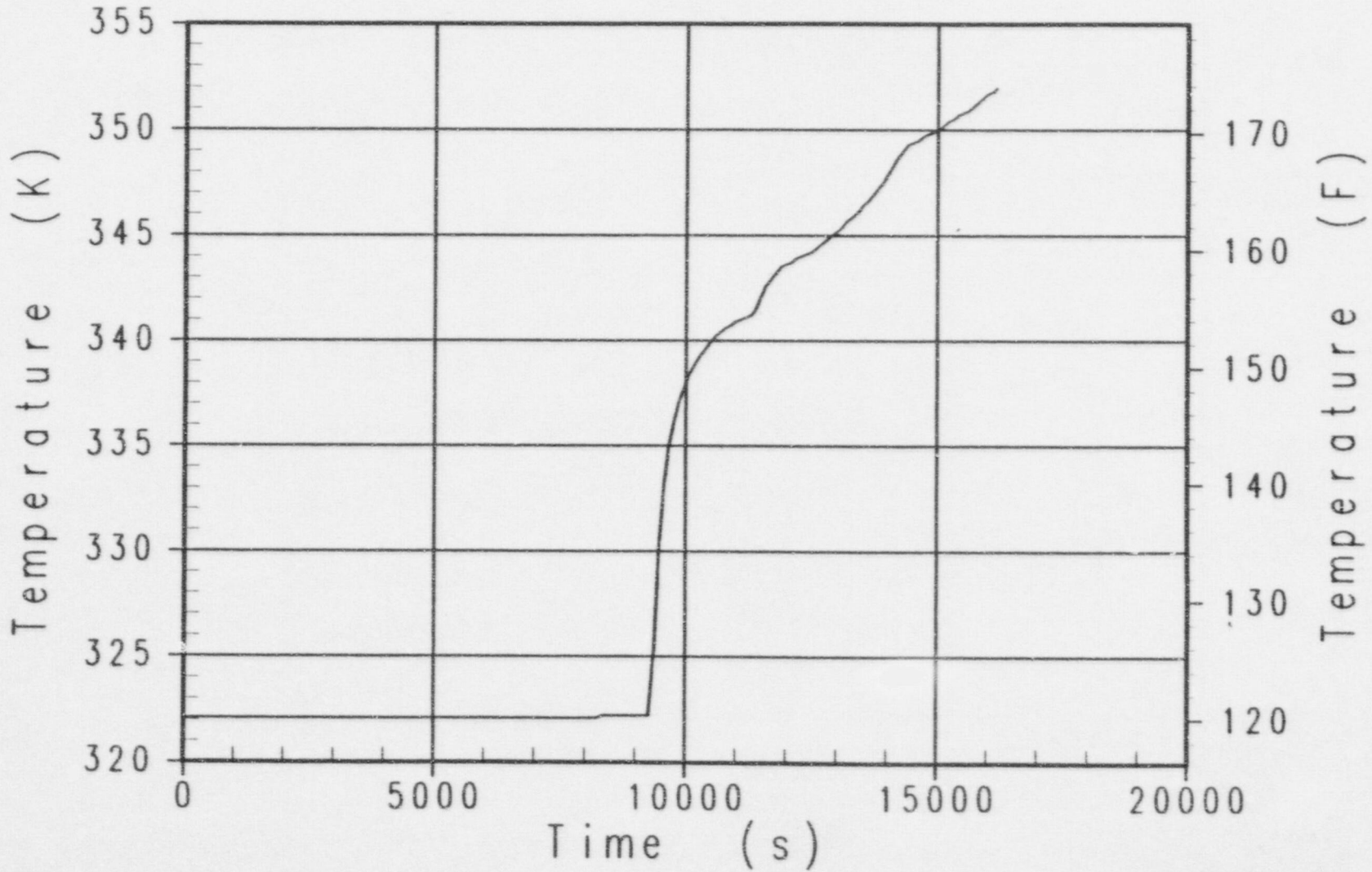

Case t2a AP600 Success Criteria MAAP4 Analysis
Accumulator and NRHR Injection Flowrate

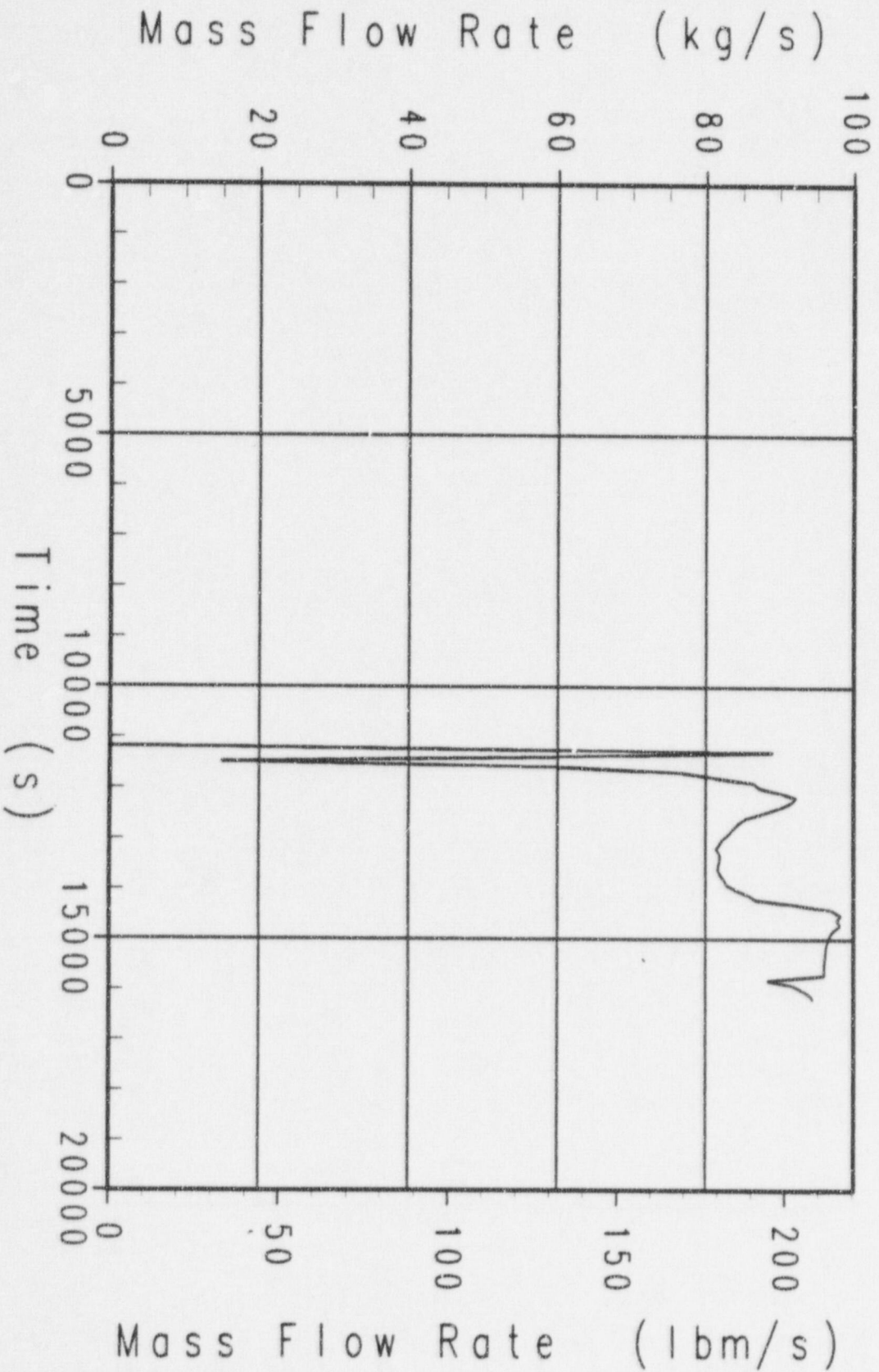

Case t2a AP600 Success Criteria MAAP4 Analysis
RCS Break Gas Flowrate

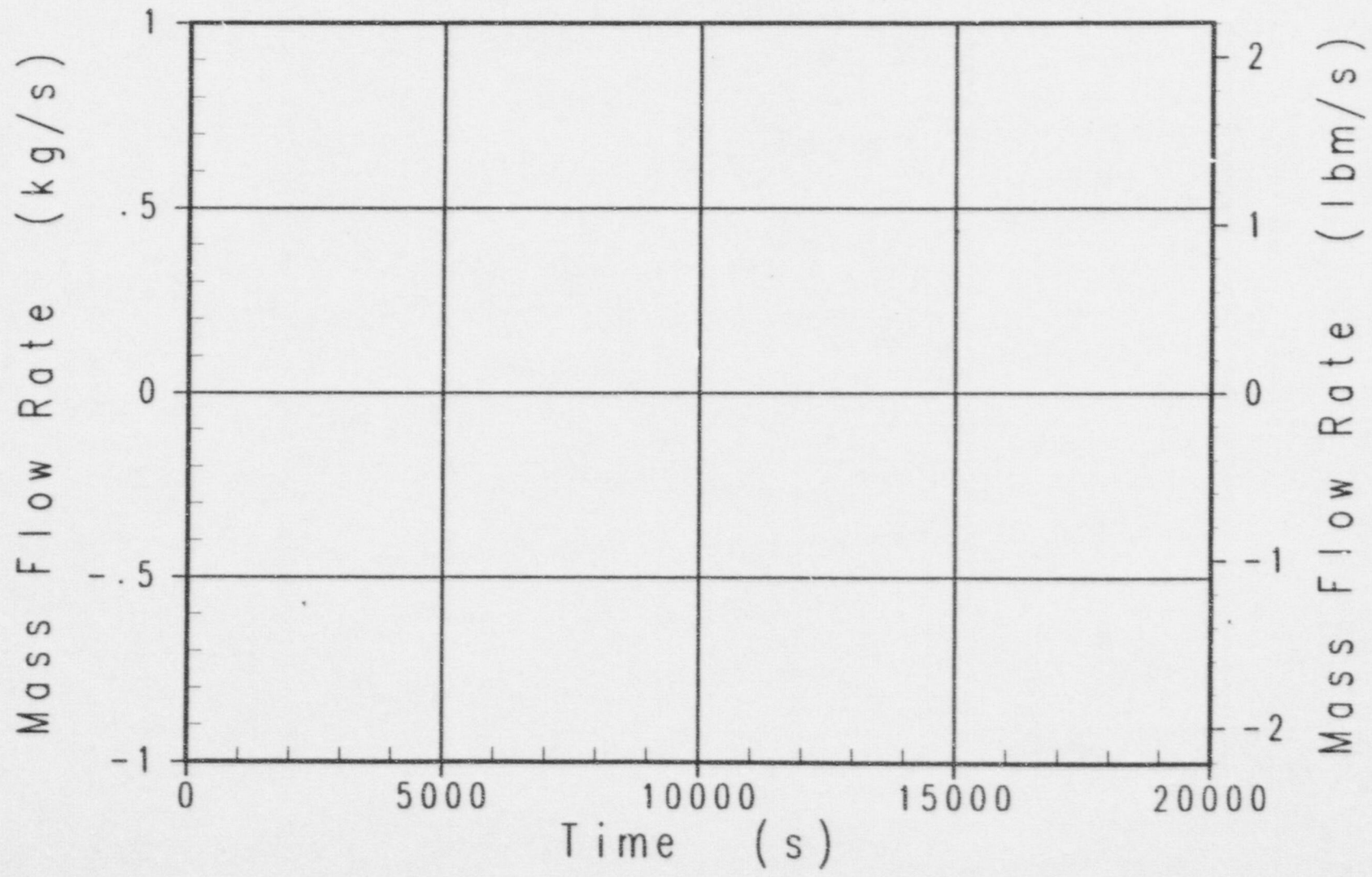

Case t2a AP600 Success Criteria MAAP4 Analysis
ADS Stage 4 Gas Flowrate

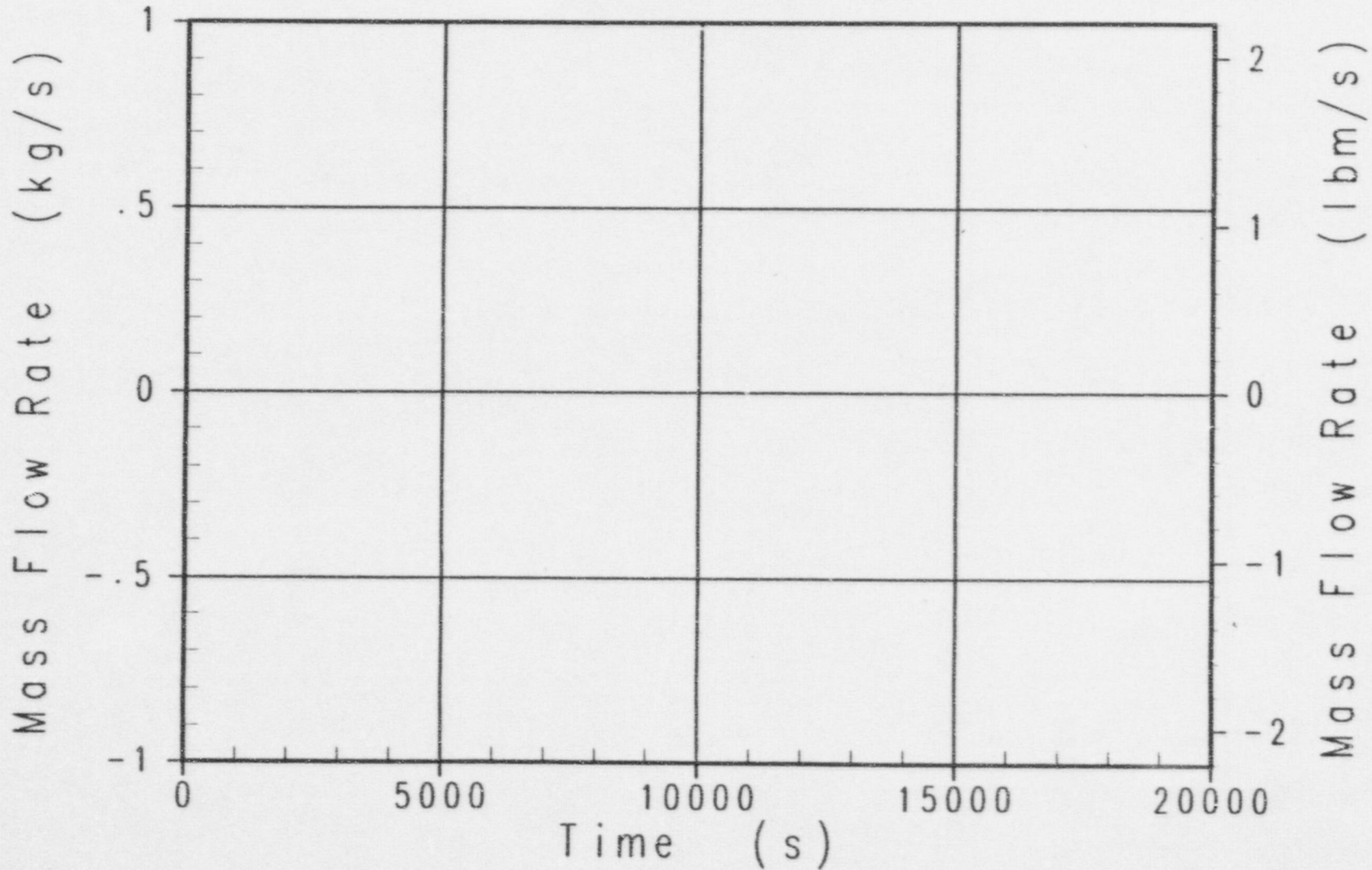

Case t2a AP600 Success Criteria MAAP4 Analysis
Safety Valve and ADS Stages 1-3 Gas Flowrate

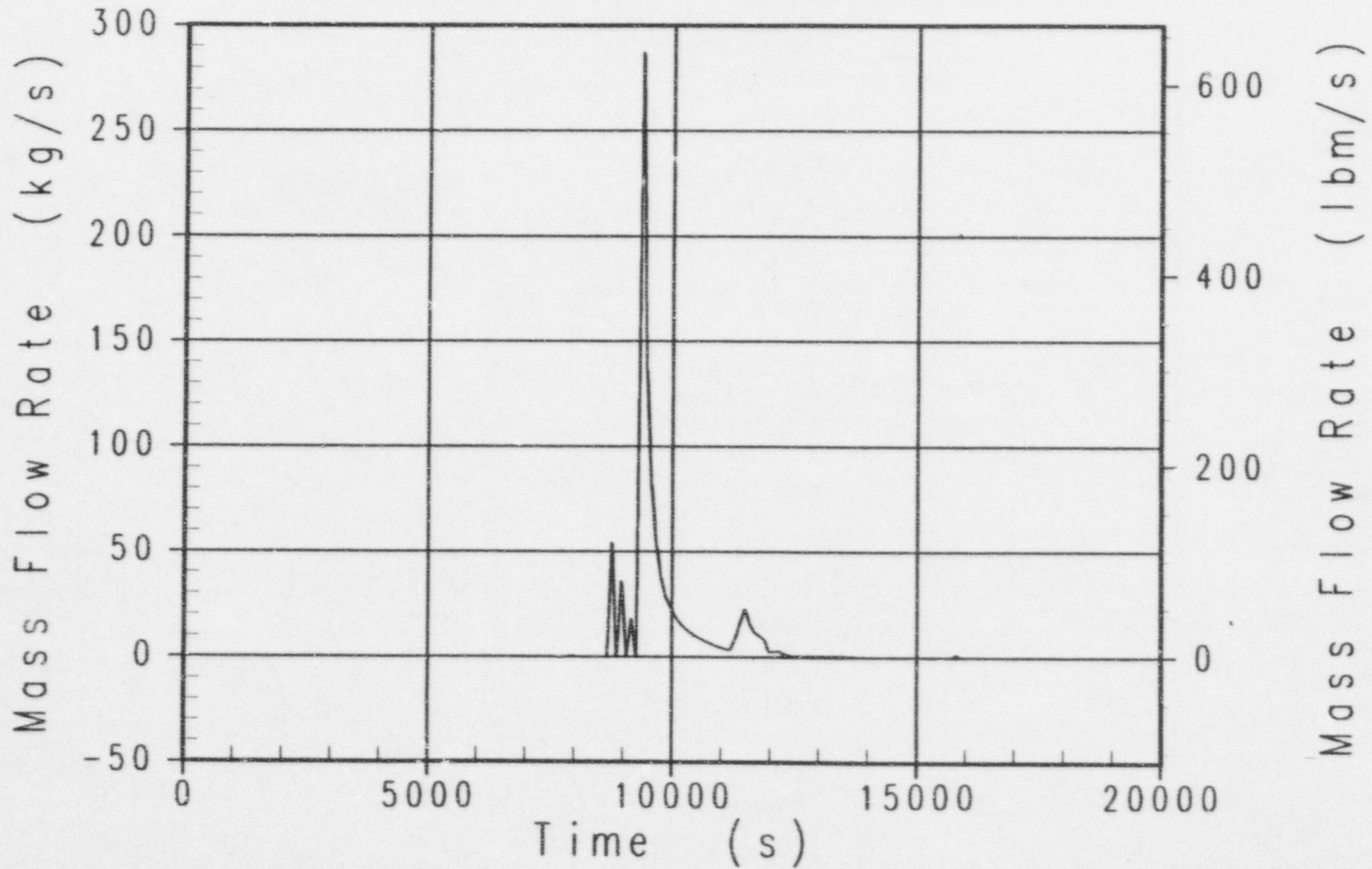

Case t2a AP600 Success Criteria MAAP4 Analysis
RCS Break Liquid Flowrate

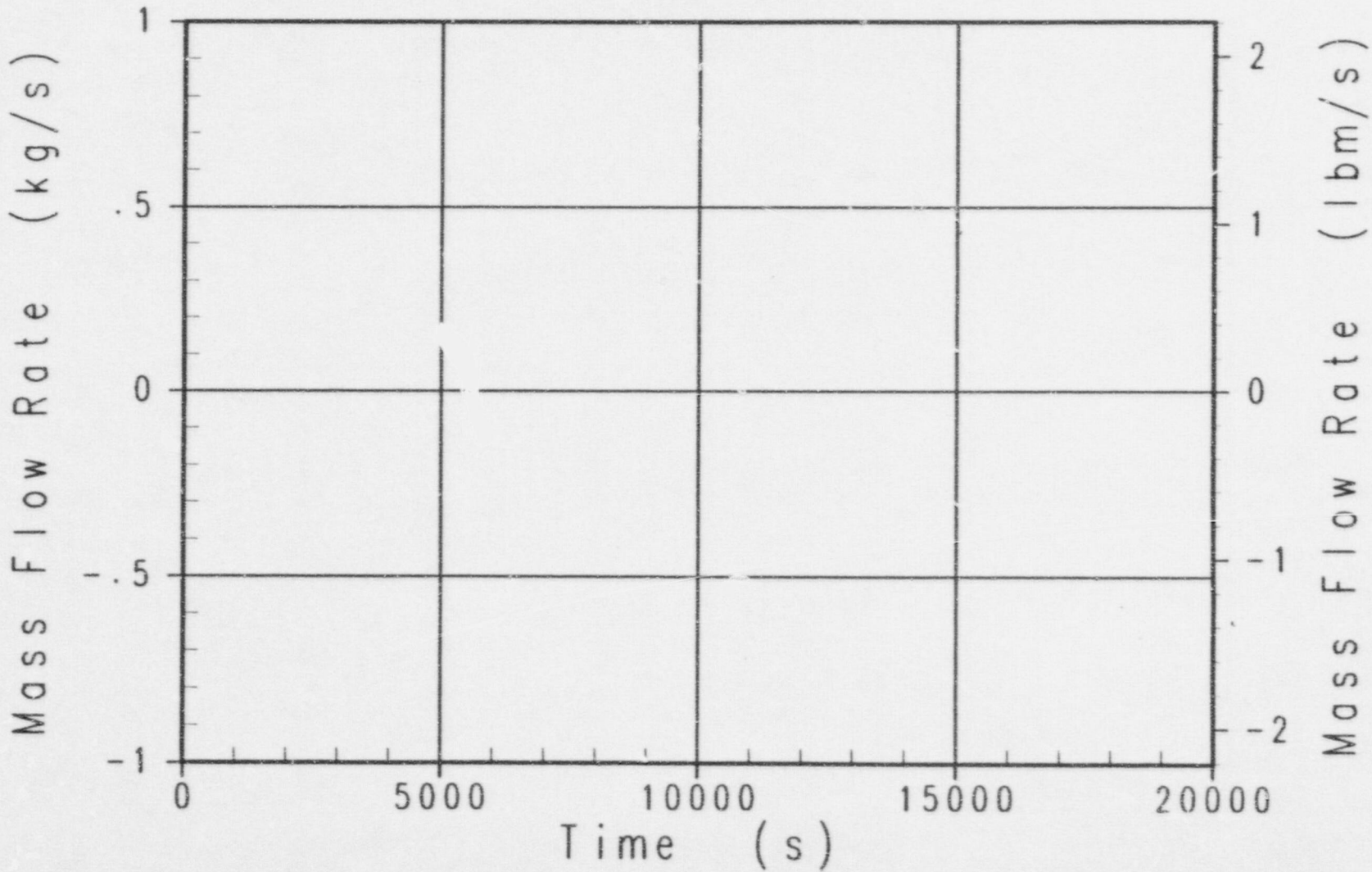

Case t2a AP600 Success Criteria MAAP4 Analysis
ADS Stage 4 Liquid Flowrate

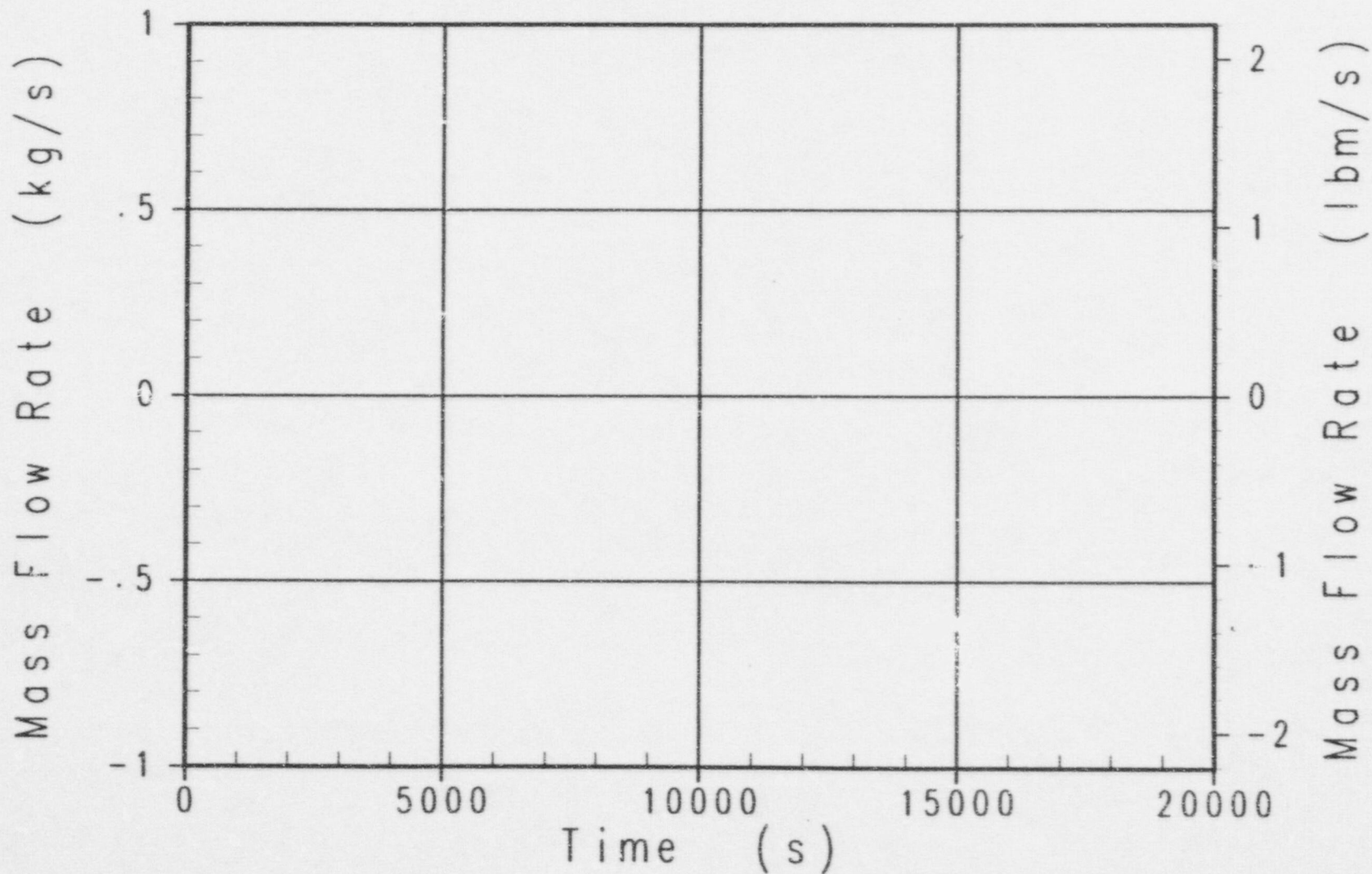

Case t2a AP600 Success Criteria MAAP4 Analysis
IRWST Injection Flowrate (neg. means into RCS)

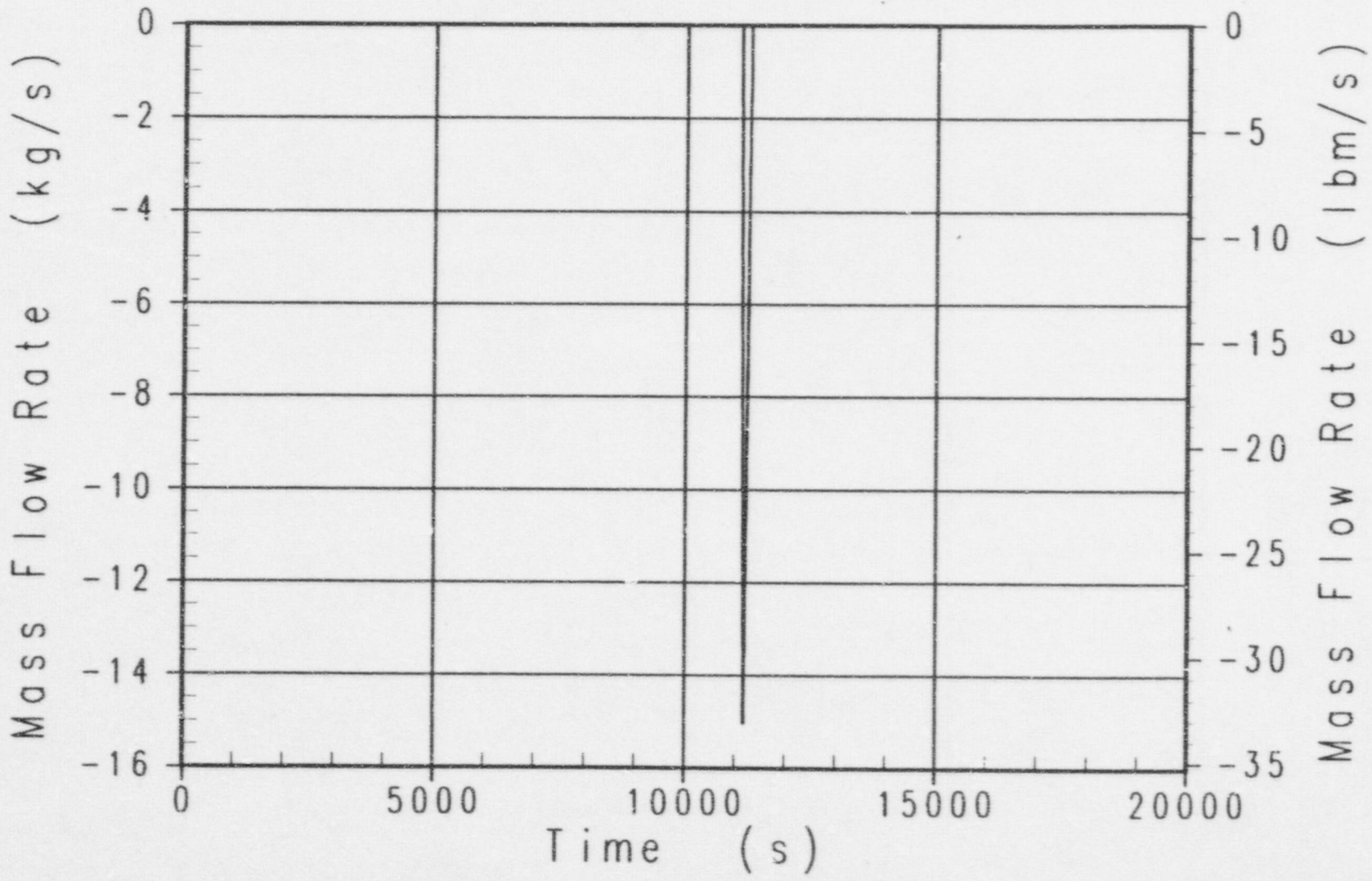

Case t2a AP600 Success Criteria MAAP4 Analysis
CMT-1 Injection Flowrate

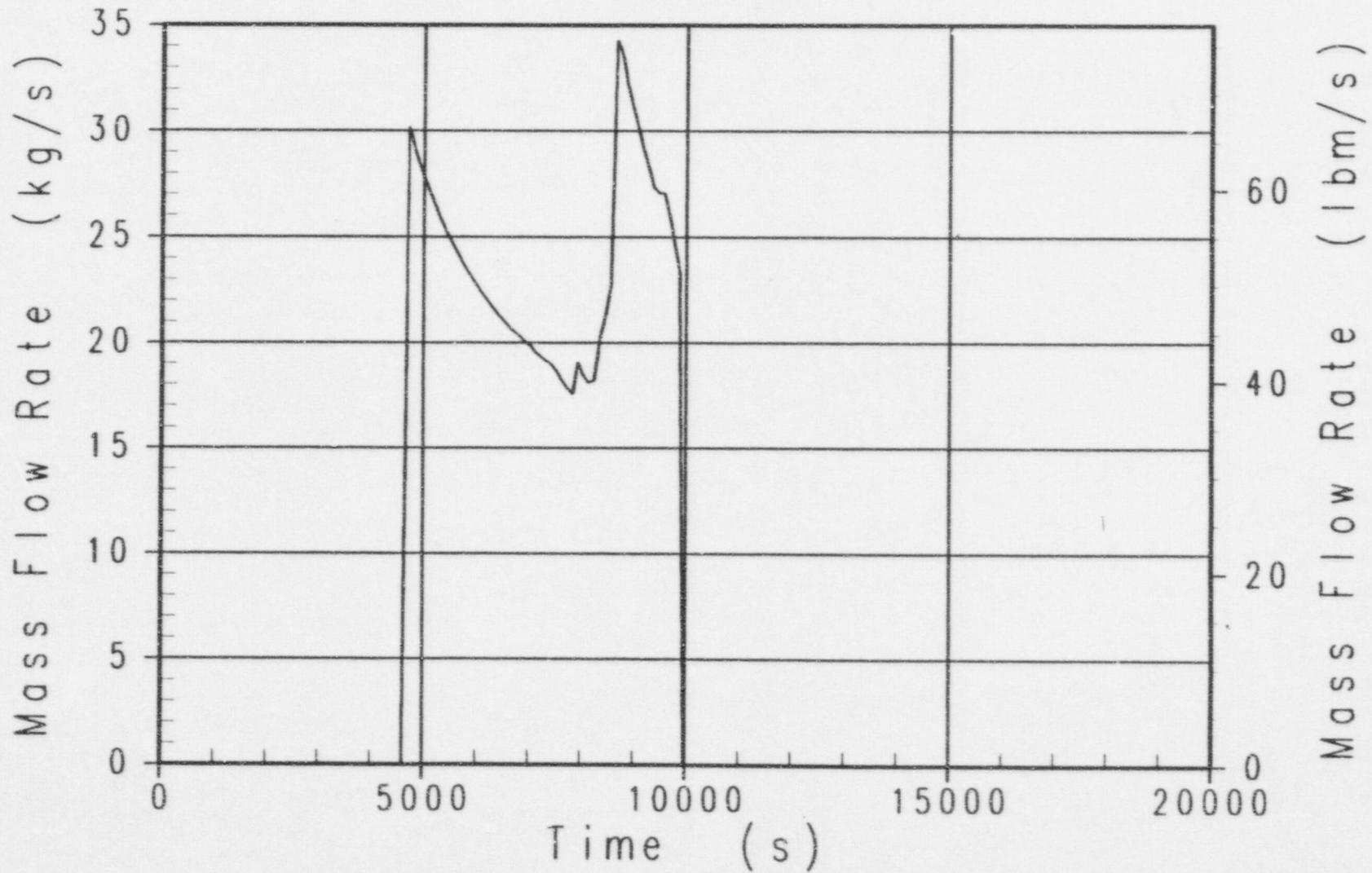

Case 12a AP600 Success Criteria MAAP4 Analysis
Safety Valve and ADS Stages 1-3 Liquid Flowrate

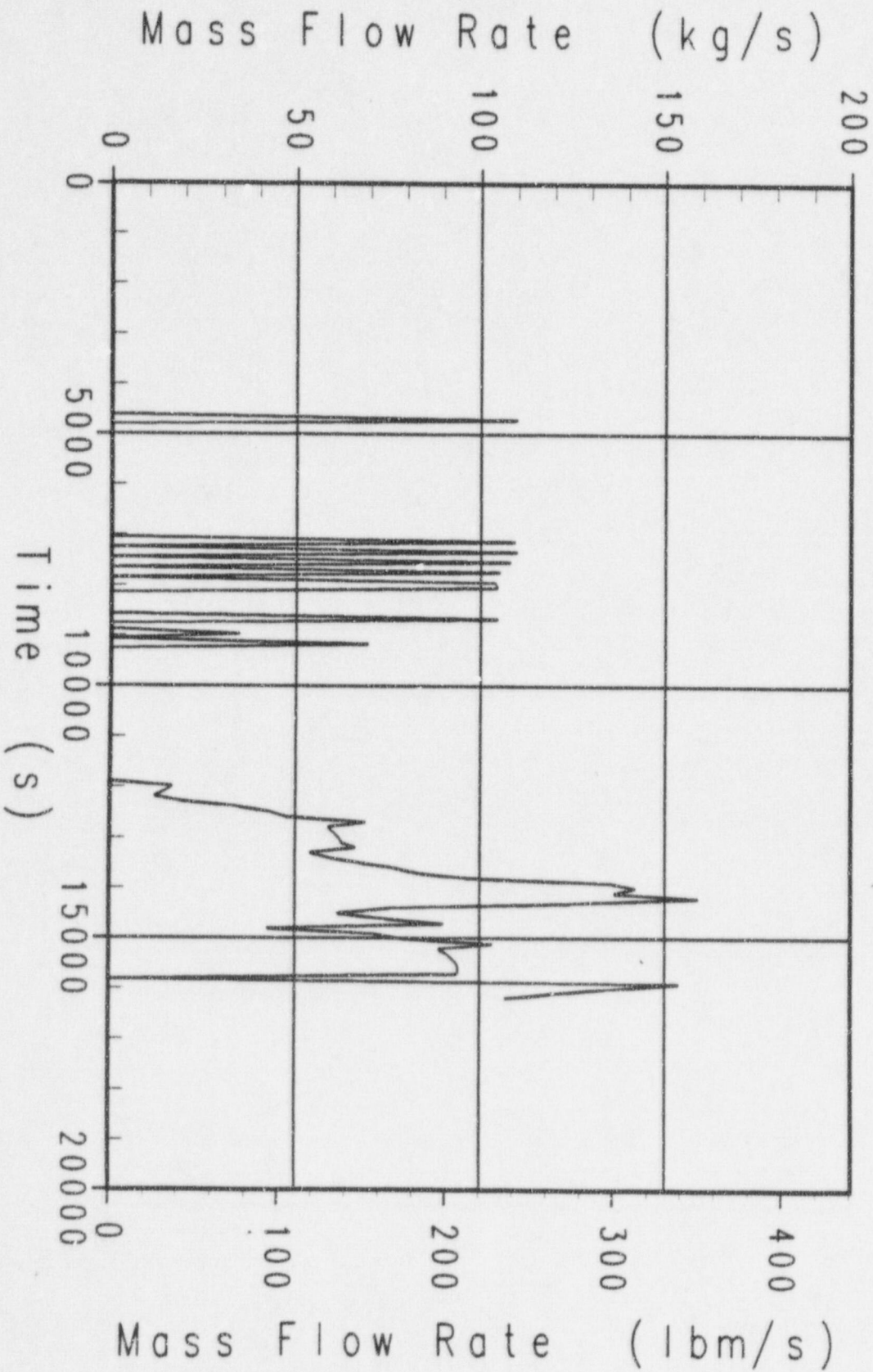

Case t2a AP600 Success Criteria MAAP4 Analysis
CMT-1 Water Level

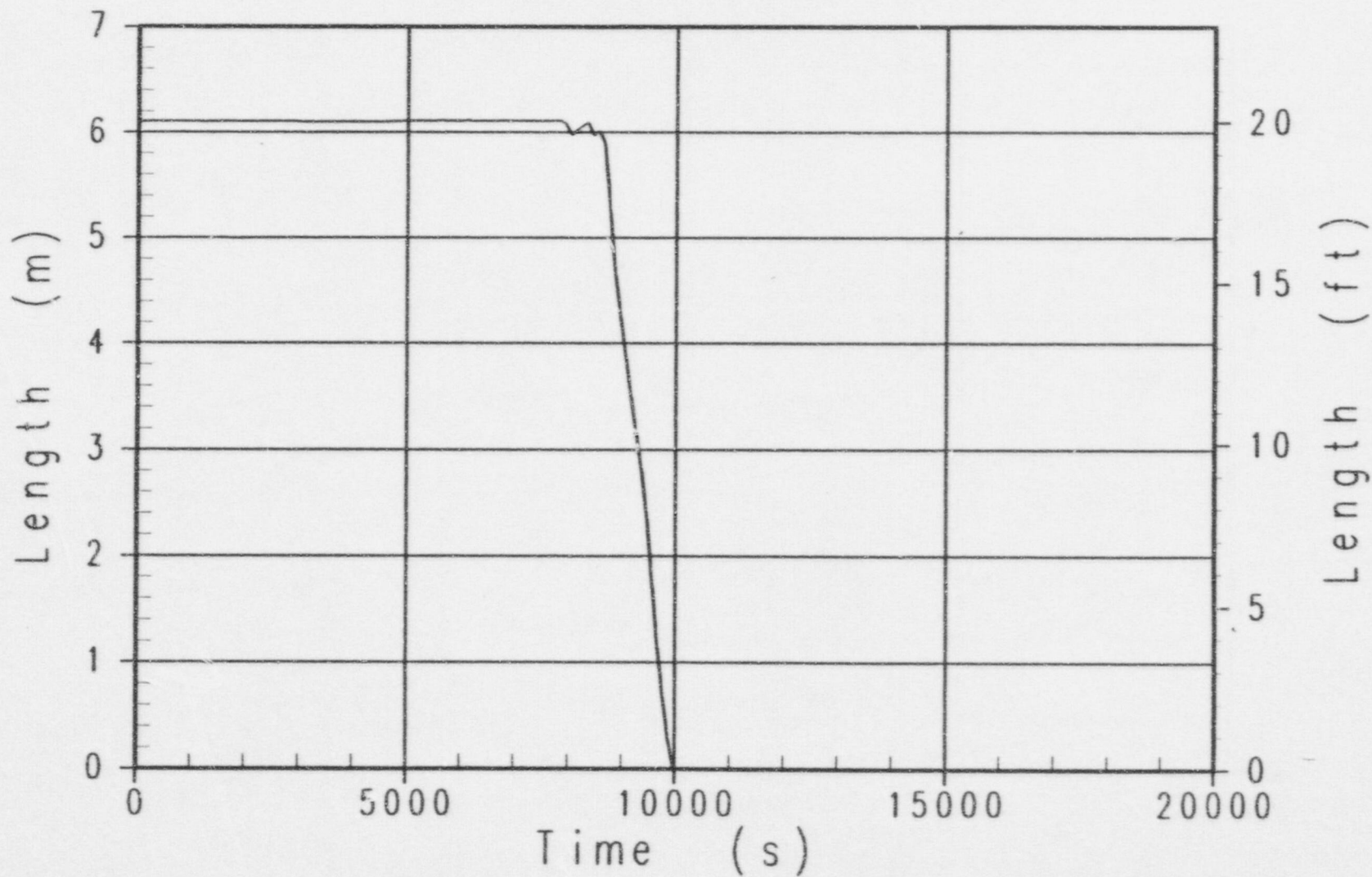

Case t2a AP600 Success Criteria MAAP4 Analysis
Pressurizer Water Level (From Pzr Bottom)

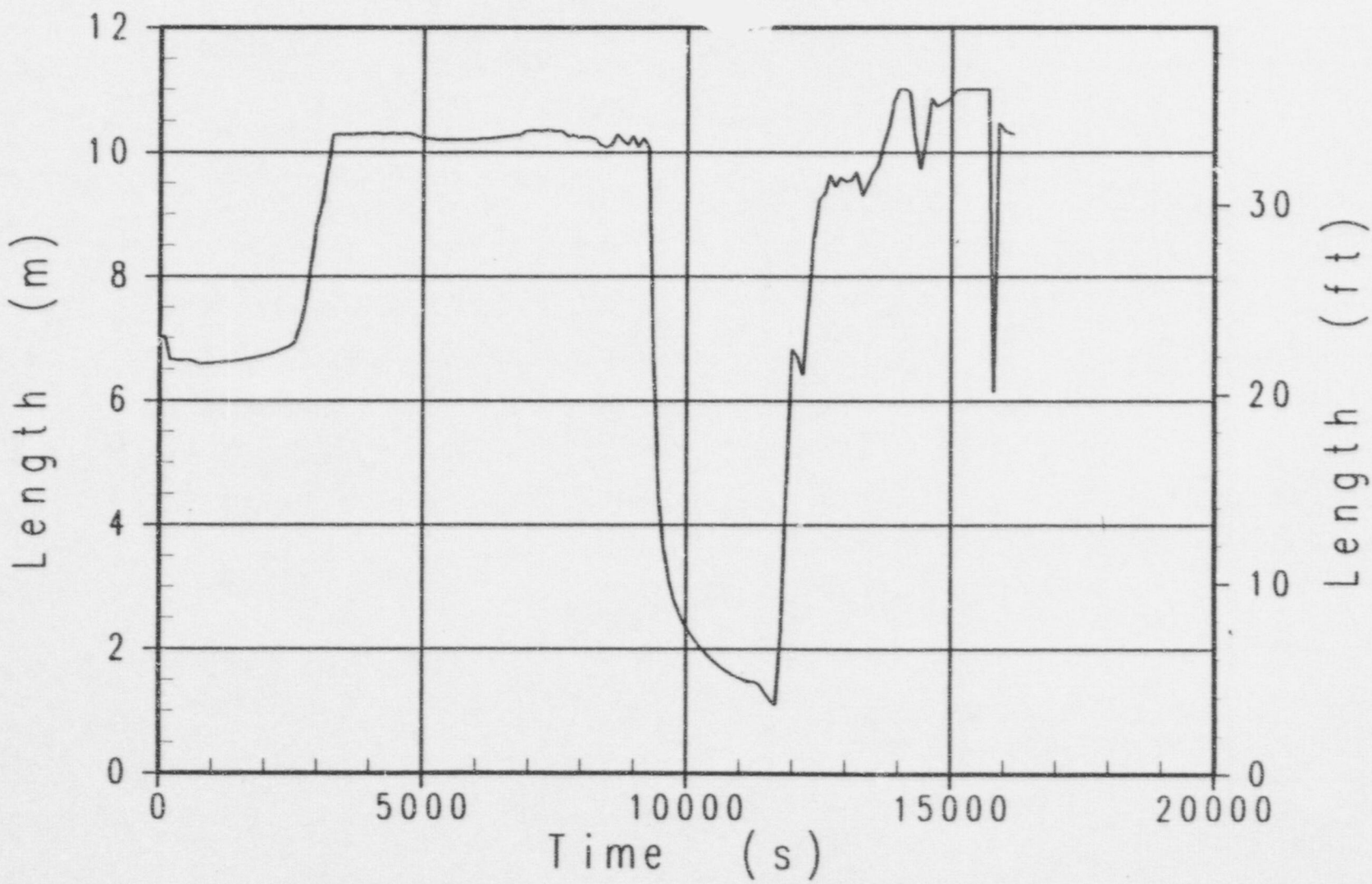

Case t5t AP600 Success Criteria MAAp4 Analysis
Broken Loop Steam Generator Pressure

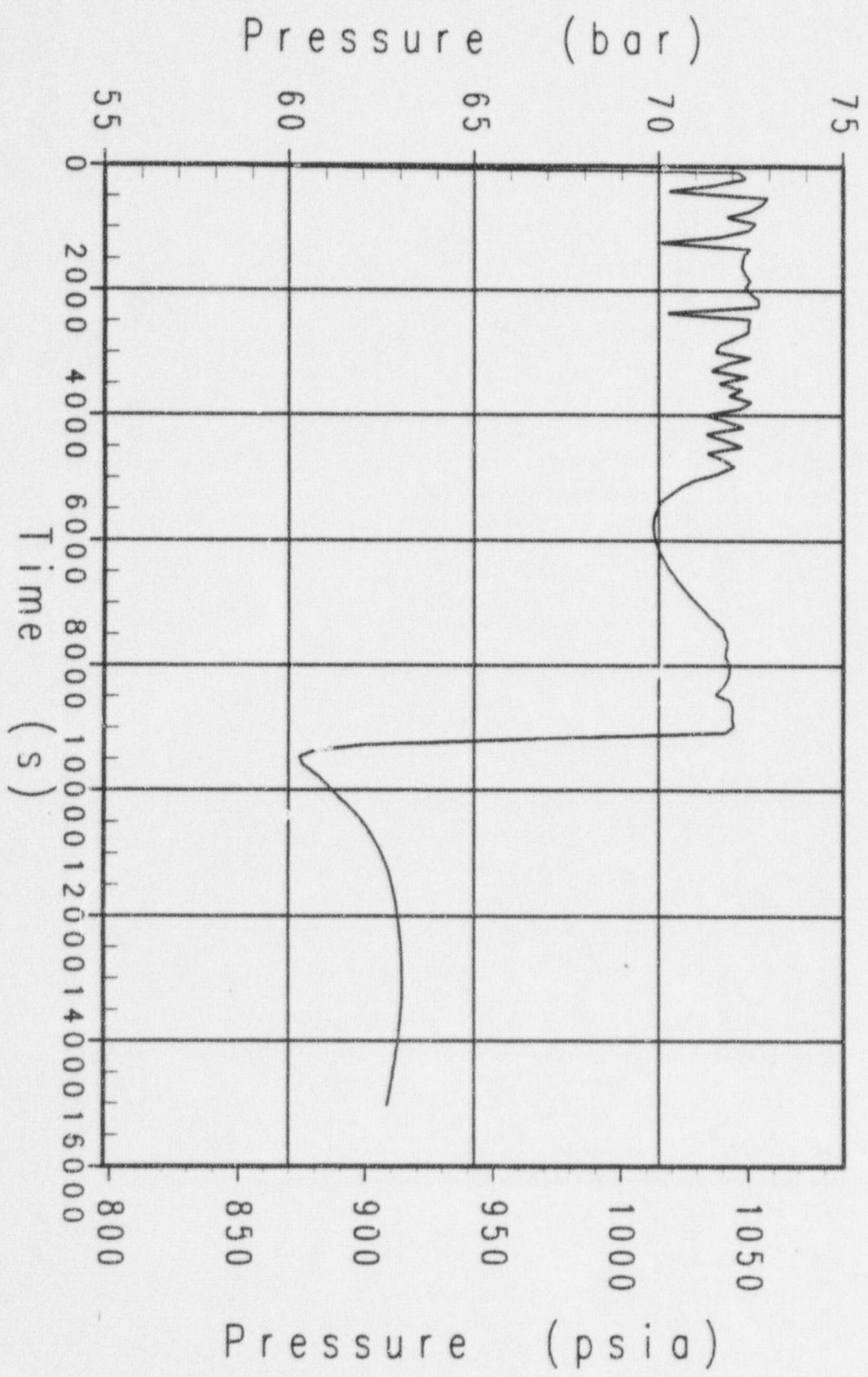

Case t5t AP600 Success Criteria MAAP4 Analysis
Primary System Pressure

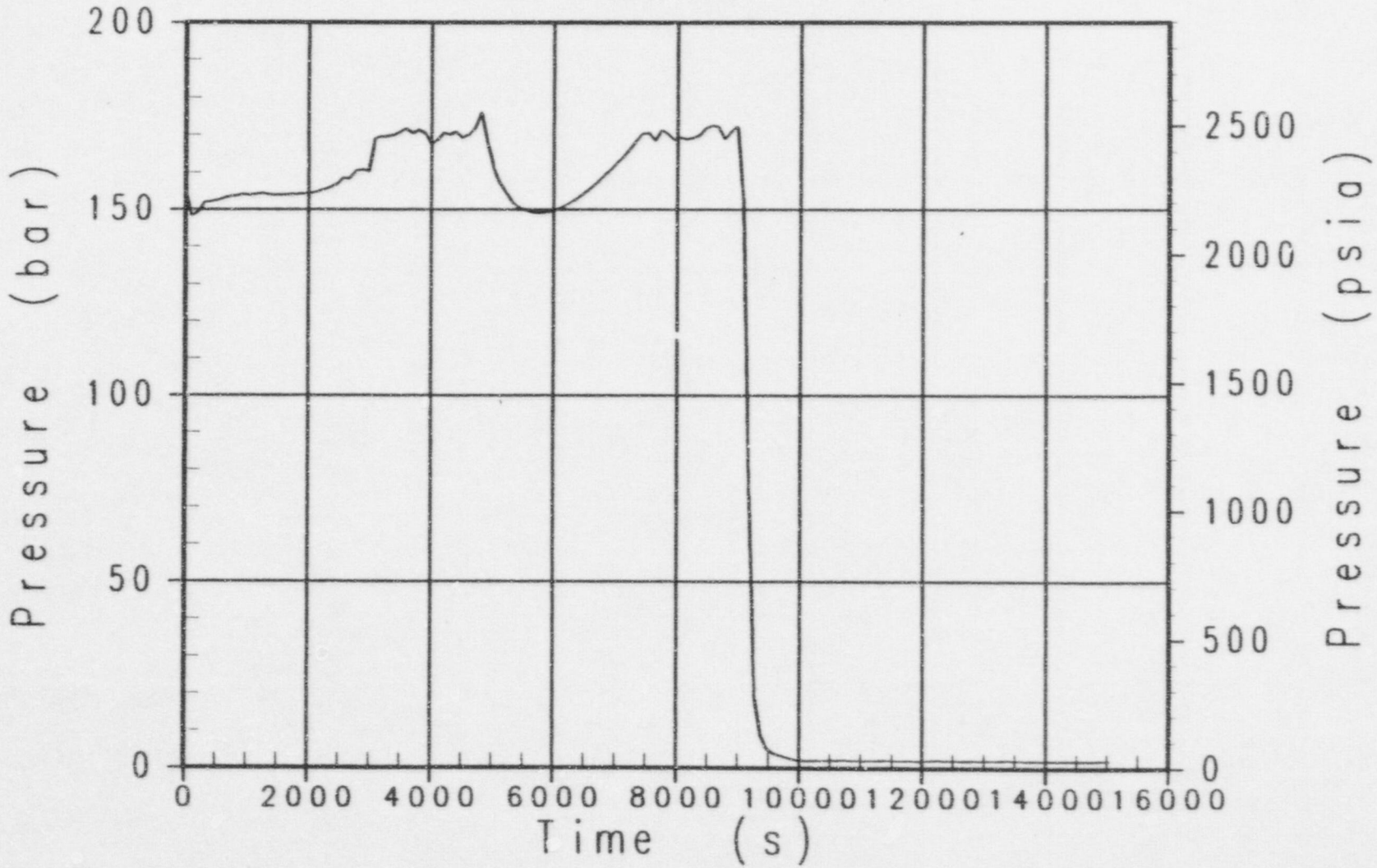

Cose t5t AP600 Success Criteria MAAP4 Analysis
Containment Pressure

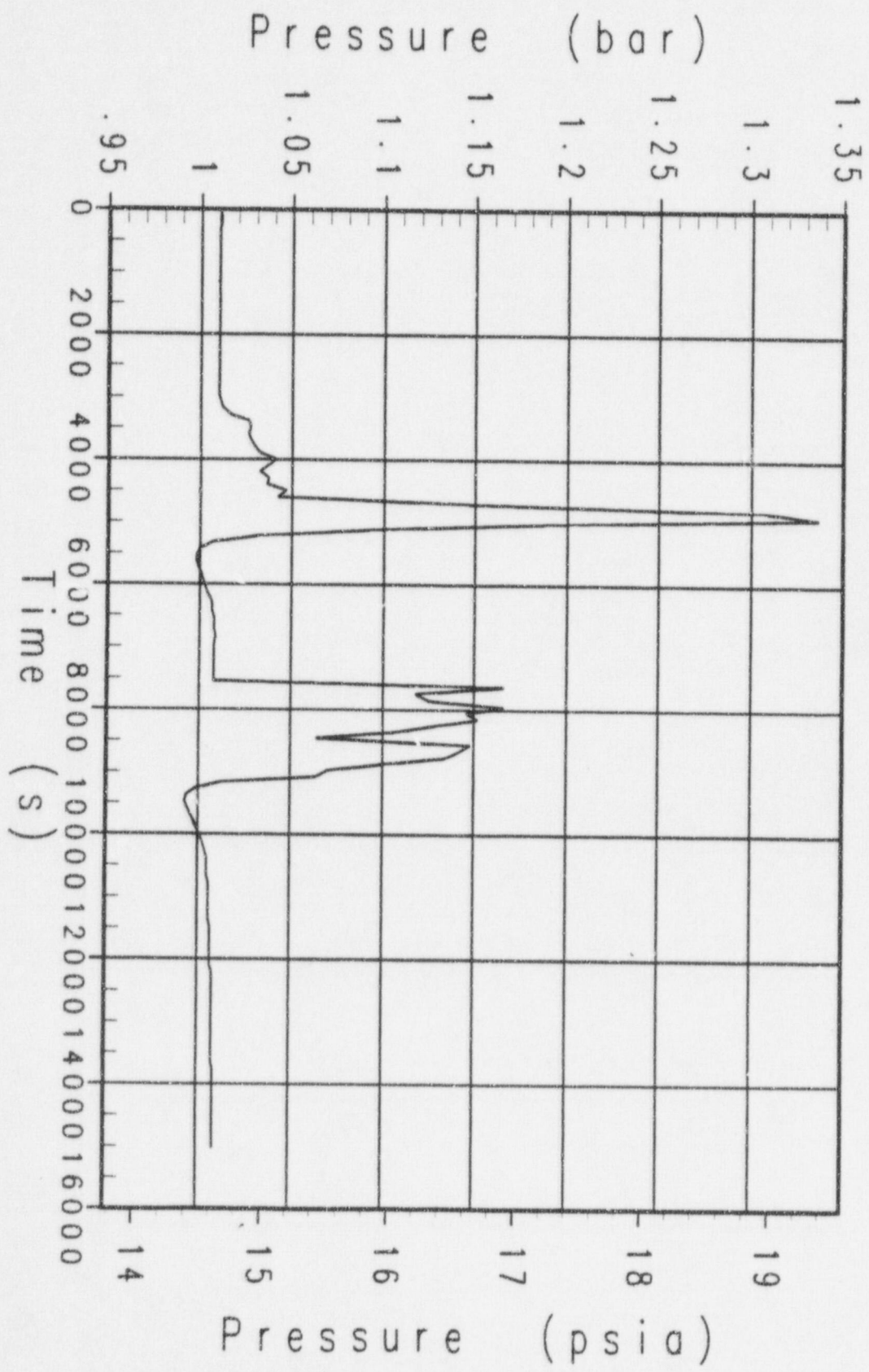

Case 15t AP600 Success Criteria MAAp4 Analysis
Unbroken Loop Steam Generator Pressure

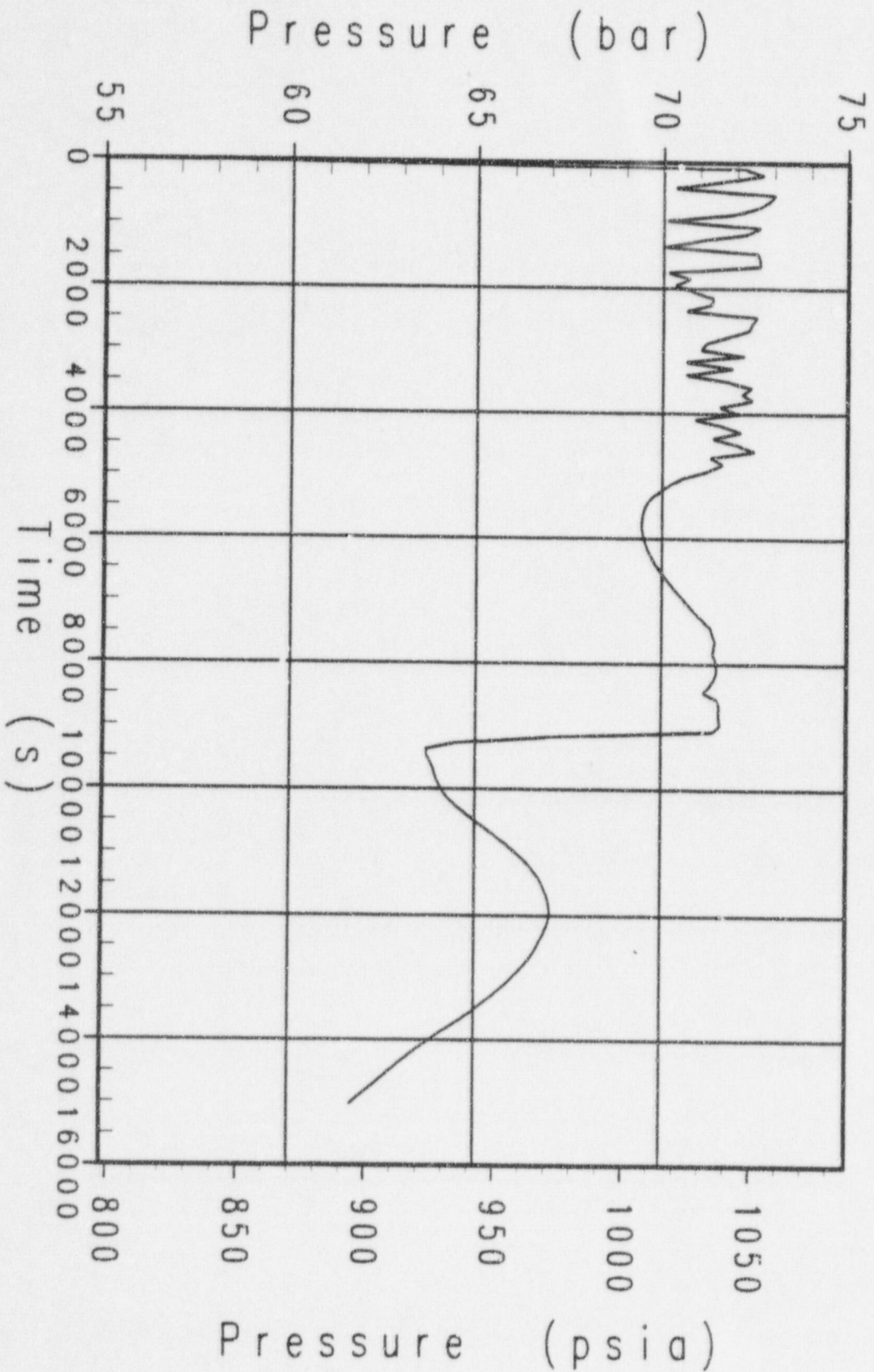

Case t5t AP600 Success Criteria MAAP4 Analysis
Decay Power

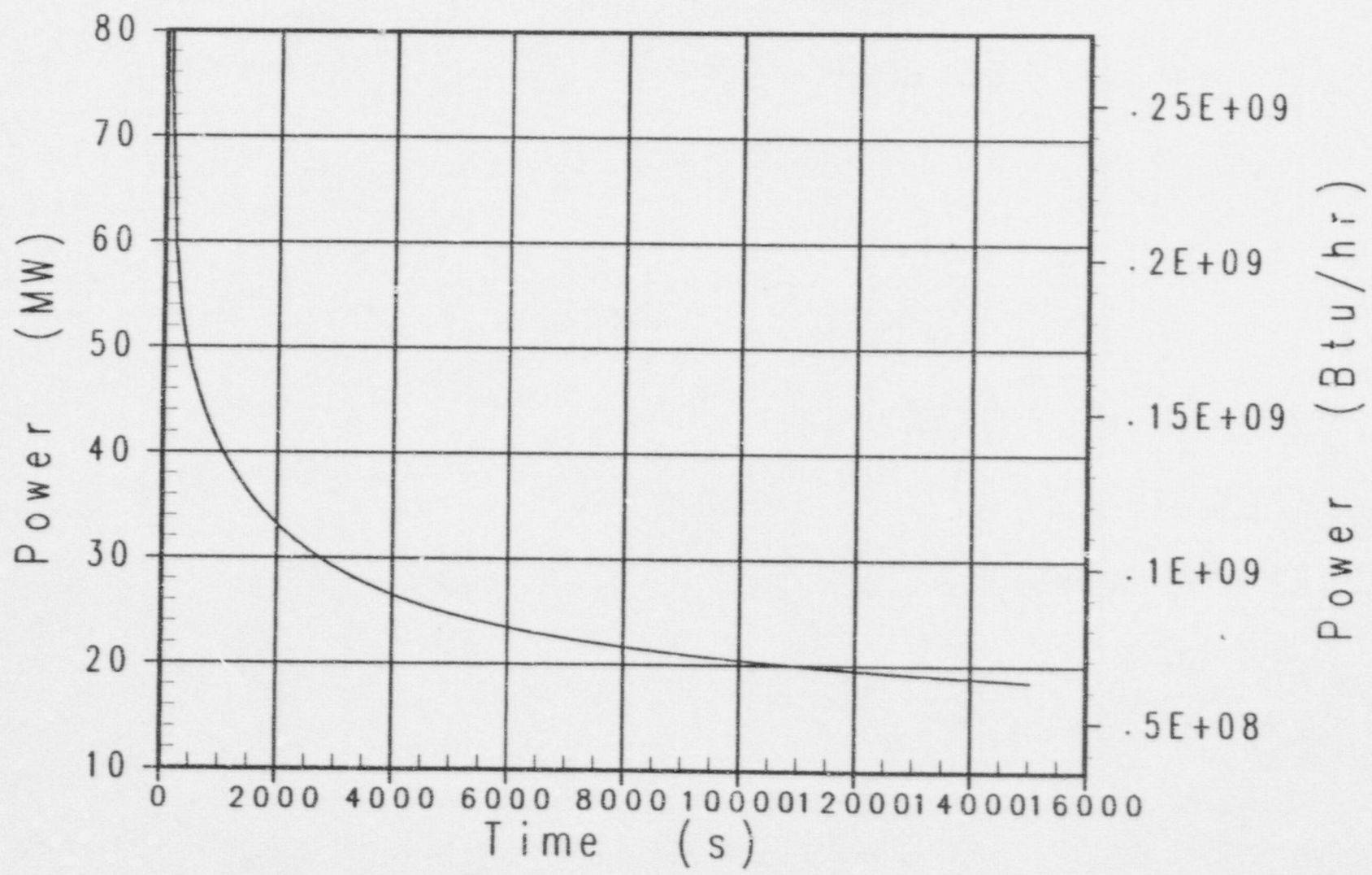

Case t5t AP600 Success Criteria MAAP4 Analysis
PRHR Heat Removal Rate

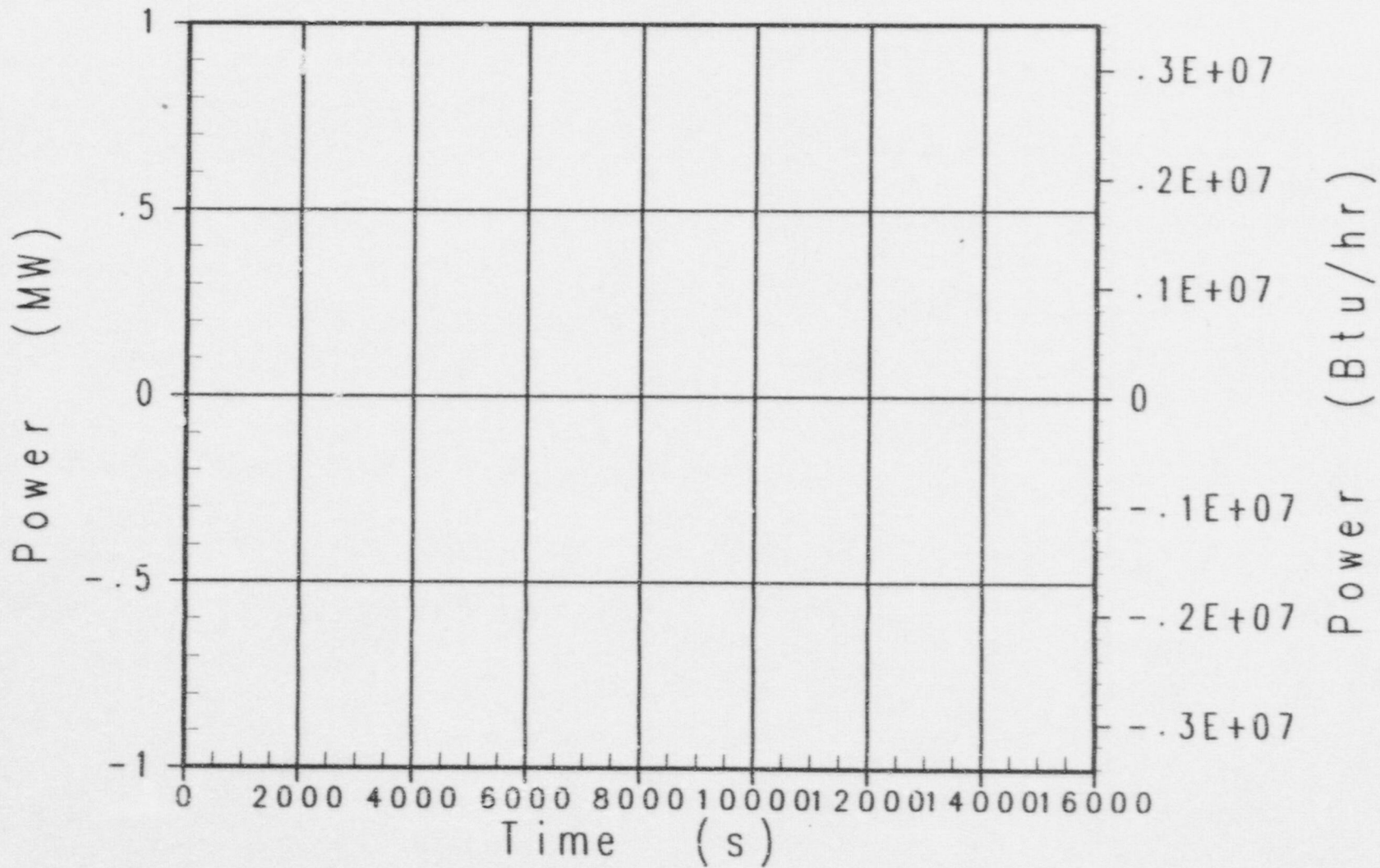

Case t5t AP600 Success Criteria MAAP4 Analysis
Peak Temperature in the Core

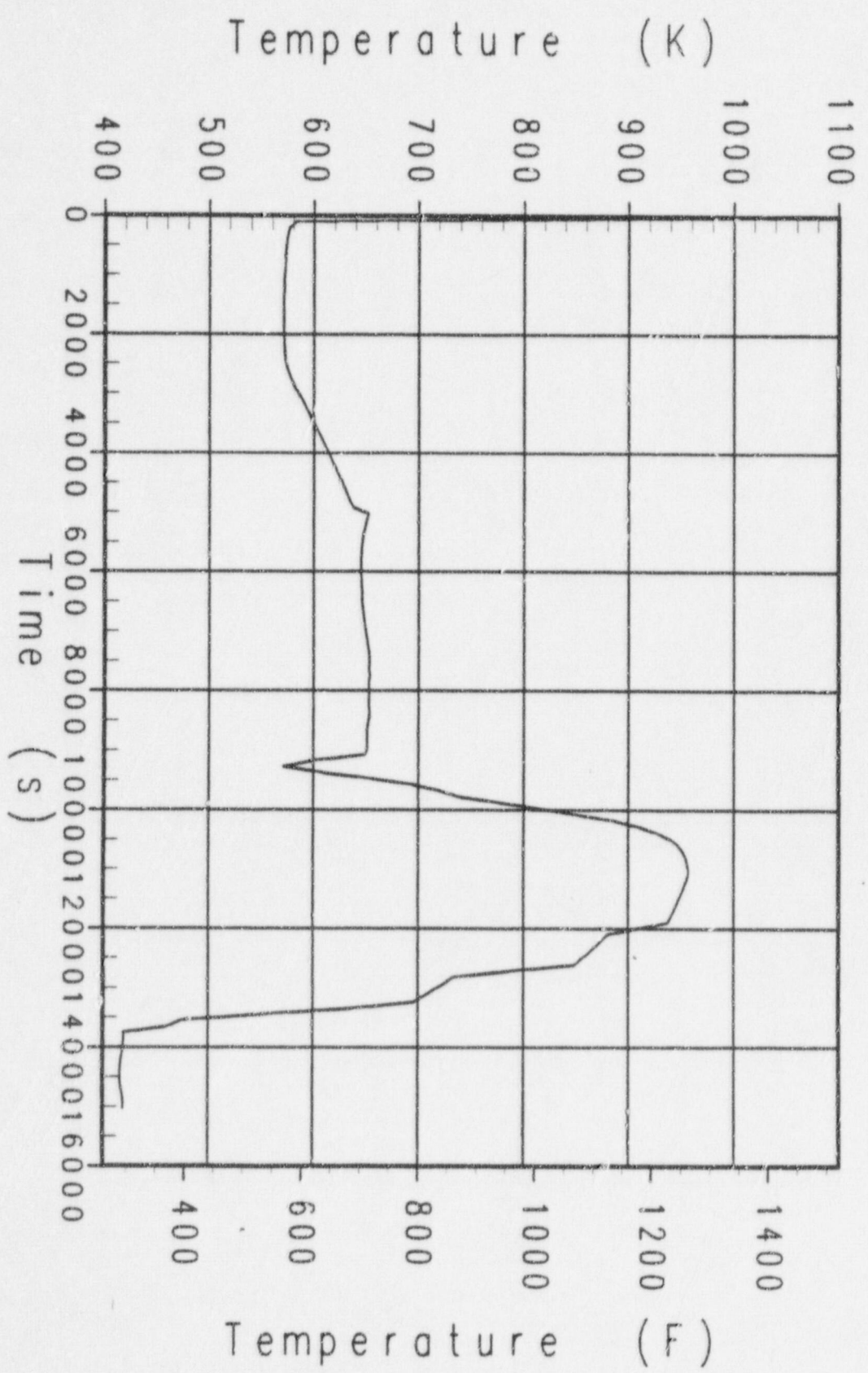

Case 151 AP600 Success Criteria MAAP4 Analysis
Cold Leg Water Temperature

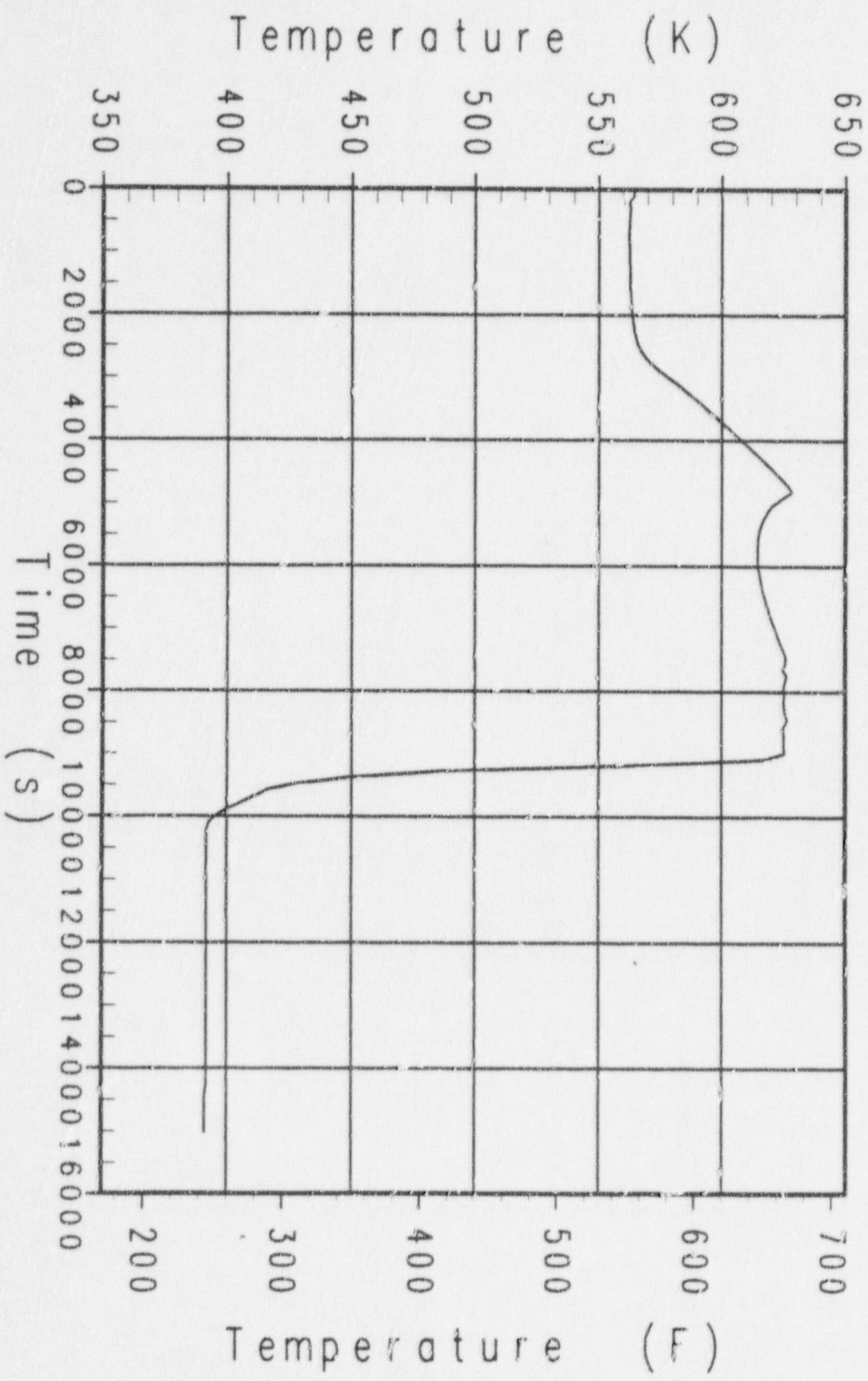

Case 151 AP600 Success Criteria MAAP4 Analysis
Core Water Temperature

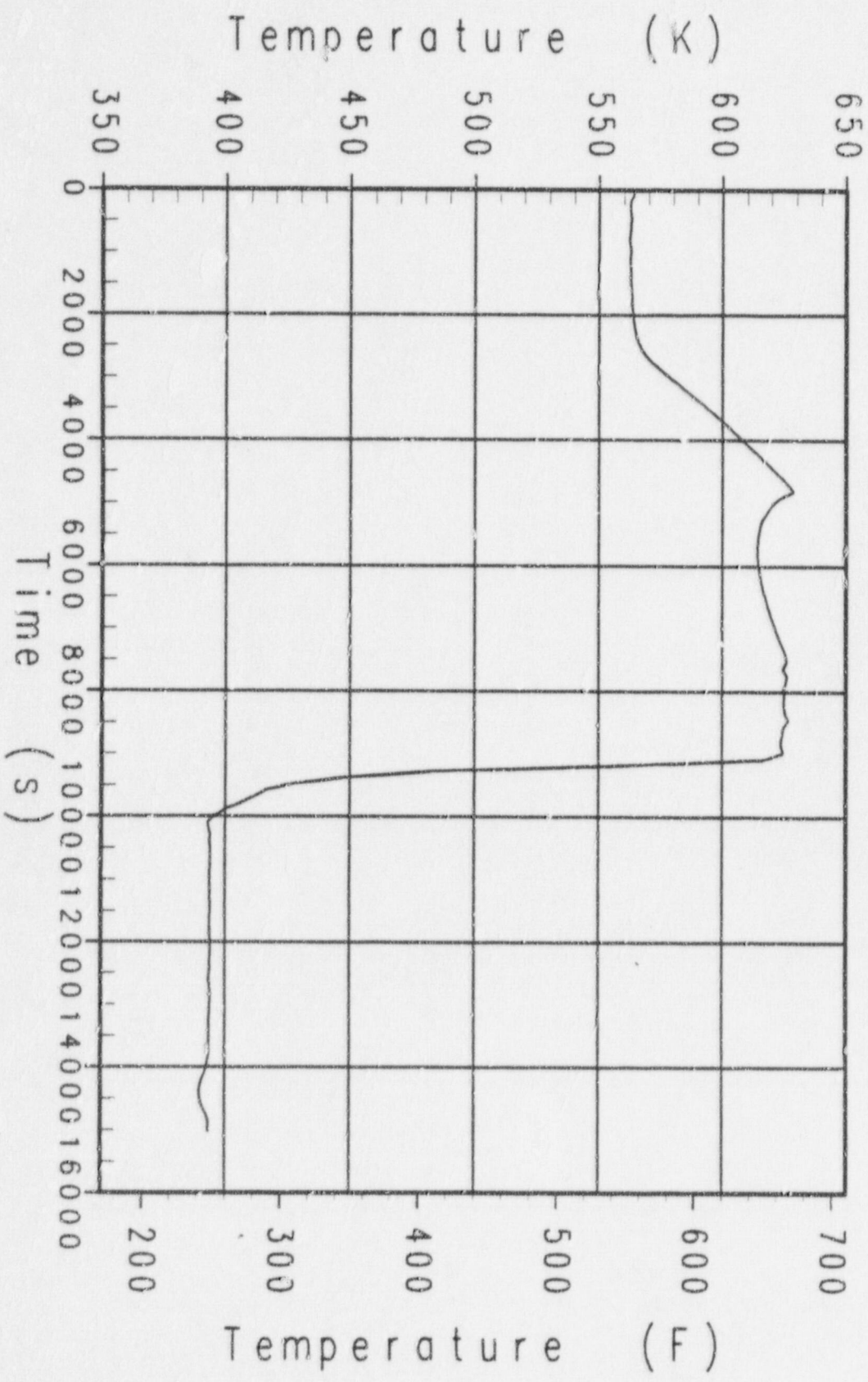

Case t5t AP600 Success Criteria MAAP4 Analysis
RPV Downcomer Water Temperature

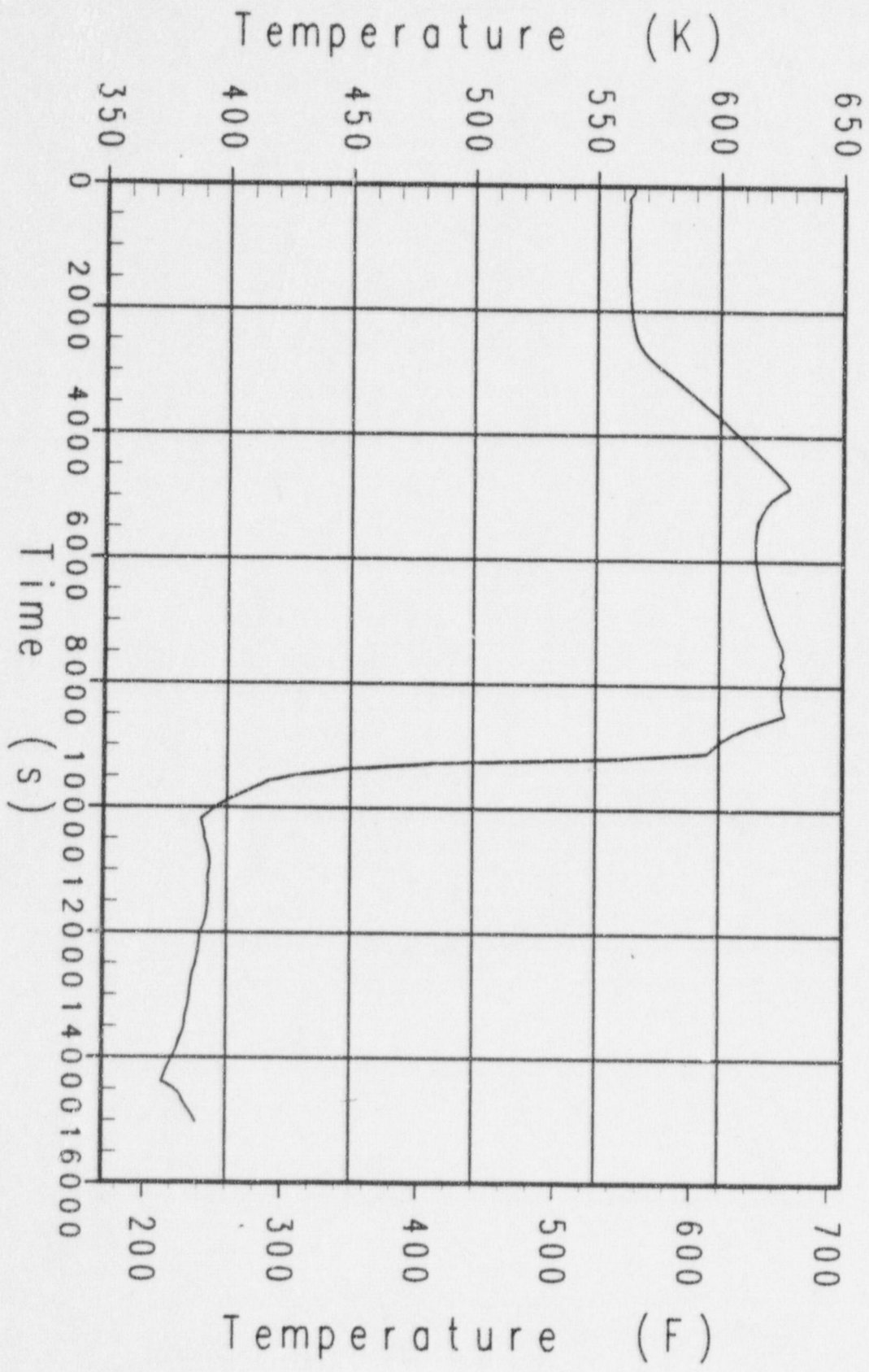

Case t5t AP600 Success Criteria MAAP4 Analysis
IRWST Water Temperature

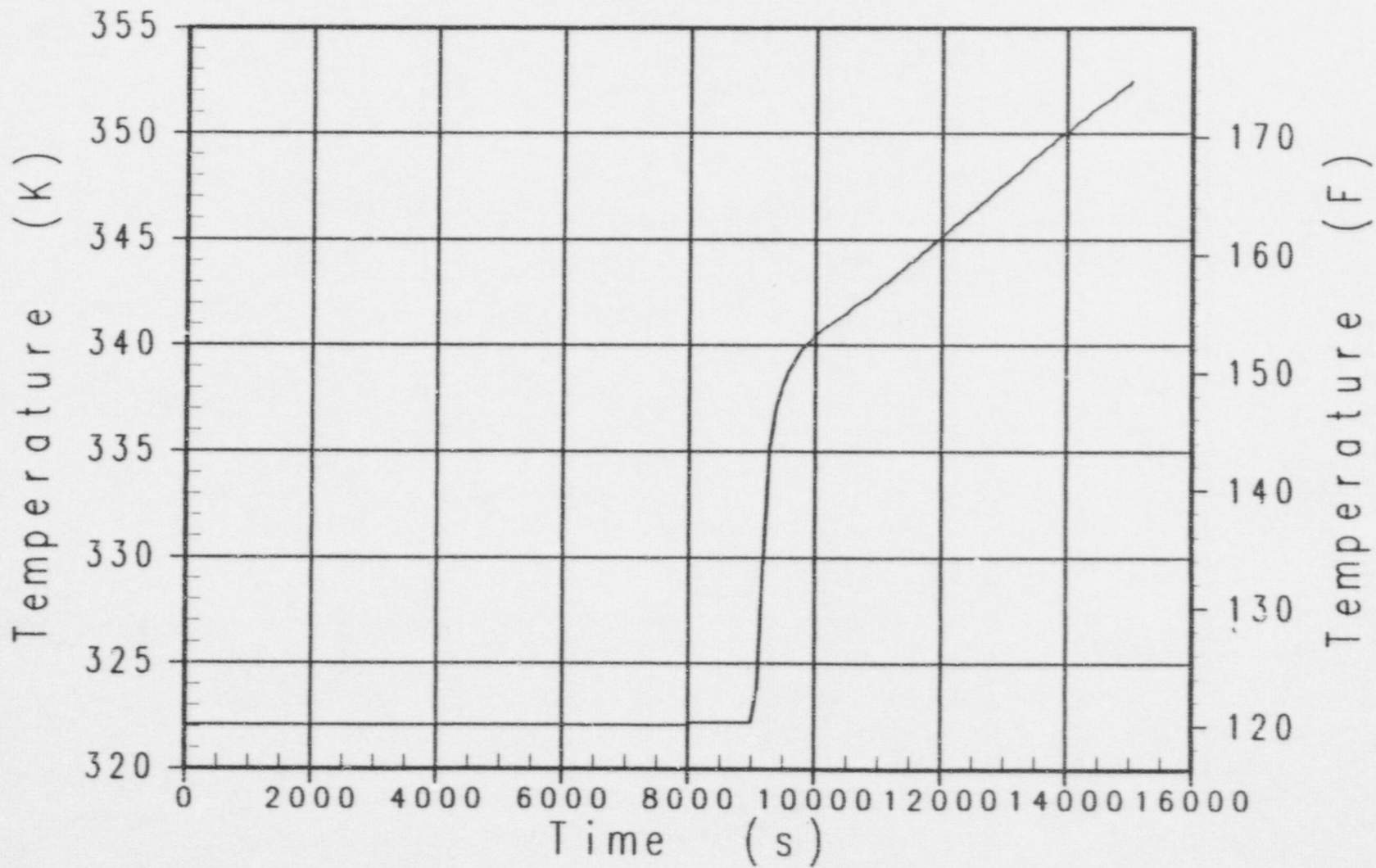

Case 15t AP600 Success Criteria MAAP4 Analysis
Accumulator and NRHR Injection Flowrate

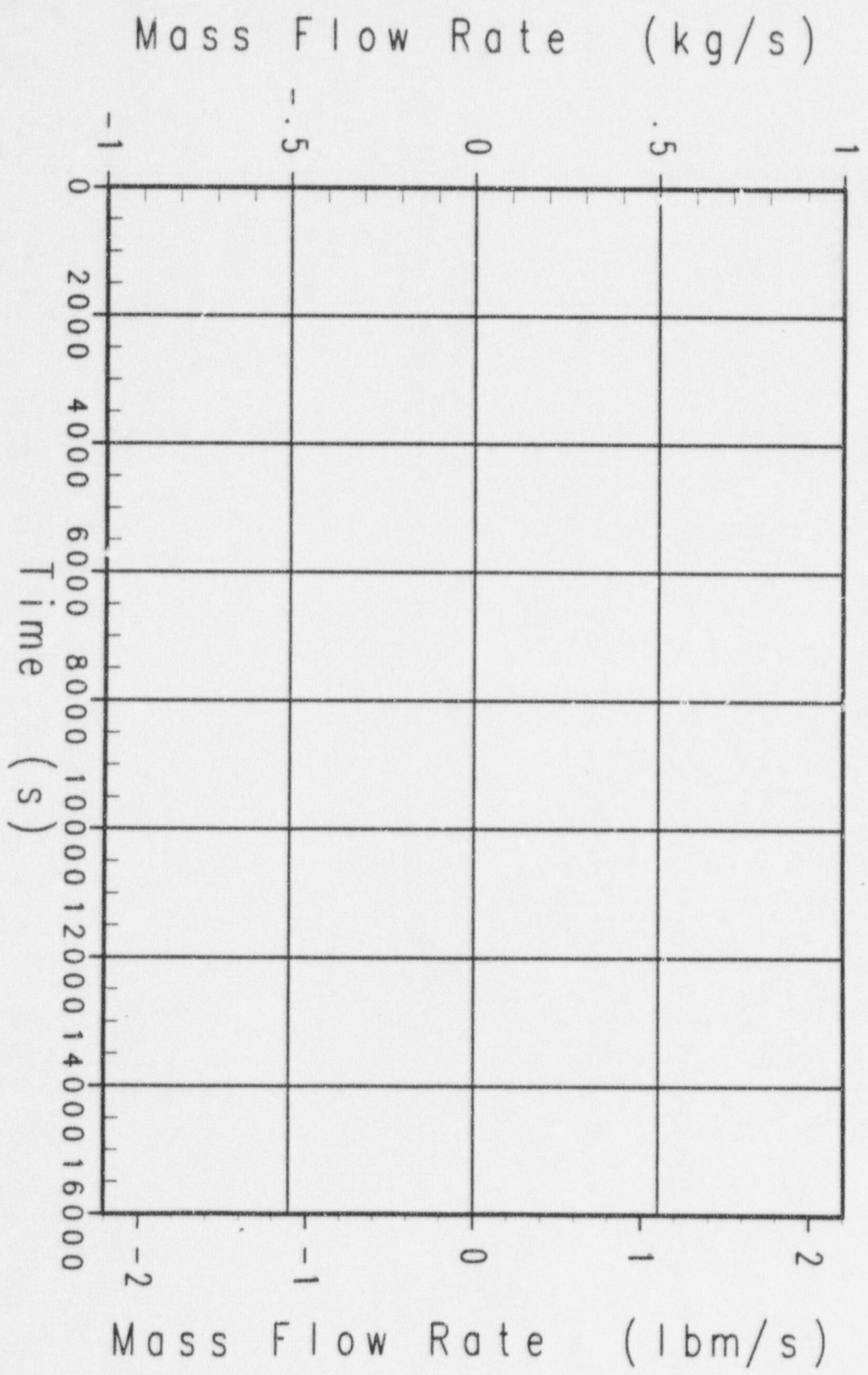

Case 15t AP600 Success Criteria MAAP4 Analysis
RCS Break Gas Flowrate

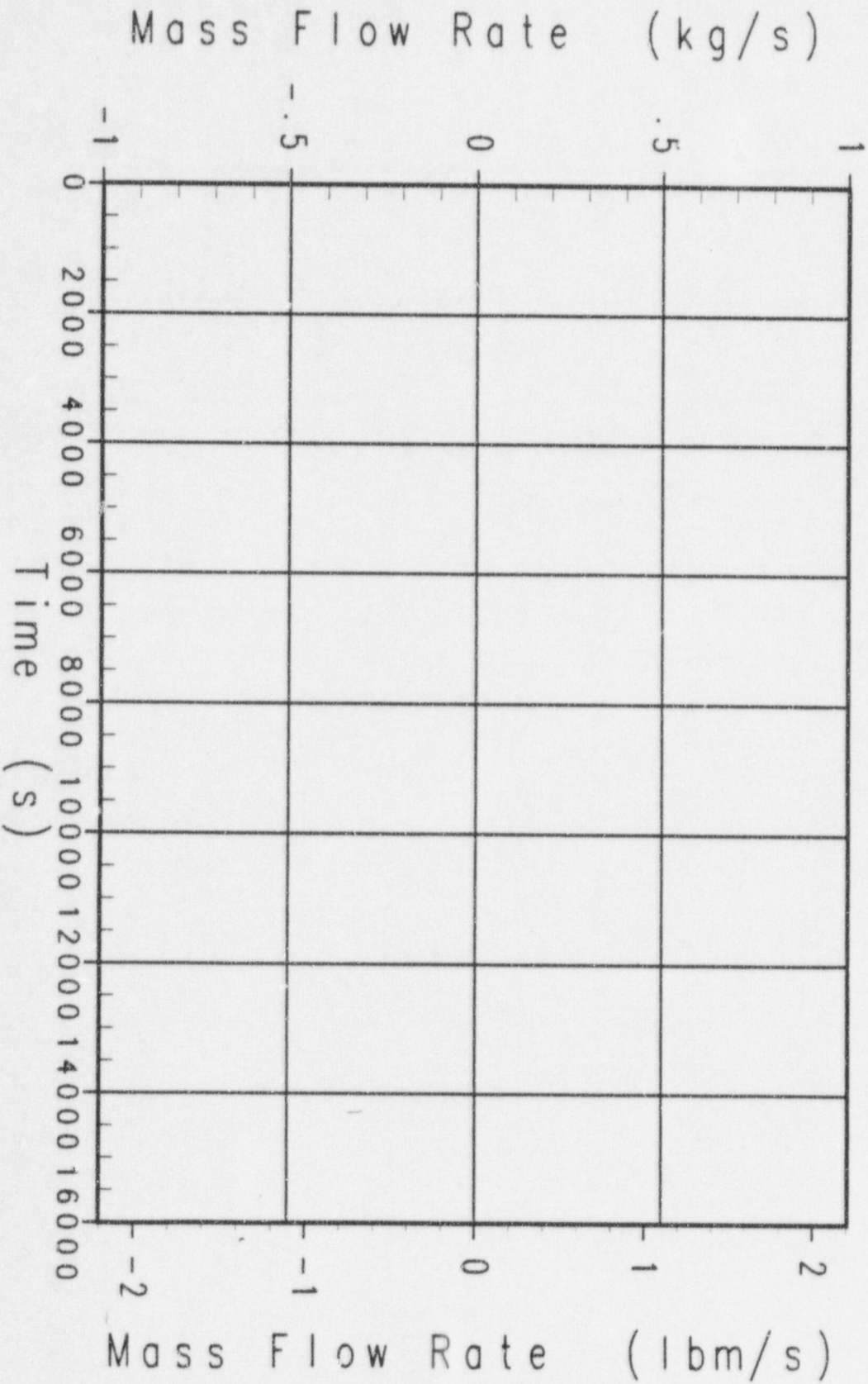

Case t5t AP600 Success Criteria MAAP4 Analysis
ADS Stage 4 Gas Flowrate

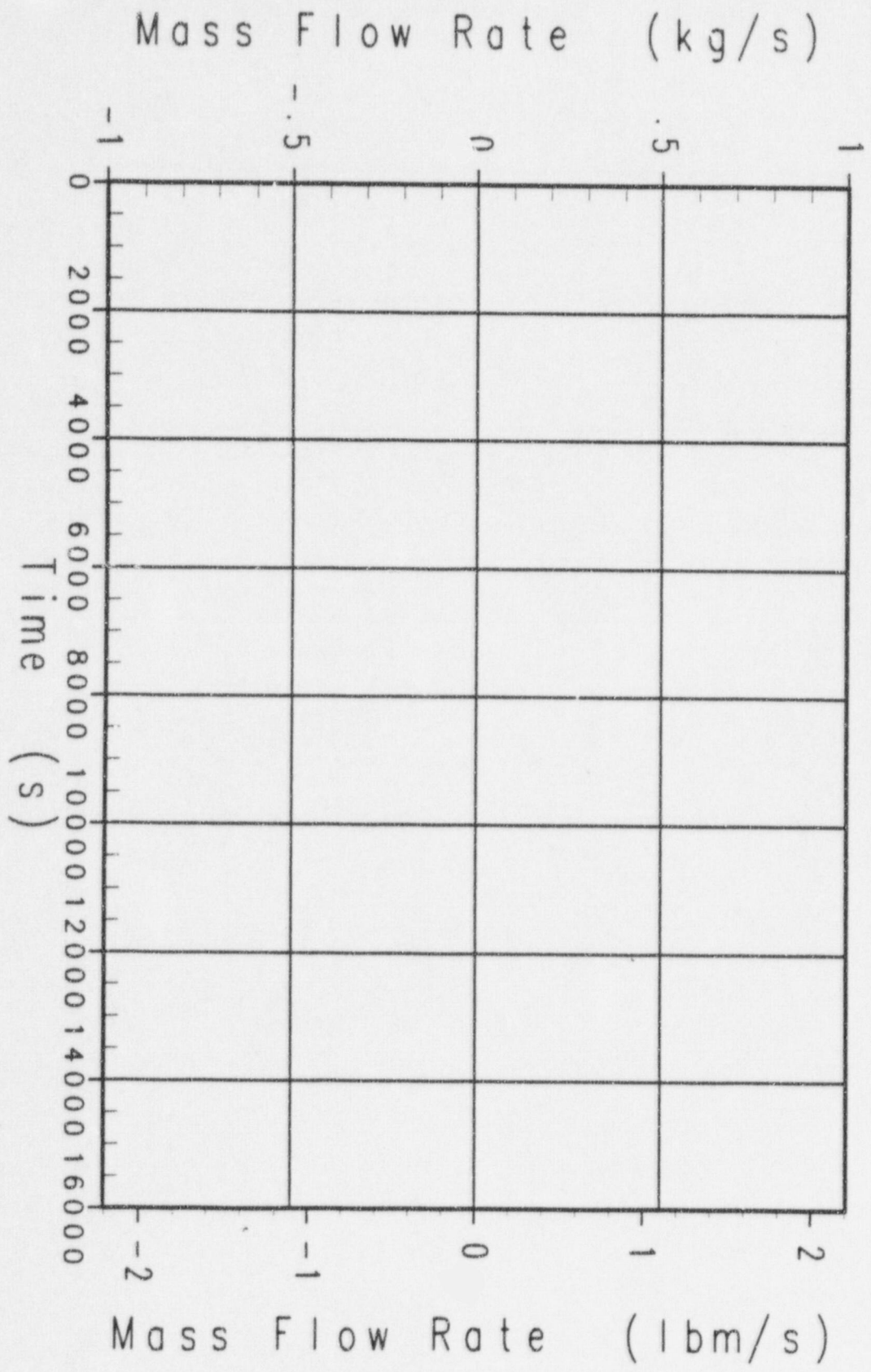

Case 15t AP600 Success Criteria MAAP4 Analysis
Safety Valve and ADS Stages 1-3 Gas Flowrate

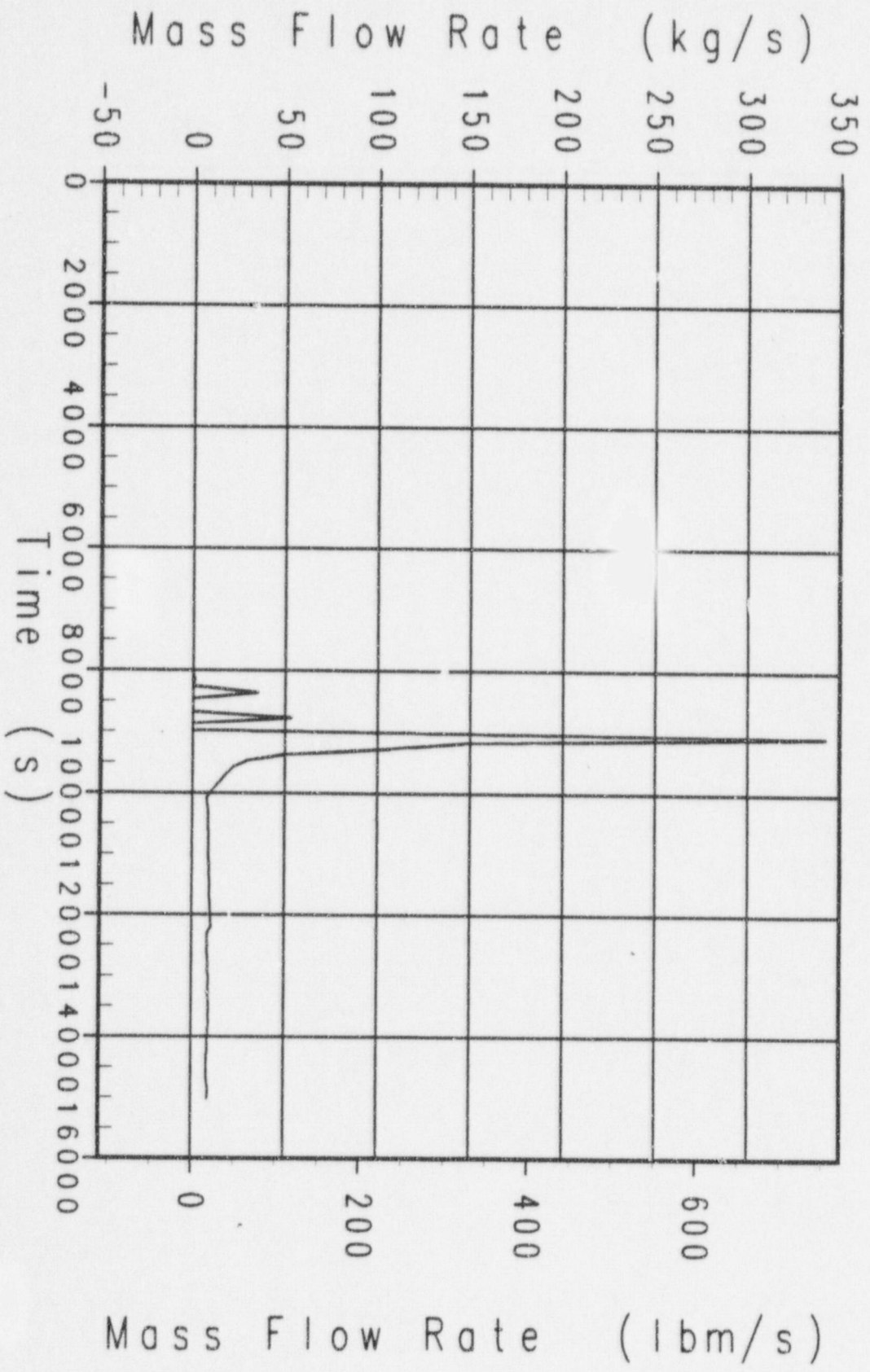

Case t5t AP600 Success Criteria MAAP4 Analysis
RCS Break Liquid Flowrate

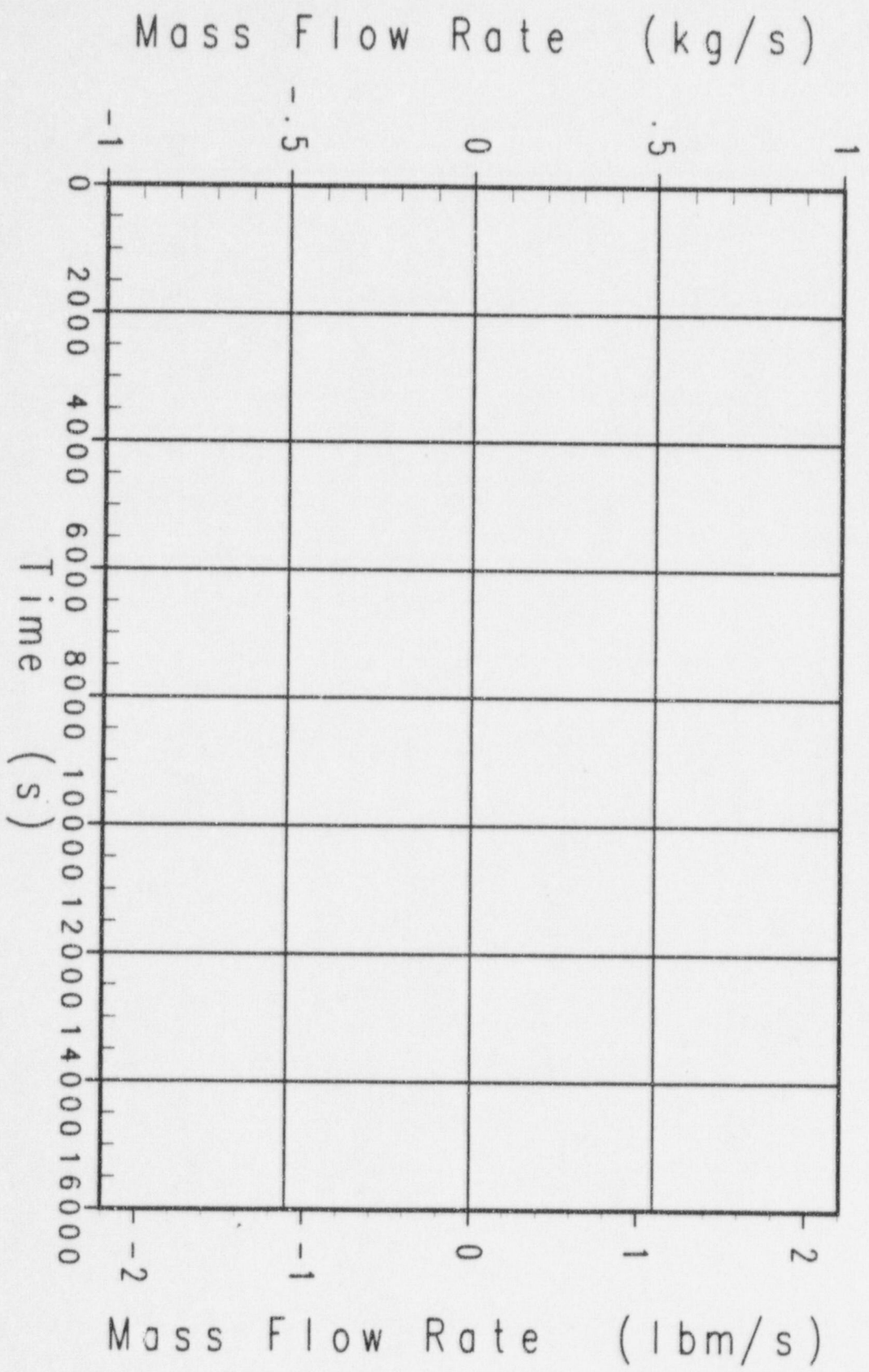

Case 151 AP600 Success Criteria MAA4 Analysis
ADS Stage 4 Liquid Flowrate

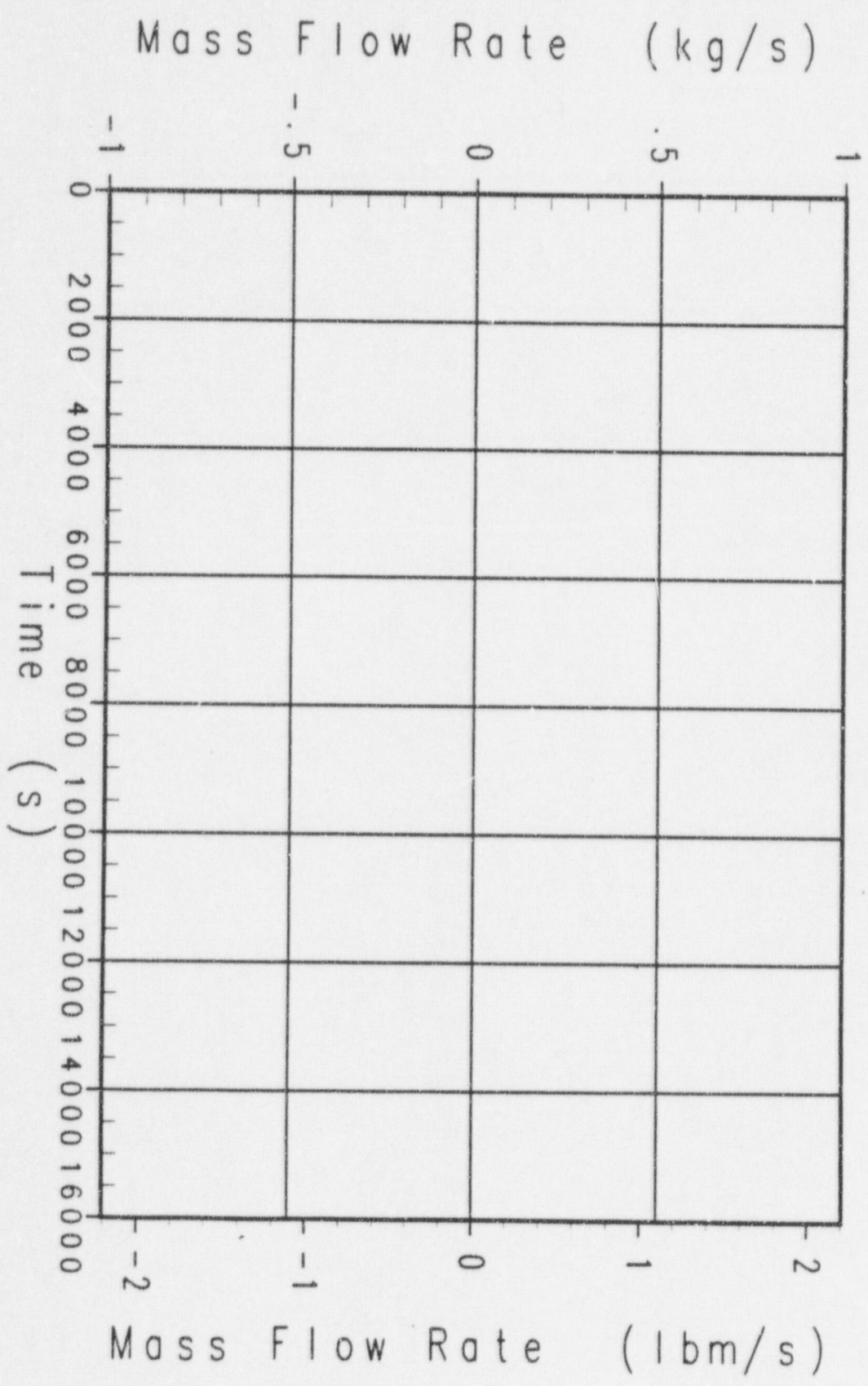

Case t5t AP600 Success Criteria MAMP4 Analysis
IRWST Injection Flowrate (neg. means into RCS)

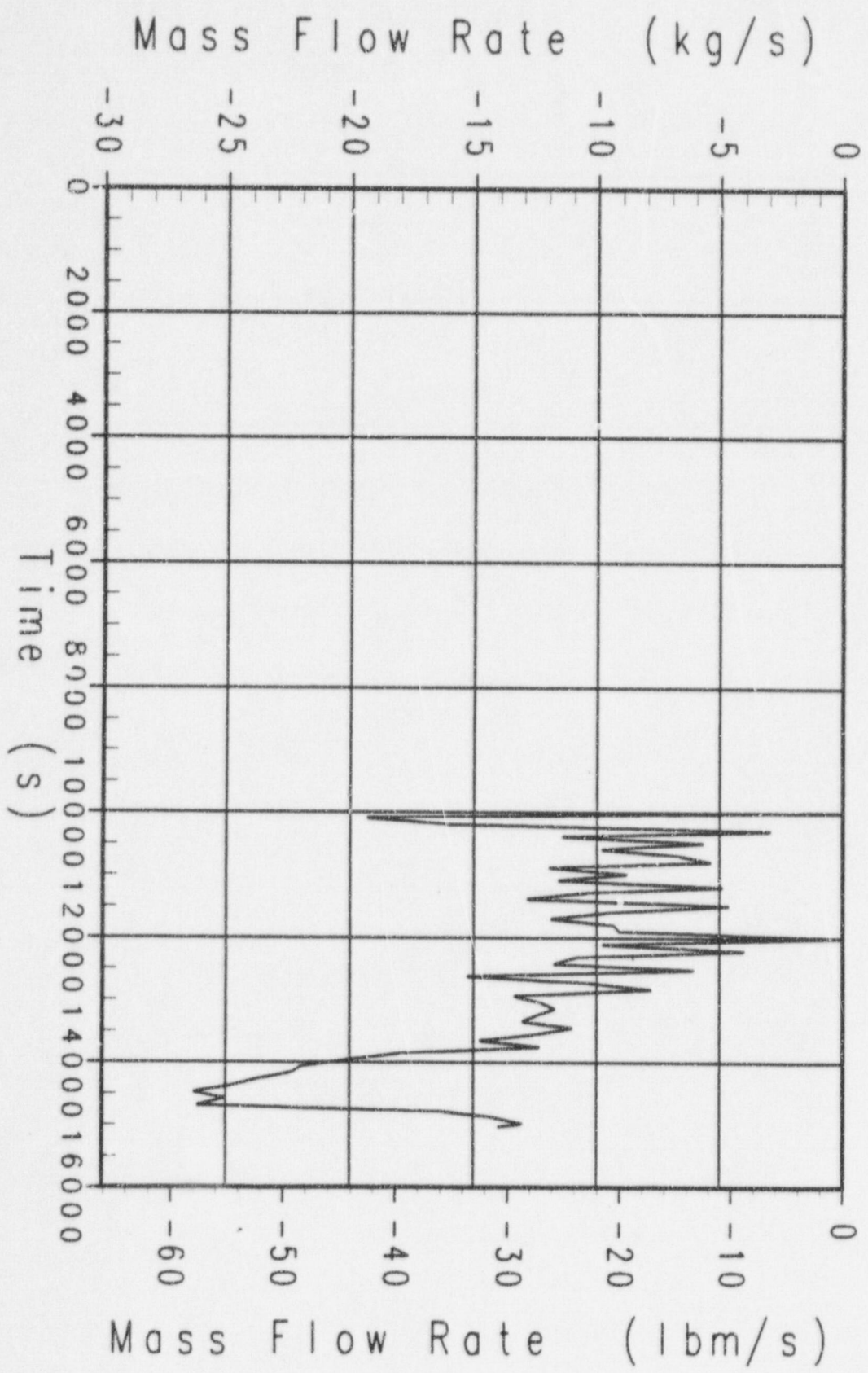

Case t5t AP600 Success Criteria MAAP4 Analysis
CMT-1 Injection Flowrate

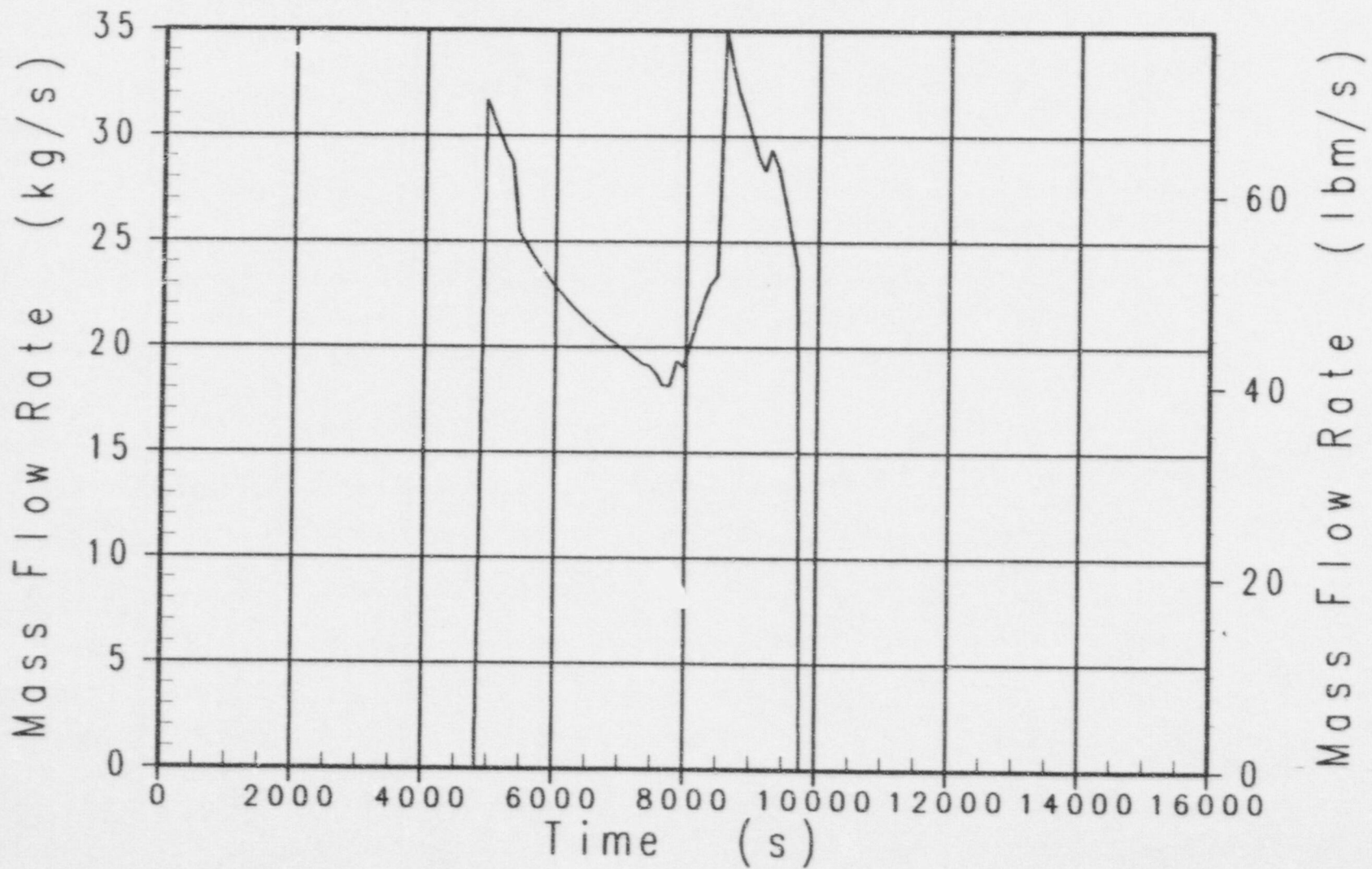

Case 15t AP600 Success Criteria MAAp4 Analysis
Safety Valve and ADS Stages 1-3 Liquid Flowrate

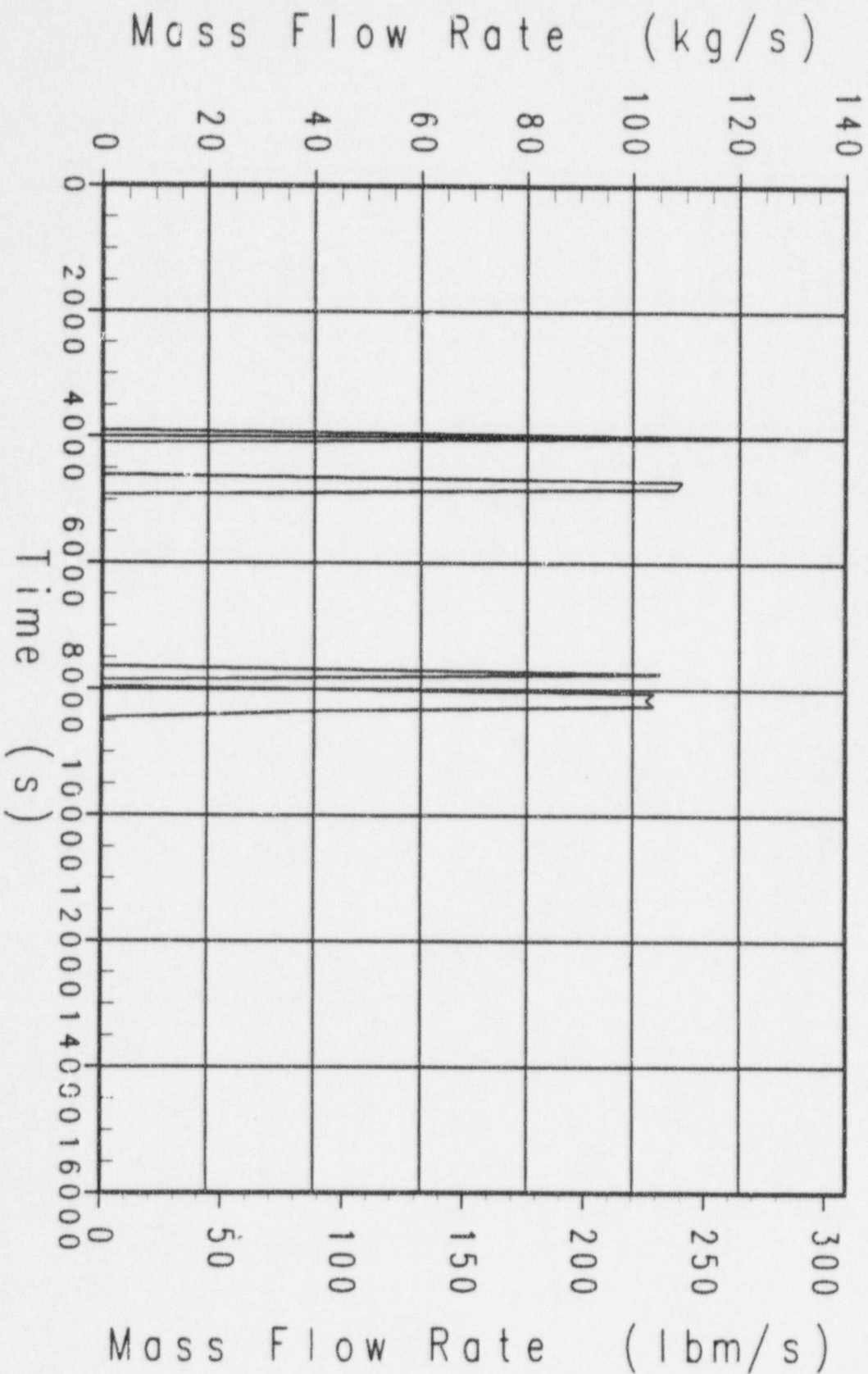

Case 15t AP600 Success Criteria MAAP4 Analysis
CMT-1 Water Level

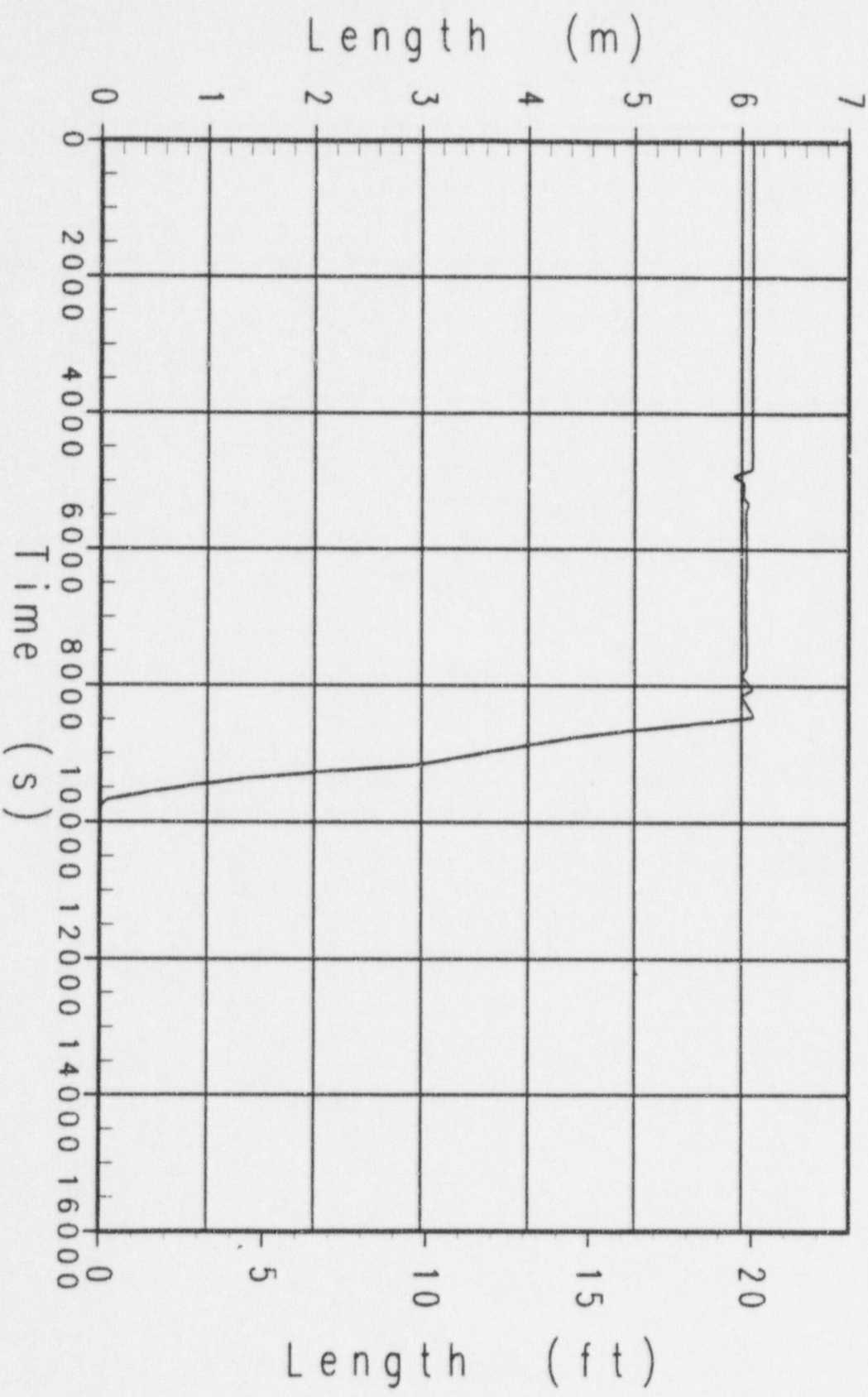

Case t5t AP600 Success Criteria MAAP4 Analysis
Pressurizer Water Level (From Pzr Bottom)

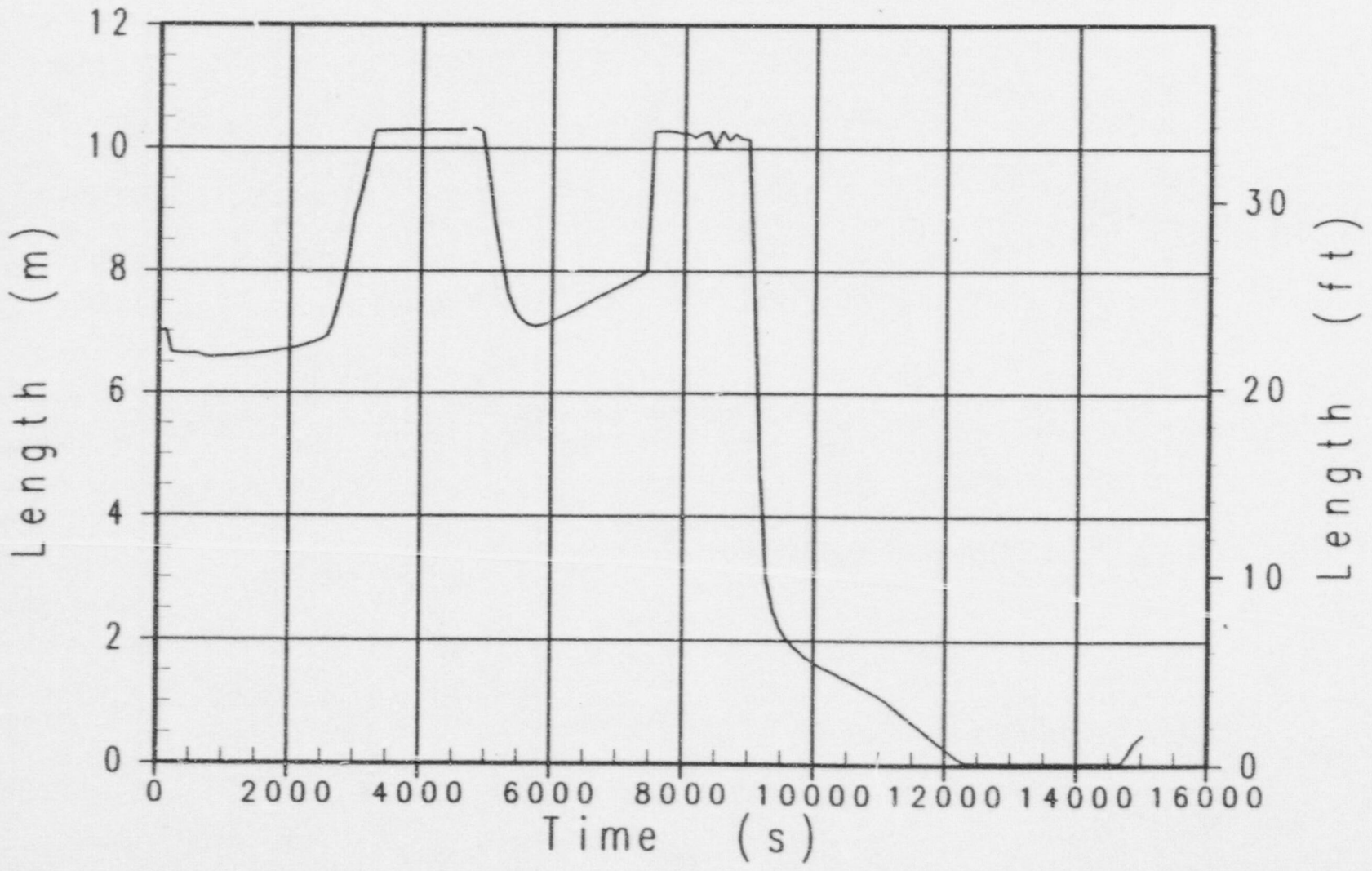

Case t9e AP600 Success Criteria MAAP4 Analysis
Broken Loop Steam Generator Pressure

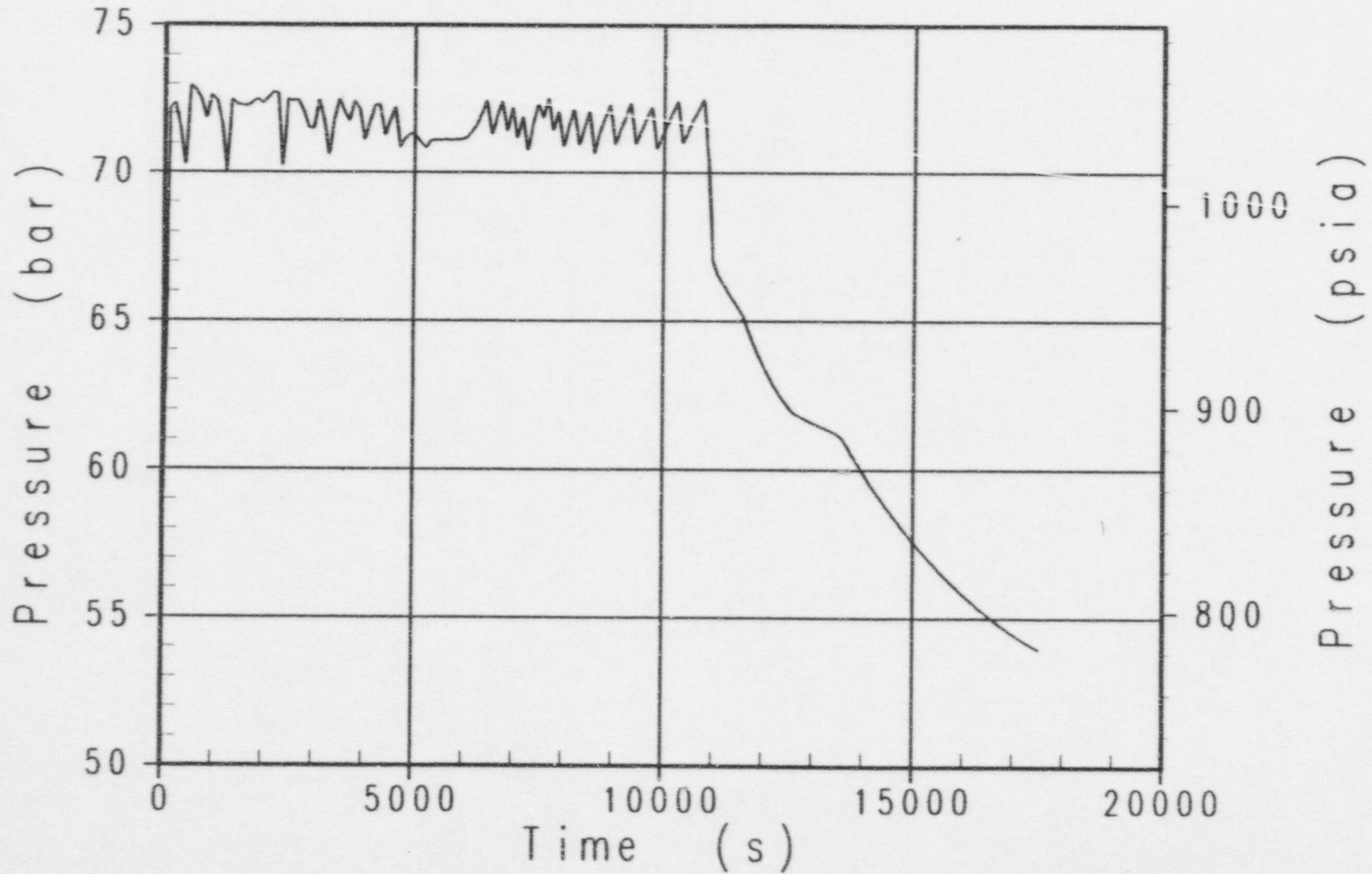

Case t9e AP600 Success Criteria MAAP4 Analysis
Primary System Pressure

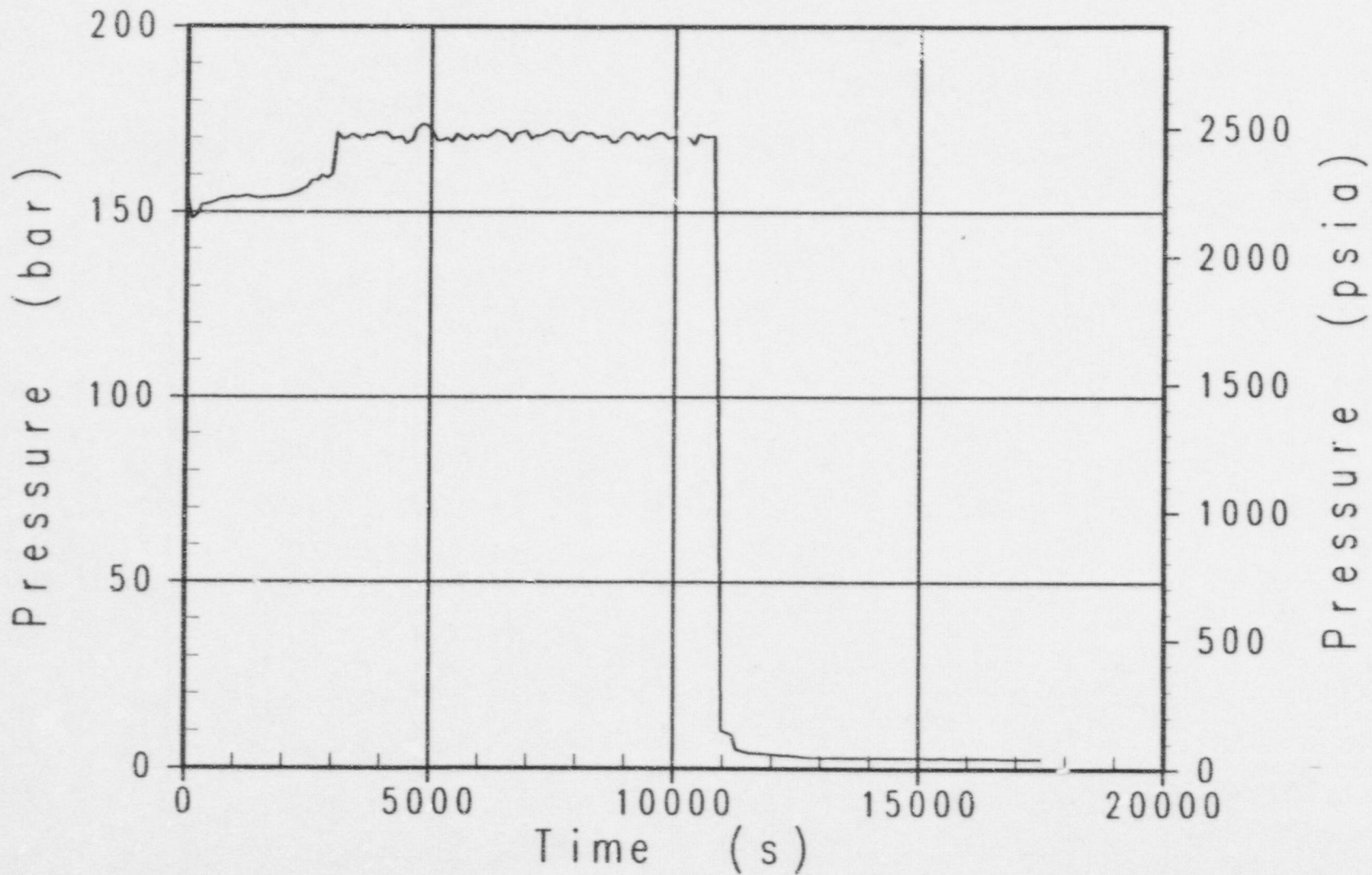

Case t9e AP600 Success Criteria MAAP4 Analysis
Containment Pressure

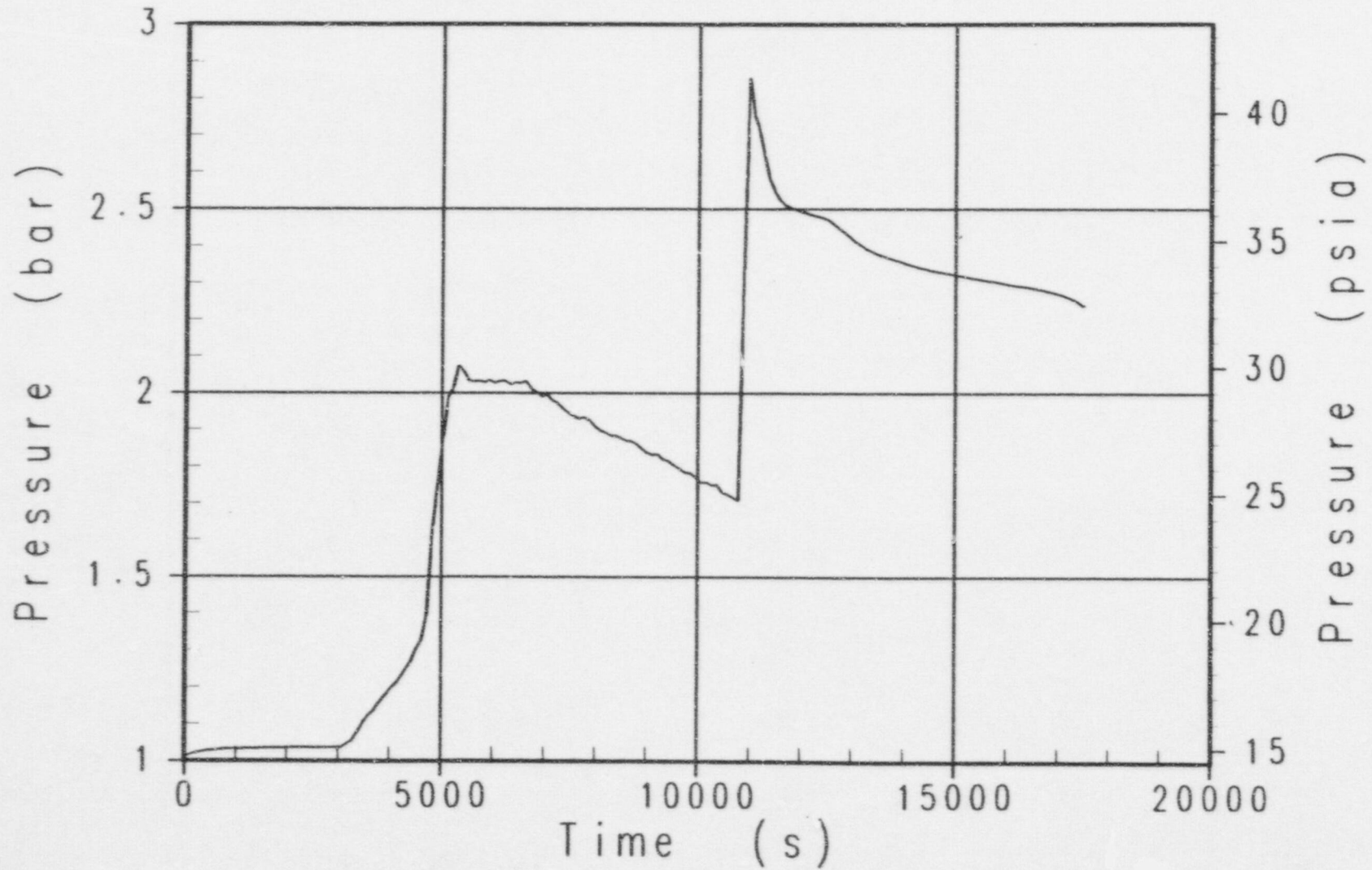

Case t9e AP600 Success Criteria MAAP4 Analysis
Unbroken Loop Steam Generator Pressure

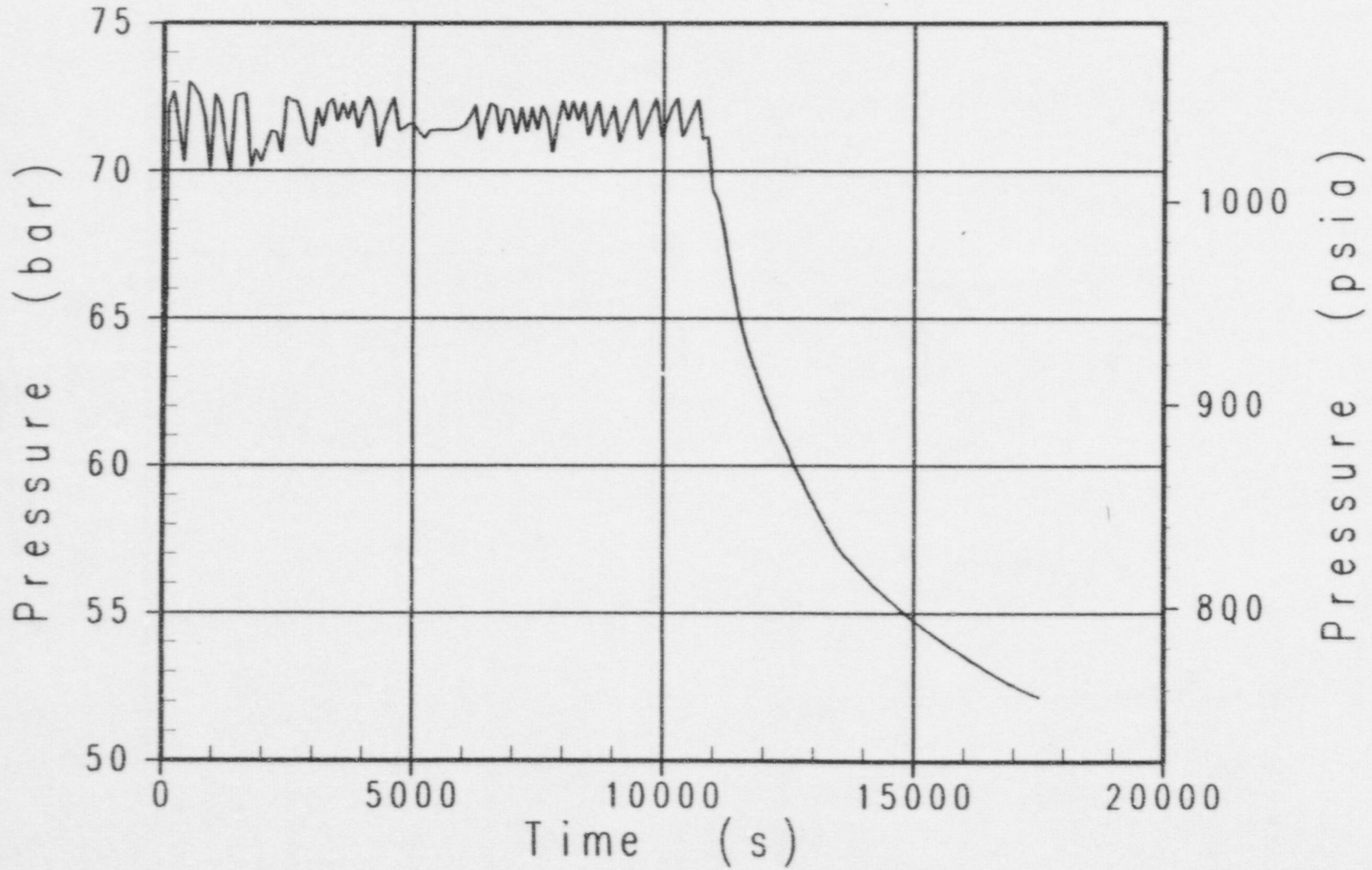

Case t9e AP600 Success Criteria MAAP4 Analysis
Decay Power

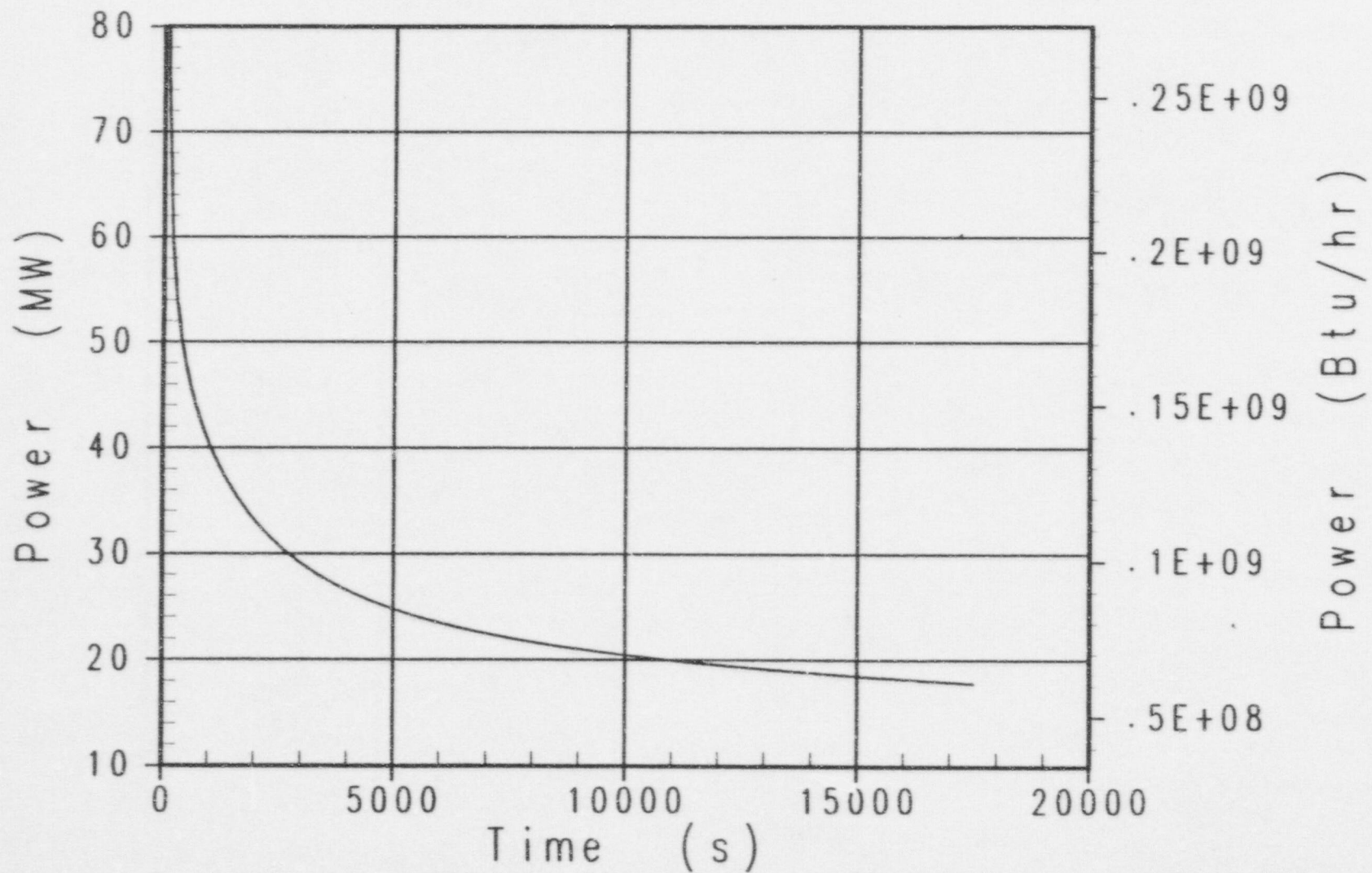

Case t9e AP600 Success Criteria MAAP4 Analysis
PRHR Heat Removal Rate

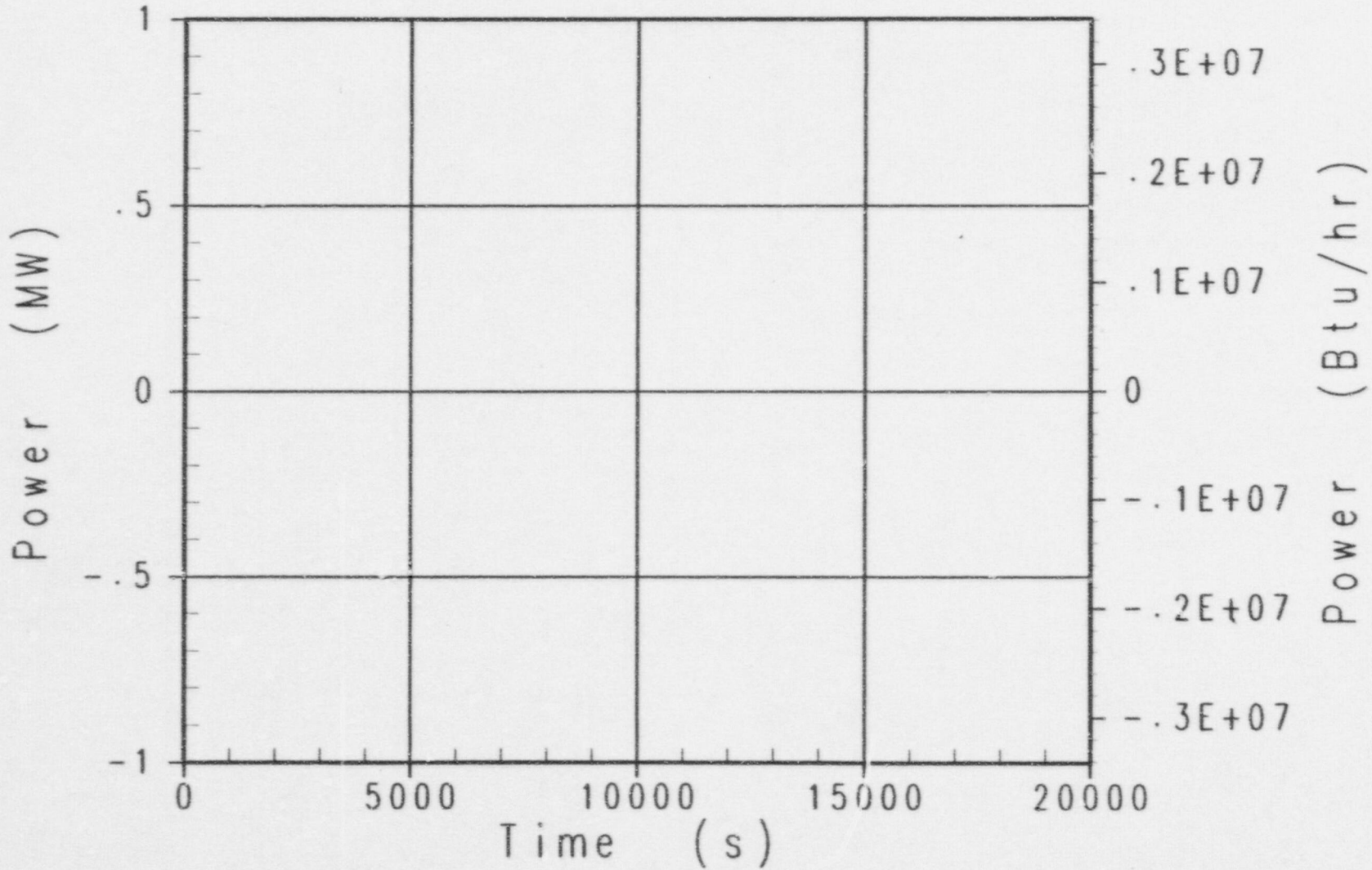

Case 19e AP600 Success Criteria MAAP4 Analysis
Peak Temperature in the Core

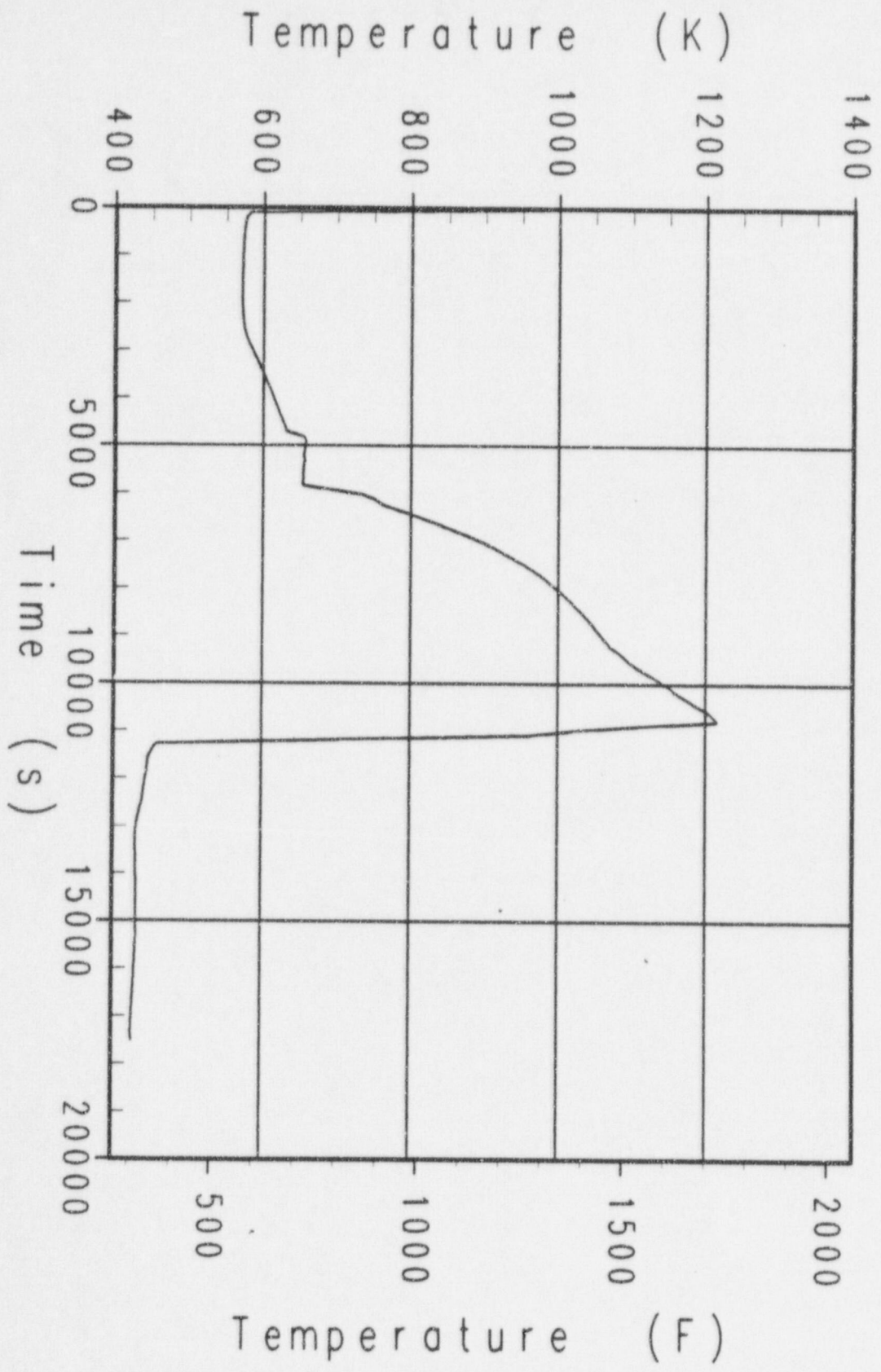

Case t9e AP600 Success Criteria MAAP4 Analysis
Cold Leg Water Temperature



Case t9e AP600 Success Criteria MAAP4 Analysis
Core Water Temperature

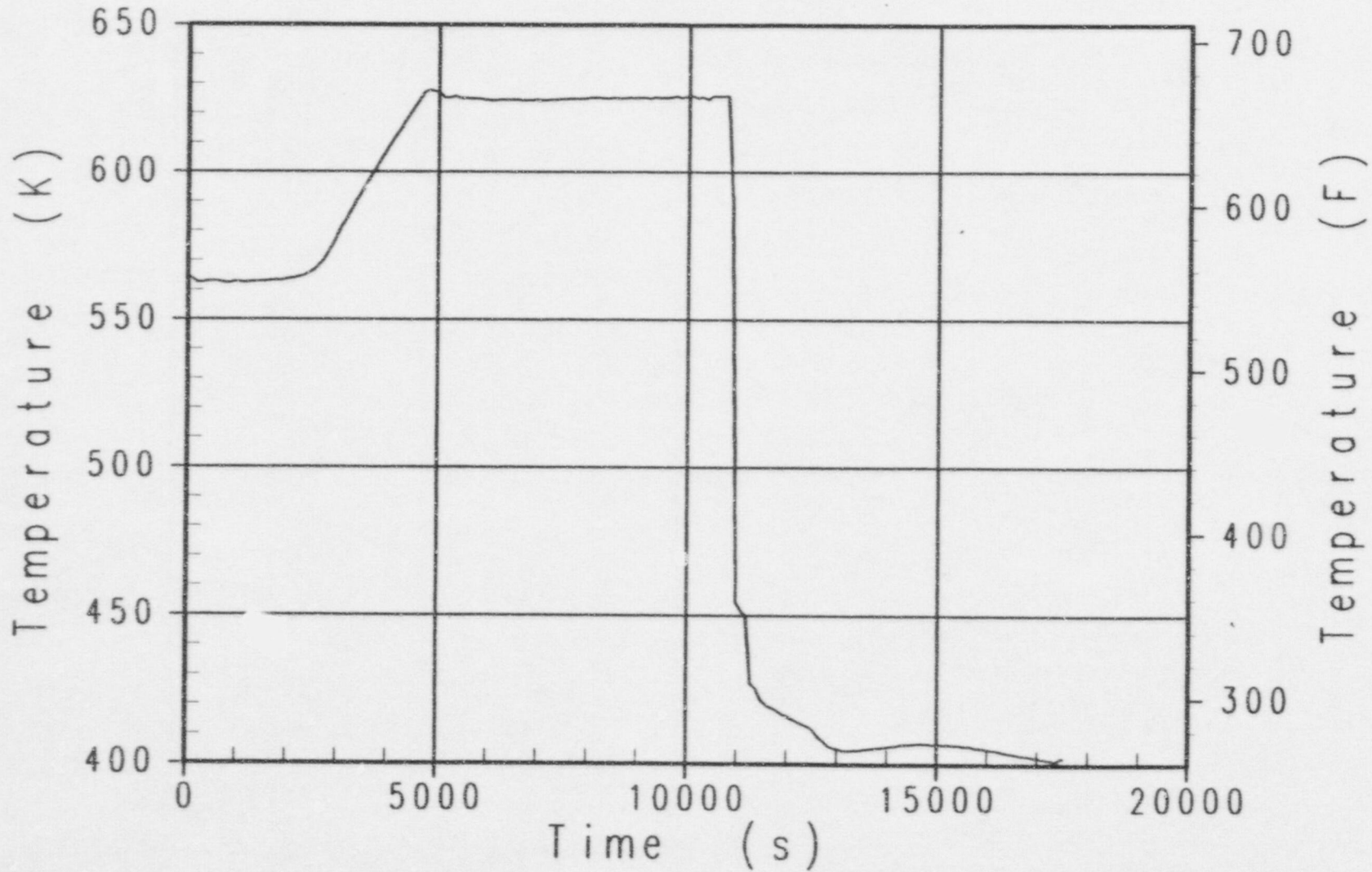

Case t9e AP600 Success Criteria MAAP4 Analysis
RPV Downcomer Water Temperature

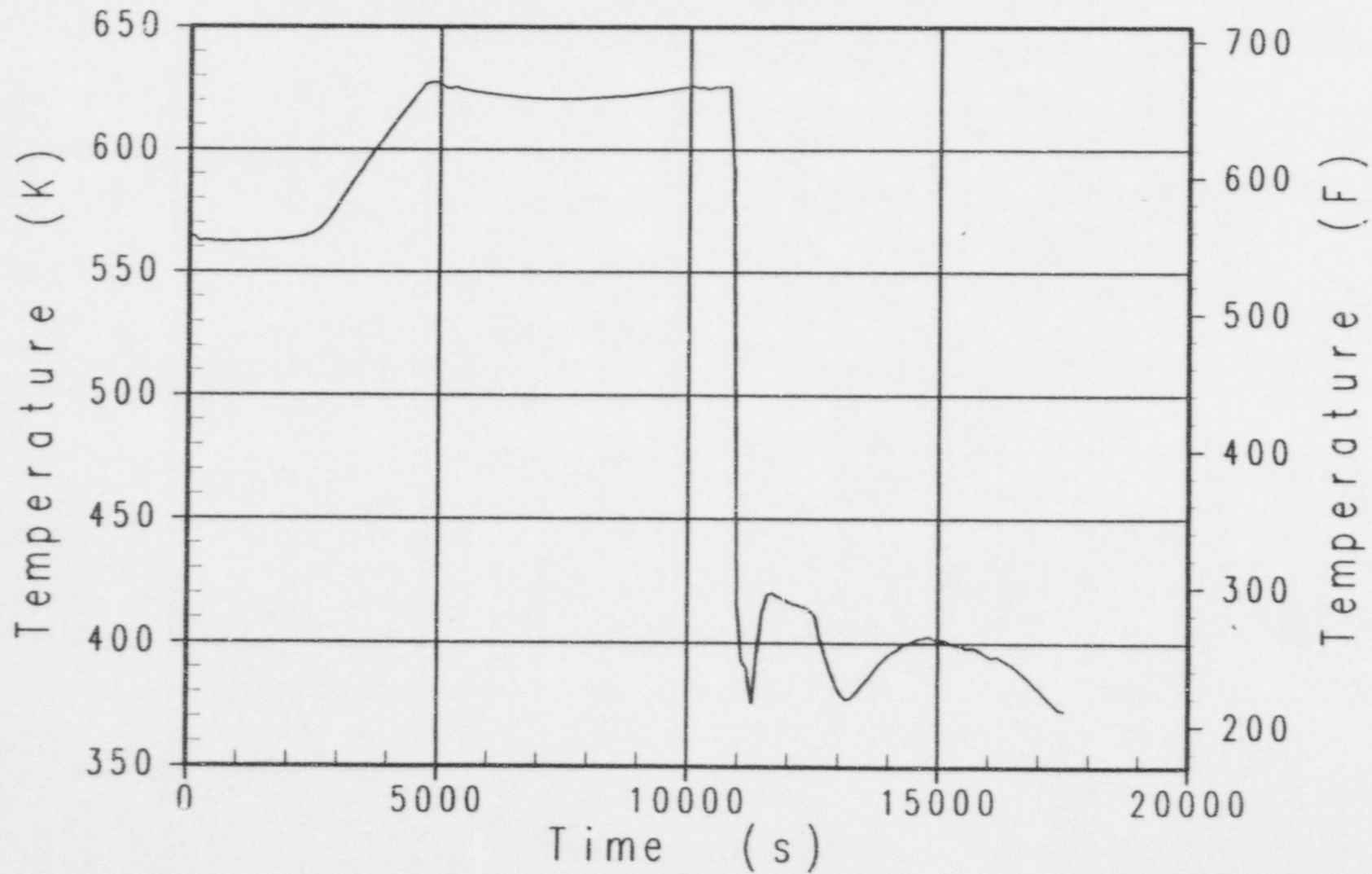

Case t9e AP600 Success Criteria MAAP4 Analysis
IRWST Water Temperature

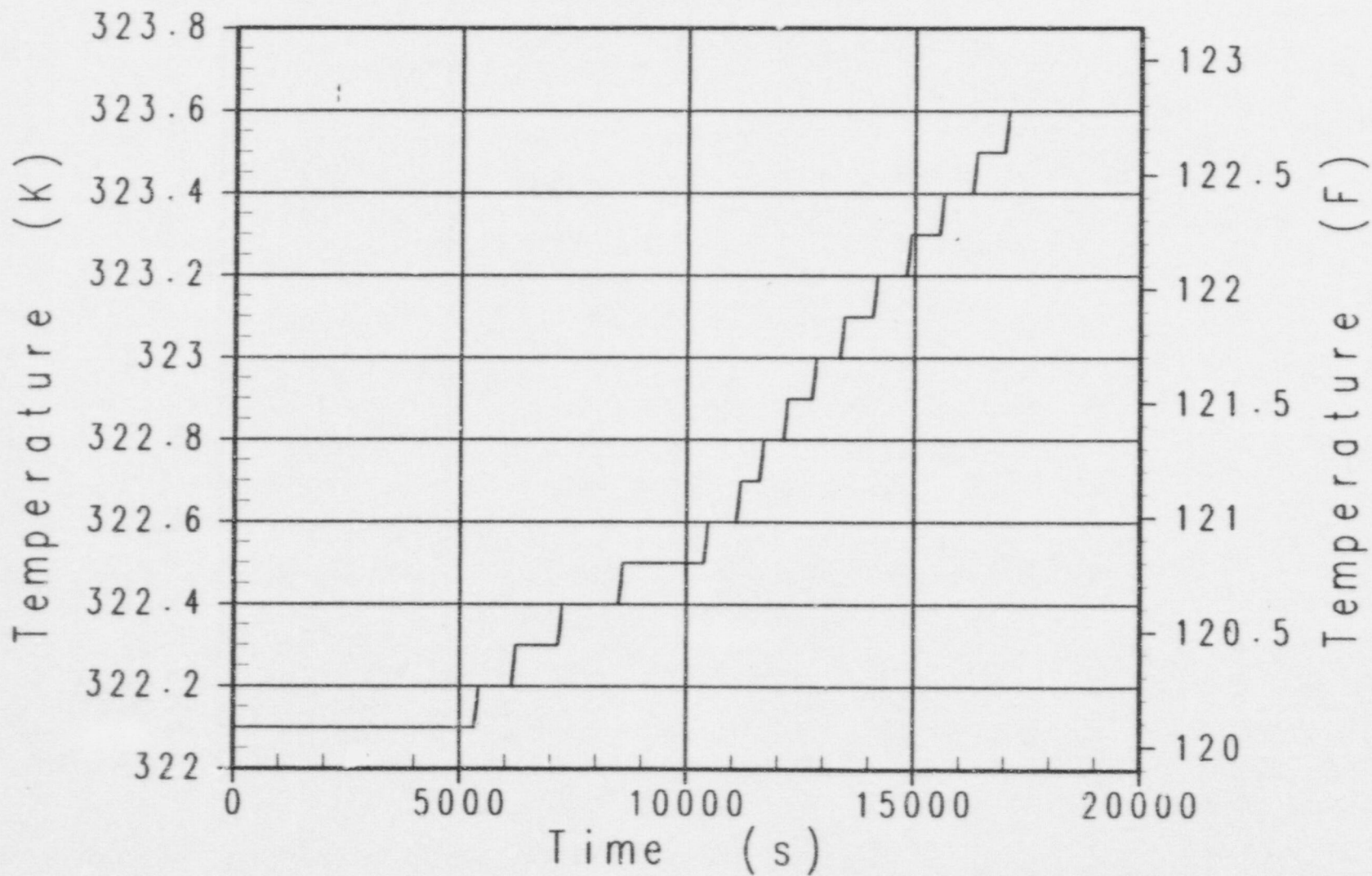

Case t9e AP600 Success Criteria MAAP4 Analysis
Accumulator and NRHR Injection Flowrate

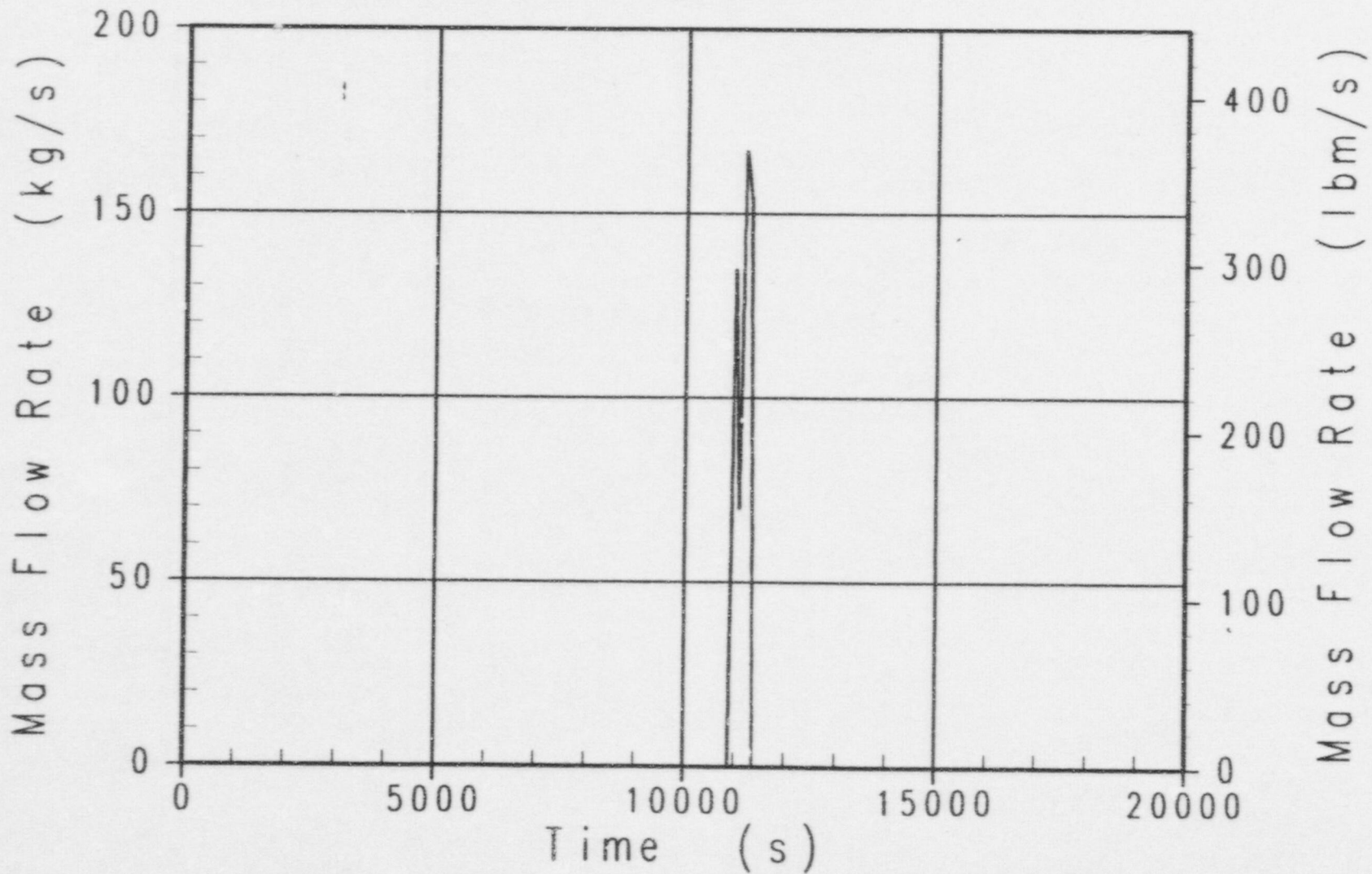

Case t9e AP600 Success Criteria MAAP4 Analysis
RCS Break Gas Flowrate

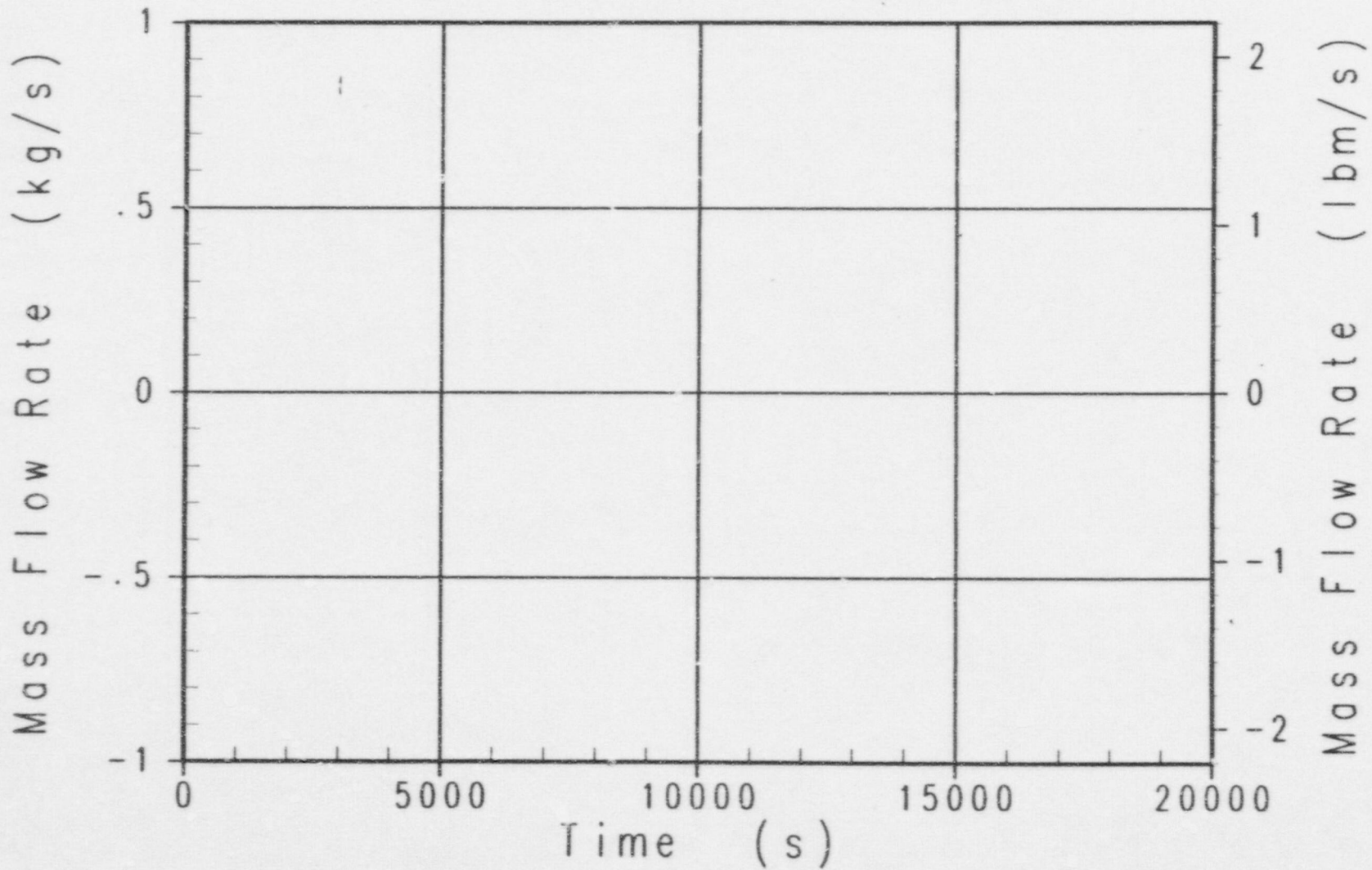

Case t9e AP600 Success Criteria MAAP4 Analysis
ADS Stage 4 Gas Flowrate

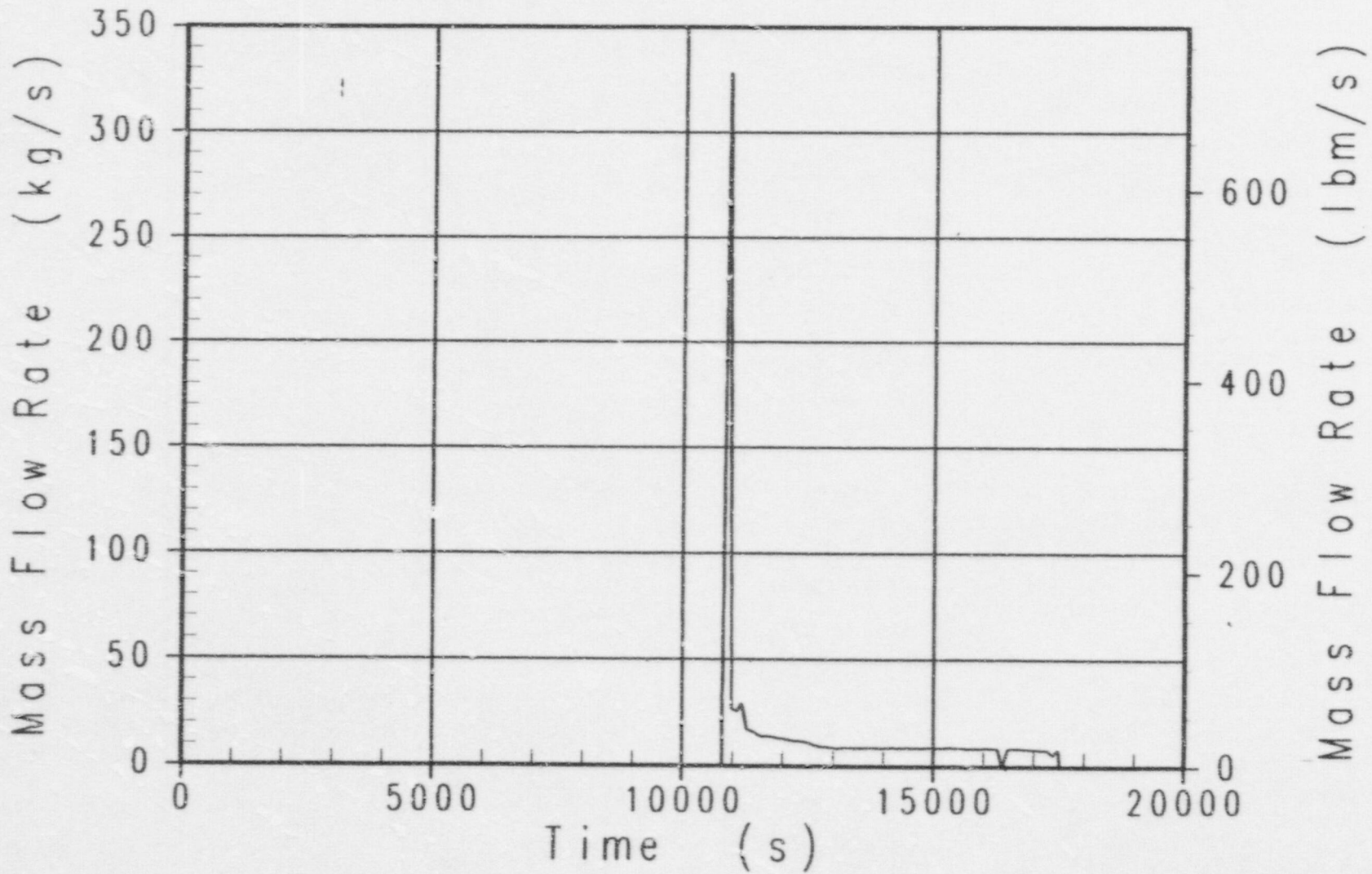

Case t9e AP600 Success Criteria MAAP4 Analysis
Safety Valve and ADS Stages 1-3 Gas Flowrate

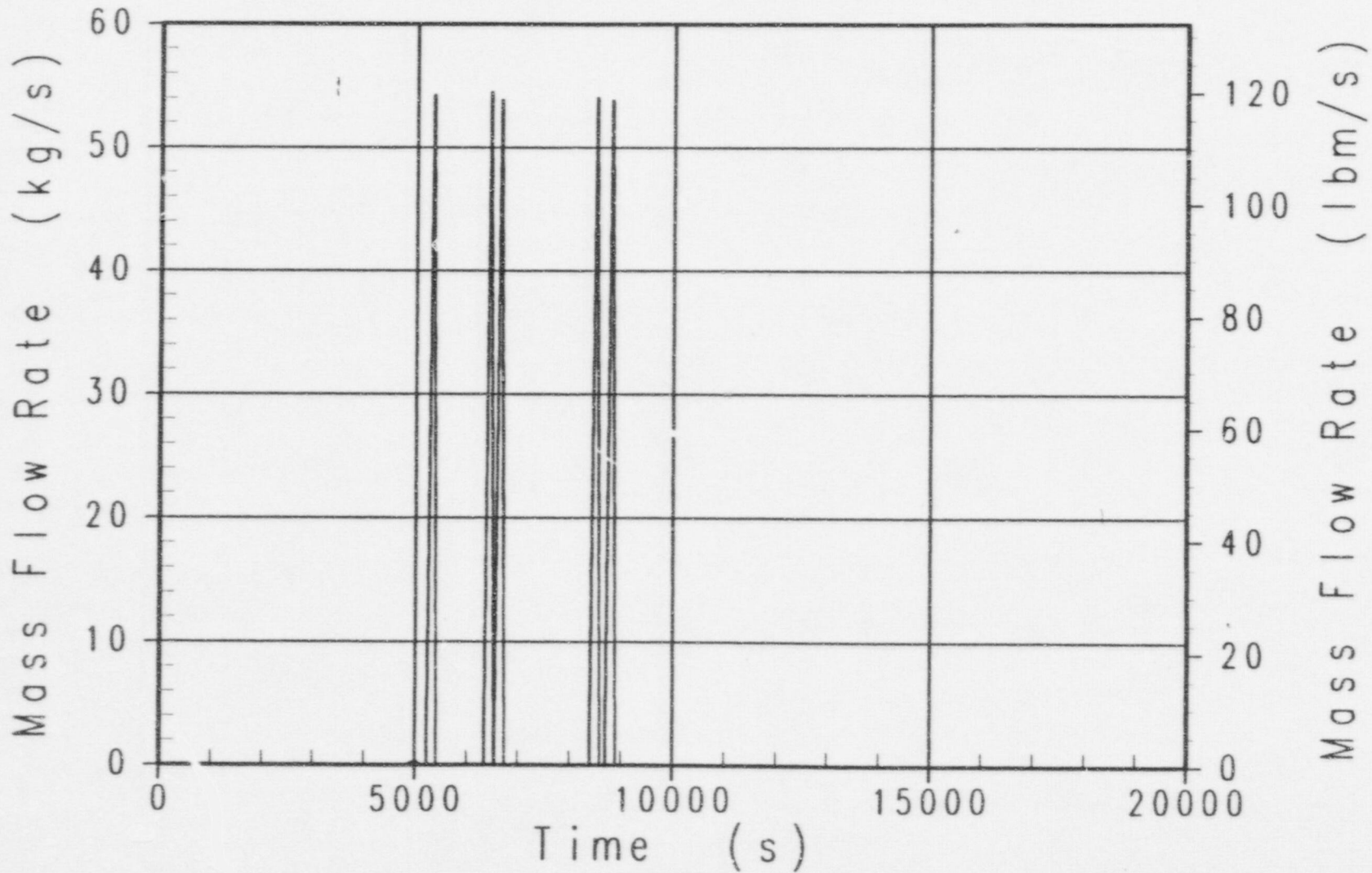

Case t9e AP600 Success Criteria MAAP4 Analysis
RCS Break Liquid Flowrate

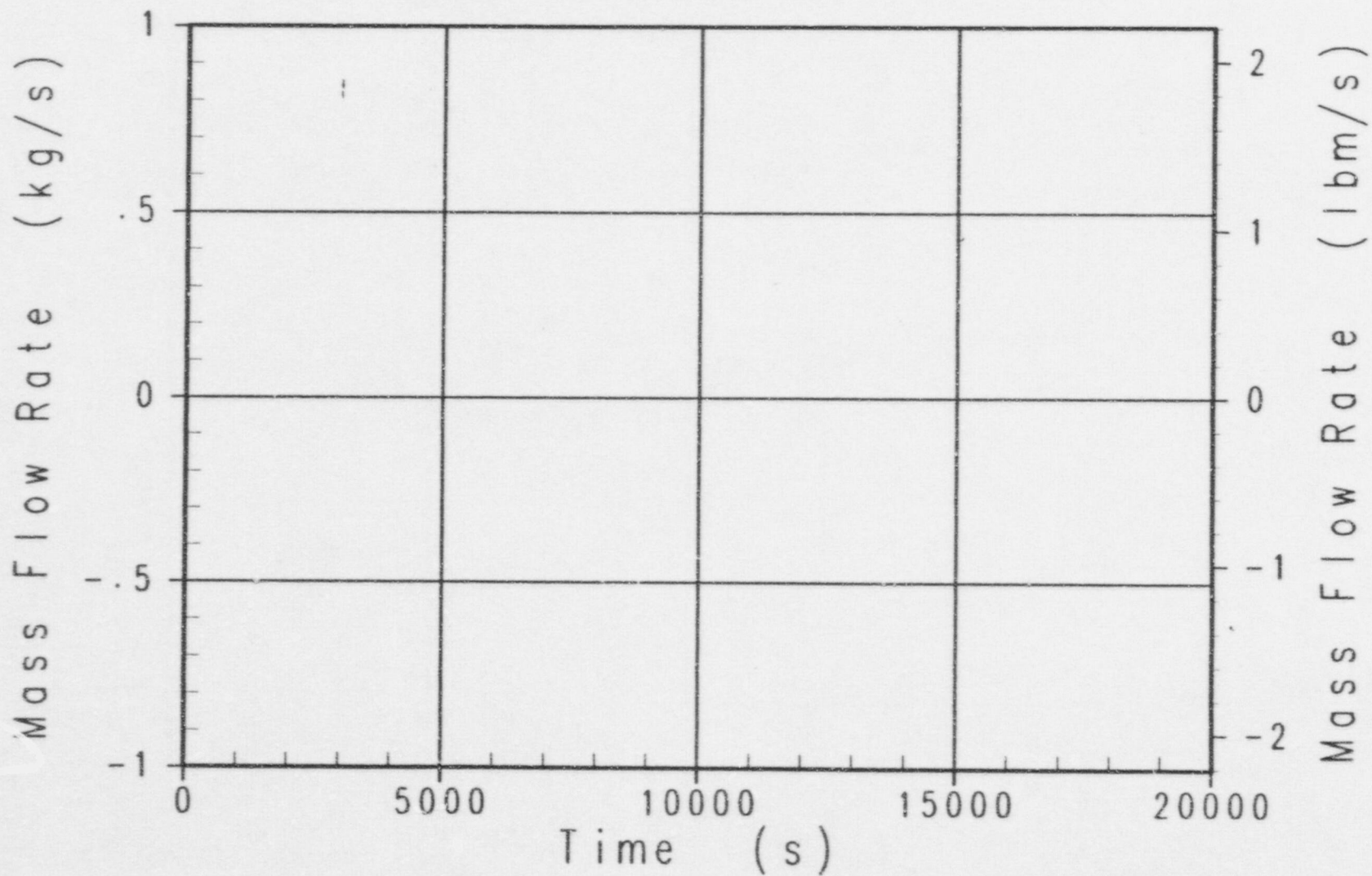

Case 19e AP600 Success Criteria MAAP4 Analysis
ADS Stage 4 Liquid Flowrate

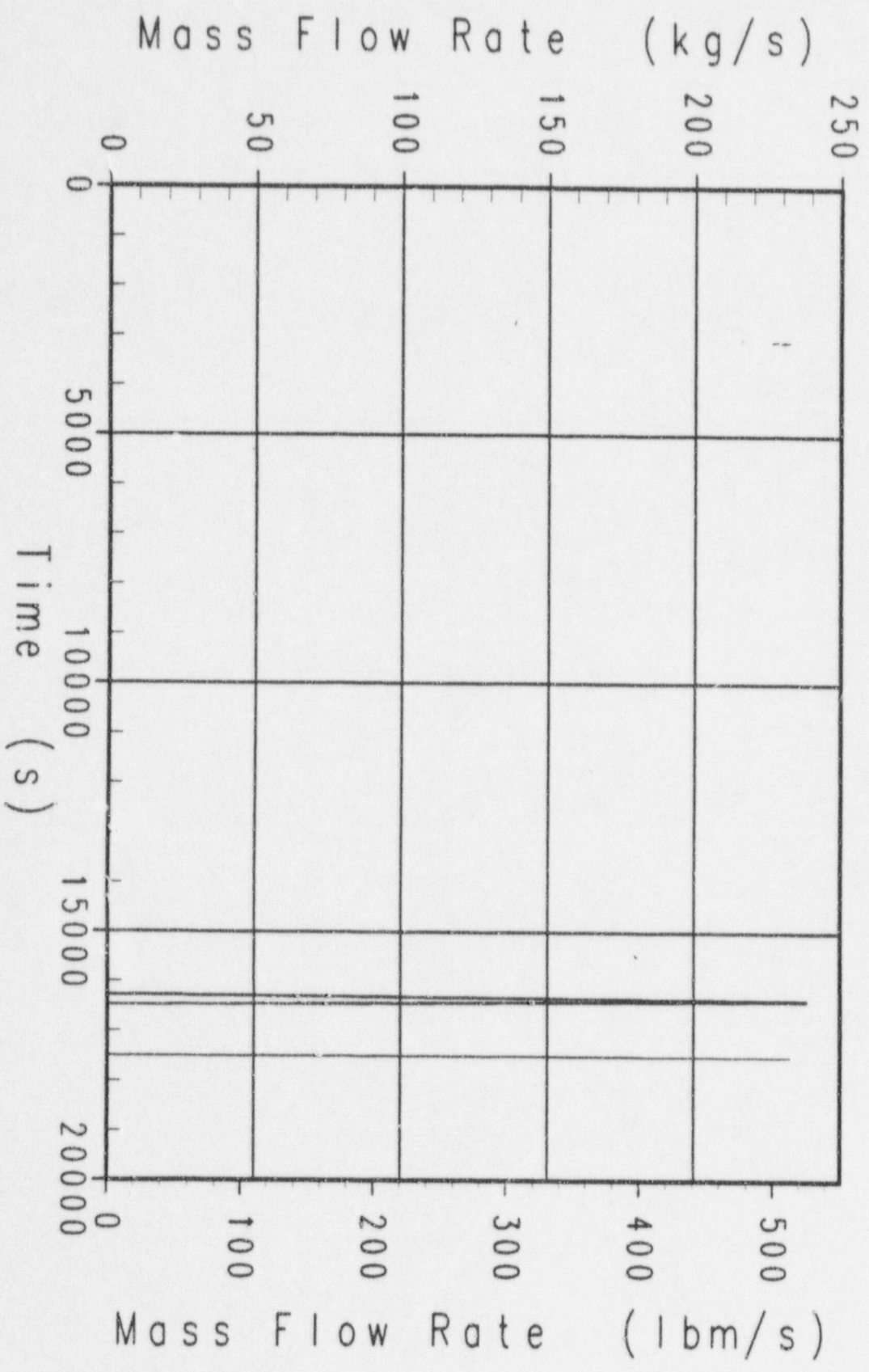

Case 19e AP600 Success Criteria MAAP4 Analysis
IRWST Injection Flowrate (neg. means into RCS)

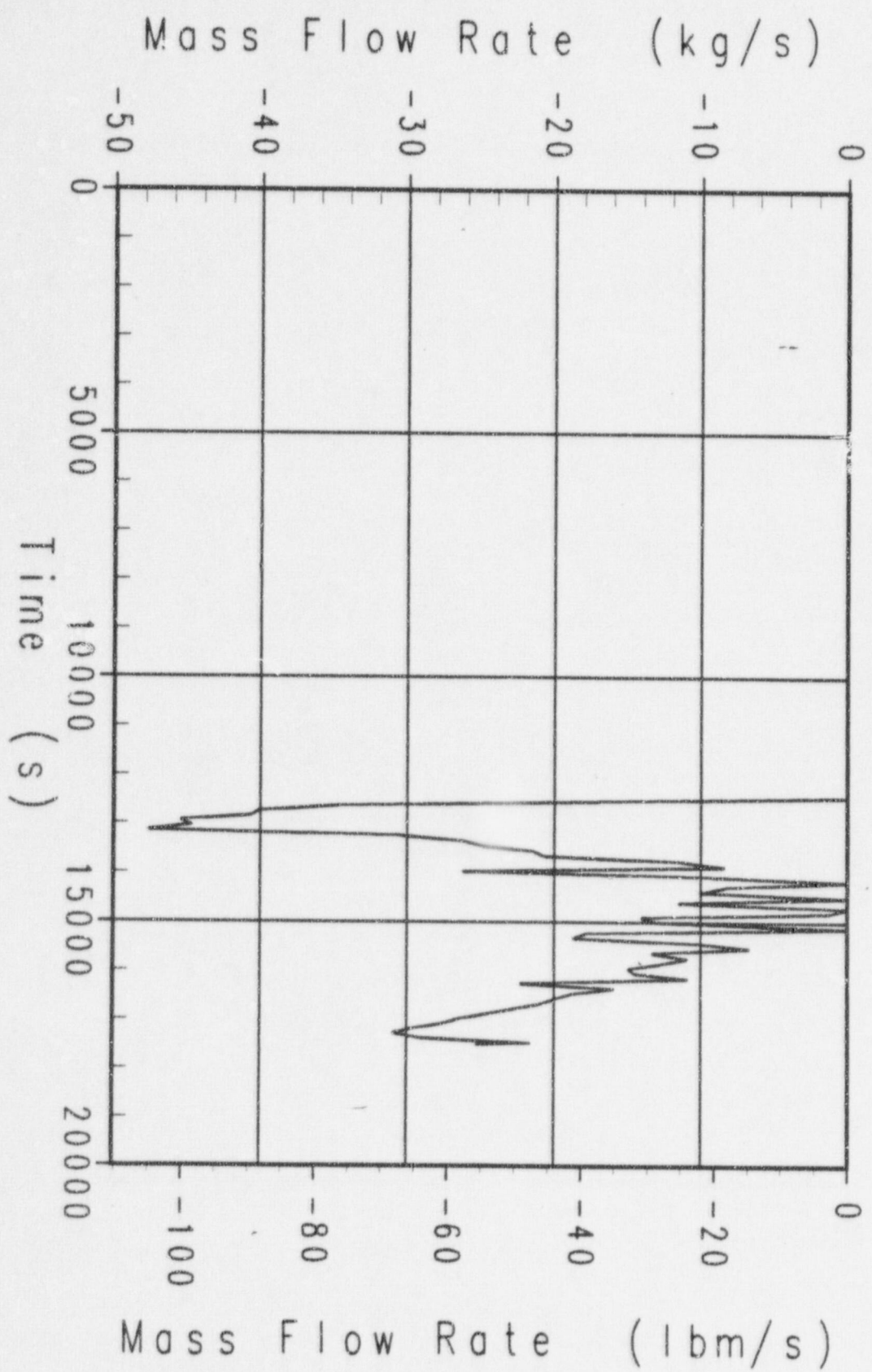

Case t9e AP600 Success Criteria MAAP4 Analysis
CMT-1 Injection Flowrate

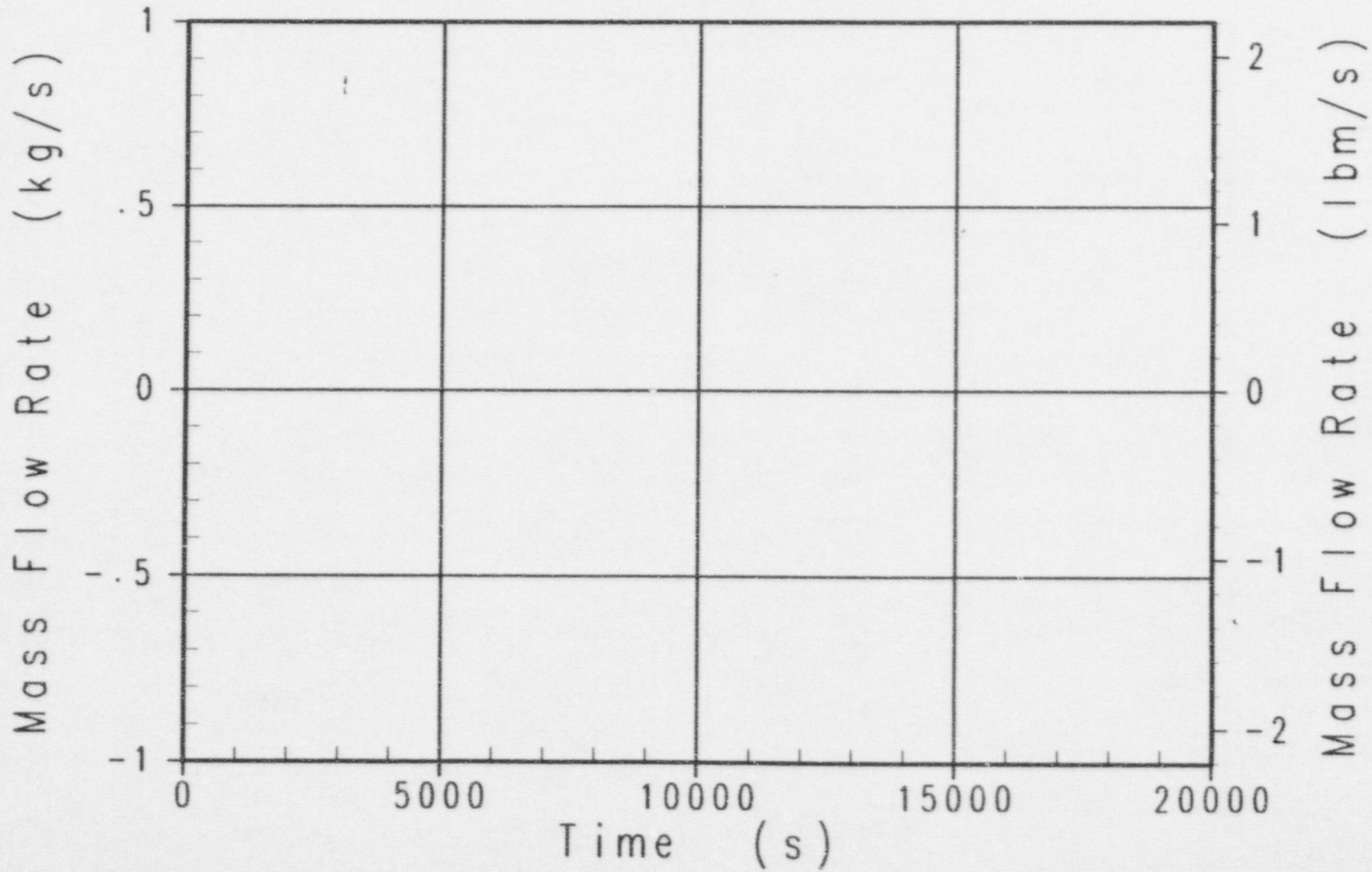

Case t9e AP600 Success Criteria MAAP4 Analysis
Safety Valve and ADS Stages 1-3 Liquid Flowrate

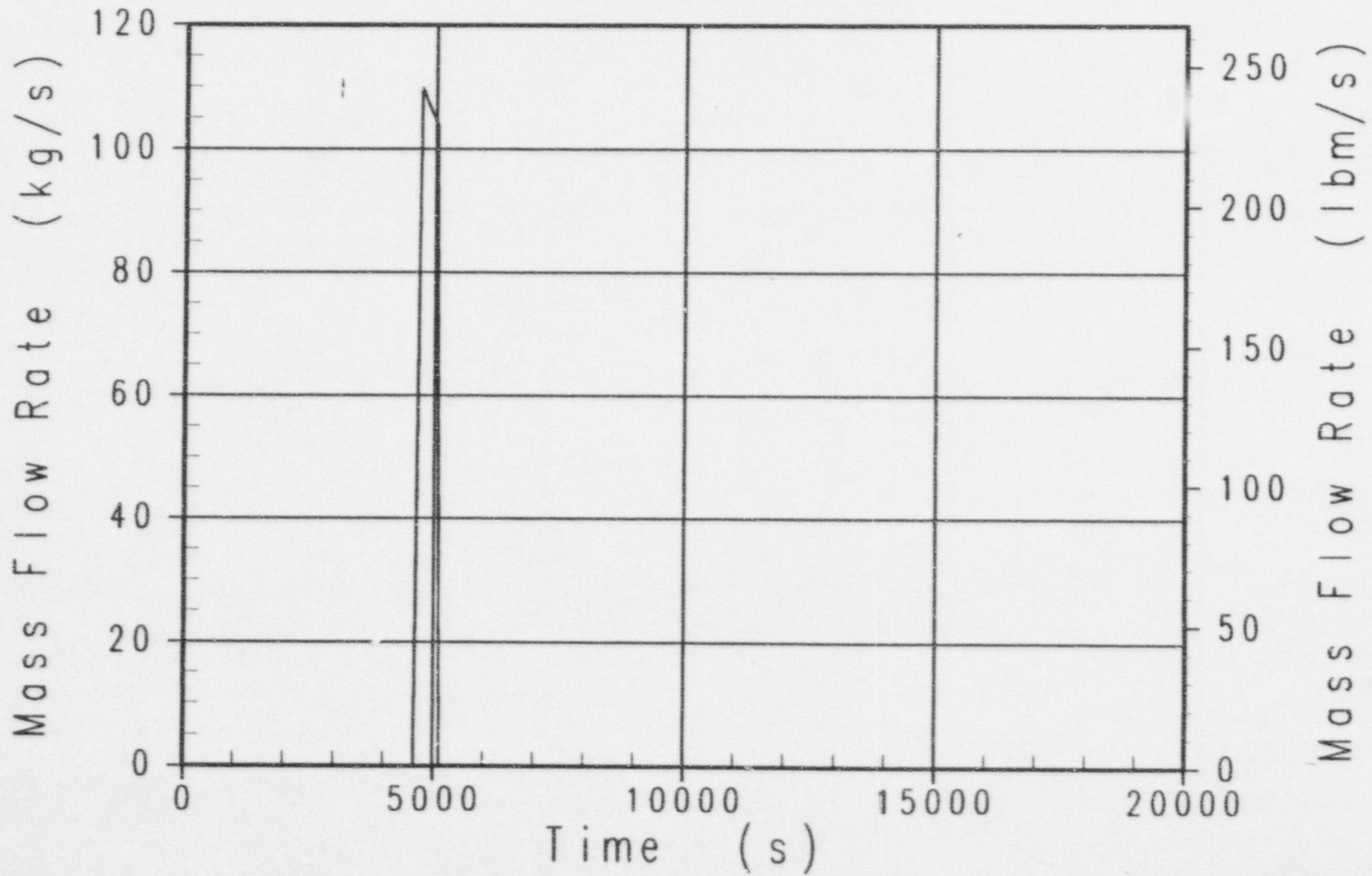

Case t9e AP600 Success Criteria MAAP4 Analysis
CMT-1 Water Level

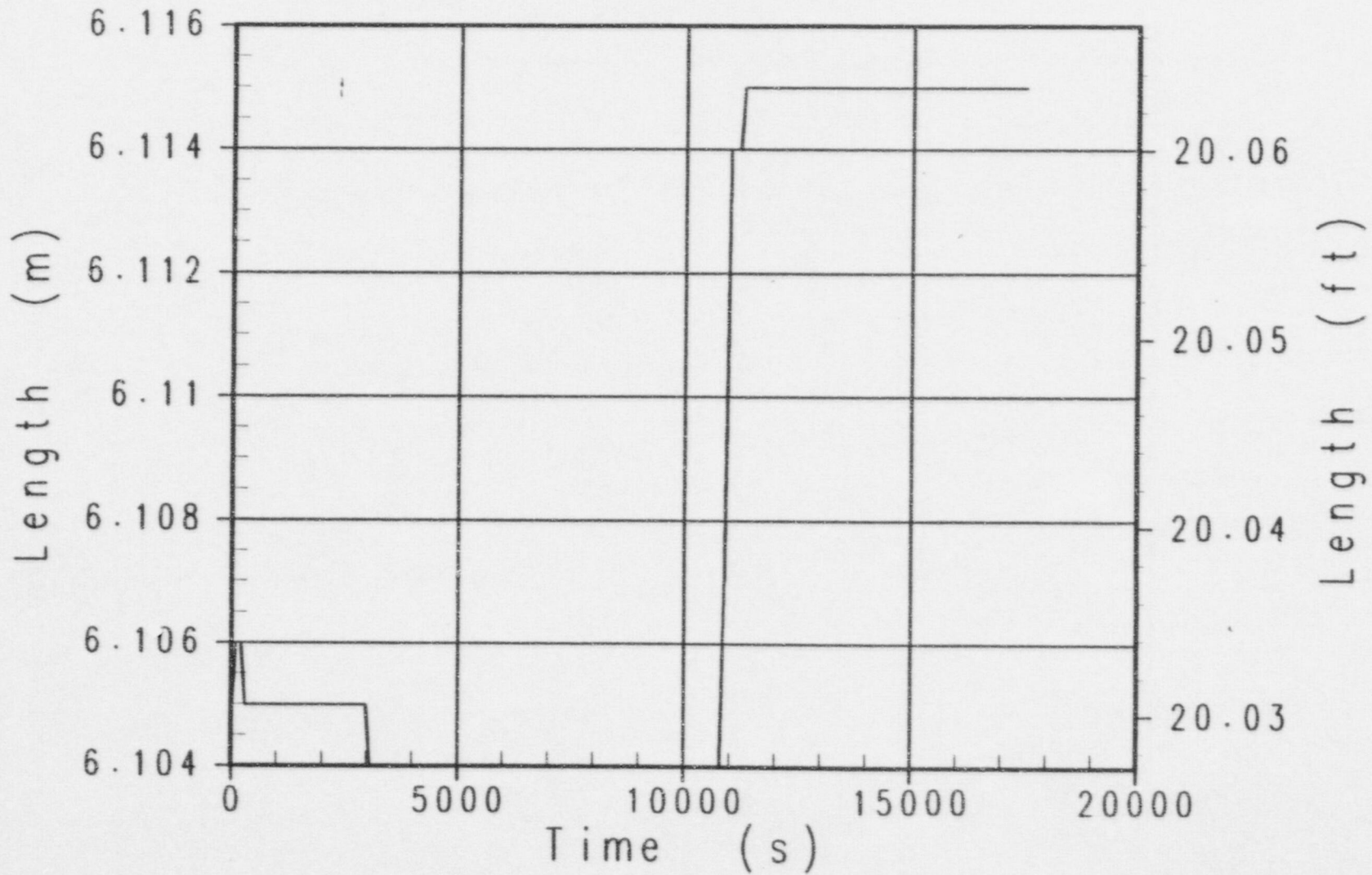

Case t9e AP600 Success Criteria MAAP4 Analysis
Pressurizer Water Level (From Pzr Bottom)

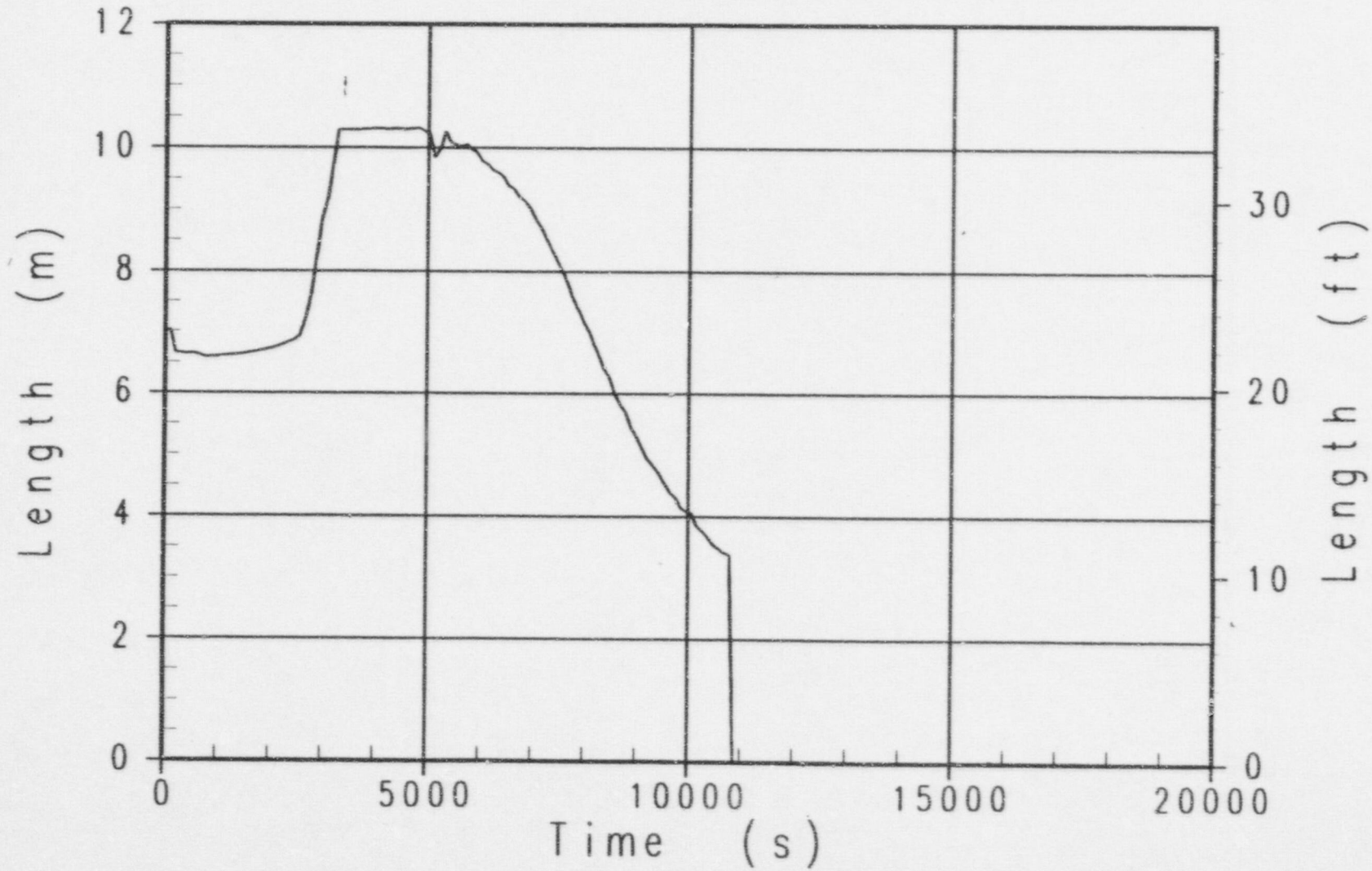

Case t110 AP600 Success Criteria MAAP4 Analysis
Broken Loop Steam Generator Pressure

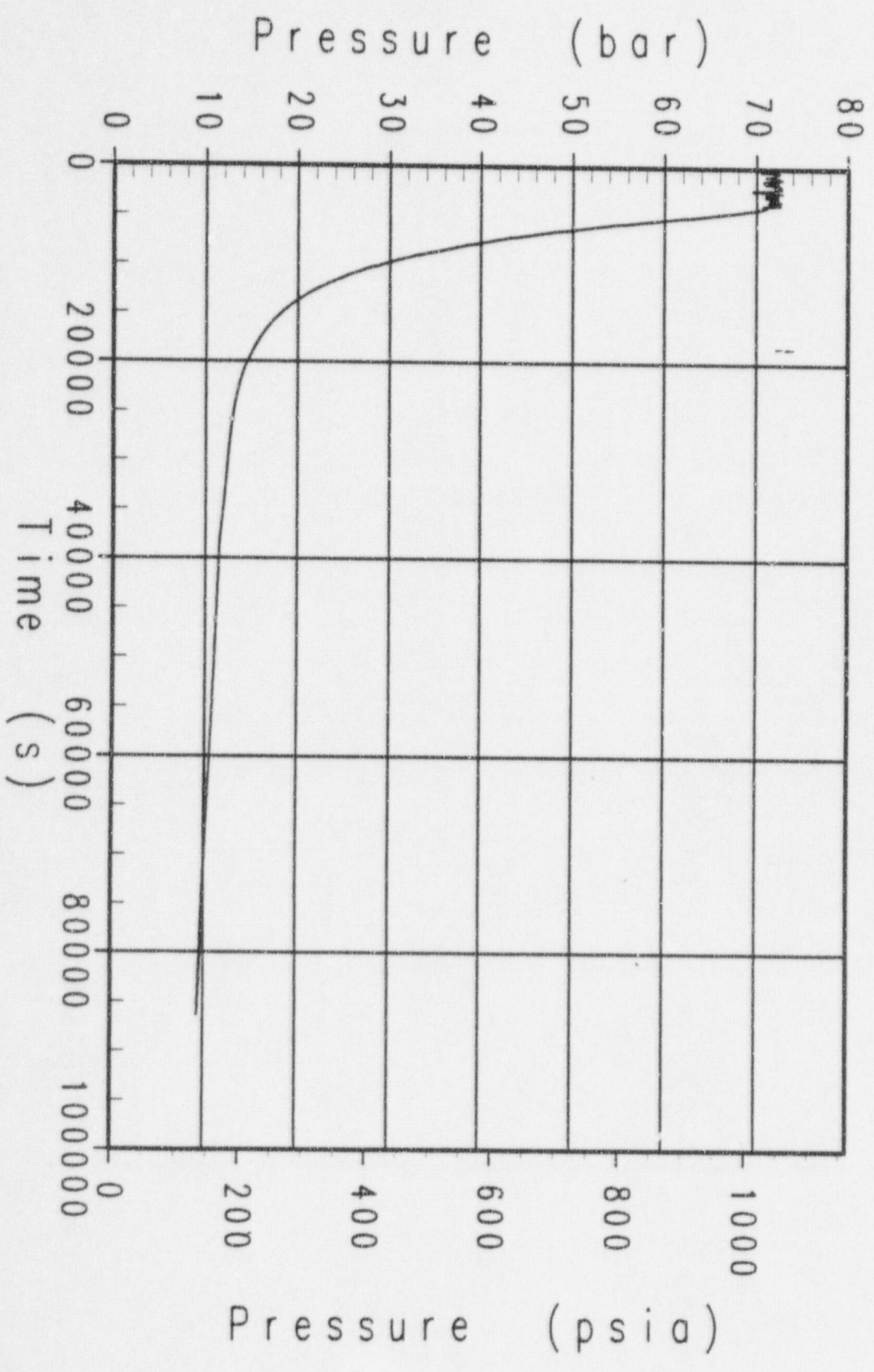

Case t10 AP600 Success Criteria MAAp4 Analysis
Primary System Pressure

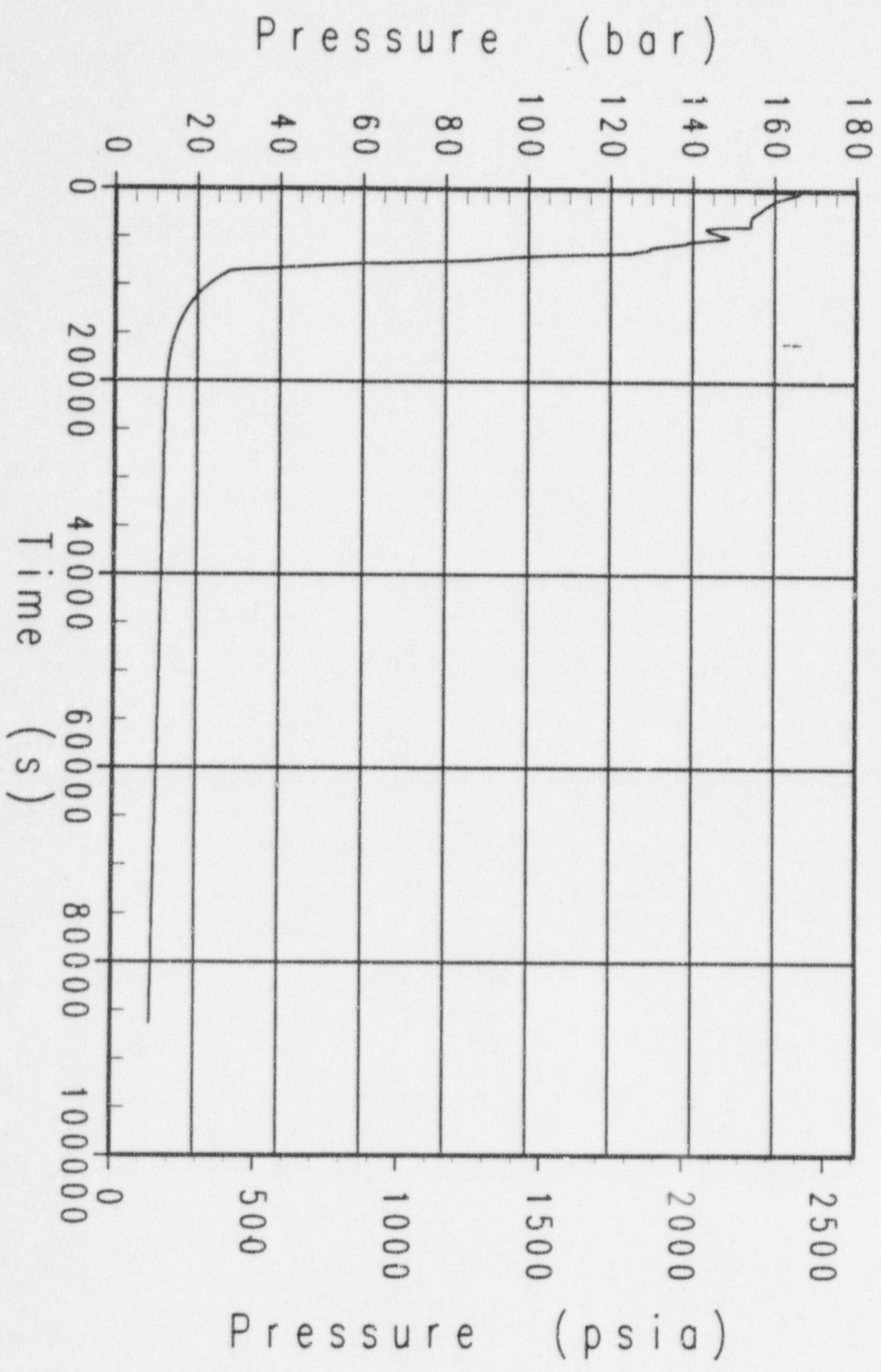

Case t10 AP600 Success Criteria MAAP4 Analysis
Containment Pressure

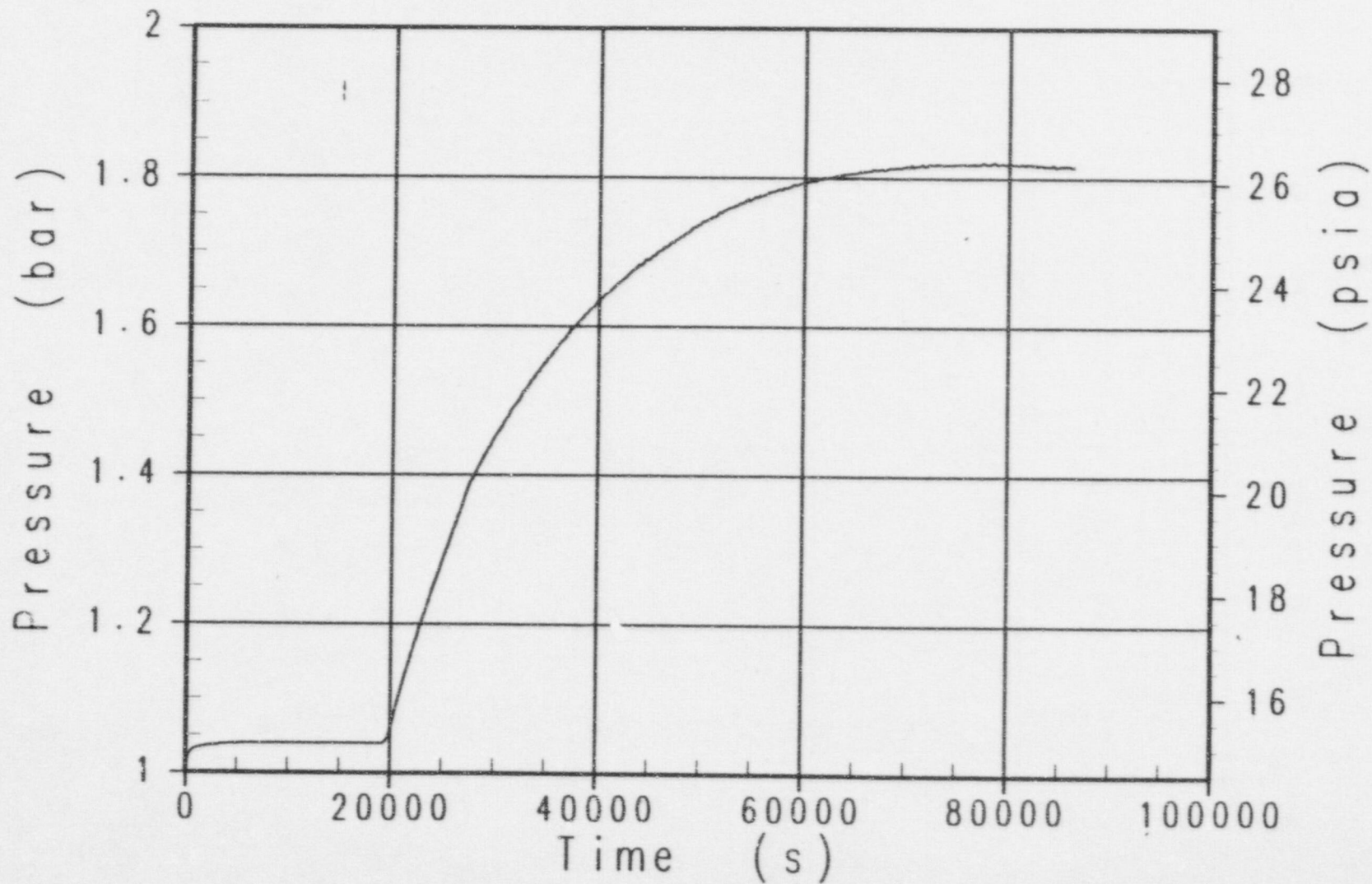

Case t10 AP600 Success Criteria MAAP4 Analysis
Unbroken Loop Steam Generator Pressure

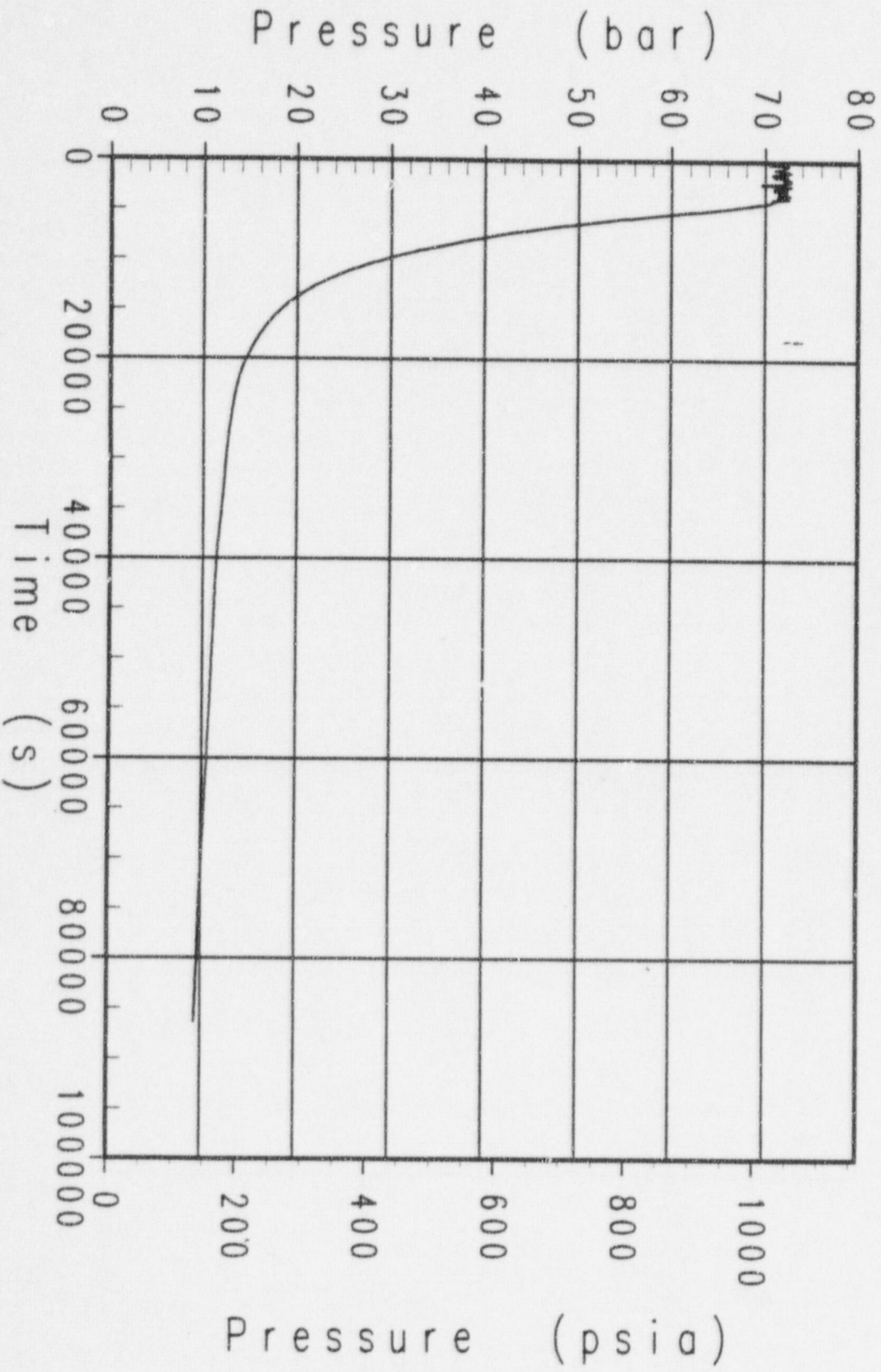

Case t10 AP600 Success Criteria MAAP4 Analysis
Decay Power

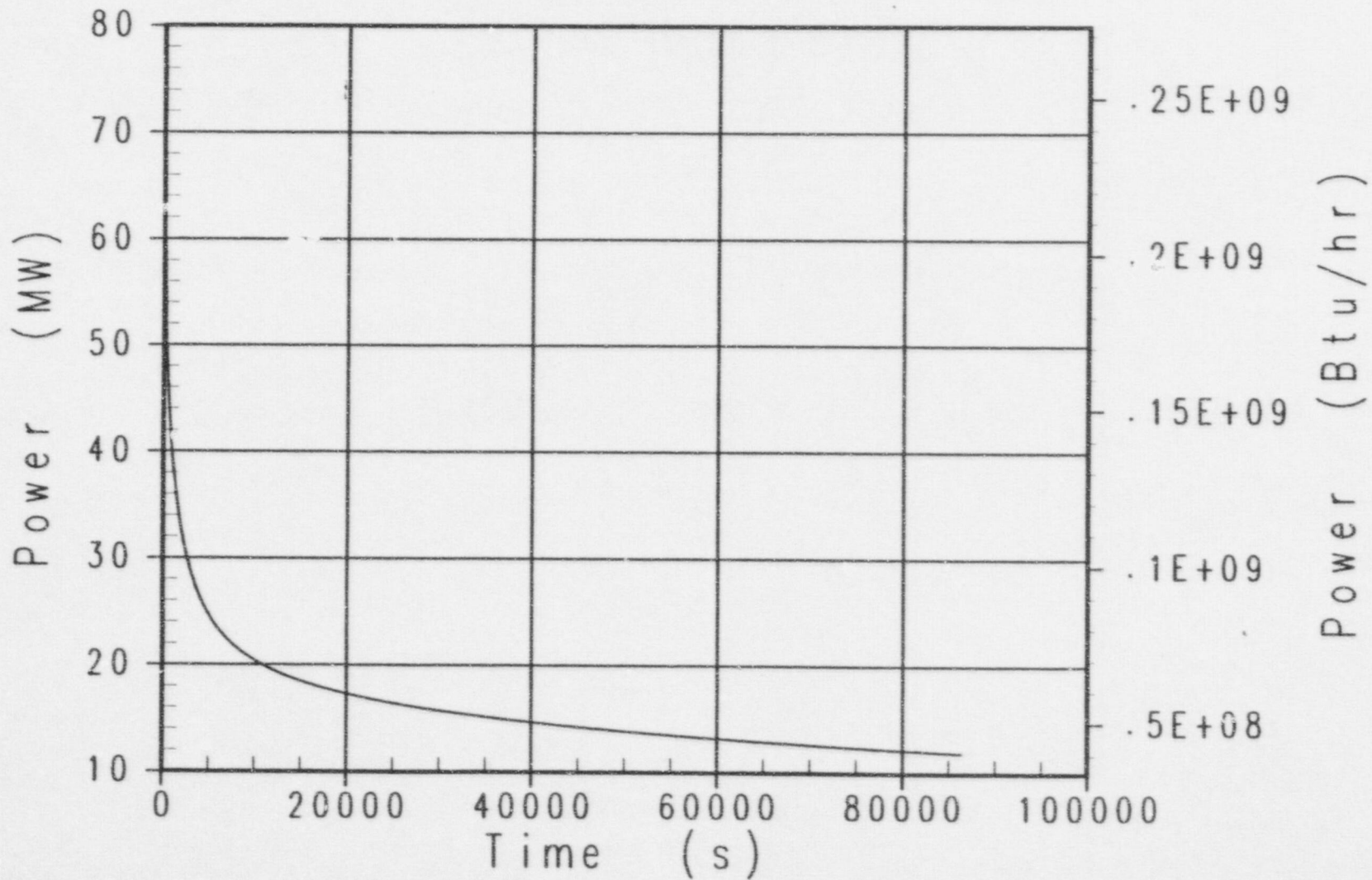

Case t10 AP600 Success Criteria MAAP4 Analysis
PRHR Heat Removal Rate

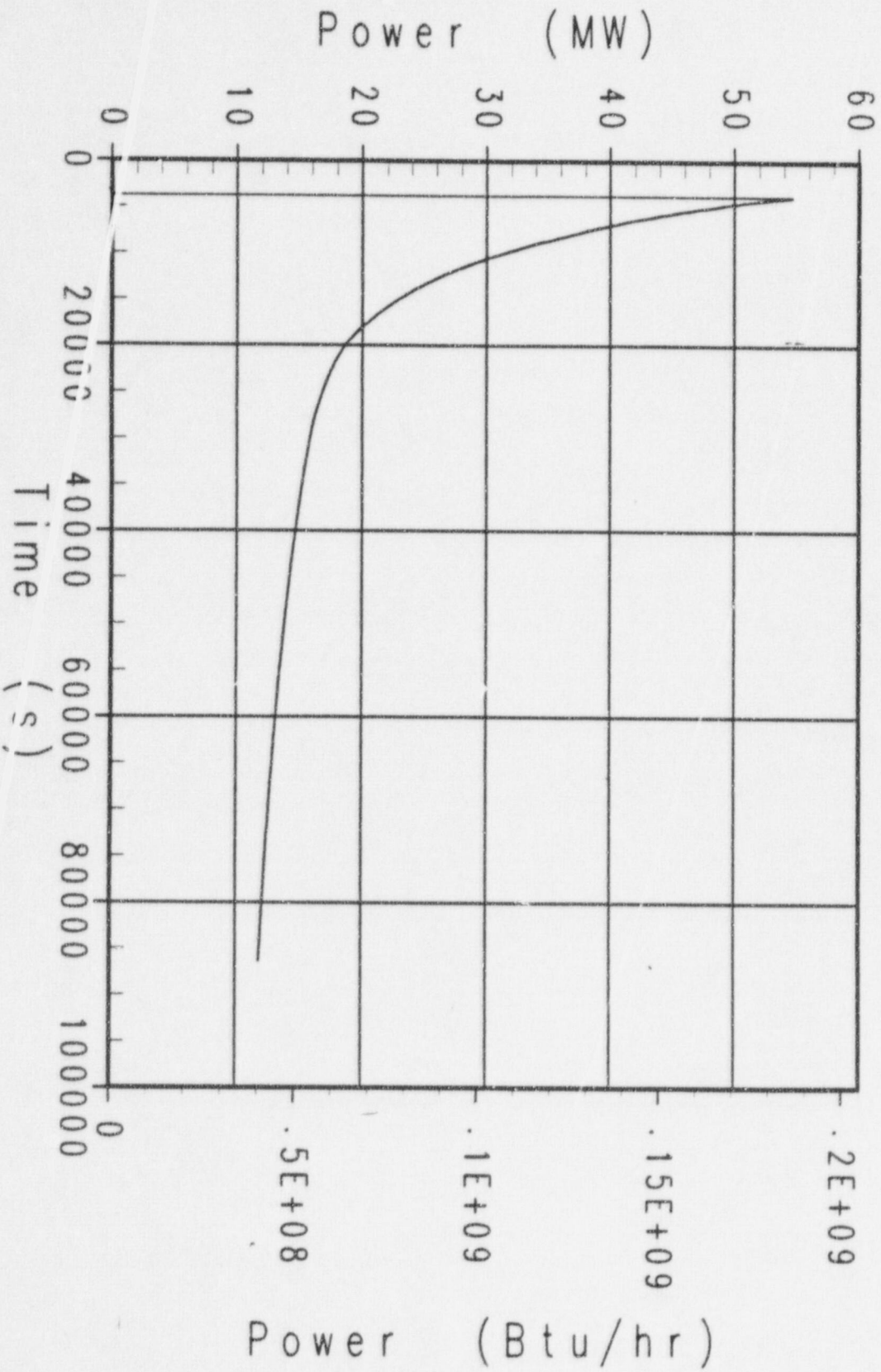

Case t10 AP600 Success Criteria MAAP4 Analysis
Peak Temperature in the Core

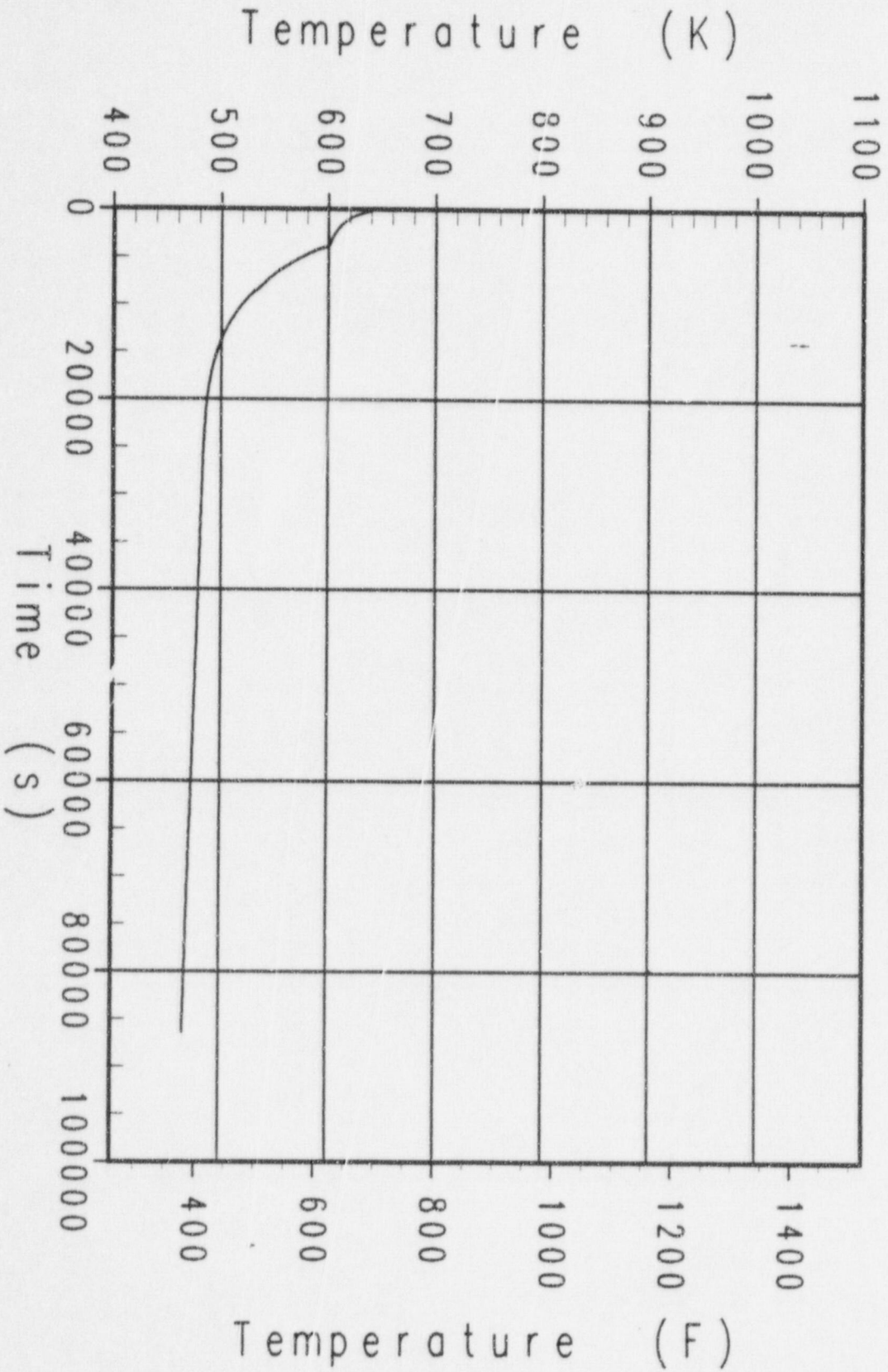

Case t10 AP600 Success Criteria MAAP4 Analysis
Cold Leg Water Temperature

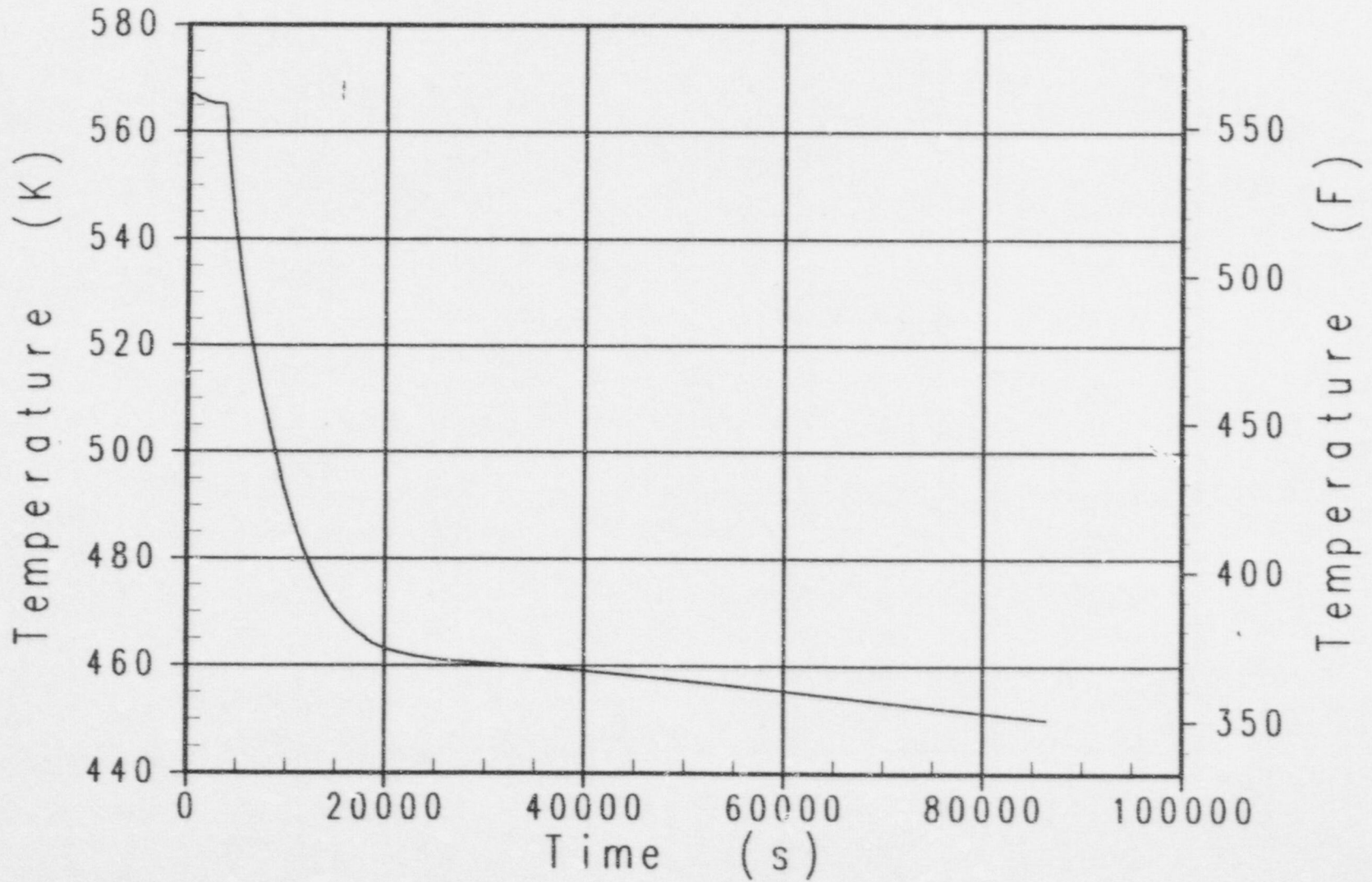

Case 110 AP600 Success Criteria MAAP4 Analysis
Core Water Temperature

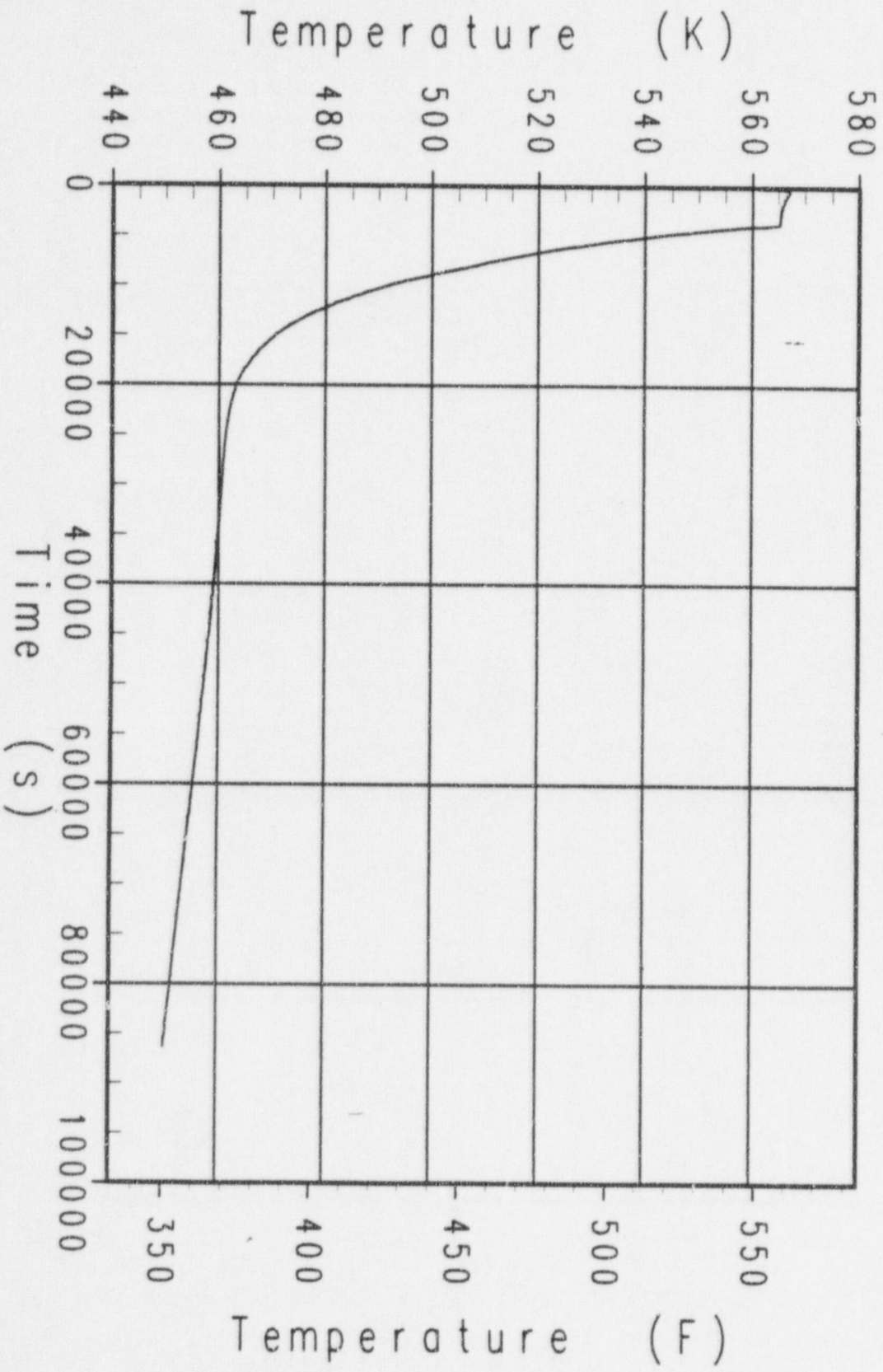

Case t10 AP600 Success Criteria MAAP4 Analysis
RPV Downcomer Water Temperature

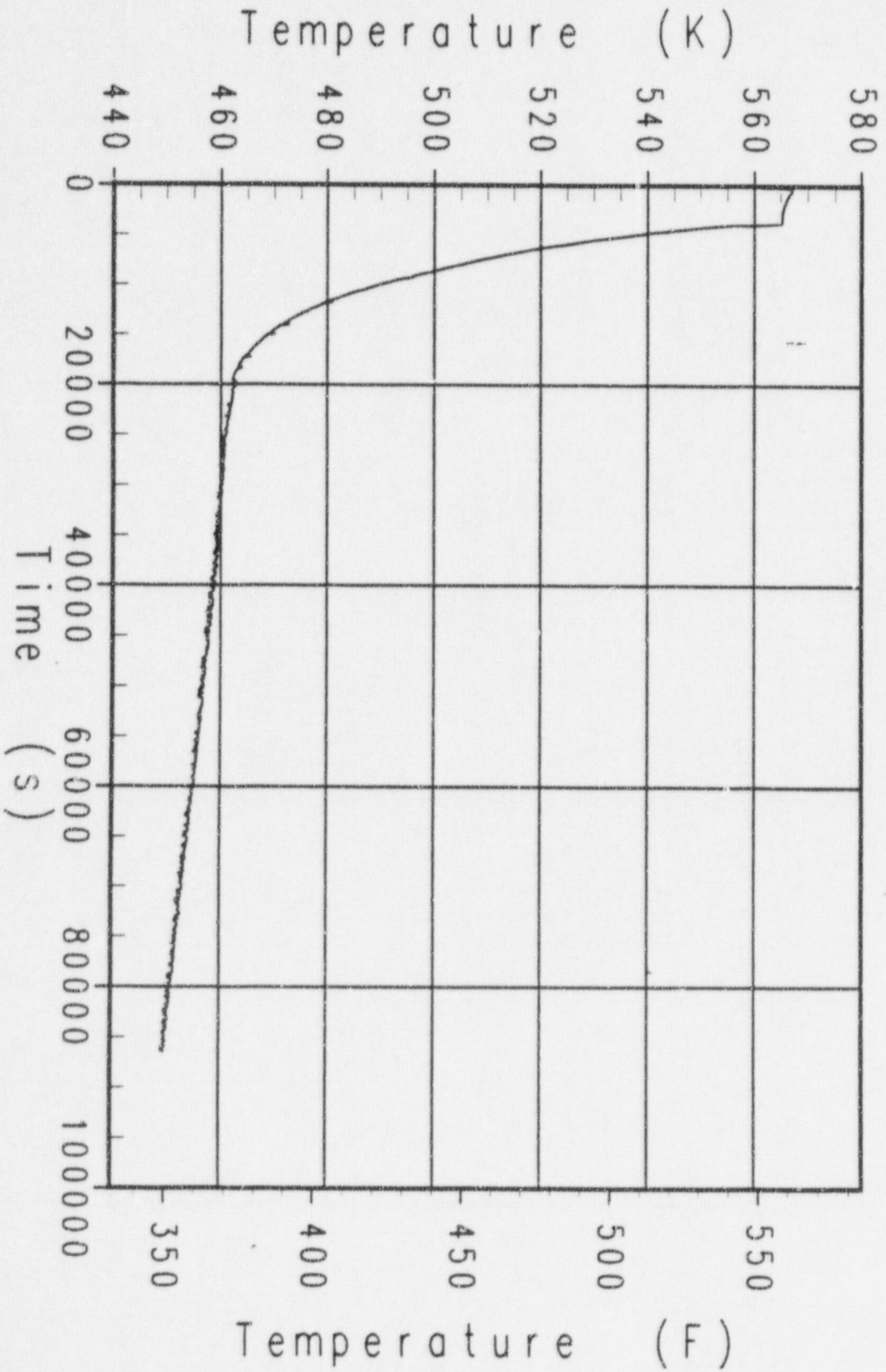

Case t10 AP600 Success Criteria MAAP4 Analysis
IRWST Water Temperature

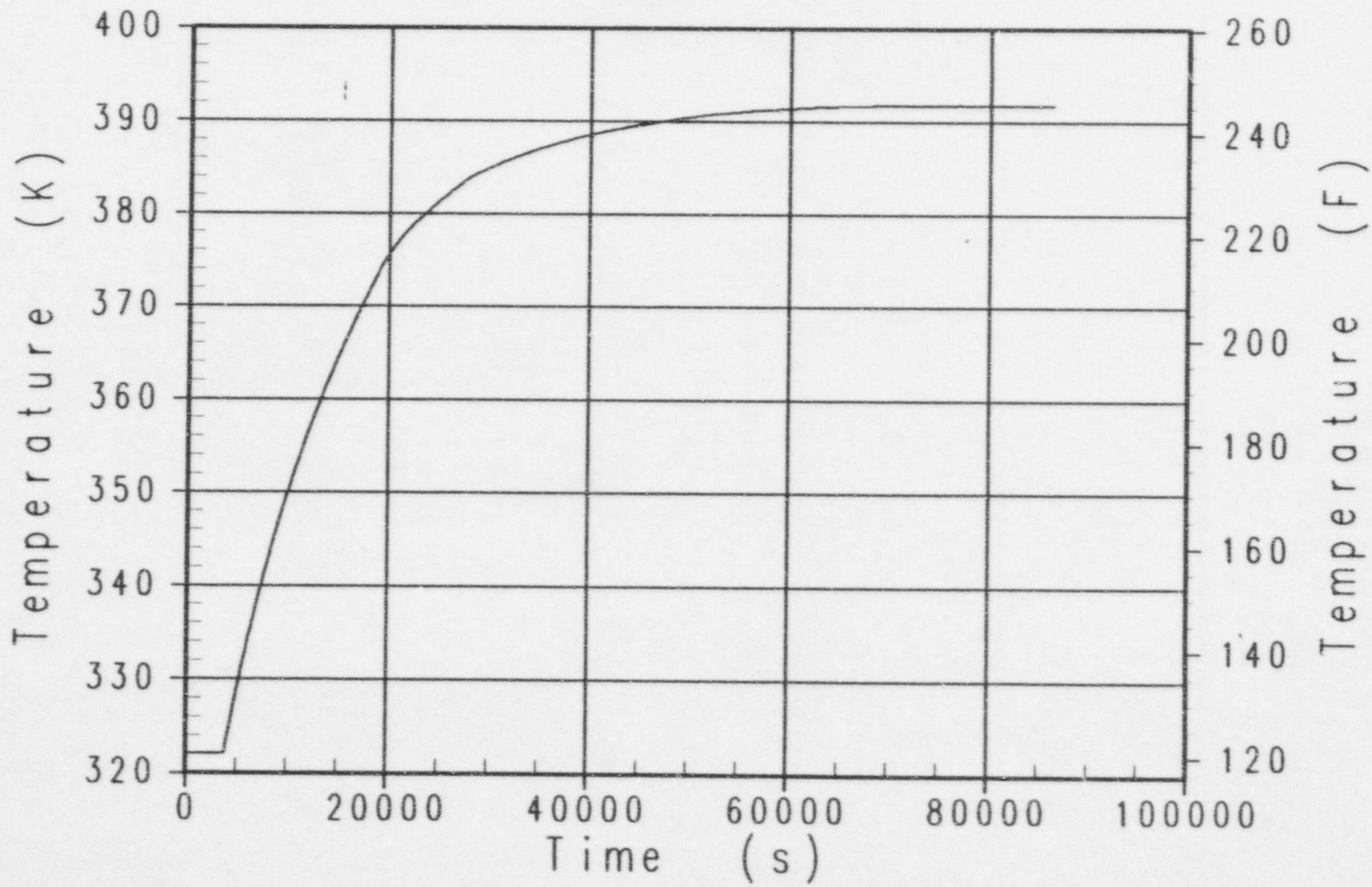

Case t10 AP600 Success Criteria MAAP4 Analysis
Accumulator and N2HR Injection Flowrate

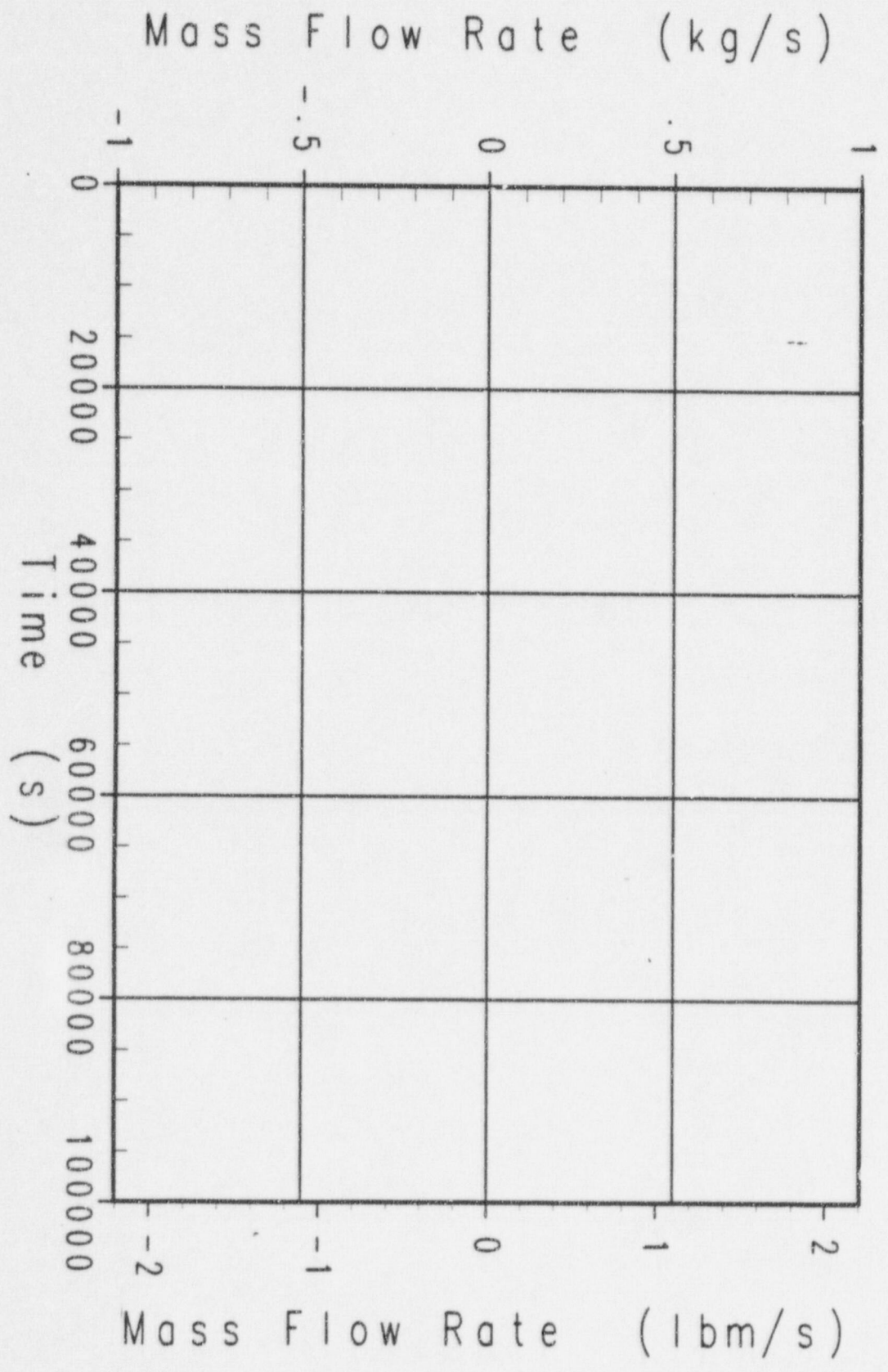

Case t10 AP600 Success Criteria MAAP4 Analysis
RCS Break Gas Flowrate

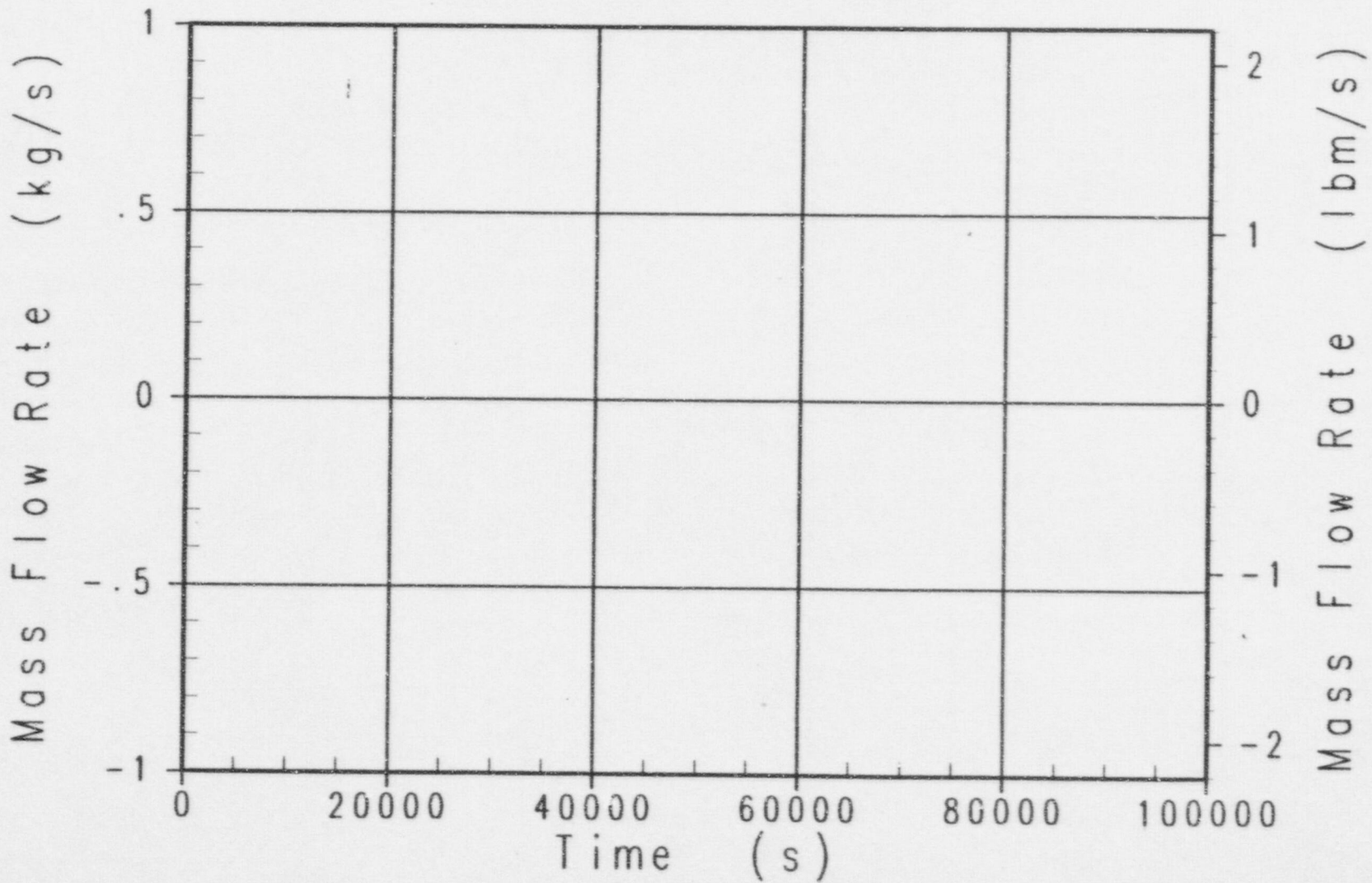

Case t10 AP600 Success Criteria MAPP4 Analysis
ADS Stage 4 Gas Flowrate

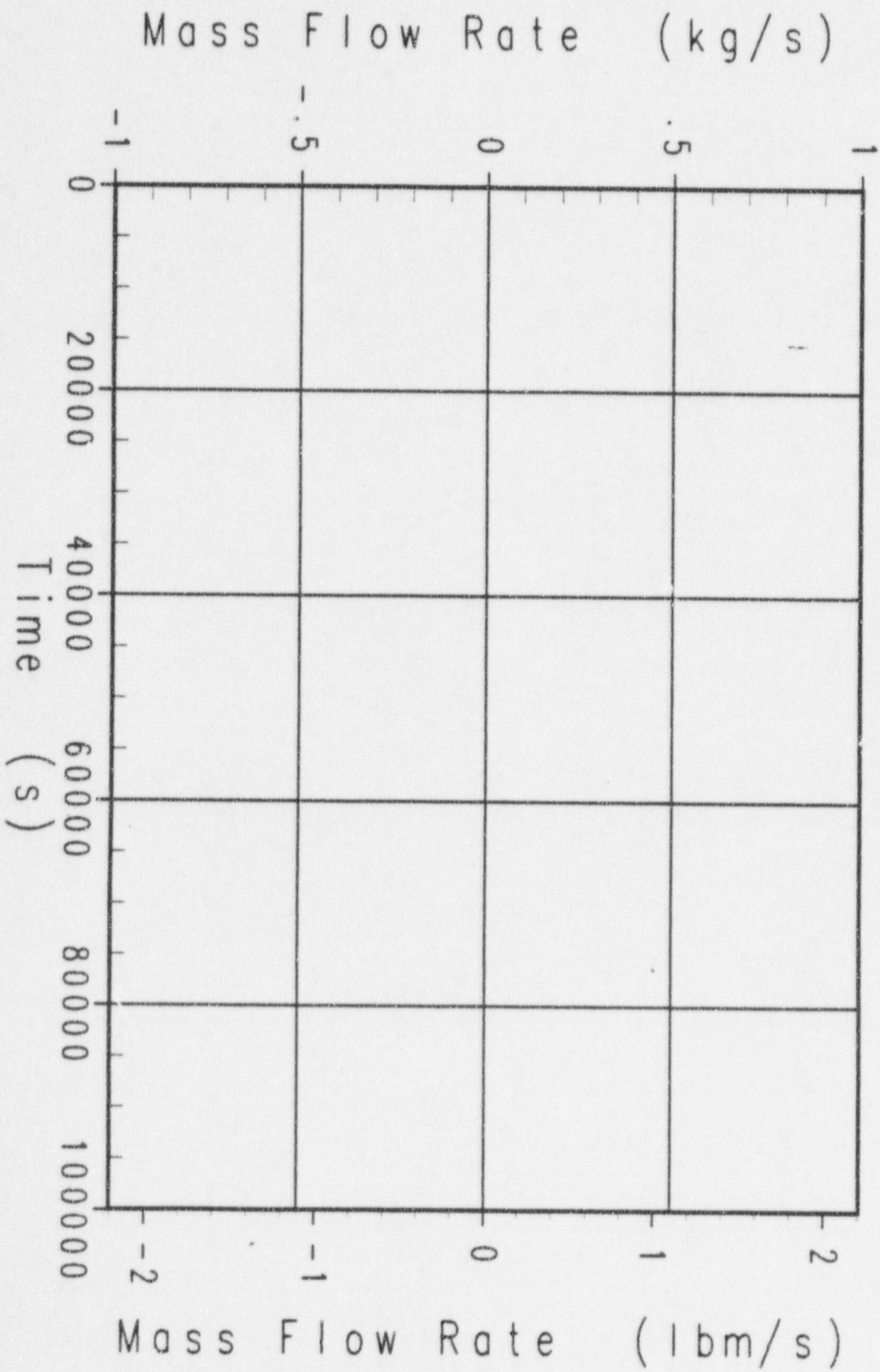

Case 110 AP600 Success Criteria MAMP4 Analysis
Safety Valve and ADS Stages 1-3 Gas Flowrate

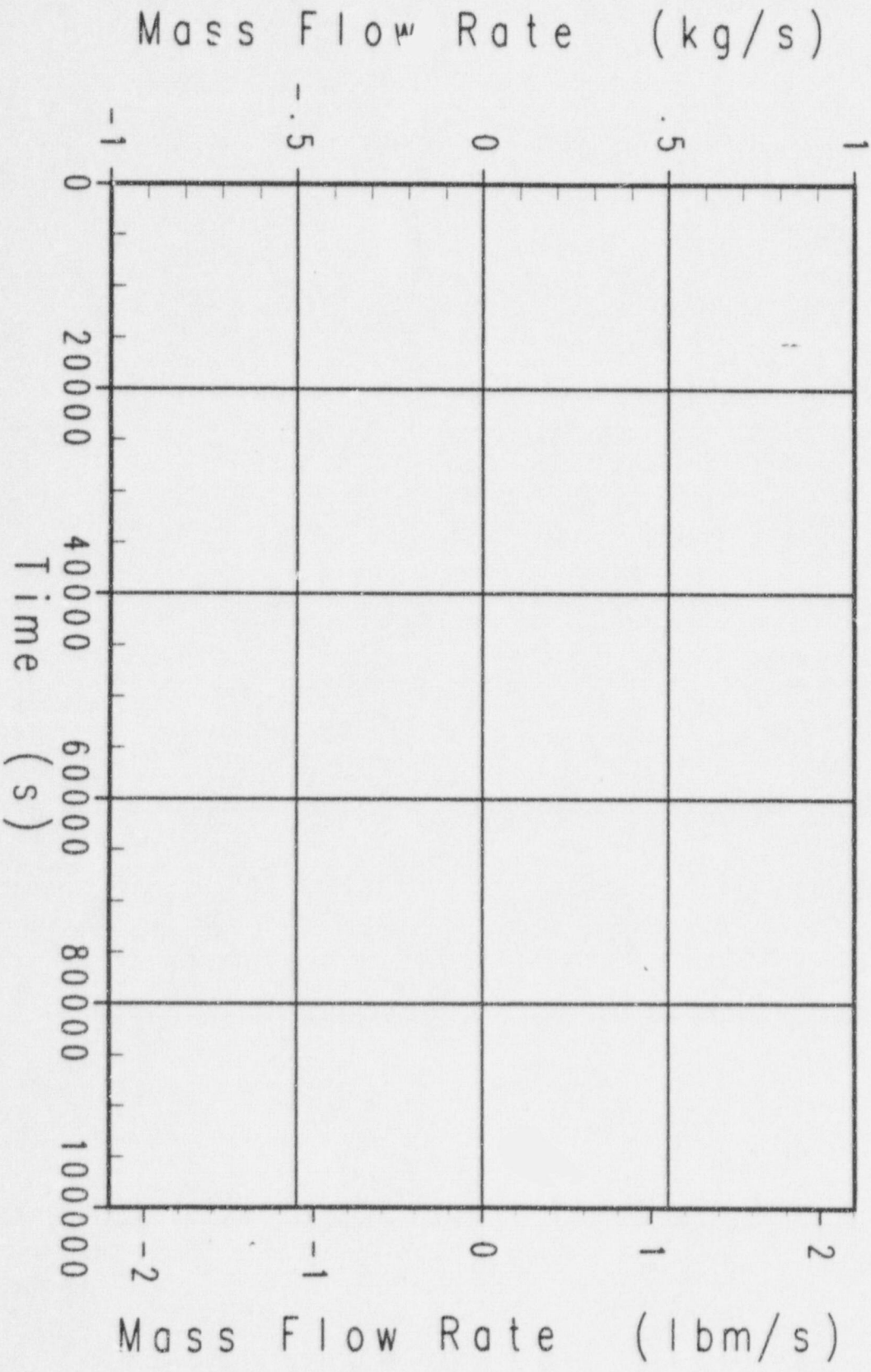

Case t10 AP600 Success Criteria MAAP4 Analysis
RCS Break Liquid Flowrate

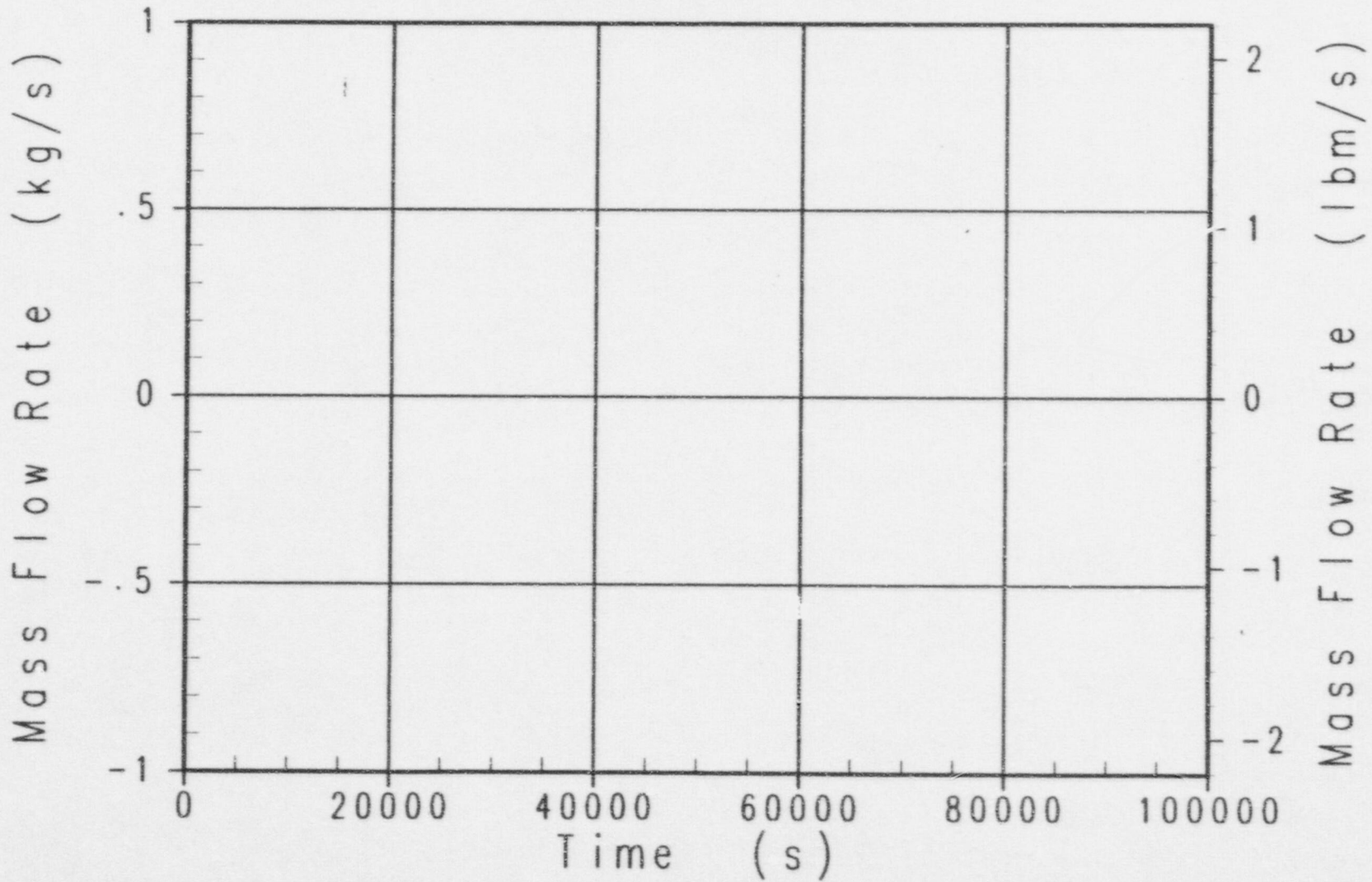

Case t10 AP600 Success Criteria MAA4 Analysis
ADS Stage 4 Liquid Flowrate

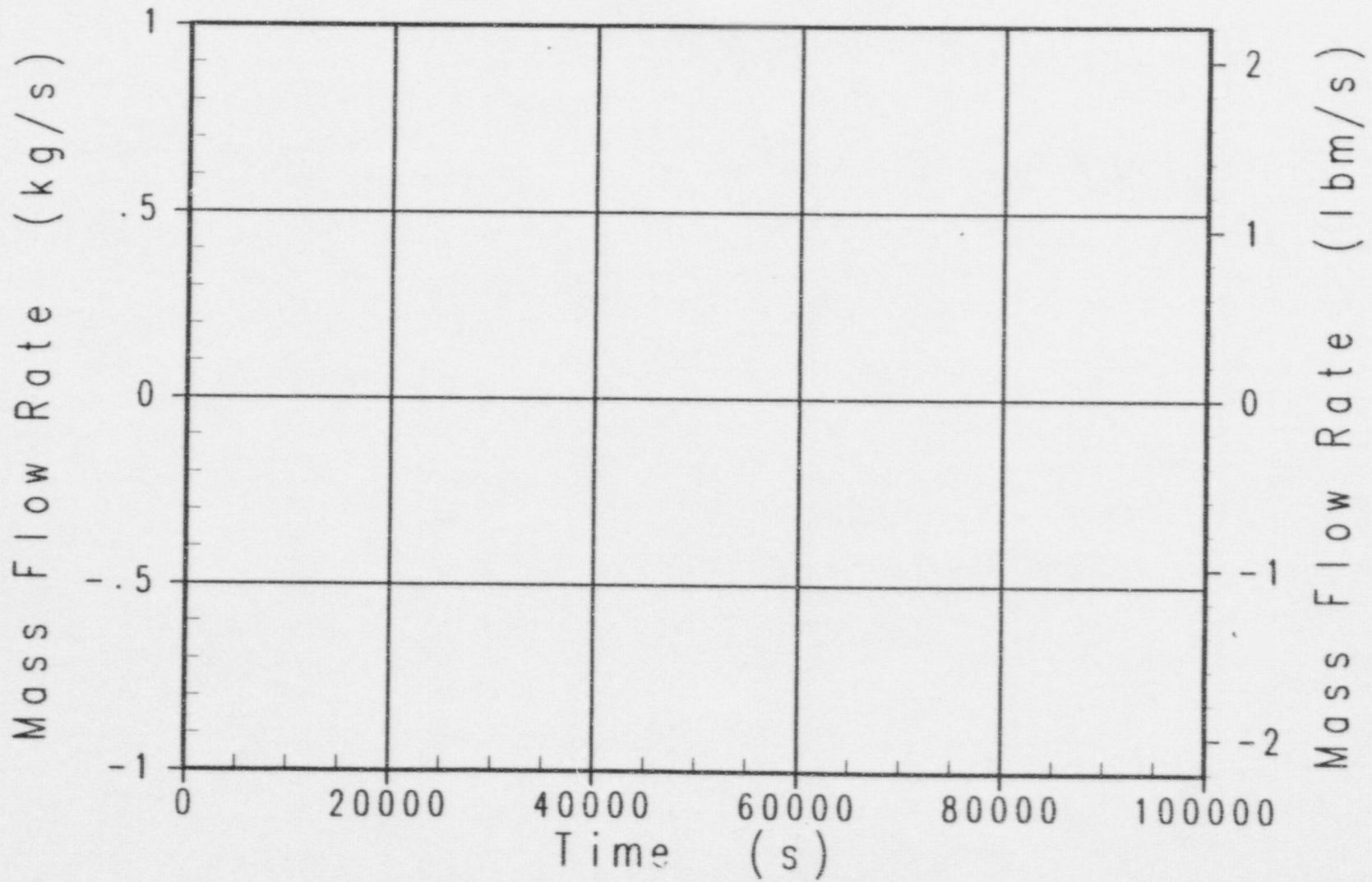

Case t10 AP600 Success Criteria MAAP4 Analysis
IRWST Injection Flowrate (neg. means into RCS)

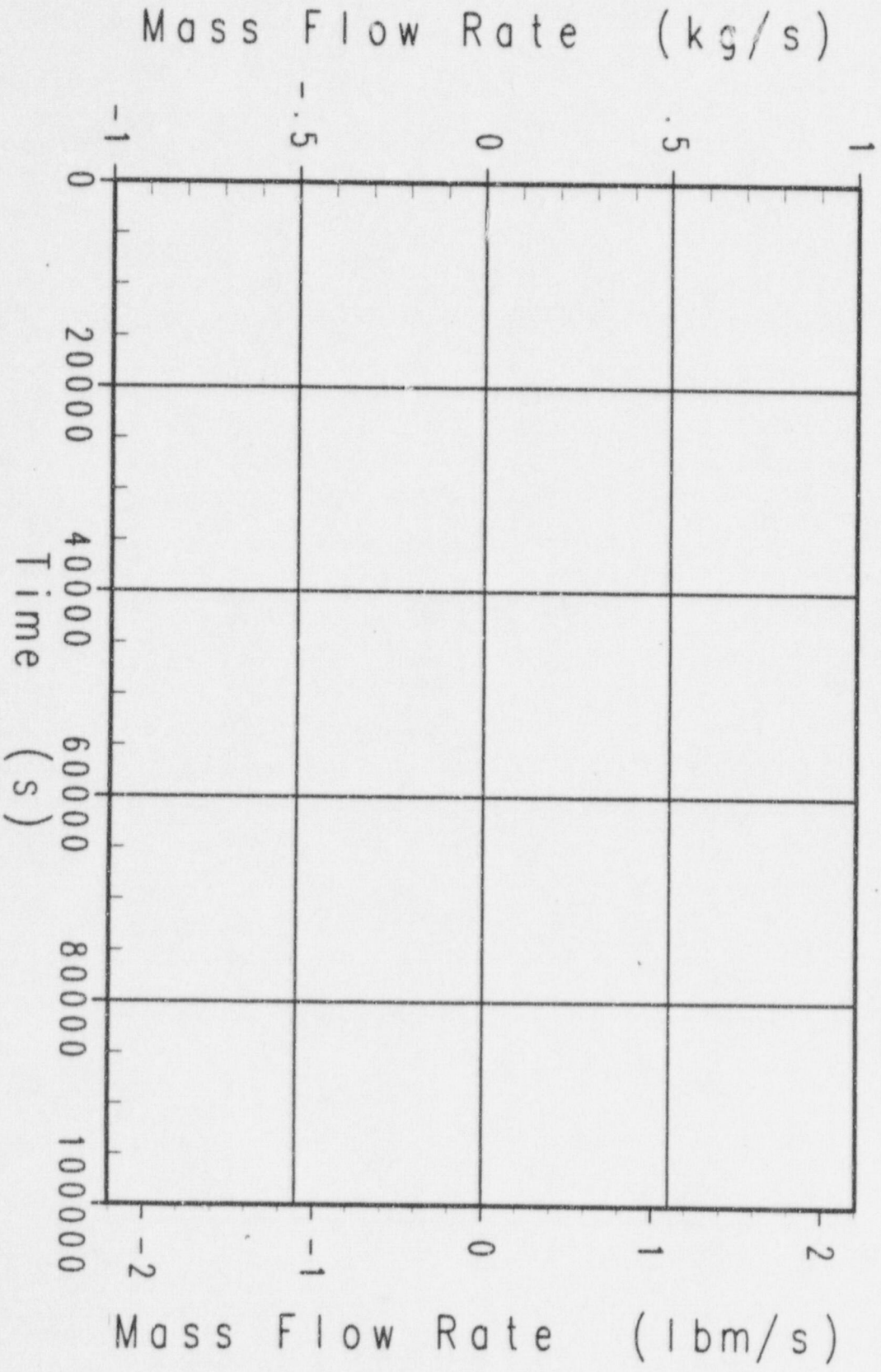

Case t10 AP600 Success Criteria MAAP4 Analysis
CMT-1 Injection Flowrate

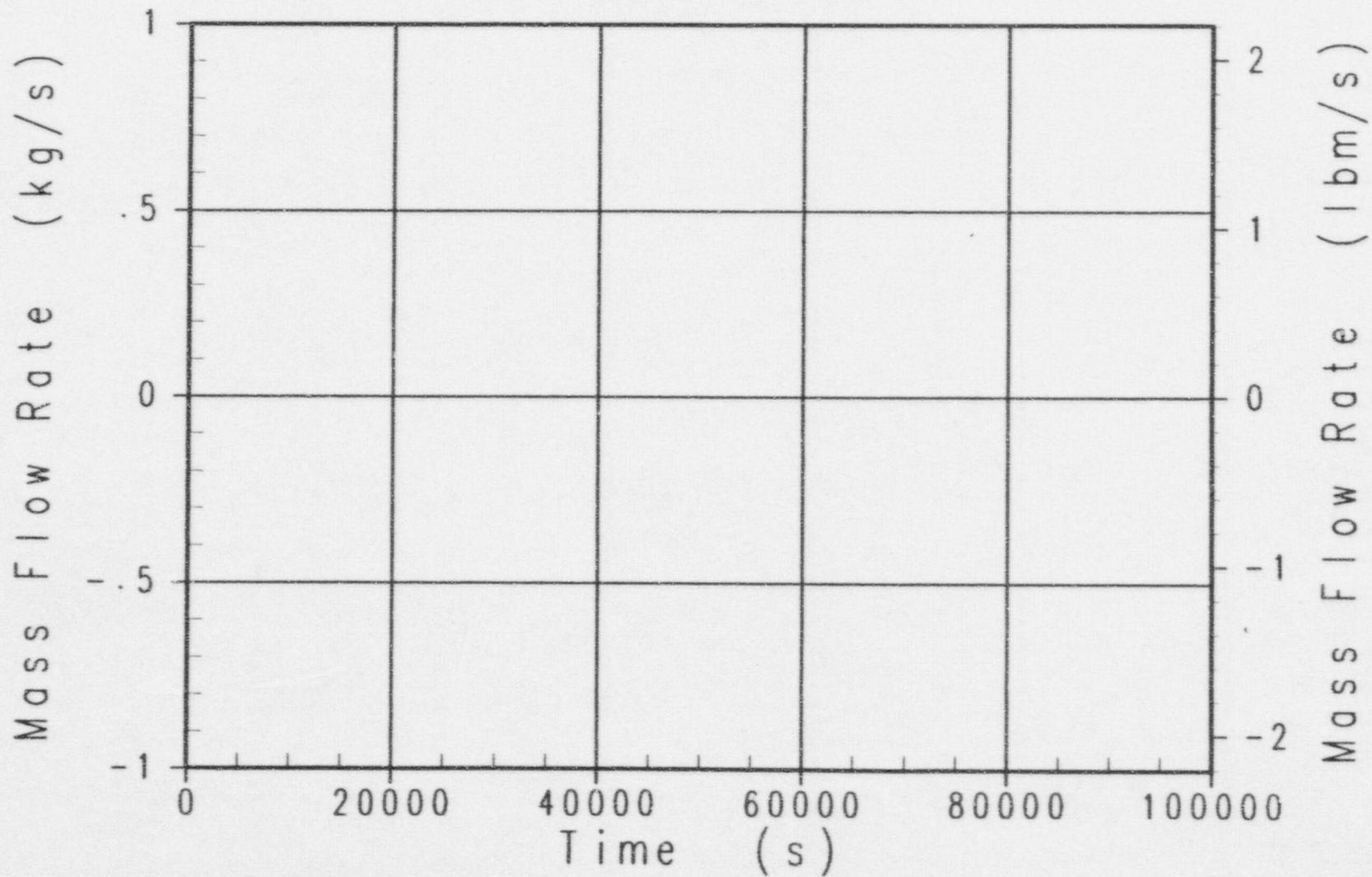

Case t10 AP600 Success Criteria MAAP4 Analysis
Safety Valve and ADS Stages 1-3 Liquid Flowrate

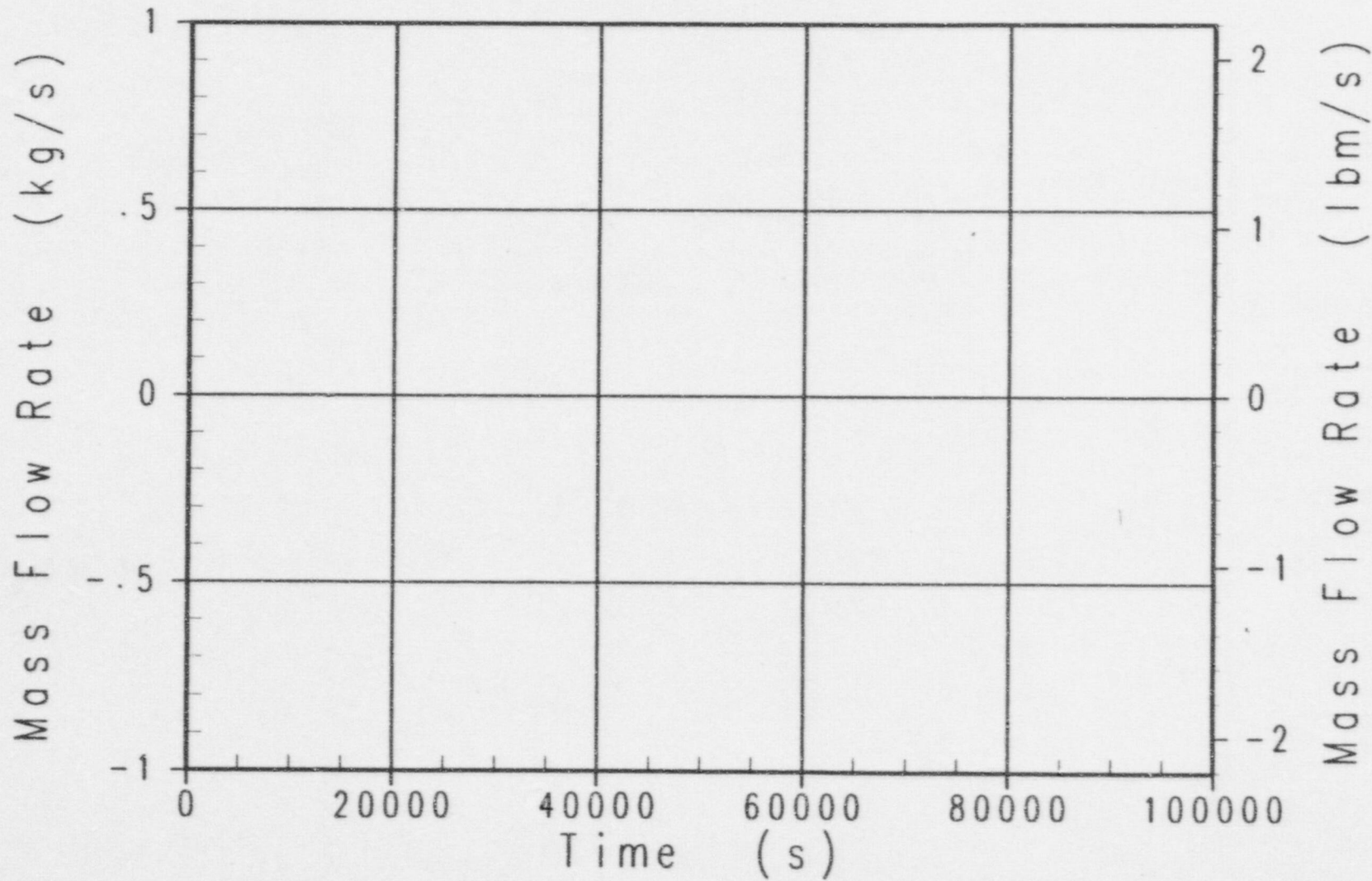

Case t10 AP600 Success Criteria MAAP4 Analysis
CMT-1 Water Level

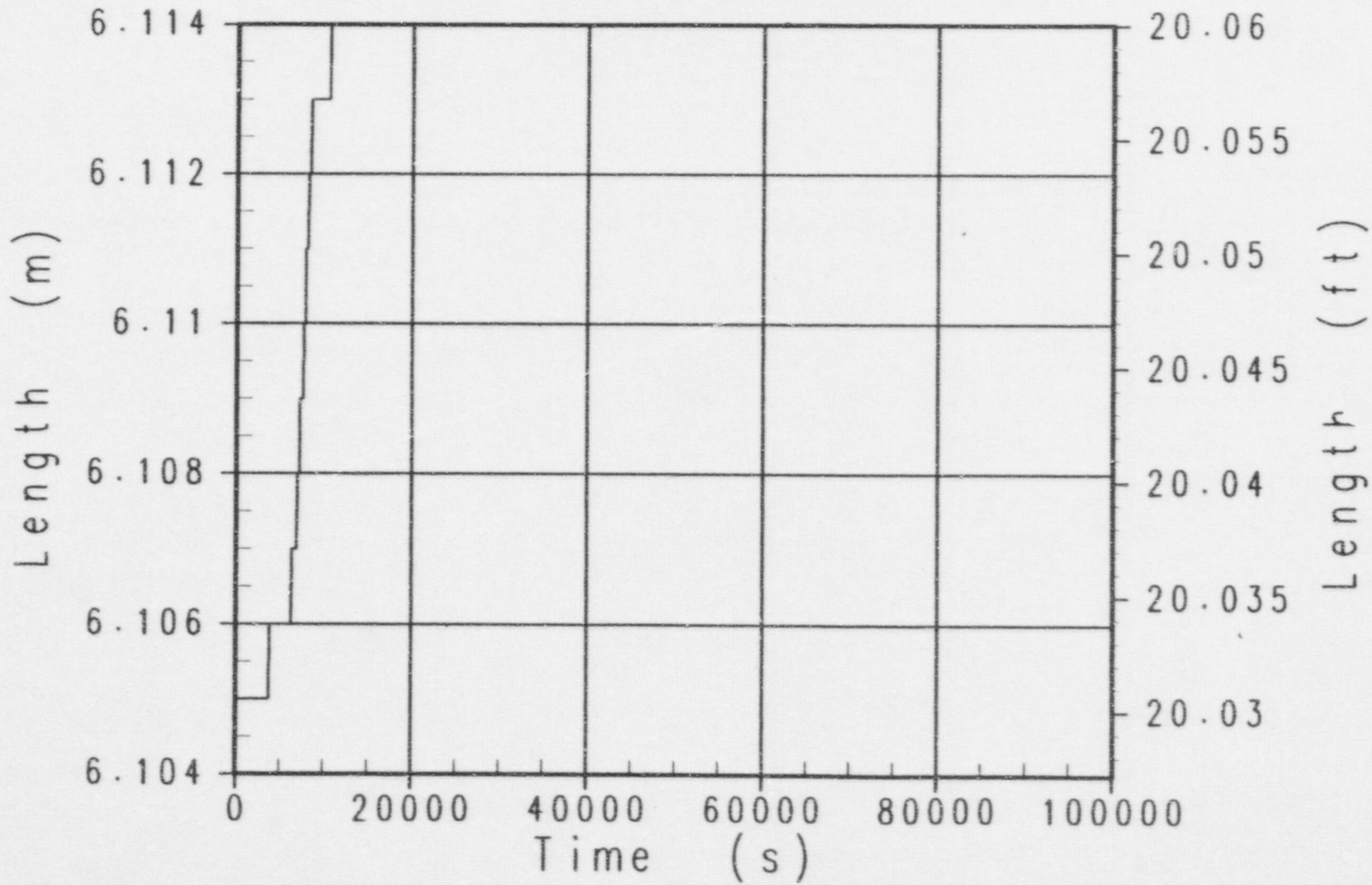

Case t10 AP600 Success Criteria MAAP4 Analysis
Pressurizer Water Level (From Pzr Bottom)

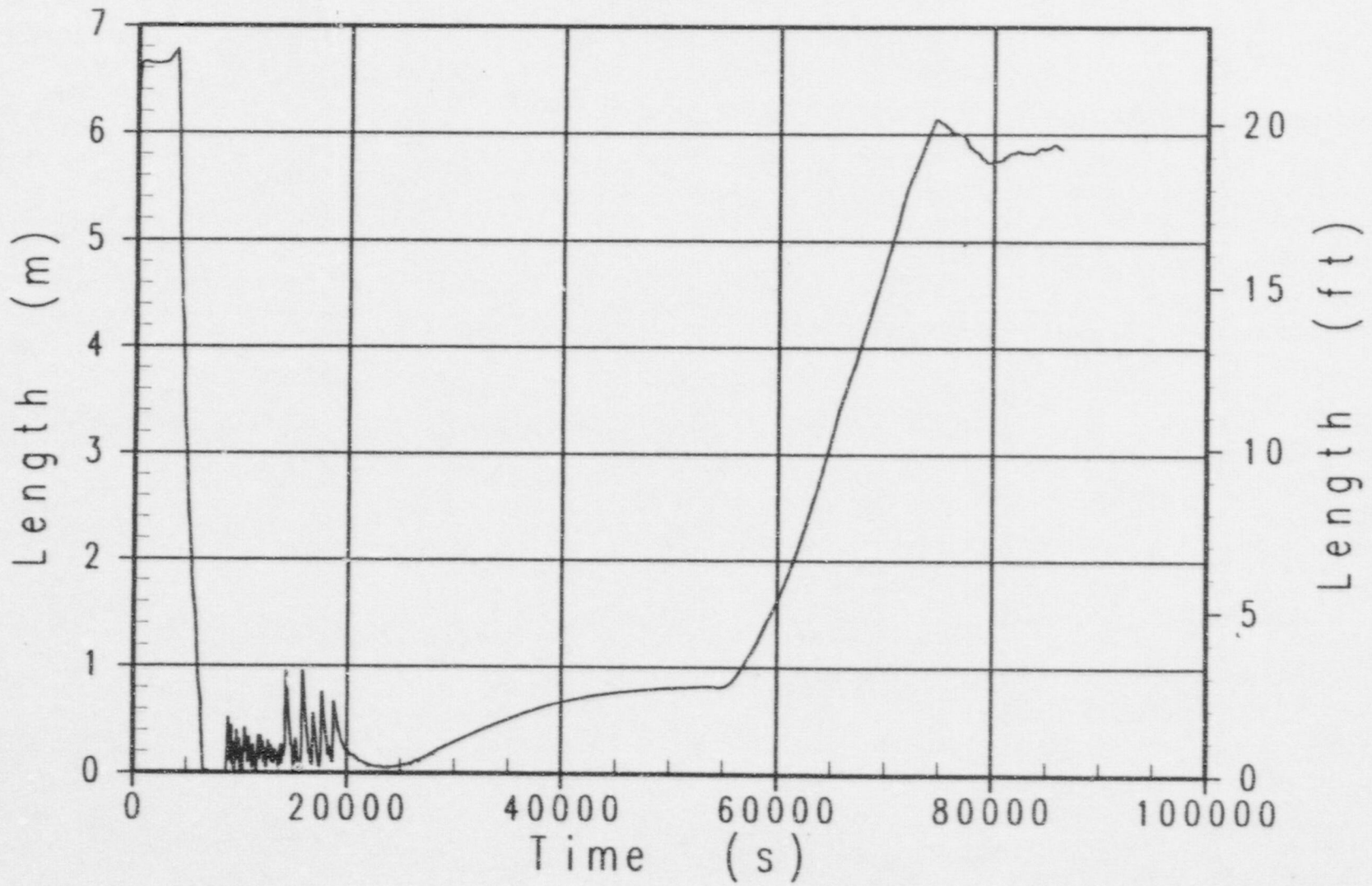

Case m3g AP600 Success Criteria MAAP4 Analysis
Broken Loop Steam Generator Pressure

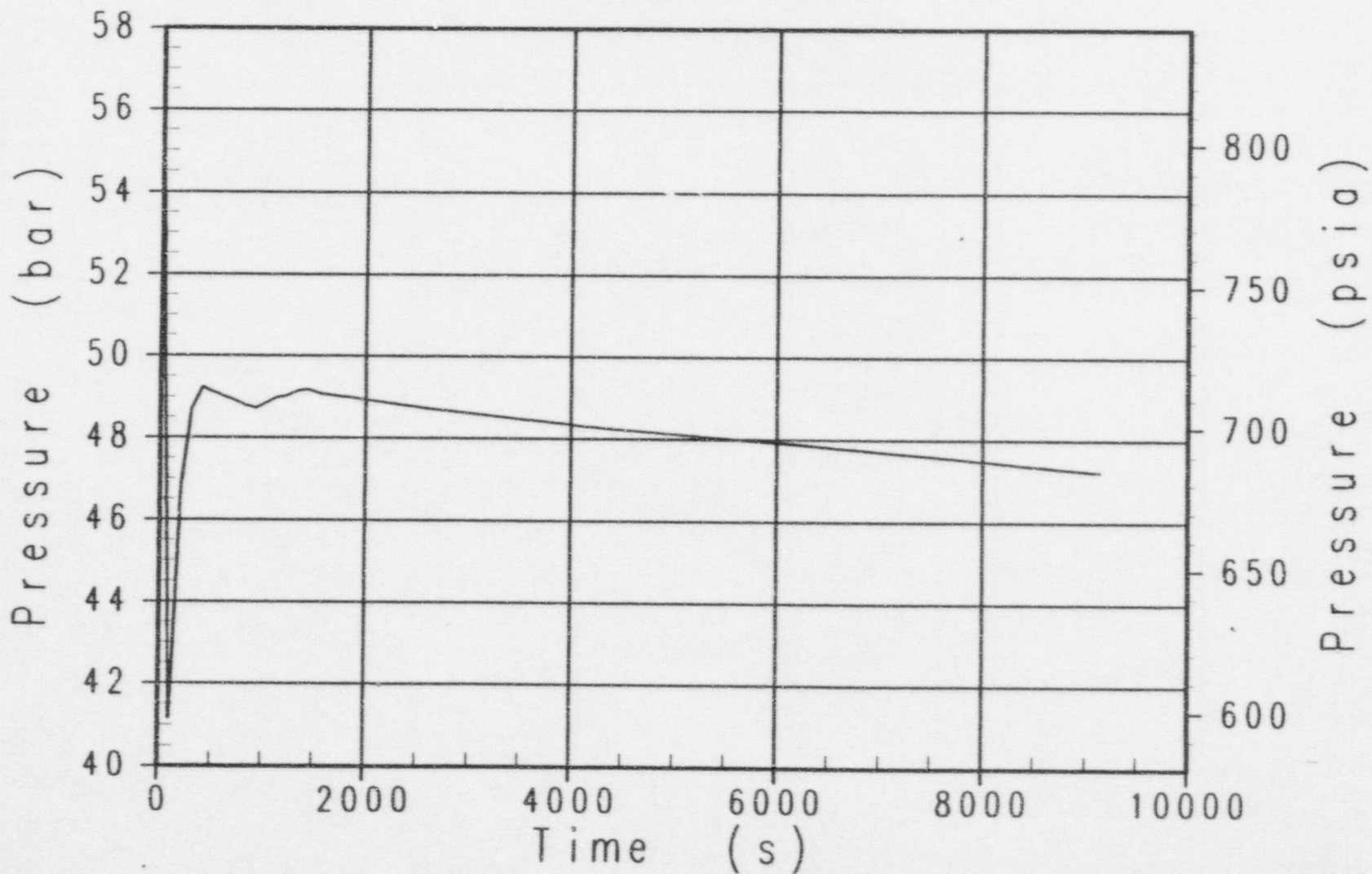

Case m3g AP600 Success Criteria MAAP4 Analysis
Primary System Pressure

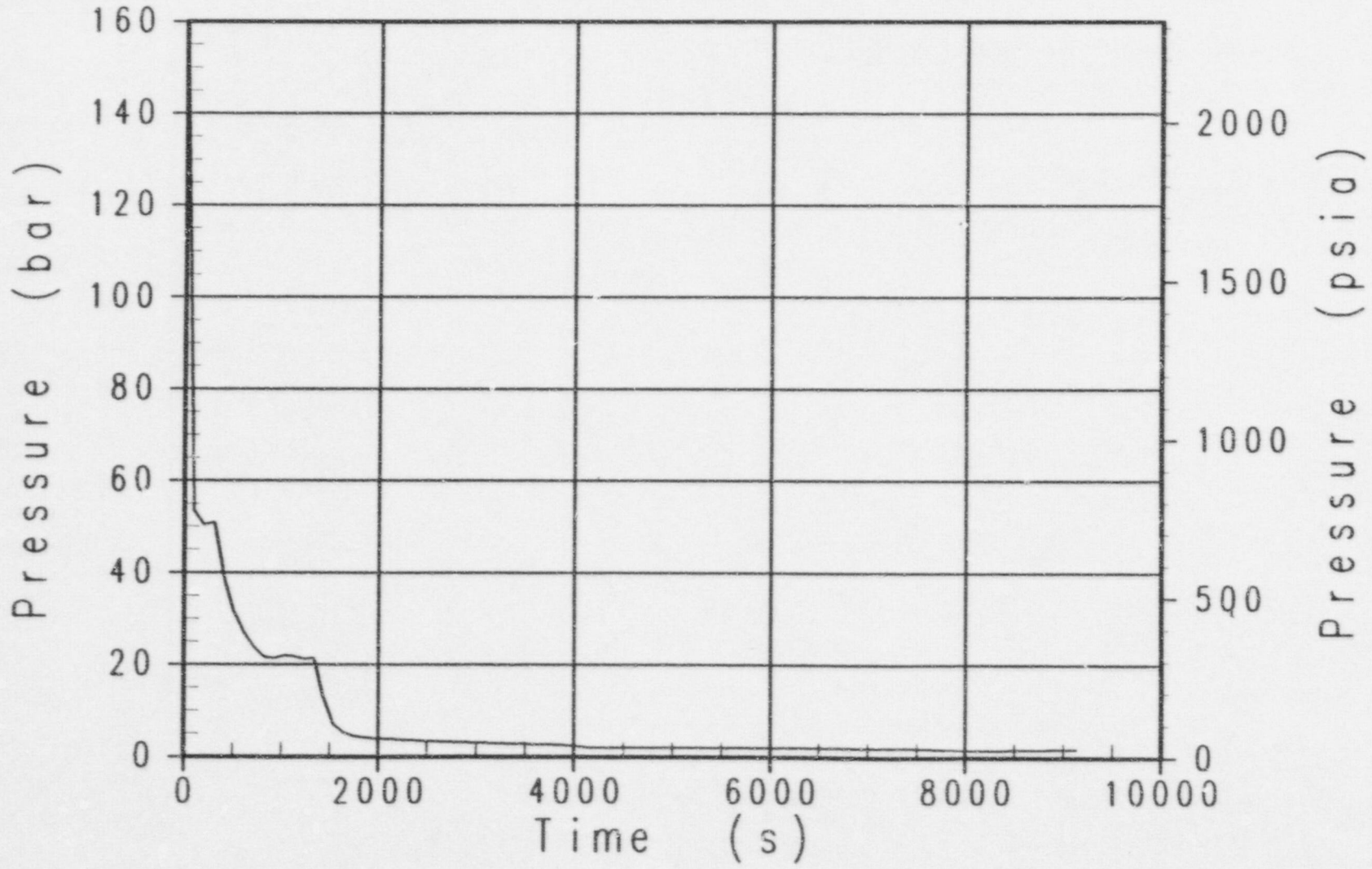

Case m3g AP600 Success Criteria MAAP4 Analysis
Containment Pressure

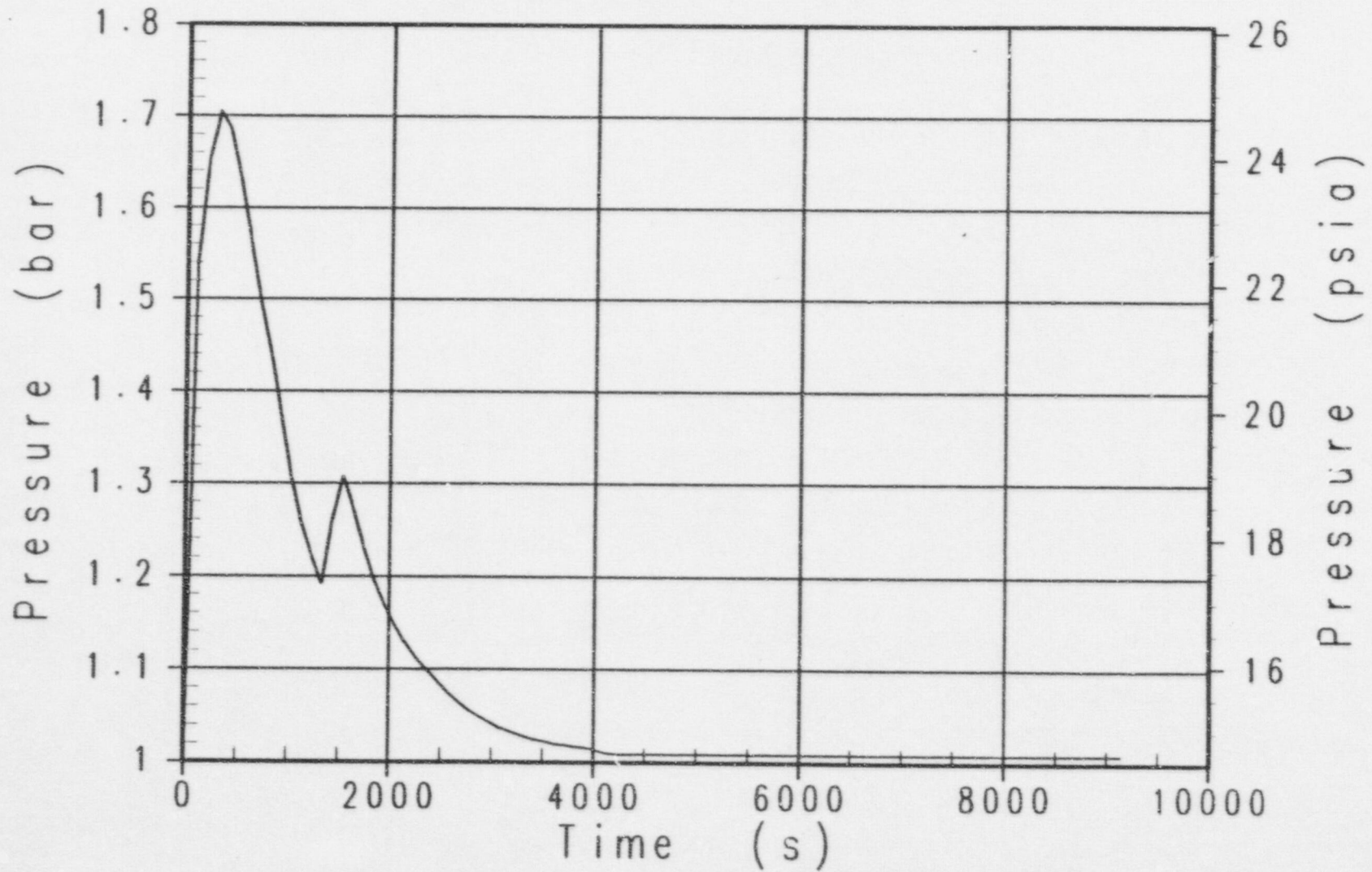

Case m3g AP600 Success Criteria MAAP4 Analysis
Unbroken Loop Steam Generator Pressure

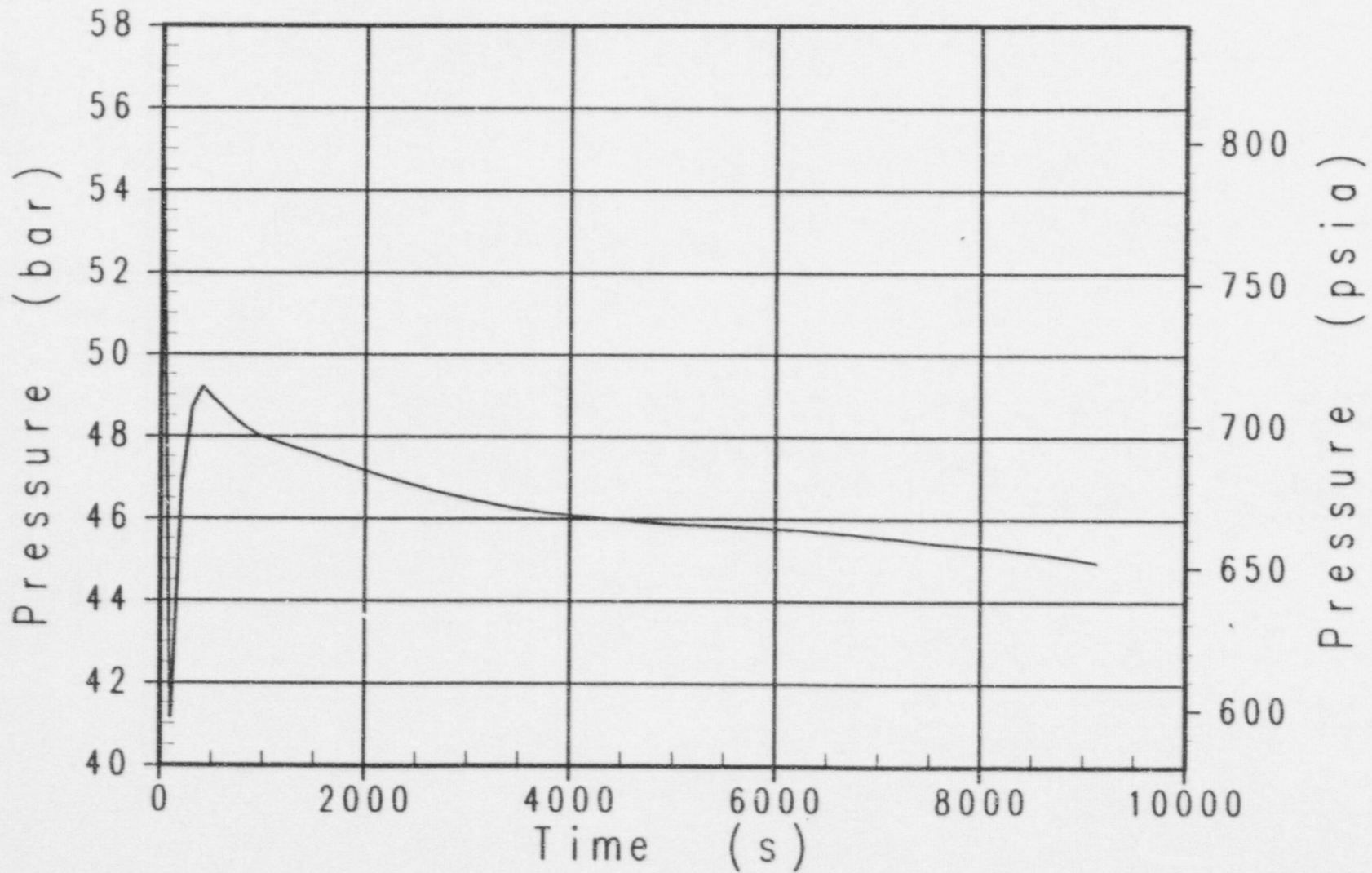

Case m3g AP600 Success Criteria MAAP4 Analysis
Decay Power

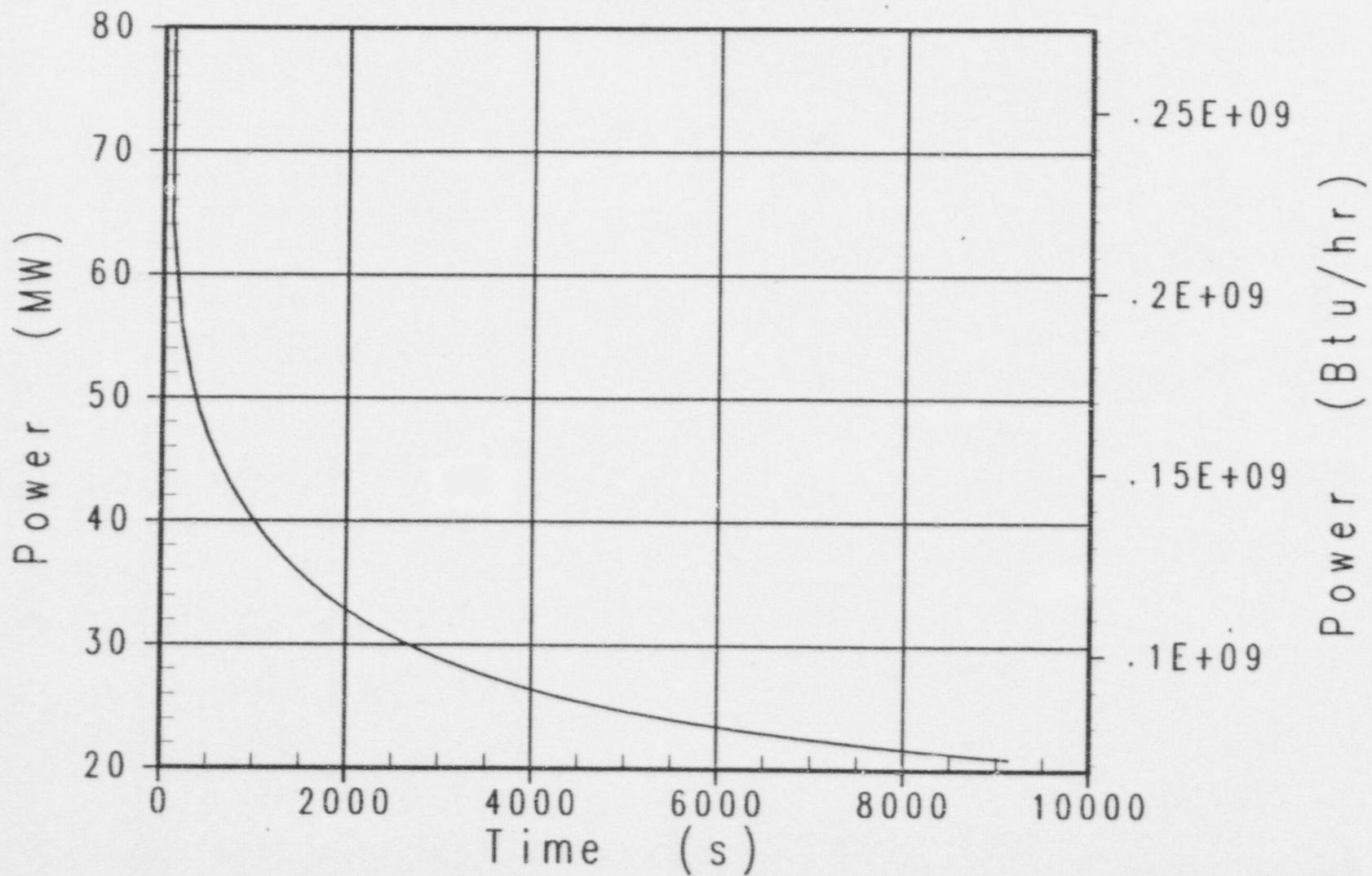

Case m3g AP600 Success Criteria MAAP4 Analysis
PRHR Heat Removal Rate

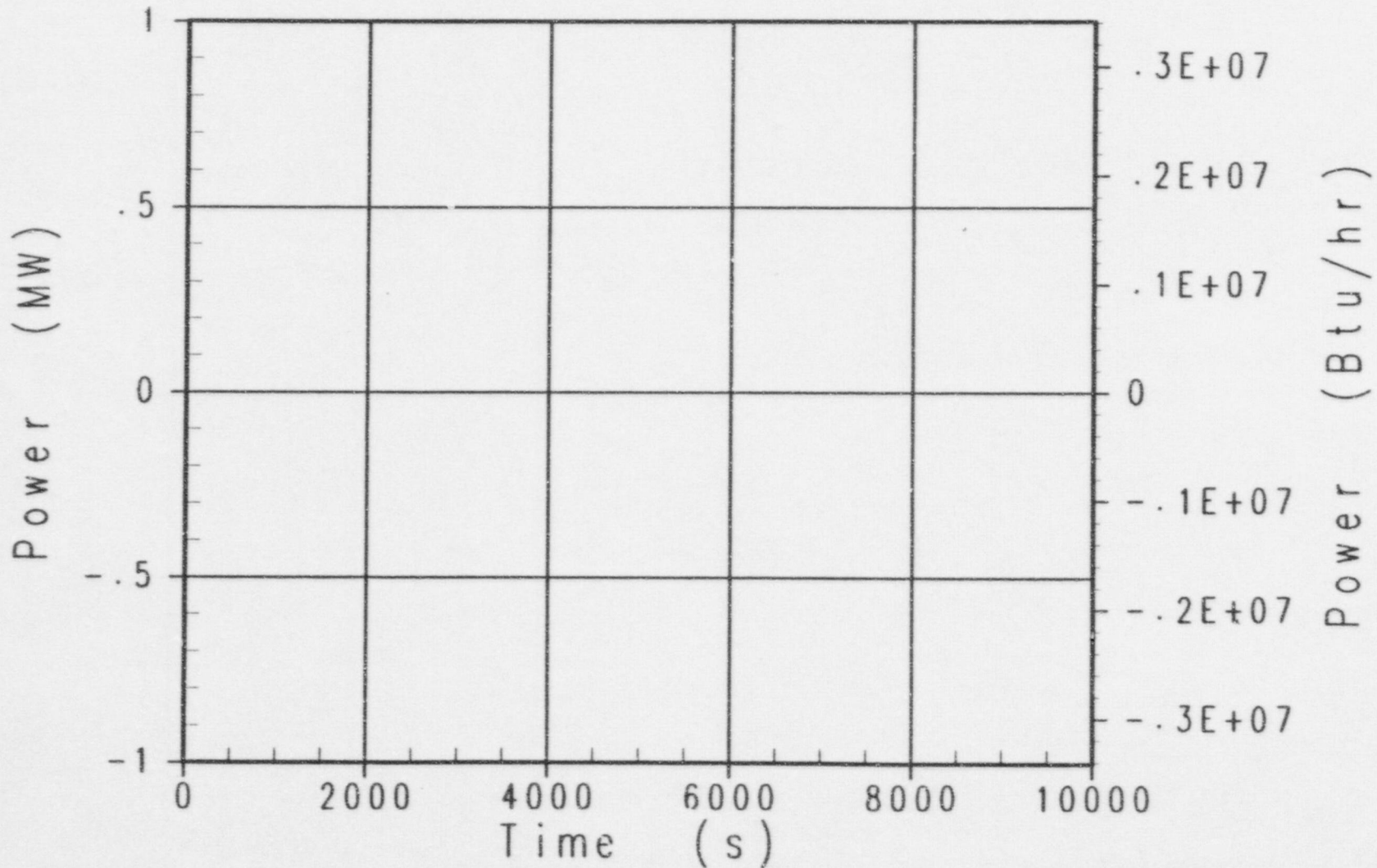

Case m3g AP600 Success Criteria MAAP4 Analysis
Peak Temperature in the Core

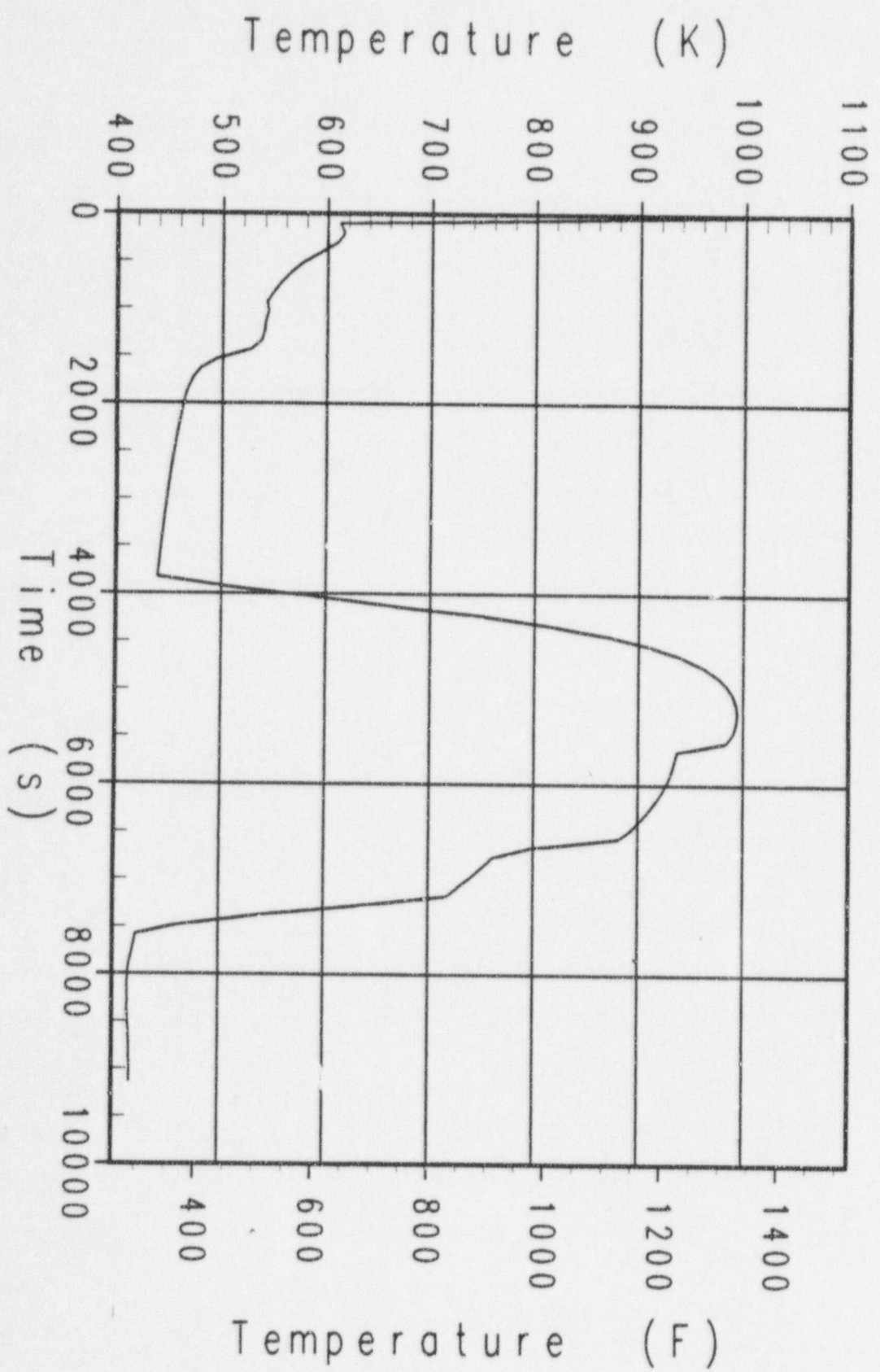

Case m3g AP600 Success Criteria MAAP4 Analysis
Cold Leg Water Temperature

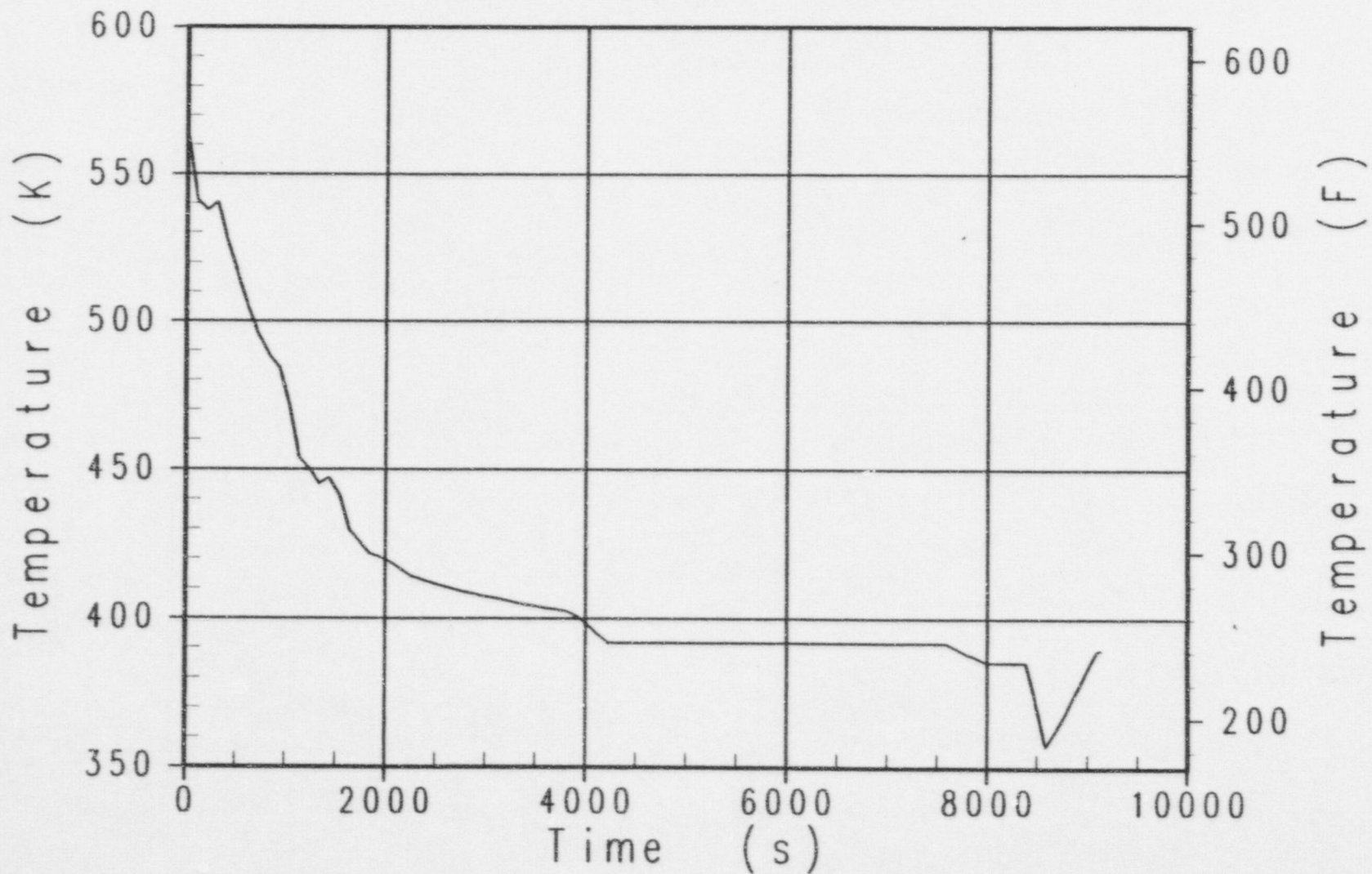

Case m3g AP600 Success Criteria MAAP4 Analysis
RPV Downcomer Water Temperature

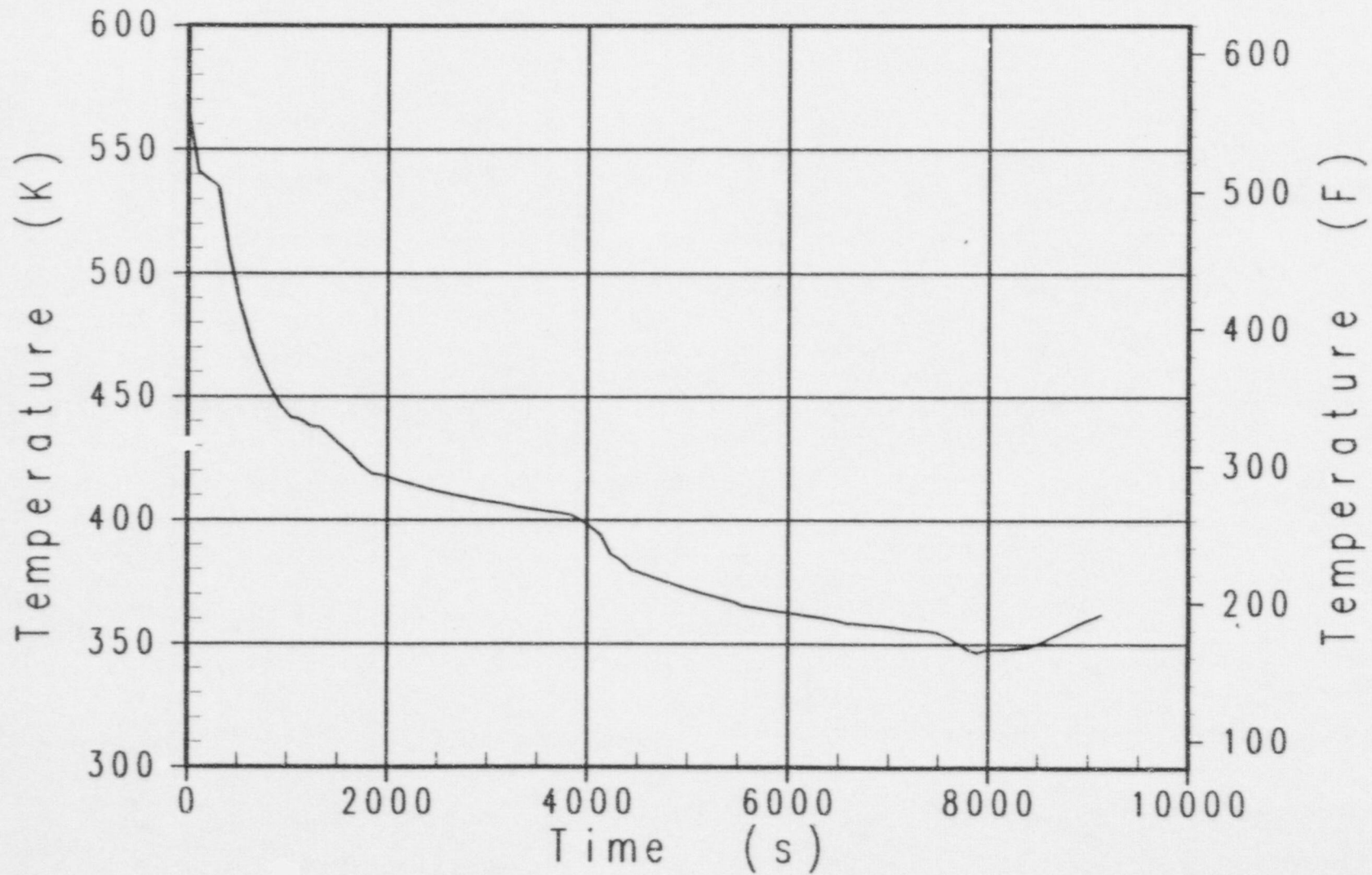

Case m3g AP600 Success Criteria MAAP4 Analysis
Core Water Temperature

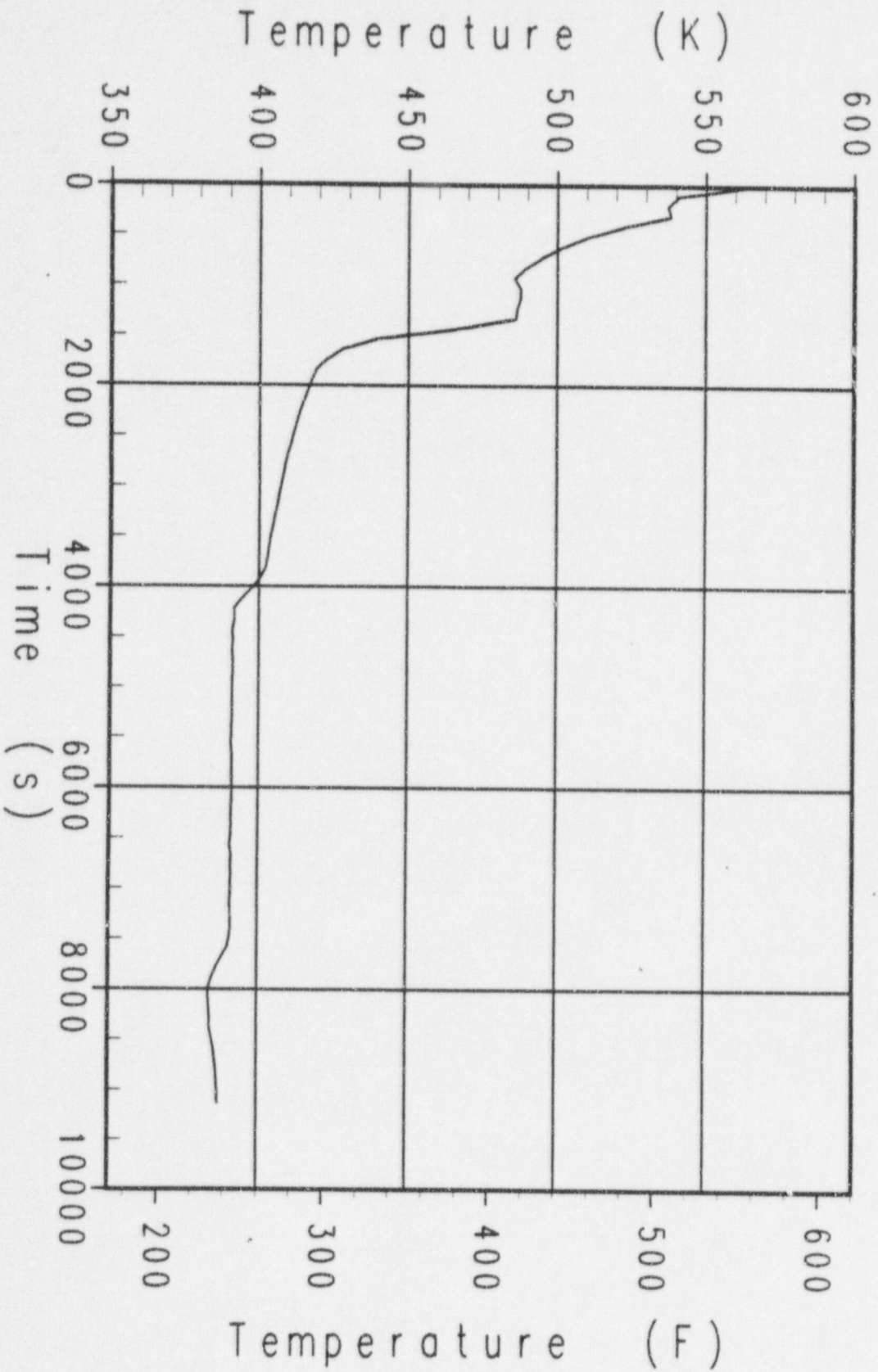

Case m3g AP600 Success Criteria MAAP4 Analysis
IRWST Water Temperature

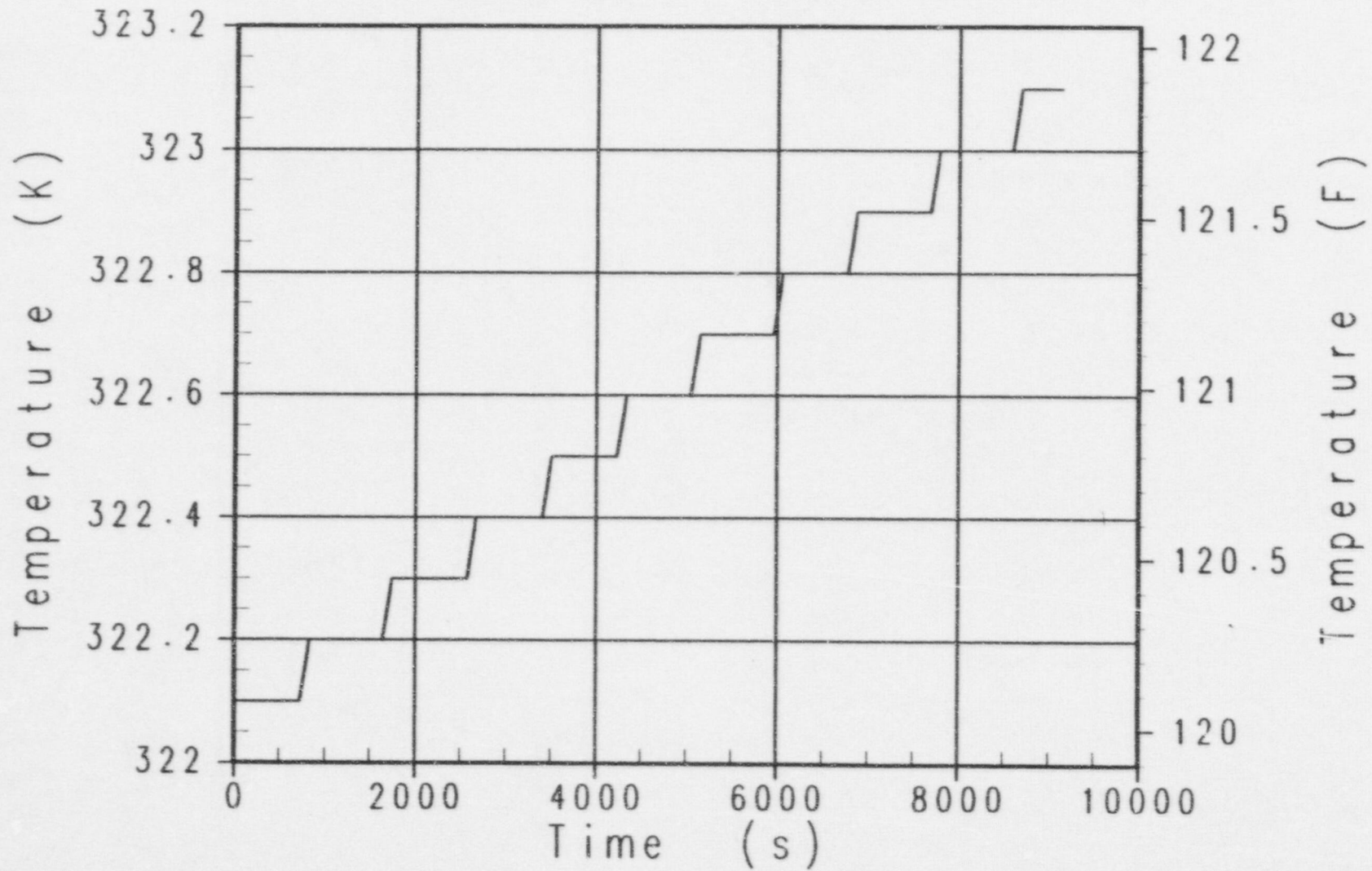

Case m3g AP600 Success Criteria MAAP4 Analysis
Accumulator and NRHR Injection Flowrate

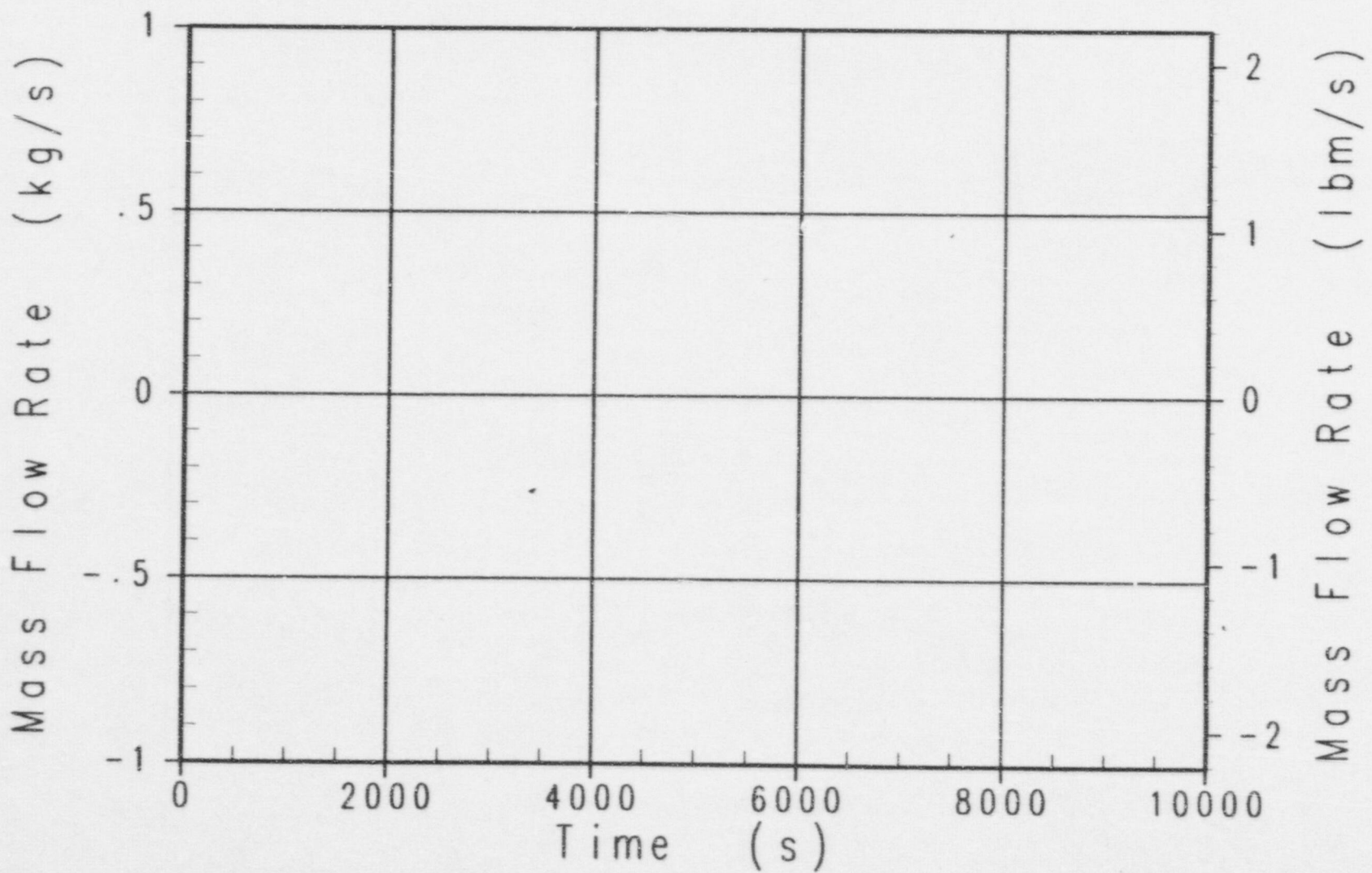

Case m3g AP600 Success Criteria MAAP4 Analysis
RCS Break Gas Flowrate

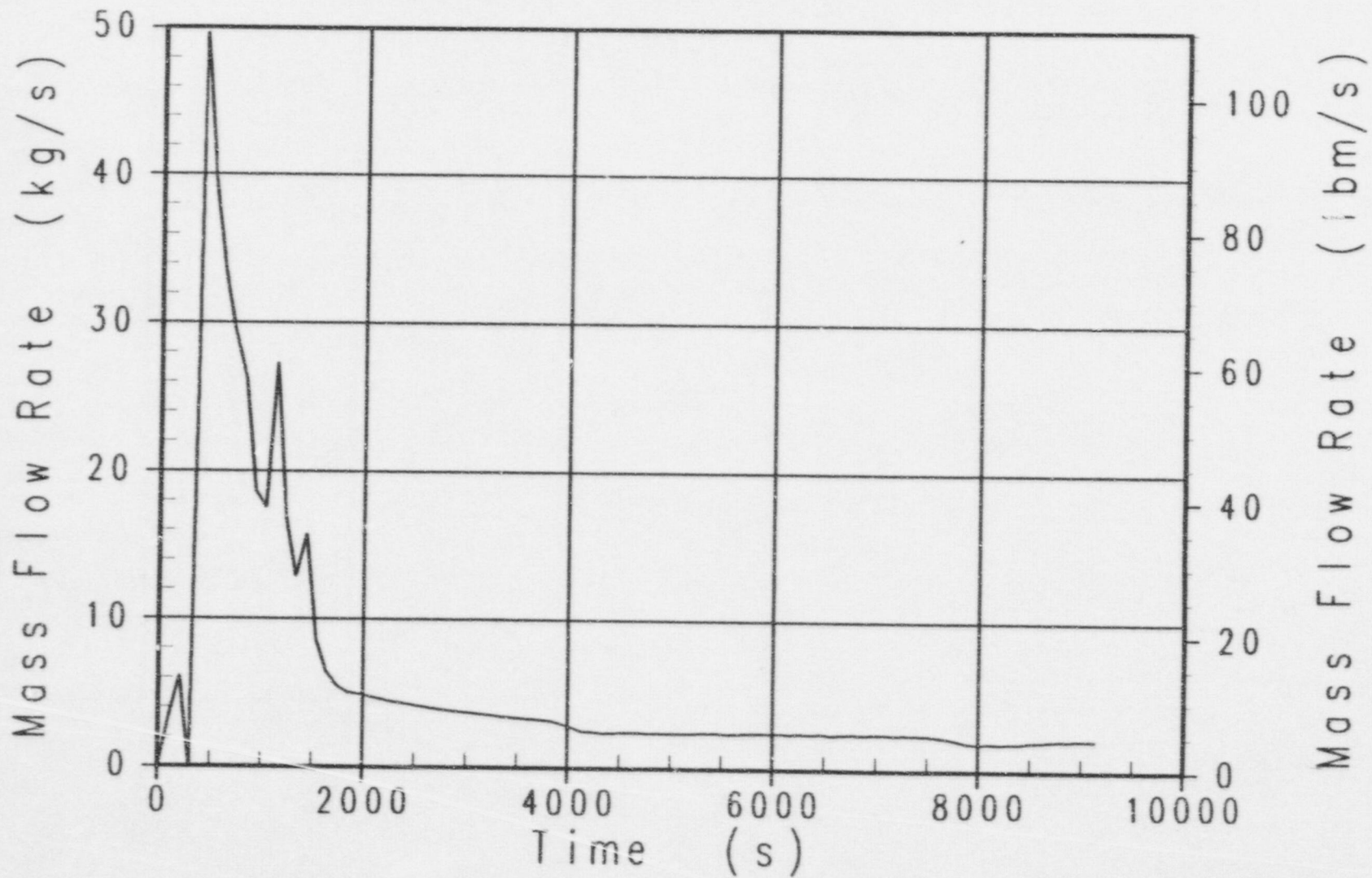

Case m3g AP600 Success Criteria MAAP4 Analysis
ADS Stage 4 Gas Flowrate

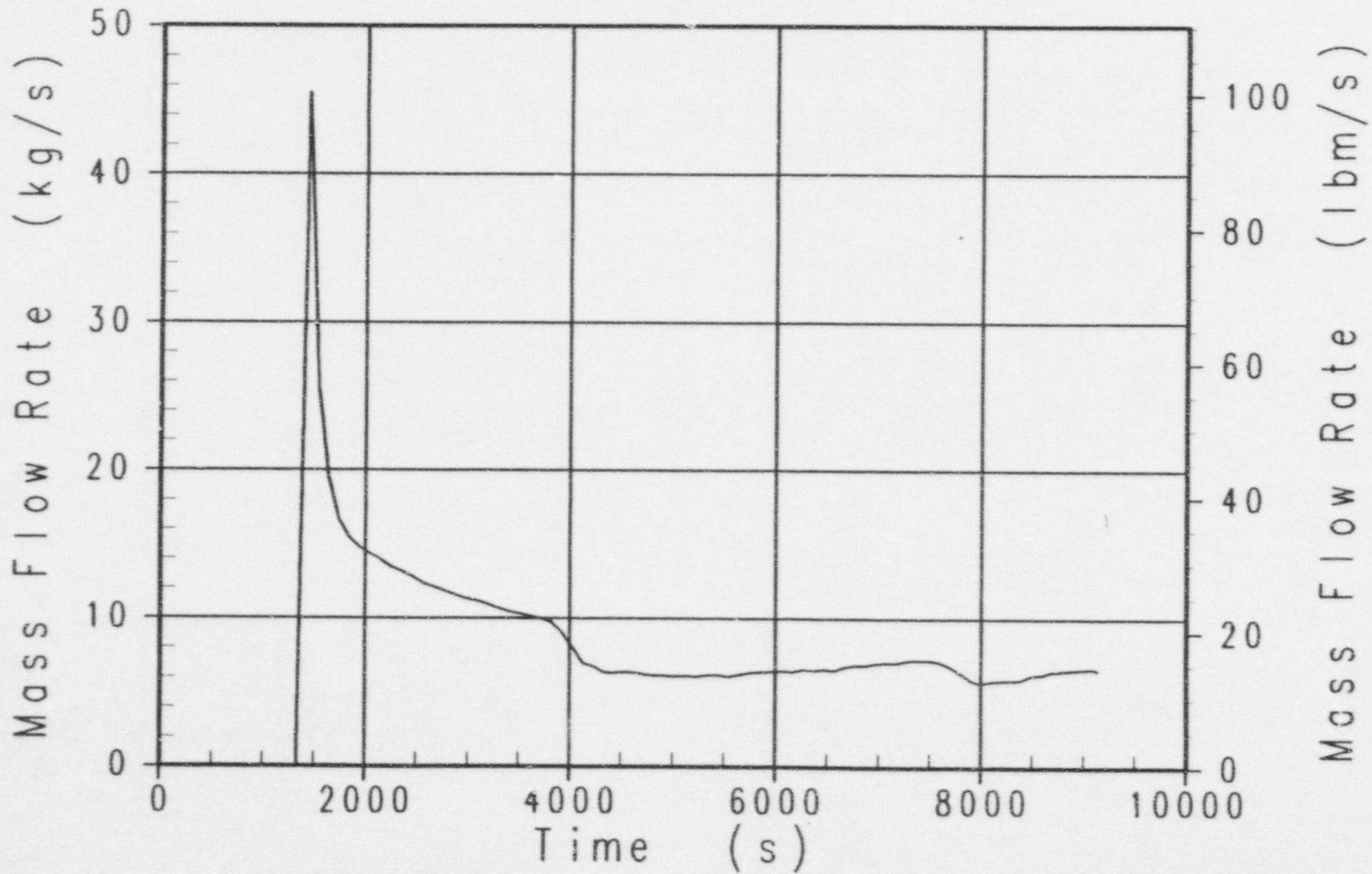

Case m3g AP600 Success Criteria MAAP4 Analysis
Safety Valve and ADS Stages 1-3 Gas Flowrate

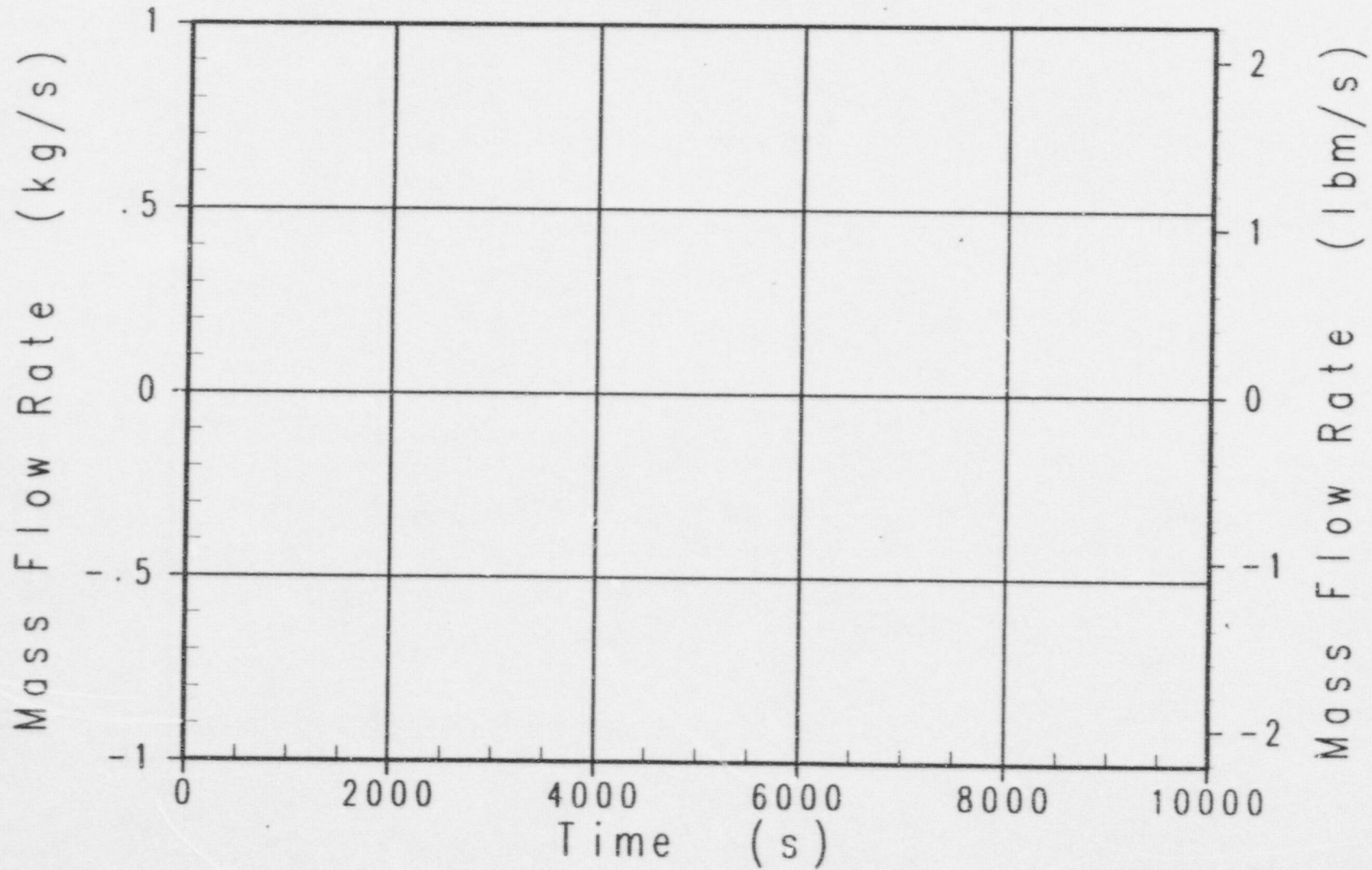

Case m3g AP600 Success Criteria MAAP4 Analysis
RCS Break Liquid Flowrate

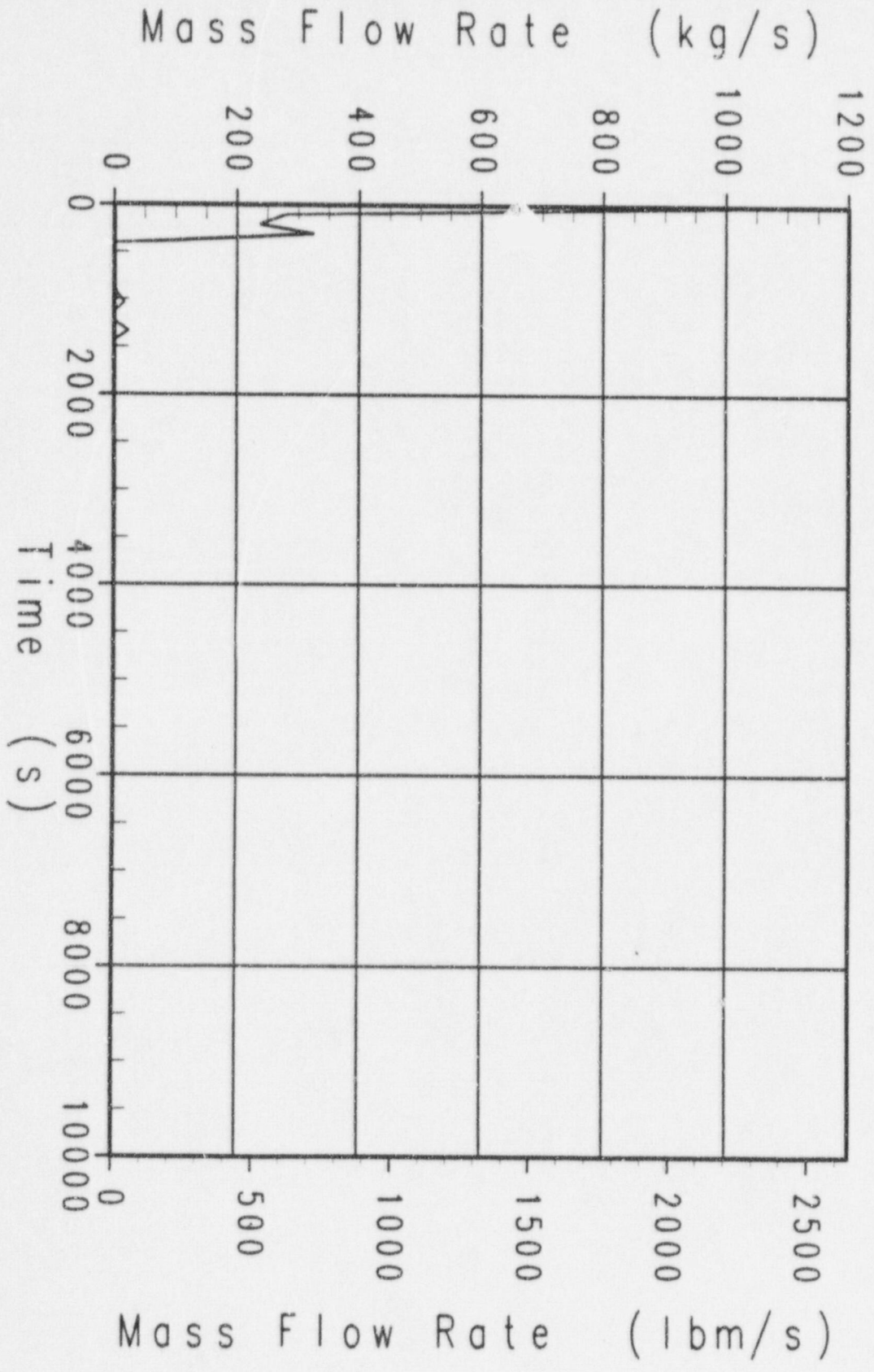

Case m3g AP600 Success Criteria MAAP4 Analysis
ADS Stage 4 Liquid Flowrate

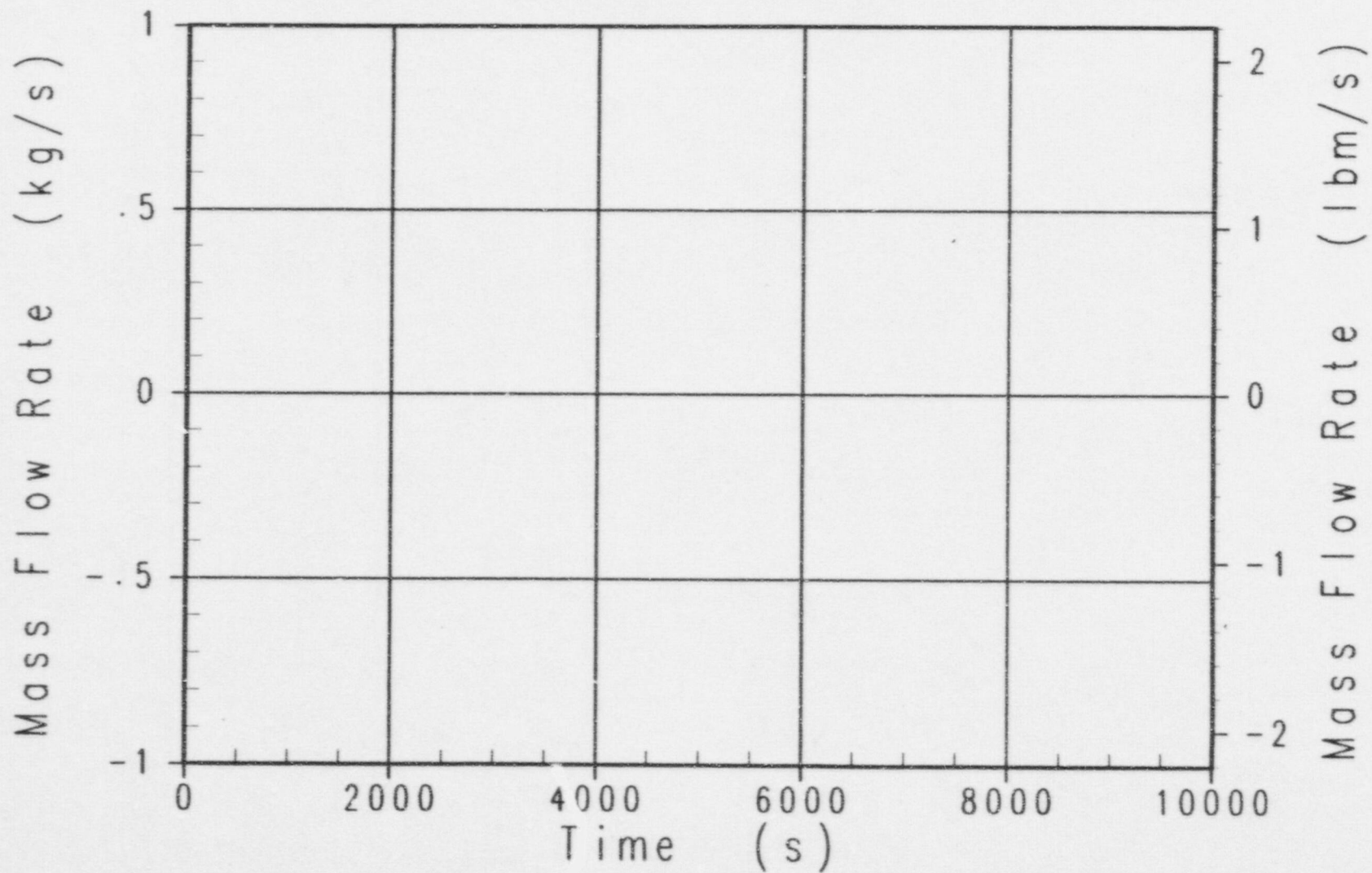

Case m3g AP600 Success Criteria MAAP4 Analysis
IRWST Injection Flowrate (neg. means into RCS)

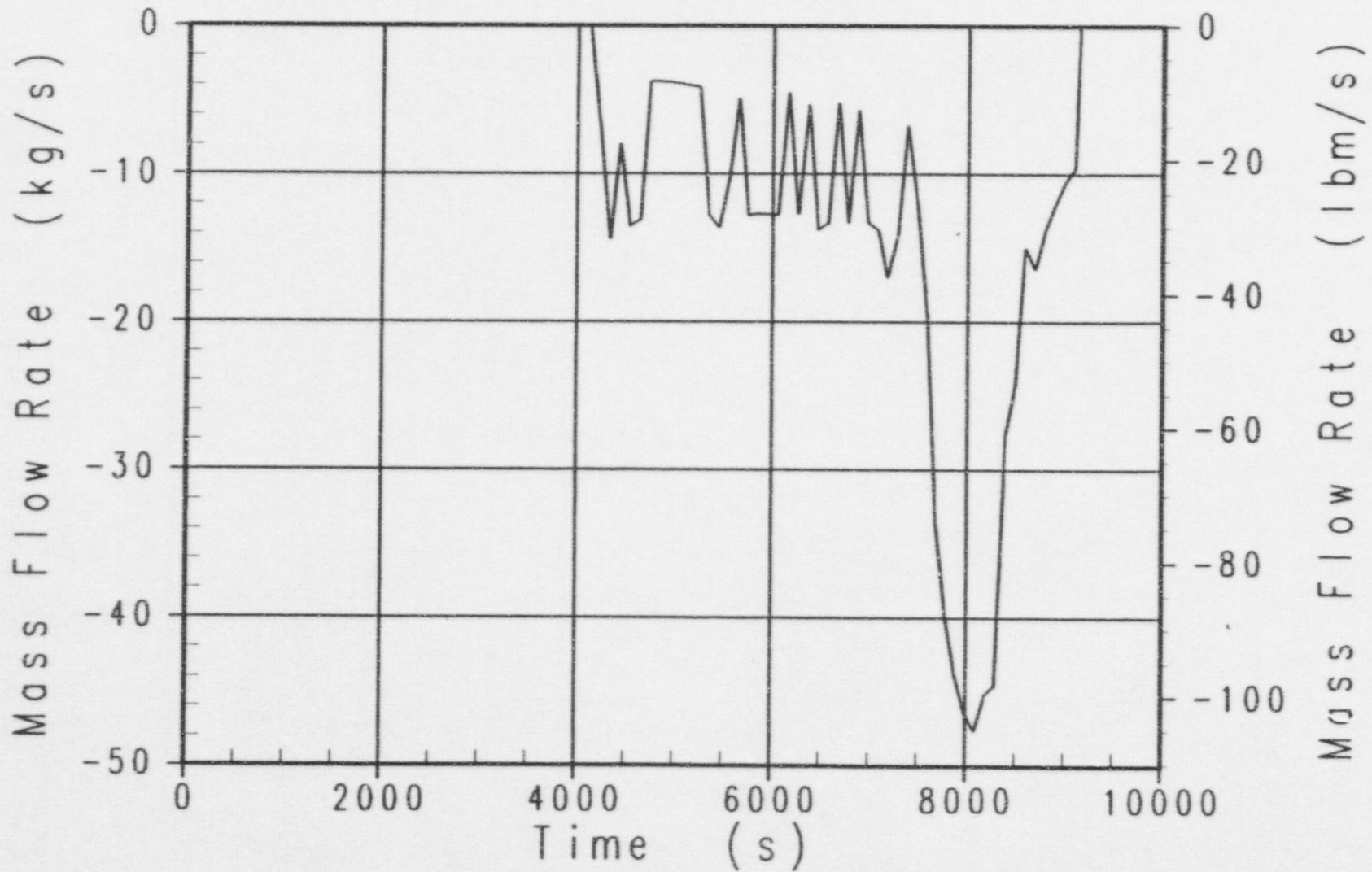

Case m3g AP600 Success Criteria MAAP4 Analysis
CMT-1 Injection Flowrate

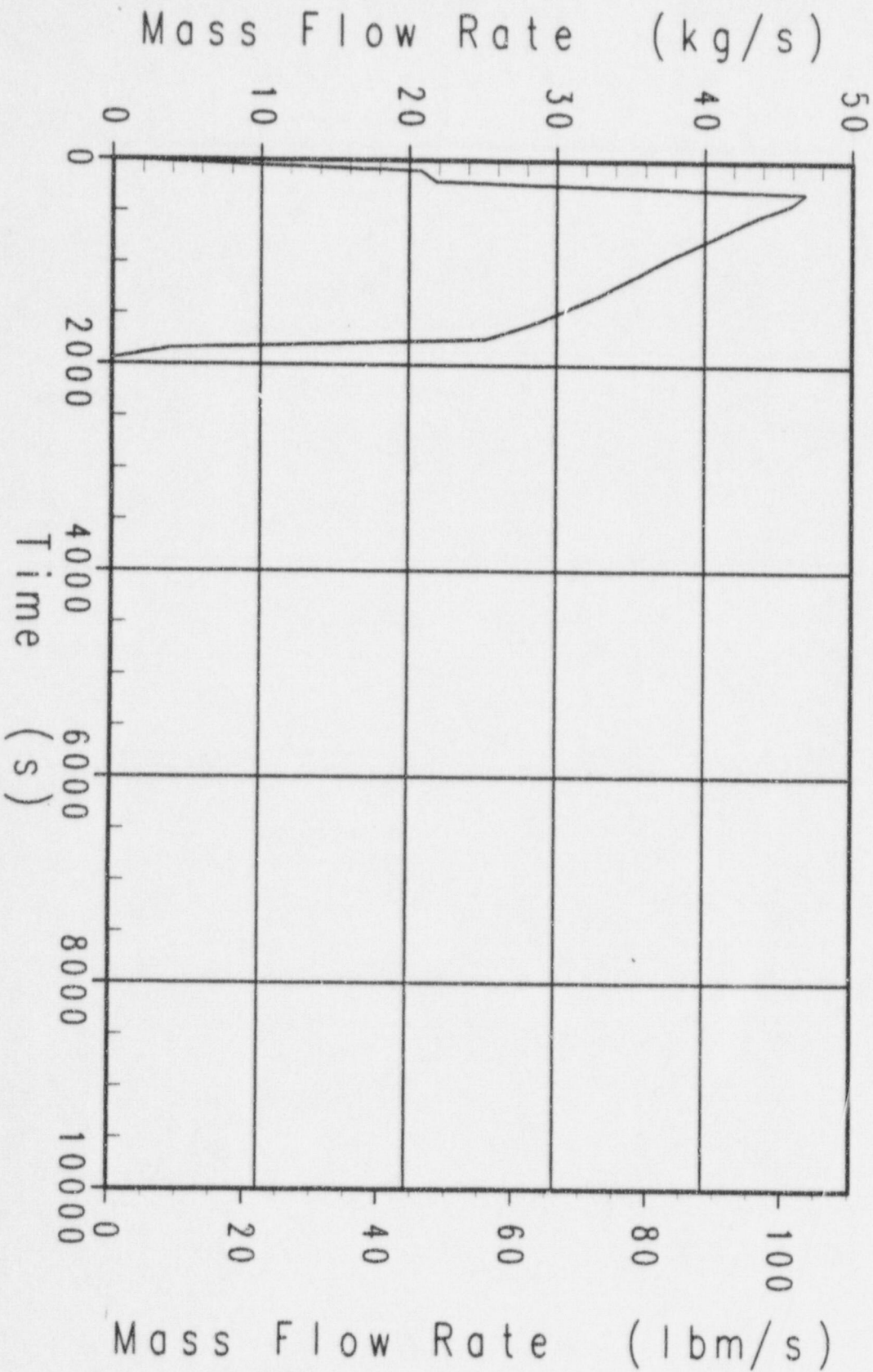

Case m3g AP600 Success Criteria MAAP4 Analysis
Safety Valve and ADS Stages 1-3 Liquid Flowrate

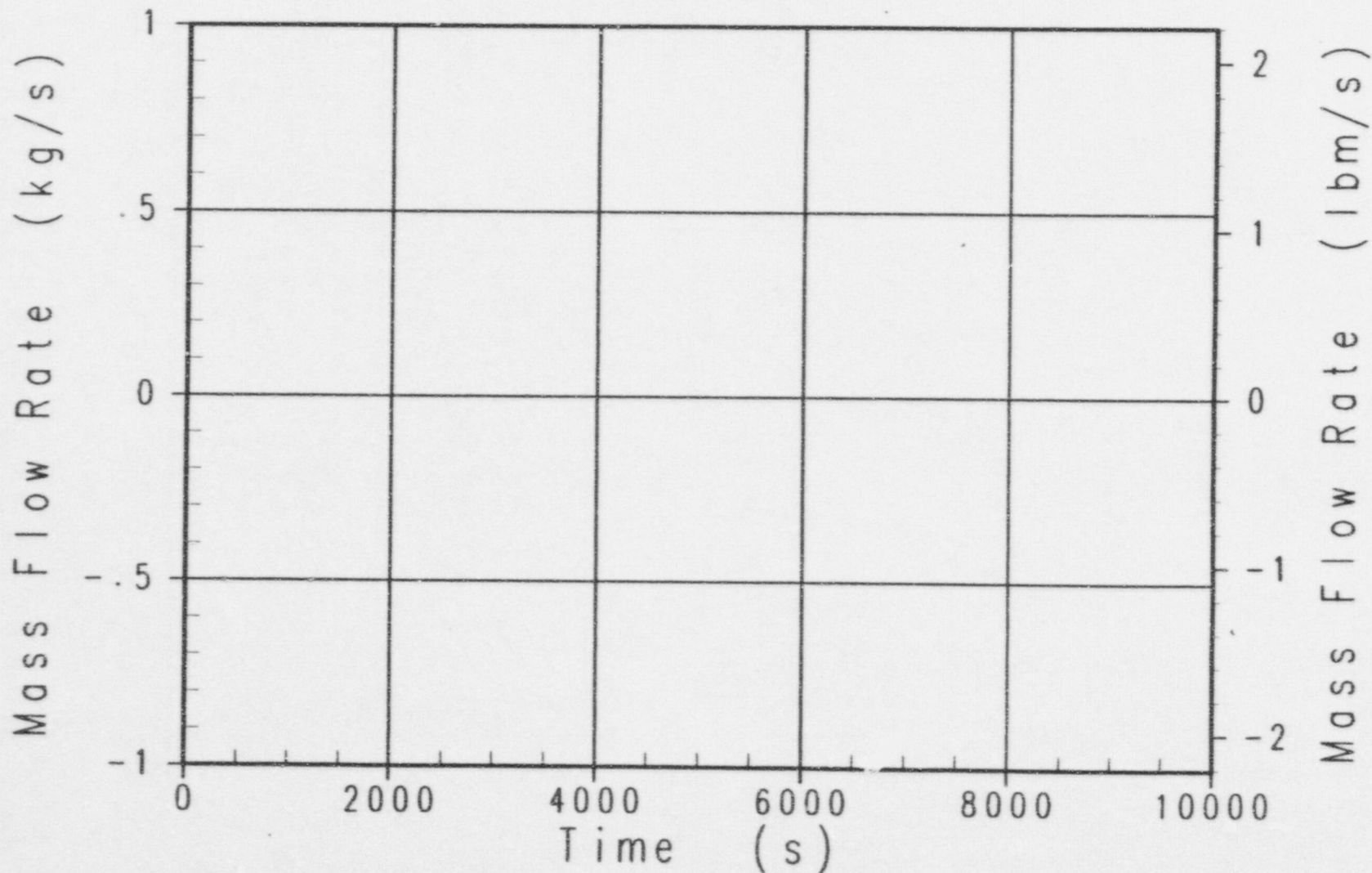

Case m3g AP600 Success Criteria MAAP4 Analysis
CMT-1 Water Level

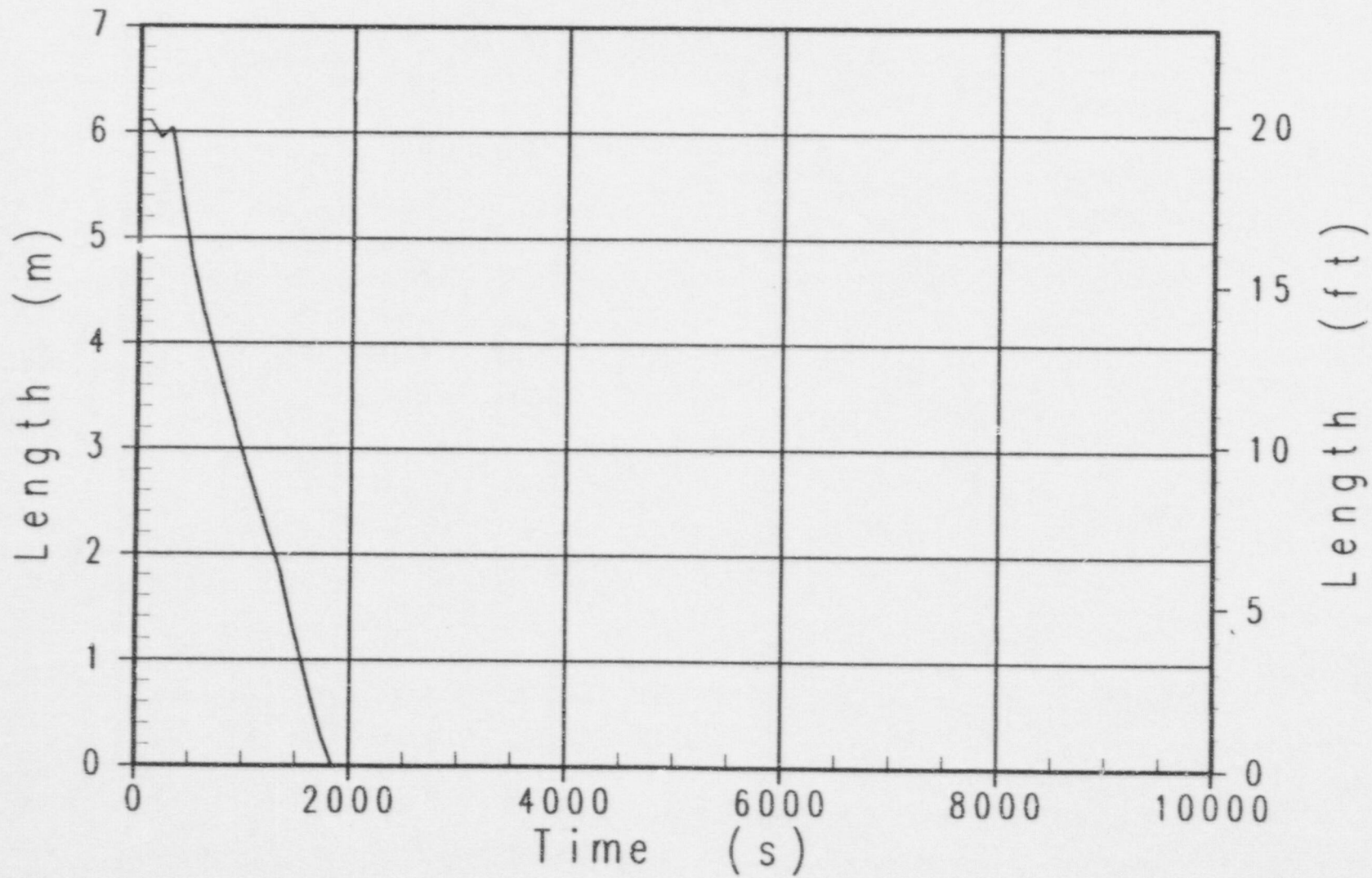

Case m3g AP600 Success Criteria MAAP4 Analysis
Pressurizer Water Level (From Pzr Bottom)

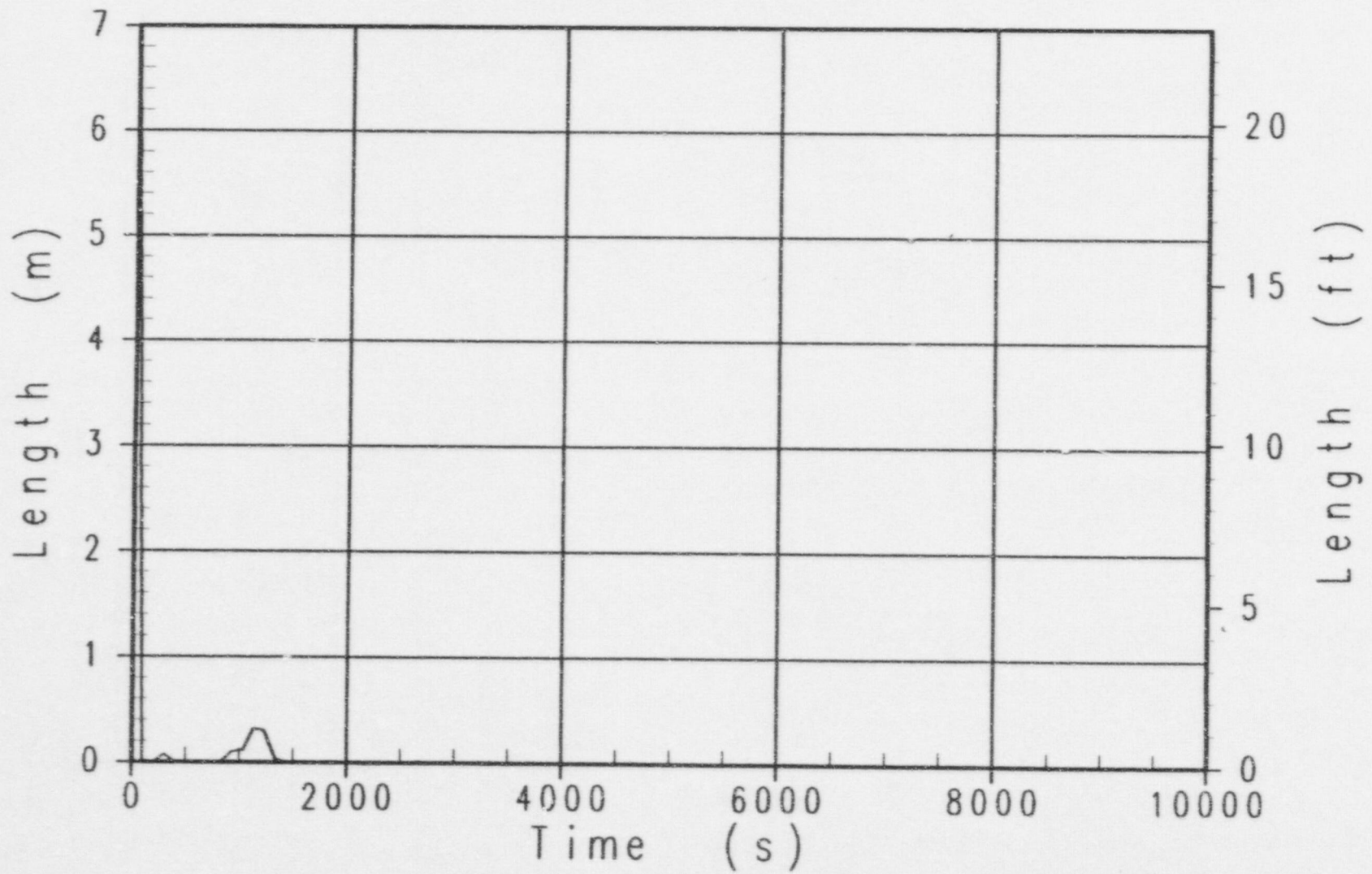

Case m6a AP600 Success Criteria MAAP4 Analysis
Broken Loop Steam Generator Pressure

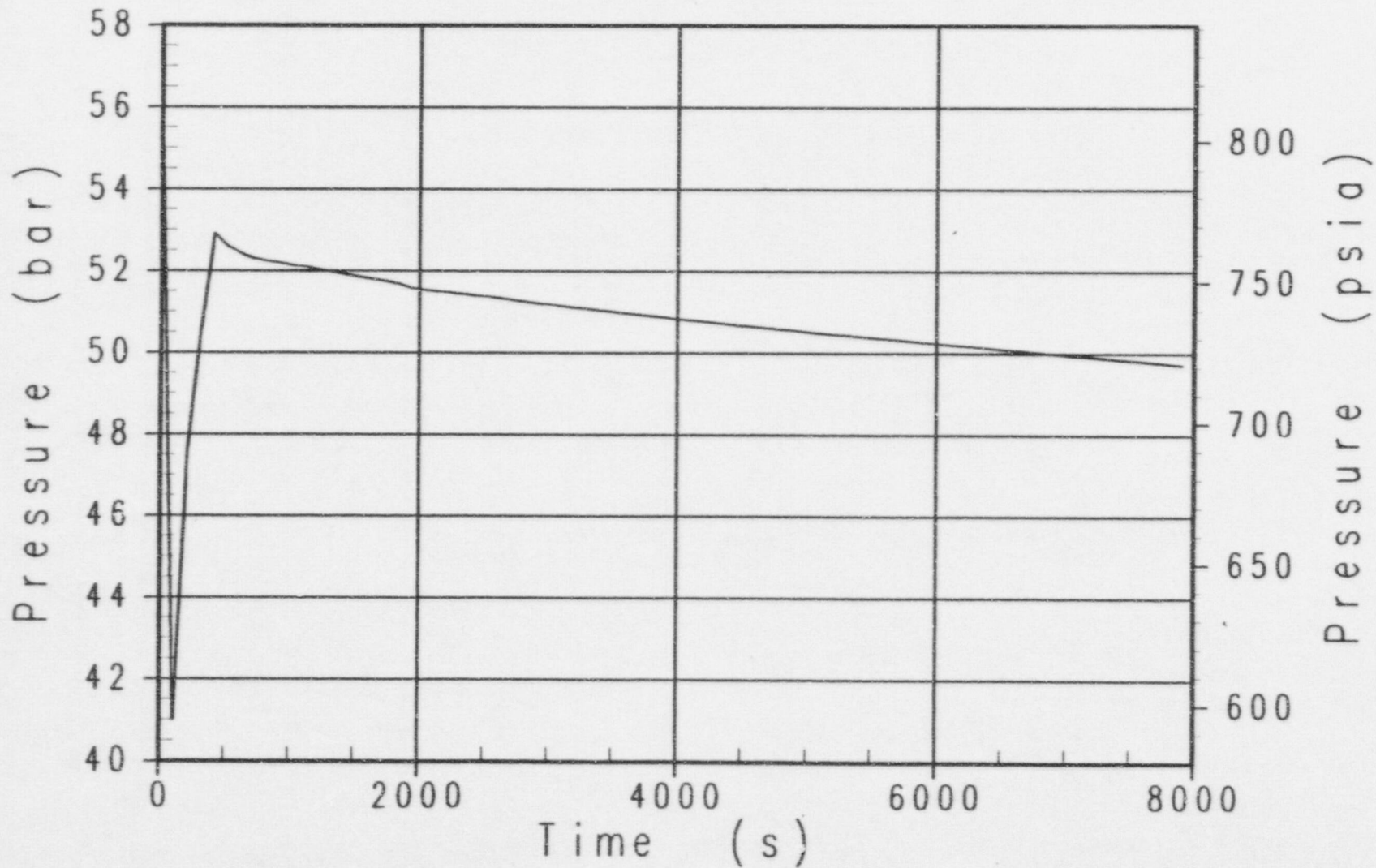

Case m6a AP600 Success Criteria MAAP4 Analysis
Primary System Pressure

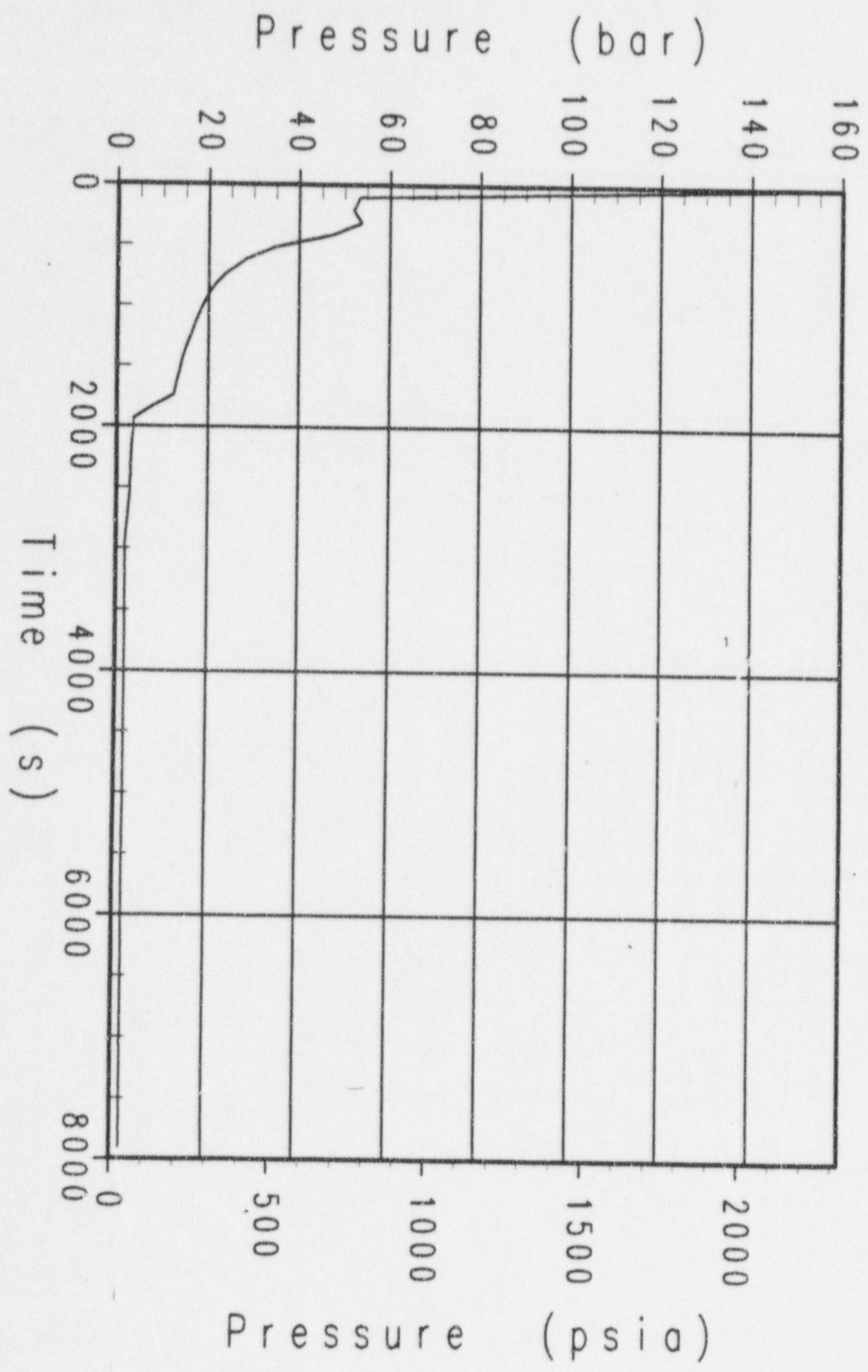

Case m6a AP600 Success Criteria MAAP4 Analysis
Containment Pressure

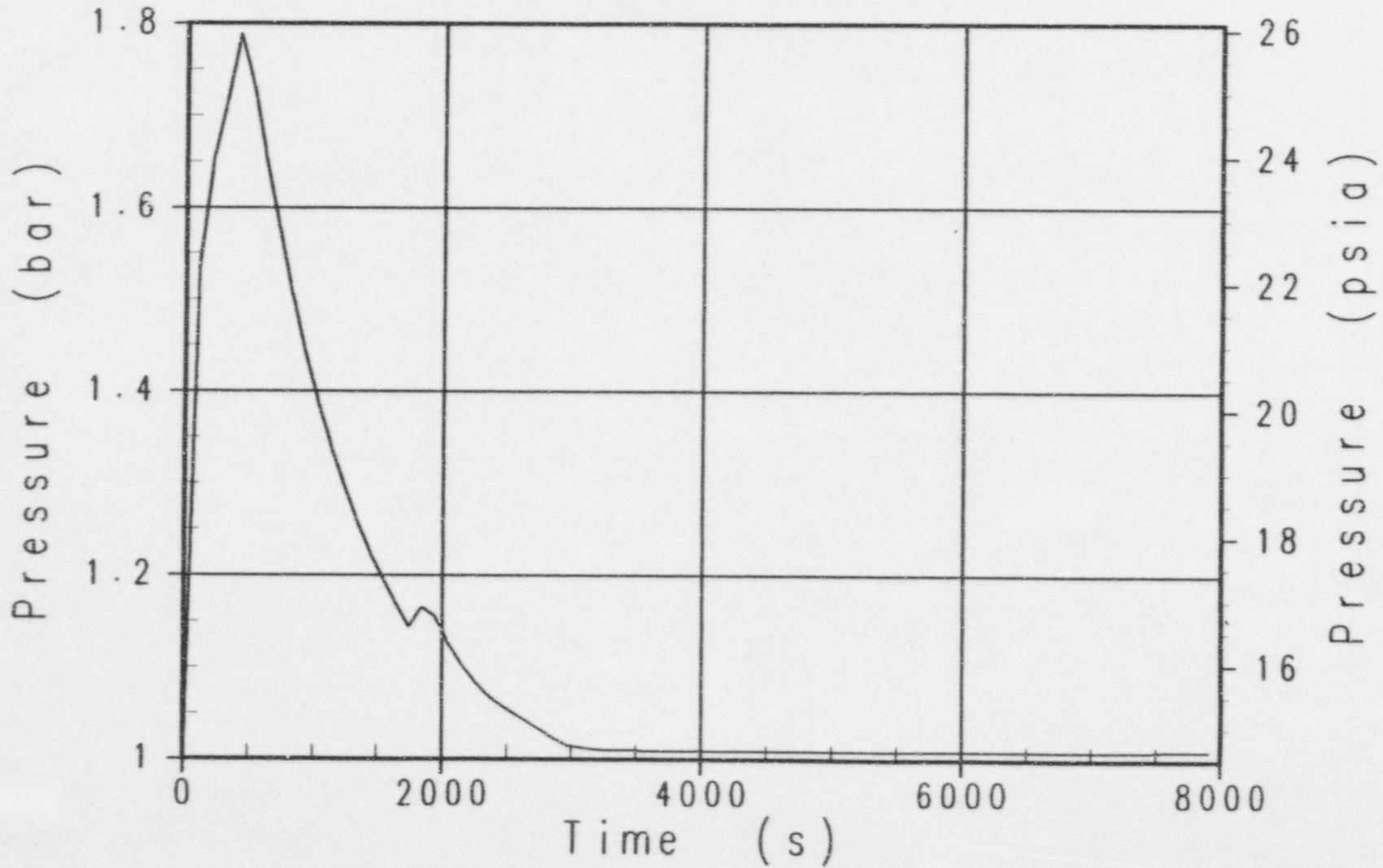

Case m6a AP600 Success Criteria MAAP4 Analysis
Unbroken Loop Steam Generator Pressure

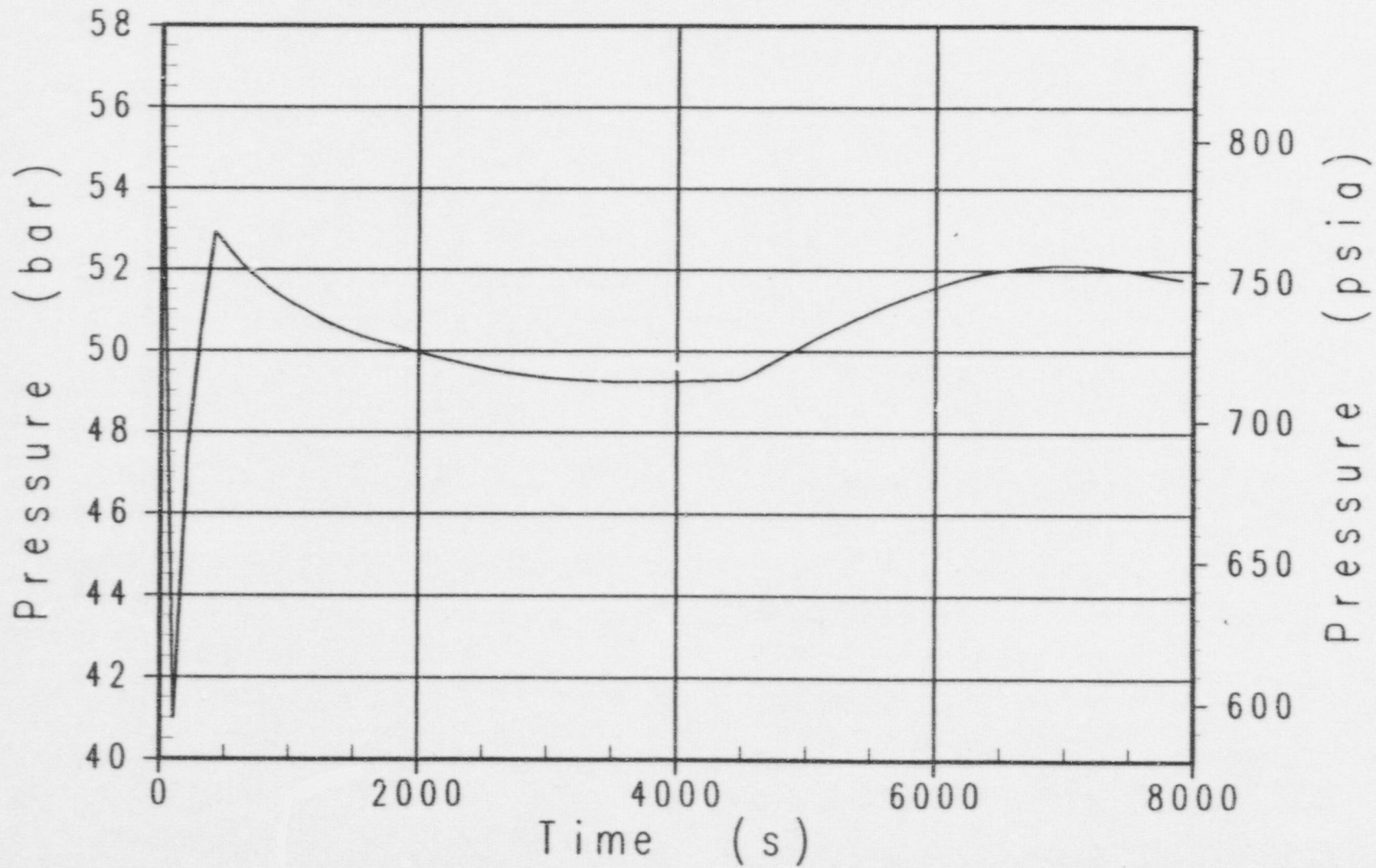

Case m6a AP600 Success Criteria MAAP4 Analysis
RCS Break Gas Flowrate

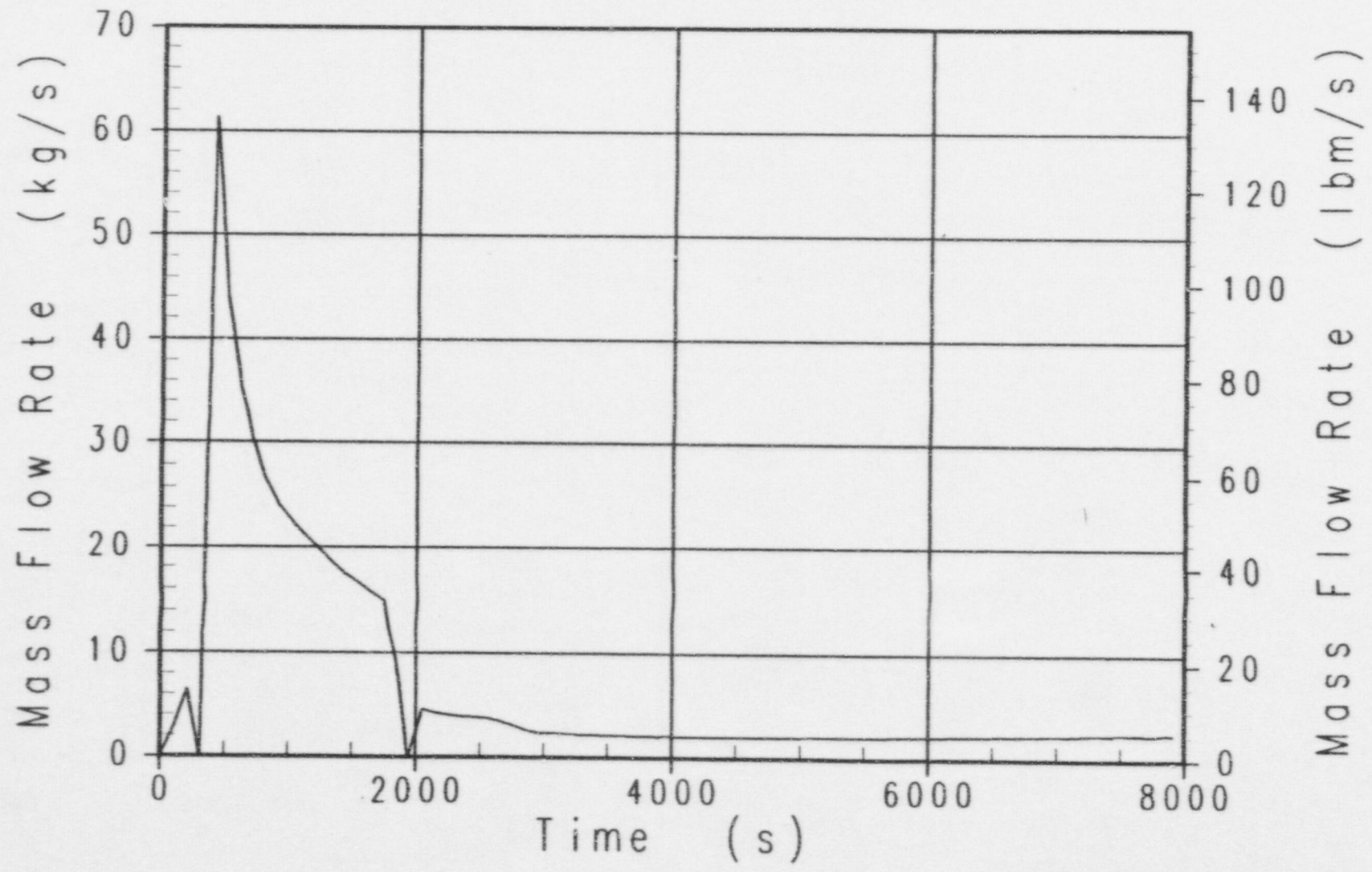

Case m6a AP600 Success Criteria MAAP4 Analysis
Decay Power

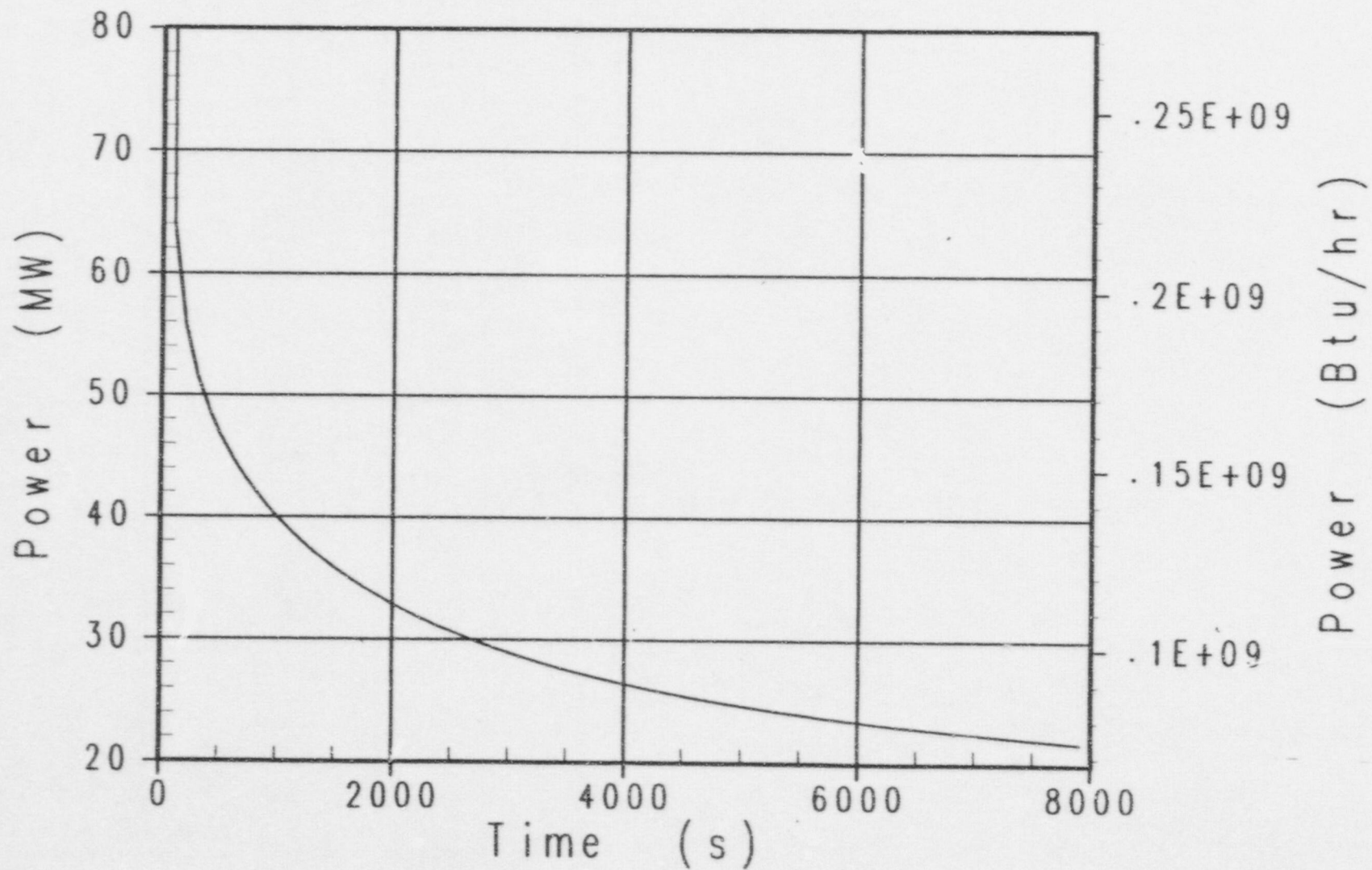

Case m6a AP600 Success Criteria MAAP4 Analysis
PRHR Heat Removal Rate

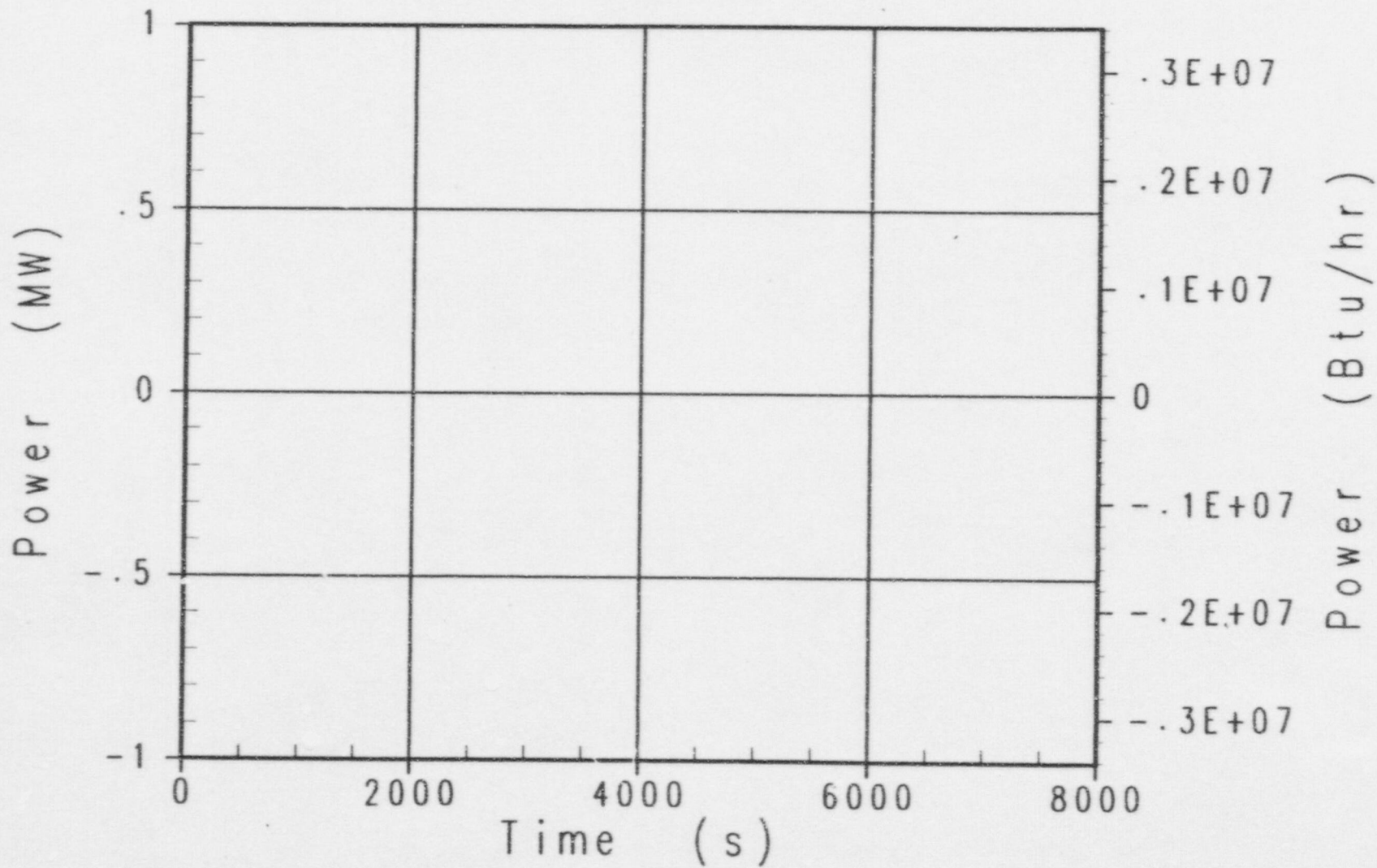

Case m6a AP600 Success Criteria MAAP4 Analysis
Peak Temperature in the Core

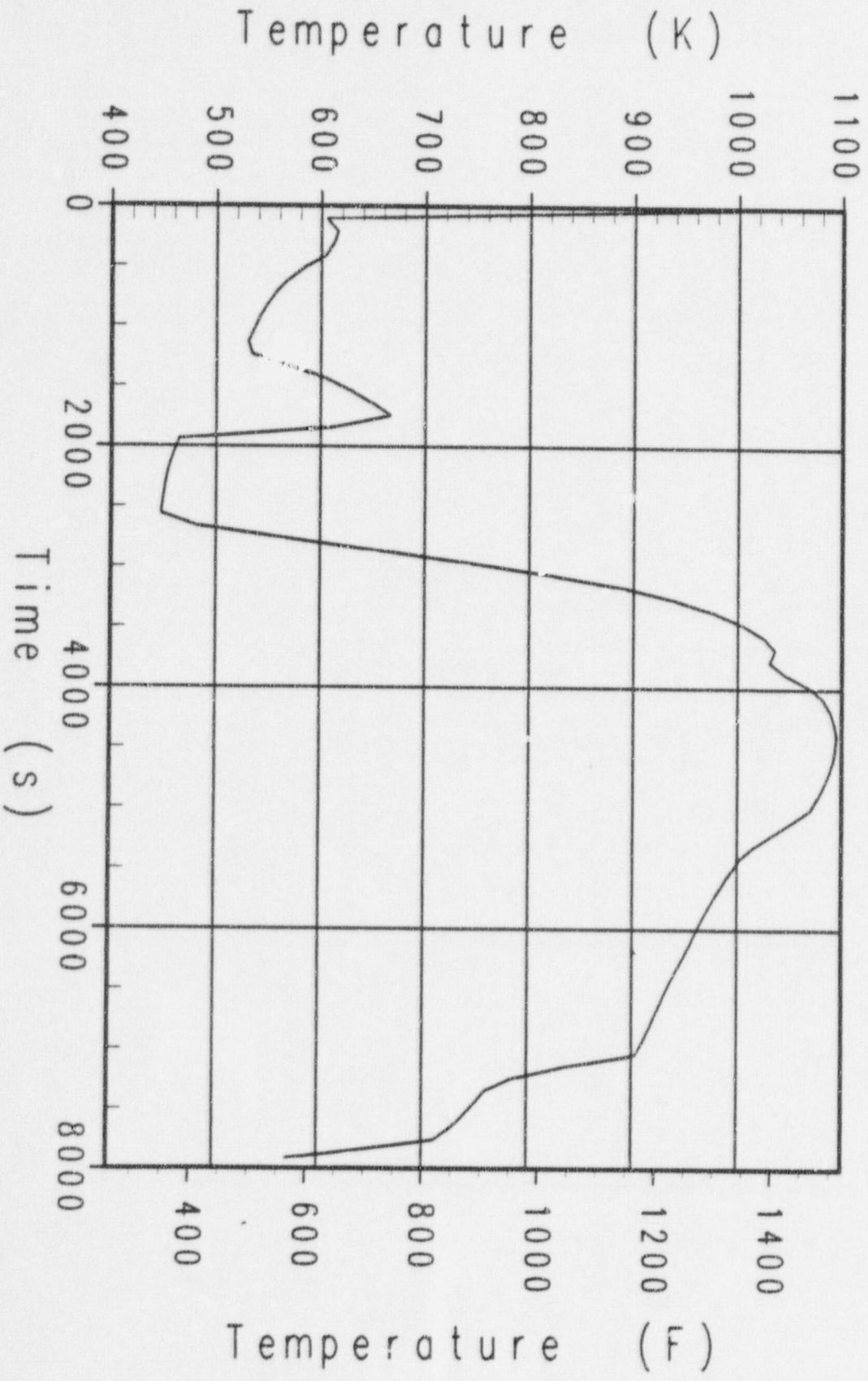

Case m6a AP600 Success Criteria MAAP4 Analysis
Cold Leg Water Temperature

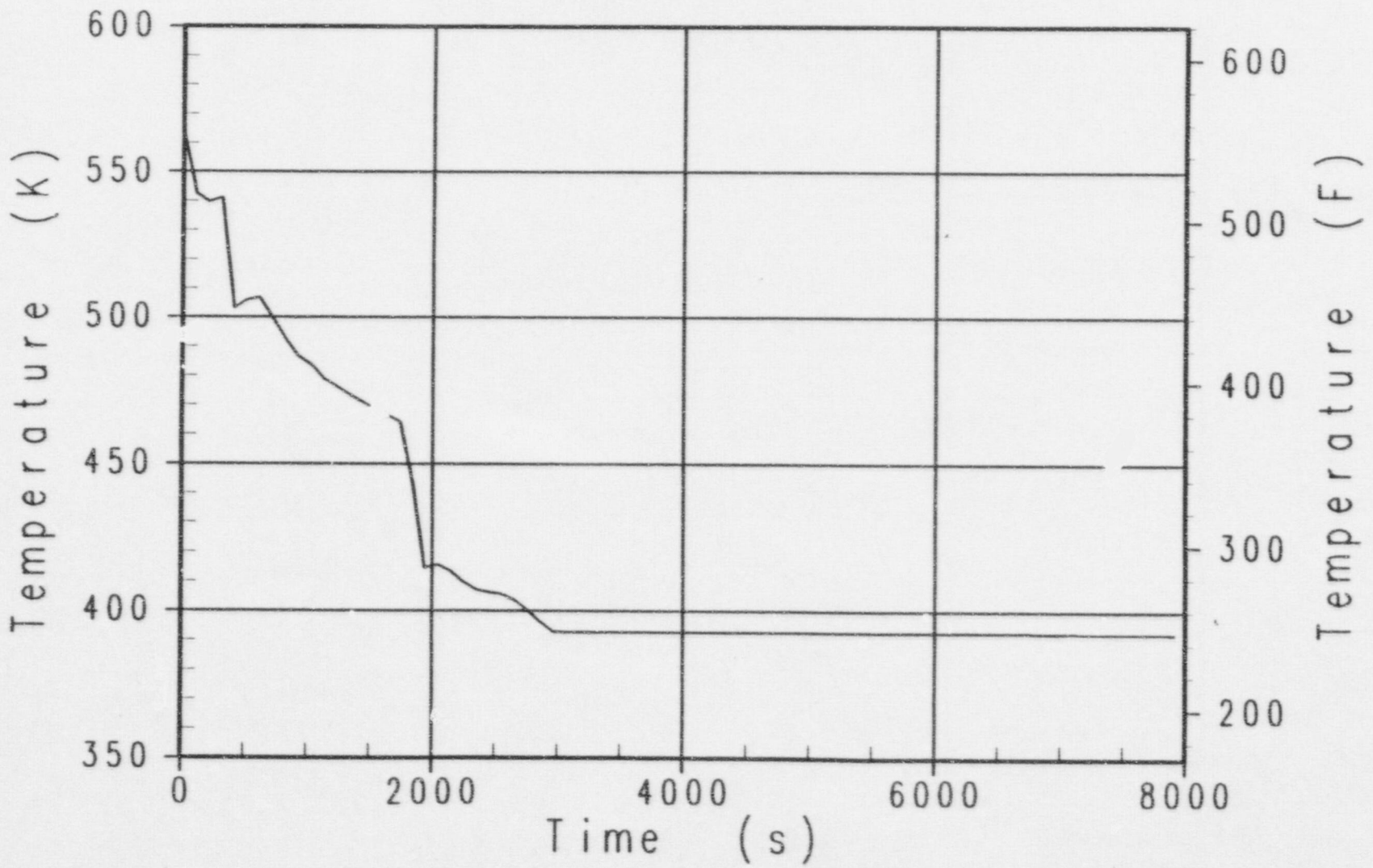

Case m6a AP600 Success Criteria MAAP4 Analysis
Core Water Temperature

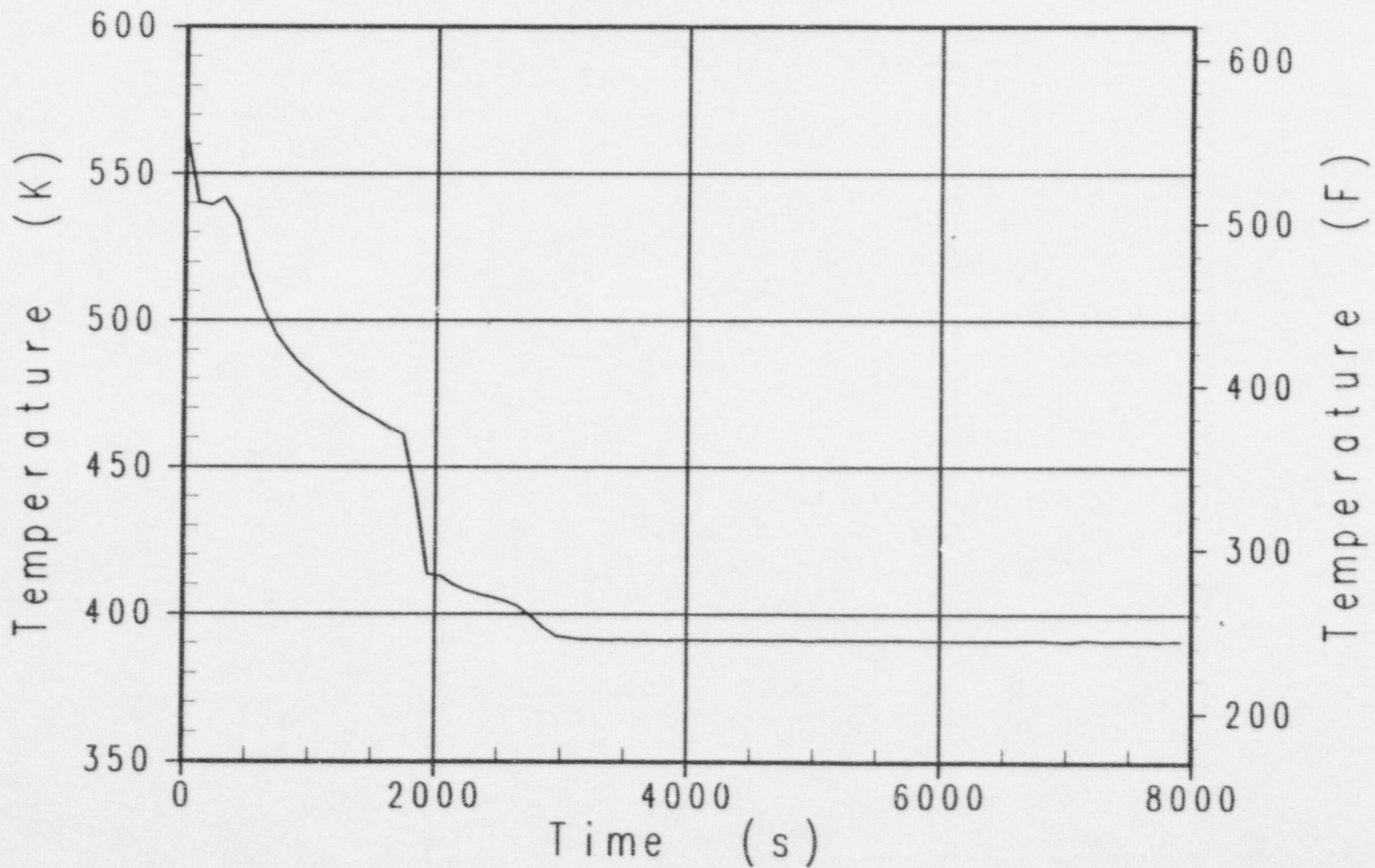

Case m6a AP600 Success Criteria MAAP4 Analysis
RPV Downcomer Water Temperature

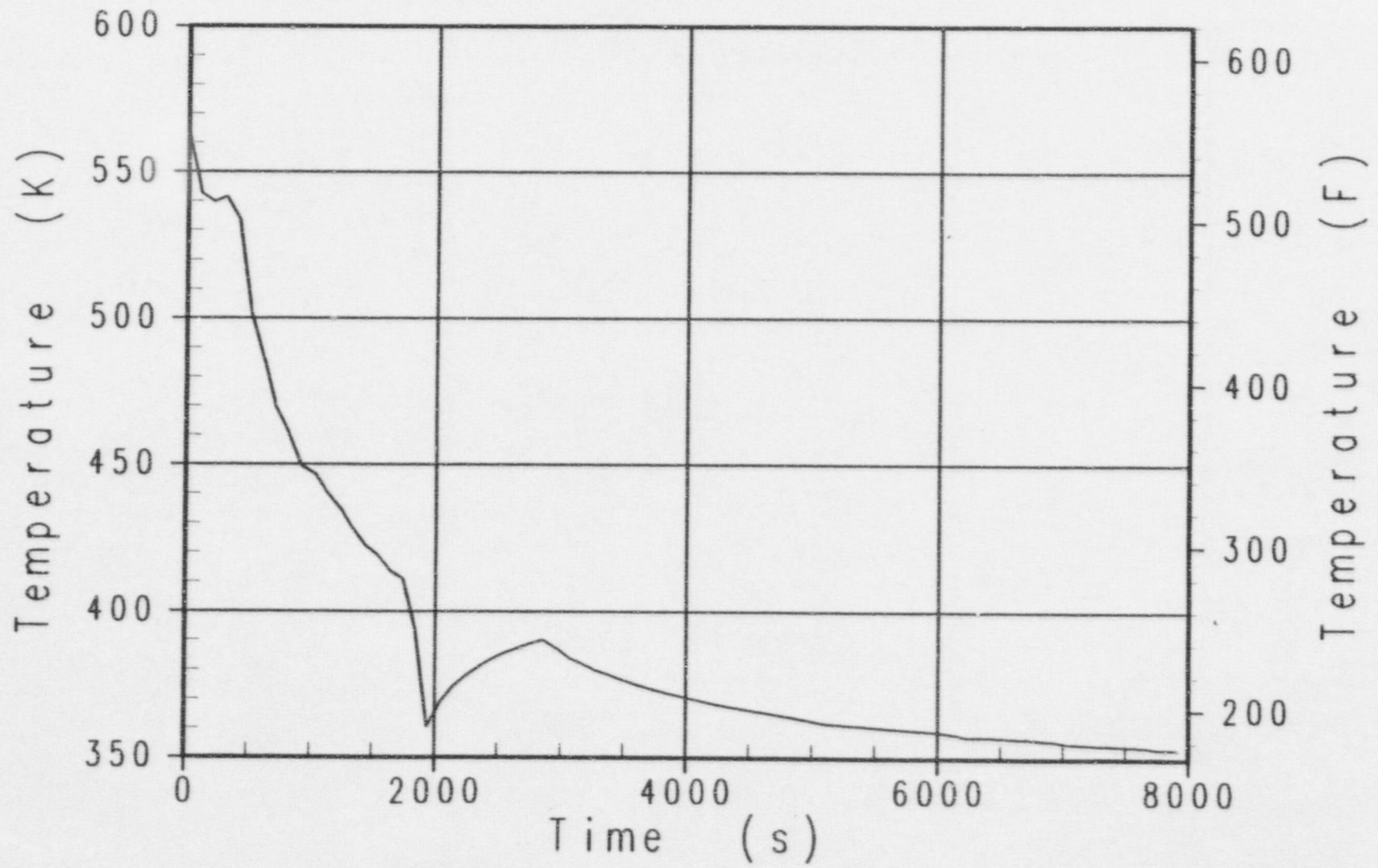

Case m6a AP600 Success Criteria MAAP4 Analysis
IRWST Water Temperature

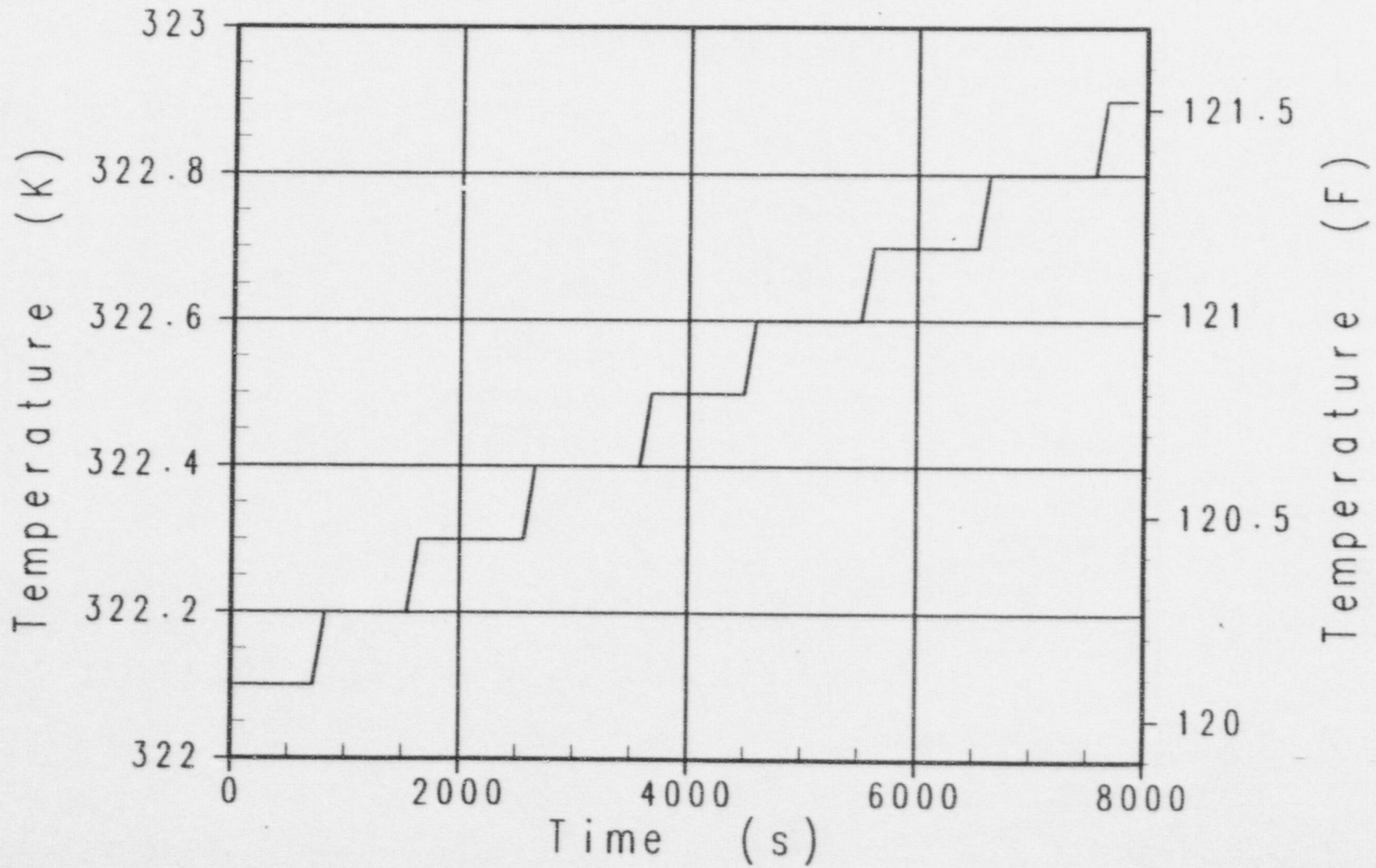

Case m6a AP600 Success Criteria MAAP4 Analysis
Accumulator and NRHR Injection Flowrate

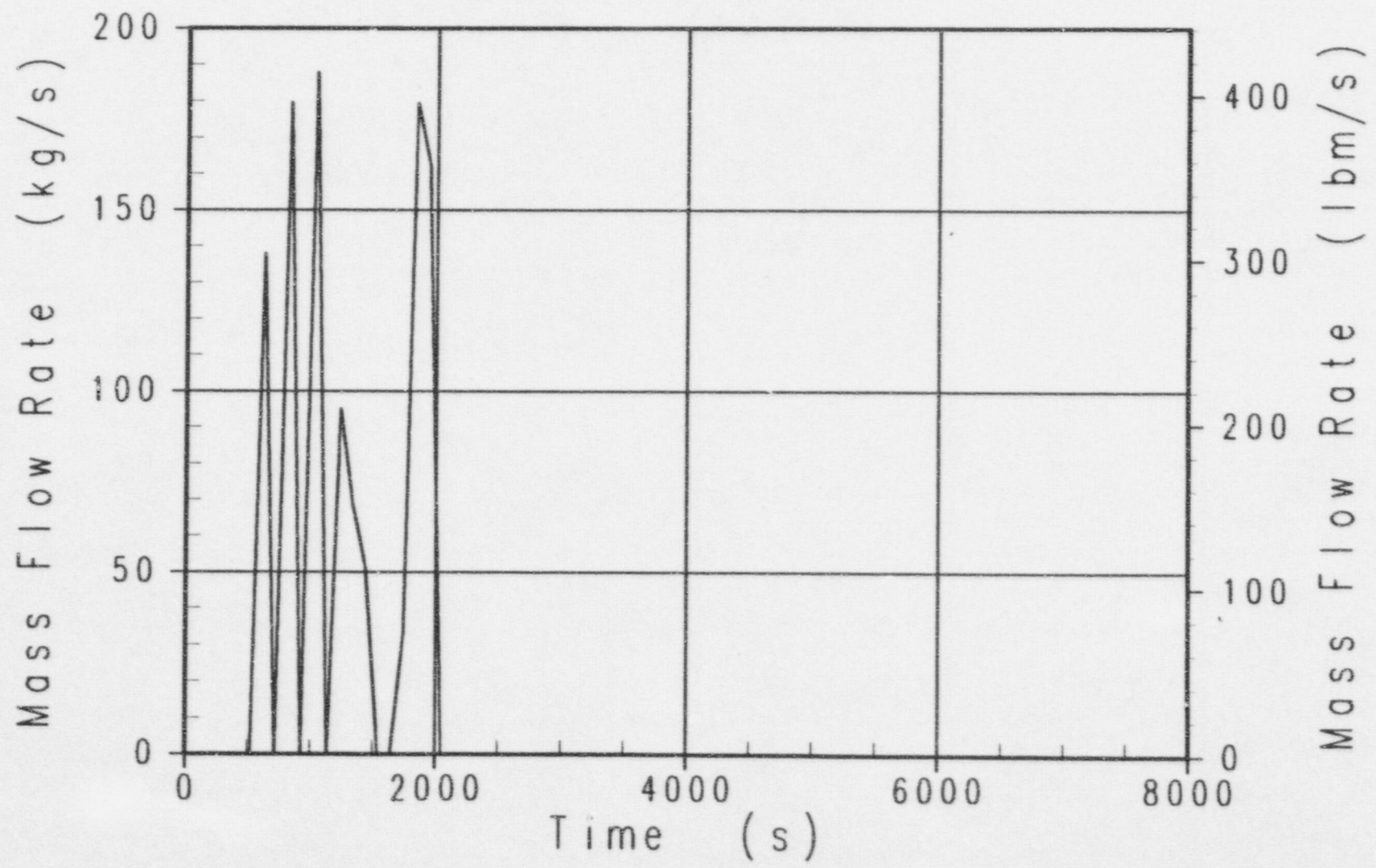

Case m6a AP600 Success Criteria MAAP4 Analysis
ADS Stage 4 Gas Flowrate

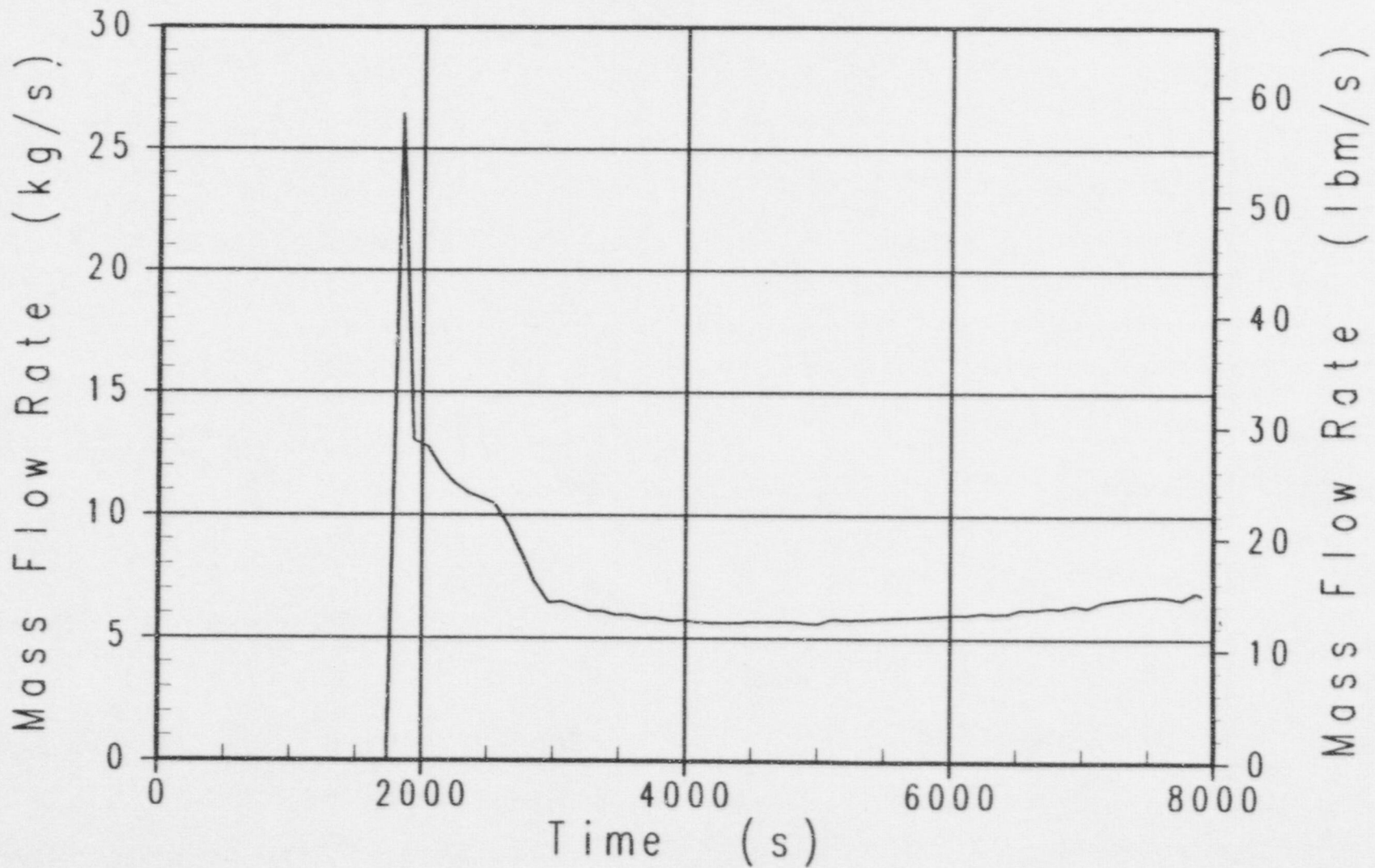

Case m6a AP600 Success Criteria MAAP4 Analysis
Safety Valve and ADS Stages 1-3 Gas Flowrate

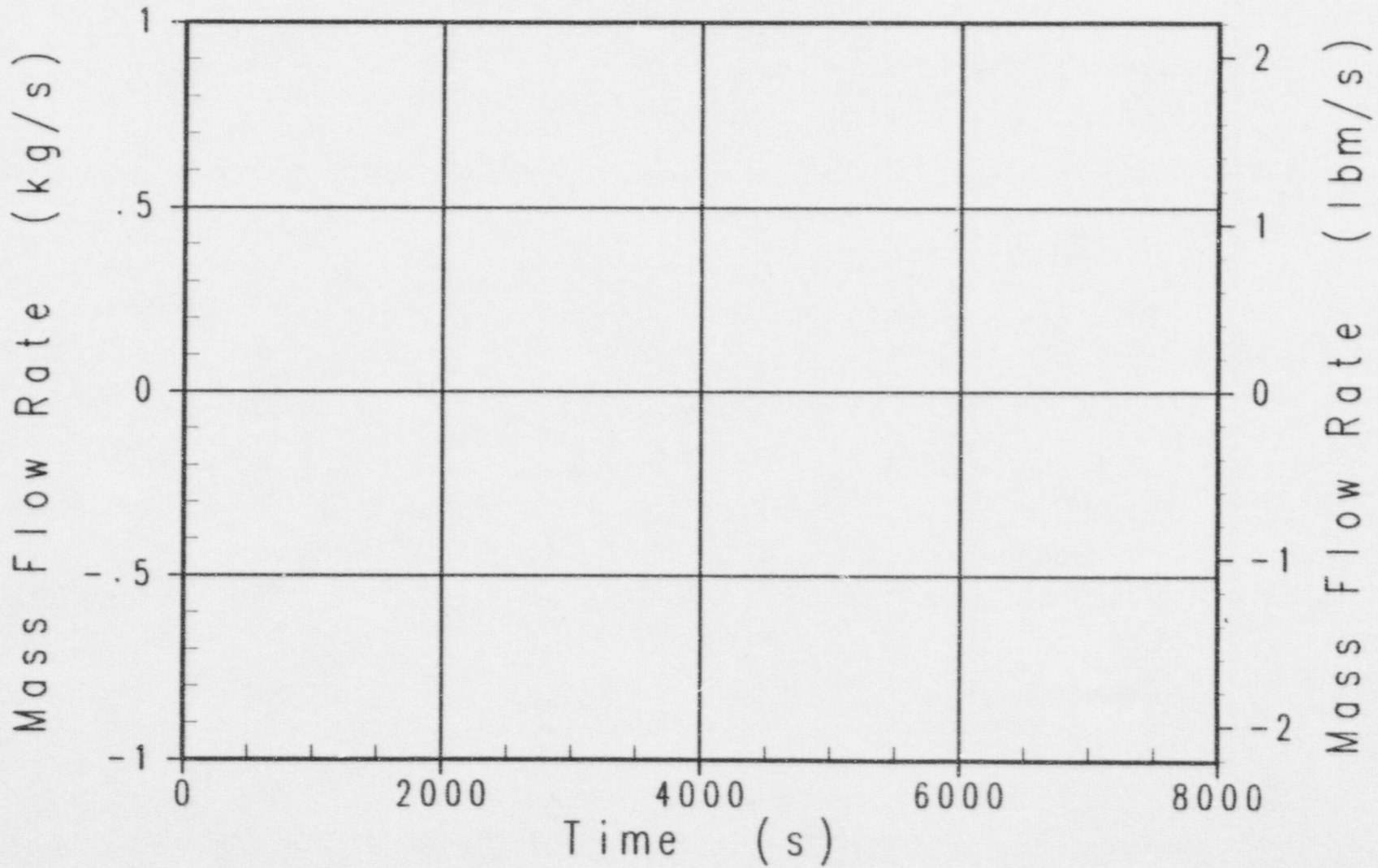

Case m6a AP600 Success Criteria MAAP4 Analysis
RCS Break Liquid Flowrate

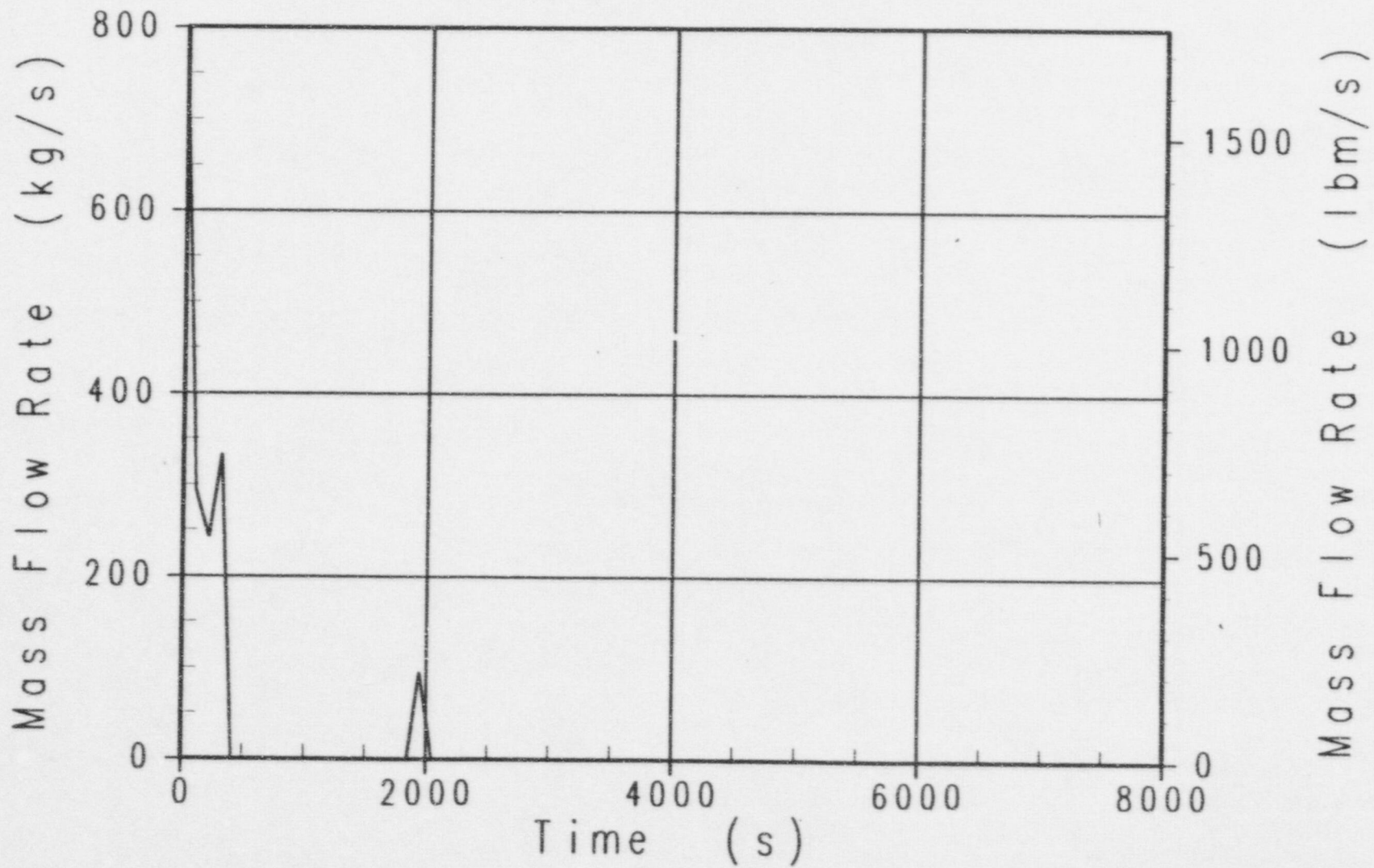

Case m6a AP600 Success Criteria MAAP4 Analysis
ADS Stage 4 Liquid Flowrate

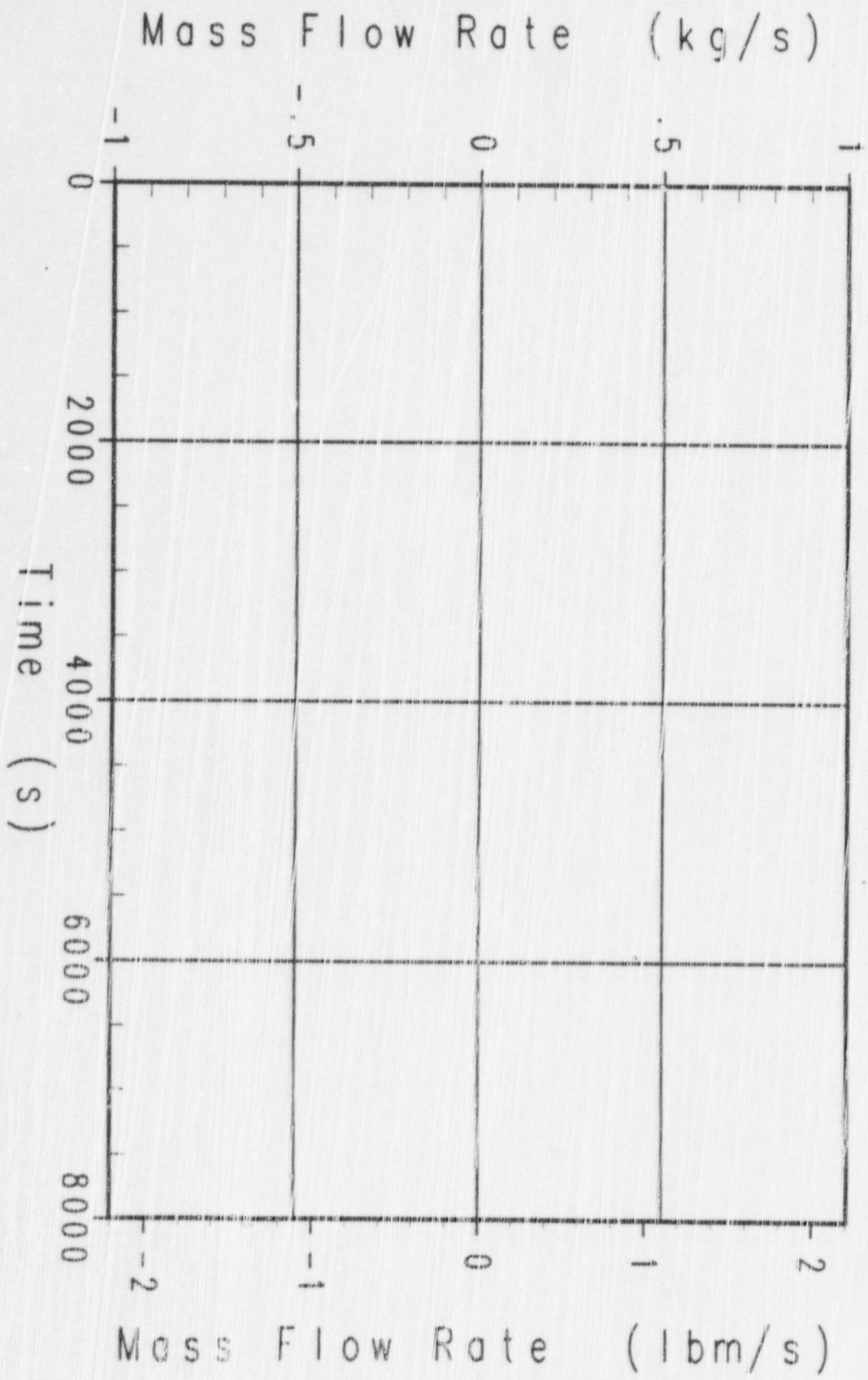

Case m6a AP600 Success Criteria MAAP4 Analysis
IRWST Injection Flowrate (neg. means into RCS)

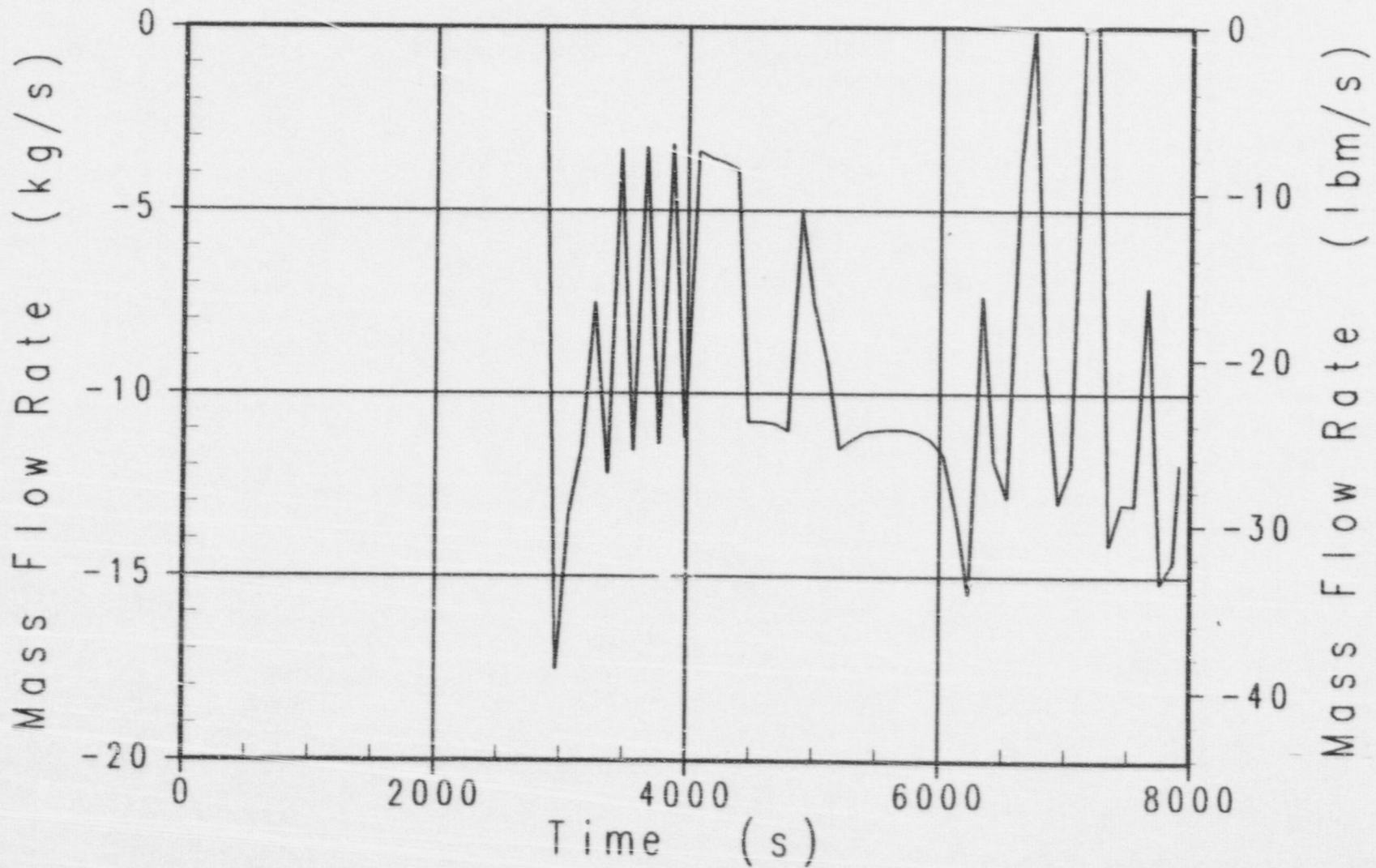

Case m6a AP600 Success Criteria MAAP4 Analysis
CMT-1 Injection Flowrate

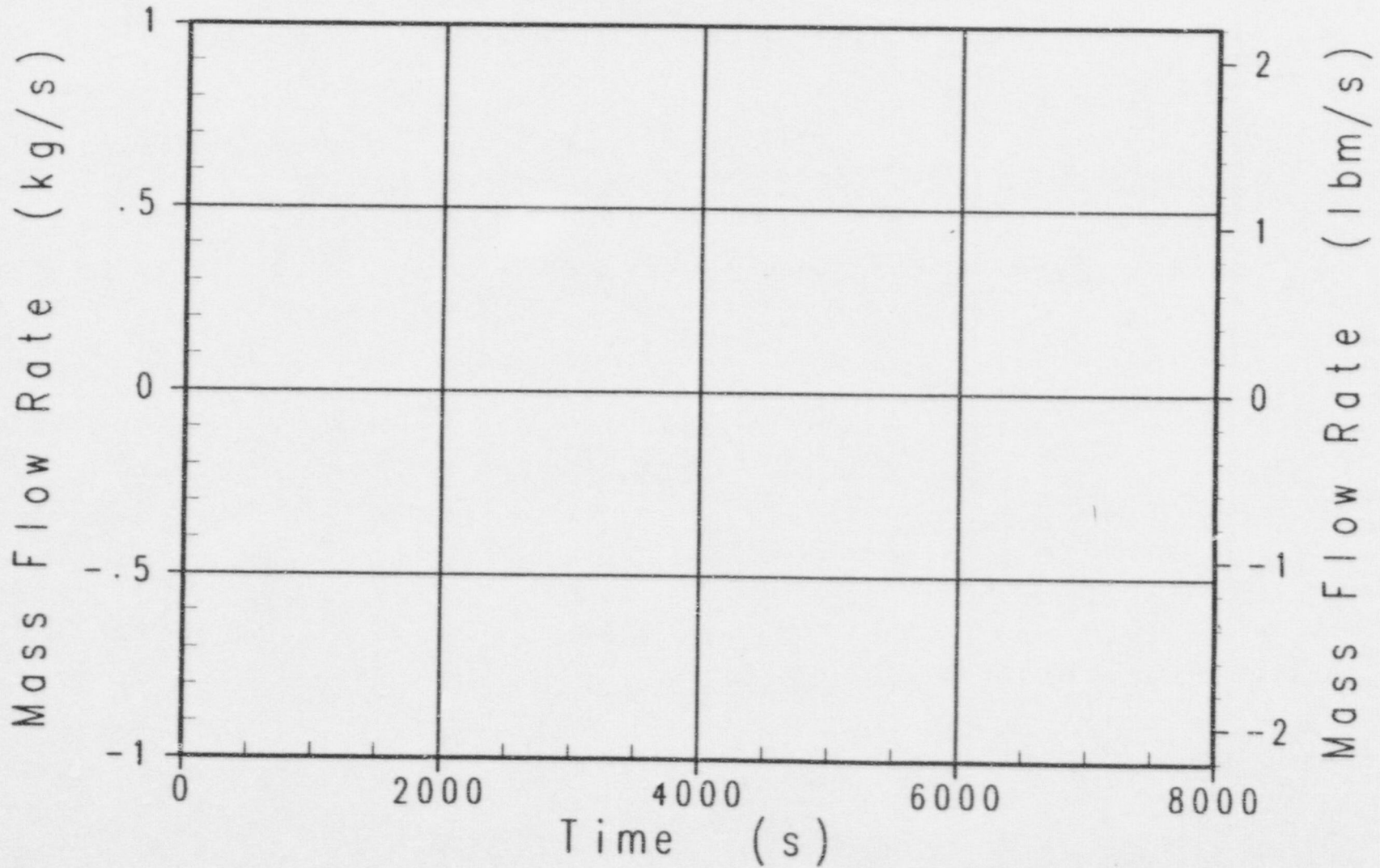

Case m6a AP600 Success Criteria MAAP4 Analysis
Safety Valve and ADS Stages 1-3 Liquid Flowrate

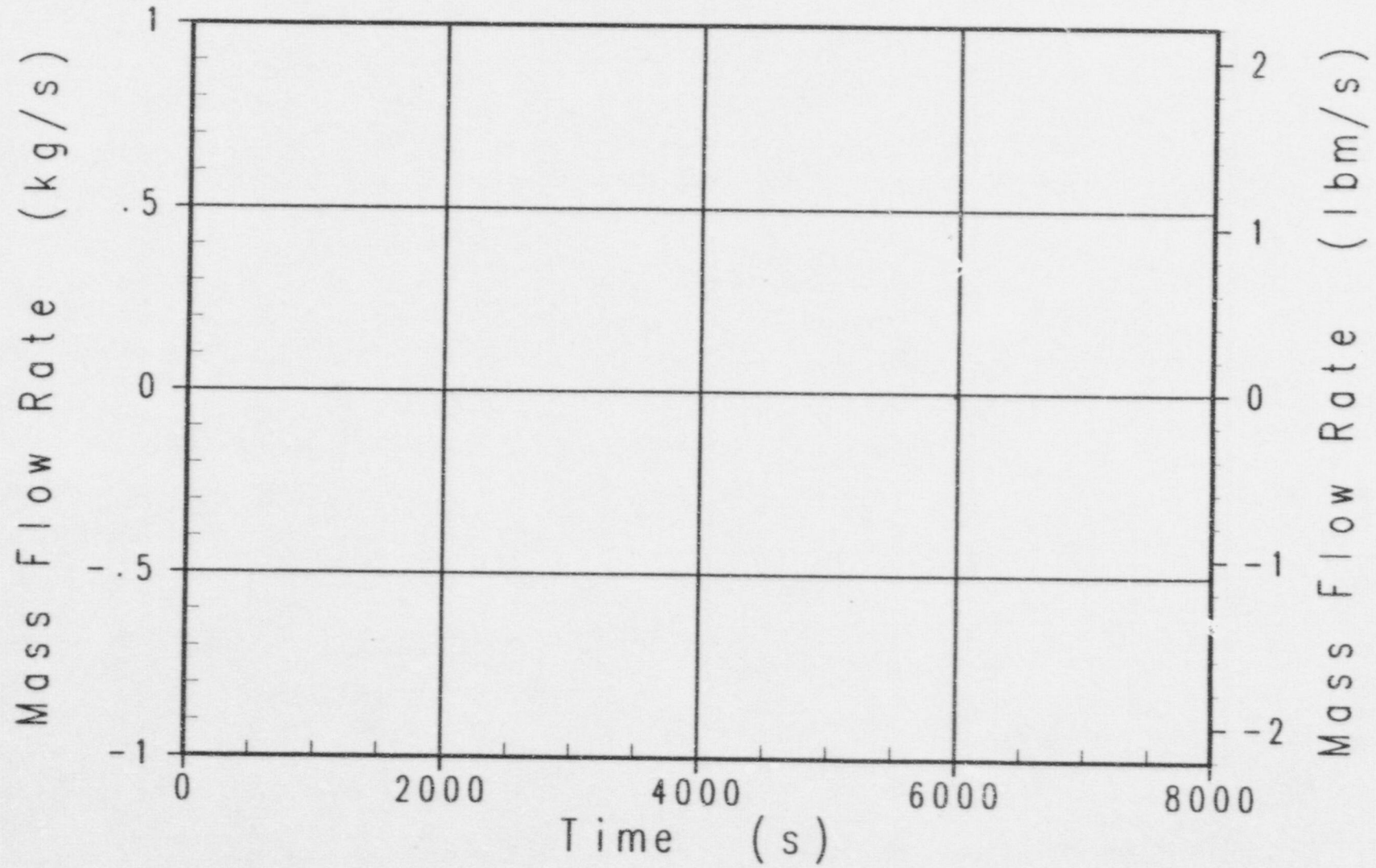

Case m6a AP600 Success Criteria MAAP4 Analysis
CMT-1 Water Level

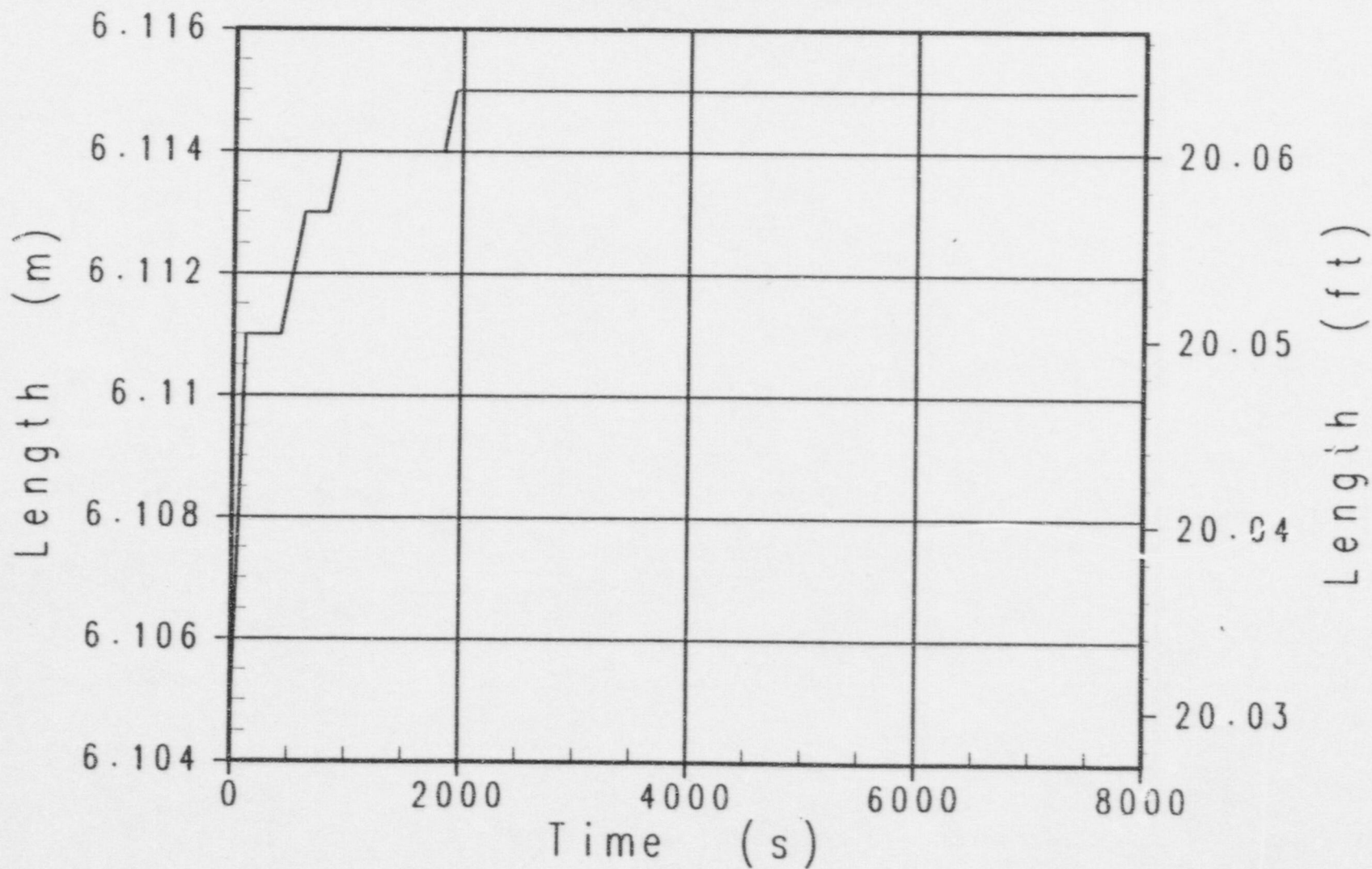

Case m6a AP600 Success Criteria MAAP4 Analysis
Pressurizer Water Level (From Pzr Bottom)

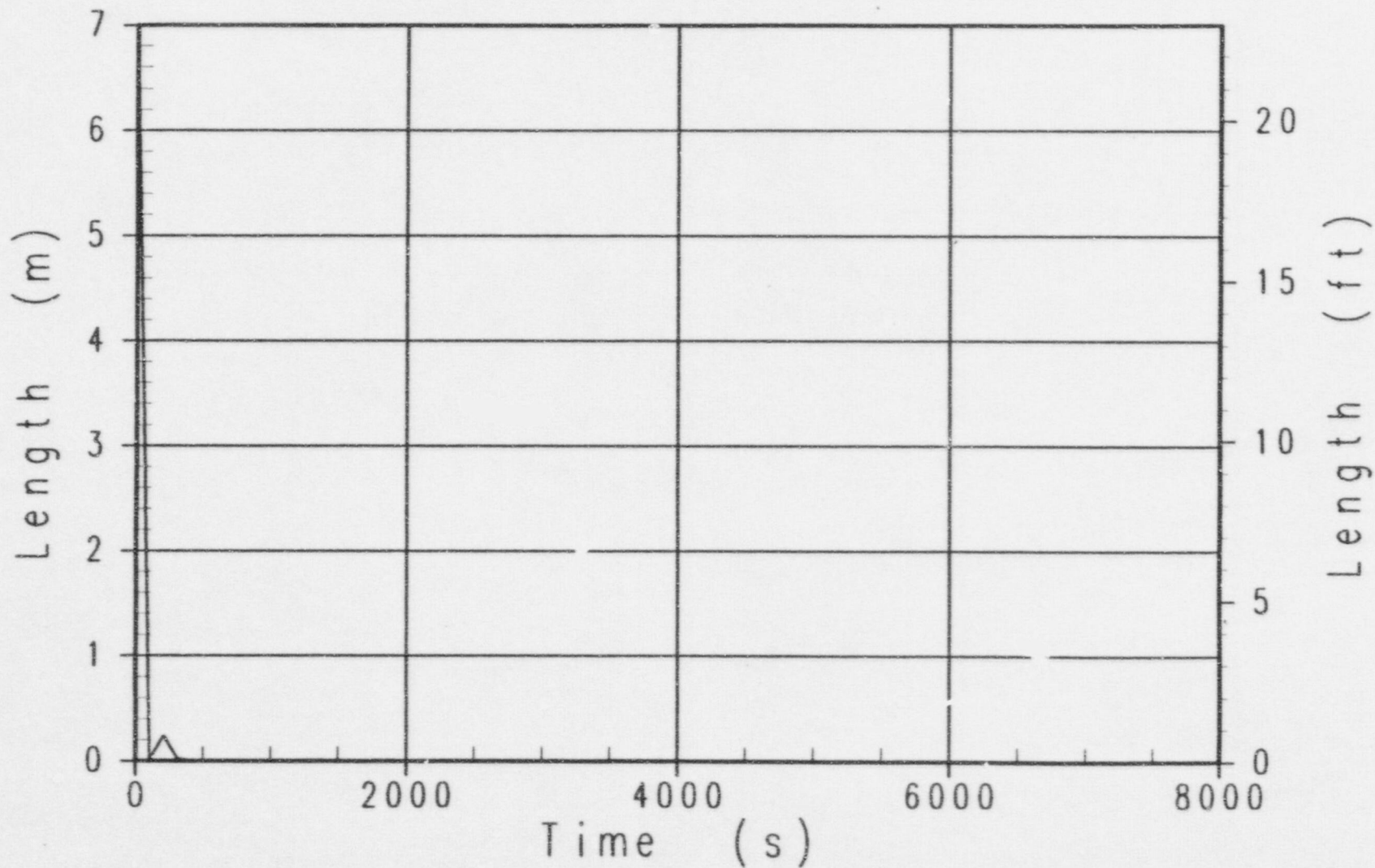

Case x3j5 AP600 Success Criteria MAA4 Analysis
Broken Loop Steam Generator Pressure

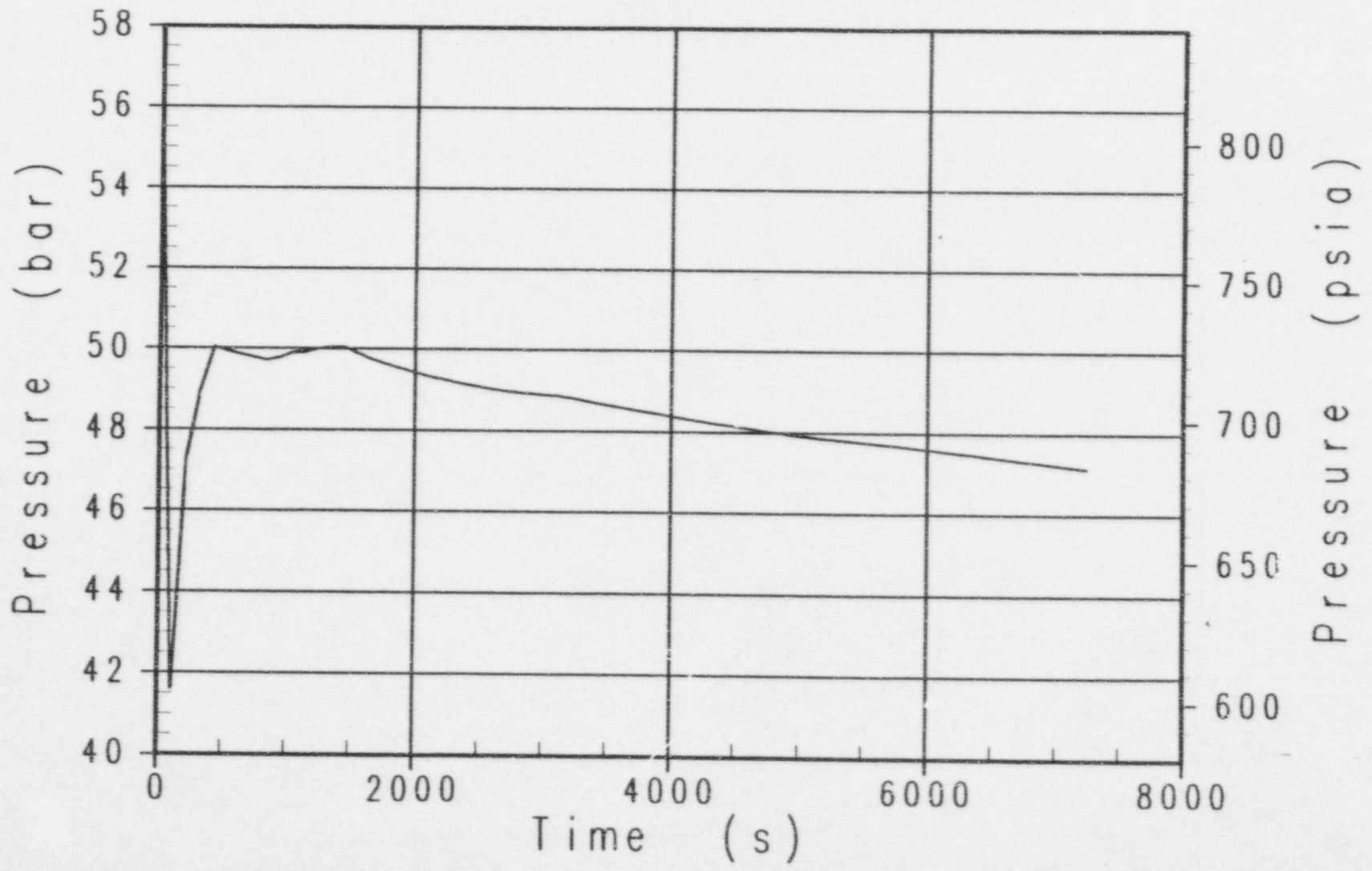

Case x3j5 AP600 Success Criteria MAAP4 Analysis
Primary System Pressure

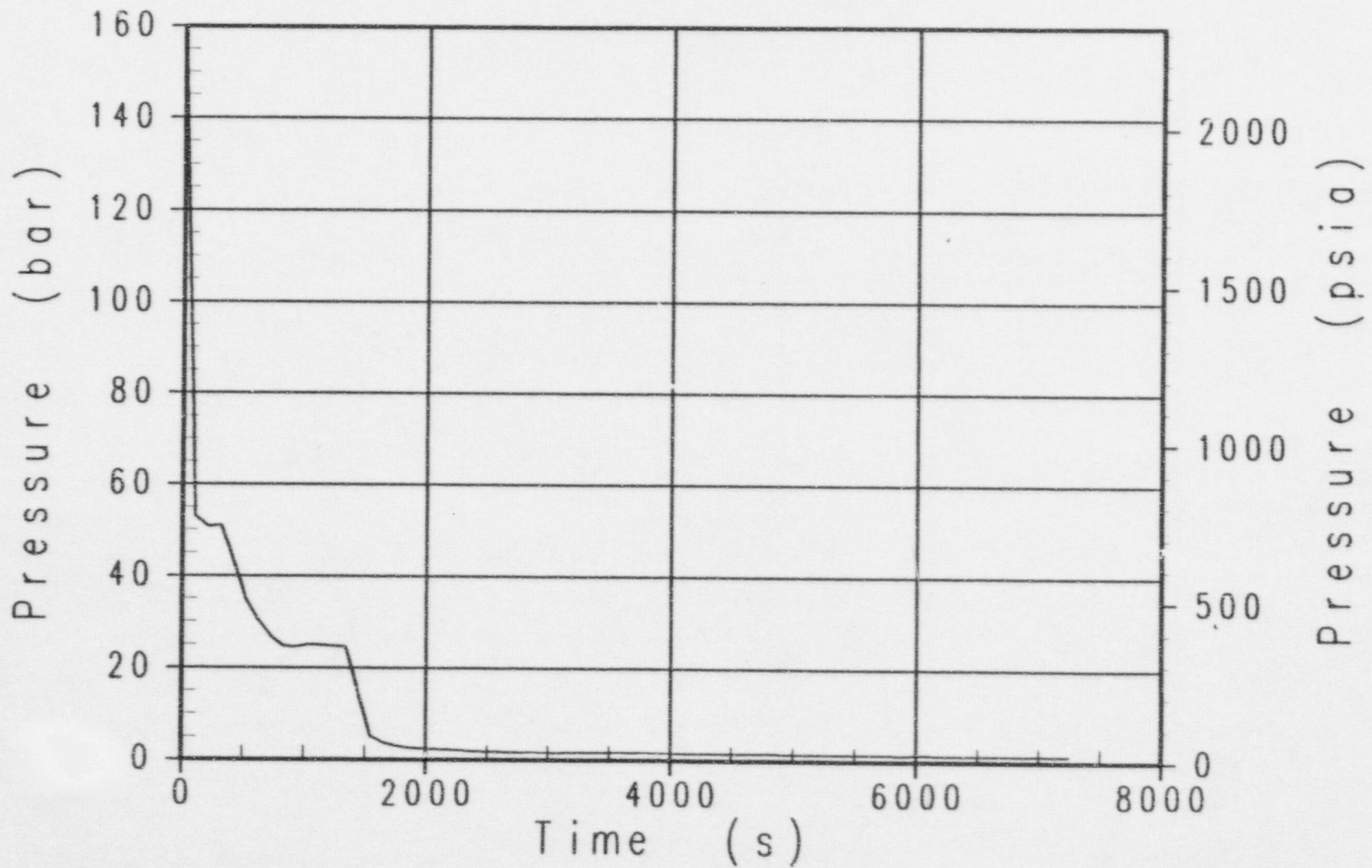

Case x3j5 AP600 Success Criteria MAAP4 Analysis
Containment Pressure

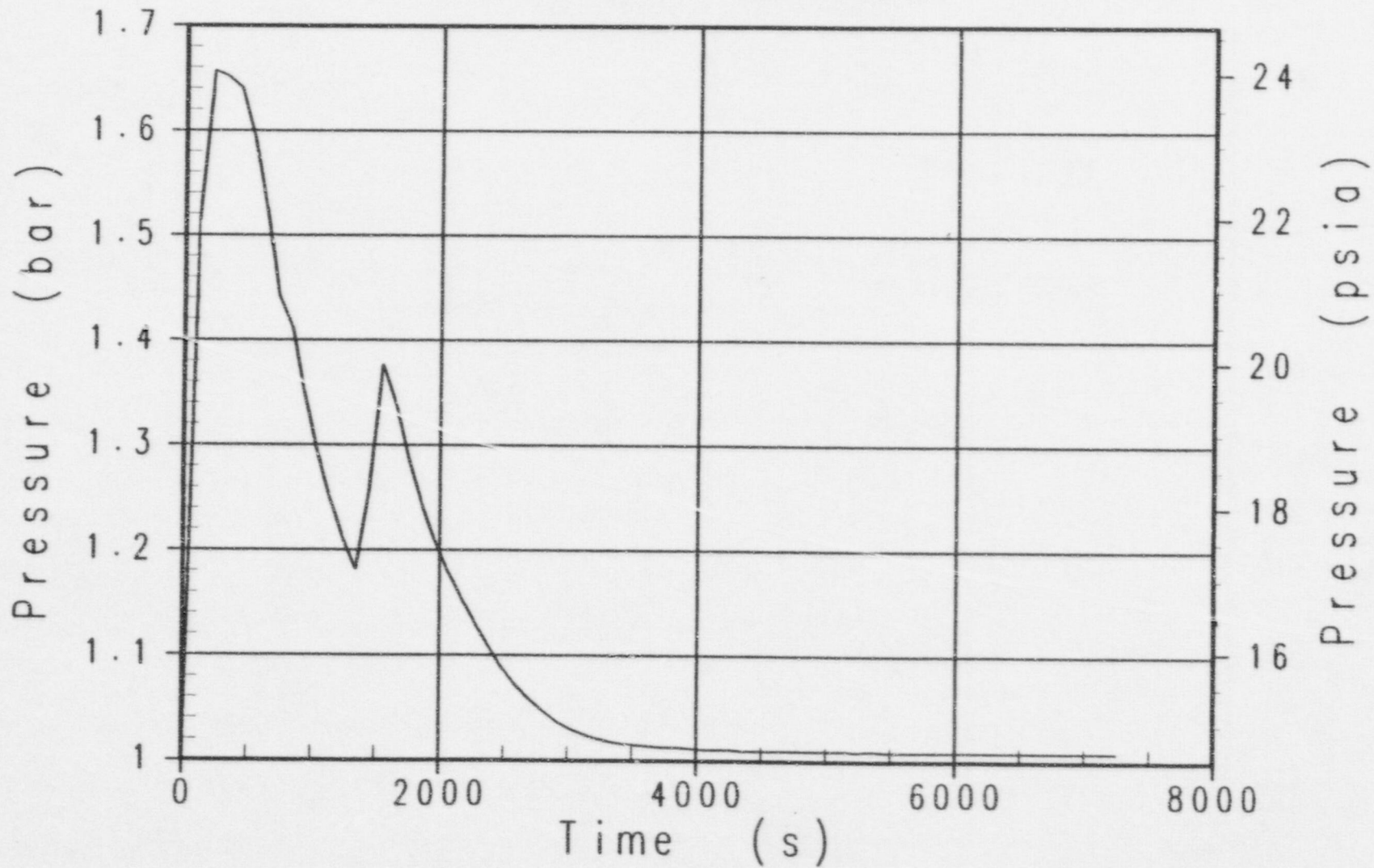

Case x3j5 AP600 Success Criteria MAAP4 Analysis
Unbroken Loop Steam Generator Pressure

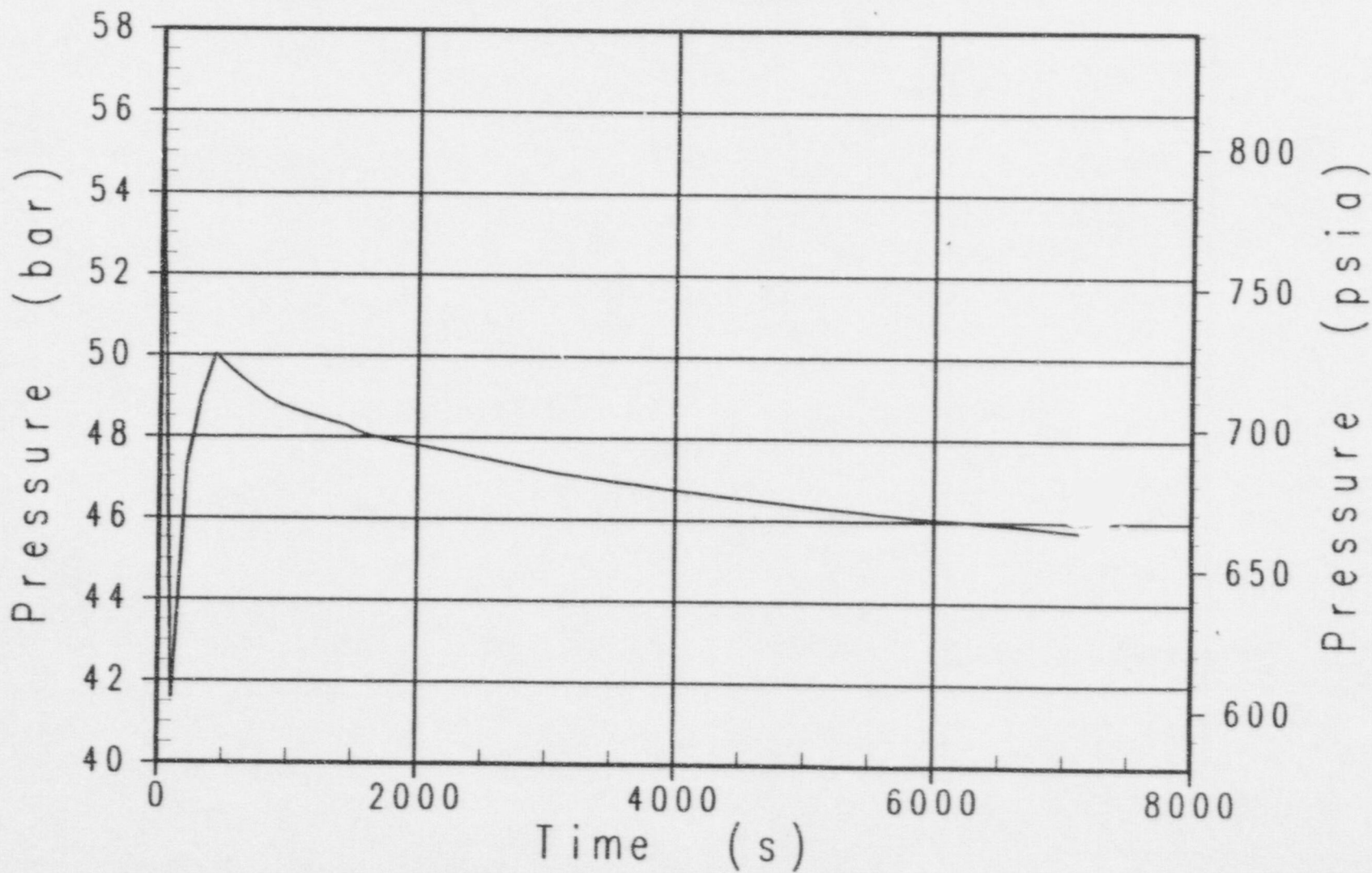

Case x3j5 AP600 Success Criteria MAAP4 Analysis
Decay Power

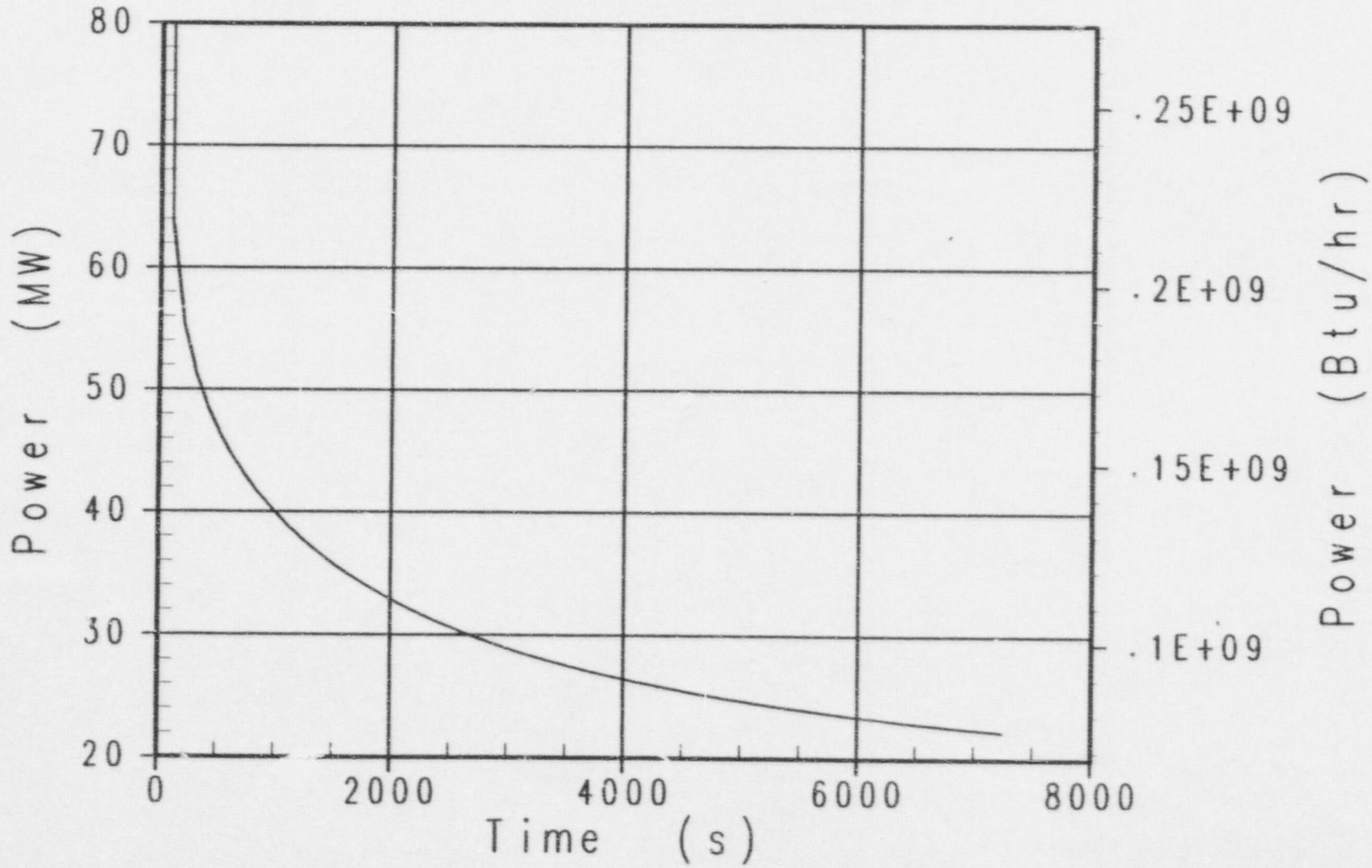

Case x3j5 AP600 Success Criteria MAAP4 Analysis
PRHR Heat Removal Rate

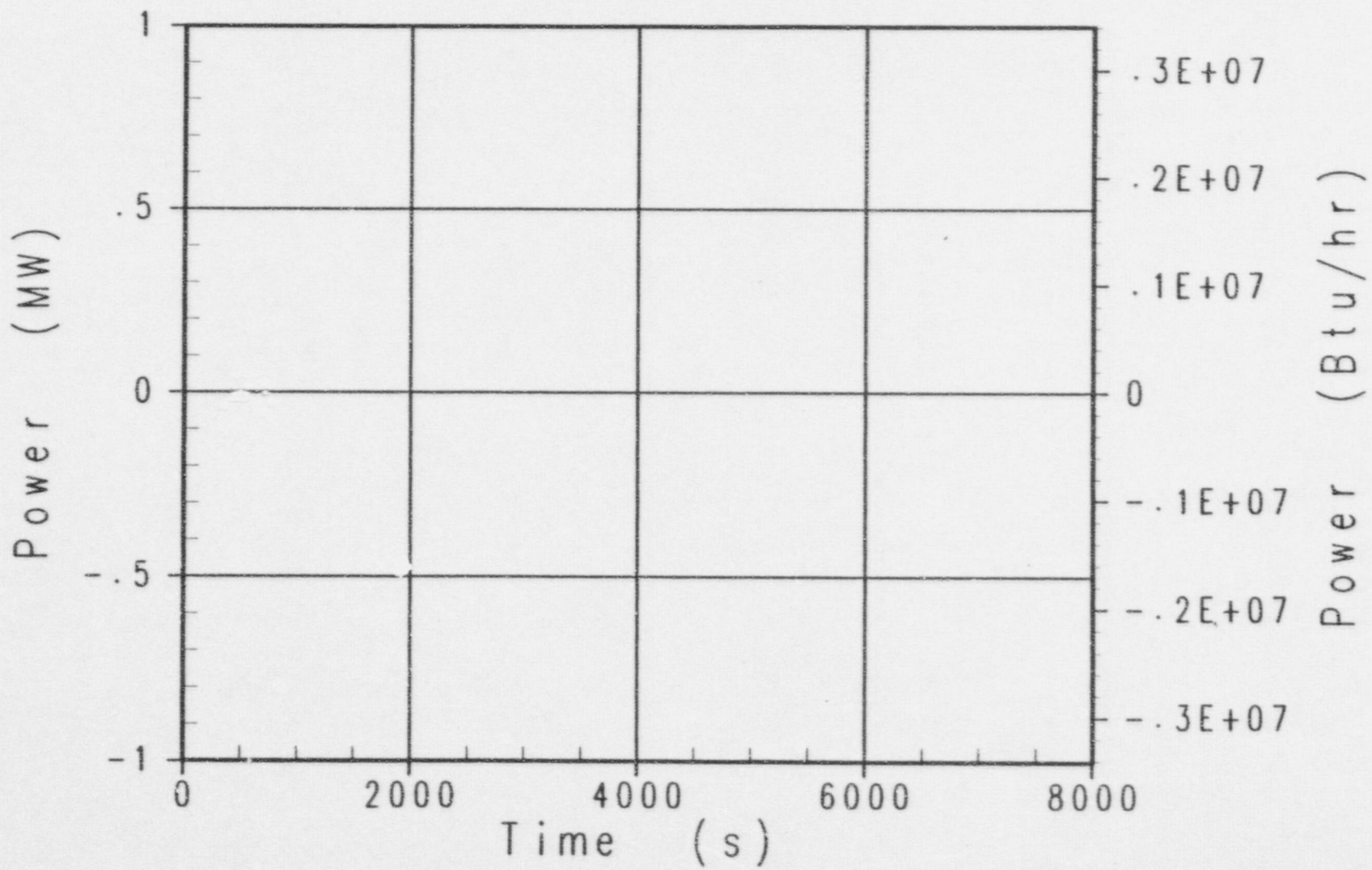

Case x3j5 AP600 Success Criteria MAMP4 Analysis
Peak Temperature in the Core

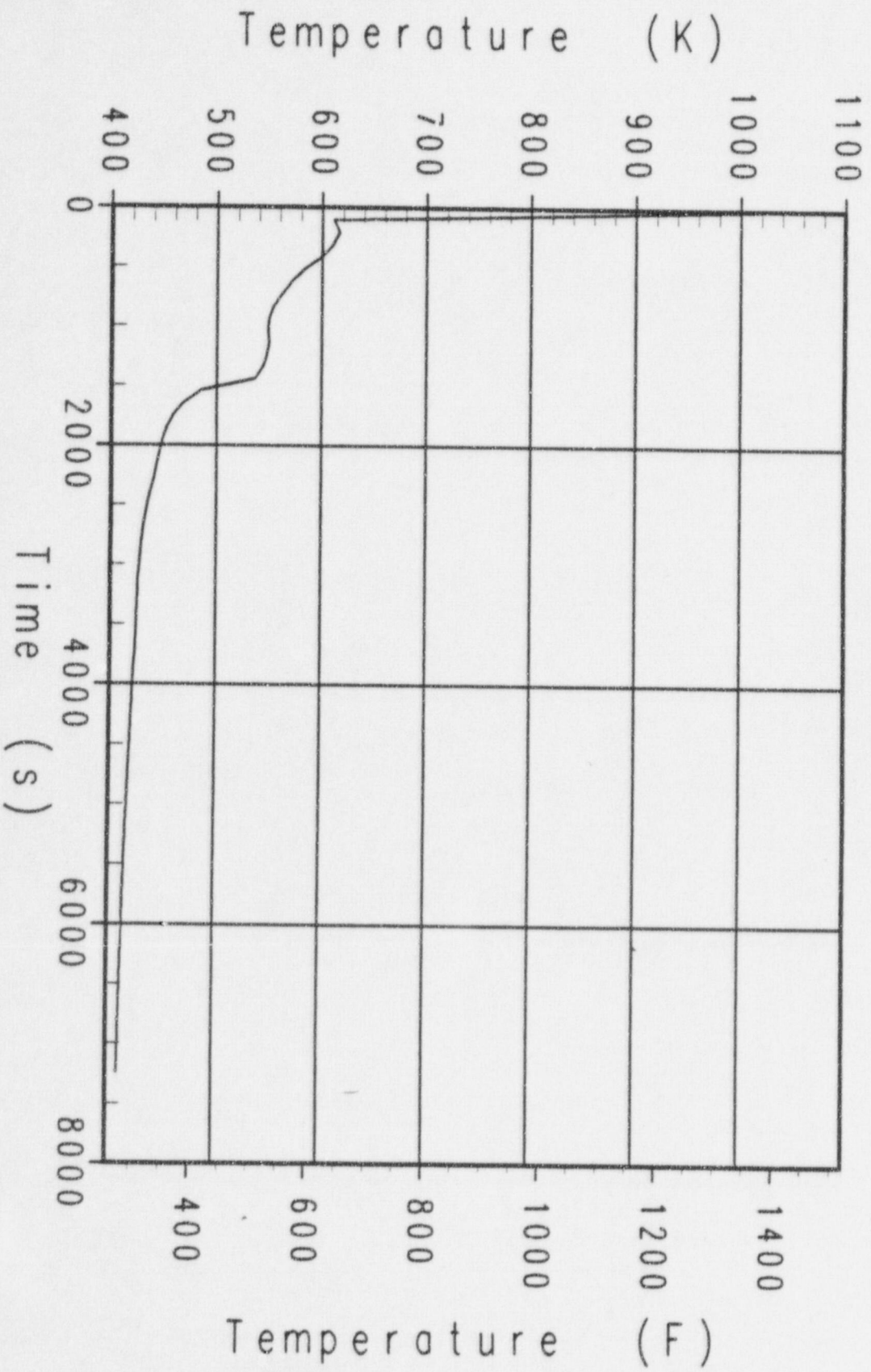

Case x3j5 AP600 Success Criteria MAAP4 Analysis
Cold Leg Water Temperature

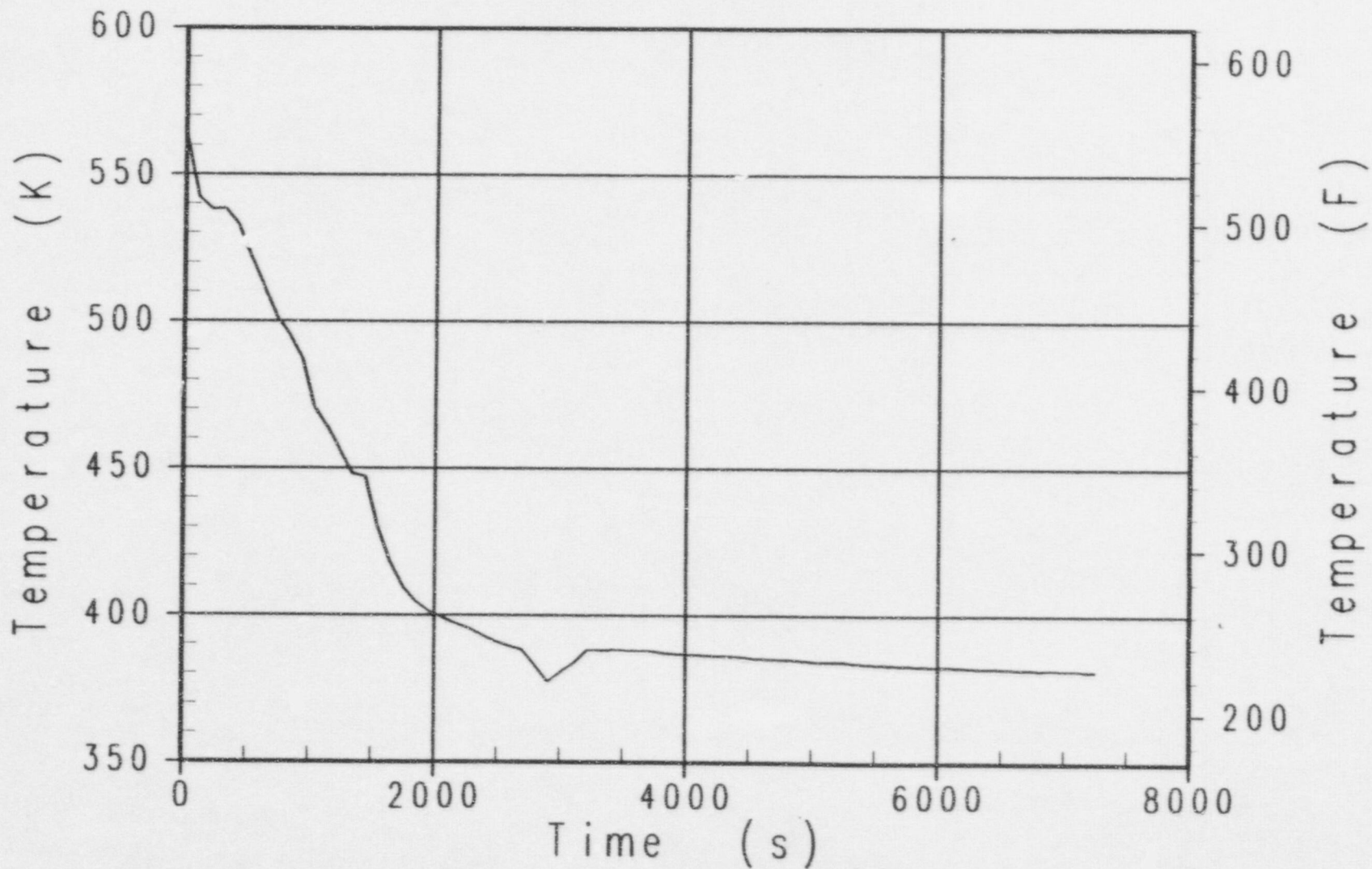

Case x3j5 AP600 Success Criteria MAAP4 Analysis
Core Water Temperature

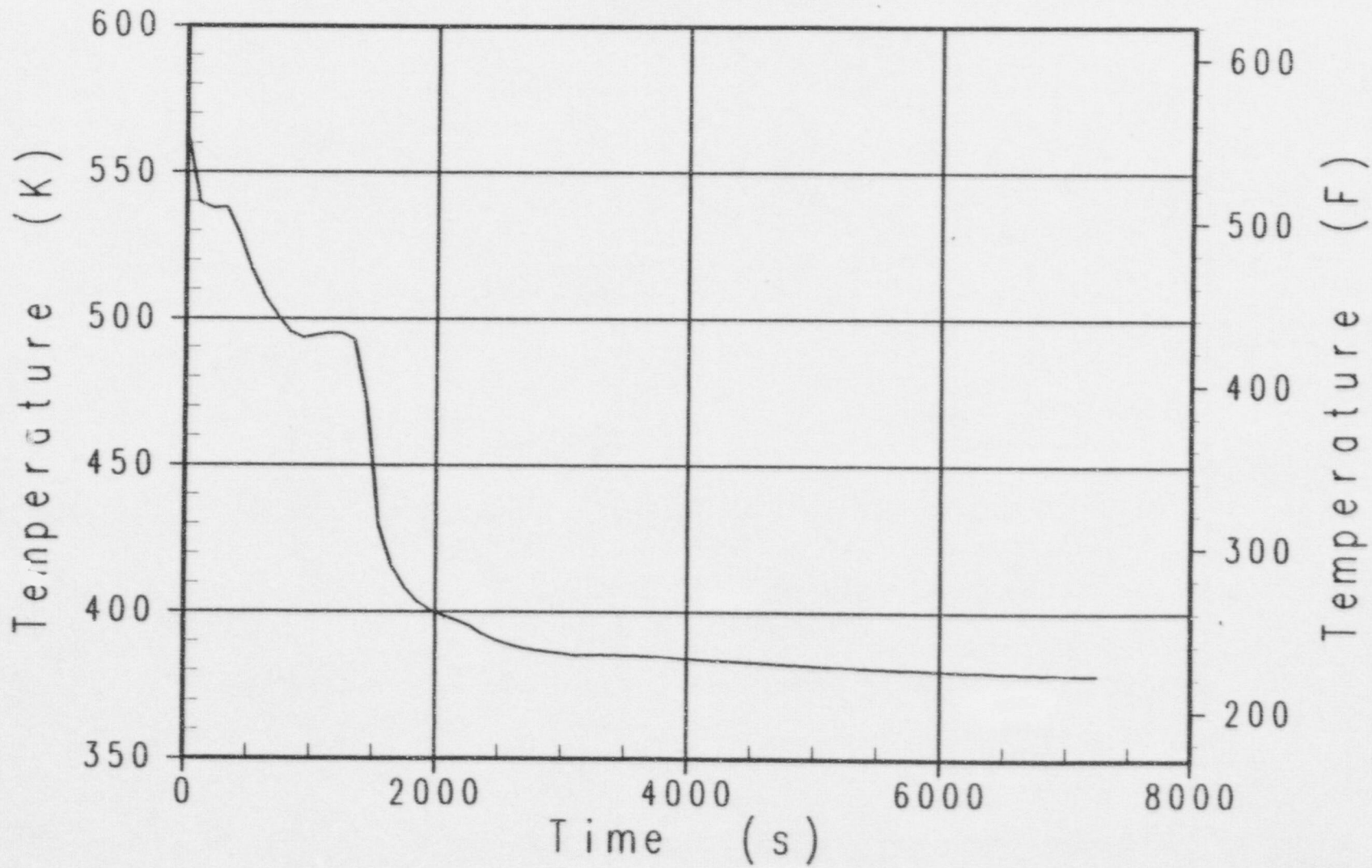

Case x3j5 AP600 Success Criteria MAAP4 Analysis
RPV Downcomer Water Temperature

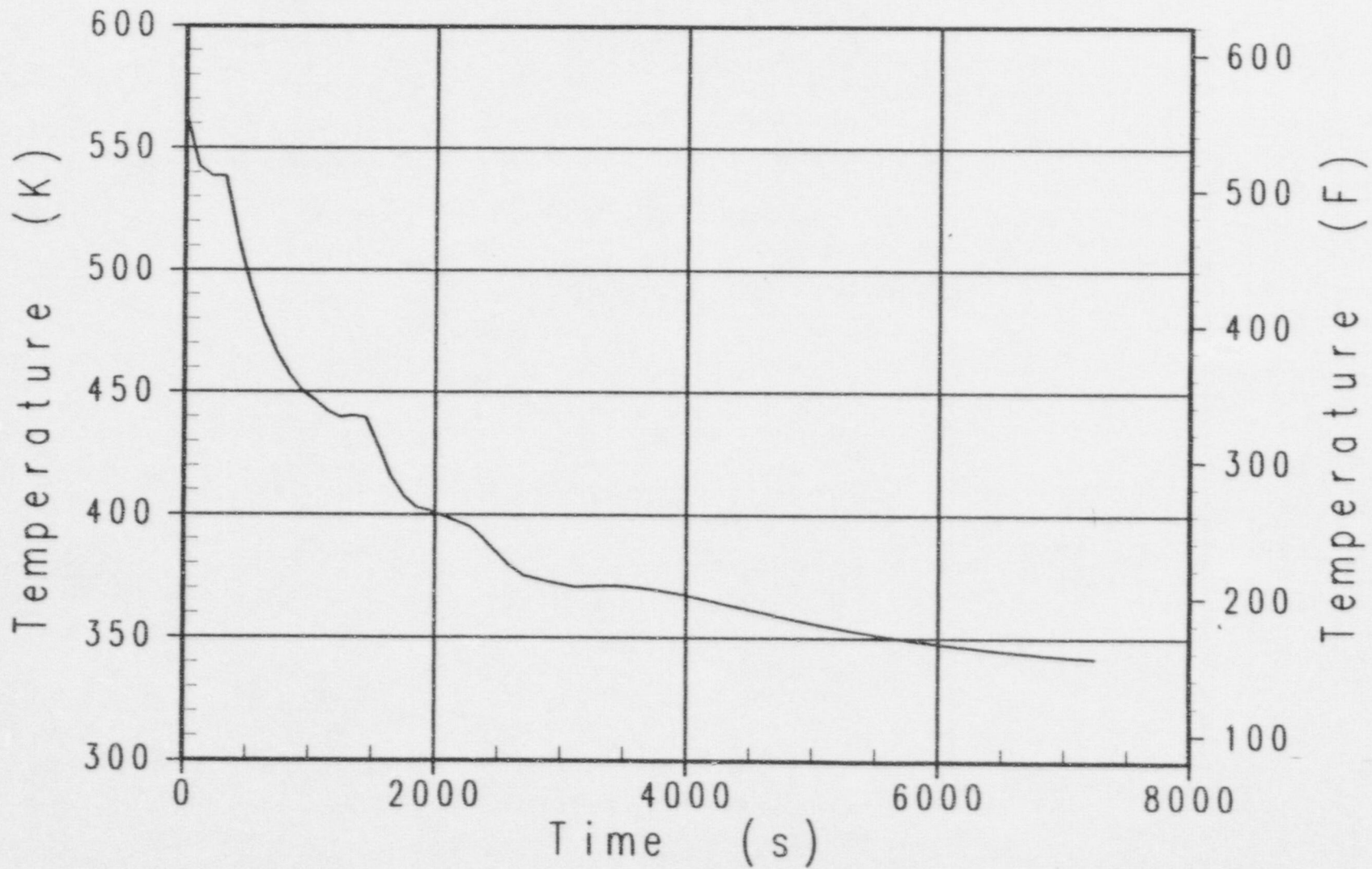

Case x3j5 AP600 Success Criteria MAAP4 Analysis
IRWST Water Temperature

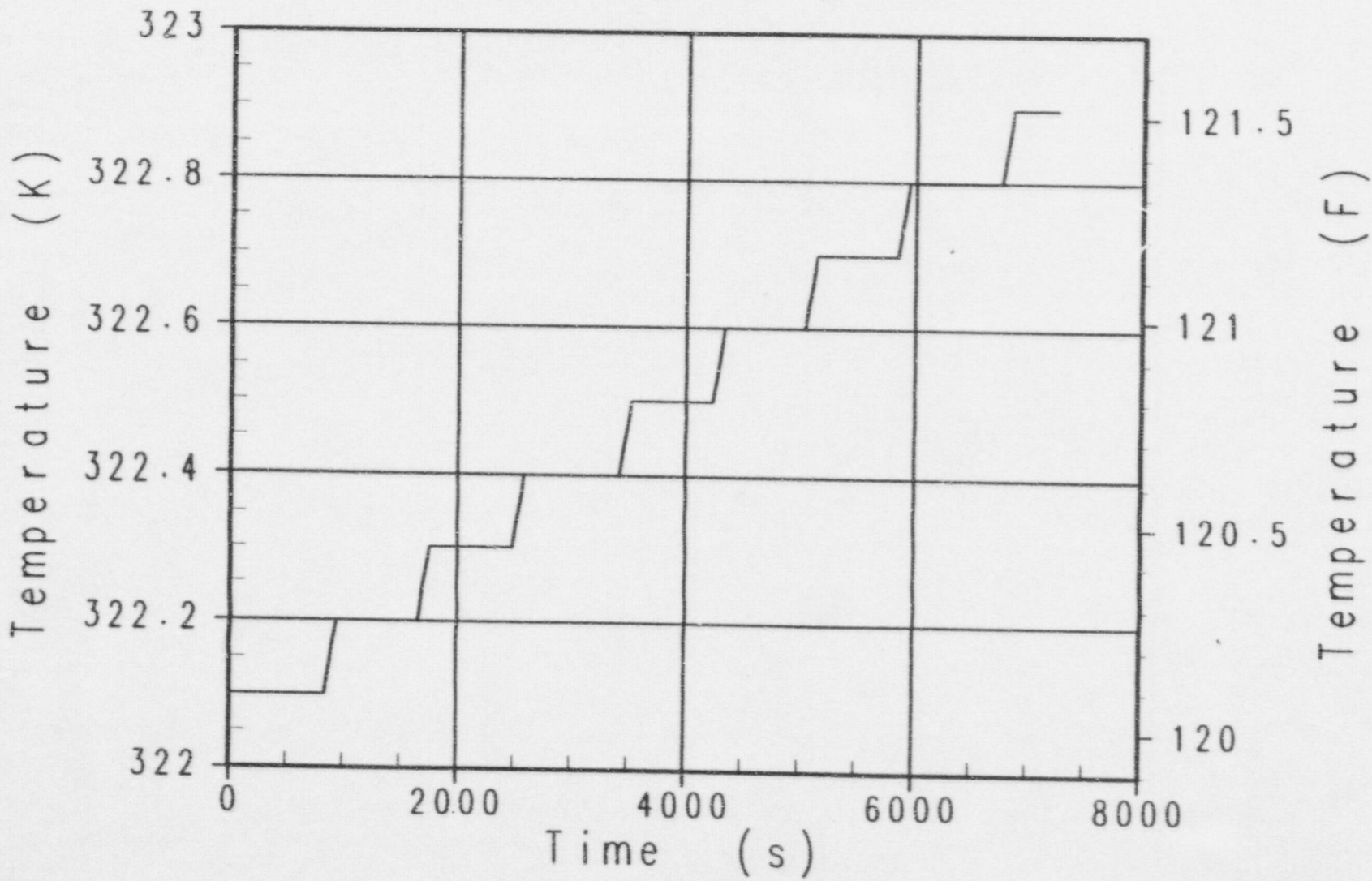

Case x3j5 AP600 Success Criteria MAAP4 Analysis
Accumulator and NRHR Injection Flowrate

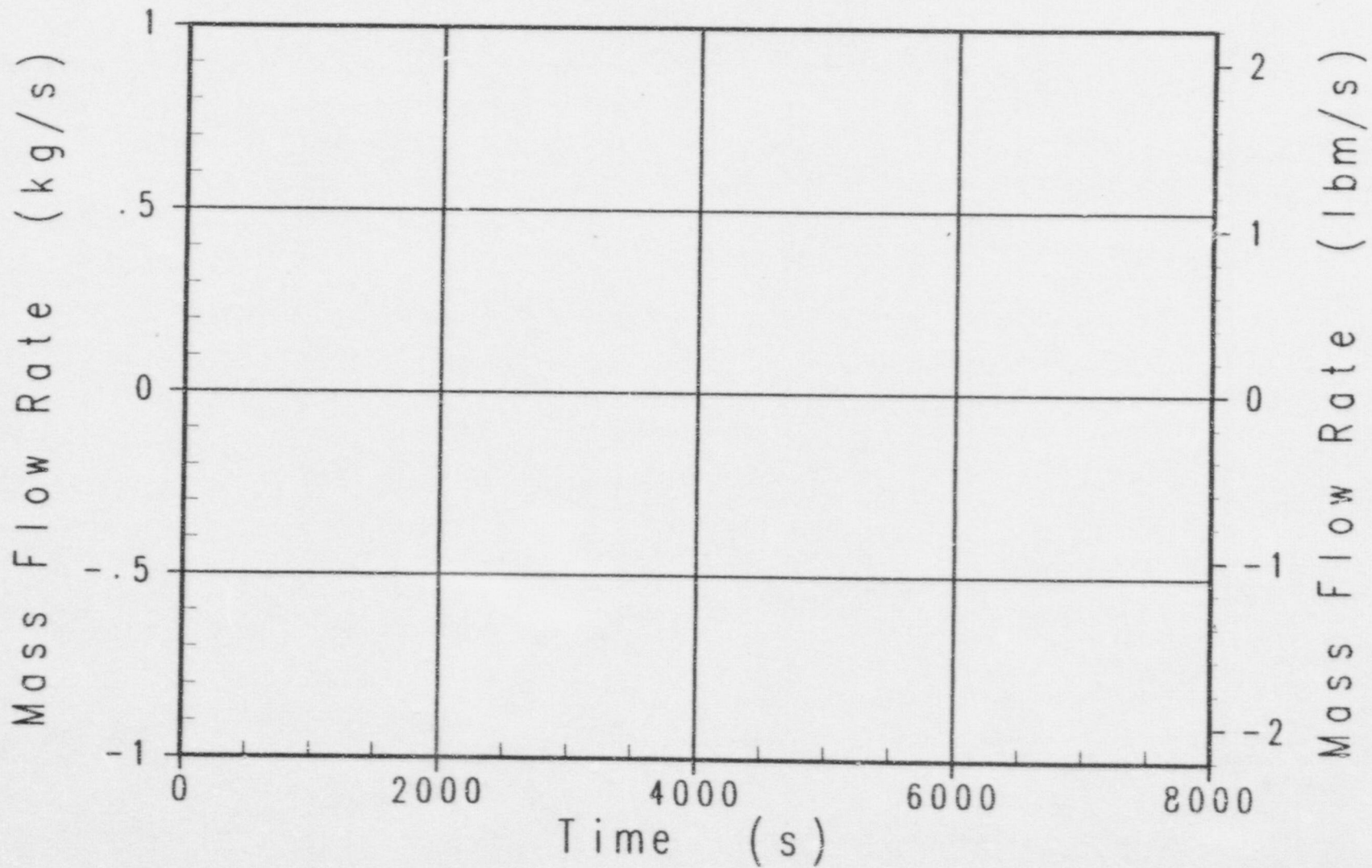

Case x3j5 AP600 Success Criteria MAAP4 Analysis
RCS Break Gas Flowrate

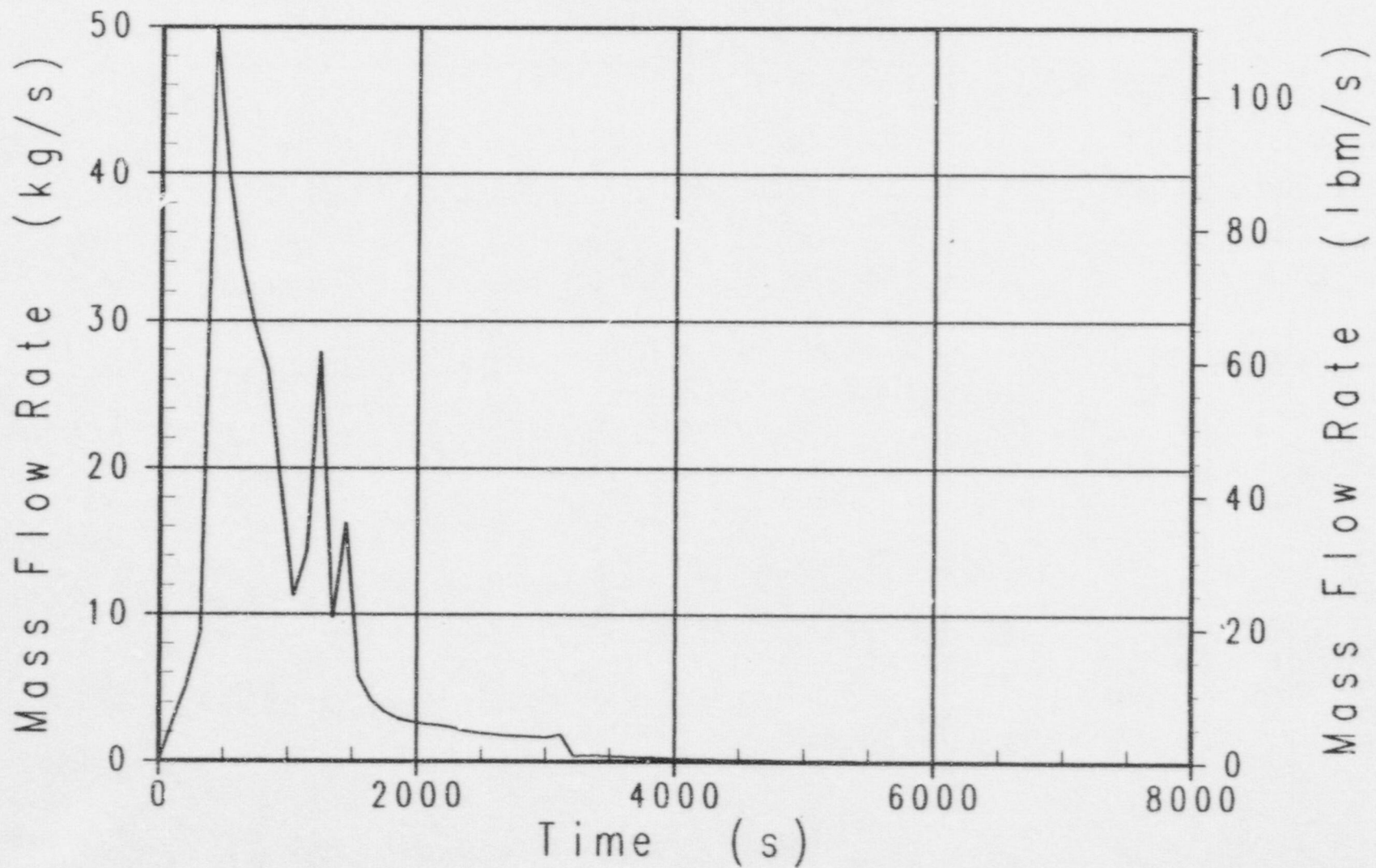

Case x3j5 AP600 Success Criteria MAAP4 Analysis
ADS Stage 4 Gas Flowrate

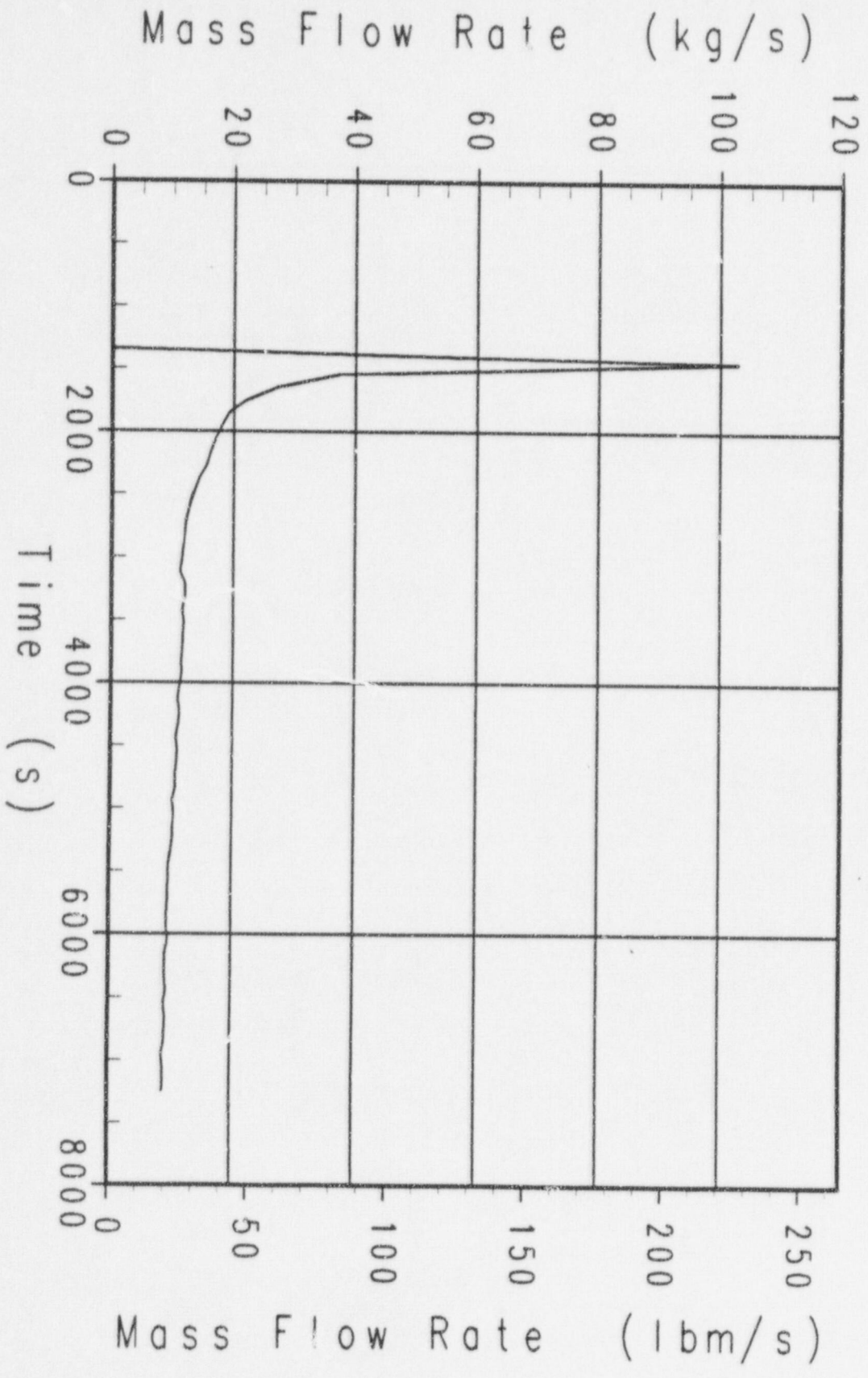

Case x3j5 AP600 Success Criteria MAAP4 Analysis
Safety Valve and ADS Stages 1-3 Gas Flowrate

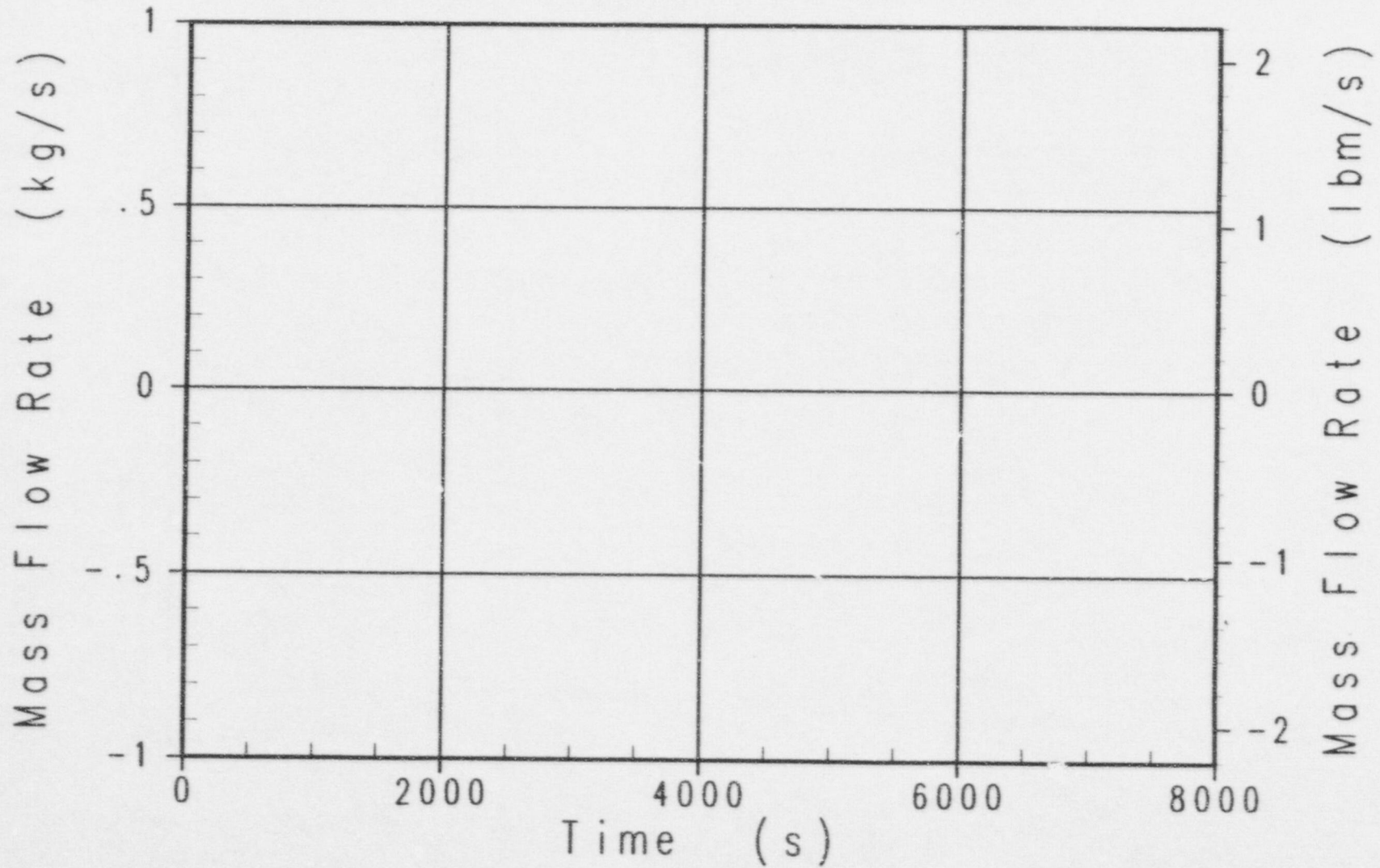

Case x3j5 AP600 Success Criteria MAAp4 Analysis
RCS Break Liquid Flowrate

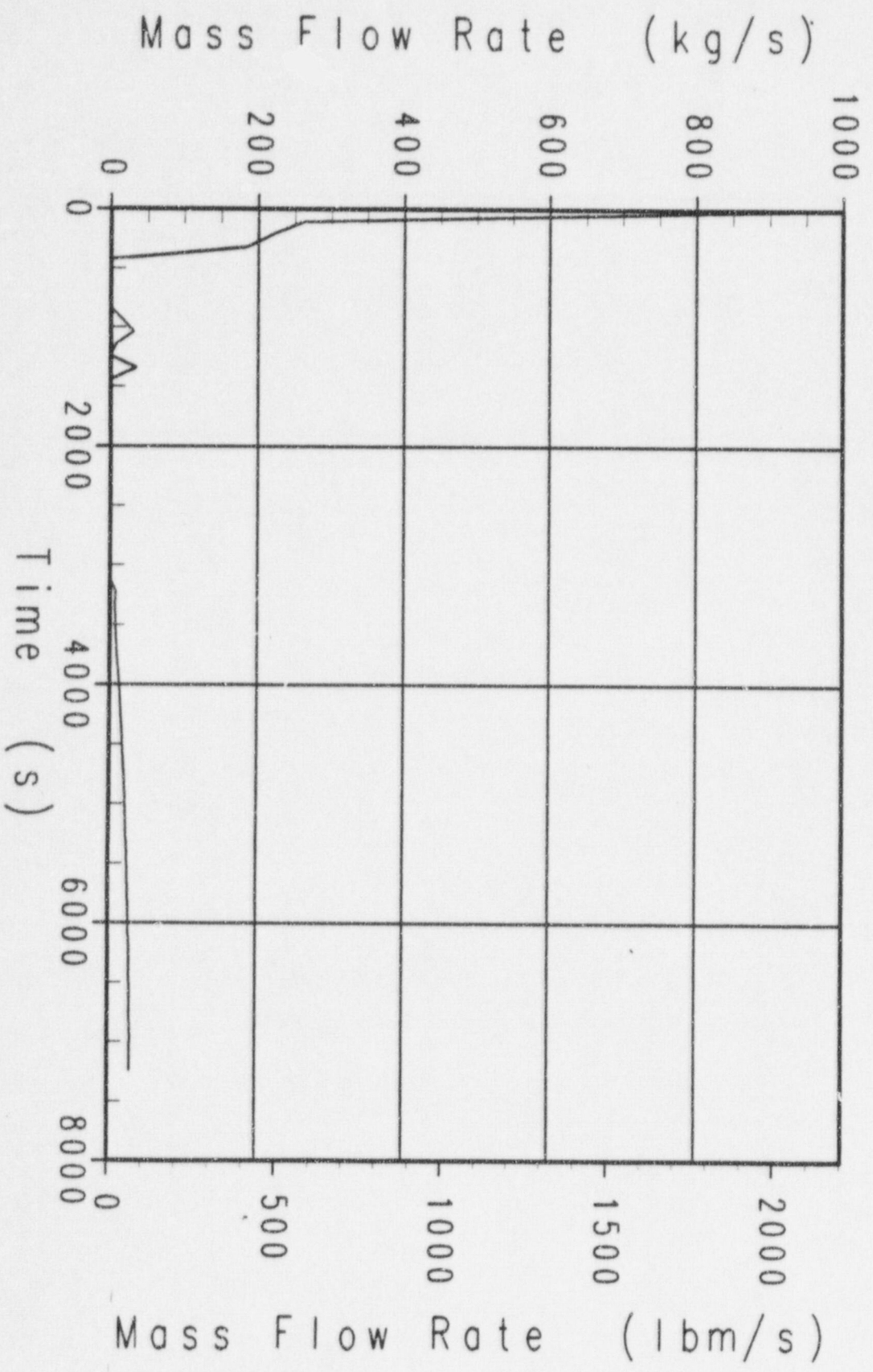

Case x3j5 AP600 Success Criteria MAAP4 Analysis
ADS Stage 4 Liquid Flowrate

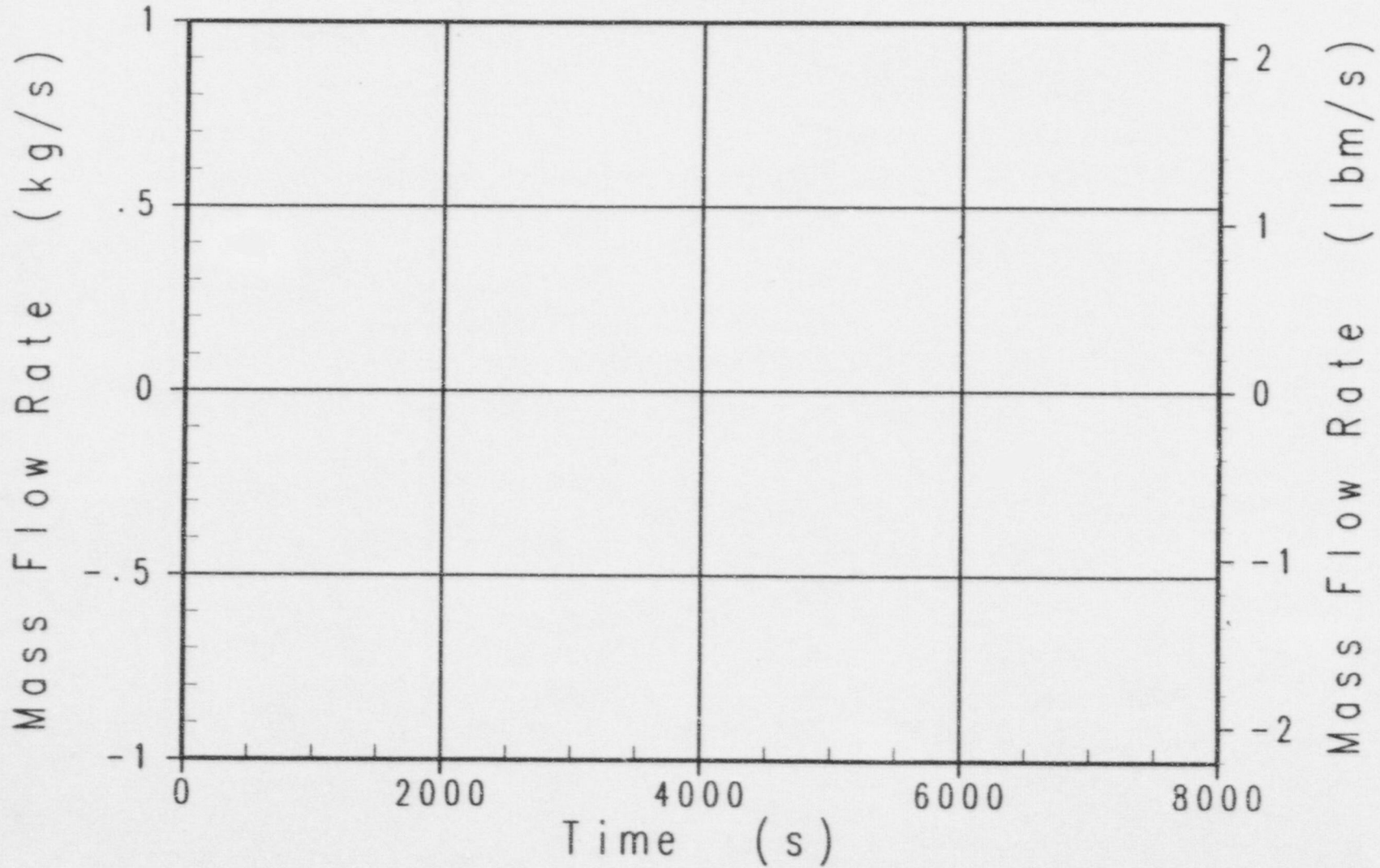

Case x3j5 AP600 Success Criteria MAAP4 Analysis
IRWST Injection Flowrate (neg. means into RCS)

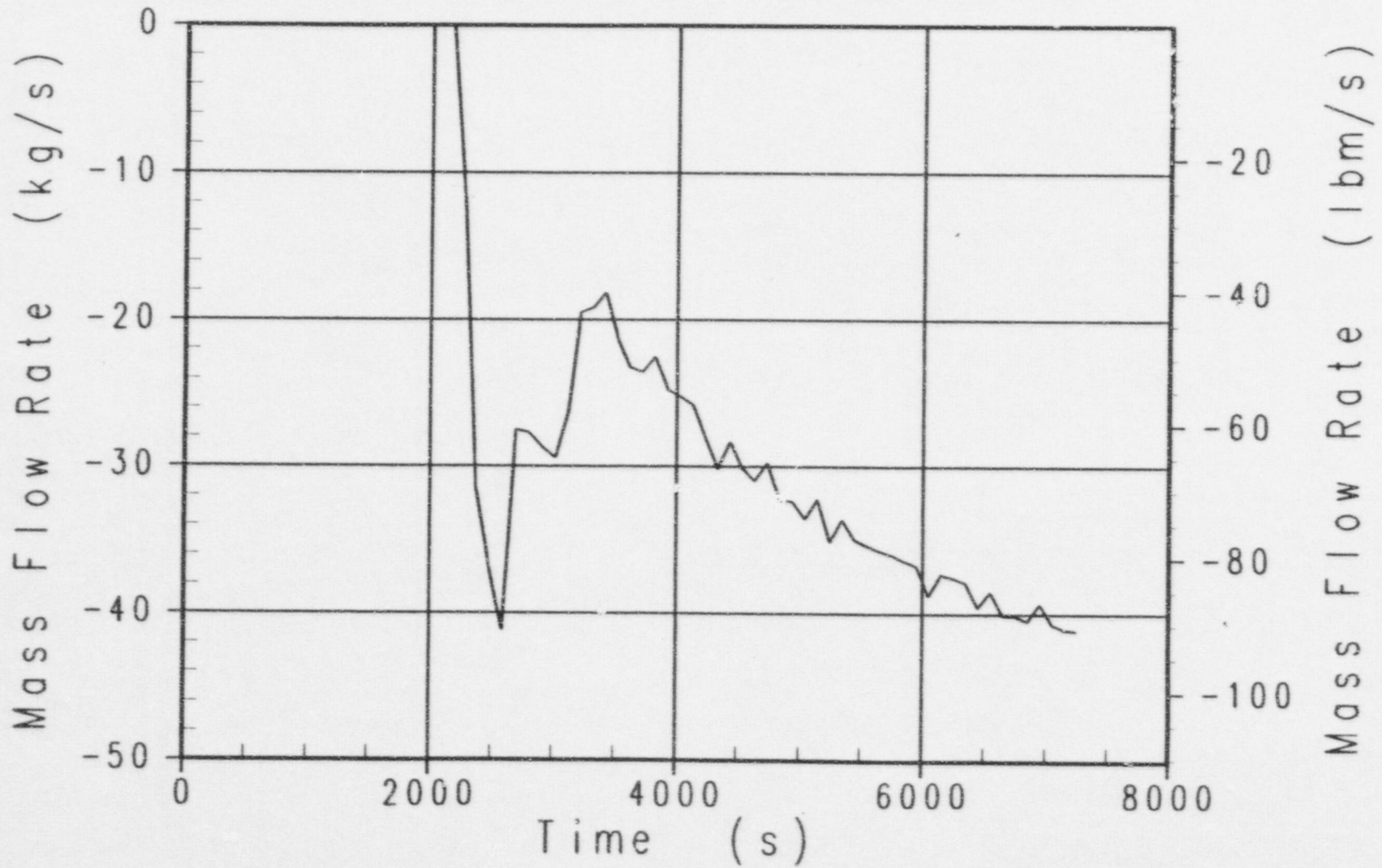

Case x3j5 AP600 Success Criteria MAAP4 Analysis
CMT-1 Injection Flowrate

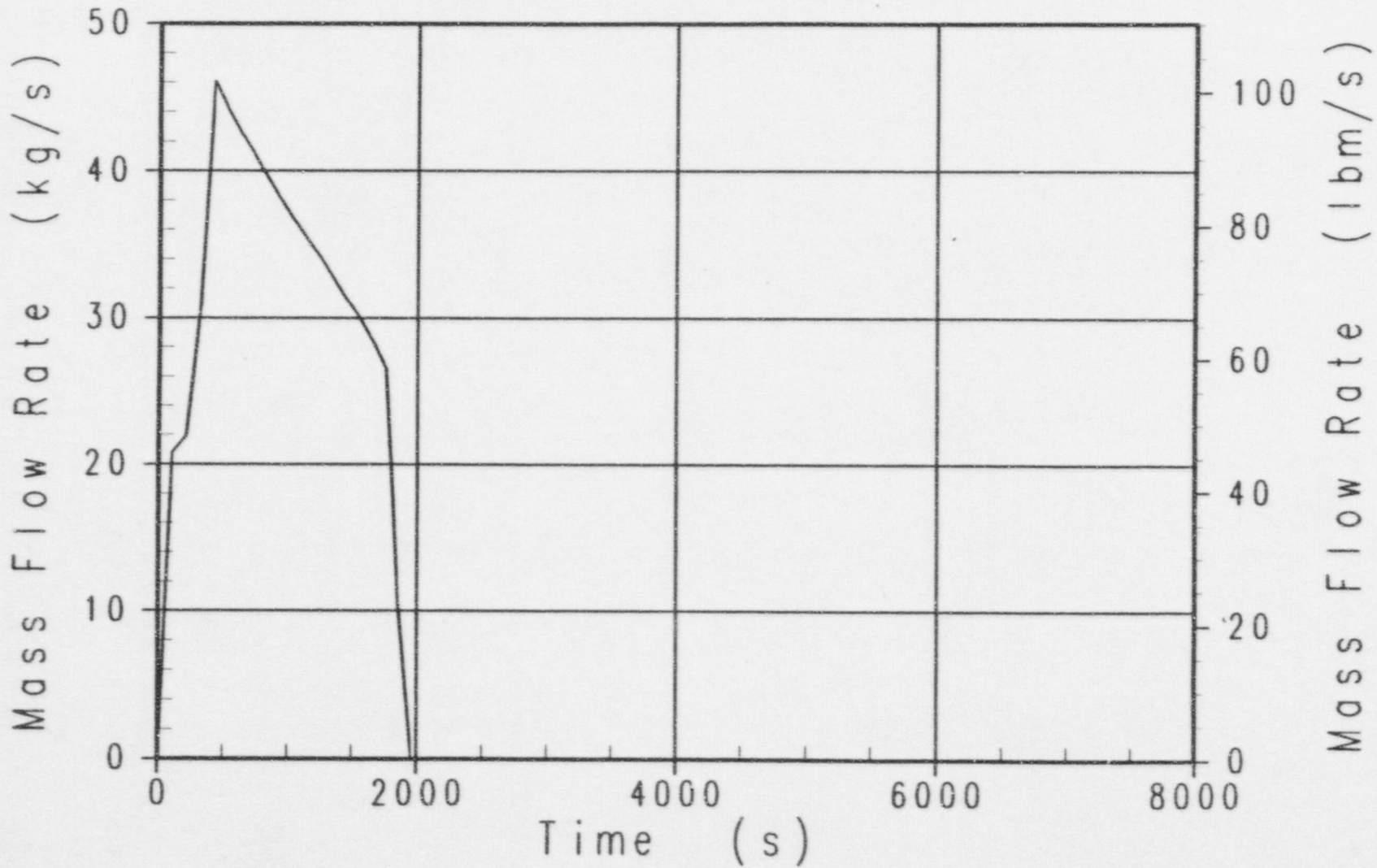

Case x3j5 AP600 Success Criteria MAAP4 Analysis
Safety Valve and ADS Stages 1-3 Liquid Flowrate

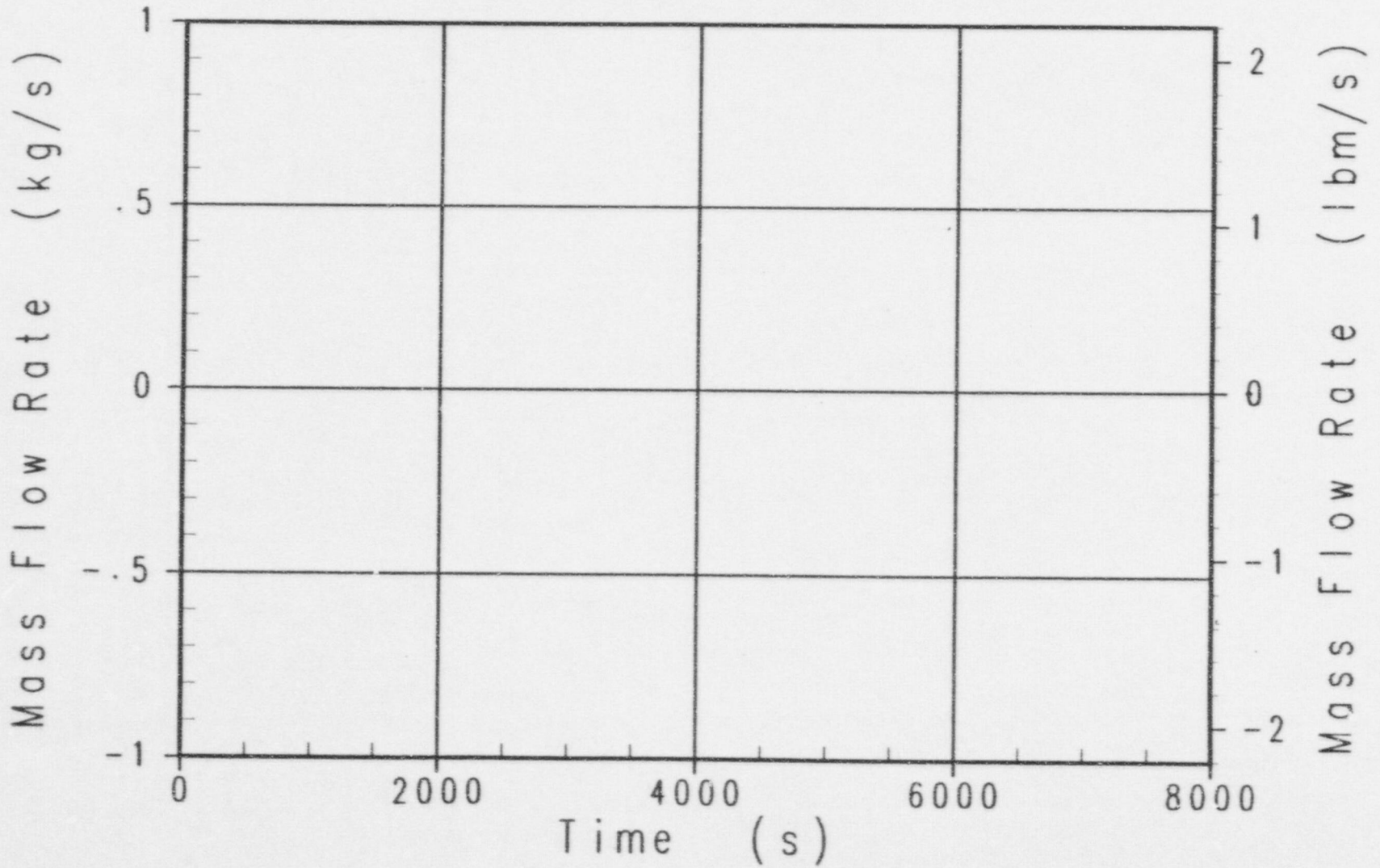

Case x3j5 AP600 Success Criteria MAAP4 Analysis
CMT-1 Water Level

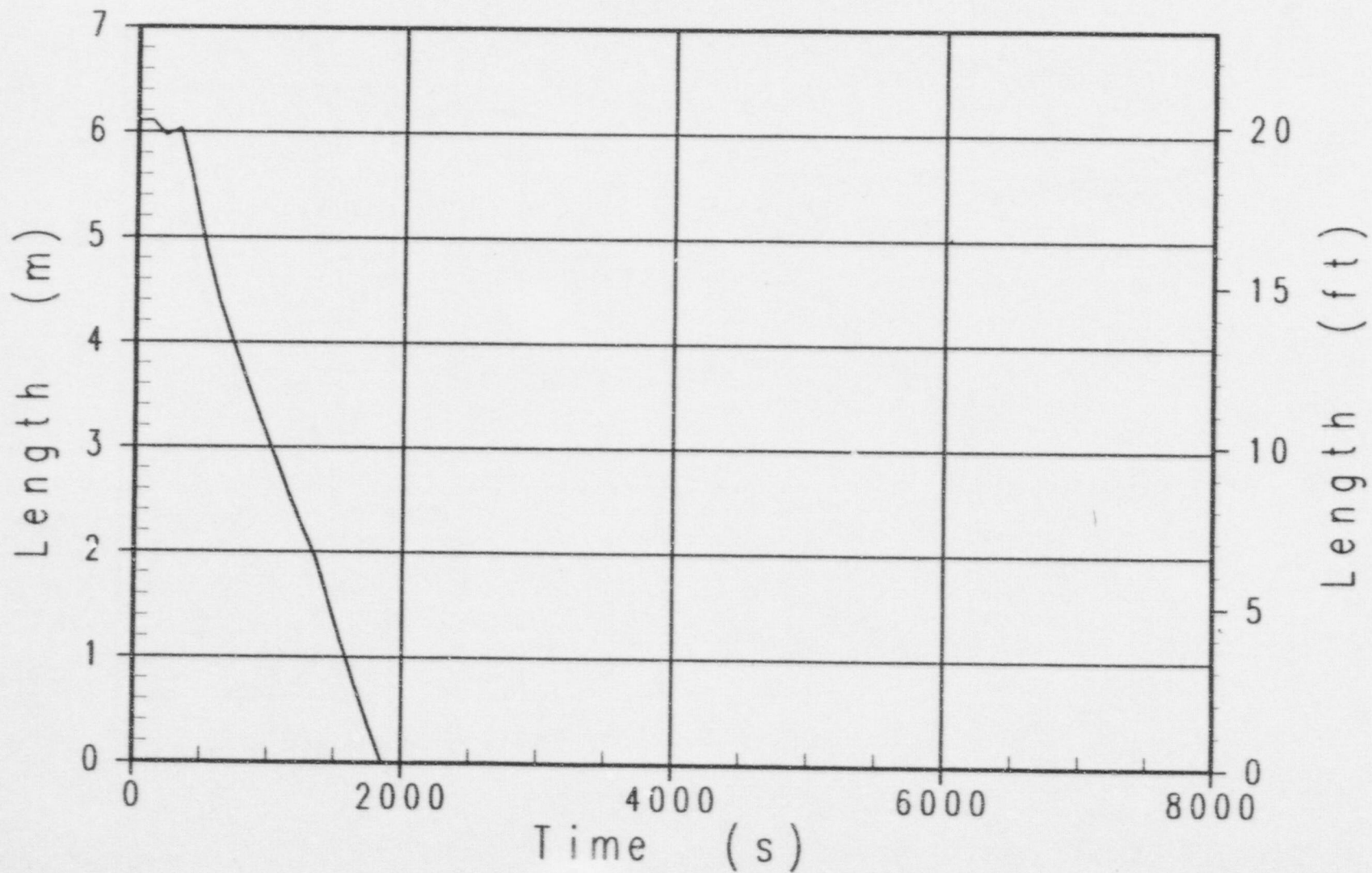

Case x3j5 AP600 Success Criteria MAAP4 Analysis
Pressurizer Water Level (From Pzr Bottom)

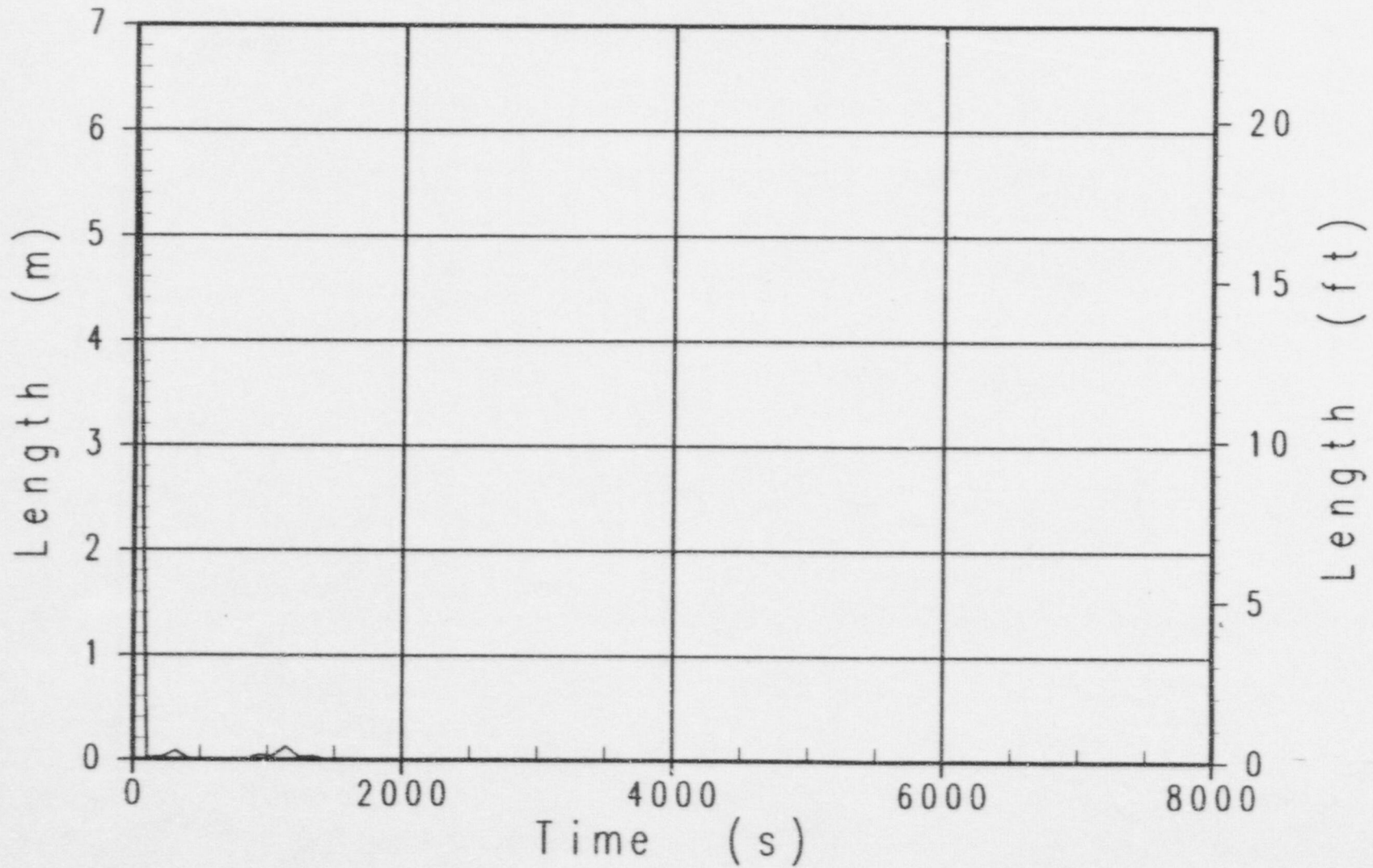

Case x4d2 AP600 Success Criteria MAAP4 Analysis
Broken Loop Steam Generator Pressure

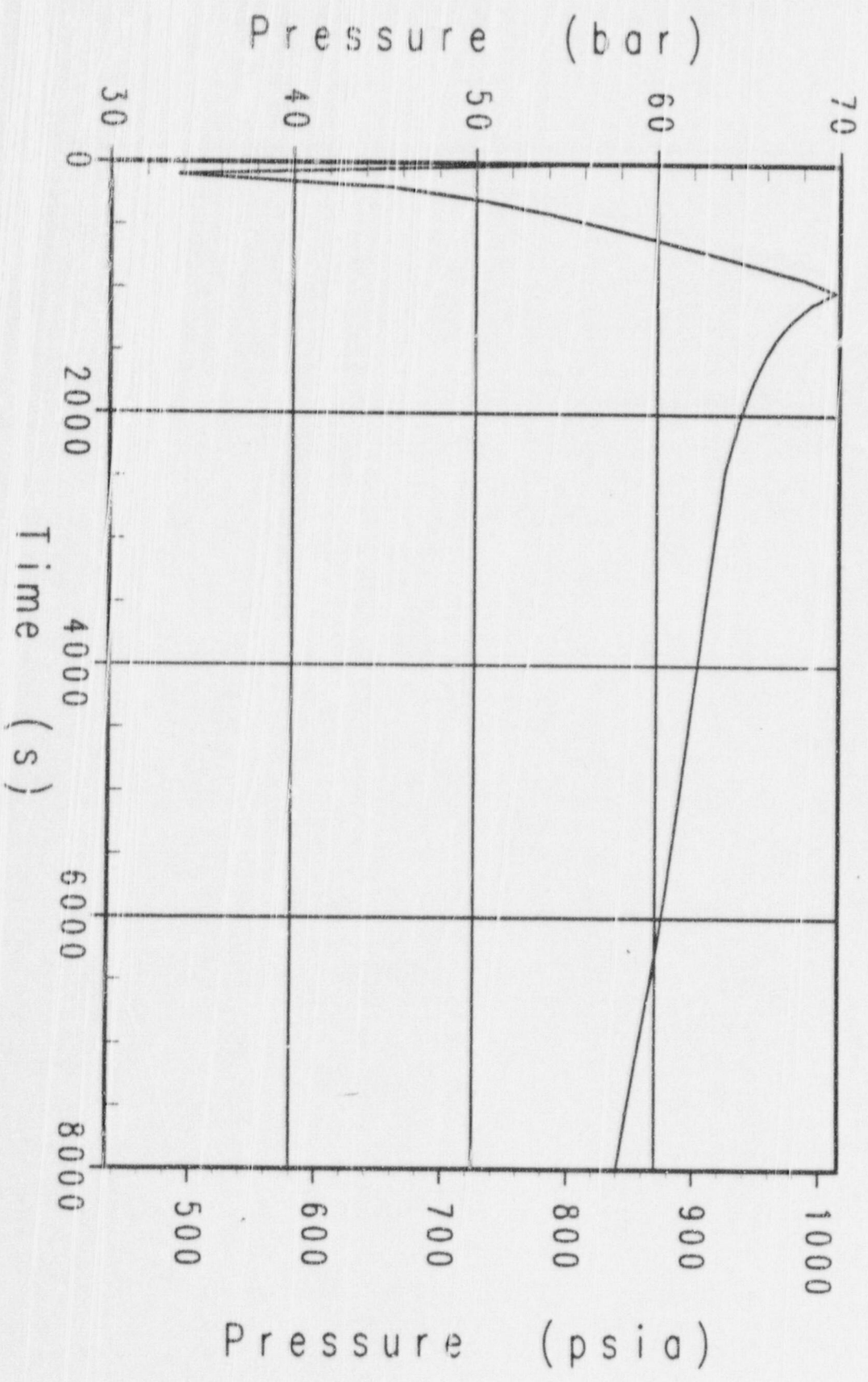

Case x4d2 AP600 Success Criteria MAAP4 Analysis
Primary System Pressure

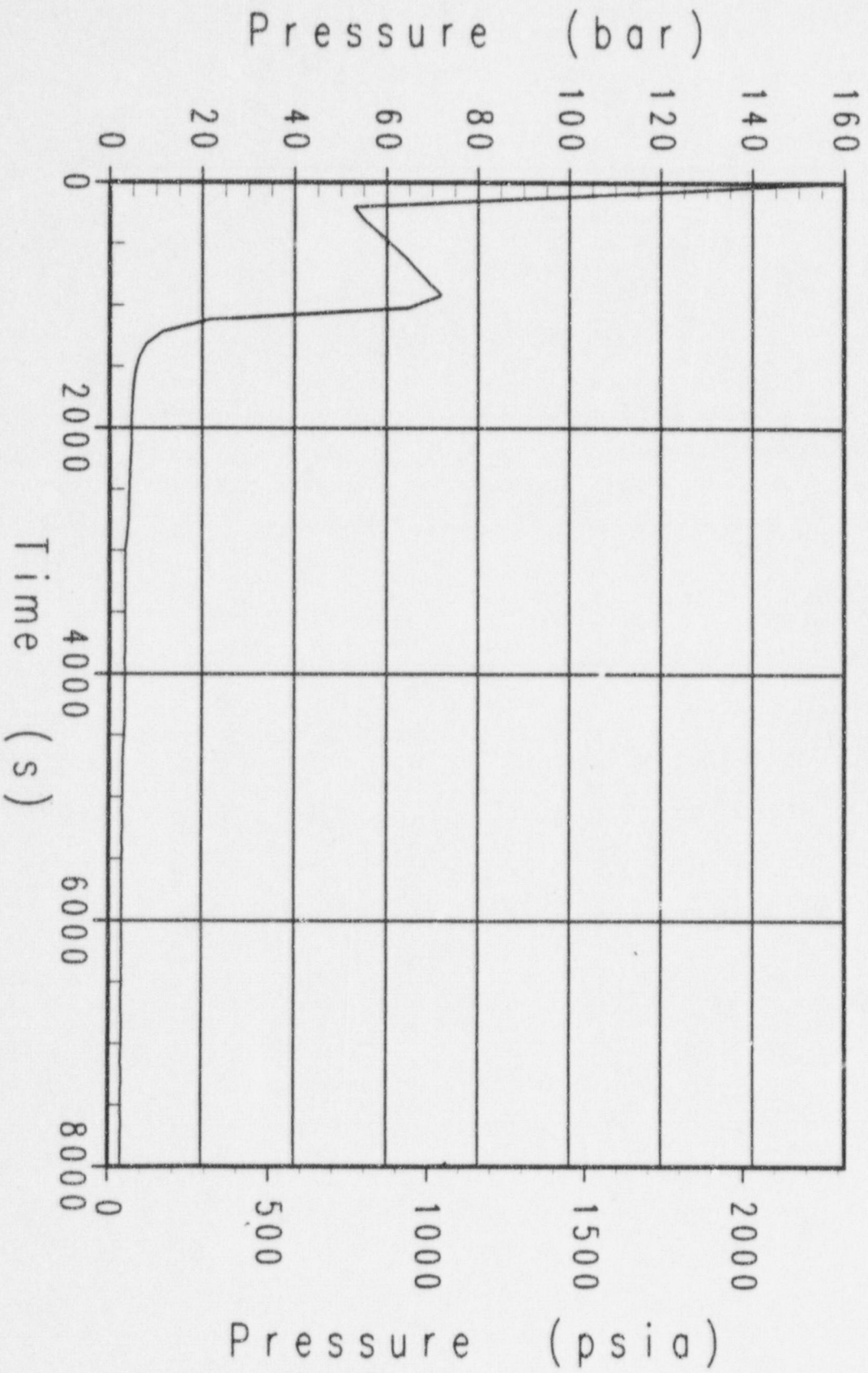

Case x4d2 AP600 Success Criteria MAAP4 Analysis
Containment Pressure

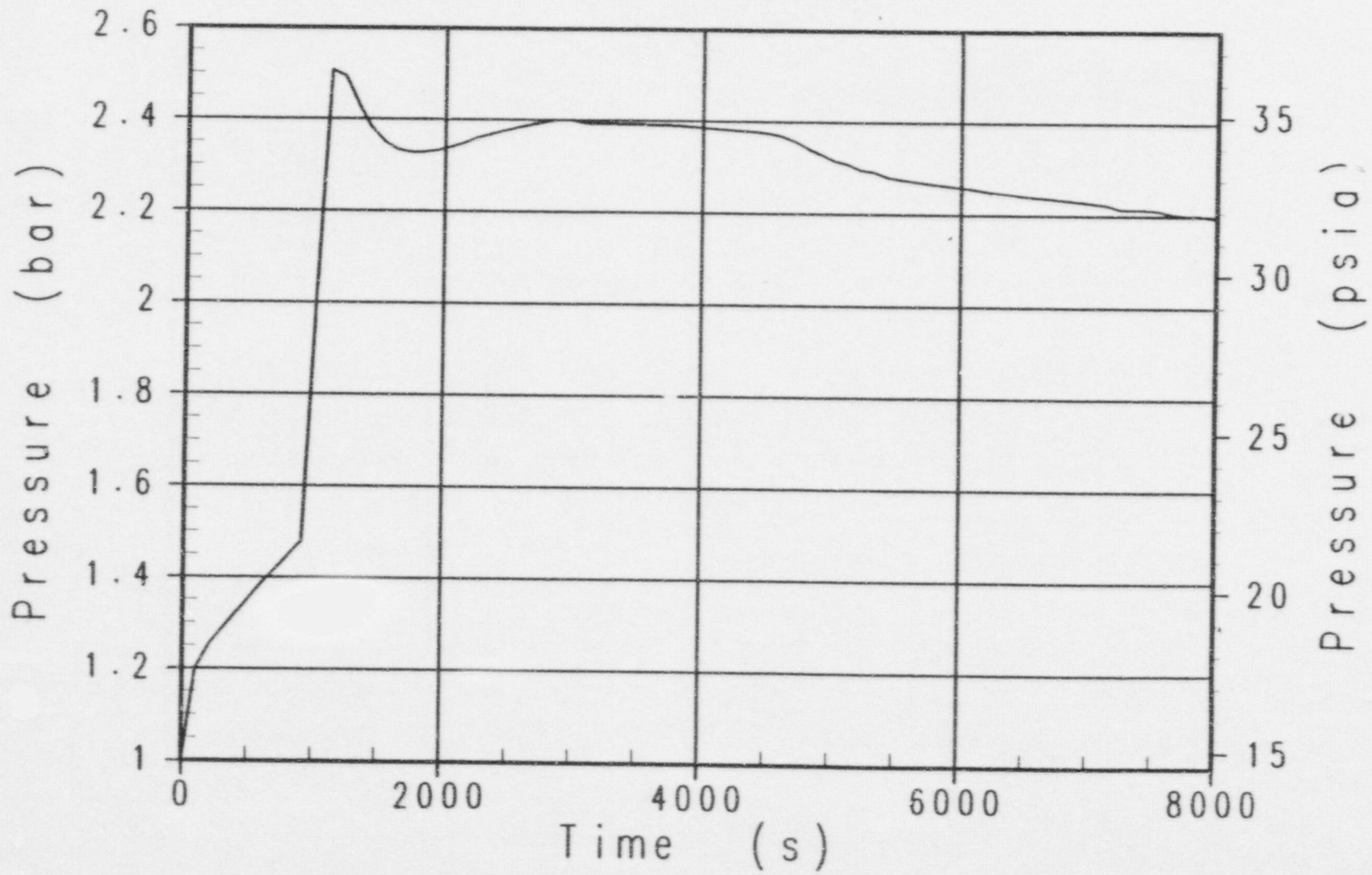

Case x4d2 AP600 Success Criteria MAAP4 Analysis
Unbroken Loop Steam Generator Pressure

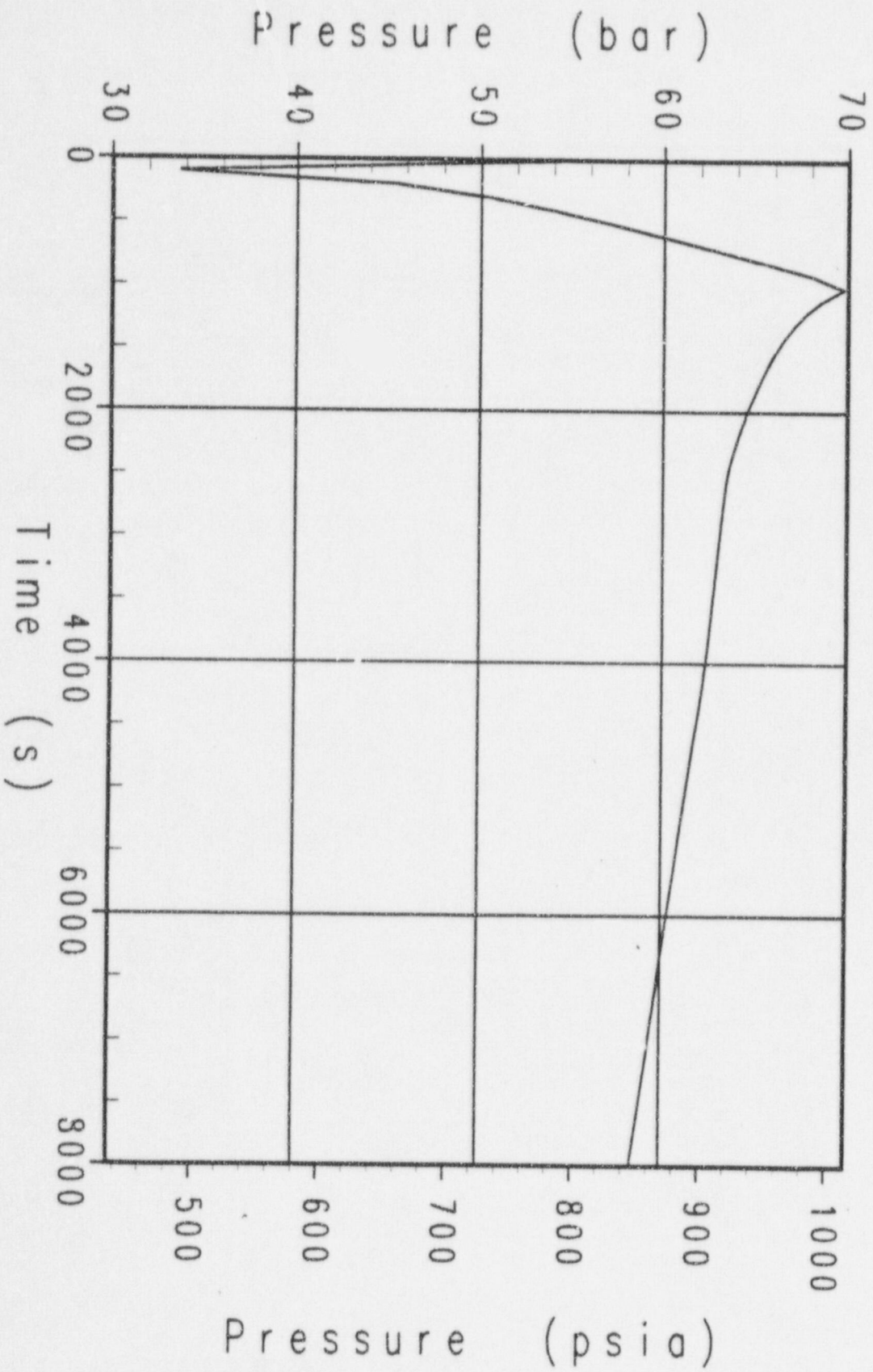

Case x4d2 AP600 Success Criteria MAAP4 Analysis
Decay Power

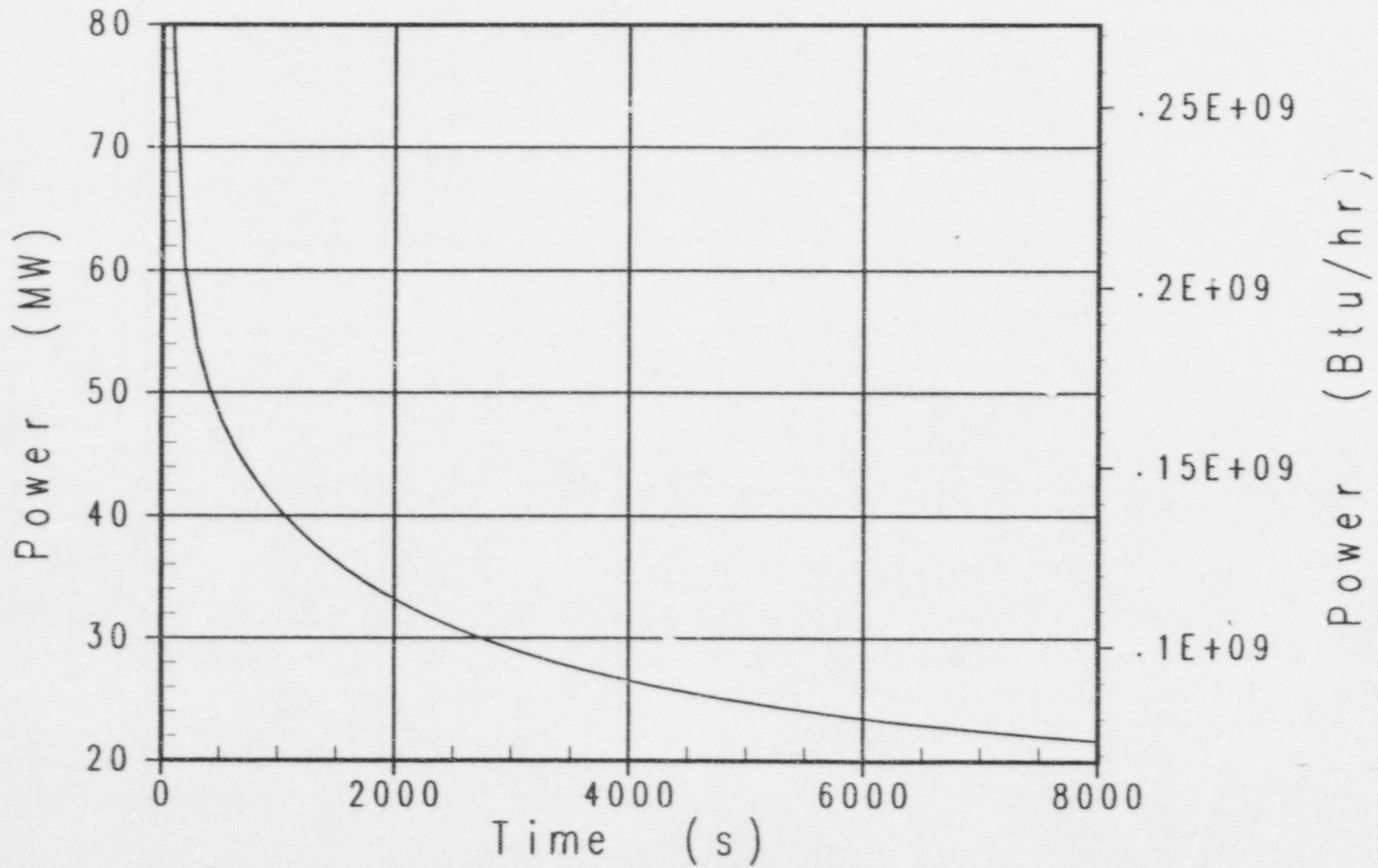

Case x4d2 AP600 Success Criteria MAAP4 Analysis
PRHR Heat Removal Rate

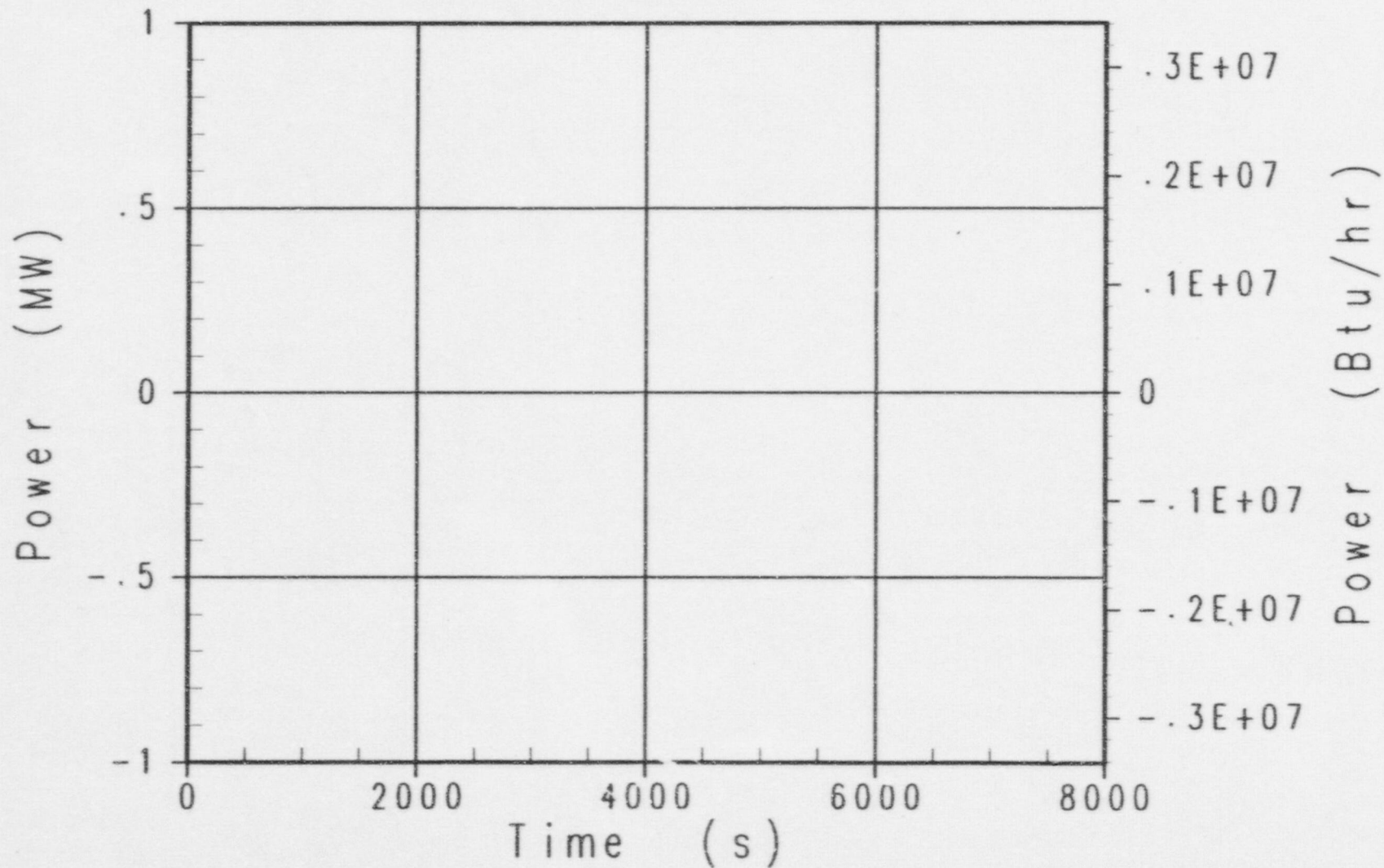

Case x4d2 AP600 Success Criteria MAAP4 Analysis
Peak Temperature in the Core

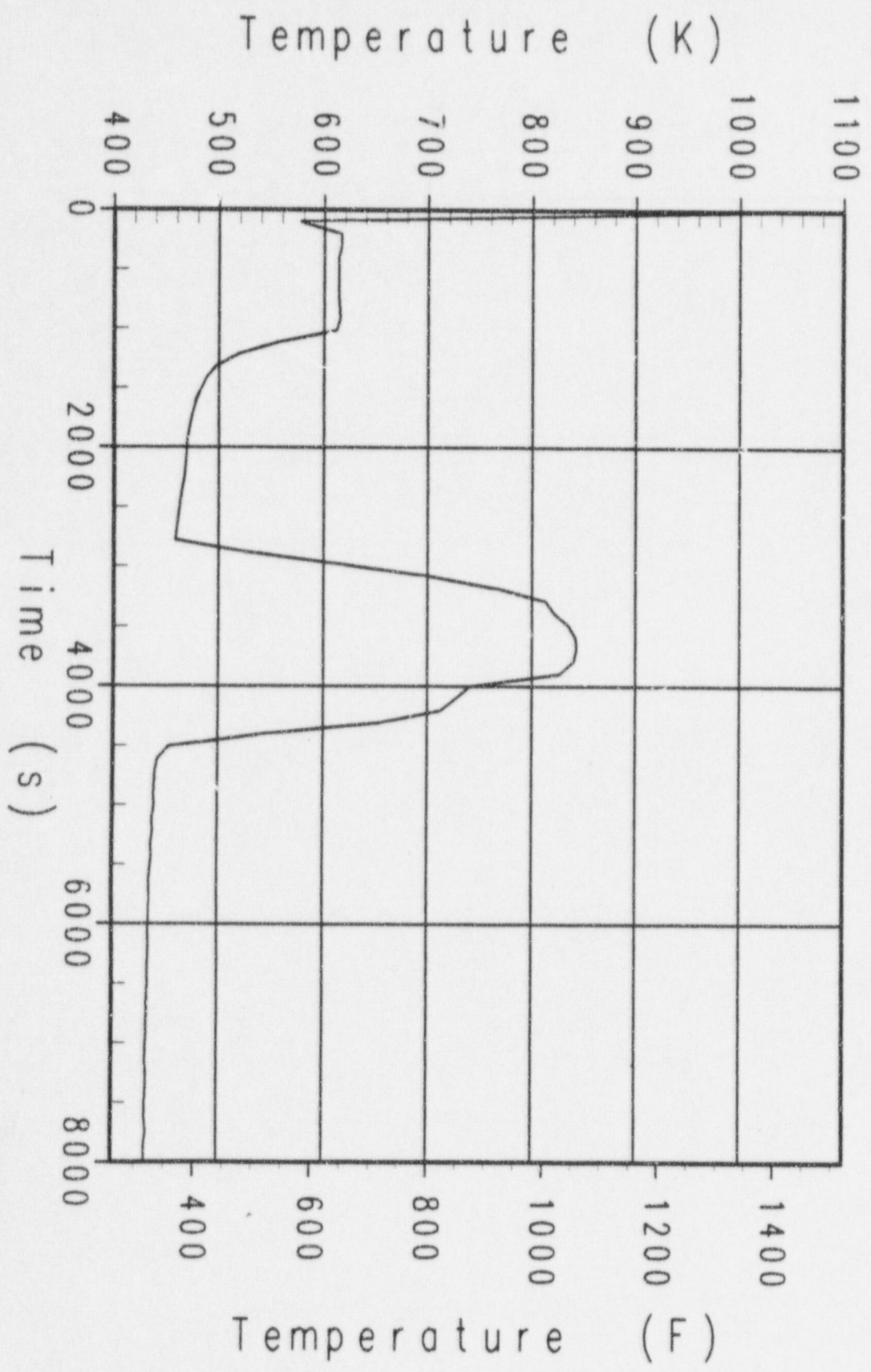

Case x4d2 AP600 Success Criteria MAAP4 Analysis
Cold Leg Water Temperature

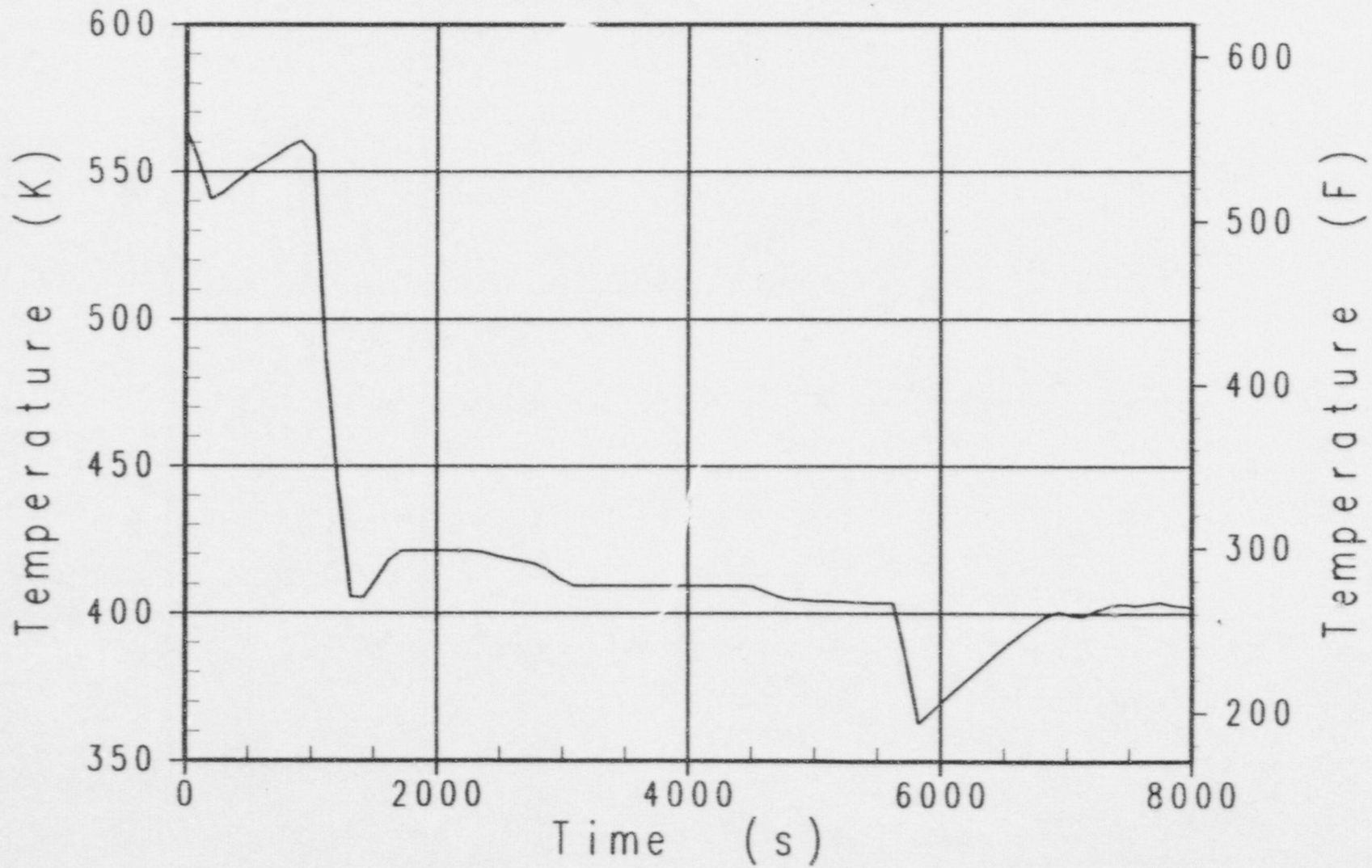

Case x4d2 AP600 Success Criteria MAAP4 Analysis
Core Water Temperature

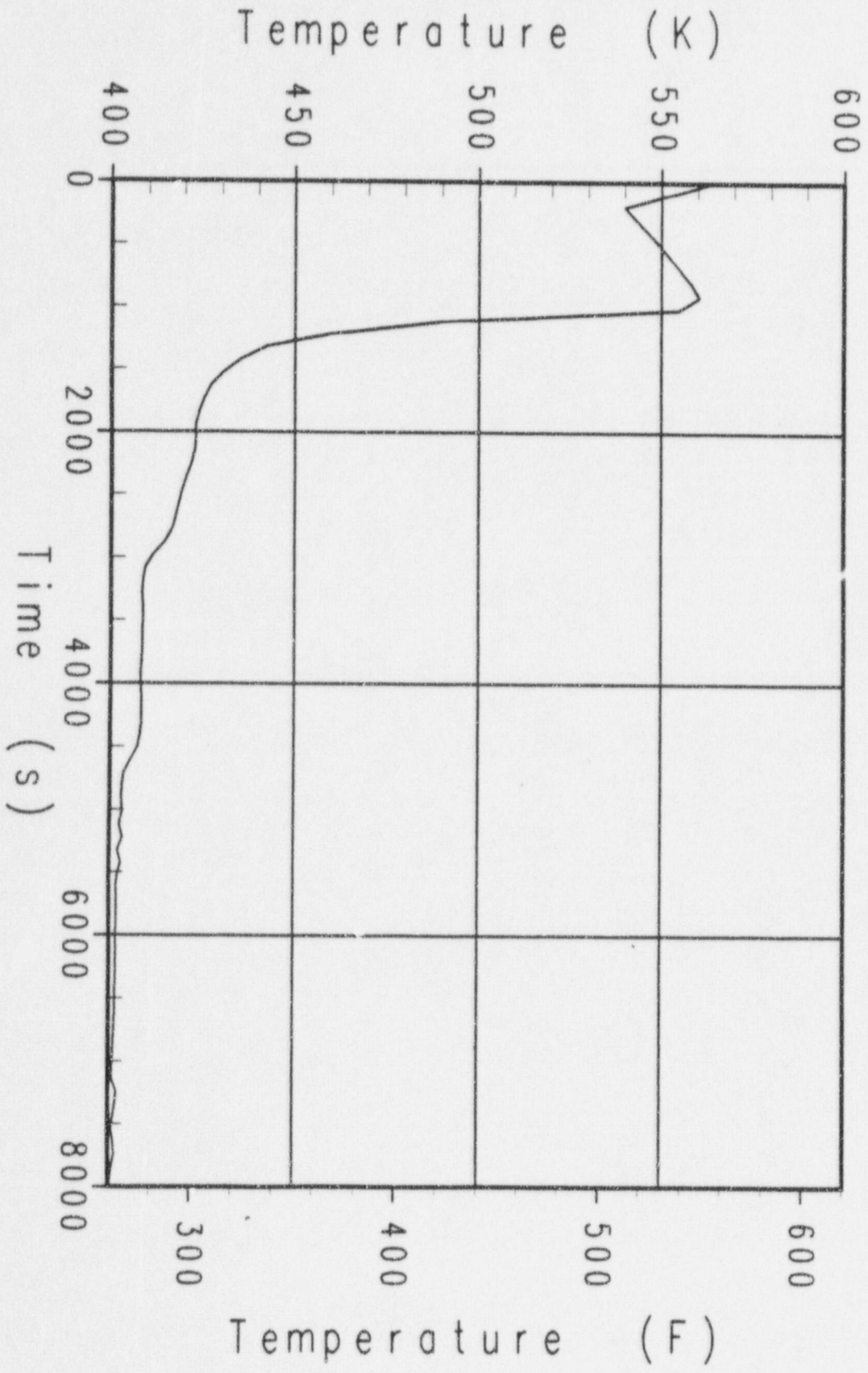

Case x4d2 AP600 Success Criteria MAAP4 Analysis
RPV Downcomer Water Temperature

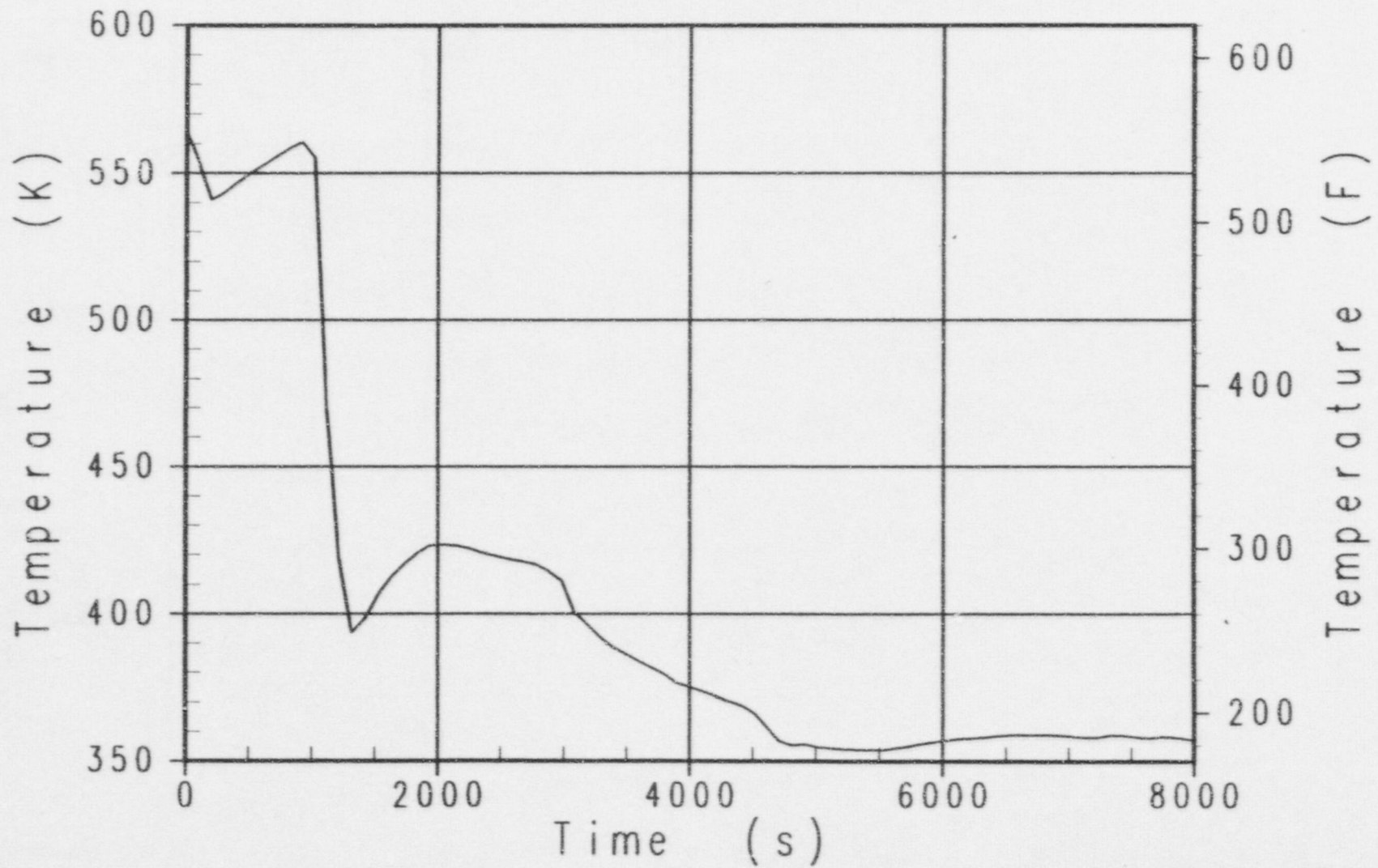

Case x4d2 AP600 Success Criteria MAAP4 Analysis
IRWST Water Temperature

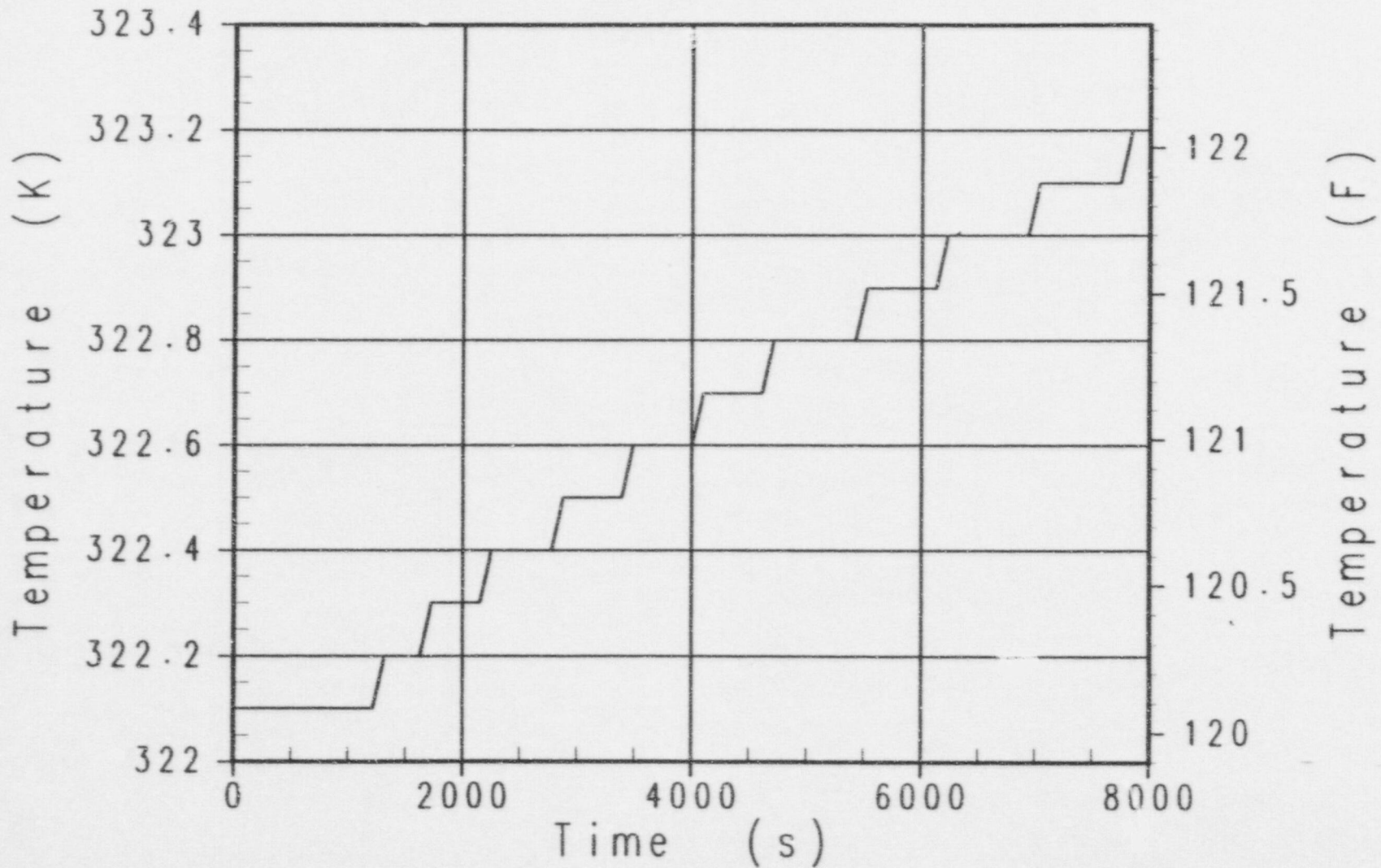

Case x4d2 AP600 Success Criteria MAAP4 Analysis
Accumulator and NRHR Injection Flowrate

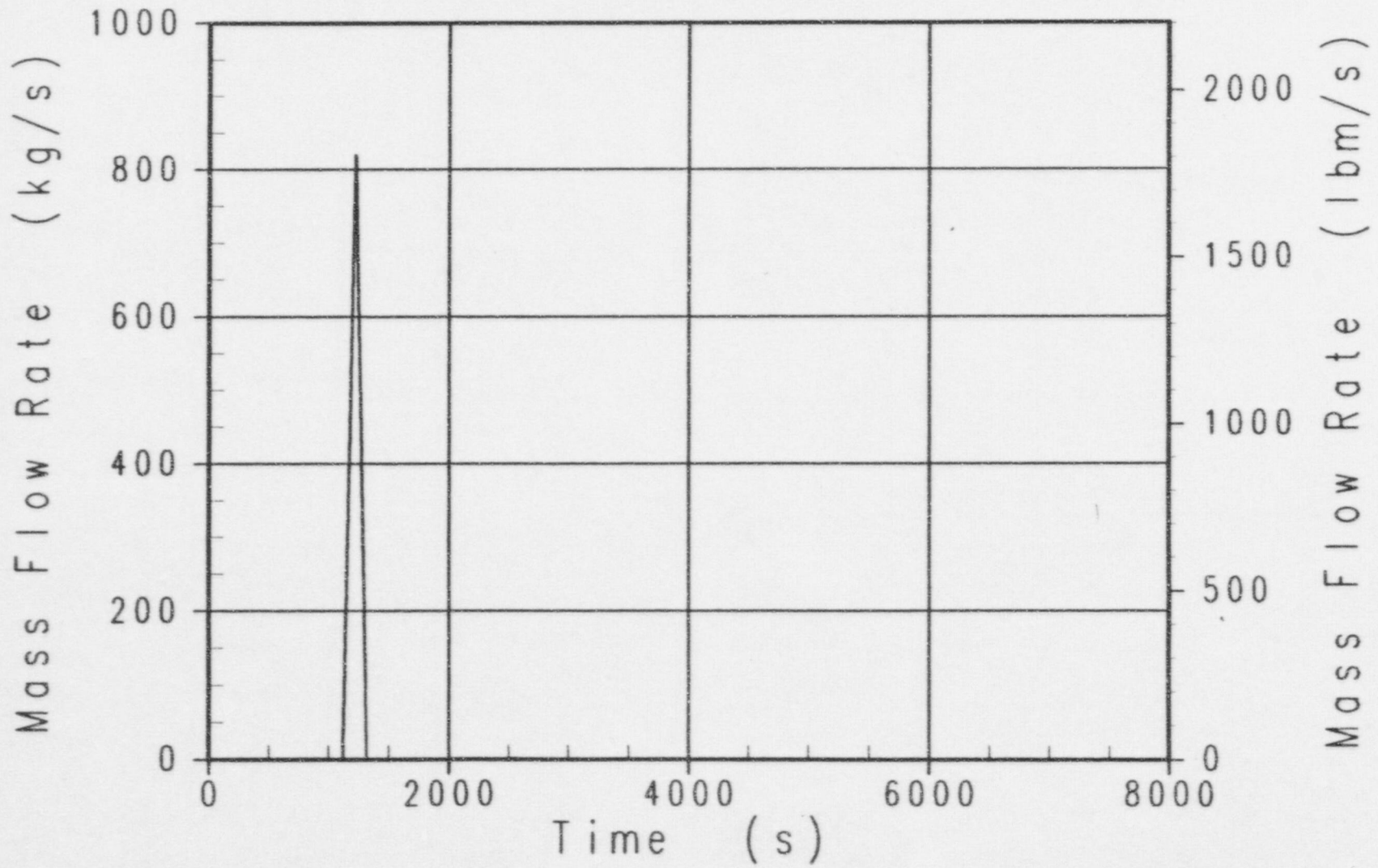

Case x4d2 AP600 Success Criteria MAAP4 Analysis
RCS Break Gas Flowrate

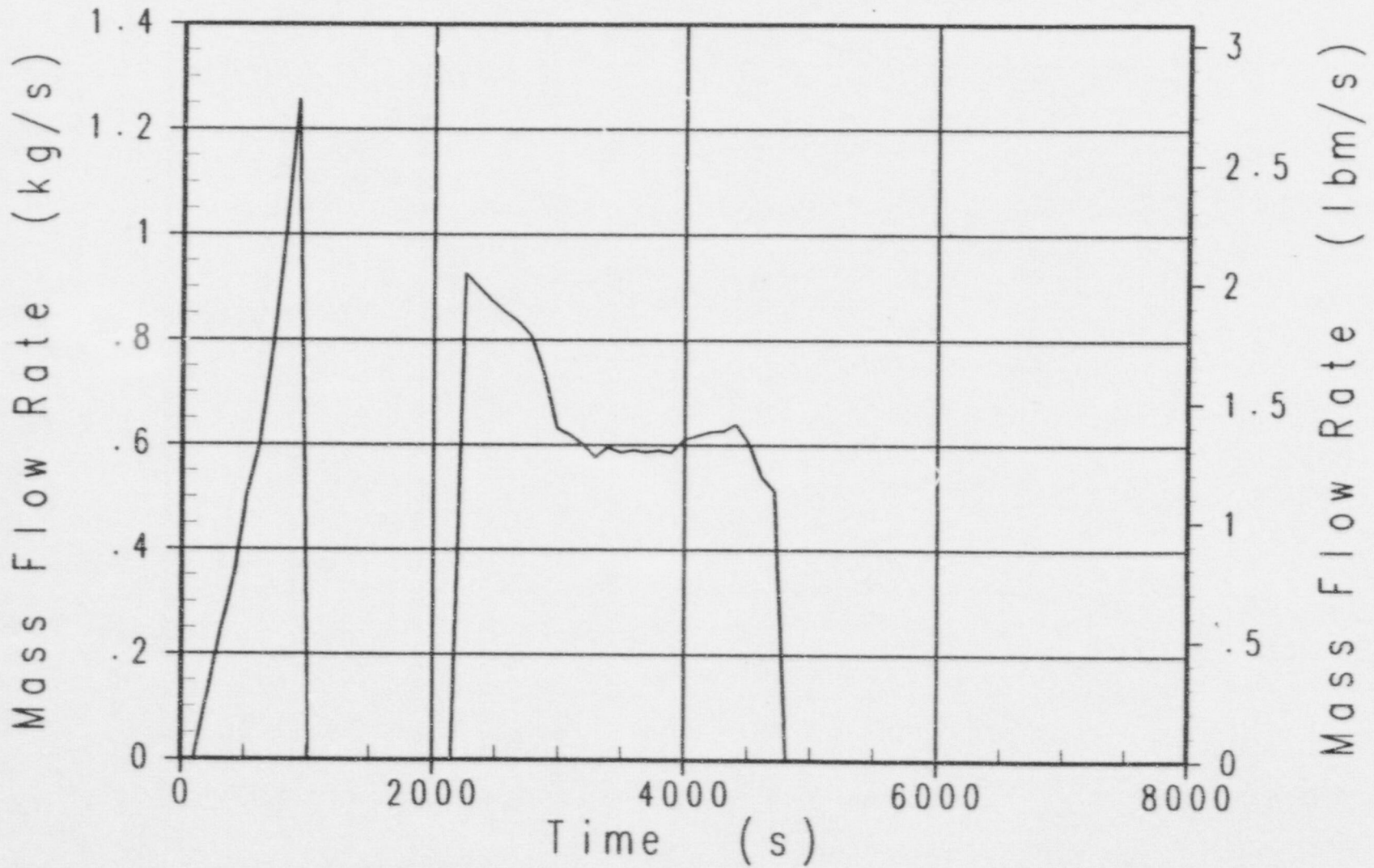

Case x4d2 AP600 Success Criteria MAAP4 Analysis
ADS Stage 4 Gas Flowrate

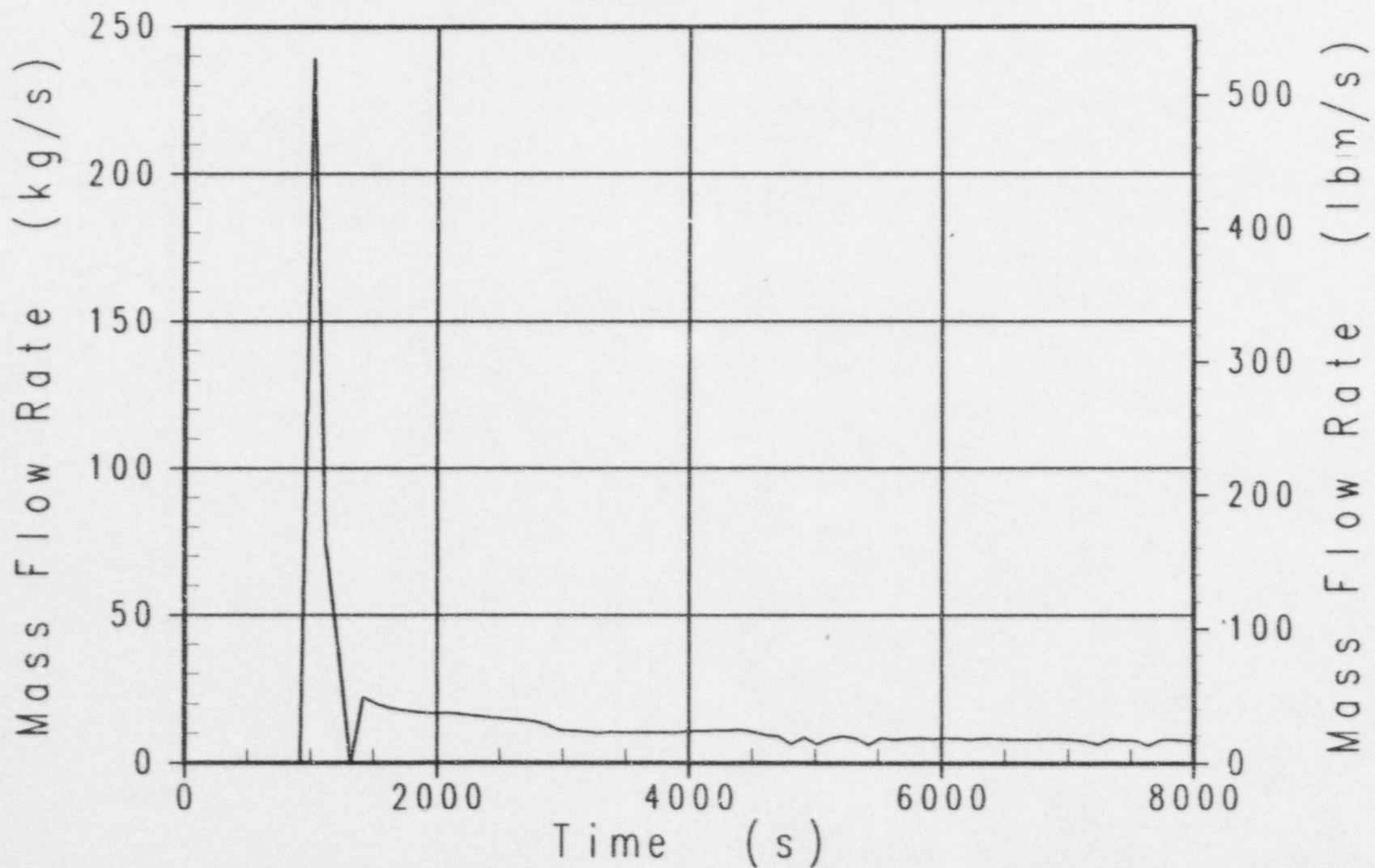

Case x4d2 AP600 Success Criteria MAAP4 Analysis
Safety Valve and ADS Stages 1-3 Gas Flowrate

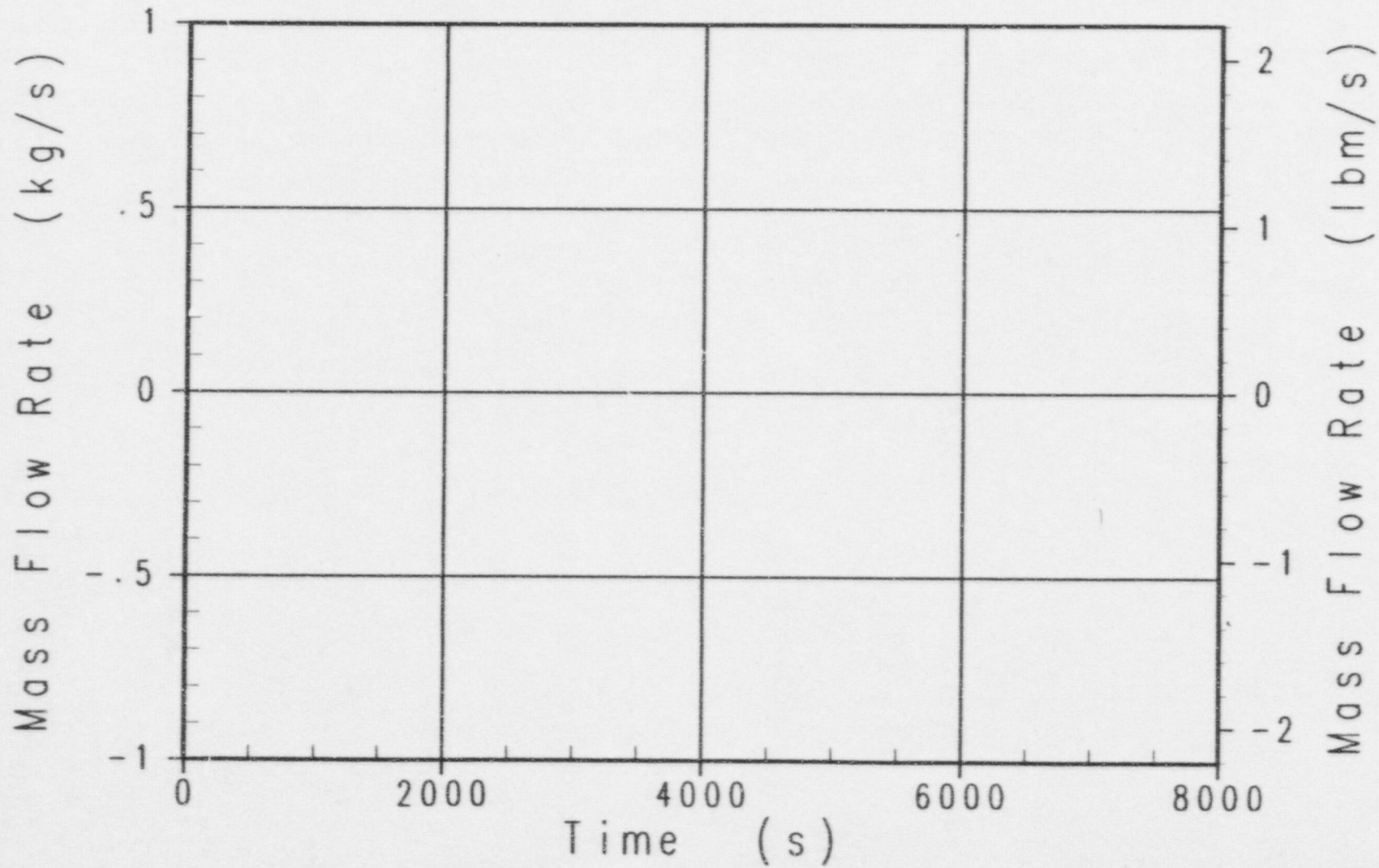

Case x4d2 AP600 Success Criteria MAAP4 Analysis
RCS Break Liquid Flowrate

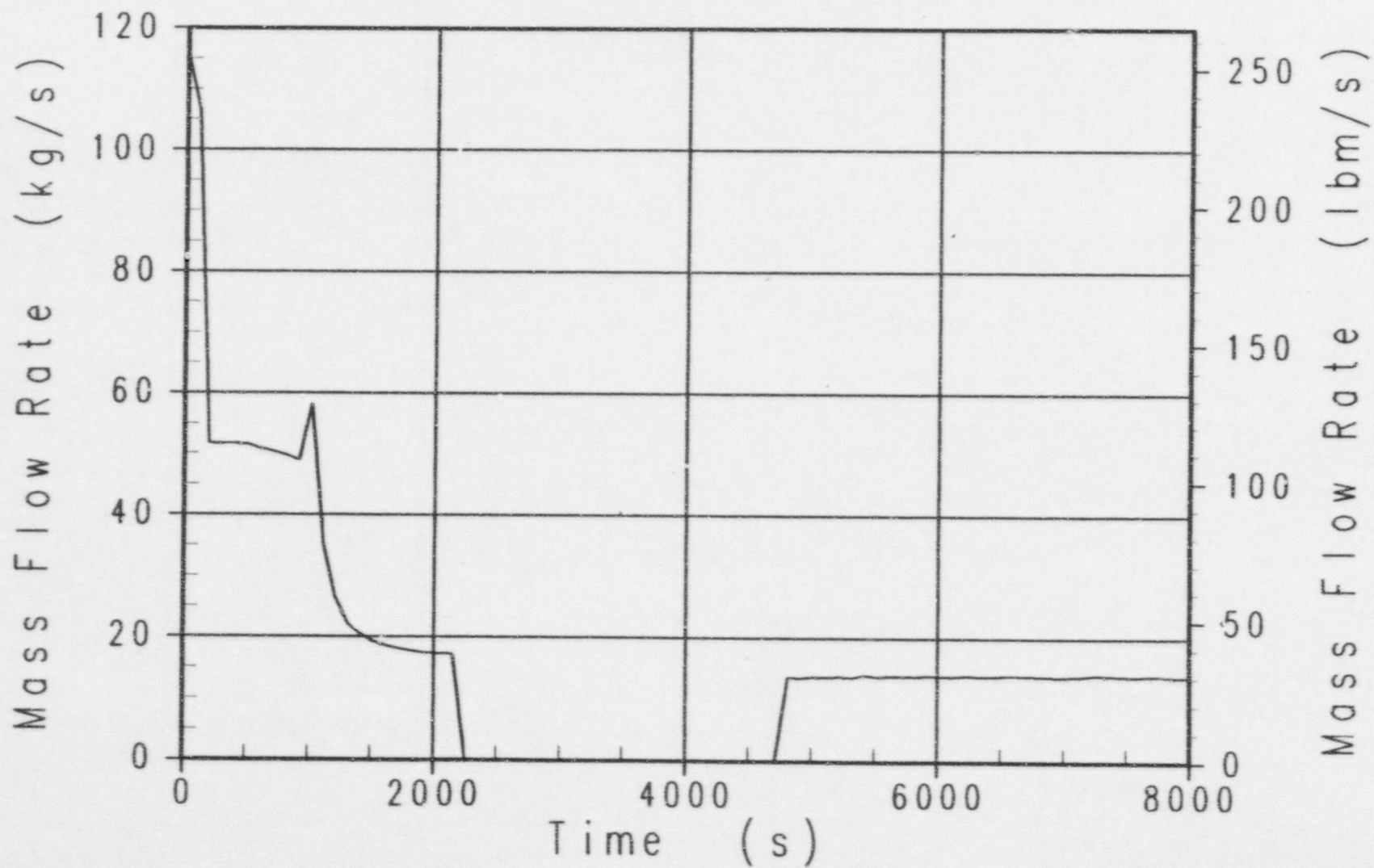

Case x4d2 AP600 Success Criteria MAAP4 Analysis
ADS Stage 4 Liquid Flowrate

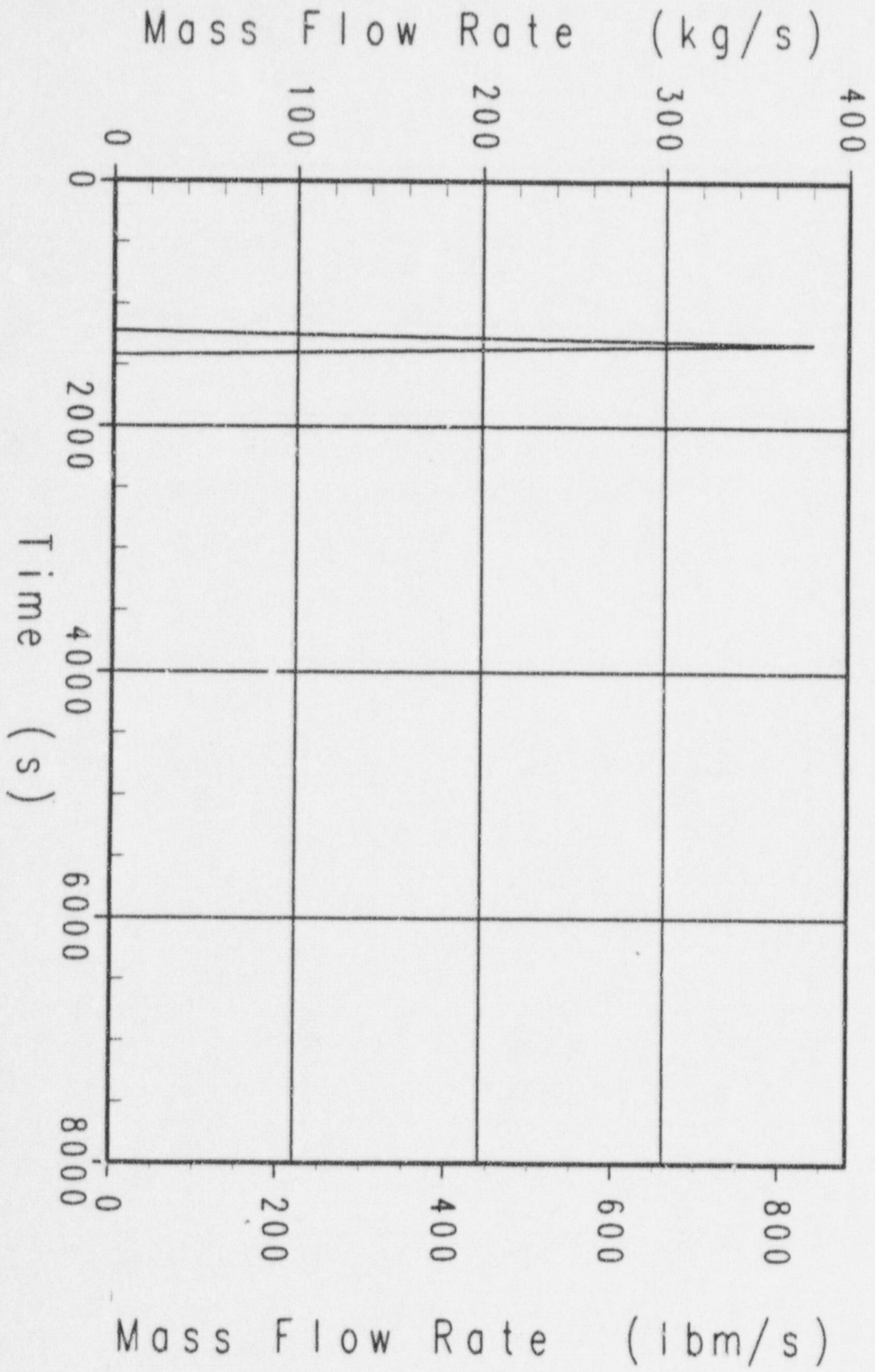

Case x4d2 AP600 Success Criteria MAA4 Analysis
IRWST Injection Flowrate (neg. means into RCS)

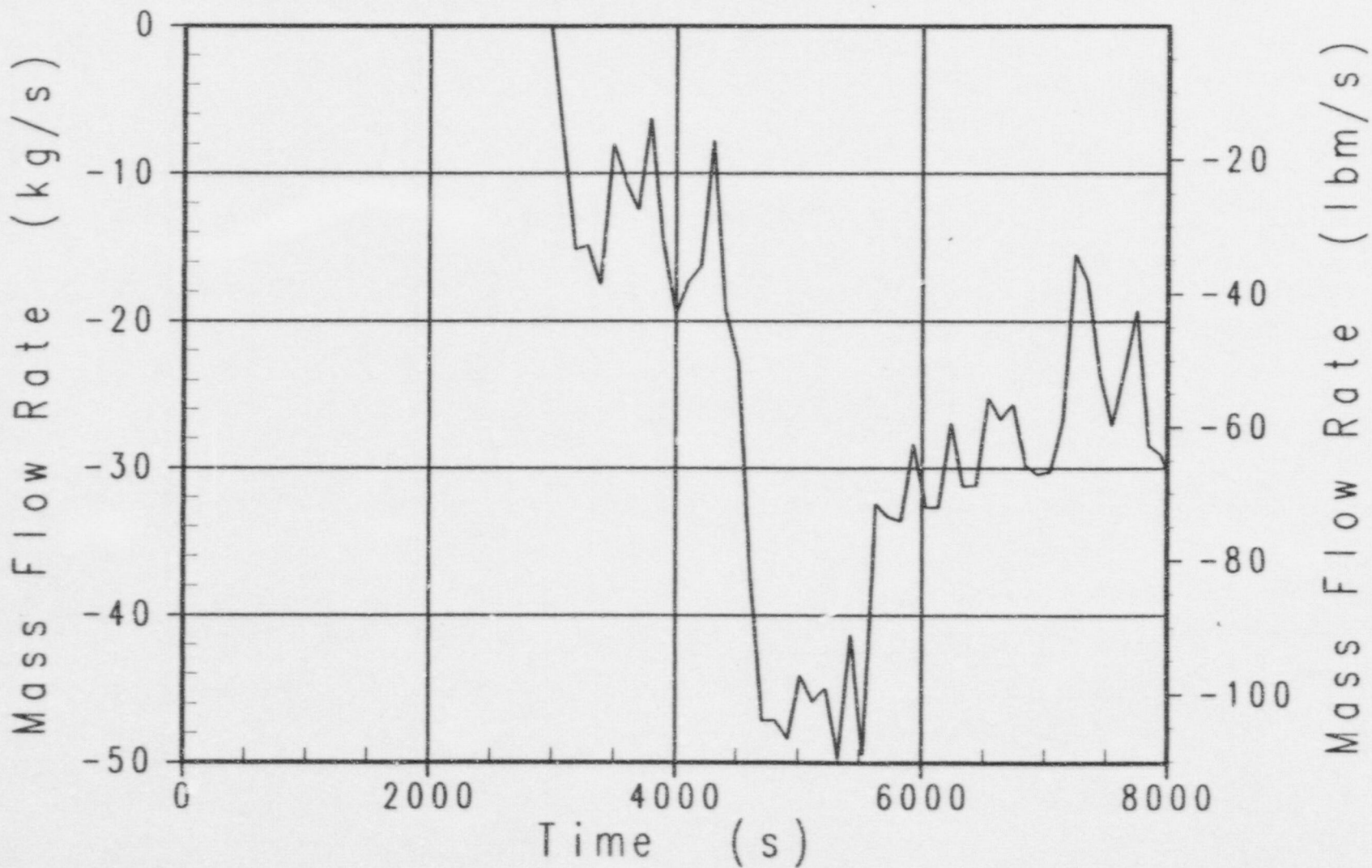

Case x4d2 AP600 Success Criteria MAAP4 Analysis
CMT-1 Injection Flowrate

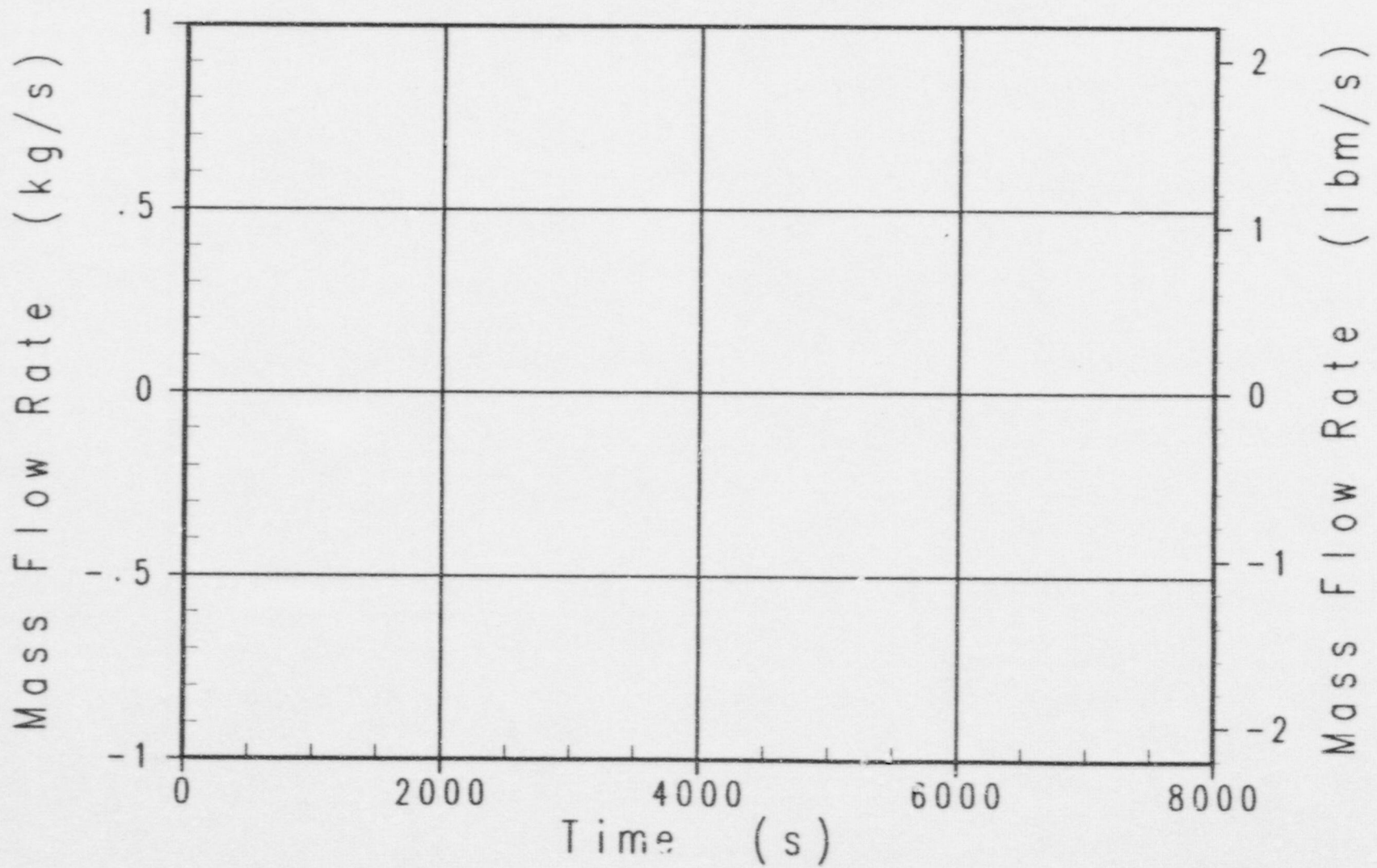

Case x4d2 AP600 Success Criteria MAA4 Analysis
Safety Valve and ADS Stages 1-3 Liquid Flowrate

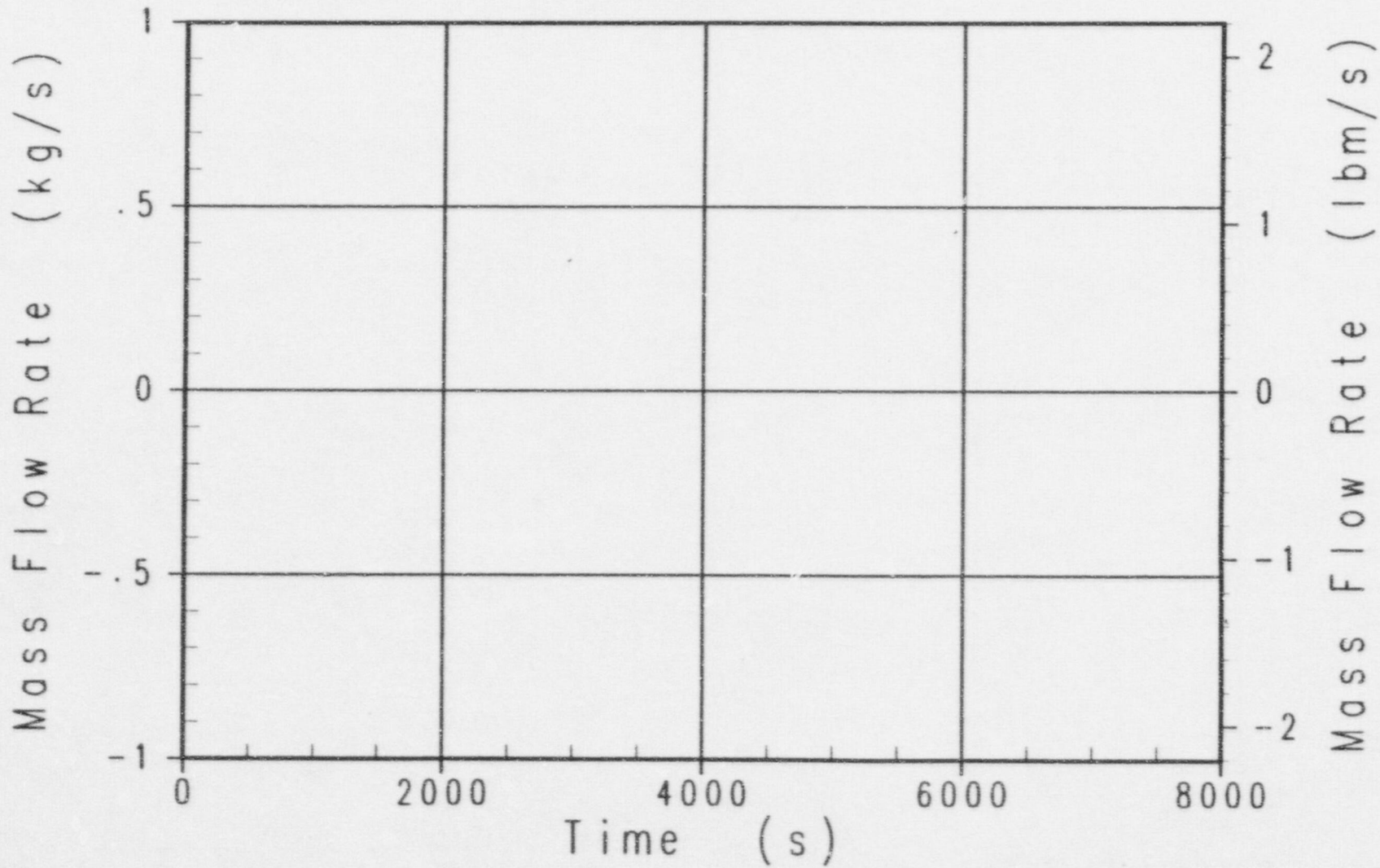

Case x4d2 AP600 Success Criteria MAAP4 Analysis
CMT-1 Water Level

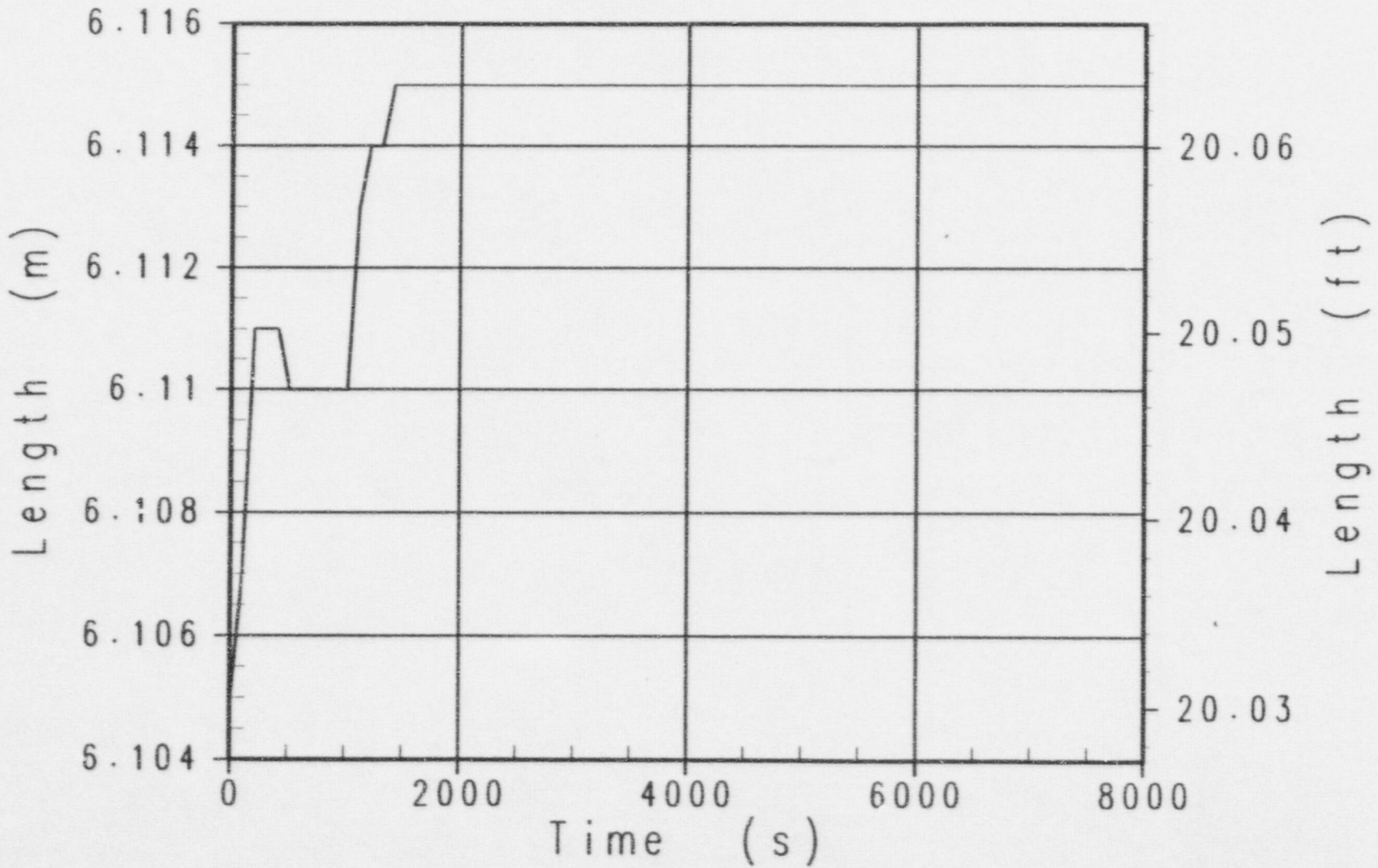

Case x4d2 AP600 Success Criteria MAAP4 Analysis
Pressurizer Water Level (From Pzr Bottom)

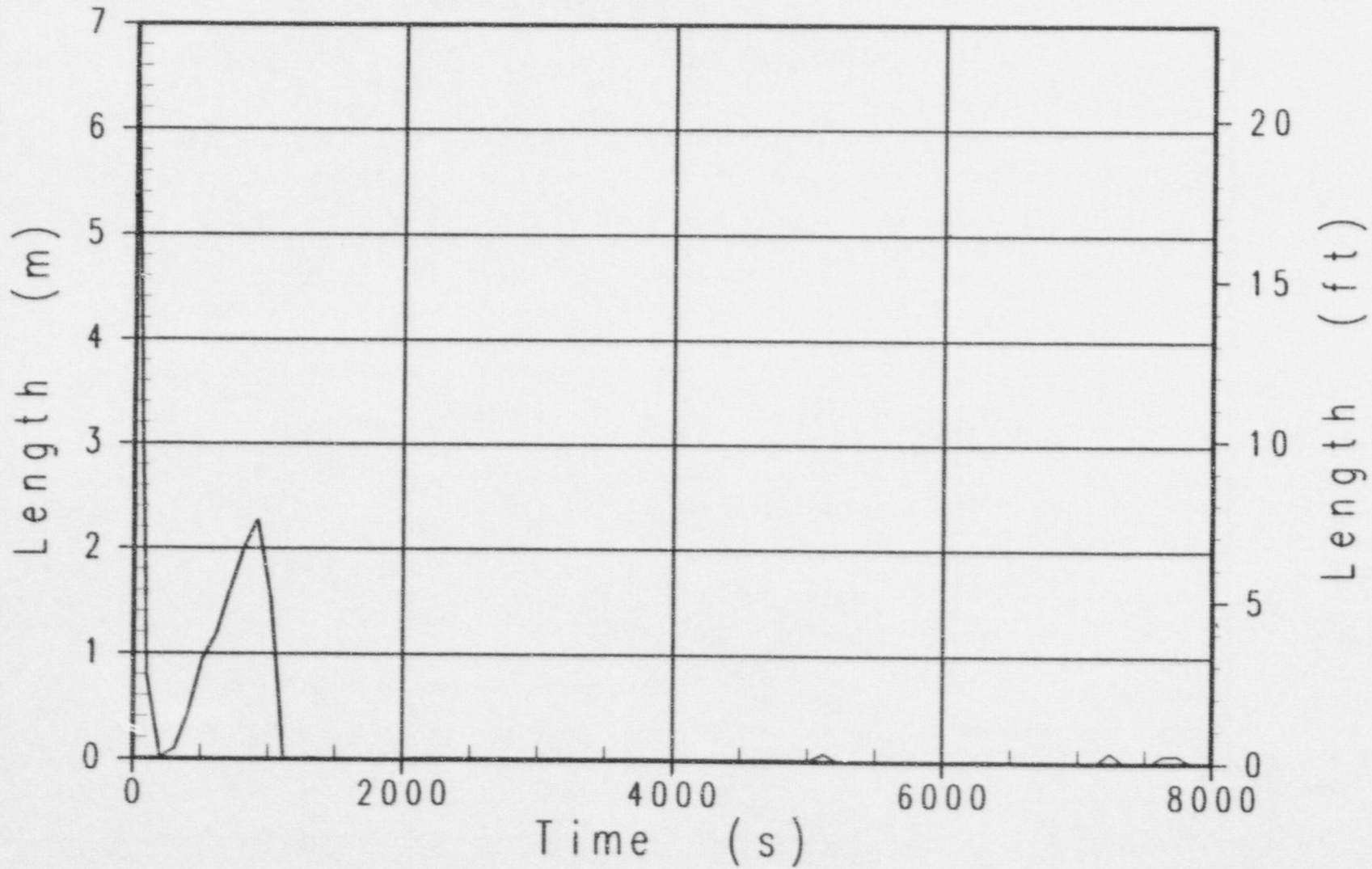

Case x4d3 AP600 Success Criteria MAAP4 Analysis
Broken Loop Steam Generator Pressure

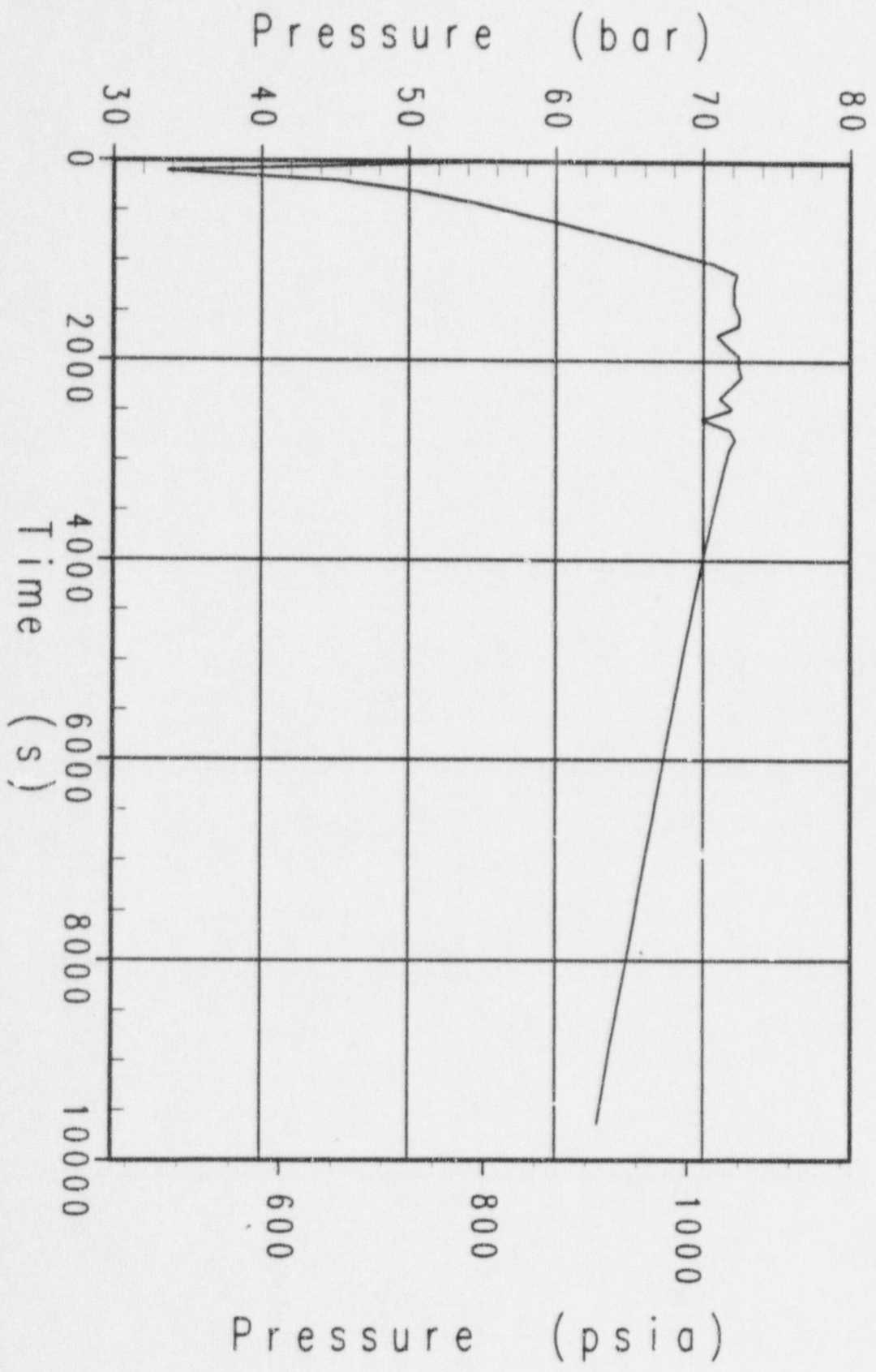

Case x4d3 AP600 Success Criteria MAAP4 Analysis
Primary System Pressure

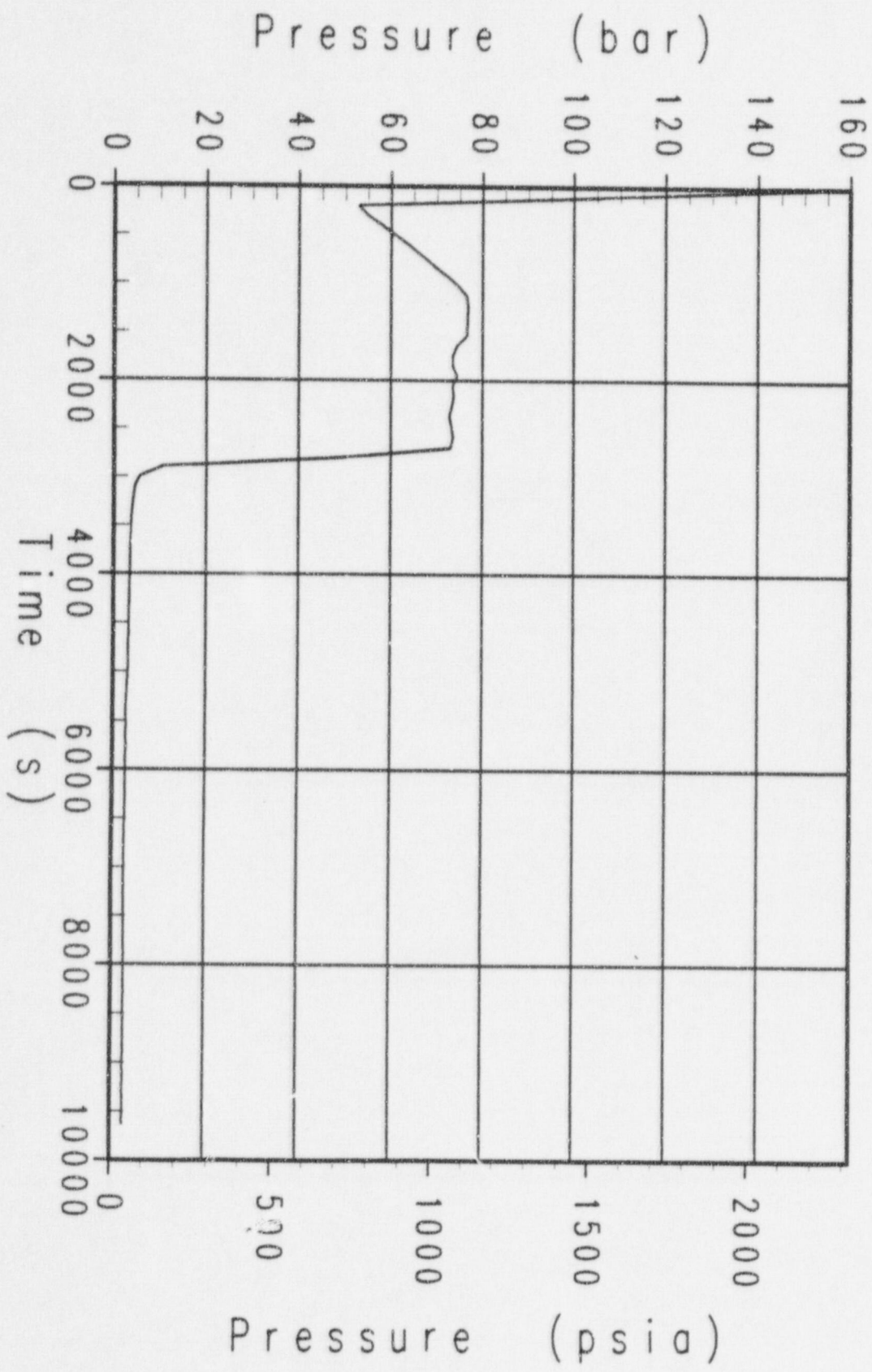

Case x4d3 AP600 Success Criteria MAAP4 Analysis
Containment Pressure

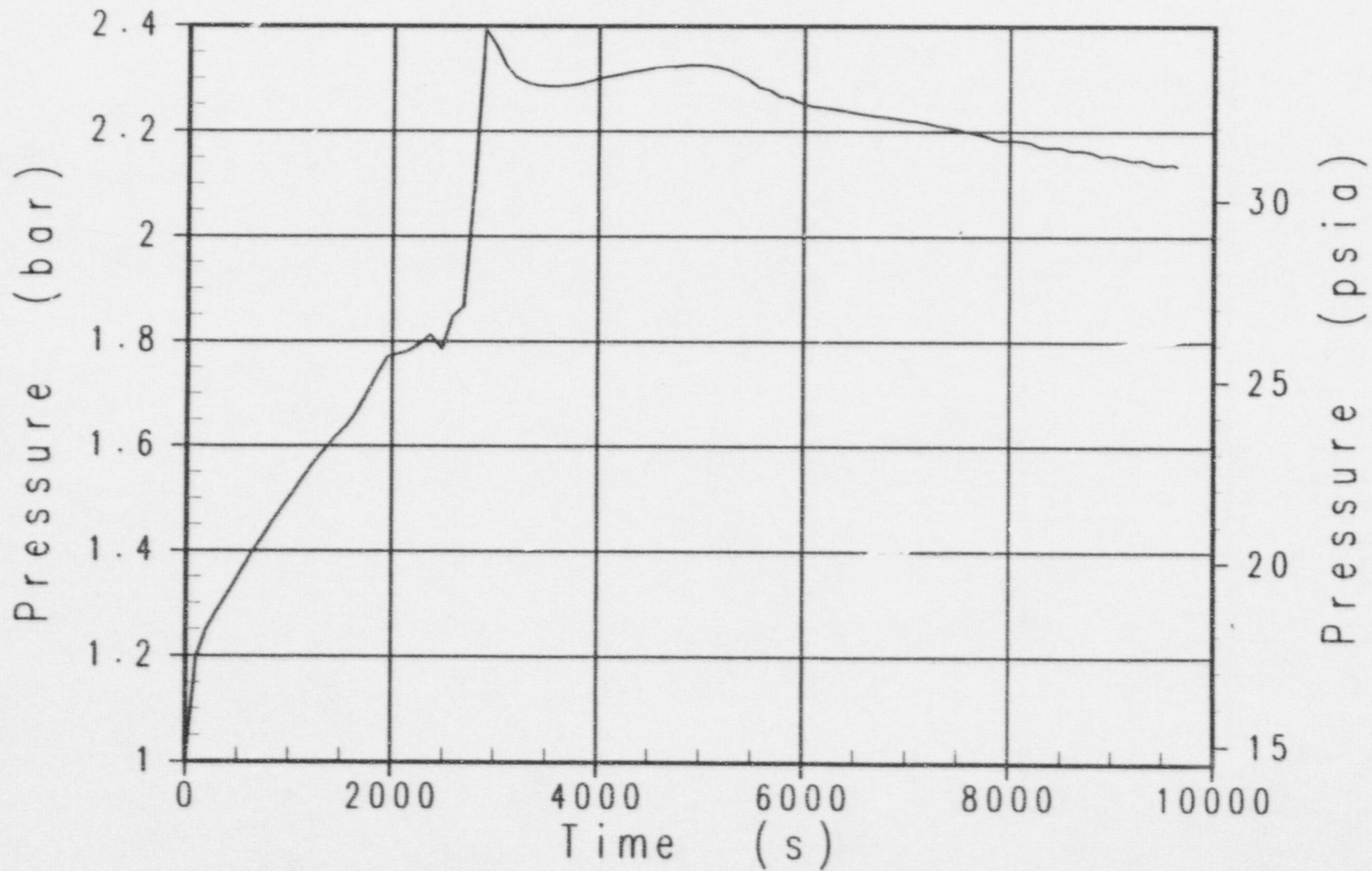

Case x4d3 AP600 Success Criteria MAPP4 Analysis
Unbroken Loop Steam Generator Pressure

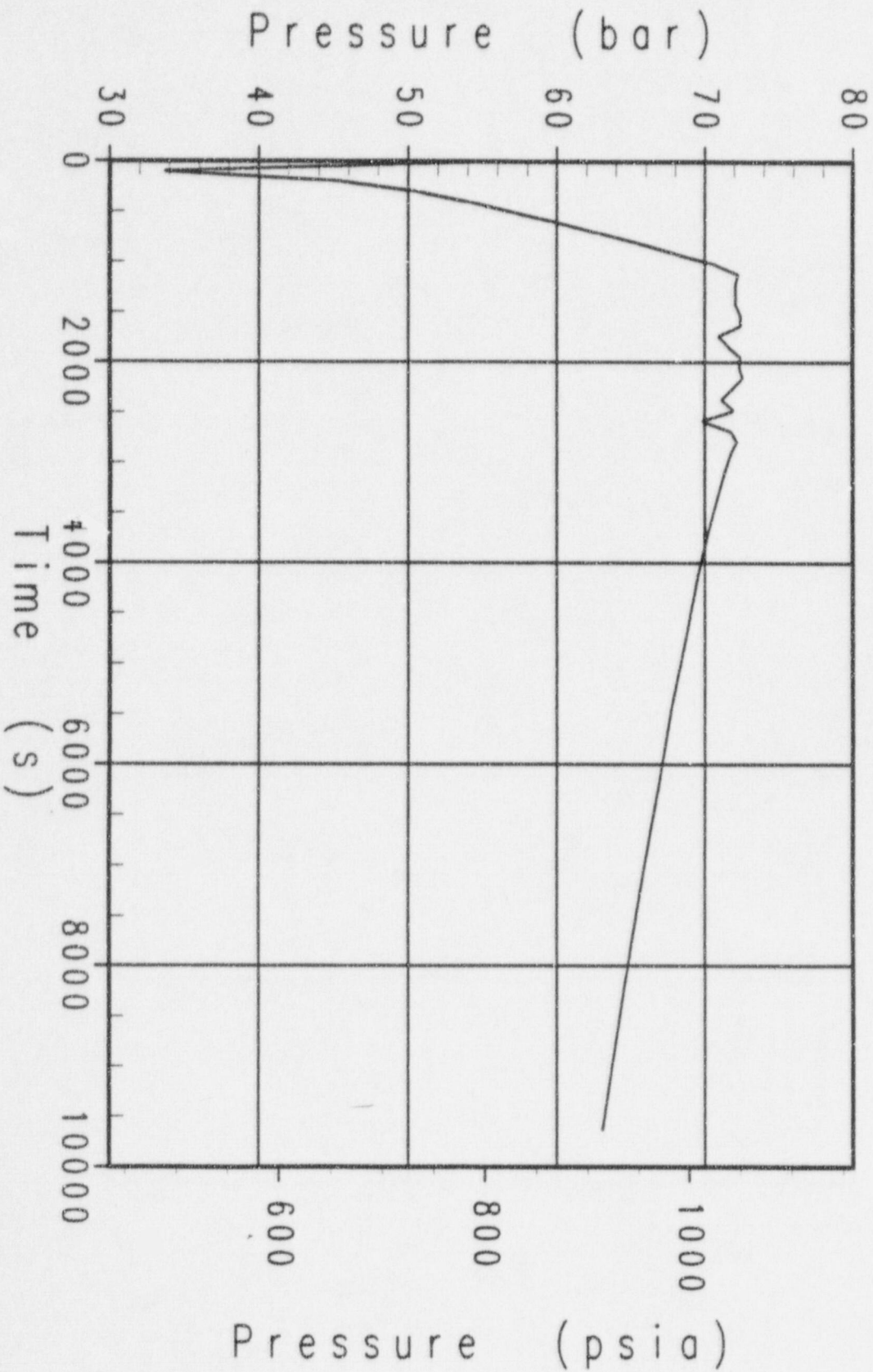

Case x4d3 AP600 Success Criteria MAAP4 Analysis
Decay Power

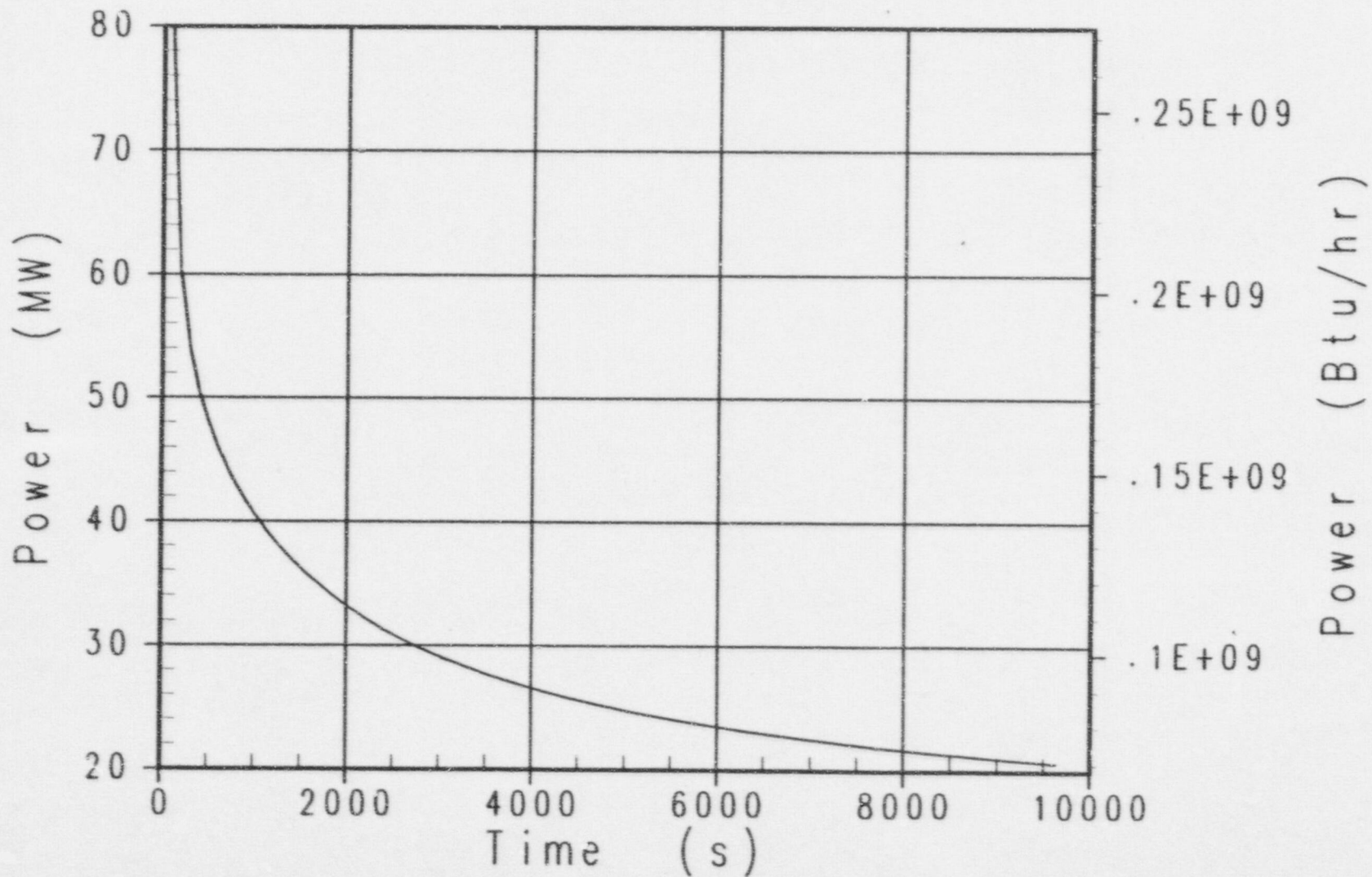

Case x4d3 AP600 Success Criteria MAAP4 Analysis
PRHR Heat Removal Rate

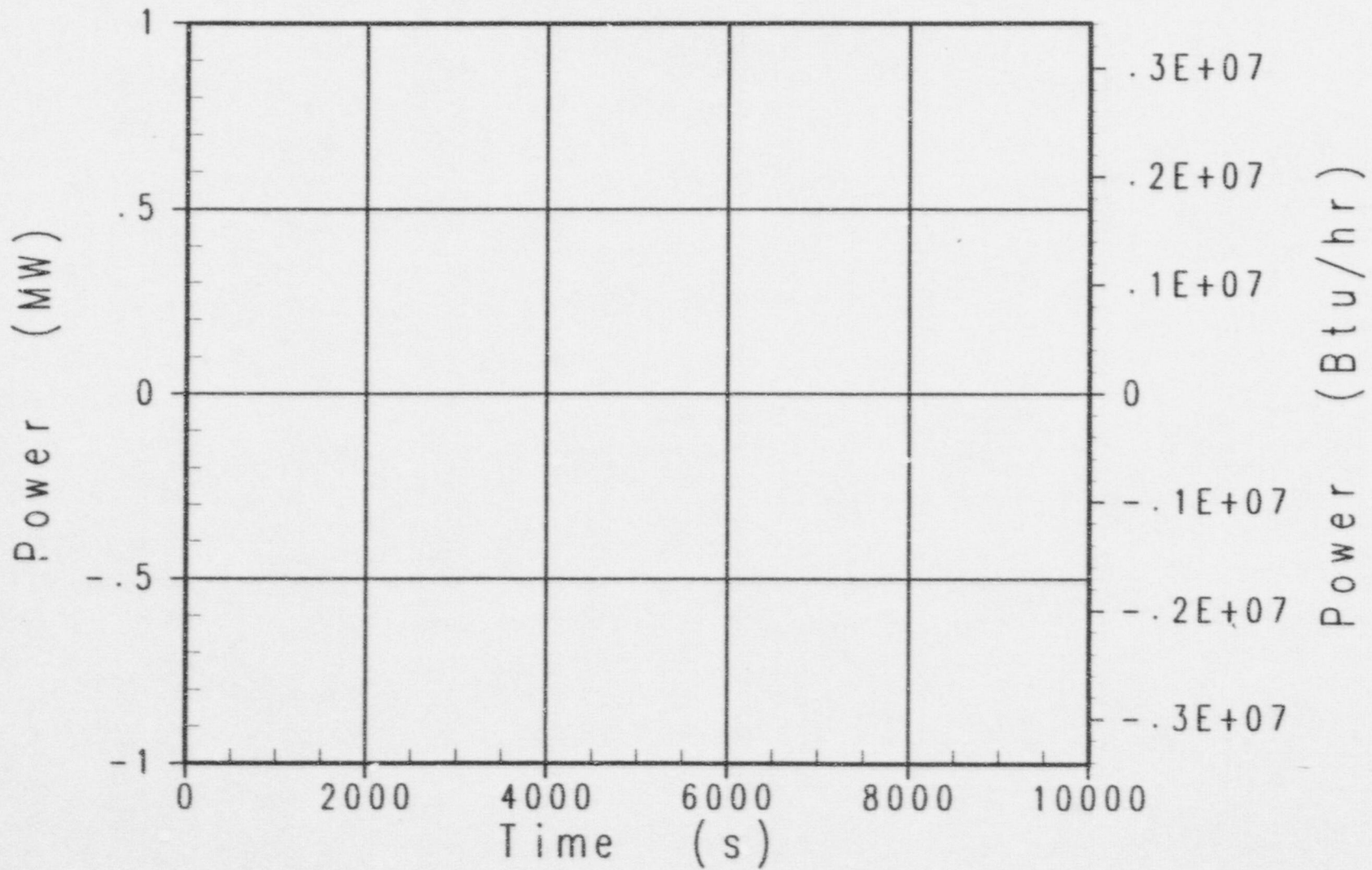

Case x4d3 AP600 Success Criteria MAAP4 Analysis
Peak Temperature in the Core

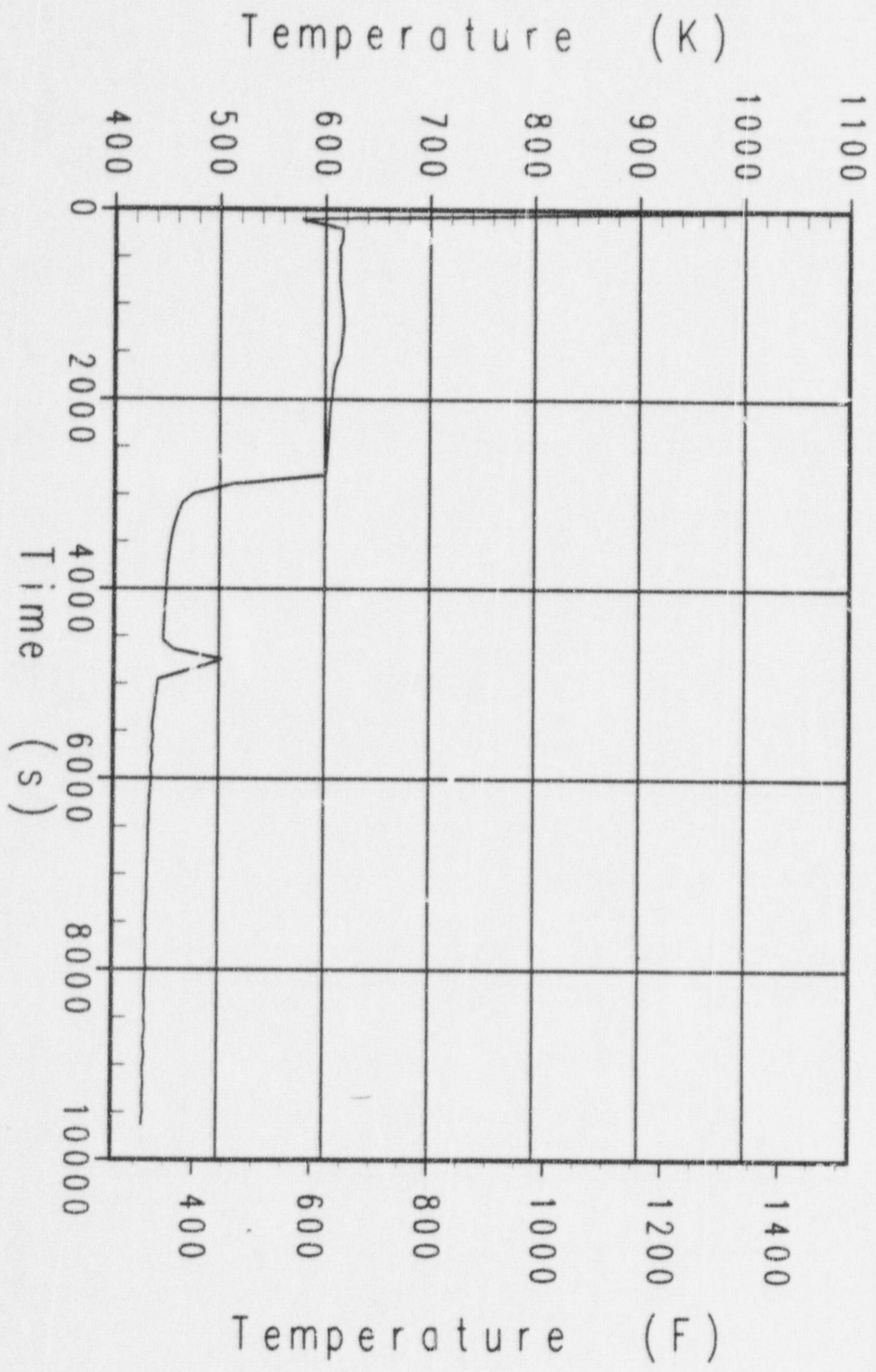

Case x4d3 AP600 Success Criteria MAAP4 Analysis
Cold Leg Water Temperature

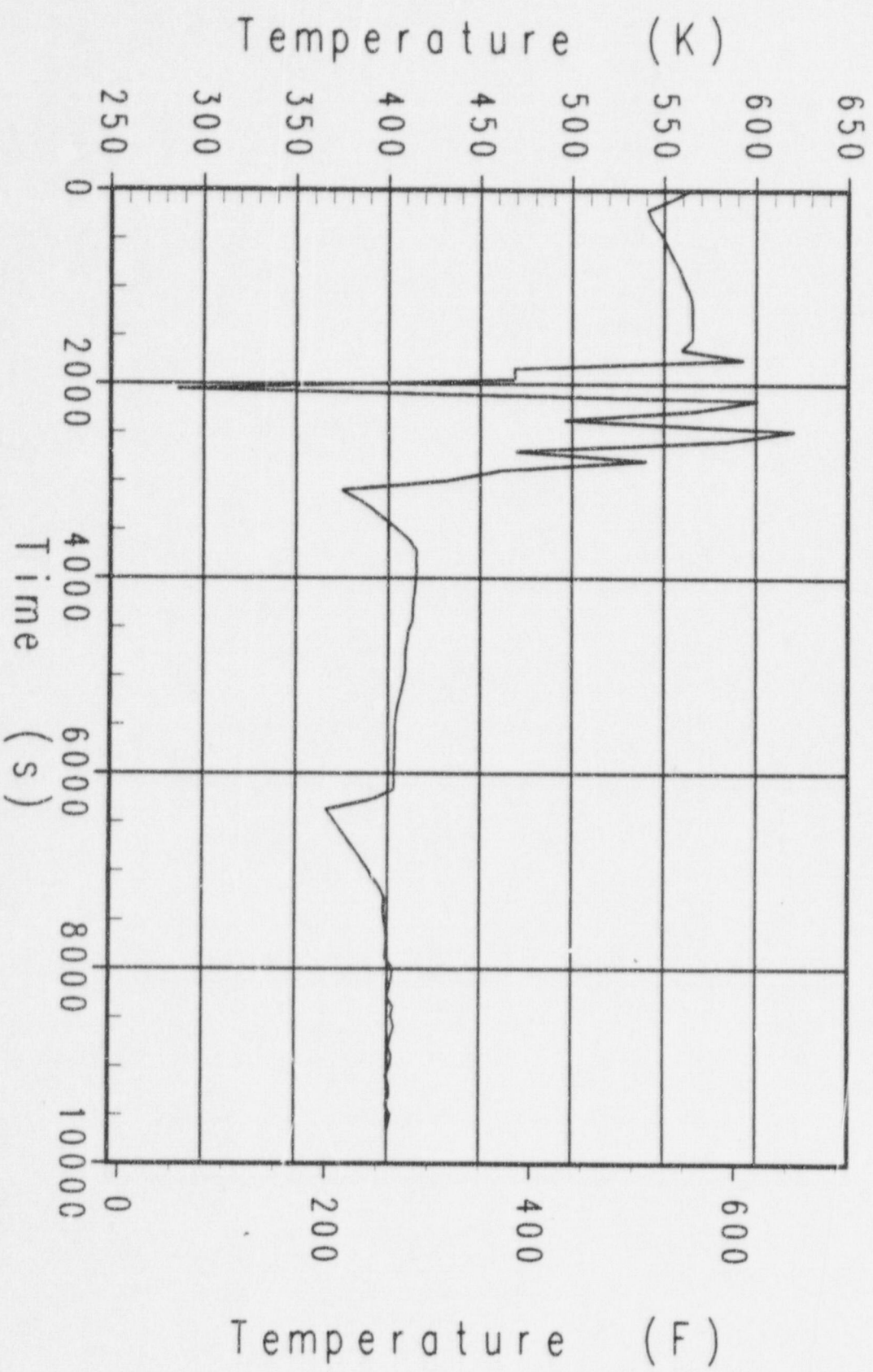

Case x4d3 AP600 Success Criteria MAAP4 Analysis
Core Water Temperature

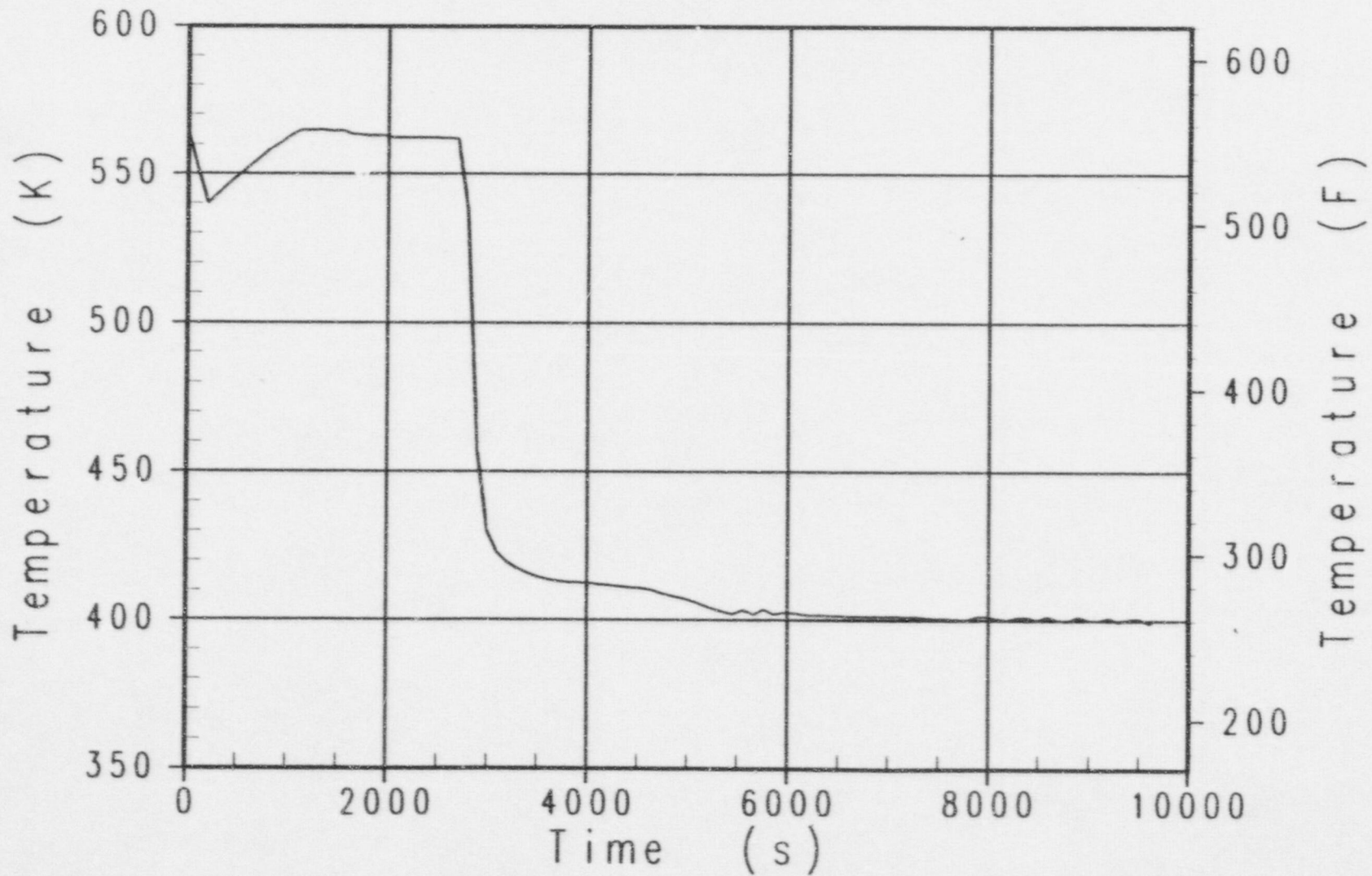

Case x4d3 AP600 Success Criteria MAAP4 Analysis
RPV Downcomer Water Temperature

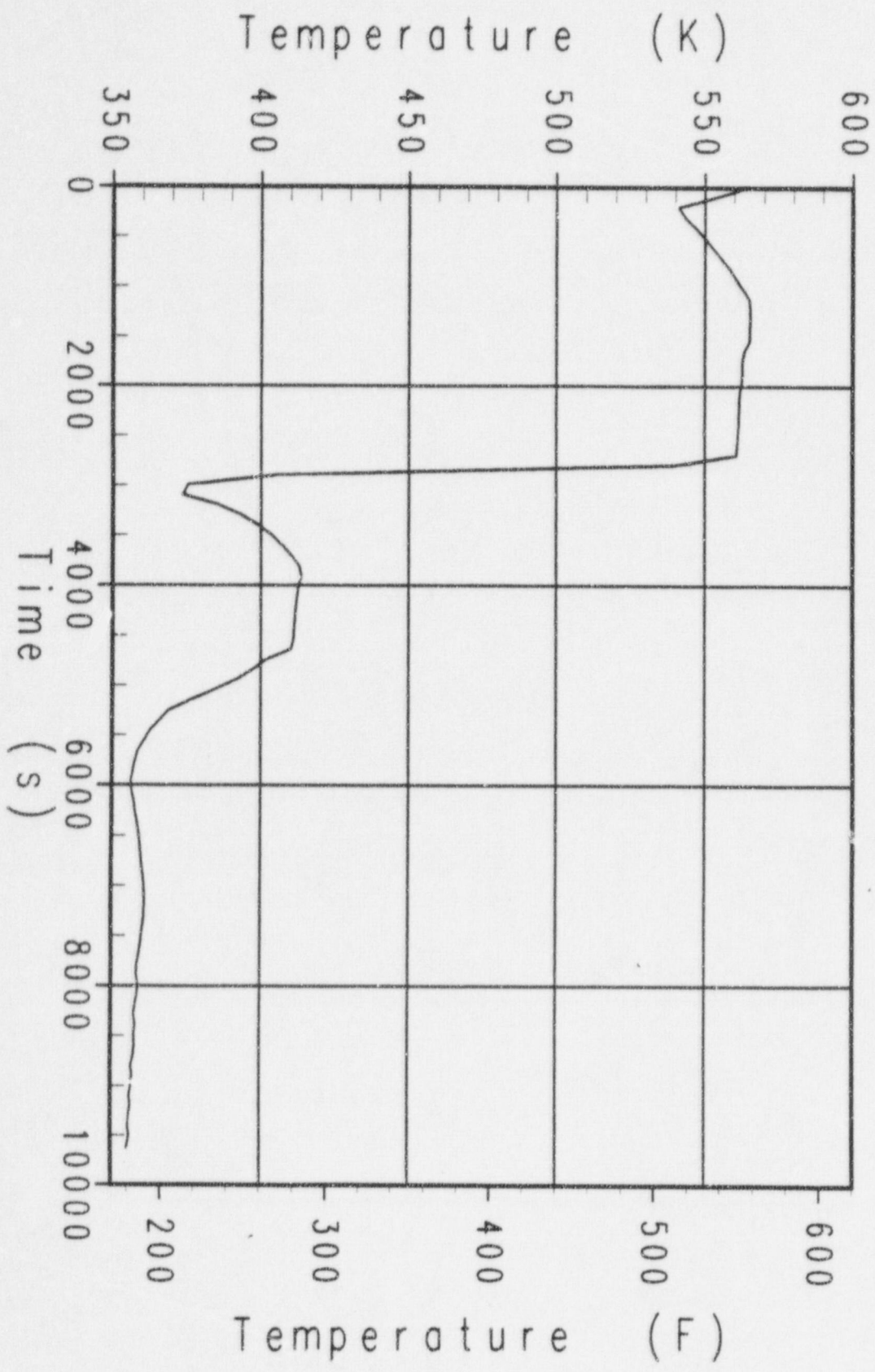

Case x4d3 AP600 Success Criteria MAAP4 Analysis
IRWST Water Temperature

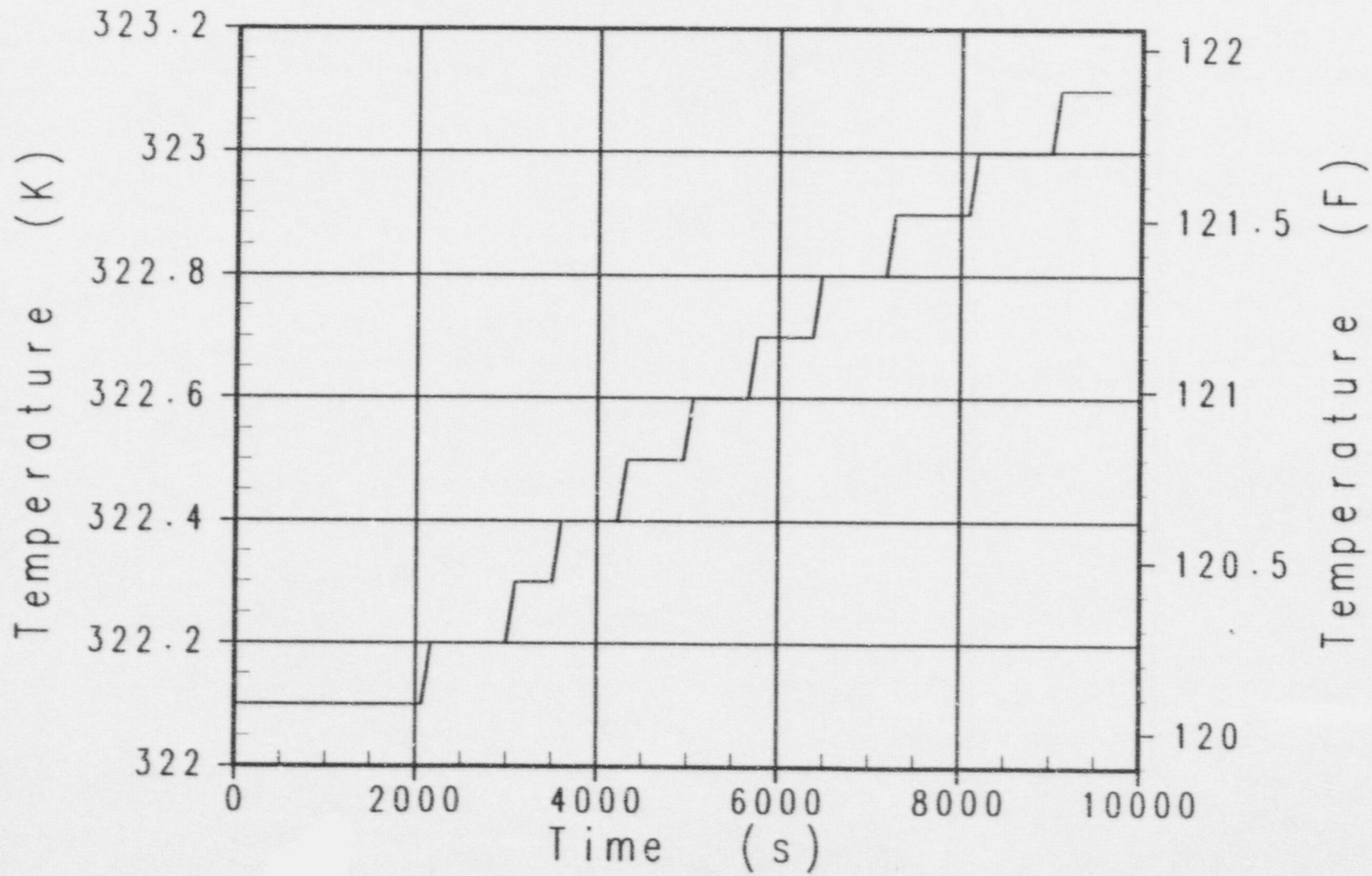

Case x4d3 AP600 Success Criteria MAAP4 Analysis
Accumulator and NRHR Injection Flowrate

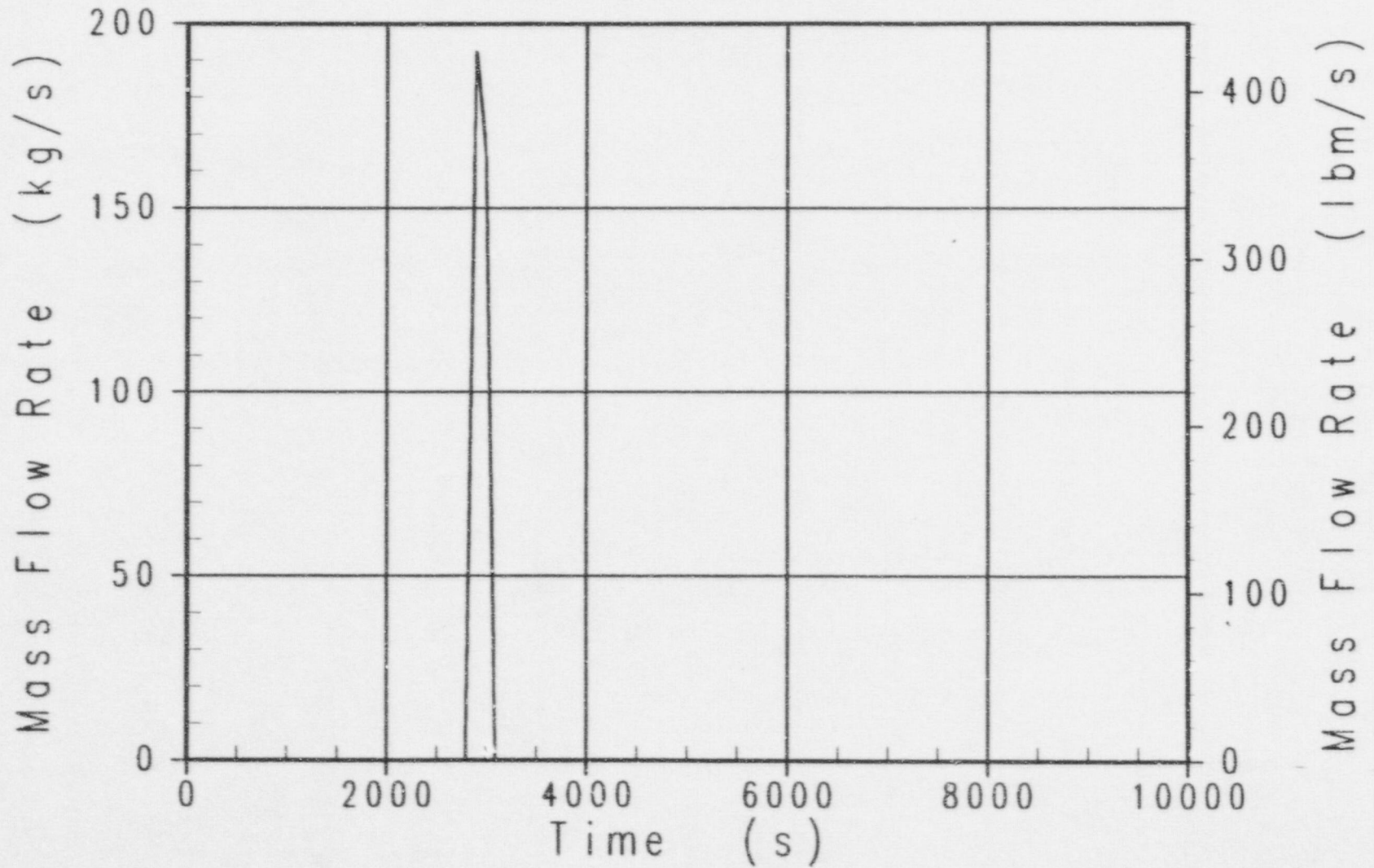

Case x4d3 AP600 Success Criteria MAAP4 Analysis
RCS Break Gas Flowrate

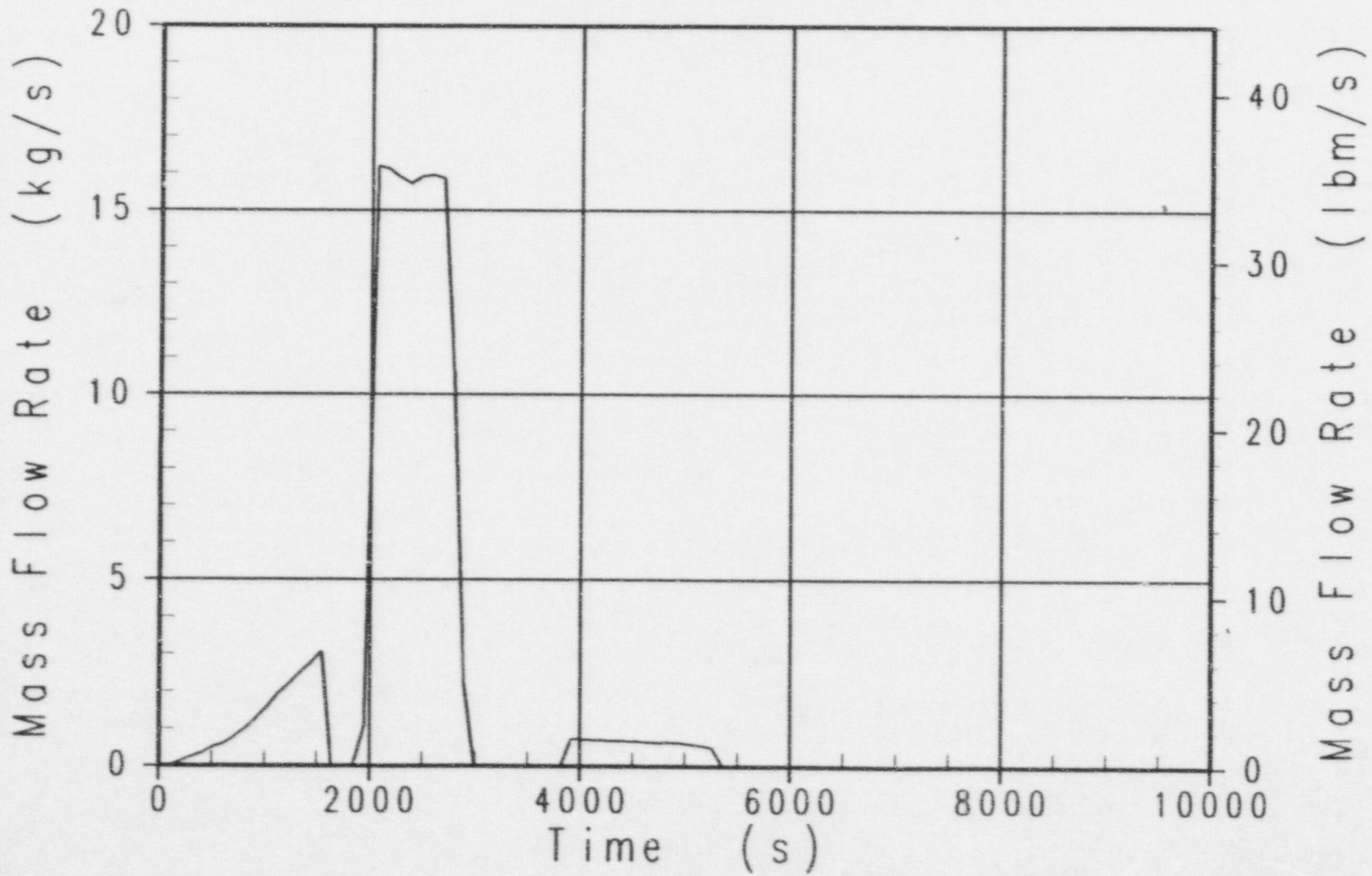

Case x4d3 AP600 Success Criteria MAAP4 Analysis
ADS Stage 4 Gas Flowrate

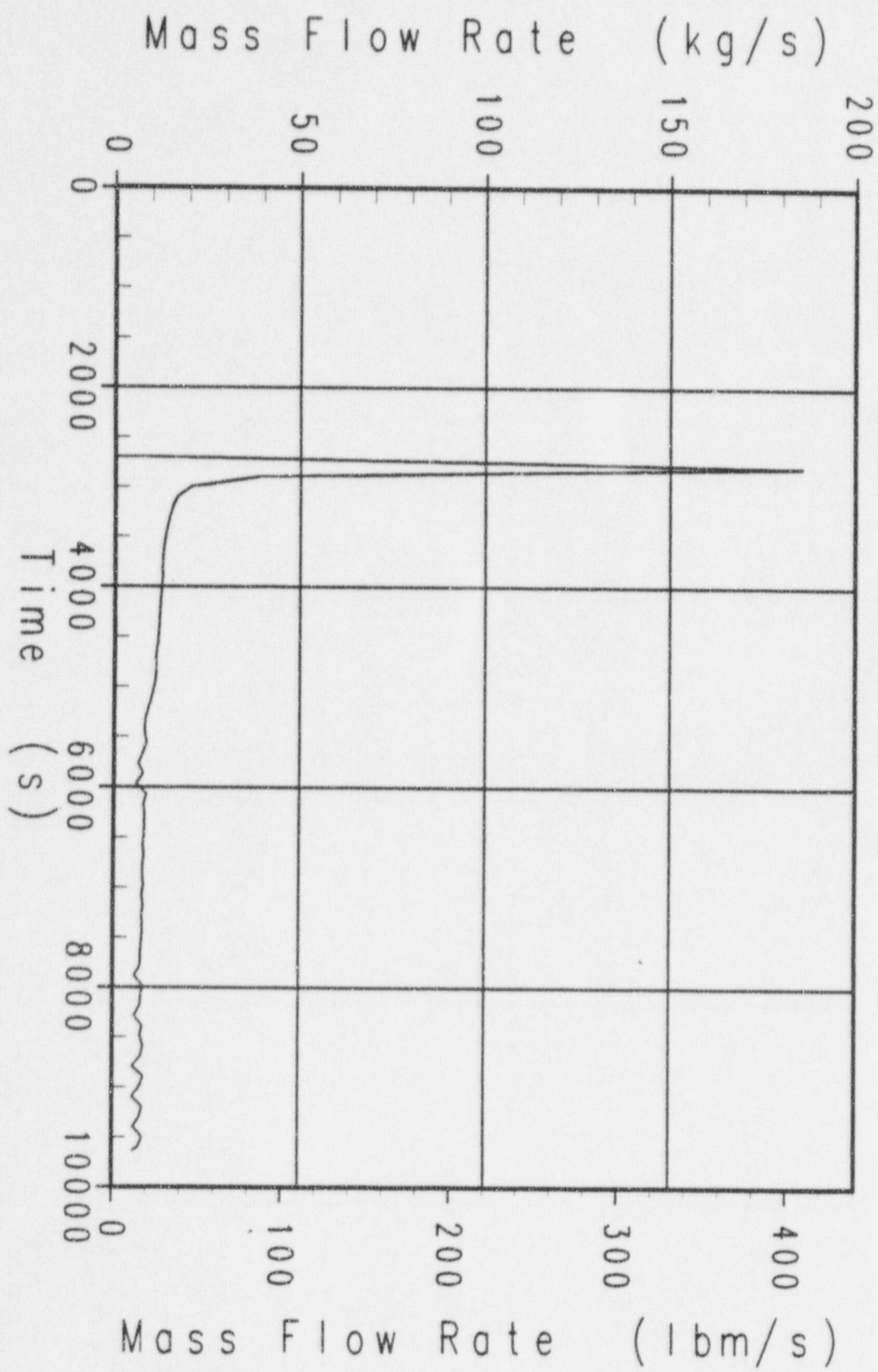

Case x4d3 AP600 Success Criteria MAAP4 Analysis
Safety Valve and ADS Stages 1-3 Gas Flowrate

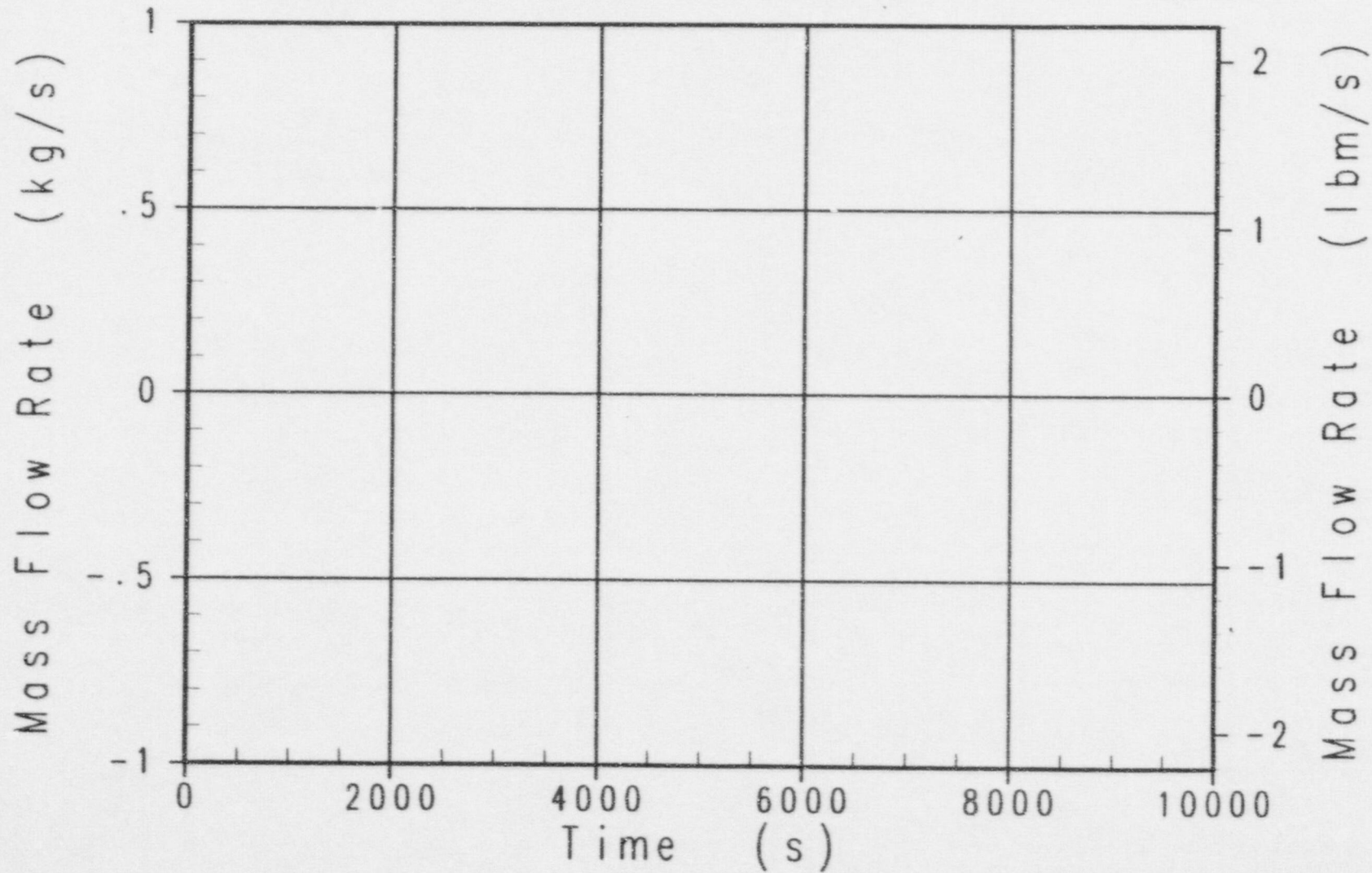

Case x4d3 AP600 Success Criteria MAAp4 Analysis
RCS Break Liquid Flowrate

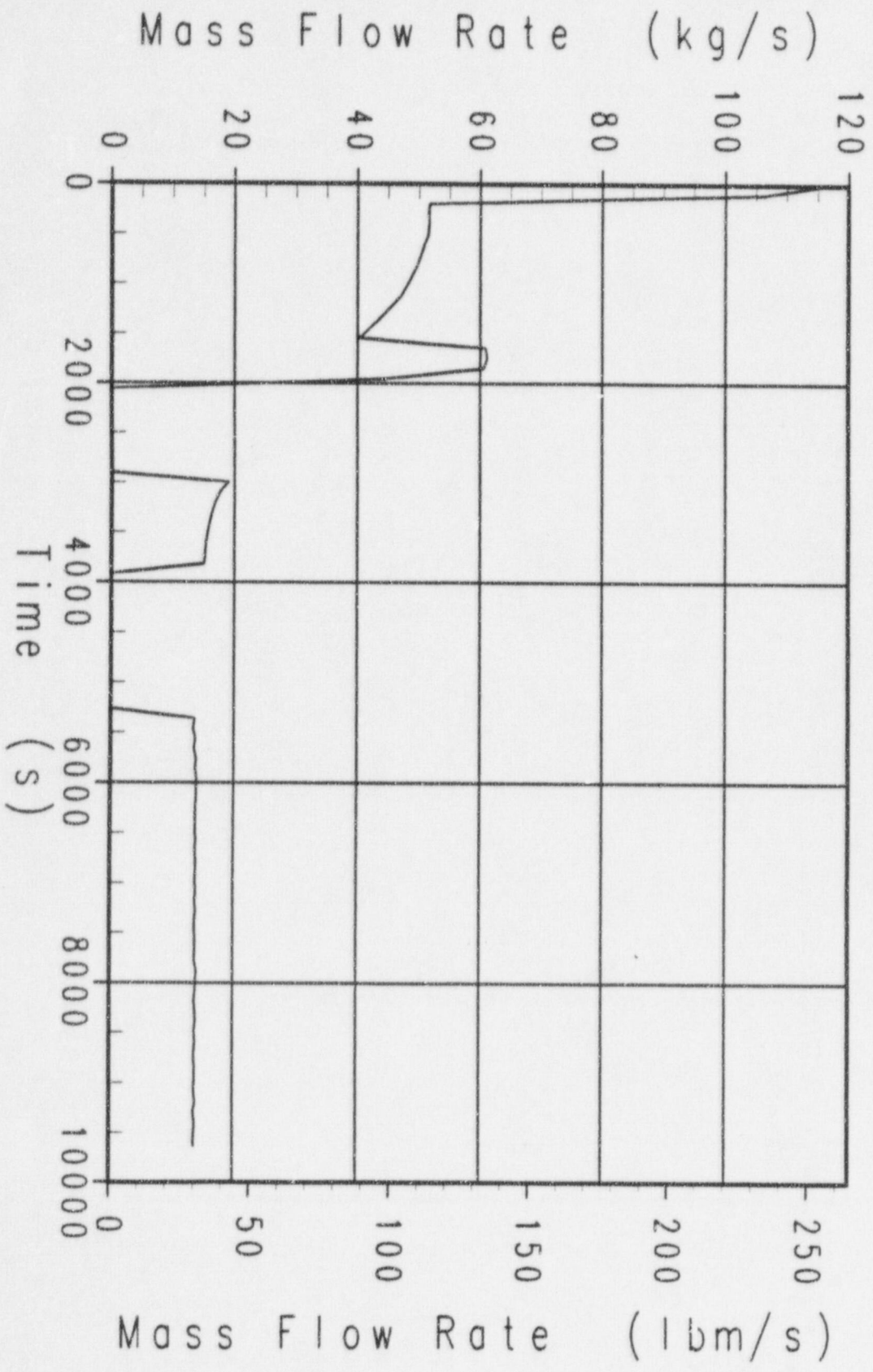

Case x4d3 AP600 Success Criteria MAAP4 Analysis
ADS Stage 4 Liquid Flowrate

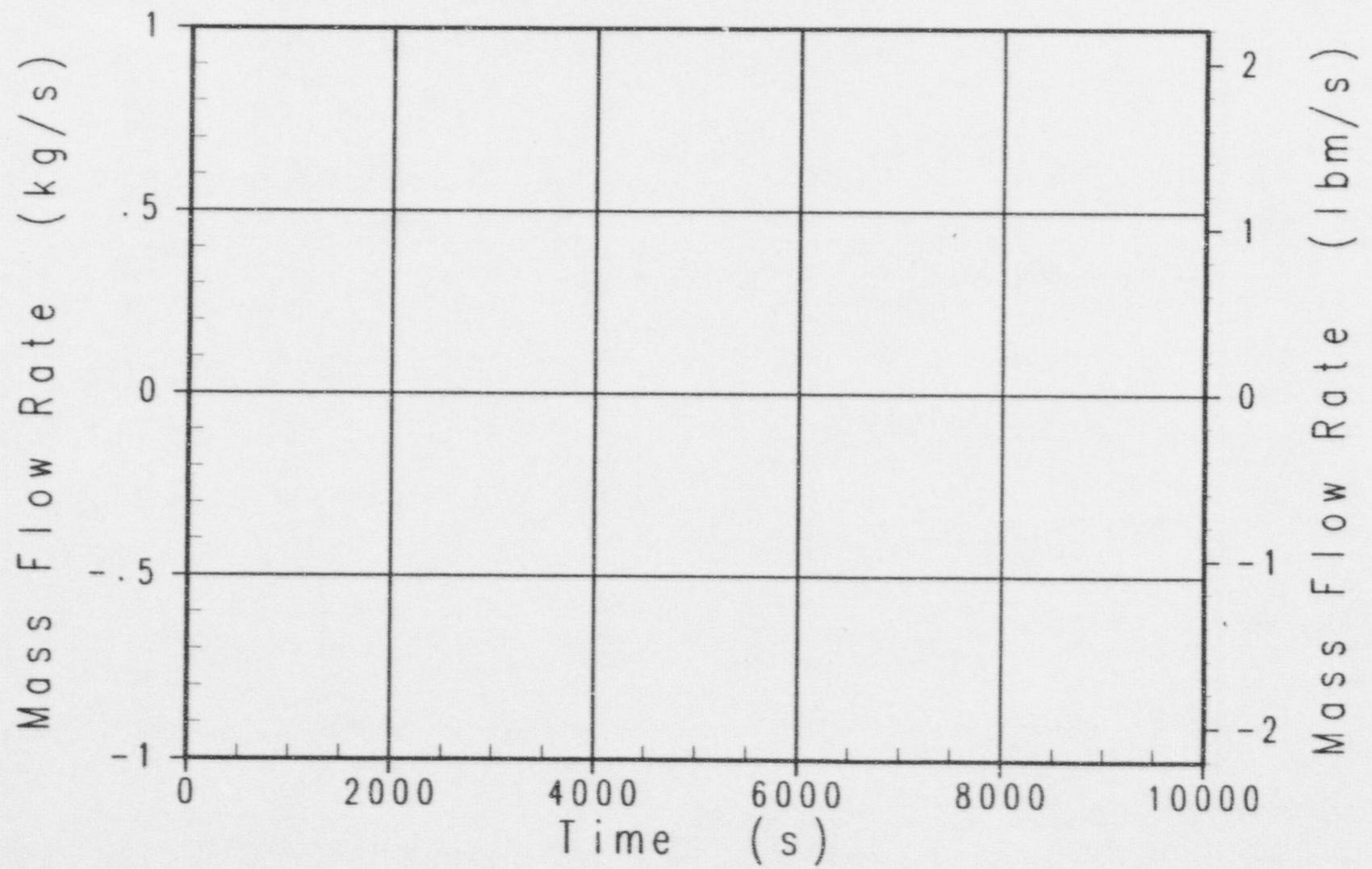

Case x4d3 AP600 Success Criteria MAMP4 Analysis
IRWST Injection Flowrate (neg. means into RCS)

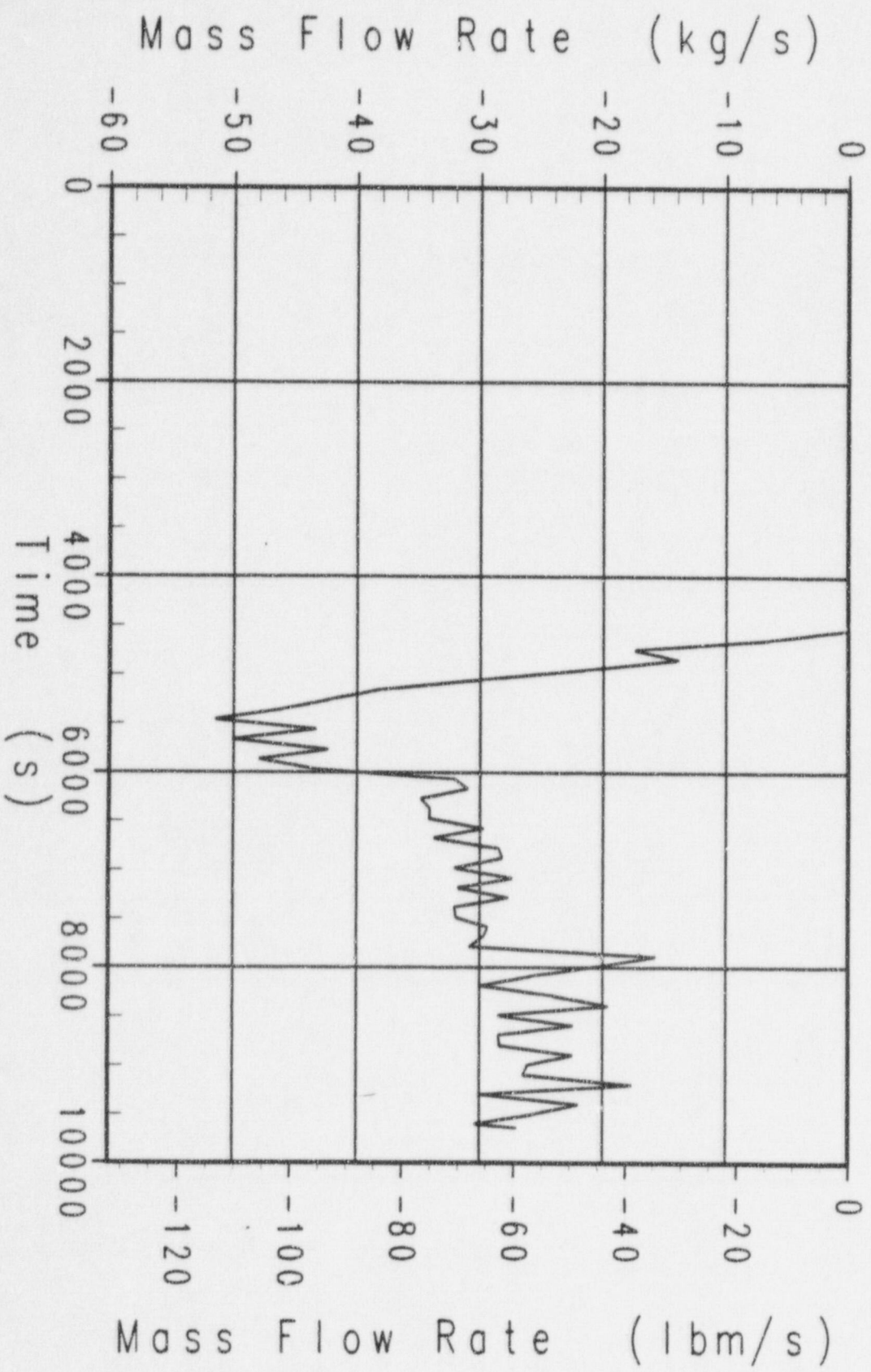

Case x4d3 AP600 Success Criteria MAAP4 Analysis
CMT-1 Injection Flowrate

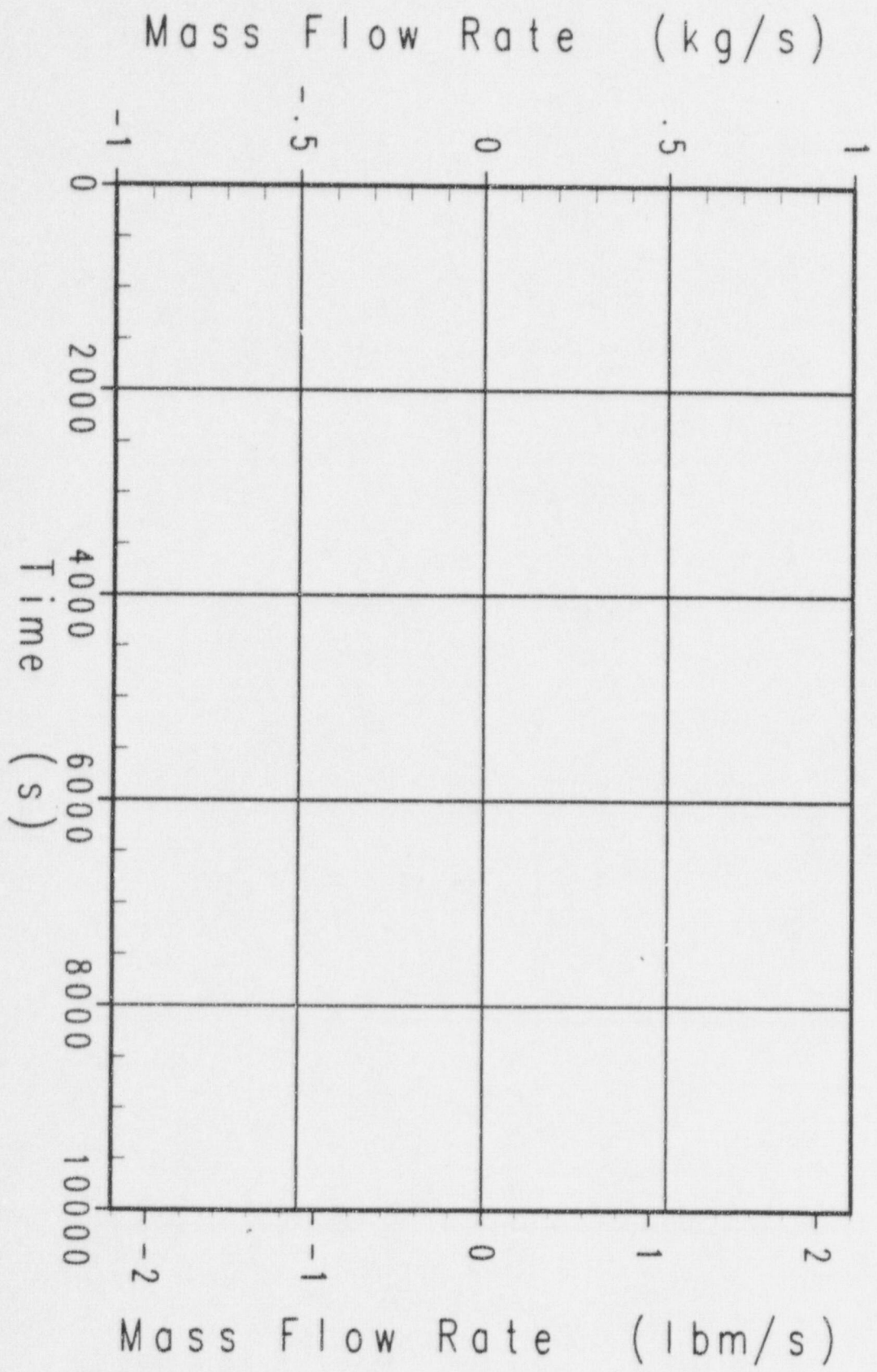

Case x4d3 AP600 Success Criteria MAAP4 Analysis
Safety Valve and ADS Stages 1-3 Liquid Flowrate

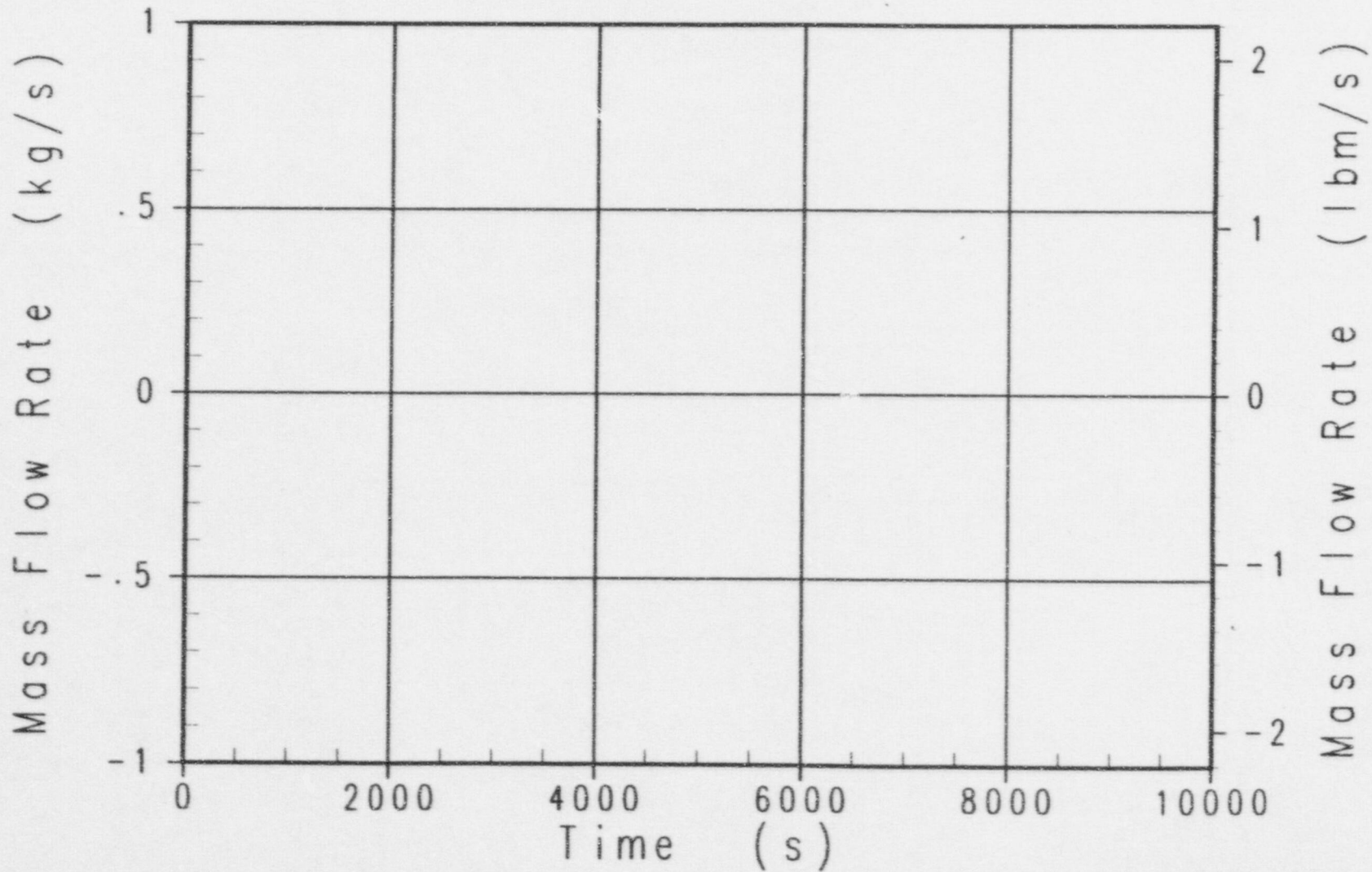

Case x4d3 AP600 Success Criteria MAAP4 Analysis
CMT-1 Water Level

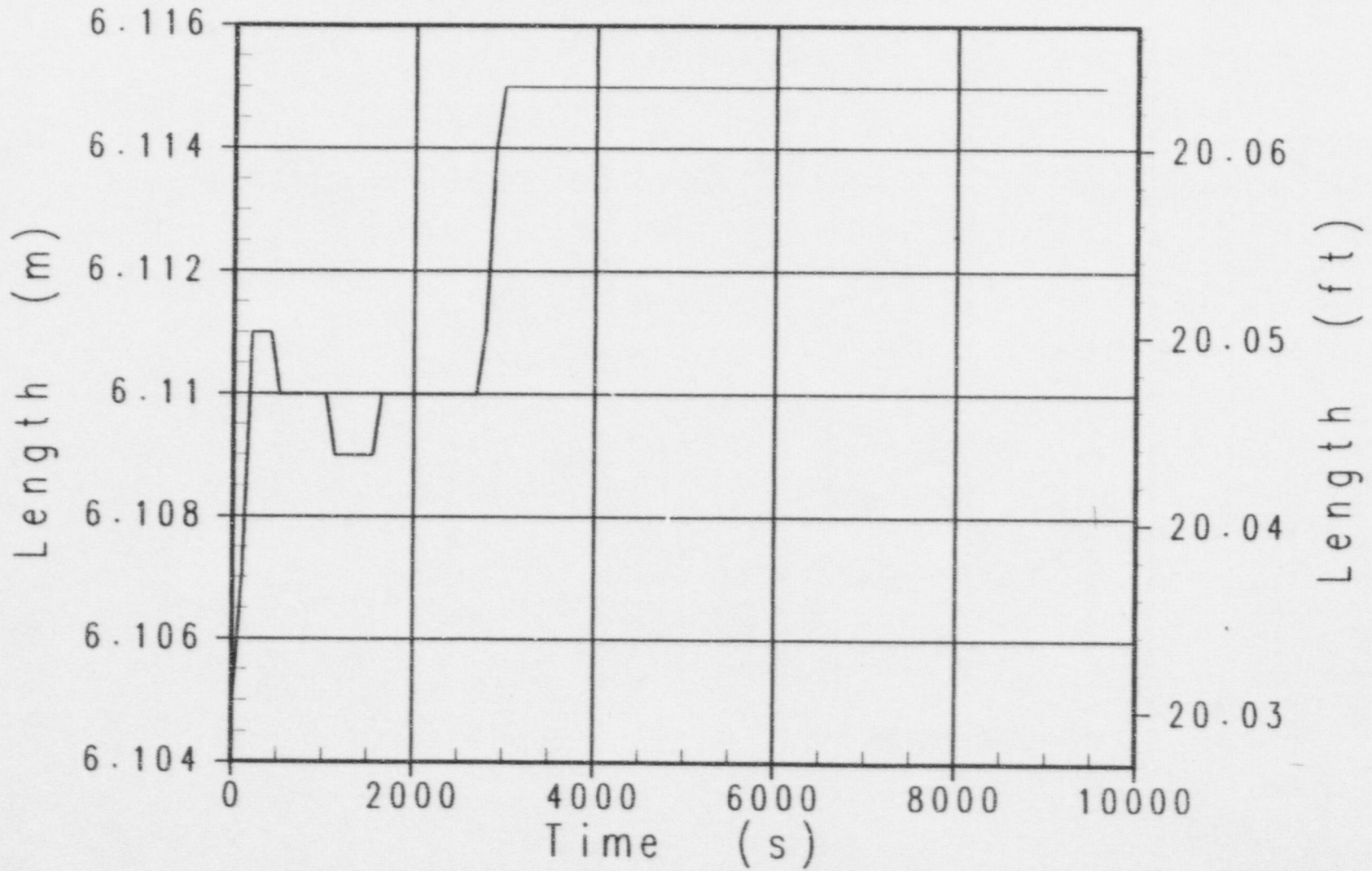

Case x4d3 AP600 Success Criteria MAAP4 Analysis
Pressurizer Water Level (From Pzr Bottom)

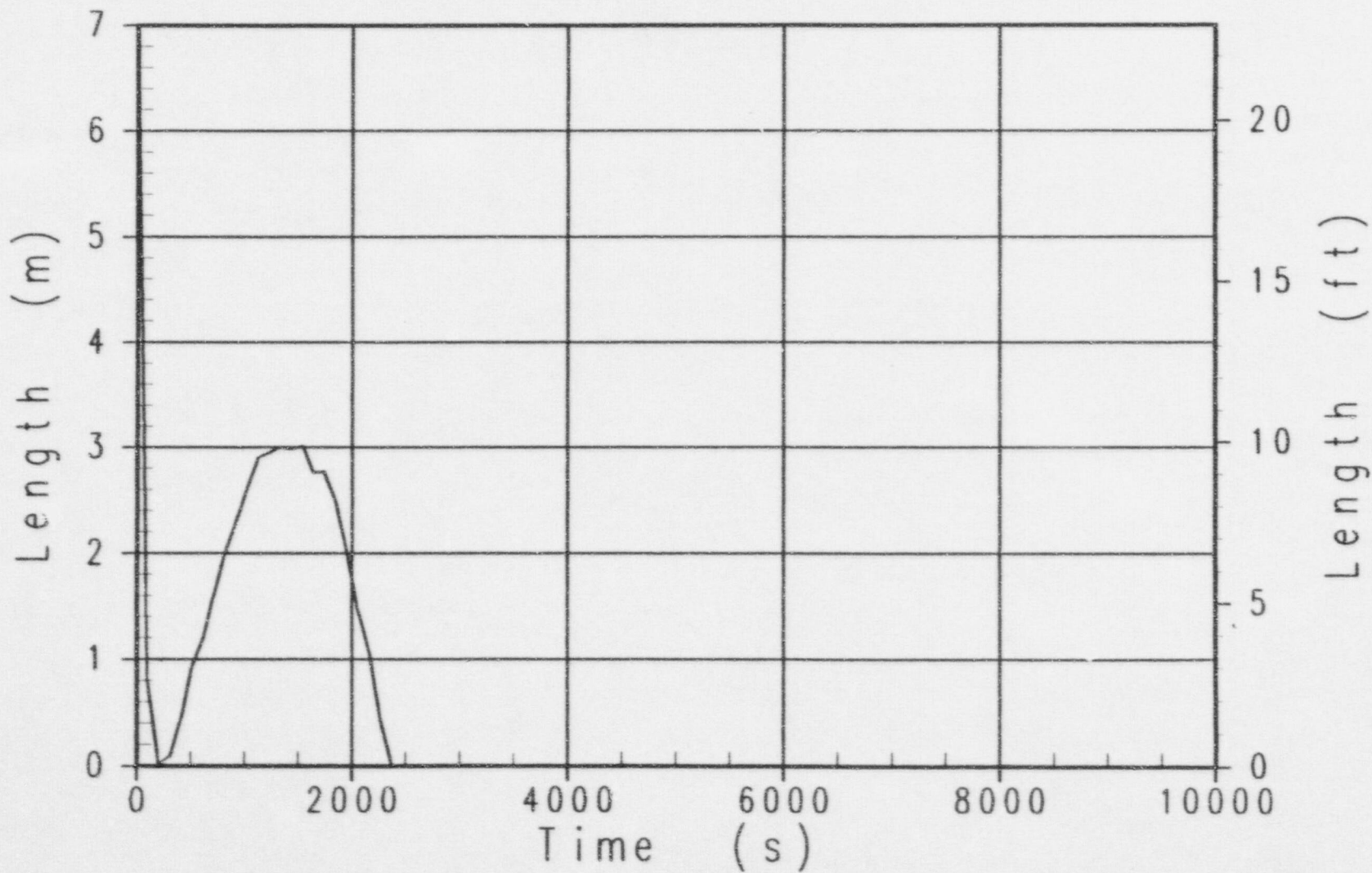

Case s30 AP600 Success Criteria MAAP4 Analysis
Broken Loop Steam Generator Pressure

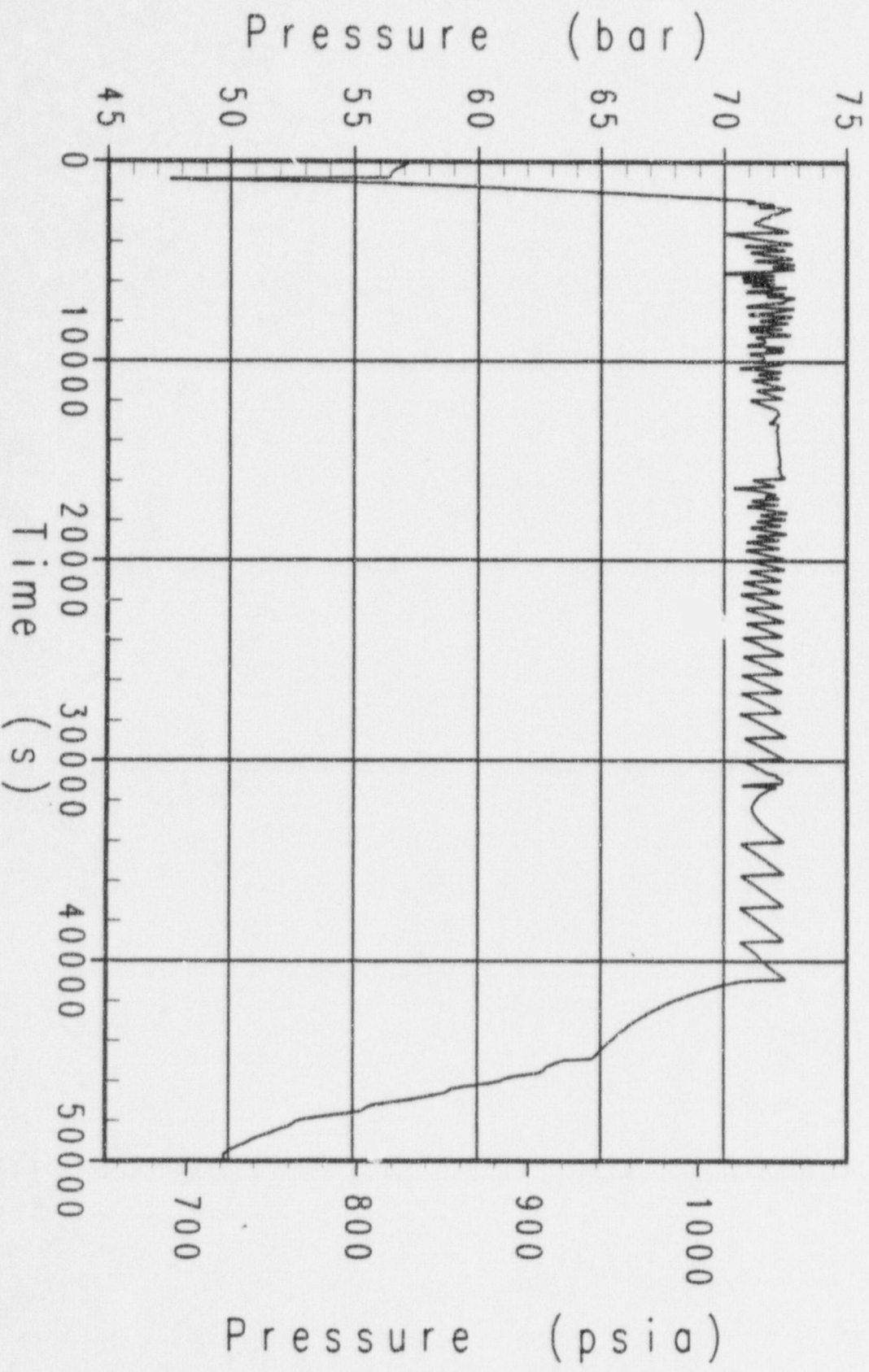

Case 330 AP600 Success Criteria MAAP4 Analysis
Primary System Pressure

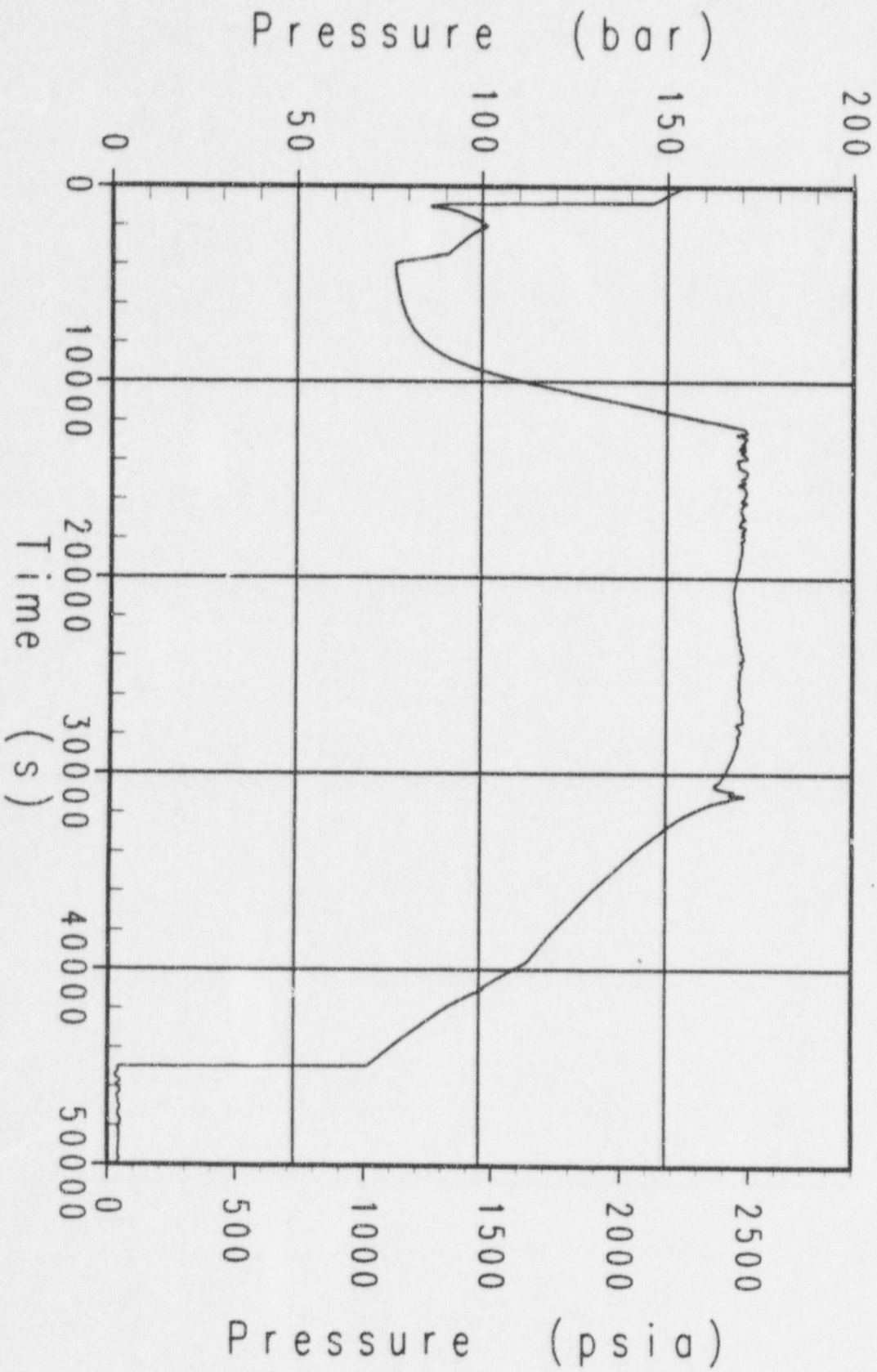

Case s3a AP600 Success Criteria MAAP4 Analysis
Containment Pressure

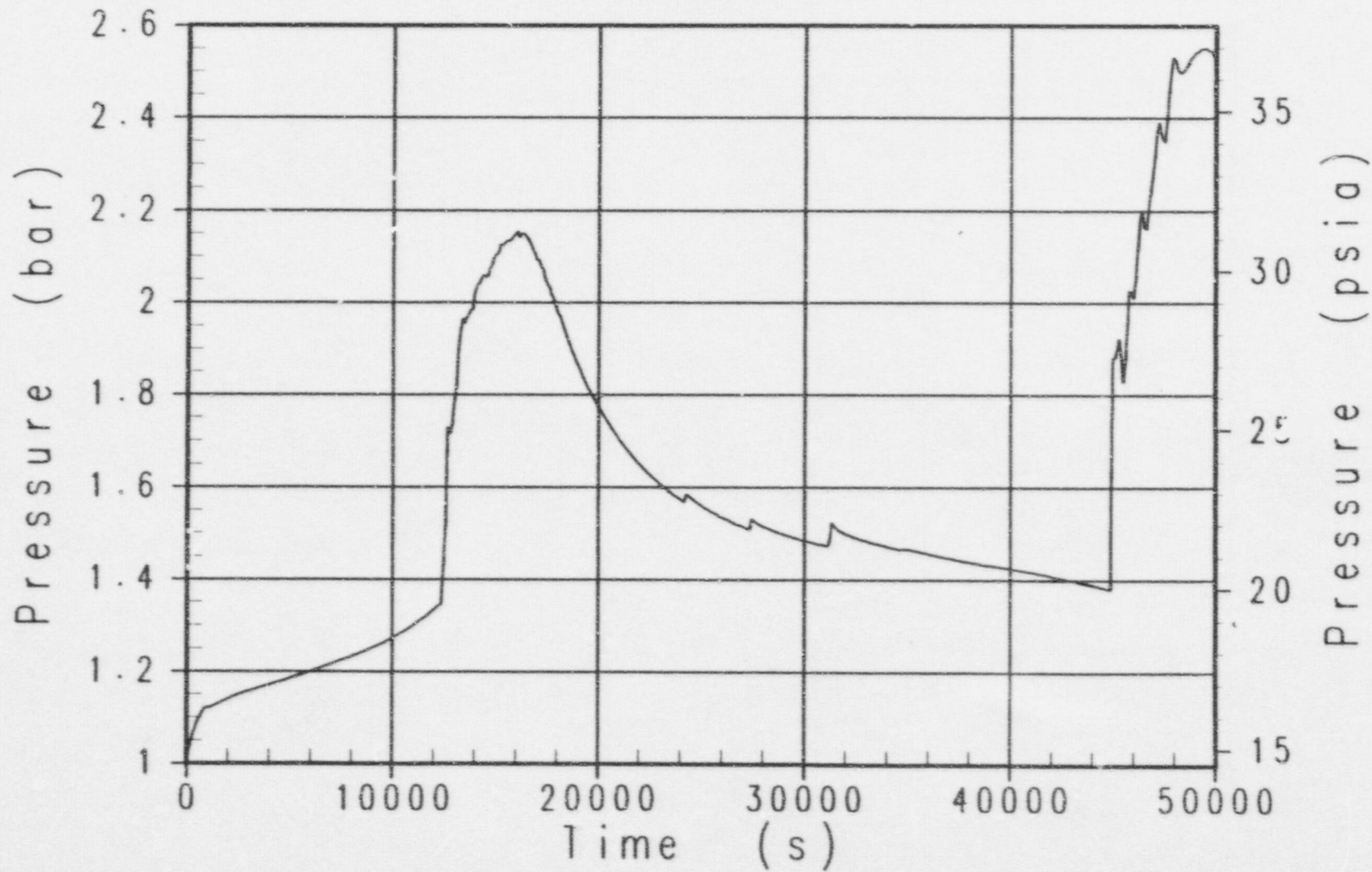

Case s3a AP600 Success Criteria MAPP4 Analysis
Unbroken Loop Steam Generator Pressure

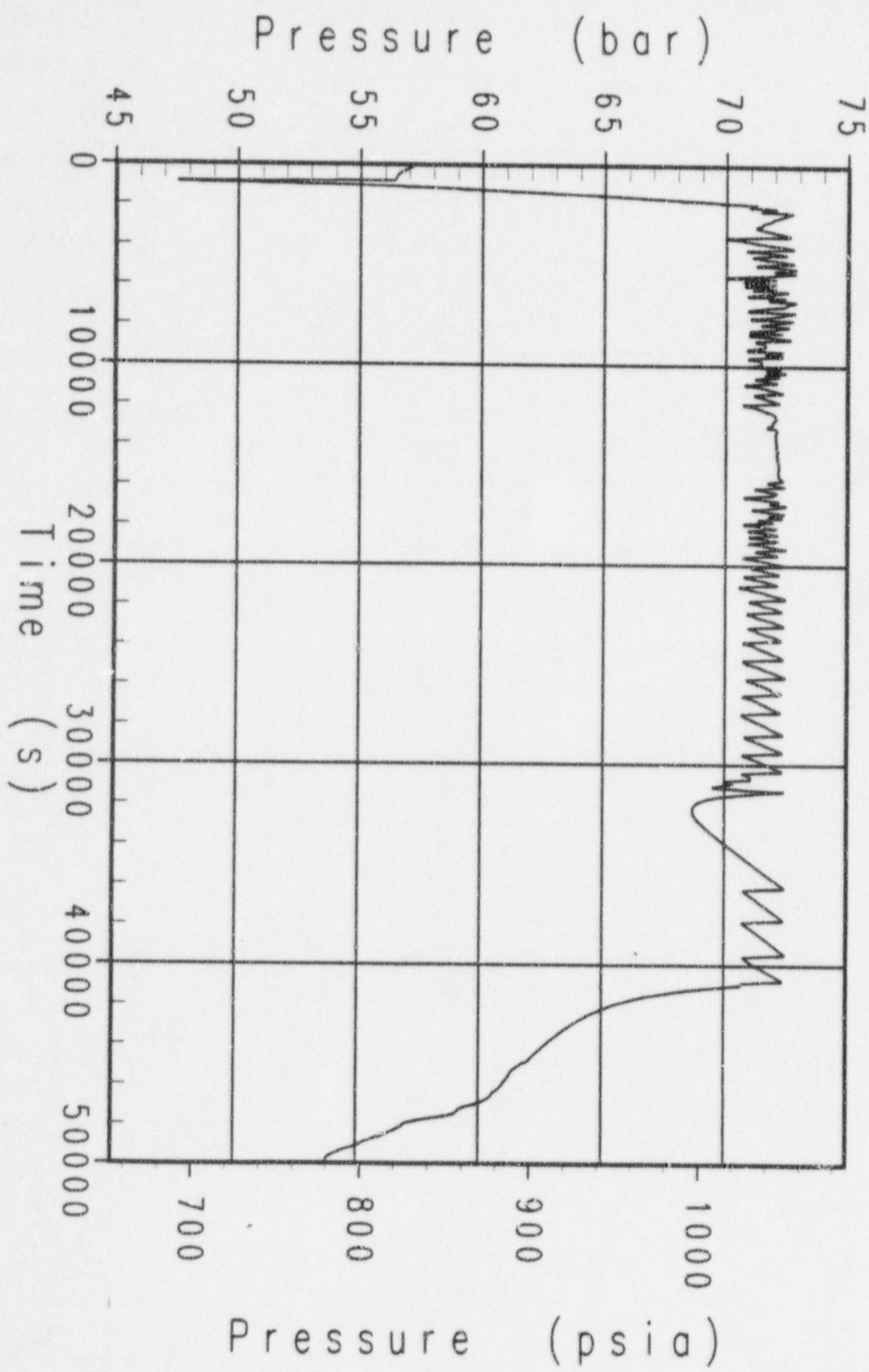

Case s3a AP600 Success Criteria MAAP4 Analysis
Decay Power

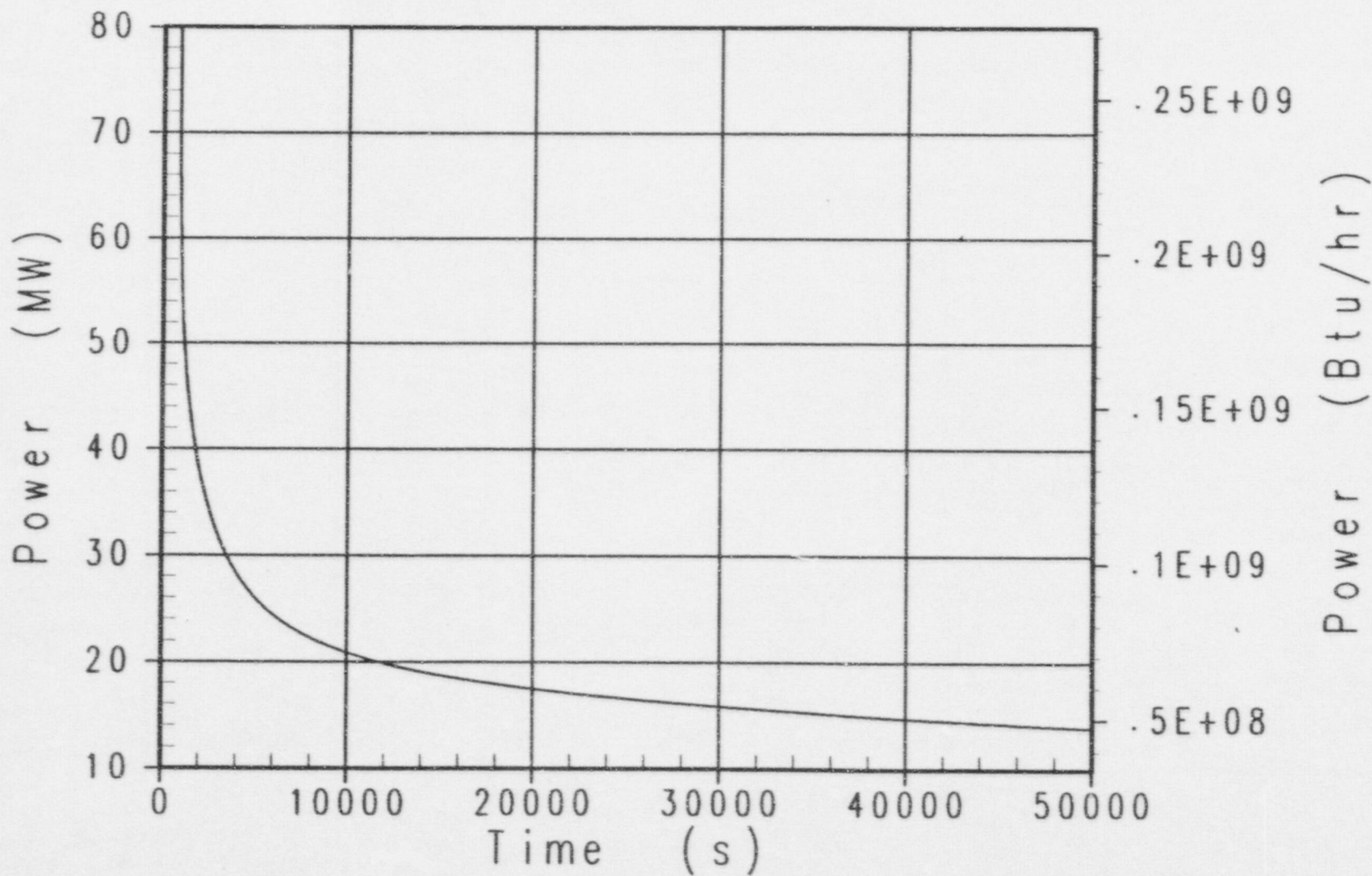

Case s3a AP600 Success Criteria MAAP4 Analysis
PRHR Heat Removal Rate

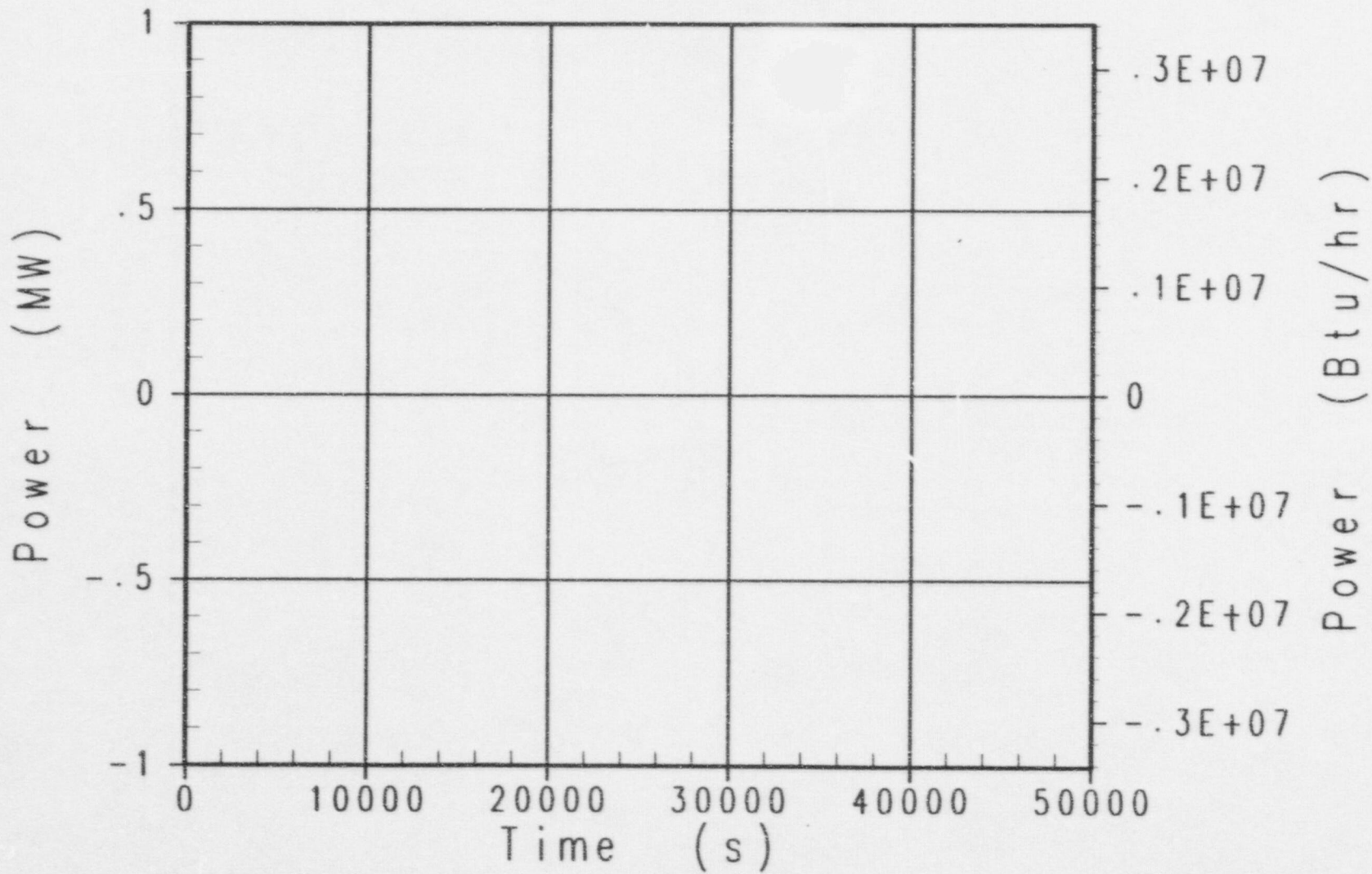

Case s3a AP600 Success Criteria MAAP4 Analysis
Peak Temperature in the Core

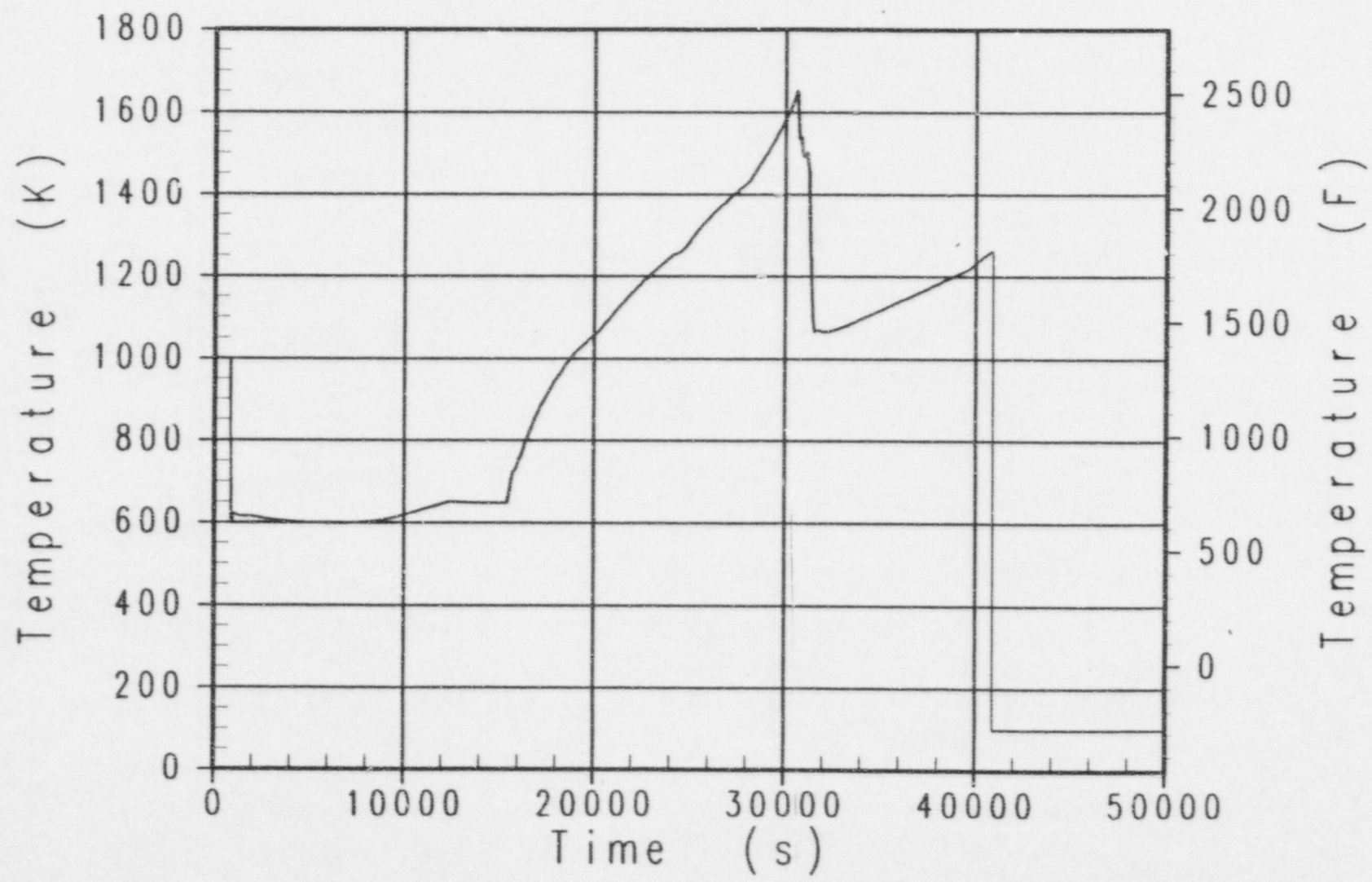

Case s3a AP600 Success Criteria MAAP4 Analysis
Cold Leg Water Temperature



Case s3o AP600 Success Criteria MAAP4 Analysis
Core Water Temperature

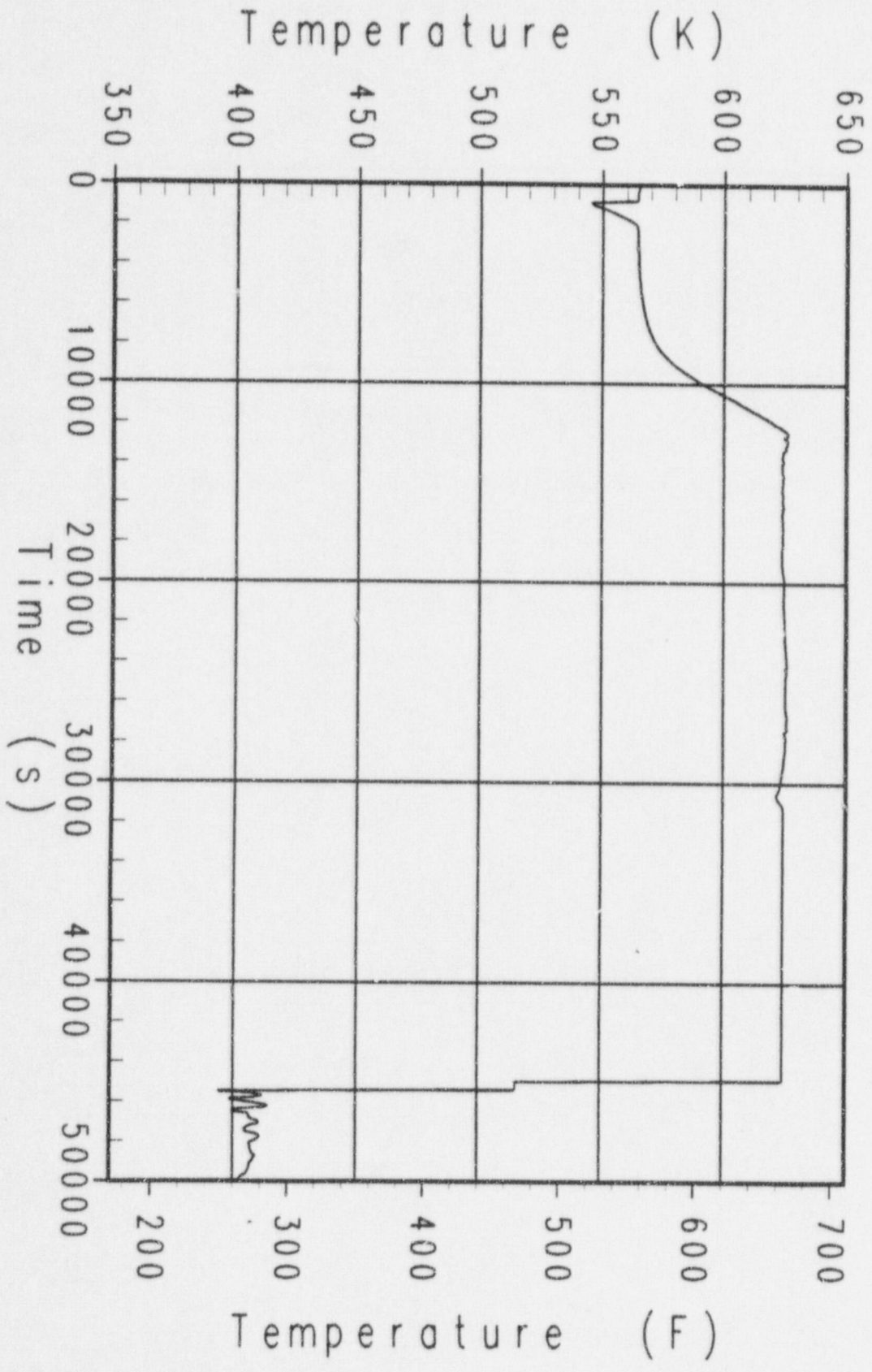

Case s3a AP600 Success Criteria MAAP4 Analysis
RPV Downcomer Water Temperature

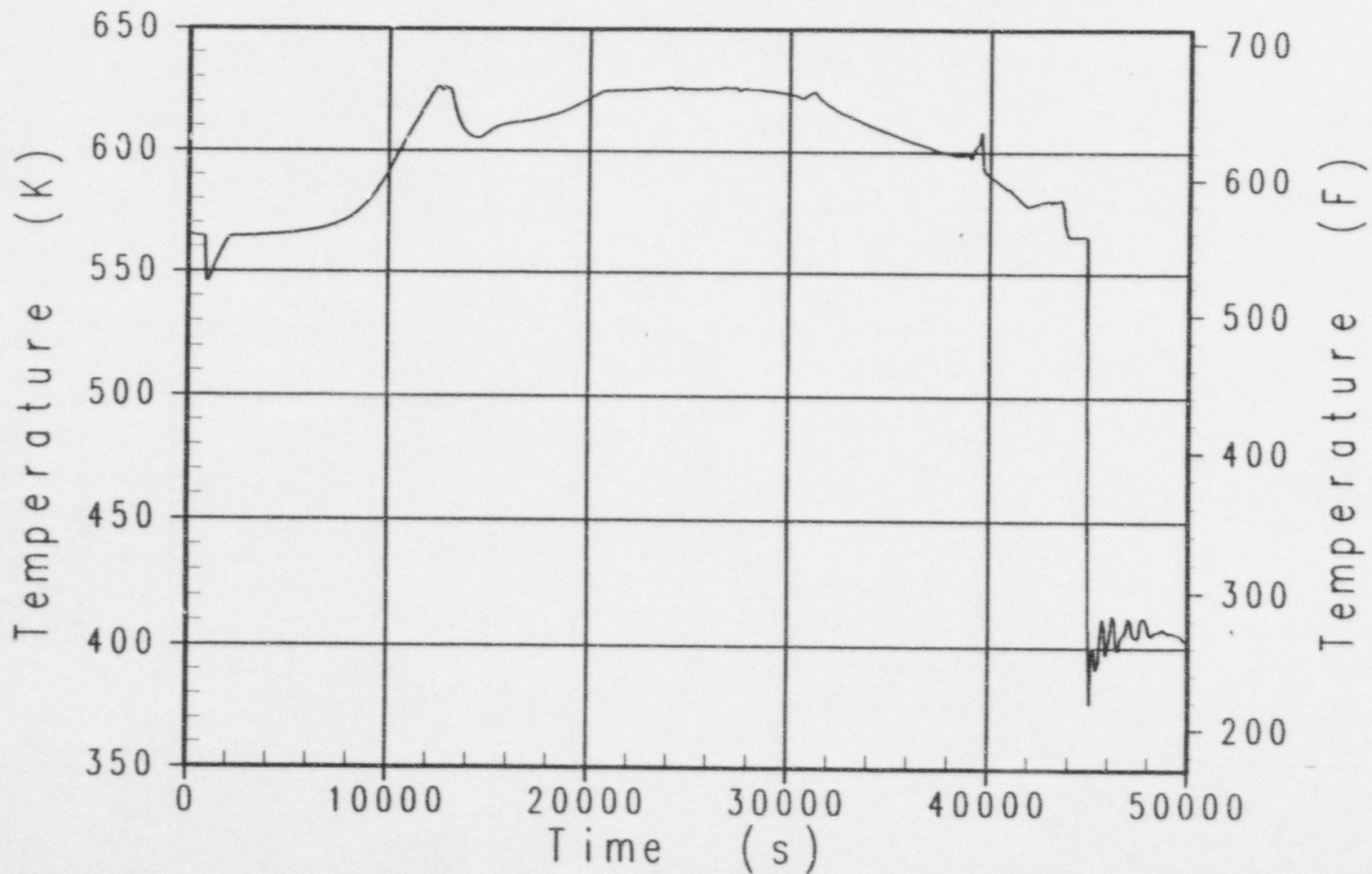

Case s3a AP600 Success Criteria MAAP4 Analysis
IRWST Water Temperature

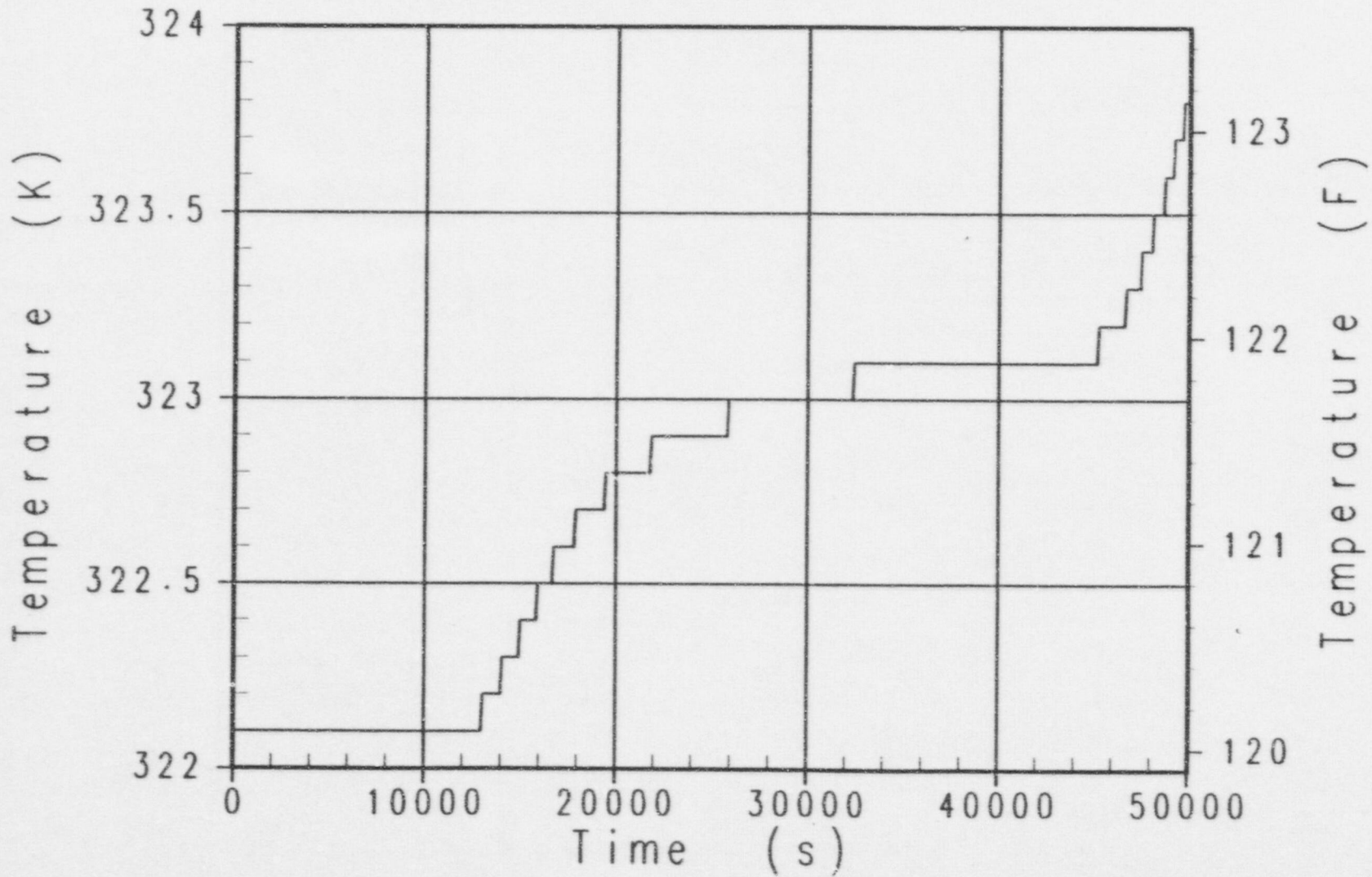

Case s3o AP600 Success Criteria MAAP4 Analysis
Accumulator and NRHR Injection Flowrate

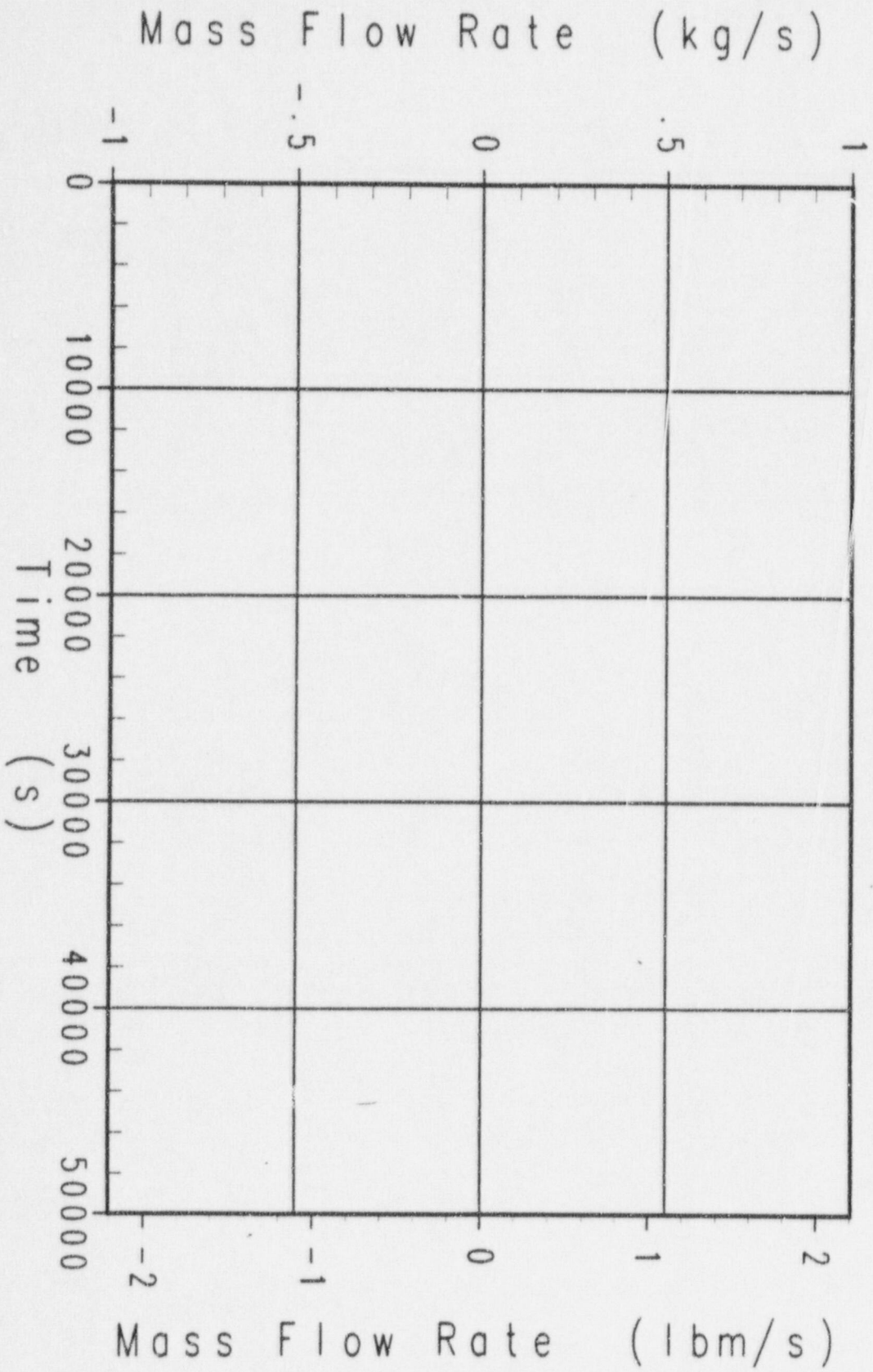

Case s3a AP600 Success Criteria MAAP4 Analysis
RCS Break Gas Flowrate

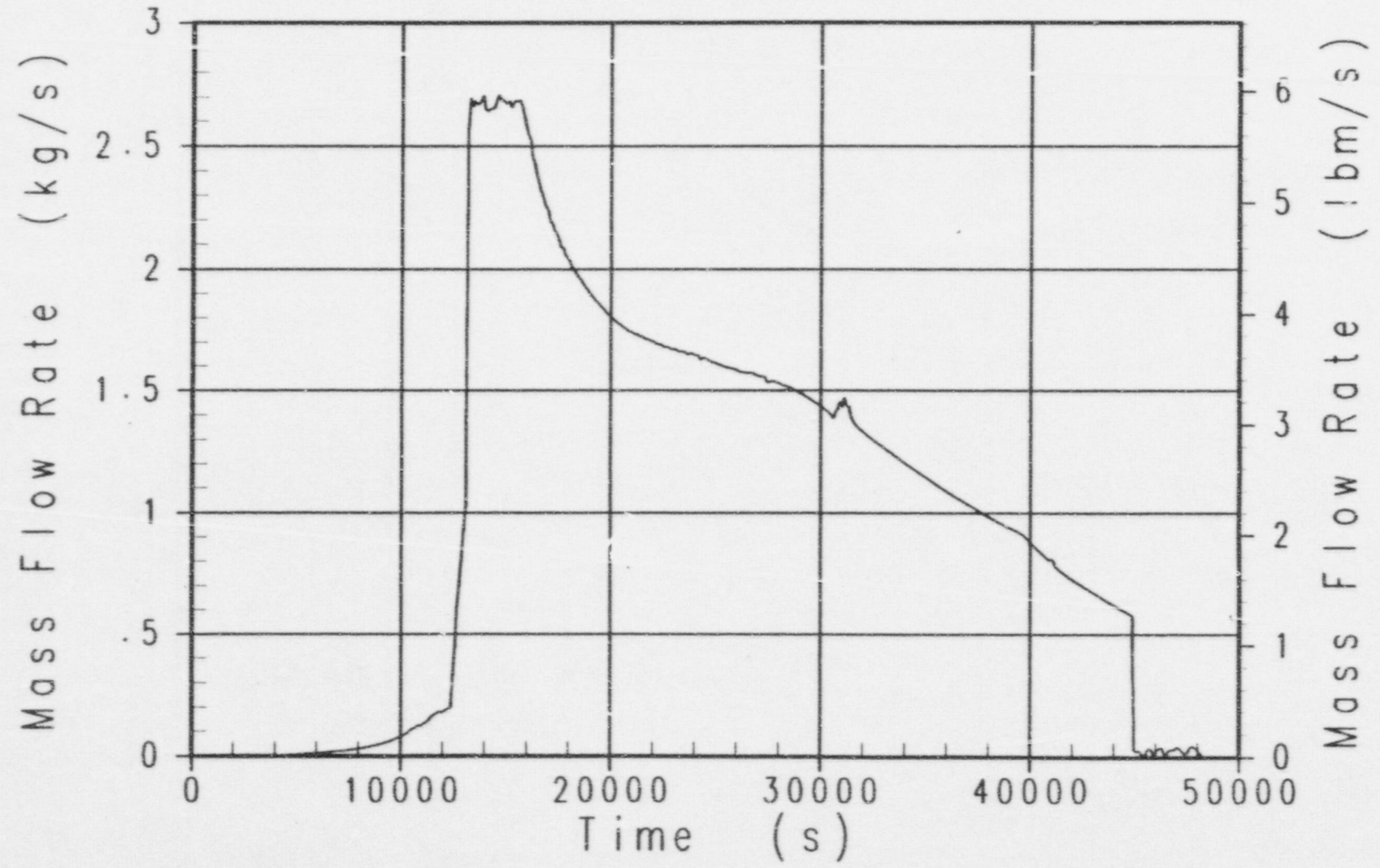

Case s3a AP600 Success Criteria MAAp4 Analysis
ADS Stage 4 Gas Flowrate

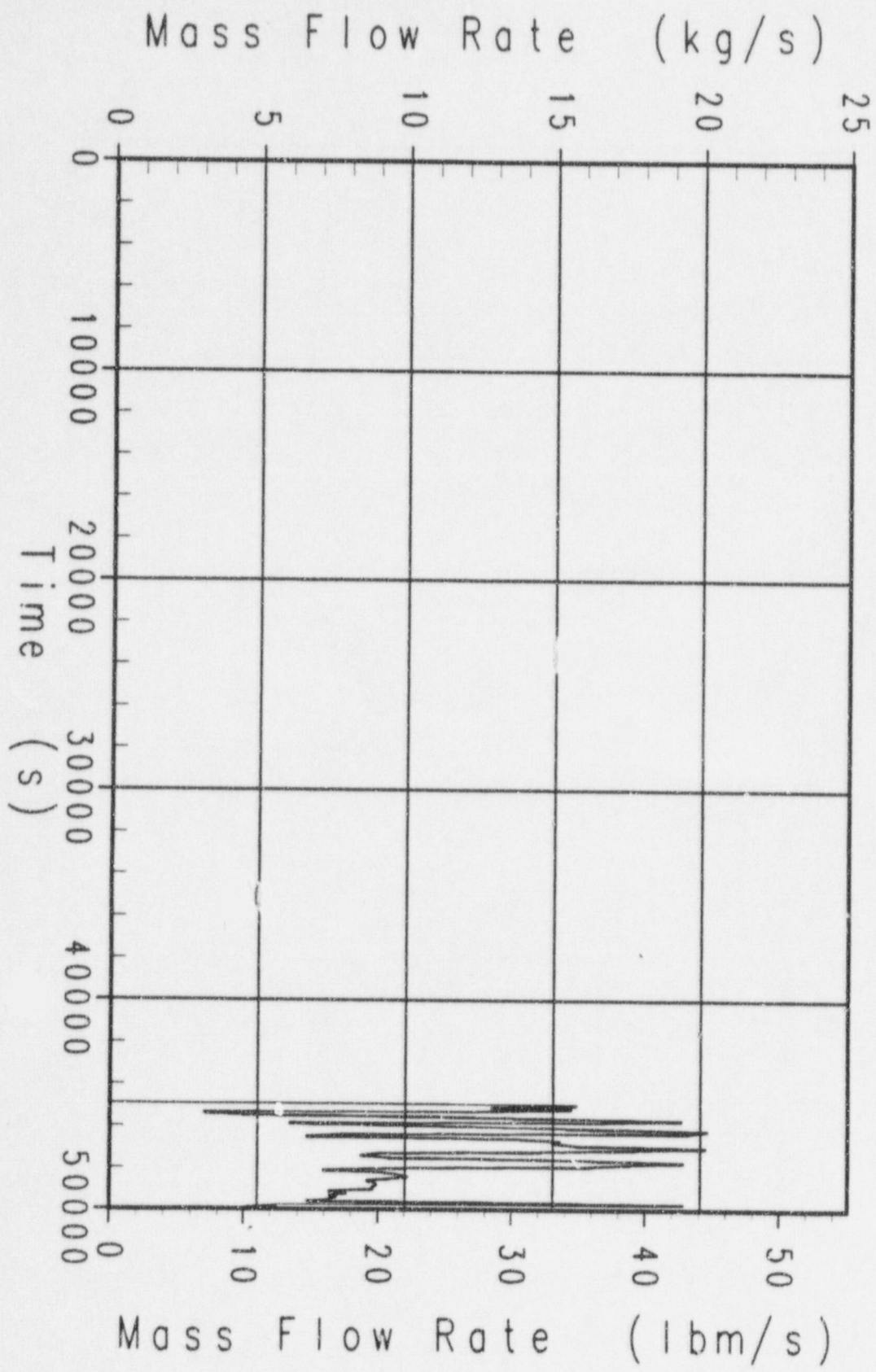

Case s3a AP600 Success Criteria MAAP4 Analysis
Safety Valve and ADS Stages 1-3 Gas Flowrate

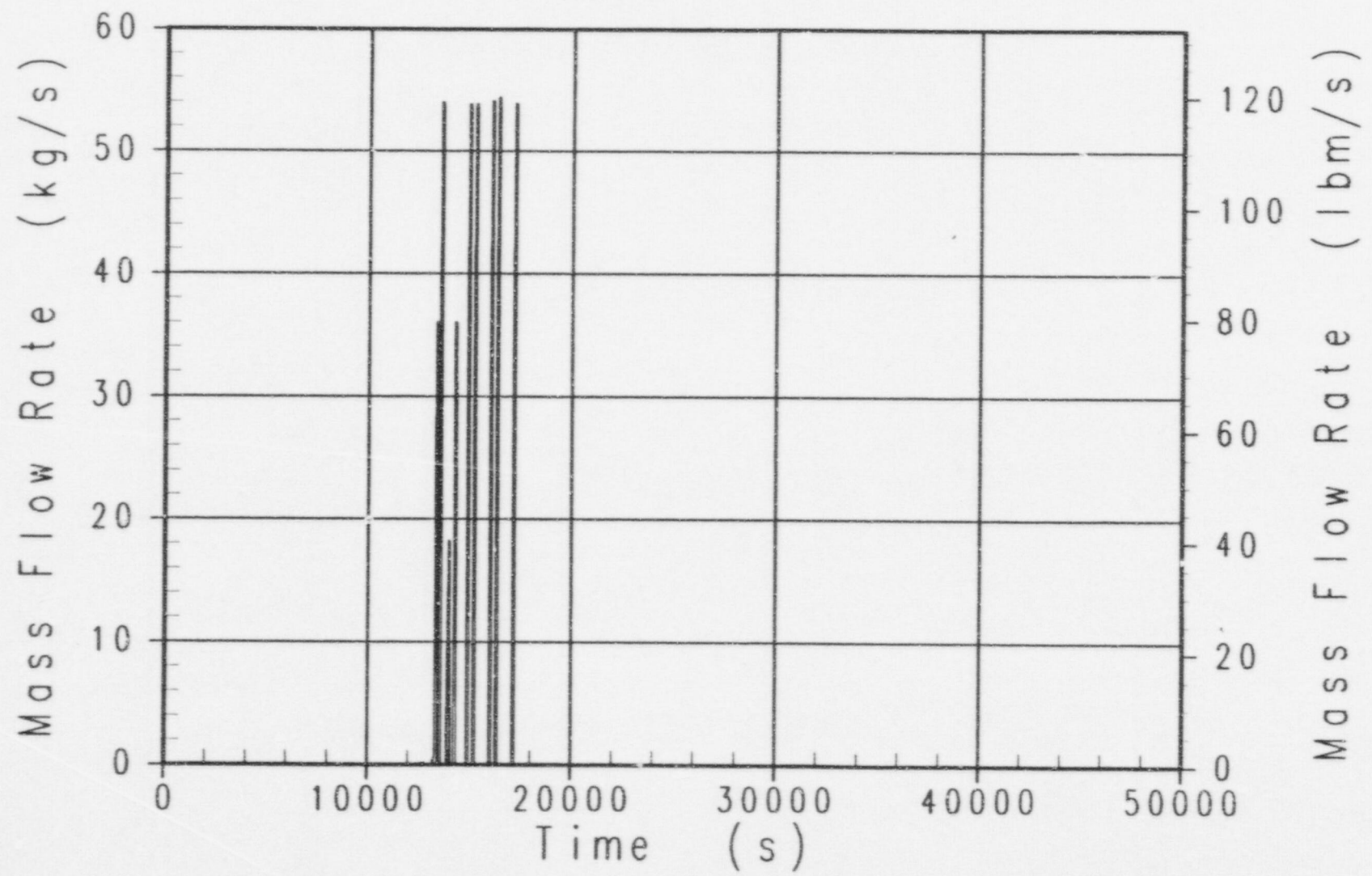

Case s3a AP600 Success Criteria MAAP4 Analysis
RCS Break Liquid Flowrate

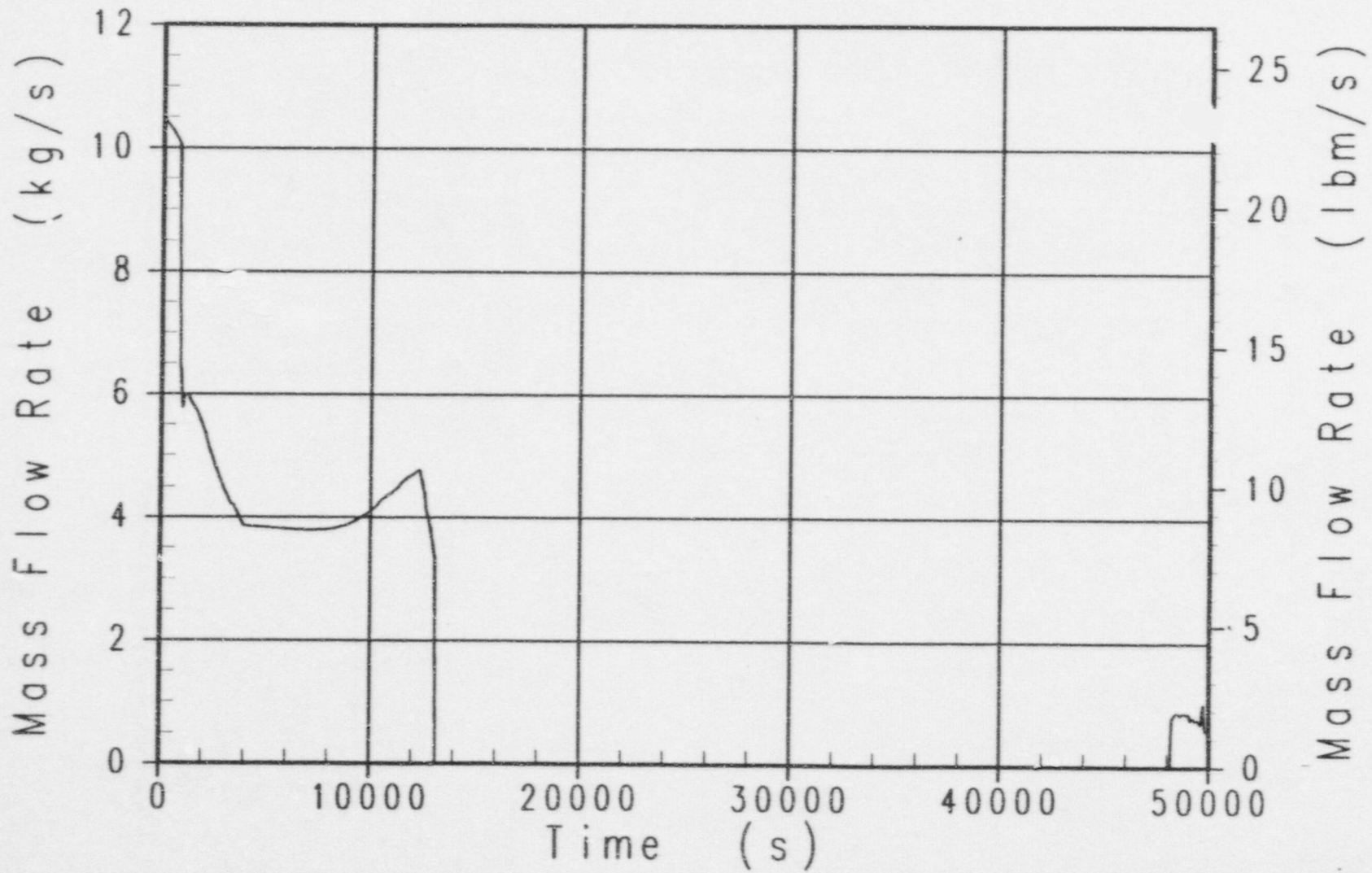

Case s3a AP600 Success Criteria MAAP4 Analysis
ADS Stage 4 Liquid Flowrate

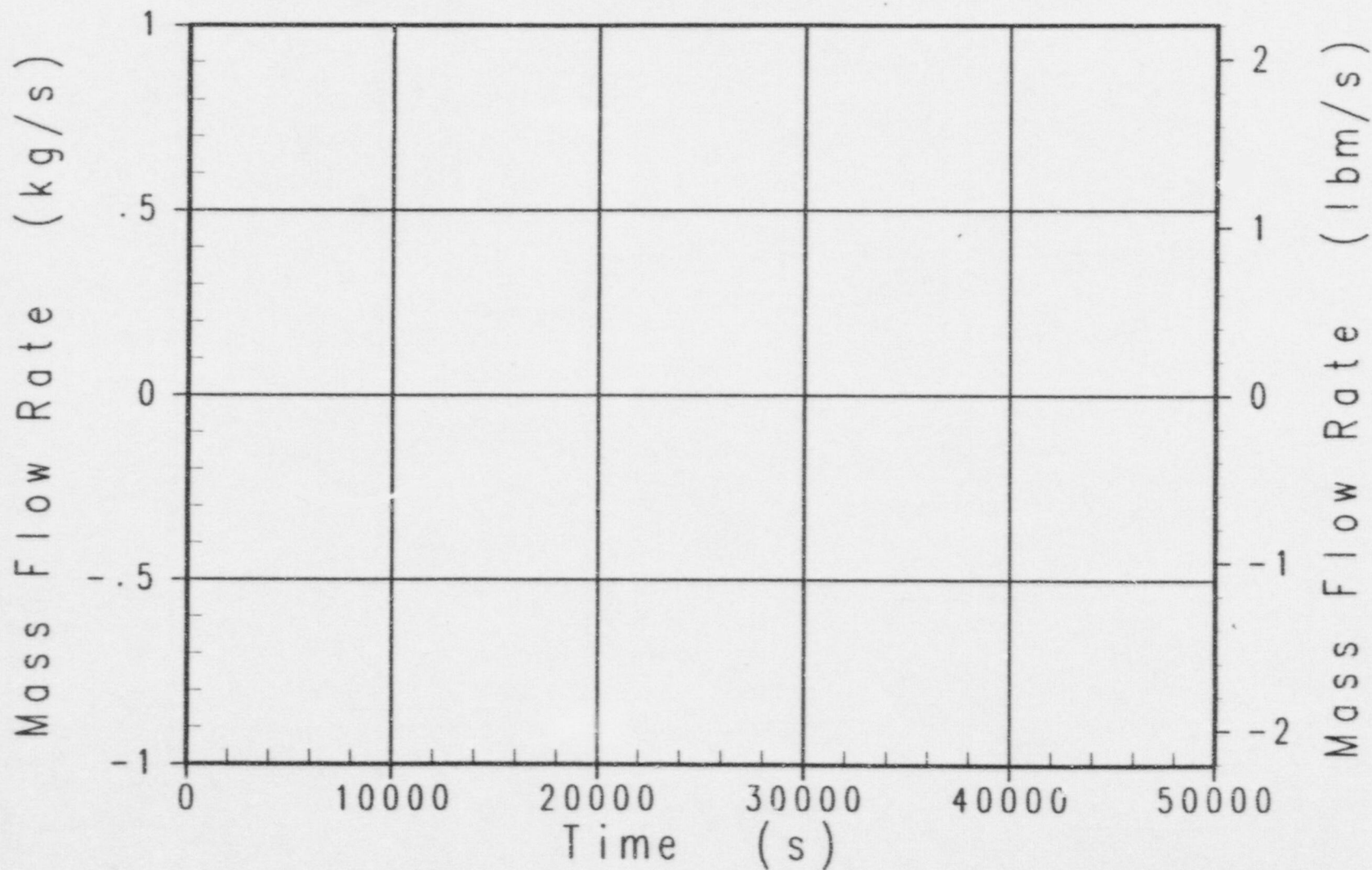

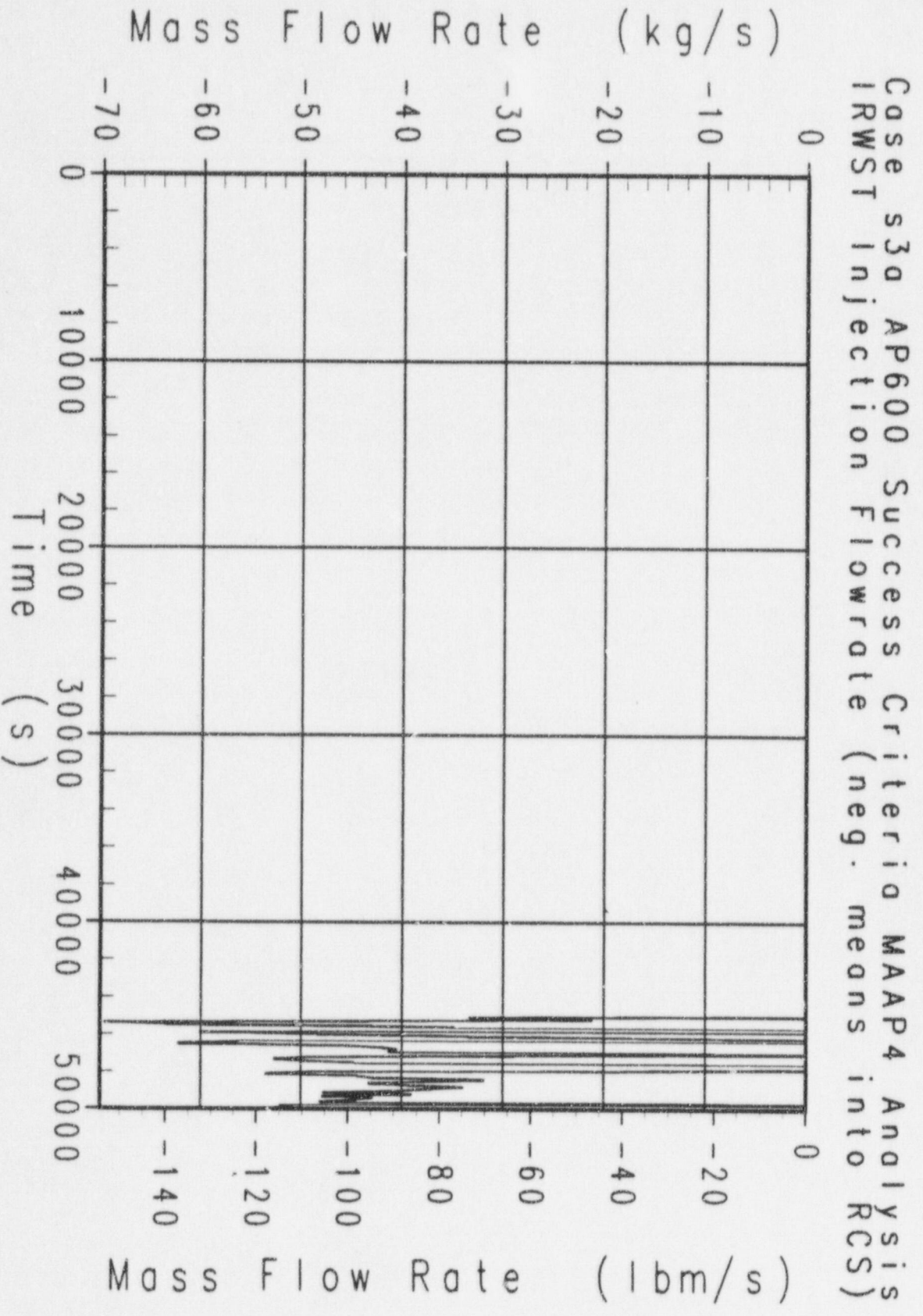

Case s30 AP600 Success Criteria MAA4 Analysis
CMT-1 Injection Flowrate

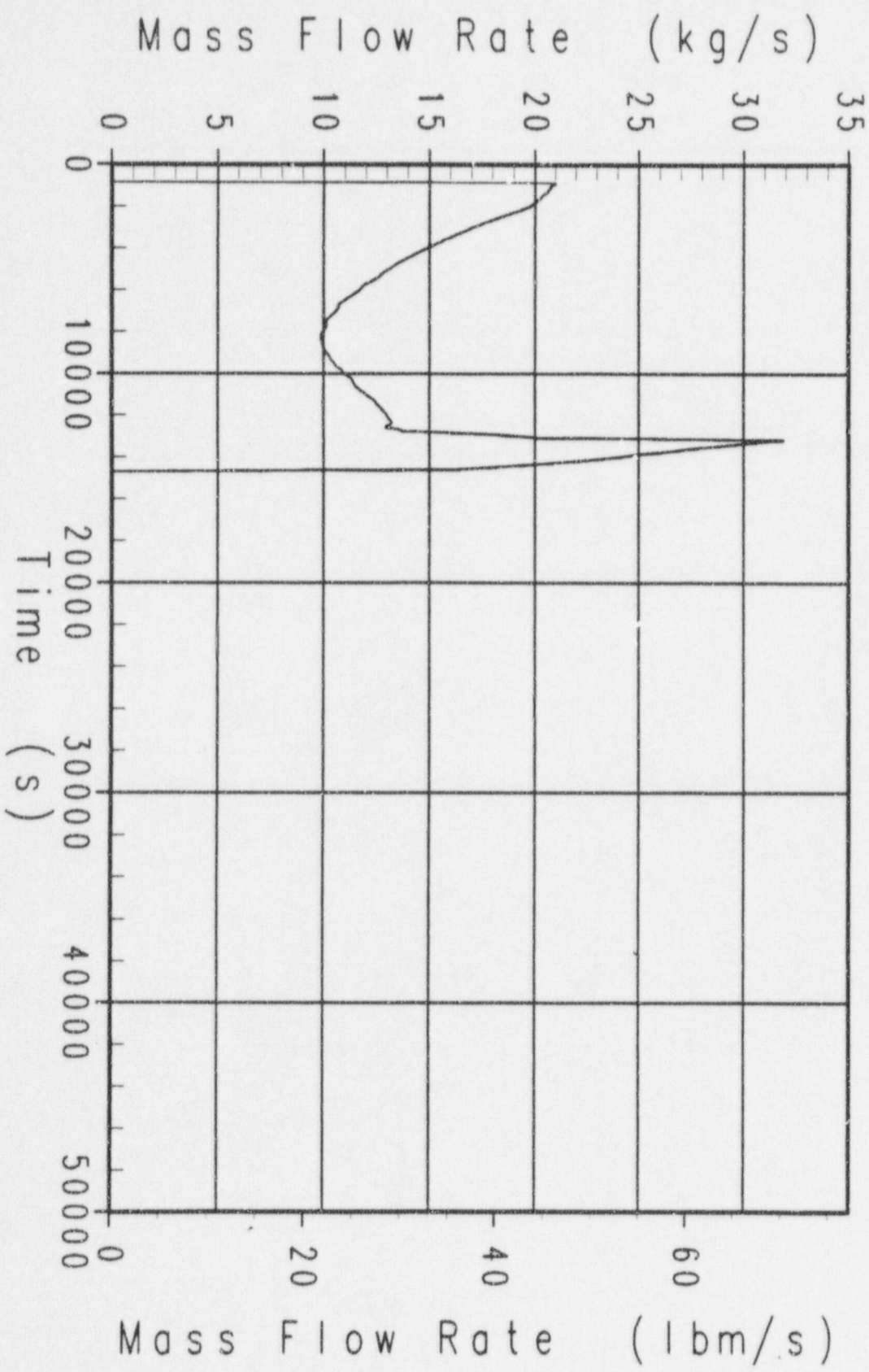

Mass Flow Rate (lbm/s)

Case s30 AP600 Success Criteria MAAp4 Analysis
Safety Valve and ADS Stages 1-3 Liquid Flowrate

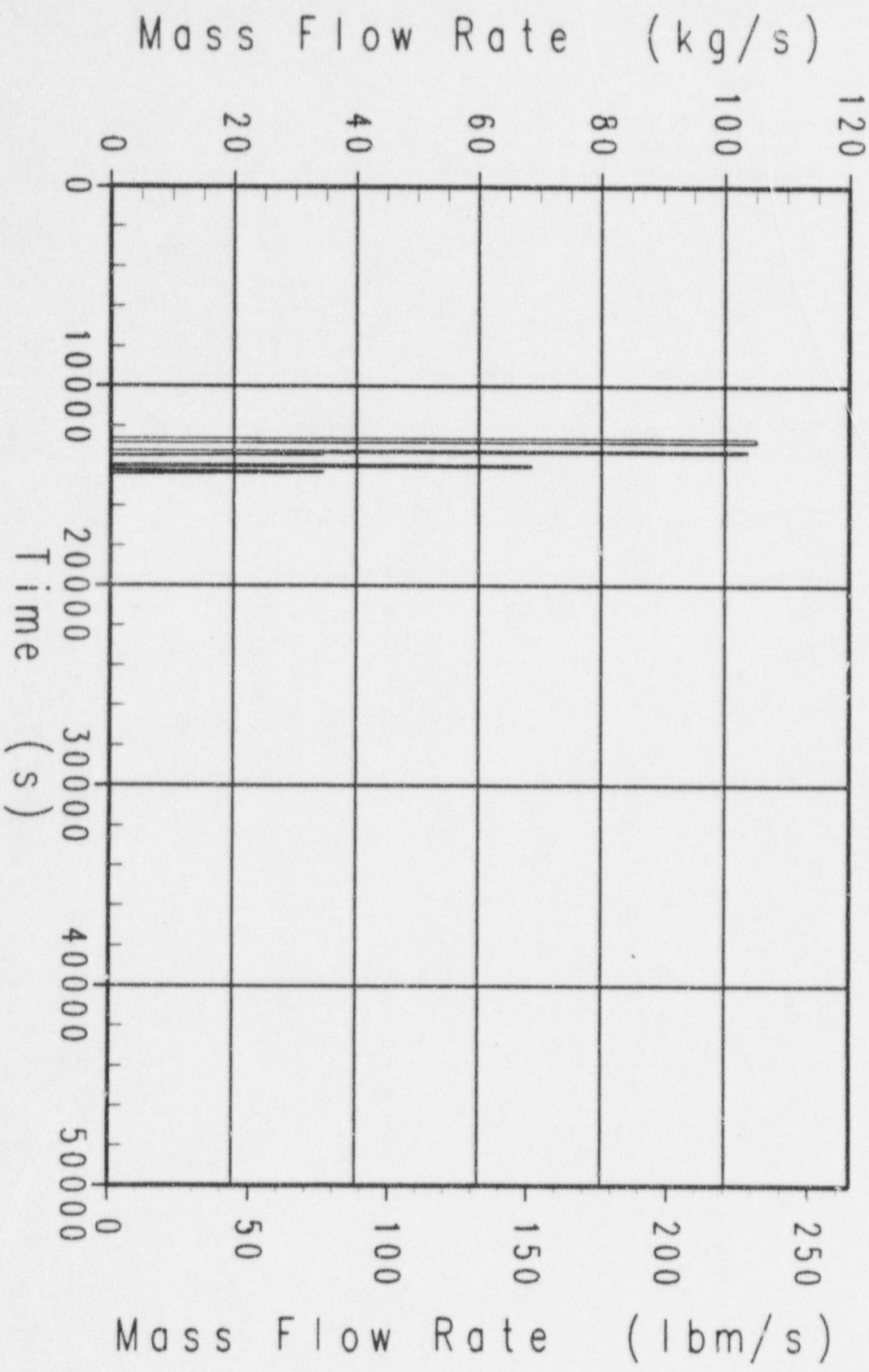

Case s3a AP600 Success Criteria MAAP4 Analysis
CMT-1 Water Level

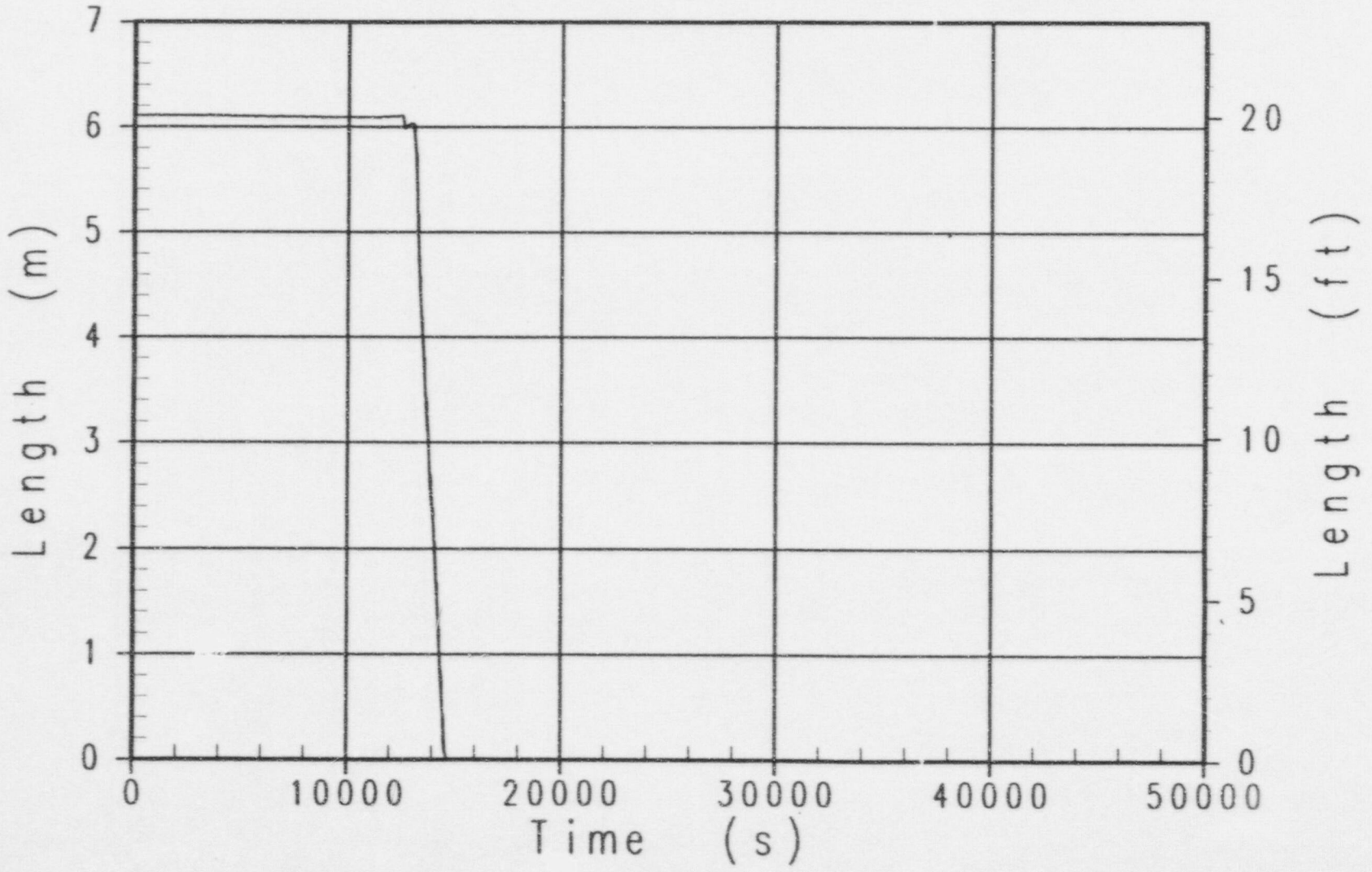

Case s3a AP600 Success Criteria MAAP4 Analysis
Pressurizer Water Level (From Pzr Bottom)

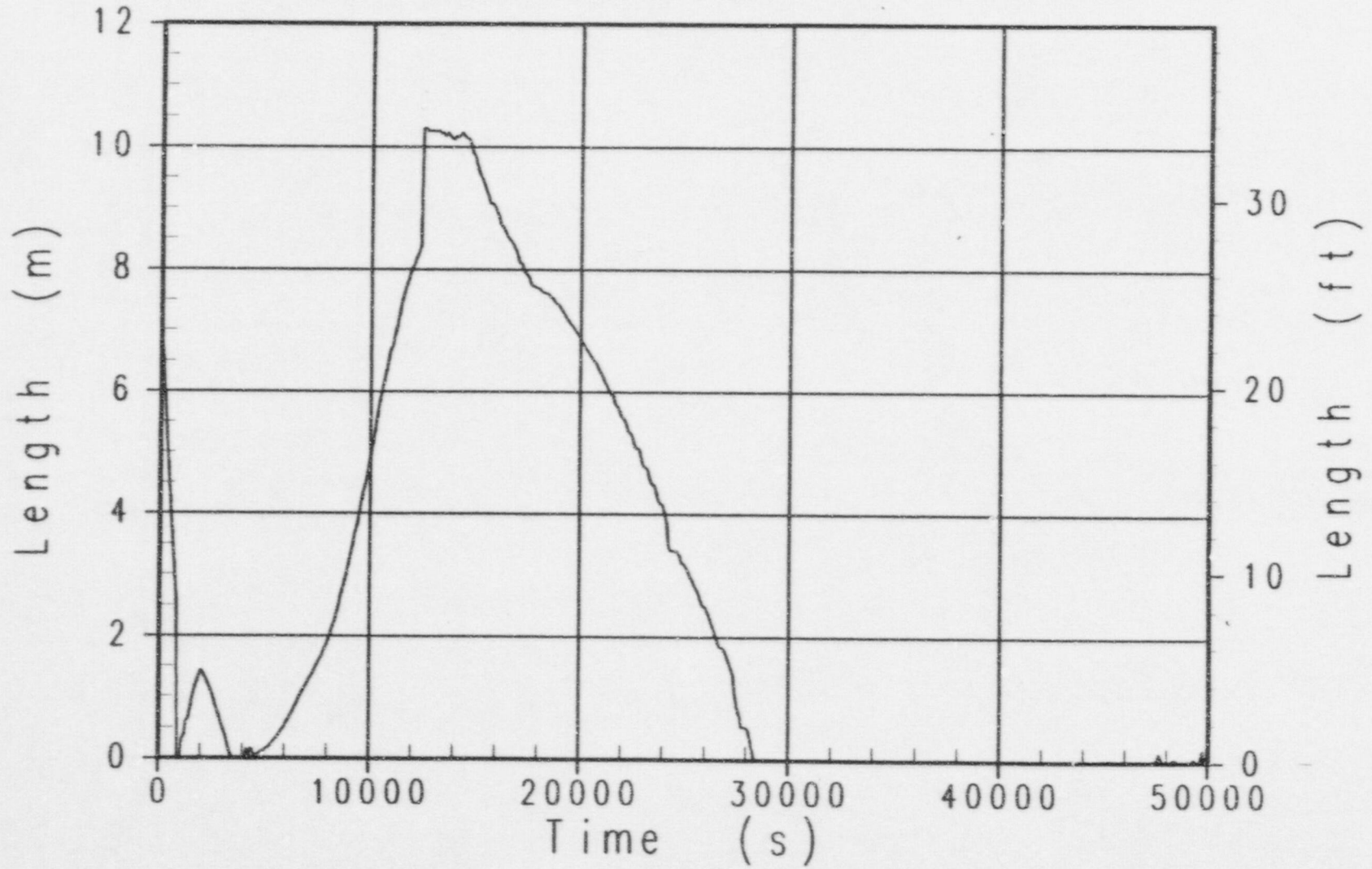

Case s3b2 AP600 Success Criteria MAAP4 Analysis
Broken Loop Steam Generator Pressure

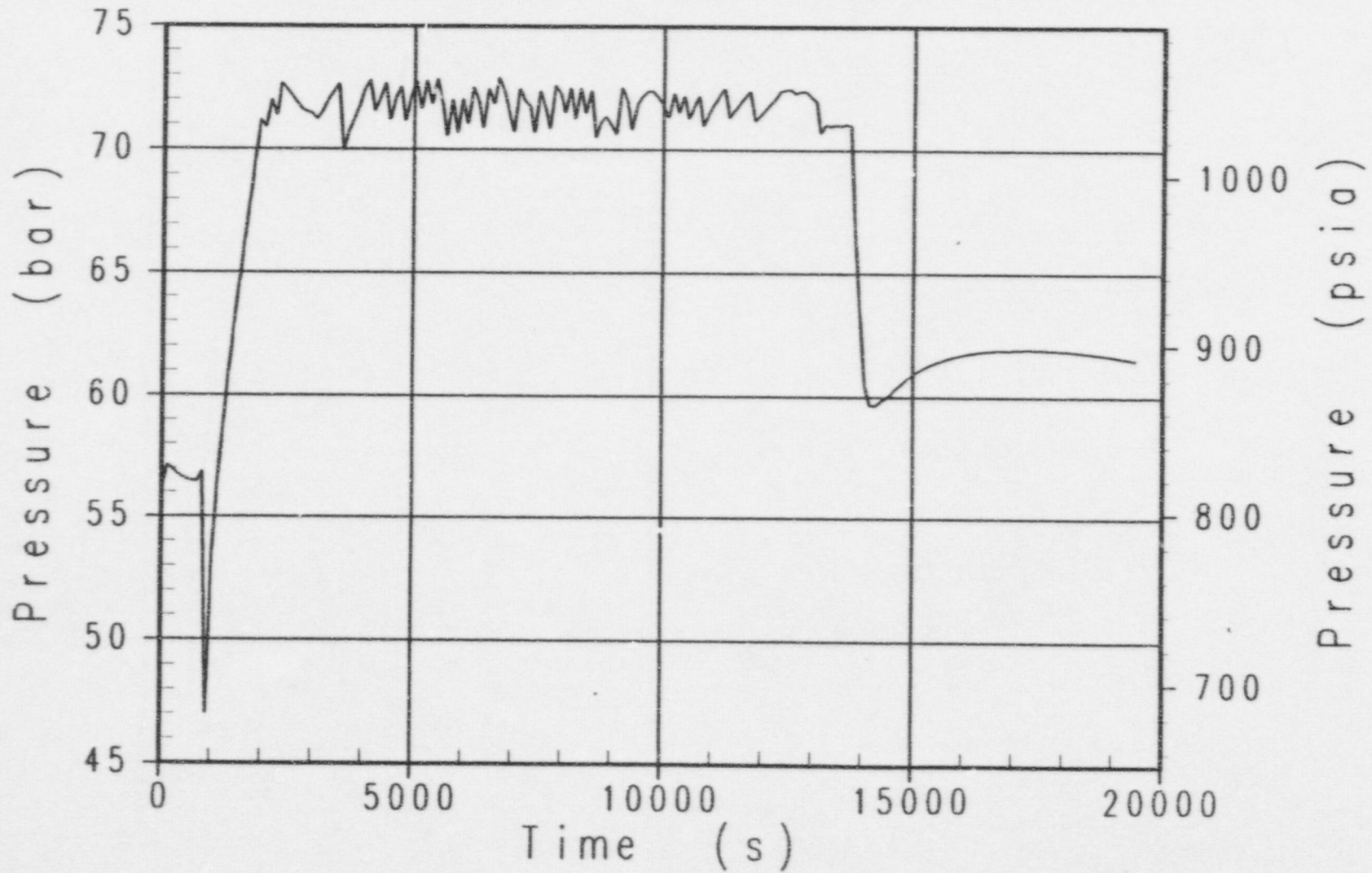

Case s3b2 AP600 Success Criteria MAAP4 Analysis
Primary System Pressure

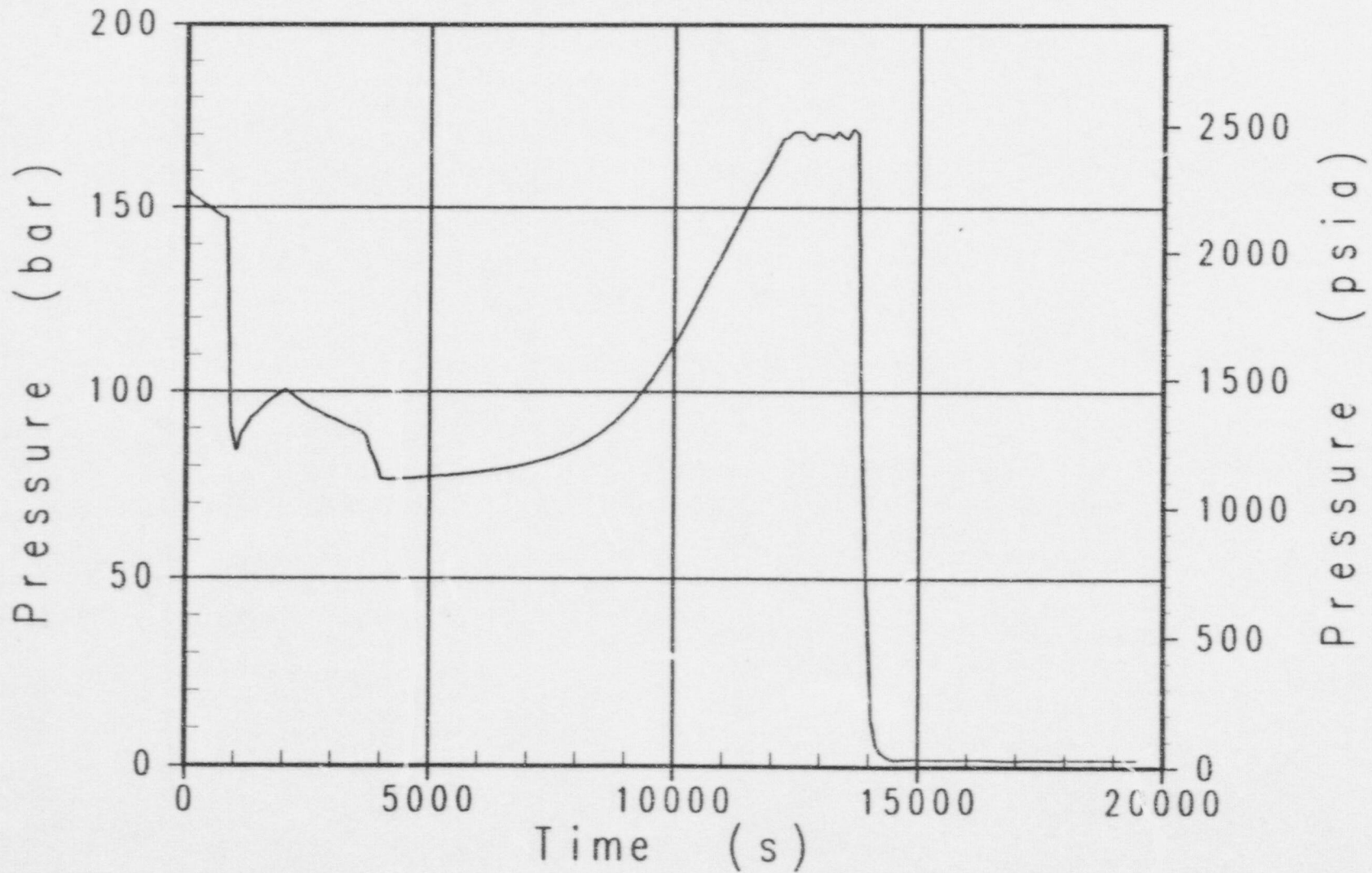

Case s3b2 AP600 Success Criteria MAAP4 Analysis
Containment Pressure

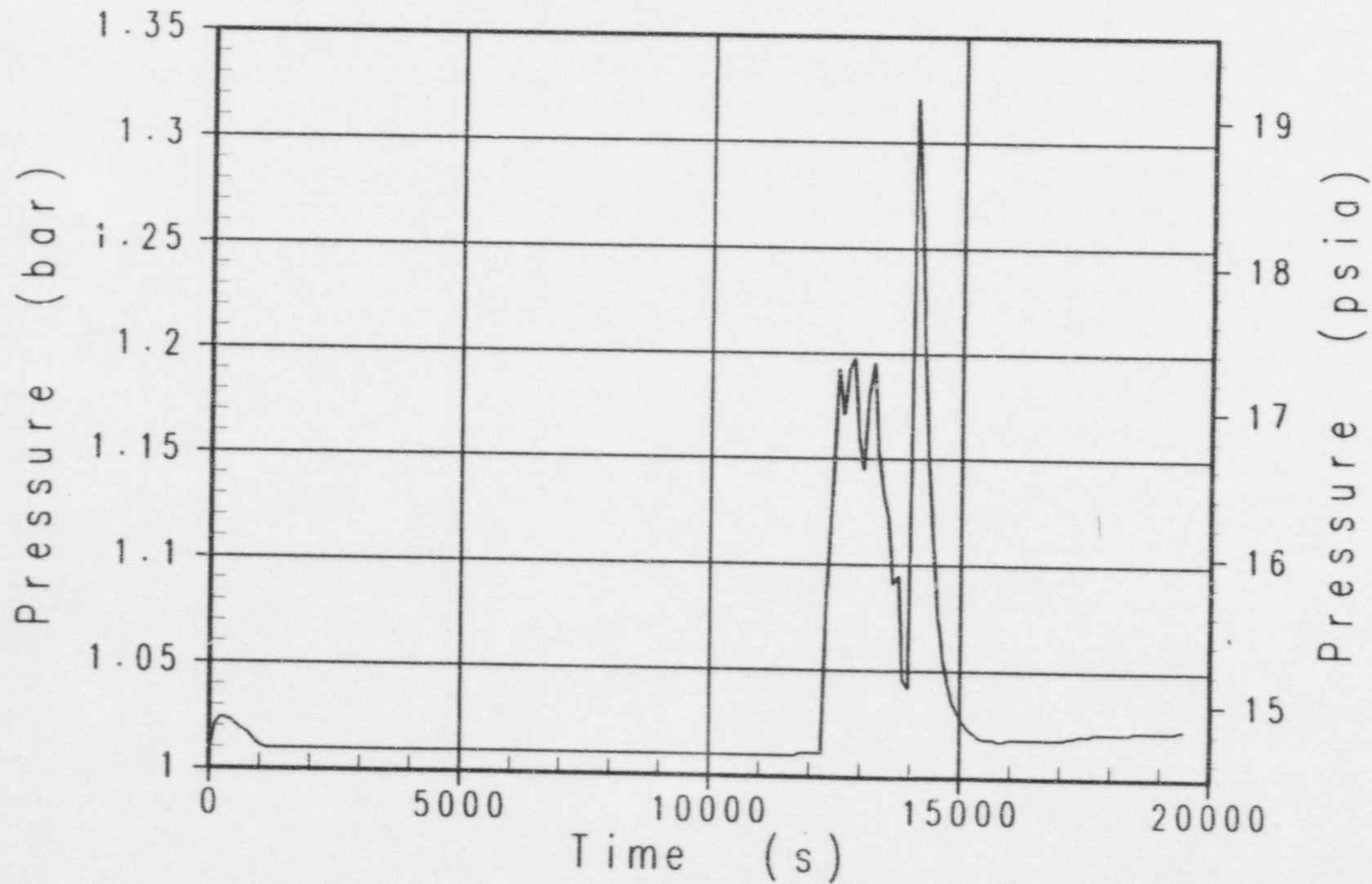

Case s3b2 AP600 Success Criteria MAAP4 Analysis
Unbroken Loop Steam Generator Pressure

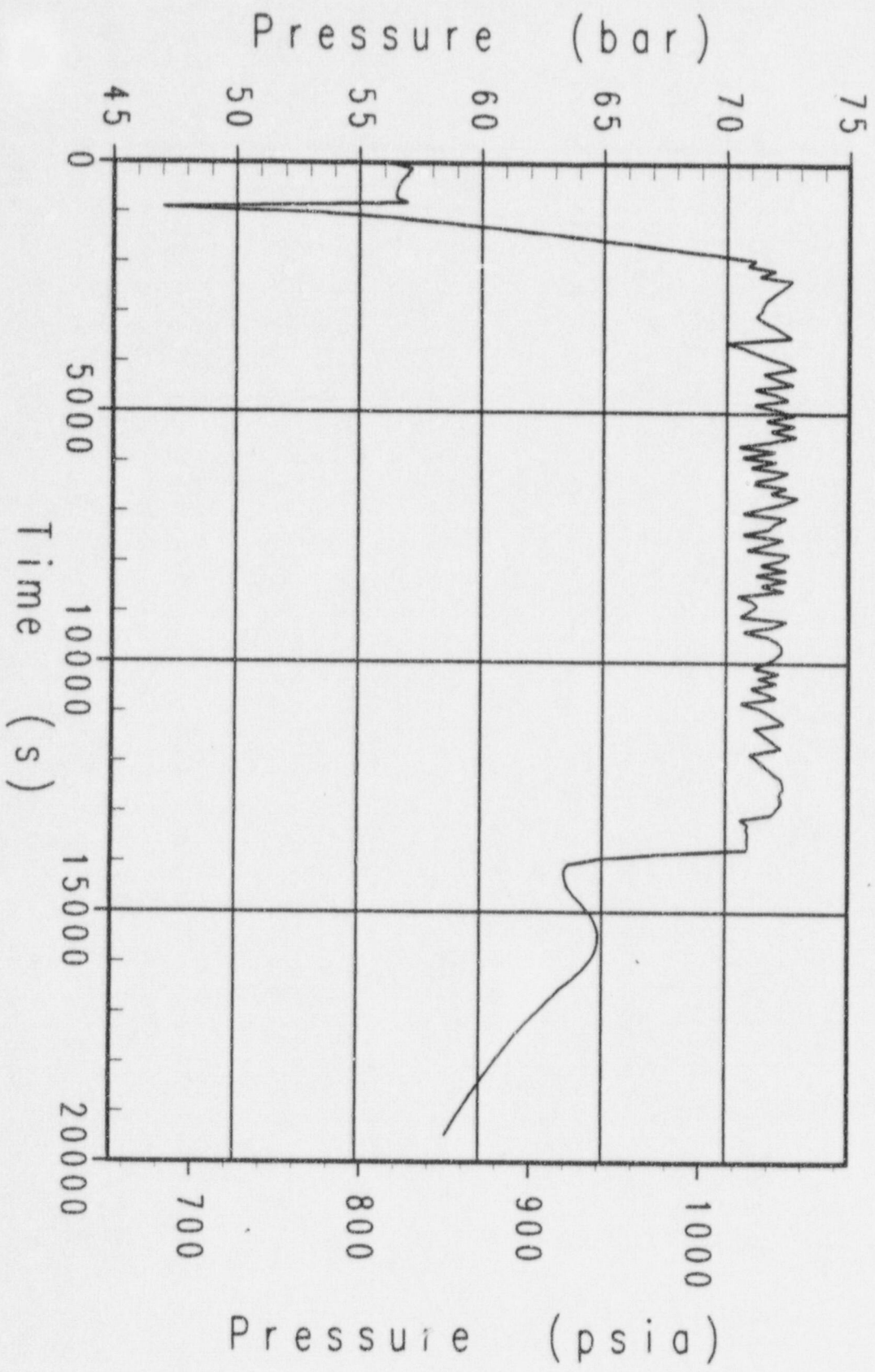

Case s3b2 AP600 Success Criteria MAAP4 Analysis
Decay Power

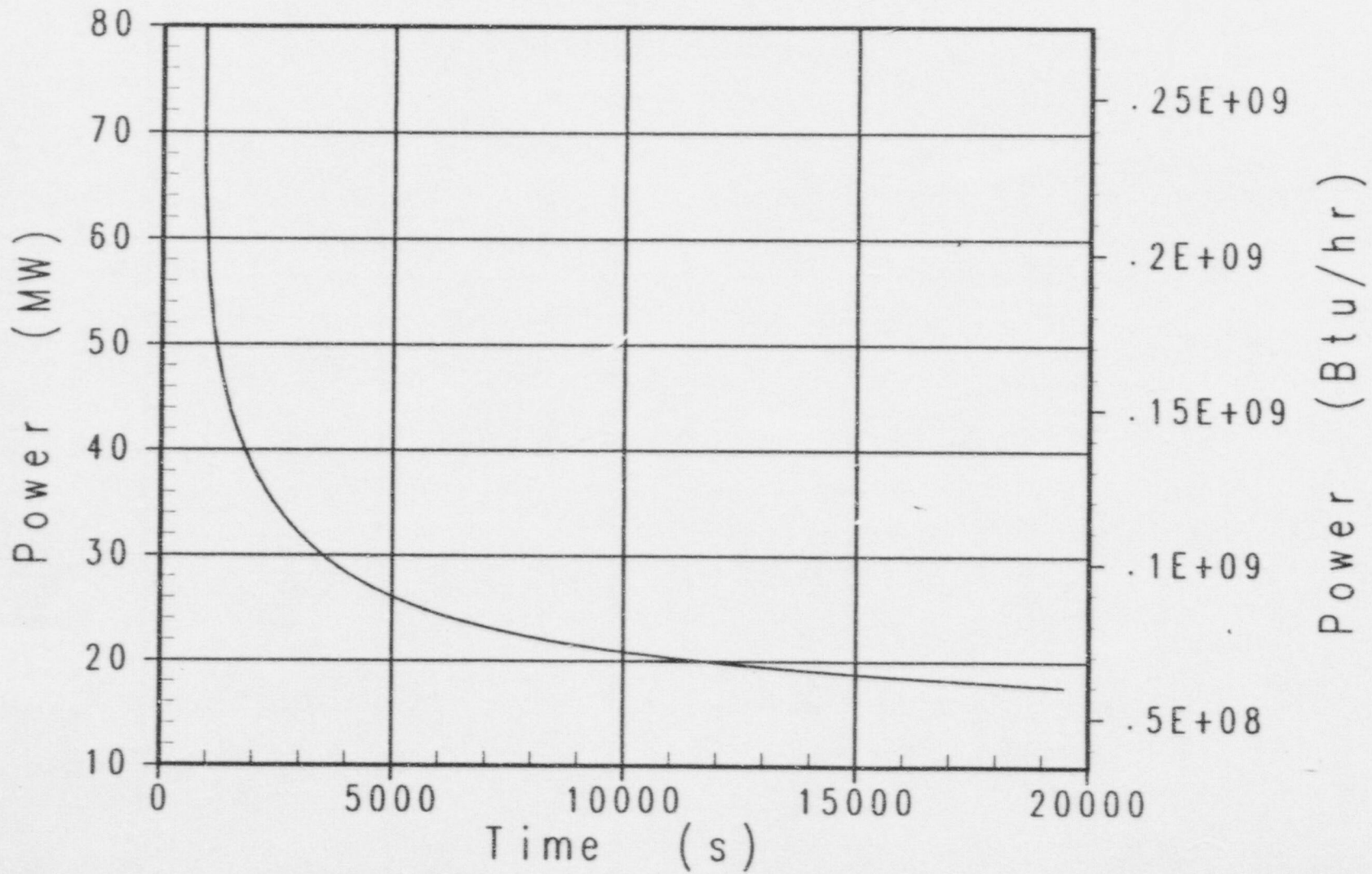

Case s3b2 AP600 Success Criteria MAAP4 Analysis
PRHR Heat Removal Rate

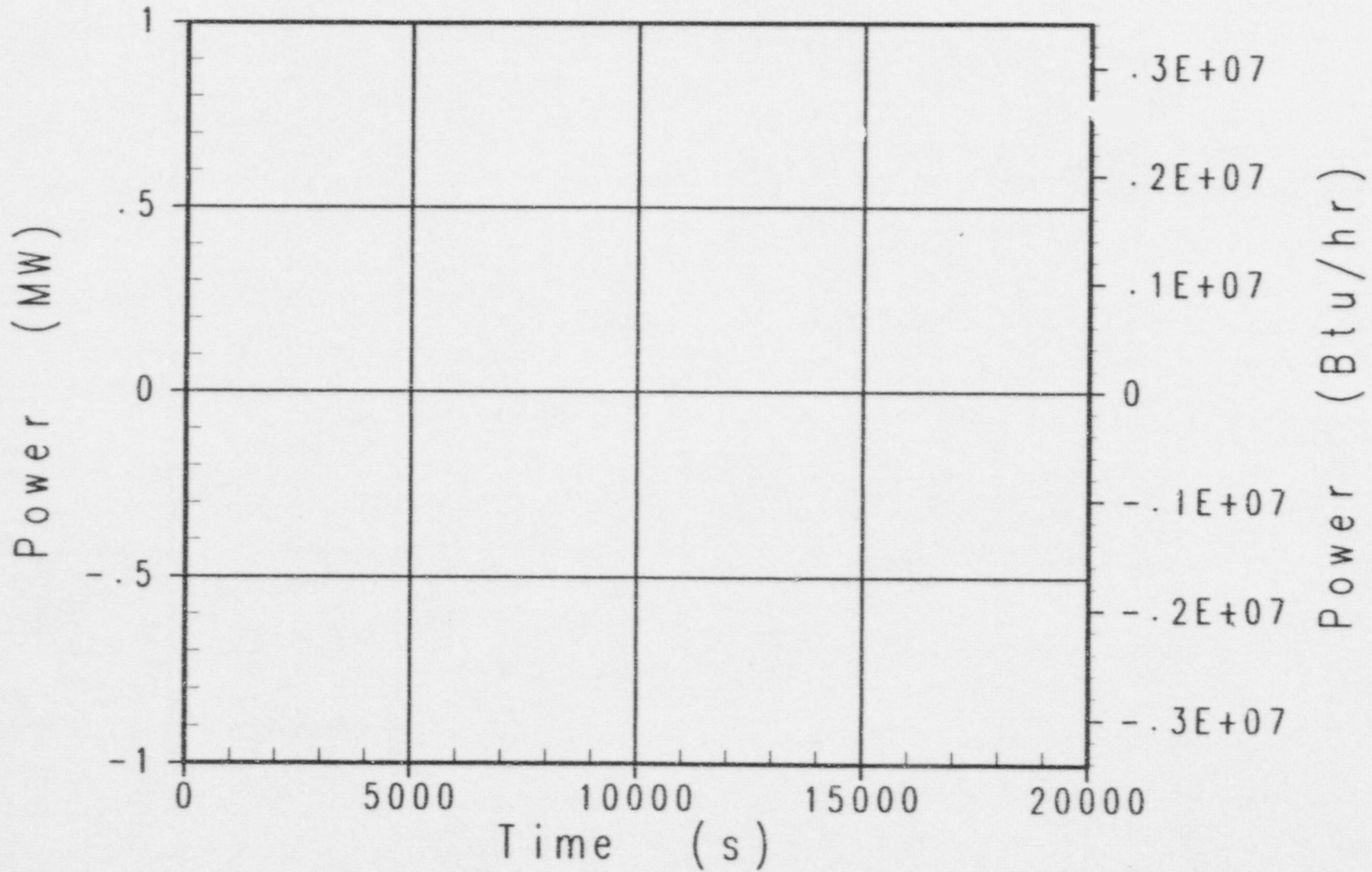

Case s3b2 AP600 Success Criteria MAAP4 Analysis
Peak Temperature in the Core

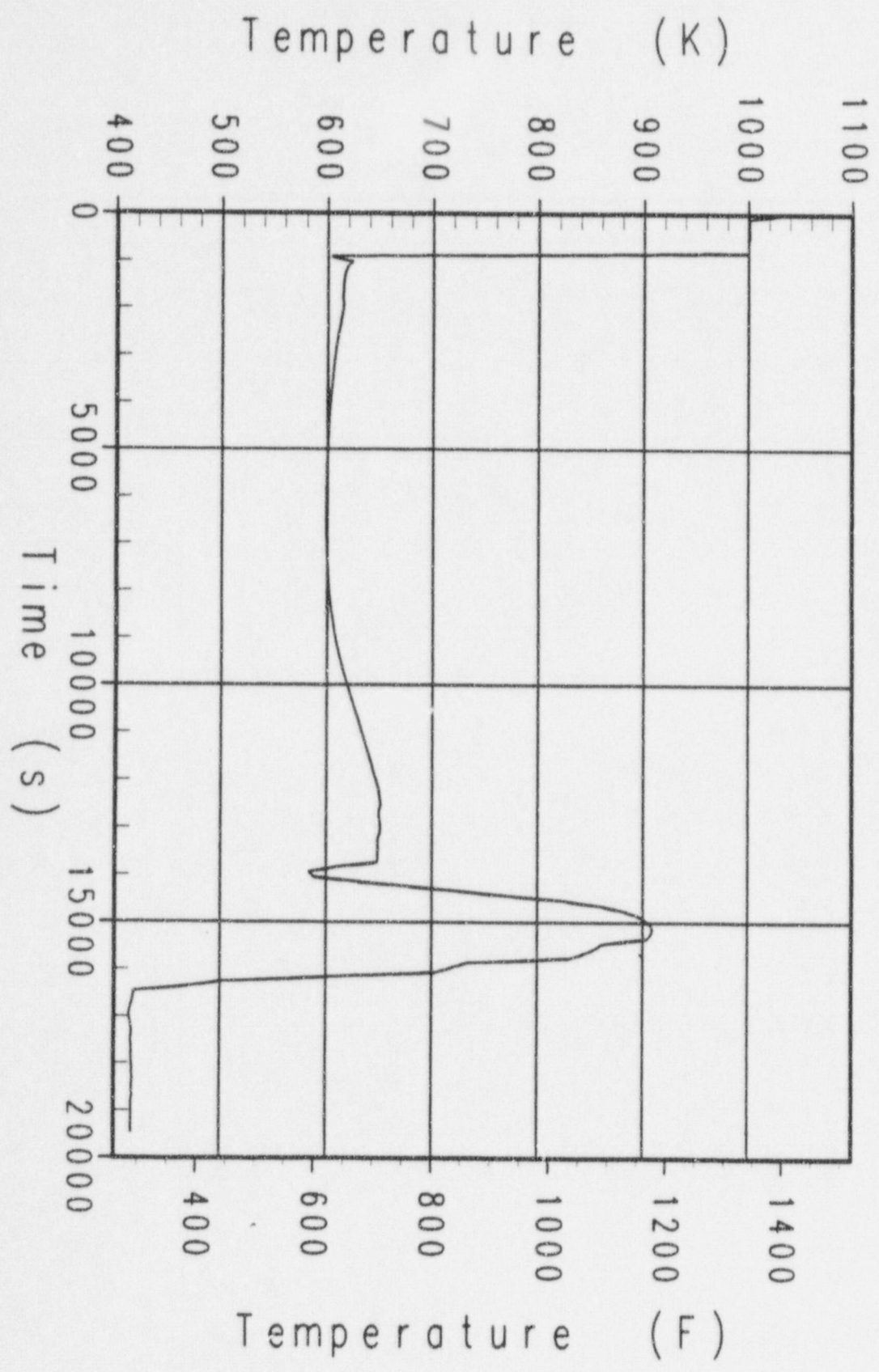

Case s3b2 AP600 Success Criteria MAAP4 Analysis
Cold Leg Water Temperature

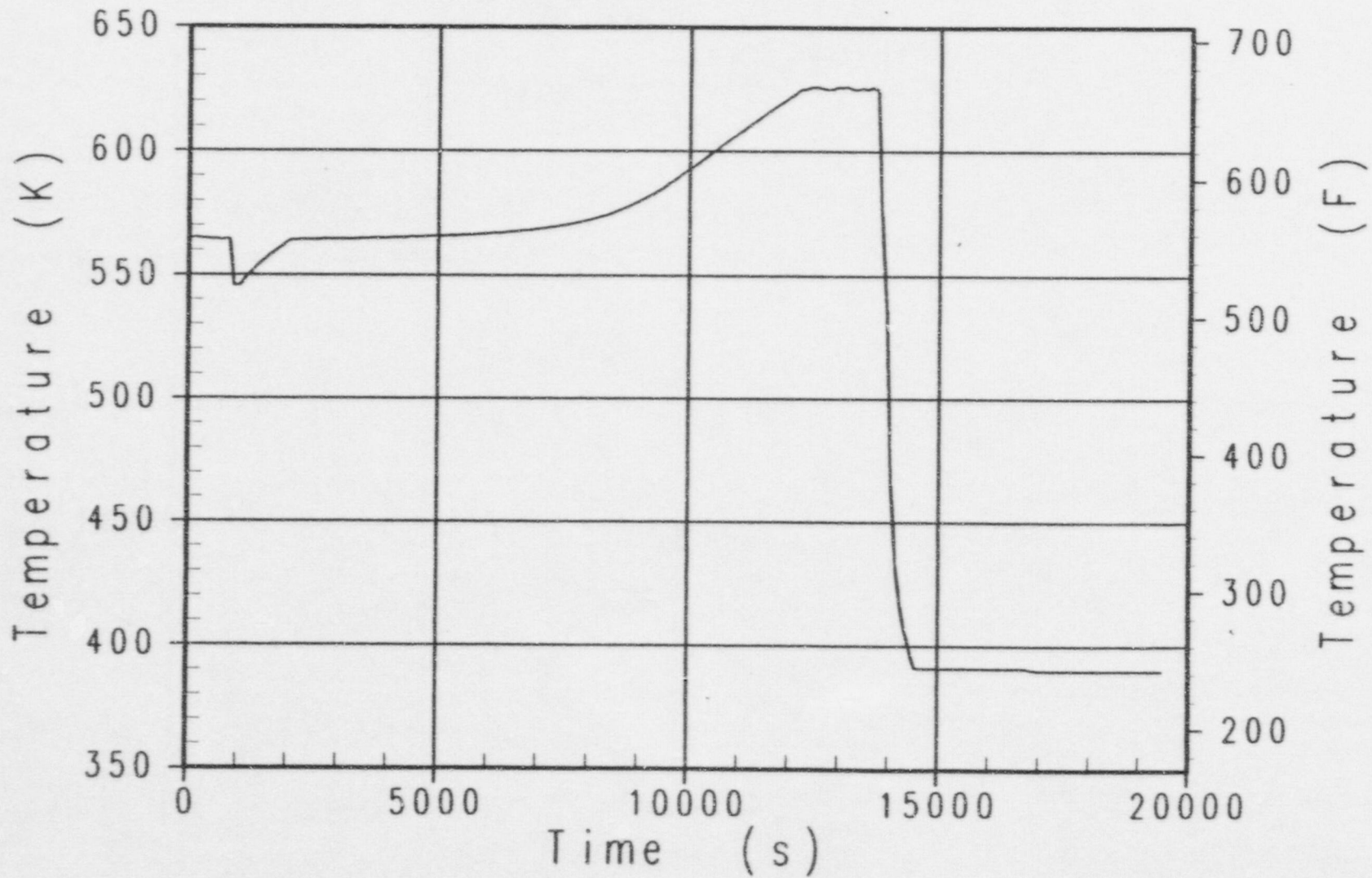

Case s3b2 AP600 Success Criteria MAAP4 Analysis
Core Water Temperature

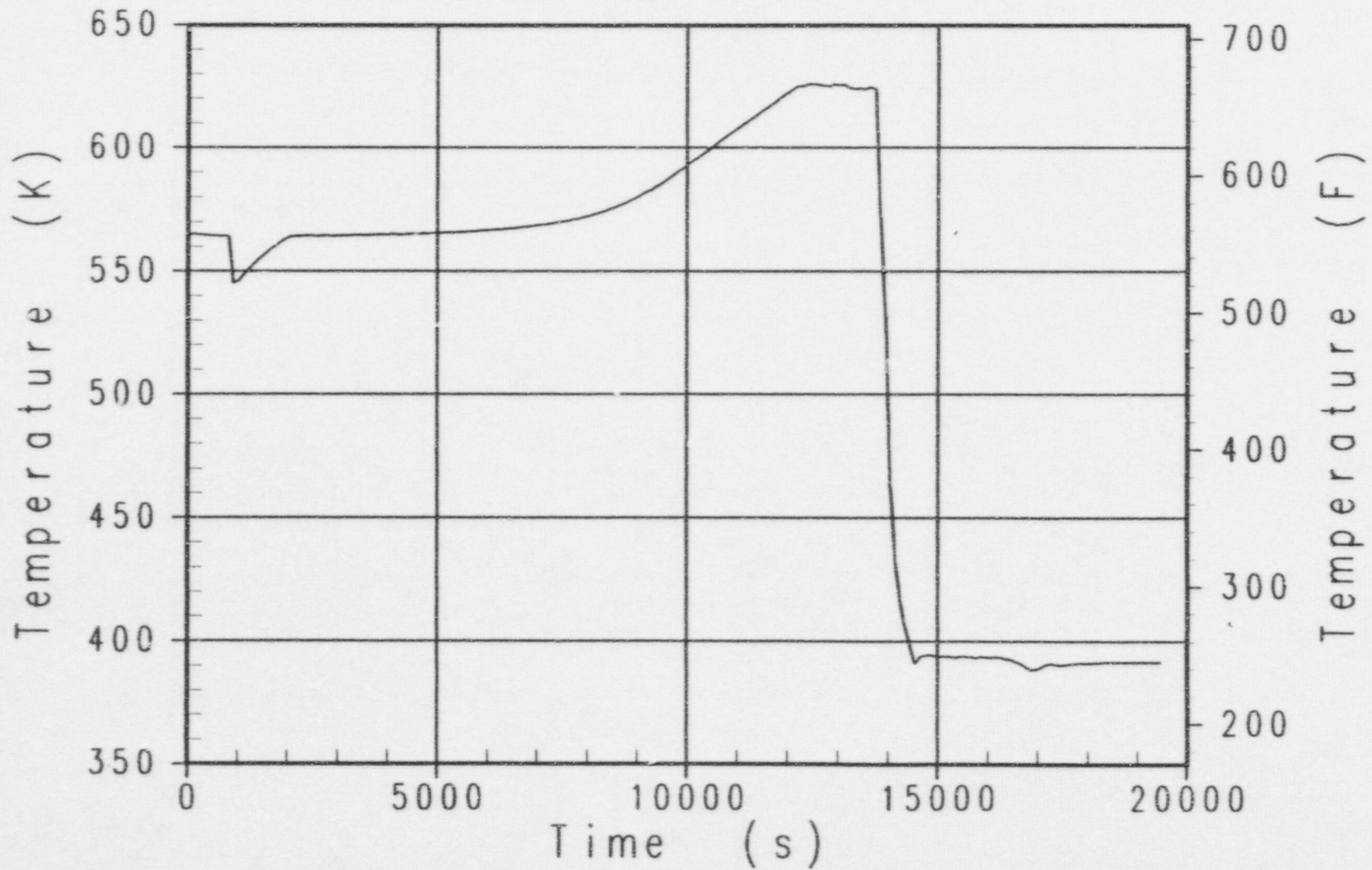

Case s3b2 AP600 Success Criteria MAAP4 Analysis
RPV Downcomer Water Temperature

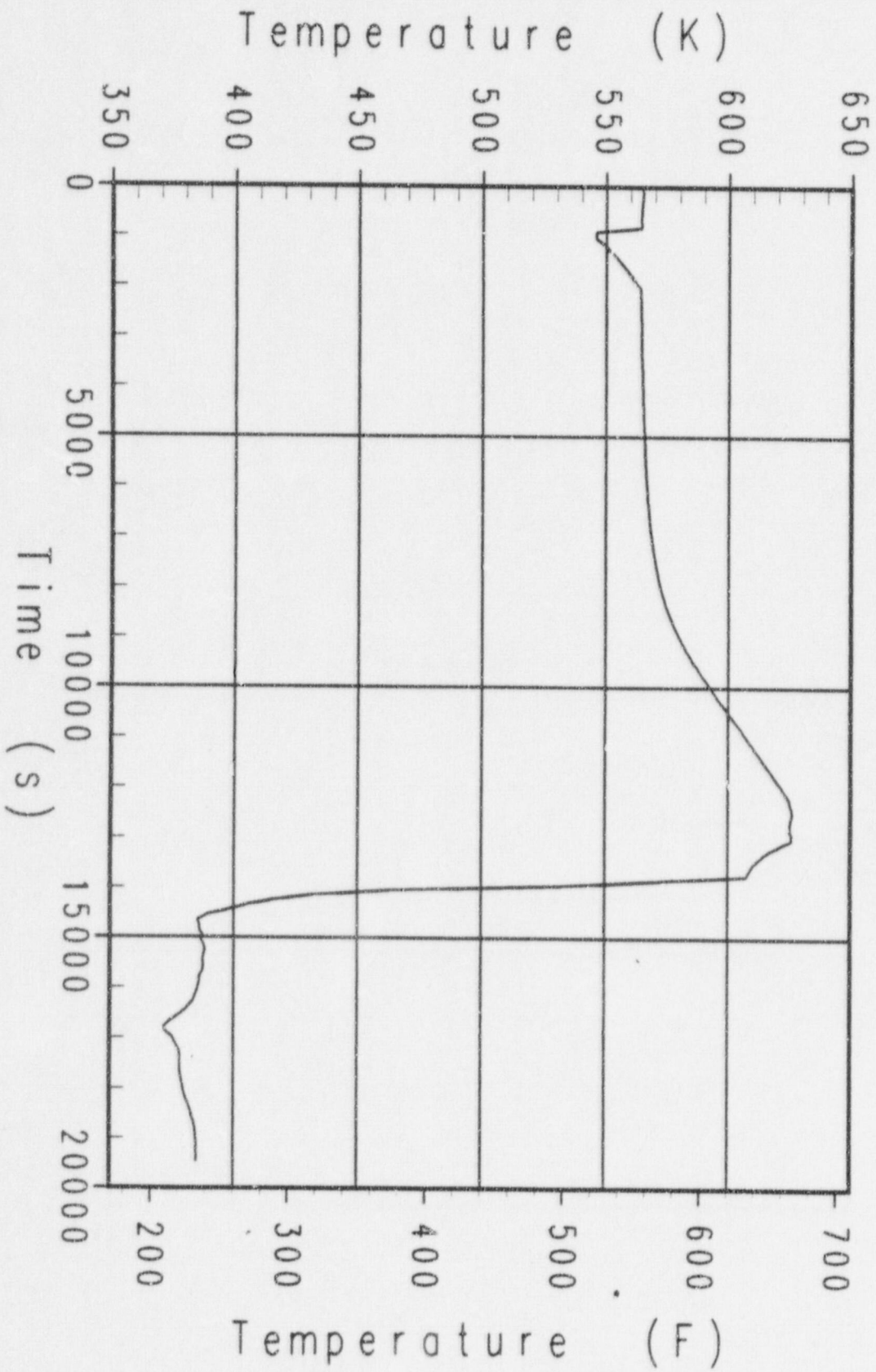

Case s3b2 AP600 Success Criteria MAA4 Analysis
IRWST Water Temperature

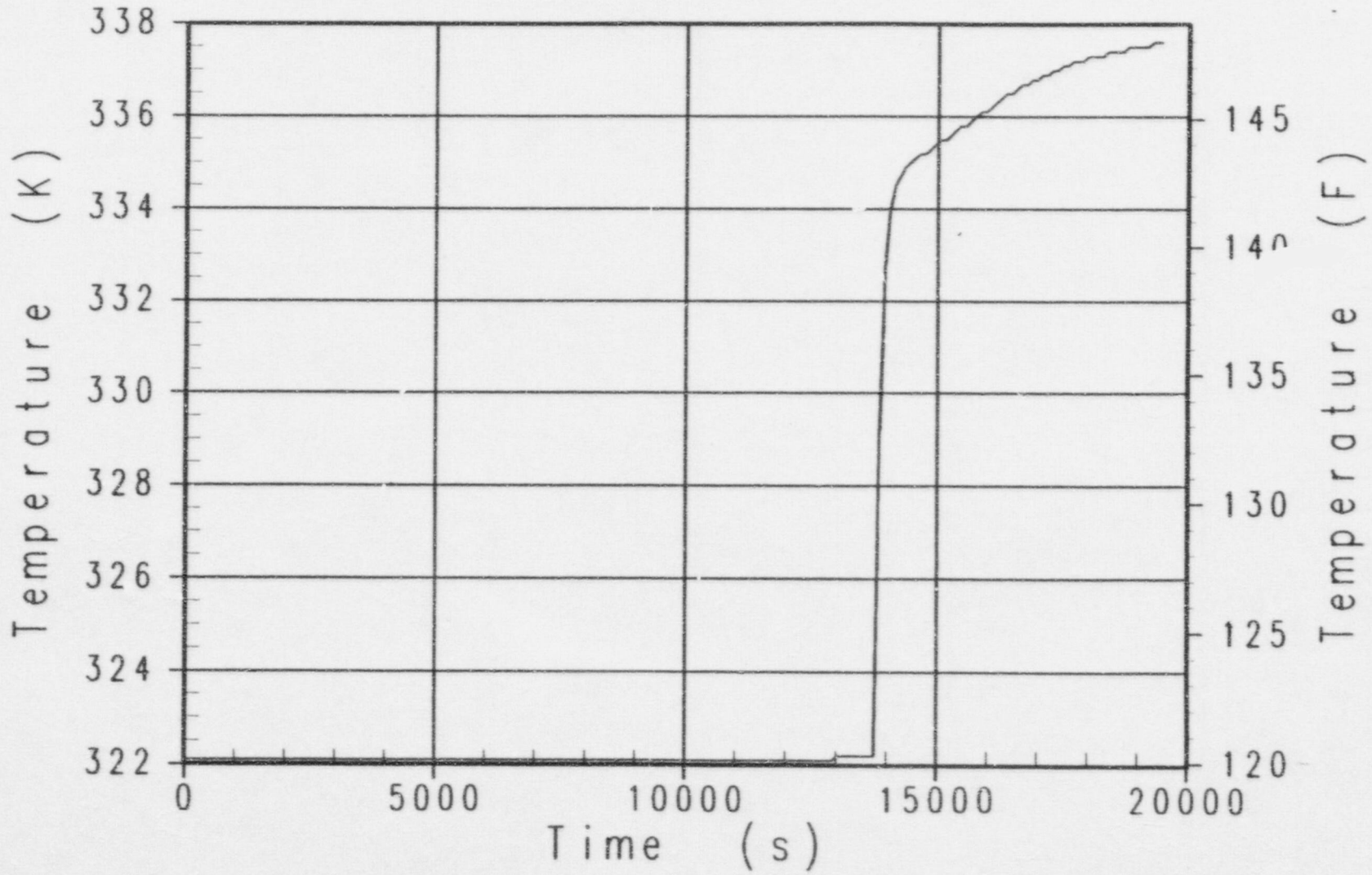

Case s3b2 AP600 Success Criteria MAAP4 Analysis
Accumulator and NRHR Injection Flowrate

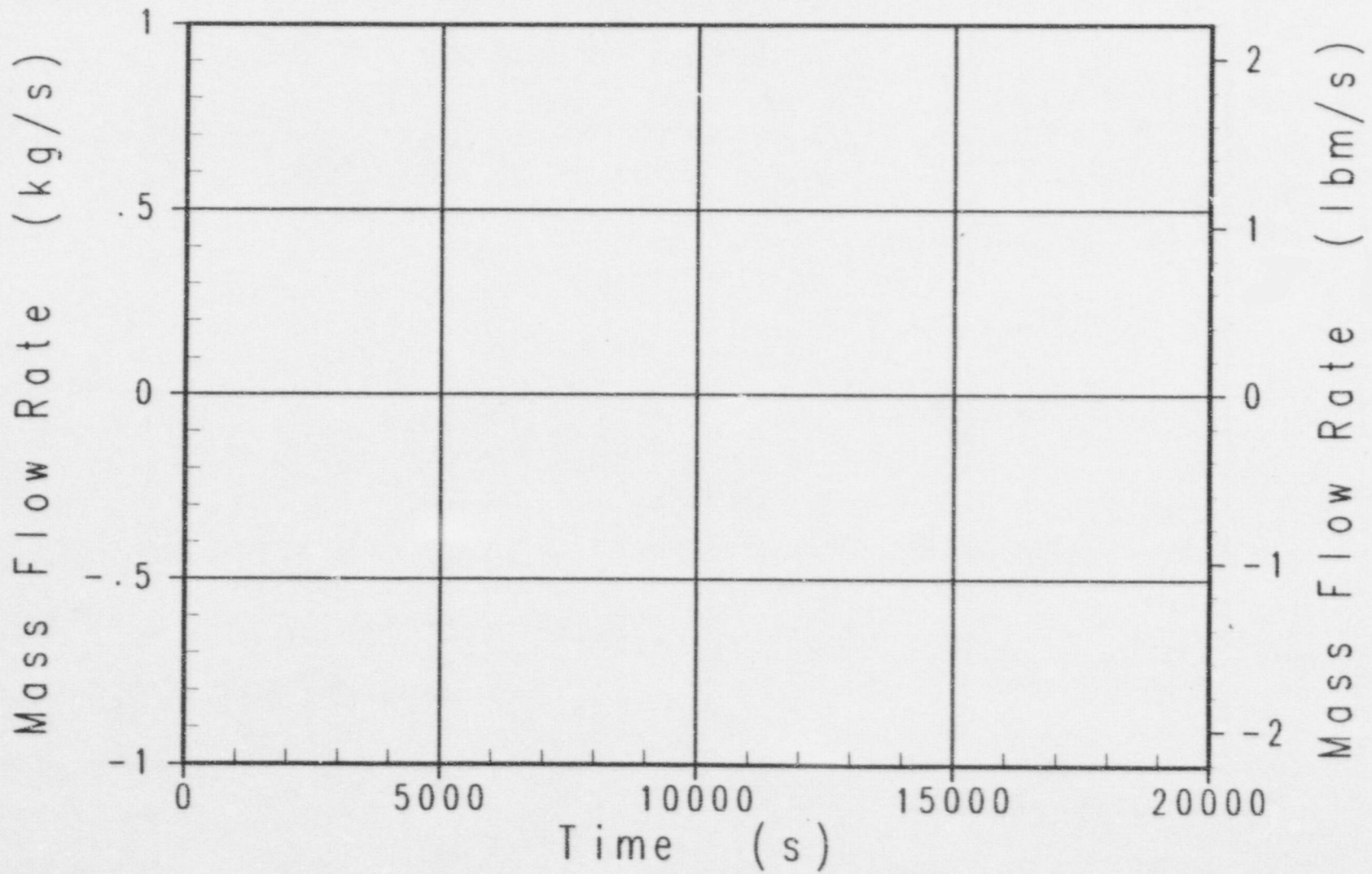

Case s3b2 AP600 Success Criteria MAAP4 Analysis
RCS Break Gas Flowrate

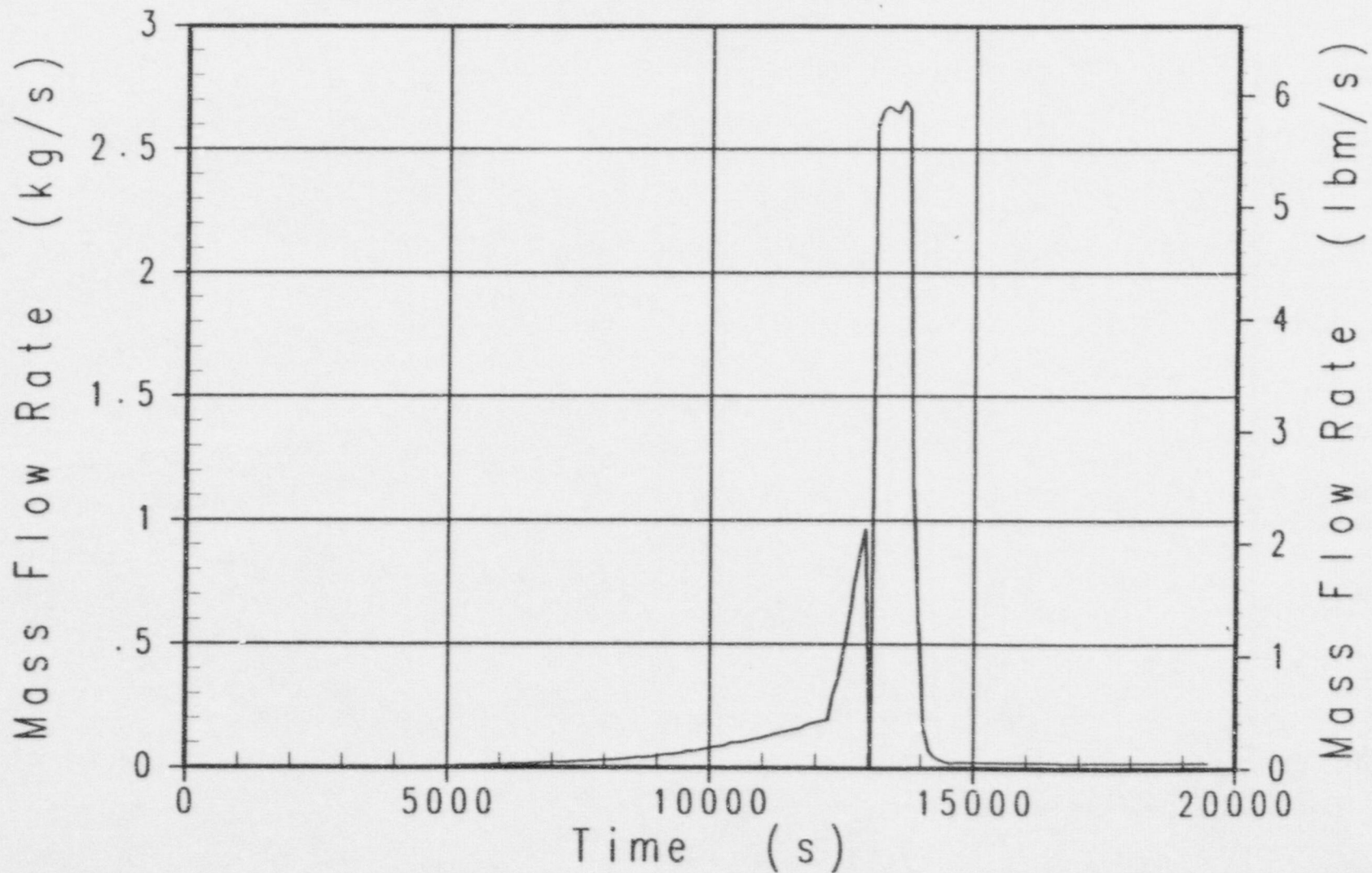

Case s3b2 AP600 Success Criteria MAAP4 Analysis
ADS Stage 4 Gas Flowrate

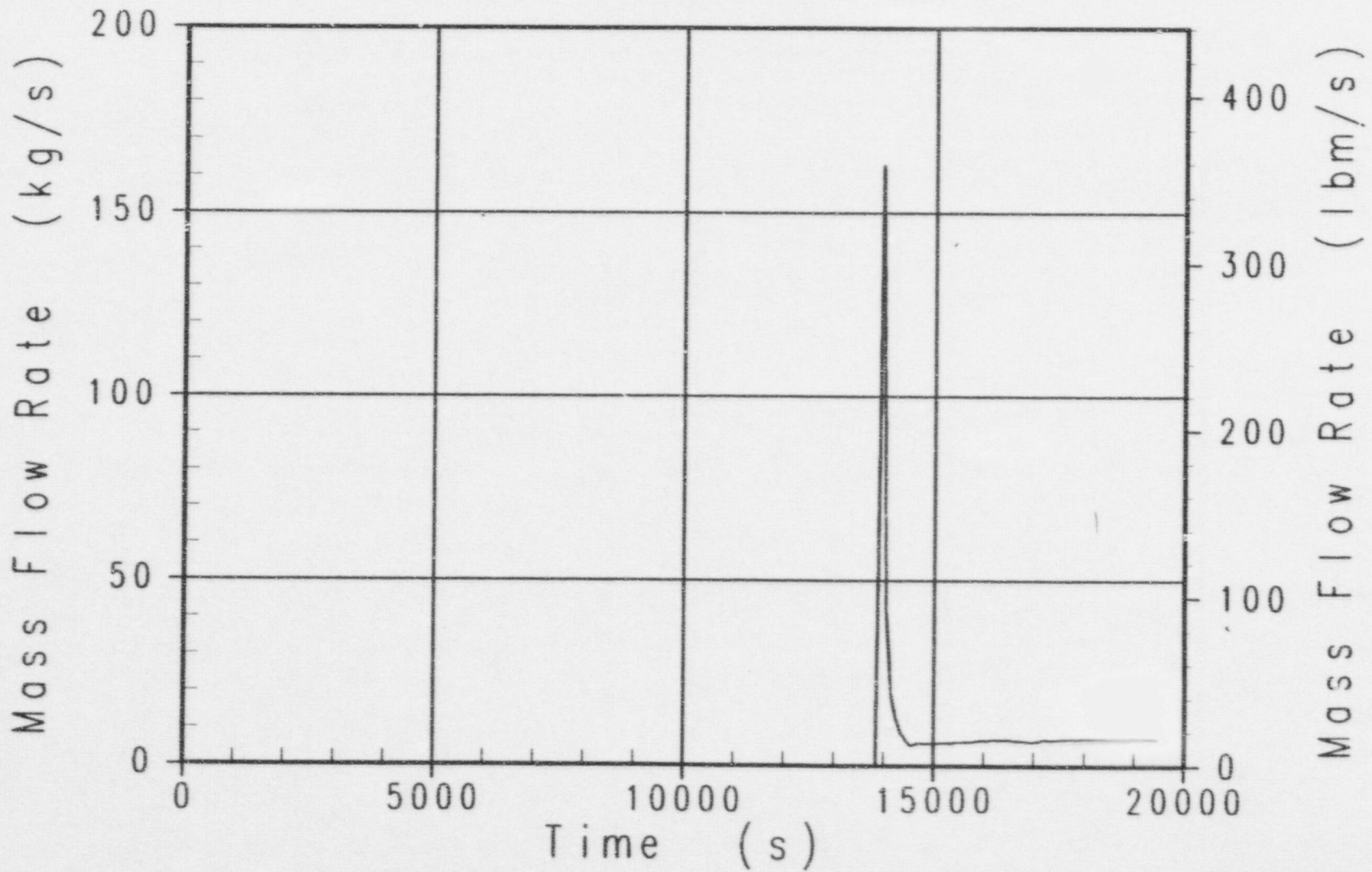

Case s3b2 AP600 Success Criteria MAAP4 Analysis
Safety Valve and ADS Stages 1-3 Gas Flowrate

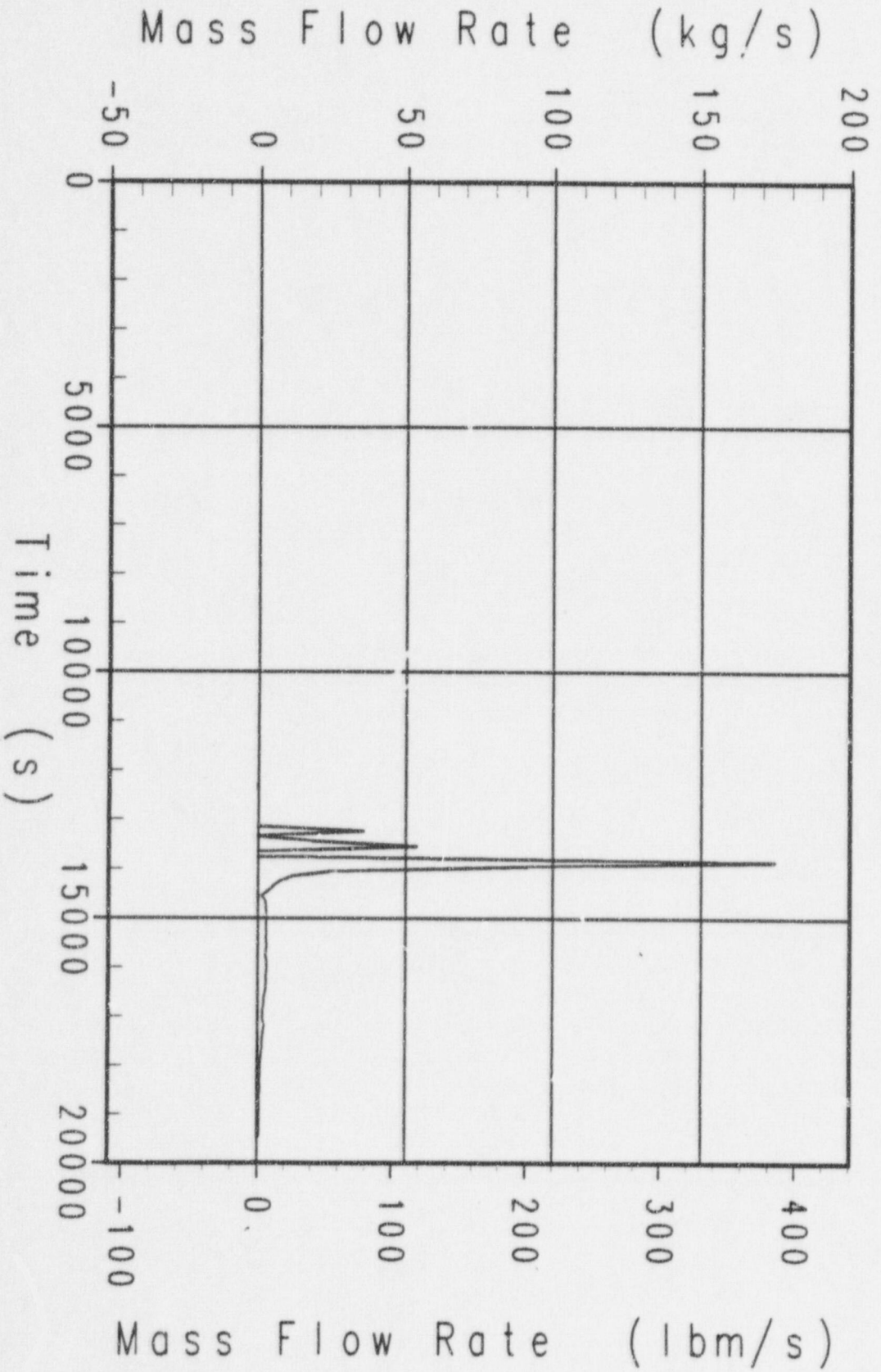

Case s3b2 AP600 Success Criteria MAAP4 Analysis
RCS Break Liquid Flowrate

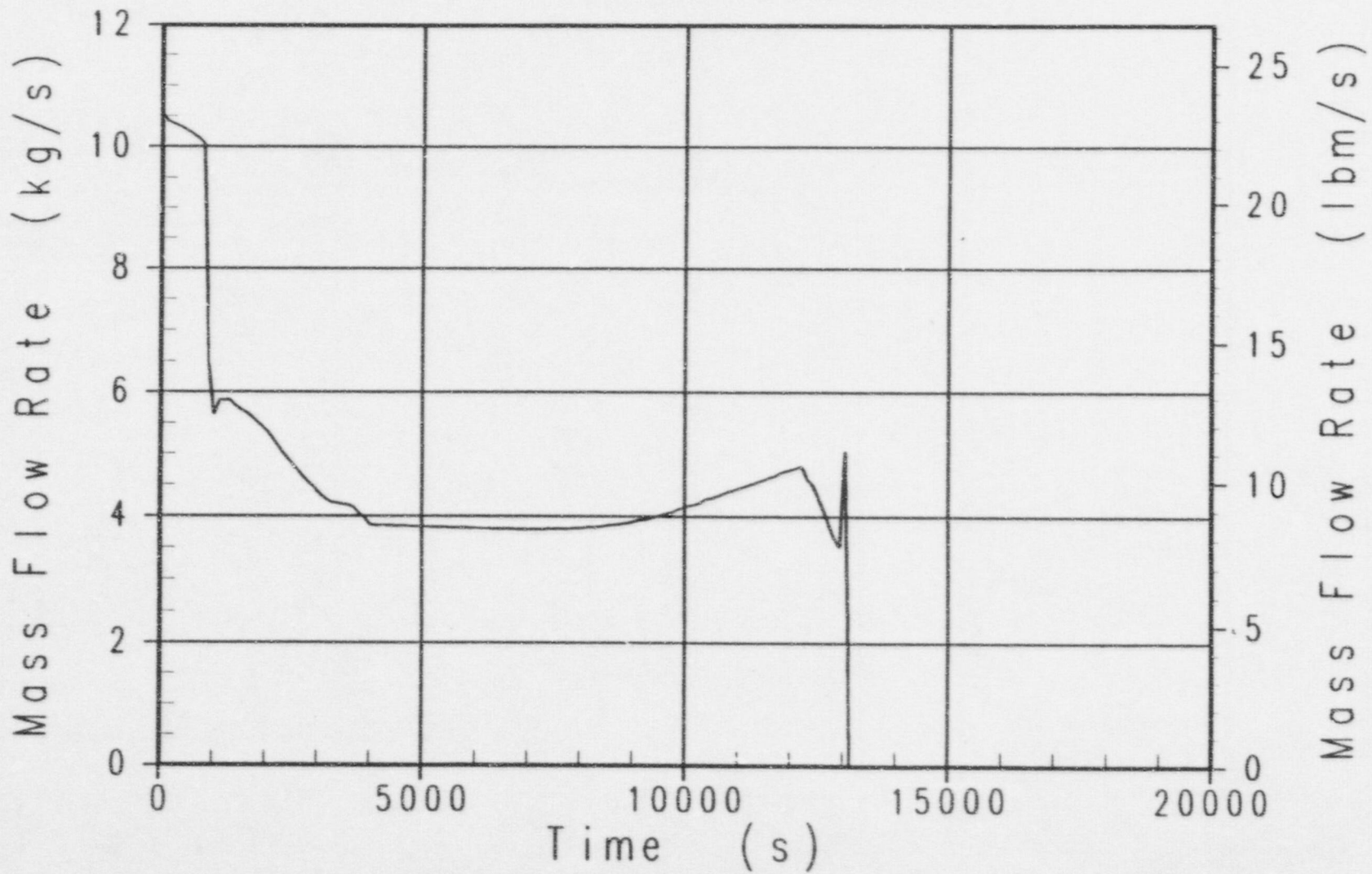

Case s3b2 AP600 Success Criteria MAAP4 Analysis
ADS Stage 4 Liquid Flowrate

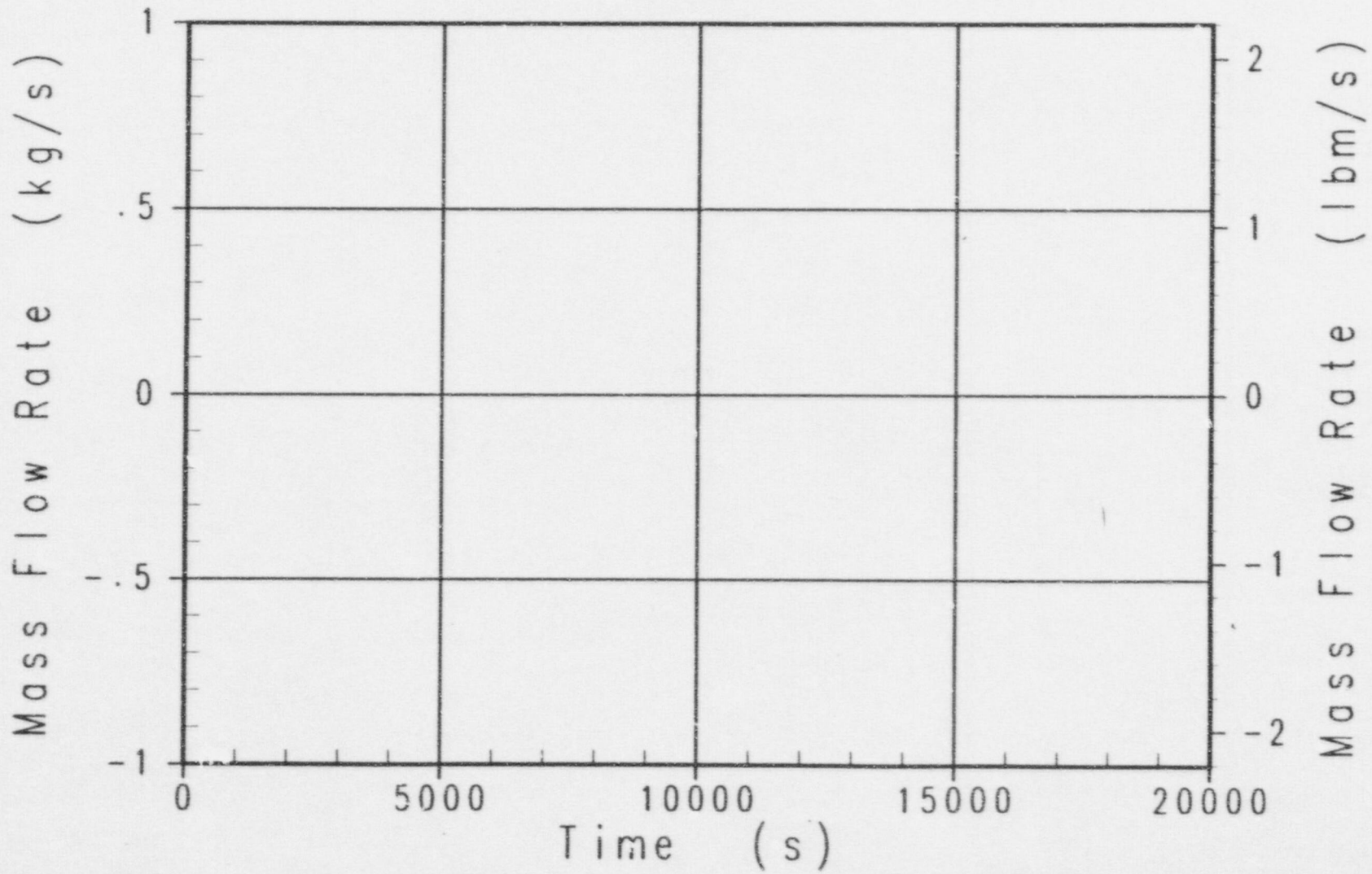

Case s3b2 AP600 Success Criteria MAAP4 Analysis
IRWST Injection Flowrate (neg. means into RCS)

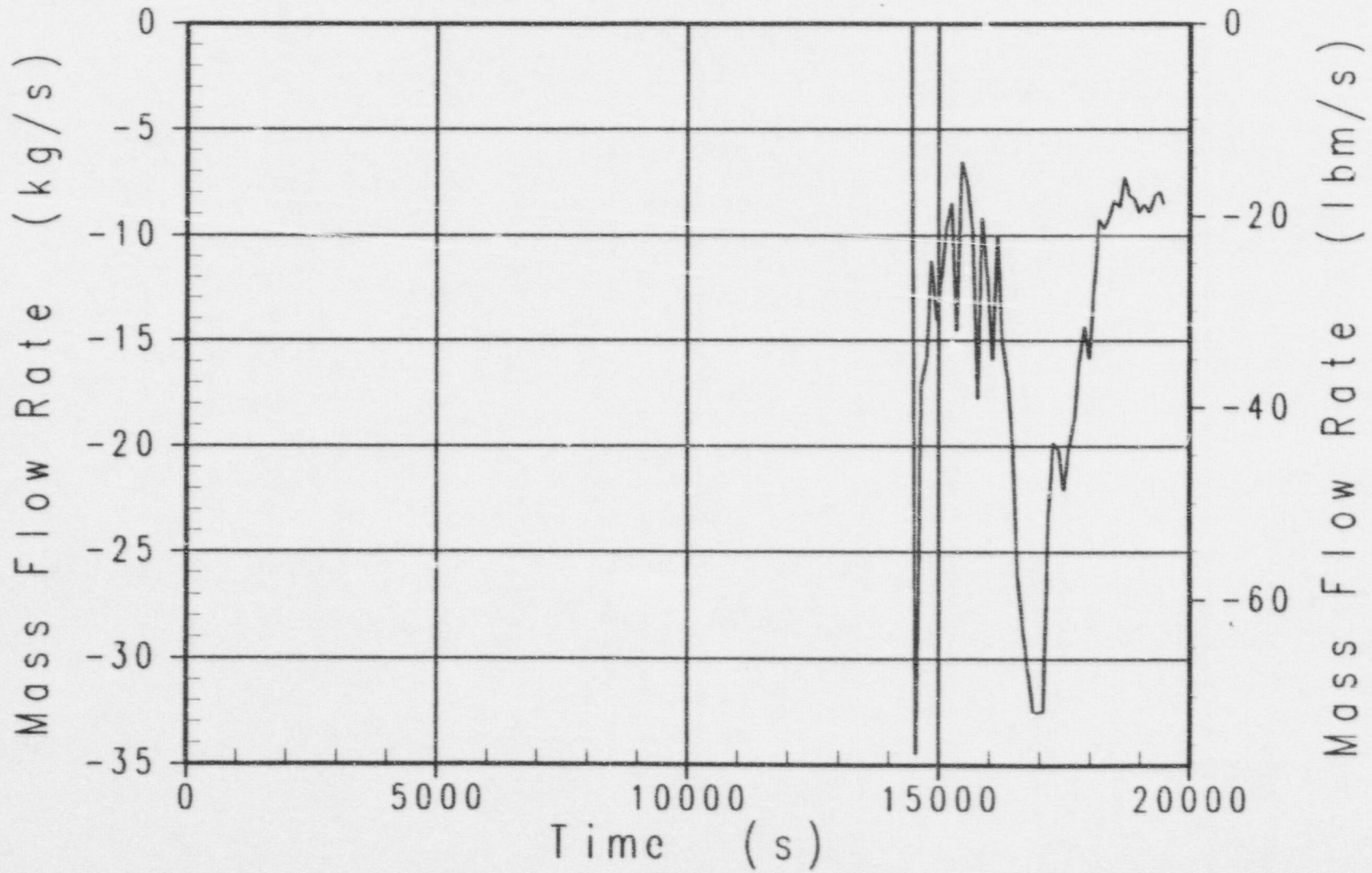

Case s3b2 AP600 Success Criteria MAAP4 Analysis
CMT-1 Injection Flowrate

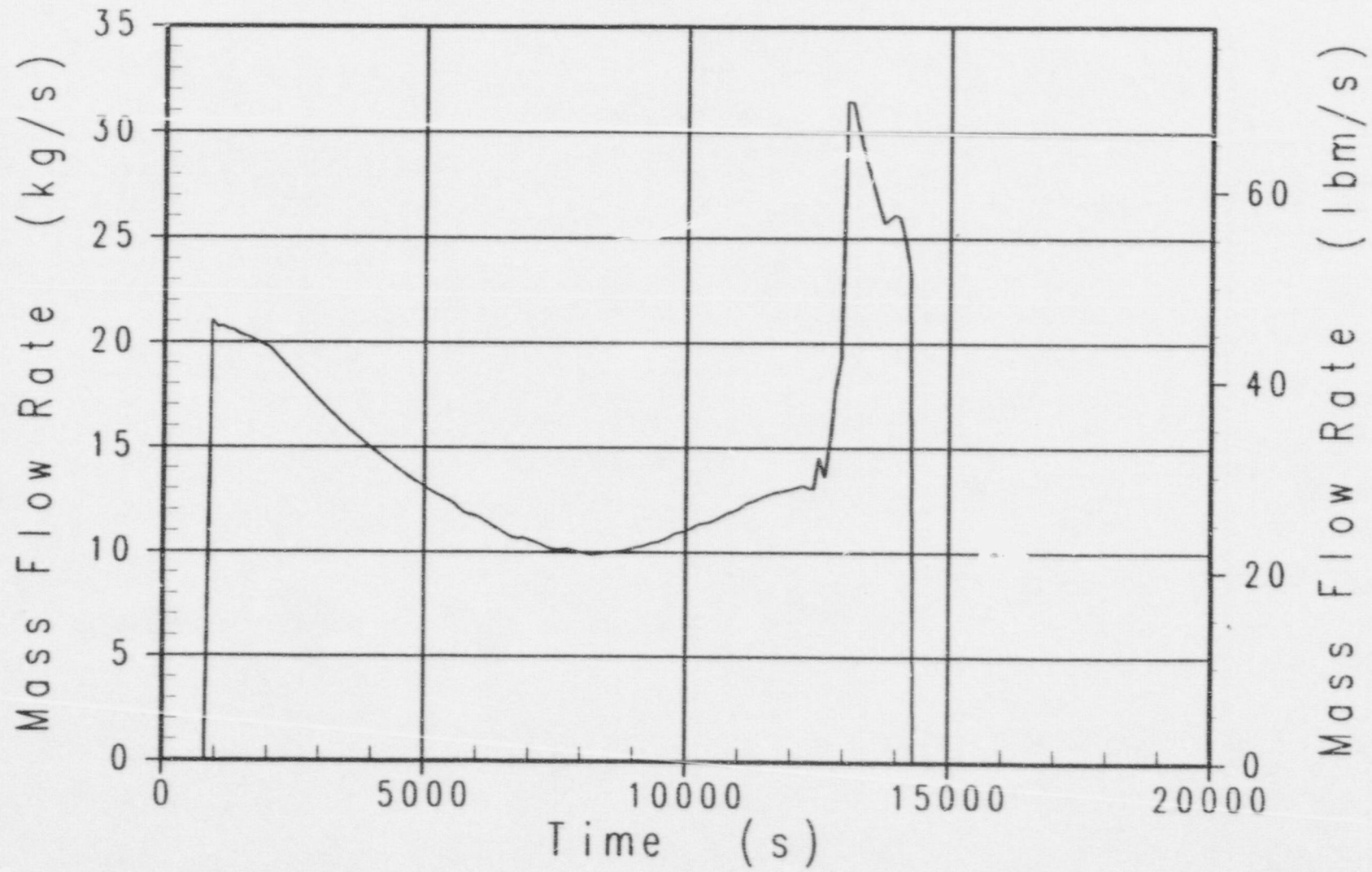

Case s3b2 AP600 Success Criteria MAAp4 Analysis
Safety Valve and ADS Stages 1-3 Liquid Flowrate

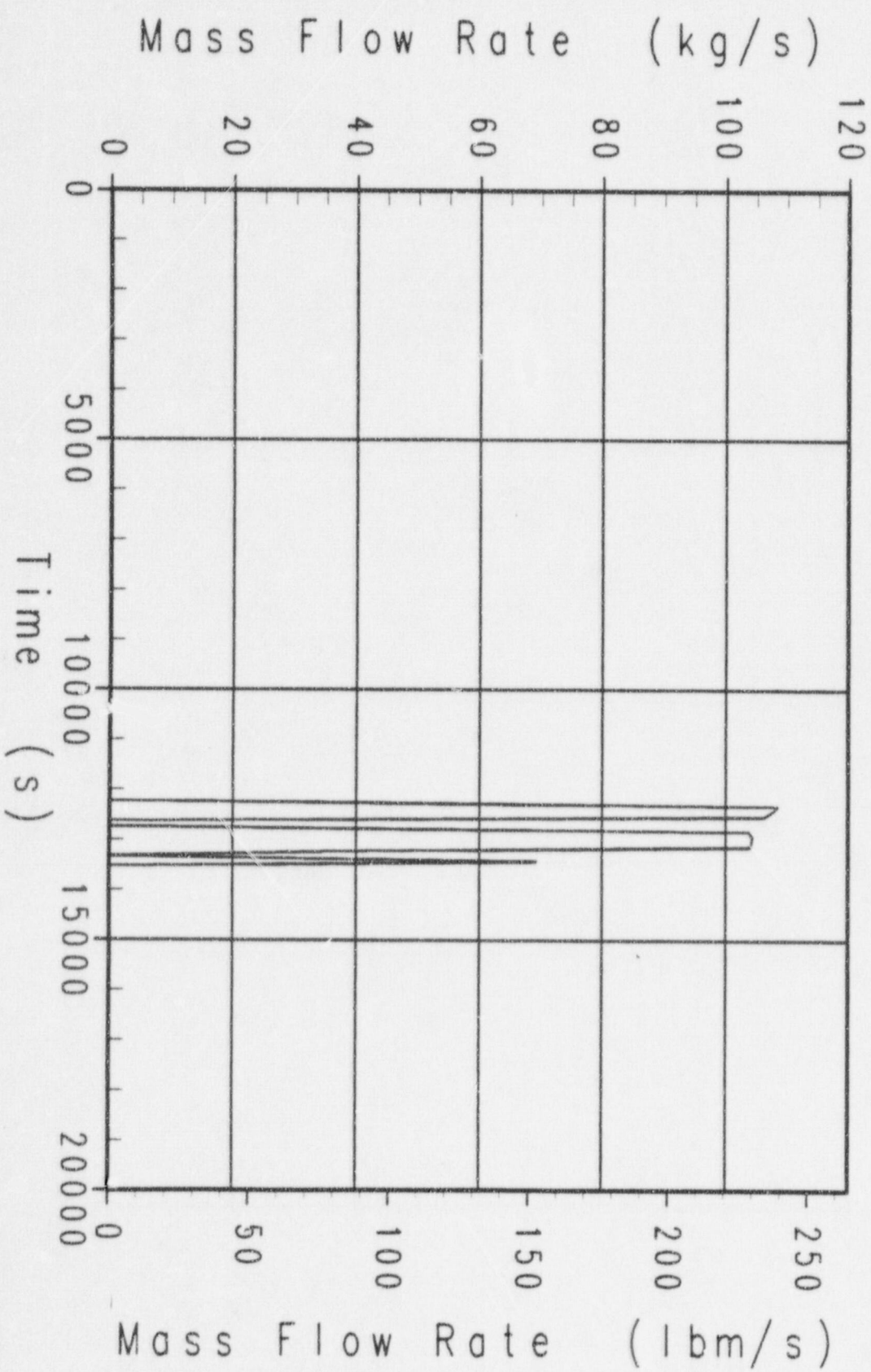

Case s3b2 AP600 Success Criteria MAAP4 Analysis
CMT-1 Water Level

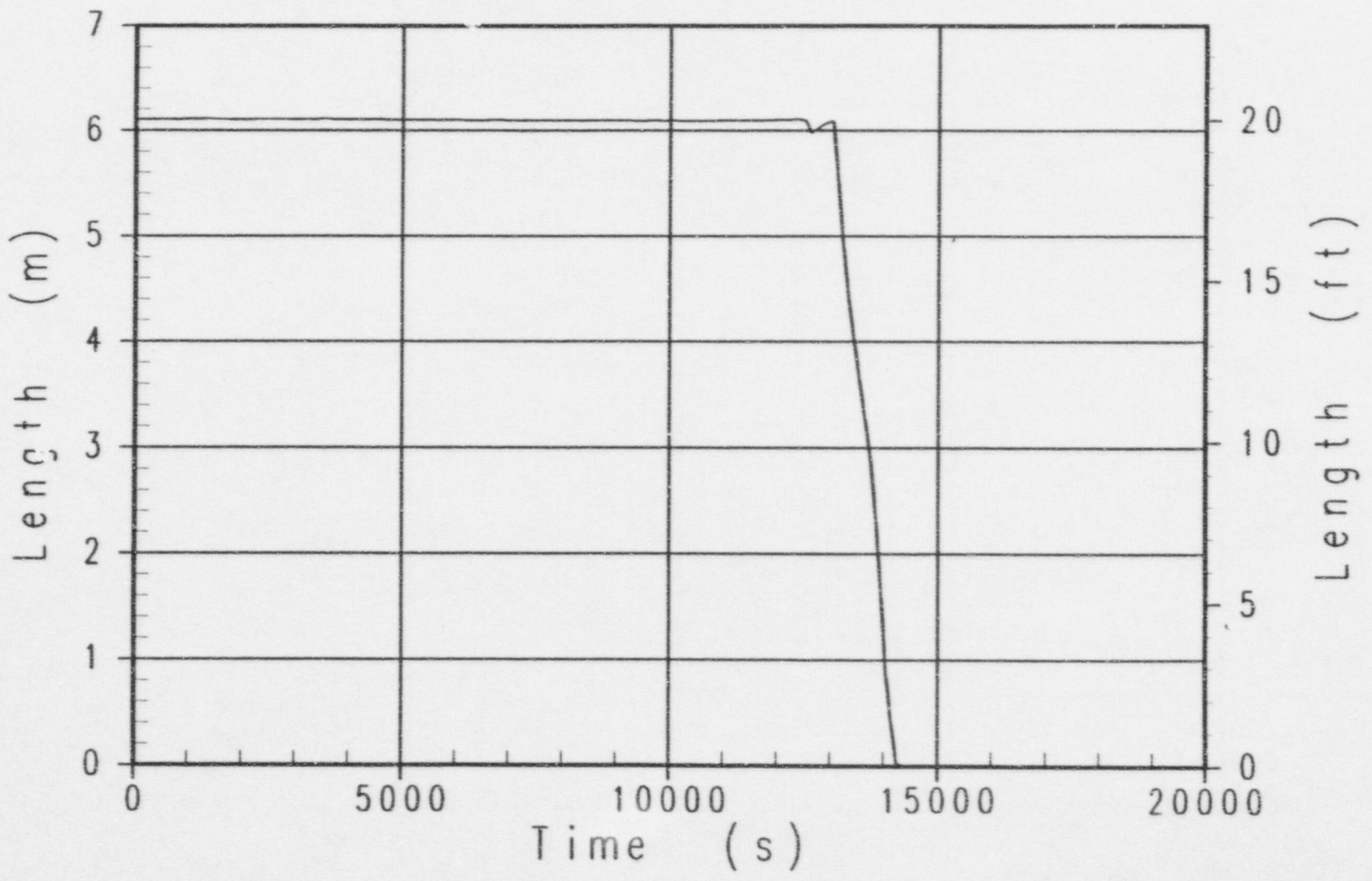

Case s3b2 AP600 Success Criteria MAA4 Analysis
Pressurizer Water Level (From Pzr Bottom)

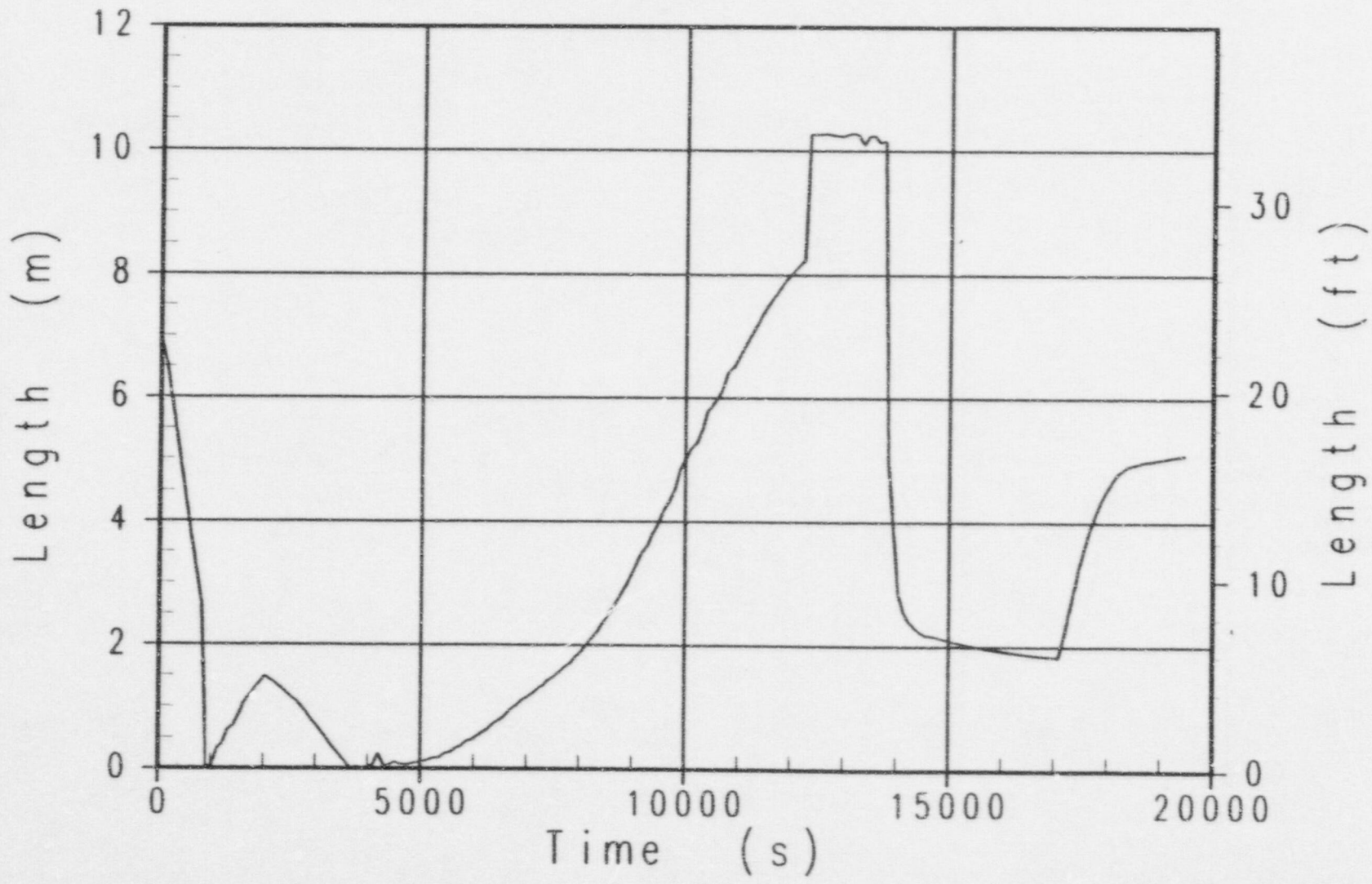

Case s7 AP600 Success Criteria MAA4 Analysis
Broken Loop Steam Generator Pressure

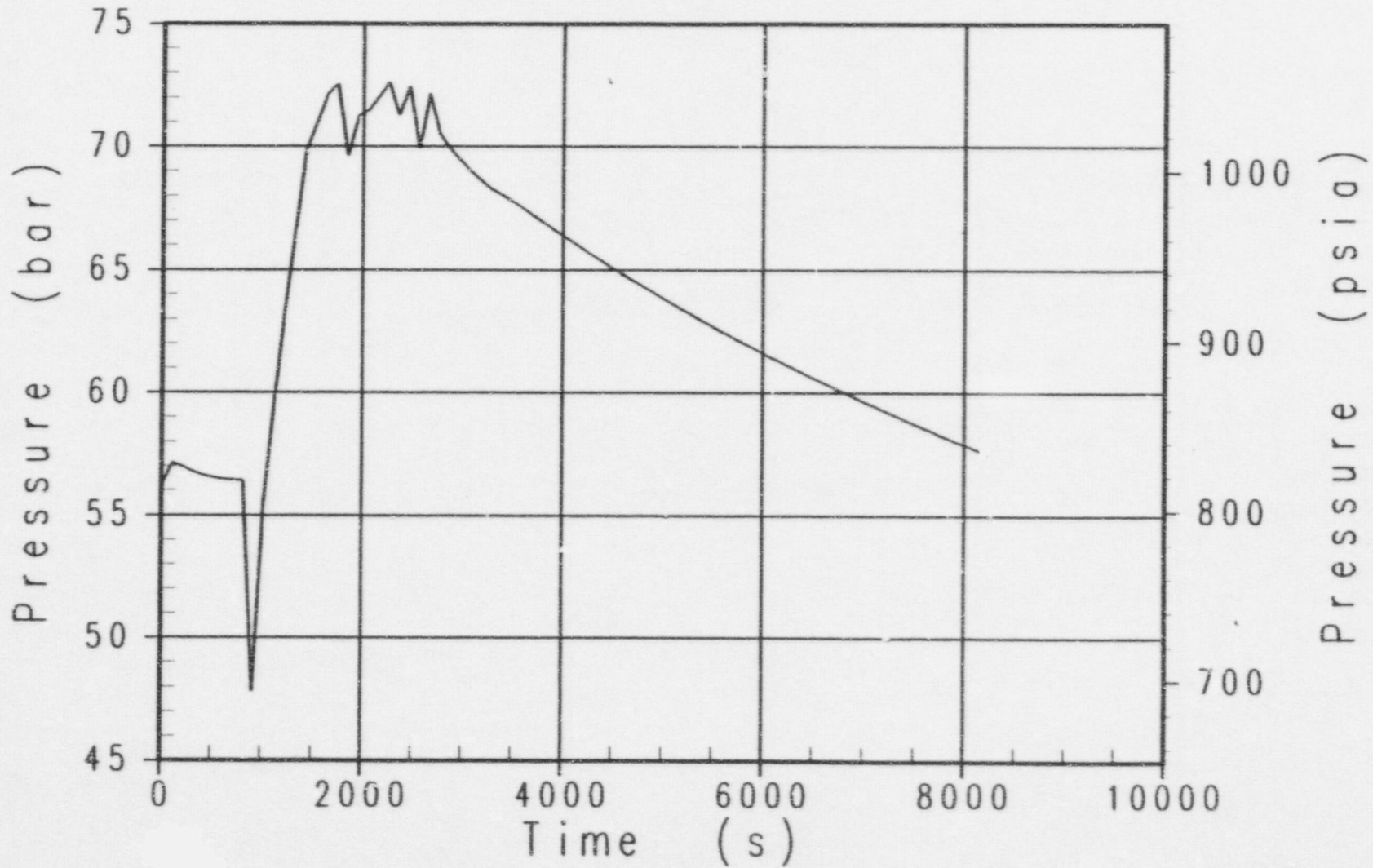

Case s7 AP600 Success Criteria MAAP4 Analysis
Primary System Pressure

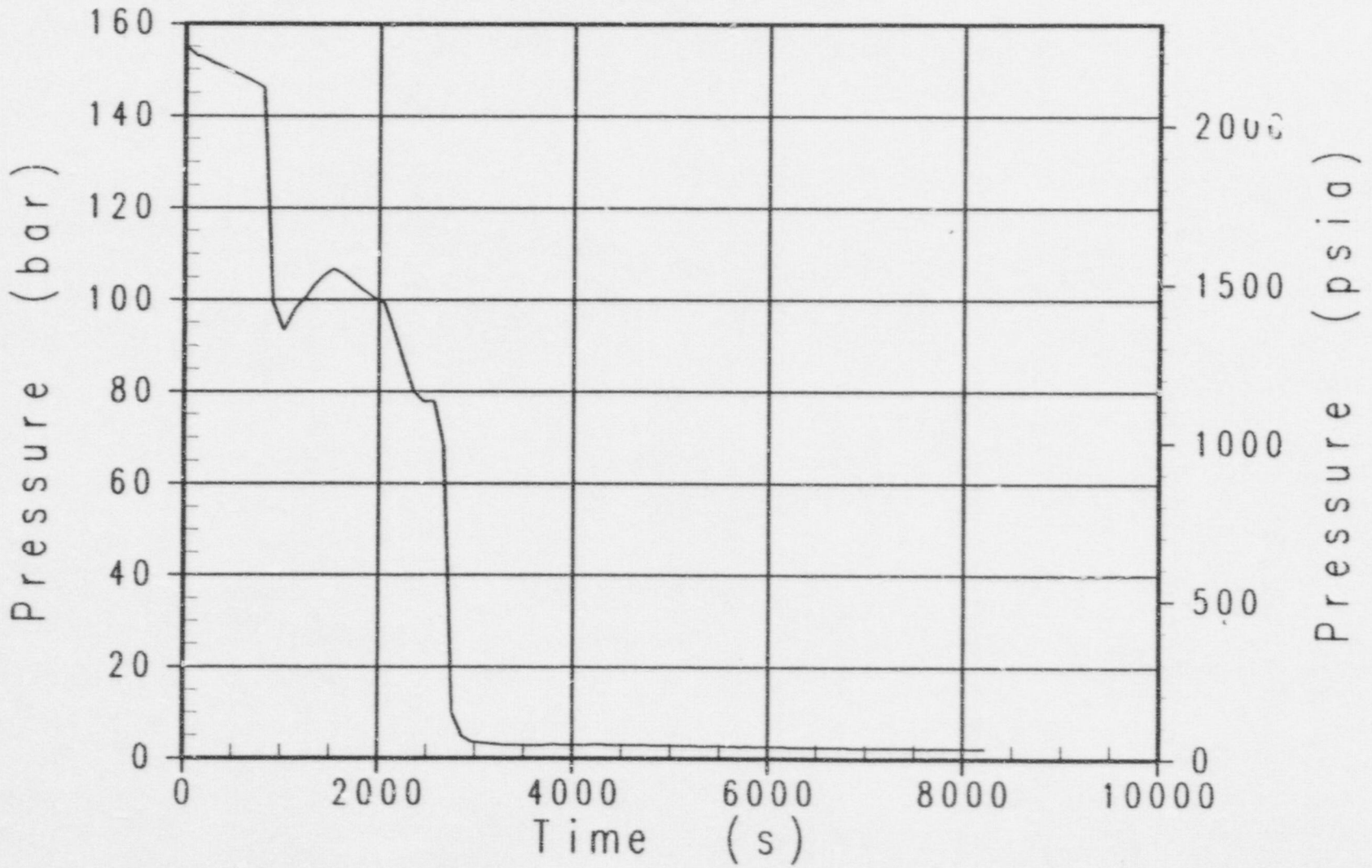

Case s7 AP600 Success Criteria MAAP4 Analysis
Containment Pressure

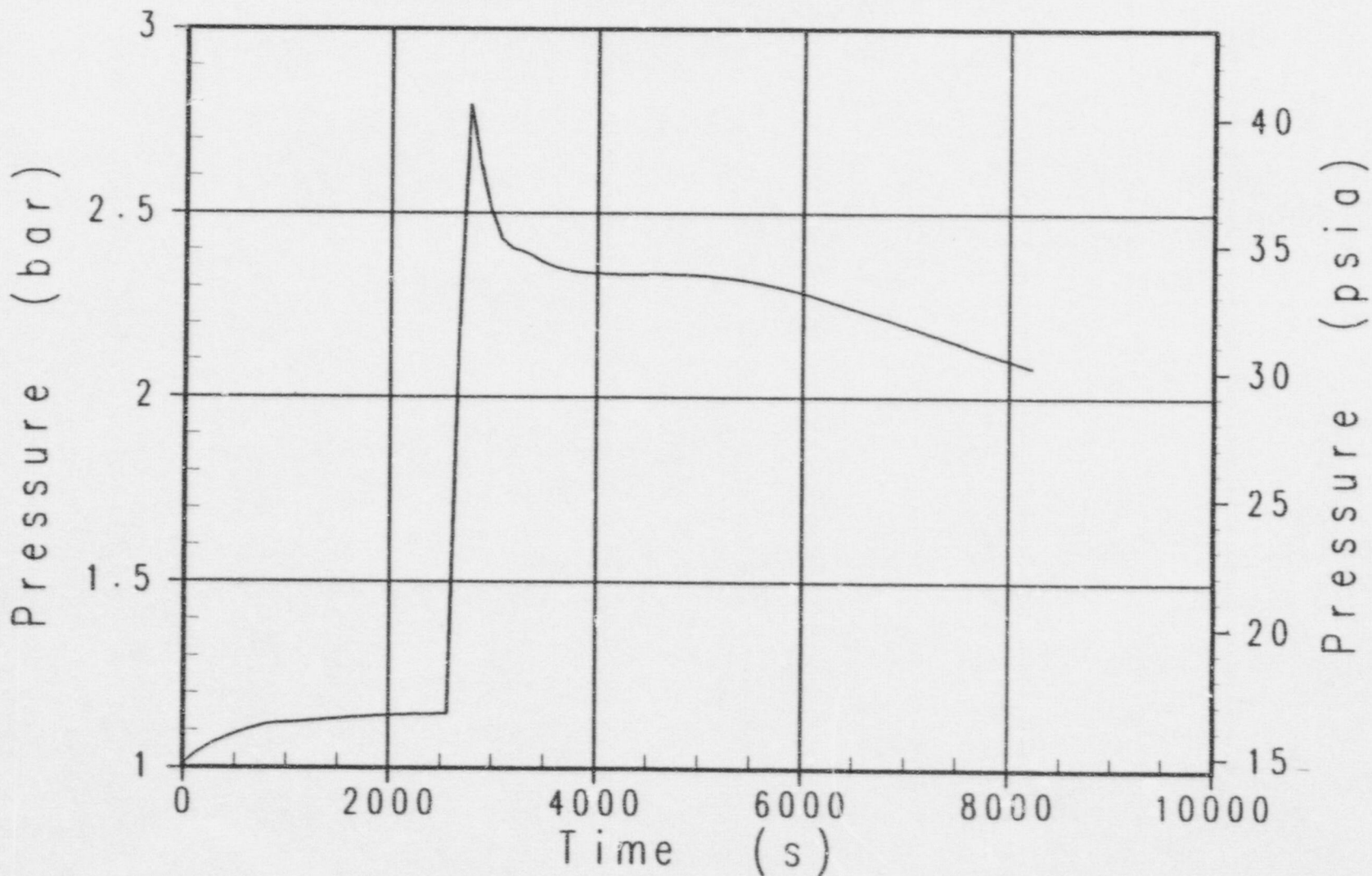

Case s7 AP600 Success Criteria MAAP4 Analysis
Unbroken Loop Steam Generator Pressure

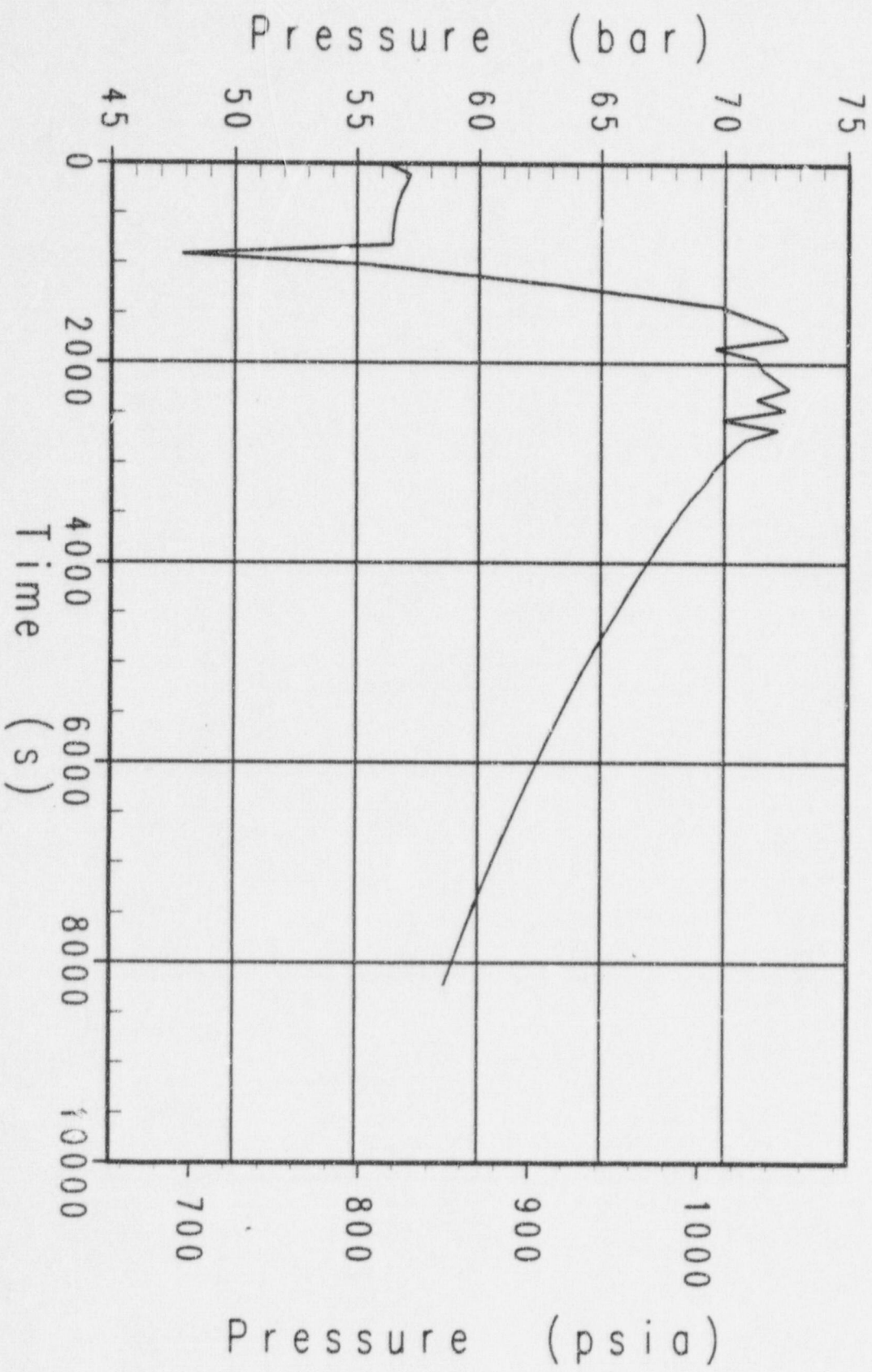

Case s7 AP600 Success Criteria MAAP4 Analysis
Decay Power

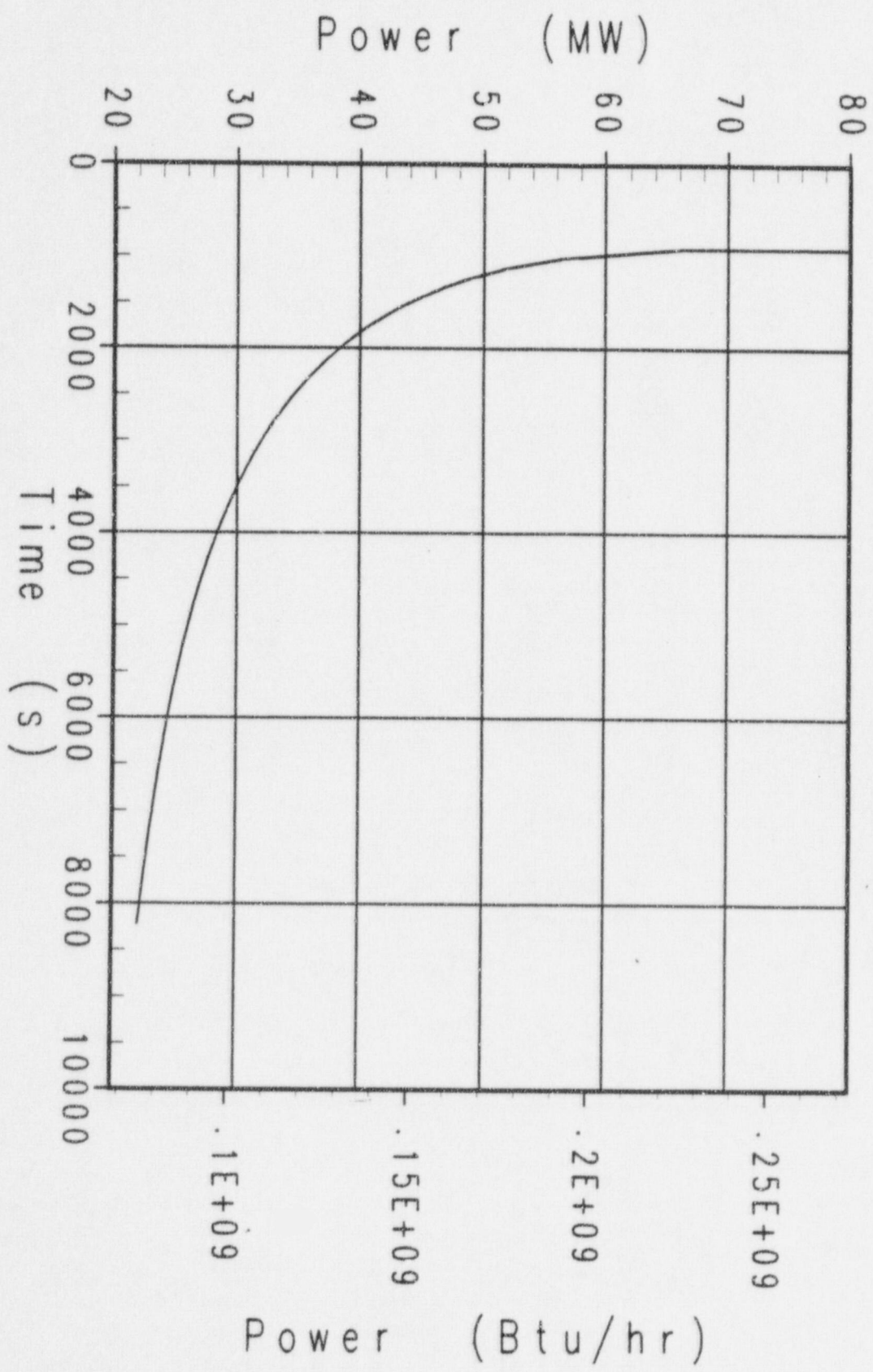

Case s7 AP600 Success Criteria MAAP4 Analysis
PRHR Heat Removal Rate

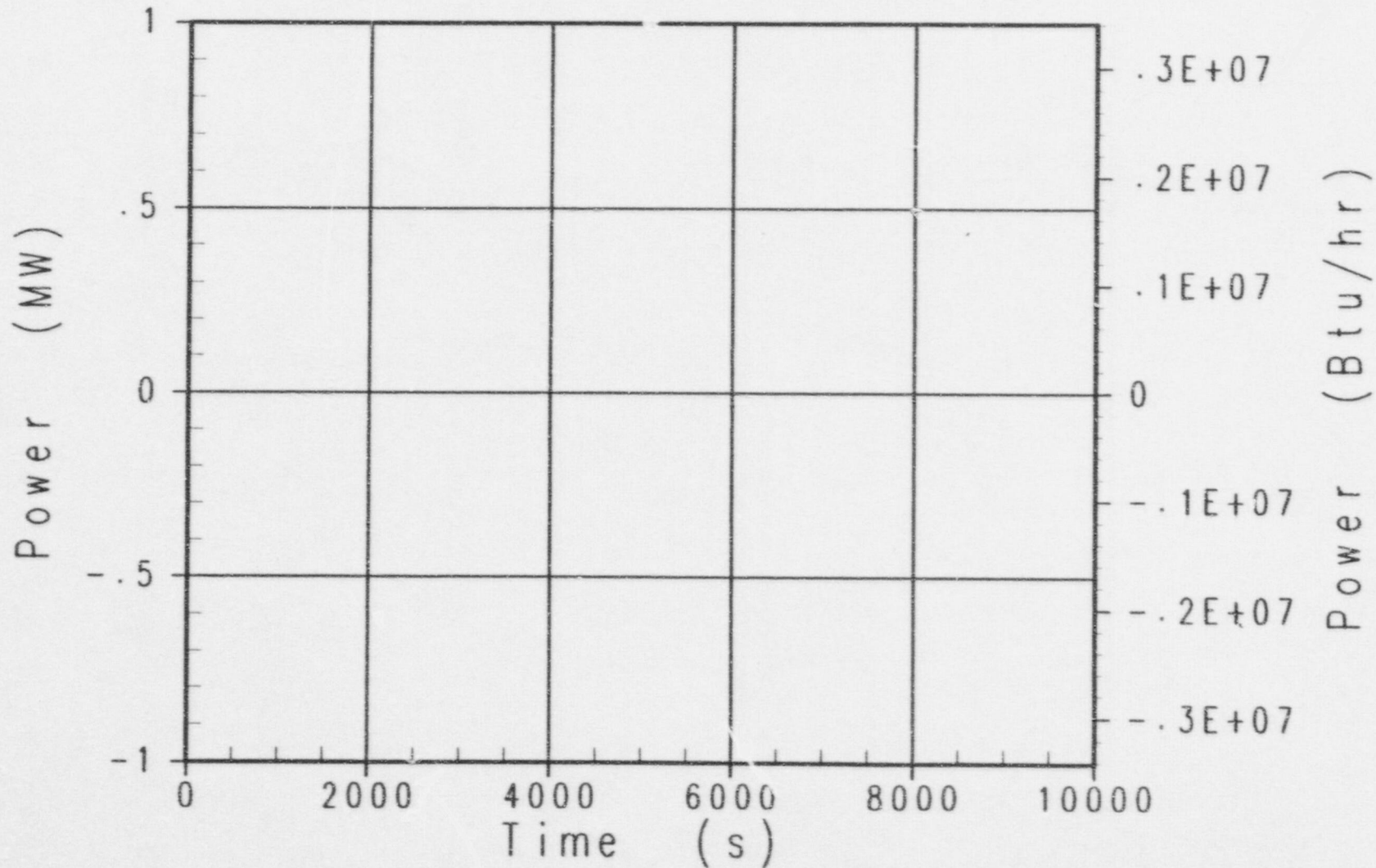

Case s7 AP600 Success Criteria MAAP4 Analysis
Peak Temperature in the Core

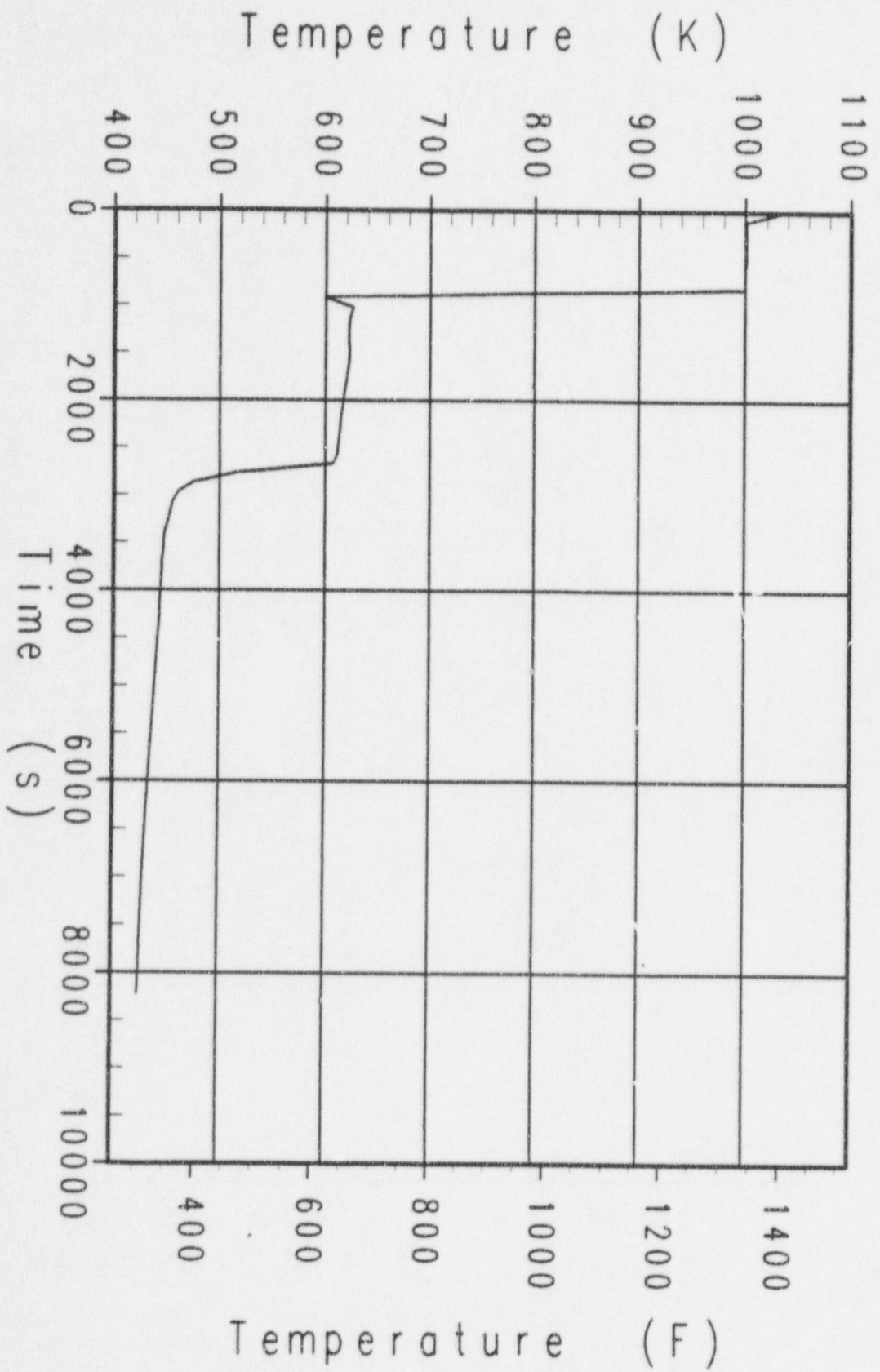

Case s7 AP600 Success Criteria MAAP4 Analysis
Cold Leg Water Temperature

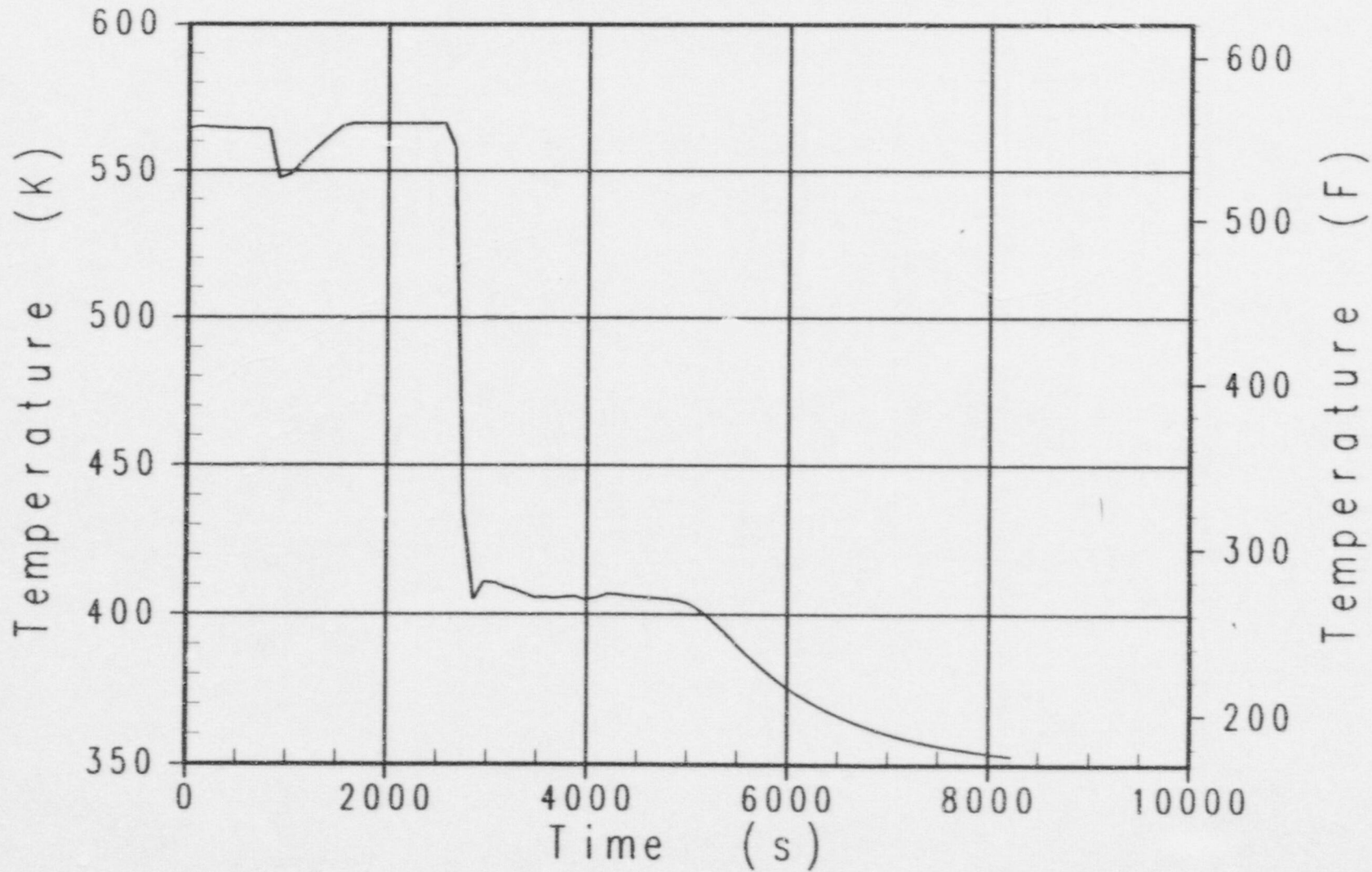

Case s7 AP600 Success Criteria MAAP4 Analysis
Core Water Temperature

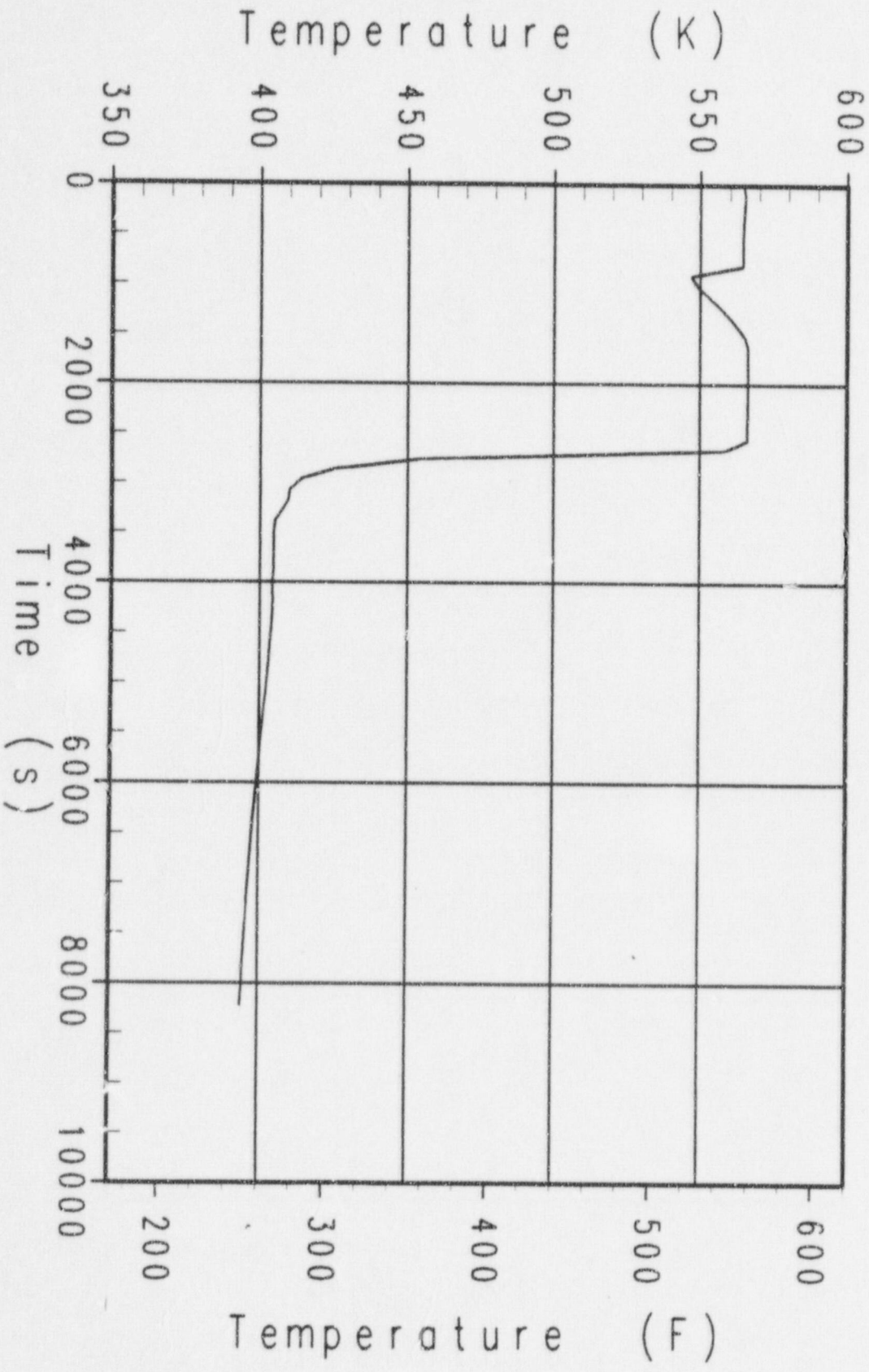

Case s7 AP600 Success Criteria MAAp4 Analysis
RPV Downcomer Water Temperature

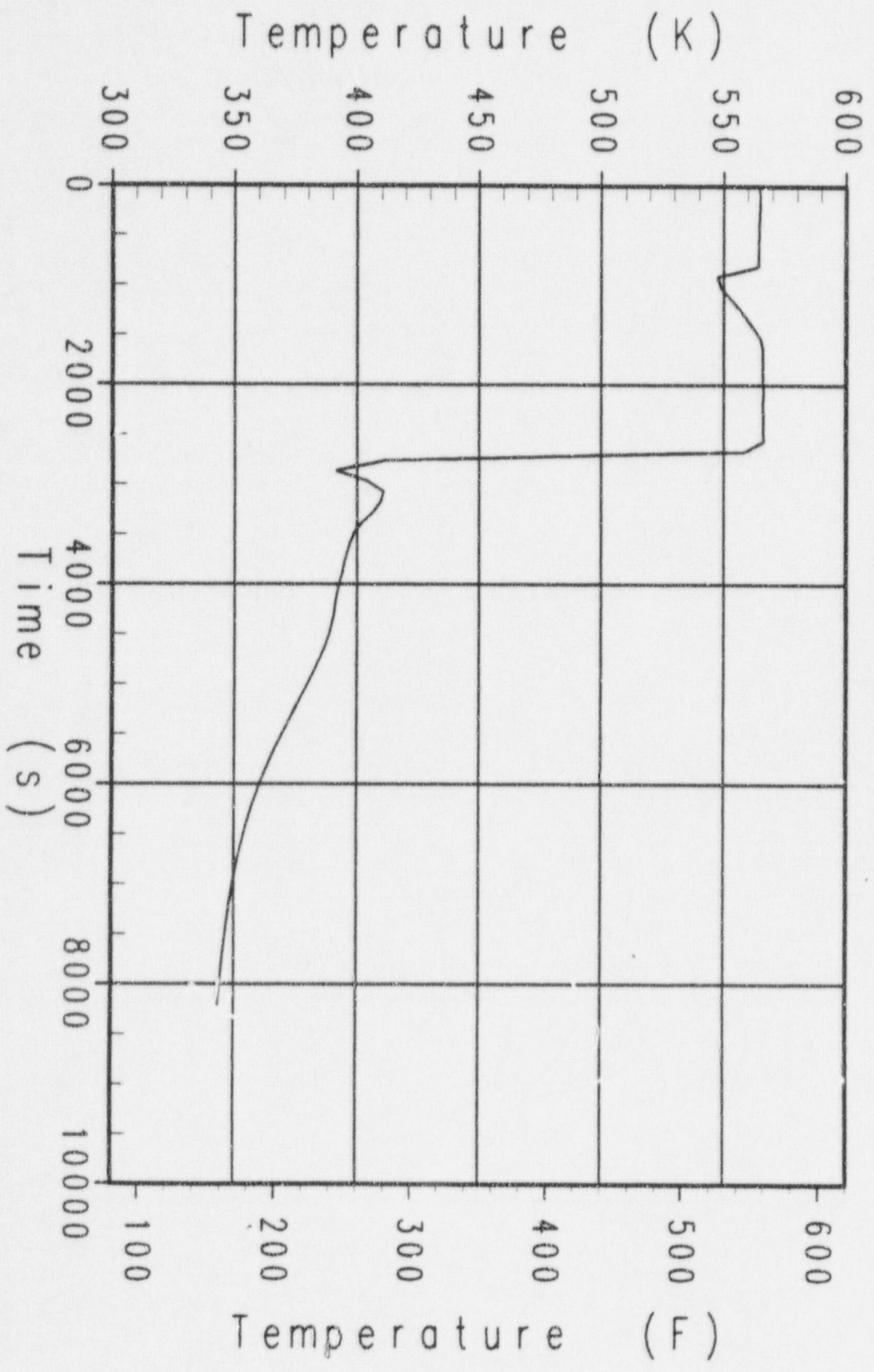

Case s7 AP600 Success Criteria MAAP4 Analysis
IRWST Water Temperature

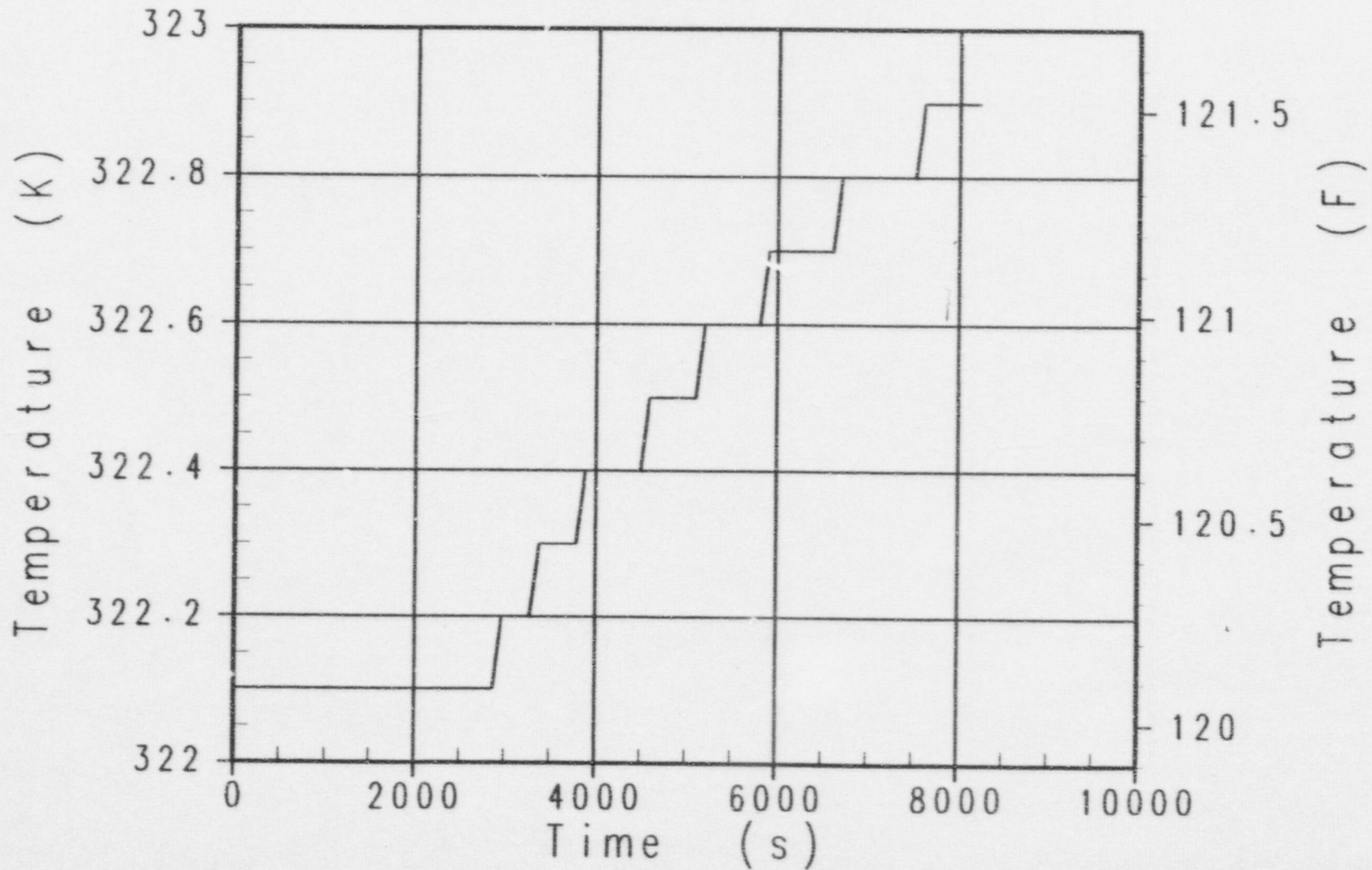

Case s7 AP600 Success Criteria MAAP4 Analysis
Accumulator and NRHR Injection Flowrate

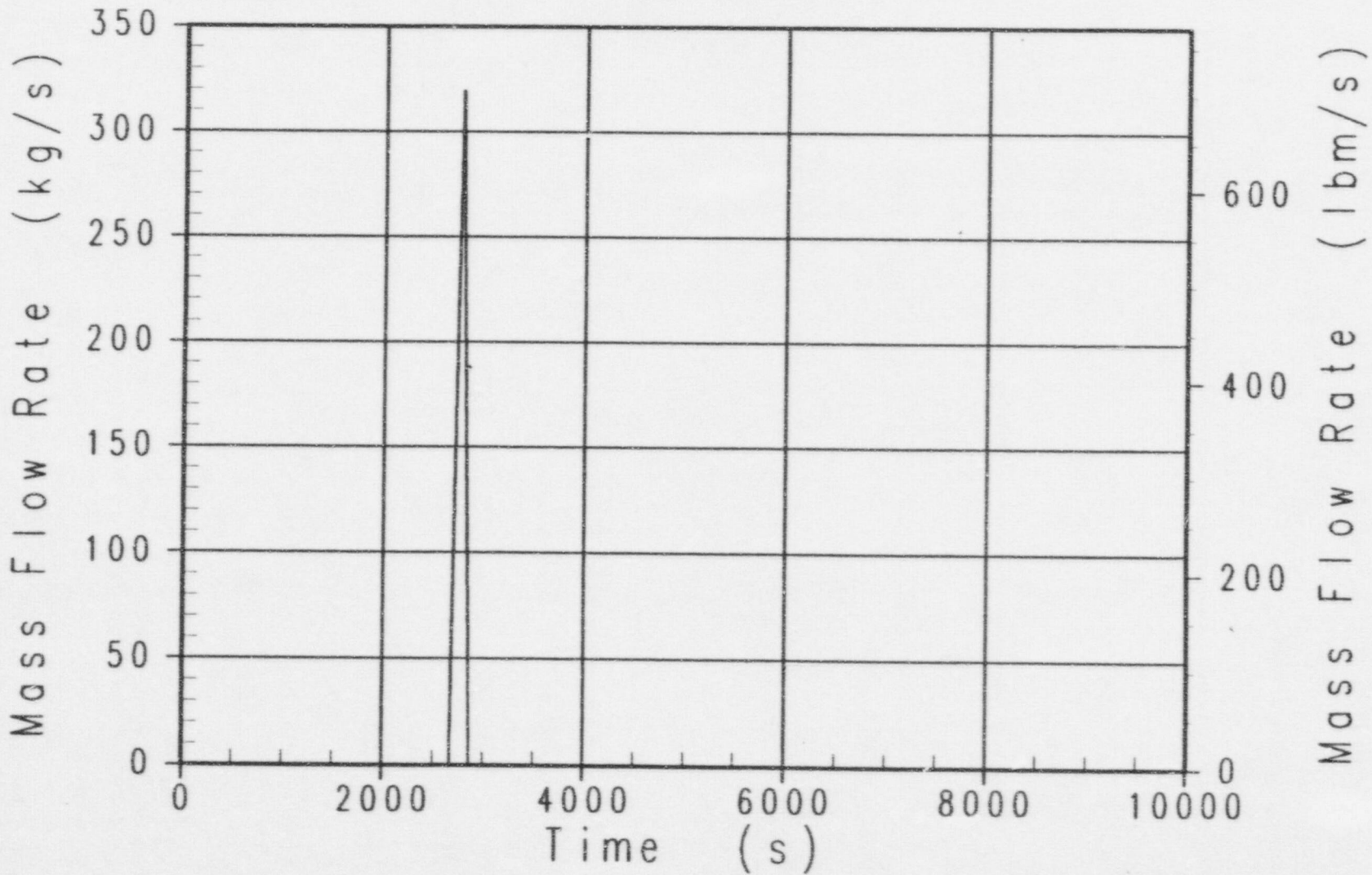

Case s7 AP600 Success Criteria MAAP4 Analysis
RCS Break Gas Flowrate

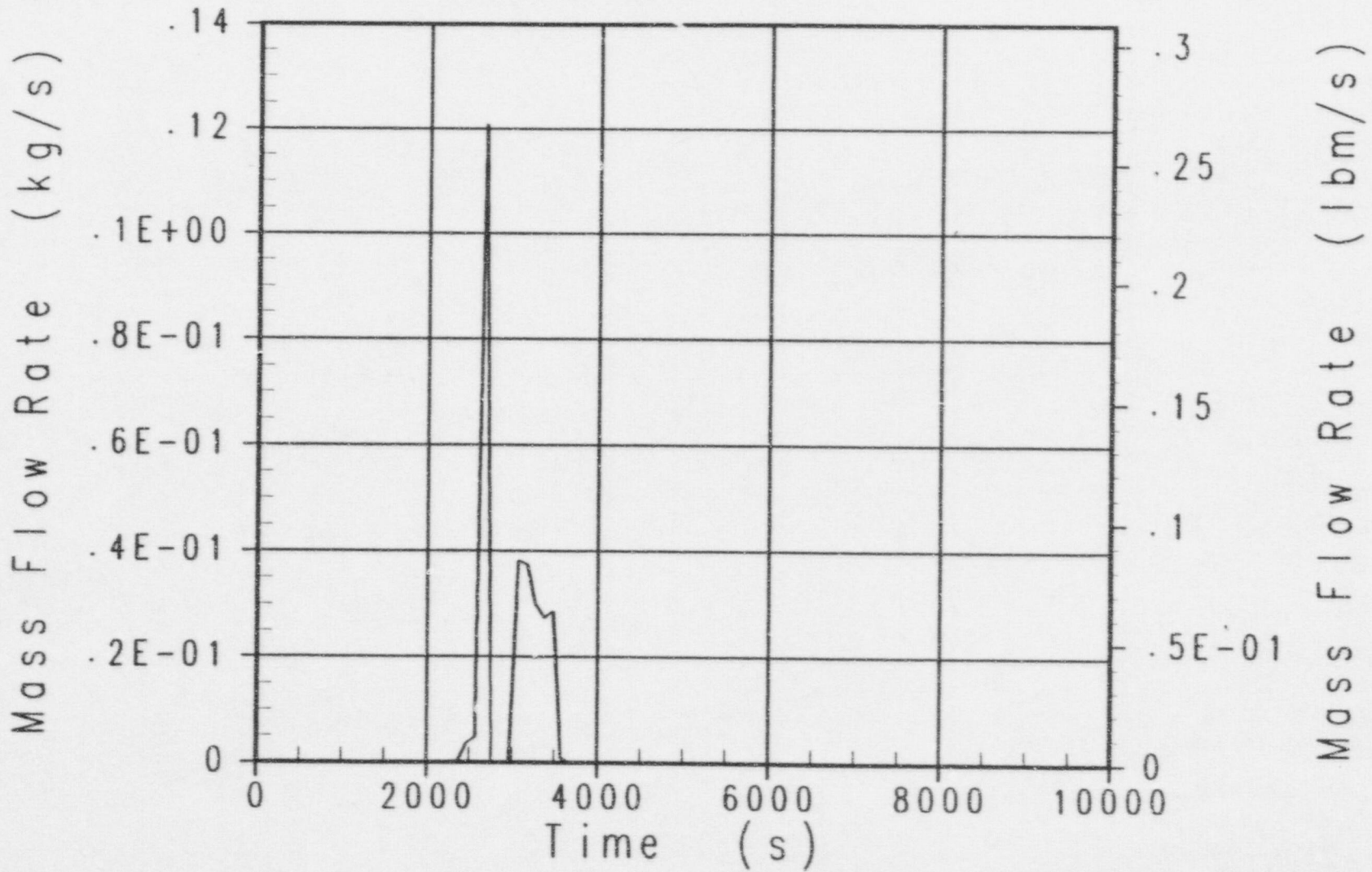

Case s7 AP600 Success Criteria MAPP4 Analysis
ADS Stage 4 Gas Flowrate

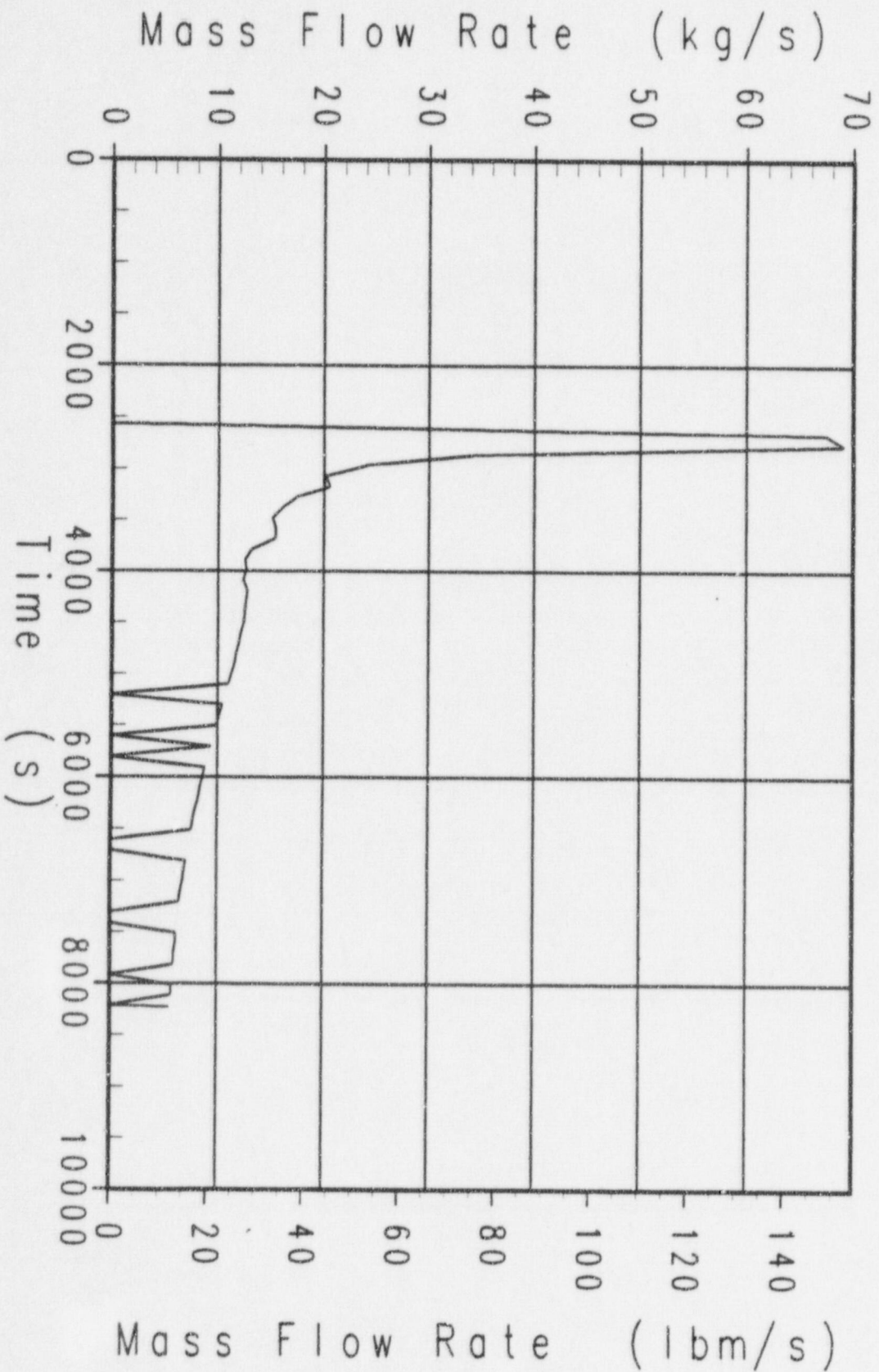

Case s7 AP600 Success Criteria MAAP4 Analysis
Safety Valve and ADS Stages 1-3 Gas Flowrate

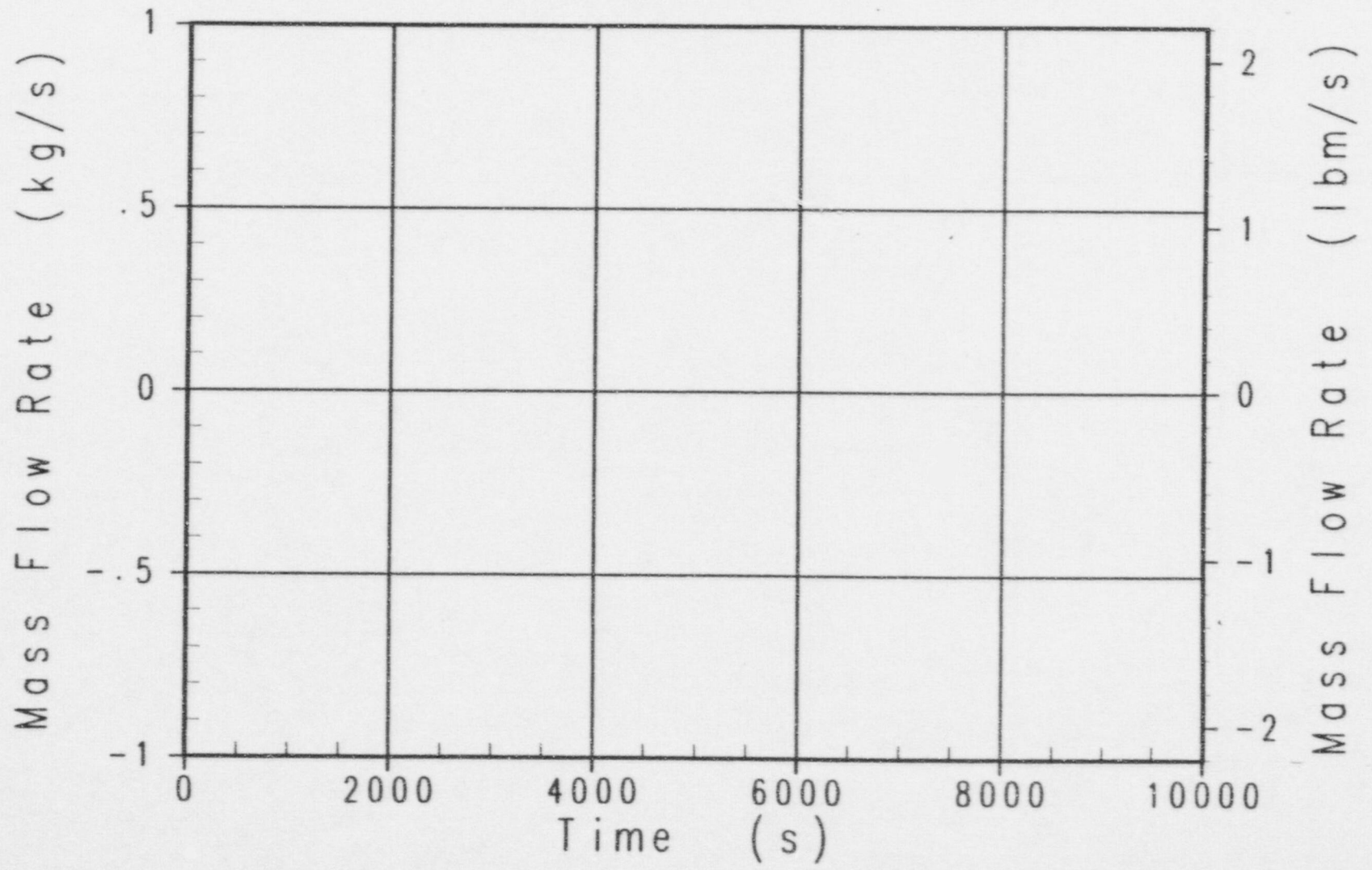

Case s7 AP600 Success Criteria MAAP4 Analysis
RCS Break Liquid Flowrate

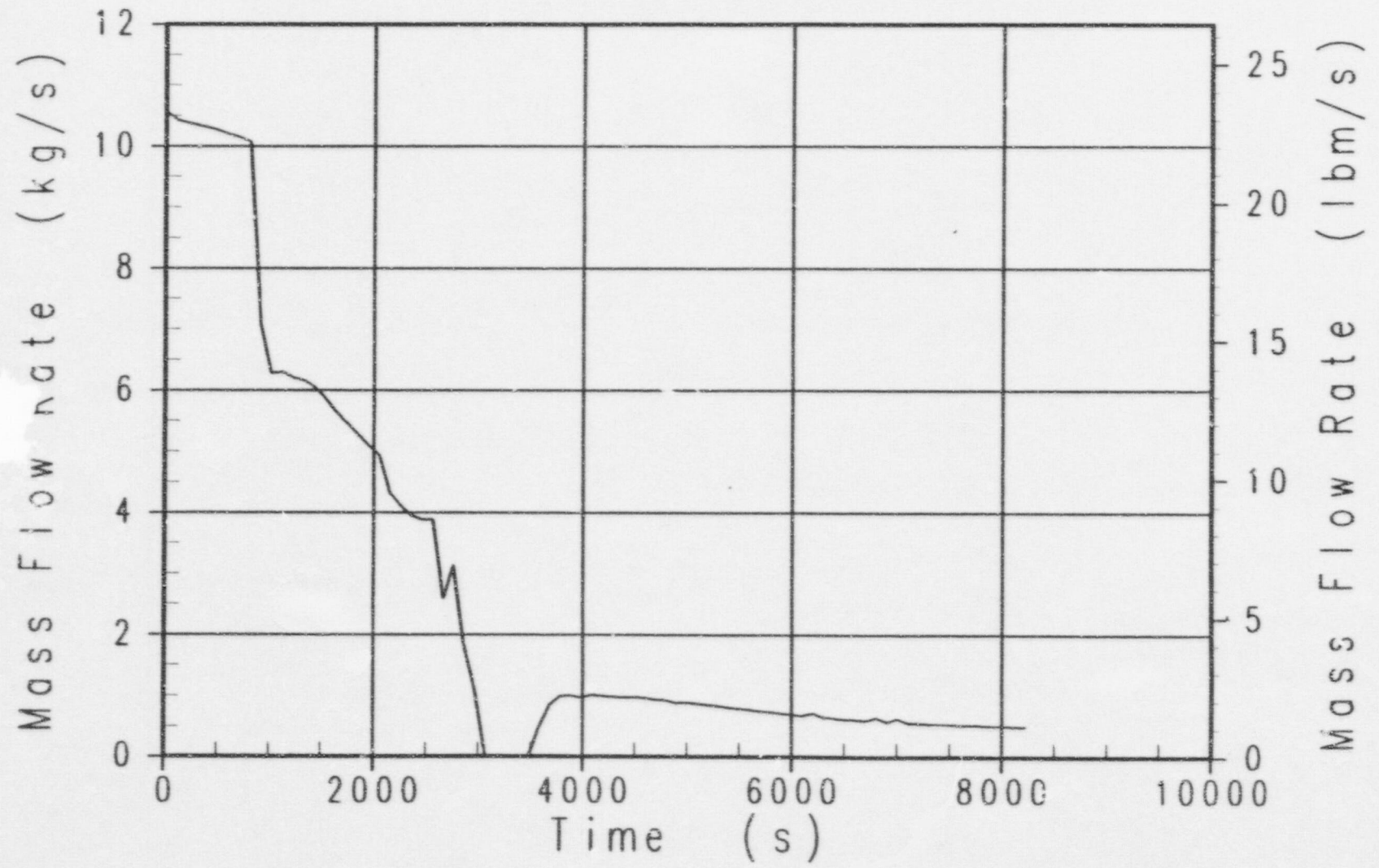

Case s7 AP600 Success Criteria MAAP4 Analysis
ADS Stage 4 Liquid Flowrate

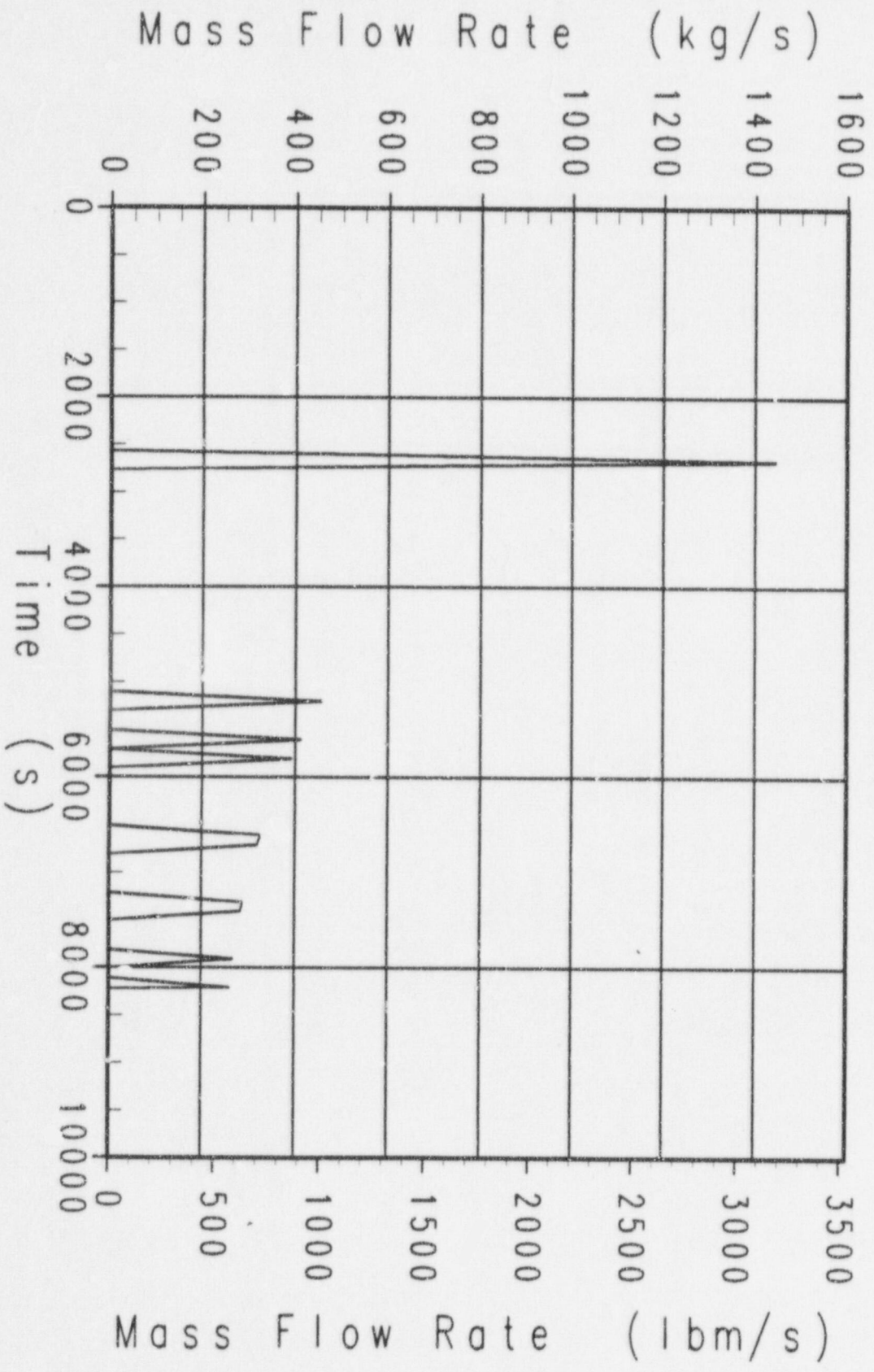

Case s7 AP600 Success Criteria MAAP4 Analysis
IRWST Injection Flowrate (neg. means into RCS)

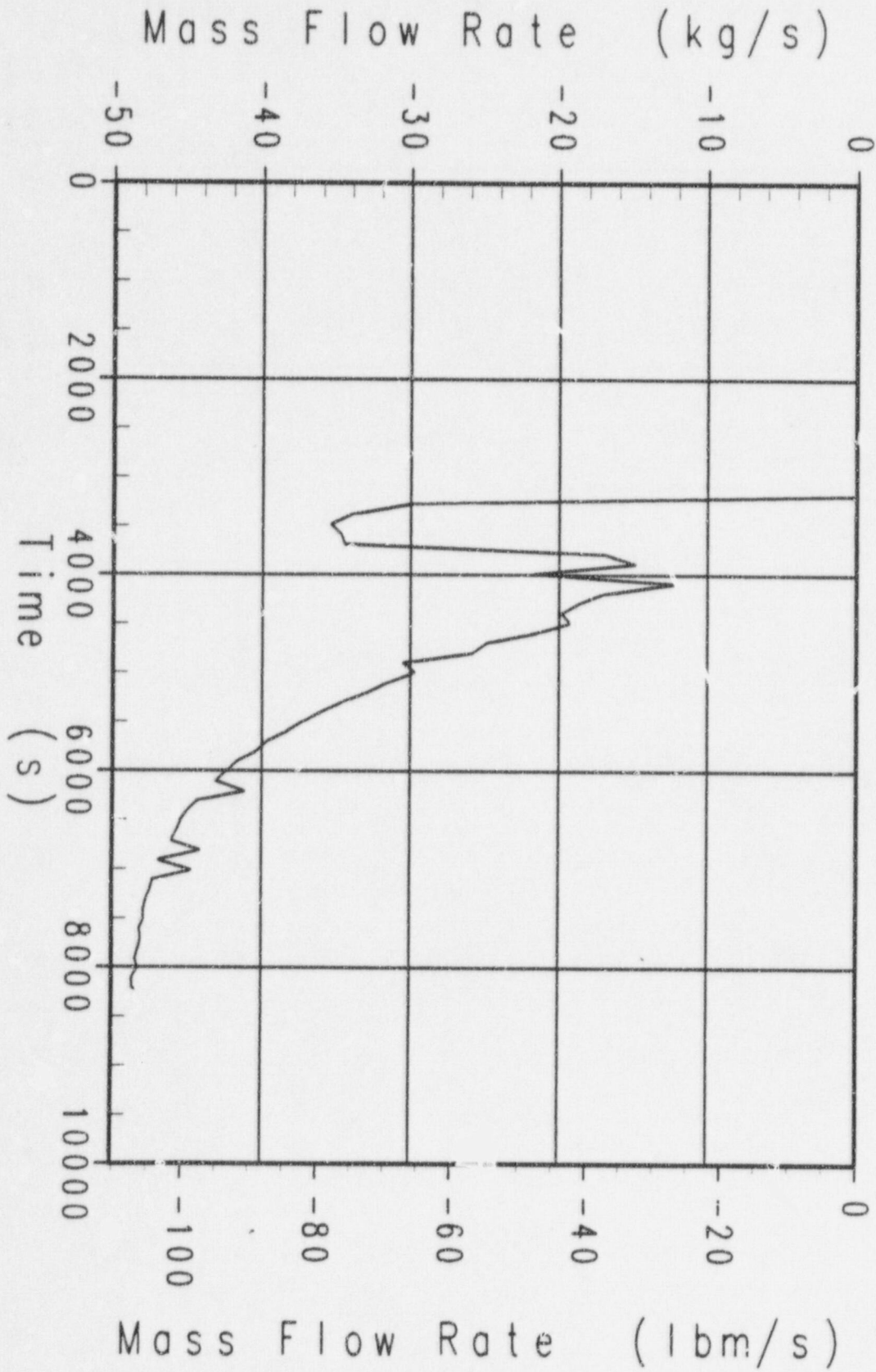

Case s7 AP600 Success Criteria MAAP4 Analysis
CMT-1 Injection Flowrate

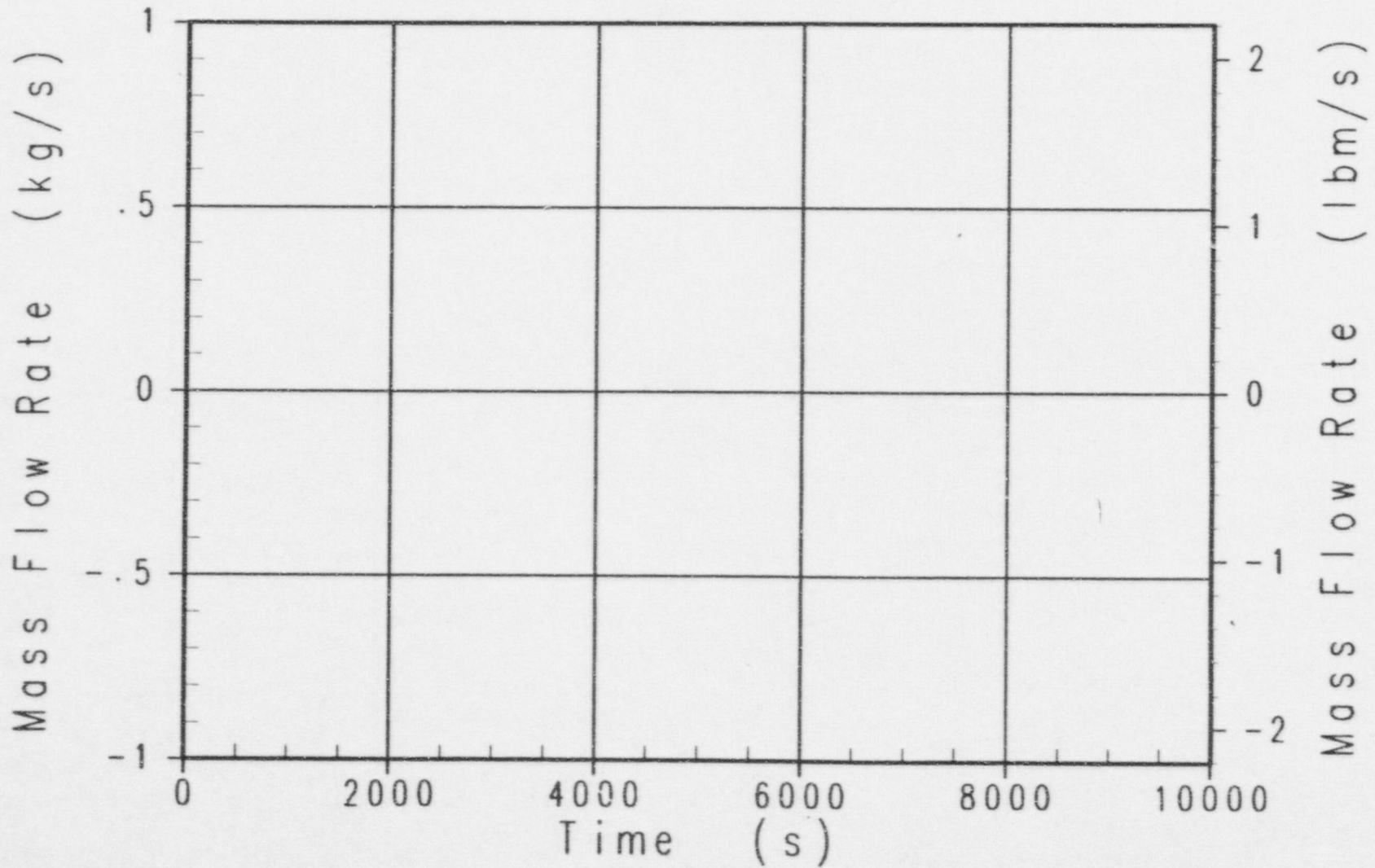

Case s7 AP600 Success Criteria MAPP4 Analysis
Safety Valve and ADS Stages 1-3 Liquid Flowrate

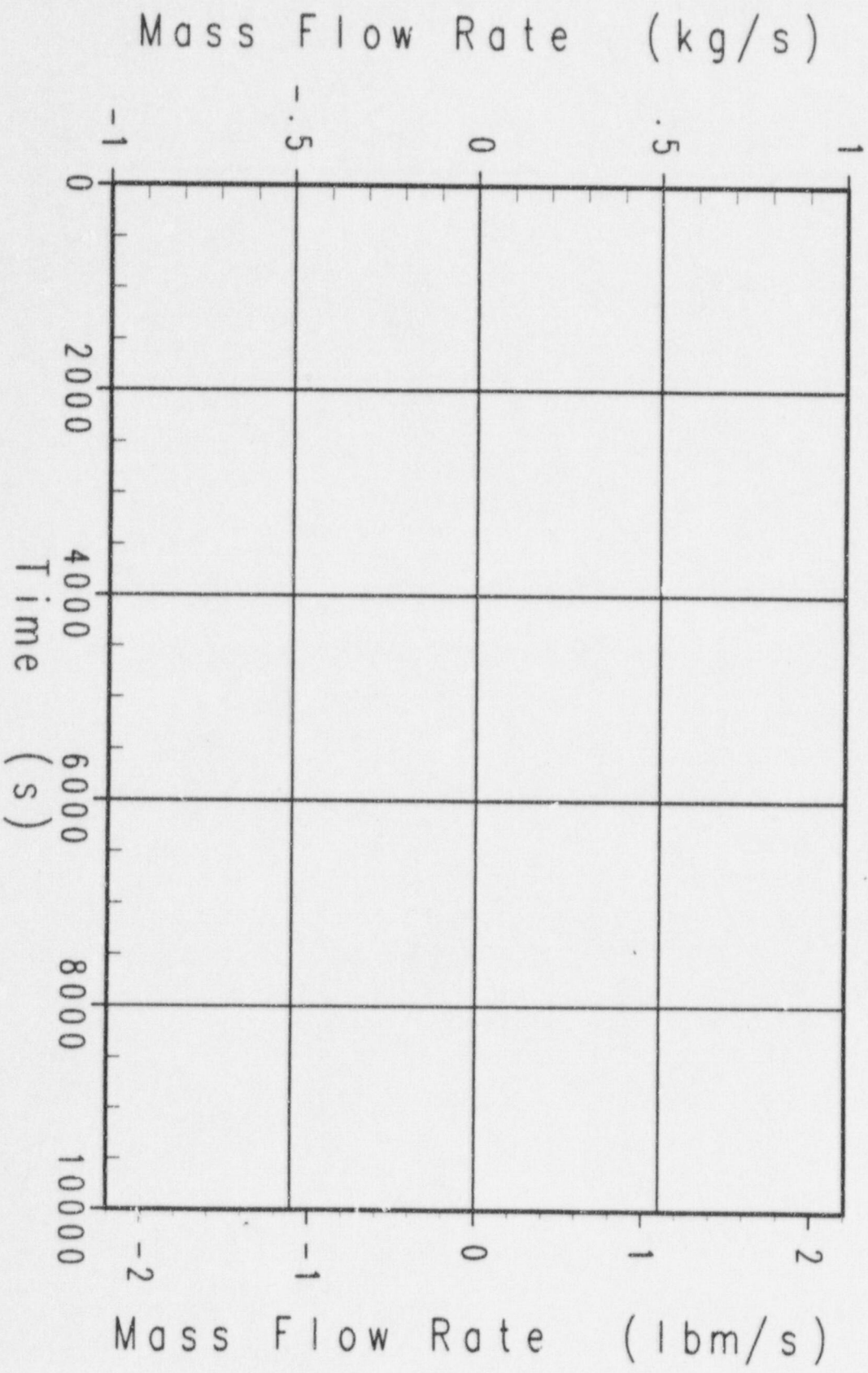

Case s7 AP600 Success Criteria MAAP4 Analysis
CMT-1 Water Level

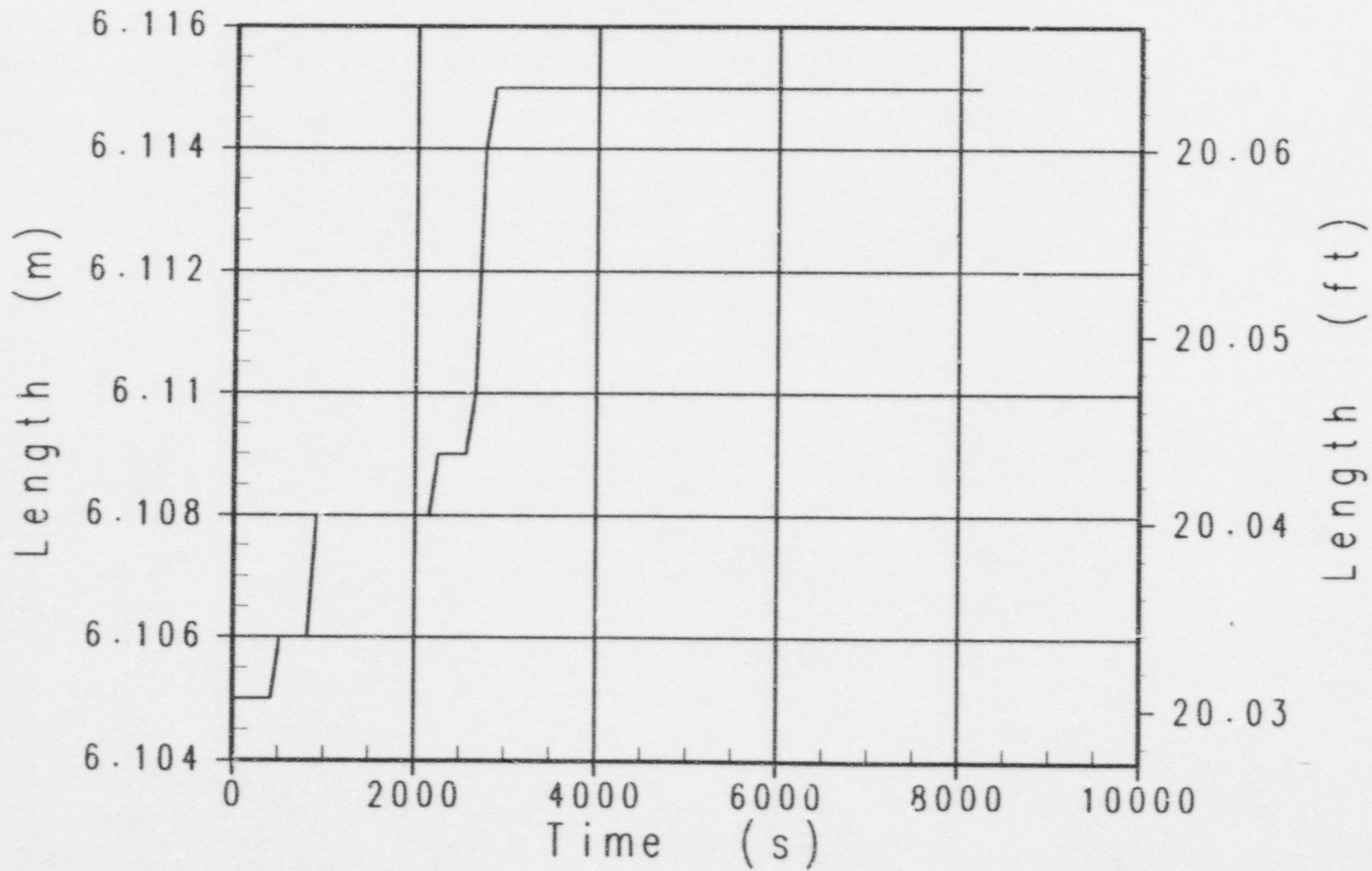

Case s7 AP600 Success Criteria MAAP4 Analysis
Pressurizer Water Level (From Pzr Bottom)

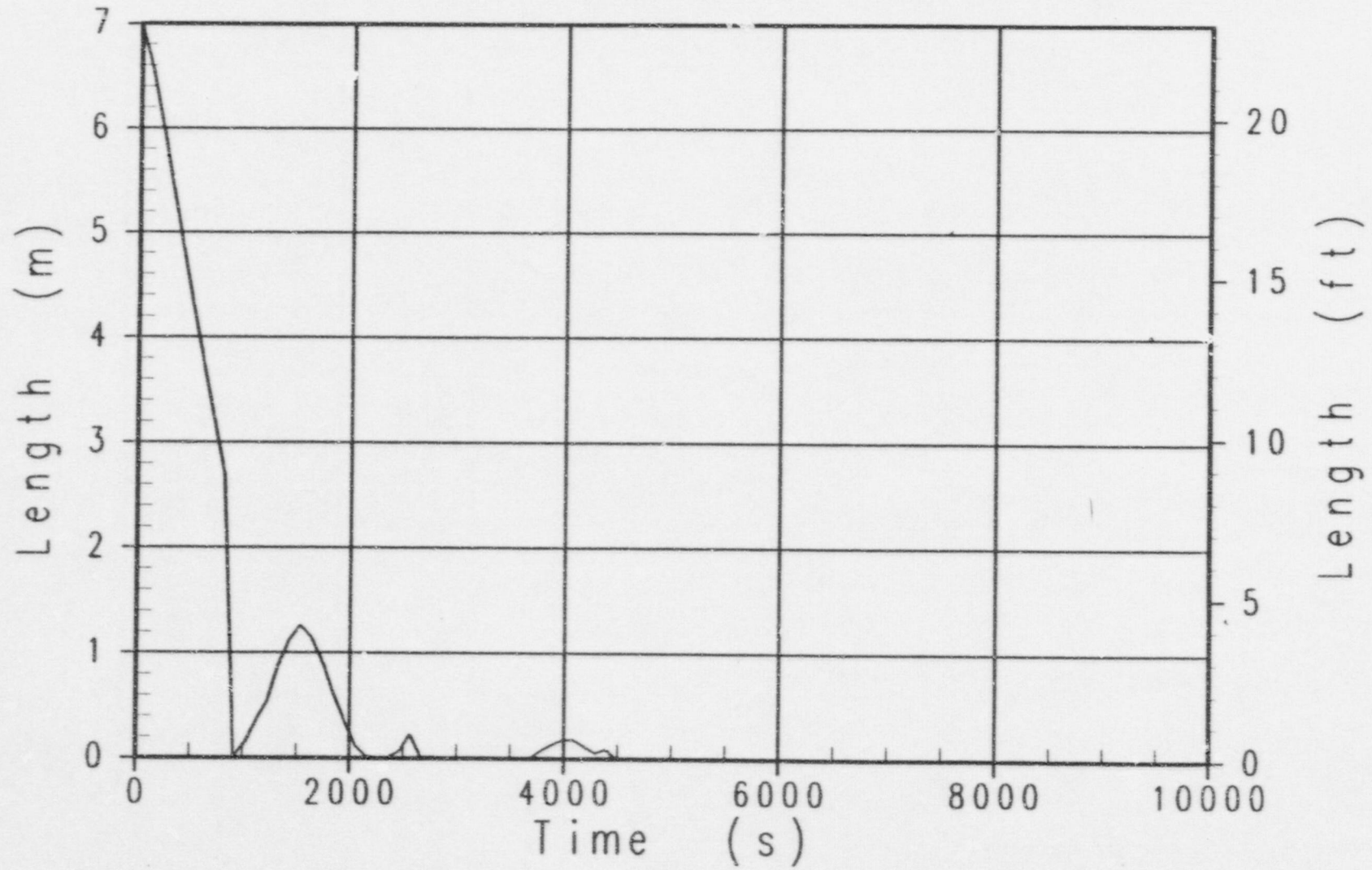

Case 91a AP600 Success Criteria MAP4 Analysis
Broken Loop Steam Generator Pressure

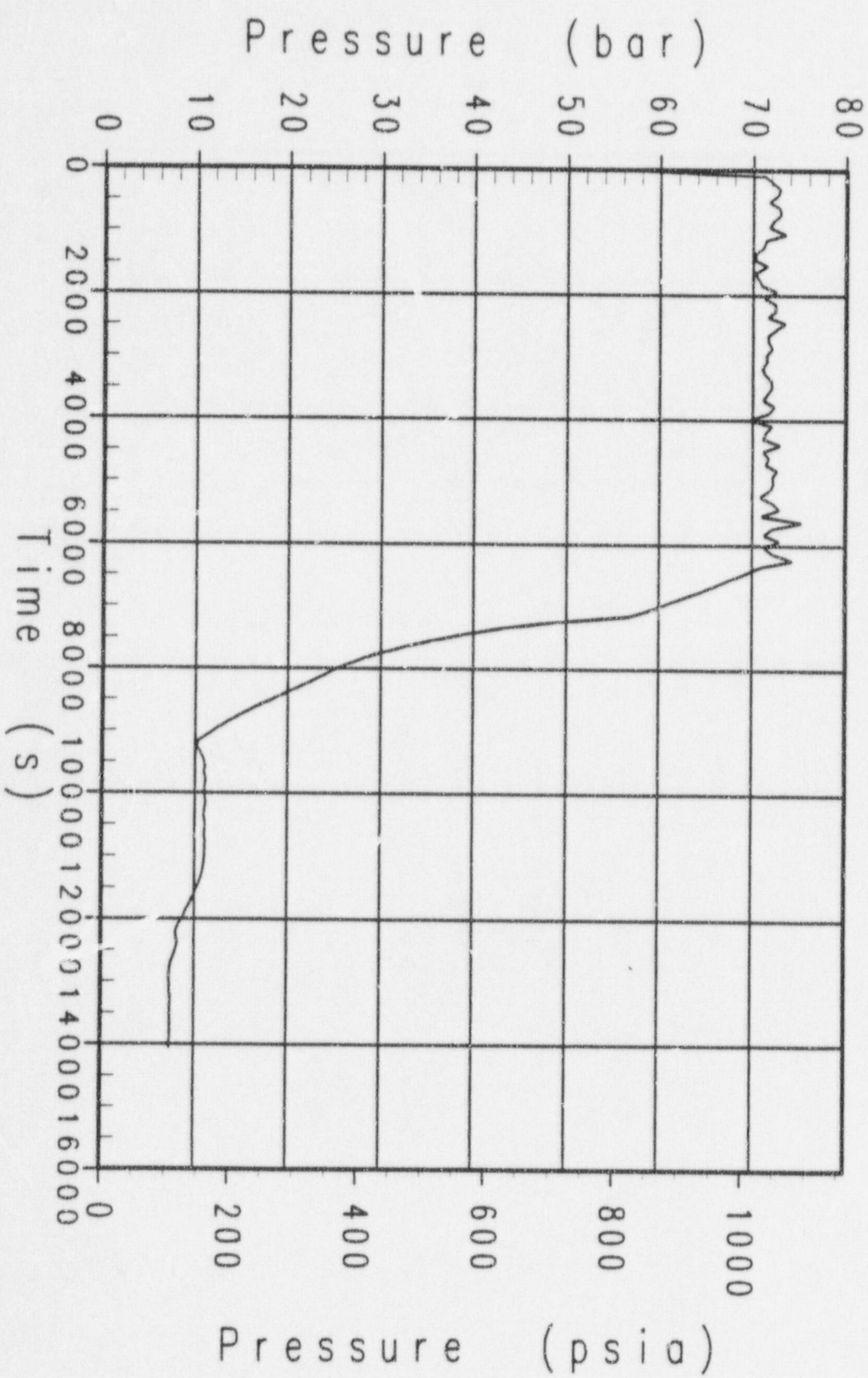

Case g1o AP600 Success Criteria MAAP4 Analysis
Primary System Pressure

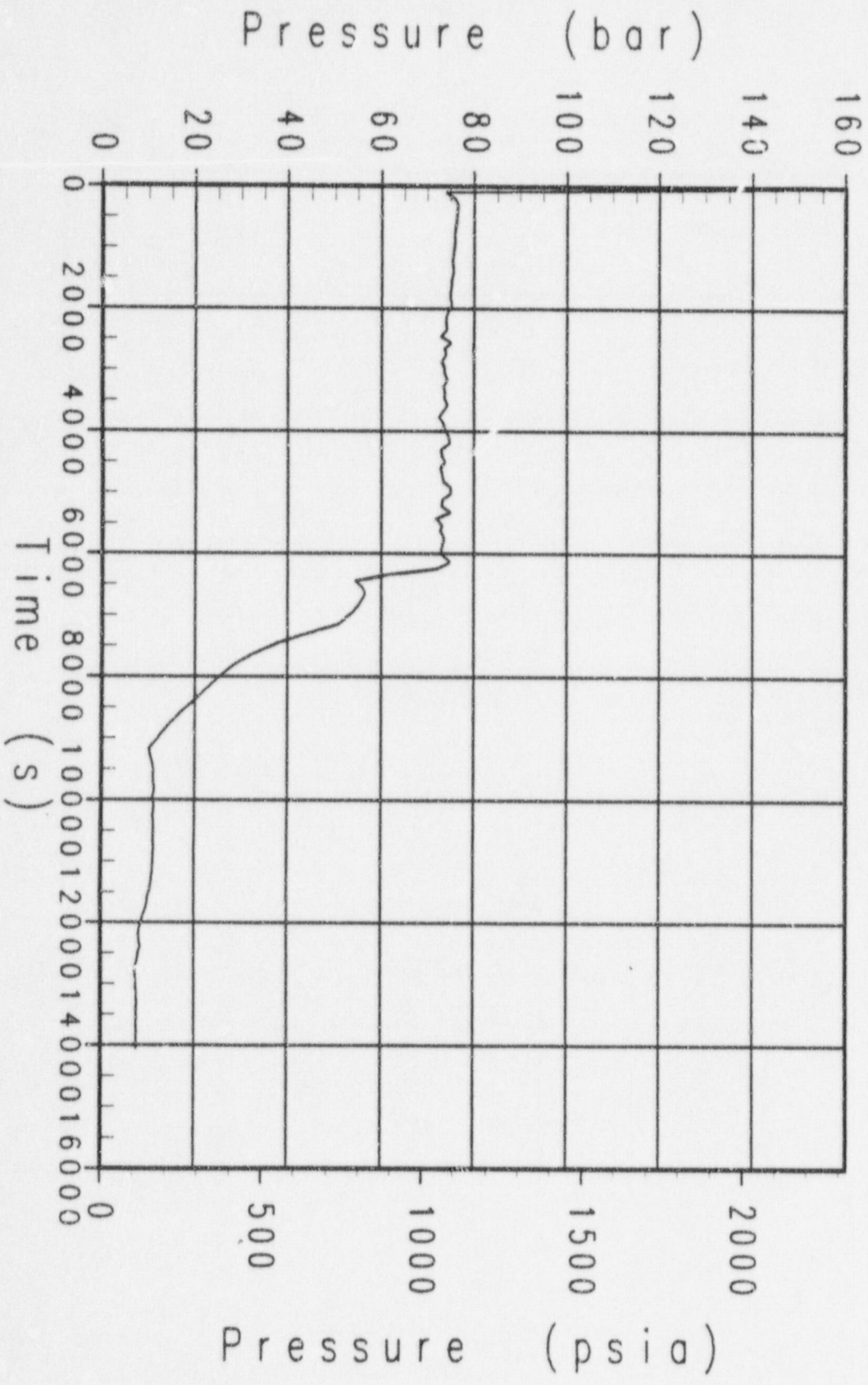

Case 910 AP600 Success Criteria MAAP4 Analysis
Containment Pressure

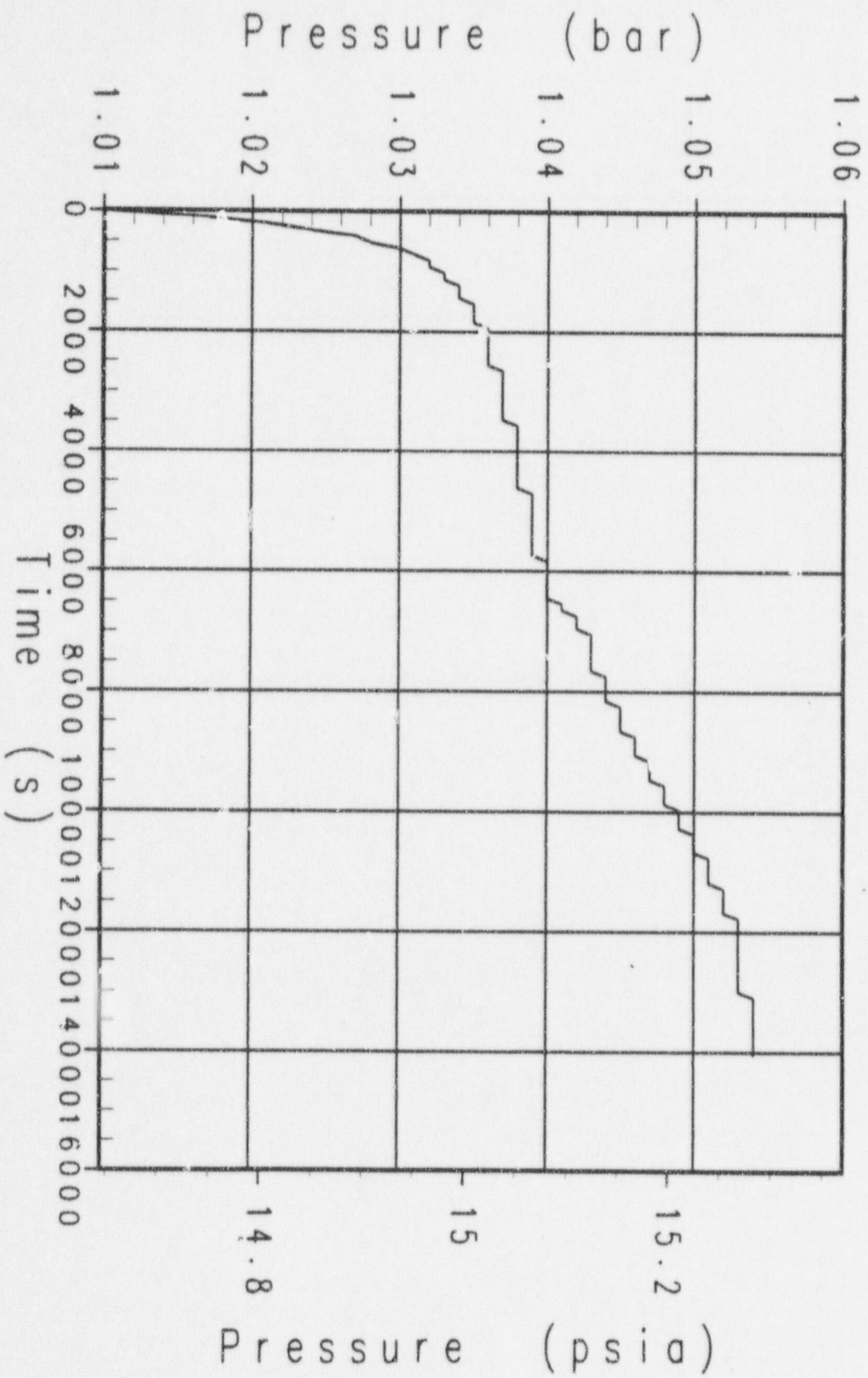

Case 91a AP600 Success Criteria MAAP4 Analysis
Unbroken Loop Steam Generator Pressure

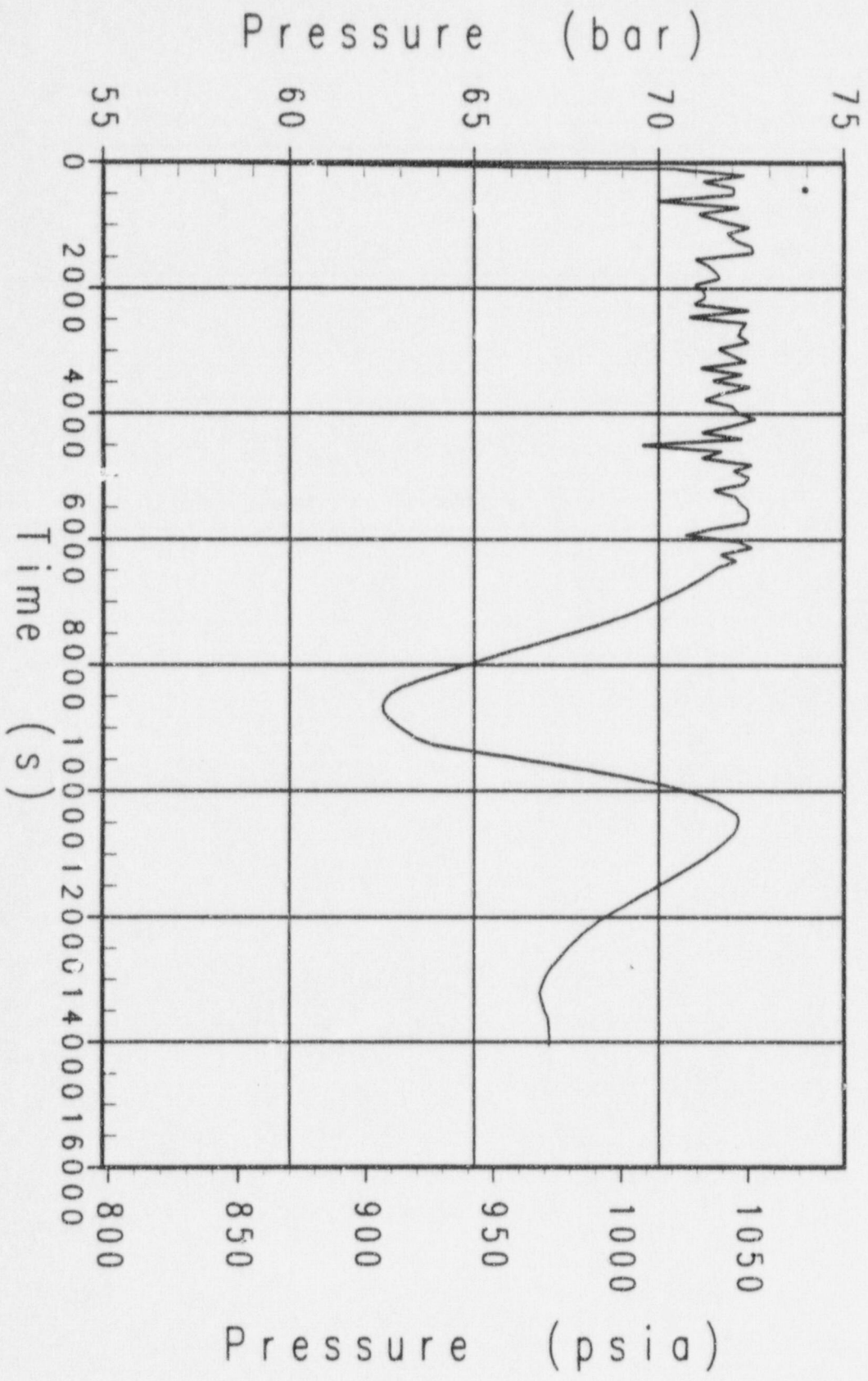

Case g1a AP600 Success Criteria MAAP4 Analysis
Decay Power

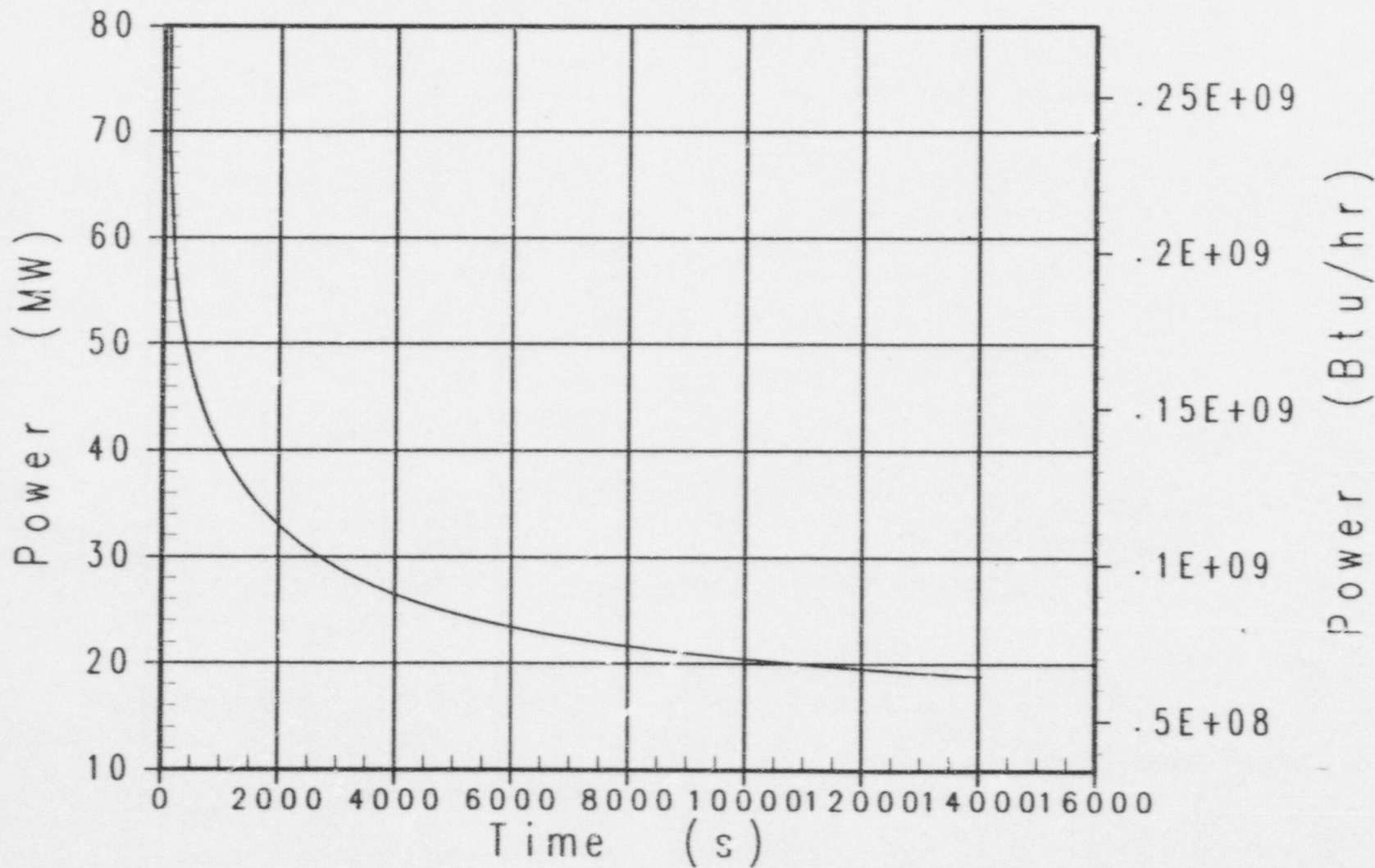

Case g1a AP600 Success Criteria MAAP4 Analysis
PRHR Heat Removal Rate

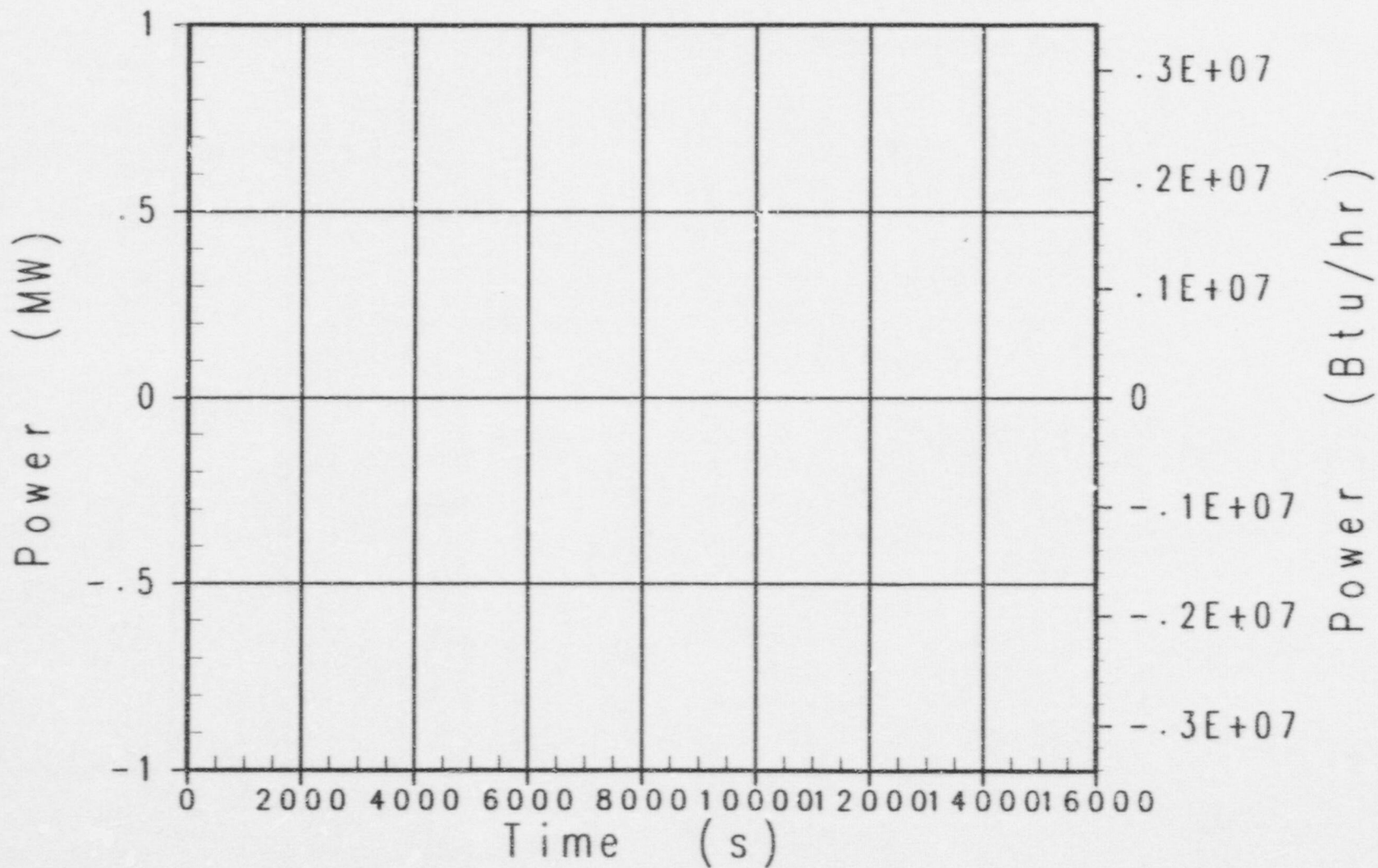

Case 91a AP600 Success Criteria MAAp4 Analysis
Peak Temperature in the Core

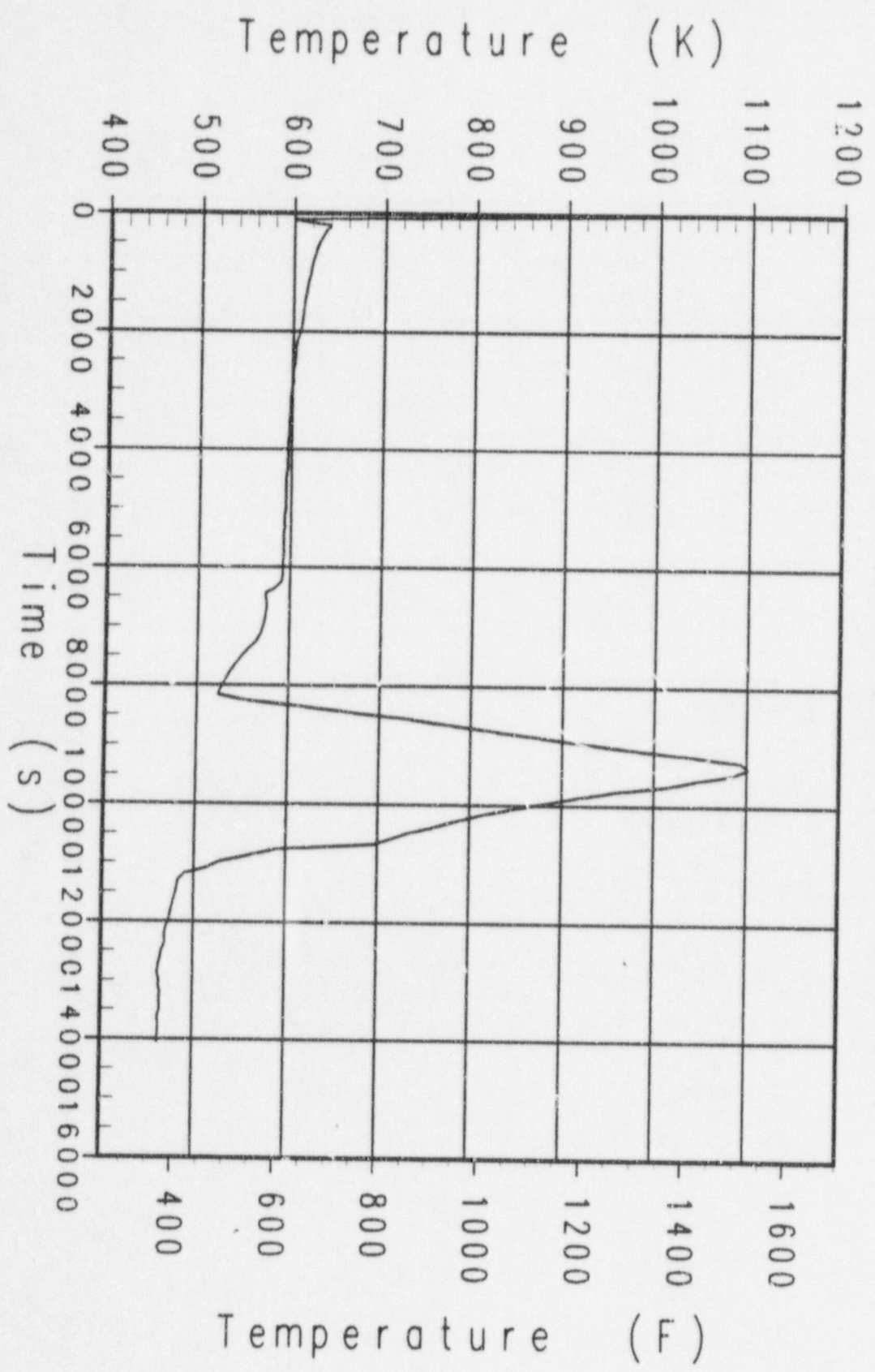

Case 910 AP600 Success Criteria MAAP4 Analysis
Cold Leg Water Temperature

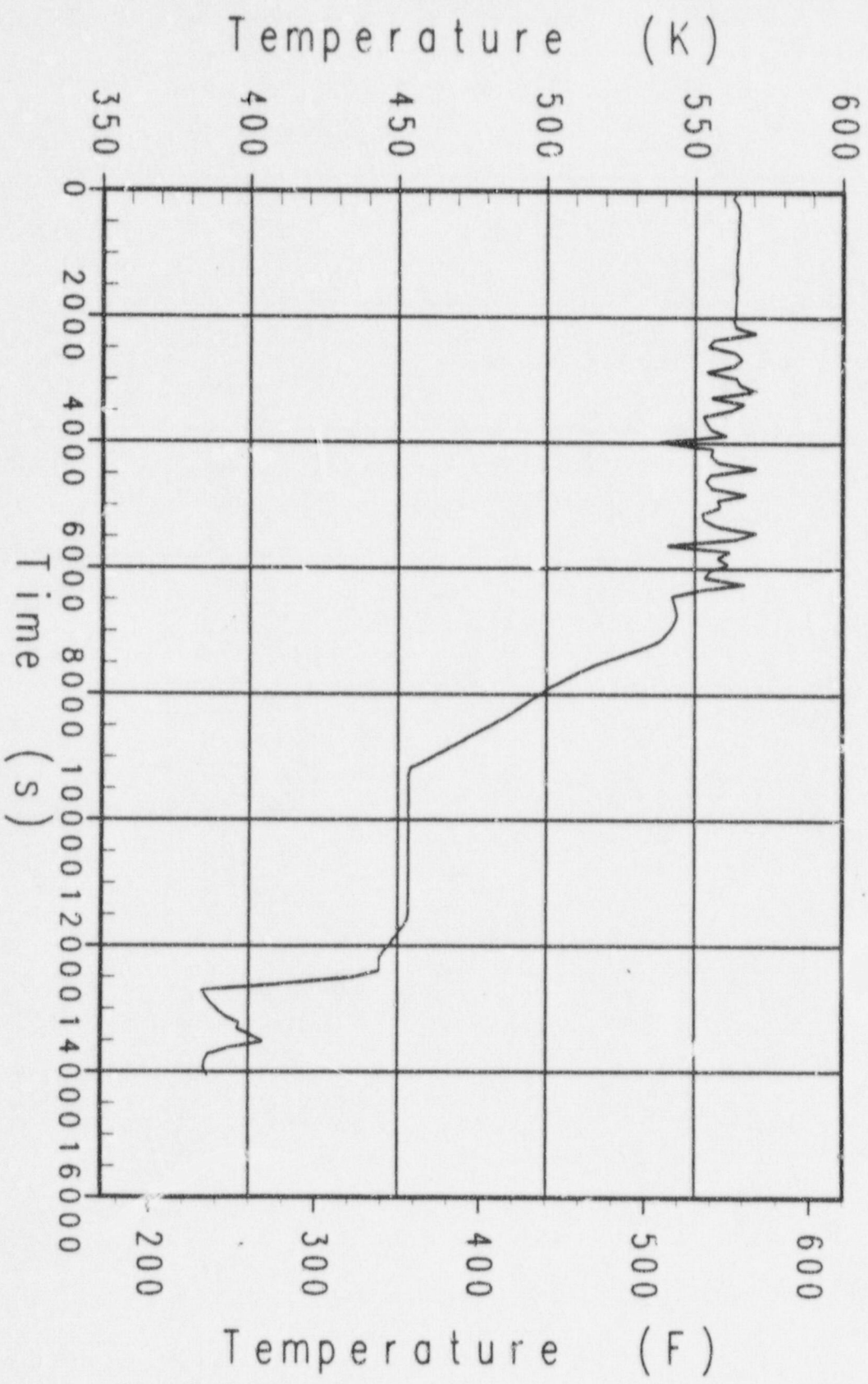

Case g1a AP600 Success Criteria MAAP4 Analysis
Core Water Temperature

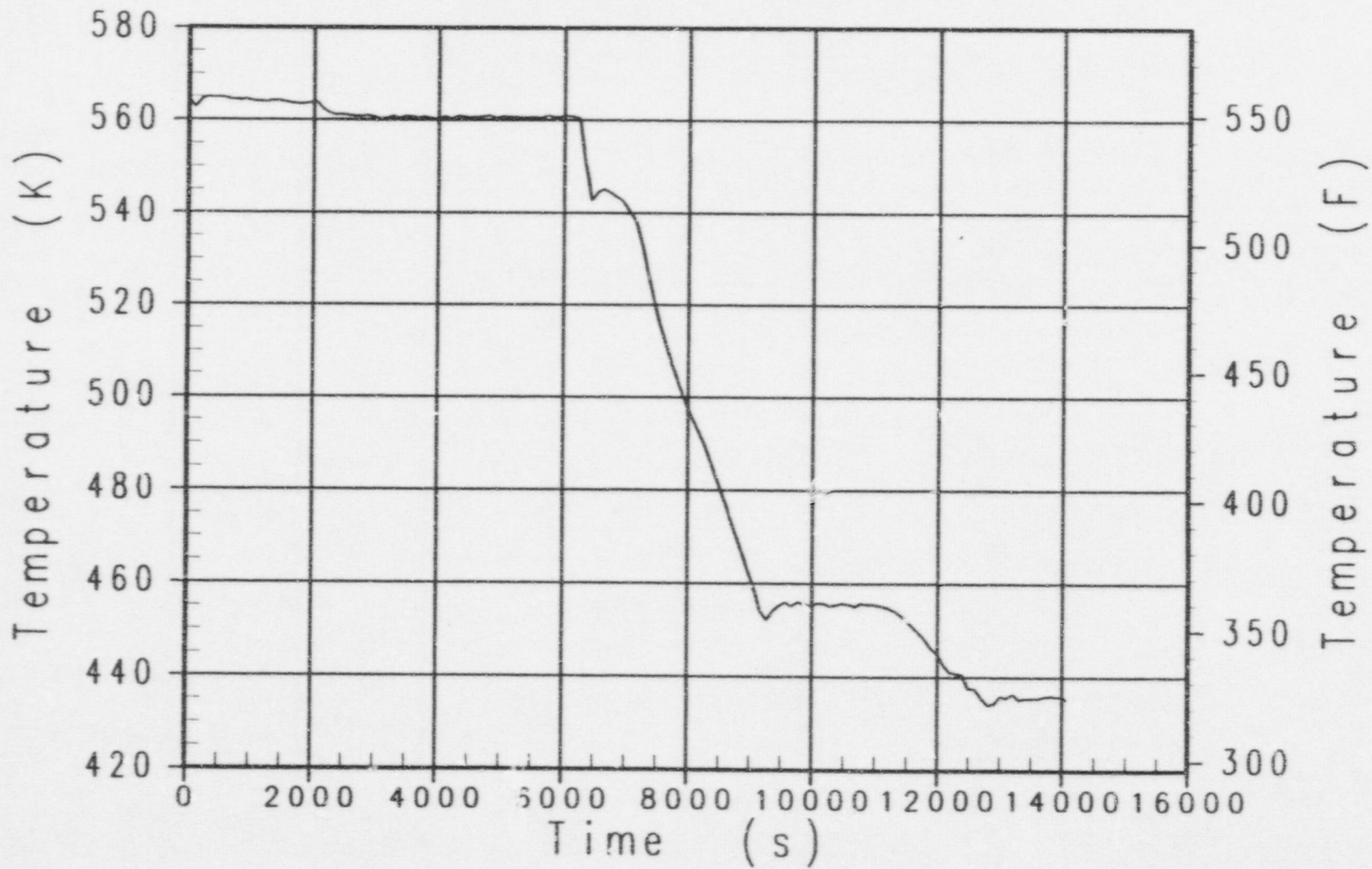

Case 91a AP600 Success Criteria MAAP4 Analysis
RPV Downcomer Water Temperature

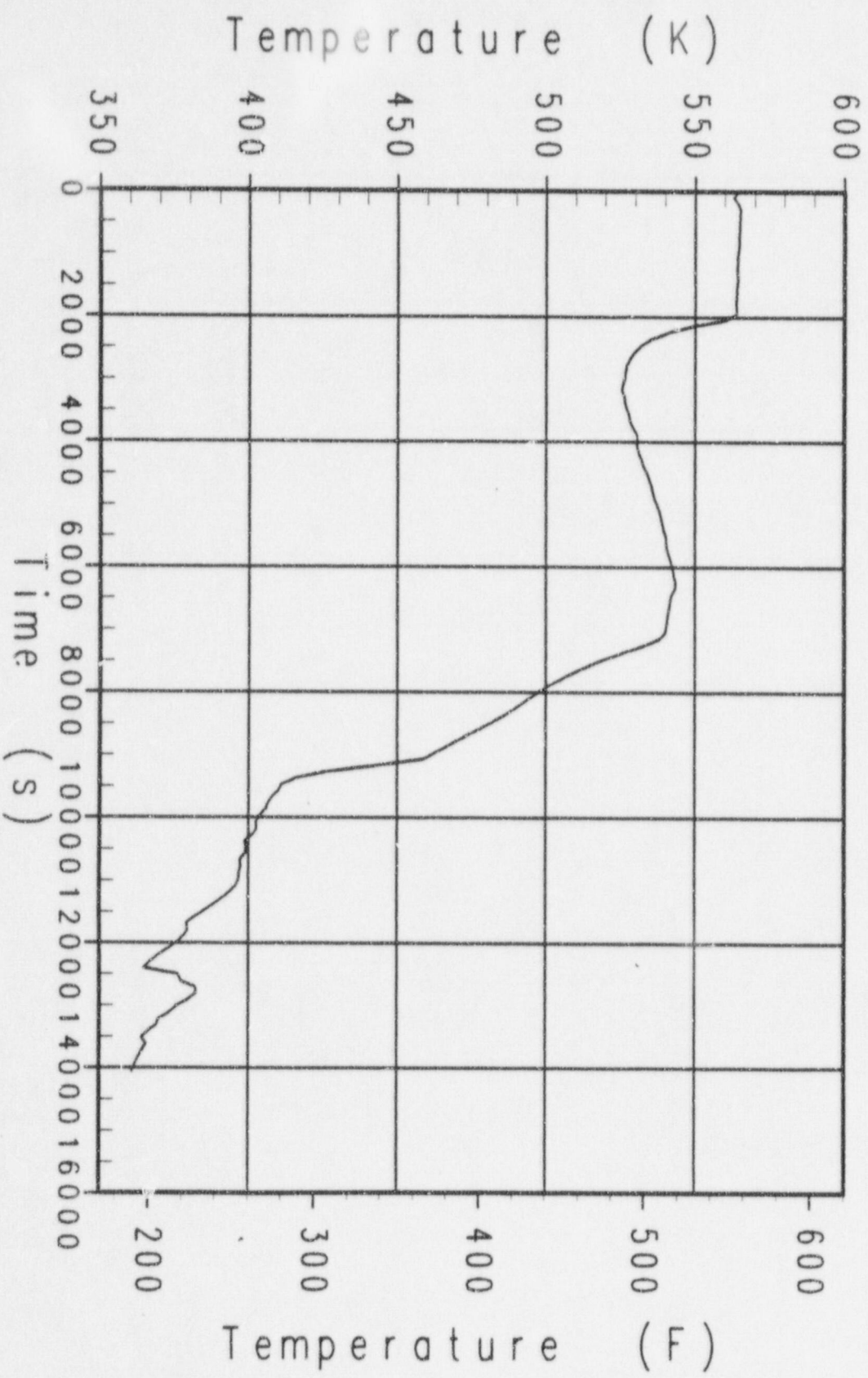

Case 910 AP600 Success Criteria MAAP4 Analysis
IRWST Water Temperature

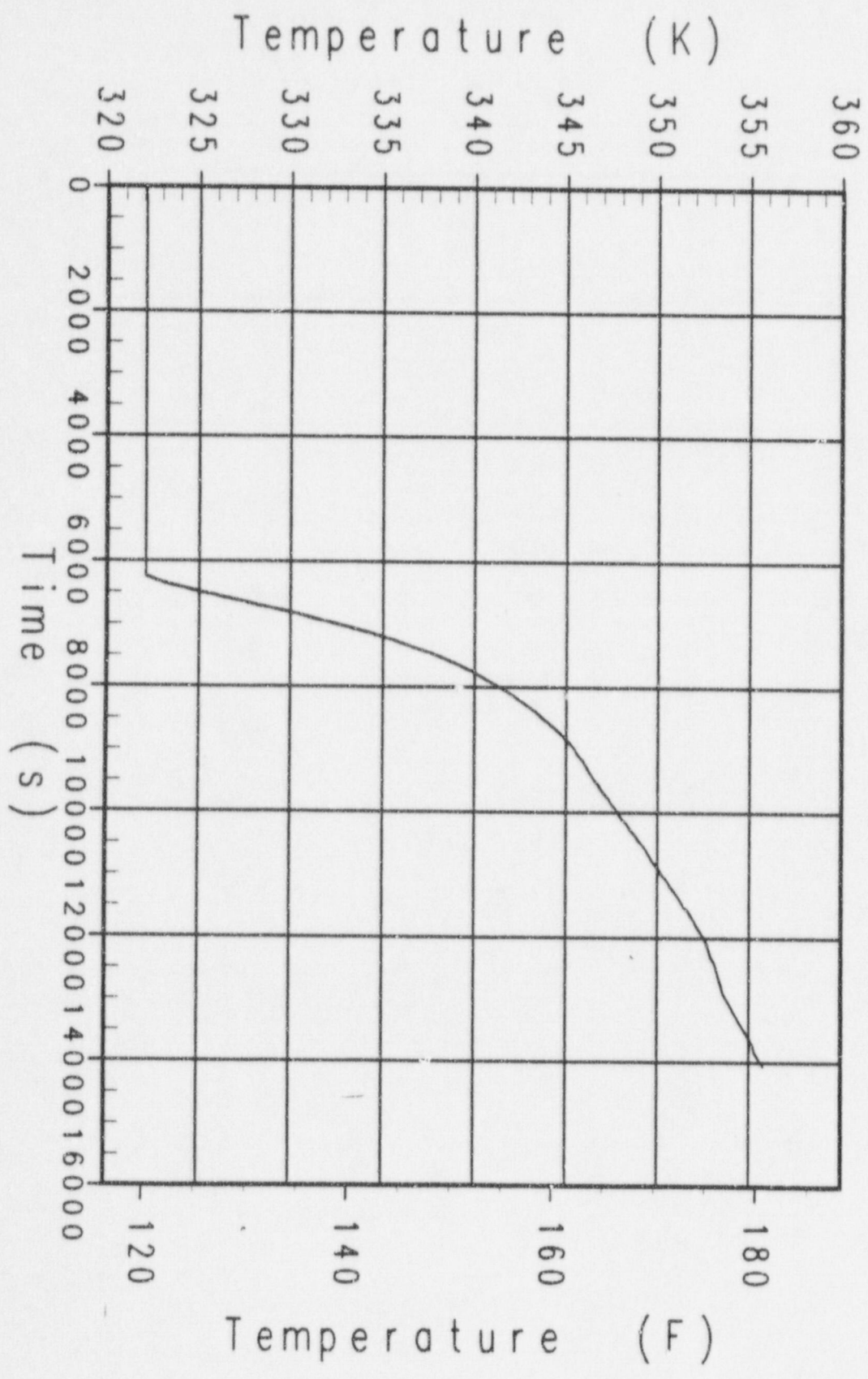

Case 91a AP600 Success Criteria MAPP4 Analysis
Accumulator and NRHR Injection Flowrate

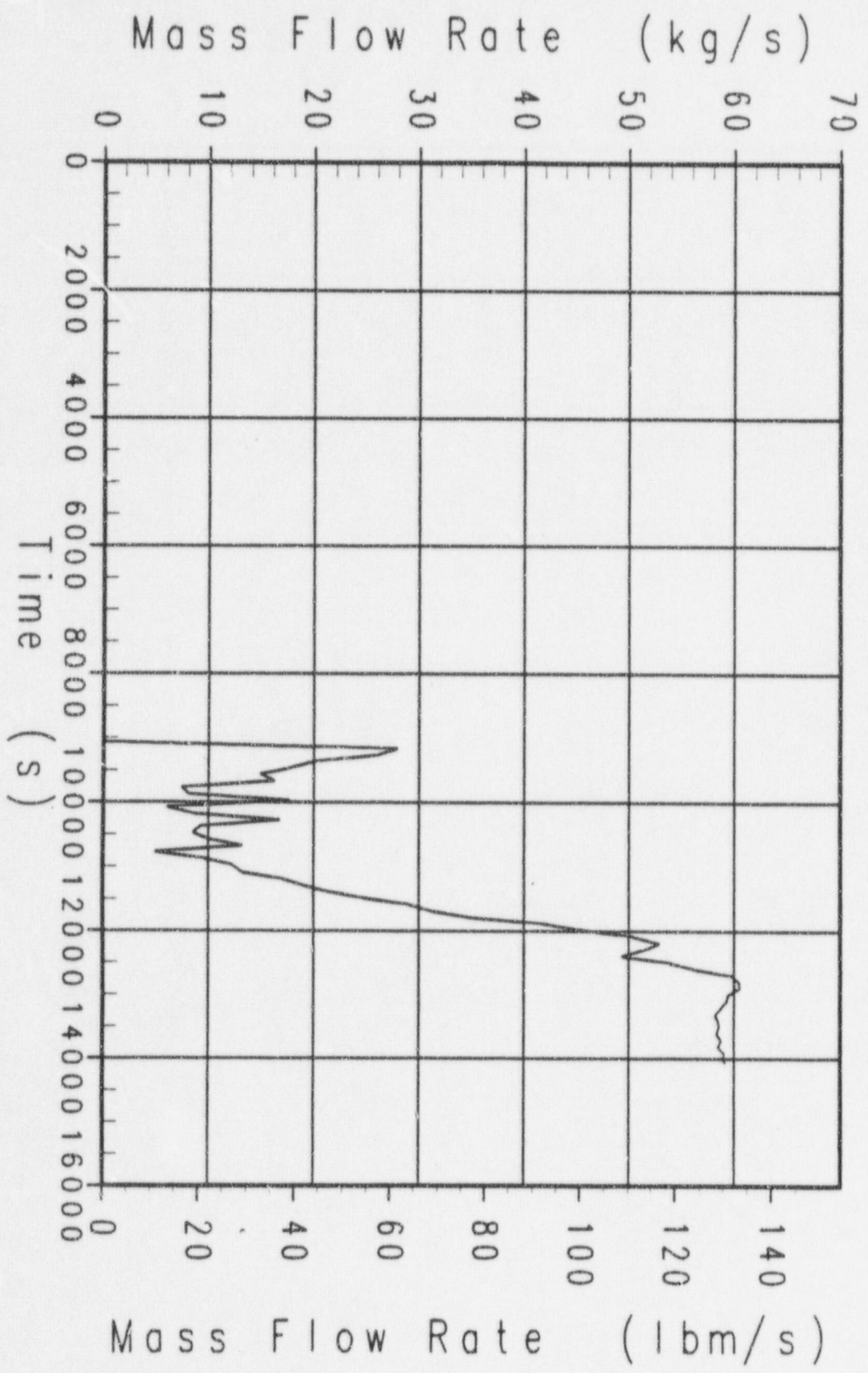

Case g1a AP600 Success Criteria MAAP4 Analysis
RCS Break Gas Flowrate

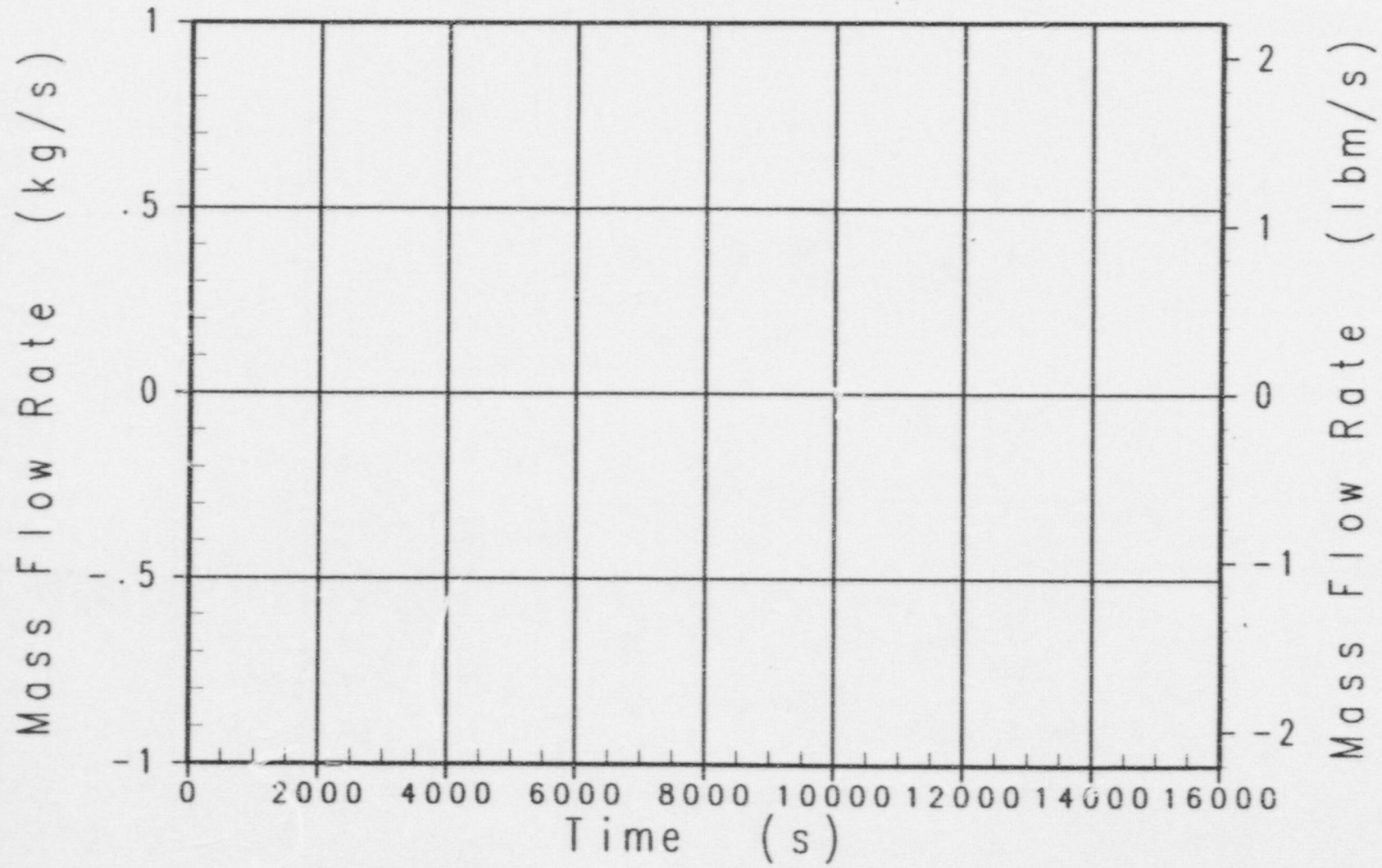

Case g1a AP600 Success Criteria MAAp4 Analysis
ADS Stage 4 Gas Flowrate

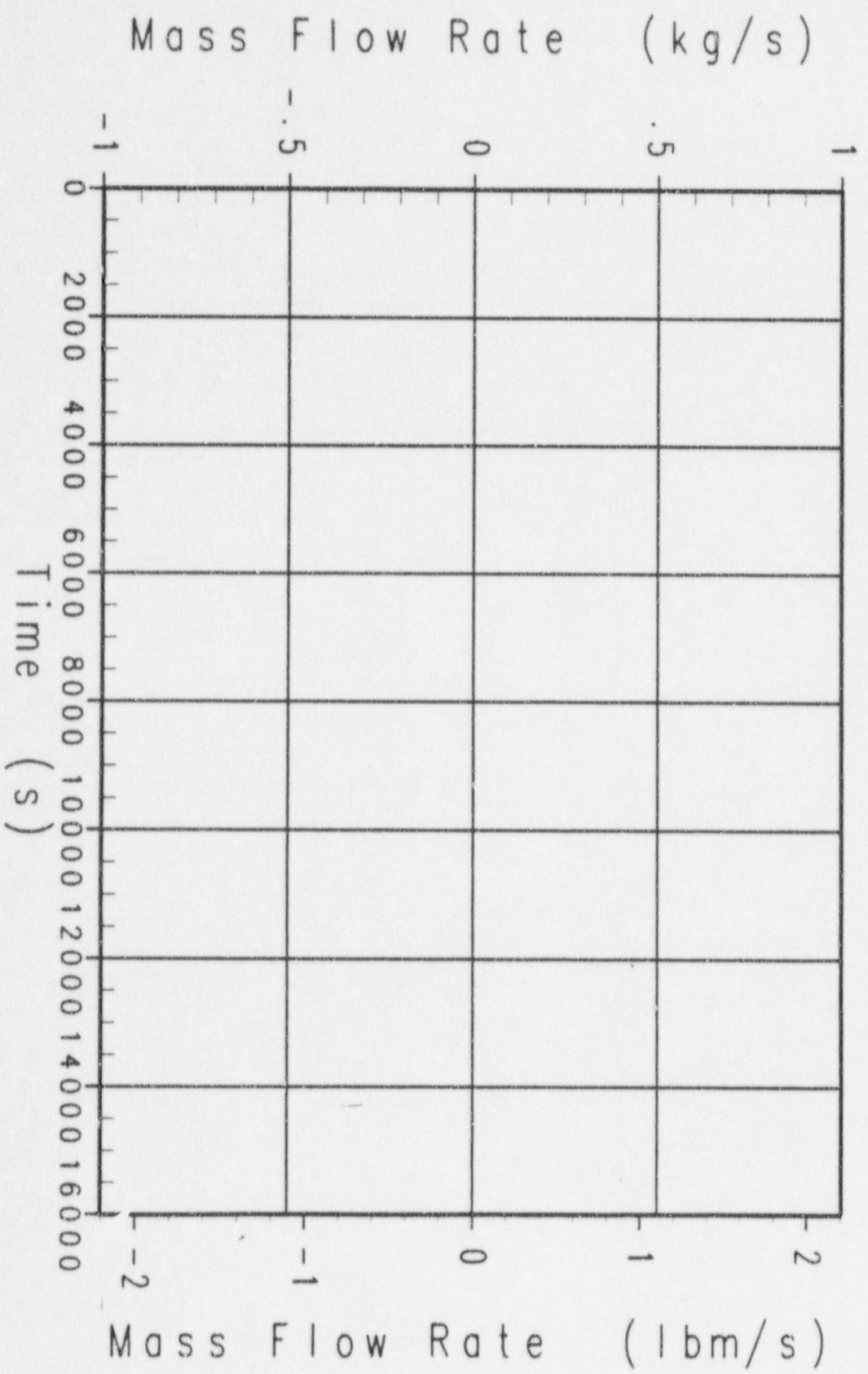

Case 91a AP600 Success Criteria MAAP4 Analysis
Safety Valve and ADS Stages 1-3 Gas Flowrate

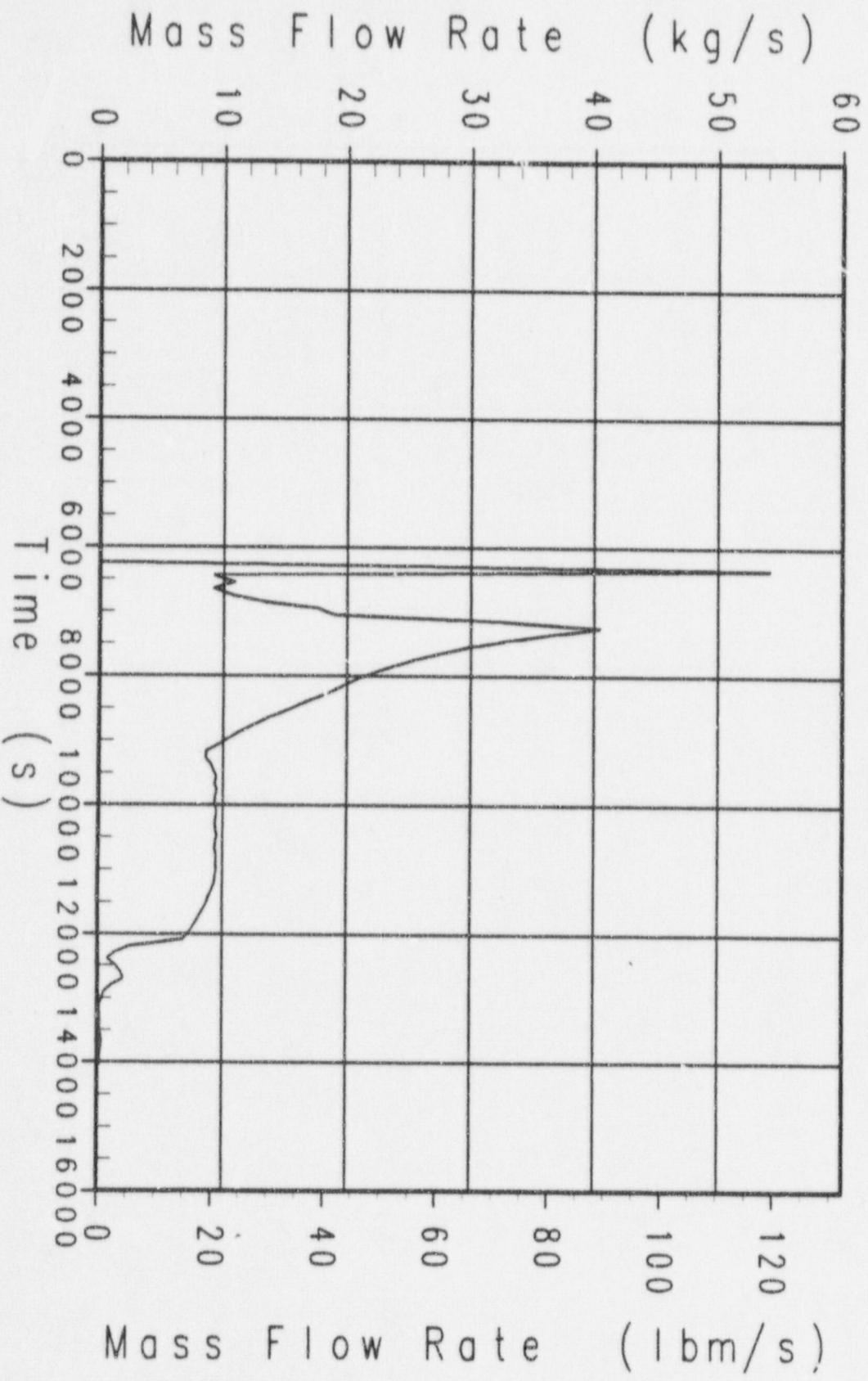

Case g1a AP600 Success Criteria MAAP4 Analysis
RCS Break Liquid Flowrate

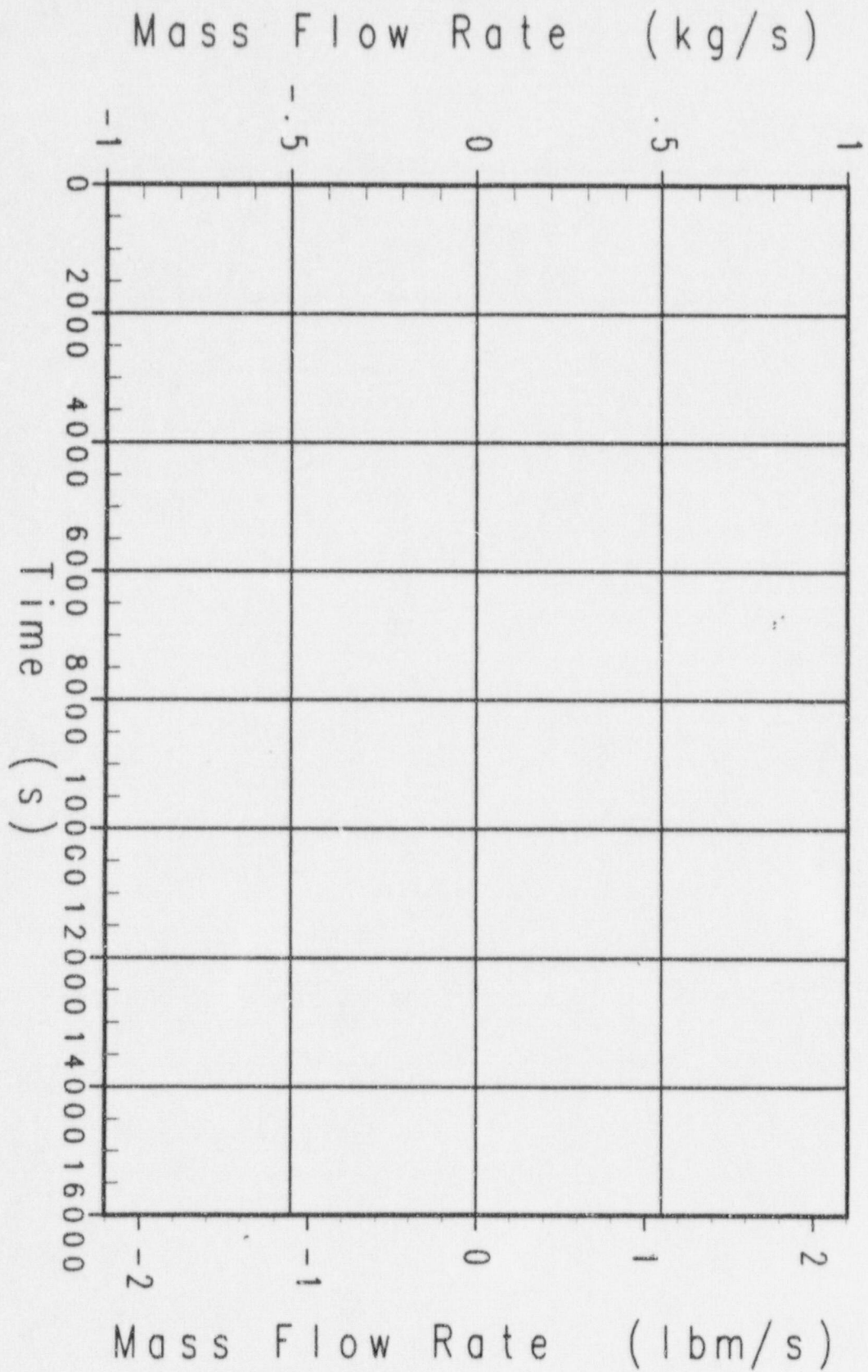

Case 910 AP600 Success Criteria MAAP4 Analysis
ADS Stage 4 Liquid Flowrate

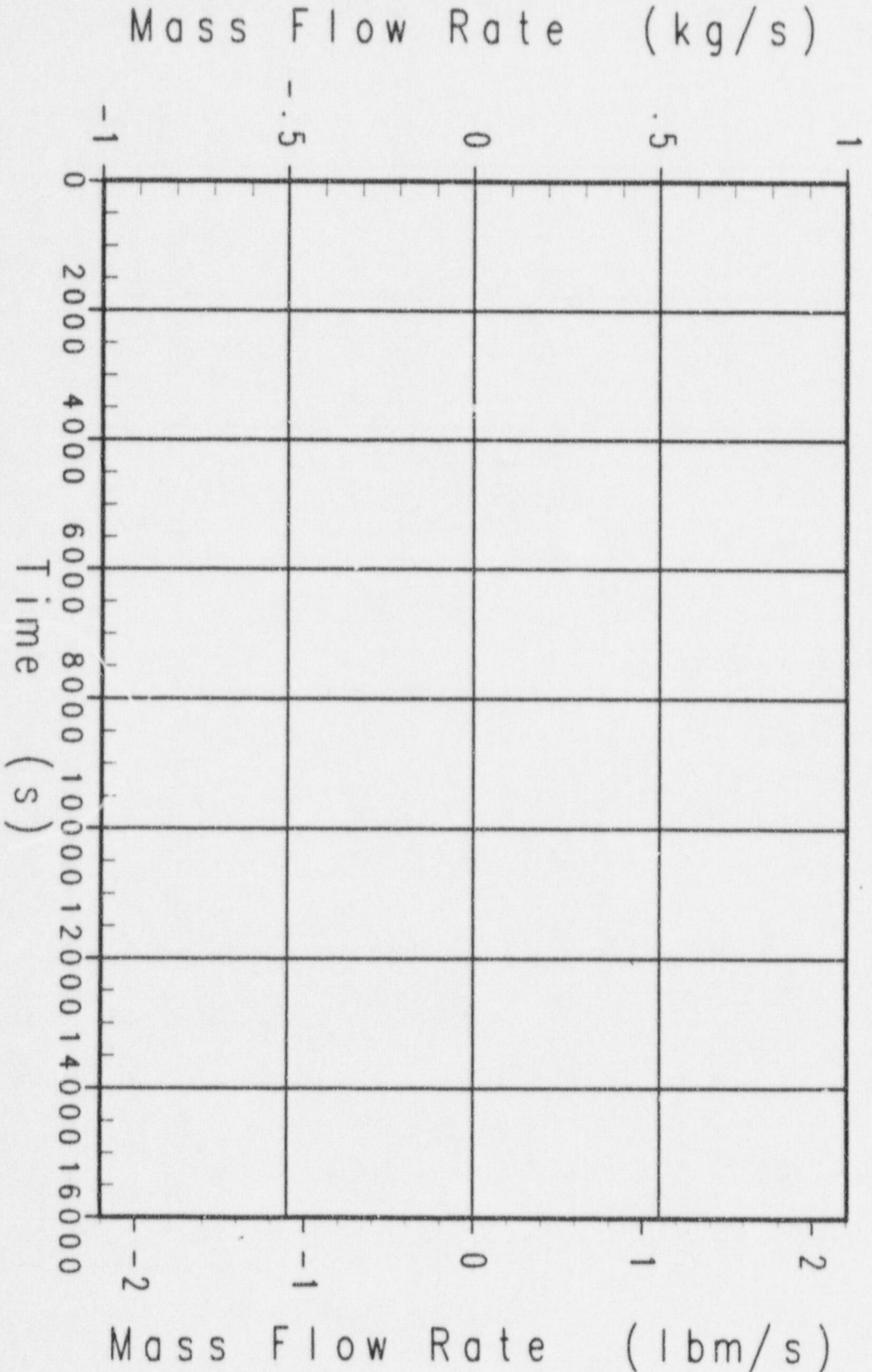

Case 91a AP600 Success Criteria MAAP4 Analysis
IRWST Injection Flowrate (neg. means into RCS)

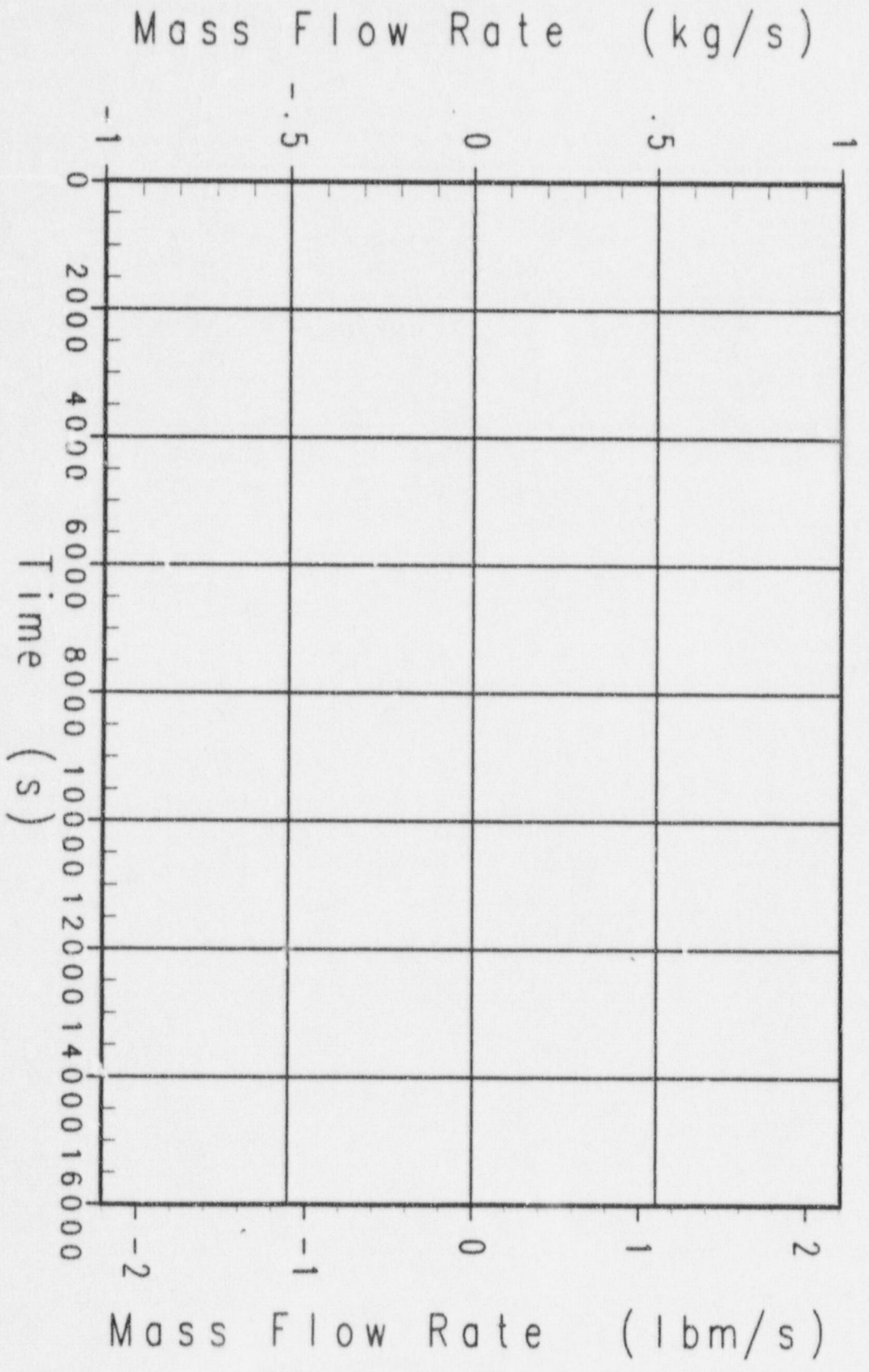

Case g1a AP600 Success Criteria MAAp4 Analysis
CMT-1 Injection Flowrate

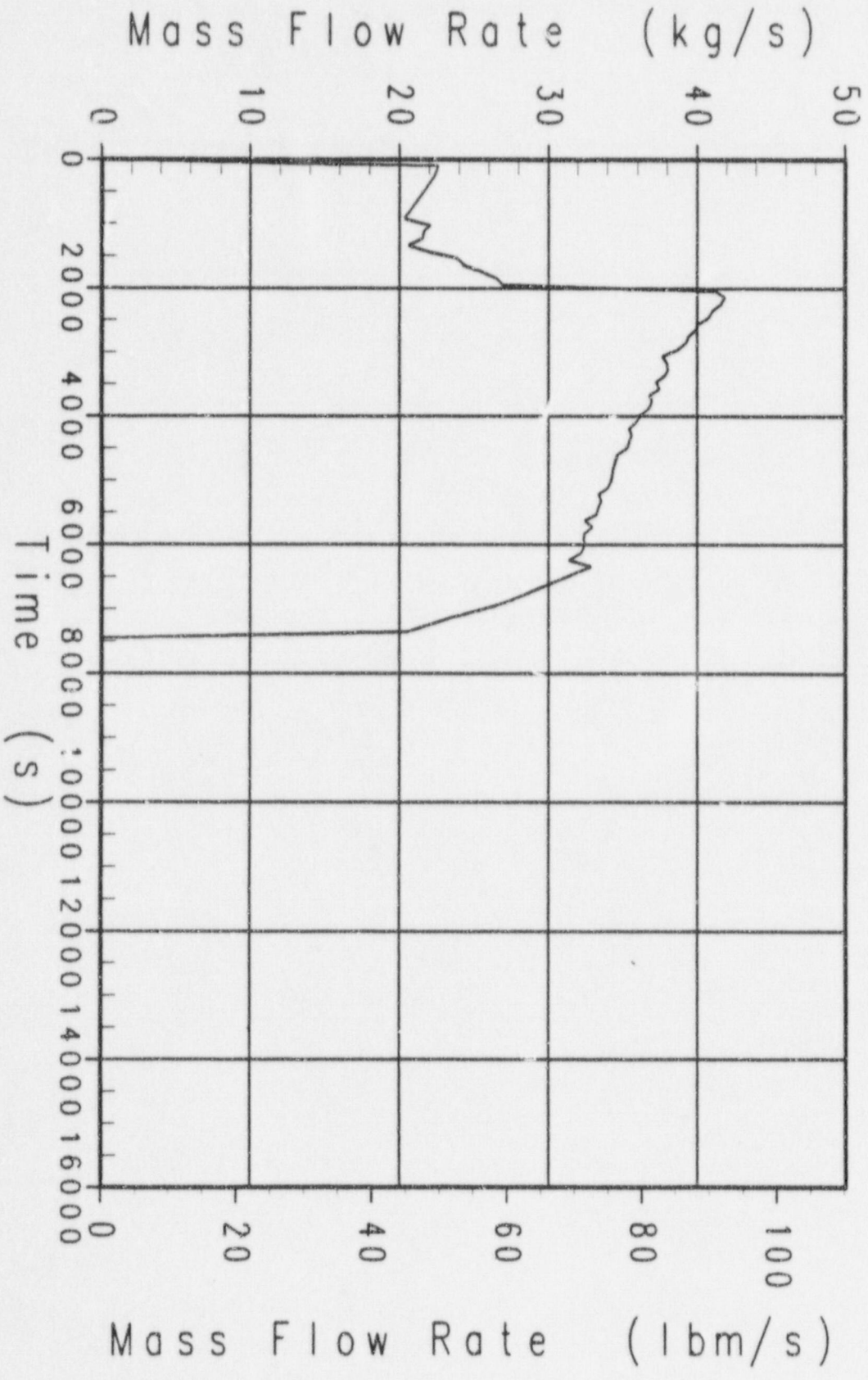

Case g1a AP600 Success Criteria MAAp4 Analysis
Safety Valve and ADS Stages 1-3 Liquid Flowrate

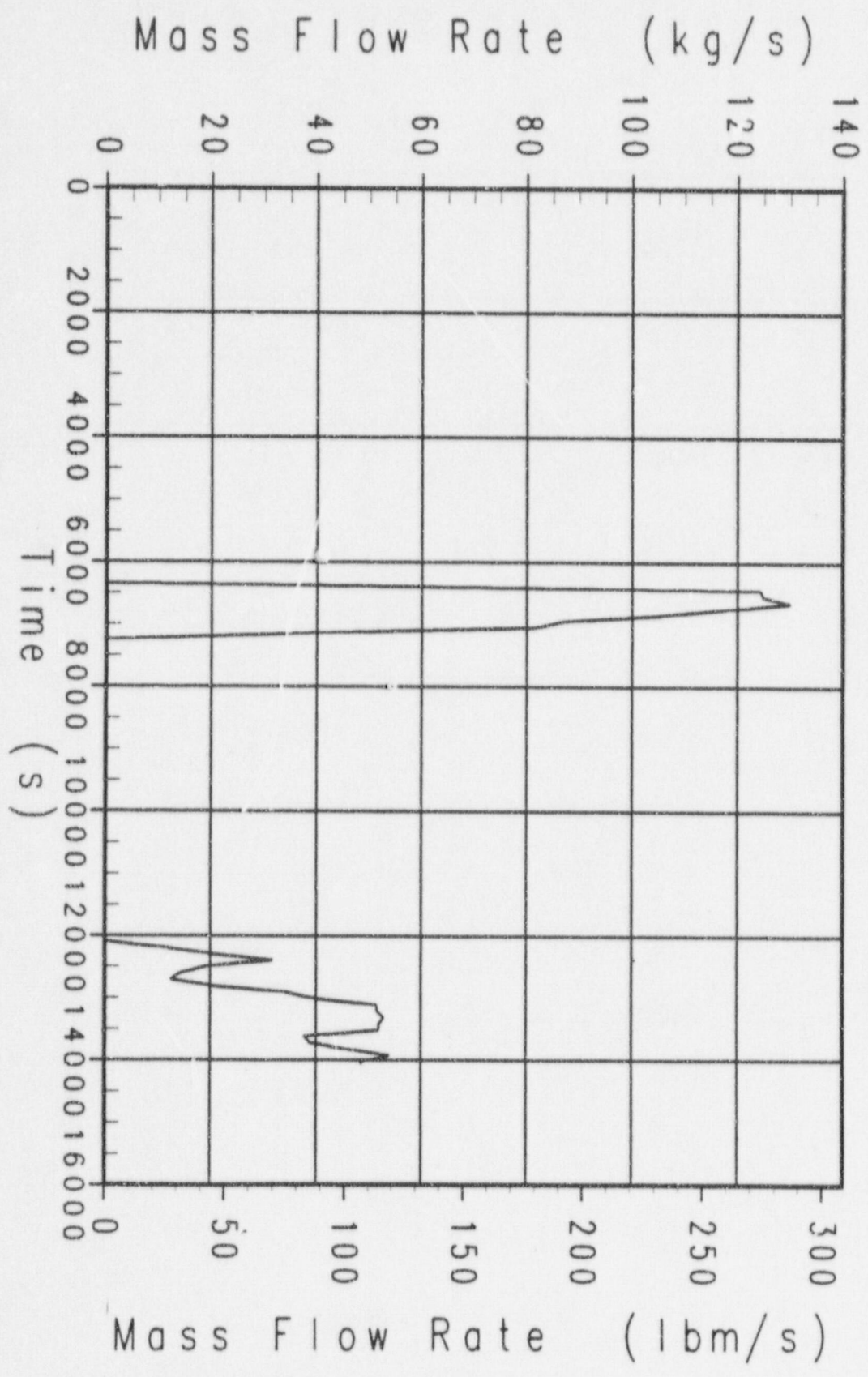

Case g1a AP600 Success Criteria MAAP4 Analysis
CMT-1 Water Level

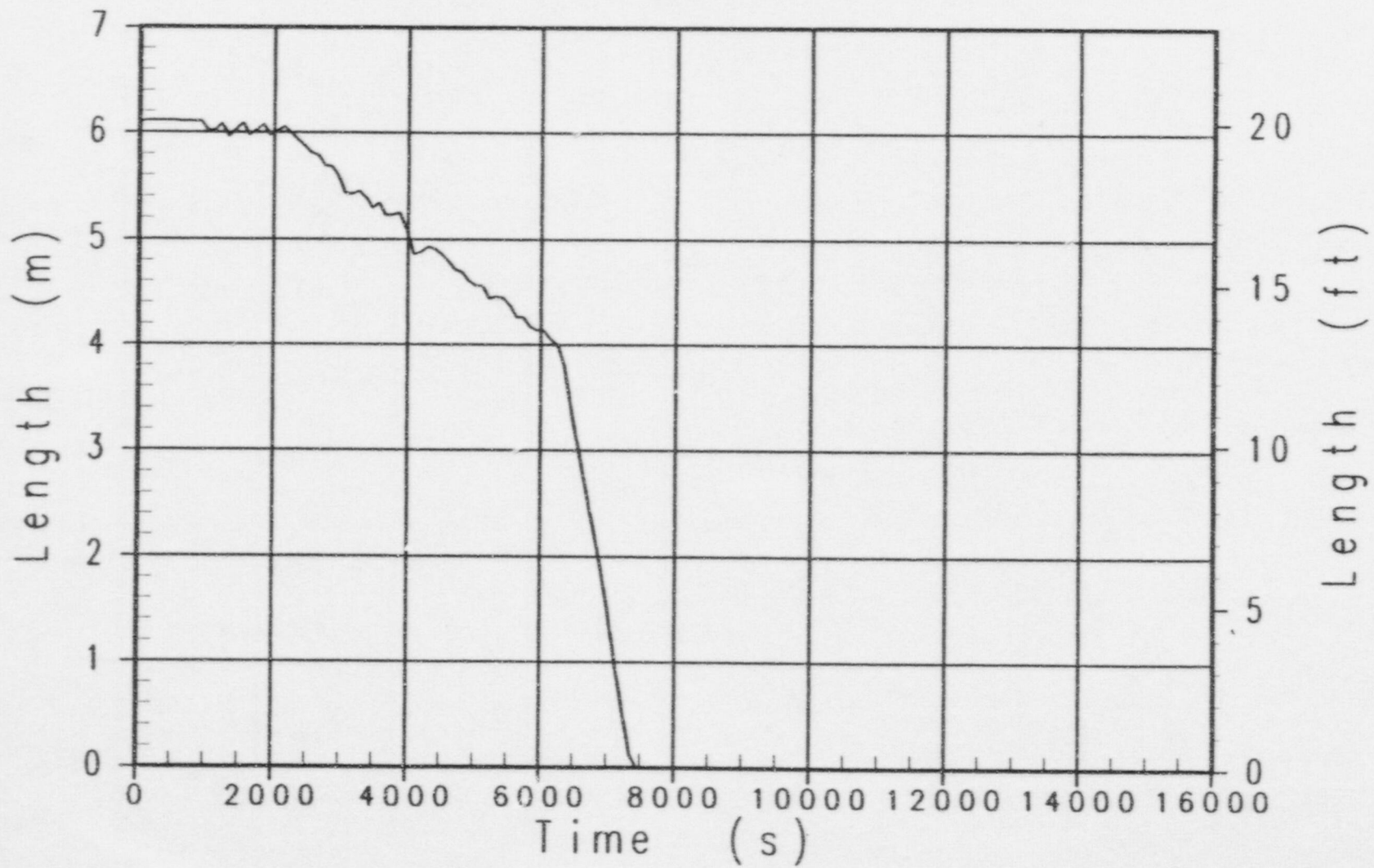

Case g1a AP600 Success Criteria MAAP4 Analysis
Pressurizer Water Level (From Pzr Bottom)

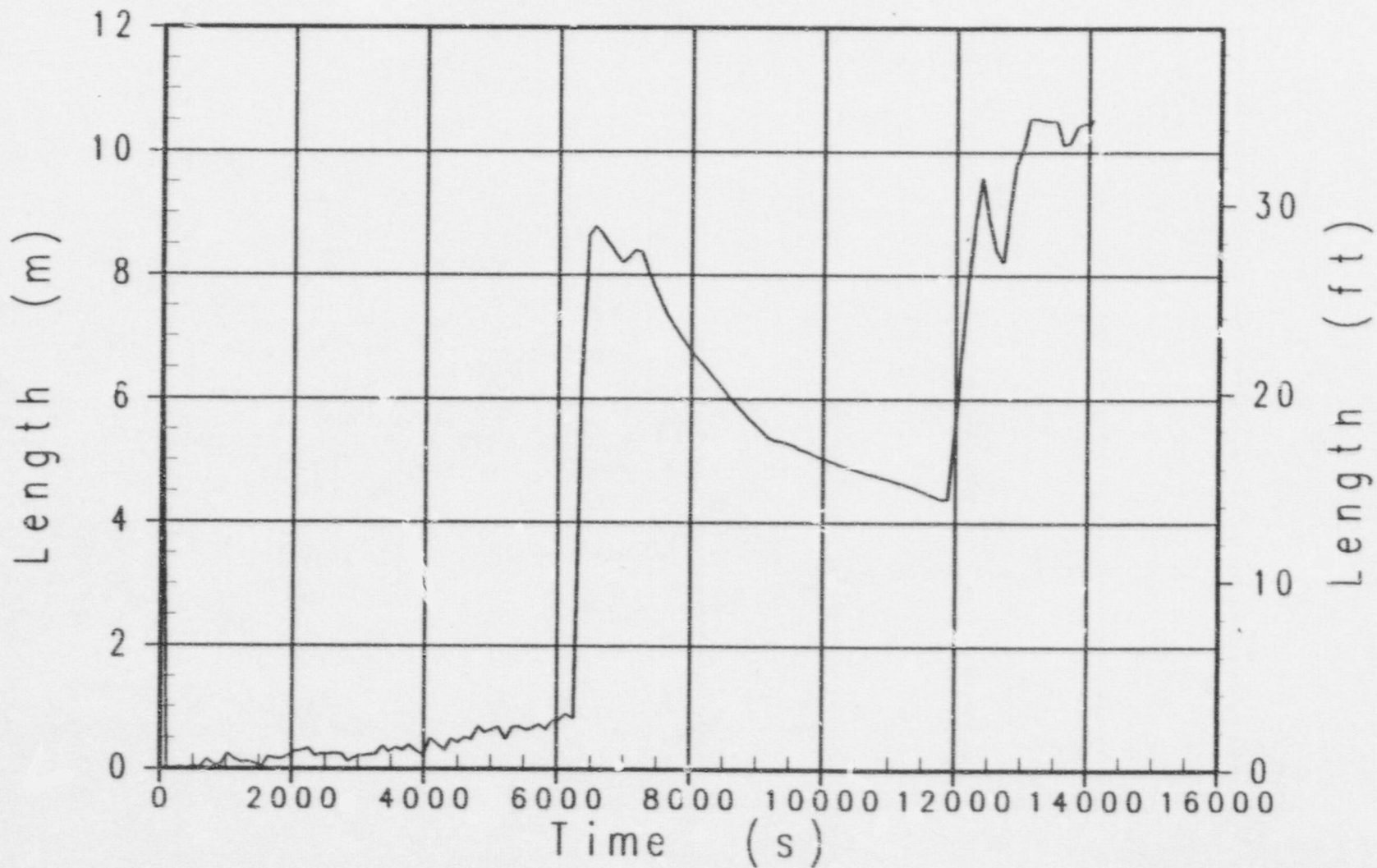

Case 94d AP600 Success Criteria MAPP4 Analysis
Broken Loop Steam Generator Pressure

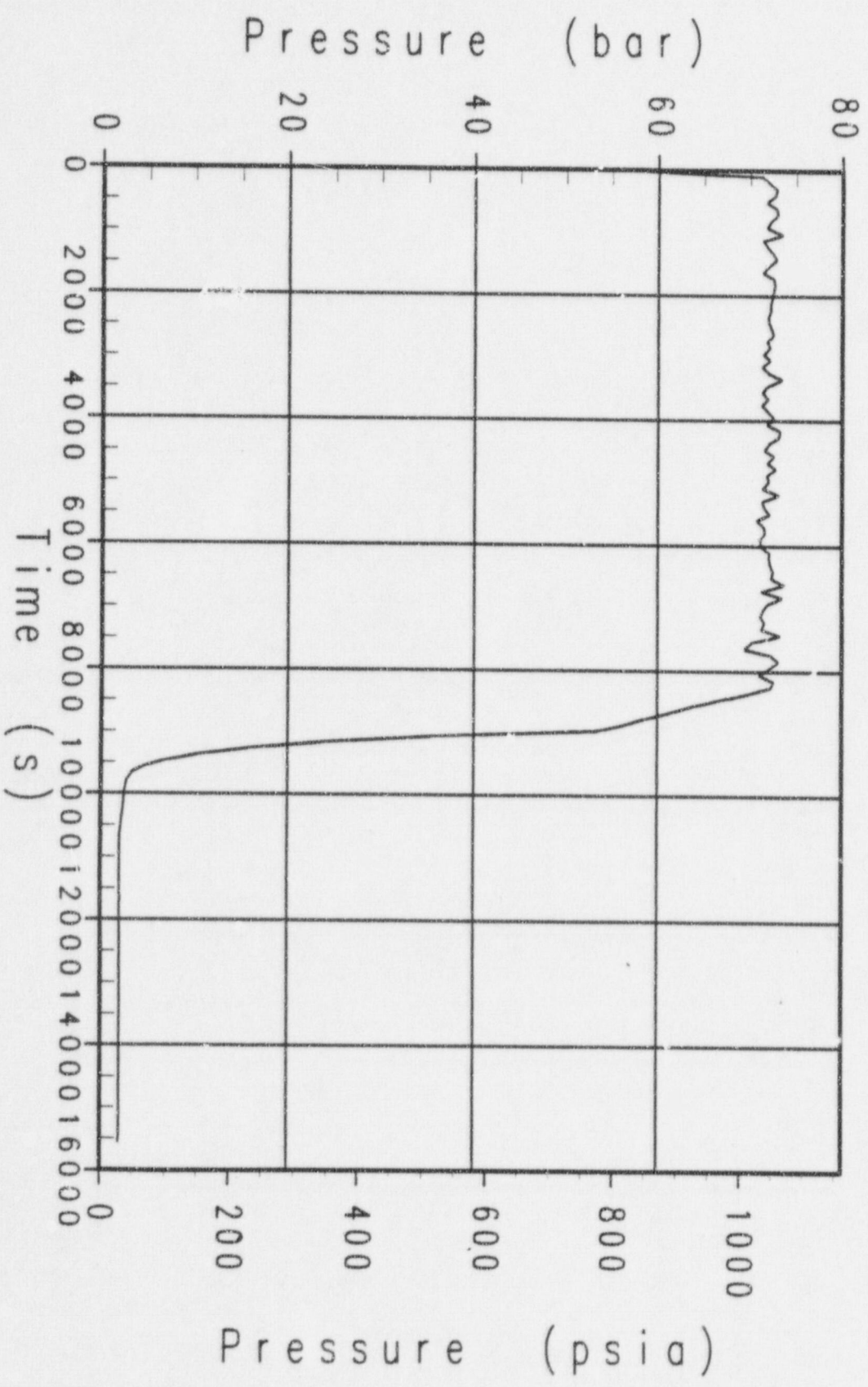

Case 94d AP600 Success Criteria MAAP4 Analysis
Primary System Pressure

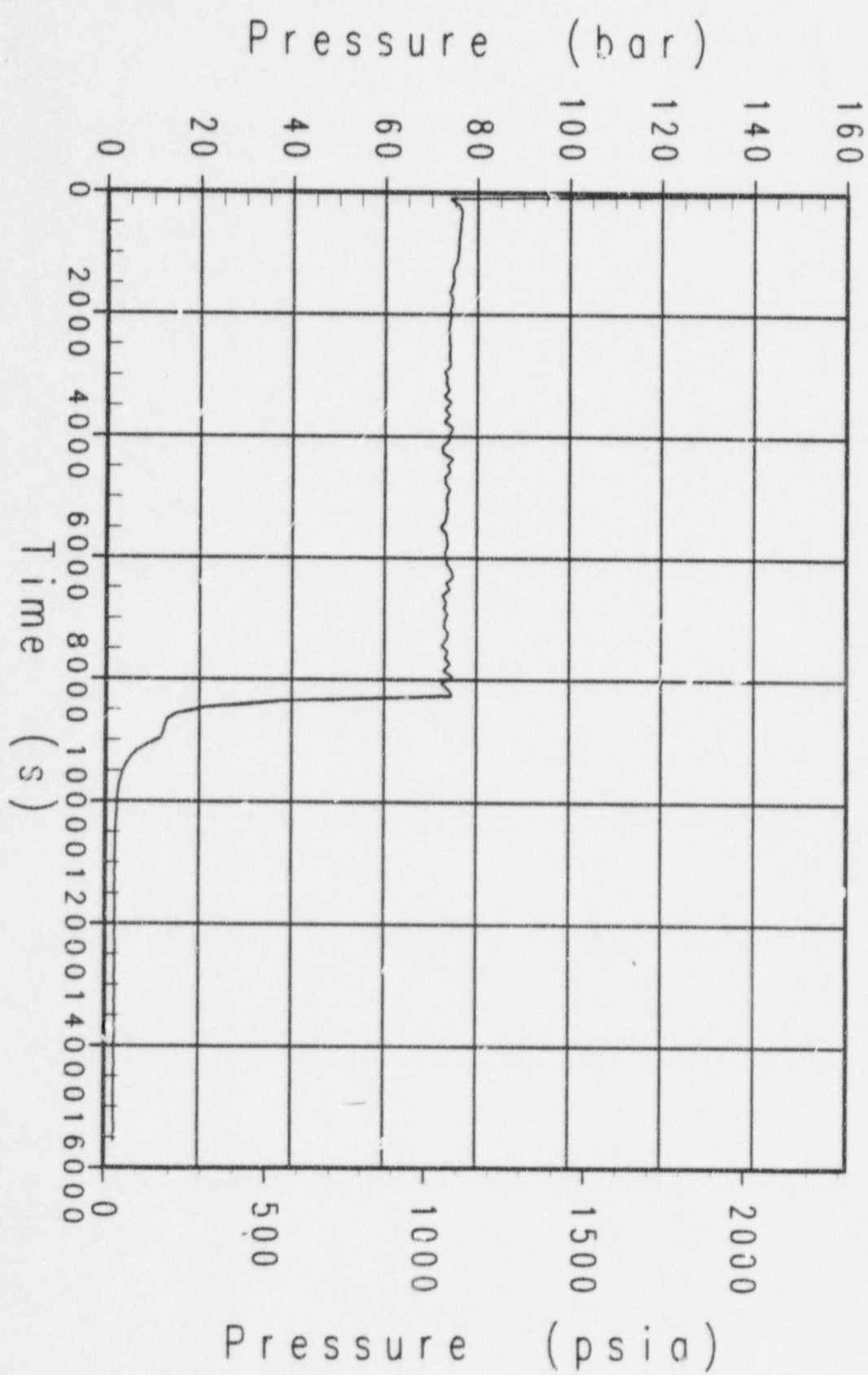

Case g4d AP600 Success Criteria MAAP4 Analysis
Containment Pressure

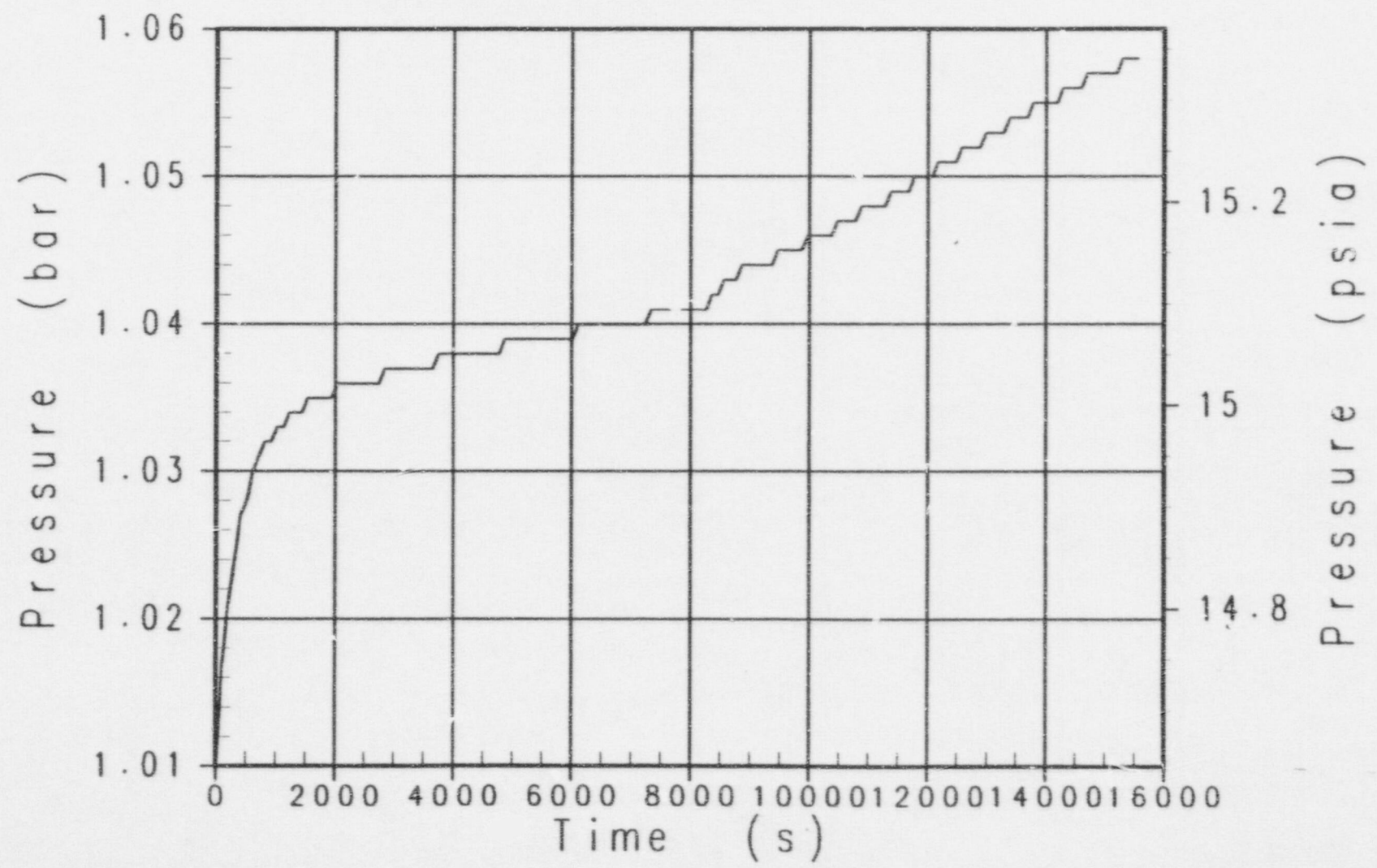

Case g4d AP600 Success Criteria MAAP4 Analysis
Unbroken Loop Steam Generator Pressure

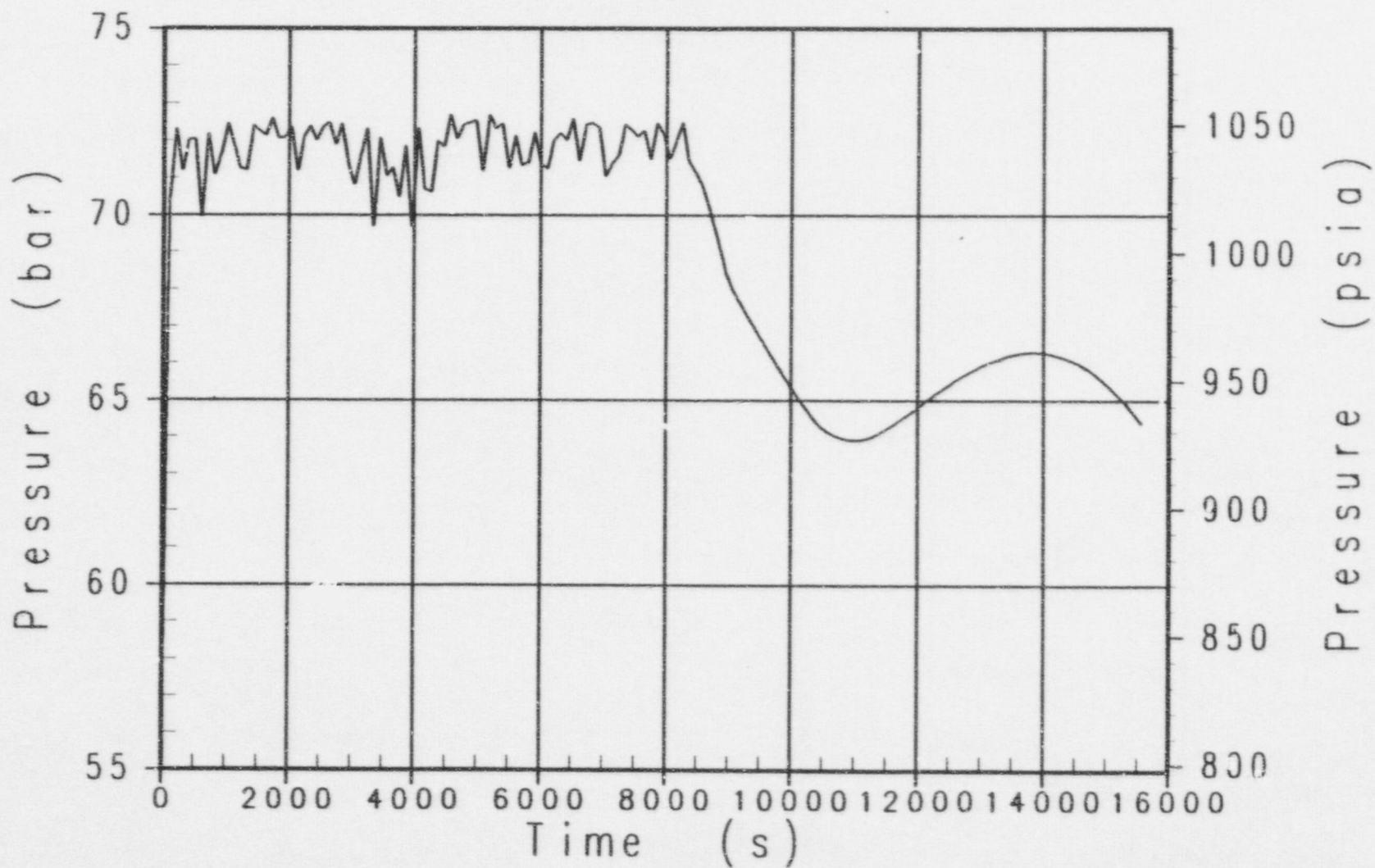

Case 94d AP600 Success Criteria MAAP4 Analysis
Decay Power

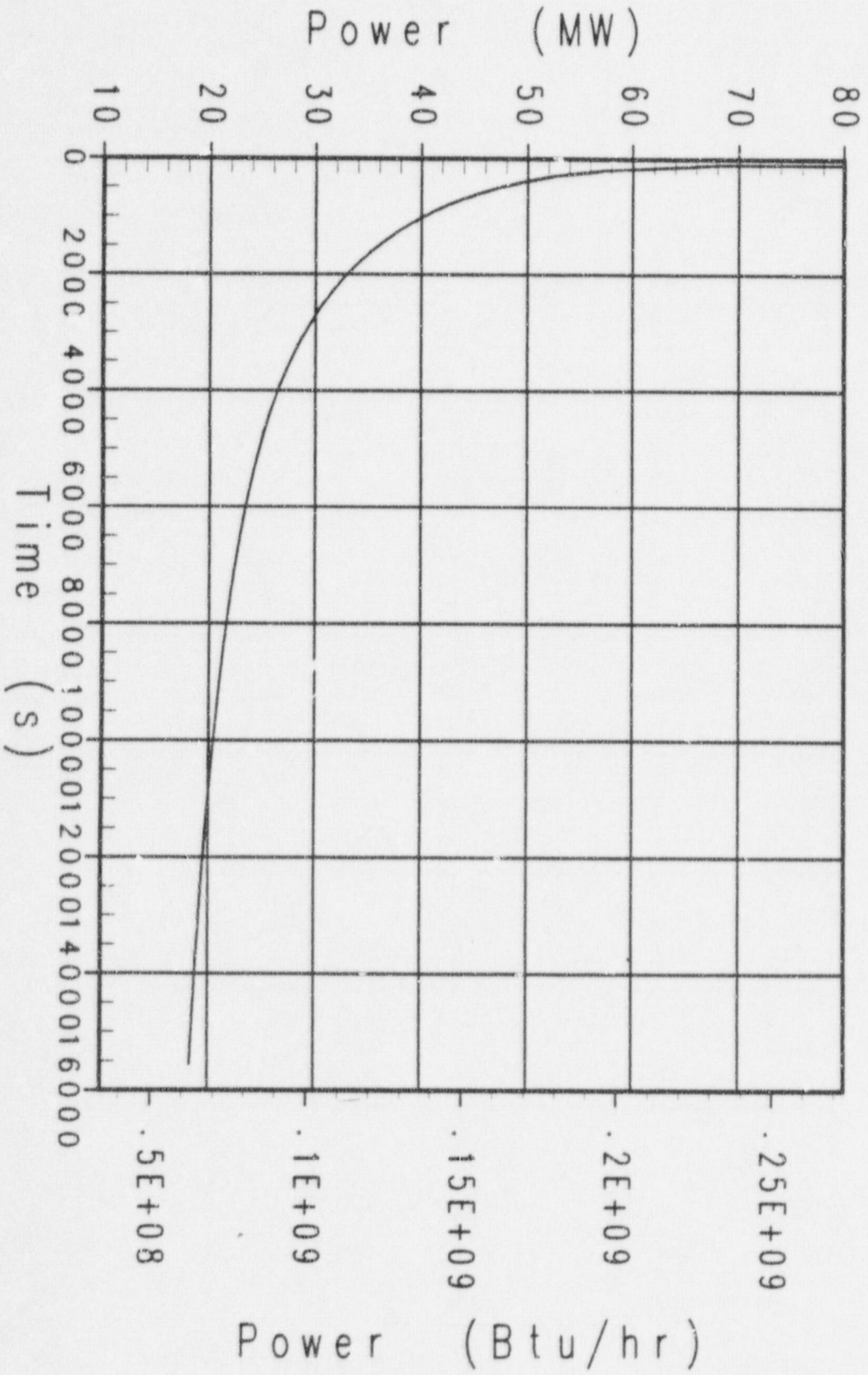

Case 94d AP600 Success Criteria MAAP4 Analysis
PRHR Heat Removal Rate

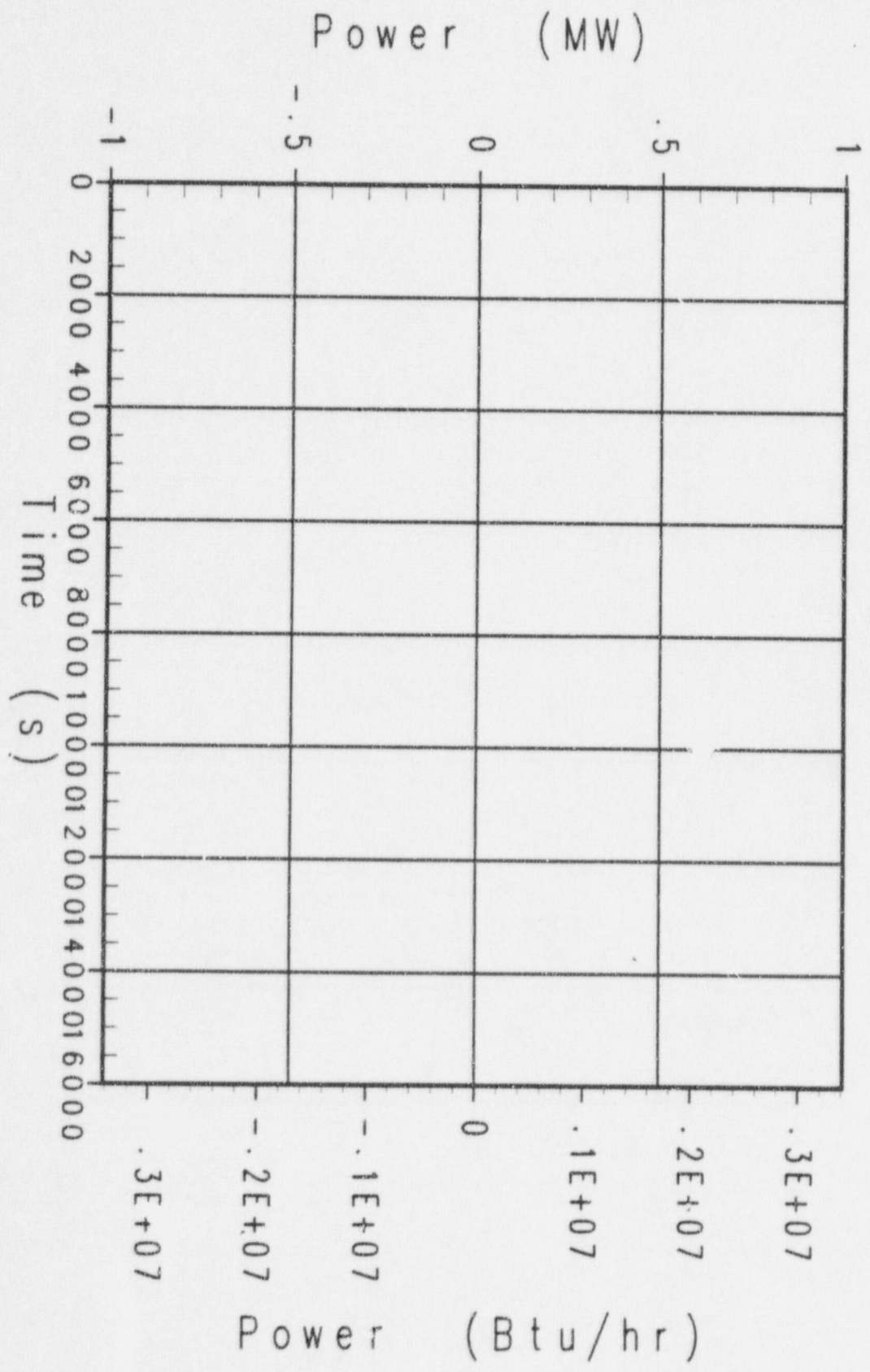

Case g4d AP600 Success Criteria MAAP4 Analysis
Peak Temperature in the Core

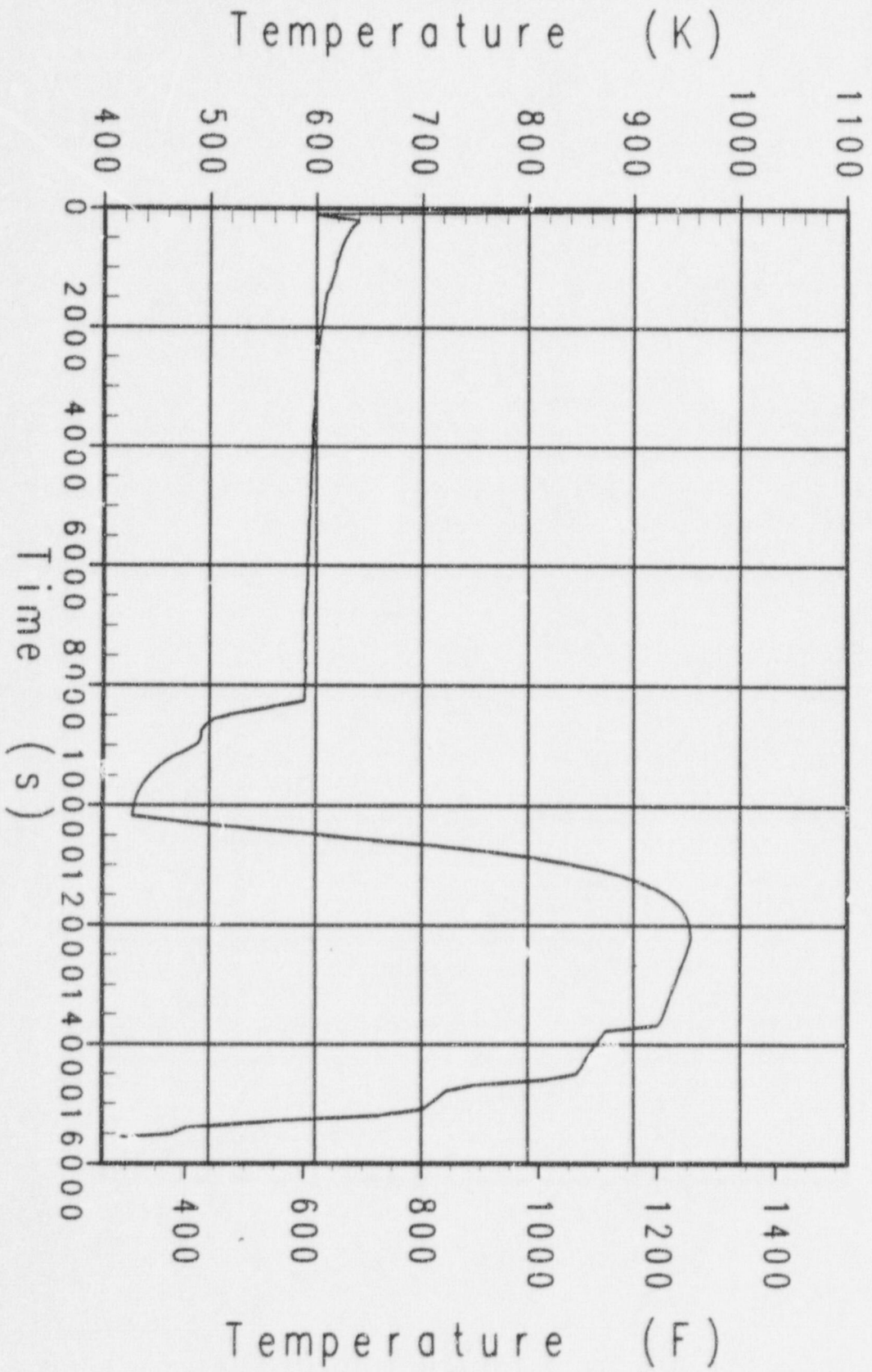

Case g4d AP600 Success Criteria MAAP4 Analysis
Cold Leg Water Temperature

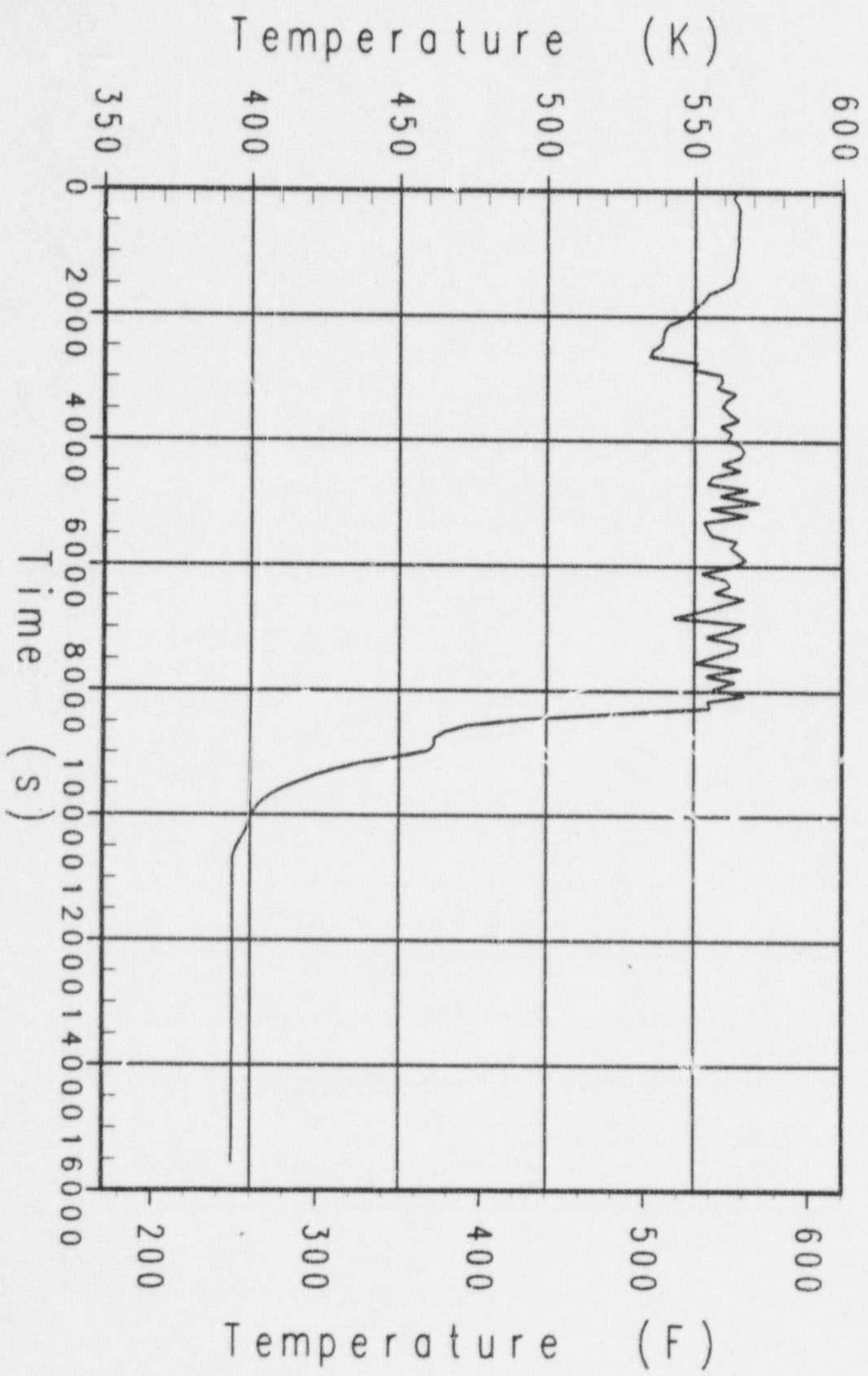

Cose g4d AP600 Success Criteria MAAp4 Analysis
Core Water Temperature

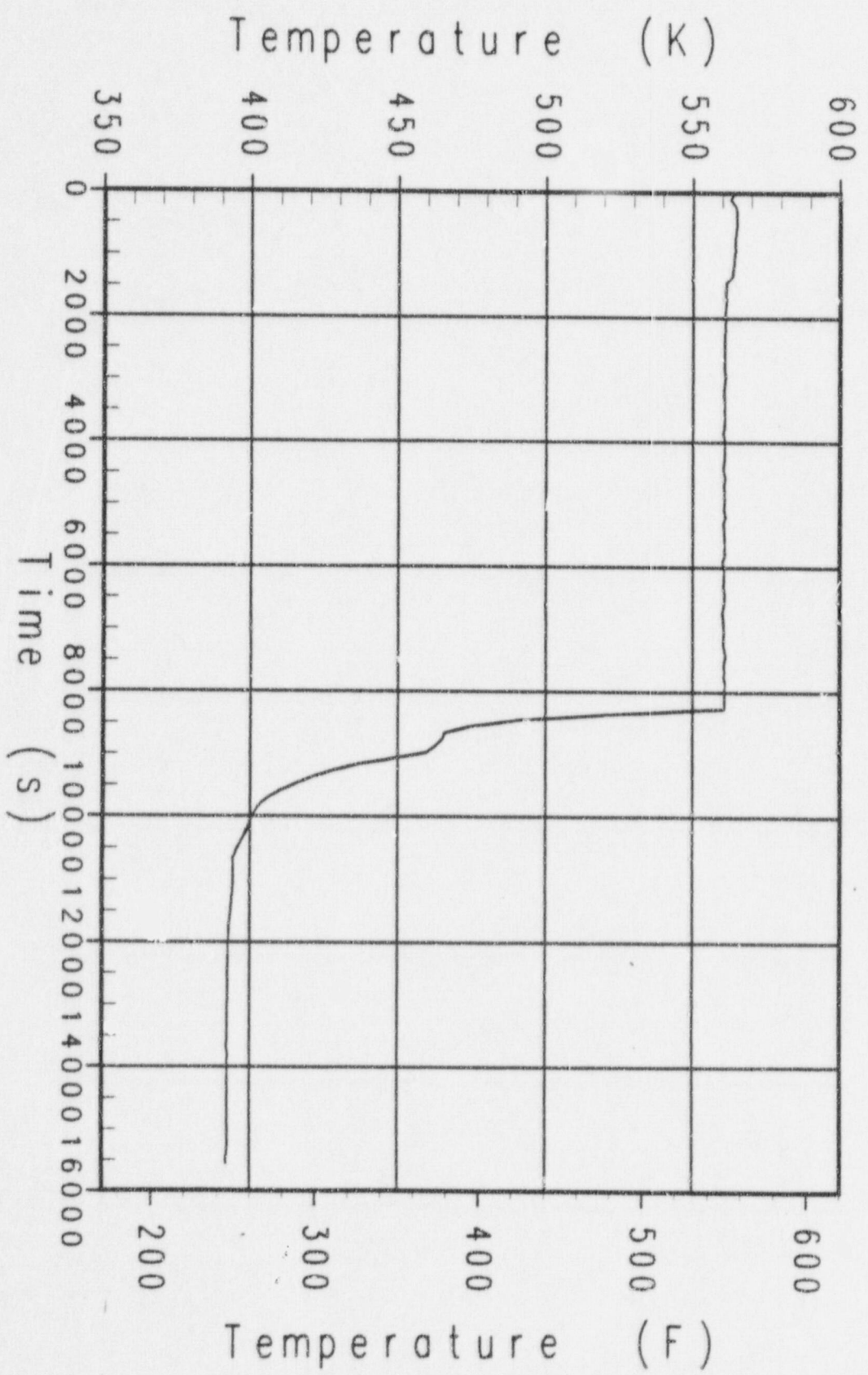

Case 94d AP600 Success Criteria MAAP4 Analysis
RPV Downcomer Water Temperature

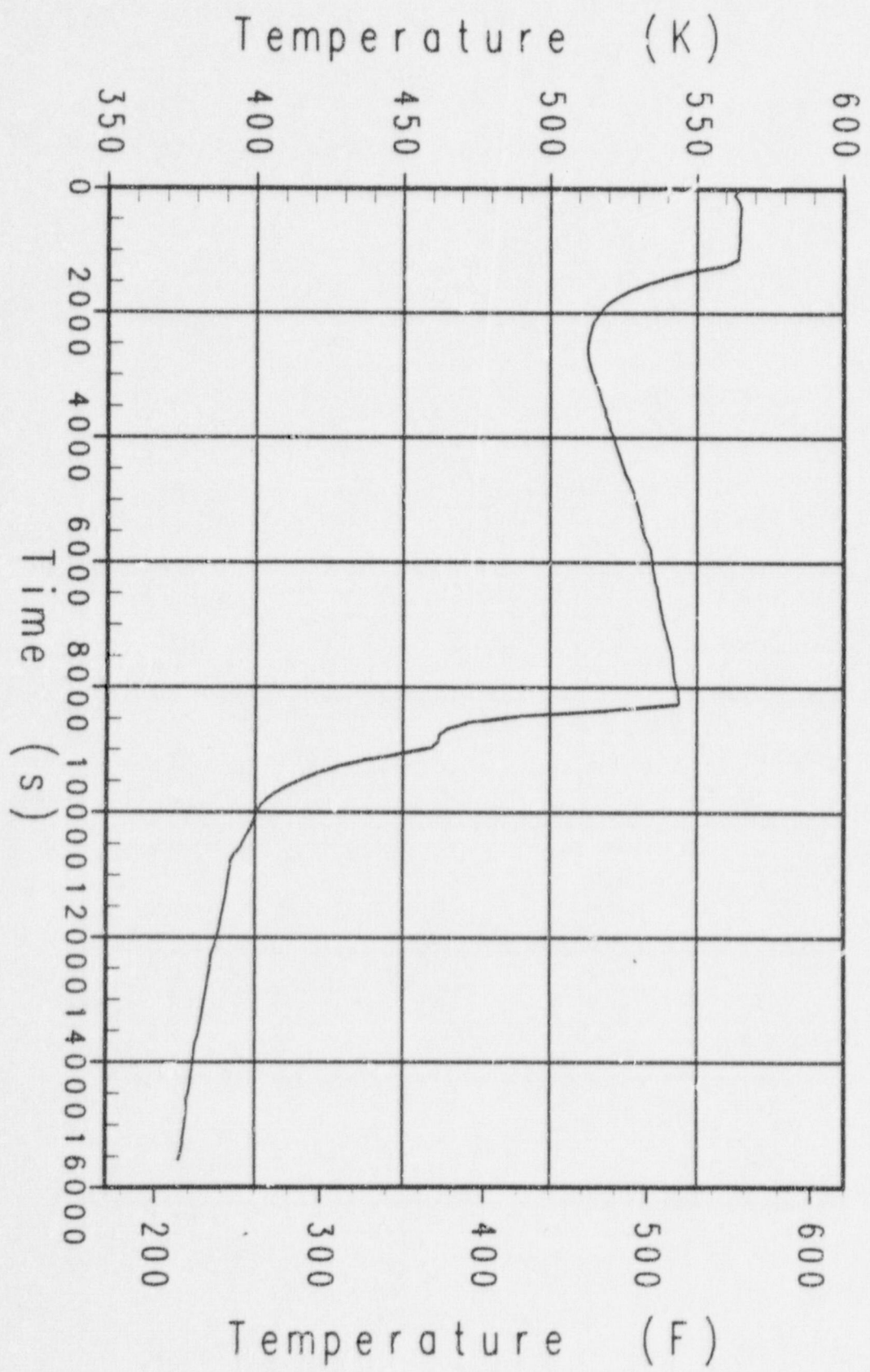

Case 94d AP600 Success Criteria MAAP4 Analysis
IRWST Water Temperature

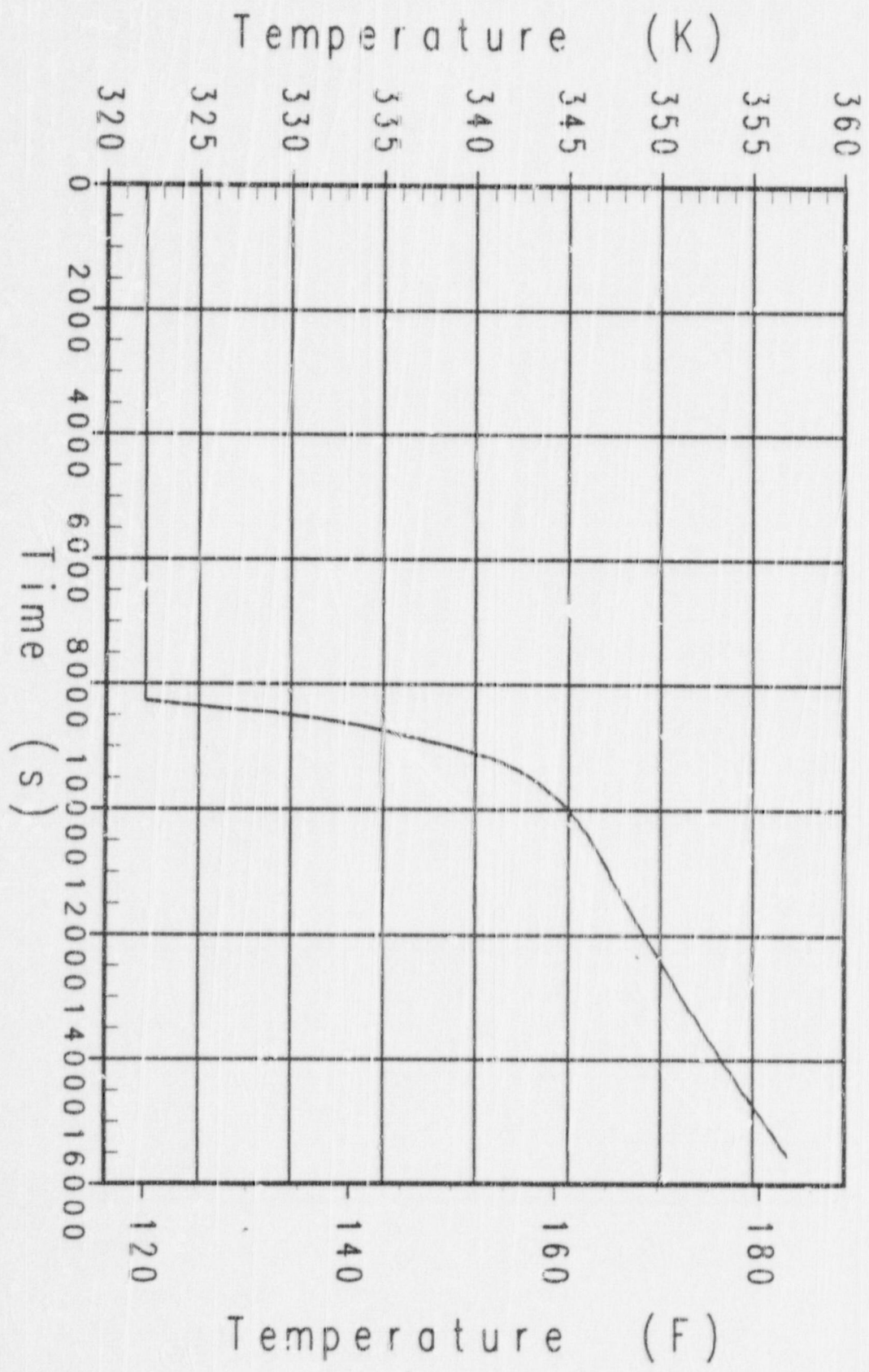

Case g4d AP600 Success Criteria MAAP4 Analysis
Accumulator and NRHR Injection Flowrate

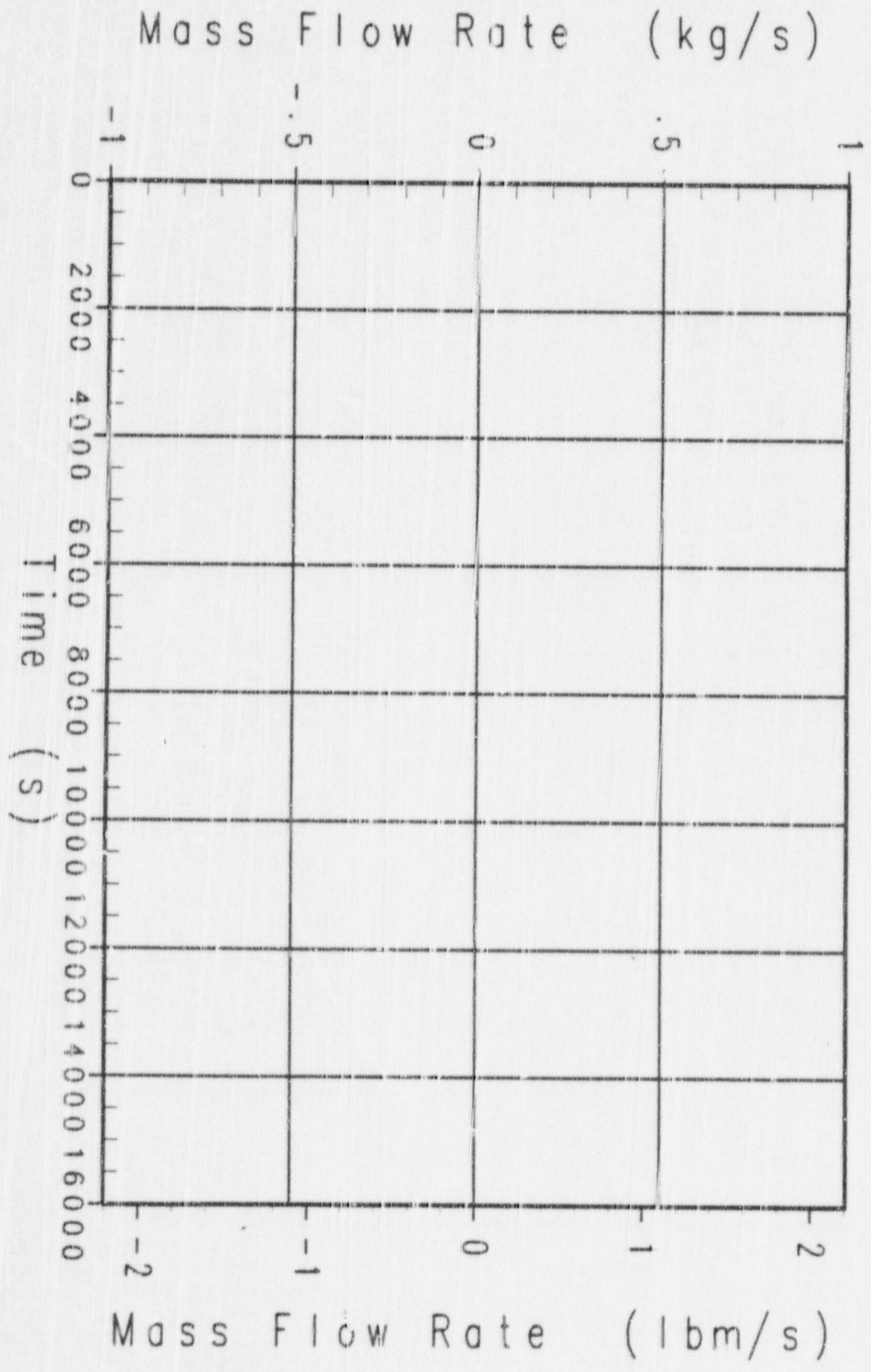

Case g4d AP600 Success Criteria MAAP4 Analysis
RCS Break Gas Flowrate

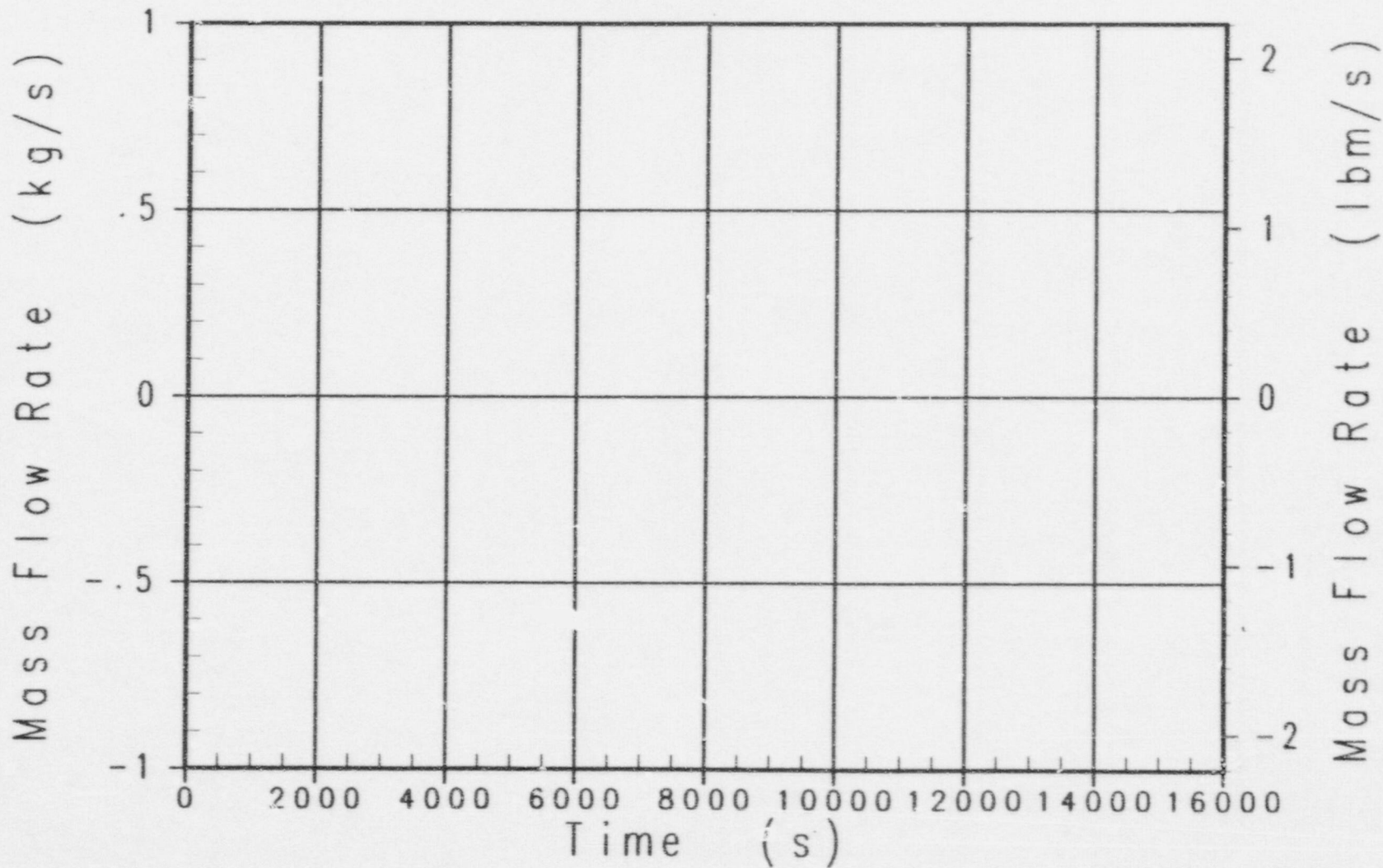

Case g4d AP600 Success Criteria MAAp4 Analysis
ADS Stage 4 Gas Flowrate

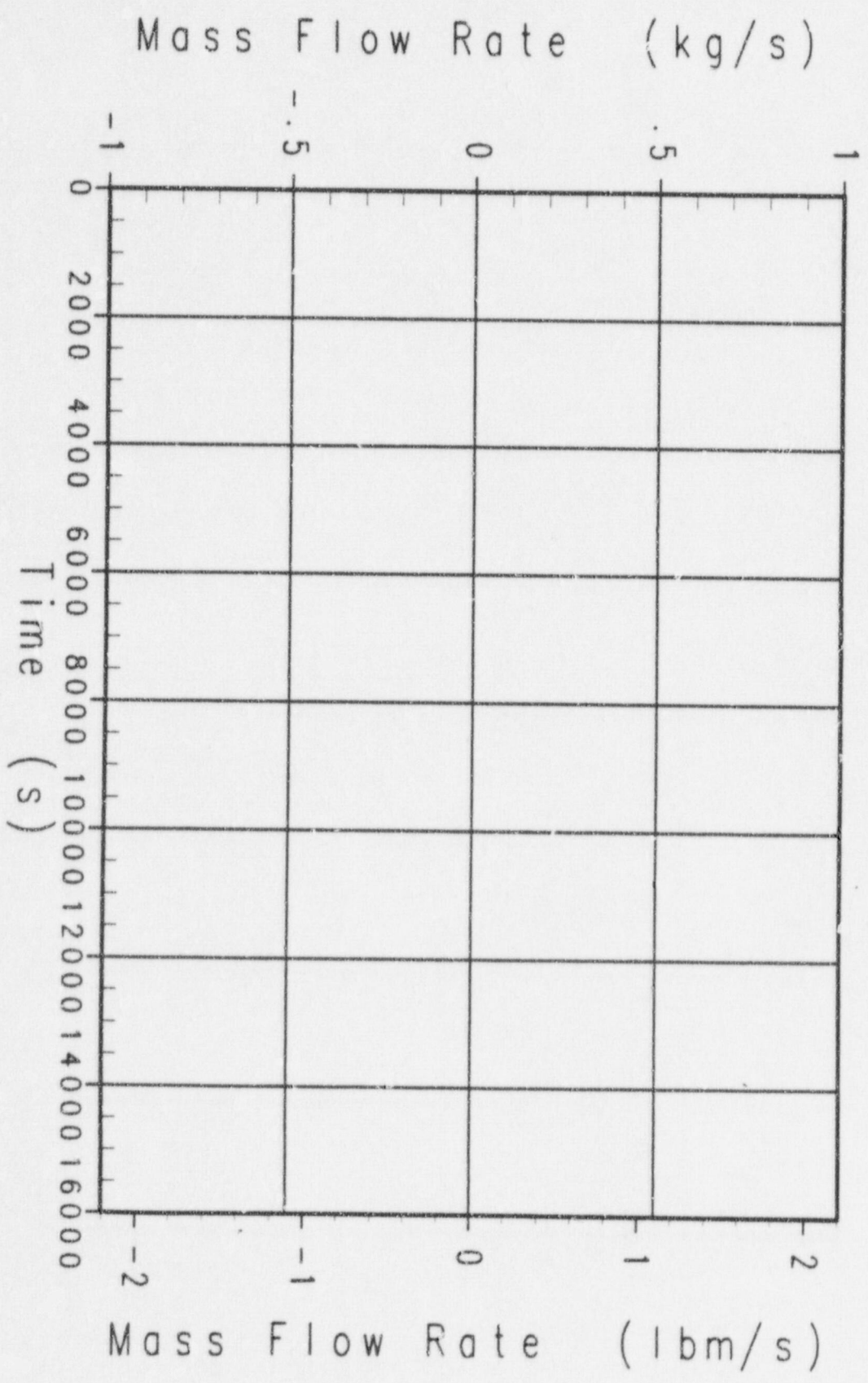

Case 94d AP600 Success Criteria MAPP4 Analysis
Safety Valve and ADS Stages 1-3 Gas Flowrate

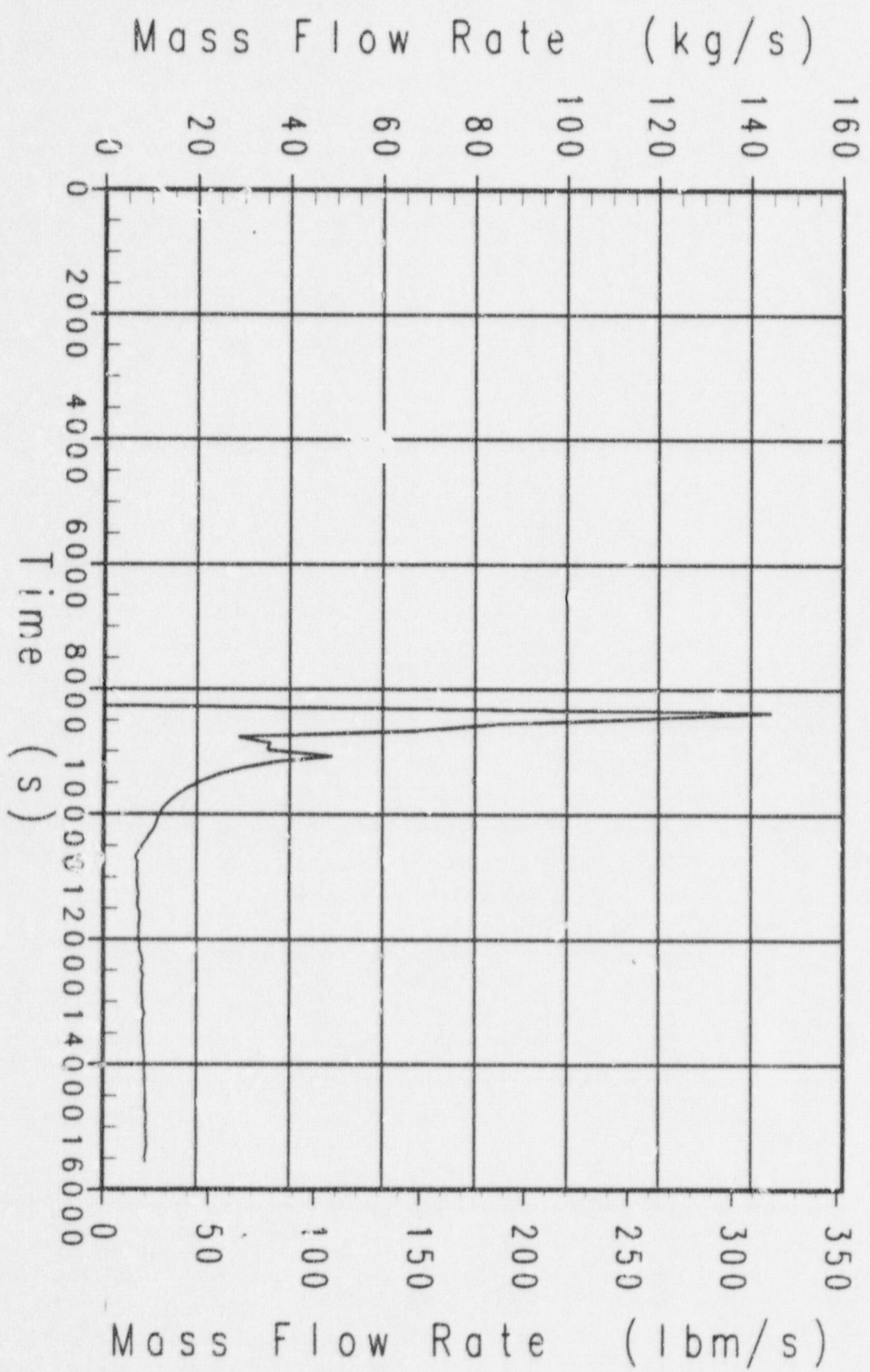

Case g4d AP600 Success Criteria MAAP4 Analysis
RCS Break Liquid Flowrate

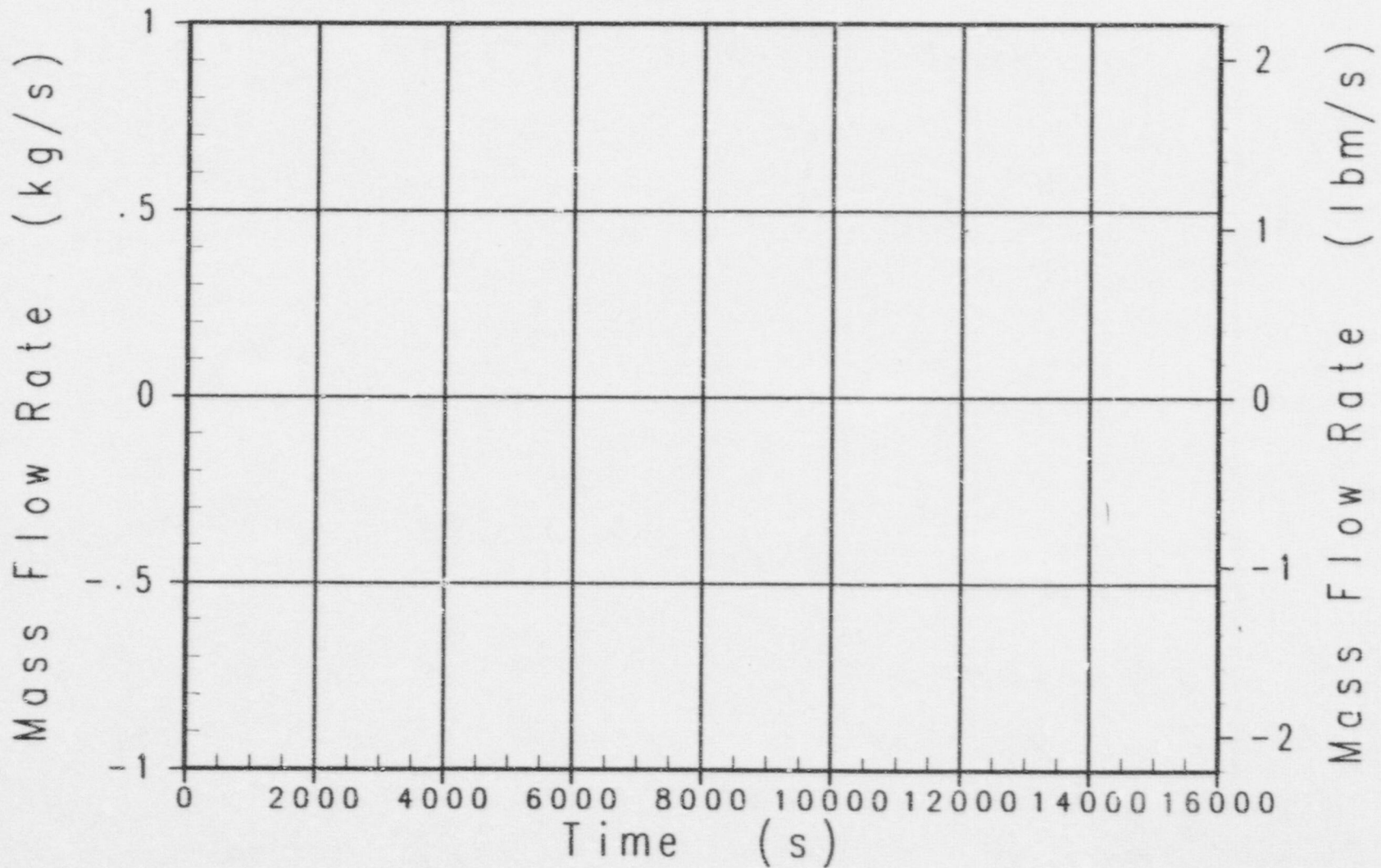

Case g4d AP600 Success Criteria MAAp4 Analysis
ADS Stage 4 Liquid Flowrate

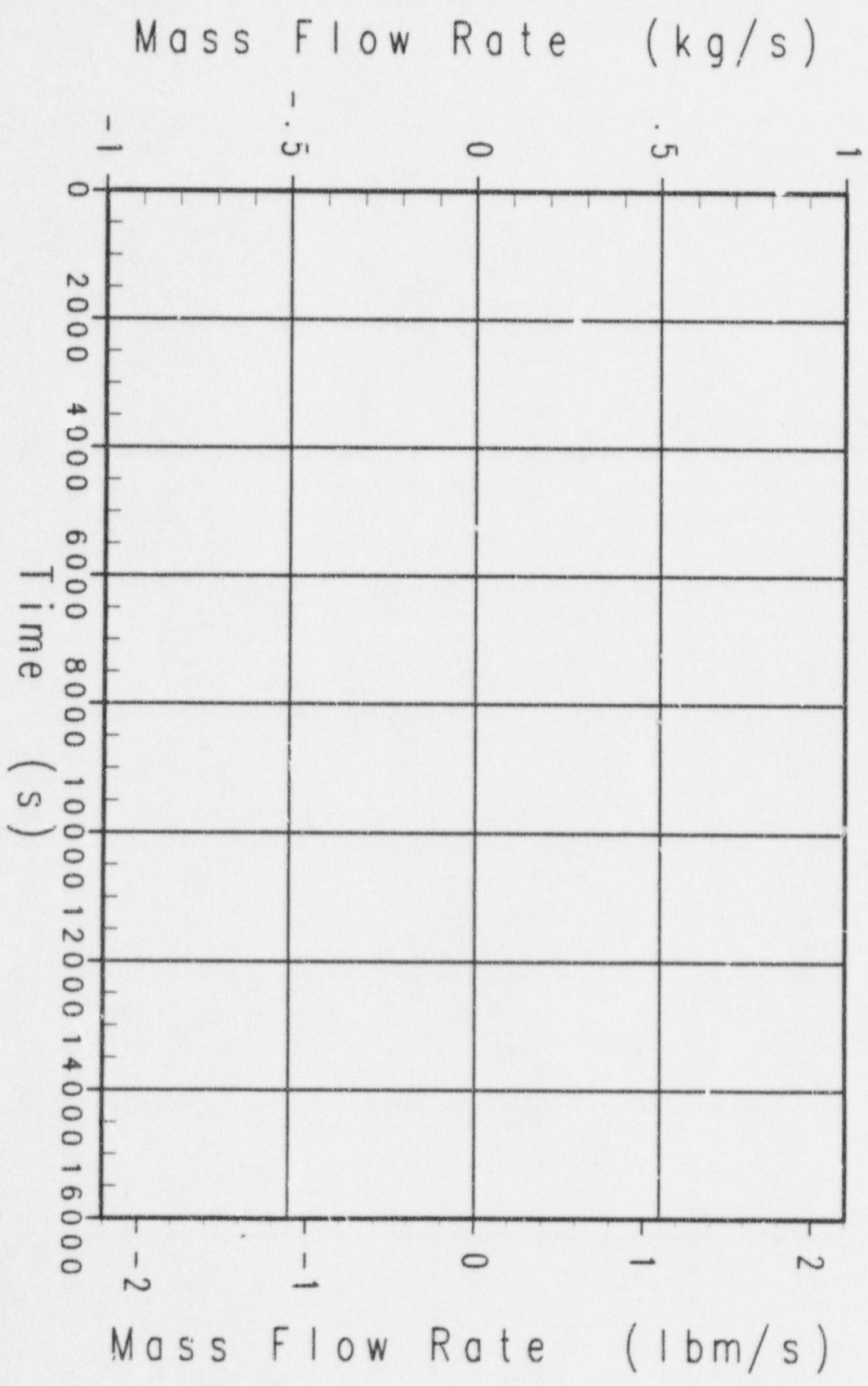

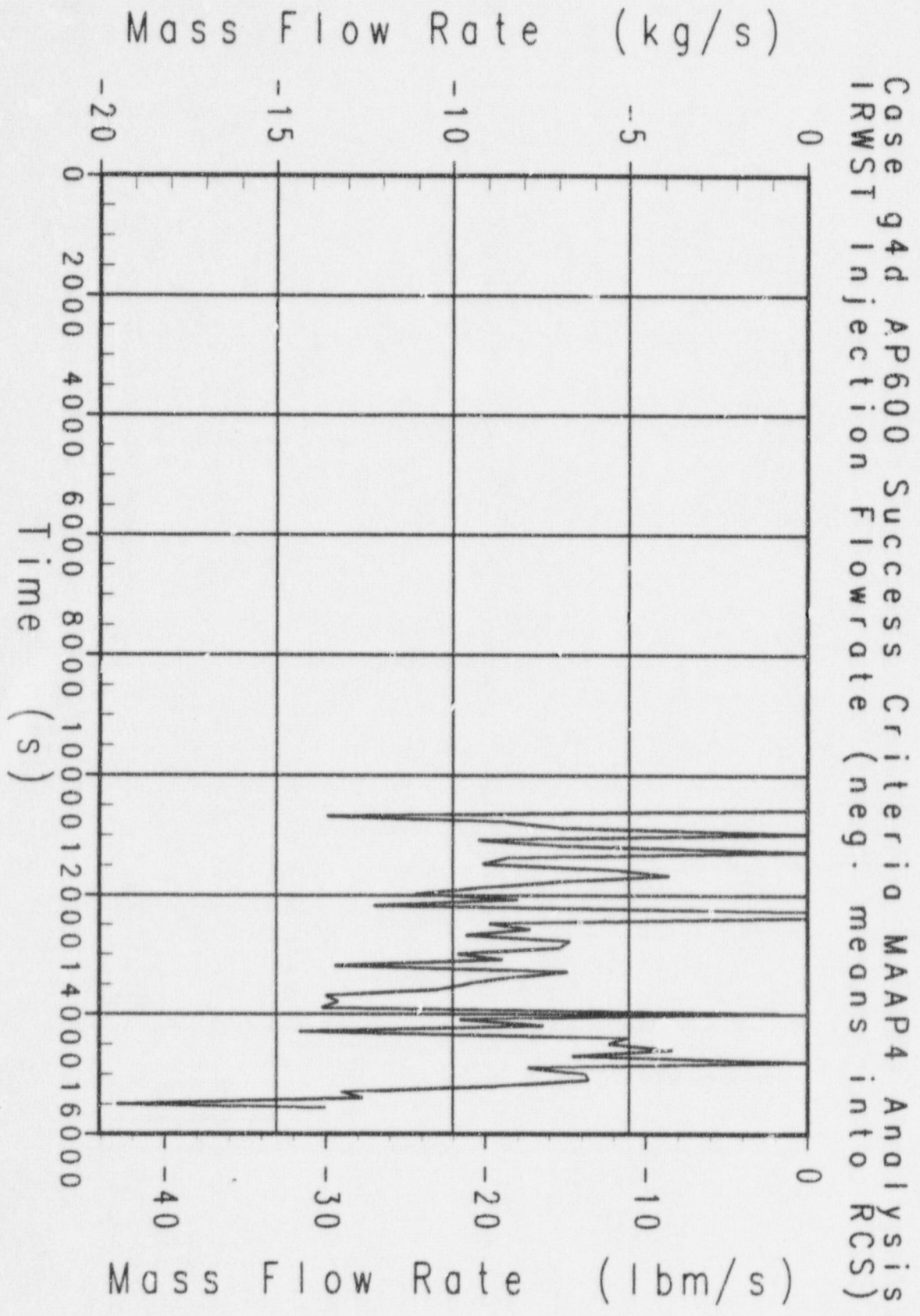

Case g4d AP600 Success Criteria MAAP4 Analysis
CMT-1 Injection Flowrate

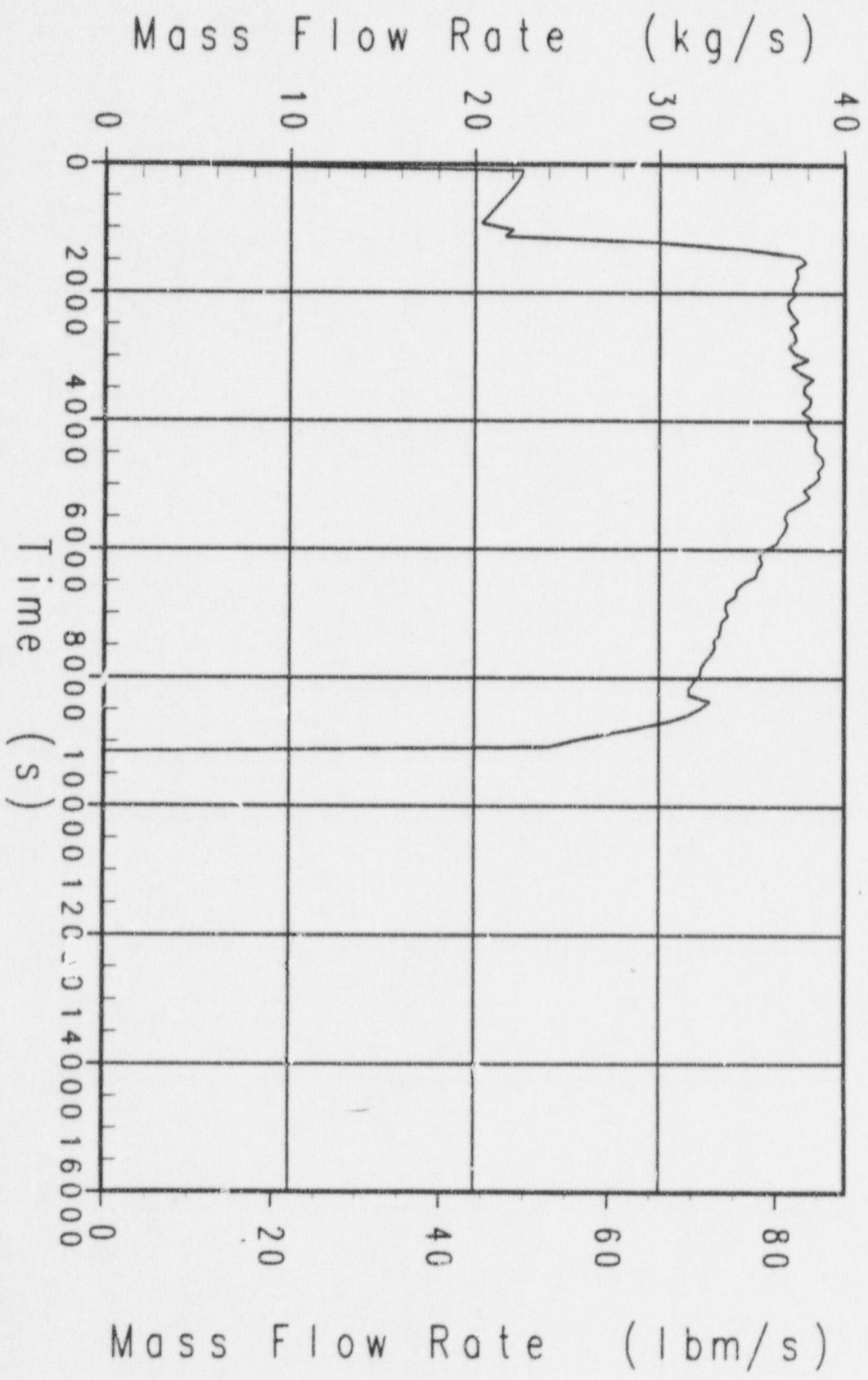

Case g4d AP600 Success Criteria MAPP4 Analysis
Safety Valve and ADS Stages 1-3 Liquid Flowrate

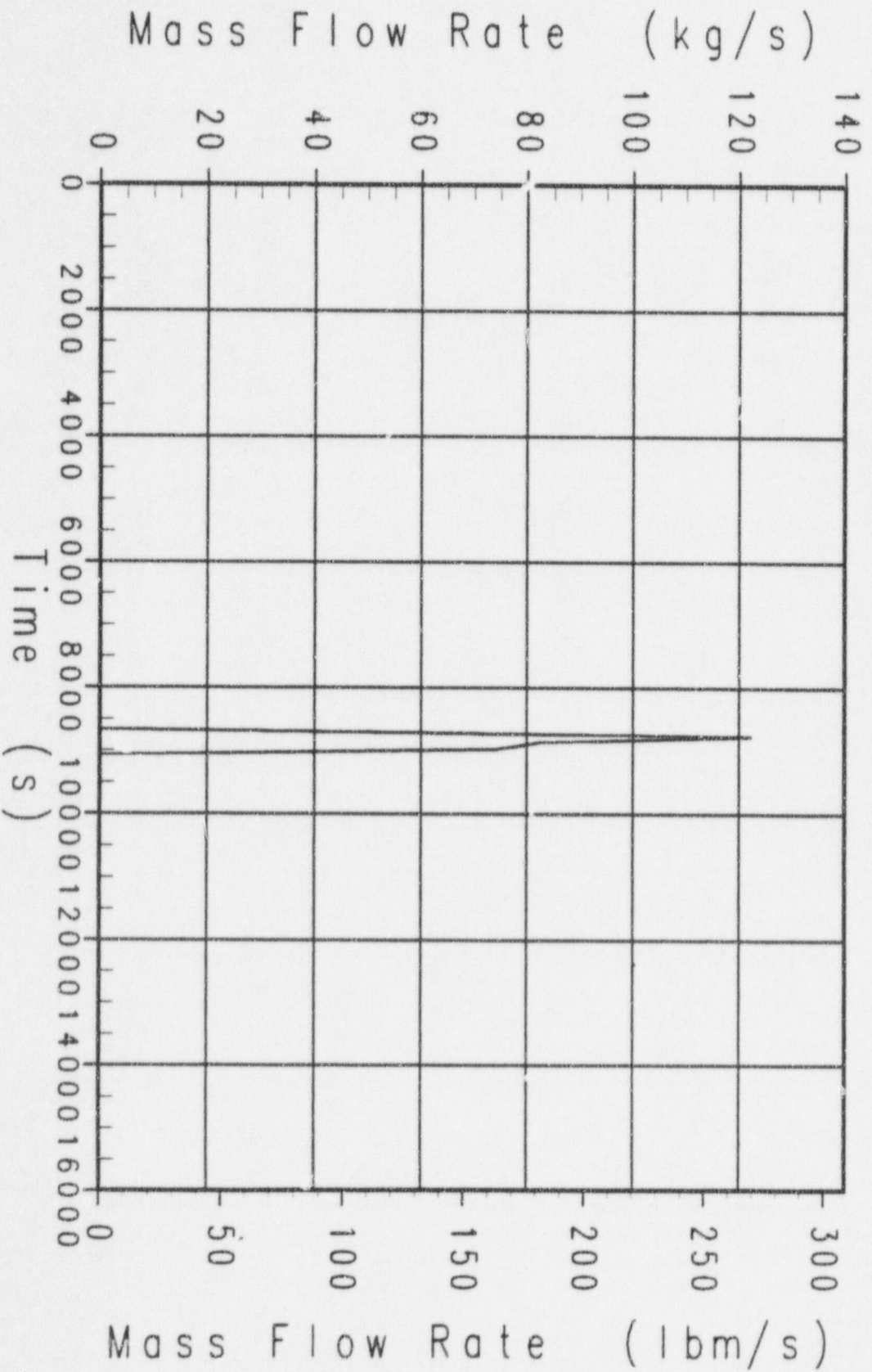

Case g4d AP600 Success Criteria MAAP4 Analysis
CMT-1 Water Level

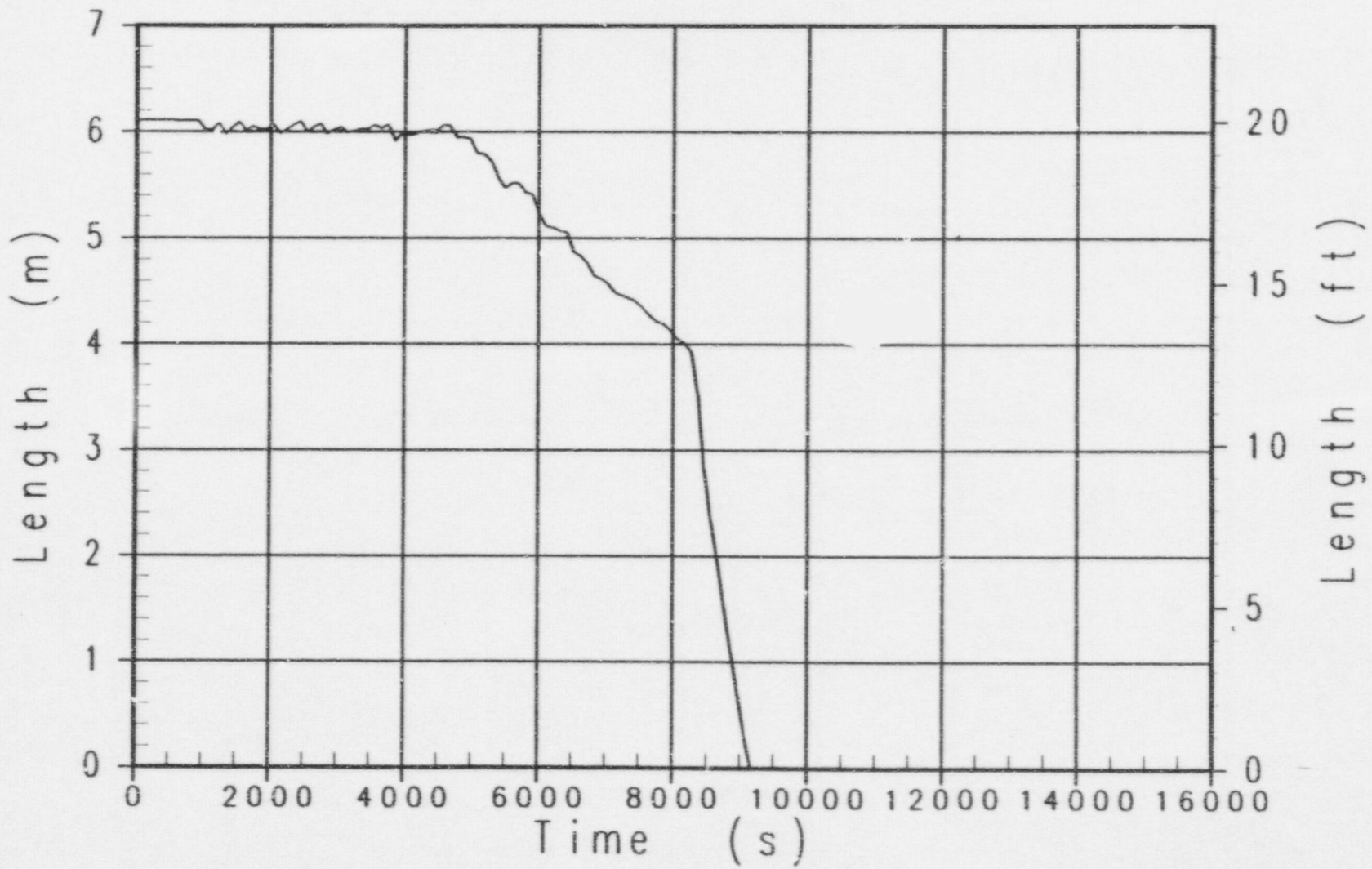

Case g4d AP600 Success Criteria MAAP4 Analysis
Pressurizer Water Level (From Pzr Bottom)

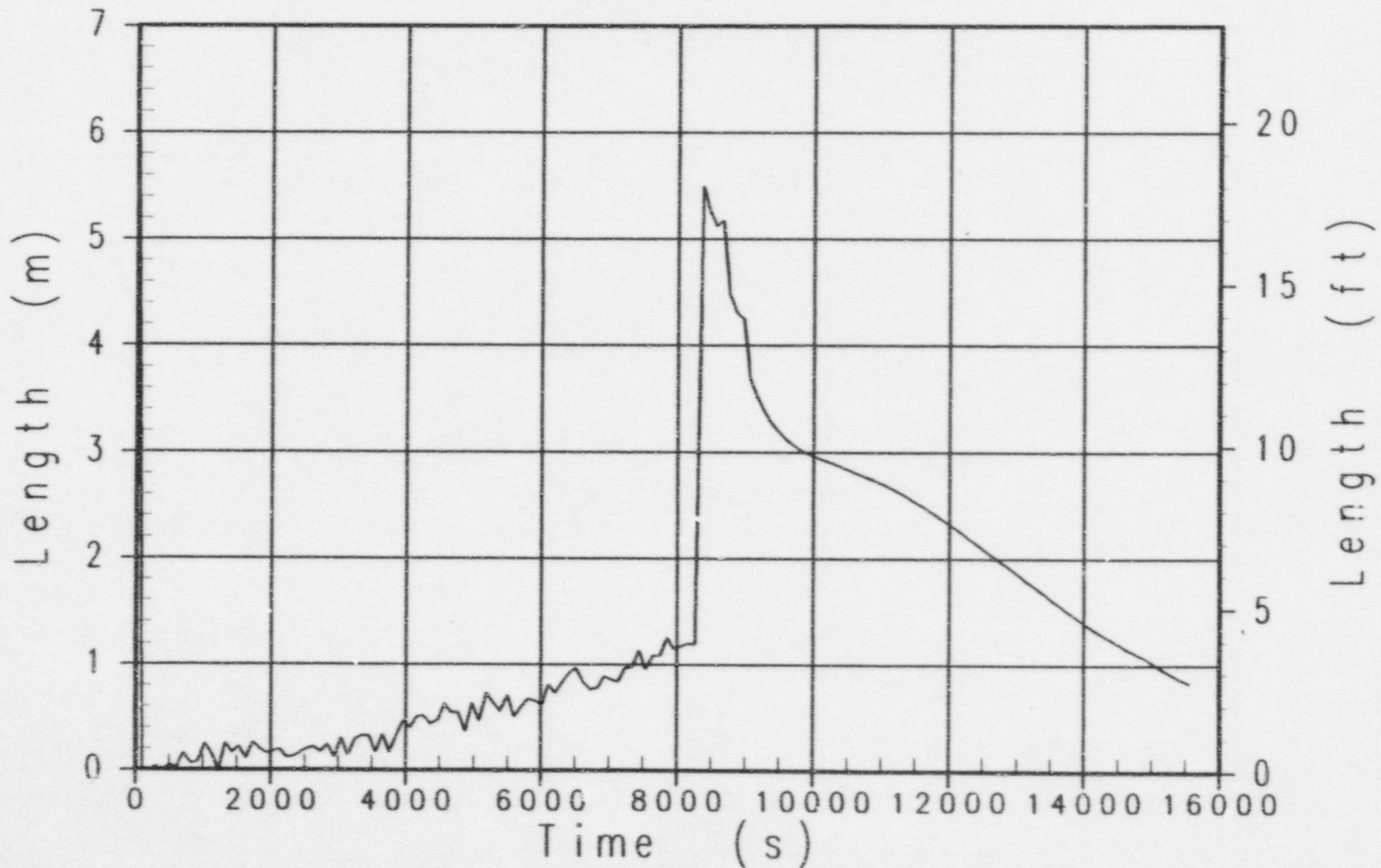

Case g4d2 AP600 Success Criteria MAAP4 Analysis
Broken Loop Steam Generator Pressure

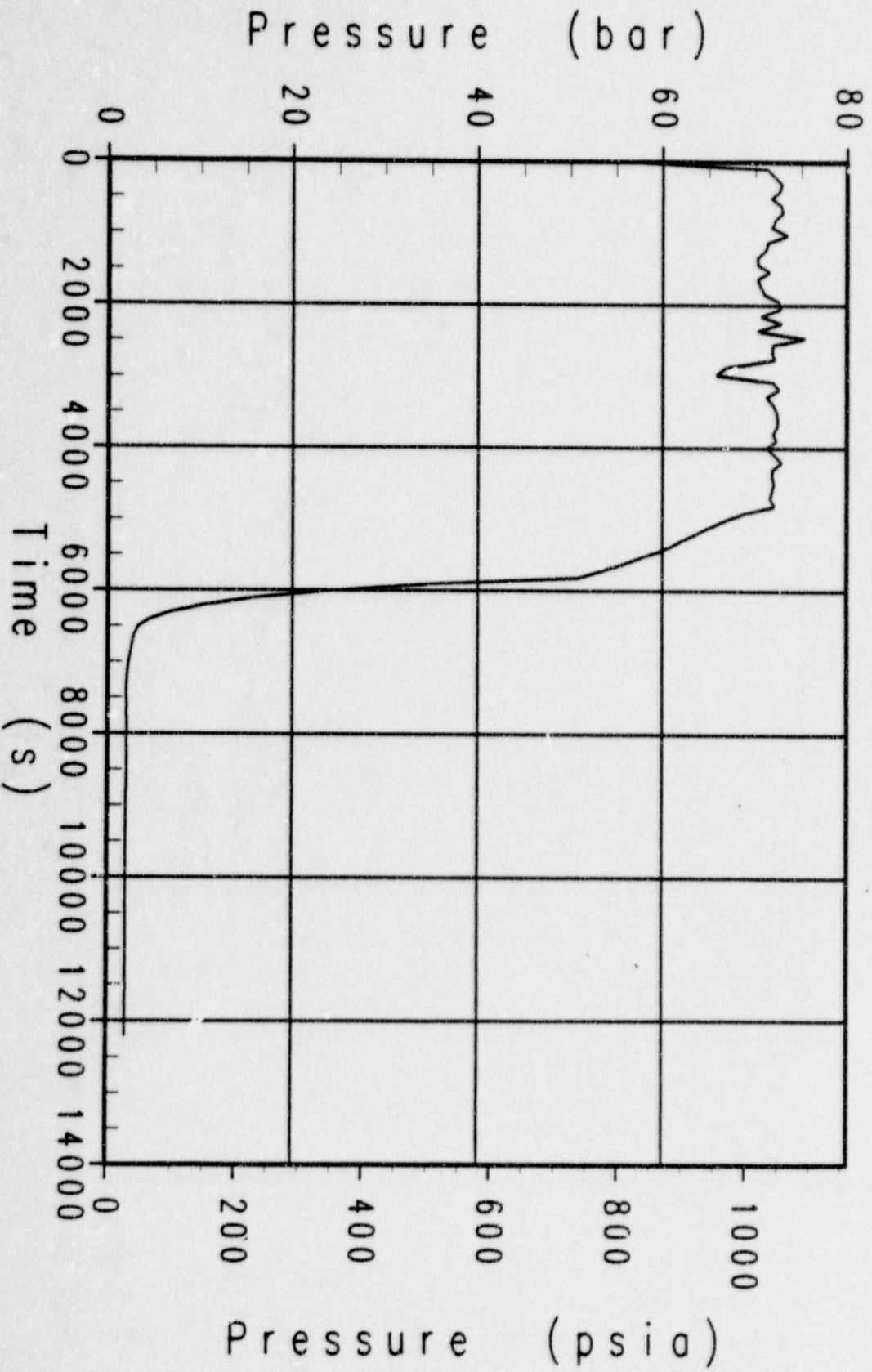

Case 94d2 AP600 Success Criteria MAAP4 Analysis
Primary System Pressure

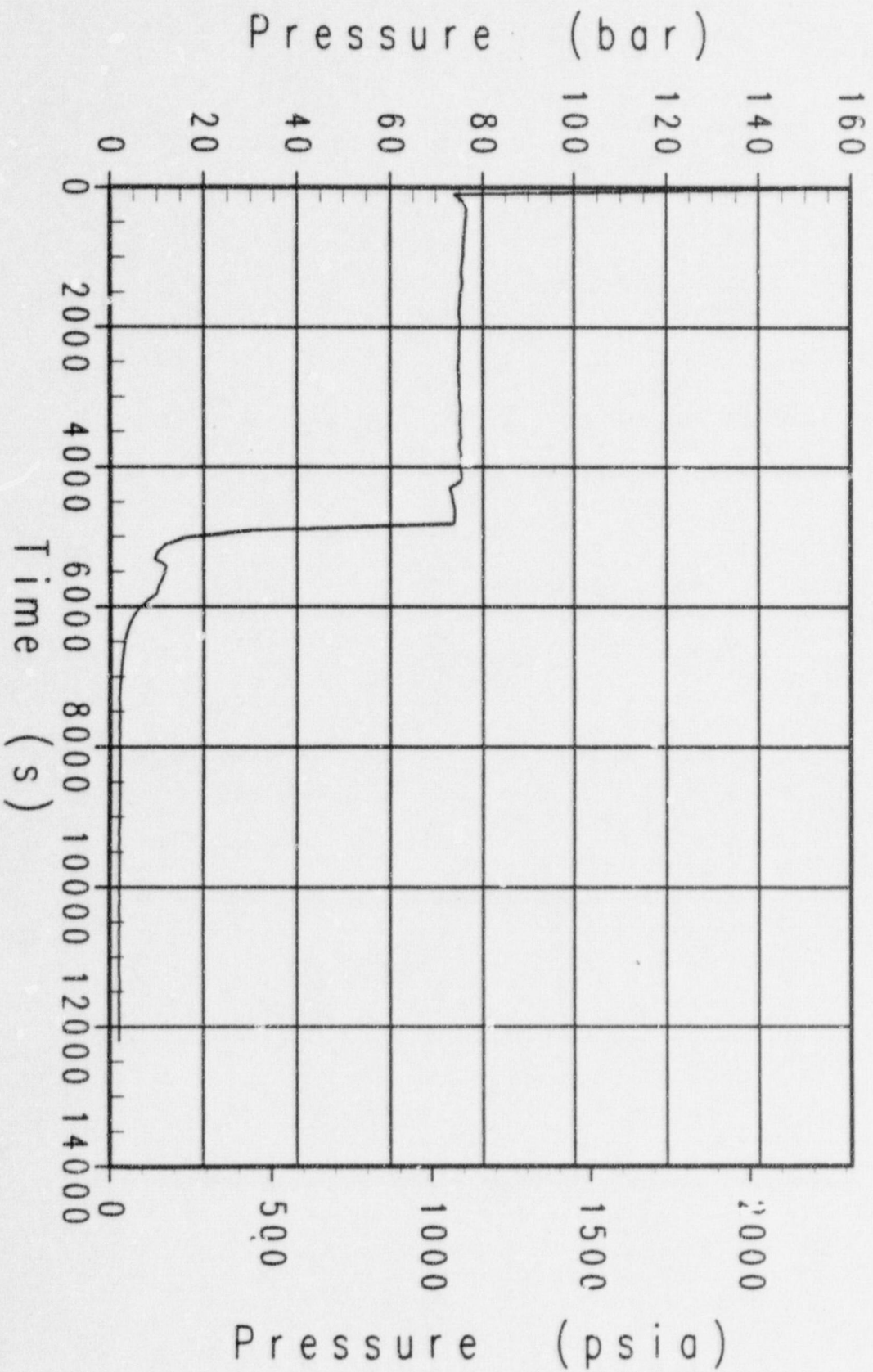

Case g4d2 AP600 Success Criteria MAAP4 Analysis
Containment Pressure

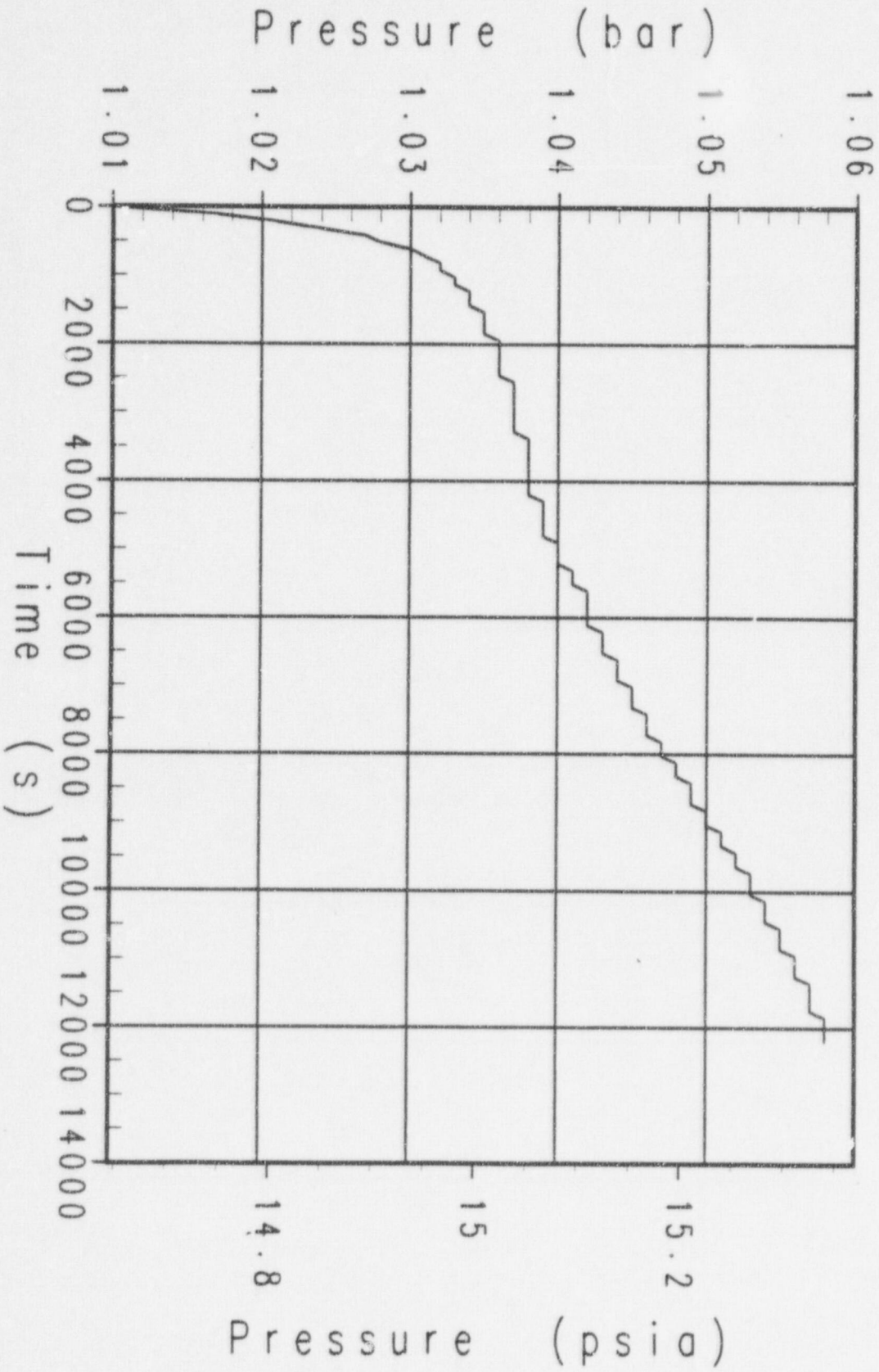

Case g4d2 AP600 Success Criteria MAAP4 Analysis
Unbroken Loop Steam Generator Pressure

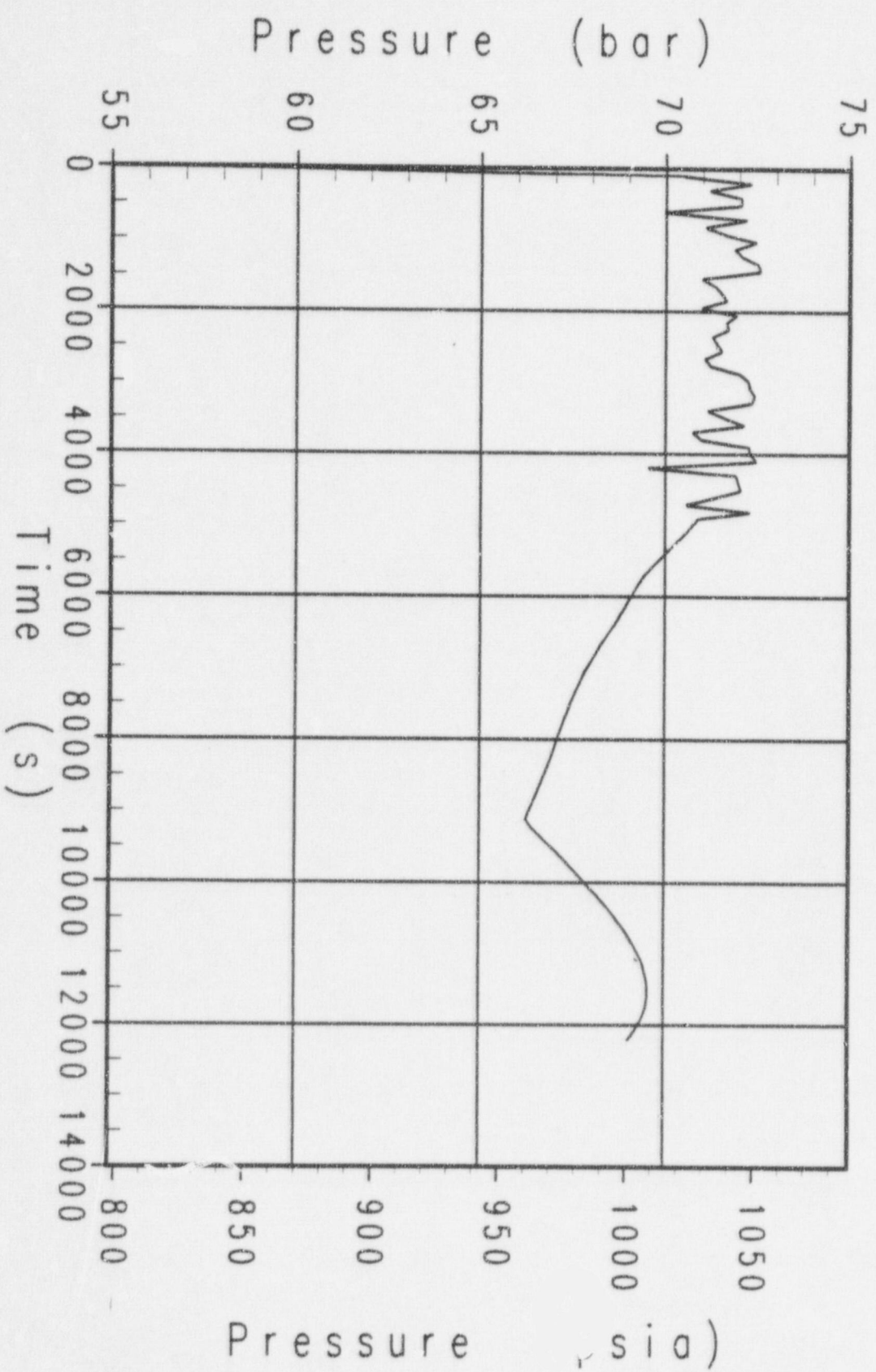

Case g4d2 AP600 Success Criteria MAAP4 Analysis
Decay Power

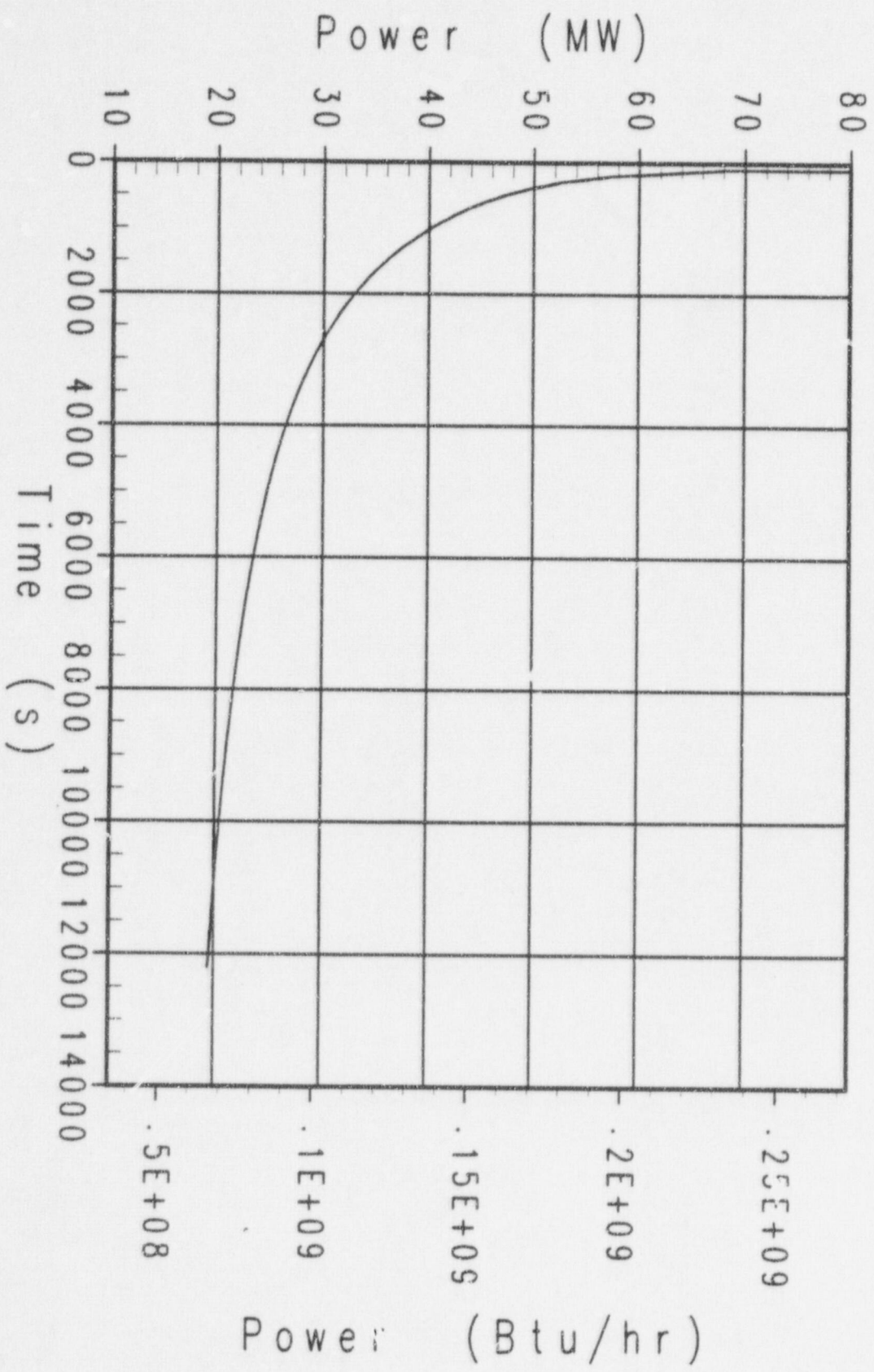

Case g4d2 AP600 Success Criteria MAAP4 Analysis
PRHR Heat Removal Rate

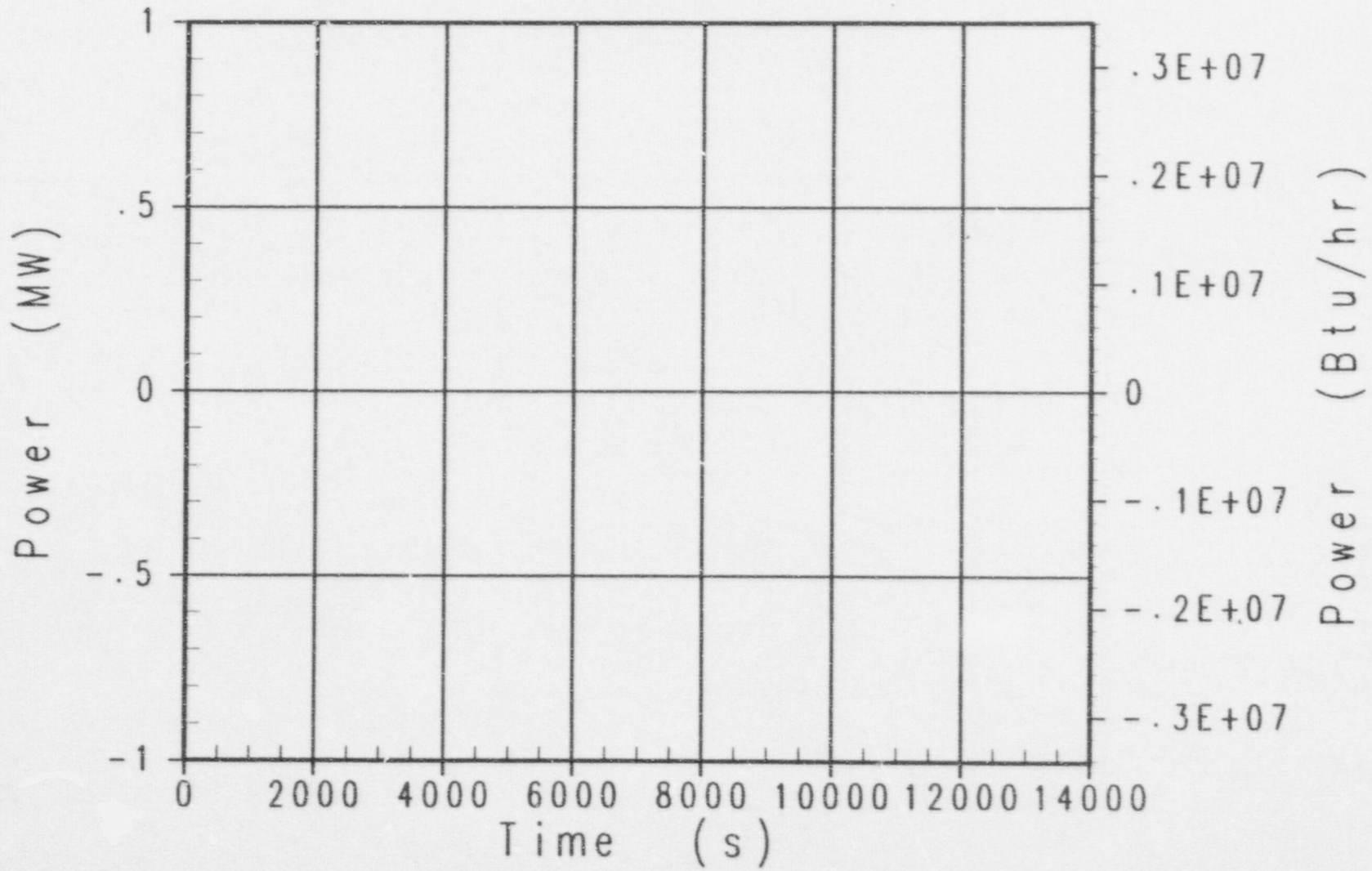

Case g4d2 AP600 Success Criteria MAAP4 Analysis
Peak Temperature in the Core

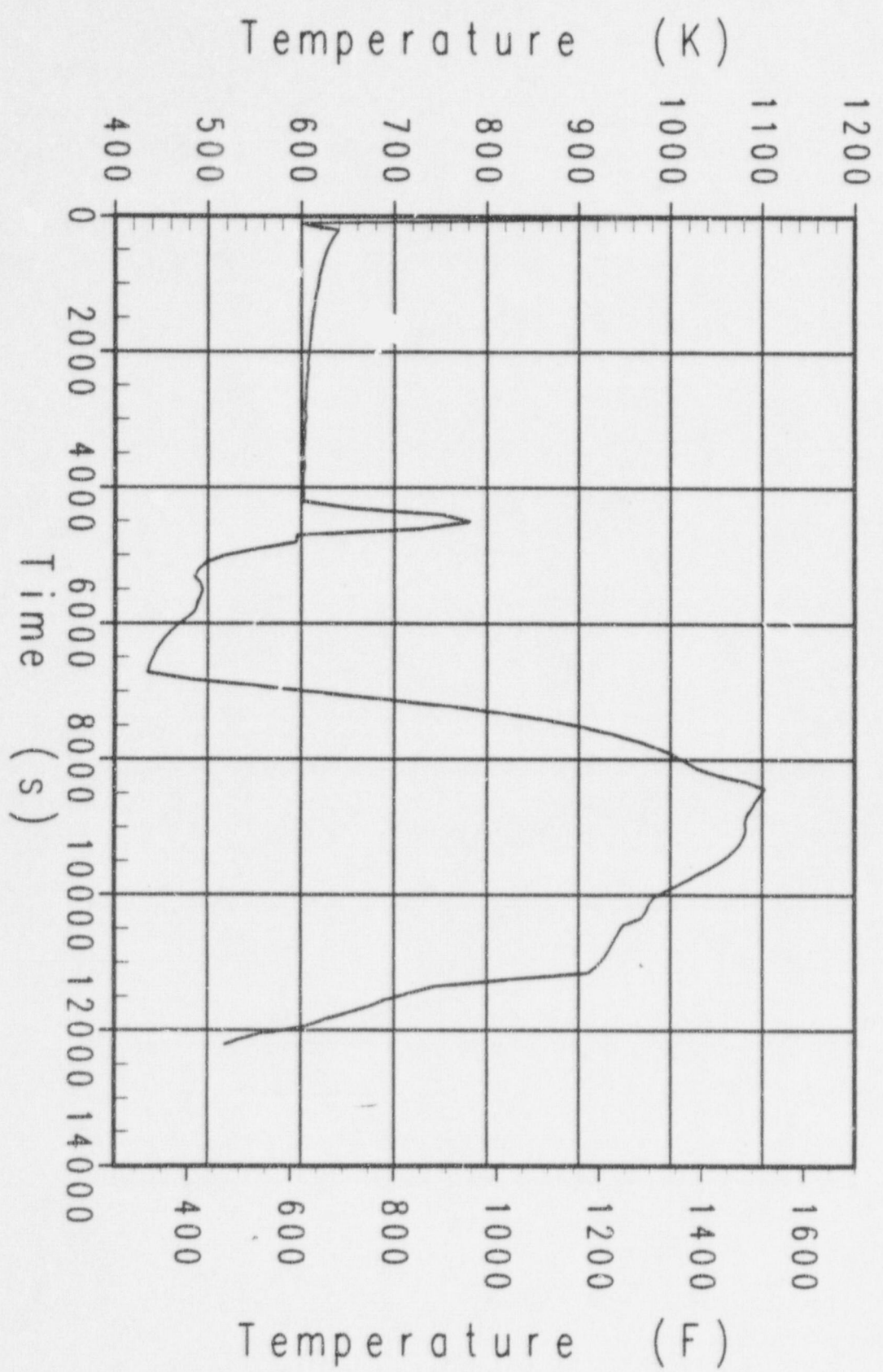

Case g4d2 AP600 Success Criteria MAAP4 Analysis
Cold Leg Water Temperature

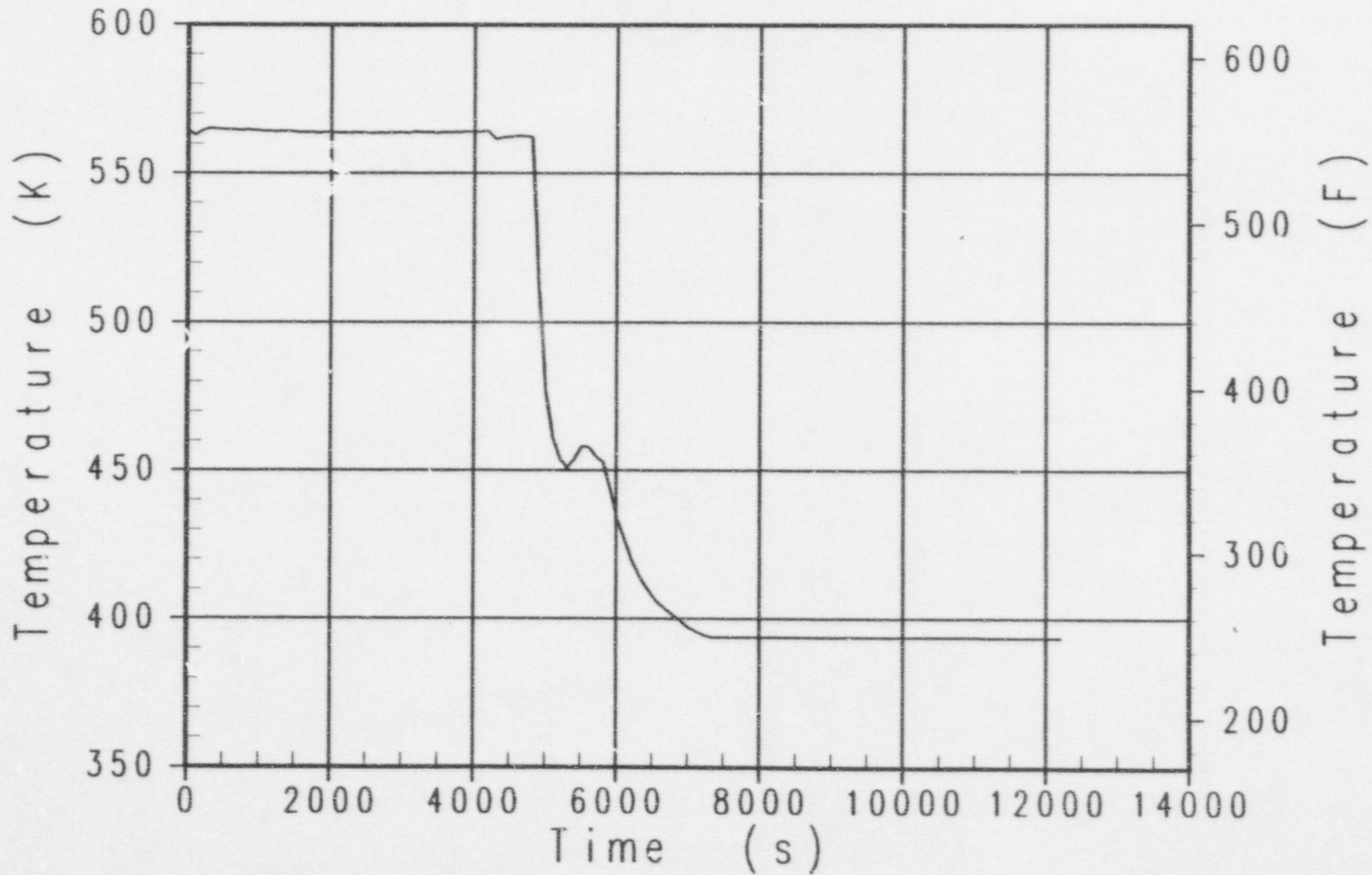

Case g4d2 AP600 Success Criteria MAAP4 Analysis
Core Water Temperature

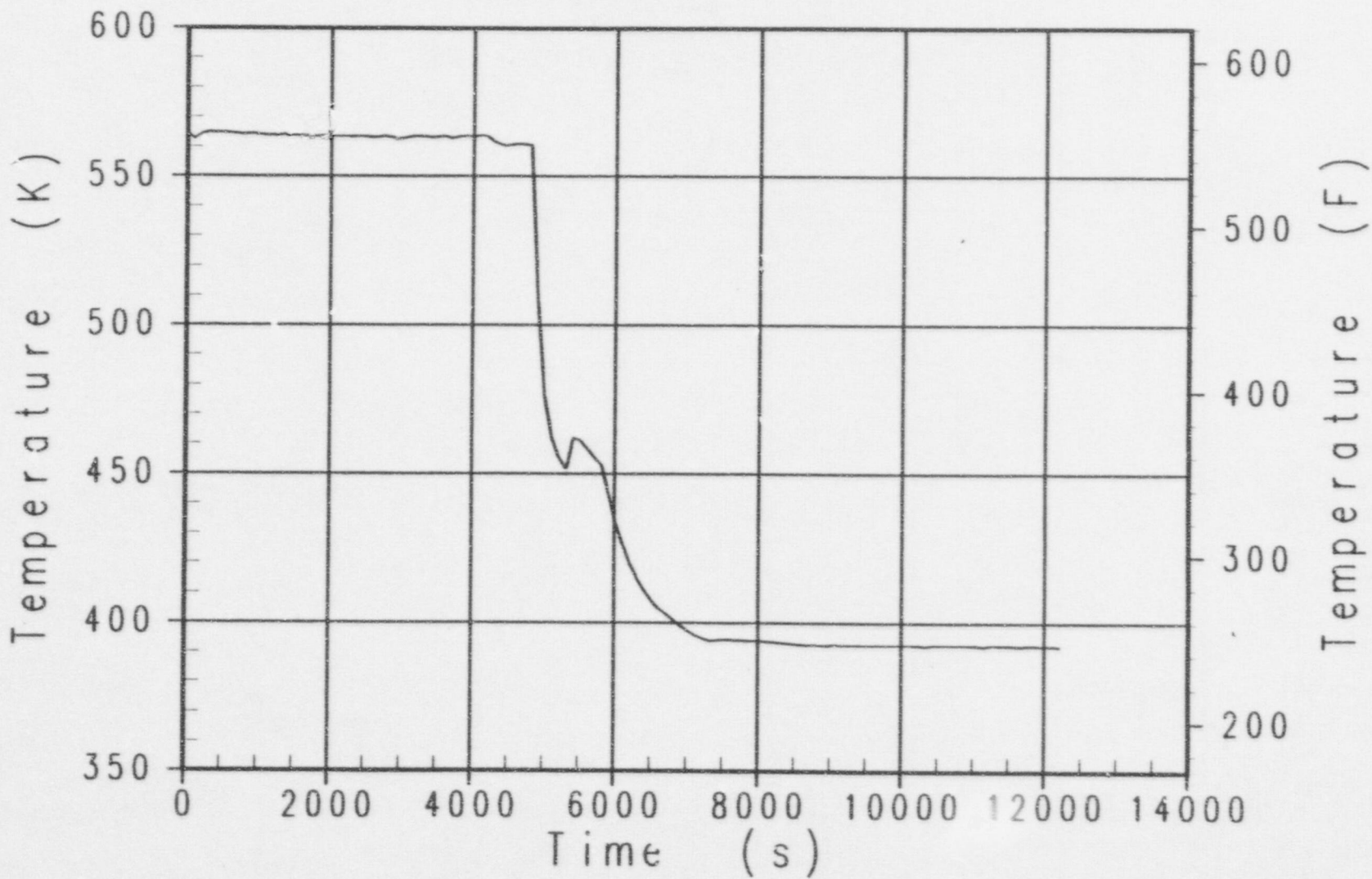

Case g4d2 AP600 Success Criteria MAAP4 Analysis
RPV Downcomer Water Temperature

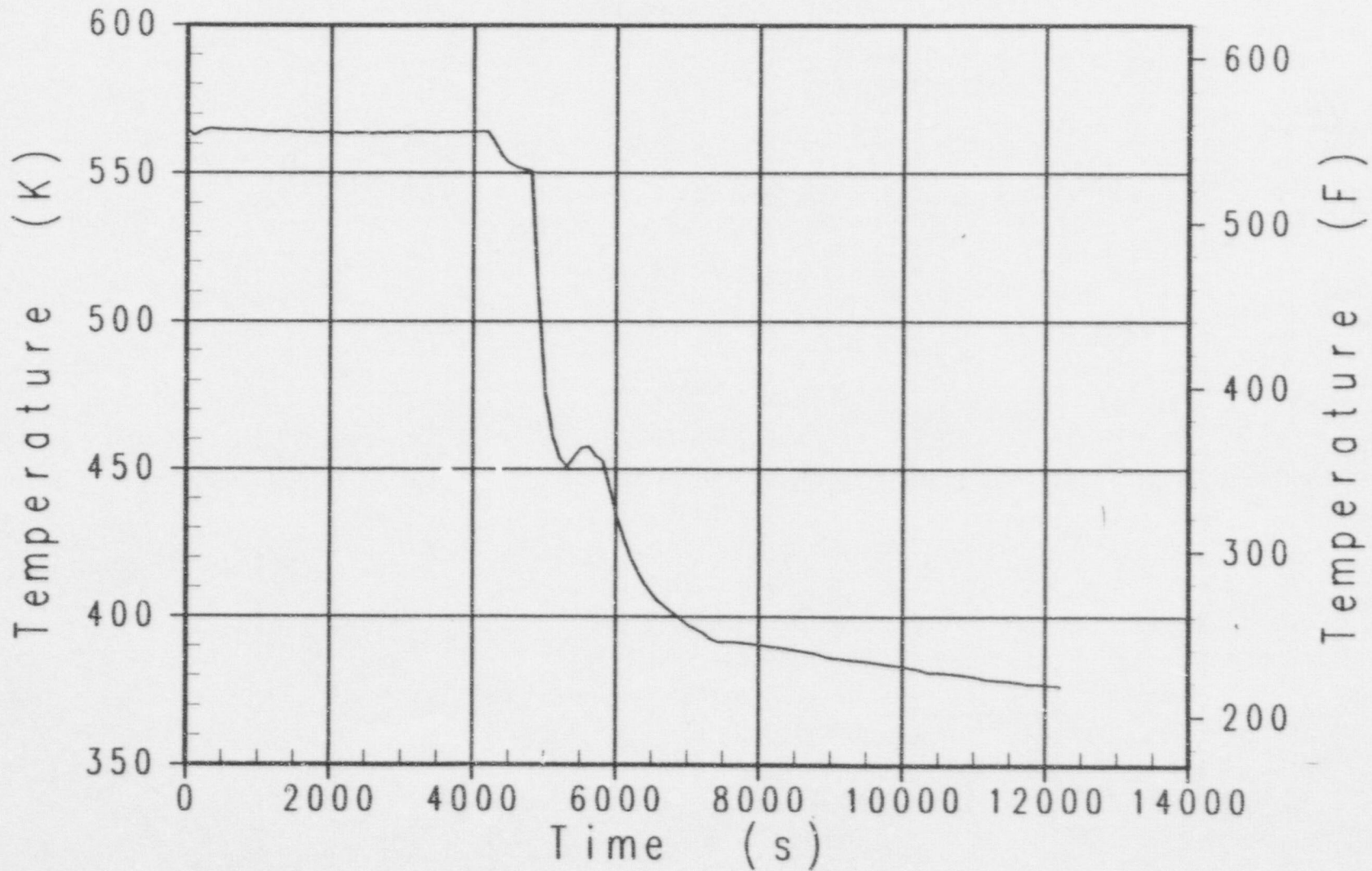

Case g4d2 AP600 Success Criteria MAAP4 Analysis
IRWST Water Temperature

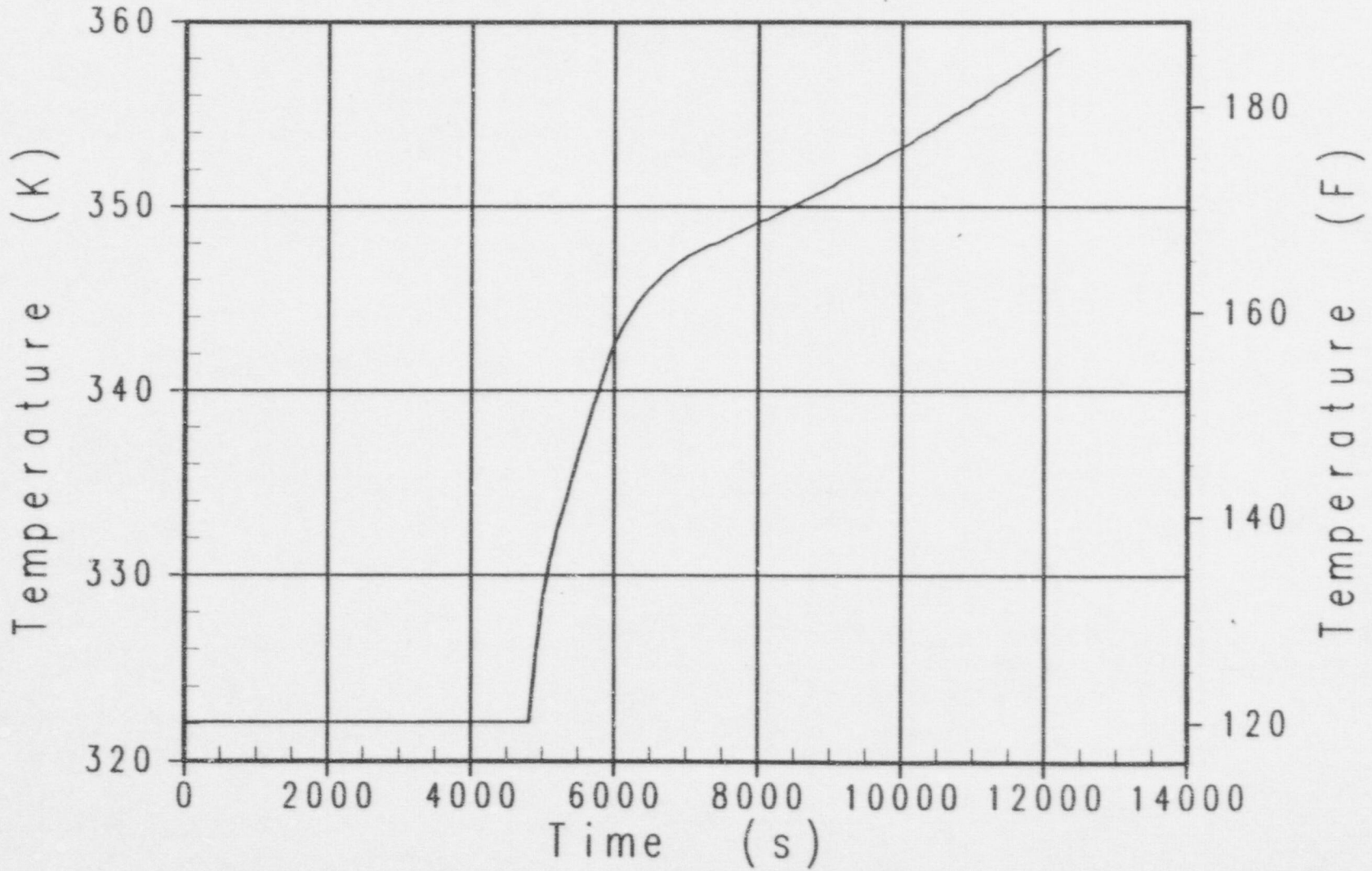

Case g4d2 AP600 Success Criteria MAAP4 Analysis
Accumulator and NRHR Injection Flowrate

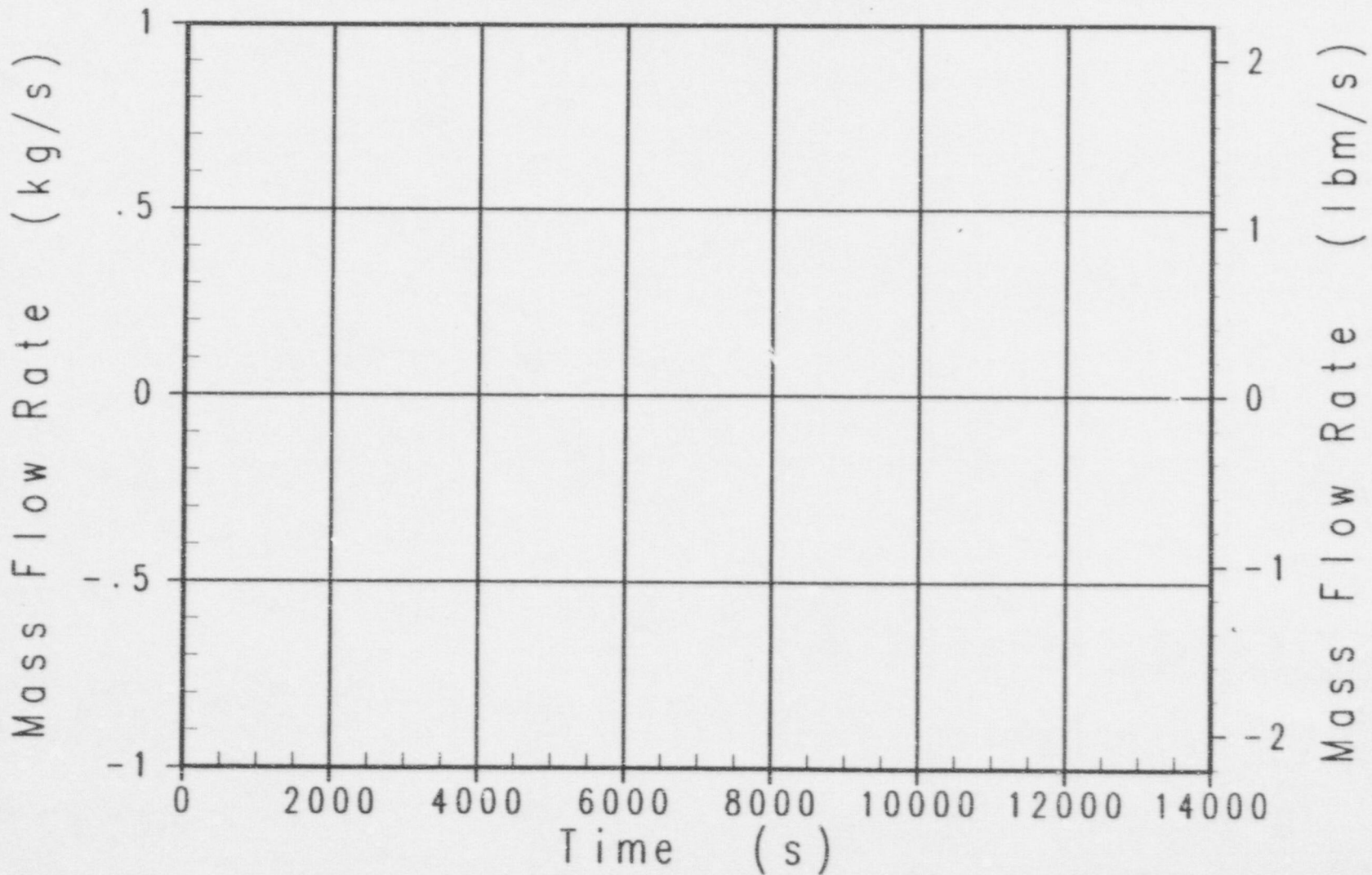

Case g4d2 AP600 Success Criteria MAAP4 Analysis
RCS Break Gas Flowrate

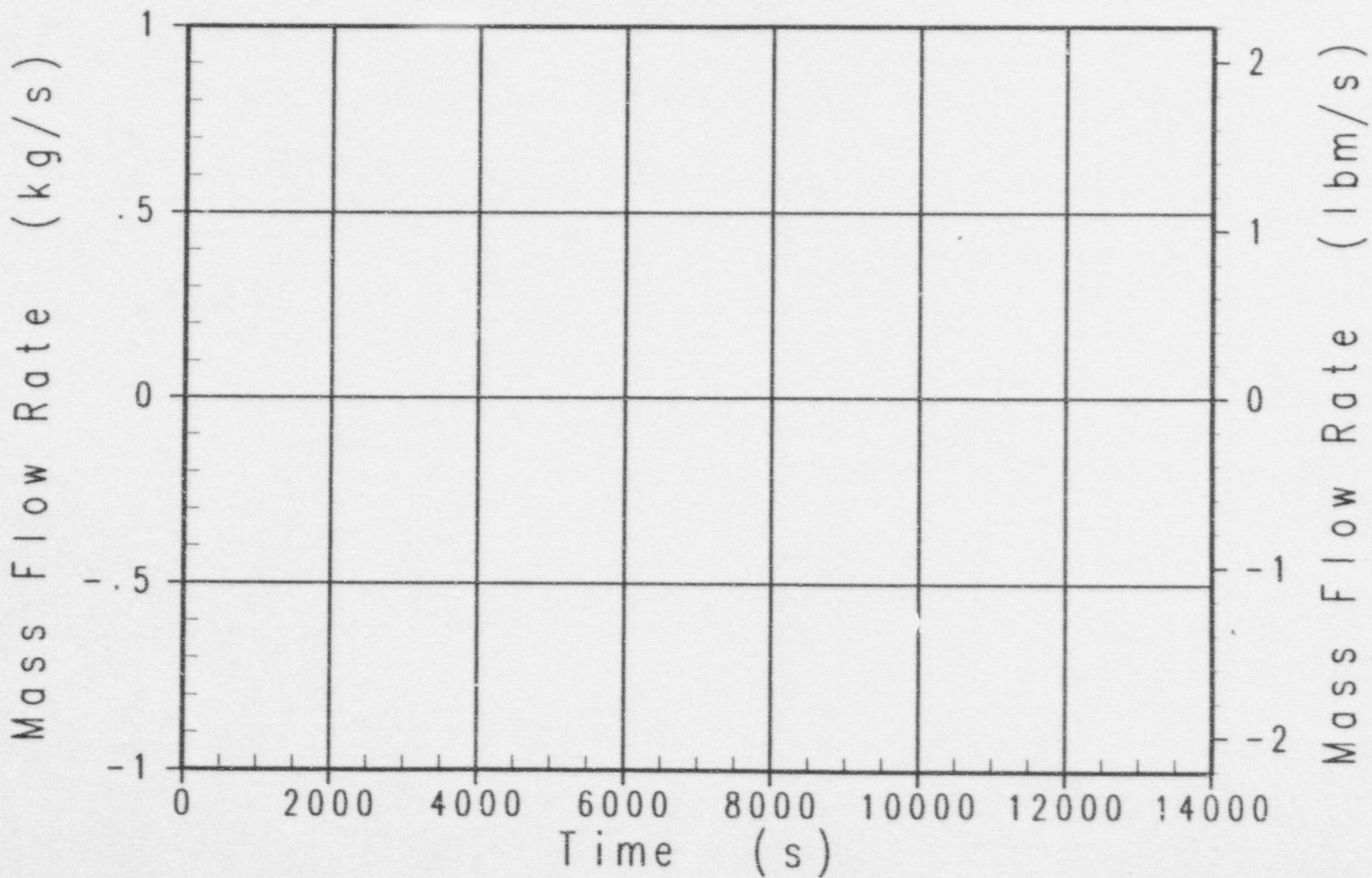

Case g4d2 AP600 Success Criteria MAAP4 Analysis
ADS Stage 4 Gas Flowrate

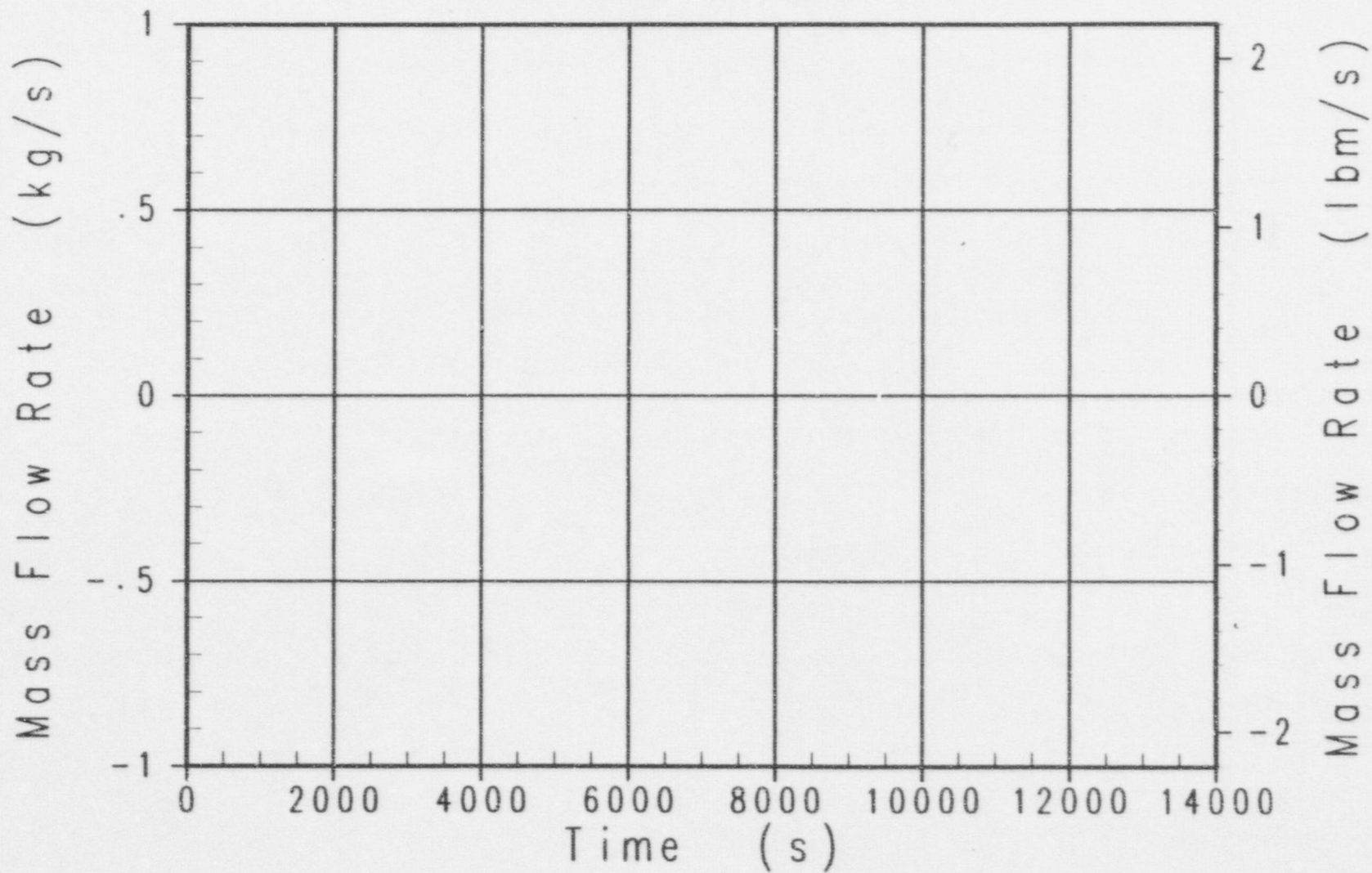

Case g4d2 AP600 Success Criteria MAA4 Analysis
Safety Valve and ADS Stages 1-3 Gas Flowrate

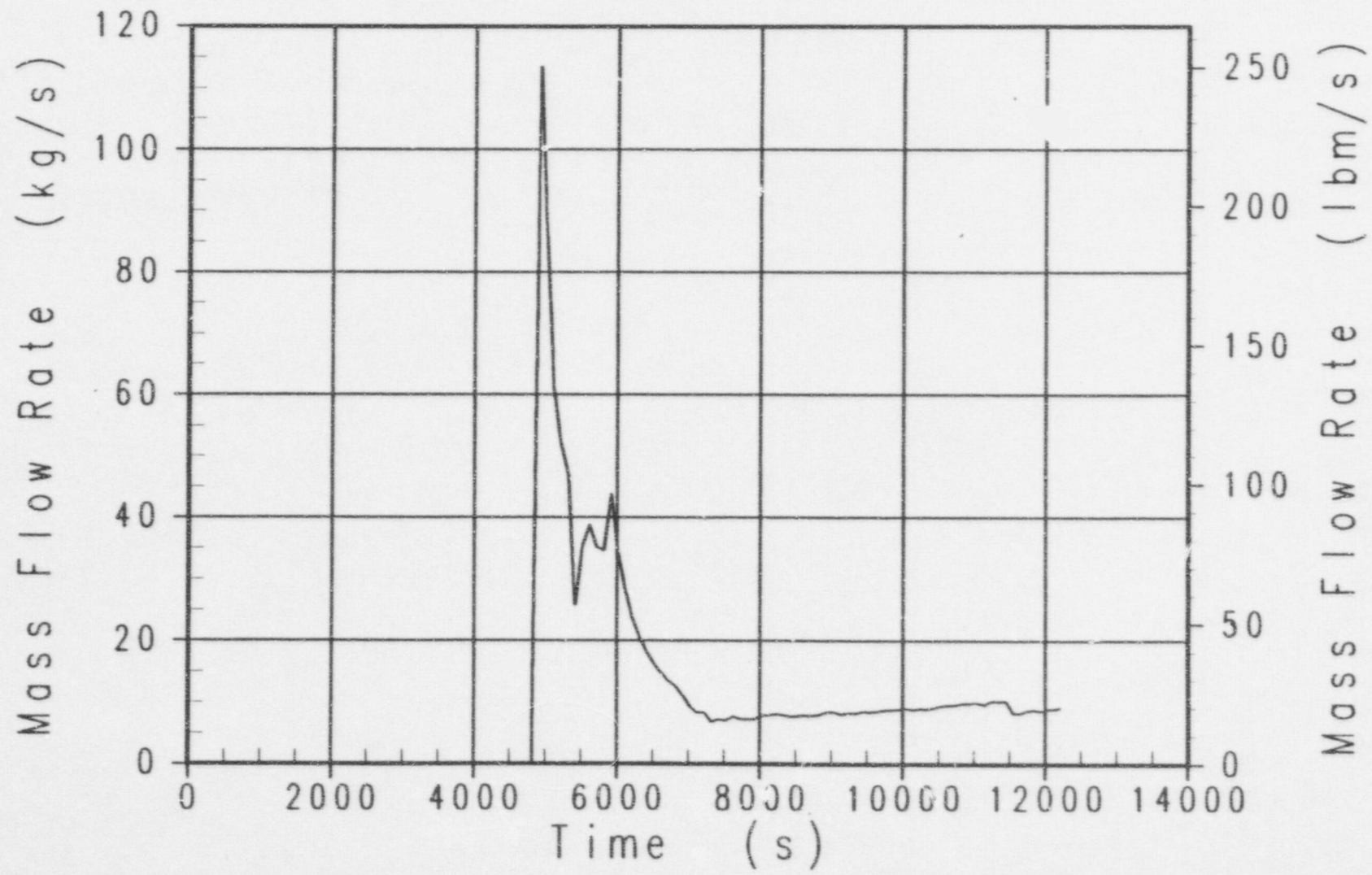

Case g4d2 AP600 Success Criteria MAAP4 Analysis
RCS Break Liquid Flowrate

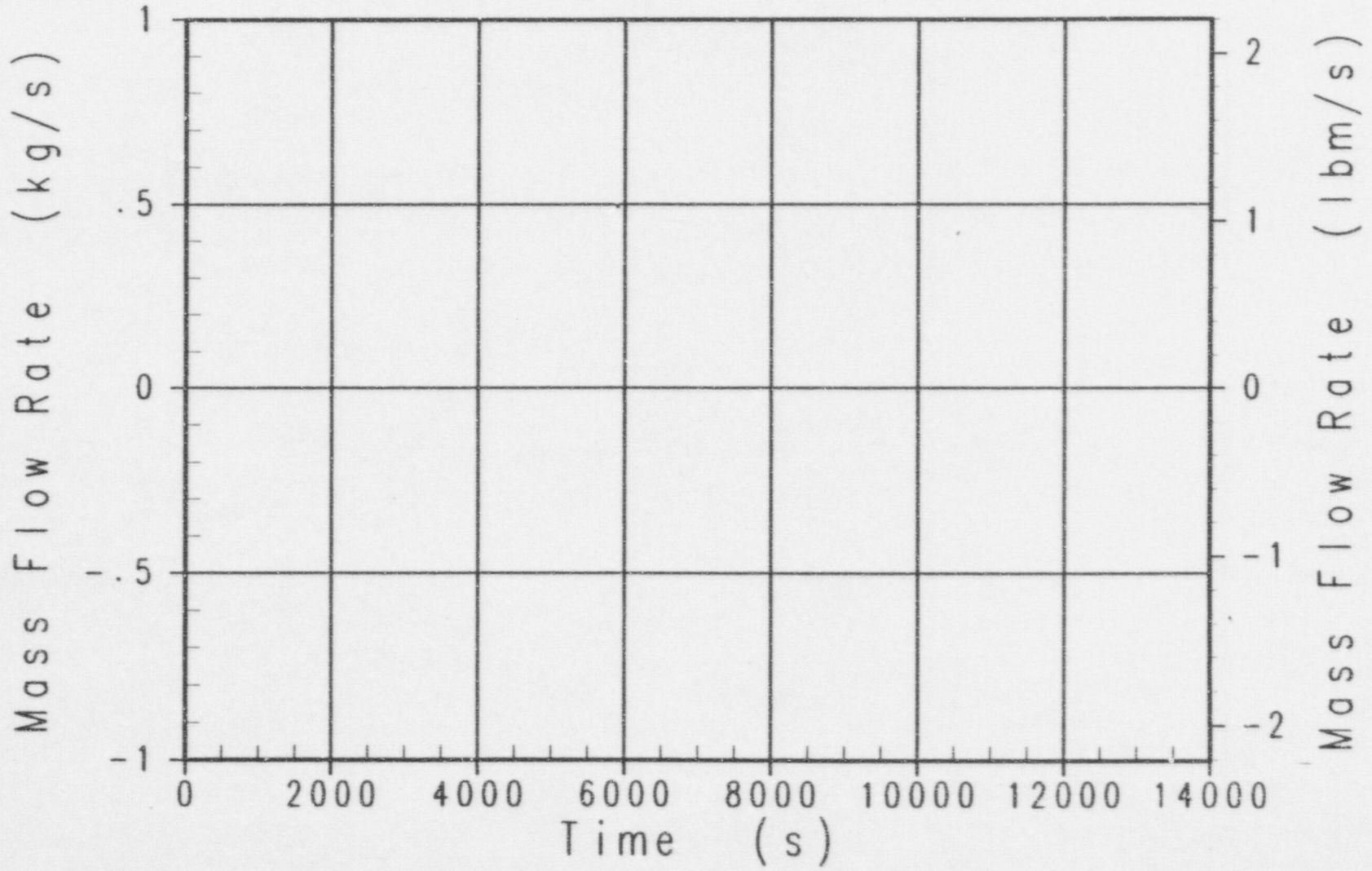

Case g4d2 AP600 Success Criteria MAAP4 Analysis
ADS Stage 4 Liquid Flowrate

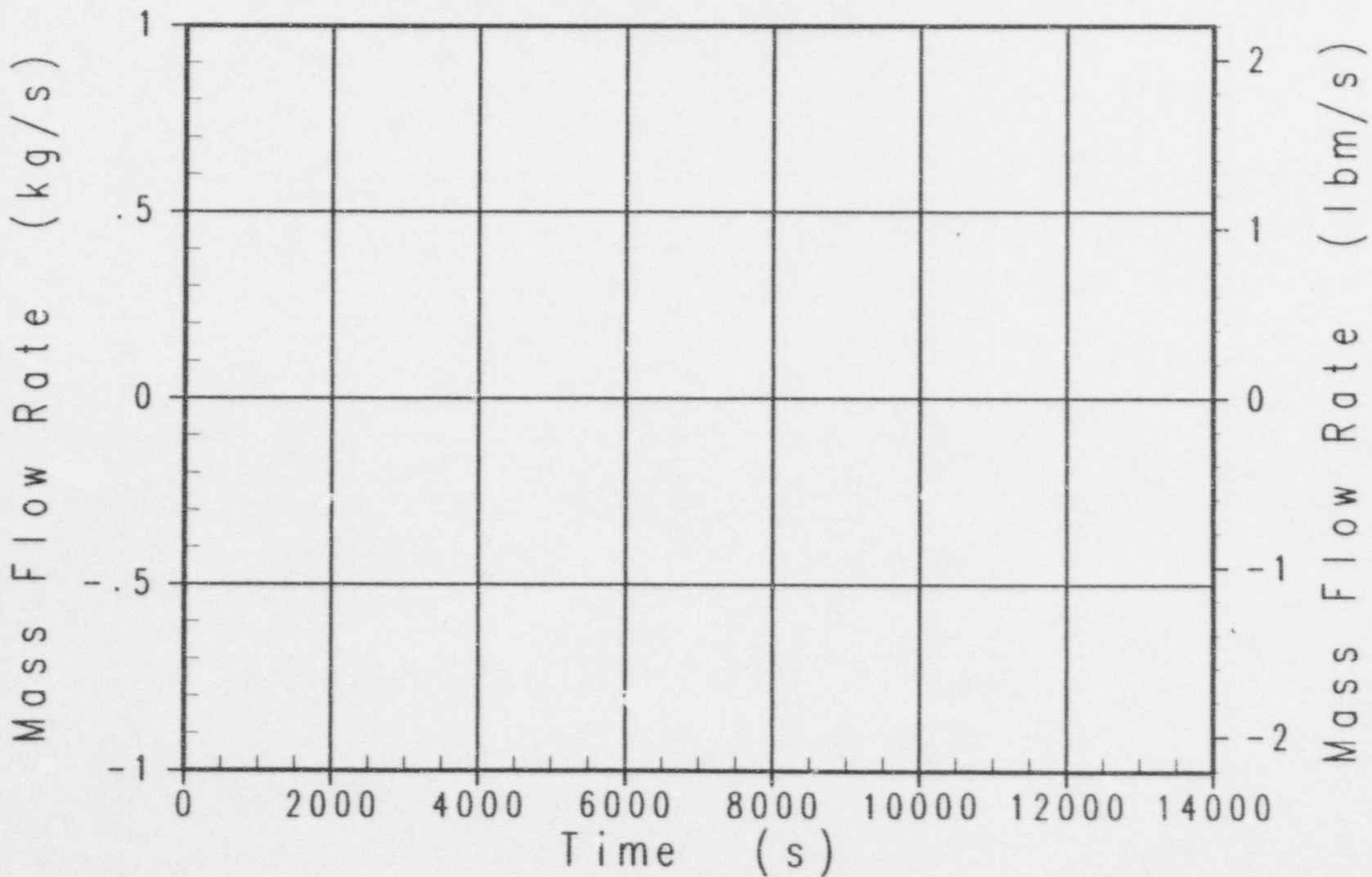

Case g4d2 AP600 Success Criteria MAAP4 Analysis
IRWST Injection Flowrate (neg. means into RCS)

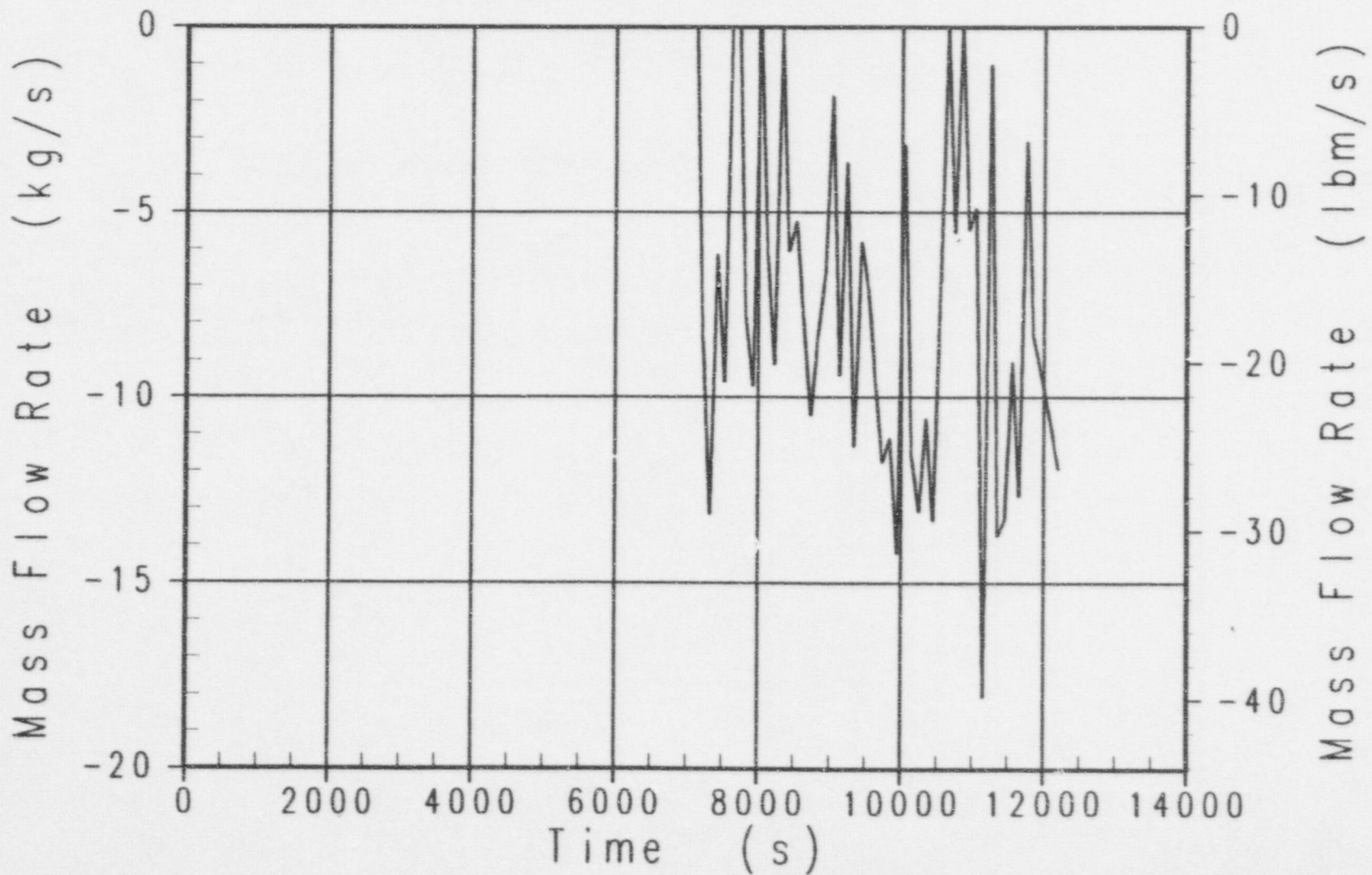

Case g4d2 AP600 Success Criteria MAAP4 Analysis
CMT-1 Injection Flowrate

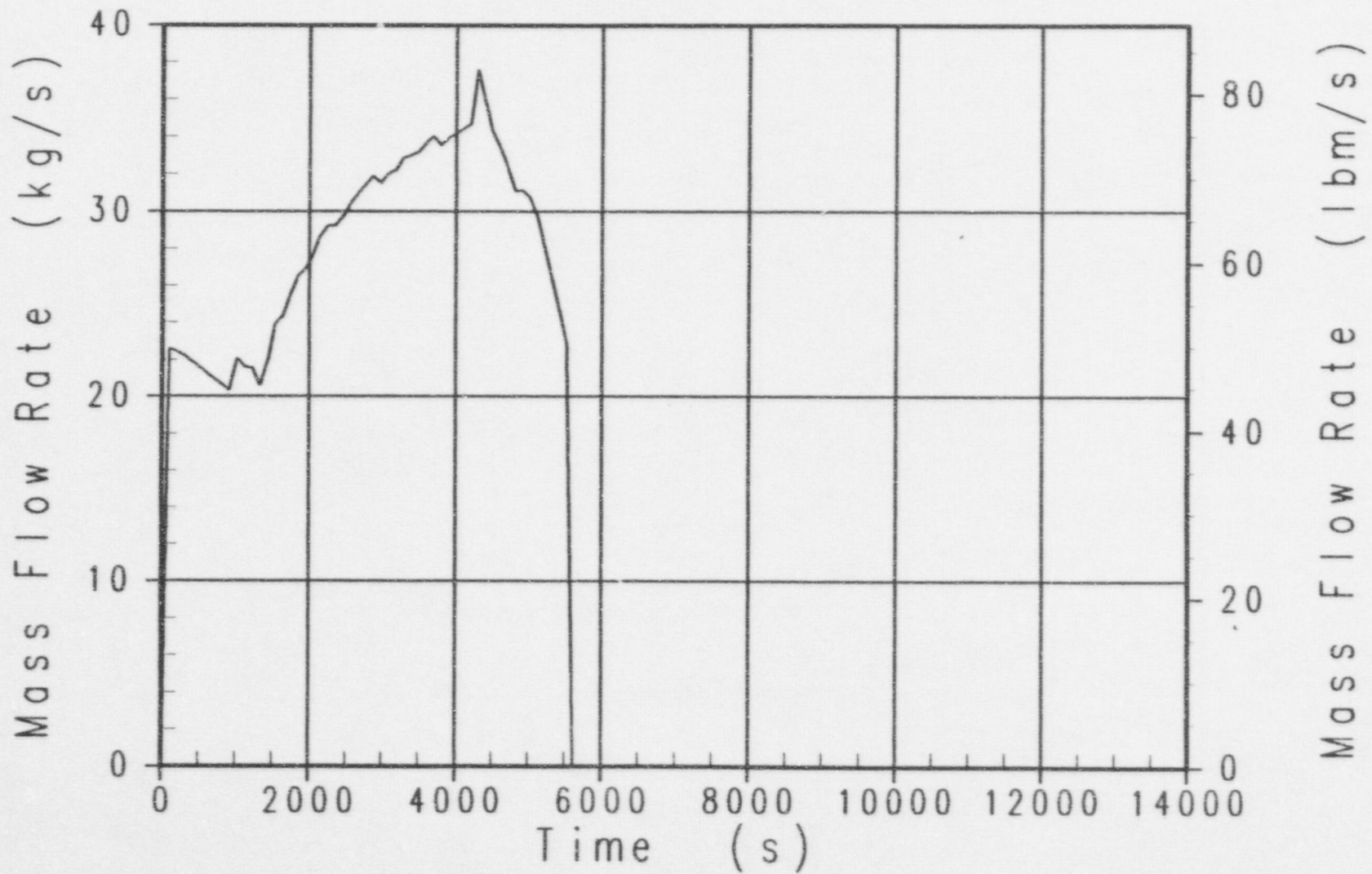

Case g4d2 AP600 Success Criteria MAAP4 Analysis
Safety Valve and ADS Stages 1-3 Liquid Flowrate

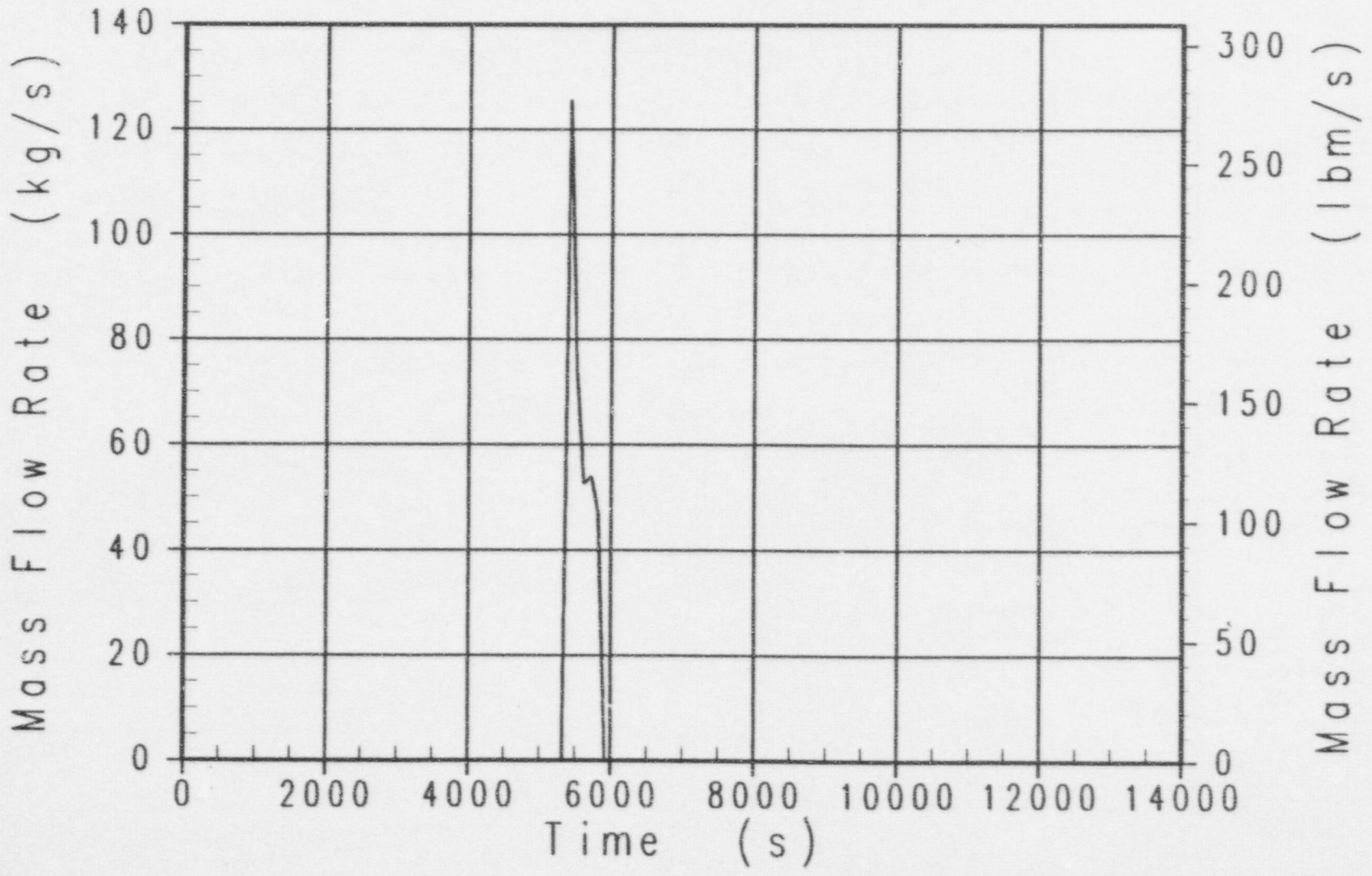

Case g4d2 AP600 Success Criteria MAAP4 Analysis
CMT-1 Water Level

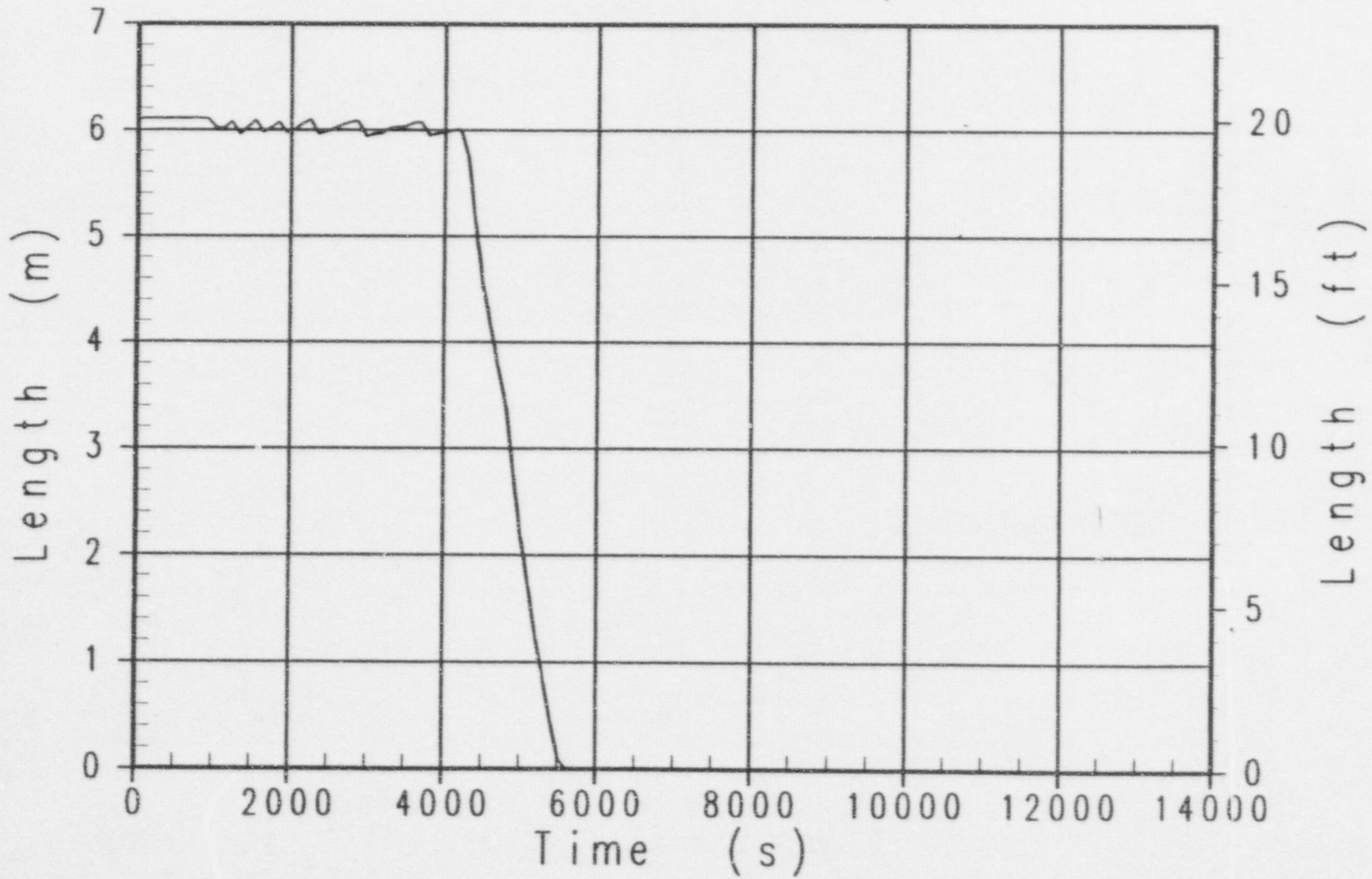

Case g4d2 AP600 Success Criteria MAA4 Analysis
Pressurizer Water Level (From Pzr Bottom)

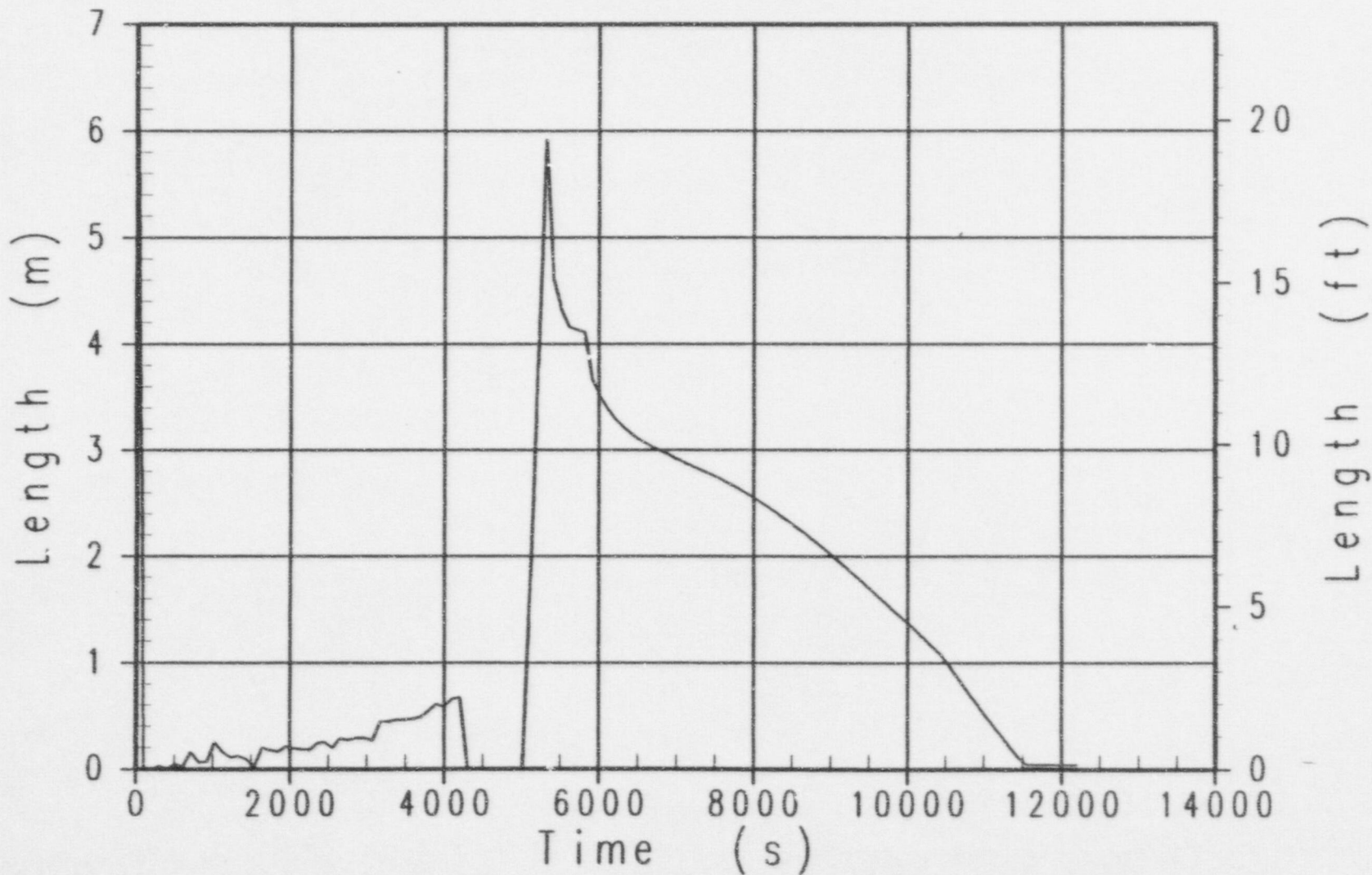



Westinghouse
Electric Corporation

Energy Systems

Box 355
Pittsburgh Pennsylvania 15230-0355

DCP/NRC1413
NSD-NRC-98-5757
Docket No.: 52-003

August 14, 1998

Document Control Desk
U. S. Nuclear Regulatory Commission
Washington, DC 20555

ATTENTION: T. R. Quay

SUBJECT: RESPONSE TO NRC LETTERS CONCERNING REQUEST FOR WITHHOLDING
INFORMATION

- Reference:
1. Letter, Sebrosky to McIntyre, "Request for withholding information from public disclosure for Westinghouse AP600 design letter of October 20, 1993," dated June 18, 1998.
 2. Letter, Sebrosky to McIntyre, "Request for withholding information from public disclosure for Westinghouse AP600 design letter of January 17, 1994," dated June 18, 1998.
 3. Letter, Sebrosky to McIntyre, "Request for withholding information from public disclosure for Westinghouse AP600 letters of September 20, 1993, January 21, 1994, and February 3, 1994," dated July 10, 1998.
 4. Letter, Sebrosky to McIntyre, "Request for withholding proprietary information for Westinghouse letters dated April 18, 1995," dated July 15, 1998.
 5. Letter, Huffman to McIntyre, "Request for withholding information from public disclosure of Westinghouse report on AP600 function based task analysis," dated July 17, 1998.

Dear Mr. Quay:

Reference 1 provided the NRC assessment of the Westinghouse claim that proprietary information was provided in a letter dated October 20, 1993, that contained the response to a staff request for additional information regarding the AP600 probabilistic risk assessment. The NRC assessment was that the material was similar to material that exists in the current (1998) nonproprietary version of the AP600 probabilistic risk assessment (PRA) report. In addition, the staff indicated the material was used by the staff in the development of the AP600 draft safety evaluation report and therefore should remain on the docket. At the time this request for additional information response was provided to the

3790a.wpf

~~9808200168~~ 411

Enclosure 2

August 14, 1998

NRC technical staff, the information was considered to be proprietary by Westinghouse since it contained information that had commercial value to Westinghouse. If this request for additional information response was indeed used by the staff in development of the AP600 draft final safety evaluation report in November 30, 1994, then at this time, almost five years later, this information is no longer considered to be proprietary by Westinghouse.

Reference 2 provided the NRC assessment of the Westinghouse claim that proprietary information was provided in a letter dated January 17, 1994, that contained the response to a staff request for additional information regarding the AP600 instrumentation and control system. The NRC assessment was that the material was similar to material that exists in the current (1998) nonproprietary version of the AP600 standard safety analysis report. In addition, the staff indicated the material was used by the staff in the development of the AP600 draft safety evaluation report and therefore should remain on the docket. At the time this request for additional information response was provided to the NRC technical staff, the information was considered to be proprietary by Westinghouse since it contained information that had commercial value to Westinghouse. If this request for additional information response was indeed used by the staff in development of the AP600 draft final safety evaluation report in November 30, 1994, then at this time, over four years later, this information is no longer considered to be proprietary by Westinghouse.

Reference 3 provided the NRC assessment of the Westinghouse claim that proprietary information was provided in a letter dated September 20, 1993, that contained information related to the AP600 PRA and WCAP-13795, which provided the PRA uncertainty analysis. The NRC assessment was that the material was similar to material that exists in the current (1998) nonproprietary version of the AP600 probabilistic risk assessment (PRA) report. In addition, the staff indicated the material was used by the staff in the development of the AP600 draft safety evaluation report and therefore should remain on the docket. At the time this information was provided to the NRC technical staff, it was considered to be proprietary by Westinghouse since it contained information that had commercial value to Westinghouse. If the information transmitted by the Westinghouse September 20, 1993, letter was indeed used by the staff in development of the AP600 draft final safety evaluation report in November 30, 1994, then at this time, almost five years later, this information is no longer considered to be proprietary by Westinghouse.

Reference 3 also provided the NRC assessment of the Westinghouse claim that proprietary information was provided in a letter dated January 21, 1994, that contained WCAP-13913, "Framework for AP600 Severe Accident Management Guidance" (SAMG). The NRC assessment was that the material was similar to material that exists in current (1998) nonproprietary AP600 documents (e.g., WCAP-13914, "Framework for AP600 Severe Accident Management Guidance"). In addition, the staff indicated the material was used by the staff in the development of the AP600 draft safety evaluation report and therefore should remain on the docket. At the time this Framework for SAMG was provided to the NRC technical staff, the information was considered to be proprietary by Westinghouse since it contained information that had commercial value to Westinghouse. At this time, over four years later, this information is no longer considered to be proprietary by Westinghouse.

1790a wjf

August 14, 1998

Reference 3 also provided the NRC assessment of the Westinghouse claim that proprietary information was provided in a letter dated February 3, 1994, that contained additional copies of WCAP-13913, "Framework for AP600 Severe Accident Management Guidance" (SAMG). The NRC assessment was that the material was similar to material that exists in current (1998) nonproprietary AP600 documents (e.g., WCAP-13914, "Framework for AP600 Severe Accident Management Guidance"). In addition, the staff indicated the material was used by the staff in the development of the AP600 draft safety evaluation report and therefore should remain on the docket. At the time this Framework for SAMG was provided to the NRC technical staff, the information was considered to be proprietary by Westinghouse since it contained information that had commercial value to Westinghouse. At this time, over four years later, this information is no longer considered to be proprietary by Westinghouse.

Reference 4 provided the NRC assessment of the Westinghouse claim that proprietary information was provided in a letter dated April 18, 1995, that contained information for a MAAP4/RELAP comparison for the AP600 in response to a staff request for additional information. The NRC assessment was that the Westinghouse cover letter indicated that Enclosure 2 is a non-proprietary version of Enclosure 3, however, the staff could not find any portion of the enclosures marked as proprietary. The staff assessment further states the conventional bracketed-superscript notation also appears to be missing. Finally, the NRC assessment states the staff could not determine which part of the material enclosed with the Westinghouse letter was Enclosure 1, 2, or 3. It should be noted that the Westinghouse April 18, 1995, cover letter states "Enclosures 2 (nonproprietary) and 3 (proprietary) provide the requested information." The letter does not indicate that enclosure 2 was a duplicate of enclosure 3 minus the proprietary information. A cover sheet was provided just prior to each of the enclosures to the Westinghouse letter. The enclosures contained the following: Enclosure 1 provided a copy of the NRC's two-page request for information for the MAAP-RELAP comparison. Enclosure 2 provided the requested information, and was titled "Requested Information for AP600 MAAP4/RELAP Comparison." Under section 4, Initial Conditions, of Enclosure 2 it states the initial conditions information (which was proprietary) is provided in Enclosure 3 of the subject Westinghouse letter. Finally, Enclosure 3 contained the list of initial conditions. The information provided in Enclosure 3 was labeled as Westinghouse Proprietary Class 2 at the top of the page, however, the specific proprietary information was not indicated by the bracketed-superscripted notation. In addition to the initial conditions, a mark-up of AP600 PRA Figure K-1 was provided in Enclosure 3. Again, the information was labeled as Westinghouse Proprietary Class 2 at the top of the page, however, the specific proprietary information was not indicated by the bracketed-superscripted notation. At the time the information provided in Enclosure 3 of the subject Westinghouse letter was provided to the NRC technical staff, the information was considered to be proprietary by Westinghouse since it contained information that had commercial value to Westinghouse. At this time, over three years later, this information is no longer considered to be proprietary by Westinghouse.

Reference 5 provided the NRC assessment of the Westinghouse claim that proprietary information was provided in a letter dated February 8, 1994, provided a copy of WCAP-13957, "AP600 Reactor Coolant System Mass Inventory: Function Based Risk Analysis." The NRC assessment was that the material was not "information that the staff customarily accepts as proprietary." In addition, the staff indicated the material was used by the staff in the development of the AP600 final safety evaluation report and therefore should remain on the docket. At the time this report was prepared, the

3790a.wpf

August 14, 1998

information was considered to be proprietary by Westinghouse since it contained information that had commercial value to Westinghouse and was of the type of information that was customarily held in confidence by Westinghouse. That the material was not information that the staff customarily accepts as proprietary is not relevant to making the proprietary determination. However, in an effort to expedite the issuance of the AP600 Final Safety Evaluation Report and Final Design Approval, Westinghouse agrees to no longer consider this information to be proprietary.

In a telephone call on July 8, 1998, the staff informed Westinghouse of a concern related to WCAP-13288 and WCAP-13289, which were associated with the AP600 check valve testing specification. The concern was that the proprietary report had no proprietary information identified and the nonproprietary report had been placed in the public document room. Westinghouse has reviewed these reports and, at this time, considers none of the information to be proprietary.

This response addresses the proprietary issues delineated in the references.

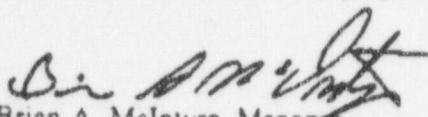
Brian A. McIntyre, Manager
Advanced Plant Safety and Licensing

jml

cc: J. W. Roe - NRC/NRR/DRPM
J. M. Sebrosky - NRC/NRR/DRPM
W. C. Huffman - NRC/NRR/DRPM
H. A. Sepp - Westinghouse