

A
9809290159 980922
PDR ADDCK 05200003
PDR

WESTINGHOUSE ELECTRIC CORPORATION

PRESENTATION

TO

UNITED STATES

NUCLEAR REGULATORY COMMISSION

WESTINGHOUSE ENERGY CENTER

FEBRUARY 24, 1993

Enclosure 1

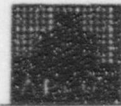

INTRODUCTION

H. J. BRUSCHI, GENERAL MANAGER
ADVANCED TECHNOLOGY BUSINESS AREA

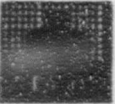

AP600 PROGRAM OVERVIEW

AND

SCHEDULE

B. A. McINTYRE, MANAGER

ADVANCED PLANT SAFETY & LICENSING

AP600 PROGRAM SCHEDULE

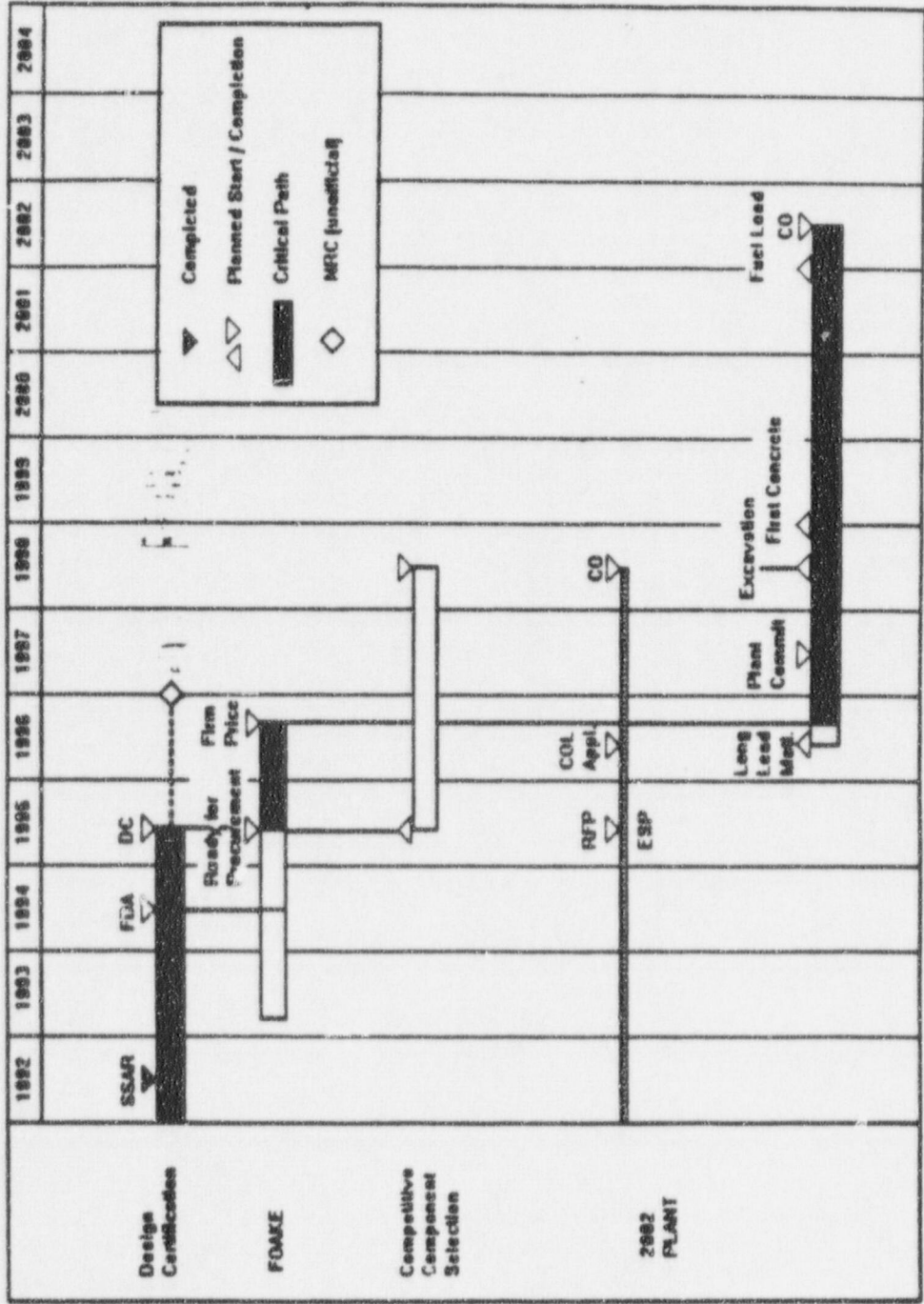
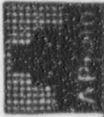

DESIGN CERTIFICATION ISSUES IMPACTING FOAKE



- o **ITAAC TESTING REQUIREMENTS**
 - o **SYSTEM AND EQUIPMENT DESIGN REQUIREMENTS**
 - o **PLANT LAYOUT**

- o **REGULATORY TREATMENT OF NONSAFETY SYSTEMS**
 - o **EQUIPMENT SPECIFICATIONS**
 - o **CONTROL ROOM DESIGN**
 - o **EMERGENCY RESPONSE GUIDELINES**

- o **SOURCE TERM**
 - o **EQUIPMENT QUALIFICATION**
 - o **PLANT LAYOUT**

AP600 TESTING MEETINGS



- o **AP600 Testing Program Review Meetings (December '92 - April '93):**
 - December 9, 1992 - OSU Tests Detailed Review**
 - December 10, 1992 - SPES-2 Tests Detailed Review**
 - February 25, 1993 - CMT Tests Detailed Review & Facility Visit**
 - March 9-10, 1993 - Test Program Review and Facility Visits**
 - March 23-24, 1993 - Containment Tests Review and Facility Visits**
 - April 20, 1993 - ADS Tests Review and Facility Visit**
 - April 22, 1993 - SPES-2 Tests Review and Facility Visit**

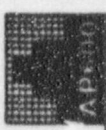

AP600 RAI SUMMARY

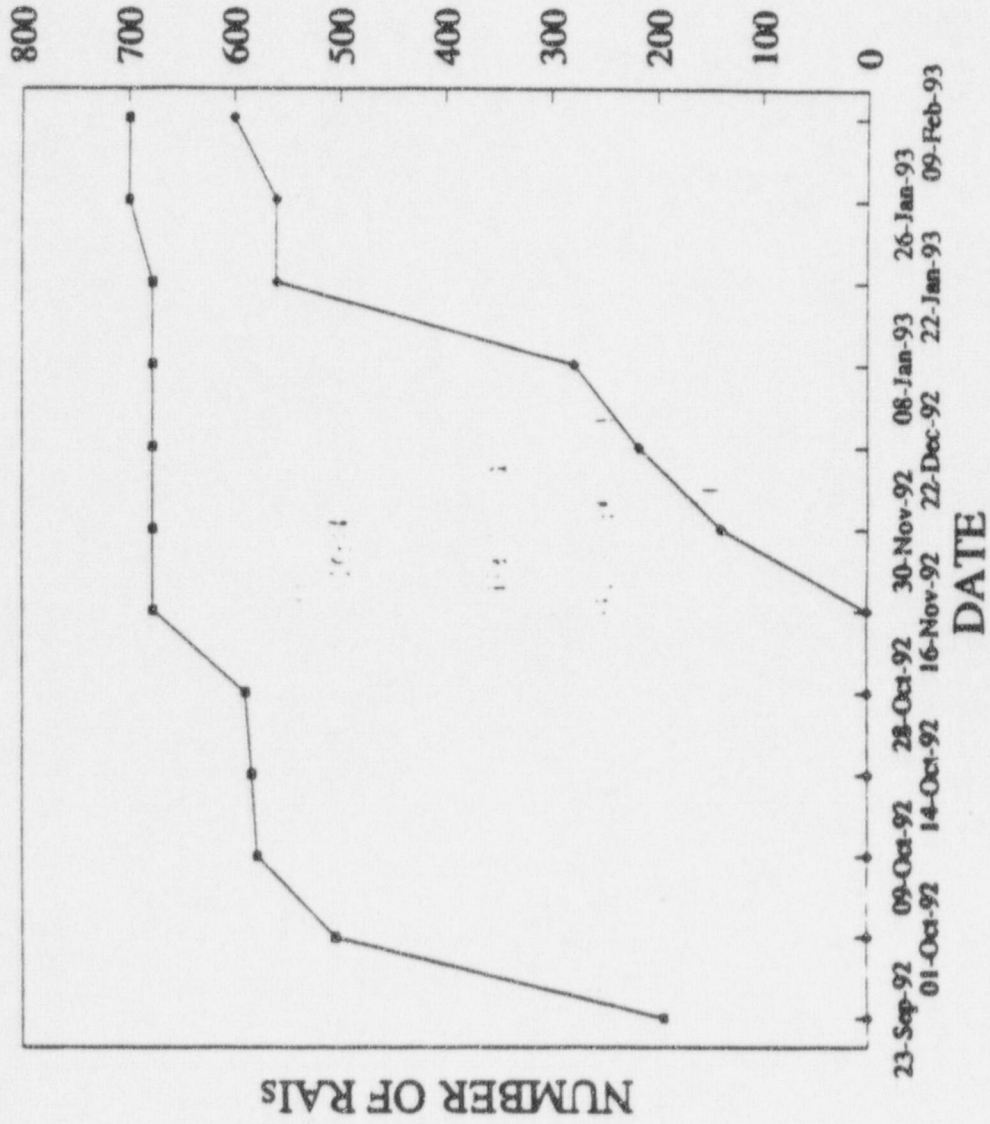

• RECEIVED - - - ANSWERED

AP600 REGULATORY TREATMENT OF NONSAFETY SYSTEMS



- o THE KEY AP600 LICENSING ISSUE
 - o PLANT DESIGN PHILOSOPHY
 - o ITAAC
 - o TECHNICAL SPECIFICATIONS
 - o RELIABILITY ASSURANCE PROGRAM
- o JANUARY 22 AGREEMENT IN PRINCIPLE IN LINE WITH WESTINGHOUSE APPROACH
- o WORKING CLOSELY WITH ALWR USC
 - o DEVIL IN THE DETAILS

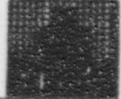

INTERNATIONAL PARTICIPANTS

**S. L. KEANEY, MANAGER
PROGRAM CONTROL AND
CONTRACT ADMINISTRATION**

AP600 INTERNATIONAL PARTICIPATION



<u>COUNTRY</u>	<u>AGENCY/ ORGANIZATION</u>	<u>SCOPE OF WORK</u>
Argentina*	CNEA - Comision National de Energia Atomica	TBD
Bulgaria*	NEK - Natsionalna Elektricheska Kompania	TBD
Croatia*	Ministry of Industry, Energy & Shipbuilding; Croatian Electricity Generating Board	TBD
Czechoslovakia	Czech Power Board	Nuclear Safety Analysis
Egypt*	NPPA - Nuclear Power Plants Authority	TBD

AP600 INTERNATIONAL PARTICIPATION



<u>COUNTRY</u>	<u>AGENCY/ ORGANIZATION</u>	<u>SCOPE OF WORK</u>
Finland*	IVO - Imatron Voima Oy	TBD
Indonesia	BATAN - Badan Tenaga Atom Nasional BPPT - Badan Pengkajian dan Penerapan Teknologi PLN - Perusahann Umum Listrik Negara	plant layout; structural analysis; BOP design; electrical design; testing support
Italy	SOPREN/ANSALDO - (W) NSSS systems licensee	system and component design; testing; core design; fluid systems design; PCCS design studies

AP600 INTERNATIONAL PARTICIPATION



<u>COUNTRY</u>	<u>AGENCY/ ORGANIZATION</u>	<u>SCOPE OF WORK</u>
Italy	ENEA - Comitato Nazionale per la Ricerca e per lo Sviluppo Dell 'Energia Nucleare e delle Energie Alternatice	ADS testing; full height, full pressure integral systems tests; safety system analysis
	ENEA-CRE (research branch of ENEA); part of four party Technical Cooperation Agreement	ADS testing; ADS valve testing
	ENEA-DISP (regulatory branch) subcontractor to SOPREN/ANSALDO	fluid systems design; in-service inspection requirements; containment analysis
	ENEL - Ente Nazionale per L'energia Electrica	probabilistic safety studies; LOCA; severe accident analysis

AP600 INTERNATIONAL PARTICIPATION

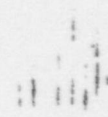

<u>COUNTRY</u>	<u>AGENCY/ ORGANIZATION</u>	<u>SCOPE OF WORK</u>
Italy	FIAT-CIEI - Componenti e Impianti per L'Energia e L'Industria; subcontractor to SOPREN/ANSALDO and direct participant	fluid systems; NSSS component design (RV internals, integrated head package, fuel handling system)
	Belleli - engineering company; subcontractor to SOPREN/ANSALDO	design of passive residual heat removal heat exchanger
	SIET - Societe Informazioni Esperienze Termoidrauliche; research company (shareholders = ENEL and ENEA)	full height full pressure integral systems tests

AP600 INTERNATIONAL PARTICIPATION

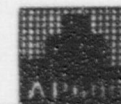

<u>COUNTRY</u>	<u>AGENCY/ ORGANIZATION</u>	<u>SCOPE OF WORK</u>
Japan	JAPC - Japan Atomic Power Company	I&C design, BOP
Latvia*	Latvia Academy of Sciences	TBD
Lithuania*	Lithuanian Ministry of Energy	TBD
Poland	IEA - Institute of Atomic Energy	safety analysis; PRA; equipment design; BOP design
Spain	ENDESA - Empresa Nacional de Electricidad SA (through EPRI)	fluid systems; NSSS design
	ENUSA	nuclear safety analysis

AP600 INTERNATIONAL PARTICIPATION



<u>COUNTRY</u>	<u>AGENCY/ ORGANIZATION</u>	<u>SCOPE OF WORK</u>
Spain	INITEC - Empresa Nacional de Ingenieria y Tecnologia	PSARV module analysis; structural steel framing; floor slabs, NI basemat
	UNESA - Unidad Electrica SA	I&C; Reactor Vessel; Pressurizer, NI module design
	UTE - Initec/Agrupacion JV	pipng system analysis; piping modules design; electrical equipment specifications; plant design and layout inside containment
Thailand*	EGAT - Electricity Generating Authority of Thailand	TBD

* Currently under negotiation

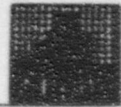

PROBABILISTIC RISK ASSESSMENT

C. L. HAAG, SENIOR ENGINEER
RISK MANAGEMENT AND
OPERATIONS IMPROVEMENT

AP600 PRA

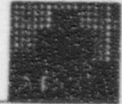

AGENDA

- Passive System Reliability
- Initiating Event Evaluation
- Sensitivity Studies of Nonsafety Systems
- PRA Insights and System Importance

AP600 PRA

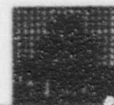

11/11

PASSIVE SYSTEM RELIABILITY

AP600 PRA

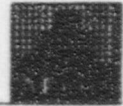

PASSIVE SYSTEM MODELING

- **Input to calculate system reliability**
 - Detailed design information
 - System success criteria for each initiating event
 - Initial system configuration
 - Required support systems

- **Develop and quantify system fault trees**

- **Example illustrates calculation of Passive RHR reliability**

AP600 PRA

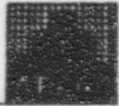

EXAMPLE PRHR SYSTEM INPUT

- **Detailed Design Information**
 - System Specification Document
 - System Functions
 - System Description
 - Maintenance and Testing
 - Equipment Description
 - Instrumentation and Controls
 - Electrical Power
 - System Interfaces
 - Piping and Instrumentation Diagrams
 - Major equipment drawings
 - Pipe routing drawings
 - Plant arrangement drawings
 - Technical Specifications

AP600 PRA

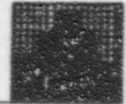

EXAMPLE PRHR SYSTEM INPUT

- **Initiator**
 - Transient event
- **Success Criteria**
 - PRHR to remove decay heat from RCS
 - 1/2 AOVs on HX outlet line must open
- **Initial System Condition**
 - Both AOVs normally closed
 - AOVs fail open on loss of air or power
- **Mission Time**
 - 24 hours
- **Support Systems**
 - Actuated by: Protection and Monitoring System
Diverse Actuation System

AP600 PRA

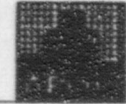

FAILURE CONSIDERATIONS IN A PRHR FAULT TREE

- **Equipment Failures**
 - AOVs fail to open
 - IRWST ruptures
 - Plugging of flow venturi
 - Instrumentation and control equipment

- **Test/Maintenance Consideration**
 - AOVs tested every 3 months
 - System available during test
 - Component maintenance unavailability

AP600 PRA

FAILURE CONSIDERATIONS IN A PRHR FAULT TREE

- **Operator Actions**
 - When automatic actuation fails:
 - Operator fails to recognize need for decay heat removal
 - Operator fails to actuate PRHR AOVs

- **Common Cause Failures**
 - Failure of AOVs
 - Instrumentation and Control

AP600 PRA

OTHER FAILURE CONSIDERATIONS OF PRHR

- **Gas Binding in PRHR HX**
 - Alarmed in control room
 - Venting performed after maintenance/inspection
 - H₂ in RCS is saturated at 30 psig so it can not come out of solution
 - PRHR HX not required at RCS pressure where accumulator could empty (<100 psig)

- **Heat Transfer Performance**
 - Performed AP600-specific heat transfer test (full pressure/temp)
 - Verify with ITAAC (full pressure/temp)
 - Test HX every refueling (intermediate pressure/temp)

- **Appropriately not modeled in fault tree**

AP600 PRA

SYSTEM RELIABILITY DATA

- **Primary Source**
 - ALWR Utility Requirements Document (Volume III)

- **Secondary Sources**
 - NUREG/CR-2728 (IREP)
 - NUREG/CR-2815 (NREP)
 - NUREG/CR-4550
 - WASH-1400
 - IEEE Std 500
 - Westinghouse

AP600 PRA

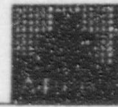

PRHR SYSTEM RELIABILITY

- **Calculated PRHR system reliability**
 - Unavailability calculated to be $7.7E-5$
- **Equipment in PRHR system similar in duty and design to operating plants which justifies the use of historical equipment reliabilities.**
 - Single AOV fail to open $1.1E-3$
 - Both AOVs fail to open $1.2E-6$
 - Common cause failure of AOVs $6.2E-5$

AP600 PRA

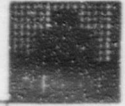

INITIATING EVENT EVALUATION

AP600 PRA

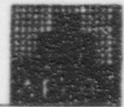

INITIATING EVENT EVALUATION

- **Initiating event frequencies for AP600 are based on historical data and AP600-specific analysis**
- **Transients**
 - Detailed review of operating experience at 51 PWRs from 1984 to mid-1989 (INPO data). Adjusted data as appropriate to account for reduced number of loops.
- **Loss of Offsite Power**
 - Frequency based on ALWR URD data
- **Loss of Coolant Accidents**
 - LOCAs are AP600-specific pipe break analysis
- **Support System Initiators**
 - Based on AP600-specific fault tree analysis. Includes loss of CCW, SW, and Compressed Air

AP500 PRA

INITIATING EVENT FREQUENCY DEPENDENCY VS NSS/DID SYSTEMS

<u>Initiating Event</u>	<u>NSS System</u>	<u>DID System</u>
Transients:		
Turbine trip	x	
Loss of feedwater flow	x	
Secondary to primary side power mismatch	x	
Core power excursion	x	
Spurious S-signal	x	
Loss of CCW		x
Loss of SW		x
Loss of compressed air	x	
Main steamline break downstream of MSIV		
Main steamline break upstream of MSIV		
Main steam line safety valve stuck open		
LOOP	x	
LOCAs:		
Large LOCA		
Medium LOCA		
CMT line break		
SI line break		
Small LOCA		
Very small LOCA		x
PRHR tube rupture		
SGTR		
Vessel rupture		
AIWS	x	

AP600 PRA

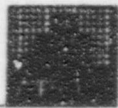

EXAMPLE LOCA INITIATING EVENT FREQUENCY CALCULATION

- **Very Small LOCA**

- Ruptures in pipes less than 3/4 inch diameter
 - Pressurizer level instrumentation lines
 - Miscellaneous primary system lines < 3/4 inch
- Frequency calculation equation
 - Pipe rupture failure rate x number of pipe sections
- Initiating event frequency is 5.5E-04 /yr

AP600 PRA

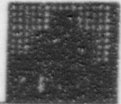

LEAKAGE EVENTS

- **NRC/Brookhaven reported 39 leakage events (1 gpm - 100 gpm)**
- **Westinghouse reviewed events and determined 5 at power events apply to AP600**

<u>NRC #</u>	<u>LER #</u>	<u>Description</u>	<u>Leak (gpm)</u>
17	323-89006	Pzr SV seal	10.0
20	339-91011	RHR valve packing	10.0
18	323-91004		1.9
11	302-90001	PORV block valve packing	1.3
28	369-90025	PORV packing	1.0

- **For leaks < 1 gpm, below Tech Spec limit, continue plant operation**
- **For leaks 1 - 100 gpm, proceed with orderly shutdown**

LEAKAGE EVENTS

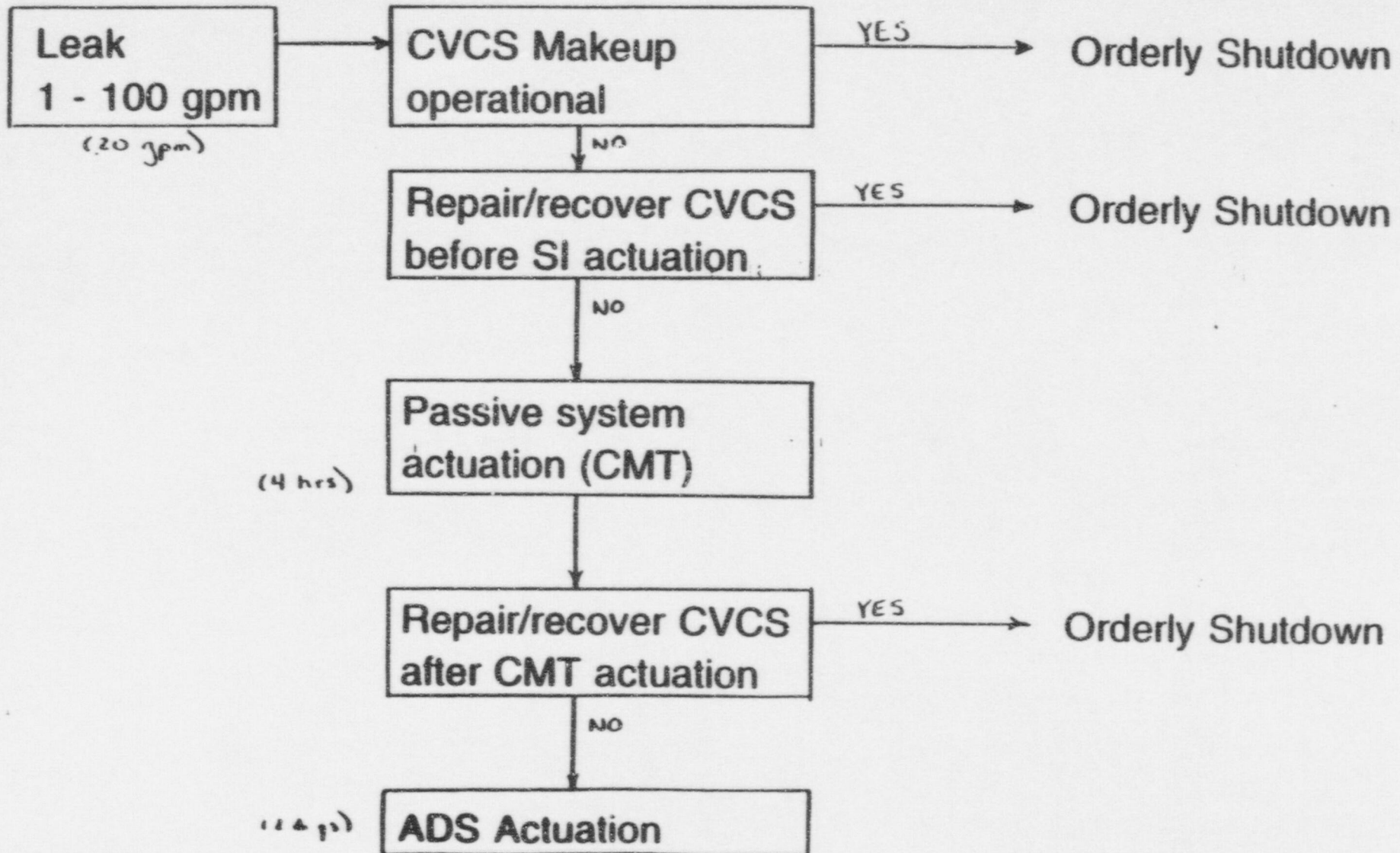

AP600 PRA

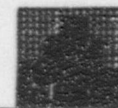

SENSITIVITY STUDIES OF NONSAFETY SYSTEMS

1000
1000

AP600 PRA

AP600 NON-SAFETY SYSTEM SENSITIVITY CASE

Estimated Core Damage Frequency

	<u>At Power</u>	<u>Shutdown</u>	<u>Total</u>
Base Case	3.3E-7 /yr	8.9E-8 /yr	4.2E-7 /yr
Sensitivity Case	2.6E-6 /yr	5.4E-7 /yr	3.1E-6 /yr
NRC Goal			1.0E-4 /yr

Note: Sensitivity case removes credit for CVS, SFW, RNS, offsite power and DGs following an initiating event

AP600 PRA

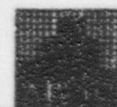

AP600 NON-SAFETY SYSTEM SENSITIVITY CASE

	Estimated Release Frequency		
	<u>At Power</u>	<u>Shutdown</u>	<u>Total</u>
Base Case	2E-8 /yr	1E-9 /yr	2E-8 /yr
Sensitivity Case	2E-7 /yr	7E-8 /yr	3E-7 /yr
NRC Goal			1E-6 /yr

Note: Sensitivity case removes credit for CVS, SFW, RNS, offsite power and DGs following an initiating event

AP600 PRA

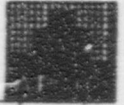

PRA INSIGHTS AND SYSTEM IMPORTANCE

AP600 PRA



PRA INSIGHTS VERSUS IMPORTANT ANALYSIS

- **PRA Insights**
 - Identified insights in AP600 PRA report (Chapter 17)
 - Insights are changes made to the design, operation, or PRA success criteria
 - Insights are not intended to be a listing of the risk important features of the plant

- **Importance Analysis**
 - Used in response to some RAIs

AP600 PRA

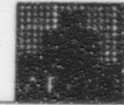

PRA SYSTEM IMPORTANCE

RAI 720.13 - Requested system level importance

Results of RAI 720.13:

- Gravity Injection
 - Largest increase in core damage and release frequencies
 - System required for SI line break and large LOCAs

- Passive RHR
 - Second largest increase in core damage and release frequencies

- Accumulators, CMTs, ADS Stages 1-3, ADS Stage 4
 - Small increase in frequencies due to system redundancy

AP600 PRA

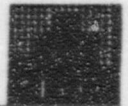

PRA SYSTEM IMPORTANCE

- Startup Feedwater, Normal RHR, and DGs
 - Negligible impact on core damage and release frequencies

- CVCS
 - Relatively minor importance on core damage
 - Small increase in release frequency due to LOCA events with a large, pre-existing opening in containment

AP600 PRA

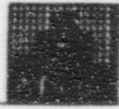

AP600 PRA INSIGHTS

- **Success criteria changes**
 - Accumulator or CMT for small or medium LOCAs
 - One accumulator for large LOCA
 - Multiple ADS valve failures

- **Operation changes**
 - Start NRHR after any ADS
 - Require passive core cooling features during shutdowns
 - IST test intervals (ADS valves)

- **Design changes**
 - NRHR valves made remote
 - 4th stage ADS valves diverse
 - Expanded diverse I&C capabilities
 - Added redundant IRWST injection check valves
 - Added redundant / diverse IRWST recirc valves
 - Made CMT check valves normally open



REGULATORY TREATMENT OF NONSAFETY SYSTEMS

**T. L. SCHULZ, FELLOW ENGINEER
SYSTEMS AND EQUIPMENT ENGINEERING**

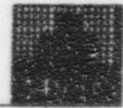

REGULATORY TREATMENT OF NONSAFETY SYSTEMS

- **Passive Systems Defense-In-Depth Capabilities**
- **Passive Systems Capabilities During Shutdowns**
- **Passive Systems Long Term Capabilities**
(Hurricane Andrew / post 72 hours)
- **Nonsafety DID System Safety Isolation Functions**
- **Reliability of Important Systems / Components**

AP600

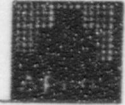

Passive Safety System Defense-In-Depth Capabilities

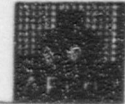

PASSIVE SYSTEM DID CAPABILITIES

- **Passive Safety Systems Provide Defense-In-Depth Capabilities**
 - Some provided in original design; others provided in design changes incorporated to improve PRA
 - More probable events have greater protection
 - Supported by best estimate analysis

AP600 LEVELS OF DEFENSE

FUNCTION	CURRENT PWR	AP600
REACTOR SHUTDOWN	<ul style="list-style-type: none"> - CONTROL RODS (BREAKERS) - RIDEOUT (NEG MTC, AMSAC, AFWS, CVCS) 	<ul style="list-style-type: none"> - CONTROL RODS (BREAKERS) - CONTROL RODS (MG SETS) - RIDEOUT (MORE NEG MTC, DAS, PRHRS / SFWS, CMT / CVCS)
RCS OVERPRESSURE PROTECTION	<ul style="list-style-type: none"> - PZR PORV - HI PRES TRIP - PZR SAFETY VALVES 	<ul style="list-style-type: none"> - LARGER PZR - HI PRES TRIP - PZR SAFETY VALVES
RCS HEAT REMOVAL	<ul style="list-style-type: none"> - MAIN FEEDWATER SYS - AUX FEEDWATER SYS - MANUAL FEED/BLEED (PZR PORV, HHSI) 	<ul style="list-style-type: none"> - MAIN FEEDWATER SYS - STARTUP FEEDWATER SYS - PRHR HX - AUTO FEED/BLEED (CMT / IRWST, ADS) - MANUAL FEED/BLEED (ACCUM / NRHRS, ADS)
HIGH PRESSURE INJECTION	<ul style="list-style-type: none"> - CVCS PUMPS - HHSI PUMPS 	<ul style="list-style-type: none"> - CVCS PUMPS - CMT - ACCUM / IRWST (ADS) - ACCUM / NRHRS (ADS)
LOW PRESSURE INJECTION	<ul style="list-style-type: none"> - ACCUM - LHSI PUMPS 	<ul style="list-style-type: none"> - ACCUM - IRWST (ADS) - NRHRS PUMPS
LONG TERM RECIRC	<ul style="list-style-type: none"> - LHSI PUMPS FEEDING HHSI PUMPS 	<ul style="list-style-type: none"> - CONTAINMENT SUMP (ADS) - NRHRS PUMPS
CONTAINMENT HEAT REMOVAL	<ul style="list-style-type: none"> - FAN COOLERS - CONT SPRAY PUMPS / HX 	<ul style="list-style-type: none"> - FAN COOLERS - EXTERNAL AIR + WATER DRAIN - EXTERNAL WATER FIRE SYSTEM - EXTERNAL AIR ONLY COOLING

AP600 DECAY HEAT REMOVAL

- **Startup Feedwater System**
 - Non-safety feedwater for normal shutdowns and transients
 - Two motor driven pumps feed all SGs
 - Water supplied from deaerating heater or CST
 - Automatic start and flow control
 - Automatic load on NNS diesels

- **Passive RHR Heat Exchanger**
 - Safety cooling for events where SFW is unavailable and during non-LOCA accidents
 - Two heat exchangers connected directly to RCS
 - Forced flow with RCP; natural circ without RCP
 - Automatic actuation; two fail-open valves
 - PRHR HX located in IRWST, provides heat sink
 - IRWST remains subcooled for 2 - 3 hours
 - Passive containment cooling provides ultimate heat sink

- **RCS Feed and Bleed**
 - Provides backup to SFW and to PRHR HX for PRA multiple failure events
 - Feed from CMT/Accum/IRWST, bleed from ADS
 - Automatic actuation of CMT on high RCS temp with low SG level

AP600 - MAIN & STARTUP FEEDWATER SYSTEMS

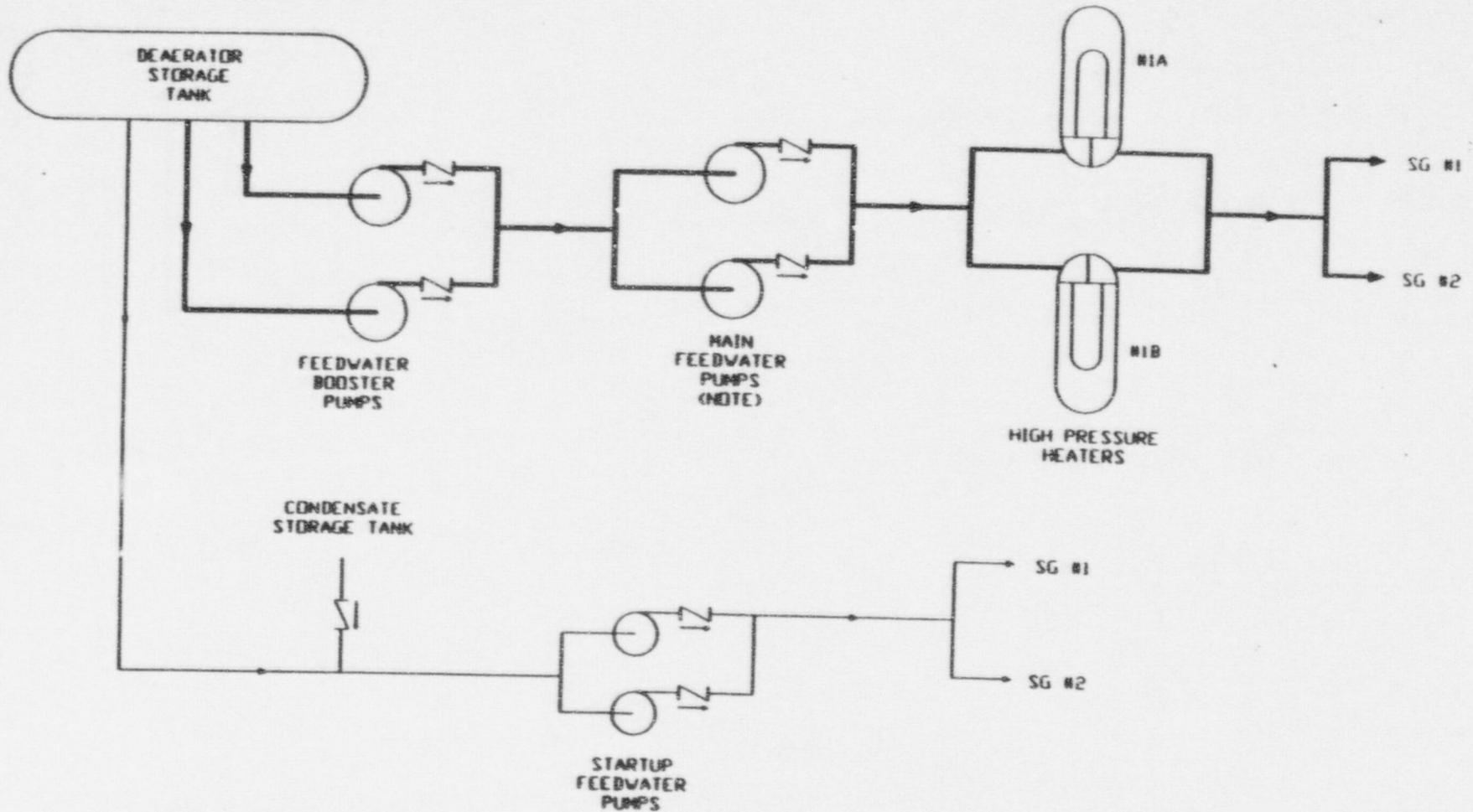

AP600 - PASSIVE SAFETY INJECTION

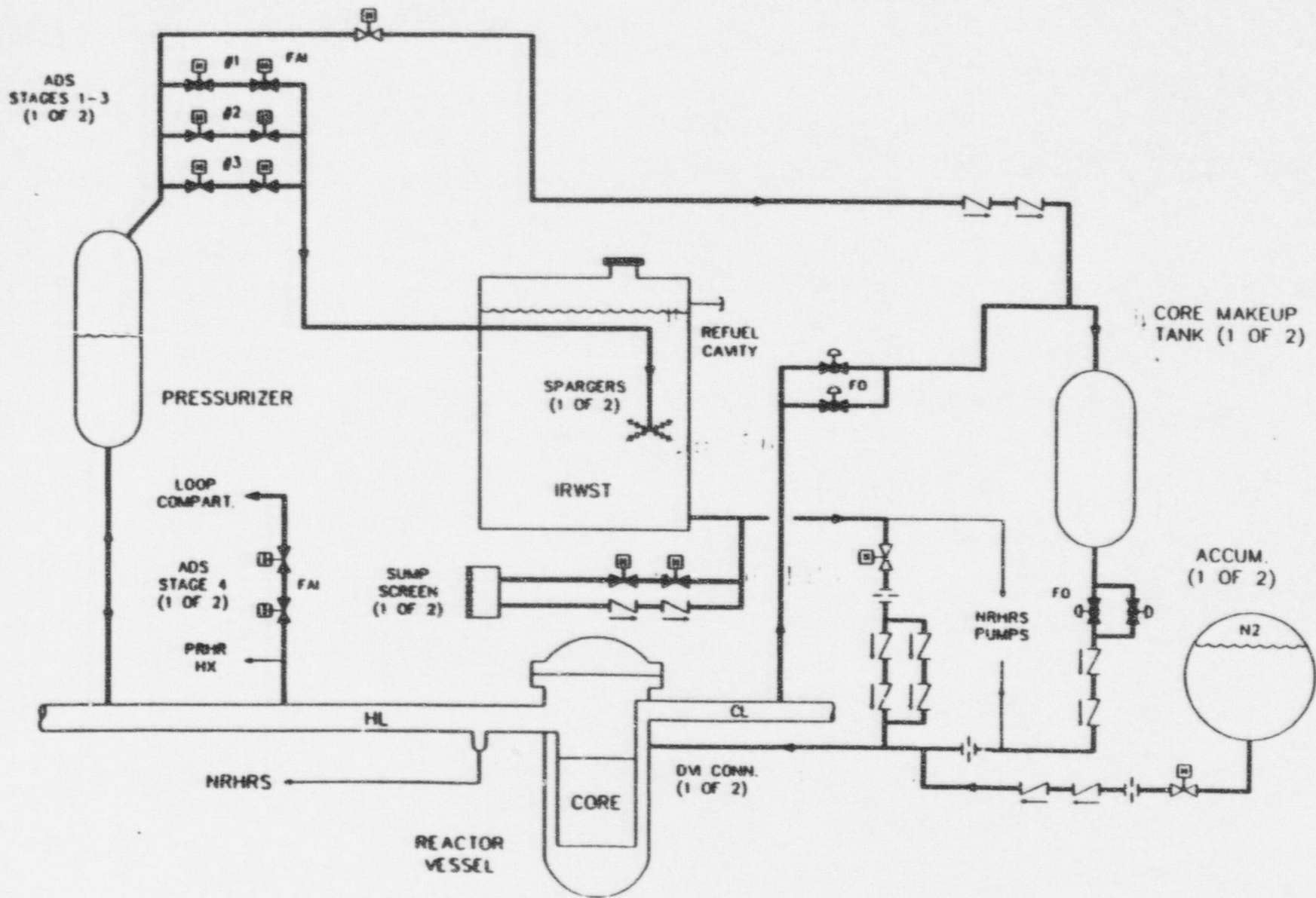

AP600 - LOSS OF OFFSITE POWER

SAFETY CASE

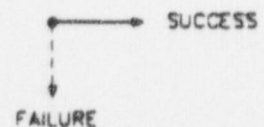
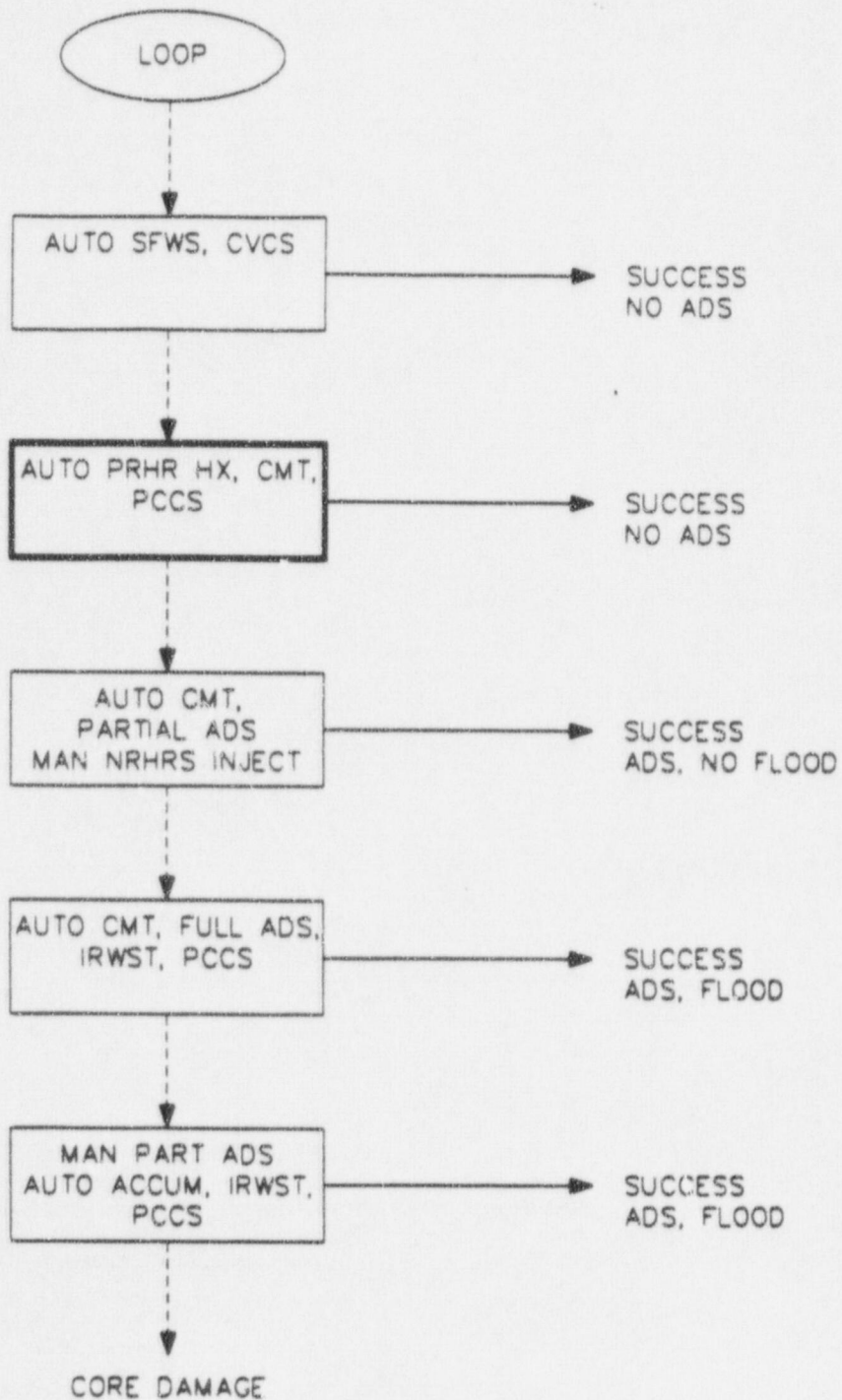

Plant: AP600

Event: LOSS MAIN FEEDWATER at FULL POWER

Function System Order of Use

Actuation / Electrical Systems							
Non-Safety			Safety		Diverse		
PLS	DC	AC	PMS(1)	DC	DAS	HW	
o Reactor Shutdown							
1. Control Rods	-	-	-	A	-	-	-
2. Control Rods	-	-	-	-	-	A	-
3. Control Rods	-	-	-	-	-	-	M
4. Ride Out (2)	M	Yes	Yes	-	-	A	M
o RCS Inventory Control							
1. CVS	A	Yes	Yes	-	-	-	-
2. CMT	-	-	-	A	-	-	-
3. CMT	-	-	-	-	-	A	-
4. CMT	-	-	-	-	-	-	M
5. CMT, RNS, part ADS	M	Yes	Yes	A	Yes	-	-
6. CMT, IRWST, full ADS	-	-	-	A	Yes	-	-
7. Accum, RNS, part ADS	M	Yes	Yes	-	Yes	-	M
8. Accum, IRWST, full ADS	-	-	-	-	Yes	-	M
o RCS Heat Removal							
1. SFW	A	Yes	Yes	-	-	-	-
2. PRHR HX	-	-	-	A	-	-	-
3. PRHR HX	-	-	-	-	-	A	-
4. PRHR HX	-	-	-	-	-	-	M
5. CMT, RNS, part ADS	M	Yes	Yes	A	Yes	-	-
6. CMT, IRWST, full ADS	-	-	-	A	Yes	-	-
7. Accum, RNS, part ADS	M	Yes	Yes	-	Yes	-	M
8. Accum, IRWST, full ADS	-	-	-	-	Yes	-	M
o Containment Cooling							
1. Fan Coolers	A	Yes	Yes	-	-	-	-
2. CV external air, water drain	-	-	-	A	-	-	-
3. CV external air, water drain	-	-	-	-	-	A	-
4. CV external air, water drain	-	-	-	-	-	-	M
5. CV external water fire sys only	M	Yes	Yes	-	-	-	-
6. CV external air only	-	-	-	-	-	-	-

Notes:

- 1) Safety components have safety related MCB manual controls via both individual soft control switches and dedicated system level switches.
- 2) Reactor is shut down by negative moderator temperature coefficient as the coolant heats up. Requires automatic RCS pressure relief, turbine trip, and PRHR HX actuation. Also requires manual CMT or CVS boration.

AP600 - RCS LEAK (0-3/8")

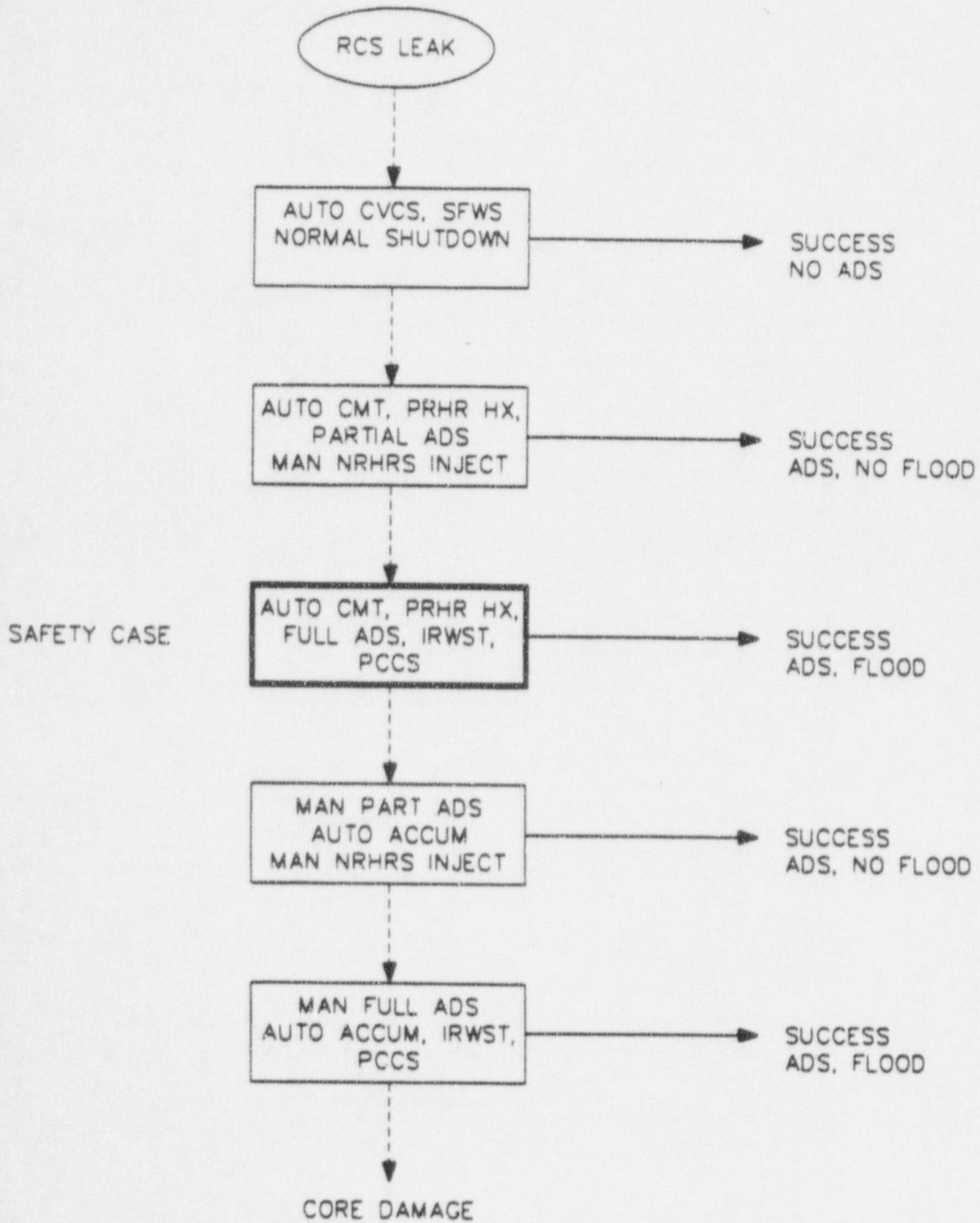

→ SUCCESS
- - - FAILURE

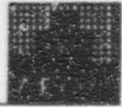

ADS DEFENSE-IN-DEPTH

- **DBA Performance**

- Conservative decay heat, line resistances, pressure drop calc, containment pressure
- Successful IRWST gravity injection achieved with single failure
 - Limiting failure is one 4th stage valve or one battery train (causes failure of one 1st & 3rd stage valves)

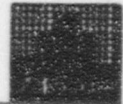

ADS DEFENSE-IN-DEPTH (Continued)

- **PRA Performance**

- Best estimate decay heat, line resistances, pressure drop calc, containment pressure
- Successful IRWST gravity injection achieved with multiple failures
 - Can tolerate common mode failure of all stage 1/2/3 valves or all stage 4 valves
- Successful RNS pump injection achieved with opening of any **one** 2/3/4 stage line

- **ADS sizing basis provides substantial margin and failure tolerance**

AP600

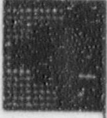

Passive Safety System Capabilities During Shutdowns



PASSIVE CAPABILITY DURING SHUTDOWNS

- **Passive Safety Functions Provided During All Shutdown Modes**
- **Hot Shutdown / Hot Standby / Cold Shutdown Same As At Power**
 - Tech Spec require PRHR HX, CMT, IRWST, and ADS to be available
- **Cold Shutdown Mid-Loop**
 - PRHR HX ineffective (RCS open)
 - CMT / accum unnecessary
 - Tech Spec require:
 - Containment integrity
 - ADS stages 1, 2, 3 open
 - IRWST MOV available
- **Refueling Shutdown**
 - Refueling cavity provides >72 hours with equipment hatch open
 - Equipment hatch can be closed without AC power

AP600 - LOSS OF OFFSITE POWER (HOT/COLD SHUTDOWN) (1)

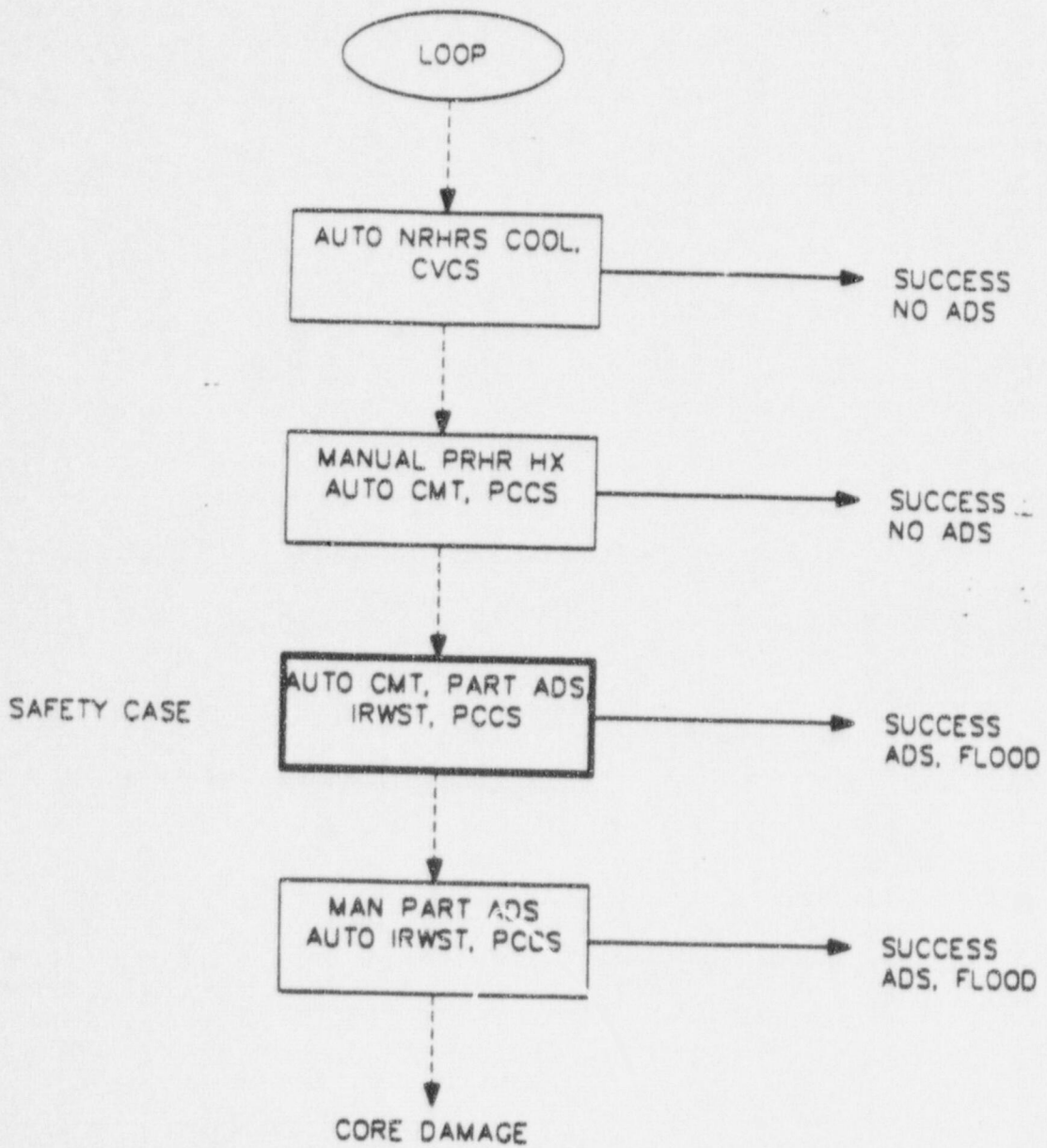

NOTE (1) RCS PRESSURE BOUNDARY IS INTACT IN THIS CASE

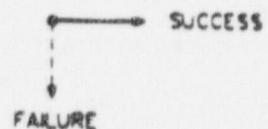

AP600 - LOSS OF OFFSITE POWER (MID-LOOP)

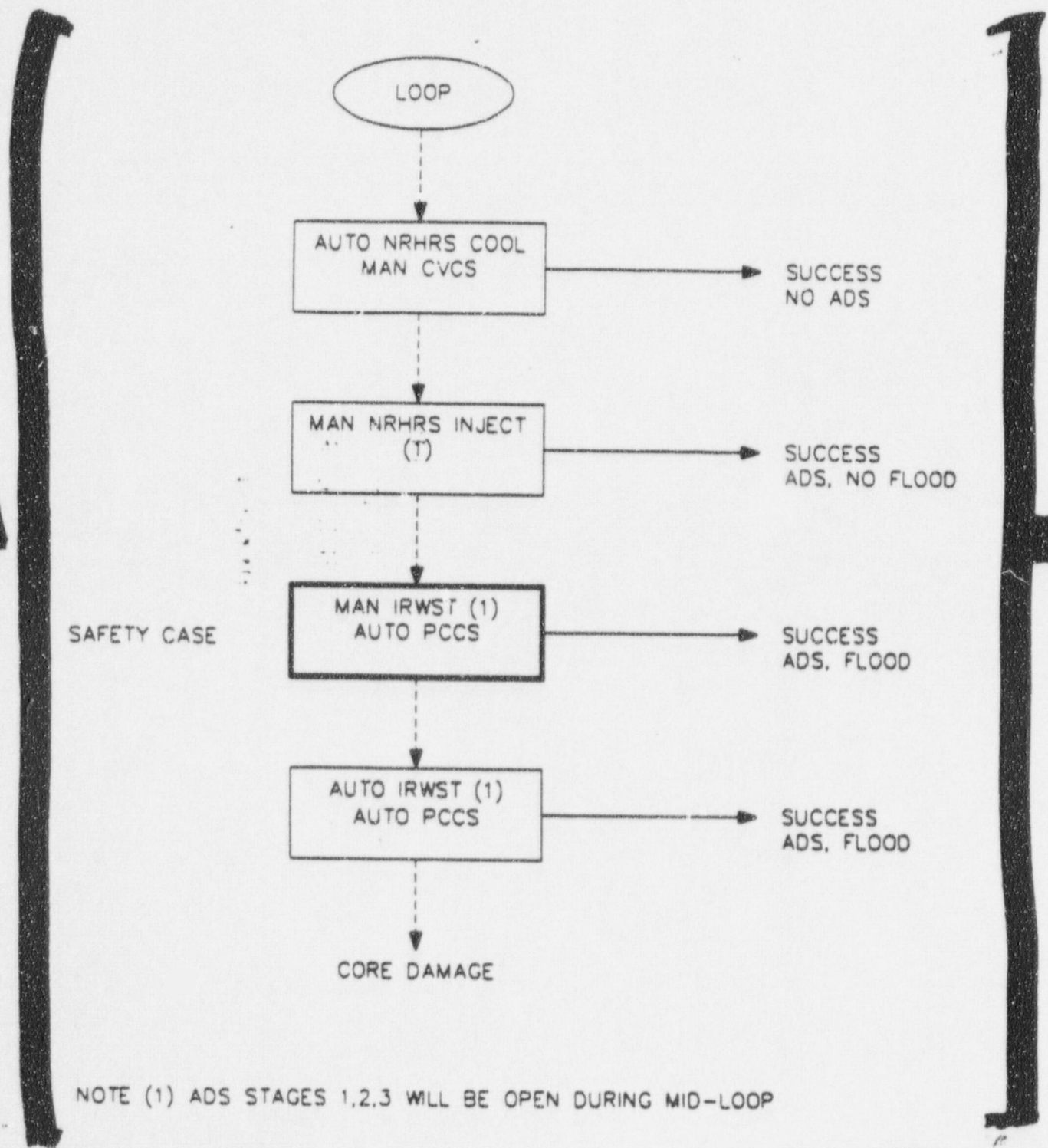

NOTE (1) ADS STAGES 1,2,3 WILL BE OPEN DURING MID-LOOP

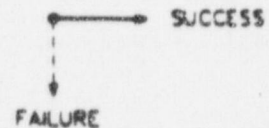

AP600 - LOSS OF OFFSITE POWER (REFUELING)

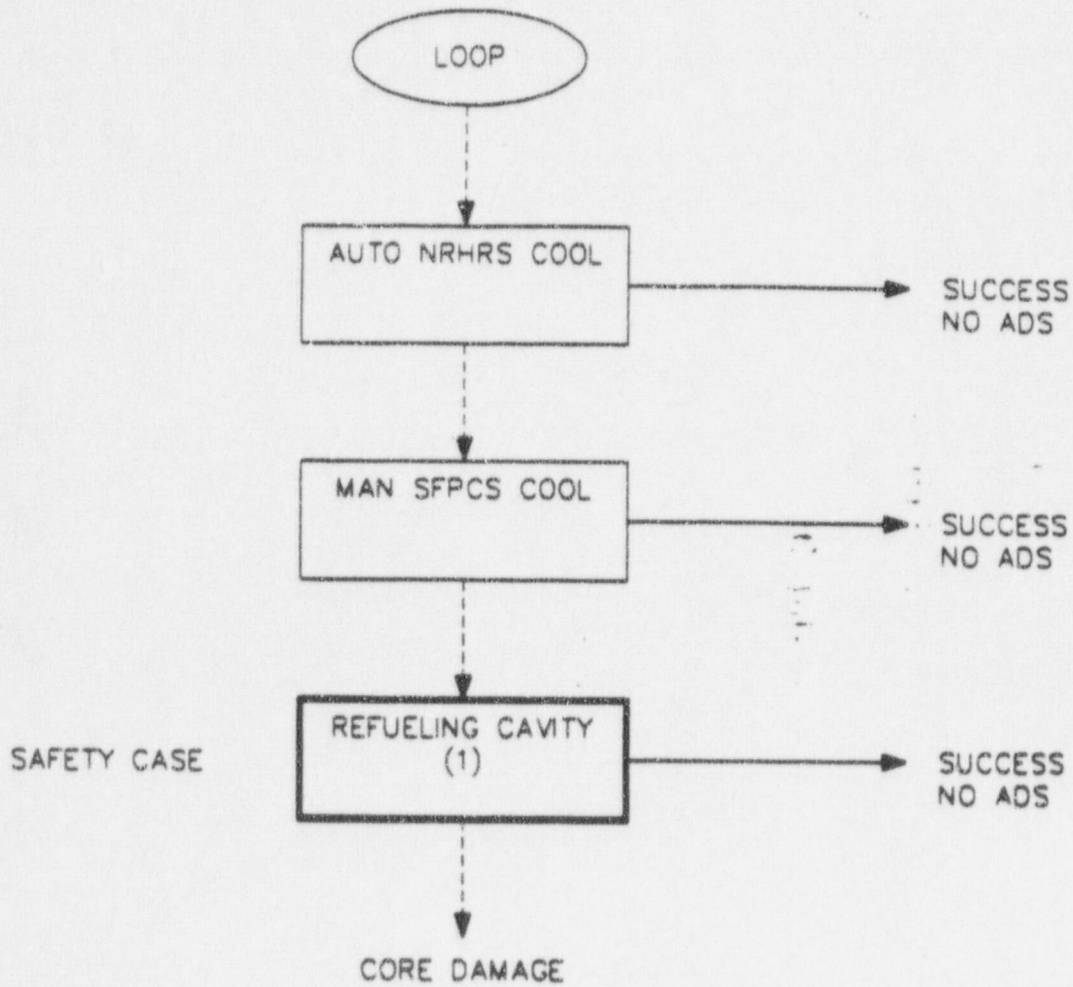

NOTE (1) EITHER CLOSE CONTAINMENT OR PROVIDE ADDITIONAL MAKEUP AFTER 72 --R

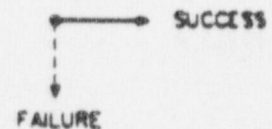

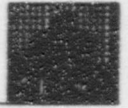

Passive Safety System Long Term Shutdown Capabilities

- After 72 hours
- Hurricane Andrew

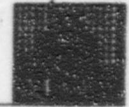

POST 72 HOUR ACTIONS

- **Long Term Passive Safety System Operation**

- Core cooling and ultimate heat sink remain available indefinitely (>> 72 hours) without operator action or offsite support
- Other safety functions require limited offsite support after 72 hours
- Limited offsite support after 72 hours
 - Uses readily accessible and transportable equipment and supplies from offsite
 - Safety-related connections provided to engage offsite support equipment
- Installed nonsafety systems NOT required to sustain safety system functions
 - **Recovery to cold conditions accomplished when nonsafety systems are made available**

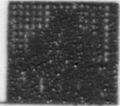

POST 72 HOUR ACTIONS

- **Safety System Extended Support Actions**

- Provide makeup water into containment
 - Only needed after one month assuming DBA containment leakage
- Provide makeup water to the passive containment cooling water storage tank
 - Air cooling alone maintains containment pressure below design pressure
- Provide electrical power to supply the post-accident and spent fuel pit monitoring instrumentation
- Provide electrical power to the hydrogen recombiners
 - Only needed for events where containment hydrogen buildup is a concern

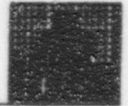

POST 72 HOUR ACTIONS

- **Safety System Extended Support Actions** (continued)
 - Provide breathable, compressed air for the control room air supply and pressurization system
 - Only required in case of serious core damage and containment leakage
 - Provide control room cooling and air recirculation
 - Only required in hot weather conditions
 - Provide ventilation cooling to post-accident monitoring equipment rooms
 - Only required in hot weather conditions
 - Provide makeup water to the spent fuel pit
 - 7 days at BOL, 21 days at EOL
 - 72 hr for worst case emergency core unload

HURRICANE ANDREW/AP600 CAPABILITY

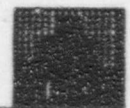

CORE COOLING/DECAY HEAT REMOVAL

Turkey Point Actions

- Shutdown in advance ($T < 350^{\circ}\text{F}$)
- D/Gs tested in advance
- RHR system used to cool core
- Power from D/Gs after loss of grid
- Maintained potential for cooling via SGs with auxiliary feed pump
- Stayed on D/G for nearly 7 days until reliable offsite source restored

AP600 Capabilities

- Redundant D/Gs and normal RHR provide equivalent capability as used at Turkey Point
- Cooling via SGs and Startup Feedwater Pumps available to backup RHR
- Passive systems backup normal systems and D/Gs

HURRICANE ANDREW/AP600 CAPABILITY

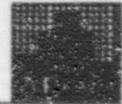

AP600 PASSIVE SYSTEM BACKUP CAPABILITY

- Passive Systems not needed unless both D/Gs are lost \Rightarrow Station Blackout
- Upon station blackout PRHR would be actuated - natural circulation cooling to IRWST - boiloff to containment after 7 hours -- heat removal through containment shell -- condensate return to IRWST
- PRHR maintains RCS at $T < 450^{\circ}\text{F}$, $p < 425$ psia, no primary inventory loss
- Continue on PRHR indefinitely as long as 1E battery capacity can be maintained - 20 kw AC generator within 24 hours is sufficient
- If 24 hour 1E battery nears depletion, ADS is actuated (RCS @ $\sim T = 425^{\circ}\text{F}$, $p = 310$ psia)
- Continue to cool core indefinitely via recirculation within containment

HURRICANE ANDREW/AP600 CAPABILITY

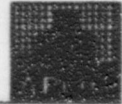

STRUCTURAL DESIGN

Turkey Point Safety Related Structures

- No damage
- Tornado design loads more limiting than wind design loads

AP600 Safety Related Structures

- Also tornado limited, no damage

Turkey Point Non-Safety Related Structures

- Built to South Florida building code
- Majority of structures survived Andrew well
- Central receiving facility had damage to structure and some contents

AP600 Non-Safety Related Structures

- Standard design - limiting wind is South Florida - URD 110 mph/50 year
- Expected to survive Hurricane Andrew

AP600

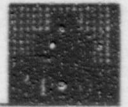

Nonsafety Defense-In-Depth System Safety Isolation Functions

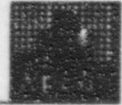

NONSAFETY SYSTEM ISOLATION FUNCTIONS

- **Nonsafety Systems Provide Some Safety Related Isolation Functions**
 - RCS pressure boundary isolation
 - Containment isolation
 - Other isolation functions provided to mitigate DBA's

- **These Isolation Capabilities Are Fully Safety Related**
 - Single failure capability
 - Reg Guide 1.26 quality group A, B, or C
 - Seismic I
 - Tech Spec controls
 - Described in SSAR and ITAAC

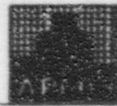

NONSAFETY SYSTEM ISOLATION FUNCTIONS

- **Example: CVS Functions**
- **CVS Functions**
 - Safety Functions
 - RCS pressure boundary isolation
 - Containment penetration isolation
 - Boron dilution accident termination
 - Excessive makeup isolation
 - DID functions
 - RCS makeup for leaks
 - RCS pressure reduction

SAFETY RELATED ISOLATION

AP600 - CHEMICAL AND VOLUME CONTROL SYSTEM

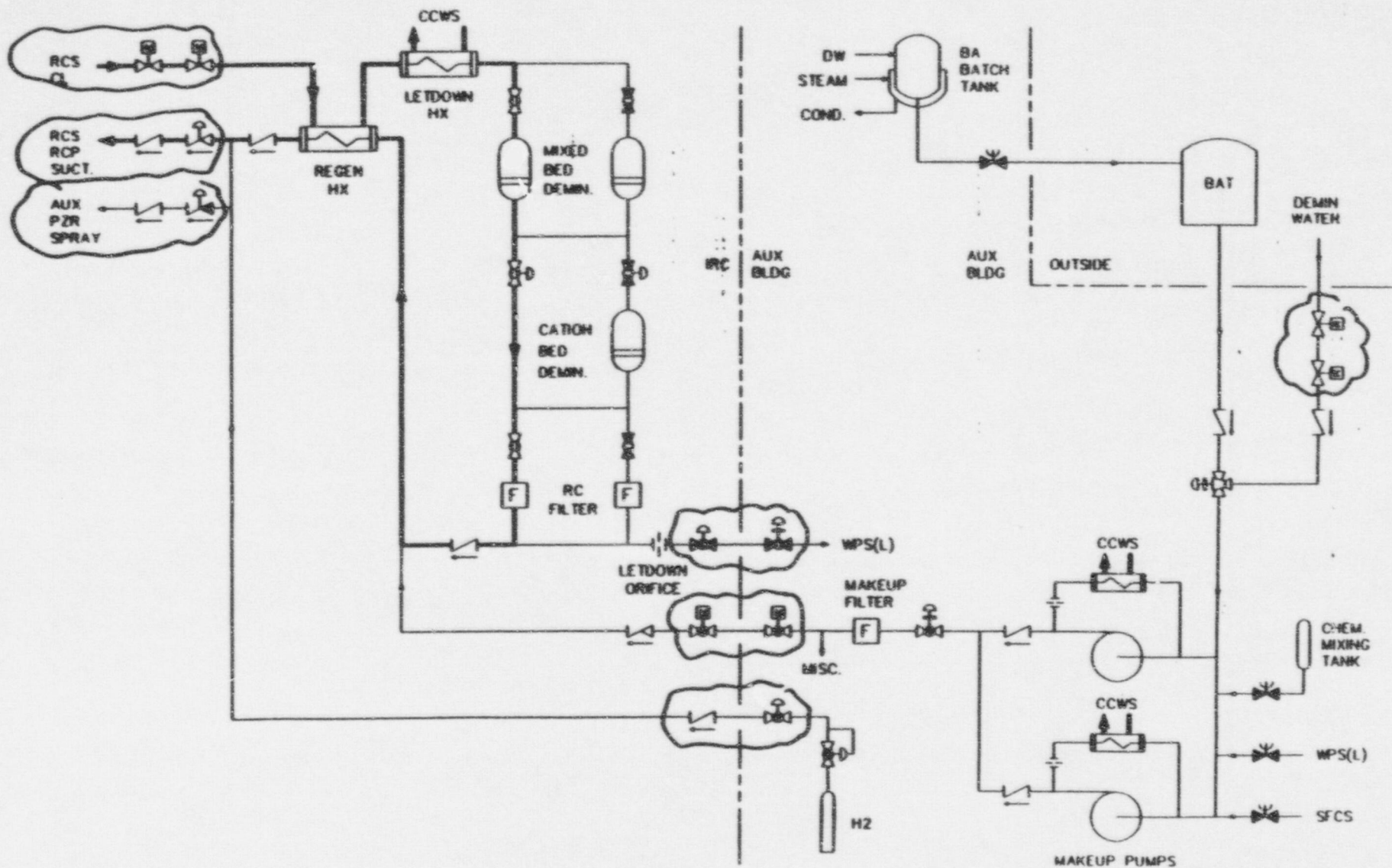

SAFETY RELATED PIPING

AP600 - CHEMICAL AND VOLUME CONTROL SYSTEM

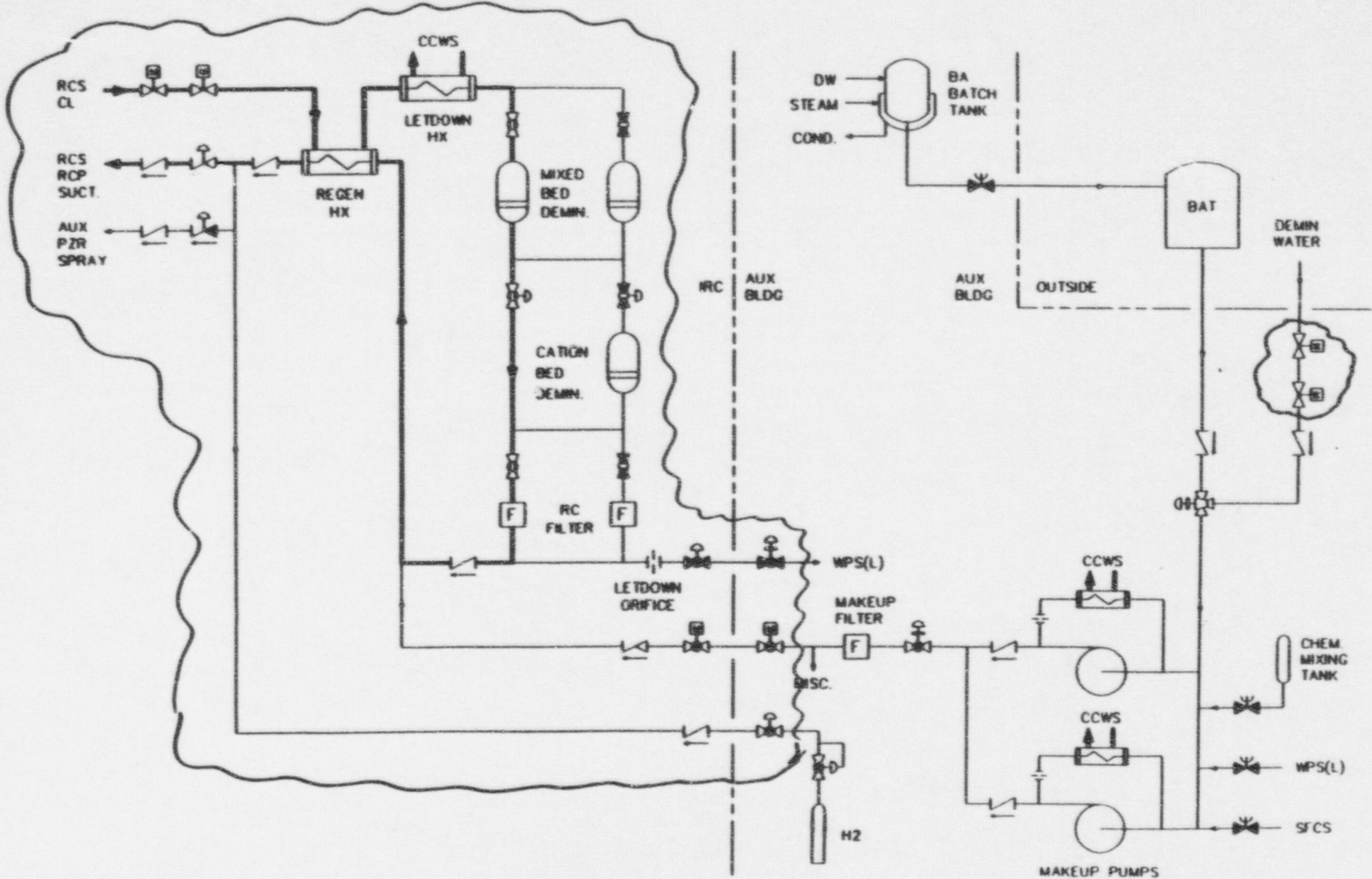

NON SAFETY DID FUNCTIONS

AP600 - CHEMICAL AND VOLUME CONTROL SYSTEM

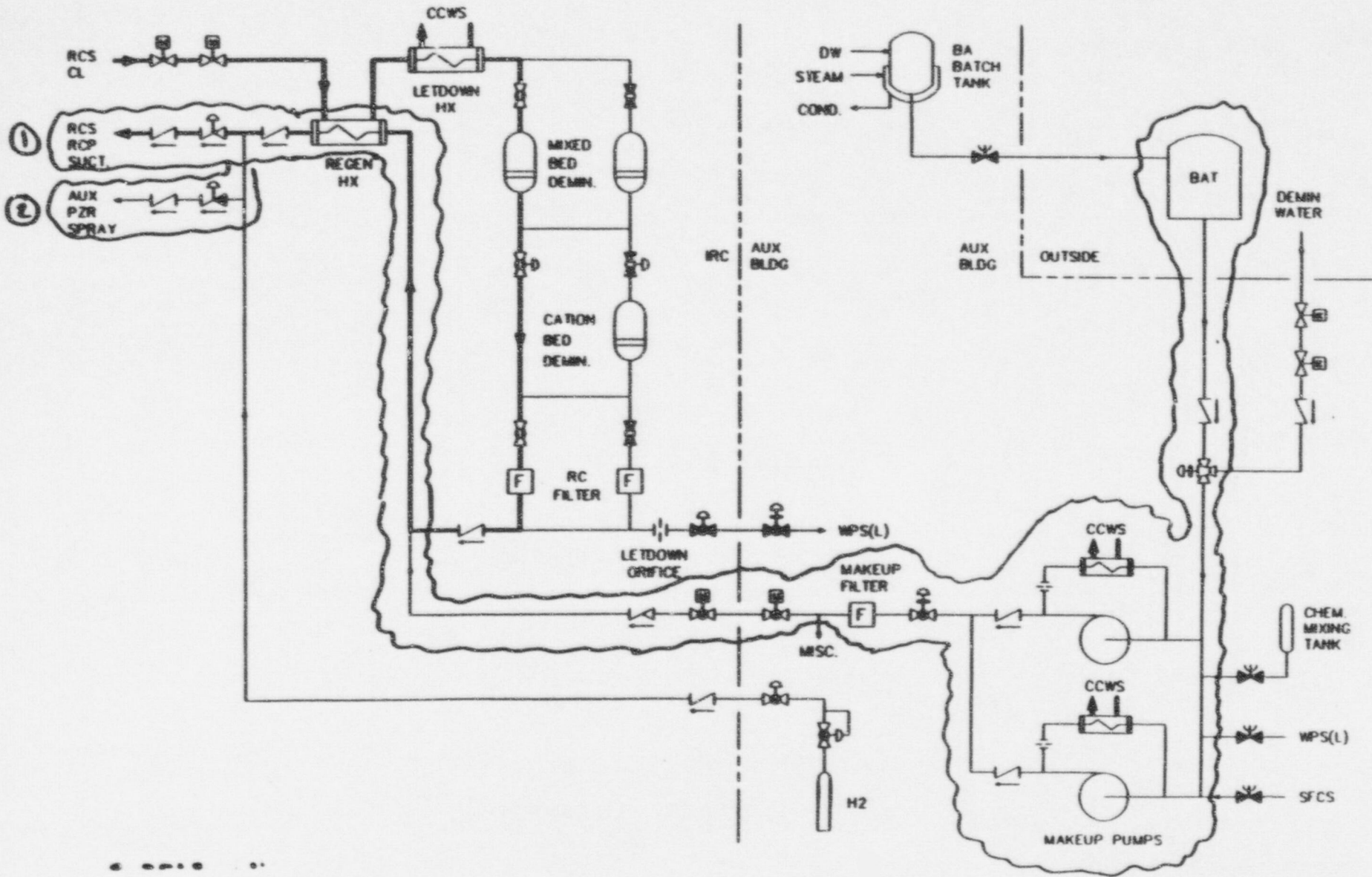

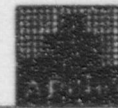

Reliability of Important Systems / Components

501-00

501-00-001-001

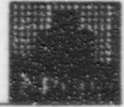

RELIABILITY OF SYSTEMS/COMPONENTS

- **Importance of Systems / Components Identified in AP600 PRA**
 - PRA functions identified in SSAR descriptions

- **Reliability Controlled By Design / Construction / Operation Activities**
 - Design; PRA insights / importance, historical experience, equipment vendor inputs, feasibility testing (where required)
 - Construction; QA/QC, ITAAC
 - Operation; Tech Spec, IST/ISI, O-RAP



RELIABILITY OF SYSTEMS/COMPONENTS

Design Phase Reliability Activities

- **PRA Insights / Importance**
 - Passive safety systems important
 - Importance ranking
 - IRWST injection
 - PRHR HX
 - ADS stages 1, 2, 3
 - ADS stage 4
 - Accum
 - CMT

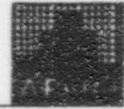

RELIABILITY OF SYSTEMS/COMPONENTS

Design Phase Reliability Activities (Continued)

- **Equipment Requirements Developed To Avoid Historical Problems**
 - Utility inputs
 - Equipment vendor inputs
 - Incorporate into E-Spec
 - Do not specify component reliability
 - Vendors don't know quantitative reliability
 - Vendors unwilling to quote; at best will increase cost to cover their risk

- **Feasibility Testing As Required**
 - Only Required for IRWST check valves and ADS valves
 - Demonstrates operability not reliability
 - Use historical reliability for all valves

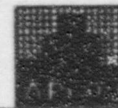

INSPECTIONS, TESTS, ANALYSES AND ACCEPTANCE CRITERIA

B. A. McINTYRE, MANAGER

ADVANCED PLANT SAFETY AND LICENSING

AP600 ITAAC PROGRAM



- o AP600 ITAAC PROGRAM WILL BE DIFFERENT
- o SCREENING CRITERIA
- o DECEMBER 15, 1992 SUBMITTAL
 - o 36 SYSTEM ITAAC
 - o 12 SAFETY SYSTEMS
 - o 24 NONSAFETY SYSTEMS
 - o DEFENSE IN DEPTH AND SUPPORT
- o NONSYSTEM ITAAC
 - o HUMAN FACTORS
 - o NUCLEAR ISLAND BUILDING
 - o SAFETY RELATED PIPING
 - o INTERFACE

TIER 1 Design Description/ITAAC Screening Criteria Checklist

Purpose: The purpose of this checklist is to determine those systems and structures for which Tier 1 design descriptions and associated ITAACs must be prepared.

I. System or Structure:

II. Evaluation:

A. Are there any structures, systems, or components classified as Class A, B, or C?

YES

NO

Justification:

B. Are there any structures, systems, or components classified as Class D because they provide defense-in-depth functions as defined in GW G1 010, AP600 Nuclear Safety Classification and Seismic Requirement Methodology?

YES

NO

Justification:

III. Conclusion

Tier 1 Design Description and associated ITAAC will be developed for this system.

YES

NO

Justification:

System Engineer/Date _____

Technical Review Team _____

AP600 ITAAC



- o **REACTOR**
 - o Fuel Handling and Refueling System
 - o Reactor Coolant System
 - o Reactor System

- o **NUCLEAR SAFETY SYSTEMS**
 - o Automatic Depressurization System
 - o Containment System
 - o Passive Containment Cooling System
 - o Passive Core Cooling System
 - o Steam Generator System
 - o Main Control Room Habitability System

- o **INSTRUMENTATION AND CONTROL**
 - o Diverse Actuation System
 - o Data Display and Processing System
 - o Incore Instrumentation System
 - o Plant Control System
 - o Protection and Safety Monitoring System
 - o Radiation Monitoring System

AP600 ITAAC



- o **AUXILIARY SYSTEMS**
 - o **Component Cooling Water System**
 - o **Chemical and Volume Control System**
 - o **Standby Diesel and Auxilliary Boiler Fuel Oil System**
 - o **Fire Protection System**
 - o **Mechanical Handling System**
 - o **Primary Sampling System**
 - o **Normal Residual Heat Removal System**
 - o **Spent Fuel Pit Cooling System**
 - o **Service Water System**
 - o **Containment Hydrogen Control System**

- o **STEAM AND POWER CONVERSION SYSTEMS**
 - o **Main and Startup Feedwater System**
 - o **Main Steam System**

AP600 ITAAC

AP600



- o **ELECTRICAL POWER**
 - o **Main AC Power System**
 - o **Non Class 1E DC and UPS System**
 - o **Plant Lighting System**
 - o **Class 1E DC and UPS System**
 - o **Onsite Standby Power System**

- o **HEATING, VENTILATING, AND AIR CONDITIONING SYSTEMS**
 - o **Nuclear Island Nonradioactive Ventilation System**
 - o **Central Chilled Water System**
 - o **Annex/Auxiliary Building Nonradioactive Ventilation System**
 - o **Diesel Generator Building Ventilation System**

AP600 ITAAC PROGRAM

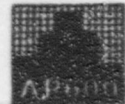

- o **PROGRAM PLANS**
 - o **KEEP ITAAC OFF CRITICAL PATH**
 - o **REVIEWED WITH STAFF, FEBRUARY 16**

- o **MAINTAIN INVOLVEMENT IN INDUSTRY ITAAC ACTIVITIES**
 - o **MARCH 9, GE BUILDING**
 - o **MARCH 9, GE ELECTRICAL DISTRIBUTION**
 - o **ABB/CE INDUSTRY REVIEWS**
 - o **NUMARC ACTIVITIES**

AP600 ITAAC PROGRAM

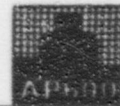

- o UPDATE AP600 TO CURRENT INDUSTRY STANDARDS
 - o FLUID AND MECHANICAL SYSTEMS
 - o APRIL 15, 1993
 - o BUILDING, ELECTRICAL AND I&C
 - o JUNE 1, 1993



TESTING

E. J. PIPLICA, MANAGER

TEST ENGINEERING

AP600 TEST PROGRAM



- DESIGN CERTIFICATION TESTS
 - PASSIVE CONTAINMENT COOLING SYSTEM TESTS
 - PASSIVE CORE COOLING SYSTEM TESTS

- DESIGN VERIFICATION (ENGINEERING) TESTS
 - COMPONENT DESIGN VERIFICATION TESTS

RELATIONSHIP TO THE DESIGN PROCESS



- PERFORM A RANGE OF TESTS TO OBTAIN HIGH FIDELITY DATA
- TEST DATA USED TO DEVELOP OR VERIFY MODELS USED IN EXISTING COMPUTER CODES
- COMPUTER ANALYSIS IS PERFORMED MODELING THE TEST FACILITY GEOMETRY
- SAME COMPUTER CODES ARE USED TO ANALYZE THE PERFORMANCE OF THE AP600
- IF NECESSARY, THE AP600 DESIGN IS OPTIMIZED BASED ON THE RESULTS OF COMPUTER ANALYSIS

PASSIVE CONTAINMENT COOLING SYSTEM TESTS

SCHEDULE AS OF 11/27/81
 SCHEDULE AS OF 11/27/81

● WITNESS POINT
 ▲ DATA REPORT

AP600 TEST PROGRAMS

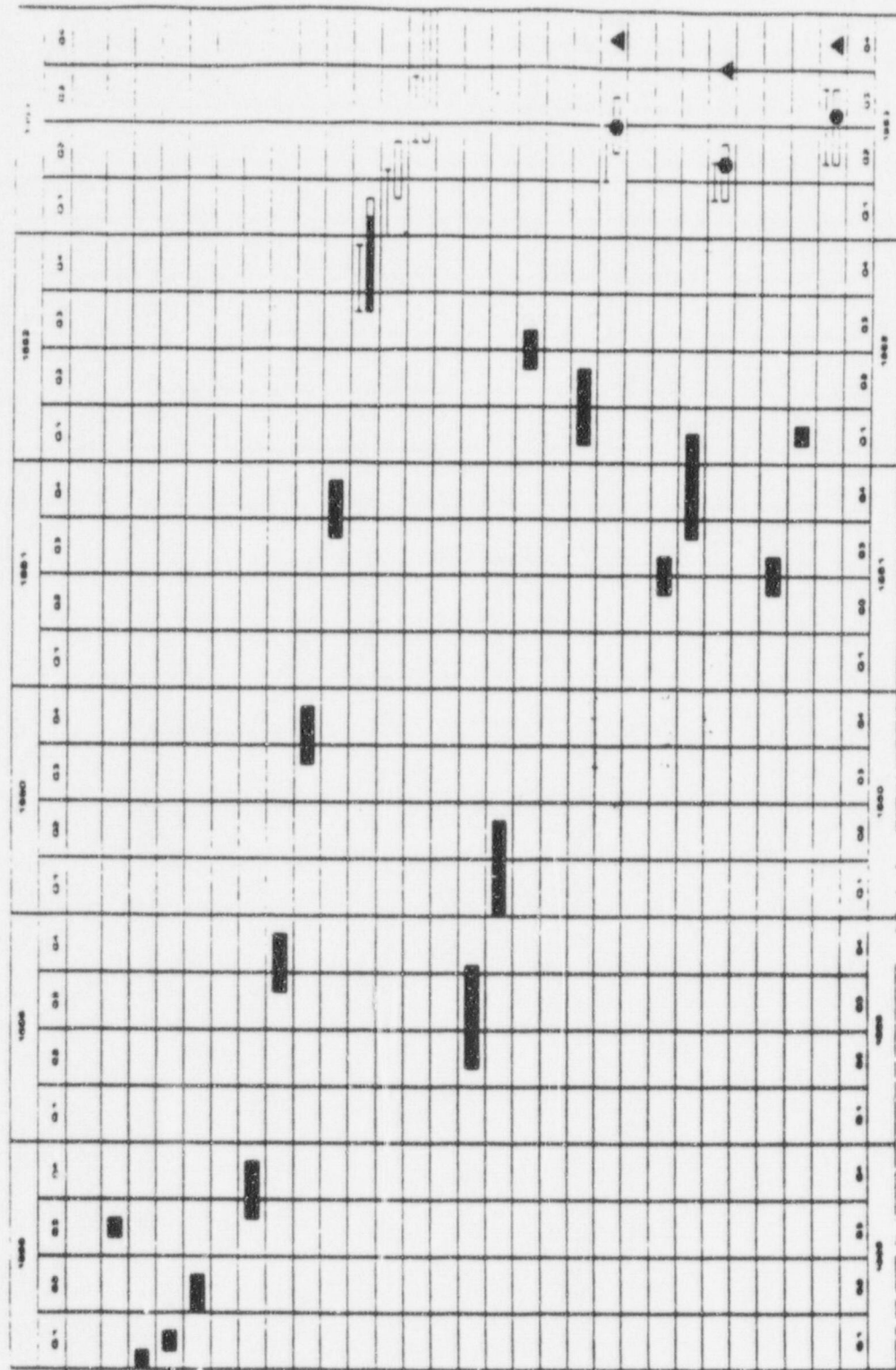

- TEST 1980Q1
1. BENCH SCALE TUNNEL, QUANTIFICATION
 2. AIR FILTRATION BENCH, P 1981
 3. WATER FILM PENETRATION TEST
 4. HEATER PLATE TEST
 5. CONDENSATION TESTS
 - a. BENCH SCALE TUNNEL
 - b. BENCH SCALE TUNNEL
 - c. AIR FILTRATION BENCH
 - d. WATER FILM PENETRATION TEST
 - e. HEATER PLATE TEST
 - f. CONDENSATION TESTS
 6. WATER FILM PENETRATION TEST
 7. CONDENSATION TESTS
 - a. BENCH SCALE TUNNEL
 - b. BENCH SCALE TUNNEL
 - c. AIR FILTRATION BENCH
 - d. WATER FILM PENETRATION TEST
 - e. HEATER PLATE TEST
 - f. CONDENSATION TESTS
 8. CONDENSATION TESTS
 - a. BENCH SCALE TUNNEL
 - b. BENCH SCALE TUNNEL
 - c. AIR FILTRATION BENCH
 - d. WATER FILM PENETRATION TEST
 - e. HEATER PLATE TEST
 - f. CONDENSATION TESTS
 9. CONDENSATION TESTS
 - a. BENCH SCALE TUNNEL
 - b. BENCH SCALE TUNNEL
 - c. AIR FILTRATION BENCH
 - d. WATER FILM PENETRATION TEST
 - e. HEATER PLATE TEST
 - f. CONDENSATION TESTS
 10. CONDENSATION TESTS
 - a. BENCH SCALE TUNNEL
 - b. BENCH SCALE TUNNEL
 - c. AIR FILTRATION BENCH
 - d. WATER FILM PENETRATION TEST
 - e. HEATER PLATE TEST
 - f. CONDENSATION TESTS
 11. CONDENSATION TESTS
 - a. BENCH SCALE TUNNEL
 - b. BENCH SCALE TUNNEL
 - c. AIR FILTRATION BENCH
 - d. WATER FILM PENETRATION TEST
 - e. HEATER PLATE TEST
 - f. CONDENSATION TESTS
 12. CONDENSATION TESTS
 - a. BENCH SCALE TUNNEL
 - b. BENCH SCALE TUNNEL
 - c. AIR FILTRATION BENCH
 - d. WATER FILM PENETRATION TEST
 - e. HEATER PLATE TEST
 - f. CONDENSATION TESTS
 13. CONDENSATION TESTS
 - a. BENCH SCALE TUNNEL
 - b. BENCH SCALE TUNNEL
 - c. AIR FILTRATION BENCH
 - d. WATER FILM PENETRATION TEST
 - e. HEATER PLATE TEST
 - f. CONDENSATION TESTS
 14. CONDENSATION TESTS
 - a. BENCH SCALE TUNNEL
 - b. BENCH SCALE TUNNEL
 - c. AIR FILTRATION BENCH
 - d. WATER FILM PENETRATION TEST
 - e. HEATER PLATE TEST
 - f. CONDENSATION TESTS
 15. CONDENSATION TESTS
 - a. BENCH SCALE TUNNEL
 - b. BENCH SCALE TUNNEL
 - c. AIR FILTRATION BENCH
 - d. WATER FILM PENETRATION TEST
 - e. HEATER PLATE TEST
 - f. CONDENSATION TESTS
 16. CONDENSATION TESTS
 - a. BENCH SCALE TUNNEL
 - b. BENCH SCALE TUNNEL
 - c. AIR FILTRATION BENCH
 - d. WATER FILM PENETRATION TEST
 - e. HEATER PLATE TEST
 - f. CONDENSATION TESTS
 17. CONDENSATION TESTS
 - a. BENCH SCALE TUNNEL
 - b. BENCH SCALE TUNNEL
 - c. AIR FILTRATION BENCH
 - d. WATER FILM PENETRATION TEST
 - e. HEATER PLATE TEST
 - f. CONDENSATION TESTS
 18. CONDENSATION TESTS
 - a. BENCH SCALE TUNNEL
 - b. BENCH SCALE TUNNEL
 - c. AIR FILTRATION BENCH
 - d. WATER FILM PENETRATION TEST
 - e. HEATER PLATE TEST
 - f. CONDENSATION TESTS
 19. CONDENSATION TESTS
 - a. BENCH SCALE TUNNEL
 - b. BENCH SCALE TUNNEL
 - c. AIR FILTRATION BENCH
 - d. WATER FILM PENETRATION TEST
 - e. HEATER PLATE TEST
 - f. CONDENSATION TESTS
 20. CONDENSATION TESTS
 - a. BENCH SCALE TUNNEL
 - b. BENCH SCALE TUNNEL
 - c. AIR FILTRATION BENCH
 - d. WATER FILM PENETRATION TEST
 - e. HEATER PLATE TEST
 - f. CONDENSATION TESTS

1000

PASSIVE CORE COOLING SYSTEMS TESTS

SCHEDULE AS OF 11/21/92
 SCHEDULE AS OF 11/27/93

● 11/21/92 AS OF
 ▲ 11/27/93 AS OF

APBUU TEST PERIODS

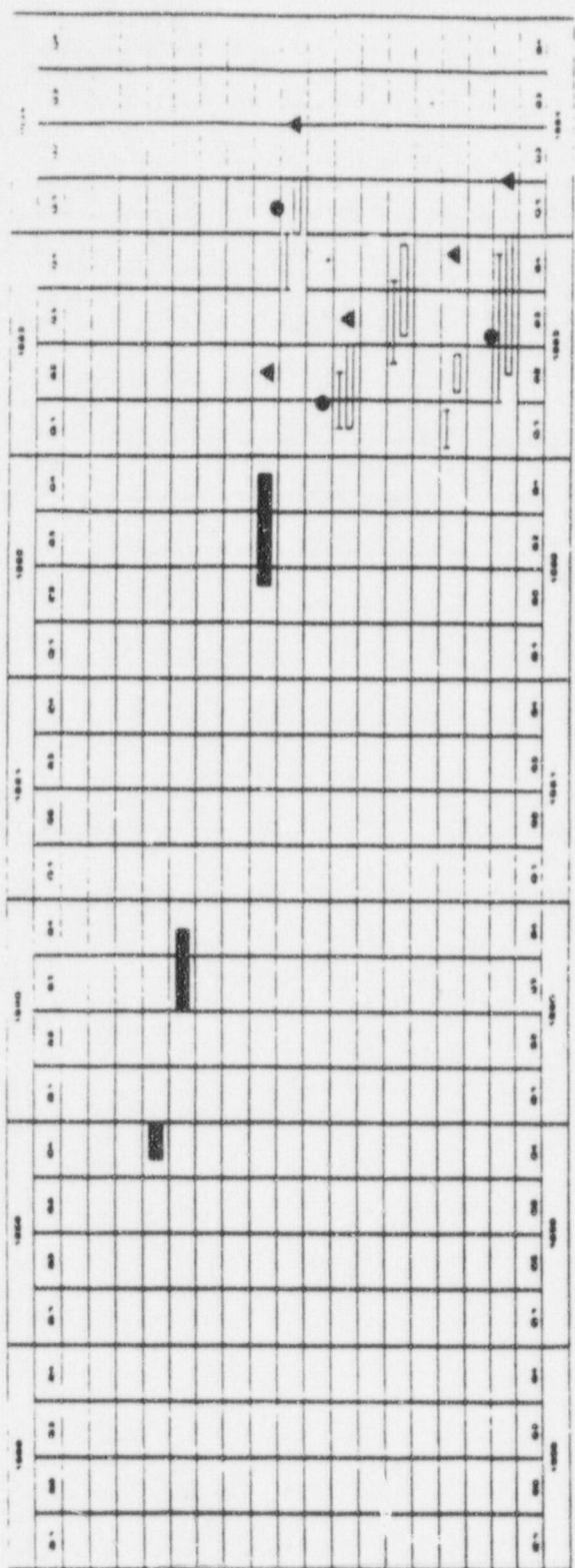

● 11/21/92 AS OF
 ▲ 11/27/93 AS OF
 [] 11/21/92 AS OF
 [] 11/27/93 AS OF

COMPONENT DESIGN VERIFICATION TESTS

SCHEDULE AS OF 11/21/92
 SCHEDULE AS OF 11/19/91

11/2000 AS OF
 11/1999

AP600 TEST PROGRAMS

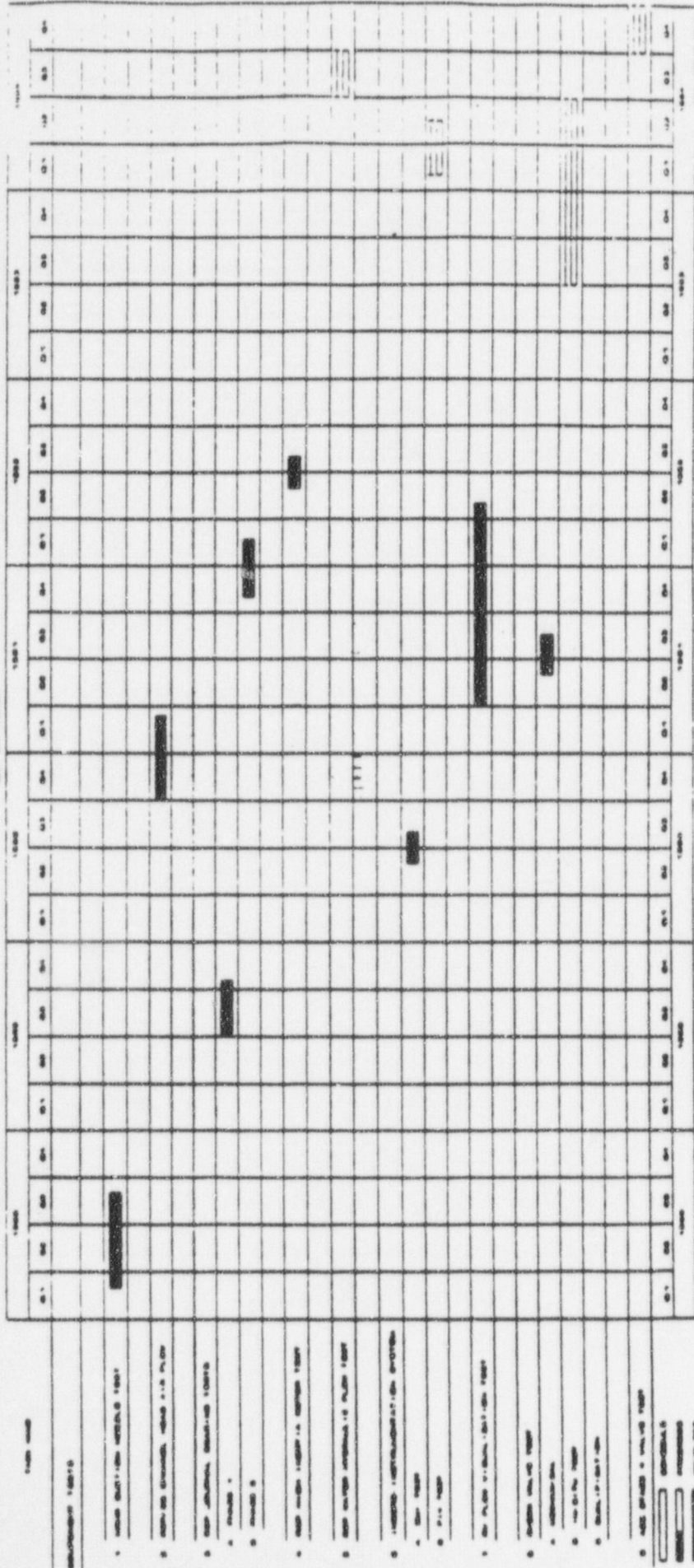

SCHEDULE
 SCHEDULE
 SCHEDULE

● - NRC
 ▼ - A & TRT
 ■ - ENEL

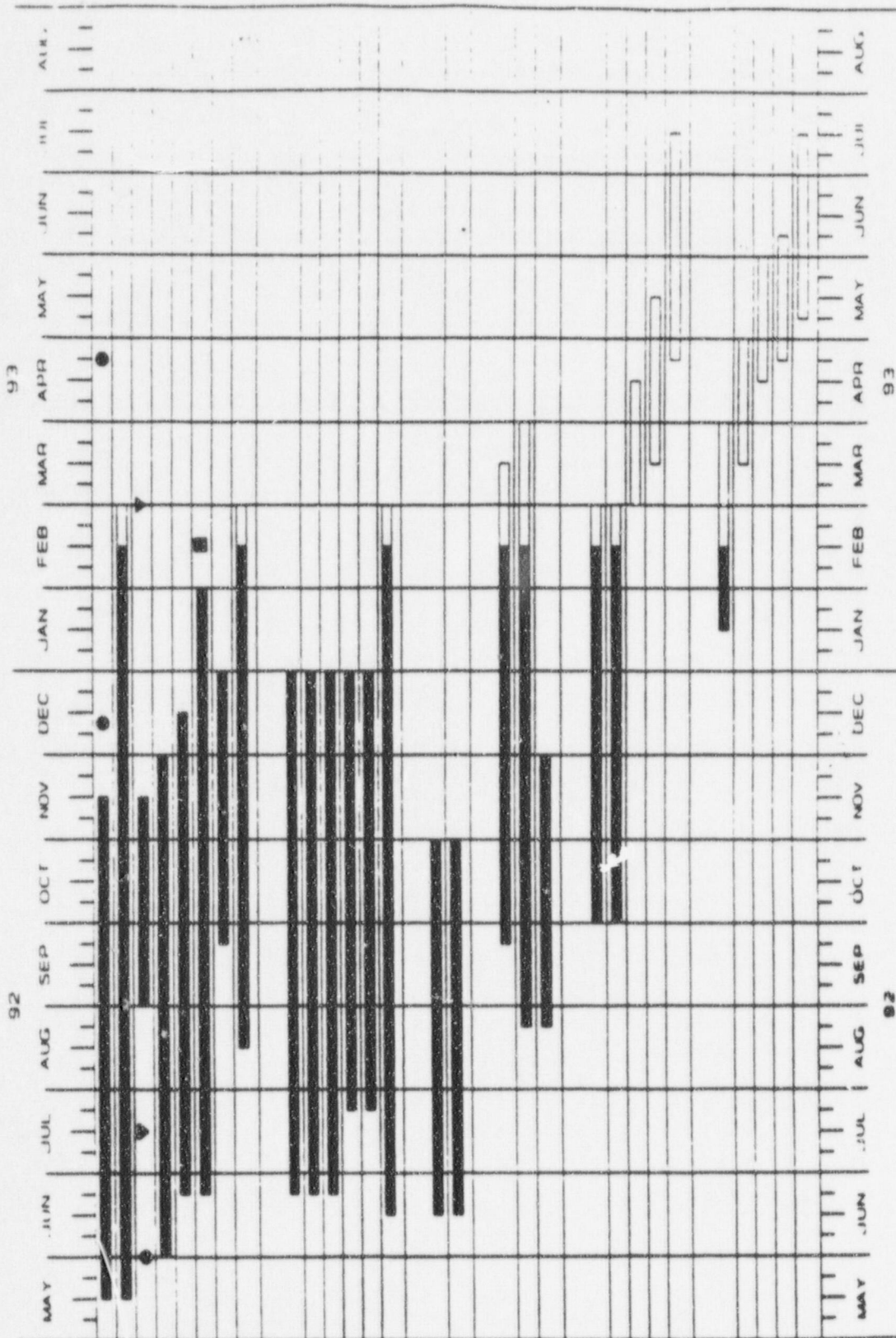

- 1. LOGP-816 TEST - APR 1992
- 2. LOGP-816 TEST - APR 1992
- 3. LOGP-816 TEST - APR 1992
- 4. LOGP-816 TEST - APR 1992
- 5. LOGP-816 TEST - APR 1992
- 6. LOGP-816 TEST - APR 1992
- 7. LOGP-816 TEST - APR 1992
- 8. LOGP-816 TEST - APR 1992
- 9. LOGP-816 TEST - APR 1992
- 10. LOGP-816 TEST - APR 1992
- 11. LOGP-816 TEST - APR 1992
- 12. LOGP-816 TEST - APR 1992
- 13. LOGP-816 TEST - APR 1992
- 14. LOGP-816 TEST - APR 1992
- 15. LOGP-816 TEST - APR 1992
- 16. LOGP-816 TEST - APR 1992
- 17. LOGP-816 TEST - APR 1992
- 18. LOGP-816 TEST - APR 1992
- 19. LOGP-816 TEST - APR 1992
- 20. LOGP-816 TEST - APR 1992
- 21. LOGP-816 TEST - APR 1992
- 22. LOGP-816 TEST - APR 1992
- 23. LOGP-816 TEST - APR 1992
- 24. LOGP-816 TEST - APR 1992
- 25. LOGP-816 TEST - APR 1992
- 26. LOGP-816 TEST - APR 1992
- 27. LOGP-816 TEST - APR 1992
- 28. LOGP-816 TEST - APR 1992
- 29. LOGP-816 TEST - APR 1992
- 30. LOGP-816 TEST - APR 1992
- 31. LOGP-816 TEST - APR 1992
- 32. LOGP-816 TEST - APR 1992
- 33. LOGP-816 TEST - APR 1992
- 34. LOGP-816 TEST - APR 1992
- 35. LOGP-816 TEST - APR 1992
- 36. LOGP-816 TEST - APR 1992
- 37. LOGP-816 TEST - APR 1992
- 38. LOGP-816 TEST - APR 1992
- 39. LOGP-816 TEST - APR 1992
- 40. LOGP-816 TEST - APR 1992
- 41. LOGP-816 TEST - APR 1992
- 42. LOGP-816 TEST - APR 1992
- 43. LOGP-816 TEST - APR 1992
- 44. LOGP-816 TEST - APR 1992
- 45. LOGP-816 TEST - APR 1992
- 46. LOGP-816 TEST - APR 1992
- 47. LOGP-816 TEST - APR 1992
- 48. LOGP-816 TEST - APR 1992
- 49. LOGP-816 TEST - APR 1992
- 50. LOGP-816 TEST - APR 1992
- 51. LOGP-816 TEST - APR 1992
- 52. LOGP-816 TEST - APR 1992
- 53. LOGP-816 TEST - APR 1992
- 54. LOGP-816 TEST - APR 1992
- 55. LOGP-816 TEST - APR 1992
- 56. LOGP-816 TEST - APR 1992
- 57. LOGP-816 TEST - APR 1992
- 58. LOGP-816 TEST - APR 1992
- 59. LOGP-816 TEST - APR 1992
- 60. LOGP-816 TEST - APR 1992
- 61. LOGP-816 TEST - APR 1992
- 62. LOGP-816 TEST - APR 1992
- 63. LOGP-816 TEST - APR 1992
- 64. LOGP-816 TEST - APR 1992
- 65. LOGP-816 TEST - APR 1992
- 66. LOGP-816 TEST - APR 1992
- 67. LOGP-816 TEST - APR 1992
- 68. LOGP-816 TEST - APR 1992
- 69. LOGP-816 TEST - APR 1992
- 70. LOGP-816 TEST - APR 1992
- 71. LOGP-816 TEST - APR 1992
- 72. LOGP-816 TEST - APR 1992
- 73. LOGP-816 TEST - APR 1992
- 74. LOGP-816 TEST - APR 1992
- 75. LOGP-816 TEST - APR 1992
- 76. LOGP-816 TEST - APR 1992
- 77. LOGP-816 TEST - APR 1992
- 78. LOGP-816 TEST - APR 1992
- 79. LOGP-816 TEST - APR 1992
- 80. LOGP-816 TEST - APR 1992
- 81. LOGP-816 TEST - APR 1992
- 82. LOGP-816 TEST - APR 1992
- 83. LOGP-816 TEST - APR 1992
- 84. LOGP-816 TEST - APR 1992
- 85. LOGP-816 TEST - APR 1992
- 86. LOGP-816 TEST - APR 1992
- 87. LOGP-816 TEST - APR 1992
- 88. LOGP-816 TEST - APR 1992
- 89. LOGP-816 TEST - APR 1992
- 90. LOGP-816 TEST - APR 1992
- 91. LOGP-816 TEST - APR 1992
- 92. LOGP-816 TEST - APR 1992
- 93. LOGP-816 TEST - APR 1992
- 94. LOGP-816 TEST - APR 1992
- 95. LOGP-816 TEST - APR 1992
- 96. LOGP-816 TEST - APR 1992
- 97. LOGP-816 TEST - APR 1992
- 98. LOGP-816 TEST - APR 1992
- 99. LOGP-816 TEST - APR 1992
- 100. LOGP-816 TEST - APR 1992

SCHEDULE
 PRELIMINARY
 LOGP-816

AP600 TEST OBJECTIVES/CONCLUSIONS

Component Design Tests	Test Objective/Conclusion	Completion Date	Test Results Required for		
			SSAR	FDA/DC	Design Verification
Normal BWR Suction Nozzle Test (East Pittsburgh)	Eliminated Suction Vortex	Completed, September 1988			X
Reactor Coolant Pump (RCP) YSG Channelhead Air Flow (Westinghouse EMD)	No SG to Pump Flow Anomalies	Completed, March 1991			X
RCP Journal Bearing (Westinghouse STC)	Demonstrated manufacturability of depleted uranium rotor sections and large radial bearings and determined rotor drag losses	Completed, December 1989 Completed, February 1991			X
o Phase 1 o Phase 2					
RCP High Inertia Rotor (Westinghouse STC)	To optimize rotor drag losses	Completed, August 1992			X
RCP Water Flow (Westinghouse EMD)	To obtain flow, head and efficiency data to accurately predict the performance of the full-scale AP600 reactor coolant pump	September 1994			X
In core Instrumentation Tests					
o Electromagnetic Interference (Westinghouse EMD)	Demonstrated that system is not susceptible to Electromagnetic Interference from the CRDMs	Completed, September 1990			X
o Flow Induced Vibration (facility not chosen)	To demonstrate that the thimble is not subjected to excessive wear	May 1994			X

AP600 TEST OBJECTIVES/CONCLUSIONS

Component; Design Tests (Continued)	Test Objective/Conclusion	Completion Date	Test Results Required for		
			SSAR	FDA/DC	Design Verification
Reactor Vessel Internals Test o Flow Visualization (University of Tennessee) o 1/7 Scale Hydraulic (facility not chosen)	Demonstrated that no abnormal flow distribution occurs in the reactor vessel downcomer and lower plenum To verify the hydraulic characteristics of the AP600 vessel and internals	Completed, February 1992 May 1997			X X
Check Valve o Preliminary Hydraulic (Westinghouse AESD) o In situ (Operating Nuclear Plants) o Qualification Testing (facility not chosen)	Determined flow vs. dP for prototypic check valves To determine opening dP for check valves following prolonged exposure to plant conditions To assess check valve performance	Completed, June 1991 December 1994 (Later)	X		X X
ADS 4th Stage Valve Test (facility not chosen)	To verify valve and operator performance	December 1994			X

AP600 TEST OBJECTIVES/CONCLUSIONS

Passive Safety System Tests	Test Objective/Conclusion	Completion Date	Test Results Required for		
			SSAR	FDA/DC	Design Verification
Passive RHR HX (Westinghouse STC) <ul style="list-style-type: none"> o Phase 1 o Phase 2 	Determined heat transfer characteristics of the PRHR heat exchanger and mixing characteristics in the IRWST	Completed, December 1989 Completed, October 1990	X		
Automatic Depressurization System Test (Cassata, Italy) <ul style="list-style-type: none"> o Phase A Sparger Performance & Tank Loads o Phase B Valve Performance 	Confirmed the capacity of the sparger and determined the dynamic effects on the IRWST structure To simulate operation of the automatic depressurization system and to confirm the capacity and operability of the ADS valves	Completed, November 1992 March 1994		X	
Core Makeup Tank (Westinghouse AESD)	To verify the gravity drain behavior of the core makeup tank over a full range of flow rates and pressures and to verify the operation of the tank level instrumentation	June 1993		X	
Long Term Cooling (1/4 Scale) (Oregon State University)	To provide data to evaluate the operation of the PXS at low pressure	December 1993		X	
DTHB (Columbia University)	To extend the existing critical heat flux correlation for <u>W</u> fuel assemblies at lower flow conditions	June 1993		X	
Full Height Full Pressure Integral Systems Test (SPS 3 facility in Italy)	To provide data to evaluate the operation of the PXS at high pressure, including response to small break LOCA, tube ruptures and steamline break transients	December 1993		X	

AP600 TEST OBJECTIVES/CONCLUSIONS

Passive Containment Cooling Tests	Test Objective/Conclusion	Completion Date	Test Results Required for		
			SSAR	FDA/DC	Design Verification
Integral PCCS Test (Westinghouse STC)	Demonstrated operation of the PCCS over the full range design basis operating conditions	Completed, July 1992	X		
Large Scale PCCS (Westinghouse STC)	To demonstrate operation of the PCCS on a scaled structure which accurately models both the containment dome and sidewall heat transfer areas, and inside containment structures	Phase 1 - May 1992 Phase 2 - June 1993	X	X	
PCCS Water Distribution (Westinghouse AESD)					
Phase 1 Center of Dome, 20' Diameter	Demonstrated the effectiveness of water distribution on the center of the containment dome	Completed, June 1991	X		
Phase 2 Full Scale 1/8 Section	Demonstrated the effectiveness of water distribution on the containment dome and upper sidewall	Completed, January 1992	X		
Phase 3 Full Scale 1/8 Section	Verify design of water distribution system	April 1993			X
PCCS Wind Tunnel (University of Western Ontario)					
o Phase 1 Overall building effects (1/100th scale)	Demonstrated the wind induced pressure on the containment shield building due to air inlet/outlet configurations and site structures	Completed, July 1991	X		
o Phase 2 Detailed Model, Final Verification (1/100th scale)	Determined baffle loading and demonstrated the effect of wind on containment annulus air flow	Completed, February 1992	X		
o Phase 4A, 4B 1/25th scale & 1/50th scale	To perform tests at higher Reynold's numbers and to demonstrate effects of site geography	September 1993		X	

AP600 TESTS IN PROGRESS



- INTEGRAL TESTS
 - SPES-2 FULL HEIGHT FULL PRESSURE TEST
 - OSU 1/4 HEIGHT SCALED PRESSURE TEST
 - PCCS LARGE SCALE HEAT TRANSFER TESTS

- SEPARATE EFFECTS TESTS
 - CORE MAKEUP TANK TEST
 - AUTOMATIC DEPRESSURIZATIONB TEST - PHASE 3

● - NRC
 ▼ - A & TRY
 ■ - ENEL

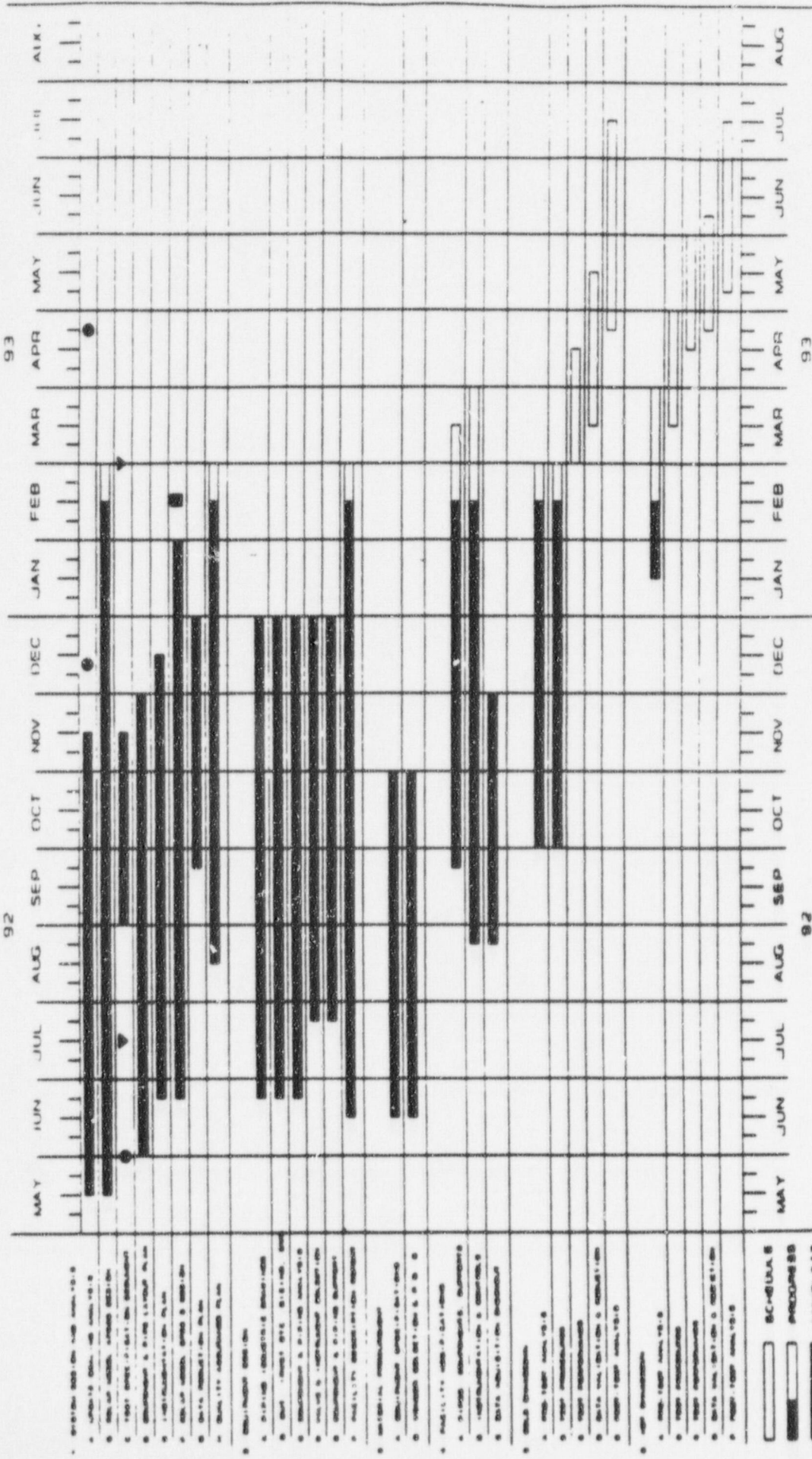

□ SCHEMULA 8
 ■ PROCEEDING 88
 ■ CLEANUP 818

● - NRC
 ▽ - A & TRT
 ■ - ENEL

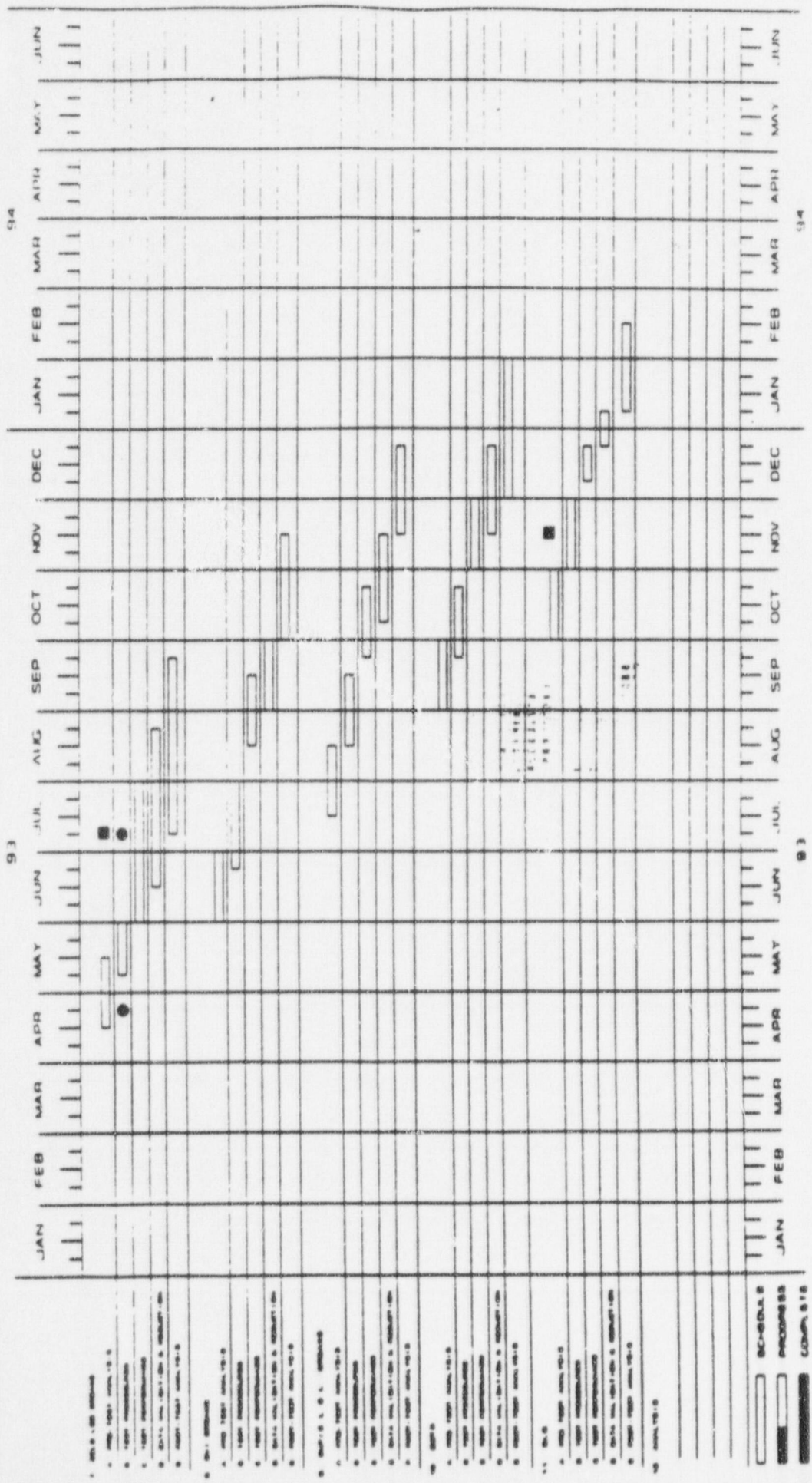

□ SCHEDULE
 ▭ PROGRESS
 ■ COMPLETE

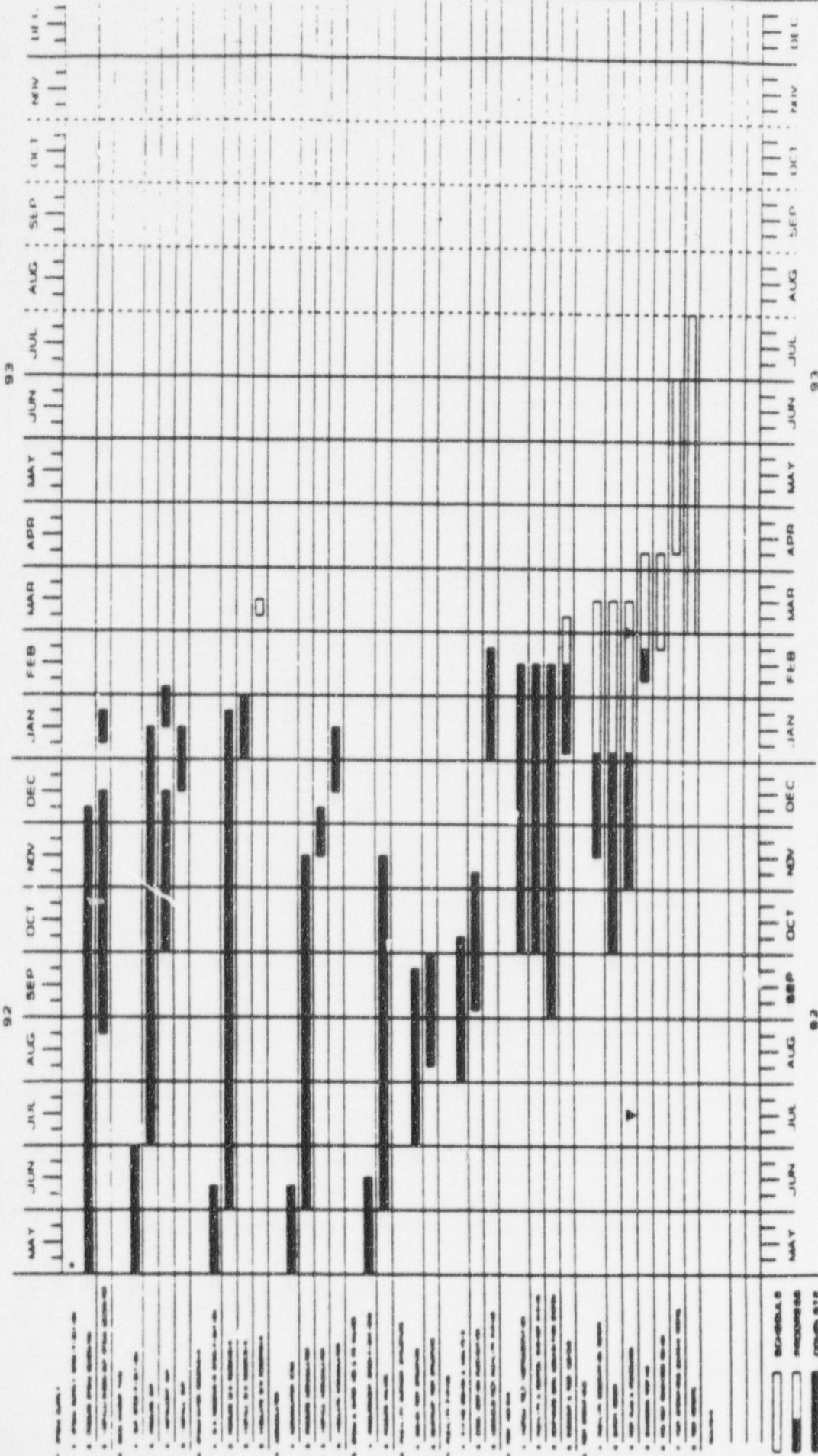

CONCLUSIONS



- COMPREHENSIVE AP600 TEST AND ANALYSIS PROGRAM HAS BEEN DEVELOPED AND IS IN PROGRESS
- DATA FROM TEST PROGRAMS ALREADY INCORPORATED IN SSAR ANALYSIS
- KEY NEW PLANT FEATURES ARE BEING TESTED
- TEST WILL CHARACTERIZE THE UNIQUE FEATURES AT LARGE SCALES SO THAT COMPUTER MODELS CAN BE DEVELOPED OR VERIFIED
- COMBINED TEST AND ANALYSIS PROGRAM WILL MEET THE LICENSING NEEDS
- TEST DATA WILL BE FORWARDED TO THE STAFF AS TEST SERIES ARE COMPLETED
- UPCOMING TESTS ARE BEING CAREFULLY FOLLOWED TO MEET TEST OBJECTIVES AND SCHEDULES



Distribution: Mary Kay
Bill Huffman

Westinghouse
Electric Corporation

Energy Systems

Box 355
Pittsburgh Pennsylvania 15230-0355

DCP/NRC1409
NSD-NRC-98-5753
Docket No. 52-003

August 13, 1998

Document Control Desk
U. S. Nuclear Regulatory Commission
Washington, DC 20555

ATTENTION: T. R. QUAY

SUBJECT: RESPONSE TO NRC LETTERS CONCERNING REQUEST FOR WITHHOLDING
INFORMATION

- Reference:
1. Letter, Sebrosky to McIntyre, "Request for withholding proprietary information for Westinghouse letters dated December 14, 1992, and December 17, 1992," dated July 10, 1998.
 2. Letter, Huffman to McIntyre, "Request for withholding information from public disclosure of Westinghouse AP600 design letters of December 15, 1992," dated July 14, 1998.
 3. Letter, Sebrosky to McIntyre, "Request for withholding information from public disclosure for Westinghouse AP600 design letter of February 24, 1993, April 19, 1993, and July 14, 1993," dated June 18, 1998.
 4. Letter, McIntyre to Quay, "Status review of AP600 proprietary submittals," dated September 18, 1995.

Dear Mr. Quay:

Reference 1 provided the NRC assessment of the Westinghouse claim that proprietary information was provided in a letter dated December 14, 1992, that provided the NRC with copies of presentation material from a management meeting held December 14, 1992, discussing the AP600 testing program. The NRC has no record of a nonproprietary version of the slides being provided. At the time this presentation was made, the information was proprietary since that description of the AP600 testing program had commercial value to Westinghouse. At this time, almost six years later, this information does not have commercial value and is no longer considered to be proprietary by Westinghouse.

Reference 1 also provided the NRC assessment of the Westinghouse claim that proprietary information was provided in a letter dated December 17, 1992, that provided the NRC with copies of presentation material from a meeting with the technical staff held December 9-10, 1992, discussing the AP600

17876 wpf

9808200180
3pp

Enclosure 2

August 13, 1998

testing program. The NRC has no record of a nonproprietary version of the slides being provided. At the time this presentation was made, the information was proprietary since that description of the AP600 testing program had commercial value to Westinghouse. At this time, almost six years later, this information does not have commercial value and is no longer considered to be proprietary by Westinghouse.

Reference 2 provided the NRC assessment of the Westinghouse claim that proprietary information was provided in a letter dated December 15, 1992, that contained a preliminary description of the AP600 refueling outage plan activities. The NRC assessment was that no material in the letter was specifically identified as being proprietary and that a nonproprietary version was not provided. At the time this subject was being discussed with the NRC technical staff, the information was considered to be proprietary by Westinghouse since it contained information that had commercial value to Westinghouse. At this time, almost six years later, this information does not have commercial value and is no longer considered to be proprietary by Westinghouse.

Reference 3 provided the NRC assessment of the Westinghouse claim that proprietary information was provided in a letter dated February 24, 1993, that contained presentation materials from the February 24, 1993, Westinghouse/NRC AP600 senior management meeting. The NRC assessment was that the material was similar to material that exists in the current (1998) nonproprietary version of the AP600 probabilistic risk assessment and AP600 standard safety analysis report. In addition the staff indicated the material was used by the staff in the development of the AP600 draft safety evaluation report and therefore should remain on the docket. Our 1995 request, Reference 4, indicated that the material provided in the Westinghouse letter of February 24, 1993, was presentation material that was intended for clarification only, not part of the formal review material and requested that the material be returned to Westinghouse. At the time this subject was being discussed with the NRC technical staff, the information was considered to be proprietary by Westinghouse since it contained information that had commercial value to Westinghouse. If this presentation material was indeed used by the staff in development of the AP600 draft final safety evaluation report in November 30, 1994, then at this time, over five years later, this information is no longer considered to be proprietary by Westinghouse.

Reference 3 provided the NRC assessment of the Westinghouse claim that proprietary information was provided in a letter dated April 19, 1993, that contained presentation materials from the April 20, 1993, AP600 overview. The NRC assessment was that the material was similar to material that exists in the current (1998) nonproprietary version of the AP600 probabilistic risk assessment and AP600 standard safety analysis report. In addition the staff indicated the material was used by the staff in the development of the AP600 draft safety evaluation report and therefore should remain on the docket. Our 1995 request, Reference 4, indicated that the material provided in the Westinghouse letter of April 19, 1993, was presentation material that was intended for clarification only, not part of the formal review material and requested that the material be returned to Westinghouse. At the time this subject was being discussed with the NRC technical staff, the information was considered to be proprietary by Westinghouse since it contained information that had commercial value to Westinghouse. If this presentation material was indeed used by the staff in development of the AP600 draft final safety evaluation report in November 30, 1994, then at this time, over five years later, this information is no longer considered to be proprietary by Westinghouse.

August 13, 1998

Reference 3 provided the NRC assessment of the Westinghouse claim that proprietary information was provided in a letter dated July 14, 1993, that contained presentation materials from the July 14, 1993, meeting where the AP600 main control room habitability was discussed. The NRC assessment was that the material was similar to material that exists in the current (1998) nonproprietary version of the AP600 probabilistic risk assessment and AP600 standard safety analysis report. In addition the staff indicated the material was used by the staff in the development of the AP600 draft safety evaluation report and therefore should remain on the docket. Our 1995 request, Reference 4, indicated that the material provided in the Westinghouse letter of July 14, 1993, was presentation material that was intended for clarification only, not part of the formal review material and requested that the material be returned to Westinghouse. At the time this subject was being discussed with the NRC technical staff, the information was considered to be proprietary by Westinghouse since it contained information that had commercial value to Westinghouse. If this presentation material was indeed used by the staff in development of the AP600 draft final safety evaluation report in November 30, 1994, then at this time, over five years later, this information is no longer considered to be proprietary by Westinghouse.

This response addresses the proprietary issues delineated in the references.

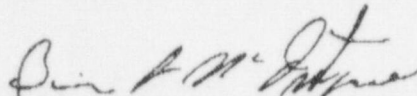

Brian A. McIntyre, Manager
Advanced Plant Safety and Licensing

jml

cc: J. W. Roc - NRC/NRR/DRPM
J. M. Sebrosky - NRC/NRR/DRPM
W. C. Huffman - NRC/NRR/DRPM
H. A. Sepp - Westinghouse