

POINT BEACH NUCLEAR PLANT  
UNITS 1 AND 2

OFFSITE DOSE CALCULATION MANUAL

WISCONSIN ELECTRIC POWER COMPANY

September 1987

Revision 1

## TABLE OF CONTENTS

- 1.0 Offsite Dose Calculation Manual Administration
  - 1.1 Purpose
  - 1.2 General Responsibilities
  - 1.3 Manual Revisions
  
- 2.0 Radiation Monitoring System (RMS)
  
- 3.0 Methodology for Determining RMS Alert and Alarm Setpoints
  - 3.1 Introduction
  - 3.2 Objective
  - 3.3 Alert Setpoint Guidelines
  - 3.4 Alarm Setpoint Guidelines
  - 3.5 Monitor Calibration and Calibration Constant Determination
  - 3.6 Determination of Liquid Effluent Monitor Alarm Setpoints
  - 3.7 Determination of Gaseous Effluent Monitor Alarm Setpoints
  
- 4.0 Demonstrating Compliance with 10 CFR 50, Appendix I
  - 4.1 Introduction
  - 4.2 Dose Limits
  - 4.3 Release Limits
  - 4.4 EPA Regulations
  
- 5.0 Calculation and Comparison of Effluent Releases to Release Limits
  - 5.1 Definitions
  - 5.2 Calculation of Liquid Effluent Releases
  - 5.3 Calculation of Gaseous Effluent Releases
  - 5.4 Tritium in Liquid and Gaseous Effluents
  - 5.5 Quarterly Summary
  
- 6.0 Manual Calculation of Doses Resulting From Effluents
  - 6.1 Basis
  - 6.2 Meteorology
  - 6.3 Procedure for Gaseous Effluents
  - 6.4 Procedure for Liquid Effluents
  
- 7.0 Computer Calculations of Doses Resulting from Effluents
  
- 8.0 Radiological Environmental Monitoring Program

## LIST OF TABLES AND FIGURES

### SECTION 2.0

Table 2-1	Radioactive Liquid Waste Effluent Monitors
Table 2-2	Radioactive Gaseous Waste Effluent Monitors
Figure 2-1	Radioactive Liquid Waste Effluent Monitors
Figure 2-2	Radioactive Gaseous Waste Effluent Monitors

### SECTION 3.0

Table 3-1	Summary of Liquid Dilution and Effluent Pathway Flow Rates
Table 3-2	Summary of Gaseous Effluent Pathway Discharge Flow Rates

### SECTION 5.0

Table 5-1	Liquid Effluent Conversion Factors
Table 5-2	Gaseous Effluent Conversion Factors

### SECTION 6.0

Table I.4-2	Summary of Annual and Grazing Season $\chi/Q$ 's and D/Q's for Highest Offsite Sections (from PBNP FSAR, Appendix I)
Table A-1	Bioaccumulation Factors to be Used in the Absence of Site-Specific Data (from Regulatory Guide 1.109, Revision 1)
Table B-1	Dose Factors for Exposure to a Semi-Indefinite Cloud of Noble Gases (from Regulatory Guide 1.109, Revision 1)
Table E-4	Recommended Values for Uap to be Used for the Average Individual in Lieu of Site-Specific Data (from Regulatory Guide 1.109, Revision 1)
Table E-5	Recommended Values for Uap to be Used for the Maximum Exposed Individual in Lieu of Site-Specific Data (from Regulatory Guide 1.109, Revision 1)
Table E-7	Inhalation Dose Factors for Adults (from Regulatory Guide 1.109, Revision 1)
Table E-8	Inhalation Dose Factors for Teenagers (from Regulatory Guide 1.109, Revision 1)
Table E-9	Inhalation Dose Factors for Child (from Regulatory Guide 1.109, Revision 1)
Table E-10	Inhalation Dose Factors for Infant (from Regulatory Guide 1.109, Revision 1)
Table E-11	Ingestion Dose Factors for Adults (from Regulatory Guide 1.109, Revision 1)
Table E-12	Ingestion Dose Factors for Teenager (from Regulatory Guide 1.109, Revision 1)
Table E-13	Ingestion Dose Factors for Child (from Regulatory Guide 1.109, Revision 1)
Table E-14	Ingestion Dose Factors for Infant (from Regulatory Guide 1.109, Revision 1)
Table 1	Infant Ingestion Dose Commitment Factors (NUREG-0172)
Table 2	Child Ingestion Dose Commitment Factors (NUREG-0172)
Table 3	Teen Ingestion Dose Commitment Factors (NUREG-0172)
Table 4	Adult Ingestion Dose Commitment Factors (NUREG-0172)

LIST OF TABLES AND FIGURES

(Continued)

Table 5	Infant Inhalation Dose Commitment Factors (NUREG-0172)
Table 6	Child Inhalation Dose Commitment Factors (NUREG-0172)
Table 7	Teen Inhalation Dose Commitment Factors (NUREG-0172)
Table 8	Adult Inhalation Dose Commitment Factors (NUREG-0172)

## 1.0 OFFSITE DOSE CALCULATION MANUAL ADMINISTRATION

### 1.1 Purpose

The PBNP Offsite Dose Calculation Manual contains the current methodology and parameters for the calculation of offsite doses due to radioactive gaseous and liquid effluents. This manual describes a methodology for demonstrating compliance with 10 CFR 50, Appendix I dose limits. Compliance with Appendix I is demonstrated by periodic calculation of offsite doses based on actual plant releases or by the calculation and comparison of actual plant releases to predetermined release limits. Release limits are those quantities of radioactivity which if released from PBNP will result in the dose limits of Appendix I. Release limits are specified in this manual.

The manual also details the methodology for the determination of gaseous and liquid effluent monitor alarm setpoints. The PBNP Radiation Monitoring System (RMS) effluent monitor alarm setpoints are established to ensure that controlled releases of liquid and gaseous radioactive effluents are maintained as low as is reasonably achievable, to ensure releases result in concentrations to unrestricted areas within limits specified in 10 CFR 20, and to ensure that design objective release limits are not exceeded.

### 1.2 General Responsibilities

The primary responsibility for the implementation of the PBNP offsite dose calculation program and for any actions required

by the program resides with the General Superintendent and the staff of the Nuclear Plant Engineering and Regulation Section (NPERS). NPERS will provide the technical, regulatory, licensing, and administrative support necessary to fulfill the requirements of this manual. The calculation of offsite doses and analysis of data are NPERS responsibilities.

The Manager, PBNP is responsible for assuring that Radiation Monitoring System alarm setpoints are established and maintained in accordance with the methodologies outlined in this manual. The Manager, PBNP is also responsible for assuring the performance of periodic release summaries for the purpose of demonstrating compliance with PBNP effluent release limits.

### 1.3 Manual Revisions

This manual describes the current scope of the PBNP offsite dose calculation program. The program and the manual are maintained by NPERS. Program items or procedures may be periodically updated or changed, either to reflect new parameters or to improve program effectiveness. This manual may be revised at the discretion of NPERS with the concurrence of the PBNP Manager's Supervisory Staff.

## 2.0 RADIATION MONITORING SYSTEM AND RELEASE ACCOUNTING

A computerized Radiation Monitoring System (RMS) is installed at Point Beach Nuclear Plant (PBNP). The RMS includes area, process, and effluent monitors. A description of those monitors used for liquid and gaseous effluents is presented in Tables 2-1 and 2-2. The liquid and gaseous waste processing flow paths, equipment, and monitoring systems are depicted in Figures 2-1 and 2-2. Calibration of the RMS detectors is accomplished in accordance with procedures contained in the PBNP Health Physics Calibration Manual.

The RMS is designed to detect and measure liquid and gaseous releases from the plant effluent pathways. The RMS will initiate isolation and control functions on certain effluent streams. Complete monitoring and accounting of nuclides released in liquid and gaseous effluents is accomplished with the RMS together with the characterization of nuclide distributions by laboratory analysis of grab samples. Sampling frequencies and analysis requirements are described in Tables 15.7.6-1 and 15.7.6-2 of the PBNP Technical Specifications. The various aspects of grab sampling and release accountability are described in the PBNP Release Accountability Manual.

TABLE 2-1  
RADIOACTIVE LIQUID WASTE EFFLUENT MONITORS

<u>Channel Number</u>	<u>Name</u>	<u>Control Function</u>	<u>Detector Type</u>
1(2)RE-216	Containment Fan Coolers Liquid Monitors	None	Scintillation
RE-218	Waste Disposal System Liquid Monitor	Shuts waste liquid overboard	Scintillation
1(2)RE-219	Steam Generator Blowdown Liquid Monitors	Shuts steam generator blowdown isolation valves, blowdown tank outlet valves and steam generator sample valves	Scintillation
RE-220	Spent Fuel Pool Liquid Monitor	None	Scintillation
RE-223	Waste Distillate Overboard Liquid Monitor	Shuts waste distillate overboard isolation valve	Scintillation
1(2)RE-229	Service Water Discharge Monitors	None	Scintillation
RE-230	Retention Pond Discharge Liquid Monitor	None	Scintillation
1(2)RE-222	Steam Generator Blowdown Tank Outlet Monitor	Shuts steam generator blowdown isolation valves and blowdown tank outlet valves	GM Tube



TABLE 2-2  
RADIOACTIVE GASEOUS WASTE EFFLUENT MONITORS

<u>Channel Number</u>	<u>Name</u>	<u>Control Function</u>	<u>Detector Type</u>
1(2)RE-212	Containment Noble Gas Monitor	Actuates containment ventilation isolation	Scintillation
RE-214	Auxiliary Building Exhaust Ventilation Noble Gas Monitor	Shuts gas release valve and shifts auxiliary building exhaust through carbon filters	Scintillation
1(2)RE-215	Condenser Air Ejector Noble Gas Monitors	None	Scintillation
RE-225	Combined Air Ejector Low-Range Noble Gas Monitor	None	Scintillation
RE-221	Drumming Area Vent Noble Gas Monitor	None	Scintillation
RE-224	Gas Stripper Building Exhaust Noble Gas Monitor	None	Scintillation
1(2)RE-305	Unit 1 and 2 Purge Exhaust Noble Gas Monitors (Channel 5 on SPING Units No. 21 and No. 22)	Containment ventilation isolation	Scintillation
RE-315	Auxiliary Building Exhaust Ventilation Noble Gas Monitor (Channel 5 on SPING Unit No. 23)	None	Scintillation
RE-325	Drumming Area Ventilation Noble Gas Monitor (Channel 5 on SPING Unit No. 24)	None	Scintillation

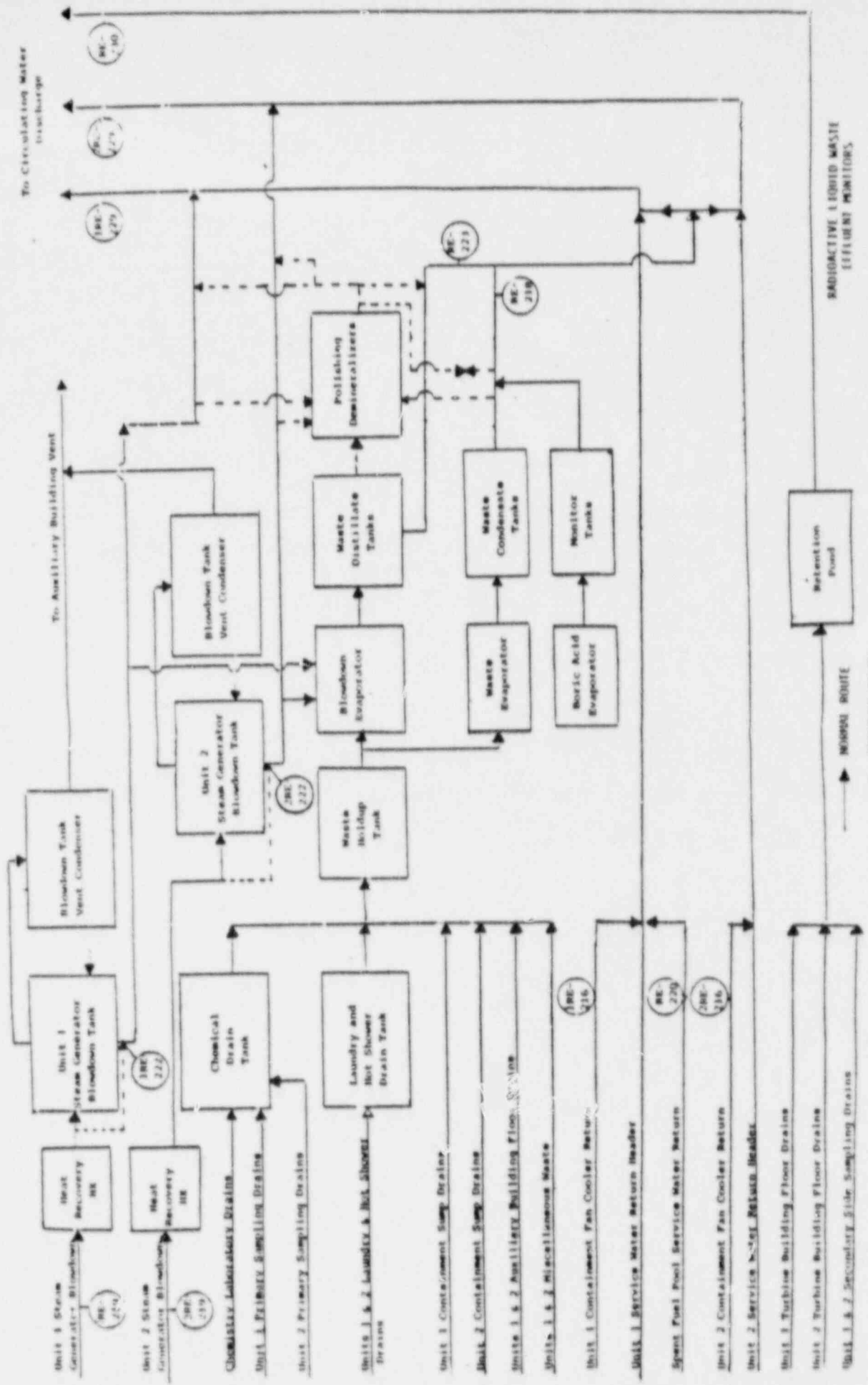

RADIOACTIVE & LIQUID WASTE EFFLUENT MONITORS

→ NORMAL ROUTE  
- - - - - OPTIONAL ROUTE

Figure 2-1

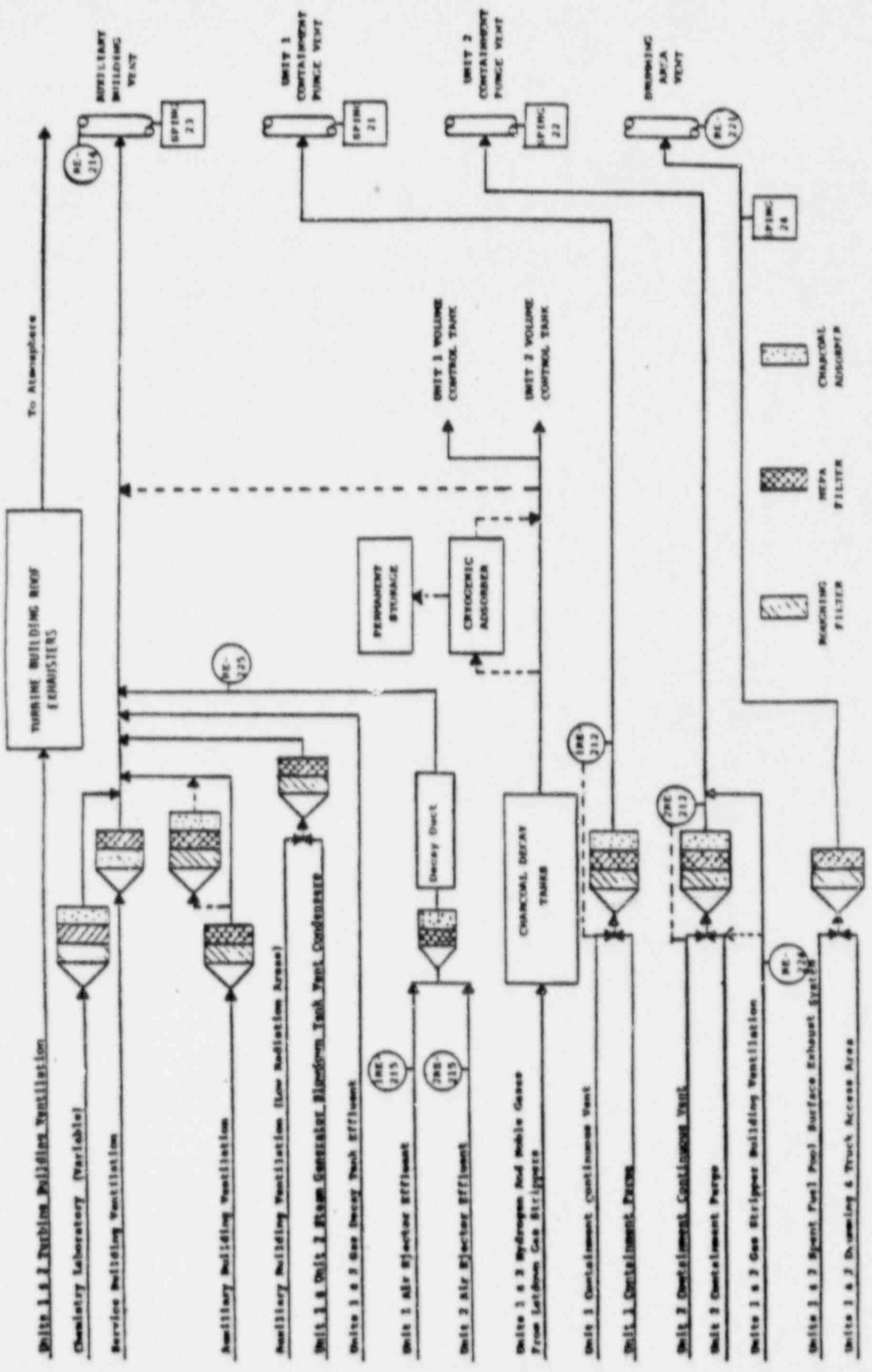

RADIOACTIVE GASEOUS WASTE EFFLUENT HANDLING

Figure 2-2

## 3.0 METHODOLOGY FOR DETERMINING ALARM SETPOINTS

### 3.1 Introduction

The selection and maintenance of alert and alarm setpoints for each effluent monitor of the PBNP radiation monitoring system will be accomplished within the guidelines of this section. The computerized PBNP radiation monitoring system permits each effluent radiation monitor to be programmed to alarm at two distinct setpoints. The alert setpoint is intended to delineate a changing plant condition which may warrant corrective action. The high alarm or trip setpoint will actuate a control function as applicable or require corrective action.

### 3.2 Objective

The effluent monitor setpoints are established to ensure that controlled releases of liquid and gaseous radioactive effluents are maintained as low as is reasonably achievable, to ensure releases result in concentrations to unrestricted areas within limits specified in 10 CFR 20, and to ensure that design objective releases are not exceeded.

### 3.3 Alert Setpoint Guidelines

The alert setpoint of each effluent monitor will generally be set to alarm at two times the established steady-state reading. The alert setpoint is normally set at concentrations well below the alarm setpoint value and is never to be set in excess of the alarm setpoint. In the course of plant operations, certain situations may require a deviation from the two times steady-state guideline.

The intent of the alert setpoint is to warn of changing plant conditions which may warrant an evaluation of the cause of the increased radiation. If the increased reading is actually due to an increased radiation inventory within the system being monitored, as opposed to an increased background radiation field in the vicinity of the detector, an evaluation should be made to determine the impact of the release. The alert setpoint may be adjusted with the approval of the Duty Shift Superintendent. Alert setpoint adjustments are to be made in accordance with the PBNP RMS Alarm Setpoint and Response Book.

#### 3.4 Alarm or Trip Setpoint Guidelines

In accordance with the requirements of Technical Specification 15.7.5.A-2 and 15.7.5.C-2, the alarm or trip setpoint for effluent monitors shall be established to annunciate at radiation levels which would result in unrestricted area concentrations equal to or less than the applicable maximum permissible concentrations contained in 10 CFR 20, Appendix B, Table II. The appropriate detailed response to an effluent alarm is described in the PBNP RMS Alarm Setpoint and Response Book.

#### 3.5 Monitor Calibration and Calibration Constant Determination

Calibration of the RMS effluent detectors is accomplished in accordance with procedures contained in the PBNP Health Physics Calibration Manual. Each detector is exposed to a calibration source with isotopic distribution and intensity characteristics similar to effluents normally released via the applicable pathway. The detector response to the calibration source is normalized to a reference isotope.

The liquid effluent monitors apply the derived calibration constant to standardize all liquid releases to equivalent concentrations of Co-60. The calibration constants are normalized to permit each monitor channel to display effluent concentrations in equivalent concentrations of the Co-60 reference isotope. Calibration constants are normalized to Co-60 based on dose conversion factors contained in Regulatory Guide 1.109, Revision 1, October 1977.

Noble gas effluent monitors apply the calibration constant to standardize all gaseous releases to equivalent concentrations of Xe-133. The calibration constants are normalized to permit each monitor channel to display gaseous effluent concentrations in equivalent concentrations of the Xe-133 reference isotope. Calibration constants are normalized to Xe-133 based on dose conversion factors contained in Regulatory Guide 1.109, Revision 1, October 1977.

Calibration constants are derived from the following formulae:

$$\text{Cal. Constant} = \frac{1}{\text{Sensitivity}}$$

and

$$\text{Sensitivity} = \frac{\text{Monitor Response}}{\sum (\mu\text{Ci/cc}_i) (DF_i/DF_j)}$$

where:

Cal. Constant = a derived calibration constant normalized to standard isotope ( $\mu\text{Ci/cc/cpm}$ ); represents equivalent concentration per monitor response,

Sensitivity = monitor sensitivity normalized to standard isotope ( $\text{cpm}/\mu\text{Ci/cc}$ ),

Monitor response = the counts per minute registered by monitor when exposed to calibration source ( $\text{cpm}$ ),

- $\mu\text{Ci/cc}_i$  = concentration of isotope  $i$  in calibration source,
- $\text{DF}_i$  = dose conversion factor for isotope  $i$  as given in Regulatory Guide 1.109, Revision 1, October 1977,
- $\text{DF}_j$  = dose conversion factor for reference isotope  $j$  as given in Regulatory Guide 1.109, Revision 1, October 1977 and,
- $\frac{\text{DF}_i}{\text{DF}_j}$  = factor for converting actual concentrations to equivalent concentrations. Table 5-1 lists dose conversion factors for common isotopes in liquid releases, and Table 5-2 lists the conversion factors for common isotopes in gaseous releases.

The QAD computer program may be utilized to predict or determine monitor calibration constants. Application of the QAD program may be appropriate for determining monitor response for accident source terms or other instances when the use of a calibration source is impracticable.

### 3.6 Determination of Liquid Effluent Monitor Alarm Setpoint

The alarm setpoint for each monitor will be correlated to the unrestricted area maximum permissible concentration (MPC) of the reference isotope to which the monitor calibration constant was normalized. The liquid monitors referenced to Co-60 equivalent concentrations will have alarm setpoints correlated to the unrestricted area MPC value for Co-60.

Setpoints shall be determined as follows:

$$\text{SP} = \text{MPC} \times \frac{\text{Dilution Water Flow Rate}}{\text{Waste Discharge Flow Rate}}$$

where:

SP = RMS alarm setpoint in equivalent concentrations of Co-60 ( $\mu\text{Ci/cc}$ )

MPC = unrestricted area MPC for Co-60 from 10 CFR 20 Appendix D Table II.

Dilution Water Flow Rate = dilution from circulating water discharge pumps (gpm)

Waste Discharge Flow Rate = maximum liquid effluent flow rate from waste pathway into circulating water (gpm).

Dilution water flow rates are as follows:

- a) Dilution from one recirculation pump = 213,600 gpm
- b) Dilution from two recirculation pumps = 356,000 gpm

Maximum waste discharge flow rates and monitors associated with each liquid effluent pathway are described in Table 3-1.

Alarm setpoints are to be normally established based upon maximum waste discharge flow rates and minimum circulation water flow rates. The alarm setpoints may be adjusted during periods of batch releases, when actual flow rates are known. Alarm setpoint adjustments are to be accomplished in accordance with the provisions and methodologies of this section and require approval of the Manager's Supervisory Staff.

### 3.7 Determination of Gaseous Effluent Monitor Alarm Setpoints

The alarm setpoint for each monitor will be correlated to the unrestricted area maximum permissible concentration (MPC) of the reference isotope to which the monitor calibration constant was normalized. The noble gas effluent monitors will have alarm setpoints correlated to the unrestricted area MPC value for Xe-133.

Setpoints shall be determined as follows:

$$SP = \frac{MPC}{(X/Q) \text{ (Waste Discharge Flow Rate)}}$$

where:

SP = RMS alarm setpoint in equivalent concentration of Xe-133 ( $\mu\text{Ci/cc}$ )



MPC = unrestricted area MPC for Xe-133 from 10 CFR 20 Appendix B Table II.

$\chi/Q$  = highest average annual  $\chi/Q$  value at unrestricted area of  $1.5E-06 \text{ sec/m}^3$

Waste Discharge Flow Rate = flow rate of effluent pathway being monitored.

Gaseous effluent pathway discharge flow rates and monitors associated with each pathway are summarized in Table 3-2.

Alarm setpoints are to be normally established based upon maximum waste discharge flow rates and the average annual  $\chi/Q$  value. The alarm setpoints may be adjusted for release periods if actual flow rates are reduced to less than maximum or actual  $\chi/Q$  values are calculated. Alarm setpoint adjustments are to be made in accordance with the provisions and methodologies of this section and require Manager's Supervisory Staff approval.

TABLE 3-1  
SUMMARY OF LIQUID DILUTION AND EFFLUENT PATHWAY FLOW RATES

<u>Liquid Effluent Pathway</u>	<u>Discharge Flow Rate (gpm)</u>	<u>Monitor(s) in Effluent Pathway</u>
a. Recirculation Water		none
1) 1 recirc. pump	213,000	
2) 2 recirc. pumps	356,000	
b. Service Water Return		1(2)RE-229
1) Flow rate per pump	6,600	
2) Max. 4 pumps		
c. Steam Generator Blowdown		1(2)RE-219 and
1) Max. flow rate from each generator	50	1(2)RE-222
d. Retention Pond		
1) Max. Flow Rate	1,670	RE-230
e. Spent Fuel Pool		
1) Max. Flow Rate	700	RE-220
f. Waste Distillate & Condensate Tank Discharge		RE-218 & RE-223
1) Max. Flow Rate	100	
g. Containment Fan Cooler Return		
1) Max. Flow Rate per Containment	4,000	1(2)RE-216

TABLE 3-2  
SUMMARY OF GASEOUS EFFLUENT PATHWAY DISCHARGE FLOW RATES

<u>Gaseous Effluent Pathway</u>	<u>Monitor(s) Discharge Flow Rate (CFM)</u>	<u>in Effluent Pathway</u>
a. Auxiliary Building Vent	61,400	RE-214 & SPING 23
b. Combined Air Ejector	20	RE-225
c. Unit Air Ejector	10	1(2) RE-215
d. Containment Purge Vent		
1) 1 Fan operating	12,500	1(2)RE-212 & SPINGS 21 & 22
2) 2 Fans operating	25,000	
e. Gas Stripper Building	13,000	RE-224
f. Drumming Area Vent	43,100	RE-221 & SPING 24

#### 4.0 DEMONSTRATING COMPLIANCE WITH 10 CFR 50, APPENDIX I

##### 4.1 Introduction

Maintaining effluents within the dose objectives of Appendix I is demonstrated at PBNP by periodic calculations. Compliance with Appendix I limits is demonstrated by using either of the following methods:

- A. A summation of all releases in equivalent curies may be performed on a quarterly basis. These sums are compared with previously calculated release limits, i.e., quantities which would result in the dose limits of Appendix I to 10 CFR 50. If the equivalent curies released during the calendar quarter are less than or equal to 1/4 of the annual equivalent curie release limits, then de facto compliance with Appendix I exists and no further action is required.
- B. Dose calculations may be performed on a quarterly basis. These calculations may be performed in either of two ways.
  1. Hand Calculations - Based on the meteorology, plant parameters, and dose pathways given in Appendix I of the PBNP FSAR and on the dose conversion factors set forth in Regulatory Guide 1.109 or in NUREG-0172. Section 6.0 of this manual describes dose calculation methodologies.
  2. Computer - This capability will be provided upon completion of the new meteorology and dose assessment software to be installed on the new plant process computer late in 1987.

If release or dose calculations exceed the corresponding quarterly limit during any calendar quarter, a summary of radioactive efflu-

ent releases or dose calculations shall be made monthly until it is determined that release quantities are within the annual limits. If the quarterly calculations exceed twice the corresponding quarterly limit, it is mandatory to calculate doses in accordance with Section 6.0 of this manual.

#### 4.2 Dose Limits

To define the limits and conditions for the controlled release of radioactive materials in liquid and gaseous effluents to the environment, to ensure that these releases are as low as is reasonably achievable in conformance with 10 CFR Parts 50.34a and 50.36a, to ensure that these releases result in concentrations of radioactive materials in liquid and gaseous effluents released to unrestricted areas that are within the limits specified in 10 CFR 20, and to ensure that the releases of radioactive material above background to unrestricted areas are as low as is reasonably achievable, the following design release limits as defined in Appendix I to 10 CFR 50 apply:

- A. The annual total quantity of all radioactive material above background that may be released from each light-water-cooled nuclear power reactor to unrestricted areas should not result in an annual dose or dose commitment from liquid effluents for any individual in an unrestricted area from all pathways of exposure in excess of 3 millirems to the total body or 10 millirems to any organ.
- B. The annual total quantity of all radioactive material above background that may be released from each light-water-cooled nuclear power reactor to the atmosphere should not result in an

annual air dose from gaseous effluents at any location near ground level which could be occupied by individuals in unrestricted areas in excess of 10 millirads for gamma radiation or 20 millirads for beta radiation, or that this quantity should not result in an annual external dose from gaseous effluents to any individual in unrestricted areas in excess of 5 millirems to the total body or 15 millirems to the skin.

- C. The annual total quantity of all radioactive iodine and radioactive material in particulate form above background that may be released from each light-water-cooled nuclear power reactor in effluents to the atmosphere should not result in an annual dose or dose commitment from such radioactive iodine and radioactive material in particulate form for any individual in an unrestricted area from all pathways of exposure in excess of 15 millirems to any organ.

#### 4.3 Release Limits

The design releases limits are derived from the dose evaluation performed in accordance with Appendix I to 10 CFR 50. In the evaluation, certain maximum calculated doses to an organ or the total body of an individual result from the calculated effluent releases. Design release limits are defined by scaling calculated releases upward to the point at which corresponding doses reach the applicable limit specified in Appendix I to 10 CFR 50.

Design release limits are calculated in terms of "equivalent curies" to allow for minor shifts in the radionuclide distribution within an effluent release group. An equivalent curie is obtained

by scaling a radionuclide's activity to an appropriate single radionuclide within each release group by the ratio of their dose factors. Dose factors used in the calculation of equivalent curies are selected for the age group in which the dose limit is most closely approached. From the Appendix I evaluation, it is observed that, except for noble gases, ingestion is generally the most significant dose pathway for both effluents released to the atmosphere and for liquid effluents; hence, ingestion dose factors are used in evaluating effluent releases except when noted otherwise. Conservatively, no credit is given for radioactive decay; and, in one case, the highest dose factor listed for each radionuclide within the applicable age group is used for calculating equivalent curies. For each effluent category, the release limit is calculated as follows:

$$\Sigma DCE_{ijk} = \frac{\Sigma ACE_{ijk} \times L_k \times 2}{D_k}$$

- where  $\Sigma DCE_{ijk}$  = Dose release limit in total equivalent curies for all radionuclides of effluent type k,
- $\Sigma ACE_{ijk}$  = Calculated release in total equivalent curies for all radionuclides of effluent type k,
- $L_k$  = Dose limit per reactor from Appendix I of 10 CFR 50,
- 2 = Two units per plant.
- $D_k$  = Calculated dose resulting from release of  $\Sigma ACE_{ijk}$  curies.

A. The following notes apply to the calculation of design release limits for gaseous effluents:

1. For noble gases, the total body gamma dose is limiting,

2. For radioiodines, the thyroid dose to the infant is limiting; the thyroid dose contribution from other isotopes is negligible,
3. For remaining isotopes, the liver dose to the child is limiting.

B. The following notes apply to the calculation of design release limits for liquid effluents:

1. For radioiodines, the adult total body dose is limiting.
2. For tritium and particulates, the total body dose to an adult is limiting.

Design release limits calculated in the manner described above are quantities of radioactivity in effluents which, for the particular environmental parameters and conditions at Point Beach Nuclear Plant, would result in maximum doses to an individual corresponding to the limits set forth in Appendix I to 10 CFR 50. Actual plant releases are expected to be well within the design release quantities. The periodic review required by this section ensures that plant releases remain as low as is reasonably achievable.

#### 4.4 EPA Regulations

Compliance with the provisions of Appendix I to 10 CFR 50 is adequate demonstration of conformance to the standards set forth in 40 CFR 190 regarding the dose commitment to individuals from the uranium fuel cycle. If release or dose calculations exceed twice the annual limits, dose calculations shall be performed as described in Section



6.0 of this manual and shall include exposures from effluent pathways and direct radiation contributions from the reactor units and from any outside storage tanks.

## 5.0 CALCULATION AND COMPARISON OF EFFLUENT RELEASES TO RELEASE LIMITS

Technical Specifications 15.7.5.B.3 and 15.7.5.D.3 require that an effluent release summary or dose calculation be performed quarterly. This section describes the methodology for the calculation and comparison of equivalent curie releases to equivalent curie release limits.

### 5.1 Definitions

$$CE_{ij} = C_i \times \frac{DF_i}{DF_j}$$

$CE_{ij}$  = Activity of radionuclide i expressed in terms of an equivalent number of curies of radionuclide j.

$C_i$  = Actual number of curies of radionuclide i.

$DF_i$  = Dose factor for radionuclide i as given in Regulatory Guide 1.109, Revision 1, October 1977.

$DF_j$  = Dose factor for reference radionuclide j as given in Regulatory Guide 1.109, Revision 1, October 1977.

$\frac{DF_i}{DF_j}$  = Factor for converting actual curies to equivalent curies. Table 5-1 lists conversion factors for common radionuclides in liquid releases, and Table 5-2 lists the conversion factors for common radionuclides in gaseous releases.

### 5.2 Calculation of Liquid Effluent Releases

The annual design release limits for liquid effluents are as follows:

A. Tritium:  $C_i \leq 1.96E+04$  curies

B. Radioiodines:  $\sum CE_{ij} \leq 2.62E+01$  I-131 equivalent curies

Where 1. The reference isotope, j, is I-131.

2.  $DF_i$  is the adult total body dose factor for isotope i given in Table E-11 of Regulatory Guide 1.109, Revision 1, October 1977 or Table 5-1.

3.  $DF_j$  is the adult total body dose factor for the reference isotope, I-131, as given in Table E-11 of Regulatory Guide 1.109, Revision 1, October 1977.

C. Others (isotopes other than tritium, noble gases, or radioiodines):

$\sum CE_{ij} \leq 9.47E+01$  Co-60 equivalent curies

Where 1. The reference radionuclide, j, is Co-60.

2.  $DF_i$  is the adult total body dose factor for radionuclide  $i$  in Table E-11 of Regulatory Guide 1.109, Revision 1, October 1977, or Table 5-1.
3.  $DF_i$  is the adult total body dose factor for the reference radionuclide Co-60 in Table E-11 of Regulatory Guide 1.109, Revision 1, October 1977.

D. Noble gases released in liquid effluents are to be included with noble gases released in gaseous effluents.

Quarterly limits are defined as 1/4 of the annual limits.

### 5.3 Calculation of Gaseous Effluent Releases

The annual design release limits for gaseous effluents are as follows:

- A. Tritium:  $C_i \leq 2.90E+04$  curies
- B. Noble Gases:  $\sum CE_{ij} \leq 1.04E+06$  Xe-133 equivalent curies
  - Where 1. The reference radionuclide  $j$ , is Xe-133.
  2.  $DF_i$  is the dose factor for radionuclide  $i$  given as  $DFB_i$  in Table B-1 of Regulatory Guide 1.109, Revision 1, October 1977.
  3.  $DF_i$  is the dose factor for the reference radionuclide Xe-133 given under  $DFB_i$  in Table B-1 of Regulatory Guide 1.109, Revision 1, October 1977.
- C. Radioiodines:  $\sum CE_{ij} \leq 3.52E-01$  I-131 equivalent curies
  - Where 1. The reference isotope,  $j$ , is I-131.
  2.  $DF_i$  is the infant thyroid dose factor for isotope  $i$  given in Table E-14 of Regulatory Guide 1.109, Revision 1, October 1977, or Table 5-2.
  3.  $DF_i$  is the infant thyroid dose factor for the reference isotope I-131 as given in Table E-14 of Regulatory Guide 1.109, Revision 1, October 1977.
- D. Particulates (isotopes other than tritium, noble gases or radioiodines):
 
$$\sum CE_{ij} \leq 1.72E+00 \text{ Co-60 equivalent curies}$$

Where 1. The reference radionuclide j, is Co-60.

2.  $DF_i$  is the highest dose factor for radionuclide i in any column of Table E-13 of Regulatory Guide 1.109, Revision 1, October 1977, or Table 5-2.

3.  $DF_j$  is the highest dose factor for the reference radionuclide, Co-60, given in any column of Table E-13 of Regulatory Guide 1.109, Revision 1, October 1977.

Quarterly limits are defined as 1/4 of the annual limits.

#### 5.4 Tritium in Liquid and Gaseous Effluents

The design release limit for tritium in liquid effluents may be increased, provided it is accompanied by a proportional decrease in the design release limit for tritium in gaseous effluents. Similarly, the design release limit for tritium in gaseous effluents may be increased, provided it is accompanied by a proportional decrease in the design release limit for tritium in liquid effluents. The tritium adjustment will be made in accordance with the following formula:

$$\frac{\text{Annual Liq. H-3 Release}}{\text{Annual Liq. H-3 Release Limit}} + \frac{\text{Annual Gaseous H-3 Release}}{\text{Annual Gaseous H-3 Release Limit}} \leq 2.0$$

#### 5.5 Quarterly Summary

Effluent release summaries are made in accordance with this section. Either release summaries or dose calculations are to be accomplished quarterly. In the event that actual quantities of radioactive materials released in liquid and gaseous effluents for any quarter exceed twice the quarterly limit as described in this section, actual doses must be calculated in accordance with Section 6.0 and a special report shall be prepared and submitted to the NRC.

TABLE 5-1  
LIQUID EFFLUENT CONVERSION FACTORS

- A. Tritium: The conversion factor is unity because tritium is considered by itself.
- B. Noble Gases: The noble gases released in liquid effluents are to be added to noble gases released in gaseous effluents. They are normally insignificant.
- C. Radioiodine: For iodines, use Regulatory Guide 1.109 Revision 1, Table E-11, total body dose factors for an adult. Reference isotope ( $DF_j$ ) is I-131.

ISOTOPE	$DF_i$ (mrem/pCi)	$DF_i/DF_j$
I-130	8.80E-07	2.58E-01
I-131	3.41E-06	1.00E+00
I-132	1.90E-07	5.57E-02
I-133	7.53E-07	2.21E-01
I-134	1.03E-07	3.02E-02
I-135	4.28E-07	1.26E-01

- D. Other: For non-iodine and non-tritium in liquids, use Regulatory Guide 1.109 Revision 1, Table E-11, adult total body dose factors. Although the teen liver receives the highest organ dose, the adult total body dose is limiting because fewer real Curies are required to yield the 6 mrem whole body dose limit than the 20 mrem organ dose limit as determined from calculations based on Appendix I analysis as given in the PBNP FSAR. Radionuclides are normalized to Co-60.

ISOTOPE	$DF_i$ (mrem/pCi)	$DF_i/DF_j$	ISOTOPE	$DF_i$ (mrem/pCi)	$DF_i/DF_j$
F-18	6.92E-08	1.47E-02	Ru-106	3.48E-07	7.37E-02
Na-22	1.74E-05	3.69E+00	Rh-103m	(included in Ru-103)	
Na-24	1.70E-06	3.60E-01	Rh-105	5.83E-08	1.24E-02
Cl-38	8.65E-08	1.83E-02	Rh-106	(included in Ru-106)	
Sc-46	3.11E-09	6.59E-04	Cd-109	8.81E-09	1.87E-03
Cr-51	2.66E-09	5.64E-04	Ag-110m	8.79E-08	1.86E-02
Mn-54	8.72E-07	1.85E-01	Sn-113	9.45E-08	2.00E-02
Mn-56	2.04E-08	4.32E-03	Sb-122	7.40E-07	1.57E-01
Fe-55	4.43E-07	9.39E-02	Sb-124	1.11E-06	2.35E-01
Fe-59	3.91E-06	8.28E-01	Sb-125	4.26E-07	9.03E-02
Co-56	1.67E-06	3.54E-01	Te-125m	3.59E-07	7.61E-02
Co-57	2.91E-07	6.17E-02	Te-127m	8.25E-07	1.75E-01
Co-58	1.67E-06	3.54E-01	Te-127	2.38E-08	5.04E-03

Table 5-1 (Continued)

ISOTOPE	$DF_i$ (mrem/pCi)	$DF_i/DF_j$	ISOTOPE	$DF_i$ (mrem/pCi)	$DF_i/DF_j$
Co-60	4.72E-06	1.00E+00	Te-129m	1.82E-06	3.86E-01
Zn-65	6.96E-06	1.47E+00	Te-129	7.65E-09	1.62E-03
Cu-64	3.91E-08	8.28E-03	Te-131m	7.05E-07	1.49E-01
Zn-69m	3.73E-08	7.90E-03	Te-131	6.22E-09	1.32E-03
As-76	1.11E-06	2.35E-01	Te-132	1.53E-06	3.24E-01
Se-75	4.39E-07	9.30E-02	Cs-134m	2.29E-08	4.85E-03
Br-83	4.02E-08	8.51E-03	Cs-134	1.21E-04	2.56E+01
Br-84	5.21E-08	1.10E-02	Cs-136	1.85E-05	3.92E+00
Br-85	2.14E-09	4.53E-04	Cs-137	7.14E-05	1.51E+01
Rb-86	9.83E-06	2.08E+00	Cs-138	5.40E-08	1.14E-02
Rb-88	3.21E-08	6.80E-03	Ba-133	4.43E-07	9.39E-02
Rb-89	2.82E-08	5.97E-03	Ba-139	2.84E-09	6.02E-04
Sr-85m	7.97E-08	1.69E-02	Ba-140	1.30E-06	2.82E-01
Sr-85	5.58E-06	1.18E+00	Ba-141	1.59E-09	3.37E-04
Sr-89	8.84E-06	1.87E+00	La-140	3.33E-10	7.06E-05
Sr-90	1.86E-03	3.94E+02	La-142	1.45E-11	3.07E-06
Sr-91	2.29E-07	4.85E-02	Ce-139	1.05E-09	2.22E-04
Sr-92	9.30E-08	1.97E-02	Ce-141	7.18E-10	1.52E-04
Y-88	1.29E-10	2.73E-05	Ce-143	1.35E-10	2.86E-05
Y-90	2.58E-10	5.47E-05	Ce-144	2.62E-08	5.55E-03
Y-91m	3.52E-12	7.46E-07	Pr-143	4.56E-10	9.66E-05
Y-91	3.77E-09	7.99E-04	Pr-144	1.53E-12	3.24E-07
Y-92	2.47E-11	5.23E-06	Nd-147	4.35E-10	9.22E-05
Y-93	7.40E-11	1.57E-05	Eu-152	3.90E-08	8.26E-03
Zr-95	6.60E-09	1.40E-03	Ta-182	4.65E-09	9.85E-04
Zr-97	1.55E-10	3.28E-05	W-187	3.01E-08	6.38E-03
Nb-94	3.72E-09	7.88E-04	Au-198	9.08E-09	1.92E-02
Nb-95	1.86E-09	3.94E-04	Hg-203	6.52E-09	1.38E-03
Nb-97	4.82E-12	1.02E-06	Bi-207	2.64E-08	5.59E-03
Mo-90	2.46E-07	5.21E-02	Np-239	6.45E-11	1.37E-05
Mo-99	8.20E-07	1.74E-01	U-235	4.86E-05	1.03E+01
Tc-99m	8.89E-09	1.88E-03	U-238	4.54E-05	9.62E+00
Tc-101	3.59E-09	7.61E-04	Am-241	5.41E-05	1.15E+01
Ru-103	7.97E-08	1.69E-02			
Ru-105	6.08E-09	1.29E-03			

E. Additional Isotopes - To obtain dose factors for isotopes not in this table, consult Regulatory Guide 1.109 Revision 1 or NUREG-0172. For  $DF_i$  of isotopes not listed in either Regulatory Guide 1.109, Revision 1, or NUREG-0172,  $DF_i$  values may be calculated by scaling to another isotope of the same element by the ratio of MPCs (10 CFR 20, Table II, Col. 2). If the MPC is not available, use the ALI from ICRP-30. If there is no DF for any isotope of an element, use the DF of an isotope of an element in the same chemical family, i.e. Au and Ag, whose ALI is similar. Then scale by ratio of ALIs.

TABLE 5-2  
GASEOUS EFFLUENT CONVERSION FACTORS

- A. Tritium: The conversion factor is unity because tritium is considered by itself.
- B. Noble Gases: Use gamma-body dose factors,  $DFB_i$ , from Table B-1 of Regulatory Guide 1.109, Revision 1. Normalize to Xe-133:

<u>ISOTOPE</u>	<u><math>DFB_i</math></u>	<u><math>DFB_i/DFB_j</math></u>
Ar-41	8.84E-03	3.01E+01
Kr-83m	7.56E-08	2.57E-04
Kr-85m	1.17E-03	3.98E+00
Kr-85	1.61E-05	5.48E-02
Kr-87	5.92E-03	2.01E+01
Kr-88	1.47E-02	5.00E+01
Kr-89	1.66E-02	5.65E+01
Kr-90	1.56E-02	5.31E+01
Xe-131m	9.15E-05	3.11E-01
Xe-133m	2.51E-04	8.54E-01
Xe-133	2.94E-04	1.00E+00
Xe-135m	3.12E-03	1.06E+01
Xe-135	1.81E-03	6.16E+00
Xe-137	1.42E-03	4.83E+00
Xe-138	8.83E-03	3.00E+01

- C. Radioiodine: For iodines in gaseous effluents, use thyroid dose factors for an infant from Table E-14 of Regulatory Guide 1.109, Revision 1. Normalize to I-131.

<u>ISOTOPE</u>	<u><math>DF_i</math></u>	<u><math>DF_i/DF_j</math></u>
I-130	1.48E-03	1.06E-01
I-131	1.39E-02	1.00E+00
I-132	1.58E-04	1.14E-02
I-133	3.31E-03	2.38E-01
I-134	4.15E-05	2.99E-03
I-135	6.49E-04	4.67E-02

D. Other: For particulates in effluents released to the atmosphere, use the ingestion dose factors for a child from Table E-13 of Regulatory Guide 1.109, Revision 1. For isotopes not listed in Table E-13, use NUREG-0172 Table 2. Normalize to Co-60. In using Regulatory Guide 1.109, Revision 1, or NUREG-0172 the table is scanned for the highest  $DF_i$  for any organ.

<u>ISOTOPE</u>	<u><math>DF_i</math></u>	<u><math>DF_i/DF_j</math></u>	<u>ISOTOPE</u>	<u><math>DF_i</math></u>	<u><math>DF_i/DF_j</math></u>
F-18	2.49E-06	8.50E-02	Tc-101	1.91E-08	6.52E-04
Na-22	5.88E-05	2.01E+00	Ru-103	1.89E-05	6.45E-01
Na-24	5.80E-06	1.98E-01	Ru-105	4.21E-05	1.44E+00
Cl-38	3.11E-06	1.06E-01	Ru-106	1.82E-04	6.21E+00
Sc-46	3.95E-05	1.35E+00	Rh-103m	(included in Ru-103)	
Cr-51	4.72E-07	1.61E-02	Rh-105	1.71E-05	5.84E-01
Mn-54	1.07E-05	3.65E-01	Rh-106	(included in Ru-106)	
Mn-56	4.84E-05	1.65E+00	Cd-109	1.20E-05	4.10E-01
Fe-55	1.15E-05	3.92E-01	Ag-110m	4.33E-05	1.48E+00
Fe-59	2.78E-05	9.49E-01	Sn-113	2.75E-05	9.39E-01
Co-56	3.15E-05	1.08E+00	Sb-122	4.63E-05	1.58E+00
Co-57	4.04E-06	1.38E-01	Sb-124	6.94E-05	2.37E+00
Co-58	1.05E-05	3.58E-01	Sb-125	1.71E-05	5.84E-01
Co-60	2.93E-05	1.00E+00	Te-125m	1.14E-05	3.89E-01
Cu-64	1.15E-05	3.92E-01	Te-127m	8.24E-05	2.81E+00
Zn-65	3.65E-05	1.25E+00	Te-127	1.84E-05	6.28E-01
Zn-69m	3.94E-05	1.34E+00	Te-129m	1.43E-04	4.88E+00
Br-83	1.71E-05	5.84E-01	Te-129	8.34E-06	2.85E-01
Br-84	1.98E-07	6.76E-03	Te-131m	1.01E-04	3.45E+00
Br-85	9.12E-04	3.11E-04	Te-131	4.36E-07	1.49E-02
Se-75	1.37E-05	4.68E-01	Te-132	4.50E-05	1.54E+00
As-76	6.94E-05	2.37E+00	Cs-134m	1.58E-07	5.39E-03
Rb-86	6.70E-05	2.29E+00	Cs-134	3.84E-04	1.31E+01
Rb-88	1.90E-07	6.48E-03	Cs-136	6.46E-05	2.20E+00
Rb-89	1.17E-07	3.99E-03	Cs-137	3.27E-04	1.12E+01
Sr-85m	7.29E-07	2.49E-02	Cs-138	3.17E-07	1.08E-02
Sr-85	5.10E-05	1.74E+00	Ba-133	2.77E-05	9.45E-01
Sr-89	1.32E-03	4.51E+01	Ba-139	2.39E-05	8.16E-01
Sr-90	1.70E-02	5.80E+02	Ba-140	8.31E-05	2.84E+00
Sr-91	5.30E-05	1.81E+00	Ba-141	2.00E-07	6.83E-03
Sr-92	1.71E-04	5.84E+00	La-140	9.48E-05	3.24E+00
Y-88	5.85E-05	2.00E+00	La-142	3.31E-05	1.13E+00
Y-90	1.17E-04	3.99E+00	Ce-141	2.47E-05	8.43E-01
Y-91	8.02E-05	2.74E+00	Ce-139	6.80E-04	2.32E-01
Y-91m	7.48E-07	2.55E-02	Ce-143	5.55E-05	1.89E+00
Y-92	1.04E-04	3.55E+00	Ce-144	1.70E-04	5.80E+00
Y-93	1.70E-04	5.80E+00	Pr-143	4.24E-05	1.45E+00
Zr-95	2.66E-05	9.08E-01	Pr-144	8.59E-09	2.93E-03
Zr-97	1.53E-04	5.22E+00	Nd-147	3.58E-05	1.22E+00



TABLE 5-2 (Continued)

<u>ISOTOPE</u>	<u>DF<sub>i</sub></u>	<u>DF<sub>i</sub>/DF<sub>j</sub></u>	<u>ISOTOPE</u>	<u>DF<sub>i</sub></u>	<u>DF<sub>i</sub>/DF<sub>j</sub></u>
Nb-94	3.24E-05	1.11E+00	Eu-152	1.84E-05	6.28E-01
Nb-95	1.62E-05	5.53E-01	Ta-182	4.05E-05	1.38E+00
Nb-97	1.21E-05	4.13E-01	W-187	3.57E-05	1.22E+00
Mo-90	8.52E-06	2.91E-01	Au-198	3.56E-05	1.22E+00
Mo-99	2.84E-05	9.69E-01	Hg-203	8.90E-06	3.04E-01
Tc-99m	1.03E-06	3.51E-02	Bi-207	7.67E-05	2.62E+00
			U-235	3.42E-03	1.17E+02
			U-238	3.27E-03	1.12E+02
			Np-239	2.79E-05	9.52E-01
			Am-241	1.43E-03	4.88E+01

E. Additional Isotopes: To obtain  $DF_i/DF_j$  for isotopes not in this table, use the approach as described in item D, above. For  $DF_i$  of isotopes not listed in either Regulatory Guide 1.109, Revision 1 or NUREG-0172,  $DF_i$  values may be calculated by scaling to another isotope of the same element by the ratio of MPCs (10 CFR 20, Table II, Col. 2). If the MPC is not available, use the ALI from ICRP-36. If there is no DF for any isotope of an element, use the DF of an isotope in the same chemical family, i.e. Cd and Hg, whose ALI is similar. Then scale by ratio of the ALIs.

F. Notes

- (1) For radioiodines in gaseous effluents, ingestion dose factors are used, because the grass-cow-milk pathway is limiting.
- (2) For particulates in gaseous effluents, ingestion dose factors are used, because ingestion was generally the most significant dose pathway. Note also that a significant portion of inhaled particulates is eventually swallowed, thereby further confirming the appropriateness of this approach.

## 6.0 MANUAL CALCULATION OF DOSES RESULTING FROM EFFLUENTS

The methodology for calculating doses resulting from PBNP radioactive effluents is presented in this section. Doses are only required to be calculated if quarterly releases exceed twice the quarterly limit. Compliance with Appendix I dose objectives are demonstrated quarterly by either summarizing releases in accordance with Section 5.0 or calculating doses in accordance with this section.

### 6.1 Basis

There are, of course, a very large number of exposure pathways that can be considered for calculating dose to any offsite individual. However, the actual pathways to be considered for this procedure are limited to those pathways found most significant in the 10 CFR 50 Appendix I evaluation for PBNP as contained in Appendix I of the PBNP FSAR. These are as follows:

#### A. Gaseous Releases

1. Radioiodine dose to an infant thyroid via the cow or goat milk pathway at the site boundary (1300 m) in SSE sector.
2. Noble gas dose:
  - (a) Gamma dose to the whole body at the site boundary (1460 m) in the SSW sector.
  - (b) Beta dose to the skin at the site boundary (1460 m) in the SSW sector.
3. Tritium dose is not normally limiting and should only be calculated if tritium releases are exceptionally high. Calculate adult inhalation dose to the whole body at the site boundary (1460 m) in the SSW sector.
4. Dose from particulates is not normally limiting and should only be calculated if particulate releases are exceptionally

high. Calculate the liver dose to a child at the site boundary (1460 m) in the SSW sector via the stored vegetable pathway as described in Appendix I to the PBNP FSAR.

B. Liquid Effluents

1. Radioiodine dose from liquid effluents is not normally limiting and should only be calculated if radioiodine releases in liquid effluents are exceptionally high. Calculate dose to adult thyroid and whole body from the fish pathway with fish at the edge of the initial mixing zone (dilution factor of 5) and a consumption rate of 21 Kg/year. Further assume 24 hours holdup time before consumption.
2. Noble gases from liquid effluents are normally several orders of magnitude less than those in gaseous effluents. They may be presumed to diffuse into the air and should be added to the noble gases in gaseous effluents.
3. Tritium dose is not normally limiting and should only be calculated if tritium releases are exceptionally high. Calculate adult ingestion dose to the whole body from drinking water at Two Rivers, using a total dilution factor of 100.
4. For other isotopes, the limiting dose is that to the whole body of the adult from eating fish obtained at the edge of the initial mixing zone. The critical organ is the liver of the teenager from eating fish obtained at the edge of the initial mixing zone.

### C. Other Pathways

In the course of the Appendix I evaluation for PBNP, the exposure pathways listed in A. and B., above, were found to be the most significant. Other pathways, however, were also considered. These need not be analyzed, unless the unique circumstances of a particulate release suggest their consideration. A complete description of all pathways is presented in Section 8.0 of Appendix I of the PBNP FSAR. They are:

1. Gaseous: Doses to total body, skin, bone, liver, thyroid, kidney, lung, and GI tract:
  - Inhalation - SSW (1460 m)
  - Deposition on ground - SSW (1460 m)
  - Fresh Vegetables - SSW (1460 m)
  - Stored Vegetables - SSW (1460 m)
  - Cow milk - SSE (1300 m)
  - Goat milk - SSE (1300 m)
  - Direct exposure ( $\beta$ ,  $\gamma$ ) - SSW (1460 m)
  
2. Liquid: Doses to total body, skin, bone, liver, thyroid, kidney, lung, and GI tract:
  - Ingestion of potable water - Two Rivers (12 mi. S)
  - Ingestion of fish - edge of initial mixing zone
  - Ingestion of fresh vegetables - Two Rivers (12 mi. S)
  - Ingestion of stored vegetables - Two Rivers (12 mi. S)
  - Ingestion of cow's milk - Two Rivers (12 mi. S)
  - Ingestion of meat - Two Rivers (12 mi. S)
  - Swimming - edge of initial mixing zone
  - Boating - edge of initial mixing zone
  - Shoreline deposits - (1500 m, S)

### 6.2 Meteorology

Table I.4-2 of Appendix I to the PBNP FSAR is included herewith as a convenient summary of  $\chi/Q$  and  $D/Q$  values. The Drumming Area Vent (DAV) is not shown separately in the table, because its exit velocity is identical with the Auxiliary Building Vent (ABV). Hence, DAV releases are to be included with ABV releases. In fact, there are

other simplifications that can be made. For purposes of this procedure, gaseous releases should be summarized into two categories:

- a. Auxiliary Building Vent (ABV) - Include releases from ABV, gas decay tanks, and drumming area vent (DAV).
- b. Purge Vent - Include releases from continuous purge, intermittent purge, gas stripper building, and turbine building roof exhausters. Thus, in applying this procedure, the  $\chi/Q$ 's and  $D/Q$ 's from only lines IA and IIA of Table I.4-2 are required.

### 6.3 Procedure for Gaseous Effluents

- A. Group all releases into the two categories (IA or IIA) as described above.
- B. Calculate Infant Thyroid Dose:

During growing season (April through September)

1. Perform this section for all iodines for each release type (IA and IIA).
2. Select grazing season  $D/Q$ 's from Table I.4-2. Assume nearest cow is at site boundary at 1300 meters in SSE direction.
3. Use the following:

$$D_{ij} = DK_i \times Q_{ij} \times D/Q_j$$

where:  $D_{ij}$  = dose to thyroid in mrem for iodine  $i$  and release type  $j$ .

$Q_{ij}$  = curies released of iodine  $i$  and release type  $j$ .

$D/Q_j$  = deposition constant in  $m^{-2}$  for release type  $j$ .

$DK_i$  = combined dose conversion constants derived from equations C-5, C-7, C-10, C-11, and C-13 of Regulatory Guide 1.109 in units of  $mrem \cdot m^2$  per Ci:

<u>Isotope</u>	<u>DK<sub>i</sub></u>
I-130	6.96E+06
I-131	8.18E+09
I-132	1.12E+00
I-133	7.64E+07
I-134	6.85E-12
I-135	1.59E+05

4. Sum the results for all iodines and all release types.

Non-grazing season (October through March)

1. Perform this section for all iodines for each release type (IA and IIA).
2. Select annual  $\chi/Q$  values from Table I.4-2. Assume receptor is at site boundary at 1460 meters in SSW direction.
3. Use the following:

$$D_{ij} = DL_i \times Q_{ij} \times \chi/Q_j$$

where:  $D_{ij}$  = dose to thyroid in mrem for iodine  $i$  and release type  $j$ .

$Q_{ij}$  = curies released of iodine  $j$  and release type  $j$ .

$\chi/Q_j$  = annual diffusion factor in  $\text{sec}/\text{m}^3$  for release type  $j$ .

$DL_i$  = combined dose conversion constants derived from equations C-3 and C-4 of Regulatory Guide 1.109 Revision 1 in units of mrem-m<sup>3</sup> per Ci-sec:

<u>Isotope</u>	<u>DL<sub>i</sub></u>
I-130	5.06E+04
I-131	4.70E+05
I-132	5.37E+03
I-133	1.13E+05
I-134	1.41E+03
I-135	2.21E+04

4. Sum the results for all iodines and all release types.
- C. Calculate gamma and beta doses to whole body and skin, respectively, from noble gases:
1. Perform this section for all noble gases for each release type.

2. Select annual  $\chi/Q$  values from Table I.4-2. Assume receptor is at site boundary (1460 m) in SSW sector.
3. Use the following:

$$D_{ij} = 3.17 \times 10^4 \times DN_i \times Q_{ij} \times \chi/Q_j$$

where:  $D_{ij}$  = dose in mrem from noble gas  $i$  in effluent type  $j$ .

$DN_i$  = dose conversion factor in mrem-m<sup>3</sup> per pCi-yr from Table B-1 of Regulatory Guide 1.109 Revision 1 (October 1977). Use  $DFS_i$  for skin dose and  $DFB_i$  for whole body gamma dose.

$Q_{ij}$  = curies released of noble gas  $i$  and release type  $j$ .

$\chi/Q_j$  = diffusion constant in sec/m<sup>3</sup> for release type  $j$ .

$$3.17 \times 10^4 = \text{pCi/Ci divided by sec/yr}$$

4. Sum the beta dose results for all noble gases and all release types.
  5. Sum the whole body gamma dose results for all noble gases and all release types.
  6. Sum the beta and gamma doses to obtain total skin dose.
- D. If tritium calculations appear advisable, calculate adult inhalation dose as follows:

$$D_j = 40.1 \times Q_j \times \chi/Q_j$$

where:  $D_j$  = the tritium dose to an adult in mrem.

$Q_j$  = curies of tritium in release type  $j$ .

$\chi/Q_j$  = diffusion factor in sec/m<sup>3</sup> for release type  $j$ .

40.1 = dose conversion factor for tritium in mrem-m<sup>3</sup> per Ci-sec based on equations C-3 and C-4 in Regulatory Guide 1.109 Revision 1.

- E. Particulates in gaseous releases will not be limiting under any reasonably anticipated conditions. If particulates are suspected

to be high, child inhalation dose to whole body will be calculated. Based on the ratios observed in the Appendix I evaluation for PBNP, the inhalation dose will be multiplied by a factor of 17.9 to obtain an approximate screening criterion for dose to a child's liver via the stored vegetable pathway. If this dose exceeds the limits of 10 CFR 50 Appendix I, a more precise calculation of particulate doses will be performed by the Nuclear Plant Engineering and Regulation Section in accordance with Regulatory Guide 1.109 Revision 1. Child inhalation dose is calculated as follows:

1. Perform this section for all particulates for each release type.
2. Select annual  $\chi/Q$  values from Table I.4-2. Assume receptor is at site boundary (1460 meters) in SSW sect.
3. Use the following:

$$D_{ij} = 1.17 \times 10^8 \times Q_{ij} \times \chi/Q_j \times DF_i$$

where:  $D_{ij}$  = total body inhalation dose in mrem from the particulate i in effluent type j,

$1.17 \times 10^8$  = conversion factor in pCi-m<sup>3</sup> per Ci-sec.

$Q_{ij}$  = curies of particulate i in effluent type j,

$\chi/Q_j$  = diffusion factor in sec/m<sup>3</sup> for release type j,

$DF_i$  = dose factor in mrem/pCi for isotope i from Table E-9 of Regulatory Guide 1.109 Revision 1 or NUREG-0172, Table 6 under total body column.

4. Sum the results for all isotopes and all release types.
5. Multiply by 17.9 to obtain screening dose to child's liver.

#### 6.4 Procedure for Liquid Effluents

- A. Calculate radioiodine dose to the adult whole body and thyroid from eating fish obtained at the edge of the initial mixing



zone (dilution factor = 5). Assume a consumption rate of 21 Kg/yr and a 24-hour holdup time before consumption.

1. Use the following:

$$D_i = \frac{1120 U_a M}{F} Q_i DF_i e^{-\lambda_i t_p}$$

where:  $D_i$  = dose in mrem from isotope  $i$

1120 = factor to convert Ci/yr per ft<sup>3</sup>/sec to pCi/l. It therefore has units of (pCi/Ci) per (l/yr)/(ft<sup>3</sup>/sec)

$U_a$  = consumption rate = 21 Kg/yr

$M$  = mixing ratio = 1/5 (inverse of dilution factor)

$F$  = discharge flow in ft<sup>3</sup>/sec. Average for PBNP = 644.

$Q_i$  = curies of isotope  $i$  released during period.

$B_i$  = bioaccumulation factor for freshwater fish = 15 (Table A-1 of Regulatory Guide 1.109 Revision 1)

$DF_i$  = dose conversion factor from Table E-11 of Regulatory Guide 1.109 Revision 1 in mrem/pCi ingested for adult thyroid or whole body as applicable.

$\lambda_i$  = decay constant for isotope  $i$  in hr<sup>-1</sup>.

$t_p$  = holdup time = 24 hours.

2. The equation then simplifies to:

$$D_i = 1.1E+02 Q_i DF_i e^{-\lambda_i t_p}$$

3. The exponential term may be ignored for all isotopes with half lives longer than two days.
4. Sum the results for all radioiodines.
5. Radioiodine decay constants, half-lives, and dose factors are listed below:

ISOTOPE	T( $\frac{1}{2}$ )	$\lambda(\text{hr}^{-1})$	DF	DF
			adult thyroid -ingestion	adult whole body - ingestion
I-130	12.36h	5.61E-02	1.89E-04	8.80E-07
I-131	8.04d	3.59E-03	1.95E-03	3.41E-06
I-132	2.30h	3.01E-01	1.90E-05	1.90E-07
I-133	20.8 h	3.33E-02	3.63E-04	7.53E-07
I-134	52.6 m	7.91E-01	4.99E-06	1.03E-07
I-135	6.61h	1.05E-01	7.65E-05	4.28E-07

Half-life values are from ICRP Publication 30, Supplements to Parts 1, 2, 3.

B. Noble gas releases in liquid effluents are usually several orders of magnitude less than those in gaseous effluents.

They may be presumed to diffuse into the air and should be added to the noble gases in gaseous effluents in release type IIA (ground level release).

C. Tritium dose is not normally limiting and usually need not be calculated. If tritium releases are exceptionally high, calculate the average adult ingestion dose to whole body from drinking water at Two Rivers, with a dilution factor of 100.

1. The equation is similar to that for radioiodines in A.1, above, except that the bioaccumulation factor ( $B_1$ ) = 1.
2. With the following values for the constants,  $M = 0.01$ ; a consumption rate,  $U_a$ , of 350 l/yr; and a dose conversion factor,  $DF_1$ , of  $1.05E-07$  mrem/pCi, formula A.1 simplifies to:

$$D_T = 6.76E-07 Q_T$$

where:  $D_T$  = dose from tritium in mrem

$Q_T$  = curies of tritium released in liquid effluents.

D. For all isotopes other than radioiodine, noble gas, or tritium, calculate the dose to the liver of a teenager from eating fish obtained at the edge of the initial mixing zone.

1. The equation is similar to that for radioiodines in A.1, above, except for a different consumption rate. Consumption rate is 16 Kg/yr.

2. Use the following:

$$D_i = 5.57 Q_i B_i DF_i e^{-\lambda_i t_p}$$

where:  $D_i$  = dose from isotope  $i$  in mrem,

$Q_i$  = curies of isotope  $i$  released,

$B_i$  = bioaccumulation factor for freshwater fish from Table A-1 of Regulatory Guide 1.109 Revision 1,

$DF_i$  = dose conversion factor from Table E-12 of Regulatory Guide 1.109 Revision 1 or NUREG-0172, Table 3 in mrem/pCi ingested for teenager liver.

$\lambda_i$  = decay constant for isotope  $i$  in  $\text{hr}^{-1}$ ,

$t_p$  = holdup time = 24 hours

3. The exponential may be ignored for all isotopes with half-lives longer than two days.

4. Sum the results for all radioisotopes.

The dose to the whole body of an adult from eating fish obtained from the edge of the initial mixing zone is accomplished by utilizing formula A.1 and the appropriate adult whole body dose conversion factors from Table E-11 (or NUREG-0172, Table 4) and bioaccumulation factor from Table A-1 of Regulatory Guide 1.109.

7.0 COMPUTER CALCULATION OF DOSES RESULTING FROM EFFLUENTS

As part of the software being provided for the new meteorological instrumentation at PBNP, a dose assessment program will be provided for application to normal releases. A description and operating instructions will be provided upon completion of installation. Installation is expected to be completed in late 1987. Should dose calculations be required, either the manual technique of Section 6.0 or the computer technique of this section may be used.

8.0

RADIOLOGICAL ENVIRONMENTAL MONITORING PROGRAM

Requirements for the PBNP environmental monitoring program are detailed in Technical Specification 15.7.7. A complete description of the PBNP radiological environmental monitoring program, including procedures and responsibilities, is contained in the PBNP Environmental Manual. The latter is hereby incorporated into the Offsite Dose Calculation Manual (ODCM) by reference.

PBNP FSAR

TABLE I.4-2

POINT BEACH NUCLEAR PLANT  
SUMMARY OF ANNUAL AND GRAZING SEASON X/Q'S AND D/Q'S FOR HIGHEST OFFSITE SECTORS

Release Mode			Highest Sectors for Site Boundary & Animal Locations						Highest Sector for Nearest Resident & Vegetable Garden Location		
Location	Type		S Sector (1,270 m)		SSE Sector (1,300 m)		SSW Sector (1,370 m)				
			X/Q $\times 10^7$	D/Q $\times 10^9$	X/Q $\times 10^7$	D/Q $\times 10^9$	X/Q $\times 10^7$	D/Q $\times 10^9$			
IA Auxiliary Building Vent	Continuous	Conditionally elevated	A	4.01	13.3	A	3.11	20.1	A	2.86	5.90
		GS	2.75	6.78	GS	2.08	11.7	GS	1.57	7.08	
IB Auxiliary Building Vent	Intermittent (during gas decay tank releases)	Conditionally elevated	A	9.36	31.0	A	9.35	60.5	A	8.02	16.6
		GS	7.61	18.8	GS	8.46	47.6	GS	9.02	17.9	
I7A Unit 1 and Unit II Purge Vent	Continuous 10 cfm Vent	Ground Level	A	60.7	47.9	A	19.5	24.6	A	23.9	21.8
		GS	51.9	34.1	GS	13.1	14.7	GS	28.0	26.3	
IIB Unit 1 and Unit II Purge Vent	Intermittent (purge)	Conditionally elevated	A	26.9	47.3	A	16.8	50.2	A	18.9	28.7
		GS	22.3	33.5	GS	12.4	37.8	GS	21.0	30.5	
IIC Gas Stripper Building (through Unit 2 Purge Vent)	Continuous	Ground Level	A	60.7	47.9	A	19.5	24.6	A	23.9	21.8
		GS	51.9	34.1	GS	13.1	14.7	GS	28.0	26.3	
III Turbine Building Roof Exhausters	Continuous	Ground Level	A	70.4	47.9	A	21.0	24.6	A	26.6	21.8
		GS	60.8	34.1	GS	14.1	14.7	GS	31.4	26.3	

Notes: A = Annual Average; GS = Grazing or Growing Season; X/Q in  $\text{sec}/\text{m}^3$ ; D/Q in  $\text{m}^{-2}$   
Units of X/Q are in  $10^{-7} \text{ sec}/\text{m}^3$ , Units of D/Q are in  $10^{-9} \text{ m}^{-2}$

REG. GUIDE 1.109

TABLE A-1

BIOACCUMULATION FACTORS TO BE USED IN THE ABSENCE OF SITE-SPECIFIC DATA  
(pCi/kg per pCi/liter)\*

ELEMENT	FRESHWATER		SALTWATER	
	FISH	INVERTEBRATE	FISH	INVERTEBRATE
H	9.0E-01	9.0E-01	9.0E-01	9.3E-01
C	4.6E 03	9.1E 03	1.8E 03	1.4E 03
NA	1.0E 02	2.0E 02	6.7E-02	1.9E-01
P	1.0E 05	2.0E 04	2.9E 04	3.0E 04
CR	2.0E 02	2.0E 03	4.0E 02	2.0E 03
MN	4.0E 02	9.0E 04	5.5E 02	4.0E 02
FE	1.0E 02	3.2E 03	3.0E 03	2.0E 04
CO	5.0E 01	2.0E 02	1.0E 02	1.0E 03
NI	1.0E 02	1.0E 02	1.0E 02	2.5E 02
CU	5.0E 01	4.0E 02	6.7E 02	1.7E 03
ZN	2.0E 03	1.0E 04	2.0E 03	5.0E 04
BR	4.2E 02	3.3E 02	1.5E-02	3.1E 00
RB	2.0E 03	1.0E 03	8.3E 00	1.7E 01
SR	3.0E 01	1.0E 02	2.0E 00	2.0E 01
Y	2.5E 01	1.0E 03	2.5E 01	1.0E 03
ZR	3.3E 00	6.7E 00	2.0E 02	8.0E 01
NB	3.0E 04	1.0E 02	3.0E 04	1.0E 02
MO	1.0E 01	1.0E 01	1.0E 01	1.0E 01
TC	1.5E 01	5.0E 00	1.0E 01	5.0E 01
RU	1.0E 01	3.0E 02	3.0E 00	1.0E 03
RH	1.0E 01	3.0E 02	1.0E 01	2.0E 03
TE**	4.0E 02	6.1E 03	1.0E 01	1.0E 02
I	1.5E 01	5.0E 00	1.0E 01	5.0E 01
CS	2.0E 03	1.0E 03***	4.0E 01	2.5E 01
BA	4.0E 00	2.0E 02	1.0E 01	1.0E 02
LA	2.5E 01	1.0E 03	2.5E 01	1.0E 03
CE	1.0E 00	1.0E 03	1.0E 01	6.0E 02
PR	2.5E 01	1.0E 03	2.5E 01	1.0E 03
ND	2.5E 01	1.0E 03	2.5E 01	1.0E 03
W	1.2E 03	1.0E 01	3.0E 01	3.0E 01
NP	1.0E 01	4.0E 02	1.0E 01	1.0E 01

\* Values in Table A-1 are taken from Reference 6 unless otherwise indicated.  
 \*\* Data taken from Reference 8.  
 \*\*\* Data taken from Reference 7.

REG. GUIDE 1.109

TABLE B-1

DOSE FACTORS FOR EXPOSURE TO A SEMI-INFINITE CLOUD OF NOBLE GASES

Nuclide	$\beta$ -Air* (DF <sub>1</sub> <sup>β</sup> )	$\beta$ -Skin** (DFS <sub>1</sub> )	$\gamma$ -Air* (DF <sub>1</sub> <sup>γ</sup> )	$\gamma$ -Body** (DFB <sub>1</sub> )
Kr-83m	2.88E-04***	---	1.93E-05	7.56E-08
Kr-85m	1.97E-03	1.46E-03	1.23E-03	1.17E-03
Kr-85	1.95E-03	1.34E-03	1.72E-05	1.61E-05
Kr-87	1.03E-02	9.73E-03	6.17E-03	5.92E-03
Kr-88	2.93E-03	2.37E-03	1.52E-02	1.47E-02
Kr-89	1.06E-02	1.01E-02	1.73E-02	1.66E-02
Kr-90	7.83E-03	7.29E-03	1.63E-02	1.56E-02
Xe-131m	1.11E-03	4.76E-04	1.56E-04	9.15E-05
Xe-133m	1.48E-03	9.94E-04	3.27E-04	2.51E-04
Xe-133	1.05E-03	3.06E-04	3.53E-04	2.94E-04
Xe-135m	7.39E-04	7.11E-04	3.36E-03	3.12E-03
Xe-135	2.46E-03	1.86E-03	1.92E-03	1.81E-03
Xe-137	1.27E-02	1.22E-02	1.51E-03	1.42E-03
Xe-138	4.75E-03	4.13E-03	9.21E-03	8.83E-03
Ar-41	3.28E-03	2.69E-03	9.30E-03	8.84E-03

\*  $\frac{\text{mrad-m}^3}{\text{pCi-yr}}$

\*\*  $\frac{\text{mrem-m}^3}{\text{pCi-yr}}$

\*\*\* 2.88E-04 = 2.88 x 10<sup>-4</sup>



REG. GUIDE 1.109

TABLE E-4  
RECOMMENDED VALUES FOR  $U_{AD}$  TO BE USED FOR THE AVERAGE INDIVIDUAL  
IN LIEU OF SITE-SPECIFIC DATA

Pathway	Child	Teen	Adult
Fruits, vegetables, & grain (kg/yr)*	200	240	190
Milk (L/yr)*	170	200	110
Meat & poultry (kg/yr)*	37	59	95
Fish (kg/yr)*	2.2	5.2	6.9
Seafood (kg/yr)*	0.33	0.75	1.0
Drinking water (L/yr)**	260	260	370
Shoreline recreation (hr/yr)**	9.5	47	8.3
Inhalation (m <sup>3</sup> /yr)	3700***	8000***	8000†

\* Consumption rate obtained from Reference 19 and age-prorated using techniques in Reference 10.

\*\* Data obtained directly from Reference 10.

\*\*\* Inhalation rate derived from data provided in Reference 20.

† Data obtained directly from Reference 20.

TABLE E-5  
RECOMMENDED VALUES FOR  $U_{AD}$  TO BE USED FOR THE MAXIMUM EXPOSED  
INDIVIDUAL IN LIEU OF SITE-SPECIFIC DATA

Pathway	Infant	Child	Teen	Adult
Fruits, vegetables & grain (kg/yr)*, **	-	520	630	520
Leafy vegetables (kg/yr)*	-	26	42	64
Milk (L/yr)*	330	330	400	310
Meat & poultry (kg/yr)*	-	41	65	110
Fish (fresh or salt) (kg/yr)***	-	6.9	16	21
Other seafood (kg/yr)*	-	1.7	3.8	5
Drinking water (L/yr)†	330	510	510	730
Shoreline recreation (hr/yr)†	-	14	67	12
Inhalation (m <sup>3</sup> /yr)	1400**	3700***	8000***	8000**

\* Consumption rate obtained from Reference 19 for average individual and age-prorated and maximized using techniques contained in Reference 10.

\*\* Consists of the following (on a mass basis): 22% fruit, 54% vegetables (including leafy vegetables), and 24% grain.

\*\*\* Consumption rate for adult obtained by averaging data from References 10 and 21-24 and age-prorated using techniques contained in Reference 10.

† Data obtained directly from Reference 10.

\*\* Data obtained directly from Reference 20.

\*\*\* Inhalation rate derived from data provided in Reference 20.

REG. GUIDE 1.109

TABLE E-7

PAGE 1 OF 3

INHALATION DOSE FACTORS FOR ADULTS  
(MREM PER MCI INHALED)

NUCLIDE	BONE	LIVER	T. BODY	THYROID	KIDNEY	LUNG	GI-LLI
H 3	NO DATA	1.58E-07	1.58E-07	1.58E-07	1.58E-07	1.58E-07	1.58E-07
C 14	2.27E-06	4.26E-07	4.26E-07	4.26E-07	4.26E-07	4.26E-07	4.26E-07
CA 24	1.28E-06	1.28E-06	1.28E-06	1.28E-06	1.28E-06	1.28E-06	1.28E-06
P 32	1.65E-04	9.64E-06	6.26E-06	NO DATA	NO DATA	NO DATA	1.08E-05
CR 51	NO DATA	NO DATA	1.25E-08	7.44E-09	2.85E-09	1.80E-06	4.15E-07
NN 54	NO DATA	4.95E-06	7.87E-07	NO DATA	1.23E-06	1.75E-04	9.67E-06
MN 56	NO DATA	1.55E-10	2.29E-11	NO DATA	1.63E-10	1.18E-06	2.53E-06
FE 55	3.07E-06	2.12E-06	4.93E-07	NO DATA	NO DATA	9.01E-06	7.54E-07
FE 59	1.47E-06	3.47E-06	1.32E-06	NO DATA	NO DATA	1.27E-04	2.35E-05
CO 58	NO DATA	1.98E-07	2.59E-07	NO DATA	NO DATA	1.16E-04	1.33E-05
CO 60	NO DATA	1.44E-06	1.85E-06	NO DATA	NO DATA	7.45E-04	3.56E-05
NI 63	5.40E-05	3.93E-06	1.81E-06	NO DATA	NO DATA	2.23E-05	1.67E-06
VI 65	1.92E-10	2.62E-11	1.14E-11	NO DATA	NO DATA	7.00E-07	1.54E-06
CU 64	NO DATA	1.83E-10	7.69E-11	NO DATA	3.78E-10	8.48E-07	6.12E-06
ZN 65	4.05E-06	1.29E-05	3.82E-06	NO DATA	8.62E-06	1.08E-04	6.68E-06
ZN 69	4.23E-12	8.14E-12	5.65E-13	NO DATA	5.27E-12	1.15E-07	2.04E-09
BR 83	NO DATA	NO DATA	3.01E-08	NO DATA	NO DATA	NO DATA	2.90E-08
BR 84	NO DATA	NO DATA	3.91E-08	NO DATA	NO DATA	NO DATA	2.05E-13
BR 85	NO DATA	NO DATA	1.60E-09	NO DATA	NO DATA	NO DATA	LT E-24
RE 86	NO DATA	1.69E-05	7.37E-06	NO DATA	NO DATA	NO DATA	2.06E-06
RB 88	NO DATA	4.84E-08	2.41E-08	NO DATA	NO DATA	NO DATA	4.18E-19
RB 89	NO DATA	3.20E-08	2.12E-08	NO DATA	NO DATA	NO DATA	1.16E-21
SR 89	3.80E-05	NO DATA	1.09E-04	NO DATA	NO DATA	1.75E-04	4.37E-05
SR 90	1.24E-02	NO DATA	7.67E-04	NO DATA	NO DATA	1.20E-03	9.02E-05
SR 91	7.74E-09	NO DATA	3.13E-10	NO DATA	NO DATA	4.56E-06	2.39E-05
SR 92	8.43E-10	NO DATA	3.64E-11	NO DATA	NO DATA	2.06E-06	5.38E-06
Y 90	2.61E-07	NO DATA	7.01E-09	NO DATA	NO DATA	2.12E-05	6.32E-05
Y 91H	3.26E-11	NO DATA	1.27E-12	NO DATA	NO DATA	2.40E-07	1.64E-10
Y 91	5.78E-05	NO DATA	1.55E-06	NO DATA	NO DATA	2.13E-04	4.81E-05
Y 92	1.29E-09	NO DATA	3.77E-11	NO DATA	NO DATA	1.96E-06	9.19E-06

TABLE E-7, CONT'D

PAGE 2 OF 3

INHALATION DOSE FACTORS FOR ADULTS  
(MREM PER MCI INHALED)

NUCLIDE	BONE	LIVER	T. BODY	THYROID	KIDNEY	LUNG	GI-LLI
Y 93	1.18E-08	NO DATA	3.26E-10	NO DATA	NO DATA	6.06E-06	5.27E-05
ZR 95	1.34E-05	4.30E-06	2.91E-06	NO DATA	6.77E-06	2.21E-04	1.80E-05
ZN 97	1.21E-08	2.45E-09	1.13E-09	NO DATA	3.71E-09	9.84E-06	6.56E-05
NO 95	1.76E-06	9.77E-07	5.26E-07	NO DATA	9.67E-07	6.31E-05	1.36E-05
NO 99	NO DATA	1.11E-08	2.87E-09	NO DATA	3.64E-08	1.14E-05	5.10E-05
TC 99H	1.79E-13	3.64E-13	4.63E-12	NO DATA	5.52E-12	9.55E-08	5.20E-07
TC101	5.22E-15	7.52E-15	7.38E-14	NO DATA	1.35E-13	4.99E-08	1.36E-21
RU103	1.91E-07	NO DATA	8.23E-08	NO DATA	7.29E-07	6.31E-05	1.38E-05
RU105	9.88E-11	NO DATA	3.89E-11	NO DATA	1.77E-10	1.37E-04	6.22E-06
RU106	8.66E-06	NO DATA	1.09E-06	NO DATA	1.67E-05	1.17E-03	1.14E-04
AG110P	1.35E-06	1.21E-06	7.43E-07	NO DATA	2.46E-06	5.79E-04	3.78E-05
TE125H	4.27E-07	1.99E-07	5.94E-08	1.31E-07	1.55E-06	3.92E-05	8.83E-06
TE127H	1.58E-06	7.21E-07	1.96E-07	4.11E-07	5.72E-06	1.20E-04	1.87E-05
TE127	1.75E-10	8.07E-11	3.87E-11	1.32E-10	4.37E-10	8.14E-07	7.17E-06
TE129H	1.22E-06	5.84E-07	1.98E-07	4.30E-07	4.57E-06	1.45E-04	4.79E-05
TE129	6.22E-12	2.99E-12	1.55E-12	4.87E-12	2.34E-11	2.42E-07	1.96E-08
TE131H	8.74E-04	5.45E-09	3.63E-09	6.88E-09	3.86E-08	1.82E-05	6.99E-05
TF131	1.39E-12	7.44E-13	4.49E-13	1.17E-12	5.64E-12	1.74E-07	2.38E-04
TE132	3.25E-08	2.69E-08	2.02E-08	2.37E-08	1.82E-07	3.60E-05	6.37E-05
I 130	5.72E-07	1.18E-06	6.60E-07	1.42E-04	2.61E-05	NO DATA	9.61E-07
I 131	3.15E-06	4.47E-06	2.56E-06	1.49E-03	7.66E-06	NO DATA	7.85E-07
I 132	1.45E-07	4.07E-07	1.45E-07	1.43E-07	6.48E-07	NO DATA	5.08E-08
I 133	1.08E-06	1.85E-06	5.65E-07	2.39E-06	3.23E-06	NO DATA	1.11E-06
I 134	5.00E-08	2.16E-07	7.69E-08	3.73E-06	3.46E-07	NO DATA	1.26E-10
I 135	3.35E-07	8.73E-07	3.21E-07	5.60E-05	1.39E-06	NO DATA	6.96E-07
CS134	4.66E-05	1.06E-04	9.10E-05	NO DATA	3.54E-05	1.22E-05	1.90E-06
CS136	4.88E-06	1.83E-05	1.38E-05	NO DATA	1.07E-05	1.50E-06	1.46E-06
CS137	5.98E-05	7.74E-05	9.35E-05	NO DATA	2.78E-05	9.40E-06	1.05E-06
CS138	4.14E-08	7.71E-08	4.05E-08	NO DATA	6.00E-08	6.07E-09	2.33E-13
BA139	1.17E-10	3.32E-14	3.42E-12	NO DATA	7.78E-14	4.70E-07	1.12E-07

REG. GUIDE 1.109

TABLE E-7, CONT'D

PAGE 3 OF 3

INHALATION DOSE FACTORS FOR ADULTS  
(MMB PER PCI INHALED)

NUCLIDE	BONE	LIVER	T. BODY	THYROID	KIDNEY	LUNG	GI-LLI
HA 140	4.88E-06	6.13E-09	1.71E-07	NO DATA	2.09E-09	1.59E-04	2.73E-05
HA 141	1.25E-11	9.41E-15	4.20E-13	NO DATA	8.75E-15	2.42E-07	1.45E-17
HA 142	3.29E-12	3.38E-15	2.07E-13	NO DATA	2.86E-15	1.49E-07	1.96E-26
LA 140	4.30E-08	2.17E-08	5.73E-09	NO DATA	NO DATA	1.70E-05	5.73E-05
LA 142	8.54E-11	3.88E-11	9.64E-12	NO DATA	NO DATA	7.91E-07	2.64E-07
CE 141	2.49E-06	1.69E-06	1.91E-07	NO DATA	7.83E-07	4.52E-05	1.50E-05
CE 143	2.33E-09	1.72E-08	1.91E-09	NO DATA	7.60E-09	9.97E-06	2.83E-05
CE 144	4.29E-04	1.79E-04	2.30E-05	NO DATA	1.06E-04	9.72E-04	1.02E-04
LR 143	1.17E-06	4.69E-07	5.89E-08	NO DATA	2.70E-07	3.51E-05	2.50E-05
PR 144	3.76E-12	1.36E-12	1.91E-13	NO DATA	8.81E-13	1.27E-07	2.69E-18
ND 147	6.59E-07	7.62E-07	4.56E-08	NO DATA	4.45E-07	2.76E-05	2.16E-05
M 187	1.06E-09	8.85E-10	3.10E-10	NO DATA	NO DATA	3.63E-06	1.94E-05
NP 239	2.87E-08	2.82E-09	1.54E-09	NO DATA	8.75E-09	4.70E-04	1.49E-05

TABLE E-8

PAGE 1 OF 3

INHALATION DOSE FACTORS FOR TEENAGER  
(MMB PER PCI INHALED)

NUCLIDE	BONE	LIVER	T. BODY	THYROID	KIDNEY	LUNG	GI-LLI
H 3	NO DATA	1.59E-07	1.59E-07	1.59E-07	1.59E-07	1.59E-07	1.59E-07
C 14	2.25E-06	6.09E-07	6.09E-07	6.09E-07	6.09E-07	6.09E-07	6.09E-07
JA 24	1.72E-06	1.72E-06	1.72E-06	1.72E-06	1.72E-06	1.72E-06	1.72E-06
P 32	2.36E-04	1.37E-05	8.95E-06	NO DATA	NO DATA	NO DATA	1.16E-05
CR 51	NO DATA	NO DATA	1.69E-08	9.37E-09	3.94E-09	2.62E-06	3.75E-07
KN 54	NO DATA	6.37E-06	1.05E-06	NO DATA	1.59E-06	2.48E-04	8.35E-04
KN 56	NO DATA	1.12E-10	5.15E-11	NO DATA	2.24E-10	1.90E-06	7.18E-06
FE 55	4.18E-06	2.98E-06	6.93E-07	NO DATA	NO DATA	1.55E-05	7.99E-07
FE 57	1.79E-06	4.62E-06	1.79E-06	NO DATA	NO DATA	1.91E-04	2.23E-05
CO 58	NO DATA	2.59E-07	3.47E-07	NO DATA	NO DATA	1.68E-04	1.19E-05
CU 60	NO DATA	1.89E-06	2.48E-06	NO DATA	NO DATA	1.09E-03	3.24E-05
NI 63	7.25E-05	5.43E-06	2.47E-06	NO DATA	NO DATA	3.84E-05	1.77E-06
SI 65	2.73E-10	3.66E-11	1.59E-11	NO DATA	NO DATA	1.17E-06	4.59E-06
CU 64	NO DATA	2.54E-10	1.06E-10	NO DATA	8.01E-10	1.99E-06	7.68E-06
ZN 65	4.62E-06	1.67E-05	7.80E-06	NO DATA	1.08E-05	1.55E-04	5.83E-06
ZN 69	6.04E-12	1.15E-11	8.07E-13	NO DATA	7.53E-12	1.98E-07	3.54E-08
WR 83	NO DATA	NO DATA	4.30E-08	NO DATA	NO DATA	NO DATA	LT E-24
WR 84	NO DATA	NO DATA	5.41E-08	NO DATA	NO DATA	NO DATA	LT E-24
NR 85	NO DATA	NO DATA	2.29E-09	NO DATA	NO DATA	NO DATA	LT E-24
NR 86	NO DATA	2.38E-05	1.05E-05	NO DATA	NO DATA	NO DATA	2.21E-06
NR 88	NO DATA	6.82E-08	3.40E-08	NO DATA	NO DATA	NO DATA	3.65E-15
RR 89	NO DATA	4.40E-08	2.91E-08	NO DATA	NO DATA	NO DATA	4.22E-17
SR 89	5.43E-05	NO DATA	1.56E-04	NO DATA	NO DATA	3.02E-04	4.64E-05
SR 90	1.35E-02	NO DATA	8.35E-04	NO DATA	NO DATA	2.06E-03	9.54E-05
SR 91	1.10E-08	NO DATA	4.39E-10	NO DATA	NO DATA	7.59E-04	3.24E-05
SR 92	1.19E-09	NO DATA	5.08E-11	NO DATA	NO DATA	3.43E-04	1.49E-05
Y 90	3.73E-07	NO DATA	1.00E-08	NO DATA	NO DATA	3.66E-05	6.99E-05
Y 91*	4.63E-11	NO DATA	1.77E-12	NO DATA	NO DATA	4.00E-07	3.77E-09
Y 91	8.26E-05	NO DATA	2.21E-06	NO DATA	NO DATA	3.47E-04	5.11E-05
Y 92	1.84E-09	NO DATA	5.36E-11	NO DATA	NO DATA	3.33E-04	2.04E-05

REG. GUIDE 1.109

TABLE E-8, CONT'D

PAGE 2 OF 3

INHALATION DOSE FACTORS FOR TEENAGER  
(MKEM PER PCI INHALED)

NUCLIDE	BONE	LIVER	T. BODY	THYROID	KIDNEY	LUNG	GI-LLI
Y 93	1.69E-08	NO DATA	4.65E-10	NO DATA	NO DATA	1.04E-05	7.24E-05
Zr 95	1.82E-05	5.73E-06	3.94E-06	NO DATA	8.42E-06	3.36E-04	1.86E-05
Zr 97	1.72E-08	3.40E-09	1.57E-09	NO DATA	5.15E-09	1.62E-05	7.88E-05
Nb 95	2.32E-06	1.29E-06	7.08E-07	NO DATA	1.25E-06	9.39E-05	1.21E-05
MO 99	NO DATA	2.11E-08	4.03E-09	NO DATA	5.14E-08	1.92E-05	3.36E-05
TC 99M	1.73E-13	4.83E-13	6.24E-12	NO DATA	7.20E-12	1.44E-07	7.66E-07
TC101	7.40E-15	1.05E-14	1.03E-13	NO DATA	1.90E-13	8.34E-08	1.09E-16
RU103	2.63E-07	NO DATA	1.12E-07	NO DATA	9.29E-07	9.79E-05	1.36E-05
RU105	1.40E-10	NO DATA	5.42E-11	NO DATA	1.76E-10	2.27E-06	1.13E-05
RU106	1.23E-05	NO DATA	1.55E-06	NO DATA	5.38E-05	2.01E-03	1.20E-04
AG110M	1.73E-06	1.64E-06	9.97E-07	NO DATA	3.13E-06	8.44E-04	3.41E-05
TE125M	6.10E-07	2.80E-07	6.34E-08	1.75E-07	NO DATA	6.70E-05	9.38E-06
TE127M	2.25E-06	1.02E-06	2.73E-07	5.48E-07	8.17E-06	2.07E-04	1.99E-05
TE127	2.51E-10	1.14E-10	5.52E-11	1.77E-10	9.10E-10	1.40E-06	1.01E-05
TE129M	1.74E-06	8.23E-07	2.81E-07	5.72E-07	6.49E-06	2.47E-04	5.04E-05
TE129	8.87E-12	4.22E-12	2.20E-12	6.49E-12	3.32E-11	4.12E-07	2.02E-07
TE131M	1.23E-08	7.51E-09	5.03E-09	9.06E-09	5.49E-08	2.97E-05	7.76E-05
TE131	1.97E-12	1.04E-12	6.30E-13	1.55E-12	7.72E-12	2.92E-07	1.69E-09
TC132	4.50E-08	3.63E-08	2.74E-08	3.07E-08	2.44E-07	5.61E-05	5.79E-05
I 130	7.11E-07	2.24E-06	8.96E-07	1.86E-04	3.44E-06	NO DATA	1.54E-06
I 131	4.43E-05	3.14E-06	3.30E-06	1.83E-03	1.05E-05	NO DATA	8.11E-07
I 132	1.99E-07	5.47E-07	1.97E-07	1.89E-05	8.65E-07	NO DATA	1.59E-07
I 133	1.52E-06	2.56E-06	7.78E-07	3.65E-04	4.49E-06	NO DATA	1.29E-06
I 134	1.11E-07	2.90E-07	1.05E-07	4.94E-06	4.58E-07	NO DATA	2.55E-09
I 135	4.62E-07	1.18E-06	4.36E-07	7.76E-05	1.86E-06	NO DATA	8.69E-07
CS134	6.28E-05	1.41E-04	6.86E-05	NO DATA	4.69E-05	1.83E-05	1.22E-06
CS136	6.44E-06	2.42E-05	1.71E-05	NO DATA	1.38E-05	2.22E-06	1.36E-06
CS137	8.38E-05	1.06E-04	3.89E-05	NO DATA	3.80E-05	1.51E-05	1.04E-06
CS138	5.82E-08	1.07E-07	5.58E-08	NO DATA	8.28E-08	9.84E-09	3.38E-11
BP139	1.67E-10	1.18E-13	4.87E-12	NO DATA	1.11E-13	6.08E-07	8.64E-07

TABLE E-8, CONT'D

PAGE 3 OF 3

INHALATION DOSE FACTORS FOR TEENAGER  
(MKEM PER PCI INHALED)

NUCLIDE	BONE	LIVER	T. BODY	THYROID	KIDNEY	LUNG	GI-LLI
BA140	6.84E-06	8.58E-09	4.40E-07	NO DATA	2.85E-09	2.54E-04	2.86E-05
BA141	1.78E-11	1.22E-14	5.91E-13	NO DATA	1.23E-14	4.11E-07	9.33E-14
BA142	4.62E-12	4.63E-15	2.84E-13	NO DATA	3.92E-15	2.39E-07	5.99E-20
LA140	5.99E-08	2.95E-08	7.82E-09	NO DATA	NO DATA	2.68E-05	6.09E-05
LA141	1.20E-10	5.31E-11	1.32E-11	NO DATA	NO DATA	1.27E-06	1.50E-06
CE141	3.55E-06	2.97E-06	2.71E-07	NO DATA	1.11E-06	7.67E-05	1.58E-05
CE143	3.32E-08	2.42E-08	2.70E-09	NO DATA	1.08E-08	1.63E-05	3.19E-05
CE144	6.11E-04	2.53E-04	3.28E-05	NO DATA	1.51E-04	1.47E-03	1.08E-04
PR143	1.67E-06	6.64E-07	8.28E-08	NO DATA	3.86E-07	6.04E-05	2.67E-05
PR144	5.37E-12	2.20E-12	2.72E-13	NO DATA	1.26E-12	2.19E-07	2.94E-14
NC147	9.83E-07	1.07E-06	6.41E-08	NO DATA	6.28E-07	4.65E-05	2.28E-05
W 187	1.50E-09	1.22E-09	4.29E-10	NO DATA	NO DATA	5.92E-06	2.21E-05
MP239	4.23E-08	3.49E-09	2.21E-09	NO DATA	1.75E-08	8.11E-06	1.65E-05

REG. GUIDE 1.109

TABLE E-7

PAGE 1 OF 3

INHALATION DOSE FACTORS FOR CHILD  
(MKEM PER PCI INHALED)

NUCLIDE	BONE	LIVER	T.BODY	THYROID	KIDNEY	LUNG	GI-LLI
H 3	NO DATA	3.74E-07	3.04E-07	3.04E-07	3.04E-07	3.04E-07	3.04E-07
C 14	9.70E-06	1.82E-06	1.82E-06	1.82E-06	1.82E-06	1.82E-06	1.82E-06
NA 24	4.35E-06	4.35E-06	4.35E-06	4.35E-06	4.35E-06	4.35E-06	4.35E-06
P 32	7.04E-04	3.09E-05	2.67E-05	NO DATA	NO DATA	NO DATA	1.14E-05
CR 51	NO DATA	NO DATA	4.17E-08	2.31E-08	6.57E-09	4.59E-06	2.93E-07
MN 54	NO DATA	1.16E-05	2.57E-06	NO DATA	2.71E-06	4.26E-04	6.19E-06
MN 56	NO DATA	4.48E-10	8.43E-11	NO DATA	4.52E-10	3.55E-06	3.33E-05
FE 55	1.28E-05	6.80E-06	2.10E-06	NO DATA	NO DATA	3.00E-05	7.79E-07
FE 57	5.59E-06	9.14E-06	4.51E-06	NO DATA	NO DATA	3.43E-04	1.91E-05
CO 58	NO DATA	4.79E-07	6.55E-07	NO DATA	NO DATA	2.99E-04	9.29E-06
CO 60	NO DATA	3.55E-06	6.12E-06	NO DATA	NO DATA	1.91E-03	2.60E-05
NI 63	2.22E-04	1.25E-05	7.56E-06	NO DATA	NO DATA	7.43E-05	1.71E-06
ZI 65	8.08E-10	7.99E-11	4.44E-11	NO DATA	NO DATA	2.21E-06	2.27E-05
CU 64	NO DATA	5.39E-10	2.90E-10	NO DATA	1.63E-09	2.59E-06	9.92E-06
ZN 65	1.15E-05	3.06E-05	1.90E-05	NO DATA	1.93E-05	2.69E-04	4.41E-06
ZY 67	1.81E-11	2.61E-11	2.41E-12	NO DATA	1.58E-11	3.84E-07	2.75E-06
HR 83	NO DATA	NO DATA	1.28E-07	NO DATA	NO DATA	NO DATA	LT E-24
JR 84	NO DATA	NO DATA	1.48E-07	NO DATA	NO DATA	NO DATA	LT E-24
PT 85	NO DATA	NO DATA	6.84E-09	NO DATA	NO DATA	NO DATA	LT E-24
NR 86	NO DATA	5.36E-05	3.09E-05	NO DATA	NO DATA	NO DATA	2.16E-06
KP 88	NO DATA	1.52E-07	9.90E-08	NO DATA	NO DATA	NO DATA	4.66E-09
RE 89	NO DATA	9.33E-08	7.85E-08	NO DATA	NO DATA	NO DATA	5.11E-10
SR 89	1.62E-04	NO DATA	4.66E-06	NO DATA	NO DATA	5.83E-04	4.52E-05
SR 90	2.73E-02	NO DATA	1.74E-03	NO DATA	NO DATA	3.99E-03	7.28E-05
SP 91	3.28E-04	NO DATA	1.24E-04	NO DATA	NO DATA	1.44E-05	4.70E-05
SR 92	3.54E-09	NO DATA	1.42E-10	NO DATA	NO DATA	6.49E-06	6.55E-05
Y 90	1.11E-06	NO DATA	2.94E-08	NO DATA	NO DATA	7.07E-05	7.24E-05
Y 91*	1.17E-10	NO DATA	4.98E-12	NO DATA	NO DATA	7.60E-07	4.64E-07
Y 91	2.47E-04	NO DATA	6.59E-06	NO DATA	NO DATA	7.10E-04	4.97E-05
Y 92	5.50E-09	NO DATA	1.57E-10	NO DATA	NO DATA	6.46E-06	6.46E-05

TABLE E-9, CONT'D

PAGE 2 OF 3

INHALATION DOSE FACTORS FOR CHILD  
(MKEM PER PCI INHALED)

NUCLIDE	BONE	LIVER	T.BODY	THYROID	KIDNEY	LUNG	GI-LLI
Y 91	5.04E-08	NO DATA	1.38E-09	NO DATA	NO DATA	2.01E-05	1.05E-04
ZR 95	5.13E-05	1.13E-05	1.00E-05	NO DATA	1.61E-05	6.03E-04	1.65E-05
ZR 97	5.07E-08	7.34E-09	4.32E-09	NO DATA	1.05E-08	3.06E-05	6.49E-05
NR 99	6.35E-06	2.48E-06	1.77E-06	NO DATA	2.33E-06	1.66E-04	1.00E-05
NO 99	NO DATA	4.66E-06	1.15E-08	NO DATA	1.06E-07	3.66E-05	3.42E-05
TC 99*	4.81E-13	9.41E-13	1.56E-11	NO DATA	1.37E-11	7.57E-07	1.30E-06
TC101	2.19E-14	2.30E-14	2.91E-13	NO DATA	3.92E-13	1.58E-07	4.41E-09
RU103	7.55E-07	NO DATA	2.90E-07	NO DATA	1.90E-06	1.79E-04	1.21E-05
RU105	4.13E-10	NO DATA	1.50E-10	NO DATA	3.63E-10	4.30E-06	2.69E-05
RU106	3.68E-07	NO DATA	4.57E-06	NO DATA	4.97E-05	3.87E-03	1.16E-04
AG110*	4.56E-06	3.08E-06	2.47E-06	NO DATA	5.74E-06	1.48E-03	2.71E-05
TE125*	1.82E-06	6.29E-07	2.47E-07	5.20E-07	NO DATA	1.29E-04	9.13E-06
TE127*	6.72E-06	2.31E-06	8.10E-07	1.64E-06	1.72E-05	4.00E-04	1.93E-05
TE127	7.49E-10	2.57E-10	1.65E-10	5.30E-10	1.91E-09	2.71E-06	1.52E-05
TE127*	5.19E-06	1.85E-06	8.22E-07	1.71E-06	1.56E-05	4.76E-04	4.91E-05
TE129	2.64E-11	9.45E-12	6.44E-12	1.93E-11	6.94E-11	7.93E-07	6.89E-06
TE131*	3.63E-08	1.60E-08	1.37E-08	2.64E-08	1.08E-07	5.56E-05	8.32E-05
TE131	5.87E-12	2.28E-12	1.78E-12	4.59E-12	1.59E-11	1.55E-07	3.60E-07
TE132	1.30E-07	7.36E-08	7.12E-08	8.58E-08	4.79E-07	1.02E-04	3.72E-05
I 130	2.21E-06	4.43E-06	2.28E-06	4.99E-06	6.61E-06	NO DATA	1.38E-06
I 131	1.30E-05	1.30E-05	7.57E-06	4.39E-05	2.13E-05	NO DATA	7.68E-07
I 132	5.72E-07	1.10E-06	5.07E-07	5.23E-05	1.69E-06	NO DATA	8.65E-07
I 133	4.48E-06	5.49E-06	2.06E-06	1.04E-03	9.13E-06	NO DATA	1.48E-06
I 134	3.17E-07	5.84E-07	2.67E-07	1.37E-05	6.92E-07	NO DATA	2.58E-07
I 135	1.33E-06	2.36E-06	1.12E-06	2.14E-04	3.62E-06	NO DATA	1.20E-06
CS134	1.76E-04	2.74E-04	6.07E-05	NO DATA	8.93E-05	3.27E-05	1.04E-06
CS136	1.76E-05	4.62E-05	3.14E-05	NO DATA	2.58E-05	9.93E-06	1.13E-06
CS137	2.45E-04	2.23E-04	3.47E-05	NO DATA	7.63E-05	2.81E-05	9.78E-07
CS138	1.71E-07	2.27E-07	1.50E-07	NO DATA	1.68E-07	1.84E-08	7.29E-08
RA139	4.98E-10	2.66E-10	1.45E-11	NO DATA	2.33E-10	1.56E-06	1.56E-05

REG. GUIDE 1.109

TABLE E-9. CONT'D

PAGE 3 OF 3

INHALATION DOSE FACTORS FOR CHILD  
(MMER PER PCI INHALED)

NUCLIDE	BONE	LIVER	T. BODY	THYROID	KIDNEY	LUNG	GI-LLI
DA140	2.00E-05	1.75E-08	1.17E-06	NO DATA	5.71E-09	4.71E-04	2.75E-05
BA141	5.29E-11	2.95E-14	1.72E-12	NO DATA	2.56E-14	7.89E-07	7.44E-08
BA142	1.35E-11	7.73E-15	7.54E-13	NO DATA	7.87E-15	4.44E-07	7.41E-10
LA140	1.74E-07	6.08E-08	2.04E-08	NO DATA	NO DATA	4.94E-05	6.10E-05
LA142	3.50E-10	1.11E-10	3.49E-11	NO DATA	NO DATA	2.35E-06	2.05E-05
CE141	1.06E-05	5.28E-06	7.83E-07	NO DATA	2.31E-06	1.47E-04	1.43E-05
CE143	9.89E-08	5.17E-08	7.77E-09	NO DATA	2.26E-06	2.12E-05	3.44E-05
CE144	1.83E-03	5.72E-04	9.77E-05	NO DATA	3.17E-04	3.23E-03	1.05E-04
PR143	4.99E-06	1.50E-06	2.47E-07	NO DATA	8.11E-07	1.17E-04	2.63E-05
PR144	1.61E-11	4.99E-12	8.10E-13	NO DATA	2.64E-12	4.23E-07	5.32E-08
ND147	2.92E-06	2.36E-06	1.84E-07	NO DATA	1.30E-06	8.87E-05	2.22E-05
W 187	4.41E-09	2.61E-09	1.17E-09	NO DATA	NO DATA	1.11E-05	2.44E-05
NR239	1.76E-07	9.04E-09	6.35E-09	NO DATA	2.63E-08	1.57E-05	1.73E-05

TABLE E-10

PAGE 1 OF 3

INHALATION DOSE FACTORS FOR INFANT  
(MMER PER PCI INHALED)

NUCLIDE	BONE	LIVER	T. BODY	THYROID	KIDNEY	LUNG	GI-LLI
H 3	NO DATA	4.62E-07	4.62E-07	4.62E-07	4.62E-07	4.62E-07	4.62E-07
C 14	1.89E-05	3.79E-06	3.79E-06	3.79E-06	3.79E-06	3.79E-06	3.79E-06
NA 24	7.54E-06	7.54E-06	7.54E-06	7.54E-06	7.54E-06	7.54E-06	7.54E-06
P 32	1.45E-03	8.03E-05	5.53E-05	NO DATA	NO DATA	NO DATA	1.15E-05
CF 51	NO DATA	NO DATA	6.37E-08	4.11E-08	9.45E-09	9.17E-06	2.55E-07
RN 84	NO DATA	1.81E-05	3.56E-06	NO DATA	3.56E-06	7.14E-04	5.04E-06
MN 54	NO DATA	1.10E-09	1.58E-10	NO DATA	7.86E-10	8.95E-06	5.17E-05
FE 55	1.41E-05	8.59E-06	2.38E-06	NO DATA	NO DATA	6.21E-05	7.82E-07
FE 59	9.69E-06	1.68E-05	6.77E-06	NO DATA	NO DATA	7.25E-04	1.77E-05
CO 58	NO DATA	8.71E-07	1.30E-06	NO DATA	NO DATA	5.55E-04	7.95E-06
CO 60	NO DATA	5.73E-06	8.41E-06	NO DATA	NO DATA	3.22E-03	2.28E-05
NI 63	2.42E-04	1.46E-05	8.29E-06	NO DATA	NO DATA	1.49E-04	1.73E-06
NI 65	1.71E-09	2.03E-10	8.79E-11	NO DATA	NO DATA	5.80E-06	3.58E-05
CU 64	NO DATA	1.34E-09	5.53E-10	NO DATA	2.84E-09	6.64E-06	1.07E-05
ZN 65	1.38E-05	4.47E-05	2.22E-05	NO DATA	2.32E-05	4.62E-04	3.67E-05
ZN 69	3.85E-11	6.91E-11	5.13E-12	NO DATA	2.87E-11	1.05E-06	9.44E-06
BR 83	NO DATA	NO DATA	2.72E-07	NO DATA	NO DATA	NO DATA	LT E-24
BR 84	NO DATA	NO DATA	2.86E-07	NO DATA	NO DATA	NO DATA	LT E-24
BR 87	NO DATA	NO DATA	1.46E-08	NO DATA	NO DATA	NO DATA	LT E-24
XB 86	NO DATA	1.36E-04	6.30E-05	NO DATA	NO DATA	NO DATA	2.17E-06
RB 88	NO DATA	3.98E-07	2.00E-07	NO DATA	NO DATA	NO DATA	2.42E-07
RE 89	NO DATA	2.29E-07	1.47E-07	NO DATA	NO DATA	NO DATA	4.87E-08
SR 89	2.84E-04	NO DATA	8.15E-06	NO DATA	NO DATA	1.45E-03	4.57E-05
SR 90	2.92E-02	NO DATA	1.85E-03	NO DATA	NO DATA	8.03E-03	9.36E-05
SR 91	6.83E-08	NO DATA	2.47E-09	NO DATA	NO DATA	3.76E-05	5.24E-05
SR 92	7.50E-09	NO DATA	2.79E-10	NO DATA	NO DATA	1.70E-05	1.00E-04
Y 90	2.35E-06	NO DATA	6.30E-08	NO DATA	NO DATA	1.92E-04	7.43E-05
Y 91P	2.91E-10	NO DATA	9.40E-12	NO DATA	NO DATA	1.99E-06	1.68E-06
Y 91	4.20E-04	NO DATA	1.12E-05	NO DATA	NO DATA	1.75E-03	5.02E-05
Y 92	1.17E-08	NO DATA	3.29E-10	NO DATA	NO DATA	1.75E-05	9.04E-05

REG. GUIDE 1.109

TABLE E-10, CONT'D

PAGE 2 OF 3

INHALATION DOSE FACTORS FOR INFANT  
(MREM PER PCI INHALED)

MUCLICE	BONE	LIVER	T.BODY	THYROID	KIDNEY	LUNG	GI-LLI
Y 93	1.07E-07	NO DATA	2.91E-09	NO DATA	NO DATA	5.46E-05	1.19E-04
ZR 95	8.24E-05	1.99E-05	1.45E-05	NO DATA	2.22E-05	1.25E-03	1.55E-05
ZR 97	1.07E-07	1.83E-08	8.36E-09	NO DATA	1.85E-08	7.88E-05	1.00E-04
NB 94	1.12E-05	4.59E-06	2.70E-06	NO DATA	3.37E-06	3.42E-04	9.05E-06
NO 99	NO DATA	1.18E-07	2.31E-08	NO DATA	1.89E-07	9.63E-05	3.48E-05
TC 99M	9.98E-13	2.06E-12	2.66E-11	NO DATA	2.22E-11	5.79E-07	1.45E-06
TC101	4.65E-14	5.98E-14	5.80E-13	NO DATA	6.99E-13	4.17E-07	6.03E-07
MU103	1.44E-06	NO DATA	4.85E-07	NO DATA	3.03E-06	3.94E-04	1.15E-05
MU105	8.74E-10	NO DATA	2.93E-10	NO DATA	6.42E-10	1.12E-05	3.46E-05
MU106	6.33E-05	NO DATA	7.77E-06	NO DATA	7.61E-05	8.26E-03	1.17E-04
AG110M	7.13E-06	5.16E-06	3.57E-06	NO DATA	7.80E-06	2.62E-03	2.36E-05
FE125M	3.40E-06	1.42E-06	4.70E-07	1.16E-06	NO DATA	3.19E-04	9.22E-06
FE127M	1.19E-05	4.93E-06	1.48E-06	3.48E-06	2.68E-05	9.37E-04	1.95E-05
FE127	1.59E-09	6.81E-10	3.47E-10	1.32E-09	3.47E-09	7.39E-06	1.74E-05
FE129M	1.01E-05	4.35E-06	1.57E-06	3.91E-06	2.27E-05	1.20E-03	4.93E-05
FE129	5.63E-11	2.48E-11	1.34E-11	4.82E-11	1.25E-10	2.14E-06	1.88E-05
FE131M	7.62E-05	3.93E-08	2.59E-08	6.38E-08	1.89E-07	1.42E-04	8.51E-05
FE131	1.24E-11	5.87E-12	3.57E-12	1.13E-11	2.85E-11	1.47E-06	5.87E-06
FE132	2.66E-07	1.69E-07	1.26E-07	1.99E-07	7.39E-07	2.43E-04	1.15E-05
I 130	4.54E-06	9.71E-06	3.98E-06	1.14E-03	1.79E-05	NO DATA	1.42E-06
I 131	2.71E-05	3.17E-05	1.40E-05	1.06E-02	3.70E-05	NO DATA	7.56E-07
I 132	1.71E-06	2.53E-06	8.99E-07	1.21E-04	2.92E-06	NO DATA	1.36E-06
I 133	9.46E-06	1.37E-05	4.00E-06	2.54E-03	1.60E-05	NO DATA	1.54E-06
I 134	6.58E-07	1.34E-06	4.75E-07	3.18E-05	1.49E-06	NO DATA	9.21E-07
I 135	2.74E-06	5.43E-06	1.98E-06	4.97E-04	6.05E-06	NO DATA	1.31E-06
CS134	2.83E-04	5.02E-04	5.32E-05	NO DATA	1.36E-04	5.69E-05	9.53E-07
CS134	3.45E-05	9.61E-05	3.78E-05	NO DATA	4.03E-05	8.40E-06	1.02E-06
CS137	3.92E-04	4.37E-04	3.25E-05	NO DATA	1.23E-04	5.09E-05	9.53E-07
CS138	3.61E-07	5.58E-07	2.84E-07	NO DATA	2.93E-07	4.67E-08	6.26E-07
BA139	1.04E-09	7.03E-13	3.07E-11	NO DATA	4.73E-13	4.25E-06	3.64E-05

TABLE E-10, CONT'D

PAGE 3 OF 3

INHALATION DOSE FACTORS FOR INFANT  
(MREM PER PCI INHALED)

MUCLICE	BONE	LIVER	T.BODY	THYROID	KIDNEY	LUNG	GI-LLI
BA140	4.00E-05	4.00E-08	2.07E-06	NO DATA	4.59E-09	1.14E-03	2.74E-05
PA141	1.12E-10	7.70E-14	3.55E-12	NO DATA	4.64E-14	2.12E-06	3.39E-06
PA142	2.84E-11	2.36E-14	1.40E-12	NO DATA	1.36E-14	1.11E-06	4.95E-07
LA140	3.61E-07	1.43E-07	3.68E-08	NO DATA	NO DATA	1.20E-04	6.76E-05
LA142	7.36E-10	2.69E-10	6.46E-11	NO DATA	NO DATA	5.87E-06	4.25E-05
CE141	1.98E-05	1.19E-05	1.42E-06	NO DATA	3.75E-06	3.69E-04	1.54E-05
CE143	2.09E-07	1.48E-07	1.54E-08	NO DATA	4.03E-08	8.30E-05	3.55E-05
CE144	2.28E-03	8.65E-04	1.26E-04	NO DATA	3.84E-04	7.03E-03	1.56E-04
PA143	1.00E-05	3.74E-06	4.99E-07	NO DATA	1.41E-06	3.09E-04	2.86E-05
PR144	3.42E-11	1.32E-11	1.72E-12	NO DATA	4.40E-12	1.15E-06	3.04E-06
NO147	5.67E-06	5.81E-06	3.57E-07	NO DATA	2.25E-06	3.30E-04	2.23E-05
W 187	9.26E-09	6.44E-09	2.23E-09	NO DATA	NO DATA	7.83E-05	2.54E-05
NP239	2.65E-07	2.37E-08	1.34E-08	NO DATA	4.73E-08	4.25E-05	1.78E-05

REG. GUIDE 1.109

TABLE F-11

PAGE 1 OF 3

INGESTION DOSE FACTORS FOR ADULTS  
(MREM PER PCI INGESTED)

NUCLIDE	BONE	LIVER	T.BODY	THYROID	KIDNEY	LUNG	GI-LLI
H 3	NO DATA	1.05E-07	1.05E-07	1.05E-07	1.05E-07	1.05E-07	1.05E-07
C 14	2.84E-06	5.68E-07	5.68E-07	5.68E-07	5.68E-07	5.68E-07	5.68E-07
Na 24	1.70E-06	1.70E-06	1.70E-06	1.70E-06	1.70E-06	1.70E-06	1.70E-06
P 32	1.93E-04	1.20E-05	7.46E-06	NO DATA	NO DATA	NO DATA	2.17E-05
CR 51	NO DATA	NO DATA	2.60E-09	1.59E-09	5.86E-10	3.53E-09	6.69E-07
MN 54	NO DATA	4.57E-06	8.72E-07	NO DATA	1.36E-06	NO DATA	1.40E-05
MN 56	NO DATA	1.15E-07	2.04E-08	NO DATA	1.46E-07	NO DATA	3.67E-06
FE 55	2.75E-06	1.90E-06	4.43E-07	NO DATA	NO DATA	1.06E-06	1.09E-06
FE 59	4.34E-06	1.02E-05	3.91E-06	NO DATA	NO DATA	2.85E-06	3.40E-05
CO 58	NO DATA	7.45E-07	1.67E-06	NO DATA	NO DATA	NO DATA	1.51E-05
CO 60	NO DATA	2.14E-06	4.72E-06	NO DATA	NO DATA	NO DATA	4.02E-05
NI 63	1.30E-04	9.01E-06	4.36E-04	NO DATA	NO DATA	NO DATA	1.88E-06
NI 65	5.28E-07	6.86E-08	3.13E-08	NO DATA	NO DATA	NO DATA	1.74E-06
CU 64	NO DATA	8.33E-08	3.91E-08	NO DATA	2.10E-07	NO DATA	7.10E-06
ZN 65	4.84E-06	1.94E-05	6.96E-06	NO DATA	1.03E-05	NO DATA	9.70E-06
ZN 69	1.03E-08	1.97E-08	1.37E-09	NO DATA	1.78E-08	NO DATA	2.96E-09
BR 83	NO DATA	NO DATA	4.02E-08	NO DATA	NO DATA	NO DATA	5.79E-08
BR 84	NO DATA	NO DATA	5.21E-08	NO DATA	NO DATA	NO DATA	4.09E-13
BR 85	NO DATA	NO DATA	2.14E-09	NO DATA	NO DATA	NO DATA	1.7 E-24
RB 86	NO DATA	2.11E-05	9.83E-06	NO DATA	NO DATA	NO DATA	4.16E-06
YB 88	NO DATA	6.05E-08	3.21E-08	NO DATA	NO DATA	NO DATA	8.36E-19
RB 98	NO DATA	4.01E-08	2.82E-08	NO DATA	NO DATA	NO DATA	2.33E-21
SR 87	3.08E-04	NO DATA	8.84E-06	NO DATA	NO DATA	NO DATA	4.94E-05
SR 90	7.58E-03	NO DATA	1.86E-03	NO DATA	NO DATA	NO DATA	2.19E-04
SR 91	5.67E-06	NO DATA	2.29E-07	NO DATA	NO DATA	NO DATA	2.70E-05
SR 92	2.15E-06	NO DATA	9.30E-08	NO DATA	NO DATA	NO DATA	4.26E-05
Y 90	9.62E-09	NO DATA	2.58E-10	NO DATA	NO DATA	NO DATA	1.02E-04
Y 91M	9.09E-11	NO DATA	3.52E-12	NO DATA	NO DATA	NO DATA	2.67E-10
Y 91	1.41E-07	NO DATA	3.77E-09	NO DATA	NO DATA	NO DATA	7.76E-05
Y 92	8.45E-10	NO DATA	2.47E-11	NO DATA	NO DATA	NO DATA	1.48E-05

TABLE E-11, CONT'D

PAGE 2 OF 3

INGESTION DOSE FACTORS FOR ADULTS  
(MREM PER PCI INGESTED)

NUCLIDE	BONE	LIVER	T.BODY	THYROID	KIDNEY	LUNG	GI-LLI
Y 93	2.68E-09	NO DATA	7.40E-11	NO DATA	NO DATA	NO DATA	8.50E-05
ZR 95	3.04E-08	7.75E-09	6.60E-09	NO DATA	1.53E-08	NO DATA	3.09E-05
ZR 97	1.68E-09	3.39E-10	1.55E-10	NO DATA	5.12E-10	NO DATA	1.05E-04
NR 95	6.22E-09	3.46E-09	1.86E-09	NO DATA	3.42E-09	NO DATA	2.10E-05
NO 99	NO DATA	4.31E-06	8.20E-07	NO DATA	9.76E-06	NO DATA	9.99E-06
TC 99M	2.47E-10	5.95E-10	6.89E-09	NO DATA	1.06E-08	3.42E-10	4.13E-07
TE101	2.54E-10	3.66E-10	3.59E-09	NO DATA	6.59E-09	1.87E-10	1.10E-21
RUI03	1.85E-07	NO DATA	7.97E-08	NO DATA	7.06E-07	NO DATA	2.16E-05
RUI05	1.54E-08	NO DATA	6.08E-09	NO DATA	1.99E-07	NO DATA	9.42E-06
RUI06	2.75E-06	NO DATA	3.48E-07	NO DATA	5.71E-06	NO DATA	1.78E-04
AG110M	1.60E-07	1.48E-07	8.79E-08	NO DATA	2.91E-07	NO DATA	6.04E-05
TE125M	2.69E-06	9.71E-07	3.53E-07	8.06E-07	1.09E-05	NO DATA	1.07E-05
TE127M	6.77E-06	2.42E-06	8.25E-07	1.73E-06	2.75E-05	NO DATA	2.27E-05
TE127	1.10E-07	3.95E-08	2.38E-08	8.15E-08	4.48E-07	NO DATA	8.68E-06
TE129M	1.15E-05	4.79E-06	1.82E-06	3.95E-06	4.80E-05	NO DATA	5.79E-05
TE129	3.14E-08	1.18E-08	7.65E-09	2.41E-08	1.32E-07	NO DATA	2.37E-08
TE131M	1.73E-06	8.46E-07	7.05E-07	1.34E-06	6.57E-06	NO DATA	6.40E-05
TE131	1.97E-08	8.23E-09	6.22E-09	1.62E-08	8.63E-08	NO DATA	2.79E-09
FR132	2.52E-06	1.63E-06	1.52E-06	1.80E-06	1.57E-05	NO DATA	7.71E-05
I 130	7.56E-07	2.21E-06	8.80E-07	1.69E-06	3.48E-06	NO DATA	1.52E-06
I 131	4.16E-06	5.95E-06	3.41E-06	1.95E-03	1.02E-05	NO DATA	1.57E-06
I 132	2.03E-07	5.43E-07	1.90E-07	1.90E-05	8.65E-07	NO DATA	1.02E-07
I 133	1.42E-06	2.47E-06	7.53E-07	3.63E-04	4.31E-06	NO DATA	2.22E-06
I 134	1.06E-07	2.89E-07	1.03E-07	4.99E-06	4.58E-07	NO DATA	2.51E-10
I 135	4.43E-07	1.16E-06	4.28E-07	7.65E-05	1.86E-06	NO DATA	1.31E-06
CS134	6.22E-05	1.48E-04	1.21E-04	NO DATA	4.79E-05	1.59E-05	2.57E-06
CS136	4.51E-06	2.57E-05	1.85E-05	NO DATA	1.43E-05	1.96E-06	2.92E-06
CS137	7.97E-05	1.09E-04	7.14E-05	NO DATA	3.70E-05	1.23E-05	2.11E-06
CS138	5.52E-08	1.09E-07	5.40E-08	NO DATA	8.01E-08	7.91E-09	4.65E-13
BAL39	9.70E-08	6.91E-11	2.84E-09	NO DATA	6.46E-11	3.92E-11	1.72E-07



REG. GUIDE 1.109

TABLE E-11, CONT'D

PAGE 3 OF 3

INGESTION DOSE FACTORS FOR ADULTS  
(MREM PER PCI INGESTED)

NUCLIDE	BONE	LIVER	T.BODY	THYROID	KIDNEY	LUNG	GI-LLI
SA140	2.03E-05	2.55E-08	1.33E-06	NO DATA	8.67E-09	1.46E-08	4.18E-05
PA141	4.71E-08	3.96E-11	1.59E-09	NO DATA	3.31E-11	2.02E-11	2.22E-17
RA142	2.13E-08	2.19E-11	1.34E-09	NO DATA	1.85E-11	1.24E-11	3.00E-24
LA140	2.50E-09	1.24E-09	4.33E-10	NO DATA	NO DATA	NO DATA	9.25E-05
LA142	1.29E-10	9.82E-11	1.45E-11	NO DATA	NO DATA	NO DATA	4.25E-07
CE141	9.36E-09	6.13E-09	7.19E-10	NO DATA	2.94E-09	NO DATA	2.42E-05
CE143	1.65E-07	1.22E-06	1.35E-10	NO DATA	5.37E-10	NO DATA	4.54E-05
CE144	4.48E-07	2.04E-07	2.62E-08	NO DATA	1.21E-07	NO DATA	1.64E-04
PR143	9.20E-09	3.69E-09	4.56E-10	NO DATA	2.13E-09	NO DATA	4.03E-05
PR144	3.01E-11	1.25E-11	1.54E-12	NO DATA	7.05E-12	NO DATA	4.33E-18
ND147	6.29E-09	7.27E-09	4.35E-10	NO DATA	4.25E-09	NO DATA	3.49E-05
N 147	1.03E-07	8.61E-08	3.01E-08	NO DATA	NO DATA	NO DATA	2.82E-05
HP239	1.19E-07	1.17E-10	4.49E-11	NO DATA	3.65E-10	NO DATA	2.40E-05

TABLE E-12

PAGE 1 OF 3

INGESTION DOSE FACTORS FOR TEENAGER  
(MREM PER PCI INGESTED)

NUCLIDE	BONE	LIVER	T.BODY	THYROID	KIDNEY	LUNG	GI-LLI
H 3	NO DATA	1.06E-07	1.06E-07	1.06E-07	1.06E-07	1.06E-07	1.06E-07
C 14	4.06E-06	8.12E-07	8.12E-07	8.12E-07	8.12E-07	8.12E-07	8.12E-07
NA 24	2.30E-06	2.30E-06	2.30E-06	2.30E-06	2.30E-06	2.30E-06	2.30E-06
P 32	2.76E-04	1.71E-05	1.07E-05	NO DATA	NO DATA	NO DATA	2.32E-05
CR 51	NO DATA	NO DATA	3.60E-09	2.00E-09	7.89E-10	5.14E-09	6.05E-07
FR 54	NO DATA	5.90E-06	1.17E-06	NO DATA	1.76E-06	NO DATA	1.21E-05
HN 56	NO DATA	1.58E-07	2.81E-08	NO DATA	2.00E-07	NO DATA	1.04E-05
FF 59	3.78E-06	2.68E-06	6.25E-07	NO DATA	NO DATA	1.70E-06	1.16E-06
FE 59	5.87E-06	1.27E-05	5.29E-06	NO DATA	NO DATA	4.32E-06	5.24E-05
CO 58	NO DATA	9.72E-07	2.24E-06	NO DATA	NO DATA	NO DATA	1.34E-05
CU 60	NO DATA	2.61E-06	6.33E-06	NO DATA	NO DATA	NO DATA	3.66E-05
NI 63	1.77E-04	1.25E-05	6.00E-06	NO DATA	NO DATA	NO DATA	1.99E-06
VI 65	7.49E-07	9.57E-08	4.36E-08	NO DATA	NO DATA	NO DATA	5.19E-06
CU 64	NO DATA	1.15E-07	5.41E-08	NO DATA	2.71E-07	NO DATA	8.42E-06
ZN 65	5.76E-06	2.00E-05	9.31E-06	NO DATA	1.28E-05	NO DATA	8.47E-06
ZN 67	1.47E-08	2.60E-08	1.96E-09	NO DATA	1.43E-08	NO DATA	5.16E-08
SR 83	NO DATA	NO DATA	5.74E-08	NO DATA	NO DATA	NO DATA	LT E-24
SR 84	NO DATA	NO DATA	7.22E-08	NO DATA	NO DATA	NO DATA	LT E-24
SR 85	NO DATA	NO DATA	3.05E-09	NO DATA	NO DATA	NO DATA	LT E-24
SR 86	NO DATA	2.98E-05	1.40E-05	NO DATA	NO DATA	NO DATA	4.41E-06
SR 88	NO DATA	8.52E-08	4.94E-08	NO DATA	NO DATA	NO DATA	7.30E-15
KB 89	NO DATA	5.30E-08	1.89E-08	NO DATA	NO DATA	NO DATA	8.43E-17
SC 87	4.40E-04	NO DATA	1.26E-05	NO DATA	NO DATA	NO DATA	5.24E-05
SR 90	8.30E-03	NO DATA	2.05E-03	NO DATA	NO DATA	NO DATA	2.33E-04
SR 91	8.07E-06	NO DATA	3.21E-07	NO DATA	NO DATA	NO DATA	7.66E-05
SR 92	3.05E-06	NO DATA	1.30E-07	NO DATA	NO DATA	NO DATA	1.77E-05
Y 90	1.37E-08	NO DATA	3.67E-10	NO DATA	NO DATA	NO DATA	1.13E-04
Y 91*	1.29E-10	NO DATA	4.93E-12	NO DATA	NO DATA	NO DATA	6.09E-09
Y 91	2.01E-07	NO DATA	5.39E-09	NO DATA	NO DATA	NO DATA	8.24E-05
Y 92	1.21E-09	NO DATA	3.50E-11	NO DATA	NO DATA	NO DATA	3.32E-05

REG. GUIDE 1.109

TABLE E-12, CONT'D

PAGE 2 OF 3

INGESTION DOSE FACTORS FOR TEENAGER  
(MREM PER PCI INGESTED)

NUCLIDE	BONE	LIVER	T.BODY	THYROID	KIDNEY	LUNG	GI-LLI
Y 93	3.83E-09	NO DATA	1.05E-10	NO DATA	NO DATA	NO DATA	1.17E-04
Zn 95	4.12E-08	1.30E-08	8.94E-09	NO DATA	1.91E-08	NO DATA	3.00E-05
Zr 97	2.37E-09	4.69E-10	2.16E-10	NO DATA	7.11E-10	NO DATA	1.27E-04
Am 95	8.22E-09	4.56E-09	2.51E-09	NO DATA	4.42E-09	NO DATA	1.95E-05
MO 97	NO DATA	6.03E-06	1.17E-06	NO DATA	1.38E-05	NO DATA	1.08E-05
TC 99#	1.32E-10	9.26E-10	1.20E-08	NO DATA	1.38E-08	5.14E-10	6.08E-07
TC101	3.60E-10	5.12E-10	5.03E-09	NO DATA	9.26E-09	3.12E-10	8.75E-17
MU103	2.55E-07	NO DATA	1.09E-07	NO DATA	8.99E-07	NO DATA	2.13E-05
MU105	2.18E-08	NO DATA	8.46E-09	NO DATA	2.75E-07	NO DATA	1.76E-05
RU106	3.72E-06	NO DATA	4.94E-07	NO DATA	7.56E-06	NO DATA	1.88E-04
AG110*	2.05E-07	1.94E-07	1.18E-07	NO DATA	3.70E-07	NO DATA	5.43E-05
TE125*	3.83E-06	1.38E-06	5.12E-07	1.07E-06	NO DATA	NO DATA	1.13E-05
TE127*	9.67E-06	3.43E-06	1.15E-06	2.30E-06	3.92E-05	NO DATA	2.41E-05
TE127	1.58E-07	5.60E-08	3.40E-08	1.09E-07	6.40E-07	NO DATA	1.22E-05
TE129*	1.63E-05	6.05E-06	2.58E-06	5.26E-06	6.42E-05	NO DATA	5.12E-05
TE129	4.48E-08	1.67E-08	1.03E-08	3.20E-08	1.88E-07	NO DATA	2.45E-07
TE131*	2.44E-06	1.17E-06	9.76E-07	1.76E-06	1.22E-05	NO DATA	9.39E-05
TE131	2.79E-08	1.15E-08	8.72E-09	2.15E-08	1.22E-07	NO DATA	2.89E-09
TE132	3.49E-06	2.21E-06	2.06E-06	2.33E-06	2.12E-05	NO DATA	7.00E-05
I 130	1.03E-06	2.98E-06	1.19E-05	2.43E-04	4.59E-06	NO DATA	2.29E-04
I 131	5.85E-06	8.19E-06	4.40E-06	2.39E-03	1.41E-05	NO DATA	1.62E-06
I 132	2.79E-07	7.30E-07	2.62E-07	2.46E-05	1.15E-06	NO DATA	3.18E-07
I 133	2.01E-06	3.41E-06	1.04E-06	4.76E-04	5.98E-06	NO DATA	2.58E-06
I 134	1.46E-07	3.87E-07	1.39E-07	6.45E-06	6.10E-07	NO DATA	5.10E-09
I 135	6.10E-07	1.57E-06	5.82E-07	1.01E-04	2.48E-06	NO DATA	1.74E-06
CS134	8.37E-05	1.97E-04	9.14E-05	NO DATA	6.26E-05	2.39E-05	2.45E-06
CS136	8.59E-06	3.28E-05	2.27E-05	NO DATA	1.84E-05	2.90E-06	2.72E-06
CS137	1.12E-04	1.49E-04	5.19E-05	NO DATA	5.07E-05	1.97E-05	2.12E-06
CS138	7.76E-08	1.49E-07	7.45E-08	NO DATA	1.10E-07	1.28E-08	6.76E-11
BA139	1.39E-07	9.78E-11	4.05E-09	NO DATA	9.22E-11	6.74E-11	1.24E-06

TABLE E-12, CONT'D

PAGE 3 OF 3

INGESTION DOSE FACTORS FOR TEENAGER  
(MREM PER PCI INGESTED)

NUCLIDE	BONE	LIVER	T.BODY	THYROID	KIDNEY	LUNG	GI-LLI
BA140	2.84E-05	3.48E-08	1.83E-06	NO DATA	1.18E-08	2.34E-08	4.38E-05
BA141	6.71E-09	5.71E-11	2.24E-09	NO DATA	4.65E-11	3.43E-11	1.43E-13
BA142	2.99E-08	2.99E-11	1.84E-09	NO DATA	2.53E-11	1.99E-11	9.18E-20
LA140	3.48E-09	1.71E-09	4.55E-10	NO DATA	NO DATA	NO DATA	9.82E-05
LA142	1.79E-10	7.95E-11	1.98E-11	NO DATA	NO DATA	NO DATA	2.42E-06
CE141	1.33E-08	8.68E-09	1.02E-09	NO DATA	4.18E-09	NO DATA	2.54E-05
CE143	2.35E-09	1.71E-06	1.91E-10	NO DATA	7.67E-10	NO DATA	5.14E-05
CF144	6.76E-07	2.88E-07	3.74E-08	NO DATA	1.72E-07	NO DATA	1.75E-04
PR143	1.31E-08	5.23E-09	6.52E-10	NO DATA	3.74E-09	NO DATA	4.31E-05
PR144	4.30E-11	1.76E-11	2.18E-12	NO DATA	1.01E-11	NO DATA	4.77E-14
ND147	9.38E-09	1.02E-08	6.11E-10	NO DATA	5.99E-09	NO DATA	3.68E-05
W 147	1.46E-07	1.19E-07	4.17E-08	NO DATA	NO DATA	NO DATA	3.22E-05
YR234	1.76E-09	1.66E-10	9.22E-11	NO DATA	5.21E-10	NO DATA	2.67E-05

REG. GUIDE 1.109

TABLE E-13

PAGE 1 OF 3

INGESTION DOSE FACTORS FOR CHILD  
(MREM PER PCI INGESTED)

NUCLIDE	BONE	LIVER	T.BODY	THYROID	KIDNEY	LUNG	GI-LLI
H 3	NO DATA	2.03E-07	2.03E-07	2.03E-07	2.03E-07	2.03E-07	2.03E-07
C 14	1.21E-05	2.42E-06	2.42E-06	2.42E-06	2.42E-06	2.42E-06	2.42E-06
NA 24	5.50E-06	5.80E-06	5.80E-06	5.80E-06	5.80E-06	5.80E-06	5.80E-06
P 32	8.75E-04	3.86E-03	3.10E-03	NO DATA	NO DATA	NO DATA	2.28E-05
CR 51	NO DATA	NO DATA	8.90E-09	4.94E-09	1.35E-09	9.02E-09	4.72E-07
MN 54	NO DATA	1.07E-05	2.85E-06	NO DATA	3.00E-06	NO DATA	8.98E-06
MN 56	NO DATA	3.34E-07	7.54E-08	NO DATA	4.04E-07	NO DATA	4.84E-05
FE 55	1.15E-05	6.10E-06	1.89E-06	NO DATA	NO DATA	3.45E-06	1.13E-06
FE 59	1.65E-05	7.67E-05	1.33E-05	NO DATA	NO DATA	7.74E-06	2.78E-05
CO 58	NO DATA	1.80E-06	3.51E-06	NO DATA	NO DATA	NO DATA	1.05E-05
CO 60	NO DATA	5.29E-06	1.56E-05	NO DATA	NO DATA	NO DATA	2.93E-05
NI 63	5.38E-04	2.08E-05	1.83E-05	NO DATA	NO DATA	NO DATA	1.94E-06
NI 65	2.22E-06	7.09E-07	1.22E-07	NO DATA	NO DATA	NO DATA	7.56E-05
CU 64	NO DATA	2.45E-07	1.48E-07	NO DATA	3.92E-07	NO DATA	1.15E-05
ZN 65	1.37E-05	3.65E-05	2.27E-05	NO DATA	2.30E-05	NO DATA	6.41E-06
ZN 69	4.38E-08	6.33E-08	5.85E-09	NO DATA	3.84E-08	NO DATA	3.99E-06
BR 81	NO DATA	NO DATA	1.71E-07	NO DATA	NO DATA	NO DATA	LT E-24
BR 84	NO DATA	NO DATA	1.99E-07	NO DATA	NO DATA	NO DATA	LT E-24
RR 85	NO DATA	NO DATA	9.12E-09	NO DATA	NO DATA	NO DATA	LT E-24
RB 86	NO DATA	6.70E-05	4.12E-05	NO DATA	NO DATA	NO DATA	4.31E-06
RB 88	NO DATA	1.90E-07	1.32E-07	NO DATA	NO DATA	NO DATA	9.32E-09
RH 89	NO DATA	1.17E-07	1.04E-07	NO DATA	NO DATA	NO DATA	1.02E-09
SR 87	1.32E-03	NO DATA	3.77E-05	NO DATA	NO DATA	NO DATA	5.11E-05
SR 90	1.70E-02	NO DATA	4.31E-04	NO DATA	NO DATA	NO DATA	2.79E-04
SR 91	2.40E-05	NO DATA	9.06E-07	NO DATA	NO DATA	NO DATA	5.30E-05
SR 92	4.03E-06	NO DATA	3.62E-07	NO DATA	NO DATA	NO DATA	1.71E-04
Y 90	4.11E-08	NO DATA	1.10E-09	NO DATA	NO DATA	NO DATA	1.17E-04
Y 91*	3.82E-10	NO DATA	1.37E-11	NO DATA	NO DATA	NO DATA	7.48E-07
Y 91	6.02E-07	NO DATA	1.61E-08	NO DATA	NO DATA	NO DATA	6.02E-05
Y 92	3.60E-09	NO DATA	1.03E-10	NO DATA	NO DATA	NO DATA	1.04E-04

TABLE E-13, CONT'D

PAGE 2 OF 3

INGESTION DOSE FACTORS FOR CHILD  
(MREM PER PCI INGESTED)

NUCLIDE	BONE	LIVER	T.BODY	THYROID	KIDNEY	LUNG	GI-LLI
Y 92	1.14E-08	NO DATA	3.13E-10	NO DATA	NO DATA	NO DATA	1.70E-04
ZR 95	1.16E-07	2.95E-08	2.27E-08	NO DATA	3.65E-08	NO DATA	2.66E-05
ZR 97	6.99E-09	1.01E-09	9.96E-10	NO DATA	1.45E-09	NO DATA	1.93E-04
NA 95	2.25E-08	8.76E-09	6.26E-09	NO DATA	8.23E-09	NO DATA	1.62E-05
NO 99	NO DATA	1.33E-05	3.29E-06	NO DATA	2.84E-05	NO DATA	1.10E-05
TC 99*	9.23E-10	1.81E-09	3.00E-08	NO DATA	2.63E-08	4.19E-10	1.03E-06
TC101	1.07E-04	1.12E-09	1.42E-08	NO DATA	1.91E-08	5.92E-10	3.66E-04
RU103	7.31E-07	NO DATA	2.81E-07	NO DATA	1.84E-06	NO DATA	1.89E-05
RU105	6.45E-08	NO DATA	2.34E-08	NO DATA	5.67E-07	NO DATA	4.21E-05
RU106	1.17E-05	NO DATA	1.44E-06	NO DATA	1.58E-05	NO DATA	1.82E-04
AG110M	3.39E-07	3.64E-07	2.91E-07	NO DATA	6.78E-07	NO DATA	4.33E-05
TE125*	1.14E-05	3.09E-06	1.52E-06	3.20E-06	NO DATA	NO DATA	1.10E-05
TE127*	2.89E-05	7.78E-06	3.43E-06	6.91E-06	8.24E-05	NO DATA	2.34E-05
TE127	4.71E-07	1.27E-07	1.01E-07	3.26E-07	1.94E-06	NO DATA	1.84E-05
TE129*	4.87E-05	1.36E-05	7.56E-06	1.57E-05	1.43E-04	NO DATA	5.94E-05
TE129	1.34E-07	3.74E-08	3.18E-08	9.56E-08	3.92E-07	NO DATA	4.34E-06
TE131*	7.20E-06	2.49E-06	2.65E-06	5.12E-06	2.41E-05	NO DATA	1.01E-04
TE131	8.30E-08	2.53E-08	2.47E-08	6.35E-08	2.51E-07	NO DATA	4.36E-07
TE132	1.01E-05	4.47E-06	5.40E-06	6.51E-06	4.15E-05	NO DATA	4.90E-05
I 130	2.92E-06	5.90E-06	3.04E-06	4.50E-06	8.82E-06	NO DATA	2.76E-06
I 131	1.72E-05	1.73E-05	9.84E-06	5.72E-05	2.84E-05	NO DATA	1.54E-04
I 132	8.00E-07	1.47E-06	6.76E-07	6.82E-05	2.25E-06	NO DATA	1.73E-06
I 133	5.92E-06	7.32E-06	2.77E-06	1.36E-05	1.22E-05	NO DATA	2.95E-06
I 134	4.19E-07	7.78E-07	3.58E-07	1.79E-05	1.19E-06	NO DATA	5.16E-07
I 135	1.75E-04	3.15E-06	1.49E-06	2.79E-04	4.83E-06	NO DATA	2.40E-04
CS134	2.14E-04	3.84E-04	8.10E-05	NO DATA	1.19E-04	4.27E-05	2.07E-06
CS136	2.35E-05	6.46E-05	4.18E-05	NO DATA	3.44E-05	5.13E-06	2.27E-06
CS137	3.27E-04	3.13E-04	4.62E-05	NO DATA	1.02E-04	3.67E-05	1.96E-06
CS138	2.28E-07	3.17E-07	2.01E-07	NO DATA	2.23E-07	2.40E-08	1.46E-07
BA139	4.14E-07	2.21E-10	1.20E-08	NO DATA	1.93E-10	1.30E-10	2.39E-05

REG. GUIDE 1.109

TABLE E-13, CONT'D

PAGE 3 OF 3

INJECTION DOSE FACTORS FOR CHILD  
(MREM PER MCI INGESTED)

NUCLIDE	BONE	LIVER	T.BODY	THYROID	KIDNEY	LUNG	GI-LLI
PA140	8.31E-05	7.78E-08	4.80E-06	NO DATA	2.37E-08	4.34E-08	4.21E-05
PA141	2.00E-07	1.12E-10	6.51E-09	NO DATA	9.69E-11	6.58E-10	1.14E-07
PA142	8.74E-08	6.29E-11	4.88E-09	NO DATA	5.09E-11	3.70E-11	1.14E-09
LA140	1.01E-09	3.53E-09	1.17E-09	NO DATA	NO DATA	NO DATA	9.84E-05
LA142	5.74E-10	1.67E-10	5.23E-11	NO DATA	NO DATA	NO DATA	3.31E-05
CE141	3.97E-08	1.98E-08	2.94E-09	NO DATA	8.68E-09	NO DATA	2.47E-05
CE143	6.99E-09	3.79E-06	5.49E-10	NO DATA	1.59E-09	NO DATA	5.55E-05
CE144	2.08E-06	6.52E-07	1.11E-07	NO DATA	3.61E-07	NO DATA	1.70E-04
PR143	3.93E-08	1.18E-08	1.95E-09	NO DATA	6.19E-09	NO DATA	4.24E-05
PR144	1.29E-10	3.37E-11	6.49E-12	NO DATA	2.11E-11	NO DATA	8.59E-08
ND147	2.79E-04	2.26E-08	1.75E-09	NO DATA	1.24E-08	NO DATA	3.58E-05
H 187	4.29E-07	2.54E-07	1.14E-07	NO DATA	NO DATA	NO DATA	3.57E-05
JK239	5.75E-09	3.77E-10	2.65E-10	NO DATA	1.09E-09	NO DATA	2.79E-05

TABLE E-14

PAGE 1 OF 3

INGESTION DOSE FACTORS FOR INFANT  
(MREM PER MCI INGESTED)

NUCLIDE	BONE	LIVER	T.BODY	THYROID	KIDNEY	LUNG	GI-LLI
H 3	NO DATA	3.08E-07	3.08E-07	3.08E-07	3.08E-07	3.08E-07	3.08E-07
L 14	2.37E-05	5.06E-06	5.06E-06	5.06E-06	5.06E-06	5.06E-06	5.06E-06
NA 24	1.01E-05	1.01E-05	1.01E-05	1.01E-05	1.01E-05	1.01E-05	1.01E-05
P 32	1.70E-03	1.00E-04	6.59E-05	NO DATA	NO DATA	NO DATA	2.10E-05
SA 51	NO DATA	NO DATA	1.41E-08	3.20E-09	2.01E-09	1.79E-08	4.11E-07
SN 54	NO DATA	1.99E-05	4.51E-06	NO DATA	4.41E-06	NO DATA	7.31E-06
HN 56	NO DATA	8.18E-07	1.41E-07	NO DATA	7.03E-07	NO DATA	7.43E-05
FE 55	1.39E-05	8.98E-06	2.40E-06	NO DATA	NO DATA	4.39E-06	1.14E-06
FF 59	3.08E-05	5.38E-05	2.12E-05	NO DATA	NO DATA	1.59E-05	2.57E-05
CO 58	NO DATA	3.60E-06	8.95E-06	NO DATA	NO DATA	NO DATA	8.97E-06
CC 60	NO DATA	1.08E-05	2.55E-05	NO DATA	NO DATA	NO DATA	2.57E-05
NI 63	6.34E-04	3.92E-05	2.20E-05	NO DATA	NO DATA	NO DATA	1.95E-06
YI 65	4.70E-06	5.32E-07	2.42E-07	NO DATA	NO DATA	NO DATA	4.05E-05
LU 64	NO DATA	6.09E-07	2.82E-07	NO DATA	1.03E-06	NO DATA	1.25E-05
ZN 65	1.54E-05	6.21E-05	2.91E-05	NO DATA	3.06E-05	NO DATA	5.33E-05
ZN 69	9.33E-08	1.68E-07	1.25E-08	NO DATA	6.98E-08	NO DATA	1.37E-05
HR 83	NO DATA	NO DATA	3.63E-07	NO DATA	NO DATA	NO DATA	LT E-24
HR 84	NO DATA	NO DATA	3.82E-07	NO DATA	NO DATA	NO DATA	LT E-24
HR 85	NO DATA	NO DATA	1.74E-08	NO DATA	NO DATA	NO DATA	LT E-24
HO 86	NO DATA	1.70E-04	8.40E-05	NO DATA	NO DATA	NO DATA	4.35E-06
KB 88	NO DATA	4.98E-07	2.73E-07	NO DATA	NO DATA	NO DATA	4.85E-07
RE 89	NO DATA	2.86E-07	1.97E-07	NO DATA	NO DATA	NO DATA	9.74E-08
SR 89	2.51E-03	NO DATA	7.20E-05	NO DATA	NO DATA	NO DATA	5.16E-05
SR 90	1.85E-02	NO DATA	4.71E-03	NO DATA	NO DATA	NO DATA	2.31E-04
SR 91	5.00E-05	NO DATA	1.81E-06	NO DATA	NO DATA	NO DATA	5.92E-05
SR 92	1.92E-05	NO DATA	7.13E-07	NO DATA	NO DATA	NO DATA	2.07E-04
Y 90	8.69E-08	NO DATA	2.32E-09	NO DATA	NO DATA	NO DATA	1.20E-04
Y 91a	8.10E-10	NO DATA	2.76E-11	NO DATA	NO DATA	NO DATA	2.70E-06
Y 91	1.13E-06	NO DATA	3.01E-08	NO DATA	NO DATA	NO DATA	8.10E-05
Y 92	7.65E-09	NO DATA	2.15E-10	NO DATA	NO DATA	NO DATA	1.46E-04

REG. GUIDE 1.109

TABLE E-14, CONT'D

PAGE 2 OF 3

INGESTION USE FACTORS FOR INFANT  
(MREM PER PCI INGESTED)

NUCLIDE	BONE	LIVER	T.BODY	THYROID	KIDNEY	LUNG	GI-LLI
Y 93	2.43E-08	NO DATA	6.62E-10	NO DATA	NO DATA	NO DATA	1.92E-04
Zr 95	2.06E-07	5.02E-08	3.56E-08	NO DATA	5.41E-08	NO DATA	2.50E-05
Zr 97	1.48E-08	2.54E-09	1.16E-09	NO DATA	2.56E-09	NO DATA	1.62E-04
Nb 95	4.20E-08	1.73E-08	1.02E-08	NO DATA	1.74E-08	NO DATA	1.46E-05
Mo 99	NO DATA	3.42E-05	6.63E-06	NO DATA	5.08E-05	NO DATA	1.12E-05
Tc 99m	1.92E-09	3.96E-09	5.10E-09	NO DATA	4.26E-08	2.07E-09	1.15E-06
Tc101	2.27E-09	2.96E-09	2.83E-08	NO DATA	3.40E-08	1.56E-09	4.86E-07
Ru103	1.48E-06	NO DATA	4.95E-07	NO DATA	3.08E-06	NO DATA	1.80E-05
Ru105	1.36E-07	NO DATA	4.58E-08	NO DATA	1.00E-06	NO DATA	5.41E-05
Ru106	2.41E-05	NO DATA	3.01E-06	NO DATA	2.85E-05	NO DATA	1.83E-04
Ag110m	9.96E-07	7.27E-07	4.81E-07	NO DATA	1.04E-06	NO DATA	3.77E-05
Tc125m	2.33E-05	7.79E-06	3.15E-06	7.84E-06	NO DATA	NO DATA	1.11E-05
Te127m	5.85E-05	1.94E-05	7.08E-06	1.69E-05	1.44E-04	NO DATA	2.36E-05
Te127	1.00E-06	3.35E-07	2.15E-07	8.14E-07	2.44E-06	NO DATA	2.10E-05
Te129m	1.00E-04	3.43E-05	1.54E-05	3.84E-05	2.50E-04	NO DATA	5.97E-05
Tc129	2.84E-07	9.79E-08	6.63E-08	2.38E-07	7.07E-07	NO DATA	2.27E-05
Te131m	1.52E-05	6.12E-06	5.05E-06	1.24E-05	4.21E-05	NO DATA	1.03E-04
Te131	1.76E-07	6.50E-08	4.94E-08	1.57E-07	4.50E-07	NO DATA	7.11E-06
Te132	2.08E-05	1.03E-05	9.61E-06	1.52E-05	6.44E-05	NO DATA	3.81E-05
I 135	6.00E-06	1.32E-05	5.37E-06	1.48E-03	1.45E-05	NO DATA	2.83E-06
I 131	3.59E-05	4.23E-05	1.46E-04	1.39E-02	4.94E-05	NO DATA	1.51E-06
I 132	1.66E-06	3.37E-06	1.20E-06	1.58E-04	3.76E-06	NO DATA	2.73E-06
I 133	1.25E-05	1.82E-05	5.33E-06	3.31E-03	2.14E-05	NO DATA	3.08E-06
I 134	8.69E-07	1.78E-06	6.33E-07	4.15E-05	1.99E-06	NO DATA	1.84E-06
I 135	3.44E-06	7.24E-06	2.64E-06	6.49E-04	9.07E-06	NO DATA	2.62E-06
Cs134	3.77E-04	7.03E-04	7.10E-05	NO DATA	1.81E-04	7.42E-05	1.91E-06
Cs136	4.59E-05	1.35E-04	5.04E-05	NO DATA	5.98E-05	1.10E-05	2.05E-06
Cs137	5.22E-04	6.11E-04	4.13E-05	NO DATA	1.64E-04	6.64E-05	1.91E-06
Cs138	4.81E-07	7.62E-07	3.79E-07	NO DATA	3.90E-07	6.09E-08	1.25E-06
Ba139	8.81E-07	5.84E-10	2.55E-08	NO DATA	3.51E-10	3.54E-10	5.58E-05

TABLE E-14, CONT'D

PAGE 3 OF 3

INGESTION USE FACTORS FOR INFANT  
(MREM PER PCI INGESTED)

NUCLIDE	BONE	LIVER	T.BODY	THYROID	KIDNEY	LUNG	GI-LLI
Ba140	1.71E-04	1.71E-07	5.81E-06	NO DATA	4.06E-08	1.05E-07	4.20E-05
Ba141	4.25E-07	2.91E-10	1.34E-08	NO DATA	1.75E-10	1.77E-10	5.19E-06
Ba142	1.94E-07	1.53E-10	9.06E-09	NO DATA	3.81E-11	9.26E-11	7.59E-07
La140	2.11E-08	8.32E-09	2.17E-09	NO DATA	NO DATA	NO DATA	9.77E-05
La142	1.10E-09	4.04E-10	9.67E-11	NO DATA	NO DATA	NO DATA	6.86E-05
Ce141	7.67E-08	4.80E-08	5.65E-09	NO DATA	1.48E-08	NO DATA	2.48E-05
Ce143	1.48E-08	9.82E-06	1.17E-09	NO DATA	7.56E-09	NO DATA	5.73E-05
Ce144	2.98E-06	1.22E-06	1.67E-07	NO DATA	4.93E-07	NO DATA	1.71E-04
Pr143	8.13E-08	3.04E-08	4.03E-09	NO DATA	1.13E-08	NO DATA	4.29E-05
Pr144	2.74E-10	1.06E-10	1.38E-11	NO DATA	5.64E-11	NO DATA	4.93E-06
Nd147	5.53E-08	3.68E-08	3.48E-09	NO DATA	2.19E-08	NO DATA	3.60E-05
Sm 147	9.73E-07	6.26E-07	2.17E-07	NO DATA	NO DATA	NO DATA	3.69E-05
Np237	1.11E-09	9.93E-10	5.81E-10	NO DATA	1.78E-09	NO DATA	2.87E-05





TABLE 2 (cont'd)  
Page 2 of 4

ISOTOPE	COMMITMENT FACTORS(MEM)/ADV PER PCI INGESTED IN FIRST YR							GI-LLI
	BONE	LIVER	TOTAL BODY	THYROID	KIDNEY	LUNG	GI-LLI	
W3	0.	2.03E-07	2.03E-07	2.03E-07	2.03E-07	2.03E-07	0.	1.17E-04
W10	1.75E-05	1.57E-06	3.39E-07	0.	1.11E-06	0.	0.	7.48E-07
C14	1.21E-05	2.27E-06	2.47E-06	2.42E-06	2.42E-06	2.42E-06	0.	8.02E-05
P13	3.10E-08	3.10E-08	3.10E-08	3.10E-08	3.10E-08	3.10E-08	0.	1.04E-04
F18	2.69E-08	2.67E-07	0.	0.	6.76E-07	0.	0.	1.70E-04
W22	5.88E-05	5.88E-05	5.88E-05	5.88E-05	5.88E-05	5.88E-05	0.	2.37E-05
W26	5.80E-06	5.80E-06	5.80E-06	5.80E-06	5.80E-06	5.80E-06	0.	2.66E-05
P32	8.75E-04	3.86E-05	3.18E-05	0.	0.	0.	0.	1.53E-04
W39	0.	0.	0.	0.	0.	0.	0.	1.62E-05
W41	3.48E-04	3.79E-05	0.	0.	0.	0.	0.	1.21E-05
C44	1.97E-08	1.94E-08	0.	0.	2.39E-08	0.	0.	1.27E-06
C51	0.	8.97E-09	6.94E-09	1.35E-09	1.35E-09	9.02E-09	0.	1.01E-05
W54	0.	1.67E-05	2.85E-06	0.	4.00E-07	0.	0.	2.84E-05
W56	0.	3.34E-07	7.54E-08	0.	0.	0.	0.	1.03E-05
F55	1.15E-05	6.10E-06	1.89E-06	0.	3.45E-06	0.	0.	6.25E-06
F59	1.65E-05	2.67E-05	1.33E-05	0.	7.74E-06	0.	0.	3.56E-09
C67	0.	4.93E-07	9.94E-07	0.	0.	0.	0.	1.89E-05
C68	0.	1.80E-06	5.51E-06	0.	0.	0.	0.	4.21E-05
C69	0.	5.29E-06	1.58E-05	0.	0.	0.	0.	1.82E-04
W19	5.02E-05	1.07E-05	6.82E-06	0.	0.	0.	0.	1.71E-05
W16	5.38E-04	2.88E-05	1.83E-05	0.	0.	0.	0.	3.35E-05
W15	2.27E-06	2.94E-07	1.27E-07	0.	5.92E-07	0.	0.	4.75E-05
C84	0.	2.45E-07	1.68E-07	0.	0.	0.	0.	2.63E-05
W65	1.37E-05	3.65E-05	2.27E-05	0.	2.30E-05	0.	0.	2.61E-05
W69	7.10E-07	1.21E-06	1.43E-07	0.	7.67E-07	0.	0.	6.52E-05
W79	6.38E-08	4.33E-08	5.85E-09	0.	3.84E-08	0.	0.	4.60E-07
W82	0.	8.43E-06	1.87E-06	0.	1.37E-05	0.	0.	1.10E-05
W83	0.	0.	7.55E-06	0.	0.	0.	0.	6.94E-05
W84	0.	0.	1.71E-07	0.	0.	0.	0.	1.10E-04
W85	0.	0.	1.98E-07	0.	0.	0.	0.	6.94E-05
W86	0.	0.	9.17E-09	0.	0.	0.	0.	1.71E-05
W87	0.	0.	0.	0.	0.	0.	0.	2.10E-06
W88	0.	0.	0.	0.	0.	0.	0.	4.60E-07
W89	0.	0.	0.	0.	0.	0.	0.	1.10E-05
W90	0.	0.	0.	0.	0.	0.	0.	2.34E-05
W91	0.	0.	0.	0.	0.	0.	0.	1.84E-05
W92	0.	0.	0.	0.	0.	0.	0.	5.94E-05
W93	0.	0.	0.	0.	0.	0.	0.	1.10E-04
W94	0.	0.	0.	0.	0.	0.	0.	4.50E-05
W95	0.	0.	0.	0.	0.	0.	0.	5.77E-06
W96	0.	0.	0.	0.	0.	0.	0.	5.89E-07
W97	0.	0.	0.	0.	0.	0.	0.	2.76E-07
W98	0.	0.	0.	0.	0.	0.	0.	2.76E-05
W99	0.	0.	0.	0.	0.	0.	0.	1.54E-06
W100	0.	0.	0.	0.	0.	0.	0.	0.

TABLE 2  
Page 1 of 4



TABLE 2 (cont'd)  
Page 3 of 4

CHILD INGESTION DOSE		COMMITMENT FACTORS (MREM/SY) PER PCI INGESTED IN FIRST YR				CHILD INGESTION DOSE		COMMITMENT FACTORS (MREM/SY) PER PCI INGESTED IN FIRST YR					
ISOTOPE	90DE	LIVER	TOTAL BODY	KIDNEY	LUNG	GI-LLI	ISOTOPE	90DE	LIVER	TOTAL BODY	KIDNEY	LUNG	GI-LLI
1132	8.00E-07	1.47E-06	6.76E-07	6.82E-05	2.25E-06	0.	99210+D	4.75E-02	1.22E-02	2.00E-03	0.	0.	5.17E-05
1133	5.92E-06	7.32E-06	7.77E-06	1.36E-03	1.22E-05	0.	81210+D	1.97E-06	1.62E-05	1.64E-07	0.	0.	5.17E-05
1134	5.19E-07	7.78E-07	3.58E-07	1.79E-09	1.19E-06	0.	90210	1.52E-03	2.43E-03	3.67E-04	0.	0.	6.55E-05
1135-U	1.75E-06	3.15E-06	1.69E-06	2.79E-04	4.93E-06	0.	08222+D	0.	0.	0.	0.	0.	0.
1133a	0.	0.	0.	0.	0.	0.	08223+D	7.12E-02	2.45E-05	4.74E-03	0.	0.	3.34E-04
1133b	0.	0.	0.	0.	0.	0.	08226+D	5.84E-03	1.24E-05	1.34E-03	0.	0.	3.74E-04
1133c	0.	0.	0.	0.	0.	0.	08227+D	2.80E-02	2.50E-05	5.50E-03	0.	0.	3.21E-04
1133d	0.	0.	0.	0.	0.	0.	08228+D	3.75E-01	3.04E-05	4.77E-01	0.	0.	3.61E-04
1133e	0.	0.	0.	0.	0.	0.	AC225	1.04E-05	1.94E-05	1.24E-06	0.	0.	5.81E-05
1133f	0.	0.	0.	0.	0.	0.	AC227+D	4.12E-03	6.63E-04	2.54E-04	0.	0.	8.43E-05
1133g	0.	0.	0.	0.	0.	0.	10227+D	5.85E-05	7.96E-07	1.65E-06	0.	0.	5.63E-04
1133h	8.44E-08	1.25E-07	6.16E-08	0.	6.59E-08	1.58E-07	10229+D	2.07E-03	2.65E-05	7.00E-05	0.	0.	5.79E-04
1133i	2.34E-04	3.84E-04	1.0E-05	0.	1.19E-04	2.07E-06	10230+D	1.39E-02	1.61E-04	6.80E-04	0.	0.	5.27E-04
1133j	8.30E-05	5.78E-05	5.93E-06	0.	2.04E-05	4.33E-07	10231+D	3.55E-03	1.78E-04	9.91E-05	0.	0.	6.19E-05
1133k	2.34E-05	6.44E-05	4.18E-05	0.	3.44E-05	5.13E-06	10232+D	3.96E-03	1.52E-04	3.61E-04	0.	0.	5.27E-05
1133l	3.27E-04	3.13E-04	6.62E-05	0.	1.02E-04	1.94E-06	10233+D	3.96E-03	1.52E-04	3.61E-04	0.	0.	5.27E-05
1133m	2.28E-07	3.17E-07	2.01E-07	0.	2.23E-07	1.44E-07	10234	7.42E-07	1.51E-08	9.66E-09	0.	0.	1.4E-04
1133n	1.45E-07	1.61E-07	7.64E-08	0.	1.21E-07	1.22E-08	08233+D	1.01E-08	2.82E-09	3.16E-09	0.	0.	1.44E-05
1133o	8.31E-05	7.28E-05	1.20E-06	0.	1.93E-10	2.39E-05	0233+D	1.76E-02	0.	2.24E-03	0.	0.	6.98E-05
1133p	2.06E-07	1.12E-07	6.51E-09	0.	2.37E-08	4.21E-05	0234	3.57E-03	0.	2.21E-04	0.	0.	6.32E-05
1133q	6.74E-06	6.26E-11	4.88E-09	0.	5.09E-11	1.14E-09	0235+D	3.2E-03	0.	2.07E-04	0.	0.	8.03E-05
1133r	1.01E-08	3.53E-09	1.19E-09	0.	0.	9.84E-05	0236	3.62E-03	0.	2.12E-04	0.	0.	5.73E-04
1133s	1.36E-09	3.17E-10	4.86E-11	0.	0.	7.05E-05	0237	2.86E-07	0.	6.27E-08	0.	0.	2.08E-05
1133t	5.24E-10	1.67E-10	5.23E-11	0.	0.	3.31E-05	0238+D	2.36E-03	1.81E-04	1.94E-04	0.	0.	5.64E-05
1133u	3.97E-08	1.98E-08	2.94E-09	0.	1.59E-09	5.55E-05	0239+D	5.43E-06	1.18E-09	9.79E-05	0.	0.	8.14E-05
1133v	6.94E-09	3.79E-09	5.49E-10	0.	3.61E-09	1.70E-04	0240	5.25E-09	3.77E-10	2.65E-10	0.	0.	2.79E-05
1133w	2.04E-06	6.52E-07	1.11E-07	0.	6.39E-09	4.24E-05	0241+D	1.25E-03	1.56E-04	3.14E-05	0.	0.	7.50E-05
1133x	3.93E-08	1.82E-06	1.95E-09	0.	2.11E-11	8.59E-08	0242+D	1.36E-03	1.65E-04	3.31E-05	0.	0.	6.85E-05
1133y	1.29E-10	3.94E-11	6.99E-12	0.	1.24E-08	3.58E-05	0243+D	4.80E-05	1.72E-06	8.04E-07	0.	0.	1.44E-06
1133z	3.14E-07	2.27E-08	1.22E-08	0.	3.64E-09	5.78E-05	0244+D	1.26E-03	1.90E-04	3.19E-05	0.	0.	6.71E-05
1133aa	1.03E-07	2.05E-08	2.05E-08	0.	6.17E-09	9.70E-05	0245	1.7E-03	1.82E-04	3.65E-05	0.	0.	1.00E-04
1133ab	3.02E-08	6.83E-09	2.35E-09	0.	1.22E-09	4.71E-05	0246	1.3E-03	6.08E-04	1.02E-04	0.	0.	7.64E-05
1133ac	6.49E-09	6.90E-10	2.74E-10	0.	6.02E-10	4.03E-05	0247	1.7E-03	1.04E-04	1.04E-04	0.	0.	9.95E-05
1133ad	2.97E-09	3.55E-10	2.31E-10	0.	3.94E-08	5.53E-06	0248	1.1E-03	6.54E-04	9.43E-05	0.	0.	8.14E-05
1133ae	2.56E-09	2.81E-09	1.20E-08	0.	6.91E-10	1.84E-05	0249	9.01E-03	8.84E-06	8.24E-05	0.	0.	8.03E-05
1133af	6.13E-07	1.12E-07	1.33E-07	0.	9.09E-07	8.61E-05	0250	1.11E-03	5.36E-04	6.93E-05	0.	0.	7.74E-05
1133ag	2.30E-06	2.07E-07	1.89E-07	0.	1.32E-07	8.69E-05	0251	1.76E-03	6.64E-04	1.95E-04	0.	0.	7.11E-05
1133ah	5.82E-08	3.81E-08	6.23E-09	0.	1.94E-08	3.68E-05	0252	1.74E-03	6.64E-04	1.95E-04	0.	0.	7.11E-05
1133ai	1.08E-08	2.24E-07	1.91E-07	0.	3.22E-07	0.	0253	1.01E-02	6.38E-04	1.63E-04	0.	0.	9.35E-05
1133aj	6.23E-08	1.43E-08	1.63E-09	0.	0.	1.63E-05	0254	1.01E-02	6.38E-04	1.63E-04	0.	0.	1.51E-03
1133ak	1.73E-08	4.32E-07	6.05E-08	0.	0.	3.57E-05	0255	1.07E-03	2.54E-05	0.	0.	2.04E-04	
1133al	4.24E-07	2.54E-07	1.14E-07	0.	0.	0.	0256	1.07E-03	2.54E-05	0.	0.	0.	

TABLE 3 (contd)  
Page 2 of 4

TEEN INGESTION DOSE COMMITMENT FACTORS(MRHM/SOY PER PCI INGESTED IN FIRST YR)				TEEN INGESTION DOSE COMMITMENT FACTORS(MRHM/SOY PER PCI INGESTED IN FIRST YR)			
ISOTOPE	BONE	LIVER	TOTAL BODY	ISOTOPE	BONE	LIVER	TOTAL BODY
M3	7.49E-06	1.06E-07	1.06E-07	Y90	1.37E-08	0.	3.59E-10
BE10	4.49E-06	9.94E-07	1.13E-07	Y91M-D	1.29E-10	0.	4.93E-12
Cl4	8.04E-06	6.12E-07	8.12E-07	Y91	2.01E-07	0.	5.39E-09
M13	1.15E-06	1.15E-06	1.15E-06	Y92	1.21E-09	0.	3.50E-11
F16	8.64E-07	9.47E-06	9.47E-06	Y93	3.83E-09	0.	1.05E-10
M22	2.34E-05	2.34E-05	2.34E-05	Z993-D	5.53E-08	2.73E-05	9.65E-08
M24	2.30E-06	2.30E-06	2.30E-06	Z994-D	4.12E-08	1.30E-08	1.91E-08
P32	2.76E-04	1.71E-05	1.27E-05	Z997-D	2.31E-09	4.99E-09	7.11E-10
AB39	0.	0.	0.	M993M	3.44E-08	1.18E-08	2.83E-09
AB41	0.	0.	0.	M995	9.22E-09	4.56E-09	2.51E-09
Ca-1	1.97E-04	2.13E-05	0.	M997	7.37E-11	1.83E-11	6.88E-11
Sc-46	7.27E-04	4.18E-09	0.	M998	0.	1.06E-05	2.90E-07
C851	0.	3.60E-09	2.00E-09	M999-D	0.	6.03E-06	1.50E-06
M954	0.	8.90E-06	1.17E-06	TC99	3.37E-10	9.26E-10	1.20E-08
FESS	3.78E-06	2.68E-06	6.25E-07	TC101	1.79E-07	2.63E-07	7.17E-08
FES9	5.87E-06	1.37E-05	5.29E-06	TC103	3.60E-10	5.12E-10	5.83E-07
C057	0.	2.38E-07	2.99E-07	PU103-D	2.55E-07	0.	1.89E-07
C058	0.	9.72E-07	2.24E-06	PU105-D	3.92E-06	0.	4.46E-09
C060	0.	2.91E-06	6.33E-06	PU106-D	3.18E-06	0.	4.94E-07
M159	1.32E-05	4.64E-05	2.24E-06	M105	1.73E-07	1.25E-07	8.20E-08
M163	1.77E-04	1.25E-05	6.00E-06	M107	0.	2.08E-07	1.34E-08
M165	7.69E-07	9.57E-08	4.30E-08	M109	0.	2.51E-07	5.70E-08
C064	0.	1.15E-07	5.41E-08	AD110M-D	2.95E-07	1.94E-07	1.16E-07
Zn65	5.78E-06	7.00E-05	9.33E-06	AD111M-D	8.29E-08	3.44E-08	1.73E-08
Zn69	2.40E-07	5.60E-07	5.11E-08	CO113M	0.	4.51E-06	1.55E-07
SE79	1.47E-08	2.80E-08	6.27E-07	CO115M	0.	2.69E-06	8.39E-08
BR87	0.	3.73E-06	6.27E-07	SM123-D	9.44E-05	7.29E-07	1.08E-06
BR87-D	0.	0.	3.04E-06	SM124-D	1.19E-05	2.37E-07	5.37E-07
BR89	0.	0.	5.74E-08	SM125-D	1.16E-04	2.14E-06	3.20E-06
BR89-D	0.	0.	7.27E-09	SM126-D	3.87E-06	7.11E-08	1.51E-06
BR95	0.	0.	3.65E-09	SM127-D	2.48E-06	2.71E-08	5.80E-07
KR95M	0.	0.	0.	SM127M-D	3.63E-07	7.76E-09	1.37E-07
KR95	0.	0.	0.	TE129M-D	9.67E-06	3.43E-06	5.12E-07
KR87	0.	0.	0.	TE127	1.58E-07	5.60E-08	3.49E-08
KC88-D	0.	0.	0.	TE129M-D	1.63E-05	6.05E-06	2.58E-06
KR89	0.	0.	0.	TE131M-D	6.44E-06	1.67E-06	1.09E-08
AB86	0.	2.94E-05	1.40E-05	TE131M-D	2.44E-06	1.17E-06	9.76E-07
AB87	0.	1.75E-05	6.11E-06	TE131-D	2.79E-06	1.15E-06	8.72E-09
AB88	0.	4.52E-06	4.54E-06	TE132-D	3.49E-06	2.21E-06	2.08E-06
AB89-D	0.	5.40E-06	3.89E-06	TE133M-D	6.44E-08	3.64E-08	3.56E-08
SR89-U	4.40E-04	0.	0.	TE133-D	4.47E-08	2.87E-08	3.67E-08
SR90-D	8.30E-03	0.	0.	TE139	4.66E-06	2.92E-06	6.54E-06
SR91-D	8.07E-06	0.	0.	TE139	1.03E-06	2.98E-06	1.19E-06
SR92-D	3.05E-06	0.	0.	TE131-D	5.85E-06	8.19E-06	4.40E-06



TABLE 4 (contd)  
Page 2 of 4

ADULT INGESTION DOSE		COMMITMENT FACTORS (MRM/50Y PER PCI INGESTED IN FIRST YR)					ADULT INGESTION DOSE		COMMITMENT FACTORS (MRM/50Y PER PCI INGESTED IN FIRST YR)						
ISOTOPE	DOSE	LIVER	TOTAL BODY	THYROID	KIDNEY	LUNG	GI-LLI	ISOTOPE	DOSE	LIVER	TOTAL BODY	THYROID	KIDNEY	LUNG	GI-LLI
H3	1.05E-07	1.05E-07	1.05E-07	1.05E-07	1.05E-07	1.05E-07	1.05E-07	Y90	9.62E-09	0.	2.58E-10	0.	0.	0.	1.02E-04
CE10	3.18E-06	4.91E-07	7.96E-08	0.	3.71E-07	0.	2.68E-05	Y91M-D	9.09E-11	0.	3.52E-12	0.	0.	0.	2.67E-10
C14	2.88E-06	5.68E-07	5.68E-07	5.68E-07	5.68E-07	5.68E-07	5.68E-07	Y91	1.41E-07	0.	3.77E-09	0.	0.	0.	7.76E-05
N13	9.38E-09	8.38E-09	8.38E-09	8.38E-09	8.38E-09	8.38E-09	8.38E-09	Y93	9.45E-10	0.	2.47E-11	0.	0.	0.	1.68E-05
F18	8.24E-07	6.92E-08	0.	1.65E-08	0.	0.	0.	Z8933-D	2.68E-09	0.	7.60E-11	0.	0.	0.	8.50E-05
NA22	1.74E-05	1.74E-05	1.74E-05	1.74E-05	1.74E-05	1.74E-05	1.74E-05	Z895-D	4.18E-08	2.34E-09	1.09E-09	0.	8.87E-09	0.	2.43E-06
NA24	1.70E-06	1.70E-06	1.70E-06	1.70E-06	1.70E-06	1.70E-06	1.70E-06	Z897-D	3.06E-08	9.75E-09	6.50E-09	0.	1.53E-08	0.	3.09E-05
P32	1.93E-04	1.20E-05	7.40E-06	0.	0.	0.	0.	M893M	2.55E-08	8.32E-09	2.05E-09	0.	9.57E-09	0.	3.84E-06
AB29	0.	0.	0.	0.	0.	0.	0.	M895	6.22E-09	3.46E-09	1.86E-09	0.	3.42E-09	0.	2.10E-05
AB41	1.83E-05	2.00E-05	0.	0.	0.	0.	0.	M897	5.27E-11	1.37E-11	4.82E-12	0.	1.54E-11	0.	4.87E-08
CA41	5.51E-09	3.11E-09	0.	0.	0.	0.	0.	M899-D	0.	4.31E-06	8.20E-07	0.	2.13E-07	0.	1.22E-06
CS46	0.	2.64E-09	1.59E-09	0.	0.	0.	0.	M900-D	0.	4.31E-06	8.20E-07	0.	2.13E-07	0.	9.99E-06
CS51	0.	4.57E-06	8.72E-07	0.	1.36E-06	0.	1.40E-05	TC99	2.47E-10	6.98E-10	8.09E-09	0.	1.06E-08	0.	4.13E-07
M554	0.	1.15E-07	2.04E-08	0.	1.44E-07	0.	3.67E-06	TC99	1.25E-07	1.86E-07	5.02E-08	0.	2.34E-06	0.	6.08E-06
FESS	2.75E-06	1.90E-06	4.43E-07	0.	0.	0.	0.	TC101	2.54E-10	3.66E-10	3.59E-09	0.	6.59E-09	0.	1.10E-21
FES9	4.36E-05	1.02E-05	3.91E-06	0.	0.	0.	0.	P0103-D	1.85E-07	0.	7.97E-08	0.	7.06E-07	0.	2.16E-05
CO58	0.	1.75E-07	2.91E-07	0.	0.	0.	0.	P0105-D	1.54E-08	0.	6.08E-09	0.	1.99E-07	0.	9.42E-06
CO60	0.	2.14E-06	4.72E-06	0.	0.	0.	0.	P0106-D	2.79E-06	3.48E-07	0.	0.	5.31E-06	0.	1.78E-04
M159	2.76E-05	3.35E-05	1.63E-06	0.	0.	0.	0.	P0107	1.21E-07	8.85E-08	5.83E-08	0.	3.76E-07	0.	1.41E-05
M163	1.20E-04	9.01E-06	4.34E-06	0.	0.	0.	0.	P0109	0.	1.77E-07	3.99E-08	0.	1.32E-06	0.	9.11E-07
CU64	5.28E-07	6.66E-08	3.13E-08	0.	0.	0.	0.	A6110M-D	5.81E-08	2.43E-08	1.21E-08	0.	2.91E-07	0.	1.94E-05
ZNA5	4.84E-06	1.54E-05	6.96E-06	0.	0.	0.	0.	C0113M	0.	3.10E-06	1.02E-07	0.	3.50E-06	0.	4.46E-05
ZNA9	1.70E-07	4.08E-07	3.73E-08	0.	2.47E-07	0.	2.49E-05	C0115M	0.	1.84E-06	5.87E-08	0.	1.46E-06	0.	2.56E-05
SE79	1.03E-08	1.97E-08	1.37E-09	0.	1.28E-08	0.	5.38E-07	SM125-D	3.11E-05	5.15E-07	7.59E-07	4.38E-07	0.	0.	7.74E-05
B822	0.	2.26E-06	4.39E-07	0.	0.	0.	0.	SM126-D	8.33E-06	1.68E-07	3.78E-07	1.39E-07	0.	0.	1.04E-04
B833-C	0.	4.02E-08	0.	0.	0.	0.	0.	SM127	2.88E-06	2.34E-08	2.40E-06	6.92E-07	0.	0.	2.43E-05
B835	0.	5.21E-08	0.	0.	0.	0.	0.	SM128-D	2.88E-06	2.00E-08	4.76E-07	1.82E-09	0.	0.	7.95E-05
B838	0.	2.14E-09	0.	0.	0.	0.	0.	SM129	1.79E-06	2.00E-08	4.76E-07	1.82E-09	0.	0.	1.38E-06
B839	0.	0.	0.	0.	0.	0.	0.	SM130	1.9E-06	2.34E-08	9.90E-08	3.10E-09	0.	0.	5.90E-05
B840	0.	0.	0.	0.	0.	0.	0.	SM131M-D	2.58E-06	9.71E-07	3.59E-07	8.66E-07	1.09E-05	0.	1.07E-05
B841	0.	0.	0.	0.	0.	0.	0.	TE125M	6.77E-06	2.42E-06	8.25E-07	1.73E-06	2.75E-05	0.	2.27E-05
B842	0.	0.	0.	0.	0.	0.	0.	TE127M-D	1.10E-07	3.95E-08	2.38E-08	8.15E-08	4.48E-07	0.	8.68E-06
B843	0.	0.	0.	0.	0.	0.	0.	TE129M-D	1.13E-05	4.29E-06	1.82E-06	3.95E-06	4.80E-05	0.	5.79E-05
B844	0.	2.11E-05	9.83E-06	0.	0.	0.	0.	TE129	3.14E-08	1.80E-08	7.65E-09	2.41E-08	1.32E-07	0.	2.37E-08
B845	0.	1.23E-05	4.28E-06	0.	0.	0.	0.	TE131M-D	1.73E-06	8.66E-07	7.05E-07	1.34E-06	8.57E-06	0.	8.40E-05
B846	0.	6.05E-08	3.21E-08	0.	0.	0.	0.	TE132-D	1.97E-06	8.23E-08	6.22E-08	1.62E-08	8.63E-08	0.	2.79E-09
B847	0.	4.01E-08	2.82E-08	0.	0.	0.	0.	TE133M-D	2.52E-06	1.63E-06	1.53E-06	1.80E-06	1.57E-05	0.	7.71E-09
B848	0.	0.	0.	0.	0.	0.	0.	TE134-D	4.65E-08	2.70E-08	2.60E-08	3.91E-08	2.67E-07	0.	6.64E-08
B849	0.	3.08E-04	8.84E-06	0.	0.	0.	0.	TE134-D	3.24E-06	2.12E-06	1.30E-06	2.63E-06	2.05E-07	0.	3.59E-11
B850	0.	1.84E-03	0.	0.	0.	0.	0.	I129	3.27E-06	2.81E-06	9.27E-06	7.23E-03	6.04E-06	0.	4.44E-07
B851	0.	2.29E-07	0.	0.	0.	0.	0.	I130	7.56E-07	2.23E-06	8.00E-07	1.89E-04	3.48E-06	0.	1.92E-06
B852	0.	2.15E-06	9.30E-08	0.	0.	0.	0.	I131-D	4.14E-06	5.95E-06	3.41E-06	1.95E-03	1.02E-05	0.	1.57E-06





TABLE 5 (contd)  
Page 4 of 4

ISOTOPE	INFANT INHALATION DOSE COMMITMENT FACTORS (MBEM/SOY) PER PCI INHALED IN FIRST YR)					ADULT INHALATION DOSE COMMITMENT FACTORS (MBEM/SOY) PER PCI INHALED IN FIRST YR)				
	ADVE	LIVER	TOTAL BODY	THYROID	KIDNEY	ADVE	LIVER	TOTAL BODY	THYROID	KIDNEY
1132	1.21E-06	2.53E-06	8.99E-07	1.21E-04	2.82E-06	0.	2.02E-02	3.43E-03	0.	6.85E-02
1133-U	9.46E-06	1.37E-05	4.00E-06	2.54E-03	1.60E-05	0.	1.33E-05	1.19E-06	0.	1.23E-04
1136	6.58E-07	1.34E-06	4.75E-07	3.18E-05	1.49E-06	0.	2.96E-03	7.12E-04	0.	1.10E-02
1135-U	2.76E-06	5.43E-06	1.99E-06	4.97E-04	6.05E-06	0.	0.	0.	0.	9.48E-06
1131M	0.	0.	0.	0.	0.	0.	1.56E-03	3.12E-04	0.	4.14E-05
1133M	0.	0.	0.	0.	0.	0.	1.77E-04	3.56E-05	0.	7.30E-06
1133	0.	0.	0.	0.	0.	0.	2.57E-03	5.13E-04	0.	5.31E-05
1135M	0.	0.	0.	0.	0.	0.	2.48E-01	2.05E-01	0.	7.83E-01
1135	0.	0.	0.	0.	0.	0.	1.60E-01	1.60E-01	0.	1.53E-04
1137	0.	0.	0.	0.	0.	0.	3.69E-03	4.72E-03	0.	3.49E-04
1138-U	0.	0.	0.	0.	0.	0.	5.29E-03	2.48E-01	0.	1.86E-01
1138-M	0.	0.	0.	0.	0.	0.	1.62E-03	3.03E-05	0.	1.13E-04
1138-D	0.	0.	0.	0.	0.	0.	4.65E-01	1.10E-02	0.	5.01E-02
1139	2.83E-04	5.02E-04	5.32E-05	0.	0.	0.	1.34E-01	6.62E-01	0.	8.09E-01
1139-U	1.00E-06	8.66E-05	4.73E-06	0.	0.	0.	3.46E+00	9.65E-02	0.	8.82E-01
1139-M	3.45E-05	9.61E-05	3.78E-05	0.	0.	0.	3.86E+00	1.53E-01	0.	7.54E-01
1139-D	3.92E-04	4.37E-04	3.25E-05	0.	0.	0.	1.33E-05	7.17E-07	0.	2.70E-06
1140	3.61E-07	5.88E-07	2.84E-07	0.	0.	0.	9.10E+00	3.62E-01	0.	1.62E+00
1142	1.06E-09	7.03E-13	3.07E-11	0.	0.	0.	6.84E-06	1.19E-06	0.	3.68E-06
1143	4.00E-05	4.00E-08	2.07E-06	0.	0.	0.	2.57E-01	0.	0.	2.09E-02
1144	1.21E-10	7.70E-14	3.55E-12	0.	0.	0.	5.44E-02	0.	0.	1.09E-02
1145	2.84E-11	2.36E-14	1.40E-12	0.	0.	0.	3.83E-03	0.	0.	3.56E-01
1146	4.85E-09	1.40E-09	2.45E-10	0.	0.	0.	3.75E-03	0.	0.	1.07E-02
1147	7.36E-10	2.89E-10	6.46E-11	0.	0.	0.	5.01E-02	0.	0.	1.01E-02
1148	1.99E-05	1.19E-05	1.42E-06	0.	0.	0.	3.60E-03	0.	0.	3.35E-01
1149	2.99E-07	1.38E-07	1.58E-08	0.	0.	0.	6.65E-03	0.	0.	9.13E-05
1150	2.29E-03	8.95E-04	1.26E-04	0.	0.	0.	3.25E-07	0.	0.	6.08E-07
1151	1.02E-05	3.74E-06	4.99E-07	0.	0.	0.	3.03E+00	2.32E-01	0.	7.49E-01
1152	3.42E-11	1.32E-11	1.72E-12	0.	0.	0.	3.03E+00	2.32E-01	0.	3.49E-01
1153	5.67E-06	5.81E-06	3.57E-07	0.	0.	0.	3.03E+00	2.32E-01	0.	3.49E-01
1154	3.91E-04	3.07E-05	1.56E-05	0.	0.	0.	3.03E+00	2.32E-01	0.	3.49E-01
1155	5.00E-05	1.74E-05	9.94E-06	0.	0.	0.	3.03E+00	2.32E-01	0.	3.49E-01
1156	3.34E-06	4.82E-07	2.66E-07	0.	0.	0.	3.03E+00	2.32E-01	0.	3.49E-01
1157	3.10E-07	4.08E-08	1.78E-08	0.	0.	0.	3.03E+00	2.32E-01	0.	3.49E-01
1158	7.52E-08	1.01E-08	5.55E-09	0.	0.	0.	3.03E+00	2.32E-01	0.	3.49E-01
1159	3.36E-04	6.52E-05	1.63E-05	0.	0.	0.	3.03E+00	2.32E-01	0.	3.49E-01
1160	1.53E-07	1.89E-07	9.06E-09	0.	0.	0.	3.03E+00	2.32E-01	0.	3.49E-01
1161	7.83E-04	1.77E-04	1.72E-04	0.	0.	0.	3.03E+00	2.32E-01	0.	3.49E-01
1162	5.72E-03	3.66E-03	3.46E-03	0.	0.	0.	3.03E+00	2.32E-01	0.	3.49E-01
1163	5.72E-05	9.59E-06	1.40E-06	0.	0.	0.	3.03E+00	2.32E-01	0.	3.49E-01
1164	1.12E-06	1.42E-06	1.40E-06	0.	0.	0.	3.03E+00	2.32E-01	0.	3.49E-01
1165	1.65E-03	3.07E-04	2.51E-04	0.	0.	0.	3.03E+00	2.32E-01	0.	3.49E-01
1166	4.86E-08	1.46E-08	1.01E-09	0.	0.	0.	3.03E+00	2.32E-01	0.	3.49E-01
1167	1.57E-06	4.83E-07	5.58E-07	0.	0.	0.	3.03E+00	2.32E-01	0.	3.49E-01
1168	9.26E-09	6.44E-09	2.23E-09	0.	0.	0.	3.03E+00	2.32E-01	0.	3.49E-01

TABLE 6 (cont'd)  
Page 2 of 4

TABLE 6  
Page 1 of 4

ISOTOPE	CHILD INHALATION DOSE COMMITMENT FACTORS(INFREM)/50Y PER PCI INHALED IN FIRST YR	ADULT INHALATION DOSE COMMITMENT FACTORS(INFREM)/50Y PER PCI INHALED IN FIRST YR	ISOTOPE	(MILD) INHALATION DOSE COMMITMENT FACTORS(INFREM)/50Y PER PCI INHALED IN FIRST YR	ISOTOPE	ADULT INHALATION DOSE COMMITMENT FACTORS(INFREM)/50Y PER PCI INHALED IN FIRST YR
	NOSE	LIVER	TOTAL BODY	KIDNEY	LUNG	GI-LLI
MB3	3.04E-07	3.04E-07	3.04E-07	3.04E-07	3.04E-07	3.04E-07
BI10	9.41E-04	9.41E-04	7.12E-05	7.12E-05	7.12E-05	7.12E-05
C14	9.70E-06	1.82E-06	1.82E-06	1.82E-06	1.82E-06	1.82E-06
NI3	2.33E-08	2.33E-08	2.33E-08	2.33E-08	2.33E-08	2.33E-08
FI18	1.88E-06	1.88E-06	3.37E-07	3.37E-07	3.37E-07	3.37E-07
MA22	4.41E-05	4.41E-05	4.41E-05	4.41E-05	4.41E-05	4.41E-05
MA24	4.35E-06	4.35E-06	4.35E-06	4.35E-06	4.35E-06	4.35E-06
P32	7.04E-04	3.09E-05	2.67E-05	2.67E-05	2.67E-05	2.67E-05
AP39	0	0	0	0	0	0
AP41	7.04E-05	0	7.04E-06	7.04E-06	7.04E-06	7.04E-06
CS46	1.97E-04	2.79E-04	1.04E-04	1.04E-04	1.04E-04	1.04E-04
CS51	0	0	4.19E-08	4.19E-08	4.19E-08	4.19E-08
MS54	1.18E-05	2.53E-06	2.53E-06	2.53E-06	2.53E-06	2.53E-06
MS56	4.48E-06	4.48E-06	4.48E-06	4.48E-06	4.48E-06	4.48E-06
FE55	1.28E-05	9.04E-06	5.11E-06	5.11E-06	5.11E-06	5.11E-06
FE59	5.51E-06	2.44E-07	2.44E-07	2.44E-07	2.44E-07	2.44E-07
CO57	6.79E-07	8.52E-07	8.52E-07	8.52E-07	8.52E-07	8.52E-07
CO58	0	0	0	0	0	0
CO60	1.66E-05	4.67E-06	4.67E-06	4.67E-06	4.67E-06	4.67E-06
NI59	2.22E-04	1.25E-05	7.50E-11	7.50E-11	7.50E-11	7.50E-11
NI63	9.01E-10	7.99E-11	4.44E-11	4.44E-11	4.44E-11	4.44E-11
CU64	1.15E-05	3.04E-05	1.90E-10	1.90E-10	1.90E-10	1.90E-10
Zn65	4.24E-09	7.28E-09	8.59E-10	8.59E-10	8.59E-10	8.59E-10
Zn69	1.81E-11	2.61E-11	2.61E-11	2.61E-11	2.61E-11	2.61E-11
SE79	0	0	0	0	0	0
MB82	0	0	0	0	0	0
MB83-D	0	0	0	0	0	0
MB84	0	0	0	0	0	0
KB85	0	0	0	0	0	0
MB88	0	0	0	0	0	0
MB89	0	0	0	0	0	0
MB93-D	0	0	0	0	0	0
KB95	0	0	0	0	0	0
KB97	0	0	0	0	0	0
MB98-D	0	0	0	0	0	0
KB99	0	0	0	0	0	0
MB96	0	5.34E-05	3.09E-05	3.09E-05	3.09E-05	3.09E-05
MB97	0	3.18E-05	1.37E-05	1.37E-05	1.37E-05	1.37E-05
MB98	0	1.52E-07	9.90E-08	9.90E-08	9.90E-08	9.90E-08
MB99-D	0	4.33E-08	7.83E-08	7.83E-08	7.83E-08	7.83E-08
SB99-D	1.62E-04	4.66E-06	4.66E-06	4.66E-06	4.66E-06	4.66E-06
SB99-D	2.73E-02	1.74E-03	1.74E-03	1.74E-03	1.74E-03	1.74E-03
SB99-D	3.29E-08	0	0	0	0	0
SB99-D	3.54E-09	0	0	0	0	0
	1.42E-10	0	0	0	0	0
	6.44E-06	6.55E-05	6.55E-05	6.55E-05	6.55E-05	6.55E-05

\*Includes a 50% increase to account for percutaneous transpiration.



TABLE 6 (cont'd)  
Page 4 of 4

TABLE 6 (cont'd)  
Page 3 of 4

CHILD INHALATION DOSE COMMITMENT FACTORS (MREM/SV) PER PCI INHALED IN FIRST YR		CHILD INHALATION DOSE COMMITMENT FACTORS (MREM/SV) PER PCI INHALED IN FIRST YR					
ISOTOPE	BONE	LIVER	TOTAL BODY	ISOTOPE	BONE	LIVER	TOTAL BODY
I132	5.72E-07	1.10E-06	5.07E-07	5.23E-05	1.09E-06	0.	0.
I133-U	4.48E-06	5.49E-06	2.08E-06	1.84E-03	9.13E-06	0.	0.
I133a	3.17E-07	5.84E-07	2.69E-07	1.37E-05	8.92E-07	0.	2.58E-07
I135-U	1.33E-06	2.36E-06	1.12E-06	2.14E-04	3.62E-06	0.	1.20E-06
RE133m	0.	0.	0.	0.	0.	3.30E-09	0.
RE133a	0.	0.	0.	0.	0.	4.36E-09	0.
RE133b	0.	0.	0.	0.	0.	3.66E-09	0.
RE133M	0.	0.	0.	0.	0.	4.48E-09	0.
RE135	0.	0.	0.	0.	0.	9.09E-09	0.
RE137	0.	0.	0.	0.	0.	4.07E-08	0.
RE138-U	0.	0.	0.	0.	0.	5.17E-08	0.
CS136m-U	6.33E-08	8.92E-08	6.12E-08	0.	0.	0.	7.92E-08
CS136	1.76E-04	2.74E-04	6.07E-04	0.	0.	0.	0.
CS135	6.23E-05	4.13E-05	6.45E-06	0.	0.	0.	0.
CS136	1.76E-05	4.62E-05	3.16E-05	0.	0.	0.	0.
CS137-U	2.45E-04	2.23E-04	3.47E-04	0.	0.	0.	0.
CS138	1.09E-07	1.15E-07	5.80E-08	0.	0.	0.	0.
CS139-U	4.98E-10	2.66E-13	1.17E-06	0.	0.	0.	0.
RE140-U	2.00E-05	1.75E-04	1.72E-04	0.	0.	0.	0.
RE141-U	1.35E-11	9.73E-15	7.54E-13	0.	0.	0.	0.
RE142-U	1.74E-09	6.08E-08	2.04E-08	0.	0.	0.	0.
RE143	3.50E-10	1.11E-10	3.49E-11	0.	0.	0.	0.
RE144	1.83E-03	5.72E-06	9.77E-05	0.	0.	0.	0.
RE145	4.99E-06	1.50E-06	2.47E-07	0.	0.	0.	0.
RE146-U	1.61E-11	4.99E-12	6.10E-13	0.	0.	0.	0.
RE147-U	2.92E-04	2.36E-06	1.84E-07	0.	0.	0.	0.
RE148-U	3.31E-05	6.55E-06	1.34E-06	0.	0.	0.	0.
RE149	1.47E-07	1.56E-07	6.25E-07	0.	0.	0.	0.
RE151	3.57E-08	4.33E-09	2.82E-09	0.	0.	0.	0.
RE153	7.24E-08	4.51E-08	4.35E-09	0.	0.	0.	0.
RE152	7.42E-04	1.37E-04	1.61E-04	0.	0.	0.	0.
RE154	7.74E-03	2.99E-04	3.18E-05	0.	0.	0.	0.
RE155	5.80E-04	8.05E-05	2.18E-05	0.	0.	0.	0.
RE156	7.89E-06	4.23E-06	8.75E-07	0.	0.	0.	0.
RE160	1.34E-03	2.81E-04	9.37E-06	0.	0.	0.	0.
RE161	2.66E-08	6.52E-09	8.99E-10	0.	0.	0.	0.
RE165	8.31E-07	2.08E-07	2.91E-08	0.	0.	0.	0.
RE167	4.61E-09	2.61E-09	1.17E-09	0.	0.	0.	0.

TABLE 7  
Page 3 of 4

TABLE 7 (cont'd)  
Page 2 of 4

TEEN INHALATION DOSE COMMITMENT FACTORS (MREM/SOY PER PCI INHALED IN FIRST YR)		TEEN INHALATION DOSE COMMITMENT FACTORS (MREM/SOY PER PCI INHALED IN FIRST YR)		TEEN INHALATION DOSE COMMITMENT FACTORS (MREM/SOY PER PCI INHALED IN FIRST YR)		TEEN INHALATION DOSE COMMITMENT FACTORS (MREM/SOY PER PCI INHALED IN FIRST YR)	
ISOTOPE	BONE	LIVER	TOTAL BODY	THYROID	KIDNEY	LUNG	GI-LLI
M3*	3.73E-07	0.	1.06E-08	0.	0.	3.66E-05	6.99E-05
4410	2.34E-04	6.33E-05	7.09E-07	1.59E-07	1.59E-07	1.59E-07	1.77E-05
C14	2.25E-05	6.09E-07	6.09E-07	6.09E-07	6.09E-07	6.09E-07	6.09E-07
N13	6.85E-09	6.85E-09	6.85E-09	6.85E-09	6.85E-09	6.85E-09	6.85E-09
F19	6.52E-07	7.10E-07	7.10E-07	7.10E-07	7.10E-07	7.10E-07	7.10E-07
8224	1.76E-05	1.76E-05	1.76E-05	1.76E-05	1.76E-05	1.76E-05	1.76E-05
8424	1.72E-05	1.72E-05	1.72E-05	1.72E-05	1.72E-05	1.72E-05	1.72E-05
P32	2.36E-04	1.37E-05	8.95E-06	0.	0.	0.	0.
8339	0.	0.	0.	0.	0.	0.	0.
8041	6.05E-05	4.36E-06	4.36E-06	4.36E-06	4.36E-06	4.36E-06	4.36E-06
C44	7.24E-05	1.41E-04	1.41E-04	1.41E-04	1.41E-04	1.41E-04	1.41E-04
SC44	0.	1.61E-05	1.61E-05	1.61E-05	1.61E-05	1.61E-05	1.61E-05
CS51	0.	6.39E-06	6.39E-06	6.39E-06	6.39E-06	6.39E-06	6.39E-06
MS54	0.	2.12E-10	3.15E-11	0.	0.	0.	0.
MS56	0.	2.08E-06	6.93E-07	0.	0.	0.	0.
FE59	1.99E-06	4.62E-06	1.79E-06	0.	0.	0.	0.
CO57	0.	1.18E-07	1.15E-07	0.	0.	0.	0.
CO58	0.	1.89E-06	2.44E-06	0.	0.	0.	0.
CO60	0.	1.82E-06	9.26E-07	0.	0.	0.	0.
N159	5.44E-06	2.02E-06	2.47E-06	0.	0.	0.	0.
N163	7.29E-05	5.43E-06	2.47E-06	0.	0.	0.	0.
N165	2.73E-10	3.64E-11	1.50E-11	0.	0.	0.	0.
CU64	0.	7.54E-10	1.04E-10	0.	0.	0.	0.
Zn65	6.82E-06	1.67E-05	7.80E-06	0.	0.	0.	0.
Zn69	1.44E-09	3.39E-09	3.11E-10	0.	0.	0.	0.
Zn69+D	6.04E-12	1.15E-11	6.07E-13	0.	0.	0.	0.
SE79	0.	5.43E-07	6.71E-08	0.	0.	0.	0.
SR82	0.	0.	2.28E-06	0.	0.	0.	0.
SR83-D	0.	0.	4.30E-08	0.	0.	0.	0.
SR84	0.	0.	5.41E-08	0.	0.	0.	0.
SR85	0.	0.	2.29E-09	0.	0.	0.	0.
SR85+D	0.	0.	0.	0.	0.	0.	0.
SR86	0.	0.	0.	0.	0.	0.	0.
SR87	0.	0.	0.	0.	0.	0.	0.
SR88	0.	0.	0.	0.	0.	0.	0.
SR89-D	0.	0.	0.	0.	0.	0.	0.
SR89	0.	0.	0.	0.	0.	0.	0.
SR90-D	0.	0.	0.	0.	0.	0.	0.
SR91-D	0.	0.	0.	0.	0.	0.	0.
SR92+D	0.	0.	0.	0.	0.	0.	0.

\* Includes a 50% increase to account for percutaneous transpiration.



TABLE B (cont'd)  
Page 2 of 4

ISOTOPE	ADULT INHALATION DOSE COMMITMENT FACTORS (mrem/50y) PER PCI INHALED IN FIRST YR				ADULT INHALATION DOSE COMMITMENT FACTORS (mrem/50y) PER PCI INHALED IN FIRST YR			
	BONE	LIVER	TOTAL BODY	THYROID	BONE	LIVER	TOTAL BODY	THYROID
BE10	1.08E-04	3.06E-05	1.58E-07	1.58E-07	1.58E-07	1.58E-07	1.58E-07	1.58E-07
BE11	2.27E-06	4.29E-07	4.26E-07	4.26E-07	4.26E-07	4.26E-07	4.26E-07	4.26E-07
BE13	6.27E-09	6.27E-09	6.27E-09	6.27E-09	6.27E-09	6.27E-09	6.27E-09	6.27E-09
BE18	4.71E-07	5.19E-08	0	0	0	0	0	0
MA22	1.31E-05	1.30E-05	1.30E-05	1.30E-05	1.30E-05	1.30E-05	1.30E-05	1.30E-05
MA24	1.28E-06	1.28E-06	1.28E-06	1.28E-06	1.28E-06	1.28E-06	1.28E-06	1.28E-06
PS22	1.65E-04	0.64E-04	0	0	0	0	0	0
KA39	0	0	0	0	0	0	0	0
CA41	3.83E-05	4.13E-06	0	0	0	0	0	0
SC44	5.51E-05	3.11E-05	0	0	0	0	0	0
CS51	0	1.25E-08	7.44E-09	0	0	0	0	0
MO54	0	4.94E-06	7.87E-07	0	0	0	0	0
MO56	3.07E-06	1.55E-10	2.29E-11	0	0	0	0	0
FE59	1.47E-06	4.47E-06	1.32E-06	0	0	0	0	0
CO57	0	6.45E-04	0.39E-04	0	0	0	0	0
CO58	0	1.94E-07	2.59E-07	0	0	0	0	0
CO60	0	1.44E-06	1.85E-06	0	0	0	0	0
NI59	4.04E-04	1.44E-06	6.77E-07	0	0	0	0	0
NI63	5.40E-05	3.93E-06	1.81E-06	0	0	0	0	0
NI65	1.92E-10	2.62E-11	1.14E-11	0	0	0	0	0
CU64	0	1.83E-10	7.69E-11	0	0	0	0	0
Zn65	4.04E-06	1.29E-05	5.62E-06	0	0	0	0	0
Zn69	1.07E-09	2.45E-09	2.24E-10	0	0	0	0	0
SE79	4.24E-12	3.83E-07	6.09E-08	0	0	0	0	0
BR82	0	0	0	0	0	0	0	0
BR83-D	0	0	0	0	0	0	0	0
BR84	0	0	0	0	0	0	0	0
BR85	0	0	0	0	0	0	0	0
BR83M	0	0	0	0	0	0	0	0
BR85M	0	0	0	0	0	0	0	0
BR87	0	0	0	0	0	0	0	0
BR88-D	0	0	0	0	0	0	0	0
BR89	0	0	0	0	0	0	0	0
BR86	0	0	0	0	0	0	0	0
BR87	0	0	0	0	0	0	0	0
BR88	0	0	0	0	0	0	0	0
BR89-D	0	0	0	0	0	0	0	0
BR90-D	0	0	0	0	0	0	0	0
BR91-D	0	0	0	0	0	0	0	0
BR92-D	0	0	0	0	0	0	0	0

\* includes a 50% increase to account for percutaneous transpiration.

