

THE UNIVERSITY OF WISCONSIN—MILWAUKEE

CENTER
FOR
GREAT LAKES STUDIES

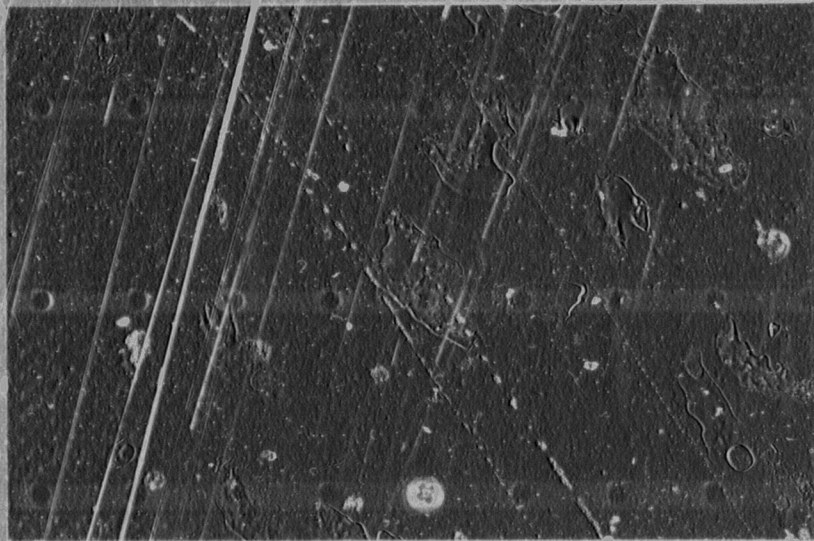

MILWAUKEE, WISCONSIN 53201 U.S.A.

M. SLATER
6/25

SPECIAL REPORT NO. 35
The Effects of Intermittent
Chlorination on Ten Species
of Warmwater Fish

by

A. S. BROOKS and G. L. SEEGERT

Center for Great Lakes Studies
The University of Wisconsin-Milwaukee
Milwaukee, Wisconsin 53201

January, 1978

Revised March, 1978

7811200092.

TABLE OF CONTENTS

Summary and Conclusions i

Acknowledgement ii

Introduction 1

Methods 2

Results 7

Discussion 34

Literature Cited 43

SUMMARY AND CONCLUSIONS

Ten warmwater fish species were tested at 10, 20, and 30C to determine their resistance to monochloramine. The exposure regime consisted of four forty-minute exposures administered at five hour intervals over a 24-hr period. All species exhibited an inverse relationship between temperature and LC50 values. LC50 values generally decreased by a factor of two as the exposure temperature increased from 10 to 30C. LC50 values ranged from 0.35 mg/l at 30C for the emerald shiner to 3.00 mg/l at 10C for the bluegill.

Based on their overall resistance to monochloramine the fish were separated into "sensitive" and "resistant" species. The sensitive group which included (in decreasing order of sensitivity) the emerald shiner, spotfin shiner, common shiner, channel catfish, white sucker, and sauger had 30C LC50 values ranging from 0.35 to 0.71 mg/l. "Resistant" species, freshwater drum, white bass, bluegill, and carp, had LC50 values of 1.15 - 1.50 mg/l at 30C.

The time to mortality was species and temperature dependent. Generally sensitive species died earlier during the exposure regime than did resistant species. Fish also died more rapidly at higher test temperatures. Fish rarely recovered following their initial loss of equilibrium.

The concentrations which produced no mortality were used to calculate safe levels for each species. Based on these calculations to protect the most sensitive species average monochloramine exposures should not exceed 0.2 mg/l for a period not to exceed 160 minutes/day.

ACKNOWLEDGEMENTS

This report represents a final report to Allegheny Power Service Corp., Central Illinois Public Service Co., Cincinnati Gas & Electric Co., Columbus & Southern Ohio Electric Co., Commonwealth Edison Co., Dayton Power & Light Co., Indianapolis Power & Light Co., Ohio Edison Company, Ohio Valley Electric Corp., Public Service Indiana, and Toledo Edison Company who have sponsored this research through a grant to The University of Wisconsin-Milwaukee. We gratefully acknowledge both the financial and technical support provided by the sponsors and their personnel. We especially thank Mr. Wayne Swallow for his efforts in organizing and coordinating the research program with the participating utilities.

We thank Sherman Stairs of the Lake Mills Wisconsin Federal Hatchery for providing the carp and John Hawkinson of the Seneca-ville Ohio Federal Hatchery for providing the sauger used in these studies. Lee Eberly and his staff at The Praire Island Nuclear Plant of Northern States Power Company provided valuable assistance during the drum collections on the Mississippi River. Carl Baker and his staff at the Sandusky office of the Ohio Department of Natural Resources provided similar assistance with the white bass and drum collections in Lake Erie.

John VandeCastle, Ken Gradall, Nancy Liptak, Glen Magyera, Pat Thomas, Jim Jabes, Margaret Thielke and Nathania Wallace assisted on the fish bioassays and collections.

Joan Flores did the typing and Ratko Ristic assisted with the figure preparation.

INTRODUCTION

Chlorine is used in numerous industrial and water treatment processes as a biocide for fouling organisms. In the electric power generating industry chlorine is periodically applied to the cooling water to prevent the buildup of bacterial slimes which impair heat transfer across the condenser tubes. The environmental impact of chlorinated effluents from power plants is of concern because of the effect on non-target organisms such as fish and invertebrates (Brungs 1973, 1976; Brooks and Seegert 1977 a and b).

Chlorine normally exists either as free chlorine, hypochlorous acid (HOCl) and hypochlorite ion (OCl^-), or as monochloramine (NH_2Cl) in the presence of ammonia (NH_3). In water bodies of high quality, where the ammonia levels are low, free chlorine is the principal chlorine species present in chlorinated effluents, while monochloramine predominates in waterways which contain high levels of ammonia.

Previous studies have reported on the toxicity of free chlorine to several species of Great Lakes fishes (Brooks and Seegert 1977 a and b). The present study was undertaken to determine the effects of multiple exposures of monochloramine to ten species of fish representative of midwestern river systems. The species studied were the emerald shiner (*Notropis atherinoides*), common shiner (*N. cornutus*), spotfin shiner (*N. spilopterus*), bluegill (*Lepomis macrochirus*), carp (*Cyprinus carpio*), white sucker (*Catostomus commersoni*), channel catfish (*Ictalurus punctatus*), white bass (*Morone chrysops*), sauger (*Stizostedion canadense*) and freshwater drum (*Aplodinotus grunniens*).

METHODS

The fish used in the study were all obtained from sources in the north central region. Emerald shiners were seined from the Wisconsin and Mississippi Rivers near Spring Green and LaCrosse, Wisconsin, respectively. Spotfin shiners were seined from the Wisconsin River near Spring Green, Wisconsin. Common shiners were seined from the Milwaukee River, near Milwaukee, Wisconsin. Bluegills were purchased from the Taal Lake Hatchery near New London, Wisconsin. Carp were donated from hatchery stocks at the Lake Mills Federal Hatchery, Lake Mills, Wisconsin. Catfish were purchased from a hatchery near St. Louis, Missouri. Sauger were donated from hatchery stocks at the Senecaville Federal Hatchery, Senecaville, Ohio. White suckers were purchased from a Milwaukee bait dealer who obtained them from a northern Wisconsin hatchery. Drum were collected by seine and trawl hauls in the Mississippi River near Red Wing, Minnesota. White bass were collected by seining in the Mississippi River near LaCrosse, Wisconsin and from Sandusky Bay in Lake Erie.

All species were acclimated for a minimum of two weeks in large (600-4000ℓ) circular fiberglass holding tanks. Temperature in these tanks was maintained within 1.5C of the desired test temperature. Laboratory lighting was controlled to maintain the normal day-night seasonal regime. Holding tanks were supplied with Lake Michigan water obtained from the Milwaukee municipal system and dechlorinated by activated carbon and sodium sulfite (Na_2SO_3) (Seegert and Brooks 1978 a). Except for the day before and during a bioassay all species received a daily food ration. The sauger

were fed minnow fry. The white bass and drum were fed a combination of ground fish flesh and pelleted trout chow. All other species received only the trout chow.

The bioassays were conducted in 100-liter rectangular glass aquaria covered on the sides with opaque plastic. All species were tested at 10, 20 and 30C. Temperature control (± 1 C) in the bioassay tanks was achieved by connecting the tanks in a flow-through circuit with a 2500 liter thermo-regulated reservoir tank. Water was continuously pumped from the reservoir to the bioassay tanks and returned to the reservoir tank through overflow siphons (Fig. 1).

Five experimental and one control group of 10 fish each were used in each bioassay experiment. Control mortalities during the study were negligible (<1%). The fish were placed in the bioassay tanks the day before the test. Ammonium chloride (1-3 mg/l as N) was added to the reservoir tank at this time to ensure that the total residual chlorine (TRC) would be predominately (>90%) monochloramine during the bioassay test. On the day of the bioassay aqueous sodium hypochlorite (NaOCl) was added to the bioassay tanks with a peristaltic pump over a five minute period to achieve the desired TRC concentration. Air stones in the tanks insured complete mixing. Prior to addition of the hypochlorite, water flow to the tank being chlorinated was shut off and the overflow siphon removed to isolate it from the recirculating system.

One minute following the 5-minute injection period ($t = 6$ min) four water samples were taken for chlorine analysis. Two samples were analyzed amperometrically (American Public Health Assoc. et al. 1976; Seegert et al. 1977) for TRC and two samples

Figure 1. Schematic diagram of the bioassay system.

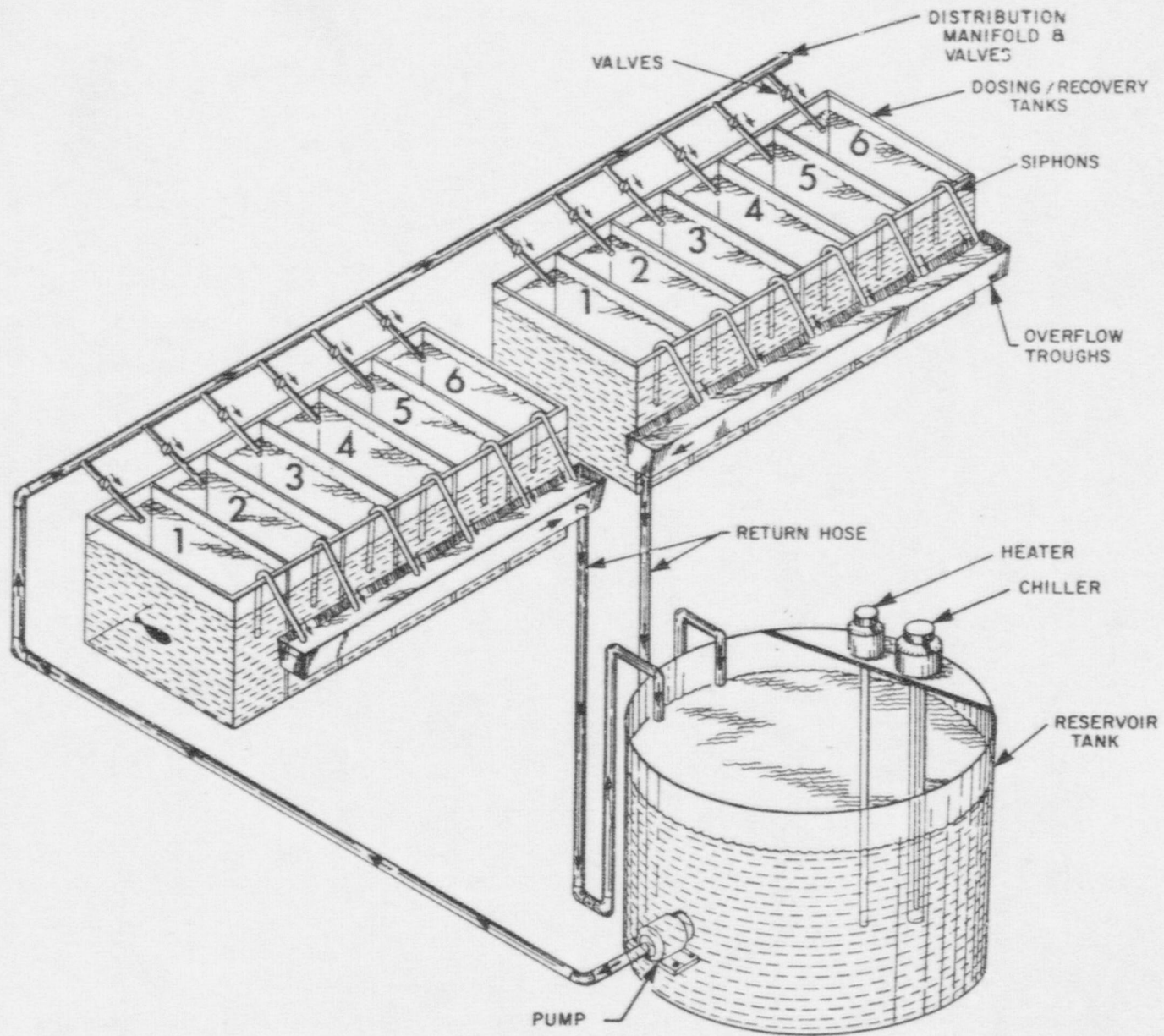

THE UNIVERSITY OF WISCONSIN-MILWAUKEE
CENTER FOR GREAT LAKES STUDIES

Drawn by: *RATKO J. RISTIC* Date: 2 March 1976

were analyzed for free chlorine, monochloramine, dichloramine and TRC using the DPD titrimetric method (APHA et al 1976). Twenty-nine minutes after the 5-minute injection period ended ($t = 34$ min) four more samples were taken for chlorine analysis in the manner described above. Thirty minutes after the initial 5-minute injection period ($t = 35$ min) a solution of sodium sulfite (Na_2SO_3) equimolar to the TRC added was injected over a 5-minute period to reduce the chlorine residual to zero. At the end of the 5-minute sulfite injection period ($t = 40$ min) a sample of water from the bioassay tank was analyzed amperometrically to ensure that all the chlorine had been chemically reduced. Thus, each group of fish experienced a 40-minute TRC exposure consisting of a 5-minute chlorine injection period, a 30-minute period at a relatively constant chlorine concentration, and a 5-minute period during which Na_2SO_3 was injected (Fig. 2). Continuous flow chlorine measurements indicated that the "square wave" depicted in Fig. 2 was an accurate indication of the chlorine concentration in the bioassay tank during the exposure period. After the 40-minute exposure period each bioassay tank was reconnected to the recirculating water system. The initial ($t = 6$ min) and final ($t = 34$ min) TRC values determined amperometrically were averaged to give the average TRC concentration to which the fish were exposed. The values derived from the DPD analysis were averaged to determine the percent monochloramine in the bioassay tanks. The 40-minute exposures described above were repeated three more times at 5 hour intervals to complete the multiple exposure tests. During each 40-minute period the temperature, pH, and dissolved oxygen levels were determined and behavioral observations

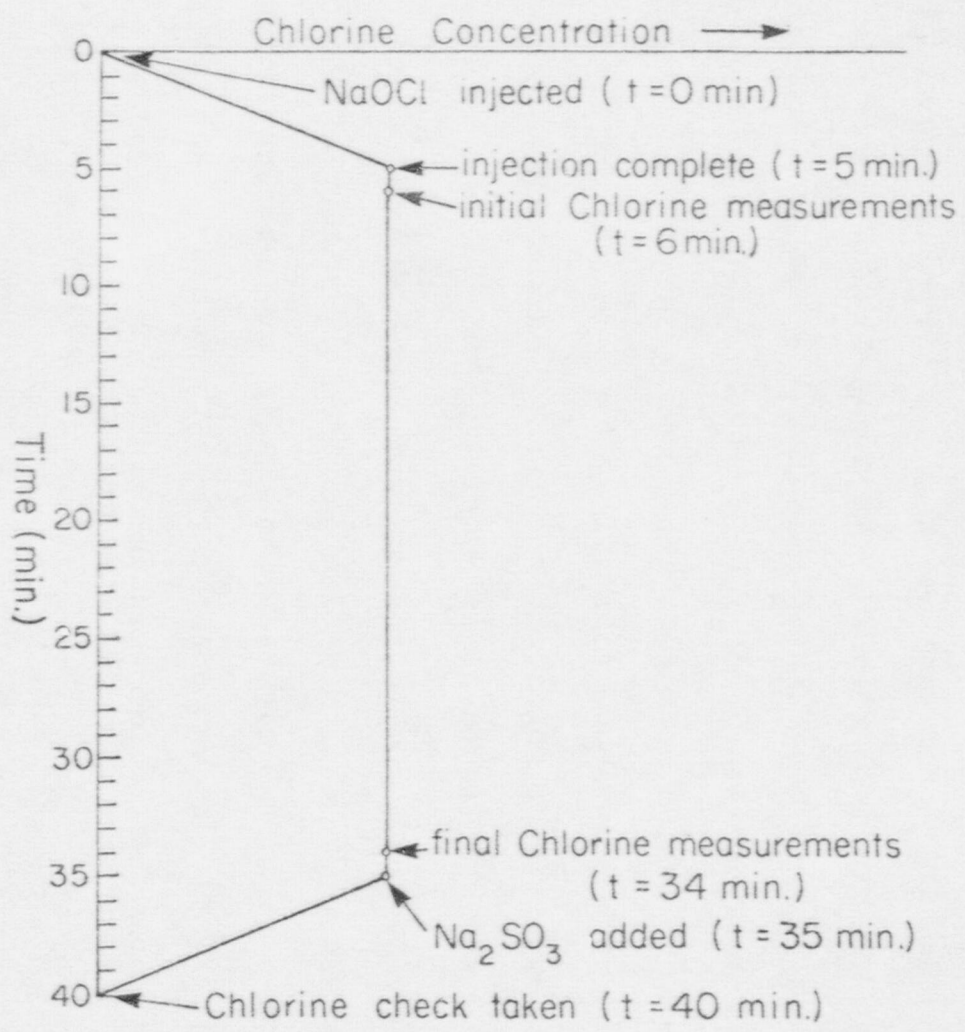

Figure 2. Example of the typical chlorine concentration curve observed during the 40-minute exposure period.

Table 1. Summary of parameters observed during quadruple 40-minute exposures of emerald shiner to residual chlorine.

Test Temperature	10C	20C	30C
Total length (mm) average (range)	67 (48-80)	69 (55-80)	63 (52-80)
Average weight (g)	1.73	1.92	1.55
Number of fish tested	239	177	220
pH (range)	(8.03-8.30)	(8.08-8.35)	(7.96-8.36)
Temperature (C) average (range)	10.2 (9.3-11.3)	19.9 (18.8-20.5)	29.7 (28.4-31.4)
D.O. (mg/liter) average (range)	10.1 (8.9-11.1)	9.0 (8.1-10.2)	7.4 (6.0-7.9)
Monochloramine (%) average (range)	98 (79-100)	97 (86-100)	96 (66-100)
No mortality (mg/liter)	0.46	0.40	0.21
100% mortality (mg/liter)	0.97	a	0.59
Safe factor	0.73	0.78	0.60
LC50 (mg/liter as TRC) (95% confidence interval)	0.63 (0.58-0.68)	0.51 (0.49-0.54)	0.35 ^b (0.33-0.37)
Slope function (95% confidence interval)	1.19 (1.16-1.22)	1.17 (1.07-1.28)	1.25 (1.19-1.30)

^aNone of the concentrations tested consistently caused 100% mortality.

^bDPD measurements used to calculate LC50.

of the fourth exposure and only 5% occurred more than 24 hours after the fourth exposure. Mortalities occurred more rapidly at the warmer temperatures. At 20 and 30C 83% of the mortalities occurred before the fourth exposure while at 10C only 38% occurred before the fourth exposure (Table 2). Mortalities were especially rapid at 20C where 55% of the mortalities occurred after only one exposure (Table 2).

Common Shiners

The common shiner was the most resistant of the shiners. LC 50 values were 0.78, 0.59, and 0.45 mg/l at 10, 20 and 30C, respectively (Fig. 4 and Table 3). Common shiners did not recover after equilibrium loss. Pooled data from the three temperatures indicated that about half the mortalities occurred prior to the fourth exposure, with the other half occurring 24 hours after the fourth exposure. Only 4% of the mortalities occurred more than 24 hours after the fourth exposure. Mortalities were generally more rapid at warmer temperatures. The percentages of mortalities occurring before the fourth exposure were 37, 45, and 58% at 10, 20 and 30C, respectively (Table 2).

Spotfin Shiners

Spotfin shiners were intermediate to emerald and common shiners in their sensitivity to monochloramine. LC50 values were 0.65, 0.59, and 0.41 mg/l at 10, 20 and 30C, respectively (Fig. 5 and Table 4). Spotfin shiners did not recover after equilibrium loss. Mortalities in spotfin shiners followed a pattern very similar to that shown by emerald shiners. Pooled data from the three temperatures indicated that 68% of the spotfin mortalities occurred prior to the fourth exposure, 21% occurred within 24 hours of the

Table 2. Cumulative percent mortality after exposure to monochloramine at all concentrations tested and total number of mortalities observed.

Group		Cumulative Per Cent Mortality ^a				Total number of mortalities 48 hrs after 4th exposure (=100%)
		after 1 exposure	after 2 exposures	after 3 exposures	24 hrs after 4th exposure	
Emerald Shiner	10C	0	13	38	84	82
	20C	55	76	83	100	58
	30C	17	46	83	100	99
Spotfin Sniner	10C	22	36	48	75	108
	20C	81	87	94	100	112
	30C	35	50	58	91	78
Common Shiner	10C	15	16	37	88	67
	20C	10	22	45	97	77
	30C	1	27	58	100	109
Carp	10C	0	14	38	94	119
	20C	0	22	36	93	84
	30C	4	47	75	96	57
Bluegill	10C	0	4	20	67	102
	20C	2	2	22	83	98
	30C	5	18	32	90	62
White Bass	10C	14	35	56	84	43
	20C	11	30	68	100	102
	30C	65	83	87	98	57
Sauger	10C	22	32	44	88	58
	20C	30	95	96	100	81
	30C	55	89	94	100	64
Channel Catfish	10C	0	12	37	93	85
	20C	1	11	30	94	79
	30C	53	58	73	97	60
White Sucker	10C	25	55	68	89	56
	20C	34	43	54	95	76
	27C	67	79	86	99	69
Drum	10C	0	2	13	51	86
	20C	0	24	70	100	41

^a Percentage mortality was calculated from the number of mortalities at the specified time compared to the total number of mortalities suffered by that group after 48 hours.

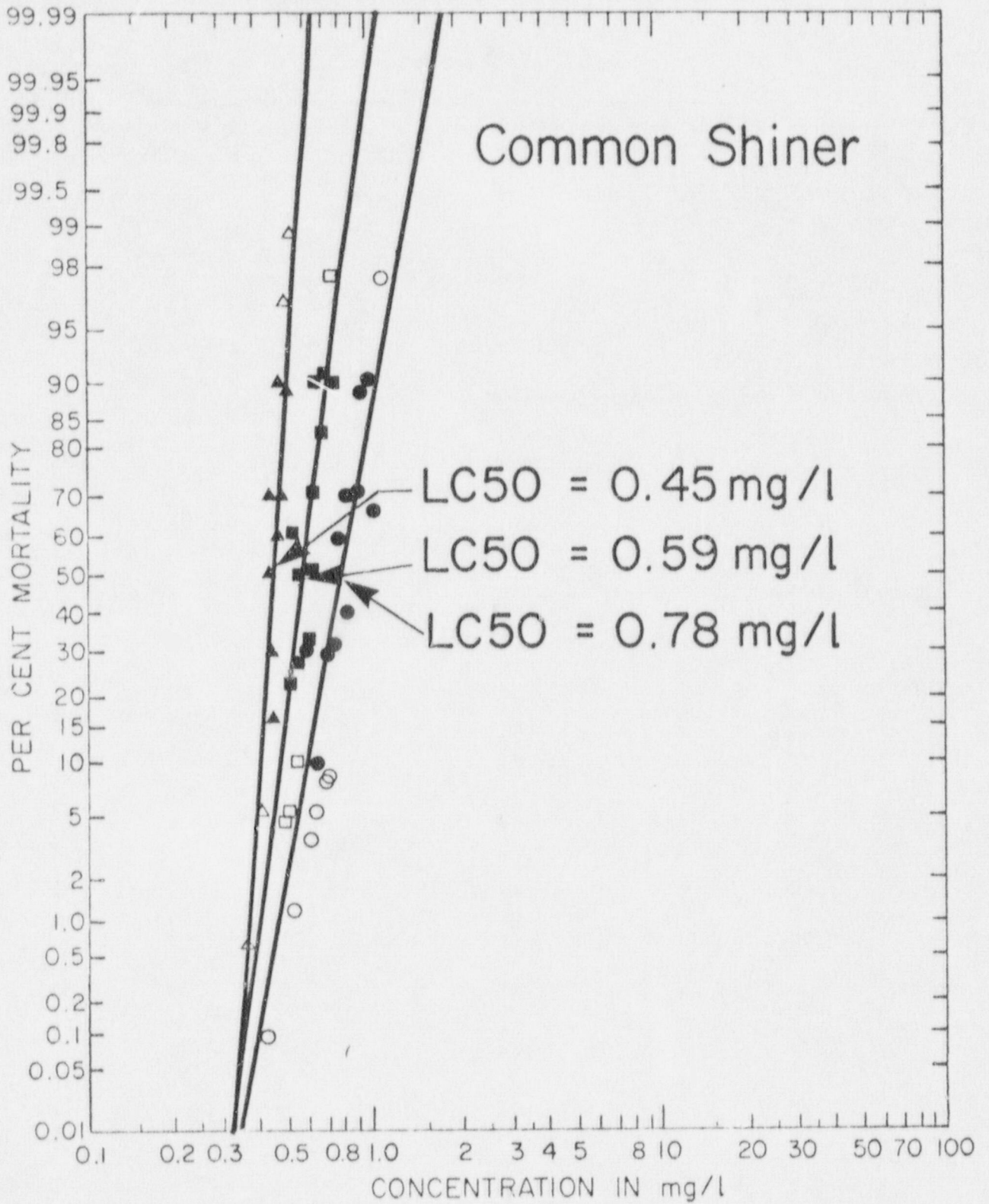

Figure 4. Results of quadruple 40-minute exposures of common shiners at 10 (circles), 20 (squares) and 30C (triangles) to residual chlorine. Mortality determined 48 hours later in unchlorinated water. Solid symbols represent observed mortalities; open symbols represent concentrations where 0% and 100% mortality data were transformed.

Table 3. Summary of parameters observed during quadruple 40-minute exposures of common shiner to residual chlorine.

Test Temperature	10C	20C	30C
Total length (mm) average (range)	53 (41-75)	55 (44-72)	54 (40-80)
Average weight (g)	1.29	1.29	1.44
Number of fish tested	205	197	208
pH (range)	(8.09-8.30)	(8.10-8.27)	(8.15-8.42)
Temperature (C) average (range)	10.5 (9.1-11.9)	19.7 (19.1-20.3)	29.7 (28.3-31.0)
D.O. (mg/liter) average (range)	10.5 (8.2-11.4)	8.8 (7.5-9.3)	7.6 (7.2-7.9)
Monochloramine (%) average (range)	99 (94-100)	96 (57-100)	96 (85-100)
No mortality (mg/liter)	0.54	0.50	0.38
100% mortality (mg/liter)	1.09	0.75	0.52
Safe factor	0.69	0.85	0.84
LC50 (mg/liter as TRC) (95% confidence interval)	0.78 (0.73-0.83)	0.59 (0.56-0.62)	0.45 (0.41-0.49)
Slope function (95% confidence interval)	1.25 (1.20-1.30)	1.18 (1.12-1.24)	1.09 (1.07-1.12)

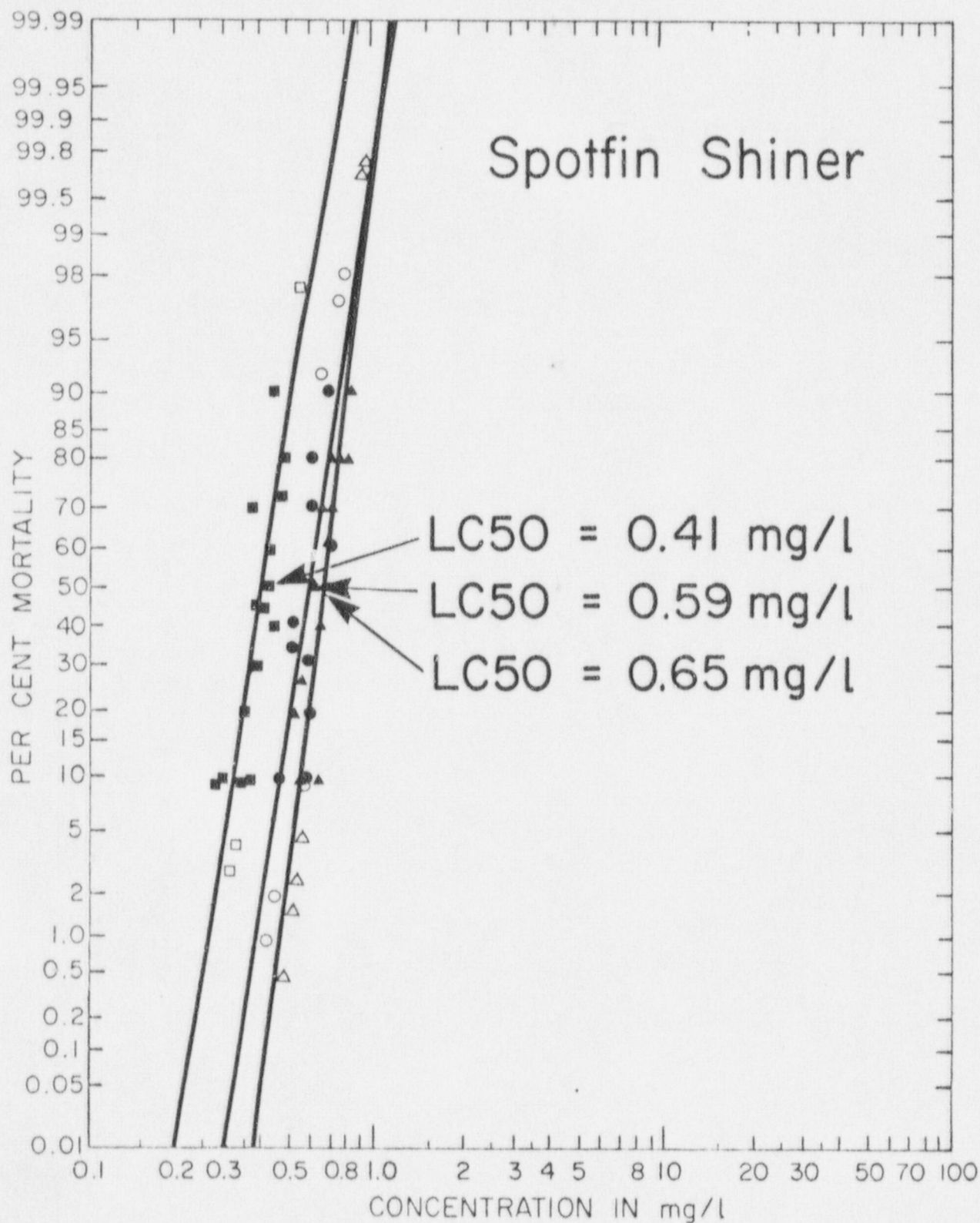

Figure 5. Results of quadruple 40-minute exposures of spotfin shiner at 10 (triangles), 20 (circles) and 30C (squares) to residual chlorine. Mortality determined 48 hours later in unchlorinated water. Solid symbols represent observed mortalities; open symbols represent concentrations where 0% and 100% mortality data were transformed.

Table 4. Summary of parameters observed during quadruple 40-minute exposures of spotfin shiner to residual chlorine.

Test Temperature	10C	20C	30C
Total length (mm) average (range)	54 (43-66)	54 (40-65)	51 (42-67)
Average weight (g)	1.31	1.26	1.24
Number of fish tested	240	220	190
pH (range)	(8.07-8.38)	(8.33-8.62)	(8.36-8.61)
Temperature (C) average (range)	10.3 (8.8-12.0)	20.1 (19.5-21.0)	29.7 (28.9-30.6)
D.O. (mg/liter) average (range)	9.9 (8.1-11.2)	8.3 (7.6-9.6)	7.6 (6.8-8.2)
Monochloramine (%) average (range)	98 (90-100)	95 (65-100)	94 (84-100)
No mortality (mg/liter)	0.52	0.45	a
100% mortality (mg/liter)	0.90	0.75	0.54
Safe factor	0.80	0.76	b
LC50 (mg/liter as TRC) (95% confidence interval)	0.65 (0.63-0.68)	0.59 (0.55-0.64) ^c	0.41 (0.38-0.42)
Slope function (95% confidence interval)	1.15 (1.12-1.18)	1.20 (1.09-1.32) ^c	1.21 (1.15-1.27)

^aCould not be calculated because some mortality occurred at the lowest test concentration.

^bSafe factor could not be calculated because the no mortality concentration was not established.

^cConfidence interval adjusted to compensate for significantly heterogeneous data (Litchfield and Wilcoxon (1949)).

fourth exposure and 11% occurred more than 24 hours after the fourth exposure. Spotfin shiner mortalities were extremely rapid at 20C where 81% of the mortalities occurred after only one exposure (Table 2).

Bluegill

Bluegills were much more resistant to monochloramine than the shiners. LC50 values were 3.00, 1.72, and 1.23 mg/l at 10, 20 and 30C, respectively. Even at 30C the no mortality concentration was 1.07 mg/l (Fig. 6 and Table 5). Six percent of the bluegills recovered at 10C after equilibrium loss but only 2% recovered at 20 and 30C. Mortalities were more delayed than in the shiners with less than 20% occurring before the third exposure at any of the temperatures (Table 2). Mortalities were somewhat more rapid at the warmer temperatures. The percentages of mortalities occurring within 24 hours of exposure were 67, 83, and 90% at 10, 20 and 30C, respectively (Table 2).

Carp

Carp, like bluegills, were highly resistant to monochloramine. LC50 values were 2.37, 1.82, and 1.50 mg/l at 10, 20 and 30C, respectively (Fig. 7 and Table 6). At 10, less than 3% of the carp recovered after equilibrium loss, but at 20 and 30C the percentage of fish recovering increased to 19% and 11%, respectively. Carp mortalities occurred more rapidly than in the bluegills but occurred more slowly than in the shiners. Mortalities typically began after the second exposure and were then scattered during the next two exposures and throughout the first 24 hours following the fourth exposure. Mortalities were more rapid at 30C where 75% of the

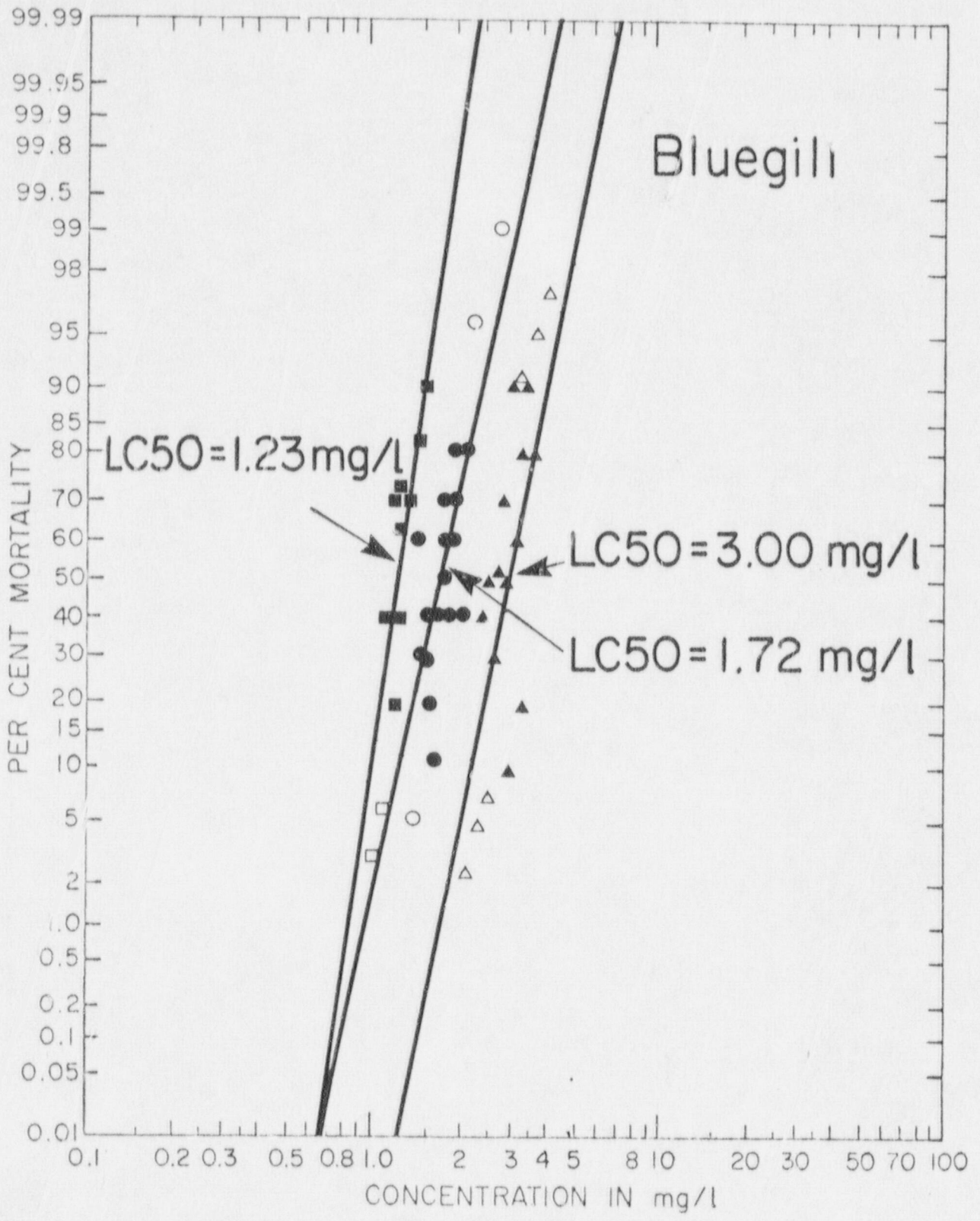

Figure 6. Results of quadruple 40-minute exposures of bluegills at 10 (triangles), 20 (circles), and 30C (squares) to residual chlorine. Mortality determined 48 hours later in unchlorinated water. Solid symbols represent observed mortalities; open symbols represent concentrations where 0% and 100% mortality data were transformed.

Table 5. Summary of parameters observed during quadruple 40-minute exposures of bluegill to residual chlorine.

Test Temperature	10C	20C	30C
Total length (mm) average (range)	98 (75-117)	101 (68-132)	104 (74-135)
Average weight (g)	10.7	17.8	19.8
Number of fish tested	290	249	199
pH (range)	(8.08-8.39)	(8.04-8.32)	(7.93-8.27)
Temperature (C) average (range)	10.2 (9.7-10.9)	20.1 (18.8-21.3)	29.9 (28.6-31.1)
D.O. (mg/liter) average (range)	10.7 (9.7-11.6)	9.1 (8.6-9.6)	7.4 (6.7-8.1)
Monochloramine (%) average (range)	91 (52-88)	92 (34-100)	98 (91-100)
No mortality (mg/liter)	2.35	1.35	1.07
100% mortality (mg/liter)	3.73	2.24	a
Safe factor	0.78	0.78	0.87
LC50 (mg/liter as TRC) (95% confidence interval)	3.00 (2.75-3.33) ^b	1.72 (1.62-1.82)	1.23 (1.17-1.29)
Slope function (95% confidence interval)	1.27 (1.09-1.47) ^b	1.29 (1.19-1.39)	1.19 (1.08-1.31)

^aNone of the concentrations tested consistently caused 100% mortality.

^bConfidence interval adjusted to compensate for significantly heterogeneous data (Litchfield and Wilcoxon, 1949).

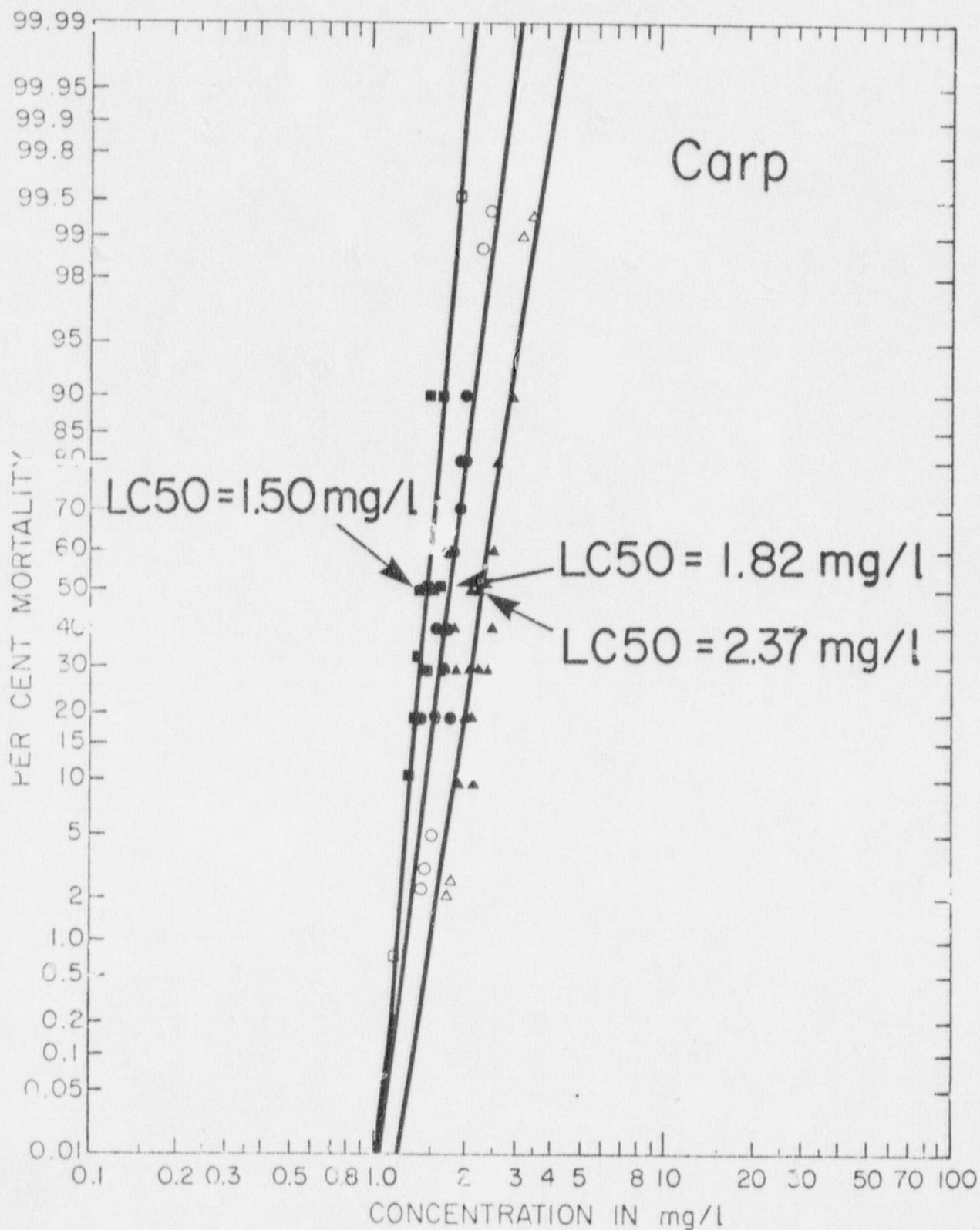

Figure 7. Results of quadruple 40-minute exposures of carp at 10 (triangles), 20 (circles), and 30C (squares) to residual chlorine. Mortality determined 48 hours later in unchlorinated water. Solid symbols represent observed mortalities; open symbols represent concentrations where 0% and 100% mortality data were transformed.

Table 6. Summary
carp to

ved during quadruple 40-minute exposures of

Test Temperature	10C	20C	30C
Total length (mm) average (range)	81 (55-100)	72 (60-101)	85 (62-118)
Average weight (g)	5.96	5.07	8.06
Number of fish tested	240	190	140
pH (range)	(8.07-8.42)	(8.10-8.39)	(8.10-8.41)
Temperature (C) average (range)	10.4 (9.5-11.4)	19.7 (18.8-21.0)	29.3 (27.4-30.1)
D.O. (mg/liter) average (range)	11.2 (10.7-11.8)	9.2 (8.6-9.7)	7.6 (7.0-8.3)
Monochloramine (%) average (range)	95 (54-98)	93 (38-100)	93 (86-99)
No mortality (mg/liter)	1.85	a	1.25
100% mortality (mg/liter)	3.24	2.38	1.96
Safe factor	0.78	b	0.83
LC50 (mg/liter as TRC) (95% confidence interval)	2.37 (2.26-2.49)	1.82 (1.75-1.89)	1.50 (1.45-1.55)
Slope function (95% confidence interval)	1.19 (1.14-1.24)	1.15 (1.11-1.20)	1.10 (1.08-1.12)

^aCould not be calculated because some mortality occurred at the lowest test concentration.

^bSafe factor could not be calculated because the no mortality concentration was not established.

mortalities occurred before the fourth exposure compared to 38 and 36 percent at 10 and 20C, respectively (Table 2).

White Bass

White bass also were relatively resistant to monochloramine. LC50 values were 2.87, 1.80, and 1.15 mg/l at 10, 20 and 30C respectively (Fig. 8 and Table 7). The lowest no mortality concentration was 0.78 mg/l at 30C (Table 7). The slope of the 10C toxicity curve was statistically different compared to the slopes at 20 and 30C (Fig. 8). White bass exhibiting equilibrium loss after exposure to monochloramine did not recover. Mortalities occurred more rapidly at the warmer temperatures. At 10C, 56% of the mortalities occurred before the fourth exposure (Table 2). At 20C, 68% of the mortalities occurred before the fourth exposure (Table 2). Mortalities occurred most rapidly at 30C where 65% occurred after only one exposure, 83% after two exposures and 87% after three exposures (Table 2).

Sauger

Sauger were more resistant than the shiners, but considerably more sensitive than bluegill, carp or white bass. Sauger LC50 values were 1.14, 0.68, and 0.71 mg/l at 10, 20, and 30C, respectively (Fig. 9 and Table 8). The 20 and 30C values were not significantly different. At both 20 and 30C the no mortality concentrations were approximately 0.5 mg/l (Table 8). The slope of the toxicity curve was significantly steeper at 30C than at 10 or 20C. Sauger did not recover following loss of equilibrium. Mortalities occurred much more rapidly at the warmer test temperatures. The percentage of mortalities which occurred after two exposures were 32, 95, and 89% at 10, 20, and 30C, respectively (Table 2). Mortalities were especially rapid at 20C where 80% occurred after

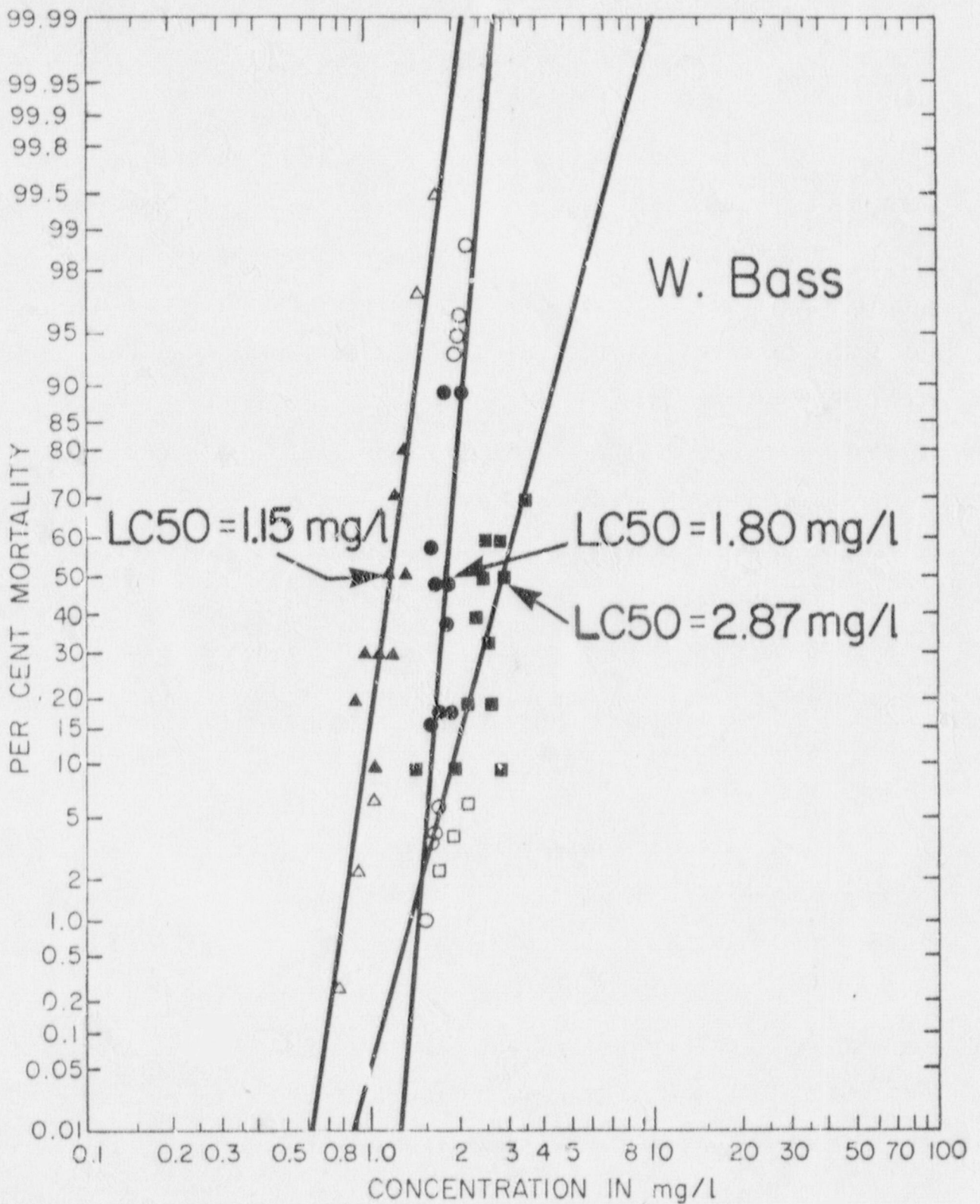

Figure 8. Results of quadruple 40-minute exposures of W. Bass at 10 (squares), 20 (circles), and 30 (triangles) to residual chlorine. Mortality determined 48 hours later in unchlorinated water. Solid symbols represent observed mortalities; open symbols represent concentrations where 0% or 100% mortality data were transformed.

Table 7. Summary of parameters observed during quadruple 40-minute exposures of white bass to residual chlorine.

Test Temperature	10C	20C	30C
Total length (mm) average (range)	107 (89-155)	156 (129-200)	103 (75-132)
Average weight (g)	15.2	47.6	11.0
Number of fish tested	180	225	170
pH (range)	(8.00-8.30)	(7.95-8.32)	(8.02-8.26)
Temperature (C) average (range)	9.9 (8.9-13.0)	20.4 (19-21.4)	29.4 (28.2-31.0)
D.O. (mg/liter) average (range)	9.8 (7.2-12.8)	8.8 (7.6-9.4)	7.5 (6.5-9.2)
Monochloramine (%) average (range)	100 (97-100)	99 (93-100)	100 (96-100)
No mortality (mg/liter)	a	1.45	0.78
100% mortality (mg/liter)	b	2.08	1.47
Safe factor	c	0.81	0.68
LC50 (mg/liter as T ₁₀ C) (95% confidence interval)	2.87 (2.63-3.14)	1.80 (1.74-1.86)	1.15 (1.10-1.21)
Slope function (95% confidence interval)	1.40 (1.23-1.58)	1.12 (1.09-1.16)	1.18 (1.14-1.23)

^aCould not be calculated because some mortality occurred at the lowest test concentration.

^bNone of the concentrations tested consistently caused 100% mortality.

^cSafe factor could not be calculated because the no mortality concentration was not established.

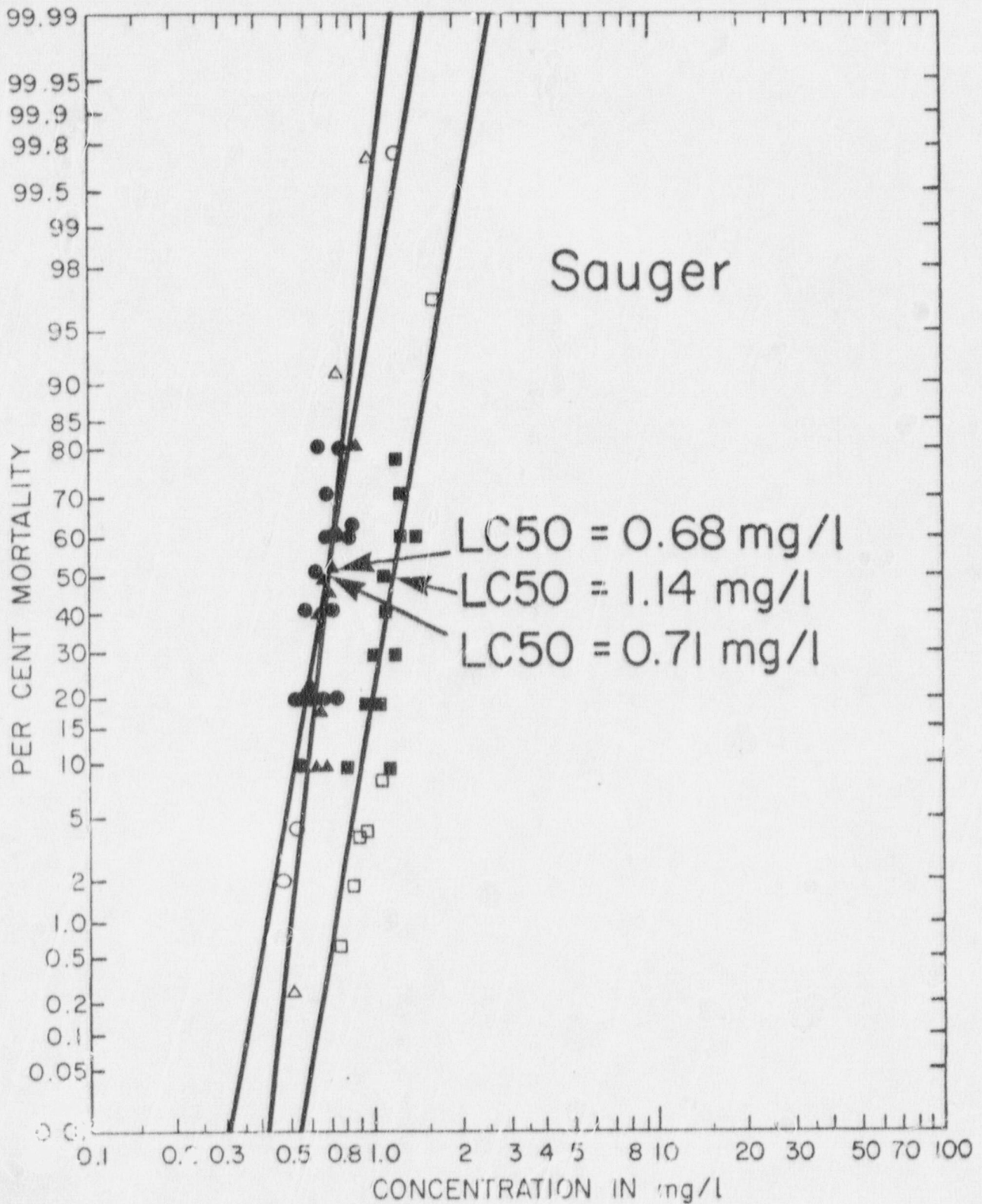

Figure 9. Results of quadruple 40-minute exposures of Sauger at 10 (squares), 20 (circles), and 30C (triangles) to residual chlorine. Mortality determined 48 hours later in unchlorinated water. Solid symbols represent observed mortalities; open symbols represent concentrations where 0% or 100% mortality data were transformed.

Table 8. Summary of parameters observed during quadruple 40-minute exposures of sauger to residual chlorine.

Test Temperature	10C	20C	30C
Total length (mm) average (range)	62 (48-74)	54 (47-67)	81 (58-110)
Average weight (g)	1.67	0.81	3.58
Number of fish tested	229	227	159
pH (range)	(8.16-8.32)	(8.03-8.32)	(7.96-8.45)
Temperature (C) average (range)	10.2 (9.0-11.5)	20.5 (18.9-21.8)	29.4 (27.7-30.3)
D.O. (mg/liter) average (range)	10.5 (9.5-11.5)	8.6 (7.3-9.4)	6.9 (6.0-7.6)
Monochloramine (%) average (range)	100 (99-100)	100 (89-100)	99 (85-100)
50% mortality (mg/liter)	0.75	0.49	0.53
100% mortality (mg/liter)	1.54	1.15	0.98
Safe factor	0.66	0.72	0.75
LC50 (mg/liter as TRC) (95% confidence interval)	1.14 (1.08-1.20)	0.68 (0.65-0.71)	0.71 (0.68-0.74)
Slope function (95% confidence interval)	1.23 (1.16-1.30)	1.24 (1.19-1.30)	1.14 (1.11-1.18)

only one exposure (Table 2).

Channel Catfish

Except for the shiners, the channel catfish was the most sensitive species we tested. LC50 values were 0.78, 0.65, and 0.67 at 10, 20, and 30C, respectively (Fig. 10 and Table 9). It should be noted that the 10C fish were later found to be anemic as compared to the healthy fish used at 20 and 30C. This may have influenced the LC50 value at 10C. The 20 and 30C LC50 values were not significantly different. Catfish, like sauger, had 20 and 30C no mortality concentrations of approximately 0.5 mg/l. Catfish did not recover after loss of equilibrium. Mortality patterns were similar at 10 and 20C where about one-third of the fish died before the fourth exposure (Table 2). However, mortalities were more rapid at 30C. Fifty-three percent occurred after only one exposure and 73% occurred before the fourth exposure (Table 2).

Drum

Drum were one of the more resistant species to monochloramine. LC50 values were 2.45 and 1.75 mg/l at 10 and 20C, respectively (Fig. 11 and Table 20). Only 1% of the drum recovered following loss of equilibrium. Mortalities were considerably more rapid at 20C than at 10C. At 10C, 13% occurred before the fourth exposure compared to 70% at 20C (Table 2). Because of lack of fish only four concentrations were tested at 30C. Three concentrations between 0.5 and 0.9 mg/l caused no mortality. The fourth concentration of 1.05 mg/l caused 25% mortality, suggesting that the LC50 value at 30C is greater than 1.05 mg/l.

White Suckers

White suckers, like the sauger, were somewhat intermediate

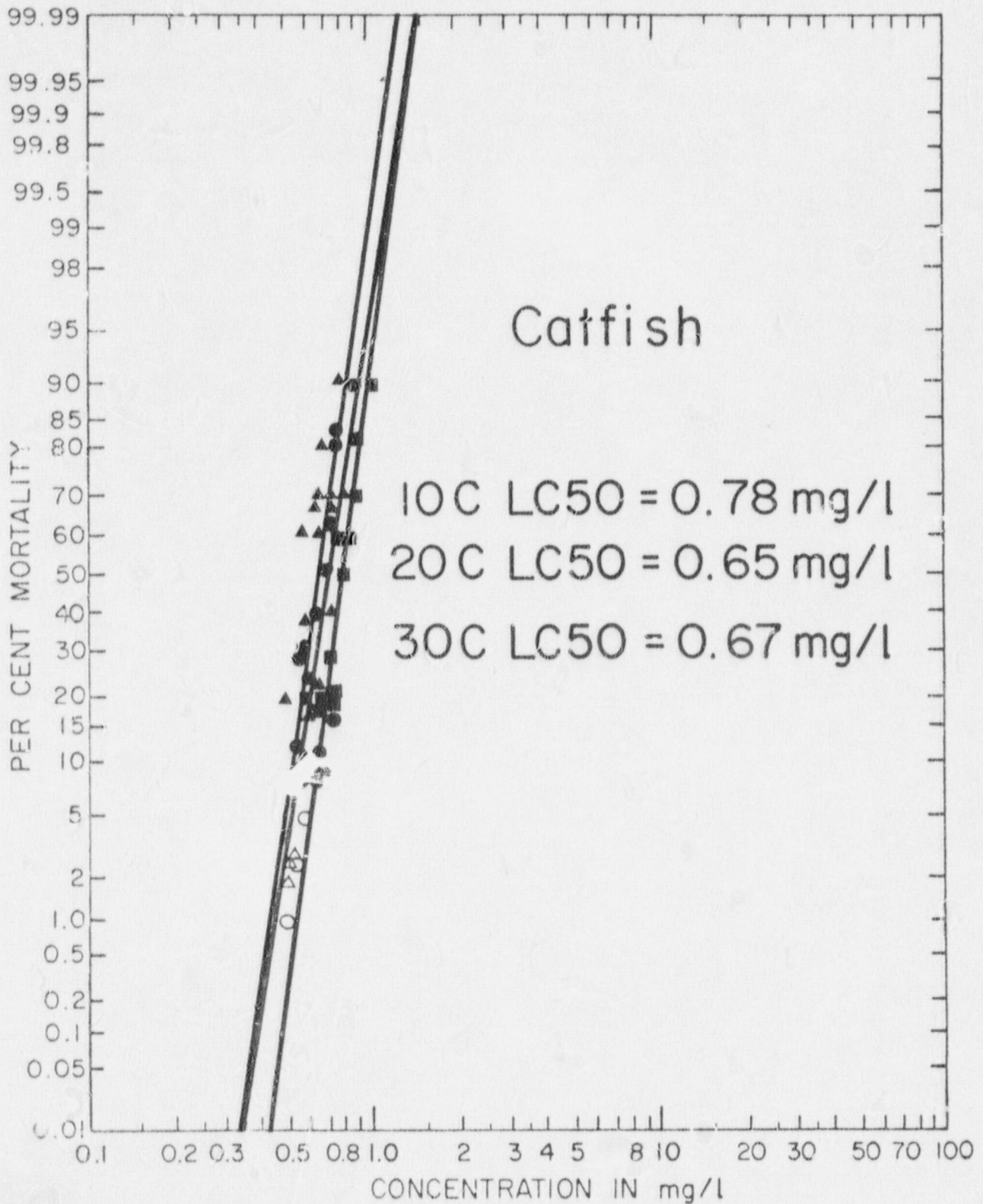

Figure 10. Results of quadruple 40-minute exposures of Catfish at 10 (squares), 20 (triangles), and 30C (circles) to residual chlorine. Mortality determined 48 hours later in unchlorinated water. Solid symbols represent observed mortalities; open symbols represent concentrations where 0% or 100% mortality data were transformed.

Table 9. Summary of parameters observed during quadruple 40-minute exposures of channel catfish to residual chlorine.

Test Temperature	10C	20C	30C
Total length (mm) average (range)	130 (100-199)	135 (108-177)	144 (112-215)
Average weight (g)	15.6	19.0	23.9
Number of fish tested	210	216	175
pH (range)	(8.07-8.40)	(7.97-8.35)	(7.68-8.34)
Temperature (C) average (range)	10.2 (8.5-11.5)	20.4 (19.8-21.1)	29.5 (27.7-30.9)
D.O. (mg/liter) average (range)	10.9 (10-11.5)	8.8 (7.4-9.6)	6.9 (5.8-8.5)
Monochloramine (%) average (range)	100 (98-100)	100 (92-100)	99 (87-100)
No mortality (mg/liter)	a	0.49	0.53
100% mortality (mg/liter)	b	b	b
Safe factor	c	0.75	0.79
LC50 (mg/liter as TRC) (95% confidence interval)	0.78 ^d (0.75-0.82)	0.65 (0.62-0.67)	0.67 (0.65-0.71)
Slope function (95% confidence interval)	1.18 (1.14-1.22)	1.19 (1.12-1.26)	1.19 (1.10-1.29)

^aCould not be calculated because some mortality occurred at the lowest test concentration.

^bNone of the concentrations tested consistently caused 100% mortality.

^cSafe factor could not be calculated because the no mortality concentration was not established.

^dDPD measurements used to calculate LC50.

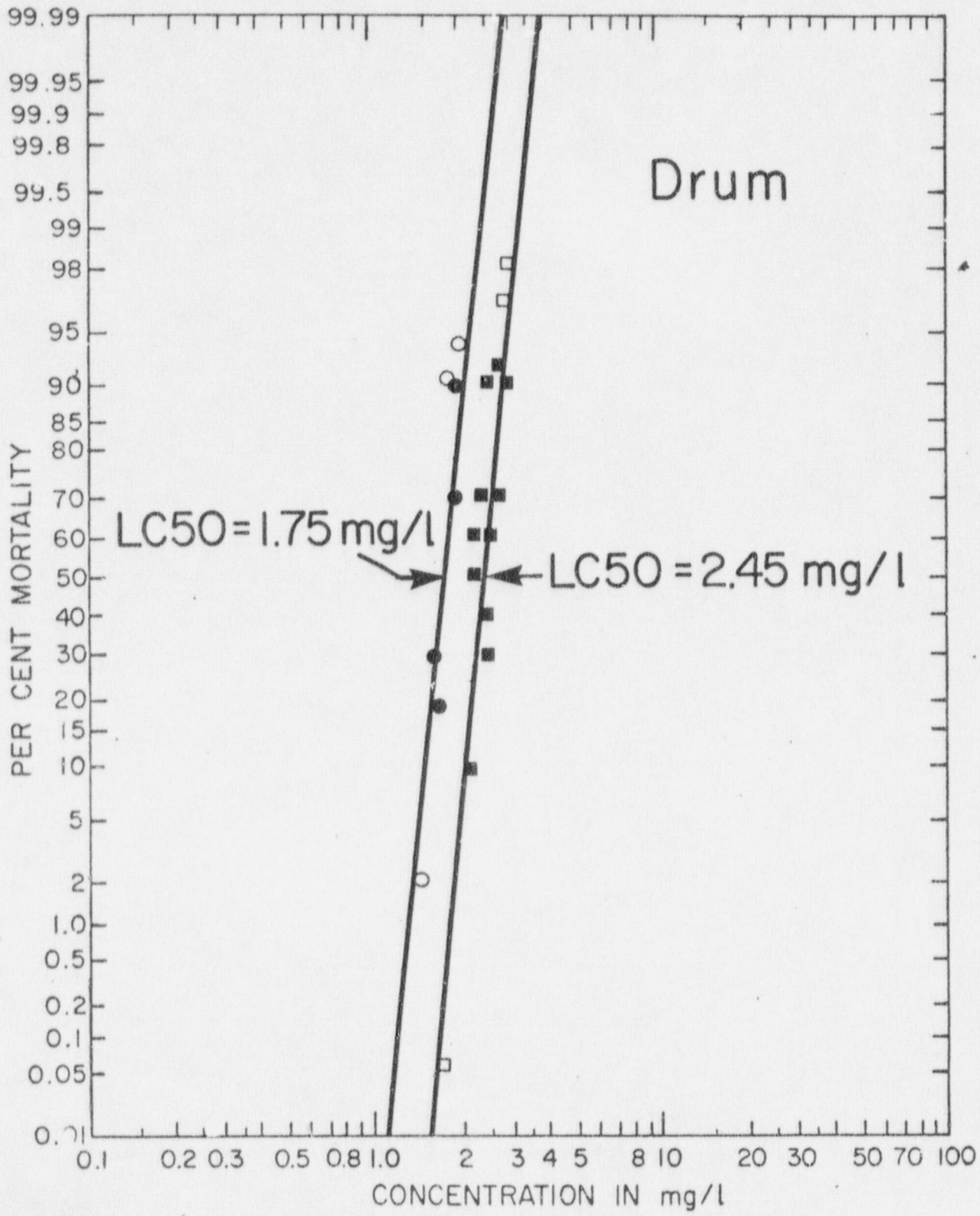

Figure 11. Results of quadruple 40-minute exposures of Drum at 10 (squares) and 20°C (circles) to residual chlorine. Mortality determined 48 hours later in unchlorinated water. Solid symbols represent observed mortalities; open symbols represent concentrations where 0% or 100% mortality data were transformed.

Table 10. Summary of parameters observed during quadruple 40-minute exposures of freshwater drum to residual chlorine.

Test Temperature	10C	20C
Total length (mm) average (range)	107 (75-138)	95 (68-122)
Average weight (g)	7.3	6.9
Number of fish tested	150	90
pH (range)	(8.09-8.38)	(8.09-8.31)
Temperature (C) average (range)	10.3 (9.6-12.0)	20.0 (19.3-21.3)
D.O. (mg/liter) average (range)	*	7.9 (6.3-10.0)
Monochloramine (%) average (range)	100 (100-100)	100 (97-100)
No mortality (mg/liter)	1.73	1.48
100% mortality (mg/liter)	2.84	1.94
Safe factor	0.71	0.85
LC50 (mg/liter as TRC) (95% confidence interval)	2.45 (2.37-2.53)	1.75 (1.67-1.83)
Slope function (95% confidence interval)	1.13 (1.10-1.16)	1.13 (1.09-1.17)

* D.O. values not measured because of instrument failure.

in their response to monochloramine. LC50 values were 1.09, 0.73 and 0.36 mg/l at 10, 20 and 27C, respectively (Fig. 12 and Table 11). A significant amount of heterogeneity was found in the 10C data (Table 11). Only 1% of the white suckers recovered after loss of equilibrium. Mortality patterns were similar at 10 and 20C, with about 50% of the mortalities occurring before the third exposure and the other 50% being scattered throughout the observation period. However, mortalities were considerably more rapid at 27C where 67% occurred after only one exposure (Table 2). The series originally planned for 30C was conducted at 27C when it was found that at 30C fish were dying in the holding tanks from temperature stress. The upper lethal temperature of the white sucker ranges from 29 - 31C depending on the age of the fish and their thermal history (Brett 1946; Hart 1947).

Behavioral Observations

During the chlorine exposure period all the species typically exhibited an initial phase during which they restlessly swam around the tank and frequently came to the surface to gulp for air. This behavior was quickly replaced by a general lethargy which lasted throughout the exposure period. Between exposures normal behavior quickly returned. The lethargic behavior was especially pronounced in carp and white suckers. They usually rested on the bottom of the tank frequently lying on their sides. During this time opercular movement almost ceased and they appeared dead to the casual observer.

Dying fish typically sank to the bottom of the tank without exhibiting convulsive movements. Respiration gradually ceased and they quietly expired. In death most fish assumed a natural

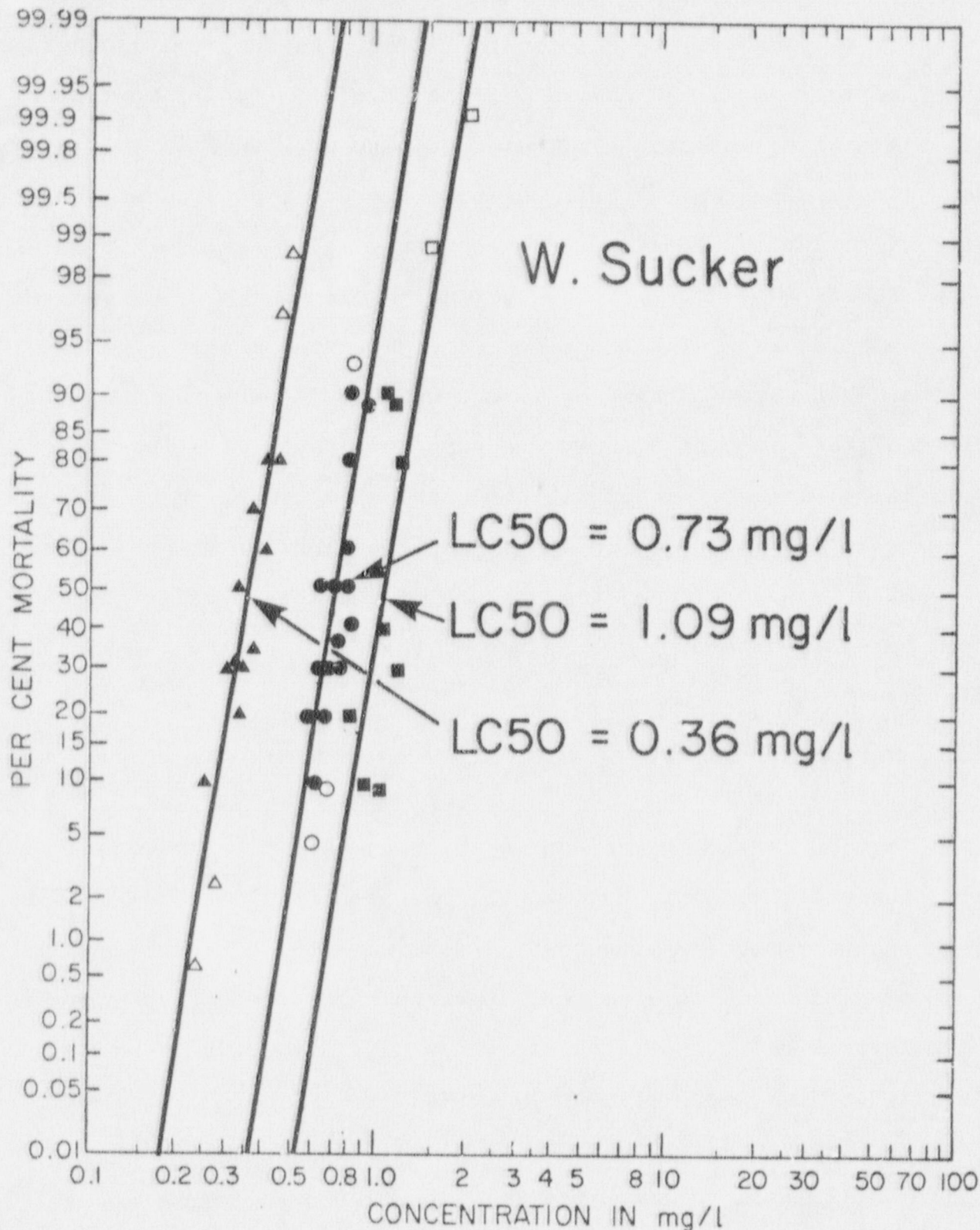

Figure 12. Results of quadruple 40-minute exposures of W. Sucker at 10 (squares), 20C (circles) and 27C (triangles) to residual chlorine. Mortality determined 48 hours later in unchlorinated water. Solid symbols represent observed mortalities; open symbols represent concentrations where 0 and 100% mortality data were transformed.

Table 11. Summary of parameters observed during quadruple 40-minute exposures of white sucker to residual chlorine.

Test Temperature	10C	20C	27C
Total length (mm) average (range)	114 (97-210)	112 (72-138)	94 (80-108)
Average weight (g)	11.3	11.4	6.1
Number of fish tested	130	213	180
pH (range)	(8.07-8.23)	(8.13-8.31)	(7.77-8.45)
Temperature (C) average (range)	10.0 (8.9-11.2)	20.0 (19.1-20.8)	26.7 (25.9-28.2)
D.O. (mg/liter) average (range)	9.2 (7.0-12.6)	9.6 (8.2-10.2)	6.7 (5.6-8.2)
Monochloramine (%) average (range)	100 (99-100)	100 (100-100)	97 (96-98)
No mortality (mg/liter)	a	a	0.24
100% mortality (mg/liter)	1.52	b	0.51
Safe factor	c	c	0.67
LC50 (mg/liter as TRC) (95% confidence interval)	1.09 (0.96-1.23) ^d	0.73 (0.70-0.76)	0.36 (0.34-0.38)
Slope function (95% confidence interval)	1.21 (1.10-1.33) ^d	1.20 (1.13-1.28)	1.22 (1.15-1.29)

^aCould not be calculated because some mortality occurred at the lowest test concentration.

^bNone of the concentrations tested consistently caused 100% mortality.

^cSafe factor could not be calculated because the no mortality concentration was not established.

^dConfidence interval adjusted to compensate for significantly heterogeneous data (Litchfield and Wilcoxon, 1949).

posture, however, sauger frequently died with mouth agape and gills flared.

Lethal monochloramine concentrations caused large losses of mucus in carp and bluegills. Most of the mucus loss occurred during the third and fourth exposures. After the fourth exposure carp often had strips of mucus hanging from their bodies and in severe cases the water became cloudy because of suspended mucus. Nonlethal monochloramine concentrations did not elicit this loss of mucus. This phenomenon was not observed in the other species.

DISCUSSION

To our knowledge no other intermittent chlorine toxicity studies have been conducted on spotfin shiners, common shiners, freshwater drum, or white bass. Fandrei (1977) reported 30-minute LC50 values for emerald shiners of 0.28 and 0.85 mg/l at 25 and 10C, respectively. Although Fandrei (1977) only reports TRC concentration, his experiments were conducted in Lake Superior water where free chlorine was probably the principal chlorine form present and not monochloramine as with our study. Heath (1977) found carp to be highly resistant to monochloramine. He reported a 96-hour LC50 of 1.72 mg/l for carp which had been exposed 45 minutes to monochloramine at 6C three times daily. This compares well with our 10C LC50 of 2.37 mg/l which was based on one day of quadruple exposures of carp to monochloramine. Although we are not aware of any short term studies on bluegills using monochloramine, the results of intermittent free chlorine tests (Bass and Heath 1977; Larsen et al. 1978) and 96-hour continuous exposure chloramine bioassays (Ward et al. 1976) support our finding that bluegills

are resistant to chlorine. Heath (1977) found catfish to be the most sensitive of five species he exposed to monochloramine. Based on six 45-minute exposures he reported an LC50 of 0.45 mg/l at 24C. This compares well with our 20C LC50 value of 0.65 mg/l which was based on quadruple 40-minute exposures. Dent (1974) reported that catfish which received six 20-30 minute chlorine exposures during a 48-hour period had an LC50 value of 1.1 mg/l at about 18C. Dent did not specify which chlorine species were present. Fobes (1971) reported that 1 mg/l of chlorine was toxic to white suckers in one hour and Arthur et al. (1975) reported that at 16C white suckers had a one hour LC50 value greater than 0.56 mg/l. Although no other chlorine toxicity tests have been conducted on the sauger, several authors have tested its close relative the walleye (Stizostedion vitreum). Arthur et al. (1975) and Ward et al. (1976) both reported that the walleye was intermediate in its response to chlorine compared to the sensitive shiner-salmonid group and the resistant centrarchid group. This parallels our findings on the sauger.

Temperature Effects

All ten species showed an inverse relationship between temperature and resistance to monochloramine. Cairns et al. (1975) concluded that there was not enough information available to accurately predict the effect of temperature on chlorine toxicity. Brooks and Seegert (1976) suggested a general trend of increased sensitivity to chlorine at higher temperatures. The rapid expansion of information relative to intermittent chlorine toxicity permits us to now make a more definitive statement. Recent data gathered in our laboratory (Brooks and Seegert 1977 a and b;

Seegert and Brooks 1978 b) together with the information presented in this report prove conclusively that the resistance of fish exposed to chlorine for short periods (minutes or hours) is inversely proportional to temperature. The trend for longer exposures (days or weeks) is less clear but it appears that as the total time of exposure increases the importance of temperature on toxicity decreases. LC50 values based on single 30-minute chlorine exposures showed up to an 11-fold change between 10 and 30C (Brooks and Seegert 1977a). In contrast the LC50 values reported here for 160 minutes of total chlorine exposure time showed a maximum change of only 3-fold (Table 11). Heath (1977) reported similar findings in that LC50 values after one day of intermittent chlorine exposures exhibited significant differences due to temperature. However, after one week of intermittent exposures he found that although mortalities occurred more rapidly at higher temperatures LC50 values were unaffected by temperature.

Behavioral Observations

None of the chlorine-sensitive species (e.g., shiners and catfish) ever recovered after equilibrium loss whereas some of the chlorine-resistant species (e.g., bluegills and carp) showed some ability to recover. We previously observed that species sensitive to free chlorine (coho salmon, Oncorhynchus kisutch and rainbow trout, Salmo gairdneri) rarely recovered following equilibrium loss but that yellow perch, Perca flavescens, and spottail shiners, Notropis hudsonius, which are more resistant to free chlorine sometimes recovered at low test temperatures (Brooks and Seegert 1977a; Seegert and Brooks 1978 b). In the current study bluegills followed the pattern for resistant species but carp recovered better at

the warmer test temperatures. The apparent discrepancy may be related to the extreme lethargy exhibited by the carp which led to difficulty in accurately counting the number of individuals exhibiting equilibrium loss.

The extreme lethargy exhibited by the carp and white suckers is an interesting point for speculation. We observed that these species almost ceased opercular movement completely. The gills are frequently mentioned as the site of toxic action by chlorine (Bass et al. 1977) or acting as a point of entry for the chlorine (Kleinow 1977). The cessation of opercular movement would decrease the flow of chlorinated water over the gills and thereby reduce the contact between chlorine and the gill surfaces. Whether this is actually the reason for the extreme lethargy exhibited by the carp and white suckers is unclear. It is also unclear whether the observed lethargy is an active or passive behavioral response.

The mortality pattern (i.e., when the mortalities occurred) following monochloramine exposure varied both inter and intraspecifically. However, in all species mortalities occurred more rapidly at the warmer temperatures. Mortalities in the spotfin and emerald shiner, sauger, and white bass occurred most rapidly. Mortality rates were intermediate for the common shiner, catfish, white sucker, drum and carp, while they were lowest in the bluegill. Although the chlorine sensitive species usually suffered mortalities more rapidly than did the chlorine resistant species there were too many exceptions to consider this a general rule. We did find, however, that the effect of the exposures was more cumulative in resistant species such as carp and bluegill. Six of the 29 groups (spotfin shiner, emerald shiner and sauger at 20C;

white sucker at 27C; white bass and catfish at 30C) tested had high (53-81%) mortalities after only one exposure. The cause of the extremely rapid mortality in these groups is unclear but points up the danger of extrapolating from single to multiple exposure situations.

Mucus loss appears to be a general response of fish exposed to chlorine. The degree to which it occurs is probably influenced by exposure time and concentration, chlorine form, and fish species (Bass et al. 1977; Dandy 1972). In our experiments we only observed excessive mucus secretions during the bluegill and carp experiments after the third or fourth chlorine exposure and it was only evident at lethal monochloramine concentrations. In extreme situations the mucus interfered with our amperometric TRC measurements to produce low readings which may account for the heterogeneity in the 10C bluegill data. The mucus apparently interfered with the iodide (I^-) to iodine (I_2) reaction which takes place when potassium iodide (KI) is added to chlorinated water. The intensity of the yellow color produced by the liberated I_2 can be taken as a qualitative indicator of the monochloramine concentration. Visual observations clearly indicated that the iodide to iodine reaction was not proceeding to completion. The mechanism of this interference is unclear. One additional fact should be added. Corresponding DPD titrimetric measurements which also include an iodide to iodine reaction were not so affected.

Free Chlorine vs. Chloramines

Considerable controversy exists in the literature over the relative toxicities of free and combined chlorine (Brooks and Seegert 1976). Most authors (Merkins 1958; Eren and Langer 1973;

Rosenberger 1971) consider free chlorine to be more toxic and swifter acting. However, others (Westfall 1946; Holland et al. 1960) consider chloramines to be more toxic. Heath (1977) recently found that depending on fish species free chlorine was 3 to 14 times more toxic than monochloramine. Although our study did not directly compare the toxicities of free and combined chlorine several observations are germane to this question. Previous work (Brooks and Seegert 1977 a; Seegert and Brooks 1978 b) in our laboratory indicates that solutions of predominately free chlorine are non-lethal to a number of fish species at concentrations ≤ 0.2 mg/l. In the present study the lowest non-lethal level of monochloramine we determined was 0.21 mg/l. The 0.2 mg/l level for free chlorine is based on a single 30-minute exposure whereas the 0.21 mg/l level for monochloramine is based on 160 minutes of exposure suggesting that free chlorine is more toxic.

A second factor which probably contributes to the confusion over the relative toxicities of free and combined chlorine is that both mono and dichloramine are frequently lumped together as combined chlorine in reporting concentrations when in fact they may have decidedly different toxicities. Chemical studies have shown that the reaction rate of dichloramine with activated carbon is closer to that of free chlorine than monochloramine (Snoeyink & Markus 1973). Similarly, Rosenberger (1971) found that the slopes of the toxicity curves for free chlorine and dichloramine were similar but the curve for monochloramine was significantly different. Some preliminary experiments conducted during our study indicated that dichloramine was considerably more toxic than monochloramine.

Holland (1960) reported dichloramine to be more toxic than either free chlorine or monochloramine. It seems logical therefore to conclude that free chlorine is more toxic than monochloramine but not necessarily more toxic than dichloramine. In any case the inclusion of mono and dichloramine in the same category (i.e., chloramines or combined chlorine) in reporting toxicity data should be avoided.

Sensitive and Resistant Species

The ten species we tested can be divided into "resistant" and "sensitive" groups. The "resistant" group which includes bluegill, drum, white bass, and carp had 20C LC50 values of 1.72 - 1.82 mg/l and 30C LC50 values of 1.15 - 1.50 mg/l. Conversely, the "sensitive" group which includes the three shiner species plus catfish, sauger, and white sucker had 20C LC50 values of 0.51 - 0.73 mg/l and 30C LC50 values which averaged 0.5 mg/l (0.35 - 0.71). There was more than a two fold difference in LC50 values between the two categories. Within the "sensitive" group the shiners were the most sensitive followed by catfish, sauger, and white sucker. Our results support the findings of Ward et al. (1976) who reported shiners to be highly sensitive to chlorine.

Miscellaneous Observations

We found that in most of the species (e.g., catfish, Table 8) slopes of the toxicity curves were similar at each test temperature and that in general slopes were also similar between species. Slope functions ranged from 1.09 to 1.40 but usually were between 1.13 and 1.25 meaning the curves were extremely steep (Tables 1-11, Figures 3-12). We also found that the curves were

steeper at the higher temperatures. Slope functions averaged 1.22, 1.19, and 1.17 at 10, 20 and 30C, respectively.

Catfish showed the smallest range between 10 and 30C LC50 values of the species we tested. This may be partially explainable by the anemia found in the 10C group since the anemia may have lowered 10C LC50 value. In any case, the 10C LC50 value for catfish should be considered conservative.

Safe Levels

We have previously determined a safe factor (S.F. = no mortality concentration divided by the LC50 value) of 0.5 for fish exposed to TRC for 15 to 30 minute periods (Brooks and Seegert 1977 a and b; Seegert and Brooks 1978 b). Thus, in cases where the no mortality level has not been empirically determined we recommended that the 0.5 S.F. be multiplied by the LC50 value to predict a safe chlorine concentration. Safe factors calculated from the data in Tables 1-11 ranged from 0.60 in the emerald shiner at 30C to 0.87 in the bluegill at 30C. Pooled data from all ten species gave an average S.F. of 0.76 suggesting that our previously calculated S.F. of 0.5 is a conservative estimation.

The S.F. value we calculated is higher than most application factors because there was little difference between the no mortality and LC50 concentrations. This caused the slopes of the plotted data to be extremely steep resulting in high safe factors. Similarly, the difference between no mortality and 100% mortality concentrations was small. For instance, common shiners at 30C suffered no mortality at 0.38 mg/l of monochloramine but suffered 100% mortality at 0.52 mg/l (Table 3). Thus a difference of only

0.14 mg/l meant the difference between the shiners all surviving or all dying. The other sensitive species also showed narrow ranges between 0% and 100% mortality concentrations. The need for precisely controlled chlorination practices to avoid fish mortalities is obvious and should be carefully evaluated whenever chlorine regulatory standards are considered.

The lowest no mortality concentration we found was 0.21 mg/l for the emerald shiner. No mortality concentrations for the other "sensitive" species were below 0.5 mg/l (0.38 - 0.49) whereas no mortality concentrations for the resistant species averaged about 1.0 mg/l (0.8 - 1.2). To protect the most sensitive species average monochloramine exposures should not exceed 0.2 mg/l for a period not to exceed 160 minutes. Although we only examined one exposure regime the results of other studies (Brooks and Seegert 1977 a; Mattice and Zittel 1976) have shown that there is an inverse relationship between exposure time and safe chlorine concentrations. Thus, where exposures are likely to be longer than 160 minutes lower concentrations would be necessary; conversely, if exposure periods are shorter than 160 minutes, somewhat higher concentrations would be justified.

LITERATURE CITED

- American Public Health Association. American Water Works Association, and Water Pollution Control Federation. 1976. Standard Methods for the examination of water and wastewater. 14th ed. APHA, Washington, D.C. 1193 pp.
- Arthur, J.W., R. Andrew, V. Mattson, D. Olson, G. Glass, B. Halligan, and C. Walbridge. 1975. Comparative toxicity of sewage-effluent disinfection to freshwater aquatic life. U.S. Environ. Prot. Agency, Ecol. Res. Ser. No. 600/3-75-012, Duluth, Minn. 62 pp.
- Bass, M.L. and A.G. Heath. 1977. Toxicity of intermittent chlorination to bluegill, Lepomis macrochirus: interaction with temperature. Bull. Environ. Contam. and Tox. 17: 416-423.
- _____, C.R. Berry, and A.G. Heath. 1977. Histopathological effects of intermittent chlorine exposure on bluegill (Lepomis macrochirus) and rainbow trout (Salmo gairdneri). Water Res. 11: 731-735.
- Brett, J.R. 1944. Some lethal temperature relations of Algonquin Park fishes. Univ. Toronto Stud. Biol. Ser. 52: Publ. Ont. Fish. Res. Lab., 63: 1-49.
- Brooks, A.S. and G.L. Seegert. 1976. Toxicity of chlorine to freshwater organisms under varying environmental conditions. Pages 277-298 in R.L. Jolley, ed. Proceedings of the conference on environmental impact of water chlorination. Oct. 22-24, Oak Ridge Nat. Lab., Conf. 761096, Oak Ridge, Tenn. October 1975.

- _____ and _____. 1977a. The effects of intermittent chlorination on rainbow trout and yellow perch. Trans. Am. Fish. Soc. 106: 278-286.
- _____ and _____. 1977b. The effects of intermittent chlorination on the biota of Lake Michigan. Special Report #31, Center for Great Lakes Studies, The Univ. Wis.-Milw., Milwaukee, Wis. 167 pp.
- Brungs, W.A. 1973. Effects of residual chlorine on aquatic life. J. Water Pollut. Control Fed. 45: 2180-2193.
- _____. 1976. Effects of wastewater and cooling water chlorination on aquatic life. U.S. Environ. Prot. Agency, Ecol. Res. Ser. No. 66/3-76-098, Duluth, Minn. 46 pp.
- Cairns, J., A.G. Heath, and B.C. Parker. 1975. Temperature influence on chemical toxicity to aquatic organisms. J. Water Pollut. Control Fed. 47: 267-280.
- Dandy, J.W.T. 1972. Activity response to chlorine in the brook trout, Salvelinus fontinalis (Mitchill). Can. J. Zool. 50: 405-410.
- Dent, R.J. 1974. Effects upon fishes of a periodic flushing of electrical power plants boiler tubes with chlorine. M.S. Thesis. Southern Illinois Univ., Edwardsville, Ill. 40 pp.
- Eren, Y. and Y. Langer. 1973. The effect of chlorination on tilapia fish. Bamidgeth Bulletin of Fish Culture in Israel 25: 56-60.
- Fandrei, G.L. 1977. Total residual chlorine: its effect on the emerald shiner Notropis atherinoides (Rafinesque). M.S. Thesis. University of Minnesota.
- Fobes, R.L. 1971. Chlorine toxicity and its effect on gill tissue respiration of the white sucker Catostomus commersoni (Lacepede).

- M.S. Thesis. Michigan State Univ., East Lansing, Michigan.
- Hart, J.S. 1947. Lethal temperature relations of certain fish of the Toronto region. *Trans. Royal Soc. Can.* 41: 57-71.
- Heath, A.G. 1977. Toxicity of intermittent chlorination to freshwater fish: influence of temperature and chlorine form. *Hydrobiologia* 56: 39-47.
- Holland, G.A., J.E. Lasater, E.D. Newmann, and W.E. Eldridge. 1960. Toxic effects of organic and inorganic pollutants on young salmon and trout, p. 198-214. *Res. Bull. No. 5. Dept. of Fish. State of Washington.*
- Kleinow, K. 1977. The effect of 30-minute chlorine exposures on the blood chemistry of rainbow trout and bluegills with a study of chlorine uptake sites in yellow perch. *Univ. of Wis.-Milw., Milwaukee, Wisconsin. M.S. Thesis.*
- Larsen, G., C. Warren, F. Hutchins, L. Lamperti, D. Schlesinger, and W. Seim. 1978. Toxicity of residual chlorine compounds to aquatic organisms. *U.S. EPA Ecol. Res. Ser. (in press).*
- Litchfield, J.T. and F. Wilcoxon. 1949. A simplified method of evaluating dose-effect experiments. *J. Pharm. Exp. Ther.* 96: 99-113.
- Mattice, J.S., and H.E. Zittel. 1976. Site specific evaluation of power plant chlorination. *J. Water Pollut. Control Fed.* 48: 2284-2308.
- Merkens, J.C. 1958. Studies on the toxicity of chlorine and chloramines to the rainbow trout. *Water Waste Treat. J.* 7: 150-151.

- Rosenberger, D.R. 1971. The calculation of acute toxicity of free chlorine and chloramines to coho salmon by multiple regression analysis. M.S. Thesis. Michigan State Univ., East Lansing, Michigan. 33 pp.
- Seegert, G.L., A.S. Brooks, and D.L. Latimer. 1977. The effects of a 30-minute exposure of selected Lake Michigan fishes and invertebrates to residual chlorine. In Loren D. Jensen, ed. Biofouling control procedures: technology and ecological effects. Marcel Dekker, Inc., New York, N.Y. 113 pp.
- _____. and A.S. Brooks. 1978a. Dechlorination of water for fish culture: a comparison of the activated carbon, sulfite reduction, and photochemical methods. J. Fish. Res. Bd. Can. 35: 88-92.
- _____ and _____. 1978b. The effects of intermittent chlorination on coho salmon, alewife, spottail shiner, and rainbow smelt. Trans. Am. Fish. Soc. 107: (in press).
- Snoeyink, V.L. and F.I. Markus. 1973. Chlorine residuals in treated effluents. Illinois Institute for Environmental Quality Doc. 73-15.
- Ward, R.W., R.D. Griffin, G.M. DeGraeve, and R.A. Stone. 1976. Disinfection efficiency and residual toxicity of several wastewater disinfectants. Vol. 1 - Grandville, Michigan U.S. EPA, Cincinnati, Ohio. Ecol. Res. Ser. No. 600/2-75-156.
- Westfall, B.A. 1946. Stream pollution hazards of wood pulp mill effluents. Fishery Leaflet 174. Fish and Wildlife Service, U.S. Department of the Interior.