



LOUISIANA
POWER & LIGHT

317 BARONNE STREET • P. O. BOX 60340
NEW ORLEANS, LOUISIANA 70160 • (504) 595-3100

50-382

March 25, 1988

U.S. Nuclear Regulatory Commission
Washington, D.C. 20555

Attention: D.L. Wigginton

Dear Mr. Wigginton:

In order to aid in upcoming phone conversations, enclosed please find control wiring diagrams for the 4.16kv 3B3-S Bus undervoltage relays (2 sheets), diesel generator B engine control interface and the B sequencer.

Yours very truly,

M. J. Meisner
Nuclear Licensing & Regulatory Affairs
Acting Manager

MJM:ssf

cc (without attachments): R.F. Burski

8803310009 880325
PUR ADOCK 05000382
DCD

A001
1/11

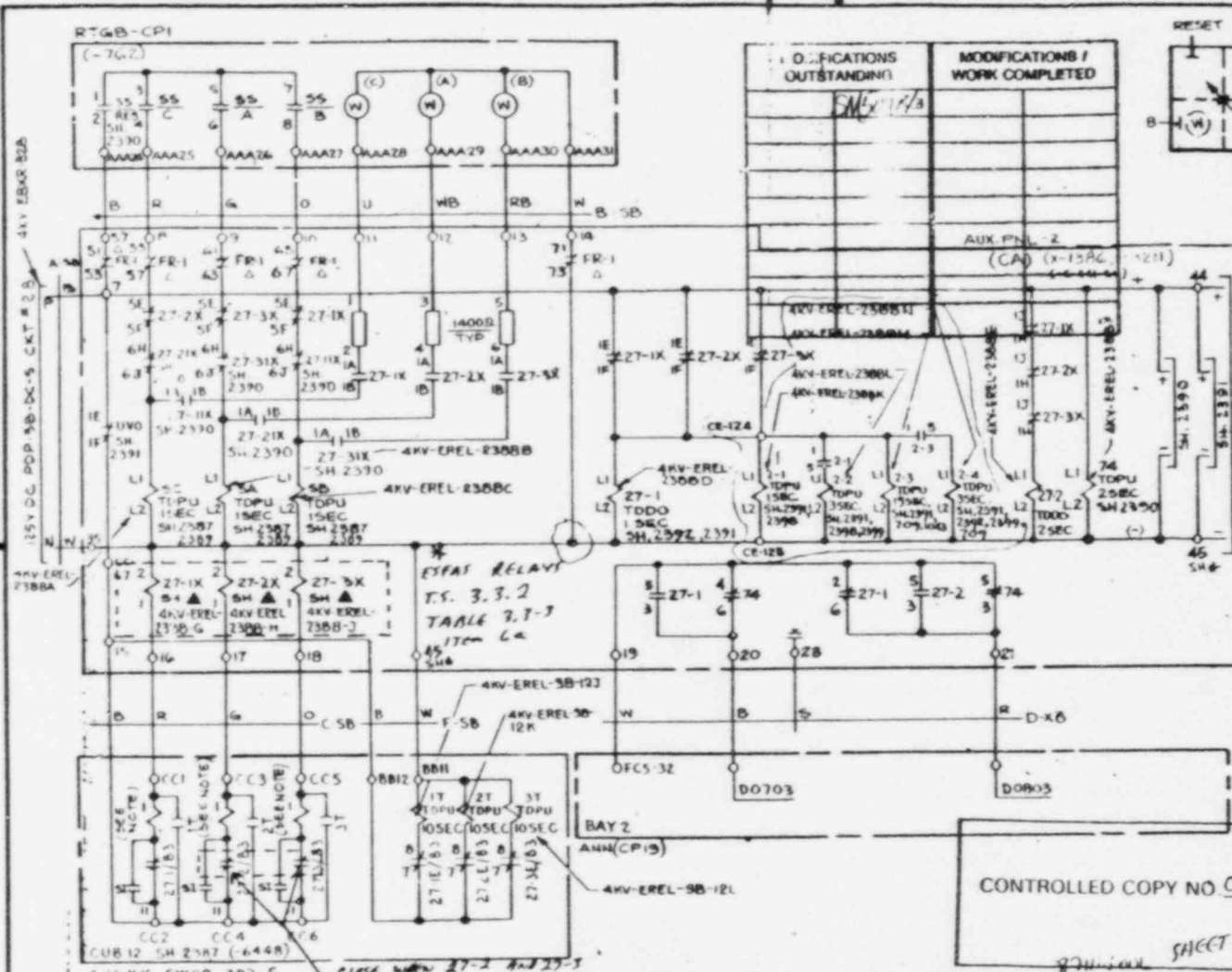

MODIFICATIONS OUTSTANDING	MODIFICATIONS / WORK COMPLETED
SM 2/17/8	

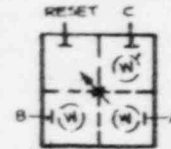

CONTACTS	POSITIONS		
	RESET	C	A
1-2	X		
3-4		X	
5-6			X
7-8			X

TYPE CMC * THIS SHEET MAINTAINED CONTACTS
 Δ SH 2737
 -FR-1 IS LOCATED IN AUX RELAY CAB 12, TRANSFER SW COMPARTMENT

SERVICE	CONTACTS	TYPE MDR RELAY			
		27-1X CWD SH	27-2X CWD SH	27-3X CWD SH	27-4X CWD SH
UNDERVOLTAGE IND.	1A, 1B				
LOSS OF BUS POT AL	1A, 1B				
BLOWN FUSE ALARM	1A, 1B				
SEQUENCER B START	1A, 1B				
DIESEL GEN B START 1	2A, 2B				
DIESEL GEN B START 2	2A, 2B				
DIESEL GEN B BCR CLOSE	2A, 2B				
BUS TIE 3B3-5 TO 3B2	2A, 2B				
EMERG FD WTR PUMP B	3A, 3B				
HPS HI PUMP B	3A, 3B				
LPS HI PUMP B	3A, 3B				
CONT. SPRAY PUMPS	3A, 3B				
AUX CCW PUMP B	3A, 3B				
AUX CCH PUMP B	3A, 3B				
STA 56KV TR 5B3S-5	3A, 3B				
CCW PUMP B	3A, 3B				
STA 56KV TR 5B3S2	3A, 3B				
UV TEST INTERLOCK	3A, 3B				
DIESEL GEN B BKR TRIP	3A, 3B				
RAB NORM EX FAN SB	3A, 3B				
WTR CHILL COMP SB	3A, 3B				
BUS TIE 3B3-5 TO 3B2	3A, 3B				
UV TEST INTERLOCK	3A, 3B				
UV TEST IND.	3A, 3B				

NOTE:
 TARGET COILS (S1) OF UNDERVOLTAGE RELAYS 27-1/B3, 27-2/B3 & 27-3/B3 WILL NOT BE ENERGIZED EVEN IN UNDERVOLTAGE CONDITIONS.

REV	DATE	BY	APPROVED	REV	DATE	BY	APPROVED
1	11/17/77	2	11/17/77
2	12/11/77	3	12/11/77
3	10/7/80	4	9/7/77

EBASCO SERVICES INCORPORATED
 DIV. I & C OR EM
 CH. W. ARNHEITER
 DATE: JAN 25, 1978

LOUISIANA POWER & LIGHT CO.
 WATERFORD S.E. UNIT No.3
 CONTROL WIRING DIAGRAM
 416KV BUS 3B3-S
 UNDERVOLTAGE RELAYS SHEET 2

LOU
 B-4
 SHEET

3 OUT OF 3
 RELAYS TO
 CAUSE EDC START
 CLOCK WORK
 27-1X → 27A
 27-1X → 27B
 27-1X → 27C
 27-1X → 27D

Sheet # 3

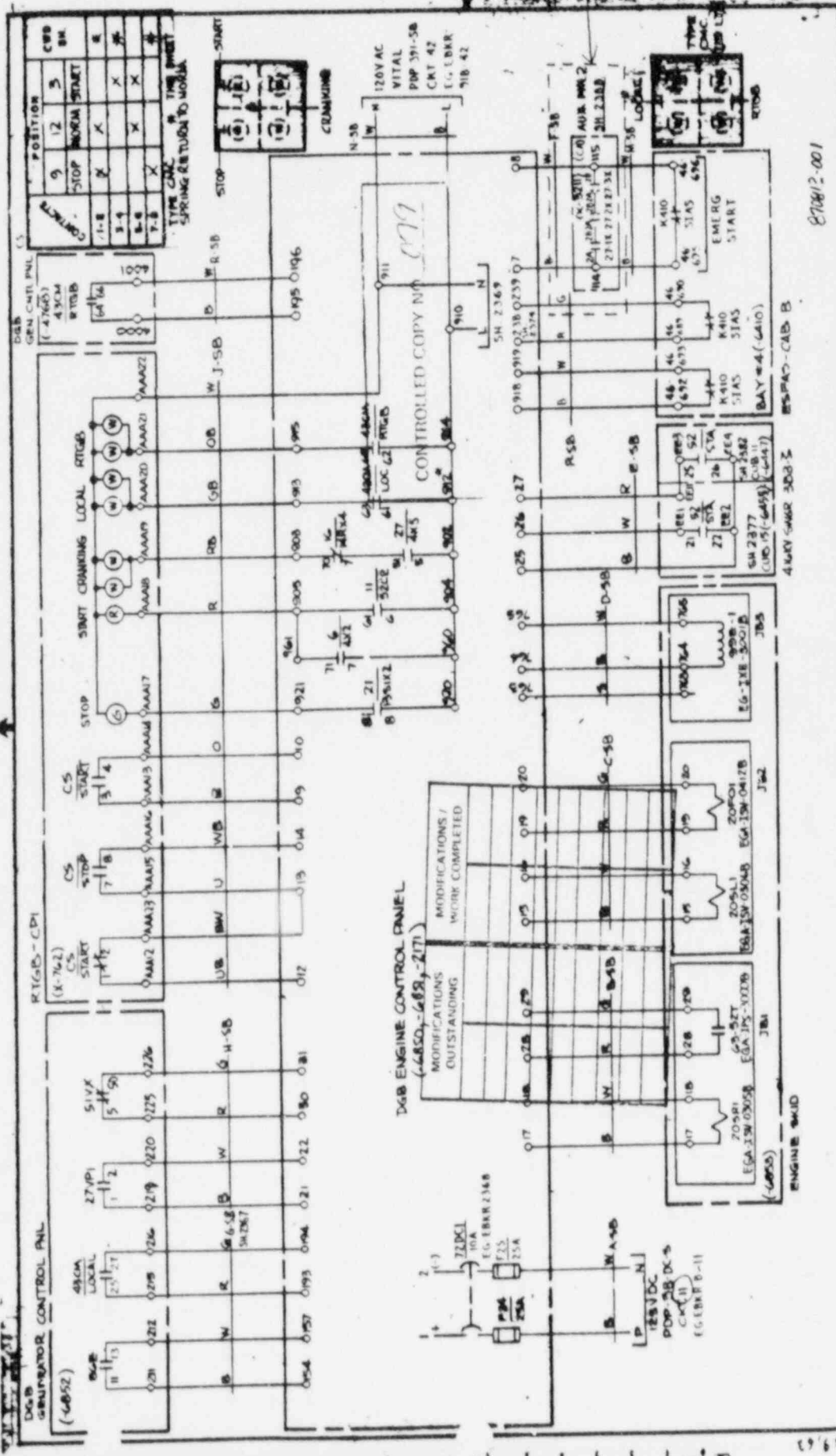

LOUISIANA POWER & LIGHT CO.
 WATERFORD S. E. UNIT No. 3
 CONTROL WIRING DIAGRAM
 DIE-SEL GEN B
 ENGINE CONTROL INTERFACE SHI

870812-001

48KV 54MR 308-3 883AC-CAB B

REV	DATE	BY	APPROVED	REV	DATE	BY	APPROVED
1	12/18/83	W. ARNHILTER	[Signature]	1	12/18/83	W. ARNHILTER	[Signature]
2	1/15/84	W. ARNHILTER	[Signature]	2	1/15/84	W. ARNHILTER	[Signature]
3	2/15/84	W. ARNHILTER	[Signature]	3	2/15/84	W. ARNHILTER	[Signature]
4	3/15/84	W. ARNHILTER	[Signature]	4	3/15/84	W. ARNHILTER	[Signature]
5	4/15/84	W. ARNHILTER	[Signature]	5	4/15/84	W. ARNHILTER	[Signature]
6	5/15/84	W. ARNHILTER	[Signature]	6	5/15/84	W. ARNHILTER	[Signature]
7	6/15/84	W. ARNHILTER	[Signature]	7	6/15/84	W. ARNHILTER	[Signature]
8	7/15/84	W. ARNHILTER	[Signature]	8	7/15/84	W. ARNHILTER	[Signature]
9	8/15/84	W. ARNHILTER	[Signature]	9	8/15/84	W. ARNHILTER	[Signature]
10	9/15/84	W. ARNHILTER	[Signature]	10	9/15/84	W. ARNHILTER	[Signature]
11	10/15/84	W. ARNHILTER	[Signature]	11	10/15/84	W. ARNHILTER	[Signature]
12	11/15/84	W. ARNHILTER	[Signature]	12	11/15/84	W. ARNHILTER	[Signature]

ERBASCO SERVICES INCORPORATED
 BY: JAC
 IN REL
 TO: W. ARNHILTER
 DATE: 08/20/97

GEN. CONTROL PANEL (6852) POSITION: 9, 12, 5
 STOP: X, X, X, X, X, X, X, X
 LOCAL: X, X, X, X, X, X, X, X

ENGINE WIND

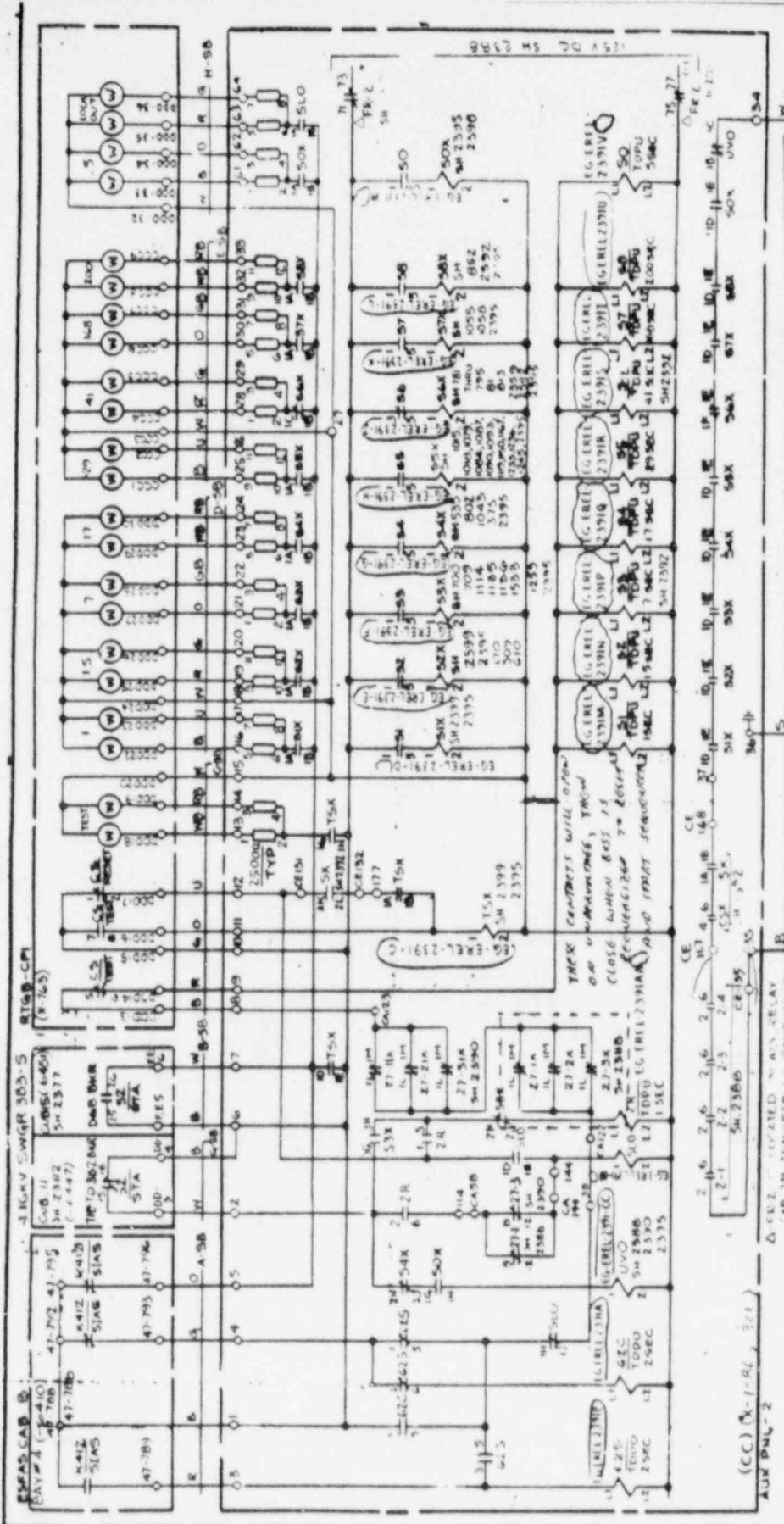

LOUISIANA POWER & LIGHT CO.
 WATERFORD S. S. UNIT No. 3
 CONTROL WIRING DIAGRAM
 SEQUENCER B SHEET

CONTROLLED COPY NO. 079
 SHEET #4
 (ANN. COPY)

SEQUENCER CHANGES BY LP&L

REV.	DATE	BY	APPROVED	DATE	BY	APPROVED
1	10/28/54	J. E. ...				
2	11/17/54	J. E. ...				
3	11/17/54	J. E. ...				
4	11/17/54	J. E. ...				
5	11/17/54	J. E. ...				
6	11/17/54	J. E. ...				
7	11/17/54	J. E. ...				
8	11/17/54	J. E. ...				
9	11/17/54	J. E. ...				
10	11/17/54	J. E. ...				
11	11/17/54	J. E. ...				
12	11/17/54	J. E. ...				
13	11/17/54	J. E. ...				
14	11/17/54	J. E. ...				
15	11/17/54	J. E. ...				
16	11/17/54	J. E. ...				
17	11/17/54	J. E. ...				
18	11/17/54	J. E. ...				
19	11/17/54	J. E. ...				
20	11/17/54	J. E. ...				
21	11/17/54	J. E. ...				
22	11/17/54	J. E. ...				
23	11/17/54	J. E. ...				
24	11/17/54	J. E. ...				
25	11/17/54	J. E. ...				
26	11/17/54	J. E. ...				
27	11/17/54	J. E. ...				
28	11/17/54	J. E. ...				
29	11/17/54	J. E. ...				
30	11/17/54	J. E. ...				
31	11/17/54	J. E. ...				
32	11/17/54	J. E. ...				
33	11/17/54	J. E. ...				
34	11/17/54	J. E. ...				
35	11/17/54	J. E. ...				
36	11/17/54	J. E. ...				
37	11/17/54	J. E. ...				
38	11/17/54	J. E. ...				
39	11/17/54	J. E. ...				
40	11/17/54	J. E. ...				
41	11/17/54	J. E. ...				
42	11/17/54	J. E. ...				
43	11/17/54	J. E. ...				
44	11/17/54	J. E. ...				
45	11/17/54	J. E. ...				
46	11/17/54	J. E. ...				
47	11/17/54	J. E. ...				
48	11/17/54	J. E. ...				
49	11/17/54	J. E. ...				
50	11/17/54	J. E. ...				
51	11/17/54	J. E. ...				
52	11/17/54	J. E. ...				
53	11/17/54	J. E. ...				
54	11/17/54	J. E. ...				
55	11/17/54	J. E. ...				
56	11/17/54	J. E. ...				
57	11/17/54	J. E. ...				
58	11/17/54	J. E. ...				
59	11/17/54	J. E. ...				
60	11/17/54	J. E. ...				
61	11/17/54	J. E. ...				
62	11/17/54	J. E. ...				
63	11/17/54	J. E. ...				
64	11/17/54	J. E. ...				
65	11/17/54	J. E. ...				
66	11/17/54	J. E. ...				
67	11/17/54	J. E. ...				
68	11/17/54	J. E. ...				
69	11/17/54	J. E. ...				
70	11/17/54	J. E. ...				
71	11/17/54	J. E. ...				
72	11/17/54	J. E. ...				
73	11/17/54	J. E. ...				
74	11/17/54	J. E. ...				
75	11/17/54	J. E. ...				
76	11/17/54	J. E. ...				
77	11/17/54	J. E. ...				
78	11/17/54	J. E. ...				
79	11/17/54	J. E. ...				
80	11/17/54	J. E. ...				
81	11/17/54	J. E. ...				
82	11/17/54	J. E. ...				
83	11/17/54	J. E. ...				
84	11/17/54	J. E. ...				
85	11/17/54	J. E. ...				
86	11/17/54	J. E. ...				
87	11/17/54	J. E. ...				
88	11/17/54	J. E. ...				
89	11/17/54	J. E. ...				
90	11/17/54	J. E. ...				
91	11/17/54	J. E. ...				
92	11/17/54	J. E. ...				
93	11/17/54	J. E. ...				
94	11/17/54	J. E. ...				
95	11/17/54	J. E. ...				
96	11/17/54	J. E. ...				
97	11/17/54	J. E. ...				
98	11/17/54	J. E. ...				
99	11/17/54	J. E. ...				
100	11/17/54	J. E. ...				

TYPE P.T.S. IN THIS SHEET
 SPRING RETURN TO NORMAL