

TABLE 3.7-3

ULTIMATE HEAT SINK MINIMUM FAN REQUIREMENTS PER TRAIN

AMBIENT CONDITION	<u>DRY COOLING TOWER</u>			
	<u>DRY BULB \geq 98°F</u>	<u>< 98°F DRY BULB \geq 91°F</u>	<u>< 91°F DRY BULB \geq 77°F</u>	<u>DRY BULB < 77°F</u>
Fan Requirements ⁽¹⁾	15	14*	12*	9*

AMBIENT CONDITION	<u>WET COOLING TOWER</u>		
	<u>WET BULB \geq 75°F</u>	<u>< 75°F WET BULB \geq 70°F</u>	<u>WET BULB < 70°F</u>
Fan Requirements ⁽¹⁾	8	7**	4**

(1) With any of the above required UHS fan inoperable comply with ACTION d.

* With a tornado watch in effect, all 9 DCT fans under the missile protected portion of the DCT shall be OPERABLE.

** With any WCT fan(s) out-of-service in any cell, covers must be in place on the out-of-service fan(s) or the entire cell (i.e. 4 fans) must be declared out-of-service. If four fans are out of service in the same cell, the covers do not have to be installed.

PLANT SYSTEMS
BASES

3/4.7.4 ULTIMATE HEAT SINK

The limitations on the ultimate heat sink level, temperature, and number of fans ensure that sufficient cooling capacity is available to either (1) provide normal cooldown of the facility, or (2) to mitigate the effects of accident conditions within acceptable limits.

The UHS consists of two dry cooling towers (DCTs), two wet cooling towers (WCTs), and water stored in WCT basins. Each of two 100 percent capacity loops employs a dry and wet cooling tower.

Each DCT consists of five separate cells. Cooling air for each cell is provided by 3 fans, for a total of 15 per DCT. The cooling coils on three cells of each DCT (i.e. 60%) are protected from tornado missiles by grating located above the coils and capable of withstanding tornado missile impact. With a Tornado Watch in effect and the number of fans OPERABLE within the missile protected area of a DCT less than that required by Table 3.7-3, ACTION c requires the restoration of inoperable fans within 1 hour or plant shutdown as specified. This ACTION is based on FSAR analysis (subsection 9.2.5.3.3) that assumes the worst case single failure as, 1 emergency diesel generator coincident with a loss of offsite power. This failure occurs subsequent to a tornado strike and 60% cooling capacity of a DCT is assumed available.

Each WCT has a basin which is capable of storing sufficient water to bring the plant to safe shutdown under all accident conditions. Item a of LCO 3/4.7.4 requires a minimum water level in each WCT basin of 97% (-9.86 ft MSL). The bases for this elevation is WCT water evaporation and drift loss calculations, which concluded that during a LOCA 168,738 gallons would be consumed from one WCT basin. When the WCT basin water level is maintained at -9.86 ft MSL, each basin has a minimum capacity of 174,000 gallons. Each WCT consists of two cells, each cell is serviced by 4 induced draft fans, for a total of 8 per WCT. There is a concrete partition between the cells that prevents air recirculation between the fans of each cell. Covers are required on fans declared out-of-service to prevent air recirculation between fans within a cell.

Table 3.7-3 specifies increased or decreased fan OPERABILITY requirements based on outside air temperature and humidity. The table provides the cooling tower fan OPERABILITY requirements that may vary with outside ambient conditions. Fan OPERABILITY requirements are specified for each controlling parameter (i.e., dry bulb temperatures for DCT fans and wet bulb temperatures for WCT fans). The calculated temperature values (EC-M95-009) associated with DCT and WCT fan requirements have been rounded in the conservative direction and lowered one full degree to account for minor inaccuracies. Failure to meet the OPERABILITY requirements of Table 3.7-3 requires entry into the applicable action. Because temperature and humidity are subject to change during the day, ACTION d requires periodic temperature readings to verify compliance with Table 3.7-3 when any cooling tower fan is inoperable.

The limitations on minimum water level and maximum temperature are based on providing a 30-day cooling water supply to safety-related equipment without exceeding their design basis temperature and is consistent with the recommendations of Regulatory Guide 1.27, "Ultimate Heat Sink for Nuclear Plants," March 1974.

NPF-38-197

ATTACHMENT B

TABLE 3.7-3

ULTIMATE HEAT SINK MINIMUM FAN REQUIREMENTS PER TRAIN

DRY COOLING TOWER

<u>AMBIENT CONDITION</u>	<u>DRY BULB \geq 98°F</u>	<u>< 98°F DRY BULB \geq 91°F</u>	<u>< 91°F DRY BULB</u>
Fan Requirements ⁽¹⁾	15	14*	12*

WET COOLING TOWER

<u>AMBIENT CONDITION</u>	<u>WET BULB \geq 75°F</u>	<u>< 75°F WET BULB \geq 70°F</u>	<u>WET BULB < 70°F</u>
Fan Requirements ⁽¹⁾	8	7**	4**

(1) With any of the above required UHS fan inoperable comply with ACTION d.

* With a tornado watch in effect, all 9 DCT fans under the missile protected portion of the DCT shall be OPERABLE.

** With any WCT fan(s) out-of-service in any cell, covers must be in place on the out-of-service fan(s) or the entire cell (i.e. 4 fans) must be declared out-of-service. If four fans are out of service in the same cell, the covers do not have to be installed.

PLANT SYSTEMS
BASES

3/4.7.4 ULTIMATE HEAT SINK

The limitations on the ultimate heat sink level, temperature, and number of fans ensure that sufficient cooling capacity is available to either (1) provide normal cooldown of the facility, or (2) to mitigate the effects of accident conditions within acceptable limits.

The UHS consists of two dry cooling towers (DCTs), two wet cooling towers (WCTs), and water stored in WCT basins. Each of two 100 percent capacity loops employs a dry and wet cooling tower.

Each DCT consists of five separate cells. Cooling air for each cell is provided by 3 fans, for a total of 15 per DCT. The cooling coils on three cells of each DCT (i.e. 60%) are protected from tornado missiles by grating located above the coils and capable of withstanding tornado missile impact. With a Tornado Watch in effect and the number of fans OPERABLE within the missile protected area of a DCT less than that required by Table 3.7-3, ACTION c requires the restoration of inoperable fans within 1 hour or plant shutdown as specified. This ACTION is based on FSAR analysis (subsection 9.2.5.3.3) that assumes the worst case single failure as, 1 emergency diesel generator coincident with a loss of offsite power. This failure occurs subsequent to a tornado strike and 60% cooling capacity of a DCT is assumed available.

Each WCT has a basin which is capable of storing sufficient water to bring the plant to safe shutdown under all design basis accident conditions. Item a of LCO 3/4.7.4 requires a minimum water level in each WCT basin of 97% (-9.86 ft. MSL). The bases for this elevation is WCT water evaporation and drift loss calculations, which concluded that during a LOCA 164,389 gallons (218,155 gallons with the non-essential load of spent fuel cooling) would be consumed from one WCT basin. When the WCT basin water level is maintained at -9.86 ft. MSL, each basin has a minimum capacity of 174,000 gallons. Each WCT consists of two cells, each cell is serviced by 4 induced draft fans, for a total of 8 per WCT. There is a concrete partition between the cells that prevents air re-circulation between the fans of each cell. Covers are required on fans declared out-of-service to prevent air re-circulation between fans within a cell.

Table 3.7-3 specifies increased or decreased fan OPERABILITY requirements based on outside air temperature and humidity. The table provides the cooling tower fan OPERABILITY requirements that may vary with outside ambient conditions. Fan OPERABILITY requirements are specified for each controlling parameter (i.e., dry bulb temperatures for DCT fans and wet bulb temperatures for WCT fans). The calculated temperature values (EC-M95-009) associated with DCT and WCT fan requirements have been rounded in the conservative direction and lowered at least one full degree to account for minor inaccuracies. Failure to meet the OPERABILITY requirements of Table 3.7-3 requires entry into the applicable action. Because temperature and humidity are subject to change during the day, ACTION d requires periodic temperature readings to verify compliance with Table 3.7-3 when any cooling tower fan is inoperable.

The limitations on minimum water level and maximum temperature are based on providing a 30-day cooling water supply to safety-related equipment without exceeding their design basis temperature and is consistent with the recommendations of Regulatory Guide 1.27, "Ultimate Heat Sink for Nuclear Plants," March 1974.

NPF-38-197

FIGURE 1

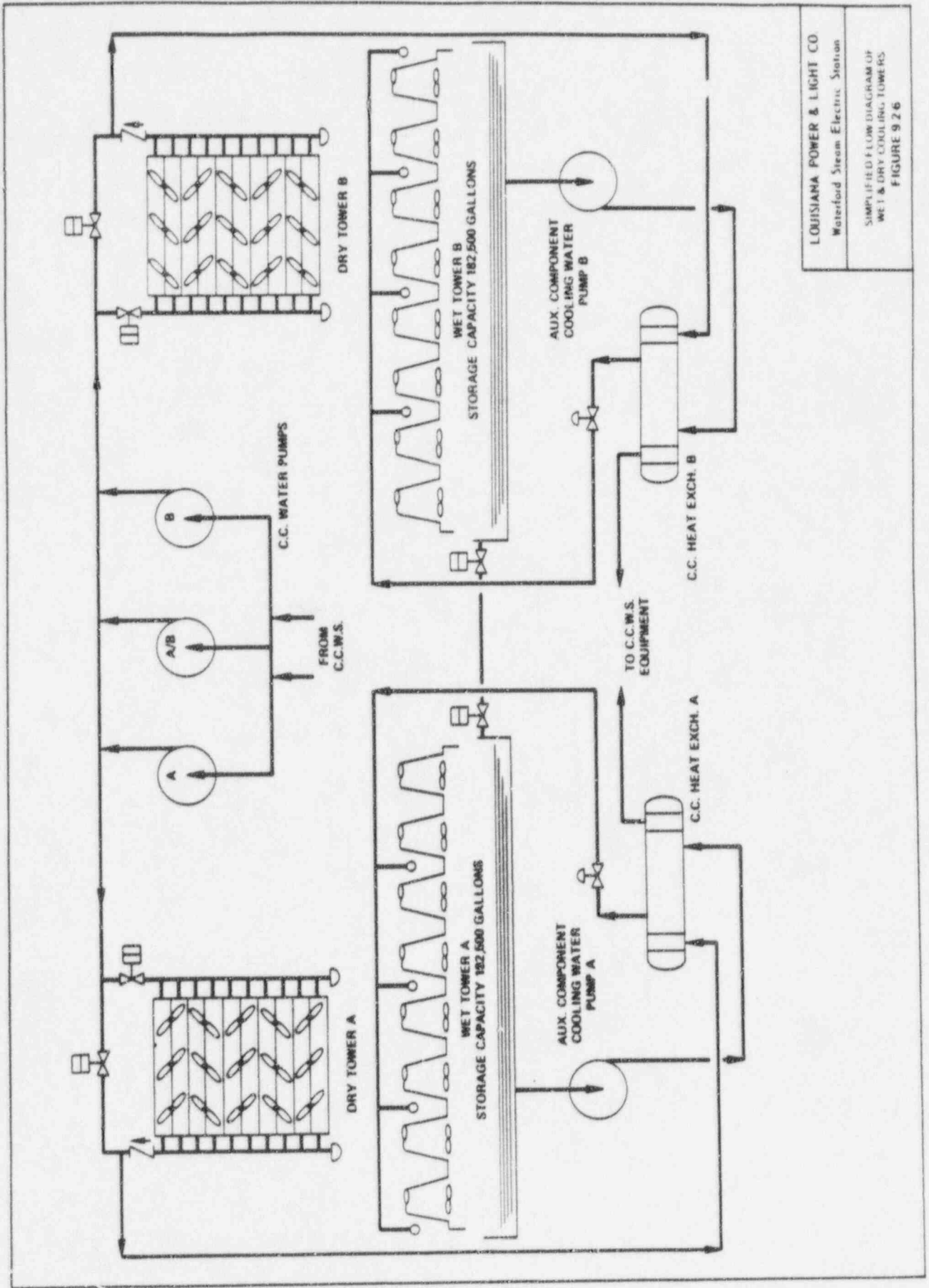

LOUISIANA POWER & LIGHT CO
 Waterford Steam Electric Station
 SIMPLIFIED FLOW DIAGRAM OF
 WET & DRY COOLING TOWERS
 FIGURE 9 2 6