

NUREG-0750  
Vol. 23, No. 1  
Pages 1-47

# NUCLEAR REGULATORY COMMISSION ISSUANCES

January 1986



**U.S. NUCLEAR REGULATORY COMMISSION**

B604030276 B60331  
PDR NUREG  
0750 R PDR

Available from

Superintendent of Documents  
U.S. Government Printing Office  
Post Office Box 37082  
Washington, D.C. 20013-7082

A year's subscription consists of 12 softbound issues,  
4 indexes, and 4 hardbound editions for this publication.

Single copies of this publication  
are available from National Technical  
Information Service, Springfield, VA 22161

Errors in this publication may be reported to the Division of  
Technical Information and Document Control, Office of Administration,  
U.S. Nuclear Regulatory Commission, Washington, D.C. 20555  
(301/492-8925) or (301/492-7566)

NUREG-0750  
Vol. 23, No. 1  
Pages 1-47

# NUCLEAR REGULATORY COMMISSION ISSUANCES

January 1986

This report includes the issuances received during the specified period from the Commission (CLI), the Atomic Safety and Licensing Appeal Boards (ALAB), the Atomic Safety and Licensing Boards (LBP), the Administrative Law Judge (ALJ), the Directors' Decisions (DD), and the Denials of Petitions for Rulemaking (DPRM).

The summaries and headnotes preceding the opinions reported herein are not to be deemed a part of those opinions or to have any independent legal significance.

**U.S. NUCLEAR REGULATORY COMMISSION**

Prepared by the Division of Technical Information and Document Control,  
Office of Administration, U.S. Nuclear Regulatory Commission, Washington, D.C. 20555  
(301/492-8925)

## COMMISSIONERS

Nunzio J. Palladino, Chairman  
Thomas M. Roberts  
James K. Asselstine  
Frederick M. Bernthal  
Lando W. Zech, Jr.

---

Alan S. Rosenthal, Chairman, Atomic Safety and Licensing Appeal Panel  
B. Paul Cotter, Chairman, Atomic Safety and Licensing Board Panel

## CONTENTS

### Issuance of the Nuclear Regulatory Commission

LOUISIANA POWER & LIGHT COMPANY (Waterford Steam Electric Station, Unit 3) Docket 50-382-OL MEMORANDUM AND ORDER, CLI-86-1, January 30, 1986 . . .	1
---	---

### Issuances of the Atomic Safety and Licensing Appeal Boards

LONG ISLAND LIGHTING COMPANY (Shoreham Nuclear Power Station, Unit 1) Docket 50-322-OL-3 (Emergency Planning) MEMORANDUM AND ORDER, ALAB-827, January 9, 1986 . . . . .	9
---	---

PHILADELPHIA ELECTRIC COMPANY (Limerick Generating Station, Units 1 and 2) Dockets 50-352-OL, 50-353-OL MEMORANDUM AND ORDER, ALAB-828, January 16, 1986 . . . . .	13
--	----

### Issuances of the Atomic Safety and Licensing Boards

PACIFIC GAS AND ELECTRIC COMPANY (Humboldt Bay Power Plant, Unit 3) Docket 50-133-OLA (ASLBP No. 77-357-07-LA) (Amendment to Facility Operating License) MEMORANDUM AND ORDER TERMINATING PROCEEDING, LBP-86-1, January 14, 1986 . . . . .	25
---	----

PRECISION MATERIALS CORPORATION (Mine Hill, New Jersey Irradiator Facility) Docket 30-22063 (ASLBP No. 85-512-02-ML) MEMORANDUM AND ORDER, LBP-86-2, January 28, 1986 . . . . .	28
---	----

**Issuance of the Administrative Law Judge**

**KENNETH L. BURTON**

Docket 55-60575 (ASLBP No. 86-515-01-SP) (Senior Operator  
License for Millstone Nuclear Power Station, Unit 3)

**ORDER TERMINATING PROCEEDING,**

ALJ-86-1, January 27, 1986 ..... 31

**Issuances of Directors' Decisions**

**ARKANSAS POWER AND LIGHT COMPANY**

(Arkansas Nuclear One, Unit 1)

Docket 50-313

**DIRECTOR'S DECISION UNDER 10 C.F.R. § 2.206,**

DD-85-19, January 29, 1986 ..... 33

**DUKE POWER COMPANY, et al.**

(Oconee Nuclear Station, Units 1, 2, and 3)

Dockets 50-269, 50-270, 50-287

**DIRECTOR'S DECISION UNDER 10 C.F.R. § 2.206,**

DD-85-19, January 29, 1986 ..... 33

**FLORIDA POWER CORPORATION**

(Crystal River Unit No. 3 Nuclear Generating Plant)

Docket 50-302

**DIRECTOR'S DECISION UNDER 10 C.F.R. § 2.206,**

DD-85-19, January 29, 1986 ..... 33

**GENERAL PUBLIC UTILITIES NUCLEAR CORPORATION**

(Three Mile Island Nuclear Station, Unit 1)

Docket 50-289

**DIRECTOR'S DECISION UNDER 10 C.F.R. § 2.206,**

DD-85-19, January 29, 1986 ..... 33

**PHILADELPHIA ELECTRIC COMPANY**

(Limerick Generating Station, Unit 1)

Docket 50-352

**DIRECTOR'S DECISION UNDER 10 C.F.R. § 2.206,**

DD-86-1, January 21, 1986 ..... 39

SACRAMENTO MUNICIPAL UTILITY DISTRICT  
(Rancho Seco Nuclear Generating Station)

Docket 50-312

DIRECTOR'S DECISION UNDER 10 C.F.R. § 2.206,

DD-85-19, January 29, 1986 ..... 33

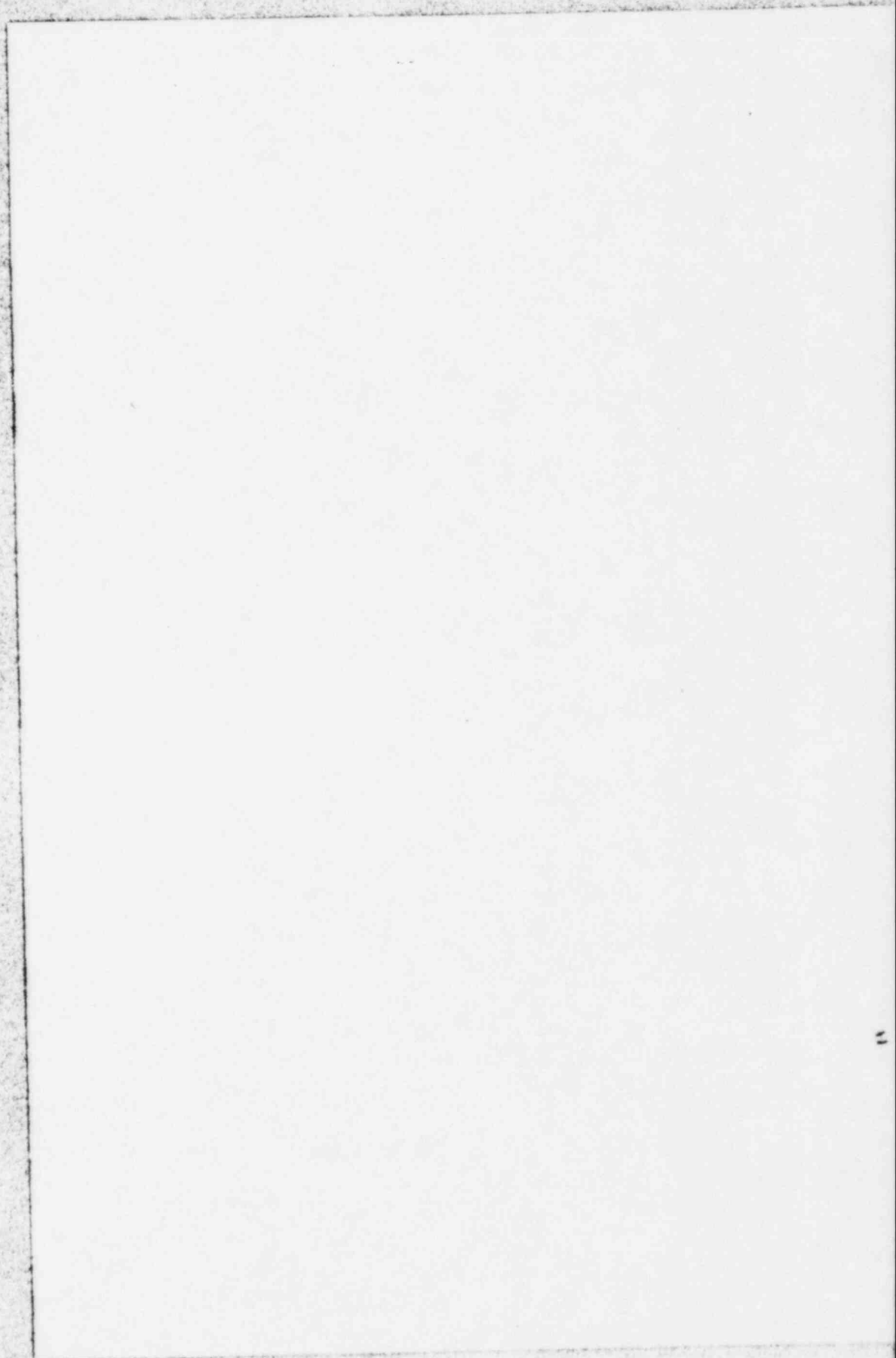



**Commission  
Issuances**

**COMMISSION**

UNITED STATES OF AMERICA  
NUCLEAR REGULATORY COMMISSION

**COMMISSIONERS:**

**Nunzio J. Palladino, Chairman**  
**Thomas M. Roberts**  
**James K. Asselstine**  
**Frederick M. Bernthal**  
**Lando W. Zech, Jr.**

In the Matter of

Docket No. 50-382-OL

**LOUISIANA POWER & LIGHT  
COMPANY**  
**(Waterford Steam Electric  
Station, Unit 3)**

January 30, 1986

The Commission denies the remaining aspect of Joint Intervenors' motion to reopen the record in this operating license proceeding on management character and competence. The Commission finds that Joint Intervenors' motion to reopen, which is based on the pendency of ongoing investigations of the Office of Investigations, does not meet the heavy burden required to reopen a closed record.

**RULES OF PRACTICE: REOPENING OF RECORD**

The standards for reopening a closed record require consideration of three factors: (1) whether the motion to reopen is timely; (2) whether the information raises a significant safety (or environmental) concern; and (3) whether the information might have led the Licensing Board to reach a different result. *See, e.g., Metropolitan Edison Co. (Three Mile Island Nuclear Station, Unit 1), CLI-85-2, 21 NRC 282, 311 (1985).*

### **RULES OF PRACTICE: REOPENING OF RECORD**

The burden of satisfying the reopening requirements is a heavy one. *See, e.g., Kansas Gas and Electric Co.* (Wolf Creek Generating Station, Unit 1), ALAB-462, 7 NRC 320, 338 (1978); *Duke Power Co.* (Catawba Nuclear Station, Units 1 and 2), ALAB-359, 4 NRC 619, 620-21 (1976). Bare allegations or the simple submission of new contentions are not enough to meet these standards. *Pacific Gas and Electric Co.* (Diablo Canyon Nuclear Power Plant, Units 1 and 2), CLI-81-5, 13 NRC 361, 363 (1981).

### **RULES OF PRACTICE: REOPENING OF RECORD (SPECIFICITY)**

At a minimum, the new material in support of a motion to reopen must be set forth with a degree of particularity in excess of the basis and specificity requirements contained in 10 C.F.R. § 2.714(b) for admissible contentions. It must be tantamount to evidence and possess the attributes set forth in 10 C.F.R. § 2.743(c) defining admissible evidence for adjudicatory proceedings. Specifically, the new evidence supporting the motion must be relevant, material and reliable. *Pacific Gas and Electric Co.* (Diablo Canyon Nuclear Power Plant, Units 1 and 2), ALAB-775, 19 NRC 1361, 1366-67, *aff'd sub nom. San Luis Obispo Mothers for Peace v. NRC*, 751 F.2d 1287 (D.C. Cir. 1984), *vacated in part and reh'g en banc granted on other grounds*, 760 F.2d 1320 (1985). Information that investigations are under way by itself does not meet this standard.

### **RULES OF PRACTICE: REOPENING OF RECORD**

A movant in seeking to meet the heavy burden required to justify reopening a closed record is not entitled to engage in discovery in order to support the motion. Rather, the issue in each case is whether the available information meets the standards for reopening. *Metropolitan Edison Co.* (Three Mile Island Nuclear Station, Unit 1), CLI-85-7, 21 NRC 1104, 1106 (1985). It is not the duty of the adjudicatory boards to search for evidence that might fill in gaps in the moving party's submissions.

### **RULES OF PRACTICE: RESPONSIBILITY OF PARTIES**

The Commission's Policy Statement on Investigations, Inspections, and Adjudicatory Proceedings, 49 Fed. Reg. 36,032 (Sept. 13, 1984), ad-

dresses the conflict between the duty to disclose investigation or inspection information to the boards and parties and the need to protect that information. The provisions of that Policy Statement come into play only when Staff or OI have new information material and relevant to any "issue in controversy in the proceeding." Previously uncontested issues raised in a motion to reopen are not "issues in controversy in a proceeding" unless and until both the motion to reopen is granted and the contention is admitted.

#### **OPERATING LICENSE HEARINGS: *SUA SPONTE* ISSUES**

Boards have the authority to examine issues not placed in controversy by the parties only where specific facts are brought to their attention indicating that there is a serious safety, environmental, or common defense and security matter. See 10 C.F.R. § 2.760a; *Texas Utilities Generating Co.* (Comanche Peak Steam Electric Station, Units 1 and 2), CLI-81-24, 14 NRC 614, 615 (1981). The mere pendency of OI investigations by themselves does not raise a serious safety matter.

### **MEMORANDUM AND ORDER**

On July 11, 1985, the Appeal Board issued ALAB-812, which denied the fifth and final motion to reopen filed in this proceeding "in all respects save one: insofar as the motion raises issues that may relate to matters under investigation by OI, we [the Appeal Board] are unable to rule and therefore leave that part of the motion for the Commission's resolution." 22 NRC 5, 13 (1985) (footnote omitted). As explained below, the Commission has decided to deny the remaining portion of the motion to reopen.<sup>1</sup>

#### **I.**

Joint Intervenors on November 8, 1984, moved the Appeal Board to reopen the record of this proceeding on three new contentions. The Appeal Board denied the motion to reopen on two of the proposed contentions. The third proposed contention sought reopening on the charac-

---

<sup>1</sup> Joint Intervenors have requested the Commission to review ALAB-812. Neither of the issues raised by Joint Intervenors meets the standard set forth in 10 C.F.R. § 2.786(b)(4) for Commission review. Joint Intervenors' request is therefore denied.

ter and competence of Louisiana Power & Light Company (LP&L). As summarized by the Appeal Board, Joint Intervenors charged that LP&L's lack of character and competence was demonstrated in essentially six ways. The Appeal Board concluded that five of the six charges did not, either individually or collectively, raise a significant safety issue. On the sixth charge — that pending investigations by the NRC's Office of Investigations (OI) into allegations of falsification of records and harassment of quality assurance/quality control (QA/QC) personnel at the site demonstrate a lack of character and competence — the Appeal Board found that the state of the record did not permit a judgment one way or the other. 22 NRC at 45.

The Appeal Board, "[b]ecause of the dearth of publicly available information concerning OI's investigations, . . . [had] solicited more details directly from OI." *Id.* at 46. The Appeal Board stated that it was unable to obtain "complete, usable information" from OI, and therefore that it "took the unusual step of reviewing some of the investigative documents [itself], in the NRC Regional Office where they are located." *Id.* at 46-47. The Appeal Board, noting that nothing it had seen had given it "cause for significant concern about the integrity of LP&L's management," also stated that it could not "rule out all possible grounds for Joint Intervenors' charges." *Id.* at 47.

In view of OI's opposition to release of information to the parties, the Appeal Board found that it had no expectation of getting adequate information from OI which it could share with the parties within a reasonable period of time. Since it could not rely on information not available to the parties, the Appeal Board found that "neither a denial nor a grant of the motion to reopen would be sustainable or fair." *Id.* The Appeal Board, concluding that only the Commission could obtain full access to information developed by OI, left the matter for the Commission to resolve.

## II.

The Appeal Board's actions in seeking information from OI and then referring one portion of the motion to reopen to the Commission present two issues for the Commission to resolve: (1) Does the remaining portion of Joint Intervenors' motion to reopen meet the Commission's standards for reopening; and (2) did the Appeal Board have the authority to seek additional information from OI before ruling on the motion to reopen? We will address each issue in turn.

The standards for reopening a closed record require consideration of three factors: (1) whether the motion to reopen is timely; (2) whether

the information raises a significant safety (or environmental) concern; and (3) whether the information might have led the Licensing Board to reach a different result. See, e.g., *Metropolitan Edison Co.* (Three Mile Island Nuclear Station, Unit 1), CLI-85-2, 21 NRC 282, 311 (1985). The burden of satisfying the reopening requirements is a heavy one. See, e.g., *Kansas Gas and Electric Co.* (Wolf Creek Generating Station, Unit 1), ALAB-462, 7 NRC 320, 338 (1978); *Duke Power Co.* (Catawba Nuclear Station, Units 1 and 2), ALAB-359, 4 NRC 619, 620-21 (1976). "[B]are allegations or simple submission of new contentions" are not enough to meet these standards. *Pacific Gas and Electric Co.* (Diablo Canyon Nuclear Power Plant, Units 1 and 2), CLI-81-5, 13 NRC 361, 363 (1981).

At a minimum . . . the new material in support of a motion to reopen must be set forth with a degree of particularity in excess of the basis and specificity requirements contained in 10 C.F.R. 2.714(b) for admissible contentions. Such supporting information must be more than mere allegations; it must be tantamount to evidence . . . [and] possess the attributes set forth in 10 C.F.R. 2.743(c) defining admissible evidence for adjudicatory proceedings. Specifically, the new evidence supporting the motion must be "relevant, material, and reliable."

*Pacific Gas and Electric Co.* (Diablo Canyon Nuclear Power Plant, Units 1 and 2), ALAB-775, 19 NRC 1361, 1366-67, *aff'd sub nom. San Luis Obispo Mothers for Peace v. NRC*, 751 F.2d 1287 (D.C. Cir. 1984), *vacated in part and reh'g en banc granted on other grounds*, 760 F.2d 1320 (1985) (footnote omitted).

The only aspect of Joint Intervenors' motion to reopen left before the Commission is the assertion that the existence of OI investigations into allegations of falsification of records and harassment of QA/QC personnel demonstrates a fundamental lack of character and competence in LP&L. The Commission finds that Joint Intervenors' motion to reopen, which is based on the pendency of ongoing OI investigations, does not meet the heavy burden required to reopen a closed record.

OI conducts investigations of licensees and licensees' contractors to determine whether there has been a violation of NRC requirements involving wrongdoing. The bare pendency of an investigation does not indicate that there is a substantive problem, or even that there has been a violation. Nor does it indicate that an allegation raises a significant safety issue. The pendency of an OI investigation indicates only that there is an allegation that is being investigated. The material proffered by Joint Intervenors, i.e., that investigations are under way, certainly is not "tantamount to evidence," and is not the type of "relevant, material, and relia-

ble" new information required to reopen a record.<sup>2</sup> See *Diablo Canyon, supra*, ALAB-775, 19 NRC at 1366-67.

Since Joint Intervenors' motion to reopen by itself does not meet the Commission's standards for reopening,<sup>3</sup> the Commission must address whether the Appeal Board had the authority to look at information developed by OI before ruling on the motion.

A movant in seeking to meet the heavy burden required to justify reopening a closed record "is not entitled to engage in discovery in order to support [the] motion . . . . Rather, the issue in each case is whether the available information meets the standards for reopening . . . ." *Metropolitan Edison Co.* (Three Mile Island Nuclear Station, Unit 1), CLI-85-7, 21 NRC 1104, 1106 (1985). It is not the duty of the adjudicatory boards to search for evidence that might fill in gaps in the moving party's submissions. Accordingly, in this sense it is not necessary, as the Appeal Board's decision may suggest, to "rule out all possible grounds for Joint Intervenors' charges." ALAB-812, *supra*, 22 NRC at 47.

Here, rather than a party seeking to engage in discovery, the Appeal Board itself in effect sought discovery. Given what we have said about the movant's burden to support a reopening motion, there are two possible sources of authority for the Appeal Board's actions: (1) the Commission's Policy Statement on Investigations, Inspections, and Adjudicatory Proceedings, 49 Fed. Reg. 36,032 (Sept. 13, 1984); and (2) the

---

<sup>2</sup> Joint Intervenors in their motion to reopen refer to a transcript of a meeting between Staff and OI personnel and officers of LP&L and to an article from the *Wall Street Journal*. The transcript of the meeting does not contain probative information regarding OI's investigations. The claim based on the *Wall Street Journal* that OI is ready to refer "over four cases" to the Department of Justice indicates nothing about how those cases bear on the current management and operation of Waterford. The Appeal Board noted that it is also incorrect. See ALAB-812, *supra*, 22 NRC at 47 n.52. Moreover, hearsay based on a newspaper article does not constitute the kind of evidence that can support a reopening motion.

The Appeal Board also grouped one other Joint Intervenors' charge — that LP&L took retaliatory action against QA personnel who adhered strictly to QA procedures — with the charges based on OI's investigations. *Id.* at 45 n.49. The affidavit Joint Intervenors cite to support this charge primarily addresses alleged QA deficiencies. The Appeal Board denied that portion of Joint Intervenors' motion to reopen which dealt with alleged QA deficiencies. The remaining portion of the affidavit, dealing with the alleged termination, is not sufficient by itself to raise a significant safety concern which might have led the Licensing Board to reach a different conclusion.

The Commission also notes in this regard that the Appeal Board, even after reviewing information developed by OI, stated "[n]othing we have seen gives us cause for significant concern about the integrity of LP&L's management." *Id.* at 47. If there was no cause for concern, even after reviewing OI information, then *a fortiori* it follows that the standards for reopening were not met.

<sup>3</sup> In addition, Joint Intervenors' motion to reopen raises previously uncontested issues, and therefore must also satisfy the Commission's standards for admitting late-filed contentions, which are contained in 10 C.F.R. § 2.714(a)(1). See generally, e.g., *Pacific Gas and Electric Co.* (Diablo Canyon Nuclear Power Plant, Units 1 and 2), CLI-82-39, 16 NRC 1712, 1714-15 (1982). Since the Commission finds that the remaining portion of Joint Intervenors' motion does not meet the standards for reopening, it need not address whether the motion meets the standards for late-filed contentions.

Board's authority *sua sponte* to pursue uncontested issues. We will discuss each in turn.

The Commission's Policy Statement on Investigations, Inspections, and Adjudicatory Proceedings addresses the conflict between the duty to disclose investigation or inspection information to the boards and parties and the need to protect that information. The Commission in that Policy Statement provides in certain circumstances for *ex parte in camera* presentations by OI or the NRC Staff "[w]hen staff or OI believes that it has a duty in a particular case to provide an adjudicatory board with information concerning an inspector or investigation, or when a board requests such information. . . ." *Id.* at 36,033. However, these provisions come into play only when Staff or OI have new information "which is considered material and relevant to any *issue in controversy in the proceeding.*" *Id.* at 36,032 (emphasis added). Previously uncontested issues raised in a motion to reopen are not "issues in controversy in a proceeding" such that the Policy Statement would come into play unless and until both the motion to reopen is granted and the contention is admitted.<sup>4</sup>

Nor did the Appeal Board here have the authority *sua sponte* to seek to obtain information relevant to the motion to reopen. Boards have the authority to examine issues not placed in controversy by the parties only where specific facts are brought to their attention indicating that there is a serious safety, environmental, or common defense and security matter. See 10 C.F.R. § 2.760a; *Texas Utilities Generating Co.* (Comanche Peak Steam Electric Station, Units 1 and 2), CLI-81-24, 14 NRC 614, 615 (1981). The Appeal Board made no such finding here, and none could have been made because, as explained above, the mere pendency of OI investigations by themselves here — the basic specific fact brought to the Appeal Board's attention — does not raise a serious safety matter. Accordingly, the Board had no authority to pursue this matter as it did.<sup>5</sup>

---

<sup>4</sup> Accordingly, since the motion to reopen in this case involved a previously uncontested issue, the Staff had no "duty" to inform the Appeal Board that OI had information "material and relevant" to the motion to reopen, and the fact that the Staff advised the Appeal Board that OI had information "related to" the motion to reopen did not give the Appeal Board the authority under the Policy Statement to request OI to produce that information.

<sup>5</sup> At an operating license hearing, a board passes only on issues put in contest. The decision as to all other matters which need to be addressed prior to issuance of the license is the responsibility of the Commission and Staff outside of the adjudicatory context.

The Commission will, of course, outside of this proceeding take whatever action is appropriate once OI completes its investigations, and, if OI develops information impacting on the public health and safety during its investigation, the Commission will take appropriate action at that time.



### III.

In conclusion, that portion of Joint Intervenors' motion to reopen which the Appeal Board referred to the Commission fails on its face to meet the standards for reopening a closed record. In addition, the Appeal Board here did not have the authority to seek additional information from OI bearing on the motion to reopen. Accordingly, the remaining portion of the motion to reopen is denied.<sup>6</sup>

Chairman Palladino and Commissioner Asselstine disapproved this Order. The dissenting views of Chairman Palladino, with which Commissioner Asselstine agrees, are attached.

It is so ORDERED.

For the Commission

SAMUEL J. CHILK  
Secretary of the Commission

Dated at Washington, D.C.,  
this 30th day of January 1986.

### DISSENTING VIEWS OF CHAIRMAN PALLADINO

I would have preferred that the Commission postpone ruling on the motion to reopen and request clarification from the Appeal Board in order to determine exactly what type of information the Board wished to obtain from OI. Upon reply from the Board, the Commission then could have determined whether or not to remand the motion to the Appeal Board, with appropriate instructions, or take some other action. In addition, I do not agree with the statement in the Order that the NRC Staff had no duty to inform the Appeal Board of the OI information. I believe that statement is not consistent with the Board Notification policy as implemented by the NRC Staff.

---

<sup>6</sup> The Commission, in view of its decision that the standards for reopening are not met, need not address whether the Appeal Board had jurisdiction over this remaining aspect of the motion to reopen.

# Atomic Safety and Licensing Appeal Boards Issuances

ATOMIC SAFETY AND LICENSING APPEAL PANEL

Alan S. Rosenthal, Chairman  
Dr. W. Reed Johnson  
Thomas S. Moore  
Christine N. Kohl  
Gary J. Edles  
Dr. Reginald L. Gotchy  
Howard A. Wilber

APPEAL BOARDS

UNITED STATES OF AMERICA  
NUCLEAR REGULATORY COMMISSION

**ATOMIC SAFETY AND LICENSING APPEAL BOARD**

**Administrative Judges:**

**Alan S. Rosenthal, Chairman**  
**Gary J. Edles**  
**Howard A. Wilber**

**In the Matter of**

**Docket No. 50-322-OL-3**  
**(Emergency Planning)**

**LONG ISLAND LIGHTING**  
**COMPANY**  
**(Shoreham Nuclear Power**  
**Station, Unit 1)**

**January 9, 1986**

The Appeal Board denies the intervenors' request for leave to file a 20-page brief in addition to the 100-page joint brief already filed by them.

**RULES OF PRACTICE: BRIEFS**

The Commission's regulations impose a 70-page limit on appellate briefs. A motion requesting an increase in this page limit for good cause may be made, but such a motion must be submitted at least seven days in advance of the due date for filing the brief. 10 C.F.R. § 2.762(e).

**RULES OF PRACTICE: APPELLATE REVIEW**

Not every error of a hearing board justifies an appellate remedy.

### **RULES OF PRACTICE: APPELLATE REVIEW**

Appellate review is not intended to offer losing parties a forum for simply renewing claims presented to, but rejected by, the trial tribunal.

### **RULES OF PRACTICE: APPELLATE REVIEW**

Proceedings on appeal are intended to focus on significant matters, not every colorable claim of error. *See generally Jones v. Barnes*, 463 U.S. 745, 752-53 (1983) (the purpose of an appellate presentation is to select the most promising issues for review). *See also id.* at 761 (Brennan and Marshall, JJ., dissenting) (good appellate advocacy demands selectivity among arguments).

### **MEMORANDUM AND ORDER**

The Commission's regulations impose a 70-page limit on appellate briefs.<sup>1</sup> Intervenors Suffolk County and the State of New York sought leave to file a 165-page consolidated brief in support of their appeals from one of the Licensing Board's partial initial decisions in the emergency planning phase of this operating license proceeding.<sup>2</sup> In an unpublished May 15, 1985 order, we authorized the County and State to file either a consolidated brief not to exceed 100 pages or separate 70-page briefs in accordance with the regulations. Thereafter, the parties moved for reconsideration of our May 15 order; specifically, they sought leave to file separate briefs not to exceed 100 pages each. We denied that request in an unpublished October 3, 1985 order.

The County and the State, together with the intervenor Town of Southampton, have filed a 100-page consolidated brief. In a footnote contained in the brief, the intervenors now request leave to file another 20-page brief to address additional issues. We deny the request.

We see no justification for any further enlargement of the page limit. In accordance with our earlier orders, the two intervening parties had the option of filing separate briefs (with an aggregate total of 140 pages) or a consolidated brief not to exceed 100 pages. They selected the latter

<sup>1</sup> 10 C.F.R. § 2.762(e).

<sup>2</sup> *See* LBP-85-12, 21 NRC 644 (1985).

option and we see no reason why they should not be bound by their election.<sup>3</sup>

The intervenors aver that, despite their efforts to produce a concise product, the additional issues could not be covered within the 100-page limit.<sup>4</sup> They argue, in this connection, that "no significant error" in the Licensing Board's decision should escape appellate review. But, contrary to intervenors' apparent belief, not every error justifies an appellate remedy. Our experience, both generally and with respect to earlier appeals in this very case, satisfies us that every assertion of error does not translate into grounds for reversal of Licensing Board determinations.<sup>5</sup> Equally important, the number of pages contained in the appellate briefs does not bear any necessary relationship to the substance of the issues raised.

Appellate review is not intended to offer losing parties a forum for simply renewing claims presented to, but rejected by, the trial tribunal. To be sure, NRC licensing proceedings ordinarily involve lengthy evidentiary records and present numerous complicated and detailed technical issues for resolution. In recognition of that fact, the Commission, in contrast with many federal agencies, has provided two levels of appellate review, and appeal boards frequently examine in some depth a wide range of technical and legal matters. But that does not alter the fundamental purpose of appellate review. Proceedings on appeal are intended to focus on significant matters, not every colorable claim of error.<sup>6</sup> We expect advocates to cull the issues and arguments to be pursued on appeal.

---

<sup>3</sup> We note, in addition, that the most recent request for additional pages was not filed seven days in advance of the due date for filing the brief as required by 10 C.F.R. § 2.762(e). The request could be summarily denied on that ground. Moreover, the "motion" is contained in a footnote. There is no indication on the face of the brief, in the Table of Contents, or, indeed, in the Conclusion section that sets out the prayer for relief, that the intervenors seek any enlargement of the page limit. We expect an affirmative request for relief, such as an application for enlargement of the page limit, to be set out prominently. *Cf. Duke Power Co. (Cherokee Nuclear Station, Units 1, 2, and 3)*, ALAB-457, 7 NRC 70 (1978).

<sup>4</sup> Those issues include the evacuation of the transit-dependent population and the identification and notification of the handicapped and the deaf. Suffolk County, State of New York, and Town of Southampton Brief on Appeal of Licensing Board April 17, 1985 Partial Initial Decision on Emergency Planning (Oct. 23, 1985) at 1 n.1. The intervenors nonetheless appear to have referred to these issues, at least in part, elsewhere in the brief. *Id.* at 79.

<sup>5</sup> See, e.g., ALAB-788, 20 NRC 1102, 1151 (1984).

<sup>6</sup> See generally *Jones v. Barnes*, 463 U.S. 745, 752-53 (1983) (the purpose of an appellate presentation is to select the most promising issues for review). See also *id.* at 761 (Brennan and Marshall, JJ., dissenting) (good appellate advocacy demands selectivity among arguments).

Intervenors' request for further enlargement of the page limitation is *denied*.

It is so ORDERED.

FOR THE APPEAL BOARD

C. Jean Shoemaker  
Secretary to the  
Appeal Board

UNITED STATES OF AMERICA  
NUCLEAR REGULATORY COMMISSION

**ATOMIC SAFETY AND LICENSING APPEAL BOARD**

**Administrative Judges:**

Christine N. Kohl, Chairman  
Gary J. Edles  
Dr. Reginald L. Gotchy

In the Matter of

Docket Nos. 50-352-OL  
50-353-OL

**PHILADELPHIA ELECTRIC COMPANY**  
(Limerick Generating Station,  
Units 1 and 2)

January 16, 1986

The Appeal Board affirms the Licensing Board's denial of intervenors' request to reopen the record in this operating license proceeding.

**RULES OF PRACTICE: REOPENING OF PROCEEDINGS**

In ruling on a motion to reopen the record, adjudicatory boards consider three factors: (1) whether the motion is timely; (2) whether it addresses a significant safety or environmental issue; and (3) whether a different result might have been reached had the newly proffered material been considered initially. *Metropolitan Edison Co.* (Three Mile Island Nuclear Station, Unit 1), CLI-85-2, 21 NRC 282, 285 n.3, *reconsideration denied*, CLI-85-7, 21 NRC 1104 (1985).

**RULES OF PRACTICE: REOPENING OF PROCEEDINGS**

When a motion to reopen seeks to inject an entirely new issue into the proceeding, a board must consider both the criteria for reopening

the record and the standards for admitting late-filed contentions, set forth in 10 C.F.R. § 2.714(a)(1). See *Pacific Gas and Electric Co.* (Diablo Canyon Nuclear Power Plant, Units 1 and 2), CLI-82-39, 16 NRC 1712, 1714-15 (1982).

#### **RULES OF PRACTICE: ADMISSIBILITY OF CONTENTIONS**

Section 2.714(a)(1) sets out the standards for admitting late-filed contentions. They are:

- (i) Good cause, if any, for failure to file on time;
- (ii) The availability of other means whereby the petitioner's interest will be protected;
- (iii) The extent to which the petitioner's participation may reasonably be expected to assist in developing a sound record;
- (iv) The extent to which the petitioner's interest will be represented by existing parties;
- (v) The extent to which the petitioner's participation will broaden the issues or delay the proceeding.

#### **RULES OF PRACTICE: INTERLOCUTORY APPEALS**

The Appeal Board has consistently applied 10 C.F.R. § 2.714a(b) to appeals from orders that have the effect of completely denying party status to a petitioner. See, e.g., *Puget Sound Power and Light Co.* (Skagit/Hanford Nuclear Power Project, Units 1 and 2), ALAB-712, 17 NRC 81, 82 (1983). The briefing schedule for appeals from all other types of final orders, however, is that found in 10 C.F.R. § 2.762.

#### **RULES OF PRACTICE: RESPONSIBILITIES OF PARTIES**

Parties to adjudicatory proceedings have an obligation to monitor publicly available documents with a view toward raising issues in a timely fashion. *Duke Power Co.* (Catawba Nuclear Station, Units 1 and 2), CLI-83-19, 17 NRC 1041, 1048 (1983). This is particularly so with respect to environmental impact statements, which are expressly intended for public scrutiny and, if necessary, litigation.

#### **RULES OF PRACTICE: REOPENING OF PROCEEDINGS**

The most important factor of the three-factor test for reopening the record is whether the motion raises a significant safety issue.



### **APPEAL BOARDS: SCOPE OF REVIEW**

Appeal boards generally do not consider matters raised in the first instance on appeal; rather, appeals are decided on the basis of the record developed below. ALAB-819, 22 NRC 681, 720 n.51 (1985); *Houston Lighting and Power Co.* (Allens Creek Nuclear Generating Station, Unit 1), ALAB-582, 11 NRC 239, 242 (1980); *Tennessee Valley Authority* (Hartsville Nuclear Plant, Units 1A, 2A, 1B and 2B), ALAB-463, 7 NRC 341, 348 (1978).

### **RULES OF PRACTICE: BRIEFS**

Issues that a party fails to brief on appeal are considered waived. See *Public Service Electric and Gas Co.* (Salem Nuclear Generating Station, Unit 1), ALAB-650, 14 NRC 43, 49-50 (1981), *aff'd sub nom. Township of Lower Alloways Creek v. Public Service Electric and Gas Co.*, 687 F.2d 732 (3d Cir. 1982).

### **RULES OF PRACTICE: ADMISSIBILITY OF CONTENTIONS**

An appeal board will not overturn a licensing board's determination weighing the five factors specified in 10 C.F.R. § 2.714(a)(1) absent a showing that the board has abused its discretion. *Detroit Edison Co.* (Enrico Fermi Atomic Power Plant, Unit 2), ALAB-707, 16 NRC 1760, 1763 (1982).

### **RULES OF PRACTICE: SHOW-CAUSE PROCEEDINGS**

In a request under 10 C.F.R. § 2.206, any person may seek the suspension, modification, or revocation of a license, or other appropriate action, for alleged regulatory violations or potentially hazardous conditions. See 10 C.F.R. §§ 2.206(a), 2.202(a).

### **RULES OF PRACTICE: ADMISSIBILITY OF CONTENTIONS**

A petition for relief from the Director of Nuclear Reactor Regulation under 10 C.F.R. § 2.206 will not always provide adequate other means to protect a petitioner's interest, so as to satisfy the second factor of section 2.714(a)(1). Whether alternative protective means are, in fact, available depends on the issues sought to be raised, the relief requested, and the stage of the proceeding. In some circumstances, this may well require the equivalence of an adjudicatory hearing. But in other cases, a 10

C.F.R. § 2.206 petition could provide a sufficient vehicle to protect one's interest.

#### **RULES OF PRACTICE: ADMISSIBILITY OF CONTENTIONS**

In considering the admissibility of a late-filed contention, the fifth factor of 10 C.F.R. § 2.714(a)(1) requires an adjudicatory board to determine, inter alia, the extent to which the proceeding — not license issuance or plant operation — will be delayed. *Fermi*, 16 NRC at 1766.

#### **APPEARANCES**

**Robert L. Anthony**, Moylan, Pennsylvania, intervenor pro se and for intervenor Friends of the Earth.

**Troy B. Conner, Jr., Mark J. Wetterhahn, and Robert M. Rader**, Washington, D.C., for applicant Philadelphia Electric Company.

**Ann P. Hodgdon** for the Nuclear Regulatory Commission staff.

#### **MEMORANDUM AND ORDER**

We have before us an appeal from the Licensing Board's ruling denying a request by intervenors Robert L. Anthony and Friends of the Earth (Anthony/FOE) to reopen the record in this operating license proceeding.<sup>1</sup> As explained below, we affirm the Board's determination.

#### **I.**

On April 30, 1985, Anthony/FOE filed a one-page petition with the Licensing Board to reopen this proceeding for consideration of three matters: (1) the supposedly improper use of the plant site boundaries by applicant Philadelphia Electric Company (PECo) in determining the public's exposure to gaseous and liquid effluent releases during routine

---

<sup>1</sup> See Licensing Board Memorandum and Order of June 4, 1985 (unpublished).

plant operation;<sup>2</sup> (2) the claimed underestimation of radiation exposure to the public due to assertedly improper calculations regarding the fish ingestion pathway; and (3) the alleged degradation in standards for protecting the public occasioned by a revision of PECO's Offsite Dose Calculation Manual (ODCM). Anthony/FOE rely on information in PECO's Semi-Annual Effluent Releases Report No. 1 (hereafter, "Releases Report"), in particular, Attachment D (Revision 1 to the ODCM). PECO submitted this report to the Commission on February 28, 1985, in compliance with the Technical Specifications of its operating license and other staff-imposed requirements. After considering responses from PECO and the NRC staff, as well as an unauthorized reply by Anthony/FOE and a further responsive pleading filed by PECO, the Board denied Anthony/FOE's request.

In ruling on a motion to reopen the record, adjudicatory boards consider three factors: (1) whether the motion is timely; (2) whether it addresses a significant safety or environmental issue; and (3) whether a different result might have been reached had the newly proffered material been considered initially.<sup>3</sup> When a motion to reopen seeks to inject an entirely new issue into the proceeding, a board must also consider the standards for admitting late-filed contentions, set forth in 10 C.F.R. § 2.714(a)(1):

- (i) Good cause, if any, for failure to file on time.
- (ii) The availability of other means whereby the petitioner's interest will be protected.
- (iii) The extent to which the petitioner's participation may reasonably be expected to assist in developing a sound record.
- (iv) The extent to which the petitioner's interest will be represented by existing parties.
- (v) The extent to which the petitioner's participation will broaden the issues or delay the proceeding.<sup>4</sup>

<sup>2</sup> Anthony/FOE contend that the dosages should be calculated at the closest, publicly accessible approaches to the plant (a railroad right-of-way and the Schuykill River), rather than at the more distant site boundaries.

<sup>3</sup> *Metropolitan Edison Co.* (Three Mile Island Nuclear Station, Unit 1), CLI-85-2, 21 NRC 282, 285 n.3, reconsideration denied, CLI-85-7, 21 NRC 1104 (1985). The Commission's use of this test has received judicial approval. *Three Mile Island Alert, Inc. v. NRC*, 771 F.2d 720, 732 (3d Cir. 1985), citing *San Luis Obispo Mothers for Peace v. NRC*, 751 F.2d 1287, 1316-18 (D.C. Cir. 1984), vacated in part and reh'g en banc granted on other grounds, 760 F.2d 1320 (1985).

<sup>4</sup> See *Pacific Gas and Electric Co.* (Diablo Canyon Nuclear Power Plant, Units 1 and 2), CLI-82-39, 16 NRC 1712, 1714-15 (1982).

In reaching its decision, the Licensing Board examined both the criteria for reopening the record and the standards for admitting late-filed contentions. It concluded that Anthony/FOE failed to satisfy either set of requirements, prompting the instant appeal.<sup>5</sup> PECO and the staff urge affirmance of the Licensing Board's decision.<sup>6</sup>

## II.

A. Under the test for reopening the record, a petitioner must first demonstrate that it could not have presented its information at an earlier time. The Licensing Board found that the particular material in PECO's Releases Report on which Anthony/FOE base their request to reopen the record was not new or previously unavailable.<sup>7</sup> Indeed, both the Draft and Final Environmental Statements for Limerick, issued in June 1983 and April 1984, respectively, state that dose calculations are performed at the site boundary.<sup>8</sup> The Commission has made clear that parties have an obligation to monitor publicly available documents with a view toward raising issues in a timely fashion.<sup>9</sup> That is particularly so with respect to environmental impact statements, which are expressly intended for public scrutiny and, if necessary, litigation. Anthony/FOE thus could and should have voiced their concern about the calculation of doses from routine radiological releases at the plant site boundary much earlier. The Licensing Board therefore correctly concluded that, insofar

<sup>5</sup> The Licensing Board also determined, at the threshold, that it had jurisdiction to rule on Anthony/FOE's petition to reopen. The Board took note of an earlier appeal board decision in this proceeding, suggesting a pragmatic approach in deciding this type of jurisdictional question, in "the absence of any clear administrative guidance." See ALAB-726, 17 NRC 755, 758 (1983). Although no party pursues the jurisdictional issue on appeal, we agree with the Licensing Board's judgment in this regard and affirm its assertion of jurisdiction.

<sup>6</sup> PECO argues that Anthony/FOE's brief was untimely under the Commission's Rules of Practice and that their appeal should therefore be dismissed. It contends that the abbreviated schedule for briefing certain appeals set forth in 10 C.F.R. § 2.714a should pertain here, rather than the usual schedule found in 10 C.F.R. § 2.762. Applicant's Brief (July 17, 1985) at 13-14.

Although neither regulation addresses the exact situation here, we believe that section 2.762 is more applicable and that, accordingly, Anthony/FOE's brief was timely. As pertinent here, section 2.714a(b) specifically applies to appeals from board orders "wholly denying a petition for leave to intervene and/or request for a hearing" (emphasis added). We have consistently applied this provision to appeals from orders that have the effect of completely denying party status to a petitioner. See, e.g., *Puget Sound Power and Light Co.* (Skagit/Hanford Nuclear Power Project, Units 1 and 2), ALAB-712, 17 NRC 81, 82 (1983). That is not the intent or the effect of the Licensing Board's order at issue here. In this circumstance, the briefing schedule for routine appeals from final orders in section 2.762 is appropriate. (PECO does not dispute that the order in question is "final" for appeal purposes.)

<sup>7</sup> Memorandum and Order of June 4 at 5-6.

<sup>8</sup> See, e.g., NUREG-0974, Draft Environmental Statement (June 1983) at 5-47, D-5, D-9; *id.*, Final Environmental Statement (April 1984) at 5-47, D-5, D-9.

<sup>9</sup> *Duke Power Co.* (Catawba Nuclear Station, Units 1 and 2), CLI-83-19, 17 NRC 1041, 1048 (1983).

as it concerns dose calculations performed at the site boundary, the motion to reopen is not timely.<sup>10</sup>

The most important factor to consider, however, is whether the motion to reopen raises a significant safety issue. The Licensing Board concluded that Anthony/FOE's petition does not raise such an issue. Relying on staff affidavits, the Board found that Anthony/FOE's arguments are premised on factual inaccuracies and unwarranted assumptions.<sup>11</sup>

We find no basis for overturning the Board's conclusion that nothing in the petitioners' presentation raises a genuinely significant safety issue. With respect to Anthony/FOE's complaint about doses determined at the site boundary, Dr. Edward F. Branagan, Jr. (a Section Leader in the Radiological Assessment Branch of the Division of Systems Integration, Office of Nuclear Reactor Regulation), states that, although individuals could be exposed at the closer points of access urged by Anthony/FOE, it is "unlikely that these locations would be more limiting in dose calculations than the site boundary."<sup>12</sup> Dr. Branagan explains that the dose to an individual is the product of the concentration of the radionuclide *and* the occupancy time (as well as other factors). Thus, the slightly greater concentration of the radionuclide at the nearer locations identified by Anthony/FOE would be offset by the very small occupancy time there; that is, there are no permanent residences, gardens, or food-source animals at the closer locations.<sup>13</sup> In the staff's view, PECO's use of the site boundaries is therefore appropriate.

Anthony/FOE's rather sketchy argument that PECO's revision of its Offsite Dose Calculation Manual somehow violates the Commission's radiation protection standards is similarly without safety significance. As the Licensing Board noted, another staff affidavit — that of Marie T. Miller, a Radiation Specialist and inspector in Region I, where Limerick is located — states that the changes to the ODCM are in accordance with both the NRC's regulations (10 C.F.R. Part 20) and PECO's existing Technical Specifications and "do not increase the radiation risk to

---

<sup>10</sup> As we point out at note 18, *infra*, Anthony/FOE do not pursue their argument about the fish ingestion pathway on appeal; therefore, we need not decide if the motion to reopen is timely in that regard. With respect to their argument that PECO's recent (February 1985) changes to its ODCM will lead to a degradation of radiation protection standards, the record is not clear as to when Anthony/FOE actually received PECO's entire filing. In the circumstances, however, we will assume arguendo that Anthony/FOE's April 30 motion is timely, to the extent it is based on any *entirely* new information in PECO's February 1985 Releases Report.

<sup>11</sup> Memorandum and Order of June 4 at 7-9.

<sup>12</sup> NRC Staff Response to Anthony/FOE Petition to Reopen (May 28, 1985), Affidavit of Edward F. Branagan, Jr., at 3.

<sup>13</sup> *Ibid.*

the public."<sup>14</sup> Miller explains that PECO has simply revised some calculations so that it can determine "more efficiently" certain radiation alarm setpoints.<sup>15</sup>

On appeal, Anthony/FOE attempt to bolster their arguments with the affidavit of Dr. Bruce Molholt, an Adjunct Associate Professor of Health Education at Temple University. This document was not presented to the Licensing Board, and it touches on subjects that are largely beyond those Anthony/FOE sought to raise initially in their April 30 petition to reopen.<sup>16</sup> Like the courts, we generally do not consider matters raised in the first instance on appeal; rather, appeals are decided on the basis of the record developed below.<sup>17</sup> Even if Dr. Molholt's affidavit were properly before us, however, nothing in it casts doubt on the Licensing Board's conclusion concerning the lack of safety significance in Anthony/FOE's newly proposed contention.<sup>18</sup>

Inasmuch as Anthony/FOE have failed to establish the safety significance of the new matter they seek to raise, it follows that a different result would not have been reached had their arguments been considered initially. Consequently, the Licensing Board correctly concluded that the standards for reopening have not been satisfied.

B. Even if Anthony/FOE prevailed in meeting the reopening criteria, they must also show that the balancing of the five factors in 10 C.F.R. § 2.714(a)(1) justifies the admission of their new contention. The Licensing Board concluded that Anthony/FOE's petition failed in this regard as well. We will not overturn a board's determination weighing

<sup>14</sup> *Id.*, Affidavit of Marie T. Miller at 1-2.

<sup>15</sup> *Id.* at 2. See Memorandum and Order of June 4 at 8-9.

<sup>16</sup> Anthony/FOE also refer for the first time in their appellate brief to several NRC Inspection Reports, Notices of Civil Penalties, and Licensee Event Reports. Anthony/FOE Brief (July 2, 1985) at 2-3. Most of these items are totally irrelevant to their motion to reopen and/or involve matters that have been subsequently resolved.

<sup>17</sup> ALAB-819, 22 NRC 681, 720 n.51 (1985); *Houston Lighting and Power Co.* (Allens Creek Nuclear Generating Station, Unit 1), ALAB-582, 11 NRC 239, 242 (1980); *Tennessee Valley Authority* (Hartsville Nuclear Plant, Units 1A, 2A, 1B, and 2B), ALAB-463, 7 NRC 341, 348 (1978).

<sup>18</sup> For example, Dr. Molholt states that "[t]here is no reason to assume that a given individual would spend more time" at the site boundary than at the closer access points identified by Anthony/FOE. Anthony/FOE Brief, Affidavit of Bruce Molholt at 1-2. Dr. Branagan, however, has already explained the occupancy factor underlying the site boundary assumption. See p. 19, *supra*.

Dr. Molholt's affidavit also refers to radiation exposure through the fish ingestion pathway — a matter that Anthony/FOE *did* raise before the Licensing Board but have *not* pursued in their brief on appeal. Anthony/FOE have therefore waived further arguments on this score. See *Public Service Electric and Gas Co.* (Salem Nuclear Generating Station, Unit 1), ALAB-650, 14 NRC 43, 49-50 (1981), *aff'd sub nom. Township of Lower Alloways Creek v. Public Service Electric and Gas Co.*, 687 F.2d 732 (3d Cir. 1982). We note, nonetheless, that Dr. Branagan's affidavit and the Licensing Board's decision both adequately address Anthony/FOE's concern about the fish ingestion pathway. See Memorandum and Order of June 4 at 7, 9.

the five factors absent a showing that the board has abused its discretion.<sup>19</sup> Plainly, no such showing has been made here.

As noted above, the site boundary information on which Anthony/FOE predicate their request to reopen has been publicly available for some time and could have been used to formulate a contention at a much earlier stage. The Licensing Board correctly determined that Anthony/FOE have not established good cause for failure to tender their new contention in a more timely fashion.<sup>20</sup>

With regard to the second factor — the availability of other means to protect a petitioner's interest — the Licensing Board found no such other means exist and that Anthony/FOE prevail on this point.<sup>21</sup> Petitioners therefore do not contest that Board determination on appeal. PECO, however, in defending the result reached below, contends that this factor weighs against Anthony/FOE. Conceding that it is not equivalent to the admission of a contention in an adjudicatory hearing, PECO argues that a petition for relief from the Director of Nuclear Reactor Regulation (NRR) under 10 C.F.R. § 2.206 is nevertheless an adequate "other means" to protect a petitioner's interest.<sup>22</sup>

We cannot conclude that a section 2.206 petition will always provide adequate other means to protect a petitioner's interest. To do so would effectively write factor two out of the regulations. On the other hand, section 2.714(a)(1) does not specify what the term "other means" encompasses — thereby providing us with some flexibility in its interpretation.<sup>23</sup> Whether alternative protective means are, in fact, available depends on the issues sought to be raised, the relief requested, and the stage of the proceeding. In some circumstances, this may well require the equivalence of an adjudicatory hearing. But in other cases — like that here — a section 2.206 petition could provide a sufficient vehicle to protect one's interest.<sup>24</sup>

Anthony/FOE's request to reopen for hearing on their proposed new contention is based on a routine report submitted to the NRC staff by

<sup>19</sup> *Detroit Edison Co.* (Enrico Fermi Atomic Power Plant, Unit 2), ALAB-707, 16 NRC 1760, 1763 (1982).

<sup>20</sup> See Memorandum and Order of June 4 at 11.

<sup>21</sup> *Ibid.*

<sup>22</sup> Applicant's Brief at 10 n.28. In a request under section 2.206, any person may seek the suspension, modification, or revocation of a license, or other appropriate action, for alleged regulatory violations or potentially hazardous conditions. See 10 C.F.R. §§ 2.206(a), 2.202(a).

<sup>23</sup> The origin of this language does not aid in its interpretation. See 37 Fed. Reg. 9331, 9333 (1972) (notice of proposed rulemaking); 37 Fed. Reg. 15,127, 15,129 (1972) (final rule); 43 Fed. Reg. 17,798, 17,799 (1978) (final rule in existing form).

<sup>24</sup> See *Florida Power & Light Co.* (St. Lucie Nuclear Power Plant, Unit No. 2), ALAB-420, 6 NRC 8, 23 (1977), *aff'd*, CLI-78-12, 7 NRC 939 (1978) ("The rule does not say that the 'other means' must be equivalent in every respect to the intervention sought").

PECo pursuant to the requirements of the low-power operating license that had already been issued. In this limited circumstance, it is not unreasonable to view a party's right under section 2.206 to solicit more formal staff review of the concerns triggered by such a routine filing as an adequate other means for protecting its interest.<sup>25</sup> Indeed, it might well be argued that formal adjudication before a hearing board is an inappropriate and inferior vehicle for policing the scores of detailed filings routinely submitted pursuant to staff-enforced regulatory requirements.<sup>26</sup>

The Licensing Board next determined that Anthony/FOE failed to show their ability to contribute to the development of a sound record on the new matter they seek to raise. Anthony/FOE had advised the Board that they would produce a witness — Dr. Molholt — but the Board found the subject areas of his likely testimony to be lacking in the requisite specifics.<sup>27</sup> The Board's conclusion is reasonable and in accordance with past precedent.<sup>28</sup> On appeal, however, Anthony/FOE have tendered Dr. Molholt's affidavit to lend some detail to his proposed presentation. But as we noted above, Anthony/FOE cannot properly supplement on

<sup>25</sup> This is not inconsistent with our prior decisions. In *Washington Public Power Supply System* (WPPSS Nuclear Project No. 3), ALAB-747, 18 NRC 1167, 1175-76 (1963), we rejected the section 2.206 remedy as "an adequate substitute for participation in an adjudicatory proceeding concerned with the grant or denial *ab initio* of an application for an operating license." But that case involved a four-month late petition to intervene at the very outset of the proceeding, indeed, but for that single petition, there was to be no hearing at all. Given the incipient stage of the case, the contentions sought to be raised were typical of those litigated in operating license proceedings and were not, of course, triggered by routine post-license issuance filings with the staff. *See id.*, Licensing Board Memorandum and Order of September 27, 1983 (unpublished), Appendix A. Thus, in those circumstances, a section 2.206 petition could not reasonably be construed as an adequate other means to protect the petitioner's interest.

Similarly, in *Fermi*, we agreed that factor two weighed in a petitioner's favor because, in the absence of admission to the proceeding, it could not be "assured of an adjudicatory hearing." 16 NRC at 1767. But the particular emergency planning issues that petitioner sought to raise there also did not arise from any routinely filed, post-licensing reports by the applicant. In any event, we went on to describe a section 2.206 petition as a "real" remedy, explaining the thorough review and written response accorded to such filings. *Id.* at 1767-68. Compare *Nuclear Fuel Services, Inc.* (West Valley Reprocessing Plant), CLI-75-4, 1 NRC 273, 276 (1975) (availability of other means to protect petitioner's interest can depend on the circumstances of particular case); ALAB-806, 21 NRC 1183, 1190-91 (1985) (informal negotiation among parties at board-sponsored conference is not adequate other means to protect petitioner's interest); *Houston Lumber & Pever Co.* (South Texas Project, Units 1 and 2), ALAB-799, 21 NRC 360, 384 n.108 (1985) (NRC staff's normal nonadjudicatory review of a license application is not adequate other means to protect petitioner's interest); *Duke Power Co.* (Amendment to Materials License SNM-1773 — Transportation of Spent Fuel from Oconee Nuclear Station for Storage at McGuire Nuclear Station), ALAB-533, 9 NRC 146, 150 & n.7 (1979) (submitting limited appearance statement or making witnesses available to another intervenor is not adequate other means to protect petitioner's interest).

<sup>26</sup> Unlike *Fermi*, 16 NRC at 1768-69, however, we will not refer Anthony/FOE's petition to the Director of NRR. As discussed at pp. 19-20, *supra*, the petition does not raise any significant safety issues. In addition, Anthony/FOE apparently have already filed a section 2.206 petition with the Director concerning some of the same matters they raise here.

<sup>27</sup> Memorandum and Order of June 4 at 12.

<sup>28</sup> Compare ALAB-806, 21 NRC at 1191-92, with *Mississippi Power and Light Co.* (Grand Gulf Nuclear Station, Units 1 and 2), ALAB-704, 16 NRC 1725, 1730 (1982).



appeal the information that was before the Licensing Board at the time of its decision.<sup>29</sup>

The Licensing Board found no other existing party that could represent Anthony/FOE's interest and thus weighed the fourth factor in their favor.<sup>30</sup> We agree.

Finally, the Board concluded that the introduction of any new contention at this stage of the case would broaden the issues and delay the proceeding.<sup>31</sup> But Anthony/FOE argue that reopening the record for hearing on the issues they raise here is essential to the protection of the public health and safety and overrides any possible delay in issuance of a full-power license.

At the outset, we note that the Commission's regulations require a licensing board to determine whether the proceeding — not license issuance or plant operation — will be delayed.<sup>32</sup> We agree with Anthony/FOE, however, that the public health and safety must be a preeminent concern where significant issues have been raised. But as shown above, the matters involved here do not rise to that level.<sup>33</sup>

In sum, Anthony/FOE have not demonstrated that a balancing of the five factors in 10 C.F.R. § 2.714(a)(1) favors the admission and litigation of their new contention based on PECO's Semi-Annual Effluent Releases Report.

---

The Licensing Board's Memorandum and Order of June 4, 1985, is *affirmed*.

It is so ORDERED.

FOR THE APPEAL BOARD

C. Jean Shoemaker  
Secretary to the  
Appeal Board

---

<sup>29</sup> See p. 20, *supra*.

<sup>30</sup> Memorandum and Order of June 4 at 12.

<sup>31</sup> *Ibid.*

<sup>32</sup> *Fermi*, 16 NRC at 1766. In any event, since the time the petition to reopen was filed, the Licensing Board has completed all hearings and issued its final partial initial decision resolving in PECO's favor the remaining contested issues and authorizing issuance of a full-power operating license. The Commission made the Board's decision effective, and the plant is in operation. See CLI-85-15, 22 NRC 184 (1985).

<sup>33</sup> See pp. 19-20, *supra*.

# Atomic Safety and Licensing Boards Issuances

## ATOMIC SAFETY AND LICENSING BOARD PANEL

B. Paul Cotter, \**Chairman*  
Robert M. Lazo, \**Vice Chairman (Executive)*  
Frederick J. Shon, \**Vice Chairman (Technical)*

### Members

Dr. George C. Anderson	James P. Gleason	Dr. Linda W. Little
Charles Bechhoefer*	Andrew C. Goodhope	Dr. Emmeth A. Luebke*
Peter B. Bloch*	Herbert Grossman*	Dr. Kenneth A. McCollom
Lawrence Brenner*	Dr. Cadet H. Hand, Jr.	Morton B. Margulies*
Glenn O. Bright*	Jerry Harbour*	Gary L. Milhollin
Dr. A. Dixon Callihan	Dr. David L. Hetrick	Marshall E. Miller
James H. Carpenter*	Ernest E. Hill	Dr. Peter A. Morris*
Hugh K. Clark	Dr. Frank F. Hooper	Dr. Oscar H. Paris*
Dr. Richard F. Cole*	Helen F. Hoyt*	Dr. Paul W. Purdom
Dr. Frederick R. Cowan	Elizabeth B. Johnson	Dr. David R. Schink
Dr. Michael A. Duggan	Dr. Walter H. Jordan	Ivan W. Smith*
Dr. George A. Ferguson	James L. Kelley*	Dr. Martin J. Steindler
Dr. Harry Foreman	Jerry R. Kline*	Dr. Quentin J. Stober
Richard F. Foster	Dr. James C. Lamb III	Seymour Wenner
John H. Frye III*	Gustave A. Linenberger*	Sheldon J. Wolfe*

\**Permanent panel members*

UNITED STATES OF AMERICA  
NUCLEAR REGULATORY COMMISSION

**ATOMIC SAFETY AND LICENSING BOARD**

**Before Administrative Judges:**

**Robert M. Lazo, Chairman**  
**Gustave A. Lindenberger**  
**David R. Schink**

**In the Matter of**

**Docket No. 50-133-OLA**  
**(ASLBP No. 77-357-07-LA)**  
**(Amendment to Facility**  
**Operating License)**

**PACIFIC GAS AND ELECTRIC**  
**COMPANY**  
**(Humboldt Bay Power Plant,**  
**Unit 3)**

**January 14, 1986**

The Licensing Board grants Licensee's motion to withdraw its license amendment application and dismisses the proceeding.

**MEMORANDUM AND ORDER TERMINATING**  
**PROCEEDING**

On October 11, 1985, the NRC Staff (Staff) filed a motion with the Licensing Board seeking an order dismissing the above-identified proceeding. In its motion the Staff argued that (1) the matter was moot because the Pacific Gas and Electric Company (Licensee) had sought to withdraw its application for a license amendment which was the subject of this proceeding and had submitted an application for decommissioning

pursuant to which the Staff had recently amended the operating license to authorize "possession only" of the facility and (2) the Board did not have jurisdiction to consider the decommissioning application, but rather a separate proceeding and opportunity for a hearing on the decommissioning would be available when the Staff noticed for consideration the decommissioning application.

The Licensee filed a response on October 28, 1985, in support of the Staff's motion. No opposition and indeed no other response to the Staff's motion have been filed by any of the other parties to the proceeding.<sup>1</sup>

The Licensing Board has carefully considered the "NRC Staff Motion to Terminate Proceeding" and the response filed by Licensee and for the reasons set forth therein agrees that this proceeding should be dismissed. The submission of Licensee's decommissioning plan renders moot the amendment application which is the subject of this proceeding and any issue pertaining to the contested application. As a result, there are now no issues in dispute which are within the Licensing Board's jurisdiction to decide. Moreover, there will be an opportunity for interested persons to request a hearing on the decommissioning application submitted by Licensee. Accordingly, there is no reason to hold a hearing in this proceeding or for the Licensing Board to retain jurisdiction.

#### ORDER

For the foregoing reasons and in consideration of the entire record in this matter, it is, this 14th day of January 1986,

#### ORDERED

1. Licensee's motion of December 31, 1980, to withdraw its application for an amendment to permit resumption of power operation and to terminate further action on the application is hereby *granted*;

---

<sup>1</sup> The other parties to this proceeding are the Joint Intervenors, Thomas K. Collins, Dr. Elmont Honea, Frederick P. Cranston, Wesley Chesbro, Demetrios L. Mitsanas, Six Rivers Branch of Friends of the Earth, and the Sierra Club.

2. The NRC Staff's motion of October 11, 1985, seeking an order dismissing this proceeding is hereby *granted*; and
3. This license amendment proceeding is *dismissed*.

FOR THE ATOMIC SAFETY AND  
LICENSING BOARD

Robert M. Lazo, Chairman  
ADMINISTRATIVE JUDGE

Dated at Bethesda, Maryland,  
this 14th day of January 1986.

Cite as 23 NRC 28 (1986)

**LBP-86-2**

UNITED STATES OF AMERICA  
NUCLEAR REGULATORY COMMISSION

Before Administrative Judge:

Dr. Jerry R. Kline

In the Matter of

Docket No. 30-22063  
(ASLBP No. 85-512-02-ML)

**PRECISION MATERIALS  
CORPORATION**  
(Mine Hill, New Jersey  
Irradiator Facility)

January 28, 1986

**MEMORANDUM AND ORDER**  
(Dismissing the Case)

The Presiding Officer was notified by letter dated January 21, 1986, from Mine Hill's representative that the Township of Mine Hill withdraws its previously filed request for a hearing regarding the issuance of a license to Precision Materials Corporation to operate an irradiator facility in Mine Hill Township. Mine Hill's withdrawal of its request for hearing results in there being no disputed issues to be resolved in this case.

The NRC Staff previously conducted a safety review of Precision Materials' Irradiator Facility. That review resulted in the issuance of an NRC Materials License to Precision Materials Corporation permitting it to possess and use byproduct materials under conditions specified in the license.

In the absence of disputed issues, the presiding officer may rely on the Staff safety review and the licensing conditions imposed by the Staff for reasonable assurance that the facility will be operated in a manner consistent with the protection of public health and safety and in accordance with NRC regulations. For these reasons, it is concluded that an in-

formal hearing is now unnecessary and that the case should be dismissed.

Accordingly, for all of the foregoing reasons and in consideration of the entire record, it is, on this 28th day of January 1986,

**ORDERED**

1. This case is dismissed because there are no disputed issues to be resolved.

2. No changes in any license provision or licensing condition are imposed or approved as a result of this proceeding. Precision Materials Corporation materials license, as amended August 2, 1985, remains in effect.

3. This is the final decision by the presiding officer in this case. In accordance with the Commission Order of July 24, 1985, this decision will become final agency action 30 days after the date of issuance, unless the Commission on its own motion undertakes a review of the decision. No petition for review will be entertained by the Commission regarding the presiding officer's decision.

Jerry R. Kline  
ADMINISTRATIVE JUDGE

Dated at Bethesda, Maryland,  
this 28th day of January 1986.

Administrative  
Law Judge

ADMINISTRATIVE LAW JUDGE



UNITED STATES OF AMERICA  
NUCLEAR REGULATORY COMMISSION

ADMINISTRATIVE LAW JUDGE

Ivan W. Smith

In the Matter of

Docket No. 55-60575  
(ASLBP No. 86-515-01-SP)  
(Senior Operator License for  
Millstone Nuclear Power  
Station, Unit 3)

KENNETH L. BURTON

January 27, 1986

ORDER TERMINATING PROCEEDING

Kenneth L. Burton's application for a senior reactor operator's license for the Millstone Nuclear Power Station Unit 3 was denied by the NRC Staff on the asserted basis that he had failed the simulator portion of his May 23, 1985 licensing examination. Mr. Burton requested a hearing on the denial. The Commission, by order of October 10, 1985, granted the request. Subsequently, on October 15, 1985, the NRC Staff informed Mr. Burton that the simulator examination of May 23 was invalid as "a determination of either successful performance or failure." Mr. Burton participated in another simulator examination on October 30, 1985, which he passed. His senior reactor operator's license has since been issued.

Now Mr. Burton and the NRC Staff, by joint motion dated January 2 and 7, 1986, move that the proceeding be terminated as unnecessary

and unwarranted. I agree. There is no issue to be decided. The joint motion is granted.

IT IS THEREFORE ORDERED that this proceeding be terminated.

Ivan W. Smith  
Administrative Law Judge

Bethesda, Maryland  
January 27, 1986

Directors'  
Decisions  
Under  
10 CFR 2.206

DIRECTORS' DECISIONS

UNITED STATES OF AMERICA  
NUCLEAR REGULATORY COMMISSION

OFFICE OF NUCLEAR REACTOR REGULATION

Harold R. Denton, Director

In the Matter of

<b>ARKANSAS POWER AND LIGHT COMPANY</b> (Arkansas Nuclear One, Unit 1)	Docket No. 50-313
<b>SACRAMENTO MUNICIPAL UTILITY DISTRICT</b> (Rancho Seco Nuclear Generating Station)	Docket No. 50-312
<b>FLORIDA POWER CORPORATION</b> (Crystal River Unit No. 3 Nuclear Generating Plant)	Docket No. 50-302
<b>DUKE POWER COMPANY, et al.</b> (Oconee Nuclear Station, Units 1, 2, and 3)	Docket Nos. 50-269 50-270 50-287
<b>GENERAL PUBLIC UTILITIES NUCLEAR CORPORATION</b> (Three Mile Island Nuclear Station, Unit 1)	Docket No. 50-289  January 29, 1986

The Director of the Office of Nuclear Reactor Regulation denies the petition of Mr. John Doherty requesting institution of proceedings to

\*This Decision was originally issued on December 4, 1985, but later withdrawn. It was replaced with the Decision of January 29, 1986.

show cause why the operating licenses for certain named facilities should not be suspended or revoked until alleged problems associated with operation of control rod drive mechanisms at the facilities are resolved.

## **DIRECTOR'S DECISION UNDER 10 C.F.R. § 2.206**

### **INTRODUCTION**

On June 11, 1985, Mr. John Doherty (Petitioner) filed his Petition/Request for Show Cause Order (Petition) requesting issuance of an order under 10 C.F.R. § 2.202 to the licensees of Arkansas Nuclear One, Unit 1; Rancho Seco Nuclear Generating Station; Crystal River Unit No. 3 Nuclear Generating Plant; Oconee Nuclear Station, Units 1, 2, and 3; and Three Mile Island Nuclear Station, Unit 1, to show cause why the operating licenses for those facilities should not be suspended or revoked until the problem identified in IE Information Notice No. 85-38 is resolved.<sup>1</sup> The IE Notice concerned loose parts which had been found to obstruct certain control rod drive mechanisms (CRDMs) at the Davis-Besse facility of the Toledo Edison Company. The CRDMs at Davis-Besse are manufactured by the Babcock and Wilcox Co. (B&W) as are those at the other facilities identified above.

On July 17, 1985, I acknowledged receipt of Mr. Doherty's petition. I informed him that his petition would be treated under 10 C.F.R. § 2.206 of the Commission's regulations and that I would issue a decision within a reasonable amount of time. My decision in this matter follows. I have also considered in my decision the Response of the Arkansas Power and Light Co. dated September 10, 1985.

### **DISCUSSION**

The events which prompted the IE Notice occurred at Davis-Besse. On June 25, 1981, CRDM C-7 failed to withdraw. It was found that a leaf spring which is used to hold an antirotation key for the central screw shaft in place had broken. A piece of the spring became jammed in the CRDM after several cycles of raising and lowering and prevented the

---

<sup>1</sup> IE Information Notice No. 85-38, "Loose Parts Obstruct Control Rod Drive Mechanism," dated May 24, 1985 (hereinafter referred to as the IE Notice).

raising of the rod from the fully inserted position. It has since been discovered that the leaf spring can break if the antirotation key is not inserted in its slot and if all dimensional tolerances are stacked in the most adverse direction. In that circumstance, the tip of the spring will hit the torque tube cap when the CRDM is fully withdrawn (see Enclosure). If the leaf spring then breaks and if the right size of debris is generated, i.e., not too large or too small, either immediately or due to exercising the CRDM, then such a loose part can cause either improper functioning of the CRDM, or prevent the rod from being inserted, or prevent the rod from being withdrawn.

On March 16, 1985, CRDM E-3 at Davis-Besse did not drop into the core on demand. The rod was inserted using the roller nuts.<sup>2</sup> It was discovered that the cause of the failure to drop was the presence of a piece of a set screw from an inspection tool. In addition, it was discovered that the leaf spring for CRDM E-3 had broken due to the mechanism described above and part of it was in the CRDM mechanism. The leaf spring part did not cause the failure of the CRDM to drop. It is evident that a potential common-mode failure mechanism exists for B&W CRDMs if the antirotation keys are not properly placed in their slots in the lead screws.<sup>3</sup> However, if the antirotation keys are positively verified to be properly in place, there is no physical mechanism or procedure which will displace the leaf springs and thus no common-mode failure potential. All B&W plants now use a procedure for removal of CRDM components which allows the springs to remain in place during disassembly or installation.

In summary, the only identified cause of leaf spring failure is improper installation of the spring. There is no identified mechanism by which a properly installed spring will back out to the position where it could be broken. Therefore, a completed inspection of leaf spring installation adequately resolves this issue.

---

<sup>2</sup> The control rod drive mechanisms at B&W plants all utilize a similar design. Essentially it consists of a central screw shaft which does not rotate. A motorized rotor mechanism with four roller nuts engages the shaft and, when this rotor mechanism turns, the central screw shaft, to which the control rods are attached, is lifted or lowered for normal plant operation. In the event of a reactor scram, or if power is lost, the roller nuts, which are held in place against the central screw shaft by a magnetic clutch, disengage from the central screw shaft and the control rod bundle drops by gravity into the core. The system is failsafe because loss of power disengages the magnetic clutch. In the accident scenarios, no credit is taken for the ability to lower the control rod into the core against an opposing force by use of the roller nuts. The ability of the roller nuts to disengage from the central screw shaft and thus cause the rod to drop by gravity is the only safety-related function of the roller nut mechanism. As demonstrated at Davis-Besse, the roller nut mechanism is capable of being used to drive the control rods into the core against an opposing force.

<sup>3</sup> The introduction of a loose part into the CRDM from a handling tool as also occurred at Davis-Besse is considered a unique occurrence and not a common-mode failure.

At Davis-Besse, Crystal River, Oconee 2, and Rancho Seco, the CRDM leaf springs were positively verified to be in place during recent outages. Oconee 3 will be entering an outage imminently and will verify the position of its CRDM leaf springs during the outage. Oconee 1, TMI-1, and Arkansas will verify the position of their leaf springs at the next refueling outage for each plant. This will take place within the next 6 and 10 months at Oconee 1 and Arkansas, respectively, and within about 6 months after startup at TMI-1. This is acceptable for the following reasons:

1. Rod drop times have been verified to be within acceptable limits for the plants which have not inspected leaf springs during recent outages. Thus, there is no present indication that CRDMs at these facilities would fail.
2. By Technical Specifications, control rods which are not fully inserted are exercised periodically during operation by moving each rod slightly (2 to 3%) to be sure that they respond to control and are free to move. If any one control rod were to be found inoperable as the result of excessive friction or mechanical interference, the plant would have to be shut down to hot standby within 6 hours. In no case would a plant continue to operate with even one control rod inoperable due to excessive friction or mechanical interference.
3. The presence of loose parts would likely give warning of potential interference during either rod drop tests, periodic rod motion tests, or, for rods in the control group, during normal operation. Only a loose part of a very specific size can cause an interference. If the part is too large or too small, it will not interfere with dropping or insertion of the rods. If the part is too large, it will remain above the roller nuts and will not interfere with them disengaging. If the part is too small, it will drop to the bottom of the CRDM tube and cause no interference. If the part is of a size which might cause interference, it is likely to slow down the drop time before causing the rod to jam. This will be detected during the testing prior to starting up in most cases. Further, if the failure occurred during operation, it is likely that the mechanism would not function properly during periodic rod motion tests or, for rods in the control group, during normal rod motion. If an inoperable rod is detected during operation, the plant is required to shut down. Though it is theoretically possible for the fragment to lodge in the mechanism in such a way that it would not interfere with normal operation yet would prevent the mechanism from unlatching, a

careful analysis of the mechanism design shows this to be extremely unlikely.

With the procedural controls now in place to ensure proper positioning of the leaf springs, CRDMs which have been inspected and verified are ensured to operate properly. As for those plants operating now without having completed the inspection, the risk from short-time operation is considered adequately low. First, from the rod drop test run at startup, there is a reasonable basis for believing the mechanism was not jammed at that time. Second, periodic rod motion tests are likely to identify any mechanism failure occurring since startup. Third, there is a general requirement that all reactors be designed such that no fuel damage occurs for any scram event if the single most reactive rod fails to insert. Therefore, in order for any damage of the core to occur, at least two, and in most situations considerably more than two, rods must fail to insert. Given the improbability of a mechanism failure occurring and not being detected by rod drop or rod motion tests, it is considered extraordinarily unlikely that, in the relatively short period of operation prior to the inspection of the leaf springs, two rods would fail to drop or to be inserted into the core when required because of previously undetected failures. Therefore, continued operation until the inspection of the leaf springs is acceptable.

### CONCLUSION

For the reasons stated above, there is adequate assurance that CRDMs at B&W facilities will operate properly when needed. Consequently, initiation of show cause proceedings as requested by Petitioner is not appropriate. Accordingly, Petitioner's request for action pursuant to 10 C.F.R. § 2.206 is denied. As provided in 10 C.F.R. 2.206(c), a copy of this Decision will be filed with the Secretary for the Commission's review.

Harold R. Denton, Director  
Office of Nuclear Reactor  
Regulation

Dated at Bethesda, Maryland,  
this 29th day of January 1986.



88

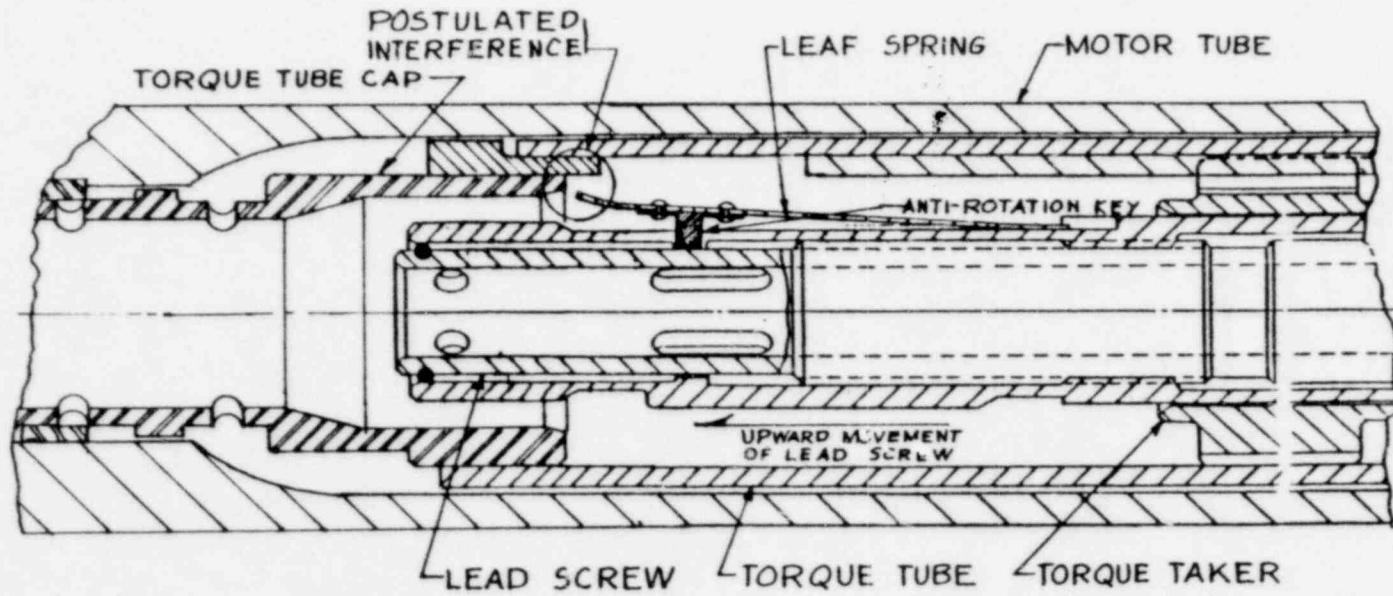

**ENCLOSURE**

**Cross-section of lead screw assembly with leaf spring in unlatched position. (NOTE: Interference of the leaf spring at the torque tube cap was the result of the antirotation key on the leaf spring not being properly positioned in the slot on the lead screw.)**

UNITED STATES OF AMERICA  
NUCLEAR REGULATORY COMMISSION

OFFICE OF NUCLEAR REACTOR REGULATION

Darrell G. Eisenhut, Acting Director

In the Matter of

Docket No. 50-352  
(10 C.F.R. § 2.206)

PHILADELPHIA ELECTRIC COMPANY  
(Limerick Generating Station,  
Unit 1)

January 21, 1986

The Acting Director of Nuclear Reactor Regulation denies petitions filed by Robert L. Anthony and Frank R. Romano which sought revocation of certain exemptions from NRC regulations issued by the NRC Staff for operation of Limerick Generating Station, Unit 1. The petitioners had not identified any safety or environmental information that would warrant a change in the Staff's previous conclusions regarding the exemptions.

**RULES OF PRACTICE: PETITIONS UNDER 10 C.F.R. § 2.206**

In the absence of an adequate factual basis for a petition or a nexus between the issues raised in the petition and the request for relief, no action need be taken on a petition under 10 C.F.R. § 2.206. Matters which are before the Board in a licensing proceeding are not the appropriate subject of a § 2.206 petition.

## DIRECTOR'S DECISION UNDER 10 C.F.R. § 2.206

### INTRODUCTION

On July 26, 1985, Robert L. Anthony on behalf of himself and Friends of the Earth filed with the Commission an "appeal" seeking Commission revocation of certain exemptions from NRC regulations issued by the NRC Staff to the Philadelphia Electric Company (PECo or the Licensee) for the Limerick Generating Station, Unit 1. Mr. Anthony also appealed the NRC Staff's determination, as set forth in the Staff's environmental assessment report dated June 27, 1985, that an environmental impact statement was not required for these actions and that the actions will not have a significant effect on the quality of the human environment. The Commission, by Order dated August 8, 1985 (unpublished), noted that NRC regulations do not provide for an appeal from the issuance of exemptions and referred the matter to the Director of Nuclear Reactor Regulation for appropriate action. By letter dated August 30, 1985, to Mr. Anthony, I acknowledged receipt of the petition and informed him that it would be reviewed. The Staff has treated Mr. Anthony's "appeal" as a request for action pursuant to 10 C.F.R. § 2.206.

On August 8, 1985, Mr. Frank R. Romano, on behalf of himself and Air and Water Pollution Patrol (AWPP), filed a document with the Atomic Safety and Licensing Appeal Board which also addresses the same subjects as Mr. Anthony's July 26, 1985 letter. By Order dated August 12, 1985 (unpublished), the Appeal Board referred Mr. Romano's comments to the Office of Nuclear Reactor Regulation for appropriate action. In my acknowledgment letter to Mr. Anthony of August 30, 1985, I also noted that I would consider Mr. Romano's comments when responding to these matters. A notice was published in the *Federal Register* stating that Mr. Anthony's and Mr. Romano's requests were under consideration. See 50 Fed. Reg. 36,934 (Sept. 10, 1985). My decision in this matter follows.

### DISCUSSION

Petitioners seek the revocation of eight specific exemptions from NRC regulations that were granted with the issuance of the operating

license<sup>1</sup> for the Limerick Generating Station, Unit 1. Petitioners also disagree that the NRC Staff's environmental assessment<sup>2</sup> of the effects of these exemptions is sufficient and seek to have the NRC Staff prepare an environmental impact statement on these issues.

The eight exemptions have previously been addressed at length in submittals by the Licensee, by the NRC Staff in the Safety Evaluation Report (SER) and Supplements (SSERs) thereto, and in the NRC Staff's environmental assessment mentioned above. All but one of them were addressed in a previous Director's Decision<sup>3</sup> pursuant to § 2.206 in response to a petition by Mr. Anthony and others. A summary of the exemptions is provided below:

- A. An exemption from General Design Criterion (GDC) 61 for the standby gas treatment system would allow a delay until the first refueling outage for installation of the portion of the system serving the refueling floor area. The principal basis for the exemption was an absence of irradiated fuel in the refueling zone area prior to the first refueling and the demonstrated leak-tight integrity of the Unit 1 secondary containment zone which interfaces with the refueling zone.
- B. Further provisions for automatic containment isolation of the hydrogen recombiner lines, the reactor enclosure cooling water lines, and the drywell chilled water lines are allowed to be completed prior to completion of the first refueling outage. This exemption from GDC 56 was based principally on the limited time of its effectiveness and the already existing features of the designs which provide isolation of these lines.
- C. An exemption from the requirements of GDC 19 for the remote shutdown system would allow reliance on manual actions in accordance with established procedures to control three pumps in the redundant (backup) train of remote shutdown system equipment until completion of the first refueling outage. This exemption was based principally on the currently existing features of the design, which provide an interim alternate means of using both trains of the remote shutdown equipment if required, and the low probability of demand for use of

---

<sup>1</sup> The initial operating license (License No. NPF-27) for Limerick Unit 1, restricted to 5% of rated power, was issued on October 26, 1984. The current full-power operating license (License No. NPF-39), which supercedes the previously issued license, was issued on August 8, 1985.

<sup>2</sup> Letter, Walter R. Butler, NRC, to E.G. Bauer, Jr., PECO, "Notice of Preparation of Environmental Assessment," dated June 27, 1985, and subsequently published in the *Federal Register*, 50 Fed. Reg. 27,388 (July 2, 1985).

<sup>3</sup> Director's Decision Under 10 C.F.R. § 2.206, DD-85-11, 22 NRC 149, 153-58 (1985). The Commission did not overturn the Director's Decision.

the remote shutdown systems during the period of the exemption.

- D. The exemption from Appendix J for the containment airlock testing allows substitution of an airlock door seal test for an airlock chamber pressure test while the reactor is in a shutdown or refueling mode. The exemption was based principally on the adequacy of other testing required by Appendix J and the Unit 1 Technical Specifications which will ensure adequate containment leaktight integrity when required.
- E. Exemptions from Appendix J for the main steam isolation valve (MSIV) leakage testing allow the test to be conducted on the specific Unit 1 MSIV design in a manner which produces meaningful data. The exemption was based principally on facilitating a meaningful test and on the conclusion that the consequences of MSIV leakage at rates verified by testing in this manner have been acceptably analyzed and bounded in the Unit 1 safety analyses.
- F. The exemption from Appendix J for the traversing incore probe guide tube shear valves allows reliance upon surveillance provisions in lieu of in-place testing of the explosively actuated shear valves. The exemption was based principally on the adequacy of the surveillance measures as included in the Unit 1 Technical Specifications to provide assurance of containment isolability when required.
- G. The exemption from Appendix J for the residual heat removal system relief valves allows the initial local leak rate test on seven valves to be delayed until the first refueling outage. The principal bases for the exemption were several features of the design which provided reasonable assurance against undue valve leakage during the period of the exemption.
- H. The exemption from 10 C.F.R. § 50.44 for containment inerting allows the initial inerting of the containment to be postponed from 6 months after initial criticality until a later milestone associated with the progress of the initial power ascension test program (PATP). The bases for the exemption were the provision of improved safety measures for personnel entering the containment during the PATP and maintenance of the same degree of protection against combustible gas inside containment as otherwise required by § 50.44.

### **Petitioners' Challenge to the Bases for the Exemptions**

Petitioners raise two central issues, the adequacy of the technical basis for the exemptions and whether an environmental impact statement should have been prepared for the issuance of the exemptions. As noted above, the exemptions were previously addressed in the Licensee's submittals and the Staff's SER, SSERs, environmental impact appraisals, and the earlier § 2.206 decision on this subject. I shall respond here to the brief comments of the petitioners on these issues.

### **Routine Releases**

Mr. Anthony states that the impact from routine releases due to these exemptions has been overlooked, and he makes reference to other documents<sup>4</sup> in support of this allegation. The features of the plant design and operation which are the subject of these exemptions are provided to mitigate the consequences of accidents. These features, as addressed by the exemption, are not employed in the day-to-day operation of the plant to control routine releases of effluents. No further basis for this allegation, other than reference to the two documents cited in note 4, is provided. The other documents which Mr. Anthony references, were submitted to the Licensing Board and the Appeal Board and addressed the Licensee's semiannual effluent release report and the offsite dose calculation manual, including the method used to calculate doses at the site boundaries. None of these matters bears any cognizable significance to the subject of the eight exemptions, and Mr. Anthony provides no information to connect them. In the absence of a specific factual basis, I need take no further action with respect to Mr. Anthony's claims concerning routine releases.<sup>5</sup> The matters raised in Mr. Anthony's April 30th and July 2nd filings are still before the Appeal Board for its consideration and, therefore, no further action by me pursuant to § 2.206 is appropriate on these matters.<sup>6</sup> Accordingly I will not consider this issue further.

---

<sup>4</sup> Robert L. Anthony, "Petition by Anthony/FOE to Reopen the Record on the Basis of New Information in Phila. Elec. Co.'s Semi-Annual Effluent Release Report, Feb. 1985," April 30, 1985, before the Atomic Safety and Licensing Board; Robert L. Anthony, "Anthony/FOE Brief in Support of Our Appeal of 6/7/85 from ASLB Mem. Order of 6/4/84," July 2, 1985, before the Atomic Safety and Licensing Appeal Board. The Licensing Board denied the April 30th petition in a Memorandum and Order dated June 4, 1985 (unpublished). The Board's action was followed by the filing of an appeal and the supporting July 2, 1985 brief by Mr. Anthony. The Appeal Board has not yet rendered a decision on the appeal.

<sup>5</sup> See *Philadelphia Electric Co.* (Limerick Generating Station, Units 1 and 2), DD-82-13, 16 NRC 2115, 2121 (1982) and cases there cited; see also DD-85-11, *supra* note 3, 22 NRC at 154.

<sup>6</sup> *General Public Utilities Nuclear Corp.* (Three Mile Island Nuclear Station, Units 1 and 2; Oyster Creek Nuclear Generating Station), CLI-85-4, 21 NRC 561 (1985); *Pacific Gas and Electric Co.* (Diablo  
(Continued)

### Effect of Exemptions on Accident Analyses

Mr. Anthony makes several brief assertions regarding the effect of the exemptions on accident analyses. He argues that, with respect to the standby gas treatment system (SGTS), a path is left open for the escape of radioactivity. However, this argument does not reflect the true circumstances of the situation, namely that there will be no irradiated fuel in the refueling area during the period of the exemption. Thus, the exemption permits no increased risk to the public of radioactive release which would require mitigation by the SGTS.

Mr. Anthony also asserts that waiting until the first refueling outage to install the redundant isolation valves in the hydrogen recombiner lines that penetrate the primary containment would also contribute to the risk of leakage to the refueling floor. This suggestion that the isolation provisions are inadequate for these lines during the period of the exemption does not recognize the basis for the Staff's conclusions as presented in Supplement 1 to the Safety Evaluation Report (SSER). SSER No. 1 included a discussion of the capability of the existing single isolation valve in each line, the closed nature of the recombiner and its piping outside the containment boundary, the pressure and temperature rating of the recombiner system components, and other aspects of the design which support granting the exemption until the first refueling outage. Mr. Anthony provides no further information beyond a mere assertion that the recombiner system, in its present design configuration, could contribute to leakage to the refueling floor. For the reasons discussed above there would be no increased risk, and thus, I see no basis to withdraw the exemption.

The Petition also makes several brief unsupported assertions that the use of the interim measures to control equipment in the redundant train of remote shutdown equipment and the containment airlock testing provisions are not allowed by NRC regulations. The bases reviewed by the NRC Staff for the applicable exemptions are discussed at length in the SER and in SSER No. 3.<sup>7</sup> Mr. Anthony provides no information regarding those bases to support his assertions and provides no information regarding why the requirements of the NRC regulations in 10 C.F.R. § 50.12, which provides for the granting of exemptions, have not been met in these instances. In the absence of any specific factual basis for these assertions, they will not be considered further.<sup>8</sup>

---

Canyon Nuclear Power Plant, Units 1 and 2), CLI-81-6, 13 NRC 443, 444 (1981). In all events the NRC Staff responded on May 28 and August 16, 1985, to the substance of Mr. Anthony's filings in the operating license proceeding and concluded that they fail to raise any significant safety issue.

<sup>7</sup> See also DD-85-11, *supra* note 3, 22 NRC at 154-57.

<sup>8</sup> DD-82-13, *supra* note 5, 16 NRC at 2121, and cases cited therein.

### **Basis for the Environmental Assessment**

Both petitioners assert that there was no basis for issuing the exemptions on the assumption of no environmental harm and that NRC must revoke the exemptions and require an environmental impact statement.

NRC regulations in 10 C.F.R. Part 51 specify the nature of the environmental review, if any, that must be conducted for a given licensing or regulatory action. Under 10 C.F.R. § 51.21 all licensing and regulatory actions subject to Part 51 require an environmental assessment, except those specifically identified in 10 C.F.R. § 51.20(b) as requiring an environmental impact statement and those identified in 10 C.F.R. § 51.22(c) as categorical exclusions. The requested exemptions for the Limerick plant do not fall within the criteria for a required environmental impact statement under § 51.20(b) and are not explicitly included under the categorical exclusions in § 51.22(c). Therefore, an environmental assessment of the exemptions was prepared to determine whether to prepare an environmental impact statement or to find no significant environmental impact.

In assessing the appropriate action for the eight subject exemptions, I note that the characteristics of these actions are consistent with those characteristics of categorical exclusions for which no further environmental evaluation would be necessary. For example, all of the eight exemptions are expected to affect portions of the plant only within the restricted area, as defined in 10 C.F.R. Part 20, to involve no significant hazards consideration, to involve no significant change in effluent releases off site and to involve no significant change in occupational radiation exposure. *See* 10 C.F.R. § 51.22(c)(9). Apart from Mr. Anthony's assertion (rebutted above) that certain exemptions increase the risk of accidental releases, neither petitioner provides support for his disagreement with the Staff's conclusions that the exemptions will have no significant impact on the human environment and that an environmental impact statement was not required.

Mr. Anthony also asserts that alternatives were not considered but provides no information regarding what alternatives he believes should have been considered. Contrary to the assertion, alternatives to granting the exemption were considered. Relief from the specific requirements of the regulations was granted in each case in conjunction with the finding that other features of the plant design or administrative actions would exist or would be required which would compensate substantially for the relief granted by the exemption. This approach provides a comparable level of protection of the public health and safety and results in an insignificant difference in the environmental impacts such that granting of



the exemptions under § 50.12 and the decision not to prepare an environmental impact statement under Part 51 were appropriate.

As noted in the environmental assessment, the principal alternative would have been to deny the exemptions which, given the comparable protection provided by the exemptions, would not have resulted in a significantly greater level of safety over the life of the plant and would not have resulted in a significant reduction in environmental impacts. Denial of the exemptions would have contributed to delays in completion and final readiness testing of systems according to the Licensee's assessment, would have resulted in some unnecessary testing requirements, and would have increased the hazard to personnel entering the containment during the startup test program. As noted in the environmental assessment, denial of the exemptions would have resulted in reduced operational flexibility and unwarranted delays in power ascension in view of the negligible environmental impacts engendered by the exemptions. Under § 50.12, the Commission may give appropriate consideration to the effect on the public interest of any delay from not granting an exemption, including power needs and delay costs to the applicant and to the consumer. In sum, the discussion in the environmental assessment of the exemptions was appropriate to the circumstances, and no more detailed examination or balancing of alternatives was required.<sup>9</sup>

In his request Mr. Romano briefly mentions, without any particular nexus to the exemptions at issue, several issues previously raised and decided before the Licensing Board concerning asbestos and vinyl chloride contamination of the Schuylkill River. This issue has been raised before the Licensing Board and was discussed by the Board in the operating license proceeding.<sup>10</sup> No further action on my part with respect to this issue is appropriate here.<sup>11</sup>

## CONCLUSION

With respect to the bases for and the environmental evaluation of eight specific exemptions issued with the operating license for the Limerick Generating Station, Unit 1, the petitioners have not identified any

---

<sup>9</sup> See *Duke Power Co.* (Amendment to Materials License SNM-1773 - Transportation of Spent Fuel from Oconee Nuclear Station for Storage at McGuire Nuclear Station), ALAB-651, 14 NRC 307, 317 (1981); *Virginia Electric and Power Co.* (North Anna Power Station, Units 1 and 2), ALAB-584, 11 NRC 451, 457 (1980).

<sup>10</sup> "Memorandum and Order Rejecting Late-Filed Contentions from FOE and AWPP, Denying AWPP's Second Request for Reconsideration of Asbestos Contention, Denying AWPP's Motion to Add a PVC Contention and Commenting on an Invalid Inference in Del-Aware's May 17, 1984 Filing," August 24, 1984 (unpublished).

<sup>11</sup> *Three Mile Island*, CLI-85-4, *supra* note 6.

information which warrants a change in the Staff's previous conclusions regarding these matters. Accordingly, the petitioners' requests for action, which have been treated by the Staff pursuant to § 2.206, are denied. As provided in 10 C.F.R. § 2.206(c), a copy of this Decision will be filed with the Secretary for the Commission's review.

Darrell G. Eisenhut, Acting  
Director  
Office of Nuclear Reactor  
Regulation

Dated at Bethesda, Maryland,  
this 21st day of January 1986.

