

VIRGINIA ELECTRIC AND POWER COMPANY
RICHMOND, VIRGINIA 23261

September 4, 1996

U.S. Nuclear Regulatory Commission
Attention: Document Control Desk
Washington, D.C. 20555

Serial No. 96-409
NAPS/GSS/ETS R0
Docket Nos. 50-338
50-339
License Nos. NPF-4
NPF-7

Gentlemen:

VIRGINIA ELECTRIC AND POWER COMPANY
NORTH ANNA POWER STATION UNITS 1 AND 2
PROPOSED TECHNICAL SPECIFICATIONS CHANGE
USE OF LEAD FUEL ASSEMBLIES
WITH ADVANCED CLADDING MATERIAL

Pursuant to 10 CFR 50.12 and 10 CFR 50.90, Virginia Electric and Power Company requests an exemption from certain requirements of 10 CFR 50.44, 10 CFR 50.46, and Appendix K of 10 CFR 50, and changes to the license and Technical Specifications for Facility Operating License Numbers NPF-4 and NPF-7 for North Anna Power Station Units 1 and 2, respectively. The proposed exemptions, license and Technical Specification changes will allow the use of four lead test assemblies fabricated by Framatome Cogema Fuels (FCF). NRC permission is also requested to apply Virginia Electric and Power Company's standard reload design methodology to the North Anna cores in which these four lead test assemblies are irradiated. Previously application of Virginia Electric Power Company's standard reload design methodology was limited for use only with Westinghouse fuel.

Implementation of this Technical Specification change requires an exemption from certain requirements of 10 CFR 50.44, "Standards for combustible gas control system in light-water-cooled power reactors," 10 CFR 50.46, "Acceptance criteria for emergency core cooling systems for light water nuclear power reactors," and Appendix K of 10 CFR 50, "ECCS Evaluation Models." The basis for the exemption from the requirements of 10 CFR 50.44, 10 CFR 50.46 and 10 CFR 50 Appendix K is included in Attachment 1. These lead test assemblies will use two advanced zirconium-based alloys which do not fit the design specifications for either Zircaloy or ZIRLO for the fabrication of the structural tubing (guide thimbles and instrumentation tube) and fuel rod cladding.

A discussion of the proposed Technical Specifications changes, including an evaluation of the safety significance of irradiating the lead test assemblies, is provided in Attachment 2. The proposed Technical Specifications changes are provided in Attachment 3.

9611080111 960904
PDR ADOCK 05000338
P PDR

APD
11

The proposed exemptions and license/Technical Specifications changes have been reviewed and approved by the Station Nuclear Safety and Operating Committee and the Management Safety Review Committee. It has been determined that the proposed exemptions, license and Technical Specifications changes, and the use of the lead test assemblies supported by this change do not involve an unreviewed safety question as defined in 10 CFR 50.59 or a significant hazards consideration as defined in 10 CFR 50.92. The basis for our determination that the changes do not involve a significant hazards consideration is provided in Attachment 4.

The lead test assemblies are currently scheduled to begin operation in North Anna Unit 1 in the spring of 1997. To support the planned operation of these assemblies, we request approval of the proposed license and Technical Specifications changes and issuance of the necessary exemptions by February, 1997.

Attachment 2 contains information that is proprietary to Framatome Cogema Fuels. This is supported by an affidavit (Attachment 5) signed by J. H. Taylor, Manager - Licensing Services, Framatome Cogema Fuels, Inc. This affidavit sets forth the basis on which the information may be withheld from public disclosure by the Commission, and addresses the considerations listed in 10 CFR 2.790. Accordingly, it is requested that Attachment 2 of this letter, which contains information proprietary to FCF, be withheld from public disclosure in accordance with 10 CFR 2.790. In compliance with the guidelines of NUREG-0390, a copy of Attachment 2 in which the proprietary information has been identified is also being provided as Attachment 6.

Should you have any questions or require additional information, please contact us.

Very truly yours,

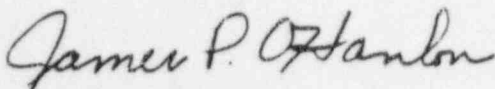

James P. O'Hanlon
Senior Vice President - Nuclear

Attachments

cc: U.S. Nuclear Regulatory Commission
Region II
101 Marietta Street, N.W.
Suite 2900
Atlanta, Georgia 30323

Mr. R. D. McWhorther
NRC Senior Resident Inspector
North Anna Power Station

Commissioner
Department of Radiological Health
Room 104A
1500 East Main Street
Richmond, VA 23219

COMMONWEALTH OF VIRGINIA)
)
COUNTY OF HENRICO)

The foregoing document was acknowledged before me, in and for the County and Commonwealth aforesaid, today by J. P. O'Hanlon, who is Senior Vice President - Nuclear, of Virginia Electric and Power Company. He is duly authorized to execute and file the foregoing document in behalf of that Company, and the statements in the document are true to the best of his knowledge and belief.

Acknowledged before me this 4TH day of September, 1996.

My Commission Expires: May 31, 1998.

Vicki L. Hull
Notary Public

(SEAL)

ATTACHMENT 1

**VIRGINIA ELECTRIC AND POWER COMPANY
BASIS OF EXEMPTION REQUEST**

bc:

- Mr. D. A. Heacock - NAPS (without Attachments 5 and 6)
- Mr. B. L. Shriver - SPS (without Attachments 5 and 6)
- Mr. P. A. Kemp - NAPS (without Attachments 5 and 6)
- Ms. C. G. Lovett - SPS (without Attachments 5 and 6)
- Mr. G. L. Darden - 1N-3SW (letter only)
- Mr. N. P. Wolfhope - 1N-3SW (without Attachments 5 and 6)
- Mr. J. B. Lee - IN2SE (without Attachments 5 and 6)
- Licensing File - GOV 02-54B (without Attachments 5 and 6)
- MSRC Coordinator (without Attachments 5 and 6)
- Records Management - GOV 02-54B (bc original) - IN-GW
- NOB Distribution (without Attachments 5 and 6)

Concurrence:

Mr. J. P. O'Hanlon

Mr. M. R. Kansler

Mr. R. F. Saunders

Mr. M. L. Bowling

Mr. R. M. Berryman

Mr. W. R. Matthews

Mr. D. A. Sommers

MAR 9/3/96

NA

NA for MCB

RMB 8/22/96 DGL 8/29/96

WRM per telcon CSS 9/3/96

NA 8/29/96

Verification of Accuracy:

1. Approved North Anna Technical Specification Change Request No. 337 dated August 28, 1996.

Required Changes to the UFSAR or the Topical Report:

1. Yes, UFSAR Change Request (FN 96-051)

Action Plan/Commitments (Stated or Implied):

1. Corporate Licensing to process UFSAR Change Request, upon issuance of the Technical Specification Amendment.

REGULATORY BASIS FOR SPECIFIC EXEMPTIONS

Virginia Electric and Power Company plans to irradiate four (4) fuel assemblies fabricated by Framatome Cogema Fuels (FCF) at North Anna. Operation of these lead test assemblies is currently scheduled to begin in North Anna 1 Cycle 13, in the second quarter of 1997. These fuel assemblies will be very similar to the FCF Mark-BW fuel assembly design that has previously been irradiated in other Westinghouse-designed reactors. However, the North Anna fuel assemblies will incorporate several new features, including use of two advanced zirconium-based alloys, Alloy 4 and Alloy 5, for the fuel rod cladding. The majority of the fuel rods will have cladding fabricated from Alloy 5, but two of the assemblies will also contain a small number of fuel rods with cladding fabricated from Alloy 4. These two alloys have previously been used as cladding materials for limited numbers of fuel rods in demonstration assemblies in the McGuire Unit 1 and Three Mile Island Unit 1 reactors, as well as in several European reactors. The North Anna lead test assemblies will differ from these demonstration assemblies in using advanced alloys as the cladding materials for all fuel rods in the assemblies.

In support of the proposed irradiation of these lead test assemblies, exemptions are being requested to 10 CFR 50.46 and 10 CFR 50.44, which specifically refer to fuel with Zircaloy or ZIRLO cladding, and Paragraph I.A.5 of Appendix K to 10 CFR Part 50, which requires use of a specific model that was originally derived for Zircaloy clad fuel.

10 CFR 50.12 states that the Commission may grant an exemption from requirements contained in 10 CFR 50 provided that: 1) the exemption is authorized by law, 2) the exemption will not result in an undue risk to the public health and safety, 3) the exemption is consistent with the common defense and security, and 4) special circumstances, as defined in 10 CFR 50.12(a)(2), are present. The requested exemptions to allow the use of advanced zirconium based alloys other than Zircaloy or ZIRLO for the fuel cladding material in four lead test assemblies to be supplied to North Anna Power Station by Framatome Cogema Fuels satisfy these requirements as described below.

1. The requested exemption is authorized by law.

Lead test assembly programs and irradiation of new materials are not precluded by any law. The FCF lead test assemblies to be irradiated at North Anna incorporate cladding materials which do not conform to the cladding material designations explicitly defined in 10 CFR 50.44 and 10 CFR 50.46 (i.e., Zircaloy or ZIRLO). However, the criteria of these sections will continue to be satisfied for North Anna cores incorporating these fuel assemblies. Similarly, Appendix K of 10 CFR 50 requires use of the Baker-Just equation, which was developed for use with Zircaloy clad fuel. Although the lead test assemblies at North Anna will use different zirconium-based alloys for the fuel rod cladding, the Baker-Just equation was determined to be appropriate for evaluation of these materials, and was applied to the loss of coolant accident (LOCA) analyses of the lead test assemblies. Therefore, issuance of exemptions to allow the use of cladding materials other than Zircaloy or ZIRLO in the North Anna lead test assemblies will not result in the violation of the criteria of the applicable sections of 10 CFR 50.

2. The requested exemption does not present an undue risk to the public health and safety.

The safety evaluation for the use of the lead test assemblies demonstrated that the margin of safety as defined in the Bases to any North Anna Technical Specification is not reduced. Use of the lead test assemblies will not increase the probability of occurrence or the consequences of an accident at the North Anna Power Station, and will not create the possibility for a new or different type of accident which could pose a risk to public health and safety. Safety analyses which are based on full cores of Westinghouse fuel and which are supported by the applicable North Anna Unit 1 and North Anna Unit 2 Technical Specifications will remain applicable for cores incorporating the lead test assemblies.

For each applicable reload cycle, the lead test assemblies will be specifically evaluated using Virginia Electric and Power Company's standard reload design methods. This will include consideration of the core physics analysis peaking factors and core average linear heat rate effects. Cores incorporating the lead test assemblies will be operated in accordance with the operating conditions identified in the Technical Specifications. In the unlikely event that cladding failures occur in the lead test assemblies during normal operation of the core, the environmental impact will be minimal and bounded by previous environmental assessments.

3. The requested exemption will not endanger the common defense and security.

The lead test assemblies are similar to normal reload fuel assemblies, and the special nuclear material used in these assemblies will be procured, handled and controlled in accordance with approved procedures. Use of the four FCF lead test assemblies will not affect the operation of the North Anna Power Station or endanger the common defense and security.

4. Special circumstances are present which necessitate the request for an exemption to the regulations of 10 CFR 50.44, 10 CFR 50.46, and Paragraph L.A.5 of Appendix K to 10 CFR 50.

Pursuant to 10 CFR 50.12(a)(2), the NRC will not consider granting an exemption to the regulations unless special circumstances are present. The requested exemptions meet the special circumstances of paragraph (a)(2)(ii), in that application of these regulations in this particular circumstance is not necessary to achieve the underlying purpose of the regulations.

- The underlying purpose of 10 CFR 50.46 is to ensure that nuclear power facilities have adequate acceptance criteria for their ECCS. The effectiveness of the ECCS at North Anna Units 1 and 2 will not be affected by the insertion of the four lead test assemblies. Although these assemblies incorporate cladding materials other than those explicitly defined in 10 CFR 50.46, the criteria of this section will continue to be satisfied for North Anna cores incorporating the lead test assemblies. Safety analyses based on the resident fuel design will remain applicable for cores which incorporate the lead test assemblies. Thus use of the advanced zirconium-based cladding materials will not have a detrimental impact on the performance of the North Anna cores under LOCA conditions.

- The intent of 10 CFR 50.44 is to ensure that there is an adequate means of controlling the hydrogen generated following a LOCA. The post-LOCA hydrogen source which is relevant to the lead test assemblies is the metal-water reaction between the fuel rod cladding and the reactor coolant. The Baker-Just equation has been confirmed to conservatively assess the metal-water reaction rate for the advanced zirconium-based alloys. Therefore, the amount of hydrogen generated by metal-water reaction in these materials will be within the design basis for the North Anna units.
- The intent of Paragraph I.A.5 of Appendix K of 10 CFR Part 50 is to apply an equation for rates of energy release, hydrogen generation, and cladding oxidation from a metal-water reaction that conservatively bounds all post-LOCA scenarios. Application of the Baker-Just correlation will continue to conservatively bound all post-LOCA scenarios for the use of the lead test assemblies due to the similarities between the compositions of the advanced zirconium-based alloys and Zircaloy-4.

Therefore, the intent of 10 CFR 50.46, 10 CFR 50.44, and 10 CFR Part 50, Appendix K, will continue to be satisfied for the planned operation of the lead test assemblies. Issuance of a temporary exemption from the criteria of these regulations for the irradiation of these four assemblies in the North Anna reactors will not compromise the safe operation of the reactors.

ATTACHMENT 2

VIRGINIA ELECTRIC AND POWER COMPANY

**DISCUSSION OF PROPOSED
TECHNICAL SPECIFICATION CHANGES**

NORTH ANNA UNITS 1 AND 2

DISCUSSION OF CHANGES

INTRODUCTION

Virginia Electric and Power Company plans to insert four (4) fuel assemblies fabricated by Framatome Cogema Fuels (FCF) into the North Anna 1 Cycle 13 core, currently scheduled to begin operation in the second quarter of 1997. These fuel assemblies will be very similar to the FCF Mark-BW fuel assembly design which has previously been irradiated in other Westinghouse-designed reactors. [

Although the lead test assembly program is currently planned for implementation only in North Anna Unit 1, Virginia Electric and Power Company is requesting NRC approval to irradiate the lead assemblies in either North Anna Unit 1 or North Anna Unit 2 to maximize program flexibility. Based on evaluations and analyses, no unreviewed safety questions exist as a result of inserting the advanced cladding materials or fuel assemblies of the FCF design into the North Anna Units 1 and 2 reactor cores. However, the Technical Specifications for both North Anna Unit 1 and North Anna Unit 2 define the fuel rod cladding material as either Zircaloy-4 or ZIRLO. Use of a different cladding material in the lead test assemblies therefore requires changes to the Technical Specifications and a license condition to permit use of the lead test assemblies. Exemptions are also required to 10 CFR 50.46 and 10 CFR 50.44, which specifically refer to fuel with Zircaloy or ZIRLO cladding, and Appendix K of 10 CFR Part 50, which requires use of a specific model originally derived for Zircaloy clad fuel. In addition, the Safety Evaluation report for our standard reload nuclear design methodology (VEP-FRD-42 Rev. 1-A) specified that, in its present form, our methodology was approved only for application to Westinghouse-supplied fuel in Westinghouse-supplied reactors. Therefore NRC concurrence is also required to apply Virginia Electric and Power Company's standard reload design methodology to cores containing these lead test assemblies.

LEAD TEST ASSEMBLY PROGRAM

Framatome began an advanced alloy program in 1987 to develop fuel rod cladding and structural tube materials for high burnup application. This program has involved extensive testing of several candidate alloys, with two alloys being selected for further characterization on the basis of their superior performance in both in-core and out of core testing. Demonstration assemblies which included both alloys have been irradiated in three European reactors as well as in Duke Power

Company's McGuire Unit 1. Irradiation of these advanced alloys is continuing in additional European reactors and in Three Mile Island Unit 1 in the United States.

Framatome Cogema Fuels (FCF) and the Virginia Electric and Power Company have entered into an agreement to irradiate four (4) lead test assemblies with advanced FCF fuel design features. This program is expected to provide additional information on the behavior of the FCF advanced cladding materials under commercial operating conditions to a lead rod burnup of approximately 55 to 60 GWD/MTU in three 18-month operating cycles, as well as to demonstrate the performance of the FCF fuel assembly advanced mechanical design features under in-reactor conditions. Use of the four lead test assemblies is currently planned to begin at North Anna Unit 1 starting with Cycle 13, which is currently scheduled for late spring, 1997.

Post irradiation examinations of the lead test assemblies will be performed during the lead test assembly program as permitted by the North Anna refueling schedule. In addition to visual examinations, these examinations may include: measurement of fuel assembly length and bow, holddown spring compression testing, functional testing of the quick disconnect locking mechanism, oxide measurements on fuel rods and guide thimbles, and measurements of fuel rod diameter and length. Depending on the outcome of the current Westinghouse Owners Group evaluation of control rod insertion in high burnup fuel assemblies, control rod drag testing may also be desirable once the lead test assemblies reach high burnups.

The current fuel in North Anna Units 1 and 2 is the North Anna Improved Fuel (NAIF) design, which is a Westinghouse 17x17 VANTAGE-5H design, into which additional debris resistance features and ZIRLO fuel rod cladding and skeleton components have subsequently been incorporated. Descriptions of the fuel design can be found in our submittals to the NRC for the implementation of the NAIF design, dated January 15, 1990 (Reference 1), and for the implementation of ZIRLO, dated October 4, 1993 (Reference 2).

The North Anna lead test assemblies will be mechanically similar to, and fully compatible with, the resident Westinghouse fuel assemblies. The primary differences between the resident Westinghouse fuel design and the FCF the lead test assemblies include the use of the different zirconium-based alloys for fuel rod cladding and fuel assembly structural tubing, incorporation of the mid-span mixing grids into the lead test assemblies, and use of a higher nominal fuel pellet density in the lead test assemblies, which will result in a higher uranium loading than in the Westinghouse fuel design. Incorporation of the quick release top nozzle design, the use of the fine mesh debris filter bottom nozzle, and the use of FCF's axially 'floating' grid design (versus the more rigid attachment of the Westinghouse grids) are not expected to affect the compatibility of the lead test assemblies with the resident fuel.

The areas assessed during the safety evaluation process included: chemical/mechanical properties, neutronic performance, thermal and hydraulic performance, cladding performance under non-LOCA conditions, and cladding performance under LOCA conditions. These evaluations and analyses have shown that the present safety related design bases and calculations are applicable for North Anna cores which incorporate the lead test assemblies.

The use of the FCF lead test assemblies does not alter the models and methods used for analyzing cycle specific reloads of North Anna fuel (References 3 and 4). Analyses and evaluations performed by Virginia Electric and Power Company, Framatome Cogema Fuels (FCF), and Framatome Technologies Inc. (FTI, the division of Framatome which performed the LOCA analyses) to support this conclusion are described in the attached Safety Significance evaluation. Plant and cycle specific evaluations and analyses will continue to be performed for North Anna Units 1 and 2 core designs to demonstrate that the current design bases and limits remain valid for cores containing the lead test assemblies.

LICENSE CONDITIONS AND TECHNICAL SPECIFICATIONS CHANGES

General

Although the FCF lead test assembly program is currently planned for implementation in North Anna Unit 1, Virginia Electric and Power Company is requesting NRC approval to irradiate the lead assemblies in either North Anna Unit 1 or North Anna Unit 2. This flexibility will support a more timely completion of the program if, for example, after 1 or 2 cycles of irradiation a more extensive characterization of the assemblies is desired than could be supported by the North Anna 1 refueling schedule. In such a case, the program could then be expedited by reinserting the lead test assemblies into Unit 2 after the testing is completed, rather than waiting until the next North Anna 1 refueling outage. The license and Technical Specification changes described herein therefore apply to both North Anna Unit 1 and North Anna Unit 2.

License Conditions

License conditions are being requested to permit use of the FCF lead test assemblies in North Anna Units 1 and 2. These license conditions will permit the use of up to four (4) assemblies with the advanced zirconium based alloys. The following license conditions are being proposed for both Unit 1 and Unit 2.

"Virginia Electric and Power Company may use up to four (4) fuel assemblies containing advanced zirconium based alloys as described in the licensee's submittal dated September 4, 1996."

For North Anna Unit 1, the proposed license condition replaces existing licensing condition 2.D.3.(d). For North Anna Unit 2, a new license condition, 2.C.(24), is being created.

Technical Specification 5.3.1

The Design Features section on the Fuel Assemblies (Technical Specification 5.3.1) will be changed to allow use of fuel rods with slightly different nominal dimensions or rods clad with materials other than Zircaloy-4 or ZIRLO with an approved exemption or license condition. This change acknowledges that fuel assemblies, such as those specifically approved for use as lead test

assemblies, may sometimes be irradiated that have slightly different features than the resident fuel (e.g., the Alloy 4 and Alloy 5 fuel rod cladding in the FCF lead test assemblies).

Technical Specification 6.9.1.7.b

Thorough evaluation of the performance of fuel that has features different from the resident fuel assemblies may require the use of NRC-approved models and methods beyond those normally used to evaluate North Anna fuel. An example of this is the use of the Framatome Technologies Inc. (FTI) NRC-approved models to perform the LOCA evaluation of lead test assemblies with Alloy 4 and Alloy 5 fuel rod cladding. Therefore, the identification of applicable references for the methods used to determine the North Anna core operating limits (Technical Specification 6.9.1.7.b) is being modified to note that such additional approved methods may be used with an approved exemption or license condition. The specific applicable models and methods will be identified in the documentation supporting the request for the exemption or license condition.

REQUEST FOR EXEMPTIONS

Title 10 CFR 50.46(a)(1)(i) states,

"Each boiling and pressurized light-water nuclear power reactor fueled with uranium oxide pellets within cylindrical zircaloy or ZIRLO cladding must be provided with an emergency core cooling system (ECCS) that must be designed so that its calculated cooling performance following postulated loss-of-coolant accidents conforms to the criteria set forth in paragraph (b) of this section. ECCS cooling performance must be calculated in accordance with an acceptable evaluation model and must be calculated for a number of postulated loss-of-coolant accidents of different sizes, locations, and other properties sufficient to provide assurance that the most severe postulated loss-of-coolant accidents are calculated." Section 10 CFR 50.46 goes on to delineate specifications for peak cladding temperature, maximum cladding oxidation maximum hydrogen generation, coolable geometry, and long-term cooling.

In addition, 10 CFR 50.44 (a) states,

"Each boiling or pressurized light-water nuclear power reactor fueled with oxide pellets with cylindrical zircaloy or ZIRLO cladding, must, as provided in paragraphs (b) through (d) of this section, include means for control of hydrogen gas that may be generated, following a postulated loss-of-coolant accident (LOCA)..."

Since 10 CFR 50.46 and 10 CFR 50.44 specifically refer to fuel with Zircaloy or ZIRLO clad, the use of fuel clad with zirconium-based alloys that do not conform to either of these two designations in the North Anna lead test assemblies requires an exemption from these sections of 10 CFR 50.

Further, 10 CFR Part 50, Appendix K, paragraph I.A.5 states,

"The rate of energy release, hydrogen generation, and cladding oxidation from the metal water reaction shall be calculated using the Baker-Just equation."

Since the Baker-Just equation was originally developed for the use of Zircaloy cladding, the use of fuel with the advanced zirconium-based alloys also requires an exemption from this section of the code.

The FCF lead test assemblies to be irradiated at North Anna will use fuel rod cladding fabricated from two advanced zirconium-based alloys, which do not meet the definition of Zircaloy or ZIRLO. As a result, a temporary exemption to 10 CFR 50.46, 10 CFR 50.44, and 10 CFR Part 50, Appendix K, is required for the irradiation of these four lead test assemblies. A safety evaluation has been performed to demonstrate that the intent of these regulations are satisfied for the lead test assemblies and to confirm that no unreviewed safety question exists. Specifically:

- The underlying intent of 10 CFR 50.46 is to ensure that nuclear power facilities have adequate acceptance criteria for their ECCS. The effectiveness of the ECCS at North Anna Units 1 and 2 will not be affected by the insertion of the four lead test assemblies. Due to similarities in materials properties of the two advanced zirconium-based alloys to Zircaloy-4, the ECCS performance in the North Anna reactors will not be adversely affected by the presence of the lead test assemblies. Thus use of the advanced zirconium-based cladding materials will not have a detrimental impact on the performance of the North Anna cores under LOCA conditions.
- The intent of 10 CFR 50.44 is to ensure that there is an adequate means of controlling generated hydrogen. The post-LOCA hydrogen source which is relevant to the lead test assemblies is the metal-water reaction between the fuel rod cladding and the reactor coolant. The Baker-Just equation, which is used to assess the metal-water reaction rate for Zircaloy-4, has been confirmed to conservatively assess the metal-water reaction rate for the advanced zirconium-based alloys as well. Therefore, the amount of hydrogen generated by metal-water reaction in these materials will be within the design basis for the North Anna units, and existing plant specific analyses for the total hydrogen generation following a LOCA will remain applicable for use of the lead test assemblies.
- The intent of Paragraph I.A.5 of Appendix K of 10 CFR Part 50 is to apply an equation for rates of energy release, hydrogen generation, and cladding oxidation from a metal-water reaction that conservatively bounds all post-LOCA scenarios. Application of the Baker-Just correlation will continue to conservatively bound all post-LOCA scenarios for the use of the lead test assemblies due to the similarities between the compositions of the advanced zirconium-based alloys and Zircaloy-4.

Therefore, the intent of 10 CFR 50.46, 10 CFR 50.44, and 10 CFR Part 50, Appendix K, will

continue to be satisfied for the planned operation of the lead test assemblies. Issuance of a temporary exemption from the criteria of these regulations for the irradiation of these four assemblies in the North Anna reactors will not compromise the safe operation of the reactors.

Finally, the NRC Safety Evaluation Report (SER) which approved Virginia Electric and Power Company's reload nuclear design methodology (VEP-FRD-42 Rev. 1-A) concluded that the report is "...acceptable for referencing by Virginia Power in licensing Westinghouse supplied reloads of Westinghouse supplied reactors." Since these lead test assemblies will be supplied by Framatome Cogema Fuels, NRC permission is requested to apply the Virginia Electric and Power Company standard reload design methodology to North Anna cores containing the four lead test assemblies. As documented in the attached Safety Significance evaluation, use of the lead test fuel assemblies in the North Anna cores has been thoroughly evaluated and will have no discernible impact on the overall core performance. Incorporation of these assemblies into North Anna cores will not affect the ability of the reload methodology to predict the core performance or to conservatively assess the core response to accident scenarios.

SAFETY SIGNIFICANCE SUMMARY

The FCF lead test assemblies are mechanically and neutronically very similar in design to the Westinghouse fuel that comprises the remainder of the core. The reload core design for North Anna cycles which incorporate the lead test assemblies will meet all applicable design criteria, and will not result in any changes to the North Anna Units 1 and 2 operating and safety analysis limits. The existing safety analyses based on the resident Westinghouse fuel design will remain applicable for cores incorporating the FCF lead test assemblies. Analyses or evaluations will be performed each cycle to confirm that the criteria in 10 CFR 50.46 will be met. Use of the FCF lead test assemblies will not result in an unreviewed safety question as defined in 10 CFR 50.59, and will not constitute a significant hazards consideration as defined in 10 CFR 50.92.

TECHNICAL AND SAFETY EVALUATION

1. Lead Test Assembly Design Description

The lead test assemblies to be irradiated at North Anna are very similar to the Mark-BW fuel assemblies that have been supplied by Framatome Cogema Fuels (FCF) to five other Westinghouse-designed operating units. The Mark-BW design, which is described in detail in Reference 5, is a 17x17 standard lattice, Zircaloy spacer grid fuel assembly designed specifically for use in Westinghouse units.

The lead test assemblies for North Anna, which are designated the Mark-BW17 design (Figure 1.1), also incorporate several advanced components and features, as described below.

1.1 Quick Disconnect Top Nozzle

The Mark-BW17 fuel assembly design incorporates a reconstitutable, quick disconnect top nozzle assembly. The quick disconnect feature provides easy removal and reattachment of the top nozzle with no loose parts. The design features a double-spline sleeve attached to the guide thimble and a locking ring which is contained within the top nozzle. Rotation of this ring by 90° using reconstitution tooling allows the sleeve splines to be locked or unlocked.

The Mark-BW17 top nozzle also incorporates two additional changes from the standard FCF top nozzle design. On the Mark-BW design, fuel assembly lift during operation is precluded by four sets of 3-leaf springs made of [] which are fastened to the nozzle with [] clamp screws. []

[] The top nozzle plate also incorporates a modified flow hole pattern. This flow hole pattern provides an increased flow area, and thus a lower pressure drop, compared to the traditional FCF design, while satisfying the same strength requirements.

1.2 [] Guide Thimble Tubing

The guide thimbles and instrument tube are dimensionally identical for the Mark-BW and Mark-BW17 designs. However, the Mark-BW fuel design uses guide thimbles and an instrument tube fabricated from [] while in the Mark-BW17 design these components are fabricated from [] The composition of this material and its physical properties are discussed in more detail in Section 2 of this assessment.

The guide thimbles have a relatively large diameter at the top to permit rapid insertion of the rod cluster control assembly (RCCA) during a reactor trip, and a reduced diameter at the lower end of the tube (the dashpot) to decelerate the control rods near the end of the control rod travel. The diameters of the Mark-BW17 fuel assembly guide thimbles are comparable to those found on older Westinghouse fuel assemblies used at North Anna (i.e., 17x17 LOPAR assemblies, with Inconel

mid-grids). The Mark-BW17 guide thimbles have four small holes located just above the dashpot to allow outflow of the water during RCCA insertion. These holes are identical to those on the guide thimbles of the Mark-BW fuel design.

The stainless steel quick disconnect sleeve is attached to the upper end of the Mark-BW17 guide thimble by a mechanical swage for connection to the top nozzle. As on the Mark-BW design, a Zircaloy-4 lower end plug is welded onto the end of the guide thimble dashpot section. This lower end plug is internally threaded for engagement with the guide thimble bolt, which connects the guide thimble to the bottom nozzle.

The instrumentation tube diameters are comparable to those on the 17x17 LOPAR Westinghouse fuel assemblies used at North Anna, which helps ensure compatibility of the lead test assemblies with the in-core instrumentation.

1.3 Spacer Grids

The Mark-BW17 fuel assembly design incorporates a total of 11 grids. As shown in Figure 1.1, these include (from the bottom of the assembly to the top): an Inconel bottom end grid, one vaneless Zircaloy-4 intermediate grid, five vaned Zircaloy-4 intermediate grids, three Zircaloy-4 mid-span mixing grids located between the top four vaned intermediate grids, and an Inconel top end grid.

1.3.1 Intermediate Grids

The Mark-BW17 intermediate spacer grids are fabricated of Zircaloy-4. These grids are identical to those used on the Mark-BW design with the exception of a small modification to the vane pattern. The grids are fabricated from strips of Zircaloy-4 which are assembled in an "egg crate" fashion. A laser weld is performed at each strip intersection with the outer face of the grid to secure the strips. The inner strip end tabs are also laser (bead) welded. A combination of springs and dimples act in two orthogonal planes to support each fuel rod. The standard FCF keyable features are maintained for the Mark-BW17 intermediate grids to allow scratch free and stress free fuel rod insertion during fuel assembly fabrication.

As in the Mark-BW fuel design, two types of intermediate spacer grids are being used on the lead test assemblies: vaned and vaneless (see Figure 3.1). The five intermediate grids in the high heat flux region of the fuel assembly incorporate vanes to promote mixing of the coolant.

To minimize the overall fuel assembly pressure drop, the first intermediate spacer grid (i.e., the Zircaloy grid closest to the bottom of the fuel assembly) does not incorporate mixing vanes. With the exception of the lack of mixing vanes, this grid is identical in design to the intermediate vaned grids. The resident Westinghouse fuel designs have a mixing vane grid at this location.

Another Mark-BW fuel assembly design is incorporated into the lead test assemblies, where the intermediate spacer grids on the Mark-BW17 design are allowed to move axially upward, following the movement of the fuel rods as they grow due to irradiation, until burnup effects have significantly relaxed the Zircaloy spacer grids. Restraining ferrules, which are short sleeves made of Zircaloy, are attached to eight selected guide thimbles above each intermediate grid to limit the amount of axial movement. A ferrule is also attached to the instrument tube below the top end spacer grid and below the intermediate spacer grids to prevent downward motion of the grids. The distance that the ferrules permit the grids to move increases slightly with elevation. Figure 1.2 illustrates the primary features of this grid restraint system, and identifies the guide thimble locations that are used to restrain grid movement. This floating grid system minimizes both slip loads in the fuel assembly and stresses in the fuel rods.

1.3.2 End Grids

The end spacer grids on the Mark-BW17 fuel design are fabricated from Inconel-718, and are identical to the Inconel end spacer grids on the Mark-BW design. Short stainless steel sleeves are attached to weld tabs on the guide thimble locations of these grids. On the upper end grids, these tabs are on the top of the grid strips, while on the lower end grids these tabs are on the bottom of the grid strips. The Mark-BW17 end grids, like the intermediate grids, incorporate keying windows, to allow deflection of the soft stop springs during fuel rod insertion. This standard FCF feature minimizes fuel rod scratches, cell hardstop and softstop damage, and fuel assembly residual stresses.

As on the Mark-BW fuel assembly, the bottom end grids on the lead test assemblies are connected to the guide thimbles by mechanically crimping the stainless steel sleeves into grooves in the guide thimble bottom end plugs. This attachment prevents axial motion of the bottom grids.

Two top end grid restraint designs are being used on the lead test assemblies. Two of the assemblies will use the same type of restraint as the Mark-BW design, with the top end grid sleeves seated against the bottom surface of the quick disconnect sleeve. This design prevents axial movement of the top end grid. The second design, to be used on the remaining two lead test assemblies, is a floating top end grid design. In this case, slightly shorter top end grid sleeves are used, allowing a small gap [] to exist between the top of the sleeves and the bottom of the quick disconnect sleeve at beginning of life. With this design, as the fuel rods grow (due to irradiation) the top end grid moves upward with the fuel rods until the top grid sleeves contact the quick disconnect sleeves. By the time the top end grid is in contact with the sleeves, burnup effects will have significantly relaxed the force exerted on the fuel rods by the top end grid. The floating top end grid design has been shown to result in reduced fuel assembly growth.



Incorporation of the two top end grid restraint designs into the North Anna lead test assemblies will permit quantification of the relative contributions of the advanced alloy and the restraint design to the overall reduction in assembly growth.

1.3.3 Handling Interfaces

From the perspective of handling interfaces, both the intermediate and end grid designs on the lead test assemblies are identical to those on the Mark-BW fuel design. The outer grid straps have generous lead-in vanes that aid in guiding the grids and fuel assemblies past projecting surfaces, to facilitate core onload and offload. These lead-in vanes are strengthened by welding them to the inner strip. The grid outer straps also have press-formed stiffening dimples that provide added strength to resist tearing. The recess of the stiffening dimple is also used as a weld land for the inner and outer strip connection, eliminating any exposed edges. The outer strap corner joint is a welded, lapped joint which is carefully dressed to remove weld buildup and minimize distortion. The outer grid corner also incorporates a structural support column to increase corner strength. The grid corner strength is designed to exceed normal handling equipment limits by more than [] In more than 900 handling opportunities, not one Mark-BW fuel assembly incorporating these features has sustained handling damage requiring either discharge or refurbishment.

1.4 Mid-Span Mixing Grids

To provide additional flow mixing in the high heat flux region of the fuel assembly, each lead test assembly includes three mid-span mixing grids (MSMGs), located mid-way between the upper four intermediate vaned grids (Figure 1.1). These grids are constructed from [] strips which are assembled and welded in a manner similar to the Zircaloy-4 intermediate grids. The MSMGs use the same mixing vane pattern as the Mark-BW17 intermediate vaned grid. [] very slight difference in the vane profile, as shown in Figure 1.3, but this has a negligible impact on []

[] Stops formed in each of the four cell walls prevent the fuel rods from contacting the mixing vanes without imposing a grip force (or slip load) on the rods. Therefore, the MSMGs are designated as non-contacting grids.

The outer strip design of the MSMG includes a large lead-in feature to preclude grid hangup or damage during handling. A wrap-around corner design is also used to improve the handling interfaces. []

[] do not have grids at the MSMG elevations.)

[] (The resident Westinghouse fuel assemblies

The MSMGs are attached to the corner guide thimble locations (Figure 1.2). Because these are non-contacting grids (i.e., they exert no load on the fuel rods), the MSMGs are rigidly attached to the guide thimble. Axial movement is precluded by welding grid sleeves (ferrules) to the top of the MSMG strips at the corner guide thimble locations, and then dimpling these sleeves to the guide thimbles in a manner similar to that used to attach the restraining ferrules for the intermediate grids. To help distribute the hydraulic loads, the MSMGs are attached to different guide thimbles than the floating intermediate grids.

1.5 Advanced Debris Filter Bottom Nozzle

The Mark-BW17 fuel design incorporates a debris filter bottom nozzle consisting of a fine mesh filter plate supported by a structural frame. The structural frame consists of deep ribs of type 304 stainless steel which connect the guide thimble locations, and which are attached to conventional legs that interface with the reactor internals.

The filter plate is attached to the top of the structural frame prior to skeleton fabrication by pins welded to the nozzle at the four corners. Upon skeleton assembly, the guide thimble bolts extending through the bottom nozzle into the guide thimble lower end plugs also clamp the filter plate to the bottom nozzle structural frame at each guide thimble location.

A similar bottom nozzle (with a coarser mesh) has been incorporated into FCF Mark-BW fuel assemblies supplied to Duke Power's McGuire and Catawba units since February, 1996.

1.6 Fuel Rod

The fuel rod design for the North Anna lead test assemblies is very similar to the fuel rods in both the resident Westinghouse fuel and the FCF Mark-BW fuel design. The primary difference is the use of two advanced zirconium-based alloys, Alloy 4 and Alloy 5, as cladding materials. In two of the lead test assemblies, [] fuel rods will have cladding fabricated from Alloy 4. These Alloy 4-clad rods will be uniformly distributed around the periphery of the two fuel assemblies, as shown in Figure 1.6. The cladding for the remainder of the rods in these assemblies will be fabricated from Alloy 5. In the other two lead test assemblies, all of the fuel rods will be fabricated with Alloy 5 cladding. A schematic of the fuel rod design is shown in Figure 1.7, and the composition and properties of the advanced alloys are discussed in more detail in Section 2. Except for the use of different cladding materials, the Alloy 4 and Alloy 5 fuel rod designs are identical.

Each fuel rod consists of a [] stack of UO_2 pellets contained in a seamless Alloy 4 or Alloy 5 tube, with Zircaloy endcaps welded at each end. A stainless steel spring is located in the upper plenum of the fuel rod to prevent the formation of fuel stack gaps during shipping and handling, while also allowing for the expansion of the fuel stack during operation. The fuel stack rests on the lower end cap. By comparison, the Mark-BW fuel rod design has a two spring system, where one spring resides in the plenum above the fuel stack and the second spring resides in a plenum space below the fuel stack. The spring system design for the fuel rods in the Mark-BW17 lead test assemblies is similar to that of the resident North Anna fuel. The fuel rod upper end cap has a grippable "top hat" shape that allows for the removal of the fuel rods from the fuel assembly if necessary. The upper end cap also has a laser-drilled hole which permits evacuation of the fuel rod and backfilling with helium gas. The lower end cap has a bullet-nosed shape for reduced hydraulic resistance, that also facilitates reinsertion of the rods into the assembly if any rods are removed after the assemblies have been irradiated (e.g., during fuel examination programs).

The fuel pellets are a sintered ceramic, high density UO_2 . Each pellet is cylindrically shaped with a spherical dish at each end. The corners of the pellets have an outward land taper (chamfer) that eases the loading of the pellet into the cladding. The dish and taper geometry also reduce the tendency for the pellets to assume an "hourglass" shape during irradiation. The design density of the pellet is 96% theoretical density (TD), which is the same as for the Mark-BW fuel but slightly higher than the nominal density of the UO_2 in the resident Westinghouse fuel rods. The fuel pellets are [] in diameter. The fuel rod cladding has a [] outer diameter, with a [] This configuration leaves a small clearance between the inside diameter of the cladding and the outside diameter of the fuel pellets. The fuel rods in the lead test assemblies use a larger pellet diameter and thinner cladding thickness than used on the Mark-BW fuel rod. However, the clearance between the pellet and the cladding is the same for both designs. The fuel stack length, pellet diameter, cladding diameter and cladding wall thickness for the lead test assembly fuel rods are comparable to the dimensions of the resident Westinghouse fuel. The nominal enrichment of the fuel in the lead test assemblies, 4.2 w/o U-235, is also typical of reload fuel assemblies for North Anna.

2. Advanced Materials

Numerous components of the North Anna lead test assemblies are fabricated from standard materials used for FCF 17x17 Mark-BW fuel assemblies. These materials include: fully recrystallized low-tin Zircaloy-4 (intermediate spacer grids, mid-span mixing grids, fuel rod end caps and guide thimble end plugs, and guide thimble ferrules), Inconel-718 (end grids, holddown spring leaves, holddown spring clamp screws, and quick disconnect locking ring), and austenitic stainless steel alloys (top and bottom nozzles, quick disconnect sleeves, end grid guide thimble sleeves, bottom nozzle filter plate, guide thimble bolts and fuel rod plenum springs).

The guide thimble tubes, instrument tube, and fuel rod cladding are fabricated from two alloys that were developed for high burn-up, low corrosion, and low growth applications.

Table 2.1 compares the compositions of these alloys with the nominal compositions of Zircaloy-4 and ZIRLO, which have been used for fuel rod and structural tubing in North Anna's resident Westinghouse fuel assemblies. The mechanical properties of recrystallized Alloy-4 and Alloy 5, at room temperature and at various elevated temperatures, are summarized in Table 2.2. The appropriate specification limits and comparable data are also provided for FCF Zircaloy-4 for comparison. The limits shown for Zircaloy-4 apply to both fuel rod cladding and structural tubing.

Alloy 4 and Alloy 5 have both been used as cladding materials for limited numbers of fuel rods in demonstration assemblies in several European reactors, as well as at McGuire Unit 1 and Three Mile Island Unit 1 in the United States. Table 2.3 summarizes the in-reactor irradiation experience for these alloys.

The Alloy 4 material irradiated to date has all had the same nominal chemical composition and heat treatment. The nominal composition of Alloy 5 has remained unchanged, but there has been an annealing processes

During tubing fabrication, the alloy undergoes

The initial Alloy 5 tubing material, designated as "5R" in Table 2.3, was fabricated using temperatures and a lower temperature for the final anneal.

No differences in the

The irradiation data to date,

have shown that the uniform corrosion rate and irradiation growth for both Alloy 5 and Alloy 4 are approximately the corresponding rates for low tin Zircaloy-4. Hot cell examinations have shown that Alloy 5 has a hydrogen pickup fraction which is that of Zircaloy-4. The Alloy 4 hydrogen pickup fraction is than Zircaloy-4. However, because Alloy 4 has than in Zircaloy-4, hydrogen accumulation in the Alloy 4 cladding is than in Zircaloy-4.

3. Mechanical Design Evaluations

The mechanical design of the lead test assemblies is supported by test programs, evaluations and analyses. The following discussions summarize the test programs that have been conducted and describe the analyses performed by FCF to support use of the lead test assembly design at North Anna. The impact of the advanced design features, such as the mid-span mixing grids and the use of advanced alloys, on the mechanical design of the assemblies is incorporated into these evaluations. The physical compatibility of the FCF lead test assemblies with North Anna's resident Westinghouse fuel and core internals is also addressed.

3.1 Test Programs

Two comprehensive test programs have been conducted by FCF which support the North Anna lead test assembly design (i.e., the Mark-BW17 design).

3.1.1 Mark-BW Prototype Testing

The first test program was conducted on a prototype Mark-BW fuel assembly, which incorporates several features also found on the Mark-BW17 design. This prototype was fabricated using spacer grids that had been sized to simulate end of life (EOL) conditions. The assembly was then subjected to a series of thermal and hydraulic, environmental, and mechanical characterization tests. The assembly was hydraulically characterized by pressure drop and spacer grid laser Doppler velocimeter (LDV) tests. The environmental, or "life and wear", tests consisted of exposing the fuel assembly to representative reactor temperature, pressure and flow conditions for two 500 hour periods. The fuel assembly exhibited no significant corrosion or unusual wear. Control rod trip testing was also performed utilizing a simulated Westinghouse-type control rod drive mechanism to determine the control rod drop times. Subsequent in reactor testing and operation have confirmed the Mark-BW fuel assembly operational performance.

The mechanical and structural characterization testing on the Mark-BW prototype included assembly frequency and damping tests, assembly axial and lateral stiffness testing, spacer grid stiffness and strength tests, guide tube buckling tests, and force-deflection testing of miscellaneous components. Additionally, the prototype assembly was exercised in handling and storage equipment at Duke

Power's Catawba Nuclear Station, Unit 2, demonstrating compatibility with critical interfaces of a Westinghouse-designed reactor. This exercise included functional tests with both a control rod assembly and a thimble plug assembly. Much of the information obtained from these tests is considered applicable to the Mark-BW17 design since the spacer grid and guide thimble designs are the same, and the ferruled or "floating" grid structure is also employed. The structural and functional testing on this prototype has been verified by successful in reactor operation of 15 batches (1096 fuel assemblies) of Mark-BW fuel.

3.1.2 X1 Prototype Testing

For the second test program (the X1 program), two additional fuel assembly prototypes with mid-span mixing grids (MSMGs) were fabricated to be used in mechanical and thermal hydraulic testing. The mechanical prototype was fully instrumented with strain gages and displacement sensors, and featured the advanced "quick disconnect" top nozzle connection. The tests performed on this assembly included a static axial compression test, static lateral bending tests, shaker tests from which natural frequencies and mode shapes are determined, lateral pluck tests with and without impacts, axial drop tests from various heights, and an axial tension test. The results of the X1 prototype mechanical tests confirmed the applicability of the licensed Mark-BW models (Reference 5) to the Mark-BW17 design being used for the North Anna lead test assemblies.

The thermal hydraulic prototype for the X1 program utilized the fine mesh debris filter bottom nozzle, and had select spacer grid cells sized to EOL conditions. The EOL cell sizes were conservatively established based on grid relaxation estimates at 65,000 MWD/MTU burnup. The thermal hydraulic test scope included pressure drop (ΔP), life and wear, and flow-induced vibration (FIV) testing. The life and wear test consisted of RCCA drop tests, RCCA stroking tests and the 1000 hour endurance test in an environment representative of in-reactor conditions. The FIV testing served to characterize the flow-induced behavior of the prototype fuel assembly adjacent to a Mark-BW fuel assembly for flow rates representative of reactor startup and normal operation conditions.

3.1.3 Component Testing

In addition to the full-scale prototype testing, various components were also characterized via testing. The spacer grid design was subjected to static buckling and dynamic crush tests. Static compression tests were performed on the hold-down spring and clamp screw. The debris filter bottom nozzle assembly was tested individually for debris filtering efficiency and pressure drop characteristics. The results of all prototype characterization testing have been incorporated into the various analytical models used to support the Mark-BW17 design.

A special case was also analyzed to consider the possible shrinkage of the fuel assembly early in life. This possibility was considered because fuel assemblies fabricated by Framatome with zirconium-niobium guide thimbles similar to Alloy 5 were found [] after two cycles of irradiation at the Ringhals reactor in Sweden. [] Even for a shrinkage ten times that reported for the Framatome assemblies, fuel assembly holddown will be maintained for the North Anna lead test assemblies.

3.2.2 Assembly Compatibility with Control and Insert Components

Evaluations have been performed to address the interfaces between the Mark-BW17 lead test assemblies and the North Anna control and insert components, such as control rods (RCCAs) and discrete burnable absorbers (BPRAs). Many dimensions for the lead test assemblies that are critical to ensuring compatibility with the existing control components, such as the guide thimble pitch, inner diameters and length, the adapter plate elevation, and the top nozzle height, are similar to the corresponding dimensions on the resident Westinghouse fuel. The control and insert component interfaces with the lead test assemblies, including absorber to active fuel overlap as well as both axial and diametral clearances between the guide thimbles and the control and insert rods, have been determined to be satisfactory.

The guide thimble geometry for the Mark-BW17 lead test assemblies is the same as for FCF's standard Mark-BW fuel product. On both fuel designs, the guide thimble dimensions were designed to be similar to the guide thimbles on the Westinghouse 17x17 LOPAR fuel to ensure control rod drop time compatibility. Control rod drop tests were also performed on both the Mark-BW prototype assembly and the Mark-BW17 prototype assembly. The results of these tests show that the control rod drop times for the North Anna lead test assemblies can be expected to be comparable to those for Westinghouse 17x17 LOPAR fuel assemblies at North Anna.

3.2.3 Fuel Assembly Mechanical Compatibility with Resident Fuel

The Mark-BW17 lead test assemblies have envelope dimensions comparable to those of the resident Westinghouse fuel at North Anna. The lead test assemblies will therefore have in-reactor lateral pitch, reactor internal axial clearances, and equipment interfaces similar to those of the resident fuel.

The grid and nozzle interfaces represent the primary locations for mechanical interaction between fuel assemblies. The Mark-BW17 as-built structural grid elevations (Table 3.1) are functionally equivalent to those of the resident fuel assemblies at North Anna. Additionally, worst-case operational grid elevations (i.e., including thermal expansion and irradiation effects) have also been evaluated to ensure that grid elevations match those of the resident fuel assemblies sufficiently to transfer any lateral loads which may occur. It has been confirmed that even for the worst-case comparison of grid elevations, sufficient overlap will remain to permit load transfer.

3.2.4 Fuel Assembly Shipping and Handling Compatibility

Safe transport of the Mark-BW17 lead test assemblies to North Anna is assured by FCF's shipping container design. The container supports for the fuel assemblies are adjustable to accommodate

varying fuel assembly designs. These containers have been used to ship other Westinghouse compatible fuel assemblies (Mark-BW) and are compatible with the Mark-BW17 design.

The interface compatibility of the lead test assemblies with the North Anna handling and storage equipment such as the fuel elevator, upender, and fuel pool racks, is ensured by the mechanical and dimensional similarity of the Mark-BW17 design to Westinghouse (LOPAR, VANTAGE 5H) and other FCF Westinghouse-compatible (Mark-BW) fuel designs. The Mark-BW17 lead test assembly envelope dimensions and structural grid elevations are equivalent to those of resident fuel designs in North Anna (Tables 3.1 and 3.2., providing assurance of the compatibility of the Mark-BW17 assemblies with the North Anna handling equipment. The Mark-BW17 grid design also possesses generous lead-in features to enhance the fuel assembly handling characteristics during core onload and offload.

A specific analysis was conducted by FCF to address the lead test assembly interface with the fuel handling tool. This analysis determined that the Mark-BW17 lead test assembly top nozzle (i.e., the quick disconnect top nozzle design) is fully compatible with the fuel handling tool at the North Anna Power Station.

3.3 Structural Integrity

In order to insure safe and reliable operation of the Mark-BW17 lead test assemblies at North Anna, the structural integrity of the assembly design has been verified for the loading associated with both normal operation and faulted conditions. The evaluations performed to verify the structural integrity of the fuel assembly components under normal operating loads are presented in Section 3.3.1, while Section 3.3.2 addresses control rod drop times for accident evaluations of the Mark-BW17 design. The structural integrity of the fuel assembly under faulted conditions (LOCA and seismic) is covered in Section 3.3.3.

3.3.1 Normal Operation

The FCF structural design requirements for the Mark-BW17 lead test assemblies are derived from past experience with the other Westinghouse-designed plants, as well as experience with other FCF designs, and were verified to conform with North Anna's plant specific design requirements. The evaluations performed to verify the structural integrity of the fuel assembly components are presented in the following sections.

3.3.1.1 Fuel Assembly Holddown Springs

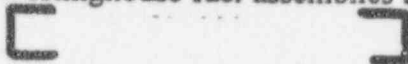
Incorporation of the mid-span mixing grids causes the Mark-BW17 fuel assemblies to have a higher pressure drop than the resident Westinghouse fuel assemblies at North Anna, which do not have intermediate flow mixing grids.  on the Mark-BW17 fuel assembly are designed to:

- accommodate irradiation growth of the fuel assembly,
- accommodate the differential thermal expansion of the fuel assembly and core internals,

- ▶ provide adequate holddown when compared to mechanical design flowrate lift loads, and
- ▶ prevent excessive spring set during pump overspeed conditions.

The springs are designed to provide adequate margin for both the fixed and floating top end grid lead test assembly designs.

The top nozzle and springs are designed to provide positive retention of the holddown springs in the unlikely event of spring failure. The clamp screws, which secure the holddown springs to the top nozzle, are also analyzed to confirm their structural adequacy.

It has been shown that the North Anna lead test assembly top and bottom nozzles will maintain engagement with reactor internals for all Condition I - IV events.

3.3.1.2 Spacer Grids

The design bases for the Zircaloy intermediate spacer grids, Zircaloy mid-span mixing grids and Inconel end grids require that no crushing deformations occur due to normal operation. The Zircaloy intermediate spacer grids and Inconel end grids must also provide adequate support to maintain the fuel rods in a coolable configuration under all conditions. The Zircaloy mid-span mixing grid is designed as a non-contacting grid, but is to provide adequate surface contact to prevent interference between the vanes and the fuel rods.

The mechanical characteristics of the grids are confirmed through a series of tests, including:

- ▶ Dynamic impact tests performed on the spacer grids and mid-span mixing grids to establish allowable impact loads, to characterize the plastic deformation of the grids, and to determine the value of grid deformation at which localized distortion of the guide thimble array would affect insertion of a rod control cluster assembly.
- ▶ Static crush tests of the spacer grids and mid-span mixing grids, to establish allowable grid clamping loads during shipping.
- ▶ Slip load measurements (i.e., the forces required to axially move the Zircaloy spacer grids and Inconel end grids relative to the fuel rods, guide thimbles, and instrument tube), for use as input to analytical models of the fuel assembly.
- ▶ Grid corner hang up tests, conducted on the Zircaloy intermediate spacer grid design to determine the elastic load limit and failure mode of the corner cell (simulating grid hang-up). These tests showed that the failure mode of the corner is through weld fracture, with very little outer strip and corner deformation.
- ▶ Handling tests, conducted using a full scale Mark-BW prototype, to determine the fuel assembly insertion and withdrawal loads. These results remain valid for the North Anna lead test assemblies since the mid-span mixing grids on the Mark-BW17 fuel design have a reduced envelope to resist interface with adjacent assemblies.

3.3.1.3 Top and Bottom Nozzles

Finite element analyses have been performed to ensure the structural adequacy of the Mark-BW17 top and bottom nozzles subjected to conservative shipping and handling (4g), and normal operating loading conditions. The results of the analyses showed that the nozzles meet all design requirements under the specified loads.

3.3.1.4 Guide Thimbles

The guide thimbles were analyzed under normal operating conditions (including mechanical design flowrates, pump overspeed and scram loads) for buckling, primary membrane stress and primary + secondary membrane stress.

Loads were determined using a finite element axial model that is representative of both lead test assembly configurations (fixed and floating top end grids). Both assembly types were analyzed separately for beginning of life conditions due to their differences. At end of life conditions, the floating top end grid is in contact with the quick disconnect sleeves, so the different assembly types are equivalent. Several normal operating conditions were evaluated (including different temperatures and times in life), and effects due to guide thimble mal-distribution and asymmetrical hydraulic lift loads were also accounted for in the analyses.

The allowable buckling loads were based on the maximum compressive yield strength and/or the guide thimble lateral deflection limit. All loading conditions at cold conditions [] and those which included Scram loads are compared to the allowable limits based on the yield strength (because the control components are already fully inserted). For hot conditions [] and those without Scram loads [] which ensures that control rod insertion performance is not affected. Primary and Primary-plus-Secondary membrane stresses are compared to allowable limits based on the ASME code, Section III (Reference 6). The limiting condition was found to be [] Margin to the allowable limits was demonstrated for all expected normal operating conditions.

3.3.1.5 Connections

The ferrule to guide thimble interface is tested to determine the stiffness and strength of the interface. The results of this test, coupled with the results of the guide thimble buckling test, are used to evaluate the floating intermediate and upper end grid restraint system. Sufficient margin exists for the ferrule to grid interface under both operating and handling conditions.

The guide thimble upper and lower connections, such as the quick disconnect sleeve-to-end grid sleeve interface and the bottom end grid sleeve-to-thimble plug crimp, are verified through testing and/or analysis. Process qualifications are also performed for the weld, swage, and crimp-type connections to ensure repeatability.

3.3.2 Control Rod Drop Times

The design bases for the fuel assembly states that the fuel assembly shall not experience any permanent deformation during either a Condition I or II event that would cause the control component drop time to increase beyond the allowable limits. The maximum allowable control rod drop time specified in the North Anna Technical Specifications (References 7 and 8) is 2.7 seconds, measured from the start of control rod spider movement until the control rod enters the dashpot region of the guide thimbles.

Excure testing has been conducted by FCF on the Mark-BW and Mark-BW17 prototype assemblies at temperatures and flow rates that are representative of operating conditions. The maximum measured control rod drop times in these tests were [] respectively. Incore drop tests at units using the Mark-BW fuel design have typically resulted in drop times that were about [] higher, with no apparent dependence on assembly burnup.

An evaluation based on the resident North Anna control rod assemblies has determined that there would be no restriction of rod insertion into the lead test assemblies under normal operating conditions. Comparison of the guide thimble diameters for the resident Westinghouse fuel to those of the FCF Mark-BW17 lead test assemblies (refer to Table 3.2) shows that the guide thimble diameter for the resident NAIF fuel design (with either Zircaloy-4 and ZIRLO guide thimbles) is smaller than on the FCF lead test assemblies, which are directly comparable to the Westinghouse LOPAR fuel design. Thus, drop times for the FCF lead test assemblies are expected to be faster than those for the most recent reload fuel at North Anna, and comparable to the North Anna drop times in the older LOPAR fuel assemblies.

3.3.3 Seismic and LOCA Evaluation

The criteria for the fuel assembly seismic and LOCA analyses are consistent with the acceptance criteria of the Standard Review Plan (NUREG-0800), Section 4.2. (Reference 9). Specifically:

- a. The fuel assembly is designed to ensure safe operation following an Operational Basis Earthquake (OBE). For the Safe Shutdown Earthquake (SSE), the calculated spacer grid impact loads are within the elastic load limit. Because the magnitude of the OBE is usually about half the magnitude of the SSE, these results also satisfy the OBE requirements, that the assembly or component not exceed its yield limit. Hence a separate OBE analysis was not required for the North Anna lead test assemblies.
- b. The fuel assembly is designed to allow control rod insertion and to maintain a coolable geometry during a Safe Shutdown Earthquake. A separate Safe Shutdown Earthquake analysis was done to ensure that the fuel assembly does not sustain permanent damage that will impede control rod insertion and core coolability. For the North Anna lead test assemblies, there is no permanent deformation. Therefore the requirements of control rod insertion and coolable geometry are met.

- c. The fuel assembly is designed to allow for the safe shutdown of the reactor system following a Loss of Coolant Accident (LOCA) or combined LOCA/SSE by maintaining the overall structural integrity and a coolable geometry. This criterion places limits on the permanent deformations to which spacer grids may be subjected. For the North Anna lead test assembly LOCA cases and the combined LOCA/SSE cases, the calculated spacer grid loads are less than the elastic load limit value. Therefore, the grids sustain no permanent deformations and no further calculation was required to ensure that the coolable geometry requirements were met.

3.3.3.1 Mixed Core Horizontal Seismic and LOCA Loads

A bounding analysis for a mixed core of the resident Westinghouse fuel and the FCF Mark-BW17 lead test assemblies (LTAs) was performed for the combined seismic and Loss of Coolant Accident (LOCA) events. Core coolable geometry will be maintained for all the faulted loads. Interactive spacer grid impact loads were assessed to show the compliance with the core coolable geometry requirement. - ..

The static (lateral stiffness) and dynamic (natural frequency and damping) characteristics of the Mark-BW17 lead test assemblies and production VANTAGE-5H fuel assemblies were determined analytically and experimentally. These characteristics were found to be compatible due to similarities in assembly geometry and construction.

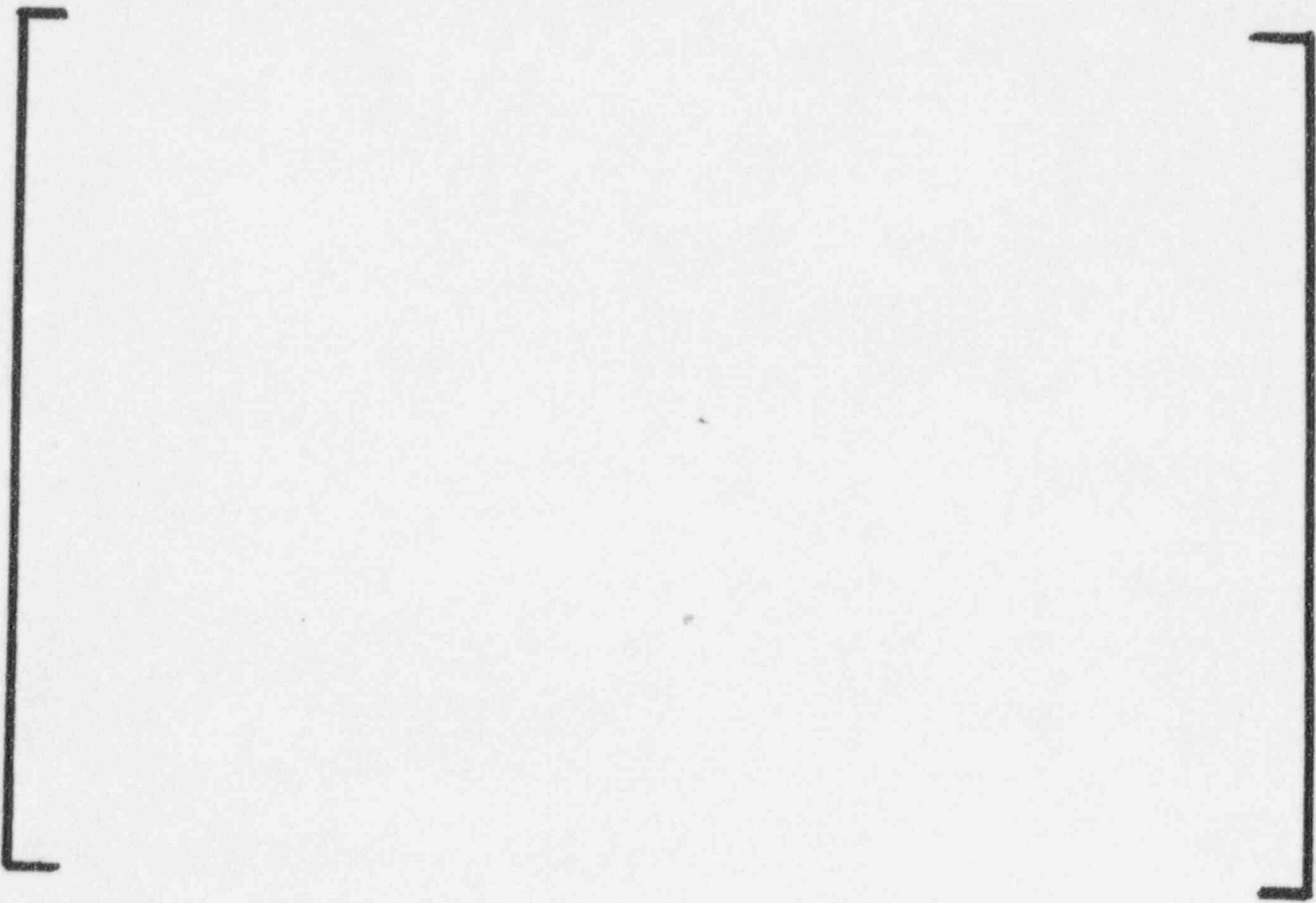

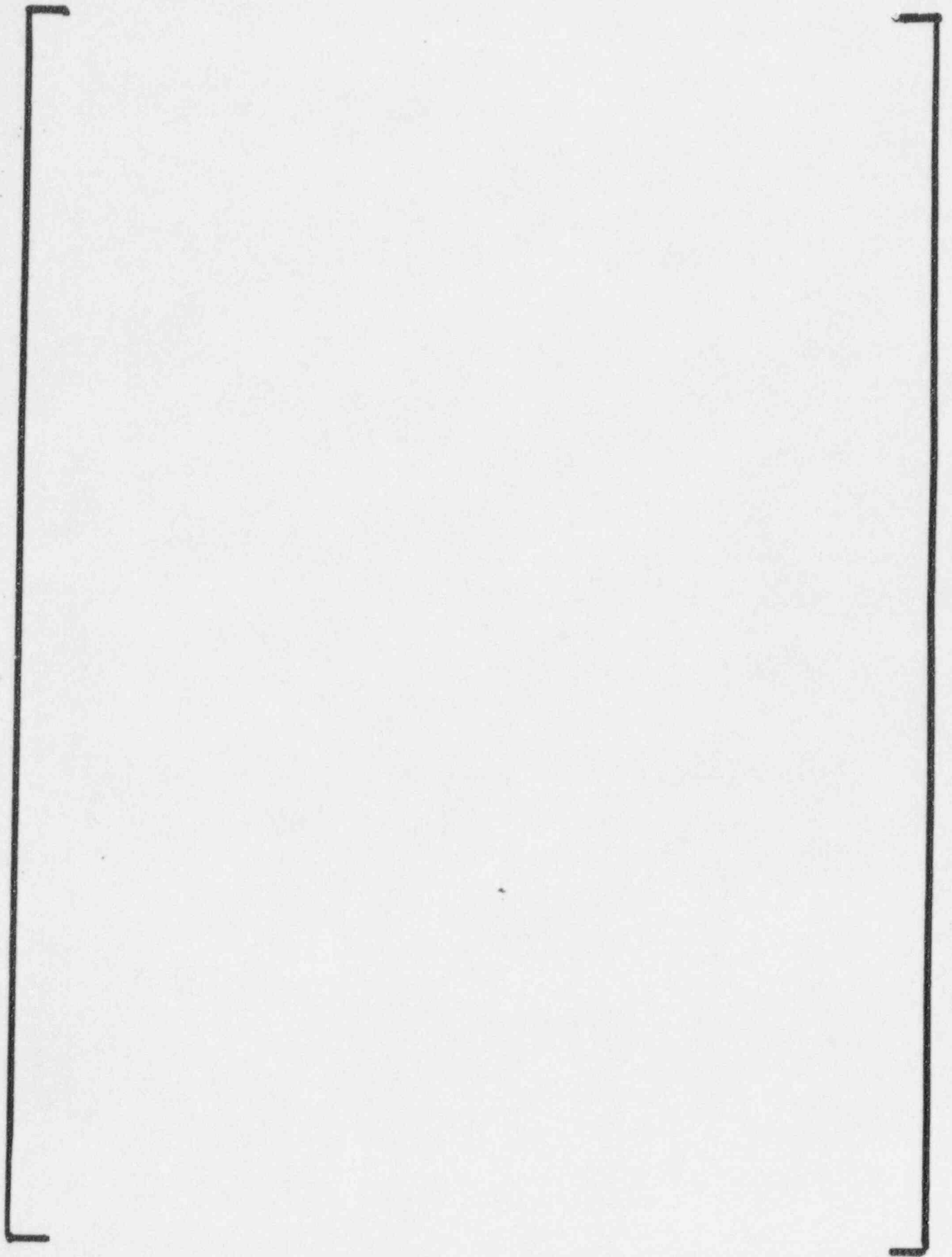

3.3.3.2 Vertical LOCA Analysis

One design difference between the Westinghouse and the FCF fuel assembly designs is in the method of restraining the spacer grids, as described in Section 1.3. Although the overall assembly vertical stiffness and the strength of the two designs should be the same, to confirm that the FCF guide thimbles will allow control rod insertion during a LOCA a separate vertical LOCA analysis was performed to confirm the structural integrity of the FCF guide thimbles. Only the LOCA cases were evaluated in the vertical direction as the upper and lower core plates move in phase for the seismic case and cause no fuel assembly loading.

3.4 Fuel Rod Design

A series of analyses was performed for the lead test assembly fuel rod design to confirm that the fuel rods with the advanced zirconium-alloy claddings will exhibit satisfactory in-reactor mechanical performance. These analyses included: cladding stress and strain, cladding fatigue, creep collapse, fuel rod growth, corrosion, shipping and handling loads, and fretting wear. An evaluation of the end of life fuel rod internal pressure was also performed. The analyses in these areas, summarized below, demonstrate that the lead test assembly fuel rods will perform satisfactorily to burnups exceeding Virginia Electric and Power Company's NRC-imposed lead rod burnup limit of 60 GWD/MTU.

3.4.1 Fuel Rod Cladding Stress

The operation-induced stresses in the fuel rod cladding were evaluated using conservative values for physical parameters such as cladding thickness, oxide layer buildup, external pressure, internal fuel rod pressure, differential temperature, and unirradiated cladding yield strength. The ASME pressure vessel stress intensity limits (Reference 6) are used as guidelines for this evaluation.

The clad stresses for the Alloy 4 and Alloy 5 clad fuel rods in the North Anna lead test assemblies were evaluated in the same manner as the fuel rods in the previous demonstration programs. This involves dividing the stresses into compressive and tensile stresses according to criteria given in Reference 11. The stress level intensities were calculated in accordance with the ASME code, and include both normal and shear stress effects. The stress intensities were then compared to the ASME criteria, as follows:

- I. Primary general membrane stress intensities (P_m) must not exceed S_m .

- II. Local primary membrane stress intensities (P_1) must not exceed $1.5 \cdot S_m$. These include the contact stresses from spacer grid-fuel rod contact. The total of the local primary membrane and bending stress intensities ($P_1 + P_b$) must not exceed $1.5 \cdot S_m$.
- III. The sum of the local primary membrane, bending, and secondary stress intensities ($P_1 + P_b + Q$) must not exceed $3.0 \cdot S_m$.

For the beginning of life tensile stresses, S_m is defined as 2/3 of the minimum unirradiated yield strength of the cladding, consistent with the ASME code. The worst case tensile stress condition occurs late in the life of the fuel rod, and is enveloped by the stress calculations for the hardened cladding. For the compressive stresses, S_m is set equal to the minimum unirradiated hoop yield strength of the cladding at operating temperature, consistent with Reference 11.

It was determined that the calculated stresses for the fuel rods in the North Anna lead test assemblies will be within the prescribed limits.

3.4.2 Fuel Rod Cladding Strain

The fuel rod was analyzed to determine the maximum transient the fuel rod could experience before the transient strain limit of 1% is exceeded. The transient strain limit evaluation uses cladding circumferential changes before and after a linear heat rate transient to determine the strain. This analysis is performed using the TACO3 fuel rod thermal analysis code (Reference 12). Both the Alloy 4 and Alloy 5 materials have a relatively high creep strength compared to Zircaloy-4, and the creep rates of both materials are less than [] of Zircaloy-4. It was determined that the calculated linear heat rates which would result in 1% cladding strain for rods with Alloy 4 and Alloy 5 cladding are much greater than the maximum transient the North Anna lead test assembly fuel rods are expected to experience.

3.4.3 Fuel Rod Fatigue Usage

The total fatigue usage factor for the North Anna Alloy 4 and Alloy 5 fuel rods was analyzed using the ASME pressure vessel code as a guideline. Testing conducted by Framatome Fuel Division in France has shown the recrystallized claddings to have fatigue endurance performance similar to Zircaloy-4, []
The Alloy 4 and Alloy 5 data are well enveloped by the standard Langer-O'Donnell design fatigue curve for irradiated Zircaloy. All possible Condition I and Condition II events that would be experienced by the lead test assembly fuel rods over a (conservative) lifetime of 8 years were assumed, along with one Condition III event. Conservative inputs were also assumed for cladding thickness, oxide layer buildup, external pressure, internal fuel rod pressure and differential pressure across the cladding. This analysis for the North Anna lead test assembly fuel rod resulted in a fatigue usage factor of [] which is well below the maximum allowable fatigue usage factor of 0.9.

3.4.4 Fuel Rod Cladding Creep Collapse

The fuel rod creep collapse analysis is performed in accordance with the NRC-approved

methodology described in Reference 13. Fuel rod failure due to collapse is predicted to occur when either:

1. the rate of creep ovalization exceeds 0.1 mil/hr, or
2. the maximum fiber stress exceeds the unirradiated yield strength of the cladding.

The creep rate of Alloy 4 and Alloy 5 is approximately [] that of Zircaloy-4. Therefore an appropriate multiplier was used on the creep model in this analysis to represent the behavior of the Alloy 4 and Alloy 5 materials. It was determined that North Anna lead test assembly fuel rod creep collapse lifetime is greater than the expected in-core life of the fuel.

3.4.5 Fuel Rod Cladding Corrosion

One of the major purposes for development of the advanced zirconium based alloys was to obtain a reduction in the amount of cladding corrosion relative to Zircaloy-4. Both Alloy 4 and Alloy 5 exhibit a strong resistance to corrosion, with irradiation experience to date showing the corrosion of these materials to be less than [] the corrosion of low-tin Zircaloy-4 claddings. An evaluation based on the current FCF database for Alloy 4 and Alloy 5 predicted an upper limit on cladding oxidation of [] which is less than [] of the limit.

The hydrogen pick-up rates of the Alloy 4 and Alloy 5 cladding materials have been found to be approximately [] respectively. For the predicted corrosion level, the upper limit for hydrogen content of the advanced claddings at the end of the lead test assembly operating lifetime will be approximately [] of the FCF upper limit for hydrogen pick-up.

This level of oxidation and associated hydriding will not adversely affect the structural integrity of the North Anna lead test assembly fuel rod during its design lifetime.

3.4.6 Fuel Rod Shipping and Handling Loads

The fuel rods in the North Anna lead test assemblies are designed to withstand a 4g load during shipment and handling of the fuel assembly without the formation of gaps between pellets in the fuel stack. This design condition is achieved by using a stainless steel spring in the upper plenum of the fuel rod. The dimensions of this spring have been specified to ensure that the spring will maintain a 4g pre-load on the fuel stack, prohibiting the formation of gaps within the fuel stack.

3.4.7 Fuel Rod Fretting Wear

A life and wear test has been conducted at maximum reactor flow conditions for 1000 hours to evaluate the fretting characteristics of the fuel rods and spacer grids. The preliminary results of this test showed no indication of fretting wear of the fuel rods.

Extensive operational experience with the Mark-BW design, using grid designs and fuel rod dimensions comparable to those of the North Anna lead test assemblies, has shown only one fuel rod fretting failure. This failure occurred in a corner grid cell of the lower end grid, and was determined

to be caused by either manufacturing or operational damage to the cell. To improve the fretting performance of the grid, a design change was subsequently implemented to increase the force exerted on the fuel rod by the corner cell spring stop.

The modification to the mixing vane pattern on the Mark-BW17 vaned grids, described in Section 1.3.1, is very small and will not affect the flow induced vibration performance of the fuel assembly relative to that previously seen with the Mark-BW design. Flow induced vibration testing has also been performed with prototype assemblies to demonstrate that fuel rod fretting wear will not occur in Mark-BW17 assemblies incorporating mid-span mixing grids.

Based on previous operating experience and on both life and wear and flow induced vibration testing, no fuel rod wear due to fretting is expected in the North Anna lead test assemblies.

3.4.8 Fuel Rod Growth

The axial gap between the fuel rods and the lead test assembly top nozzle was analyzed to verify that sufficient margin exists to accommodate fuel rod growth for the operating life of the fuel assemblies. To calculate the closure of this gap, the upper tolerance growth of Alloy 4 and Alloy 5 is used with a conservative assumption of zero fuel assembly growth. Contact between the Alloy 4 and Alloy 5 fuel rods and the fuel assembly top nozzle will not occur during the design life of the lead test assemblies.



3.4.9 Fuel Rod Internal Pressure

Fuel rod thermal performance analyses, including evaluation of the end of life rod internal pressure, were performed with the NRC-approved TACO3 fuel rod thermal performance code (Reference 12). The TACO3 code and internal gas pressure methodology have been extended to address operation with internal pressure greater than reactor coolant system pressure in the NRC-approved topical report BAW-10183P-A (Reference 14).

Maximum fuel rod internal pressure was determined using a pin power history and axial flux shapes provided by the Virginia Electric and Power Company. The power history and axial flux shapes (both steady state and transient shapes) were generated in a manner consistent with FCF's NRC-approved methodologies, using Virginia Electric and Power Company's standard design codes. The enveloping power history used represents the peak fuel rod in core over the burnup history, and is a composite from four previous North Anna fuel cycle designs. This power history bounds the planned irradiation of the Mark-BW17 lead test assemblies at North Anna. It was determined that

the end of life fuel rod internal pressure will remain below the FCF criterion for operation above system pressure defined in Reference 14.

Prior to each operating cycle, the cycle specific pin power histories for the lead test assemblies will be compared to the power history envelope assumed for this analysis. Should the cycle specific peak pin power for the lead test assemblies violate the envelope, then either the power history envelope can be adjusted locally and an analysis performed to demonstrate that the pin pressure remains below an acceptable level.

4. Thermal Hydraulic Design

Analyses of the thermal and hydraulic compatibility of the four FCF lead test assemblies with the resident Westinghouse fuel at North Anna were performed by FCF using NRC-approved models and methods. These analyses addressed areas such as unrecoverable core pressure drop, hydraulic lift forces, inter-bundle crossflow, and DNB performance.

4.1 Design Comparison

The components of the Mark-BW17 lead test assemblies and resident Westinghouse fuel assemblies are hydraulically similar with the exception of a slightly smaller thimble tube diameter for the recent Westinghouse fuel designs and higher grid pressure drop for the Mark-BW17 design. The Mark-BW17 lead test assemblies for North Anna also incorporate three additional mid-span mixing grids between the top four standard Zircaloy mixing vane grids for enhanced thermal margin. A similar component is not currently utilized on the resident fuel.

4.2 Calculational Methods

The calculational methods currently used on the Mark-BW product for use in Westinghouse reactors are applicable to the evaluation of a core containing both Mark-BW lead test assemblies and the Westinghouse fuel products. The thermal and hydraulic (pressure drop, lift force, crossflow, and DNB) analysis of the FCF lead test assemblies was performed by FCF using the LYNXT code (Reference 15). LYNXT is a single-pass code which employs crossflow methodologies to evaluate subchannel thermal-hydraulic conditions for both steady-state and transient analyses. Two LYNXT models of the North Anna core were used for the evaluations. An eighth core 26-channel bundle-by-bundle model was used for the hydraulic analyses and a 12-channel model was used for the DNB analyses.

The DNB analysis of the Mark-BW17 lead test assemblies was performed using FCF's Statistical Core Design (SCD) methodology. The NRC has approved the SCD methodology for both B&W- and Westinghouse-designed reactors in Topical Reports BAW-10187P-A and BAW-10170P-A (References 16 and 17), respectively. DNB analyses to support use of the Mark-BW17 lead test assemblies at North Anna were performed using two NRC-approved critical heat flux (CHF) correlations: the BWCMV-A CHF correlation (Reference 18), and the BWU-Z CHF correlation (Reference 19). The Mark-BW17 fuel assemblies show improved DNB performance relative to the

resident Westinghouse fuel, in part due to the Mark-BW17 mixing vane design, but also from the addition of three mid-span mixing grids, as described in Section 1.4. The enhanced DNB performance obtained from the use of the mid-span mixing grids was evaluated by means of a spacer grid spacing factor incorporated into the BWCMV-A CHF correlation. (Z correlation.)

4.3 Hydraulic Compatibility

The pressure drop of the Mark-BW17 lead test assemblies is higher than that for North Anna's resident Westinghouse fuel assemblies, primarily due to the presence of the MSMGs on the Mark-BW17 design.

The net effect is a flow diversion from the Mark-BW17 lead test assemblies to the surrounding Westinghouse fuel assemblies.

4.3.1 Grid Pressure Drop

The grid pressure drops for the Mark-BW17 lead test assembly were measured in Framatome's HERMES P loop in Cadarache, France. The HERMES P loop operates at PWR primary coolant conditions (600°F, 2250 psia). Component form loss coefficients for analyses were determined from this pressure drop data.

Core pressure drop data for the resident Westinghouse fuel assemblies were obtained from Westinghouse and used to analytically determine the grid form loss coefficients.

4.3.2 Core Pressure Drop

The core pressure drop across the fuel assemblies consists of contraction and expansion, friction, elevation, and crossflow losses. The core pressure drop was determined for a full core of Mark-BW17 fuel and a full core of current North Anna Improved Fuel assemblies.

The following results were obtained for 100% core power at a core flowrate of 330,000 gpm:

Mark-BW17 Core
Westinghouse Core

[]

These results demonstrate that the predicted pressure drop for a full core of Mark-BW17 fuel assemblies is within 6% of the resident fuel, which is considered negligible. The core pressure drop of the mixed-core is bracketed by the pressure drop values for full cores of each design.

4.3.3 Lift

The fuel assembly hydraulic lift force for the Mark-BW17 lead test assemblies was determined for the limiting core configuration, which - because of their higher pressure drop - is a homogeneous

core of Mark-BW17 fuel assemblies. Hydraulic lift forces were determined for the Mark-BW17 design at both isothermal and 'at power' conditions. Analyses were performed for core flowrate at both the Mechanical Design and the Pump Overspeed ('at power' only) conditions. The results of these analyses were used in the evaluation of fuel assembly holddown springs in Section 3.3.1.1.

The effect of the Mark-BW17 lead test assemblies on lift of the resident fuel was assessed with a mixed core analysis. The total predicted lift forces were compared for the North Anna core with and without the FCF Mark-BW17 assemblies. The results of the mixed core analysis indicated that the lift performance of the resident fuel was insignificantly affected by the presence of the lead test assemblies.

4.3.4 Crossflow Velocity

Span average crossflow velocities are used to consider the integrated effects over the total span. A [] span average value is a conservative criterion that has been used historically on a variety of designs to preclude unacceptable flow induced vibration of the fuel rods. Mixed core analyses assuming a single Mark-BW17 fuel assembly in a core of Westinghouse fuel assemblies demonstrate span average crossflows are less than the [] (span average) criterion.

4.3.5 Component Bypass Flow

Component bypass flow through the Mark-BW17 lead test assembly guide thimbles was conservatively evaluated assuming a full core of Mark-BW17 fuel assemblies at conditions representative of North Anna. The effect on the overall core bypass was determined to be negligible.

4.4 DNB Performance Evaluation

To demonstrate that the DNB performance of the Mark-BW17 lead test assemblies is non-limiting, calculations were performed by the Virginia Electric and Power Company for the resident Westinghouse fuel and by FCF for the mixed core configuration using the applicable statistical DNBR methodologies and CHF correlations. The DNBR results were compared to the fuel specific thermal design limits. These calculations, described below, demonstrate that the lead test assemblies have more margin to their applicable DNB limit than the resident Westinghouse fuel has to its limit. Cycle specific and UFSAR non-LOCA analyses with DNB acceptance criteria which assume a full core of Westinghouse fuel will therefore be conservative for North Anna cores containing the lead test assemblies.

4.4.1 Statistical Core Design (SCD)

The FCF Statistical Core Design (SCD) uses a statistical combination of uncertainties technique. In the SCD method, input uncertainties are analyzed using statistical methods and an overall DNBR uncertainty is determined. This overall uncertainty is then used to establish a design limit DNBR known as the Statistical Design Limit (SDL). For added flexibility, margin is added to the SDL. This added margin defines an analysis limit termed the Thermal Design Limit (TDL). Once the TDL has been established, the calculated DNBR at a specific core state is compared to the SDL to

determine if the DNB protection criterion is met.

For the planned insertion of the Mark-BW17 lead test assemblies into North Anna, the plant specific variables listed in Table 4.1 were used to determine Statistical Design Limits for the BWCMV-A and BWU-Z CHF correlations. The ranges and uncertainties of these variables are consistent with those used for the implementation of the Virginia Electric and Power Company Statistical DNBR Evaluation Methodology (Reference 20) for North Anna (Reference 21). The resulting SDL values are [] for BWCMV-A correlation, and [] for the BWU-Z correlation.

4.4.2 Retained DNB Margin

For application of the SCD method to North Anna cores with the Mark-BW17 lead test assemblies, the retained margin added to the SDL is [] and is defined by the following formula:

$$\text{Retained thermal margin (\%)} = \frac{\text{TDL} - \text{SDL}}{\text{TDL}} \times 100$$

This results in a Thermal Design Limit of 1.58 for the BWCMV-A CHF correlation, and 1.49 for the BWU-Z correlation.

4.4.3 DNB Analysis and Results

Statepoints were developed by Virginia Electric and Power Company to represent points on the safety limit line, limiting axial flux shapes, highly peaked radial power distributions, and low flow conditions for the resident Westinghouse fuel at its thermal design limit of 1.46 (Reference 21).

For the FCF DNB analyses, the North Anna core was modelled with the LYNXT code using the 12 channel model. The core configuration consisted of a single Mark-BW17 fuel assembly in a core with the remaining assemblies being modeled as Westinghouse fuel. This configuration is limiting because of the higher pressure drop of the Mark-BW17 fuel assembly relative to the current North Anna fuel design, which results in flow being diverted from the lead test assemblies to the resident fuel. The predicted MDNBRs for the LTAs were obtained at the statepoints provided by Virginia Electric and Power Company using the BWCMV-A and BWU-Z correlations, and were determined to be greater than the applicable TDLs.

4.5 Rod Bow

The rod bow behavior in the Mark-BW17 lead test assemblies should be comparable to or less than that of Mark-BW fuel. Because essentially the same grid designs and fuel rod dimensions are used in both fuel assembly designs, similar grid forces are exerted on the fuel rods. Each design is self-consistent in the use of materials for fuel rods and guide thimbles, with the Mark-BW fuel using Zircaloy-4 cladding and guide thimbles, and the Mark-BW17 lead test assemblies using Alloy-4 and Alloy-5 (or all Alloy-5) cladding in skeletons with Alloy-5 guide thimbles. The low growth characteristics of the Alloy 4 and Alloy 5 advanced materials, which have been demonstrated

through irradiation experience, are expected to contribute to reductions in fuel rod and fuel assembly bow. The Mark-BW17 fuel design can therefore be reasonably expected to exhibit rod bow behavior no worse than that previously seen for the Zircaloy-4 clad fuel rods in Mark-BW fuel assemblies. The same approach to incorporating the effect of fuel rod bow on DNBR that is used for Mark-BW fuel assemblies is therefore also applicable to the lead test assemblies.

The phenomenon of fuel rod bowing is accounted for in DNBR safety analysis by assessing a [] DNBR penalty for burnups less than [] No DNBR penalty is assessed for burnups greater than 24 GWD/MTU since design peaking factors cannot be reached (References 22 and 23). The [] penalty is accounted for by a [] allowance that is incorporated into the bundle spacing parameter (shown in Table 4.1), which is combined statistically with other uncertainties to establish the statistical design limit (SDL) DNBR.

4.6 Fuel Temperatures

The fuel temperatures were evaluated for the lead test assemblies using FCF's TACO3 fuel rod thermal performance code (Reference 12). The peak local power at which fuel melt is predicted to begin was calculated as a function of burnup. The results of these calculations show that, over the planned operating life of the lead test assemblies, the minimum linear heat generation rate at which fuel melting will occur exceeds the minimum linear heat generation rate used by Virginia Electric and Power Company in the reload safety analysis calculations for North Anna to ensure that fuel melt does not occur in the resident Westinghouse fuel. Therefore, Virginia Electric and Power Company's standard reload design process criterion can be conservatively applied to cycle specific designs for North Anna cores incorporating the lead test assemblies to ensure that fuel melt does not occur in either the FCF or the resident Westinghouse fuel assemblies.

4.7 Impact on Reload Evaluation Methodology

The analyses performed by FCF have demonstrated that use of the four lead test assemblies in a core of Westinghouse fuel will have a negligible impact on the core pressure drop, hydraulic lift forces on the resident fuel, span average crossflow, and overall core bypass flow. The DNB performance of the lead test assemblies is bounded by the DNB performance of the resident Westinghouse fuel. Therefore, cycle specific thermal hydraulic evaluations for North Anna cores containing the four lead test assemblies can conservatively be modeled as a homogeneous core of Westinghouse fuel assemblies. There is no impact on the models or methods normally used by Virginia Electric and Power Company to perform thermal hydraulic analyses of the core, and no transition core penalties must be applied.

5. Neutronic Performance

The physical differences between the Mark-BW17 lead test assemblies and the resident Westinghouse fuel are small. Cycle specific neutronic calculations will account for the effects of the composition of the Alloy 4 and Alloy 5 fuel rod cladding materials and the use of Alloy 5 for the guide thimbles and instrument tube. The presence of the Zircaloy-4 mid-span mixing grids and the impact of the higher nominal fuel density will also be incorporated into the analyses. As a result of

the general physical similarity to the resident Westinghouse fuel designs, the Mark-BW17 LTAs have essentially the same neutronic behavior as the resident fuel assemblies.

On an equal enrichment basis, the Mark-BW17 lead test assemblies initially exhibit reactivity similar to the resident Westinghouse fuel. Due to the higher uranium loading (primarily the result of a higher nominal fuel density), the rate of depletion of reactivity is slightly smaller for the lead test assemblies than for the majority of the fuel in the North Anna core. This difference will be explicitly modeled in the cycle specific neutronic calculations and will not have any adverse impact on the operation of the plant.

To ensure that meaningful data are obtained on the performance of the lead test assembly new design features and advanced materials, these assemblies will be placed in high power locations, particularly in the first two operating cycles, and are expected to achieve assembly average burnups over 50,000 MWD/MTU in three operating cycles. Although the fuel will experience moderately severe duty typical of normal reload fuel, to ensure that the existing safety analyses based on the resident Westinghouse fuel remain applicable, the core locations will be selected so that the FCF assemblies are not placed in the highest fuel rod power density locations in the core. The lead test assemblies will not be limiting with respect to any safety analysis limit, meaning that F_Q and $F_{\Delta H}$ margins will be preserved for the lead test assemblies and they will not set any safety or operating limits. In addition, the lead test assemblies will not have the highest cycle-averaged assembly average power for any given cycle.

The North Anna core reactivity coefficients and nuclear performance for cores containing the FCF lead test assemblies will not be noticeably different from recent reload cores consisting of all Westinghouse fuel. Cores containing fuel with a variety of Westinghouse design features (e.g., different cladding materials; Inconel, Zircaloy-4 and/or ZIRLO mixing vane grids; minor changes to fuel loading due to pellet dish and chamfer dimension changes as well as normal manufacturing variations in pellet density; small changes to grid and stack axial elevations; and fuel assemblies with and without protective grids) have shown acceptable power peaking and reactivity behavior. Past changes made to the neutronic model inputs to incorporate these material and design changes to the Westinghouse fuel products, as well as other more (neutronically) significant product changes such as burnable poison design changes, use of vibration suppression inserts, and use of flux suppression inserts at Surry Unit 1, have been incorporated with fully acceptable predicted-to-measured power distribution and reactivity parameter agreement. Changes to the neutronic model inputs necessary to model the physical differences between the lead test assemblies and the resident Westinghouse fuel assemblies are similar to those used for previous Westinghouse fuel product changes, and are of a smaller magnitude than was necessary for many of the Westinghouse fuel product changes. Therefore it is concluded that the Nuclear Design Reliability Factors specified in Reference 24 remain applicable for use with the lead test assemblies. It is also concluded that the methods and models used to verify local rod powers for Relaxed Power Distribution Control analyses (Reference 25) remain valid for use with the lead test assemblies. Use of the Mark-BW17 lead test assemblies in conjunction with the Westinghouse fuel in the North Anna cores will not adversely affect plant operation or neutronic parameters.

The use of the lead test assemblies will also have no significant impact on spent fuel pool

calculations. Margin in existing North Anna spent fuel pool analyses will more than account for the additional amount of uranium present in the FCF lead test assemblies. Therefore the North Anna spent fuel pool analyses will remain bounding for the lead test assemblies.

6. Non-LOCA Safety Evaluations

The performance of the Mark-BW17 lead test assemblies under postulated non-LOCA accident conditions was evaluated by the Virginia Electric and Power Company. The intent of the evaluation was to assess the applicability of the existing non-LOCA safety analyses, which assume a full core of North Anna Improved Fuel (NAIF) assemblies, to cores containing the FCF lead test assemblies.

6.1 Assembly Design Comparison

In this evaluation, the design features used as key parameters in accident analyses were compared between the Mark-BW17 and North Anna Improved Fuel (NAIF) designs. The features reviewed included dimensional data for the fuel pellets, fuel rod, and fuel assembly features. In addition, material properties for the Alloy 4 and Alloy 5 were compared with the Zircaloy-4 and ZIRLO materials used in the Westinghouse fuel rods. The majority of design features are identical or comparable between the Mark-BW17 and NAIF designs. Only a limited number of characteristics that are relevant for NSSS accident analysis exhibit any difference from the existing NAIF design. The following Mark-BW17 features are different in the manner indicated relative to the NAIF design:

1. Increased fuel assembly pressure drop
2. Reduced fuel average temperature
3. Presence of Mid-Span Mixing Grids (MSMGs)
4. Increased guide thimble tube inner and outer diameter
5. Reduced cladding alpha-beta phase shift temperature

6.2 Events with DNB Acceptance Criterion

These differences for the FCF Mark-BW17 fuel assembly design were evaluated for potential impact upon the existing analysis of record for non-LOCA events. For this purpose, the events have been divided into two categories: (1) events with a DNB acceptance criterion, and (2) events with all other acceptance criteria. The DNB performance of the Mark-BW17 fuel assemblies for operation in the North Anna cores is documented in Section 4.4. These DNB analyses have accounted for the effects of the Mark-BW17 pressure drop, presence of MSMGs and guide thimble tube dimensions (Items 1, 3 and 4 above). These features affect key parameter inputs for core and bypass flowrates which are relevant only for DNB analyses. The analysis results demonstrate that the DNB margin for the FCF Mark-BW17 fuel assemblies is greater than that of NAIF, with respect to their applicable DNB correlations and limits, for bounding mixed core configurations. The assessment demonstrates that DNB analyses performed for full cores of NAIF provide bounding results for application to the Mark-BW17 design. These analyses thus verify that existing non-LOCA event analyses for North Anna with a DNB acceptance criterion are conservative licensing analyses for the Mark-BW17 lead test assemblies. This DNB-related assessment applies to the following NSSS events, which have

a DNB acceptance criterion:

- Uncontrolled RCCA Bank Withdrawal from a Subcritical Condition
- Uncontrolled RCCA Bank Withdrawal at Power
- Rod Cluster Control Assembly Misalignment
- Uncontrolled Boron Dilution
- Startup of an Inactive Reactor Coolant Loop
- Spurious Operation of the Safety Injection System at Power
- Loss of External Electrical Load
- Excessive Heat Removal Due to Feedwater System Malfunctions
- Excessive Load Increase Incident
- Accidental Depressurization of the Reactor Coolant System
- Accidental Depressurization of the Main Steam System
- Main Steamline Rupture
- Complete Loss of Reactor Coolant Flow
- Single Reactor Coolant Pump Locked Rotor
- Single RCCA Withdrawal at Full Power

In addition to physical features, a separate assessment of the features that govern neutronic behavior as modeled in Virginia Electric and Power Company's core reload methodology concluded that there are no differences between the Mark-BW17 and NAIF designs which either invalidate an existing key physics parameter limit value or require the introduction of a new parameter for accident analysis. A more detailed description concerning the assessment of neutronic similarity between the Mark-BW17 and NAIF fuel assemblies was presented in Section 5 of this Safety Significance evaluation.

6.3 Events with Non-DNB Acceptance Criteria

The fuel design feature differences noted above also have the potential to affect results of the non-LOCA events which do not have a DNB acceptance criterion. These events are listed below.

- Loss of Normal Feedwater
- Loss of Offsite Power to the Station Auxiliaries
- Spurious Operation of the Safety Injection System at Power
- Steam Generator Tube Rupture
- Single Reactor Coolant Pump Locked Rotor
- Fuel Handling Accident (Inside and Outside Containment)
- Major Rupture of a Main Feedwater Line
- Rupture of a Control Rod Drive Mechanism Housing (Rod Ejection)

Virginia Electric and Power Company conducted a review to determine the impact on the non-DNB NSSS accident analyses. It was concluded that the only key parameters affected are those used as inputs for the two events that involve a detailed cladding temperature calculation: the Locked Rotor and Rod Ejection events.

The reduced fuel average temperature of the Mark-BW17 design relative to the NAIF fuel is a benefit for cladding temperature analyses, and requires no further evaluation. The difference in the phase shift temperature of the Mark-BW17 advanced alloy claddings impacts the cladding heat capacity at temperatures within the alpha-beta phase shift region. This behavior has previously been evaluated for the use of Westinghouse's ZIRLO alloy, which exhibits similar characteristics.

FCF has determined that the thermal properties of Zircaloy-4 and Alloy 4 are the same, and that the use of Zircaloy-4 properties is acceptable for modeling Alloy 4 in analyses. The Alloy 5 and Zircaloy-4 properties are also comparable, with the exception of the difference in the alpha-beta phase change temperature. Alloy 5 and Zircaloy-4 have essentially identical heat capacities up to approximately [] when the Alloy 5 material undergoes an alpha-beta phase change. The Alloy 5 specific heat then decreases to the value applicable to the beta phase. Zircaloy-4 exhibits similar behavior, but the onset of the phase change occurs at a higher temperature (approximately 1500°F), and the peak specific heat value reached during the transition is higher than for Alloy 5. Both Alloy 5 and Zircaloy-4 become pure beta at approximately 1800°F. Since the total energy required to alter the crystalline structure of the two alloys is essentially the same and the Alloy 5 phase shift begins at a lower temperature, Alloy 5 has a broader functional relationship between the heat capacity and temperature than does Zircaloy-4. These differences in heat capacity between Alloy 5 and Zircaloy-4 can have a small effect on calculated cladding temperatures for transients with limiting temperatures in the phase transition zone []

A review of the North Anna non-LOCA licensing basis analysis results indicated that only the cladding temperature calculations for the Locked Rotor and Rod Ejection events exceed [] For each of these events, the peak cladding temperature rapidly passes through the alpha-beta transition zone, reaching values well into the beta phase. For such transients, there is a negligible effect on the calculated cladding temperature. It is therefore concluded that the existing analyses which are based on the thermal characteristics of Zircaloy-4 are acceptable for evaluation of both Alloy 4 and Alloy 5.

For the Locked Rotor and Rod Ejection events, transient behavior is also dependent upon detailed fuel assembly design features such as pellet and cladding geometry. Virginia Electric and Power Company performs analyses of cladding temperature behavior for these events using the RETRAN Hot Spot Model (Reference 26).

In addition to the cladding material thermal properties, the RETRAN Hot Spot Model incorporates numerous items which are a function of the fuel rod design. These include:

1. Fuel pellet diameter
2. Fuel rod cladding inner and outer diameter
3. Fuel rod pitch
4. Fraction of heat generated in fuel
5. Fuel melt temperature as a function of burnup
6. Initial fuel density (percent theoretical) and enrichment
7. Pellet-cladding gap initial gas composition and backfill pressure

Each of these items has been compared to determine whether the existing analysis parameter values for the NAIF design bound the features of the Mark-BW17 assemblies. This review has concluded that all key parameter values are either bounded by the NAIF design or are insignificantly different between the two fuel designs. The cladding temperature analysis results for the Locked Rotor and Rod Ejection events obtained for use of the NAIF design at North Anna will thus be conservative for the Mark-BW17 lead test assemblies.

6.4 Conclusions

A review of fuel design feature differences between the Mark-BW17 and resident NAIF designs has indicated that only a limited number of features used as key NSSF accident analysis inputs are different. Assessment of these specific differences for both events which have DNB and non-DNB acceptance criteria has concluded that the existing licensing analyses performed for the NAIF design will be applicable for the Mark-BW17 lead test assemblies in North Anna.

It should also be noted that there will only be four lead test assemblies with the Alloy 4 and Alloy 5 cladding materials, and that these fuel assemblies will not be placed in the highest fuel rod power density locations in the North Anna cores in which they are irradiated. This will further ensure the existence of margin to the safety analysis limits for these fuel assemblies. The conclusions of the North Anna analyses of record for the Chapter 15 non-LOCA accidents will remain valid for cores containing the four FCF lead test assemblies.

7. LOCA/ECCS Evaluation

The North Anna plants are fueled with North Anna Improved Fuel (NAIF) supplied by Westinghouse Electric Corporation. The NAIF fuel design is similar to and compatible with the Westinghouse VANTAGE 5H design. Compliance with 10 CFR 50.46 has been demonstrated by calculations performed by the Virginia Electric and Power Company using the Westinghouse NRC-approved evaluation model and methods, and documented in the North Anna Units 1 and 2 UFSAR (Reference 27). This section documents calculations performed by Framatome Technologies, Inc. (FTI) that demonstrate that the existing North Anna calculations based on the NAIF assemblies conservatively bound the LOCA performance of the Mark-BW17 lead test assemblies. Several confirmatory large break LOCA (LBLOCA) calculations were performed for the Mark-BW17 fuel design. The results demonstrate that the NAIF design, assuming operation under identical constraints, produces key results that bound those obtained for the Mark-BW17 fuel. Thus, the NAIF LBLOCA licensing record can serve to demonstrate that the Mark-BW17 lead test assemblies meet the criteria of 10 CFR 50.46. For the Small Break LOCA, compliance with 10 CFR 50.46 is shown by validating that the calculations performed in support of the NAIF design are wholly applicable to the Mark-BW17 test assemblies. This approach is possible because small breaks are plant system determinant and not dependant on fuel assembly design for reasonably equivalent designs. Thus, for the entire LOCA spectrum it is shown that the NAIF licensing calculations represent a conservative analysis for licensing the operation of the Mark-BW17 lead test assemblies.

7.1 Calculational Inputs and Assumptions

The LBLOCA analysis supporting the licensing of the lead test assemblies was performed in accordance with Revision 3 of the FTI recirculating steam generator LOCA evaluation model (Reference 28). The evaluation of cladding temperature transients and local oxidation used with three computer codes, interconnected as shown in Figure 7.1. The RELAP5/MOD2-B&W code calculates system thermal hydraulics and cladding temperature responses, including the hot channel, during blowdown. The thermal hydraulic transient calculations are continued within the REFLOD3B code to determine refill time and core reflooding rates. The BEACH code determines the hot pin cladding temperature response during refill and reflood.

7.1.1 Inputs and Assumptions

Because the purpose of the comparative LBLOCA calculations is to demonstrate that the NAIF licensing calculations for North Anna bound the results for the Mark-BW17 lead test assemblies, the major plant operating parameters used in the calculations correspond to those used in the NAIF calculations. The key parameters and their values, also summarized in Table 7.1, are:

1. Power Level - The plant is assumed to be operating in steady-state at 2951 MWT (102% of 2893 MWT).
2. Total System Flow - The initial RCS flow is 288,000 gpm.
3. Fuel Parameters - Studies discussed in Section 7.2.2 of this Safety Significance assessment show that fuel conditions at the beginning of life are the most severe for the LBLOCA evaluation of the Mark-BW17.
4. ECCS - The ECCS flows are based on the assumption of a single active failure that takes one complete train of ECCS out of service. This is the worst case assumption for the North Anna NAIF fuel LOCA calculations and is preserved in the Mark-BW17 comparative calculations.
5. A value of $F_Q = 2.19$ was used for the total peaking factor.
6. The Steam Generator tube plugging level was set at 7 percent per generator.
7. The FTI LOCA evaluation model does not require fixing or controlling the relationship between the axial and radial peaking factors. Under the FTI model, control of the maximum local heating rate is considered sufficient to assure a conservative prediction of peak cladding temperature. Furthermore, the model does not differentiate the hot pin from other pins in the hot assembly. Thus no separate F_{AH} value is employed. To make the comparison between the Virginia Electric and Power Company LOCA calculations and the Mark-BW17 calculations, the hot assembly radial peaking from the NAIF calculations was used with a revised axial peaking that would generate the total peak, i.e. preserve $F_Q = 2.19$. This provides a correspondence between the models that matches both the energy deposition to

the fluid cooling the hot pin and the maximum local power at the peak in the hot pin. Although FTI LOCA methods do not require control of bundle power or $F_{\Delta H}$, the Mark-BW17 assemblies will be controlled to the same criteria as the NAIF assemblies.

8. Because it is anticipated that the Mark-BW17 test assemblies will be irradiated in North Anna Unit 1, the calculations were performed for the upflow baffle gap configuration of North Anna 1 and the calculational results are compared to Virginia Electric and Power Company's NAIF calculations for this configuration. Should the assemblies be irradiated in North Anna Unit 2, which has a downflow baffle gap configuration, the differential peak clad temperature (ΔPCT) as calculated for the NAIF assemblies will be added to the temperature results for the Mark-BW17. This is appropriate because, as will be seen, the LOCA results for the assemblies are similar, with the NAIF results being slightly conservative.
9. The moderator density reactivity coefficient is based on beginning-of-cycle conditions to minimize negative reactivity.
10. Clad swelling and rupture is evaluated with the FTI RSG evaluation model rupture model for Zircaloy-4. The model is based on NUREG-0630 (Reference 29). Section 7.1.4 of this assessment presents justification for the application of this model to the advanced cladding material incorporated into the Mark-BW17 design.
11. Both the structural grids and the mid-span mixing grids (MSMGs) are explicitly modeled using the approach set forth in the FTI evaluation model.

7.1.2 RELAP5/MOD2-B&W and BEACH Modeling

The RELAP5/MOD2-B&W computer code is used to analyze RCS thermal hydraulic behavior and cladding temperature response during the blowdown phase of a LOCA. In its BEACH implementation, RELAP5/MOD2-B&W is also the hot channel calculation for refill and reflood. RELAP5/MOD2-B&W, a modified version of the RELAP5/MOD2 code, is documented in BAW-10164 (Reference 30). The BEACH implementation of RELAP5 is documented in BAW-10166 (Reference 31).

RELAP5 permits the user to select model representation that results in a suitable finite difference model for the fluid system being analyzed. Control volume inputs generally consist of geometry (area and height), flow-related parameters (resistance, hydraulic diameter, and surface roughness), and initial conditions (pressure, temperature, and flow). The non-equilibrium/non-homogeneous option is used throughout the model, except for the core region where the equilibrium/homogeneous option is selected because the core heat transfer package is based on such an assumption. Flow paths are defined between control volume geometric centers. The model is run in a steady-state mode to assure proper initialization.

BEACH and RELAP5/MOD2-B&W employ the same core model; BEACH is actually a restart of RELAP5 with controlled heat transfer logic and without the loop modeling. Two core nodalization schemes were used for the comparative calculations. The preliminary sensitivity studies, break

spectrum and burnup sensitivity were performed using a model that incorporated all features of the Mark-BW17 fuel assembly except the mid-span mixing grids (MSMGs). This lack of detail limits the application of the model for final predictions but does not compromise its application for determining sensitivity study trends. For the actual comparison runs used to confirm the applicability of the Virginia Electric and Power Company LOCA calculations and the North Anna operational limits to the Mark-BW17 assemblies, a spatially refined model which includes the MSMGs was used. The nodalization for the sensitivity studies is shown in Figures 7.2 and 7.3. The core node distribution is based on three nodes per grid span in accordance with Appendix C of the BEACH topical (Reference 31).

The core node distribution for the final comparison calculations adds more detail. The three node per grid span model remains but, with the addition of MSMGs after the fourth, fifth, and sixth structural grids, the total axial node count for the core increases to 29. The resulting arrangement is shown in Figure 7.4. The nodal length is defined so that each grid is located at or near the bottom of a node and three nodes are used to cover a grid span. This approach is used with both the structural and the mid-span mixing grids. Cross-flow is modeled at each axial elevation. The cross-flow resistance is kept at the value specified by the evaluation model but path areas are reduced to correspond to the new nodal heights.

Both of the FTI models simulated a full core of the Mark-BW17 fuel. Section 7.8 of this assessment discusses the application of the results within a core made up mostly of NAIF assemblies.

7.1.3 REFLOD3B Modeling

The REFLOD3B code simulates the thermal hydraulic behavior of the primary system during the core refill and reflood phases of the LOCA. The noding, shown in Figure 7.5, consists of reactor vessel and loop models. RELAP5 results at the end of blowdown (EOB) define the starting point for the REFLOD3B calculations. During the transient, the primary metal surface heat transfer coefficient for regions with flow is set to [] BTU/hr-ft²-°F, insuring that the fluid leaving the steam generator is continuously dry steam, superheated to the secondary side temperature. The pump rotor resistance is based on the locked rotor condition for the North Anna reactor coolant pumps (Westinghouse Model 93A pumps). A [] psi pressure drop is imposed on cold leg pipe junctions to account for momentum losses due to steam-ECC water interaction during the accumulator injection phase. This value is reduced to [] (pumped injection only) once the accumulators have fully discharged. The containment backpressures as a function of time from the North Anna UFSAR LBLOCA minimum containment pressure calculations are used in the REFLOD3B calculations. The use of UFSAR minimum containment pressure predictions has been employed in previous fuel reload licensing and is specifically approved within the FTI evaluation model.

7.1.4 Cladding Oxidation and Swelling and Rupture Models

As described in earlier sections, the Mark-BW17 fuel design incorporates two advanced cladding alloys designated as Alloy 4 and Alloy 5. These alloys do not fall within the Zircaloy specification, necessitating confirmation that certain Zircaloy-based LOCA fuel performance models can be

reasonably applied to the new materials. Validation was performed by Framatome for high temperature oxidation, cladding brittle fracture, and clad swelling and rupture modeling. Because Alloy 5 comprises the majority of the cladding in the lead test assemblies and because Alloy 4 closely parallels the Zircaloy-4 specification, the brittle fracture testing (cold water plunge tests) and the high temperature oxidation rate testing were conducted only for the Alloy 5 material. The results show that the Baker-Just oxidation correlation is conservative for the advanced zirconium alloys, that the oxidation limit for brittle fracture is the same for these alloys as for Zircaloy, and that the NUREG-0630 model can be applied for the prediction of cladding swelling and rupture.

Brittle Fracture and Oxidation Tests

High temperature oxidation performance for Alloy 4, Alloy 5 and Zircaloy can be expected to be similar because these alloys are predominantly zirconium and the oxidation of interest occurs after the change to the beta phase. For this reason, the early testing of the Alloy 5 high temperature oxidation rate was combined with the brittle fracture testing. Pressurized fuel pin samples were suspended above a cold water pool and heated in a steam environment until oxidations of 20 to 30 percent were achieved. The samples were then plunged into the water bath and quenched. The occurrence of brittle fracture is indicated if the sample can not continue to hold pressure during and after the quenching process. The temperature at which the oxidation took place was measured by optical devices and fed back to the heating mechanism, maintaining a constant temperature during oxidation.

Post-quench examination of the sample provides the oxidation thickness actually achieved during the testing. By comparing the time at temperature to the measured oxidation, the rate of oxidation can be determined. The results indicate that the rate of oxidation at high temperatures for Zircaloy and Alloy 5 are similar and that the advanced zirconium-based alloys are easily bounded by the Baker-Just correlation. Thus, the Baker-Just correlation can be conservatively applied for the computation of cladding oxidation as required by Appendix K of 10 CFR 50. The result of the quenching tests showed that the threshold for brittle fracture occurs at [] percent oxidation. NUREG/CR-1344 (Reference 32) indicates that the threshold for Zircaloy occurs at approximately 20 percent. Thus, the brittle fracture of the advanced alloy cladding material is no more likely than the fracture of Zircaloy provided the 17 percent local oxidation limit of 10 CFR 50.46 is met.

Cladding Swelling and Rupture Tests

The analyses performed to support the licensing of the Mark-BW17 lead test assemblies used the FTI implementation of the NUREG-0630 cladding swelling and rupture models. To demonstrate the applicability of these models, single-pin rupture tests were conducted at the French Government's EDGAR test facility. The requirement, as expressed in Appendix K, for clad swelling and rupture modeling is that "... the degree of swelling and the incidence of rupture are not underestimated." NUREG-0630 established models that meet these criteria for Zircaloy and thereby the degree of conformity required between the experimental result of rupture testing and the predictive capability of a rupture model. To date, the testing done on Alloy 4 and Alloy 5 shows that rupture test results lie within the dispersion of the NUREG-0630 experimental data base and can be expected to correlate equally well with the NUREG-0630 rupture models. Therefore, it is reasonable

to apply the NUREG-0630 rupture models within the LOCA models for the Mark-BW17 lead test assembly calculations.

The EDGAR test facility is comprised of a tank within which a pressurized tubing sample can be heated at various rates until rupture occurs. A schematic of the test facility is shown in Figure 7.6. Both creep and ramp testing have been conducted for the advanced alloy materials. Creep results, however, are only of limited interest in generating LOCA models because ruptures occur within ramps during LOCA. Further, for the North Anna LOCA transients (see Section 7.3 of this assessment), rupture occurs during reflood and the cladding heatup rate is limited to approximately 20°F (10 to 12°C) per second. Therefore, the slow ramp correlations and supporting data from NUREG-0630 are of the most interest in determining the applicability of the model to the Alloy 4 and Alloy 5 material. Figures 7.7 and 7.8 show the results of four Alloy 5 tests done at a ramp rate of 10°C/sec in comparison with the NUREG-0630 data base and the NUREG-0630 slow ramp correlations (heating rates of 9 to 11°C/sec).

As can be seen in the figures, the data lies within the span of dispersion of the data upon which the NUREG-0630 models were based. As shown in Figure 7.7, the Alloy 5 rupture temperature versus stress results follow the general trend of the NUREG-0630 data base and correlation. Figure 7.8 shows wide dispersion in the cladding strain data for Zircaloy. The dispersion is due to a variety of differences in the actual testing, but mainly to the stochastic nature of the phenomena being tested. As with the rupture stresses, the Alloy 5 strain results fit within the experimental data base for the NUREG-0630 correlations. The results of preliminary rupture testing on Alloy 4, not shown, also fit within the data result range upon which the NUREG-0630 correlations were based. The overall conclusion is that the NUREG-0630 models fit or bound the cladding swelling and rupture characteristics expected for the Alloy 4 and Alloy 5 materials. It is therefore justifiable to apply the NUREG-0630 models to the analysis of the LOCA performance of the Mark-BW17 lead test assemblies for North Anna.

7.2 Sensitivity Studies

Although a considerable portion of the analysis inputs and assumptions for the North Anna lead test assemblies are set by the FTI evaluation model, some parameters are dependent on plant-specific or fuel design values. Two sensitivity studies were performed for the Mark-BW17 calculations in order to assure a proper comparison between the FTI evaluation model predictions and the Virginia Electric and Power Company NAIF calculations. A break size spectrum was run to assure that the worst case break for the FTI evaluation model was used in the comparative cases, and a burnup study was conducted to assure that the calculations for the Mark-BW17 were done at the most limiting time in life. The core power distribution selected for these studies was peaked near the center of the core. The vessel modeling used is depicted in Figure 7.3.

7.2.1 Break Spectrum Analysis

A discharge coefficient study, with coefficients of 1.0, 0.8, 0.6, and 0.4, was conducted for a guillotine break of twice the piping area and located in the pump discharge piping. Table 7.2 provides the results of the study. Although there was very little difference in the results from one

case to another, the worst case was identified as the 0.6 discharge coefficient. Parameters of interest for the worst case are shown in Figures 7.9 through 7.13. Figure 7.14 compares the peak cladding temperature response for each discharge coefficient case. There are no major differences among the sequences of events for the four cases that make up the discharge coefficient study. Table 7.3 presents the sequence of events for the $C_d = 0.6$ case.

As shown in Table 7.2, the peak cladding temperatures differ by less than 65°F. This result is expected and consistent with the application of the FTI evaluation model to other plant types. Although the differences in cladding temperature response are small, the C_d of 0.6 has been incorporated as the worst case within the remainder of the FTI calculations and will be the case compared to the NAIF worst case calculation. For the Virginia Electric and Power Company NAIF calculations, the C_d of 0.4 was identified as the worst case.

7.2.2 Time in Life Study

Burnup sensitivity studies are conducted for the purpose of determining if the combination of initial fuel stored energy and initial internal fuel pin pressure selected for the LOCA evaluation comprise a worst case combination. Based on generic sensitivity studies (Reference 28), the FTI evaluation model concludes that the worst case combination will be that with the highest initial fuel stored energy so long as no other combination of conditions can lead to a cladding rupture during blowdown. Although the creep performance of the advanced cladding materials used in the Mark-BW17 lead test assemblies differs from that of Zircaloy, the highest fuel stored energy still occurs at beginning-of-life conditions. However, it is not obvious from inspection of the initial fuel conditions as functions of burnup that an irradiated condition will not lead to a fuel cladding rupture during blowdown. Therefore, a separate blowdown calculation was performed using the end-of-life fuel stored energy and internal pin pressure. The result showed that no blowdown rupture would occur for the North Anna calculations. Therefore the beginning-of-life fuel temperatures and internal pin pressures are used for the comparative calculations.

7.3 Comparison Calculation Results and Verification of K_z Curve

Typically the LOCA evaluation is completed with a set of analyses to show compliance with 10 CFR 50.46 for the core power and peaking that will limit plant operation. For the comparative analyses, this entails a demonstration of the Mark-BW17 LOCA performance for the K_z and F_Q combination approved for the NAIF fuel. To accomplish the K_z validation and to demonstrate that the NAIF calculations provide a conservative bound for the Mark-BW17 LOCA performance, analyses were conducted for three different axial power shapes. The results of these calculations are presented below and compared with the NAIF worst case calculation results.

Figure 7.15 shows the axial distribution of normalized power peaking applicable to the North Anna plants. To determine the applicability of Figure 7.15 to the Mark-BW17 lead test assemblies and determine a worst case power distribution from the distributions allowed by Figure 7.15, the LBLOCA results for three different axial distributions were calculated. For full applications of the FTI LBLOCA evaluation model (Reference 28), five core elevations would have been calculated. However, for this application, where a K_z distribution is already established, it is necessary only to

demonstrate that the worst case can be confirmed for the approved K_z distribution. The Westinghouse evaluation model, used by the Virginia Electric and Power Company, demonstrates that the 6 foot peak is the worst case so long as the K_z of Figure 7.15 is applied. Through calculation of a 4.6, 6.7, and 10.1 foot peak with the FTI model, the worst case for the Mark-BW17 lead test assemblies is established as an axial power shape peaked near the 6 foot elevation. A comparison of the FTI worst case to the NAIF worst case shows that the Virginia Electric and Power Company K_z curve is appropriate for the Mark-BW17 design and that the NAIF calculation results are comparable to, and slightly bound, the Mark-BW17 results.

The calculations were performed using the core model depicted in Figure 7.4 which incorporates the MSMGs. Figure 7.16 shows the power shape for each of the runs. Even though K_z has decreased slightly by the 6.7 foot level, both the 4.6 foot and the 6.7 foot peaks used an F_Q of 2.19. For the case with an axial peak at 10.1 feet the F_Q was reduced in accordance with K_z to a value of 2.08. The results of the calculations are tabulated in Table 7.4. The worst case PCT, 1966°F, is for the peak at 6.7 feet. The 4.6 foot peak is somewhat lower, 1935°F, because of its proximity to the advancing quench front. The 10.1 foot elevation produces a lower cladding temperature because of the reduced F_Q , 2.08, and because the MSMGs are fully effective at this elevation. Figures 7.17 through 7.19 show the key parameters for the 6.7 foot peaked case. Figure 7.20 displays the cladding temperature responses versus time for the three separate axial power distribution cases.

7.4 Mark-BW17 Compliance with 10 CFR 50.46

Peak Cladding Temperature

The worst case LOCA result published for North Anna, 2013°F, is for a 6 foot axial peak. However, that result is for a downflow baffle gap configuration which is representative of North Anna Unit 2. The comparative case result for the upflow configuration at North Anna Unit 1 is 1975°F. This would compare to the 6.7 foot result of 1966°F for the Mark-BW17 lead test assemblies. Table 7.5 presents a comparison of key results from the Virginia Electric and Power Company NAIF calculations and the FTI Mark-BW17 calculations for both North Anna units. The results are essentially the same with the NAIF results providing a slight bound of the cladding temperatures expected for the Mark-BW17 fuel. This means that evaluations of the NAIF can be conservatively applied to the Mark-BW17 lead test assemblies so long as the operating conditions for the Mark-BW17 assemblies are limited in the same fashion as for the NAIF assemblies. Because the two fuel assembly designs will be operated under the same Technical Specification limits and operating constraints, the North Anna licensing calculations for the NAIF assemblies can be applied to the licensing of the Mark-BW17 lead test assemblies and supply the necessary demonstration of compliance with the criteria of 10 CFR 50.46.

Local Cladding Oxidation

Table 7.5 compares the amount of local oxidation between the Virginia Electric and Power Company calculations and the Mark-BW17 results for the centrally peaked power distribution cases. The FTI results show a maximum oxidation of 3.5 percent and the NAIF results show a maximum of 4.5 percent oxidation. The most severe local oxidation for the Mark-BW17 fuel, 4.7 percent, occurs

when the core power is peaked at 10.1 feet (see Table 7.4). This value is slightly higher (0.2 percent) than the maximum oxidation for the NAIF assemblies. However, the results are all well below the 17 percent criterion of 10 CFR 50.46, assuring that assemblies of both designs are in compliance with this criterion.

Maximum Hydrogen Generation

The North Anna calculation for core wide oxidation and hydrogen generation will not change because of the inclusion of four FCF supplied lead test assemblies regardless of the assemblies' LOCA performance. Additionally, a comparison between the calculated results for the Mark-BW17 and the NAIF fuel designs shows that the peak local oxidation for the NAIF is comparable to that for the Mark-BW17. Therefore, the prediction of acceptable core wide oxidation for the full NAIF core also demonstrates that North Anna cores with the four FCF-supplied lead test assemblies will also meet this 10 CFR 50.46 criterion.

Coolable Geometry

The fourth acceptance criterion of 10 CFR 50.46 states that calculated changes in core geometry shall be such that the core remains amenable to cooling. The calculations in Section 7.3 of this assessment directly address the alterations in geometry for the Mark-BW17 that result from the worst case LOCA. These calculations demonstrate that the fuel pin is cooled successfully. As discussed in Section 7 of the FTI evaluation model report (Reference 28), clad swelling and flow blockage due to rupture can be estimated based on NUREG-0630. For the Mark-BW17 calculations, the hot assembly flow area reduction at rupture is less than 40 percent. Furthermore, the upper limit of possible channel blockage, based on NUREG-0630, is less than 90 percent. Neither 90 percent blockage nor 40 percent blockage constitutes total subchannel obstruction. Since the position of rupture in a fuel assembly is distributed within the upper part of a grid span, subchannel blockage will not become coplanar across the assembly. Therefore, the assembly retains its pin coolant-channel pin coolant-channel arrangement and is capable of passing coolant along the pin to provide cooling for all regions of the assembly.

The effects of fuel rod bowing on whole-core blockage are considered in the FCF fuel assembly and fuel rod designs in such a way as to minimize the potential for rod bowing. Minor adjustments of fuel pin pitch due to rod bow do not substantially alter the fuel assembly flow area and the average subchannel flow area within an assembly is preserved. Therefore, due to the axial distribution of blockage caused by rupture, no coplanar blockage of the fuel assembly will occur and the core will remain amenable to cooling. Effects upon the fuel pin lattice from the combined mechanical loadings of the LOCA and a seismic event have been calculated separately for the Mark-BW17 design. The loadings remain within the Mark-BW17 elastic limits regardless of the core locations for the lead test assemblies. Therefore, there is no permanent deformation of the Mark-BW17 fuel for combined LOCA and seismic loads.

The consequences of both thermal and mechanical deformation of the Mark-BW17 lead test assemblies in the North Anna core have been assessed and the resultant deformations have been shown to maintain coolable core configurations. Therefore, the coolable geometry requirements of

10 CFR 50.46 have been met for the Mark-BW17 assemblies and the assemblies have been shown to remain amenable to core cooling following a LOCA.

Long-Term Cooling

The fifth acceptance criterion of 10 CFR 50.46 states that the calculated core temperature shall be maintained at an acceptably low value and decay heat shall be removed for the extended period of time required by the long-lived radioactivity remaining in the core. This criterion is a system level criterion and independent of the fuel design. There have been no system level changes introduced with this reload that would alter the long-term cooling process. Therefore, the calculations and arguments presented to license North Anna remain valid with four FCF-supplied Mark-BW17 fuel assemblies operational in the core.

7.5 Small Break LOCA

The current licensing bases for North Anna comprise a spectrum of large and small break loss-of-coolant accidents (LOCAs) analyzed by Virginia Electric and Power Company and documented in updated final safety analysis report (UFSAR). For operation of North Anna with four FCF lead test assemblies, FTI has reanalyzed part of the large break LOCA transients as presented in the foregoing sections. Reanalysis of the small break LOCA for operation with FCF test fuel assemblies is not required since SBLOCA evaluations are unaffected by the design differences between the Mark-BW17 and the Westinghouse fuel assemblies. Thus, the reference UFSAR analyses remain the bases for plant licensing and become the basis for licensing use of the Mark-BW17 lead test assemblies in North Anna.

Fuel assembly design influences the SBLOCA calculations only to the extent that it affects overall system behavior. In that regard, differences between the Mark-BW17 fuel assemblies and the resident NAIF assemblies should not materially affect the bounding SBLOCA sequences of the reference UFSAR. The FCF lead test assemblies and resident Westinghouse assemblies differ in the following areas: unrecoverable pressure drops across the assemblies, initial fuel temperatures, and initial pin internal gas pressure.

The Mark-BW17 fuel assemblies have unrecoverable pressure drops that are approximately [] higher than those of the NAIF assemblies at the North Anna design flow. The inclusion of four of these assemblies within the core will not affect the overall loop or core pressure drop. Thus, the initial subcooled depressurization phase of the SBLOCA will be unaltered. The reactor trip signal and pump trips will occur at the same time in the transient as in the reference UFSAR calculations. For the same reason the pump coastdown and natural circulation phases will be unaffected. The CHF performance of the Mark-BW17 fuel design exceeds that of the NAIF assemblies due to the inclusion of the mid-span mixing grids. Thus, core resistance variations will not change the fuel thermal transient or impact existing evaluations.

Changes in the initial fuel temperature add or subtract overall energy from the RCS. However, the inclusion of only four assemblies will not alter the fuel energy removed from the reactor coolant system during the reactor coolant pump coastdown phase. Because all of the initial fuel pin energy

is transferred from the fuel pin during the early phases of the SBLOCA transient, the initial fuel enthalpy at operation has virtually no impact beyond the loop coastdown period. The core energy content during loop draining and core boildown will be identical to the current licensing base because it is solely dependant on the decay heating rate.

The fuel pin internal fill gas pressure for the Mark-BW17 lead test assemblies is lower than that for the resident NAIF assemblies. The difference will result in lower internal pressure both initially and during the LOCA transient. This will lead to a rupture of the Mark-BW17 fuel assembly at a somewhat later time than would occur for the Westinghouse fuel. An alteration of rupture timing can affect the result of a small break LOCA calculation if it is possible for rupture to occur at very high temperatures. At temperatures approaching 2000°F, the oxidation rate of unoxidized cladding is significant. If the fuel pin ruptures at these temperatures, the oxidation on the inside of the cladding will drive the cladding temperature significantly higher. This is not a concern at North Anna because the peak SBLOCA cladding temperature is approximately 1700°F and there is, thus, no possibility of a fuel pin even getting to the 2000°F range. Other than the possibility for high temperature rupture, the effects of rupture and rupture timing on SBLOCA are benign and not of concern for LOCA calculational results.

As a final point, the Technical Specifications for allowable local power levels, core peaking, for core elevations at or above 6 feet will not be changed due to the inclusion of the four FCF lead test assemblies. Thus, the axial power profile used by Virginia Electric and Power Company in the current SBLOCA analyses remains bounding. This assures that the thermal power imposed on the fuel during a temperature excursion remains conservatively modeled. The cladding temperature results for the current UFSAR evaluations are, therefore, conservative for the Mark-BW17 lead test assemblies.

In summary, the core resistance variations will not affect the system flows such that the controlling hot leg temperature or CHF points are altered. The steam generator heat removal rate during the flow coastdown period will compensate for any initial fuel stored energy fluctuations. All but one controlling parameter in the phases following the pump coastdown and natural circulation phase will be unchanged and that one, rupture timing, does not affect the North Anna SBLOCA cladding temperature prediction. Since the overall RCS geometry, initial operating conditions, licensed power, and governing phenomena are effectively unchanged, the existing UFSAR calculations remain bounding for operation of North Anna with four FCF-supplied Mark-BW17 lead test assemblies. Therefore, the present SBLOCA evaluation calculations are applicable to the Mark-BW17 fuel for demonstrating compliance with the criteria of 10 CFR 50.46.

7.6 Mixed Core Considerations

The Mark-BW17 test assemblies will reside in a mixed core configuration with the NAIF assemblies throughout their irradiation. The LOCA analyses in support of the Mark-BW17 lead test assemblies have been performed assuming that the entire core is comprised of Mark-BW17 assemblies. This standard FTI approach for reload fuel licensing calculations provides an adequate evaluation of the fuel in both the mixed and unmixed core configurations.

Differences between the mixed and pure core conditions arise because of the different pressure drops of the two fuel assembly designs. At the North Anna design flow, the Mark-BW17 design has approximately a [] higher pressure drop than does the NAIF assembly. Thus, flow can be expected to divert slightly from the Mark-BW17 to the NAIF assemblies. Such differences are involved in most reload analyses where the utility has switched fuel suppliers. Studies performed by FTI for other utility transitions from Westinghouse fuel to FCF-supplied fuel have shown that the effects of reasonable fuel assembly pressure drop differences on cladding temperatures during blowdown and reflood counterbalance each other, resulting in comparable peak cladding temperature predictions between the LOCA results of mixed and pure core configurations.

For North Anna specifically, with only 4 of the 157 fuel assemblies in the core being of the Mark-BW17 design, there will not be sufficient diversion potential to affect the current LOCA calculations based on NAIF assemblies. The effects that would be imposed on the Mark-BW17 calculations by direct representation of the mixed core configuration are:

- (1) Some flow will divert to the NAIF assemblies during blowdown resulting in a slight increase in the predicted cladding temperature at the end of blowdown, and
- (2) The core reflooding rate, being controlled by the average channel flow resistance, will be increased above the reference Mark-BW17 calculation resulting in better reflood cooling.

Because peak cladding temperatures occur at extended times during reflood, the reflooding rate improvement is likely to be dominant. However, the two effects essentially trade off against each other making the reference calculations appropriate for either a mixed or full core condition.

Therefore, the pure core calculations performed to support either the Mark-BW17 or the NAIF remain valid during the mixed core configuration. The licensing position for the Mark-BW17, that the calculations done for the NAIF assemblies bound the Mark-BW17 assemblies and can be used for licensing the Mark-BW17 test assemblies, is valid for mixed core configurations.

7.7 LOCA/ECCS Summary and Conclusion

Calculations have been performed to demonstrate the LOCA performance of the Mark-BW17 lead test fuel assemblies in North Anna Unit 1 or 2. The calculations, performed with the NRC-approved FTI LOCA evaluation model, and the other supportive material referenced demonstrate that the five criteria of 10 CFR 50.46 are met. Specifically, it has been shown that for the operation of North Anna Unit 1 or 2 with four FCF Mark-BW17 lead test assemblies:

1. The calculated peak cladding temperatures for the limiting cases are less than 2200°F.
2. The maximum calculated local cladding oxidation is less than 17.0 %.
3. The maximum amount of core-wide oxidation does not exceed 1.0 % of the fuel cladding.

4. The cladding remains amenable to cooling.
5. Long-term cooling is established and maintained after the LOCA.

Further, it has been demonstrated that the existing Virginia Electric and Power Company calculations for the NAIF assemblies produce results which are comparable to and which slightly bound the FTI results for the Mark-BW17 lead test assemblies. This allows the licensing calculation for the NAIF assemblies, in conjunction with the calculations documented herein, to serve as the licensing basis for the Mark-BW17 lead test assemblies in North Anna. Therefore, if in the future, additional LOCA calculational justification is required for North Anna, in most cases it will be sufficient for Virginia Electric and Power Company to perform those calculations only on the NAIF assemblies using the Westinghouse evaluation model.

8. Applicability of Standard Reload Design Methodology

Virginia Electric and Power Company performs a reload safety evaluation using a bounding analysis method as described in Topical Report VEP-FRD-42 Rev. 1-A (Reference 3). This methodology defines a set of key analysis parameters that fully describe a valid conservative safety analysis ("reference analysis"). If all key analysis parameters for a reload core are conservatively bounded by the corresponding parameters in the reference analysis, the reference safety analysis is bounding, and further evaluation is not necessary. When a key analysis parameter is not bounded, further review is considered necessary to ensure that the required safety margin is maintained. This last determination is made through either a complete reanalysis of the accident, or through a simpler, though conservative, evaluation process using known parameter sensitivities.

The NRC Safety Evaluation Report (SER) approving use of the normal reload nuclear design methodology in Reference 3 concludes that the report is "...acceptable for referencing by Virginia Power in licensing Westinghouse supplied reloads of Westinghouse supplied reactors." At least two additional statements in the summary of the NRC's evaluation of the report also specifically confine the applicability of this methodology to only Westinghouse fuel. Other than noting the similarity of our methodology to that of our current fuel vendor, no specific details are presented to clarify what concerns the NRC may have regarding application of our current reload methodology to fuel supplied by other vendors. No similar statements are found in the SERs for our topical reports on specific analytical models or methods.

Virginia Electric and Power Company recognizes that fuel products supplied by different vendors could conceivably differ dramatically in design from our current fuel. In such a case, it would be desirable to benchmark our models and methods to either actual irradiation data or to the new fuel supplier's approved models. Such benchmarking would demonstrate that we can accurately predict the behavior of the new fuel design, and ensure that its predicted behavior can be satisfactorily incorporated into both reload design and conservative accident analyses. This is particularly important when full reloads of the new design are to be implemented, where the presence of the new fuel design can have a significant effect on the performance of the fuel remaining in the core, and where use of the new design may require new limits for accident analyses.

The lead test assembly program at North Anna, while using fuel assemblies provided by a new fuel vendor, will not result in a significant change to the North Anna cores. Several factors support this conclusion, including: similarity of the Mark-BW17 fuel design to the resident Westinghouse fuel, use of a limited number (four) of the FCF fuel assemblies, and exclusion of these assemblies from core locations where they would experience the highest fuel rod power density to ensure that existing safety analyses remain applicable.

The North Anna lead test assembly fuel design (FCF's Mark-BW17 design) is an extension of FCF's Mark-BW fuel design, which was designed specifically for use in Westinghouse units and for compatibility with the resident fuel in those units. The physical dimensions of this fuel are very similar to those of Westinghouse fuel, particularly the older Westinghouse LOPAR (Inconel grid) design, as can be seen from Tables 3.1 and 3.2. The assembly envelope and fuel rod pitch within the envelope are comparable for the FCF and Westinghouse designs. Individual fuel rod dimensions (including fuel stack length, fuel pellet diameter, pellet-to-clad gap size, and clad thickness) as well as guide thimble dimensions are comparable to the Westinghouse fuel used in North Anna. Evaluations of the mechanical fuel performance are performed by the fuel vendor (FCF for the lead test assemblies, and Westinghouse for the normal reload fuel). The FCF evaluation for the lead test assemblies has also addressed compatibility with the resident Westinghouse fuel.

Physical differences in the lead test assembly design that could affect core reload neutronic calculations such as the slightly higher uranium loading, the chemical composition of the cladding, and the presence of additional material in the active fuel regions (the mid-span mixing grids) can be easily incorporated into our core design models. Past changes made to the model inputs to incorporate neutronic significant changes to the Westinghouse fuel designs have resulted in fully acceptable predicted-to-measured power distributions and reactivity parameter agreement. Changes to the neutronic model inputs necessary to model the physical differences between the lead test assemblies and the resident Westinghouse fuel assemblies are similar to those used for previous Westinghouse fuel product changes, and are of a smaller magnitude than was necessary for many of the Westinghouse fuel product changes. With only four FCF lead test assemblies in use at North Anna, there will be a very limited impact on the overall core performance, with only a minor effect on core depletion, core reactivity parameters, or core reactivity control.

Thermal hydraulic analyses of the lead test assemblies were performed by FCF using their NRC-approved models and methods. It was determined that use of the four Mark-BW17 lead test assemblies will have a negligible impact on core thermal hydraulic evaluations, and that North Anna cores containing these assemblies can conservatively be modeled as a homogeneous core of Westinghouse fuel. Therefore use of these lead test assemblies will have no impact on Virginia Electric and Power Company's standard reload thermal hydraulic evaluations.

There are no differences between the FCF and Westinghouse fuel designs that would result in a different set of key analysis parameters than those already defined for the current safety analyses (Reference 3). Sensitivity of core transients to changes in the key analysis parameters will remain the same for the FCF fuel design due to the small difference from the Westinghouse fuel design. The impact of the lead test assembly design on both LOCA and non-LOCA accident analyses has been considered, by Framatome Technologies Inc. (FTI) and by Virginia Electric and Power Company

using appropriate input provided by FCF, respectively. The analyses of record, which are based on the Westinghouse fuel design, will remain applicable for the lead test assemblies. Cycle specific evaluation will continue to verify that the assumed values for any key analysis parameters are not exceeded for cycles in which the lead test assemblies are irradiated. There are no differences between the Mark-BW17 and Westinghouse fuel designs that could result in new failure mechanisms, that would increase the consequences of previously considered accident scenarios, or that would interfere with safe operation of the core. Therefore, incorporation of these assemblies into North Anna cores will not affect the ability of our current reload methodology to conservatively assess the core response to accident scenarios.

9. Assessment of Unreviewed Safety Question

The four FCF Mark-BW17 lead test assemblies are very similar in design to, and will exhibit performance comparable to, the resident Westinghouse fuel assemblies at North Anna. There will be no reduction in the design margin of safety. It is concluded that neither the use of the four FCF Mark-BW17 lead test assemblies at North Anna, nor the use of Virginia Electric and Power Company's standard reload design methodology to evaluate cores in which these assemblies are irradiated, results in the acceptable safety limits for any incident being exceeded or in any unreviewed safety questions as defined by 10 CFR 50.59 (a)(2). The basis for this determination is delineated below.

9.1 Probability of Previously Evaluated Accidents

This safety significance assessment documents that the probability of an accident previously evaluated in the North Anna Units 1 and 2 UFSAR is not increased. The designs for cycles at both units which incorporate the lead test assemblies will meet all applicable design criteria and ensure that all pertinent licensing basis acceptance criteria are met. The demonstrated adherence of the fuel and core designs to applicable standards and acceptance criteria precludes new challenges to components and systems that could increase the probability of occurrence of any previously evaluated accident. Specifically, neither the use of FCF fuel assemblies (with mid-span mixing grids and small mechanical design differences from the resident fuel) nor the use of fuel rods [] fabricated from the advanced zirconium-based alloys (Alloy 4 and Alloy 5), will increase the probability of occurrence of an accident previously evaluated in the North Anna Units 1 and 2 UFSAR. The FCF fuel assembly design is mechanically and neutronically very similar to that of the resident fuel. The advanced alloys improve corrosion performance, while the mid-span mixing grids provide additional DNB margin. The use of the four lead test assemblies will not cause the core to operate in excess of pertinent design basis operating limits. Therefore, the probability of occurrence of an accident previously evaluated in the UFSAR has not increased.

9.2 Consequences of Previously Evaluated Accidents

This safety significance assessment documents that the consequences of an accident previously evaluated in the North Anna Units 1 and 2 UFSAR are not increased. The reload core design for cycles which incorporate the lead test assemblies will meet all applicable design criteria and ensure

that all pertinent licensing basis acceptance criteria are met. The demonstrated adherence to these standards and criteria precludes new challenges to components and systems that could (a) adversely affect the ability of existing components and systems to mitigate the consequences of any accident, and/or (b) adversely affect the integrity of the fuel rod cladding as a fission product barrier. Furthermore, adherence to applicable standards and criteria ensures that these fission product barriers maintain design margin to safety limits. Specifically, safety analyses based on the resident fuel design will remain applicable for cores which incorporate the four FCF lead test assemblies. Therefore the use of these assemblies will not increase the consequences of an accident previously evaluated in the North Anna Units 1 and 2 UFSAR. Similarly, the radiological consequences of accidents previously evaluated in the North Anna Units 1 and 2 UFSAR do not increase.

9.3 Possibility of Accidents Not Previously Evaluated

This safety significance assessment documents that the possibility of an accident which is different from any already in the North Anna Units 1 and 2 UFSAR is not created. The FCF lead test assemblies are very similar in design to the resident Westinghouse fuel. Cores incorporating the lead test assemblies will meet all applicable design criteria and ensure that all pertinent licensing basis acceptance criteria are met. The demonstrated adherence to these standards and criteria precludes new challenges to components and systems that could introduce a new type of accident. Specifically, the design of cores which incorporate the FCF fuel assemblies using Virginia Electric and Power Company's standard reload design methodology will not create the possibility of an accident of a different type than any previously evaluated in the North Anna Units 1 and 2 UFSAR. Safety analyses based on the resident fuel design will remain applicable for cores which incorporate the four FCF lead test assemblies. No new single failure mechanisms have been created, nor will use of these assemblies cause the core to operate in excess of pertinent design basis operating limits. Therefore, the possibility of an accident of a different type than any previously evaluated in the UFSAR has not been created.

9.4 Probability of Previously Evaluated Malfunction of Equipment Important to Safety

This safety significance assessment documents that the probability of a malfunction of equipment important to safety previously evaluated in the North Anna Units 1 and 2 UFSAR is not increased. The design of cores which incorporate the lead test assemblies will meet all applicable design criteria and ensure that all pertinent licensing basis acceptance criteria are met. Demonstrated adherence to applicable standards and acceptance criteria precludes new challenges to components and systems that could increase the probability of any previously evaluated malfunction of equipment important to safety. Specifically, the use of FCF fuel assemblies with mid-span mixing grids, advanced zirconium-based alloys, and minor mechanical differences from the resident fuel will not increase the probability of occurrence of a malfunction of equipment important to safety previously evaluated in the North Anna Units 1 and 2 UFSAR. No new performance requirements are being imposed on any system or component such that any design criteria will be exceeded nor will the core be operated in excess of pertinent design basis operating limits. No new modes or limiting single failures have been created with the lead test assembly design. Safety analyses based on the resident Westinghouse fuel design will remain applicable for cores incorporating the lead test assemblies. Therefore, the probability of occurrence of a malfunction of equipment important to safety previously evaluated

in the UFSAR has not increased.

9.5 Consequences of Previously Evaluated Malfunction of Equipment Important to Safety

This safety significance assessment documents that the consequences of a malfunction of equipment important to safety previously evaluated in the North Anna Units 1 and 2 UFSAR are not increased. Cycle designs for cores which incorporate the lead test assemblies will meet all applicable design criteria and ensure that all pertinent licensing basis acceptance criteria are met. The demonstrated adherence to these standards and criteria precludes new challenges to components and systems that could adversely affect the ability of existing components and systems to mitigate the consequences of any accident. Furthermore, adherence to applicable standards and criteria ensures that these fission product barriers maintain the design margin of safety. Specifically, the use of four FCF Mark-BW17 lead test assemblies very similar in design to the Westinghouse fuel that comprises the remainder of the core will not increase the consequences of a malfunction of equipment important to safety previously identified in the North Anna Units 1 and 2 UFSAR. The use of these assemblies does not change the performance requirements on any system or component such that any design criteria will be exceeded and will not cause the core to operate in excess of pertinent design basis operating limits. No new modes or limiting single failures have been created with the Mark-BW17 fuel assembly design. Therefore, the consequences of a malfunction of equipment important to safety previously evaluated in the North Anna Units 1 and 2 UFSAR have not increased.

9.6 Possibility of Malfunction of Equipment Important to Safety Not Previously Evaluated

This safety significance assessment documents that the possibility of a malfunction of equipment important to safety different from any already evaluated in the North Anna Units 1 and 2 UFSAR is not created. The design for North Anna cycles which incorporate the four FCF lead test assemblies will meet all applicable design criteria and ensure that all pertinent licensing basis acceptance criteria are met. The demonstrated adherence to these standards and criteria precludes new challenges to components and systems that could introduce a new type of malfunction of equipment important to safety. Specifically, the use four FCF Mark-BW17 fuel assemblies that are very similar in design (both mechanical design and material composition) to the Westinghouse fuel assemblies that constitute the remainder of the core will not create the possibility of a malfunction of equipment important to safety of a different type than any previously evaluated in the North Anna Units 1 and 2 UFSAR. No new failure modes have been created for any system, component, or piece of equipment. No new single failure mechanisms have been introduced, nor will the core operate in excess of pertinent design basis operating limits. Therefore, the possibility of a malfunction of equipment important to safety of a different type than any previously evaluated in the UFSAR has not been created.

9.7 Margin of Safety

This safety significance assessment documents that the margin of safety as defined in the Bases to any North Anna Technical Specification is not reduced. Safety analyses which are based on full cores of Westinghouse fuel and which are supported by the applicable North Anna Unit 1 and North Anna Unit 2 Technical Specifications will remain applicable for North Anna cores incorporating the

four FCF lead test assemblies. The use of the four Mark-BW17 lead test assemblies will not reduce the margin of safety as defined in the basis for any Technical Specification. The use of these fuel assemblies will take into consideration the normal core operating conditions allowed in the Technical Specifications. For each cycle reload core, these fuel assemblies will be specifically evaluated using Virginia Electric and Power Company's standard reload design methods. This will include consideration of the core physics analysis peaking factors and core average linear heat rate effects. Therefore, the margin of safety as defined in the Bases to the North Anna Unit 1 and North Anna Unit 2 Technical Specifications has not been reduced.

10. Conclusions

The North Anna Units 1 and 2 Technical Specifications (References 7 and 8) ensure that the plants operate in a manner that provides acceptable levels of protection for the health and safety of the public. The Technical Specifications are based upon assumptions made in the safety and accident analyses, including those relating to the core design. This ensures adequate margin to the regulated acceptance criteria for the accident analyses. Since it has been concluded that the North Anna safety analyses which are based on full cores of Westinghouse fuel will remain applicable for cores which incorporate four FCF Mark-BW17 lead test assemblies, the conclusions in the North Anna Units 1 and 2 UFSAR (Reference 27) are valid. Therefore the regulated margin of safety as defined in the Bases of the Technical Specifications is not affected by the use of these lead test assemblies in North Anna Units 1 and 2.

Based on the evaluations and analysis results presented in the foregoing safety significance evaluation, it has been demonstrated that neither the use of the four FCF Mark-BW17 lead test assemblies at North Anna, nor the use of Virginia Electric and Power Company's standard reload design methodology to evaluate cores in which these assemblies are irradiated, results in the acceptable safety limits for any incident being exceeded or in any unreviewed safety questions as defined in 10 CFR 50.59.

SUMMARY

The foregoing analyses and evaluations demonstrate that the conclusions of the accident analyses in the North Anna Units 1 and 2 UFSAR remain applicable for the proposed use of the four Mark-BW17 lead test assemblies supplied by FCF. Each pertinent design and safety criterion was evaluated for the impact of both the material and mechanical design differences from the resident Westinghouse fuel, and the evaluation results were found to be acceptable. It has also been determined that the use of the lead test assemblies will not affect the ability of our standard reload design methodology to accurately assess the normal core performance nor affect our ability to conservatively model the core response to accident scenarios.

Table 2.1
Nominal Compositions (wt%) of
Zirconium-Based Alloys for North Anna Fuel

Element	Zircaloy-4	ZIRLO	Alloy 5	Alloy 4
Sn	1.45*	1.0	[]	[]
Fe	0.21	0.1		
Cr	0.1	—		
Nb	—	1.0		
V	—	—		
Zr	Balance	Balance		

- * This value represents the mid-point of the ASTM specification for tin in Zircaloy-4. Recent Zircaloy-4 cladding fabricated by both Westinghouse and FCF has been manufactured under tighter specifications on the concentration of tin to improve corrosion resistance. These low-tin materials still fall within the ASTM specification for Zircaloy-4.

Table 2.2
 Mechanical Properties of
 Alloy 4, Alloy 5 and FCF Zircaloy-4 Tubing

Tube Material Alloy	20°C			343°C			385°C		
	0.2% Y.S.	U.T.S.	% Elong	0.2% Y.S.	U.T.S.	% Elong	0.2% Y.S.	U.T.S.	% Elong
Alloy 5									
Specification criteria (ksi)									
(MPa)									
Typical values (ksi)									
(MPa)									
Alloy 4									
Specification criteria (ksi)									
(MPa)									
Typical values (ksi)									
(MPa)									
Zr-4 (recrystallized tube)									
Specification criteria (ksi)									
(MPa)									
(major diam.) Typical values (ksi)									
(MPa)									
Zr-4 (stress-relieved tube)									
Specification criteria (ksi)									
(MPa)									
Typical values (ksi)									
(MPa)									

Table 2.3
Alloy 5 and Alloy 4 Irradiation Experience

Alloy	Reactor	Number of Cycles	Burnup, GWD/MTU	Corrosion, μm
Alloy 5 (5R)	E1 E2 E3 US1			
Alloy 5 (M5)	E4 E5 E6			
Alloy 4	E1 E2 E3 US1			
FCF Zr-4 (low Sn)	(composite)			

- * Currently in 4th cycle with expected burnup of 50 GWD/MTU in 1996
- ** Currently in 5th cycle with expected burnup of 55 GWD/MTU in 1997

Table 3.1
Comparison of BOL Nominal Grid Elevations
for Lead Test Assemblies and North Anna Resident Fuel Types

	<u>Mark- BW17</u>	<u>W LOPAR</u>	<u>NAIF- Zircaloy</u>	<u>NAIF- ZIRLO</u>
Top Nozzle		<u>159.915</u>	<u>159.975</u>	<u>159.775</u>
Top End		<u>153.60</u>	<u>153.60</u>	<u>153.40</u>
Inter Grid 6		<u>133.01</u>	<u>133.10</u>	<u>133.10</u>
MSMG 3		<u>N/A</u>	<u>N/A</u>	<u>N/A</u>
Inter Grid 5		<u>112.46</u>	<u>112.55</u>	<u>112.55</u>
MSMG 2		<u>N/A</u>	<u>N/A</u>	<u>N/A</u>
Inter Grid 4		<u>91.91</u>	<u>92.00</u>	<u>92.00</u>
MSMG 1		<u>N/A</u>	<u>N/A</u>	<u>N/A</u>
Inter Grid 3		<u>71.36</u>	<u>71.45</u>	<u>71.45</u>
Inter Grid 2		<u>50.81</u>	<u>50.90</u>	<u>50.90</u>
Inter Grid 1		<u>30.26</u>	<u>30.35</u>	<u>29.70</u>
Btm End		<u>5.835</u>	<u>5.835</u>	<u>6.535</u>
Prot Grid		<u>N/A</u>	<u>N/A</u>	<u>3.093</u>
Btm Nozzle		<u>2.383</u>	<u>2.383</u>	<u>2.383</u>
		<u>0.0</u>	<u>0.0</u>	<u>0.0</u>

Distances are from bottom of bottom nozzle to top of grid assembly inner strap, in inches.

Table 3.2
Comparison of Mark-BW17 and
Resident North Anna Fuel Designs

Parameter	FCF Mark-BW17 Fuel Assembly	W LOPAR Fuel Assembly	W NAIF Fuel Assembly	W NAIF Fuel w/ ZIRLO
Fuel Assembly Length, in.		159.915	159.975	159.775
Assembly Envelope, in.				
Top Nozzle		8.405	8.400	8.400
End Grids		8.426	8.426	8.426
Intermediate Grids		8.417	8.418	8.418
MSMGs		-	-	-
Bottom Nozzle		8.426	8.425	8.426
Fuel Rods				
Number of Fuel Rods/Assy		264	264	264
Active Fuel Length, in.		144.0	144.0	144.0
Fuel Rod Pitch, in.		0.496	0.496	0.496
Fuel Clad Material		Zircaloy-4	Zircaloy-4	ZIRLO
Fuel Rod Clad O.D., in.		0.374	0.374	0.374
Fuel Rod Clad Thickness, in.		0.0225	0.0225	0.0225
Fuel Pellet Diameter, in.		0.3225	0.3225	0.3225
Fuel Pellet Density, % TD		95	95	95
Fuel Pellet Length, in.		0.387	0.387	0.387
Effective Dish, Percent		1.207	1.207	1.207
Guide Thimbles				
Number of GTs/Assy		24	24	24
Guide Thimble Material		Zircaloy-4	Zircaloy-4	ZIRLO
GT Length (incl. End Plug)		153.10	153.215	153.015
Upper Portion				
Length to mid-transition, in.		129.160	129.275	129.075
Outer Diameter, in.		0.482	0.474	0.474
Inside Diameter, in.		0.450	0.442	0.442

Table 3.2
Comparison of Mark-BW17 and
Resident North Anna Fuel Designs

Parameter	FCF Mark-BW17 Fuel Assembly	W LOPAR Fuel Assembly	W NAIF Fuel Assembly	W NAIF Fuel w/ ZIRLO
Lower Portion				
Length to mid-transition, in.		23.940	23.940	23.940
Outer Diameter, in.		0.430	0.430	0.430
Inside Diameter, in.		0.397	0.397	0.397
Instrumentation Tube				
Number/Assembly		1	1	1
Instrumentation Tube Material		Zircaloy-4	Zircaloy-4	ZIRLO
Instrumentation Tube O.D, in.		0.482	0.474	0.474
Instrument Tube I.D., in.		0.450	0.442	0.442
Spacer Grid				
Axial Positioning		Table 5.1	Table 5.1	Table 5.1
Top and Bottom End Grids				
Grid Material		Inconel 718	Inconel 718	Inconel 718
Grid Sleeve Material		304 SS	304 SS	304 SS
Strip Width (Height), in.		1.322	1.522	1.522
Intermediate Grids				
Grid Material		Inconel 718	Zircaloy-4	ZIRLO
Grid Sleeve Material		304 SS	Zircaloy-4	ZIRLO
Strap Width (Height), in.		1.322	1.500	1.500
Mid-Span Mixing Grids				
Grid Material		N/A	N/A	N/A
Grid Sleeve Material		N/A	N/A	N/A
Strap Width (Height), in.		N/A	N/A	N/A

Table 3.2
 Comparison of Mark-BW17 and
 Resident North Anna Fuel Designs

Parameter	FCF Mark-BW17 Fuel Assembly	W LOPAR Fuel Assembly	W NAIF Fuel Assembly	W NAIF Fuel w/ ZIRLO
Protective Grid				
Grid Material	[REDACTED]	N/A	N/A	Inconel 718
Grid Sleeve Material		N/A	N/A	304 SS
Strap Width (Height), in.		N/A	N/A	0.690
Top Nozzle Holddown Spring				
Type		3 Leaf	3 Leaf	3 Leaf
Spring Material		Inconel 718	Inconel 718	Inconel 718

Table 4.1
Parameter Ranges & Uncertainties used for SDL Determination

Parameter Ranges for SDL Determination

Variable	Range
Core Power	70% to 130%
Core Flow	65% to 125%
Core Pressure	1800 to 2600 psia
Core Inlet Subcooling	40°F to 110°F
Radial Power Factor ($F_{\Delta H}$)	1.1 to 1.9
Axial Peaking Factor	1.05 to 2.35
Axial Peak Location	0.14 to 0.90

Parameter Uncertainties for SDL Determination

Variable	Uncertainty	Distribution
Core Power	$\pm 2.2\%$ at 2σ	Normal
Core Flow	$\pm 2.0\%$ at 2σ	Uniform
Core Pressure	± 36.0 psi at 2σ	Uniform
Core Inlet Temp.	$\pm 3.7^\circ\text{F}$ at 2σ	Uniform
Core Bypass Flow	$\pm 1.0\%$	Uniform
Measured $F_{\Delta H}^N$	$\pm 4.0\%$ at 2σ	Normal
Hot channel Factor	2.0%	Normal
DNB Correlation Unc.	[]
LYNXT Code Unc.		
RSM to LYNXT Fit		
Bundie Spacing		
Axial Peaking Factor		
Axial Peak Location		

Table 7.1
Plant Parameters and Operating Conditions

Reactor Power	102% of 2893 MWT
Nominal Pressurizer Operating Pressure	2250 psia
System Flow	288,000 gpm
Hot Leg Temperature	620°F
Cold Leg Temperature	552°F
Steam Generator Operating Pressure	850 psia
Fuel Pin Outside Diameter	0.374 inch
Average Linear Power Generation Rate	5.9 kW/ft
Highest Allowable Total Peaking (F_Q)	2.19

Table 7.2
Discharge Coefficient Study Comparison

Break Discharge Coefficient	1.0	0.8	0.6	0.4
Peak Cladding Temperature Data				
Peak Cladding Temperature, °F	1915	1944	1974	1910
PCT Location, feet	6.3	6.9	6.9	8.6
Rupture Node Data				
Location, feet	6.9	6.3	6.3	6.9
Rupture Time, seconds	59	55	54	78
Peak Temperature at Rupture Location, °F	1756	1770	1848	1668
Oxidation Data				
Local Maximum Oxidation, %	3.4	3.5	4.0	2.9
Location of Peak Oxidation, feet	6.9	6.3	6.3	8.6

Table 7.3
Sequence of Events for DECLPDB $C_d=0.6$
(Time in seconds)

Leak Initiation	0.00
Safety Injection System Trip	3.2
Accumulator Injection Begins	12.0
End of Blowdown	19.0
Bottom of Core Recovery	32.5
Accumulator Empty	50.3
PCT Turnaround	96
Core Quench	679

Table 7.4
Results for Variant Axially Peaked LBLOCA Cases

Axial Peak Position, feet	4.6	6.7	10.1
Peak Cladding Temperature Data			
Peak Cladding Temperature, °F	1935	1966	1928
Location of Peak Cladding Temperature, feet	6.1	7.0	8.7
Rupture Node Data			
Peak Temperature, Ruptured Node, °F	1846	1765	1841
Location of Rupture, feet	5.1	6.1	9.6
Rupture Time, seconds	52	56	62
Oxidation Data			
Maximum Local Oxidation, %	3.9	3.5	4.7
Location of Peak Oxidation, feet	5.1	7.9	9.6

Table 7.5
Comparison of Virginia Electric and Power Company and FTI
LOCA Calculation Results

	North Anna NAIF Results		FTI Mark-BW17 Results	
	Unit 1	Unit 2	Unit 1	Unit 2*
Peak Cladding Temperature, °F	1975	2013	1966	2004
Maximum Local Oxidation, %	4.5	5.7	3.5	< 5.7

* The upflow-to-downflow Δ PCT from the NAIF calculations, as described in Section 7.1.1, has been used to determine the cladding temperature value. For the local oxidation it is merely recognized that the value will be less than the corresponding NAIF value.

Figure 1.1
Mark-BW17 Lead Test Assembly Design

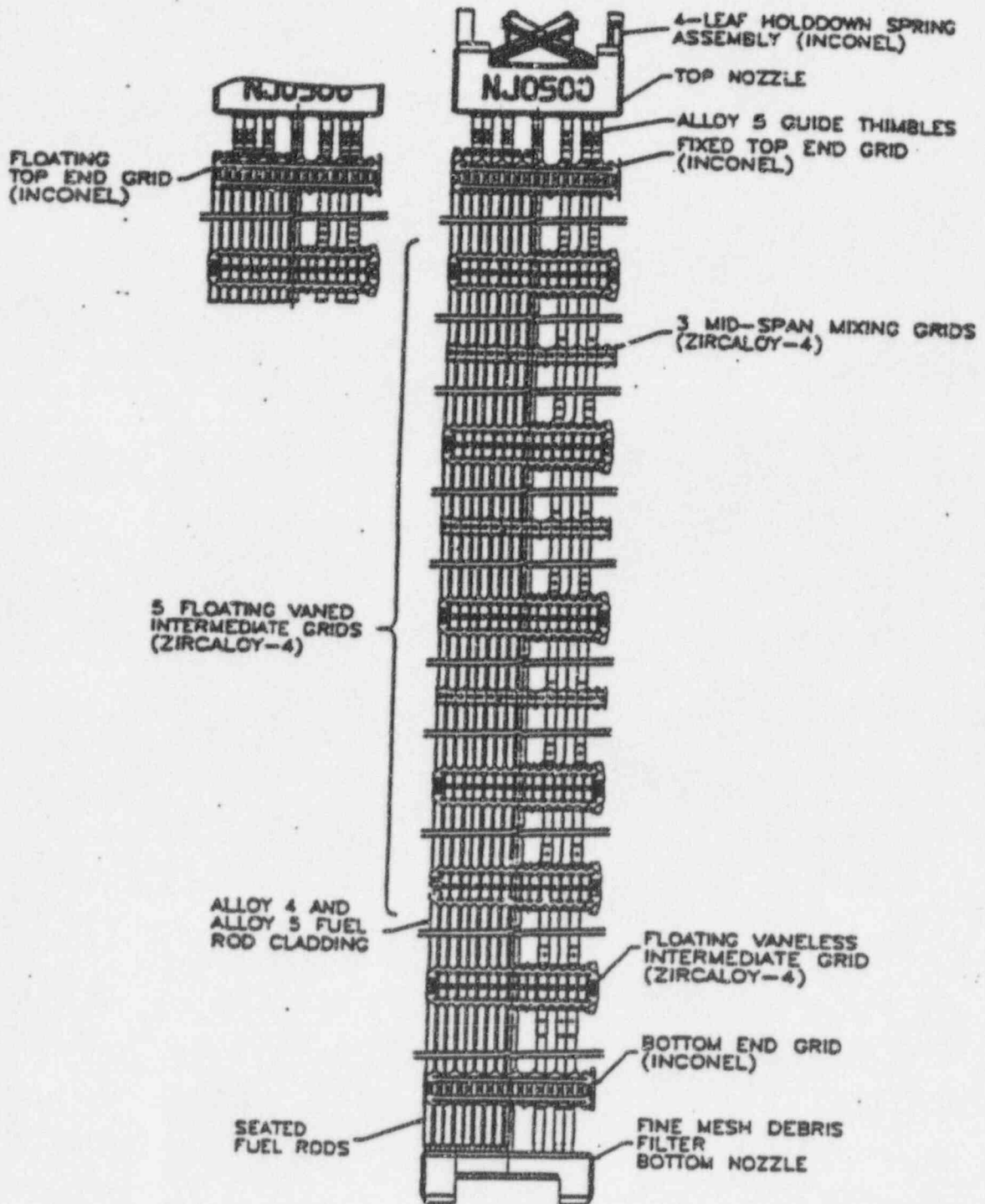
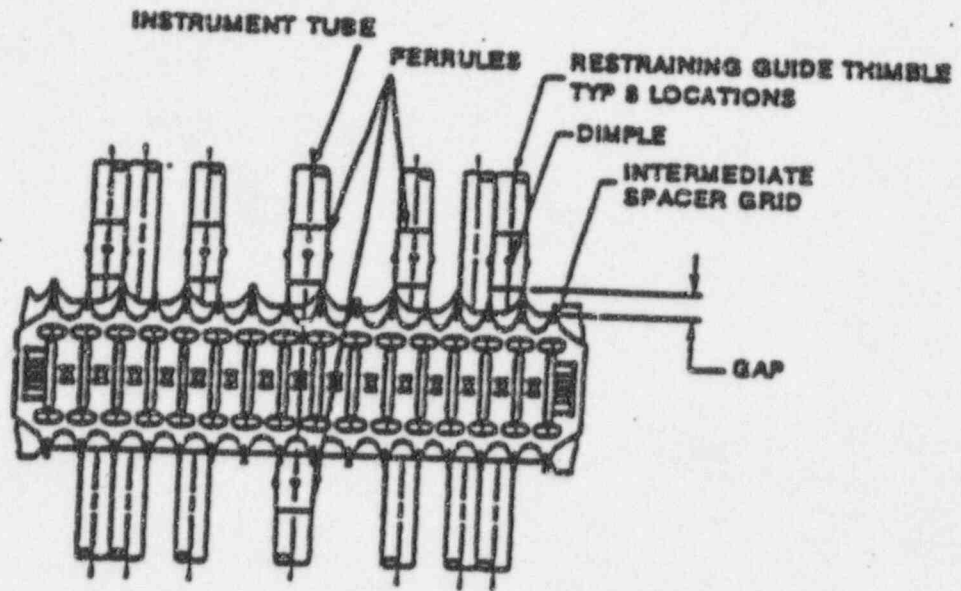
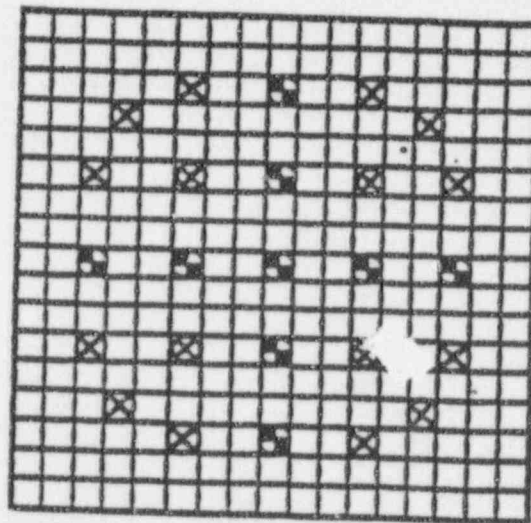

Figure 1.2
Spacer Grid Restraint System
(Intermediate Grid Shown)



RESTRAINING GUIDE THIMBLE LOCATIONS DENOTED BY ⊕



MSMG RESTRAINING LOCATIONS DENOTED BY ⊗

Figure 1.3
Comparison of Mixing Vanes for
Intermediate Spacer Grids and
Mid-Span Mixing Grids



VANE COMPARISON OVERLAY
Mark-BW17 Intermediate Grid Vane Shown Solid
MSMG Vane Shown in Hidden Line

Figure 1.4
Mid-Span Mixing Grid Design

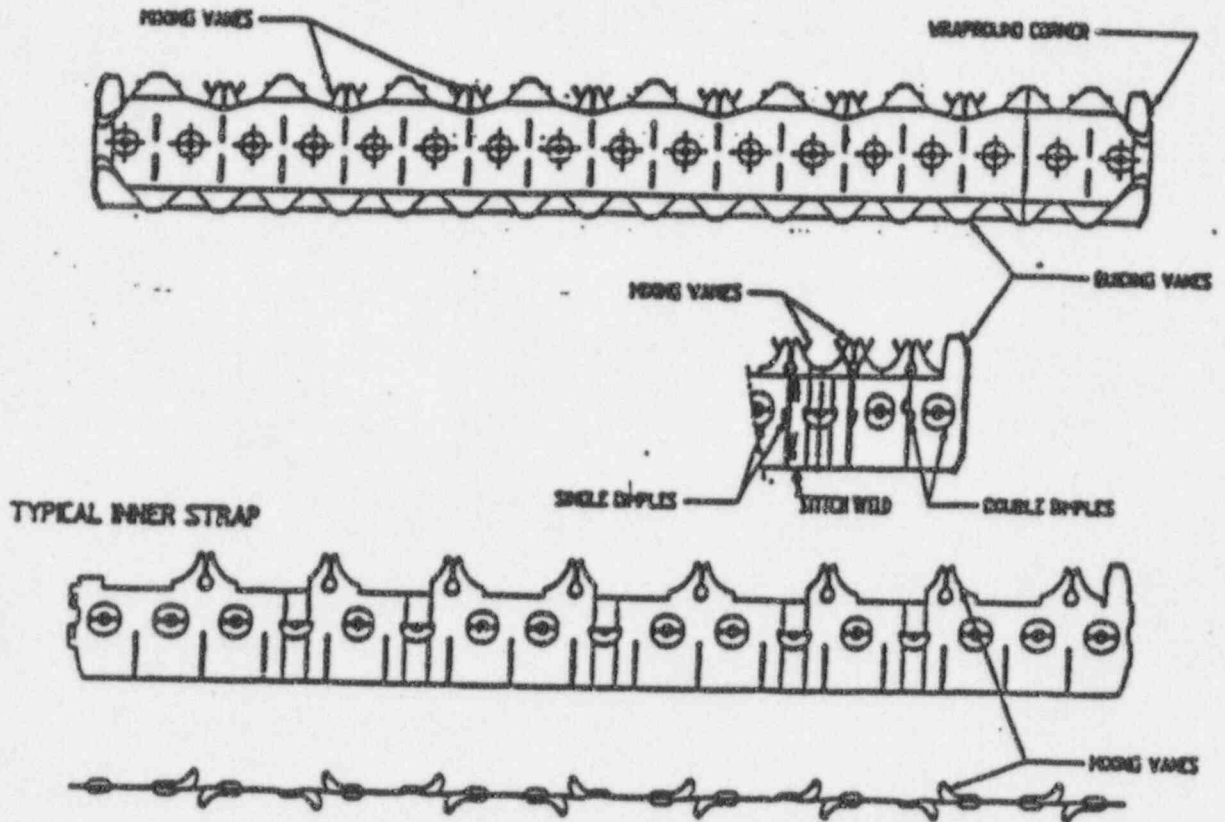

Figure 1.5
Bottom Nozzle Filter Plate Geometry

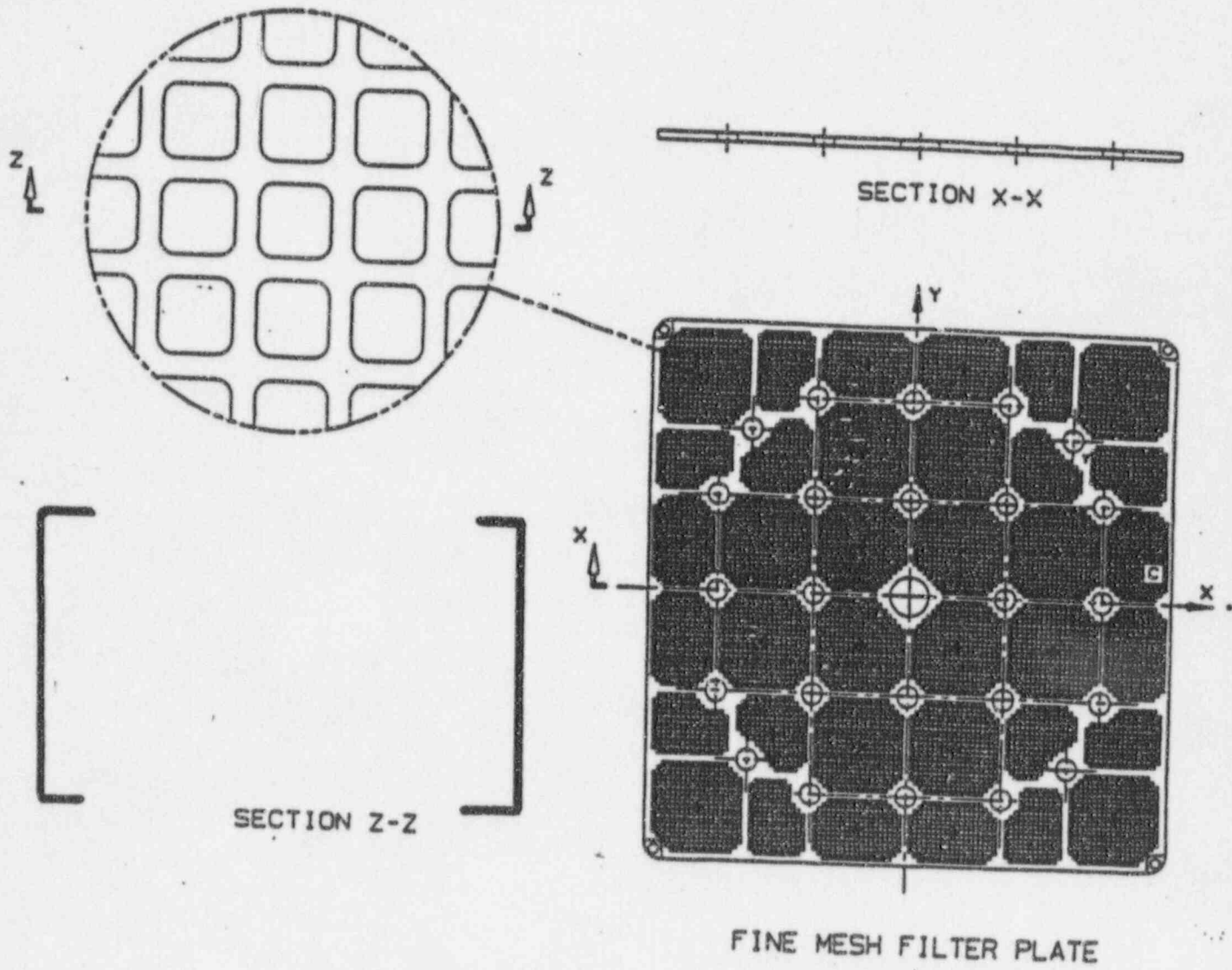

Figure 1.6
Alloy 4 Locations in Lead Test Assemblies
(2 assemblies only)

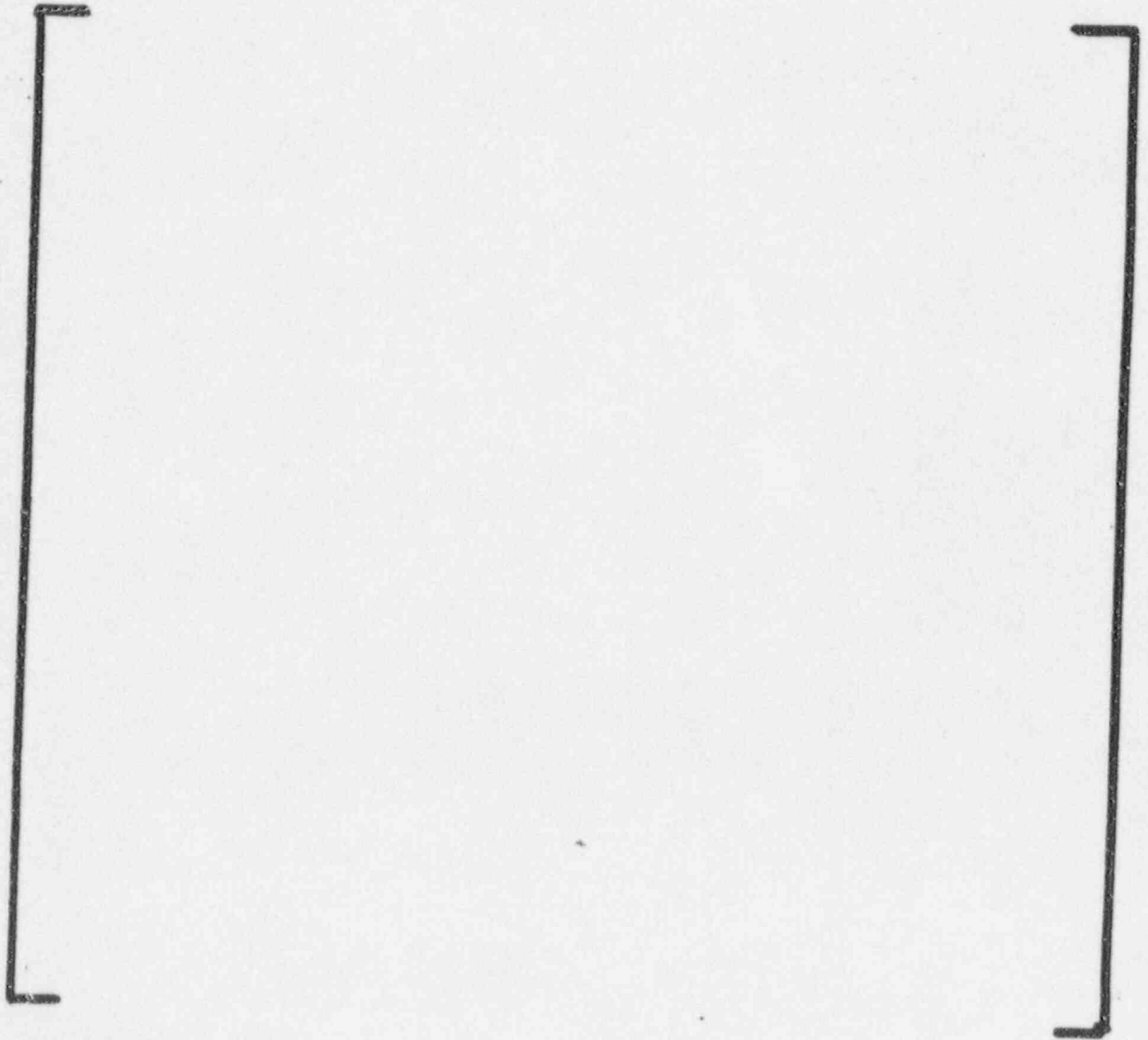

Figure 1.7
Mark BW-17 Fuel Rod Assembly

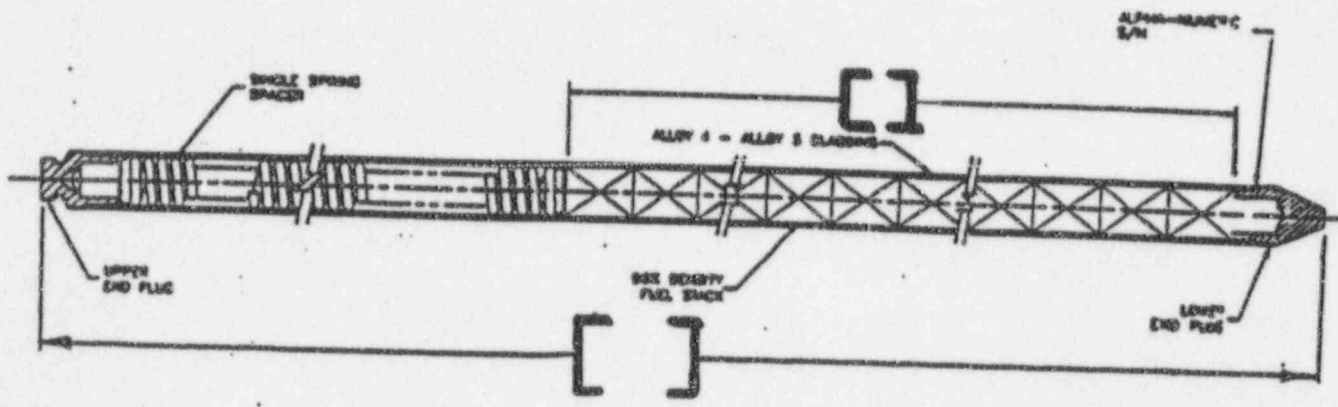

Figure 7.1
 RSG LOCA EM Computer Code Interface Diagram

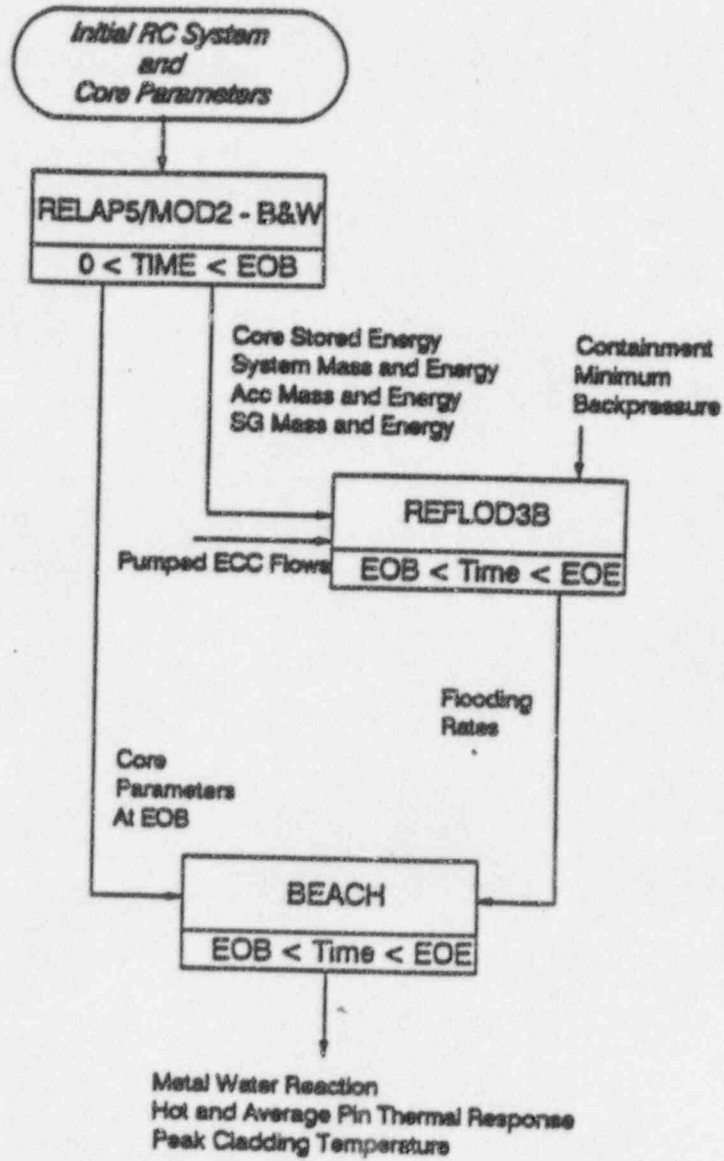

Figure 7.2
RELAP5/MOD2 LBLOCA Loop Noding Arrangement

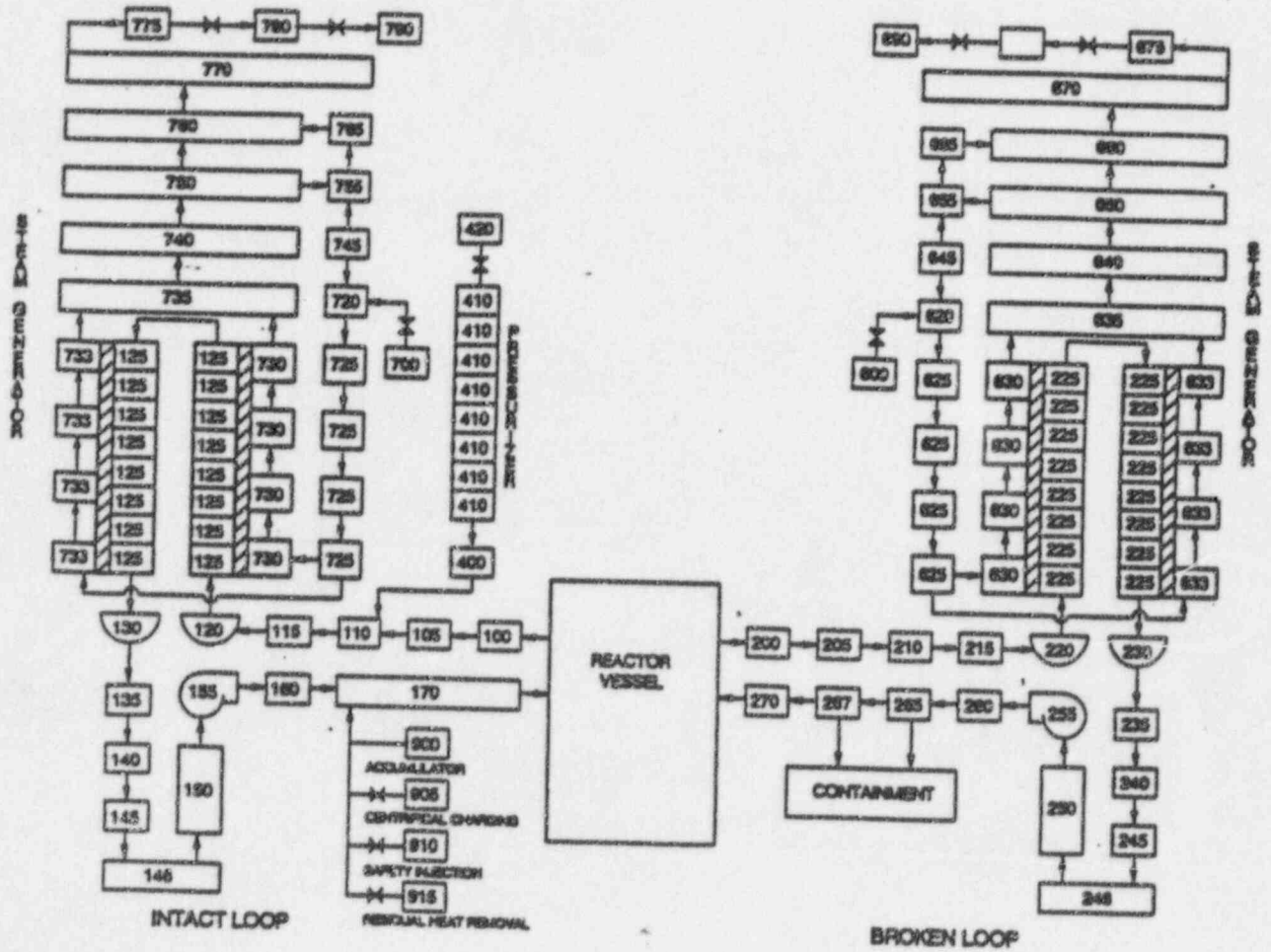

Figure 7.3
 RELAP5/MOD2 LBLOCA Reactor Vessel Noding Arrangement

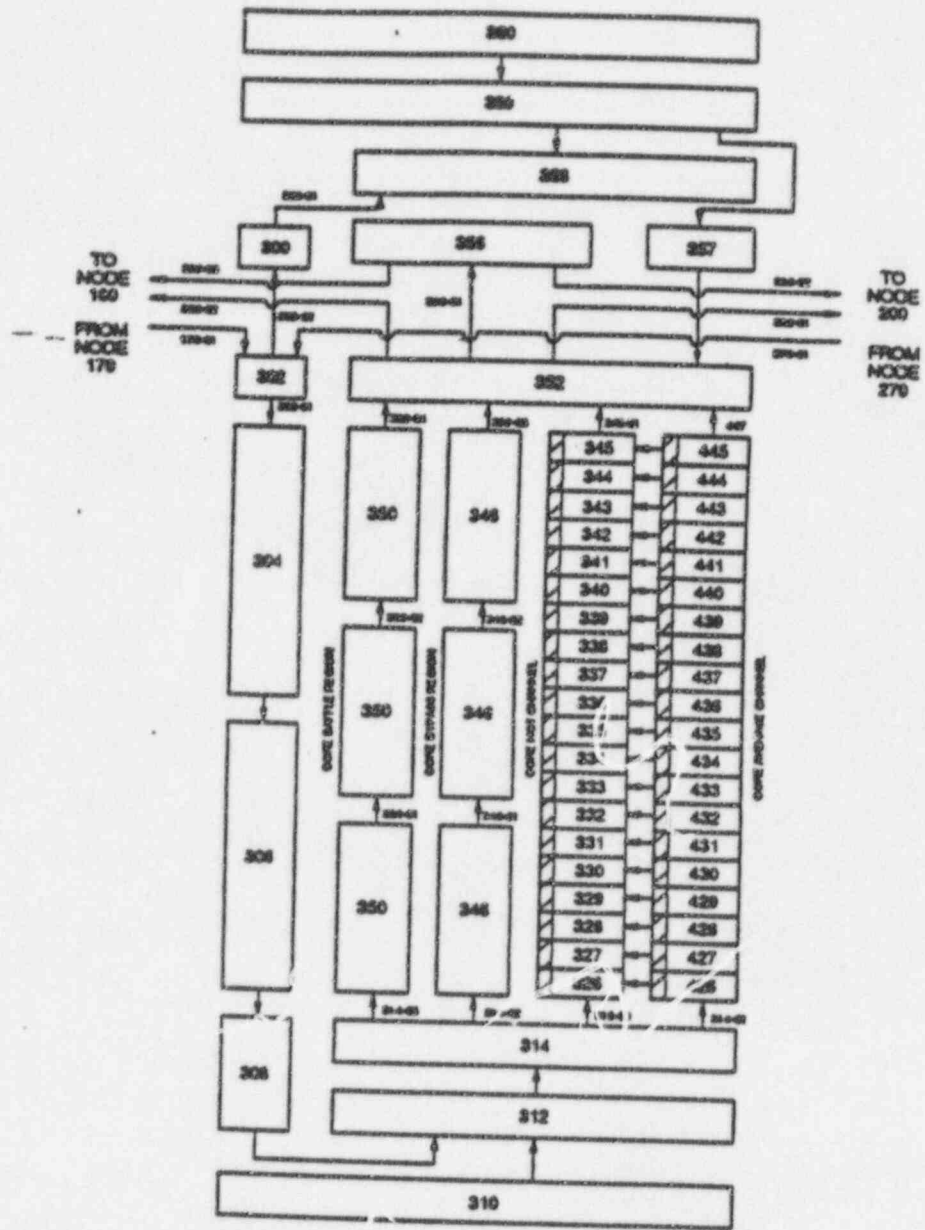
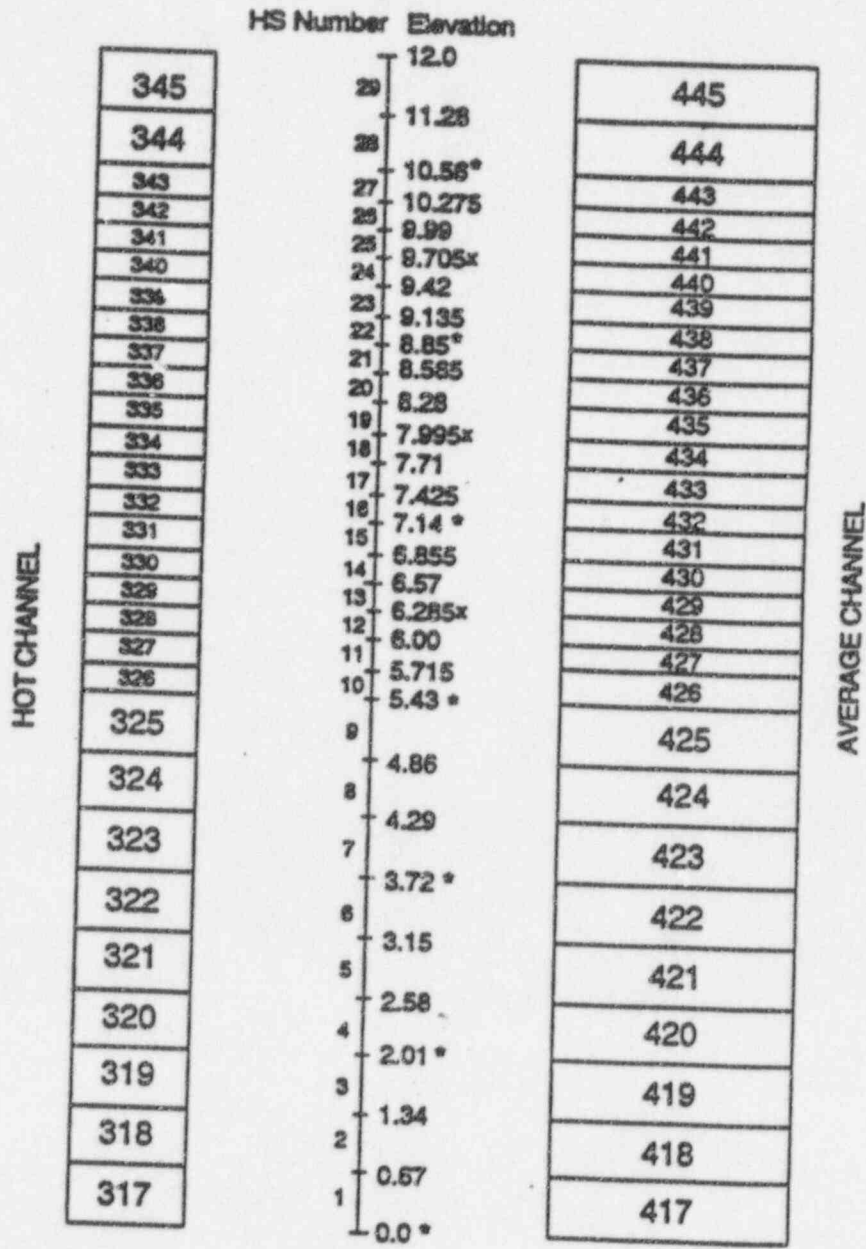

Figure 7.4
 RELAP5/BEACH Core Noding
 with Mid-Span Mixing Grids Modeled



* Grid Location
 X MSMG Location

Figure 7.5
REFLOD3B Noding Diagram

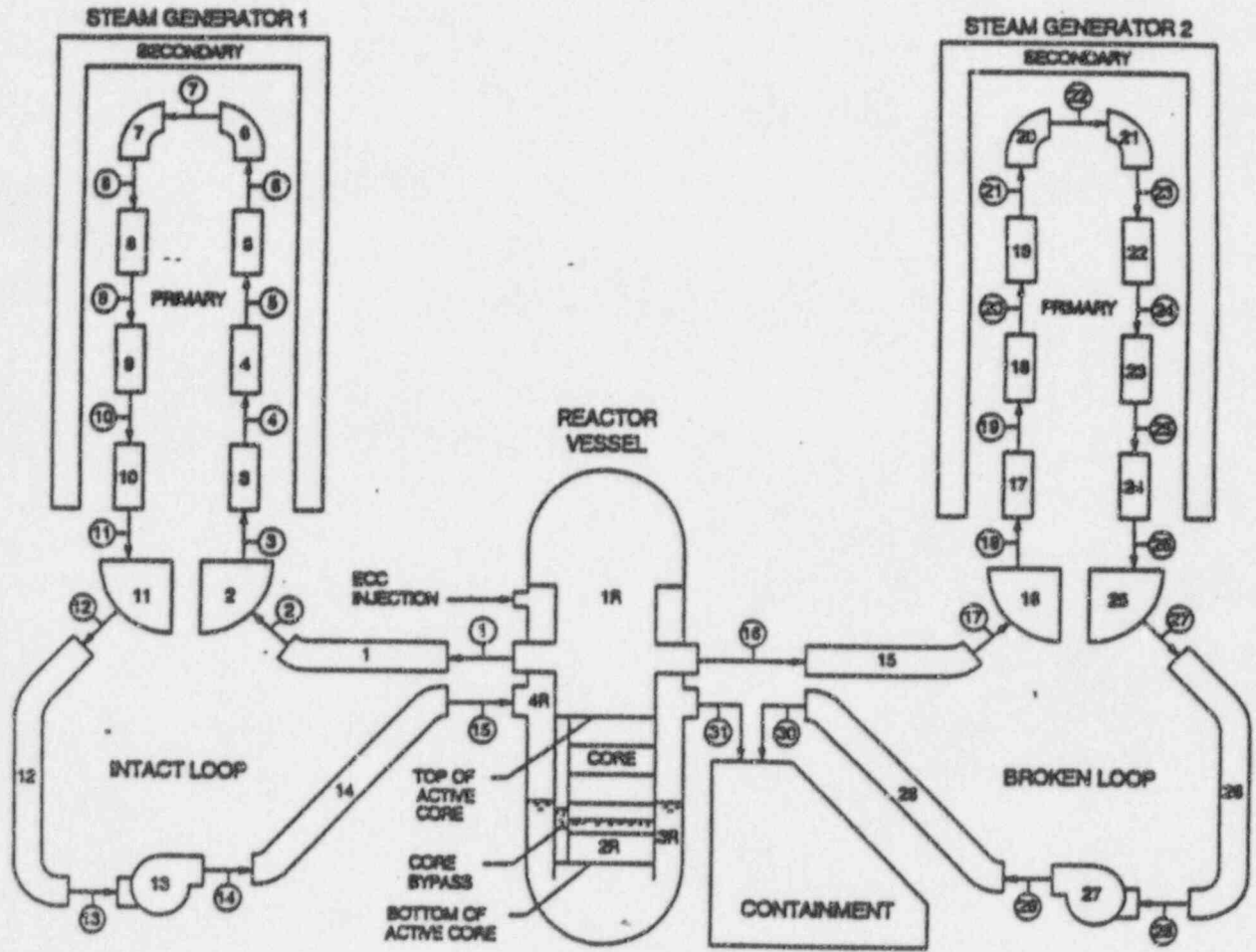

Figure 7.6
Schematic of EDGAR Test Facility



Figure 7.7
Comparison of NUREG-0630 Correlations and Data
to Alloy 5 Testing: Rupture Temperature



— NUREG 0630 model ■ NUREG Data, 9 to 11 C/s ● EDGAR Data - M5

Figure 7.8
Comparison of NUREG-0630 Correlations and Data
to Alloy 5 Testing: Rupture Strain



Figure 7.9
Pressure
(Double Ended Cold Leg Pump Discharge Break $C_d = 0.6$)

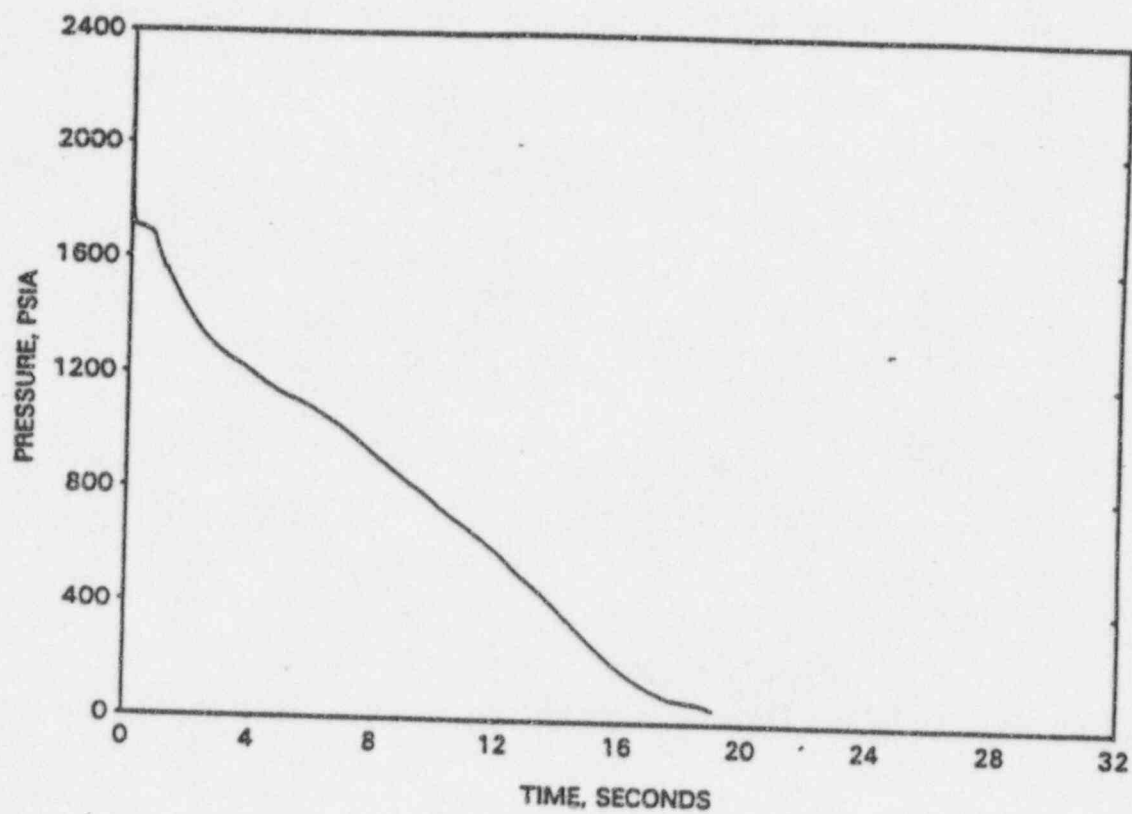

Figure 7.10
Cladding Temperatures
(Double Ended Cold Leg Pump Discharge Break $C_d = 0.6$)

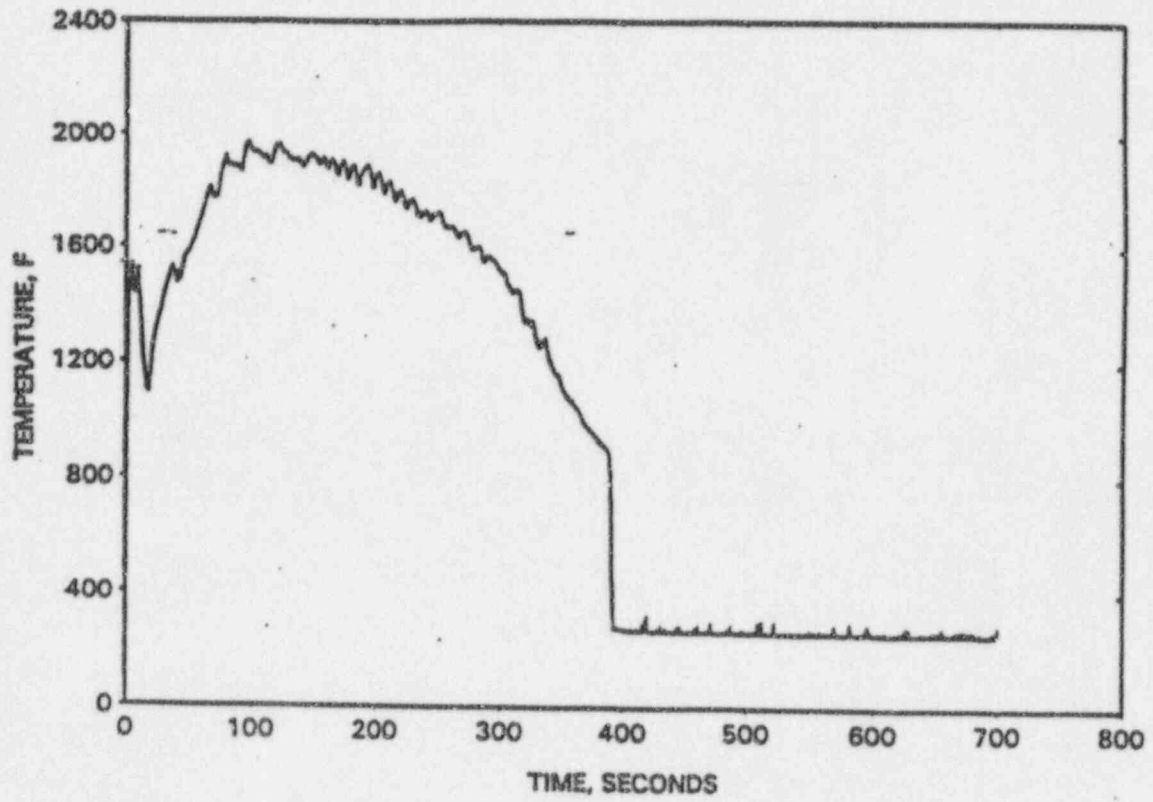

Figure 7.11
Reflood Rate
(Double Ended Cold Leg Pump Discharge Break $C_d = 0.6$)

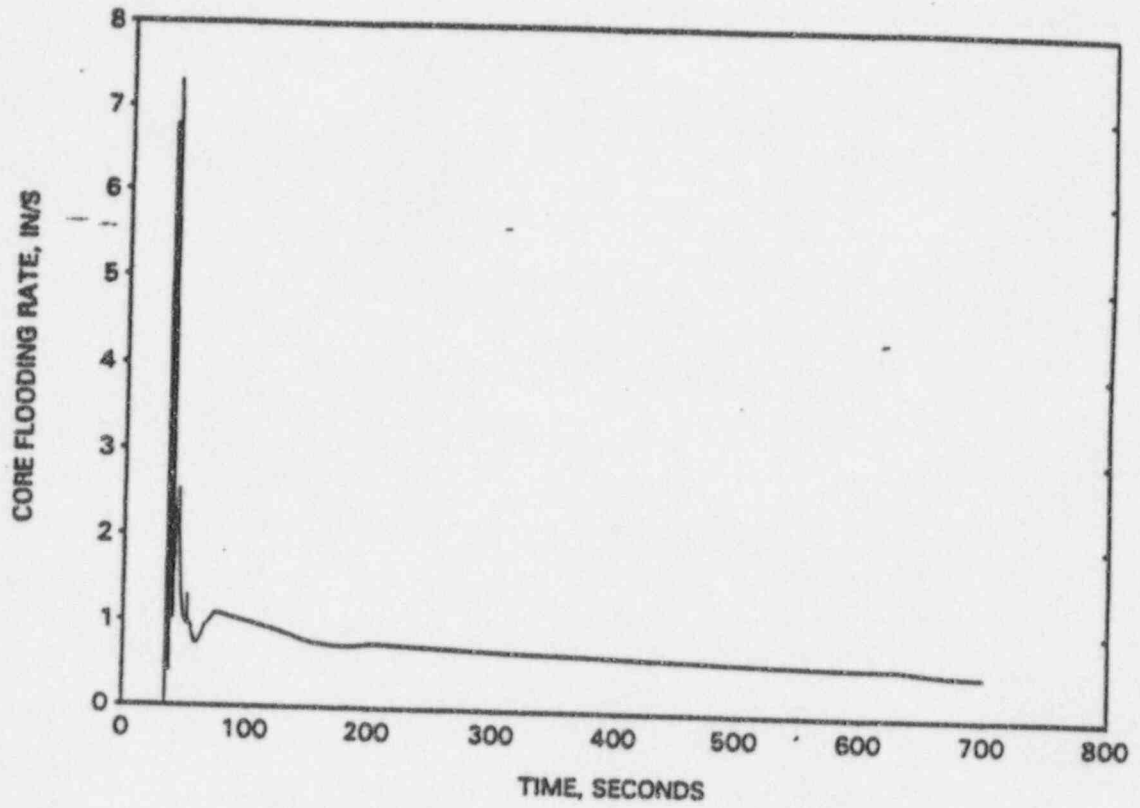

Figure 7.12
Vapor Temperature
(Double Ended Cold Leg Pump Discharge Break $C_d = 0.6$)

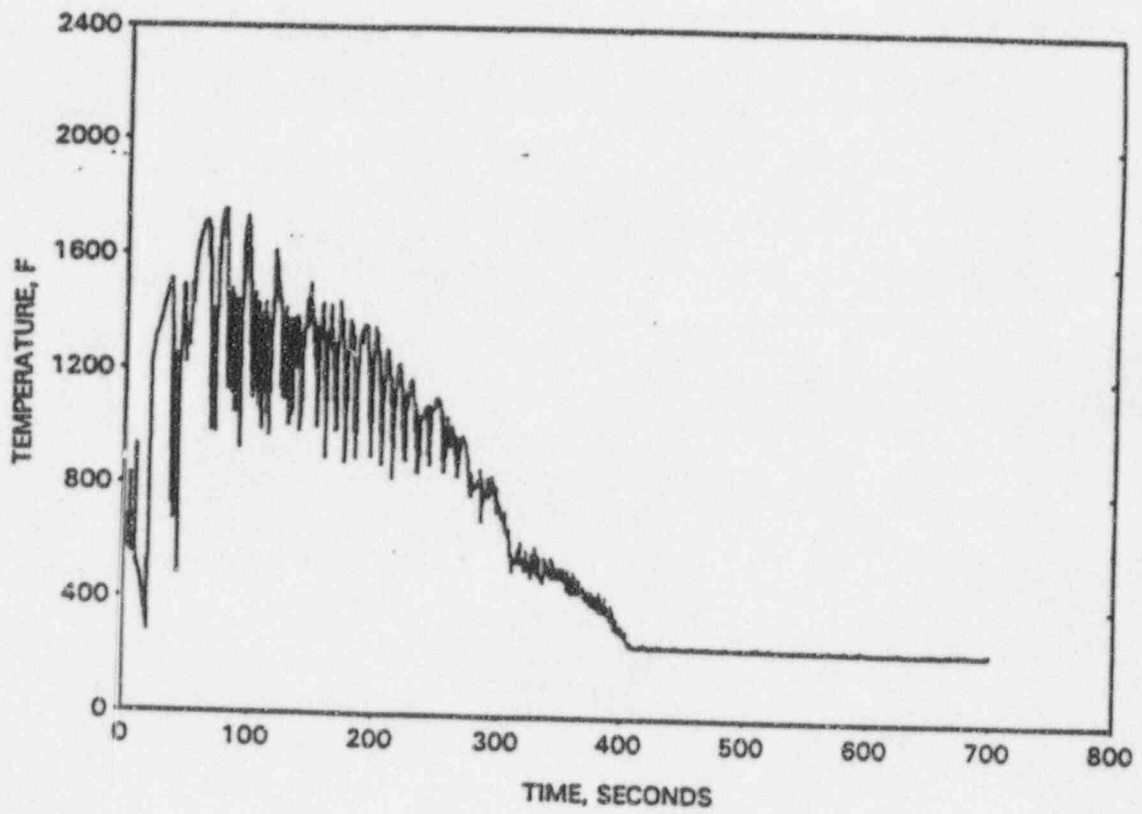

Figure 7.13
Heat Transfer Coefficient
(Double Ended Cold Leg Pump Discharge Break $C_d = 0.6$)

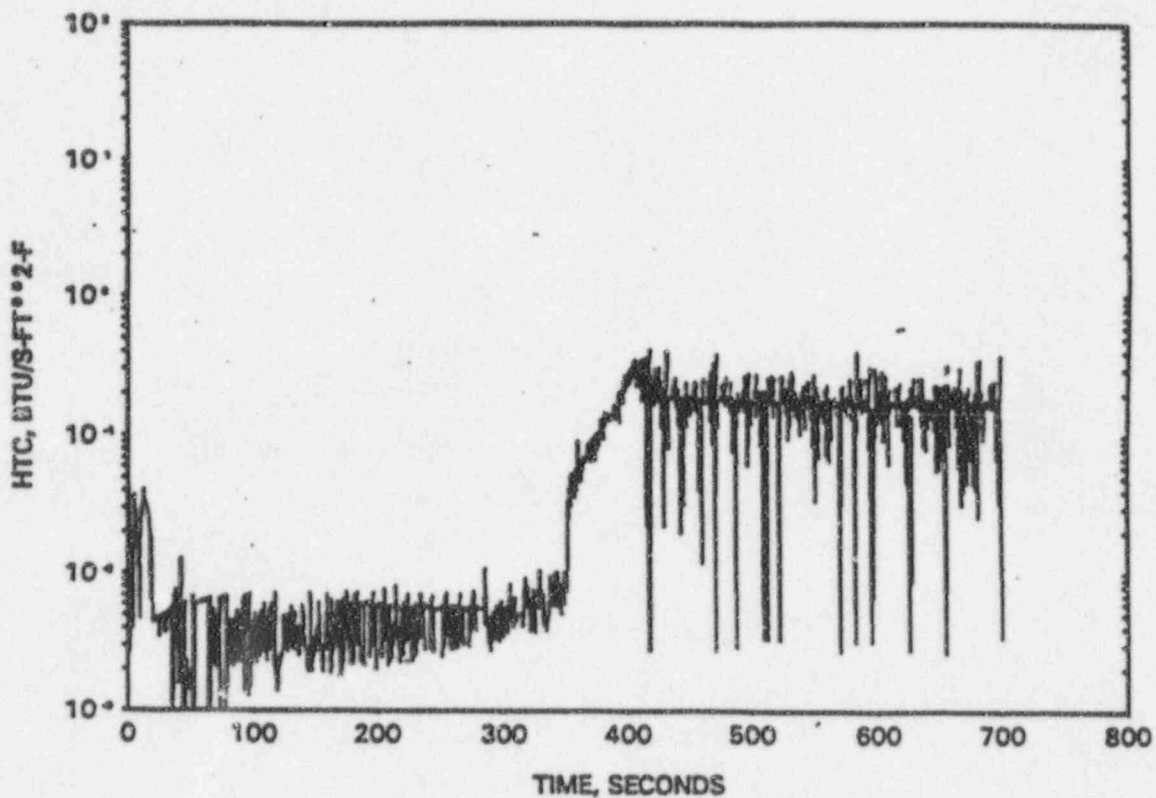

Figure 7.14
Cladding Temperature Comparisons
for $C_d = 1.0, 0.8, 0.6$ and 0.4

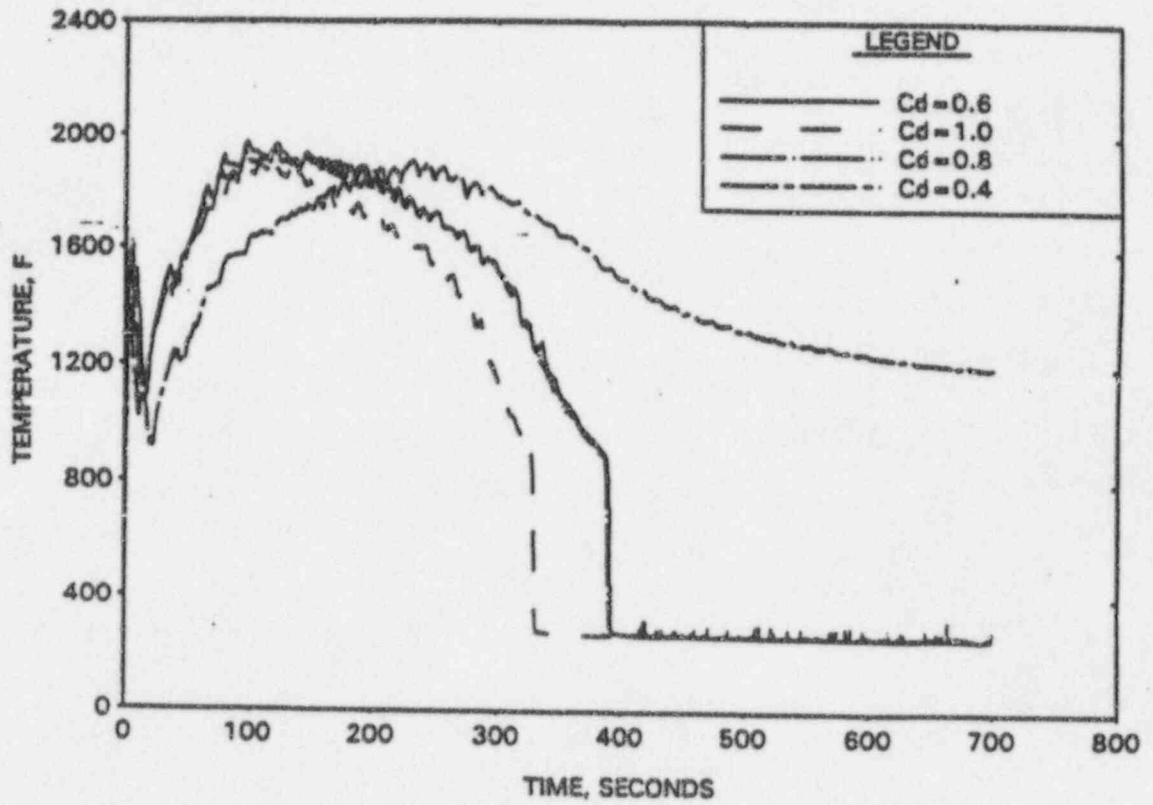

Figure 7.15
Normalized Core Axial Power Limit, K_z

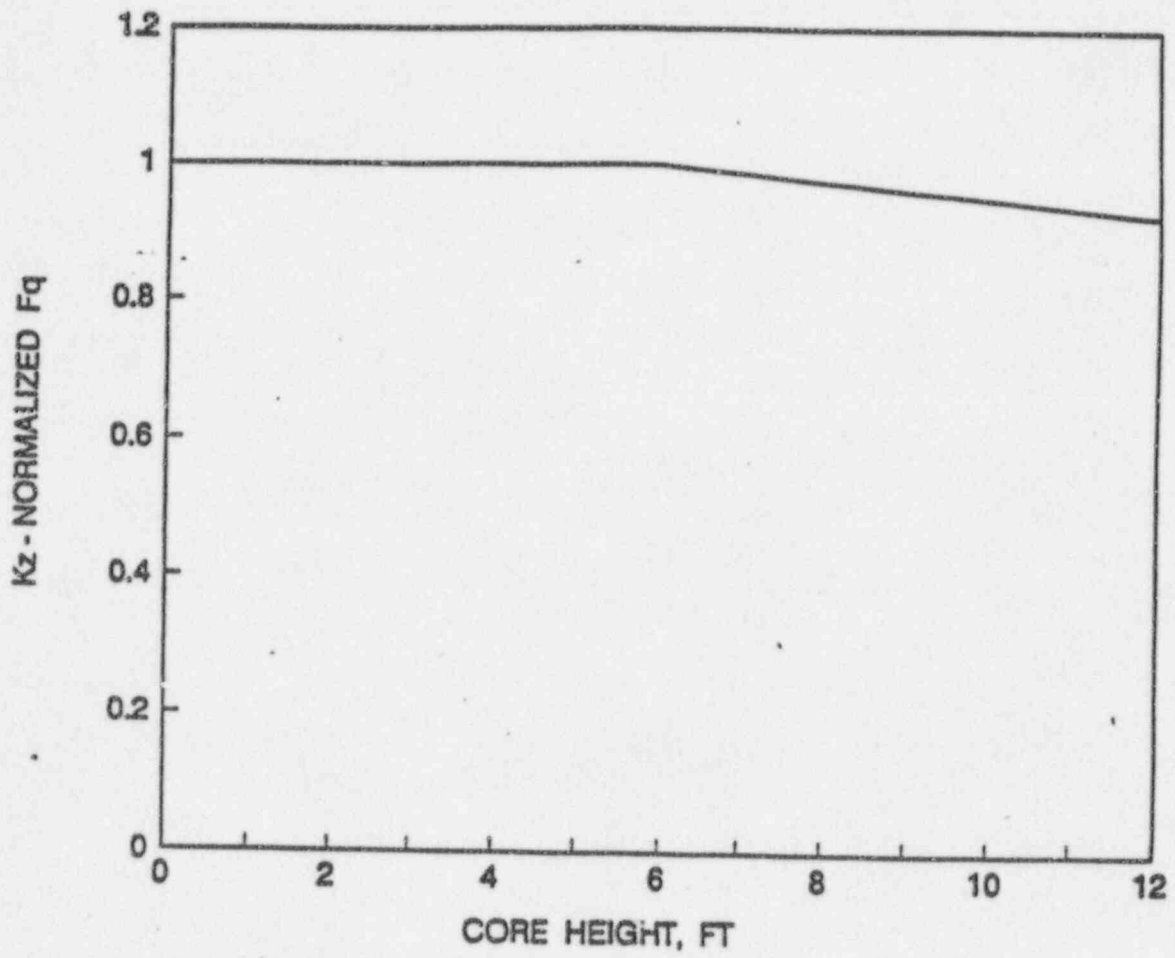

Figure 7.16
Axial Power Peaking Distributions Used in LTA LOCA Calculations

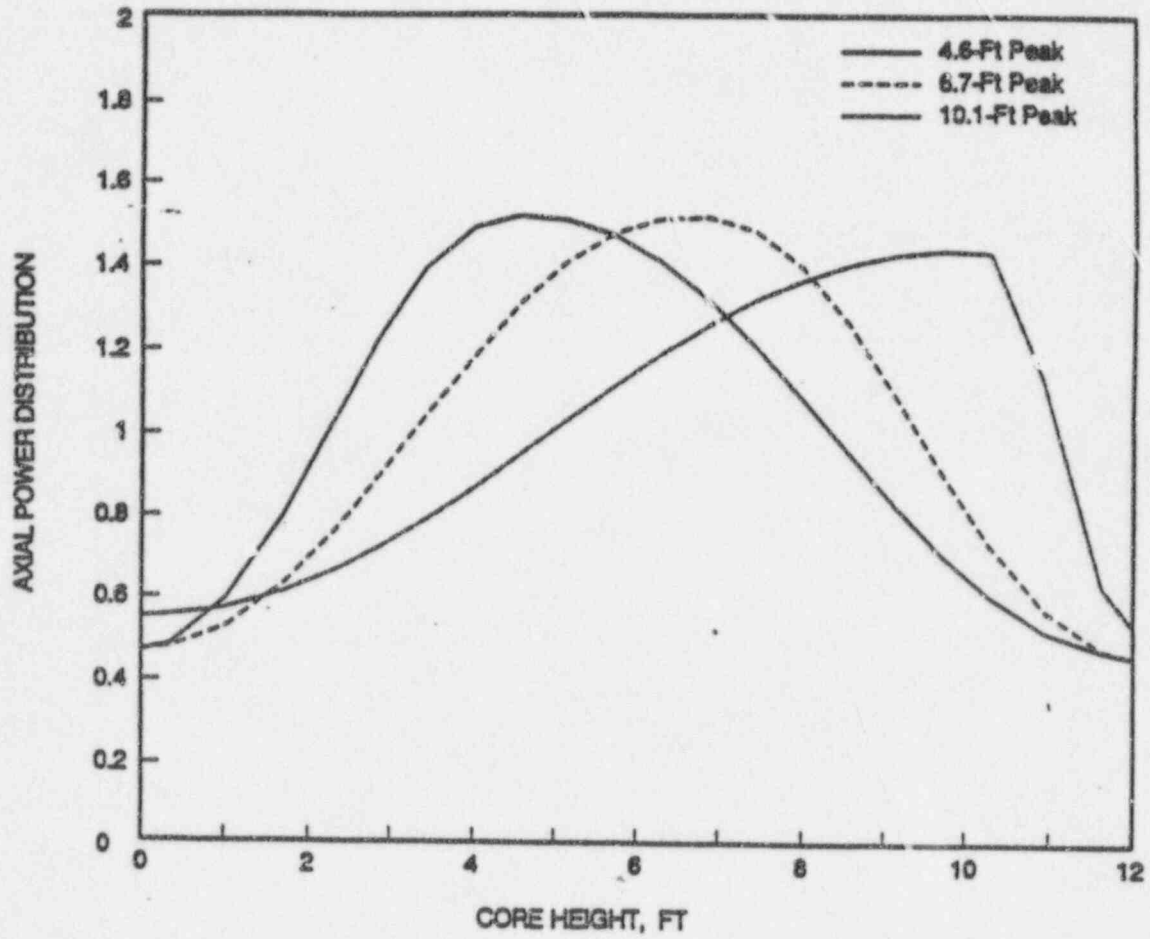

Figure 7.17
Cladding Temperatures for the Worst Case LOCA
with the Core Peak Power at 6.7 Feet

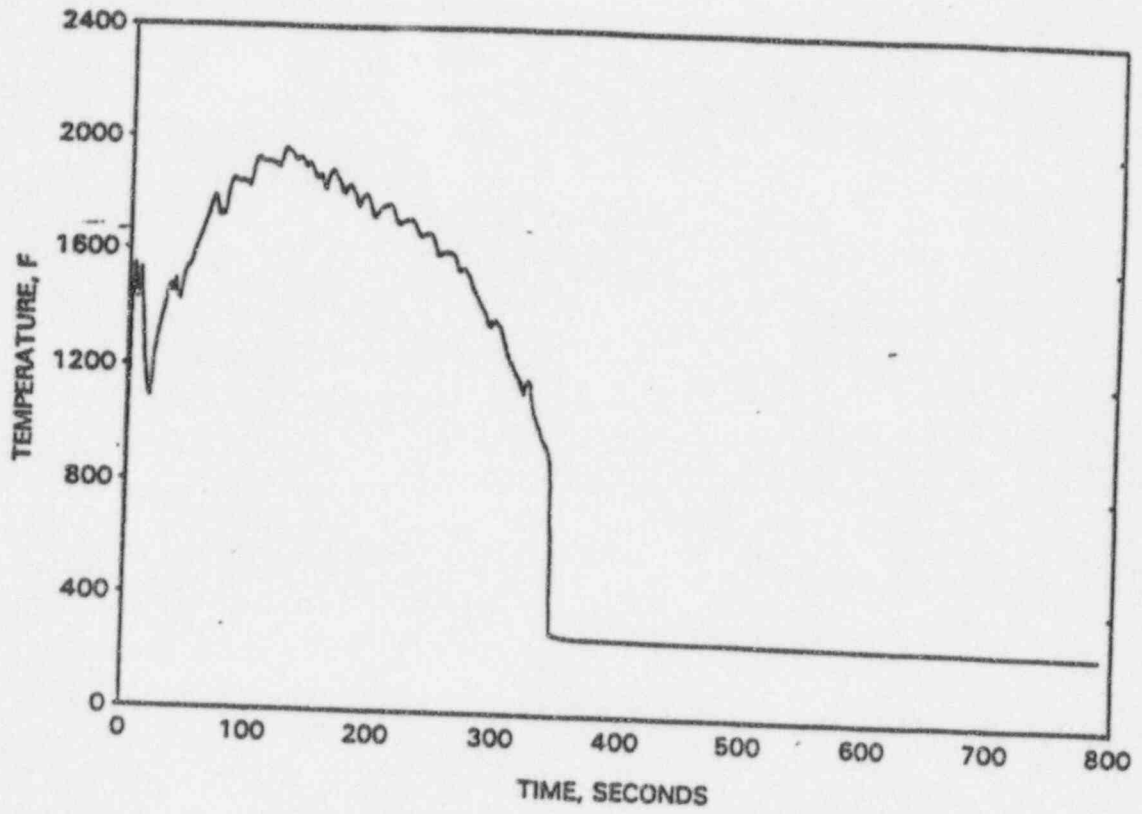

Figure 7.18
Vapor Temperature at the Hot Spot for the Worst Case LOCA
with the Core Peak Power at 6.7 Feet

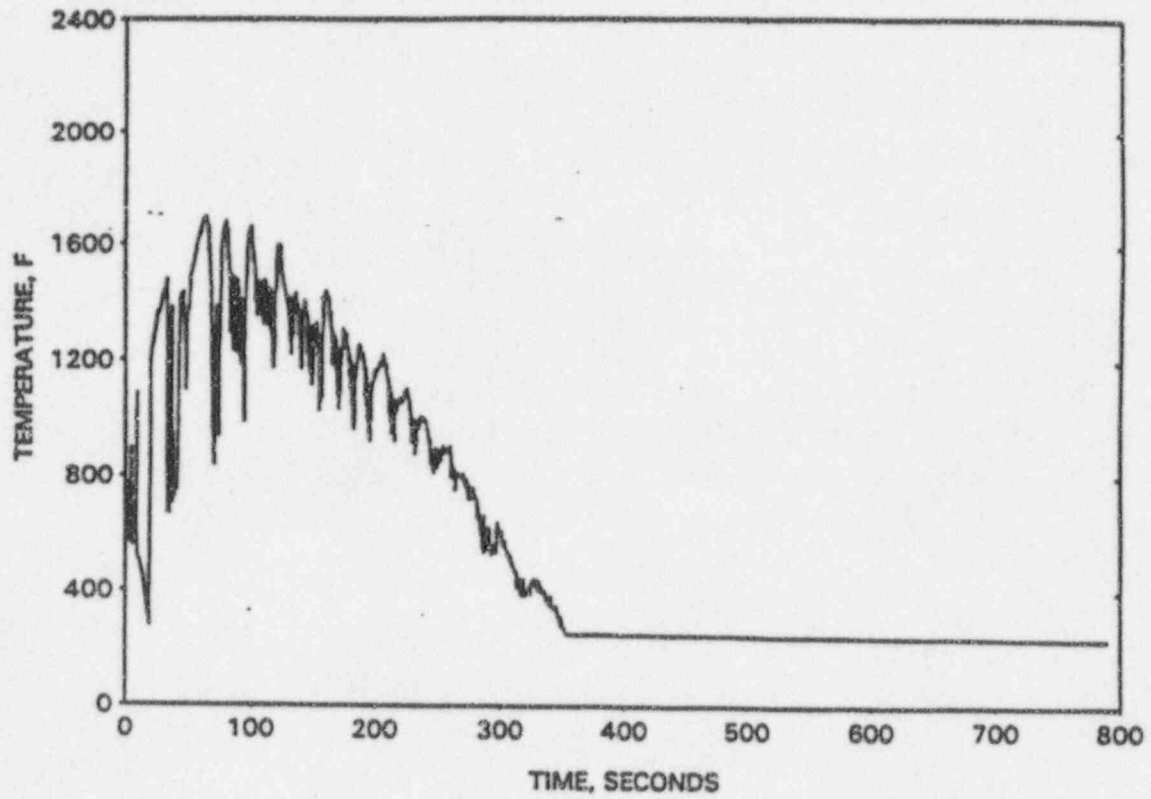

Figure 7.19
Hot Spot Heat Transfer Coefficient for the Worst Case LOCA
with the Core Peak Power at 6.7 Feet

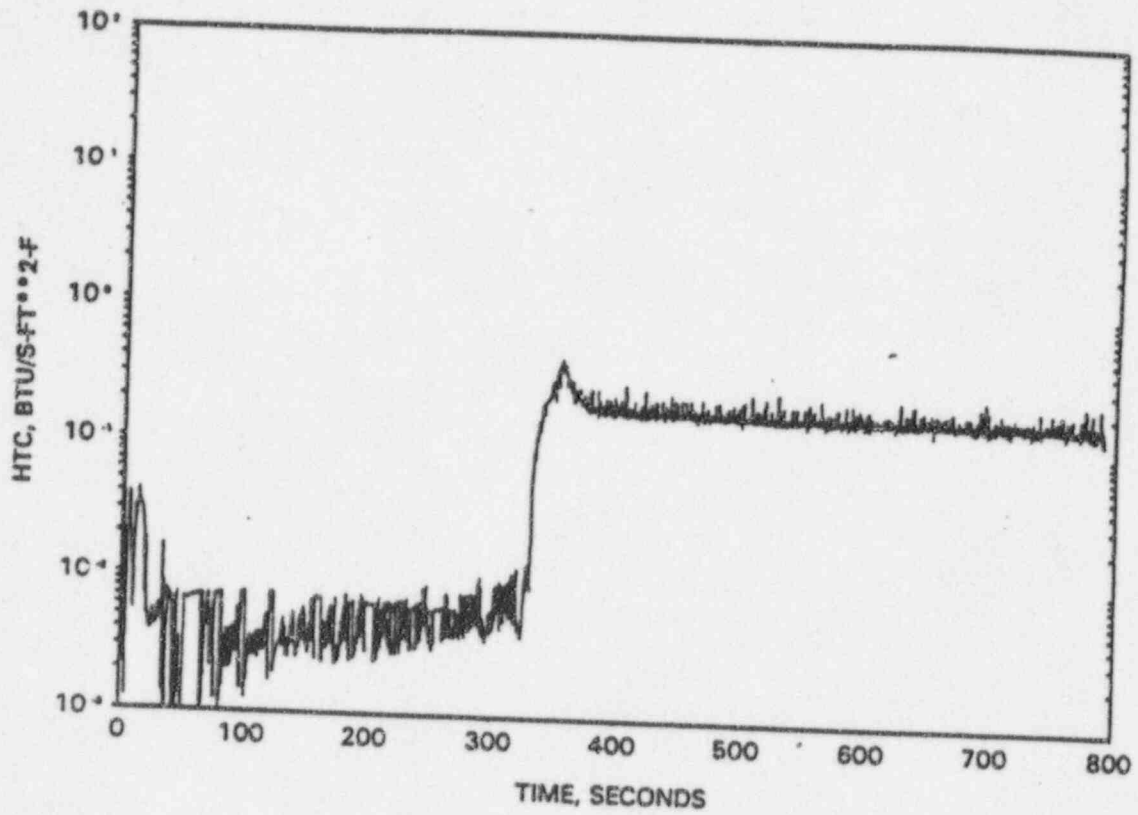
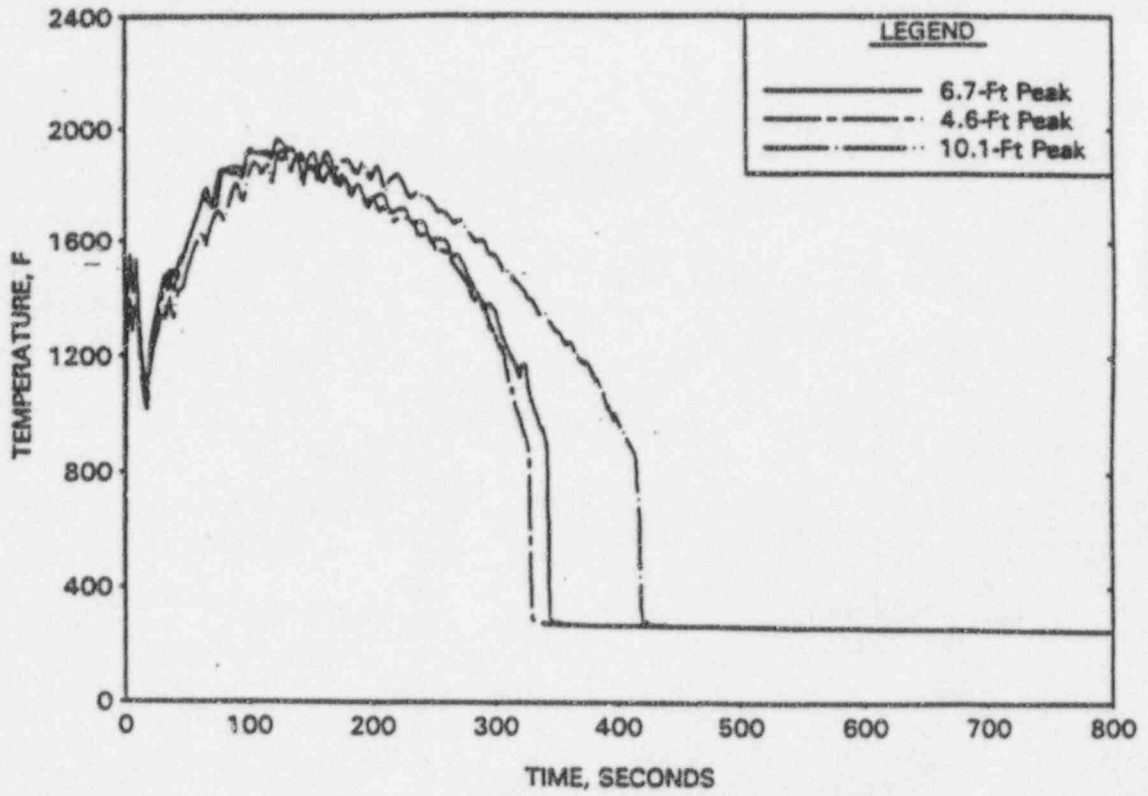

Figure 7.20
Peak Cladding Temperatures for
Axial Peaking at the 4.6, 6.7, and 10.1 Foot Elevations



REFERENCES

1. Letter from W. L. Stewart (Virginia Electric and Power Company) to Leon B. Engle (NRC), "North Anna Power Station Units 1 and 2 - Proposed Technical Specifications Change - North Anna Fuel Assembly Design Change," Serial Number 89-795, January 15, 1990.
2. Letter from W. L. Stewart (Virginia Electric and Power Company) to U. S. Nuclear Regulatory Commission, "North Anna Power Station Units 1 and 2 - Proposed Technical Specifications Changes - Implementation of ZIRLO Cladding," Serial Number 93-614, October 4, 1993.
3. "Reload Nuclear Design Methodology," VEP-FRD-42, Rev. 1-A, September 1986.
4. Bordelon, F. M., et al., "Westinghouse Reload Safety Evaluation Methodology," WCAP-9272-P-A (Proprietary) and WCAP-9273-A (Non-Proprietary), July 1985.
5. "Mark-BW Mechanical Design Report," BAW-10172P, July 1988.
6. ASME Code, Section III, Division I, Subsection NG, Boiler and Pressure Vessel Code, 1980.
7. Technical Specifications - North Anna Power Station, Unit Number 1, Docket 50-338, through Amendment No. 200, April 1, 1996.
8. Technical Specifications - North Anna Power Station, Unit Number 2, Docket 50-339, through Amendment No. 181, April 1, 1996.
9. Standard Review Plan, Section 4.2, NUREG-0800, Revision 2, U. S. Nuclear Regulatory Commission, July 1981.
10. North Anna Power Station Updated Final Safety Analysis Report, Section 5A, "Analysis and Effects of LOCA on Reactor Coolant System Supports," Amendment Number 43, December 1, 1975.
11. "Mark-BW Advanced Claddings Fuel Rod Evaluation," BAW-2133P, March 1991.
12. "TACO3 - Fuel Pin Analysis Computer Code," BAW-10162P-A, October 1989.
13. "Program to Determine In-Reactor Performance of BWFC Fuel Cladding Creep Collapse," BAW-10084P-A, July 1995.
14. "Fuel Rod Gas Pressure Criterion (FRGPC)," BAW-10183P-A, July 1995.
15. "LYNXT: Core Transient Thermal-Hydraulic Program," BAW-10156-A, Revision 1, August 1993.

16. "Statistical Core Design for B&W Designed 177 FA Plant." BAW-10187P-A. March 1994.
17. "Statistical Core Design for Mixing Vane Cores." BAW-10170P-A. December 1988.
18. "CHF Testing and Analysis of the Mark-BW Fuel Assembly Design." BAW-10189P-A. January 1996.
19. "The BWU Critical Heat Flux Correlations," BAW-10199P, December 1994.
20. R. C. Anderson, "Statistical DNBR Evaluation Methodology," VEP-NE-2-A, June 1987.
21. Letter from W. L. Stewart (Virginia Electric and Power Company) to U. S. Nuclear Regulatory Commission, "North Anna Power Station Units 1 and 2, Proposed Technical Specifications Change," Serial Number 87-231, June 17, 1987.
22. "Fuel Rod Bowing in Babcock & Wilcox Fuel Designs - Revision 1," BAW-10147PA-R1, May 1983.
23. "Extended Burnup Evaluation," BAW-10186P, November 1992.
24. J. G. Miller, "VEPCO Nuclear Design Reliability Factors," VEP-FRD-45A, October 1982.
25. K. L. Basehore, et al., "Virginia Power Relaxed Power Distribution Control Methodology and Associated FQ Surveillance Technical Specifications," VEP-NE-1-A, March 1986.
26. "VEPCO Evaluation of the Control Rod Ejection Transient," VEP-NFE-2-A, December 1984.
27. Updated Final Safety Analysis Report - North Anna Power Station, Units 1 and 2, Docket Nos. 50-338 and 50-339.
28. "RSG LOCA-B&W LOCA Evaluation Model for Recirculating Steam Generator Plants," BAW-10168 Revision 3, B&W Nuclear Technologies, October 1993.
29. D. A. Powers and R. O. Meyer, "Cladding Swelling Models for LOCA Analyses," NUREG-0630, April 1980.
30. "RELAP5/MOD2-B&W, An Advanced Program for Light Water Reactor LOCA and Non-LOCA Transient Analysis," BAW-10164 Revision 3, B&W Nuclear Technologies, October, 1992.
31. "BEACH, Best Estimate Analysis Core Heat Transfer," BAW-10166 Revision 4, B&W Nuclear Technologies, October, 1992.

32. H. M. Chung and T. F. Kassner, "Embrittlement Criteria for Zircaloy Fuel Cladding Applicable to Accident Situations in Light-Water Reactors: Summary Report." NUREG/CR-1344, ANL-79-48, Argonne National Laboratory, Argonne IL, January 1980.