

43
DBAB POR

45.A

T-9000

DISTRIBUTION	
<input checked="" type="checkbox"/>	Original, Responsible Section Head Action
<input type="checkbox"/>	File Copy, Master File

DAVIS-BESSE NUCLEAR POWER STATION - UNIT 1
TEMPORARY MODIFICATION REQUEST
ED 6926

COPIES TO BE MODIFIED FOR IMMEDIATE IMPLEMENTATION	
1 MFC	3 CTM files
1 SS	
1 CTM Book	
1 CTM Log	

SECTION 1

PROCEDURE TITLE AND NUMBER	REASON FOR CHANGE
PRESSURIZER OPERATION	SP1103.05

TO CORRECT PROCEDURE AND PREVENT
CONFLICT WITH AB 1203.18

CHANGE
STEP 2.5 MINIMUM WATER LEVEL WHILE REACTOR POWER IS
GREATER THAN 25% IS 160 INCHES.

8507300322 850327
PDR ADOCK 05000346
P PDR

IS PROCEDURE REVISION REQUIRED Yes No If no, this modification is valid until _____

PREPARED BY	<i>A. Lewis</i>	DATE	3/15/85
APPROVED BY	<i>RA Rutz</i>	DATE	3/15/85
APPROVED BY	<i>L. W. Hieblich</i>	DATE	3/18/85
SUBMITTED BY (Section Head)	<i>WTO Connor / 999</i>	DATE	3/20/85
RECOMMENDED BY (SRB Chairman)	<i>[Signature]</i>	DATE	MAR 27 1985
QA APPROVED BY (Manager of Quality Assurance)		DATE	
APPROVED BY (Station Superintendent)	<i>[Signature]</i>	DATE	MAR 27 1985

Op

N/A

Davis-Besse Nuclear Power Station

Unit No. 1

System Procedure SP 1103.05

Pressurizer Operation

NUCLEAR SAFETY RELATED

Record of Approval and Changes

Prepared by	<u>Bill Nissen & Bob Jadgechew</u>	<u>7/9/75</u>
		Date
Submitted by	<u>Larry Statler/JRL</u>	<u>6/24/76</u>
	Section Head	Date
Recommended by	<u>Jack Evans</u>	<u>6/26/76</u>
	SRB Chairman	Date
QA Approved	<u>NA LES/JLR</u>	
	Manager of Quality Assurance	Date
Approved by	<u>Jack Evans</u>	<u>6/30/76</u>
	Station Superintendent	Date

Revision No.	SRB Recommendation	Date	QA Approved	Date	Sta. Supt. Approved	Date
11	<i>sm</i>	12/4/81	NA		<i>Tom</i>	1/13/82
12	<i>sm</i>	6/22/82	NA		<i>Tom</i>	7/14/82
13	<i>sm</i>	8/3/82	NA		<i>Tom</i>	8/11/82
14	<i>sm</i>	3/22/83	NA		<i>Tom</i>	5/11/83
15	<i>sm</i>	8/30/83	NA		<i>Tom</i>	7/22/83
16	<i>sm</i>	7/5/84	NA		<i>Tom</i>	7/17/84
					Plant Manager Approval/Date	
		FEB 20 1985	NA		<i>sm</i>	3/6/85
17	<i>sm</i>					

1. PURPOSE

- 1.1 To provide procedures for operating the pressurizer in the following modes:

<u>Mode</u>	<u>Section</u>
Pressurization (Startup)	4
Normal Power Operation	5
Depressurization (Shutdown/Cooldown)	6

Description

10| The pressurizer is a vertical-cylindrical vessel that is connected
 10| to the reactor outlet piping by the 10" surge piping. The
 electrically heated pressurizer establishes and maintains RC
 pressure within prescribed limits and provides a steam space
 surge chamber and a water reserve to accommodate changes in
 reactor coolant volume during operation. The water volume is
 based on the capability of the system to experience a reactor
 trip and not lose level indication while maintaining the pressure
 high enough to preclude activation of the HP injection system
 (1650 psig). The steam volume is based on the capability of the
 system to experience a turbine trip and not cover the level
 sensors in the upper shell (327").

Spray nozzle in the upper section and replaceable electric
 heater bundles in the lower half maintain the steam and water at
 the saturation temperature corresponding to the desired RCS
 pressure. During outsurges, as the pressure in the reactor
 decreases, some of the water in the pressurizer flashes to steam
 to maintain pressure. Electric heaters are actuated to restore
 the normal operating pressure. During insurges, as pressure in
 the reactor system increases, some of the steam condenses and a
 water spray from a reactor inlet line also condenses steam and
 thus reduces pressure. Spray flow and heaters are controlled by
 the pressurizer's pressure controller.

Pressurizer Heater Bank Controls

There are three bundles of electric heaters located in the lower
 section of the pressurizer. These three bundles are divided
 into six (6) heater banks. Pressurizer heater banks 1, 2, 3,
 and 4 are non-essential heater banks, i.e, the power for these
 banks comes from nonessential sources. Pressurizer Essential
 Heater Banks 1 and 2 are powered from essential sources and are
 required to be operable in order that the unit can be shutdown
 from the Auxiliary Shutdown Panel (ASP) (C3630) and to permit
 RCS pressure control during natural circulation upon a station
 blackout. The following is a summary of the controls for the
 six heater banks. See Enclosure 2 for a summary of the power
 supplies to each heater bank.

Heater Bank 1: Heater Bank 1 has a SCR controller. The heat input to the pressurizer water of this bank can be varied from 0 to 126 KW. Bank 1's controller (PIC-RC2) is a Bailey Hand/Auto Station, located on the Reactor Coolant Makeup and Pressurizer Control Console (C5705) in the control room. When the H/A Station is in AUTO, the heater bank responds to a pressure error signal of -100 psi to 0 psi from 2155 psig RCS pressure. In hand the heat input to the pressurizer water is varied by the operator. The indicator on the H/A Station is scaled 0-100. With MEAS. VAR. selected, the H/A Station indicates the RCS pressure error signal (± 100 psi from 2155 psig), with 0 indicating 2055 psig, 50 indicating 2155 psig. With POS selected the H/A Station indicates the demand signal being sent to the SCR (0 to 100%).

Heater Banks
2, 3 and 4:

When energized, these heater banks will supply 280 KW, 280 KW and 434 KW respectively to the pressurizer water. These heater banks are controlled by an ON-OFF control, i.e., when de-energized heat output is 0KW, when energized heat output is at the bank's maximum KW output. These heater banks are controlled from their respective control switches located on the Reactor Coolant Makeup and Pressurizer Control Console (C5705) in the control room.

Heater Bank Number	Control Switch Name	Control Switch Number
Bank 2	RC PRZR BANK 2 HTR	HIS-RC2-2
Bank 3	RC PRZR BANK 3 HTR	HIS-RC2-3
Bank 4	RC PRZR BANK 4 HTR	HIS-RC2-4

When the respective control switch is placed in "AUTO", the controlled heaters will respond at the pressure and level setpoints shown on Enclosure 7. Manual control of these heater banks is provided by placing the control switch in either the "ON" or "OFF" position. When these heater banks are being operated in manual, they will not respond to either the pressure control signals or the low level interlock.

Essential
Heater Banks
1 and 2:

These heater banks are controlled from essential control circuitry and are used in shutting down the unit from the Auxiliary Shutdown Panel (ASP).

These heater banks each supply 126 KW to the pressurizer water when energized. These heater banks are controlled by an ON-OFF control, i.e., when de-energized heat output is 0 KW, when energized heat output is 126 KW each. These heater banks may be controlled from two locations, the Reactor Coolant Makeup and Pressurizer Control Console (C5705) in the control room and the Auxiliary Shutdown Panel (ASP).

ASP Control
Mode:

In order to obtain control of the Essential Heater Banks from the ASP, the operator must place the ASP "Local-Remote" switch (HIS-RC2-7 for Essential Bank 1, HIS-RC2-8 for Essential Bank 2) in the "Local" position. The following indications will then exist:

1. Annunciator/computer point Q985, "UNIT AUX SD PNL IN OPERATION" will alarm.
2. The amber light above the respective "Local-Remote" switch will be lit and
3. The Amber "SD PNL" indicating light (LI-RC2-5 for Essential Heater Bank 1, IL-RC2-9 for Essential Heater Bank 2) on C5705 will light. The operator will then have manual control of the Essential Heater Bank from the respective control switch at the ASP (HIS-RC2-5 for Essential Heater Bank 1, HIS-RC2-9 for Essential Heater Bank 2). All automatic control as well as low level interlock and control room control for the Essential Heater Banks is defeated when in the ASP control mode.

Control Room
Mode:

In order to obtain control of the Essential Heater Banks from the control room, the operator must place the respective ASP "Local-Remote" switch in the "REMOTE" position. The following indications will then exist:

1. Annunciator/computer point Q985, "UNIT AUX SD PNL IN OPERATION" should clear.
2. The red light above the respective "Local-Remote" switch will be lit.
3. The Amber "SD PNL" indicating light (IL-RC2-5

for Essential Heater Bank 1, IL-RC2-9 for Essential Heater Bank 2) on C5705 will go out.

The operator now has manual control of the Essential Heater Bank from the respective control switch at C5705 (HIS-RC2A for Essential Heater Bank 1, HIS-RC2B for Essential Heater Bank 2). The Essential Heater Banks can now no longer be controlled from the control switches at the ASP.

If the operator places the control room control switch for an Essential Heater Bank (HIS-RC2A for Essential Heater Bank 1, HIS-RC2B for Essential Heater Bank 2) in "AUTO", that Essential Heater Bank will be controlled by the nonessential control signal for the corresponding nonessential heater bank. (Essential Heater Bank 1 will be controlled by the control signal for Heater Bank 2; Essential Heater Bank 2 will be controlled by the control signal for Heater Bank 4.)

With the Essential Heater Banks in Manual (either ON or OFF) all pressure control signals and the Low-Low pressurizer level interlocks are defeated.

If the Essential Heater Banks control room switch (HIS RC2A/HIS RC2B) is in "AUTO" and power is lost to the essential heaters, they will not automatically operate when power is restored. The operator must place the HIS RC2A/HIS RC2B to "ON" and then to "AUTO" for the heaters to operate automatically.

PRESSURIZER HEATER/DH11 AND DH12 INTERLOCK

The pressurizer heater interlock will prevent the pressurizer heaters from being energized when:

- (1) DH11 or DH12 is opened

AND

- (2) RCS pressure is above 301 psig, the setpoint of SFAS CH 1 & CH 4 301 psig bistable BA113 and BA413

The pressurizer heater interlock signals are derived from (1) SFAS Channel 1 301 psig bistable BA113 and SFAS Channel 4 301 psig bistable BA413 - the SFAS bistables receive their RCS pressure signal from the wide range SFAS pressure transmitters; (2) limit switch contacts for DH11 and DH12 to indicate if

either DH11 or DH12 is not fully closed - The logic utilizes both the motor limit switch and stem mounted limit switch for redundant position indication.

The SFAS Channel 4 301 psig bistable EA413 also provides the RCS pressure auto closing signal to DH11. DH11 will receive a close signal when RCS pressure is greater than 331 psig at the centerline of DH11 and DH12 (301 psig as indicated on PIRC2A6).

The heater interlock will de-energize the respective heaters regardless of whether the heater controls are in auto or manual. (This applies to essential and non-essential heaters.)

Enclosure 8 contains a simplified drawing of the pressurizer heater/DH11 and DH12 interlock.

PRESSURIZER SPRAY VALVE CONTROLS

The Pressurizer Spray Valve, RC-2, is controlled from HIS-RC2-1 on the RCS Makeup and Pressurizer Control Panel C5705. When in the "AUTO" position, the valve will cycle to the 40% open position when RC pressure exceeds 2205 psig and will remain open until pressure returns to 2155 psig.

The valve can be manually opened by placing the switch in the "OPEN" position. If the switch remains in the "OPEN" position, the valve will travel to the full open position and remain open regardless of how far RC pressure falls. If the switch is temporarily moved to "OPEN" and then returned to "AUTO" the valve will stay in the position it reached before it was returned to "AUTO". The valve will stay in this throttled position if the RC pressure remains between 2155 psig and 2205 psig. If RC pressure exceeds these limits, the valve will respond to the automatic controls.

If the switch is placed in the "CLOSE" position the valve will close and will remain closed regardless of how high RC pressure becomes.

An amber indicating light on the control panel comes on when the valve reaches the 40% open position, but if the valve is being opened manually, the light will go out when the valve reaches the 45% open position. If the valve is more than 45% open, it will not come on as the valve closes.

When the Pressurizer Spray Bypass Valve, RC 262, is fully open indicating light IL285 on Control Room panel C5705 will light.

POWER OPERATED RELIEF VALVE CONTROLS

The Power Operated Relief Valve (PORV) RC2A can be controlled by HIS-RC2-6 on RCS Makeup and Pressurizer Control Panel, C-5705.

The switch has an "OPEN" position with a spring return to the "AUTO" position; the valve will automatically open to relieve pressure to the Quench Tank when RC pressure exceeds 2425 psig and will close when RC pressure drops to 2375 psig.

The valve may be manually opened by placing the switch in the "OPEN" position. If the switch is held in the "OPEN" position, the valve will remain open. If the switch is released the valve will remain open until RC pressure falls below 2375 psig.

The valve may be manually closed by pushing the switch "IN", but a high pressure of 2425 psig will override and open the valve.

The valve may be held open manually by placing the switch in the "LOCK OPEN" position. The switch and valve will remain in the "OPEN" position until closed manually. To manually close the valve, the switch is pushed in, but a high pressure of 2425 psig will override and open the valve.

Position Indication: The blue light, ILRC2-6 on Panel C5705 signifies only that power is available to the PORV solenoid. Position indication for the PORV (red-green lights of HIS RC 2-6) is derived from a micro-switch actuated by the PORV solenoid/pilot valve lever. The amber light is lit when RC2-6 is placed in the "LOCK-OPEN" position. The pilot vents the PORV piston permitting RCS pressure to open the PORV. ILRC2-6 and HISRC2-6 do NOT indicate actual valve position. For positive flow indication, refer to the indicating lights and the position % open meters on panels C5798 and C5799. Computer annunciator alarm Z768 will alarm if any valve alarm modules actuate.

PRESSURIZER LEVEL CONTROL

The water level in the pressurizer is controlled by the opening/closing of the normal makeup flow controller valve (MU32). MU32 receives its control signals from the PRZR LEVEL H/A Station (LIC-RC14) on the Reactor Coolant Makeup and Pressurizer Control Console (C5705) in the control room. In order to automatically control pressurizer level, the operator must place LIC-RC14 in "AUTO" and adjust the setpoint dial to the desired value. LIC-RC14 then compares the temperature compensated level signal to the setpoint and develops a demand signal to MU32. (NOTE: The level signal to LIC-RC14 may be from LT-RC14-1, 2 or 3 as selected at HS-RC14 and may be temperature compensated by TE-RC15-1 or 2 as selected at HS-RC15). Manual control for MU32 is accomplished by placing LIC-RC14 in "HAND" and adjusting the demand signal to MU32 by means of the toggle switch. The indicator on LIC-RC14 will furnish the operator with the following information:

<u>MODE OF LIC RC14</u>	<u>INDICATOR SWITCH</u>	<u>INDICATOR SCALE</u>
Auto	Measured Variable	Auto balance (should indicate 50%)
Hand	Measured Variable	0-100% demand to MU-32
Auto	Position	0-100% demand to MU-32
Hand	Position	0-100% demand to MU-32

It should be noted that the temperature compensated level signal to LIC-RC14 is the same signal used for the pressurizer high/low level alarm, the pressurizer heater low-low level interlock, the pressurizer low-low level alarm and the pressurizer level indication on the PRZR LEVEL recorder (LRS-RC14) on C5705.

The vessel is protected from thermal effects by a thermal sleeve in the surge line connection and by a distribution baffle on the surge pipe inside the vessel.

To eliminate abnormal buildup or dilution of boric acid within the pressurizer and to minimize cooldown of the coolant in the spray and surge lines, a bypass flow is provided around the pressurizer spray control valve. This continuously circulates approximately 1 GPM of reactor coolant from the discharge of RCP 1-2-2.

A sampling connection to the liquid volume of the pressurizer is provided for determining the boric acid concentration. A steam space sampling line provides a capability for sampling and/or venting accumulated gases.

Each code safety relief valve discharges to containment atmosphere. The code safety relief valves are set at 2500 psig with setpoint tolerance of ± 25 psig. Each code safety relief valve has two rupture discs with a setpoint of 110 psig. Code relief valve leakage is routed to the quench tank via a 3/4" drain line between the relief valve and rupture disc. This drain line is connected to the quench tank eight inch inlet. Quench tank pressure must be maintained less than 90 psig to prevent blowing pressure relief valve RC207. Design pressure for the Quench Tank is 100 psig.

During cooldown, after the Decay Heat Removal System is placed in service, the Pressurizer can be cooled by circulating water through a connection from the discharge of a decay heat removal cooler to the pressurizer spray line. When the reactor coolant system pressure has been decreased sufficiently (~ 30 psig, 250°), the pressurizer steam bubble is replaced with a nitrogen bubble.

Design Conditions

Material	CS with SS cladding
Pressure	2500 psig
Temperature	670°F
Volume of Tank	1502 cu ft (11236 gal)
Volume per inch of Tank Height	24 Gallons
Level indication at top of heater bundles	24 inches
Spray Flow	190 gpm
Height	45 feet
Diameter	97 inches
Thickness	6.2 inches

Normal Operating Conditions

Pressure	2155 psig
Temperature	647°F
Level	200 inches
Bypass Spray Flow	1.0 gpm
Liquid Volume	889 cu feet
Gas Volume	702 cu feet
Electric Heater capacity	1638 KW

2. PRECAUTIONS AND LIMITATIONS

- 16 | 2.2 In conjunction with the PORV is RC-11, the Pressurizer Power Operated Relief Isolation Valve (or PORV Block Valve). The PORV Block Valve can be controlled by HIS-RC11 on RCS Makeup and Pressurizer Control Panel C-5705. During normal operation the PORV Block Valve should be open and the PORV should be in automatic. If required (such as PORV leaking, PORV controls inoperable, valve or NNI maintenance is in progress) the PORV Block Valve can be shut by the direction of the Shift Supervisor per AD 1839.00, "Station Operations". Extended power operation with the PORV Block Valve shut must be done only under the approval of the Station Superintendent. The PORV is utilized in various emergency and abnormal plant procedures for depressurization of the RCS, and under such circumstances, if possible the PORV Block Valve should be open to facilitate the procedure. 16 | No credit is taken, however, in Chapter 15 of the USAR for the PORV.
- 2.3 The pressurizer heatup and cooldown rates shall not exceed 100°F/hr as measured by temperature indicator TI RC 15 located in control room or by computer points T776 or T777.
- 2.4 Maximum pressurizer level at any time the reactor is critical is 290 in.
- 2.5 Minimum water level while reactor power is greater than 15% is 160 inches.

NOTE: This water level is the minimum pressurizer water level at which the system can accommodate a reactor trip without causing the pressurizer heaters to be de-energized by the pressurizer lo-lo level interlock (40").

- 16 | 2.6 Minimum pressurizer water level at any time the reactor is critical is shown on Figure 16. (Enclosure 4)

NOTE: This water level is the minimum pressurizer water level at which the system can accommodate a reactor trip without losing level indication.

- 2.7 The pressurizer must not be filled with water above 320 inches at any time.
- 2.8 Maximum pressurizer operating temperature is 670°F.
- 2.9 When the Reactor Coolant temperature is greater than 200°F, a minimum bypass spray flow of 0.75 GPM must be maintained.
- 2.10 Nitrogen injected into the pressurizer must not decrease the injection nozzle temperature more than 100°F.
- 2.11 Nitrogen injected into the pressurizer must not decrease the injection nozzle temperature below 100°F (NDTT + 60°F) if the RC pressure is above 550 psig.
- 2.12 The pressurizer spray shall not be used if the temperature difference between the pressurizer and the spray fluid is greater than 410°F. (Difference between computer points T774 and T776 or T777.)

(TS 2.13 Decay Heat Removal system relief valve DH-4949 shall be operable
3.4.2) with a lift setting of ≤ 330 PSIG* and isolation valves DH-11 and DH-12 open and control power to their valve operators removed. (Modes 4 and 5)

16 | (TS 2.14 Both pressurizer code safety valves shall be operable with a
3.4.3) lift setting of < 2525 psig. When not isolated, the pressurizer electromatic relief valve shall have a trip setpoint of ≥ 2390 . (Modes 1, 2, & 3)

(TS 2.15 The pressurizer shall be operable with a steam bubble and a
3.4.4) water level between 45 inches and 305 inches. (Modes 1 & 2)

16 | (TS 2.16 The pressurizer temperature shall be limited to: (Applicability
3.4.9.2) - At all times)

- a. A maximum heatup and cooldown rate of 100°F in any one hour period, and

- 16| b. A maximum spray water temperature differential of 410°F.
- 16| c. A minimum temperature of 120°F when the pressure is \geq 625 psig.

(TS 2.17 Reactor Coolant System leakage shall be limited to:
3.4.6.2)

- a. 1 GPM unidentified leakage (Modes 1, 2, 3 & 4).
- b. 10 GPM identified leakage from the RCS (Modes 1, 2, 3, & 4).

2.18 Pressurizer level indication is dependent on containment temperature. Because an elevated reference leg temperature causes the indicated level to be higher than the actual level, calibration curves must be used to correctly determine pressurizer inventory. These curves are given in Attachments 1-5 for compensated level and Attachments 6-10 for uncompensated level for reference leg temperatures of 68, 120, 150, 200, and 250°F as measured by indicators TI1356, TI1357, TI1358 or computer points T298, T302, or T306.

These corrections need be considered only under accident conditions which cause high containment temperature. Also note that steam generator and core flood tank level indications will be similarly affected by elevated containment temperature.

3. REFERENCES

- (TS) 3.1 Technical Specifications, Sections 3.4.2, 3.4.3, 3.4.4 and 3.4.9.2, 3.4.6.2
- 3.2 NSSS Limits and Precautions - PP 1101.01
- 3.3 Plant Shutdown and Cooldown, PP 1102.10
- 3.4 Plant Startup, PP 1102.02
- 3.5 Filling and Venting Reactor Coolant System, SP 1103.02
- 3.6 Draining and Nitrogen Blanketing Reactor Coolant System, SP 1103.11
- 3.7 Operational Chemical Control Limits, PP 1101.04
- 3.8 Gaseous Radioactive Waste System Operating Procedure, SP 1104.27
- 3.9 Hydrogen Addition and Degasification Procedure, SP 1102.12
- 3.10 Nitrogen Purge and Blanketing Procedure, SP 1104.26
- 16| 3.11 Pressurizer Systems Failures, AB 1203.19

- 3.12 Boron Concentration Control Procedure, SP 1103.04
- 3.13 Remote Shutdown Instrument Channel Calibration (Przr Lvl),
ST 5036.02
- 3.14 Quench Tank Operating Procedure, SP 1103.17
- 3.15 Nuclear Areas Sampling Procedure, SP 1104.10
- 3.16 Reactor Coolant System Piping and Instrument Diagram M-030 A/B
- 3.17 Reactor Coolant System Details P&ID M040A
- 17 | 3.18 Elementary Wiring Diagrams RCS, Drawing No. E52B, TED File No.
1949

4. PRESSURIZER OPERATION (STARTUP)

4.1 Prerequisites

- _____ 4.1.1 The Reactor Coolant System is filled, vented and pressurizer level is 80 inches or greater, as read on LRS RC 14 in control room, as per SP 1103.02, Filling and Venting the Reactor Coolant System, Section 5.
 - _____ 4.1.2 All combinations of the pressurizer temperature compensated levels read within 18 inches of each other or work requests have been submitted to initiate corrective action and open RC146*, Pzr Vent Line to Quench Tk. RC146 is locked valve, controlled per AD 1839.02.
 - _____ 4.1.3 Power is available to pressurizer instrumentation and controls and pressurizer heater bank circuit breakers, or work requests have been submitted to correct deficient items. (See Enclosures 1 and 2)
- NOTE: Power must be available to all essential heaters.
- _____ 4.1.4 RC System valves associated with pressurizer operation are positioned in accordance with Valve Verification List A of this procedure.
 - _____ 4.1.5 Containment Equipment Vent Header, Reactor Coolant Drain Tank, Gaseous Radioactive Waste System and Sampling System are operational to allow venting of the pressurizer steam space.
 - _____ 4.1.6 Boron concentration has been equalized between the pressurizer and the Reactor Coolant System by using

Pressurizer Spray Valve RC 2 or the normally throttled Bypass Valve, set at 1 to 3 GPM.

NOTE 1: When Reactor Coolant Pumps are not operating, the Decay Heat System will be used to provide pressurizer spray by opening valves DH 2735* and DH 2736*, from DH Pump Discharge to pressurizer spray line. DH 2735 and DH 2736 are locked valves, controlled per AD 1839.02.

NOTE 2: Limits on boron concentration between the pressurizer and RCS should be <50 ppmB. Reference PP 1101.01, Section 1.3.3.11.

- 17 |
- ___ 4.1.7 The RCS pressure is at 30 to 50 psig with a nitrogen blanket.
 - ___ 4.1.8 Quench Tank operable as per Quench Tank Operating Procedure, SP 1103.17.
 - ___ 4.1.9 Ensure the N₂ System to PRZR Vent Isolation Valve, NN64 is closed.

4.2 Procedure

NOTE: Use in conjunction with Startup Procedure, PP 1102.02.

- 17 |
- ___ 4.2.1 Establish a vent path from the pressurizer vapor space to the pressurizer quench tank by performing Valve Lineup List F, PRZR Vent Path for Steam Bubble Formation, per PP 1102.02, Plant Startup Procedure.
 - ___ 4.2.2 Unlock RC147* and station an Operator in Containment at RC147*, pressurizer vent throttle valve, with communications established to the Control Room. RC147 is a clocked valve, controlled per AD 1839.02.
 - ___ 4.2.3 From the Control Room, on the RCS Makeup and Pressurizer Control Panel, C5705, turn on the pressurizer heaters to begin increasing pressurizer temperature for forming a steam bubble. Monitor pressurizer temperature on TI RC15 and RC pressure on RCS wide range recorder RC 2A1 or RCS low range pressure PI-RC2A6. Pressurizer heater controls and heater bank sizes are listed below. Manipulate heaters to maintain a pressurizer heatup rate of 100°F/hr.

(See Enclosure 3, Pressure and Temperature Limitations for Heatup)

17 |

<u>Group</u>	<u>Controller</u>	<u>Size</u>
SCR	PIC RC 2	126 KW
2	HIS RC 2-2	280 KW
2A (Essential 1)*	HIS RC 2-A	126 KW
3	HIS RC 2-3	280 KW
4	HIS RC 2-4	434 KW
2B (Essential 2)*	HIS RC 2-B	126 KW

*Essential Heater Banks 1 or 2 are also referred to as Heater Banks 2A or 2B respectively.

NOTE: Heat input from the SCR group can be controlled between minimum and maximum with PIC RC2. The remaining groups will be either full on full off.

CAUTION: Refer to PP 1101.04, Operational Chemical Control Limits, Section 4.4.1, Dissolved Oxygen, do not exceed 250°F unless Chem Lab has verified by sample the CL⁻ and F⁻ are 0.1 ppm from pressurizer liquid space sample. This is to allow 60 hours to get dissolved oxygen in spec.

4.2.4

When pressurizer pressure exceeds 50 psig, begin venting nitrogen to the quench tank by throttling RC147*. Operate pressurizer heaters as necessary to maintain RCS pressure between 50 and 100 psig. Venting can be stopped by closing RC 200 from Control Room. RC147 is a locked valve, controlled per AD 1839.02.

NOTE: Early in the venting process most of the gas vented to the quench tank will be nitrogen. Manual operation (from Control Room) of RC 222 Quench Tank Vent to Containment vent header will be required to keep quench tank pressure below 50 psig. As the venting process continues, level and temperature control of the quench tank will be required to handle the condensed steam.

4.2.5

Throttle RC147* or close RC 200 as necessary to keep quench tank pressure below 50 psig. RC147 is a locked valve, controlled per AD 1839.02.

4.2.6

Cycle the pressurizer heaters to maintain RCS pressure between 50 and 100 psig. The SCR controlled heaters can be used for fine pressure control.

4.2.7

Open RC240A and RC240B, Pressurizer Sample Line

Containment Isolation Valves from the Control Room on SFAS Panel C5717, use switches HIS 240A and HIS 240B to Reactor Sample System Panel C1705. C&HP will periodically sample the pressurizer liquid space to determine if venting is complete. RC 239A must be closed and RC 239B must be opened to allow sampling the pressurizer liquid space.

NOTE: The purpose of venting is to remove nitrogen from the vapor space and to reduce dissolved oxygen in the liquid. Dissolved oxygen must be <100 ppb within 60 hours after exceeding 250°F or the pressurizer must be cold at the end of this 60 hour period.

- 17 | _____ 4.2.8 When venting is complete, perform the following:
- _____ 1. Complete Valve Lineup List G Returning PRZR Vent Lineup to Normal per PP 1102.02, Plant Startup Procedure.
 - _____ 2. Close RC 240A and RC 240B, Pressurizer Sample Line Containment Isolation Valves, from the Control Room when C&HP determines that sampling is no longer required.
- _____ 4.2.9 Continue reactor coolant pressurization in accordance with PP 1102.02, Plant Startup Procedure.

NOTE: At about 500 PISG the pressurizer heat tracing to the Power Operated Relief Valve will be energized. This is done by closing breakers 9 and 11 in panel DP 4502 and breaker for circuit 1P in panel DP 4602.

- _____ 4.2.10 Place the pressurizer level indicator controller (LIC-RC14) in automatic mode and adjust the setpoint for 75 inches.

NOTE: Setpoint will be increased as necessary as per PP 1102.02, Plant Startup Procedure.

- _____ 4.2.11 When the Reactor Coolant System reaches approximately 1900 PSIG, place the pressurizer heaters and spray valve in automatic mode.
- _____ 1. For heaters: Place switches HIS-RC 2-2, 2-3 and 2-4 in "AUTO" for heater banks 2, 3, and 4, respectively; and HIS-RC2A & B in "AUTO" for heater banks 2A & 2B (See 5.2.1 Note) and place PIC-RC2 in AUTO for SCR heaters.
 - _____ 2. For pressurizer spray place switch HIS-RC2-1 in AUTO position.

- ___ 3. For pressurizer power relief place switch HIS-RC2-6 in AUTO position.

NOTE: All switches above located in Control Room on Panel C5705, left console.

- ___ 4.2.12 Observe that the heater banks shutoff when they reach their respective setpoints: (This will be indicated by the "ON" or "OFF" lights on their respective switches.) See Enclosure 7 for setpoints.

Section 4 Completed by _____ Date _____

5. NORMAL OPERATION

Signoffs are not required for this section.

5.1 Prerequisites

- ___ 5.1.1 Quench Tank in operation in accordance with SP 1103.17, Quench Tank Operating Procedure.

5.2 Procedure

- ___ 5.2.1 Observe that the pressurizer heater bank automatic control operates at the setpoints listed on Enclosure 7 of this procedure.

NOTE: If power is lost to Banks 2A or 2B (even momentarily), while hand switches are in AUTO, these banks will not come on until the operator places the switches in the ON position to re-energize them. The purpose of this interlock is to prevent this load from being powered from the Diesel Generators if not required.

- ___ 5.2.2 Observe that the pressurizer spray valve (RC 2) automatic control operates at the setpoints of 2205 PSIG valve opens and 2155 PSIG valve closes. The "ON" and "OFF" lights on switch HIS RC2-1 will indicate proper operation of automatic control.

NOTE: If this valve was to fail open, it would cause depressurization below 2155 PSIG. RC 10 would have to be closed to isolate it. Closing this valve would also stop mini-spray RC 49.

- ___ 5.2.3 At least once a day check code safety relief valves and PORV for valve leakage by using the computer points listed for above normal temperatures.

T 773 PORV, RC2A
 T 010 RC 13B
 T 011 RC 13A

5.2.4

Observe that the PORV (RC2A) control power is available (blue light on console LIT). With HIS-RC2-6 in AUTO, the valve will open at 2425 PSIG and close at 2375 PSIG. The open and closed lights on the console indicate the position of the pilot valve on the power relief. Positive indication of flow through RC2A will be shown by lights and % position meters on panel C5798 and C5799. Computer annunciator alarm Z768 will alarm if any valve alarm modules actuate.

NOTE: If this valve were to fail open, it would cause depressurization of the RCS. This failure would be further indicated by increasing Quench Tank pressure and a high RC2A outlet temperature observed on T773. In this condition, RC11 would have to be closed to isolate RC2A.

17 |

5.2.5

Sample the pressurizer water space weekly as per Nuclear Areas Sampling Procedure, SP 1104.10, Section 5.2. If C&HP has determined that the pressurizer needs to be vented due to excessive non-condensables in the pressurizer steam space, vent by one of the following methods.

There are two acceptable methods for venting the pressurizer. The preferred method is to vent the pressurizer to the RC Drain Tank through the Sampling System. The alternate method would be to vent the pressurizer to the Pressurizer Quench Tank.

Method I - Venting Pressurizer to RC Drain Tank

1. Open sample system return isolation valve to RC Drain Tank, SS 808.
2. Position pressurizer sample lines/RCS Cold leg sample line as follows.
 1. Open RC 240A using HIS 240A on C5717 (SFAS)
 2. Open RC 240B using HIS 240B on C5717 (SFAS)
 3. Check closed RC4632 using HIS 4632 on C5705
3. Open pressurizer vapor sample valve RC 239A from the control room, panel C5705, Left console, using switch HIS 239A and vent to the letdown line by the normal sampling recirc path - SP 1104.10 (Sample System Nuclear Areas Sampling Procedure).

- ___ 4. Vent continuously until C&HP has determined non-condensable gases have been removed.
- ___ 5. When venting is completed, return all valves back to normal: Close SS 808, RC 240A, RC 240B, RC 239A.

Method II - Venting Pressurizer to Quench Tank

- ___ 1. Open RC 200, Pressurizer vent to Containment Vessel header.
- 17 | ___ 2. Open RC 146*, Pressurizer vent to quench tank. RC 146 is a locked valve, controlled per AD 1839.02.
- ___ 3. Check closed RC 4632, using HIS 4632 on C5705, RCS coldleg sample line.
- ___ 4. Close manual isolation valve RC 198 for Containment Vent Header, and pressurizer vent throttle valve RC 147* and RC5007* then open RC5006. RC 5007 and RC 147 are locked valves, controlled per AD 1839.02.
- 17 | ___ 5. Open pressurizer vapor sample valve RC 239A from Control Room on Panel C5705, left console, using switch HIS 239A.
- ___ 6. Open slowly pressurizer vent throttle valve RC 147*. RC 147 is a locked valve, controlled per AD 1839.02.
- ___ 7. Vent continuously to quench tank until C&HP has determined noncondensable gases have been removed. Vent from quench tank to containment vent header using RC 222.

CAUTION: Do not exceed design pressure of CTMT Vent Header (50 psig) Monitor pressurizer quench tank for proper level, temperatures and pressure control.

- ___ 8. When venting is completed, return all valves back to normal.

- ___ 5.2.6 Equalize the boron concentration in the pressurizer with the RC System whenever there is a difference of greater than 50 ppm boron concentration.

NOTE: During normal operations, the concentration of boric acid in the pressurizer water compared to RCS is not expected to be a significant problem because the boric acid in the reactor coolant changes slowly with time and there is a continuous flow of about

1.5 GPM through the spray line allowing water to recirculate slowly between the pressurizer and the main reactor coolant stream. The problem is expected to be more critical during startup from a cold condition (especially after refueling) when the boric acid in the coolant is rapidly changed. During such periods, the spray flow should be increased so that the rate of recirculation is increased. During normal operations, an analysis should be made once a week. During startup periods, an analysis should be performed when the reactor is critical and once every shift thereafter for several days.

- _____ 1. Open pressurizer spray valve RC 2 from Control Room using switch HIS RC2-1.

CAUTION: Continue to spray, as long as pressurizer heaters are able to maintain RCS pressure near normal operating pressure (2155 psig).

- _____ 2. Continue pressurizer spray until at least one volume of the pressurizer (4800 gal. at normal level of 200") has been changed. This will take about 30 minutes to complete at a pressurizer spray flow of 160 GPM.

- _____ 3. Stop pressurizer spray and allow pressurizer pressure and level to settle out and then have C&HP take another sample. If boron concentration of pressurizer and RCS is not within ± 50 ppm, repeat Steps 1 and 2 until the limit is reached.

- _____ 4. After pressurizer and RCS boron concentration is equalized, ensure spray valve is in "AUTO" and level and pressure of pressurizer are back to normal (200" and 2155 psig).

- _____ 5.2.7 Perform a channel check each shift of all pressurizer level indication. This is done to satisfy TS 4.4.4 Surveillance Requirements which state: The pressurizer shall be demonstrated OPERABLE by verifying pressurizer level to be within limits at least once per 12 hours.

NOTE: These will be checked by Miscellaneous Instrumentation Shift Check Procedure, ST 5099.01.

- _____ 5.2.8 If ISI or RCS hydro walkdowns are to be performed, manually control the pressurizer heaters and spray valve, to increase pressure to 2195 PSIG. Maintain >2195 PSIG during the performance of the ISI or RCS

hydro walkdown, then return pressure back to 2155 psig. The pressurizer heaters and spray valve can then be returned to Auto.

6. DEPRESSURIZATION (SHUTDOWN/COOLDOWN)

This section will be used in conjunction with SP 1102.10, Plant Shutdown and Cooldown.

6.1 Prerequisites

- ___ 6.1.1 The reactor coolant system is in a hot standby condition as per Plant Shutdown and Cooldown Procedure, SP 1102.10, Section 4.0.
- ___ 6.1.2 Pressurizer has been degassed prior to cooldown and depressurization as per Hydrogen Addition and Degasification Procedure, SP 1102.12, Section 7.0.

NOTE: Degassing may be needed during cooldown.
- ___ 6.1.3 Pressurizer level indicator controller (LIC-RC14) is in Automatic and set to maintain level at 220 inches.
- ___ 6.1.4 Pressurizer spray valve RC 2 is in automatic.
- ___ 6.1.5 Pressurizer heaters are in "AUTO" maintaining normal operating pressure.

6.2 Procedure

NOTE: Use in conjunction with Plant Shutdown and Cooldown Procedure, PP 1102.10.

- ___ 6.2.1 De-energize all pressurizer heaters by turning the following switches to "OFF", located in the control room on panel C5705, left console:
 - ___ 1. Place HIS-RC2-2 to OFF for Heater Bank 2
 - ___ 2. Place HIS-RC2-3 to OFF for Heater Bank 3
 - ___ 3. Place HIS-RC2-4 to OFF for Heater Bank 4
 - ___ 4. Place HIS-RC2A to OFF for Essential Heater Group 1
 - ___ 5. Place HIS-RC2B to OFF for Essential Heater Group 2
 - ___ 6. Place PIC-RC2, Pressure Heater Control for SCR Heater Bank, in Manual and reduce setpoint to zero.
- ___ 6.2.2 Manually control the pressurizer spray valve RC-2, to cool the pressurizer, by turning control switch HIS-RC2-1 to the "ON" position, in the control room on panel C5705, left console. Cycle the pressurizer spray to maintain a cooldown rate as per pressure vs

temperature limitations for cooldown, Figure 2 of NSSS Limits and Precautions, PP 1101.01.

- 12 |
- ____ 6.2.3 Monitor RCS pressure on RCS wide range recorder RC 2A1 or RCS low range pressure indicator PI-RC2A6 and pressurizer temperature on TI RC15 located on panel C5705, left console, in the control room. Plot the data on RCS pressure vs temperature limitations curve, Enclosure 5.
- NOTE: Heaters may be re-energized to maintain pressure, but should not be required.
- ____ 6.2.4 Maintain pressurizer level at 220 inches to ensure sufficient Reactor Coolant Volume is available for contraction during cooldown.
- ____ 6.2.5 If required during cooldown to 280°F, vent the pressurizer through the sampling system line to the reactor coolant drain tank. Complete Step 5.2.5 Method I of this procedure, for venting pressurizer to the reactor coolant drain tank.
- ____ 6.2.6 When the RC system pressure is between 350 psig and 600 psig, slowly begin to decrease pressurizer to 60 inches by lowering the setpoint on pressurizer level indicator controller (LIC-RC14) on panel C5705, left console.
- NOTE: This will allow for the removal of the large volume of hot reactor coolant from the pressurizer for further cooling down of RCS and pressurizer before decay heat removal is initiated.
- ____ 6.2.7 Continue to decrease RCS pressure to 350 psig by spraying the pressurizer as necessary by using Spray Valve RC-2 and while maintaining pressurizer level at 60 inches.
- ____ 6.2.8 Continue to decrease the RCS pressure to less than 310 psig, by increasing spray flow if necessary to allow Decay Heat Removal System to be placed in service.
- ____ 6.2.9 Place pressurizer level indicating controller (LIC-RC14) in manual on panel C5705, left console, and establish a 25 inch per hour increase in pressurizer level, as read on pressurizer level recorder LRC-RC14 on panel C5705, left console.

____ 6.2.10 When the Decay Heat Removal System is in operation and Reactor Coolant Pumps are shutdown, close pressurizer spray valve RC2, using switch HIS-RC2-1, on panel C5705, left console.

____ 6.2.11 Open pressurizer auxiliary spray stop valve, DH 2735, using switch HIS 2735, on panel C5705, left console.

____ 6.2.12 Slowly open the auxiliary spray throttle valve DH 2736, using switch HIS 2736 on panel C5705, left console, to the pressurizer until a temperature increase in the pressurizer surge line is detected as read on computer point T775. Adjust the auxiliary spray throttle valve (in the close direction) until the temperature returns to its previous value.

NOTE 1: Do not exceed a cooldown rate of 100°F per hour in the pressurizer.

NOTE 2: This spray adjustment is to prevent pressurizer outsurge into the RC hot leg. The pressurizer surge temperature should be monitored closely throughout the continuation of cooldown. If the surge line temperature increases again adjust the auxiliary spray throttle valve (in the close direction) until the temperature returns to its previous value.

____ 6.2.13 When the RC System pressure is less than 125 psig, stop pressurizer level increase at 280 inches as read on pressurizer level recorder LRS-RC 14 on Panel C5705, left console.

16|

____ 6.2.14 When the RC System is at 30 psig and less than 250°F, start adding nitrogen in the pressurizer while quenching the steam bubble by completing the following steps:

- ____ 1. Place pressurizer nitrogen heaters in service per Section 8.1 of SP 1104.37, Freeze Protection and Electrical Heat Tracing Systems.

CAUTION: Nitrogen injected into the pressurizer must NOT decrease the injection nozzle temperature more than 100°F.

- ____ 2. Ensure RC 240A, pressurizer sample line isolation, and RC 200, pressurizer vent to containment vent header, are closed.

16|

- ____ 3. Open NN64, N₂ System to pressurizer vent isolation valve.

4. Throttle open RC 239A, pressurizer vapor phase sample line isolation from the Control Room on Panel C5705, left console, using switch HIS 239A to maintain 25-30 psig in the pressurizer.

CAUTION: Spray valve operation with nitrogen in the pressurizer will require subsequent venting of the RC System.

16 | NOTE 1: To keep the hot legs filled solid with water maintain 25-30 psig nitrogen in the pressurizer.

16 | NOTE 2: Pressurizer level may be allowed to decrease from the 280 inch level, but maintain level above 85 inches.

- 6.2.15 Continue cooldown of RCS to $\leq 140^{\circ}\text{F}$ by decay heat removal and by continuing spraying of the pressurizer. At 140°F RC System temperature, cooldown is considered complete.

Section 6 Completed by _____ Date _____

7. CALCULATION OF TEMPERATURE - COMPENSATED PRESSURIZER LEVEL

16 | 7.1 It is desirable to periodically check the pressurizer temperatures - compensated level indication (LRS-RC14) against the pressurizer uncompensated level indications (LI-RC14-3 and LI-RC14-4) and uncompensated level computer points (L772, L773 and L774). Figure 1 gives the conversion between compensated and uncompensated level, assuming the pressurizer temperature is 647.4°F (saturation temperature at 2155 psig) and the reference by temperature is 68°F .

7.2 The pressurizer level transmitters are calibrated to read correct level when pressurizer water and reference leg water temperatures are 68°F with nitrogen pressure in the pressurizer at 60 psig. Using this information, the following equation can be developed:

$$L_{\text{UNC}} = 320'' \frac{1}{62.13} \left[\frac{320}{V_{\text{ref leg}}} - \frac{X}{V_{\text{H}_2\text{O}}} - \frac{(320 - X)}{V_{\text{steam}}} \right]$$

where L_{UNC} is uncompensated pressurizer level indication in inches

$V_{\text{ref leg}}$ is the specific volume of water in the transmitter reference legs in ft^3/lb

X is the actual (compensated) pressurizer level in inches, and

V_{H_2O} is the specific volume of water in the pressurizer in ft^3/lb

V_{Steam} is the specific volume of steam in pressurizer in ft^3/lb

FIGURE 1
ACTUAL VS. INDICATED
PRESSURIZER LEVEL

AT NORMAL OPERATING PRESSURE - 2155 PSTG

TSAT = 647.4°F

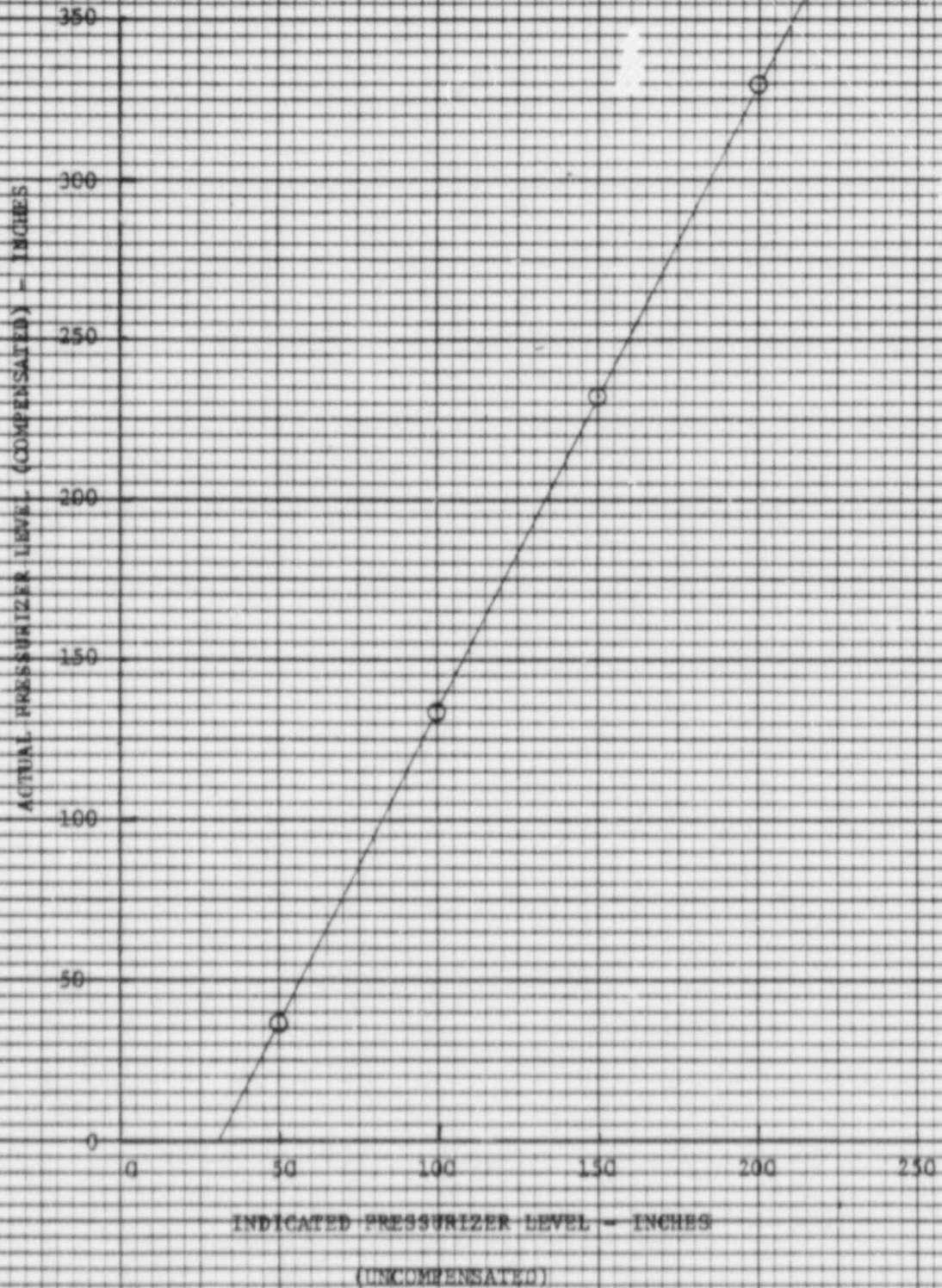

Océ-Elliott Inc.

FFRCH® 10453 - 10 10 X 10 TO 1 INCH

Equipment Identification No.	RC 2	RC 10	RC 11	RC 239A	RC 200	RC 240A	RC 240B	RC 239B	RC 2A
Equipment Name	Pressurizer Spray Valve	Pressurizer Spray Iso Valve	Pressurizer Power Relief Iso Valve	Pressurizer Vapor Phase Sample Iso Vlv	Press Sample Line to CTMT Vent Hdr Vlv	Press Sample Line Iso Vlv	Press Sample Line Iso Valve	Press Liquid Phase Sample Iso Valve	PORV (Power Operated Relief Valve)
Control Room	HIS-RC2-1	HIS-RC10	HIS-RC11	HIS-RC239A	HIS-RC200	HIS-RC240A	HIS-RC240B	HIS-RC239B	HIS-RC 2-6
Switch/Panel #	C5705	C5705	C5705	C5705	C5705	C5717	C5717	C5705	C5705
Control Room	RC Przr Auto Spray Valve	RC Przr Spray Iso Valve	Przr Electro Mag Relief Iso Vlv	Przr Vapor Sample Iso Valve	Przr Vent To CTMT Vent Hdr	Przr Sample Iso Valve	Przr Sample Iso Valve	Przr Liquid Sample Iso Valve	Przr Electro Mag Relief Valve
Breaker No. & MCC	BF 1260 F 12B	BE 1129 E 11A	BE 1602 E 16B	BF 1126 F 11A	BF 1285 F 12A	BE 1181 E 11B	BF 1128 F 11A	BF 1127 F 11A	RC 3716 (Powered from DBP30) Circuit 5R
MCC Location (Room number)	Diesel Gen Room 2 Room 319	By BWST Htr Room 209	#1 Elec Penet Room Room 402	North End of #2 Elect Penet Room Room 427	East Side of #2 Low Volt Swgr Rm	Next to Fuel Handling Area Room 304	North End of #2 Elect Penet Room Room 427	North End of #2 Elect Penet Room Room 427	Near MCC F21A (Room 310)
Local Control Switch No.	NV RC 2 at MCC F 12B	NV RC 10 at MCC E 11A	NV RC 11 at MCC	NV RC 239A at MCC F 11A	NV RC 200 at MCC F 12A	NV RC 240A at MCC E 11B	NV RC 240B at MCC F 11A	NV RC 239B at MCC F 11A	N/A
S. A. Signals	None	None	None	None	None	SA 271E	SA 272D	None	None

PRESSURIZER HEATER POWER SUPPLIES

	HEATER BANK	MCC	BRKR NO.	PRZR HTR PANEL BRKR/SWITCH	PZR HTR
17	PIC RC 2 SCR Controlled Heater Bank 126KW	F 62 East Wall #2 Elec- trical Penetration Room	BF 6203	BPH4-05 BPH4-06 BPH4-08	LB-9-1,9-2,6-2 LB-7-1,7-2,7-3 LB-8-1,8-2,5-1
17	RC Pressurizer Bank 2 Heater 280KW	E61 East Wall #2 Elec- trical Penetration Room	BE 6102	BPH5-01 BPH5-02 BPH5-03	UB-4-1,4-2 UB-5-3 UB-6-3
17			BE 6103	BPH5-05 BPH5-06 BPH5-08	UB-7 UB-8-1,8-2,3-1 UB-9-1,9-2
17			BE 6104	BPH5-09 BPH5-10 BPH5-11	UB-10 UB-11-1,11-2 UB-12
17	Pressurizer Essen Heater Bank 1 126KW	E12A #1 Low Voltage Switchgear Room	BE 1223	BE 1213 SE 1214 BE 1215	MB-1 MB-2-1,2-3,4-1 MB-3
17	RC Pressurizer Bank 3 Heater 280KW	E62 East Wall #2 Elec- trical Penetration Room	BE 6202	BPH3-01 BPH3-02 BPH3-03	UB-13 UB-2 MB-11
17			BE 6203	BPH3-05 BPH3-06 BPH3-08	Spare Spare MB-4-2,4-3
17			BE 6204	BPH3-09 BPH3-10 BPH3-11	MB-5 MB-6 MB-7

HEATER BANK	MCC	BRKR NO.	PRZR HTR PANEL BRKR/SWITCH	PZR HTR
17 RC Pressurizer Bank 4 434KW	F-61 East Wall #2 Elec- trical Penetration Room	BF 6103	BPH6-06 BPH6-08	MB-12 MB-13
		BF 6104	BPH6-09 BPH6-10	LB-1 LB-2
		BF 6102	BPH6-01 BPH6-02 BPH6-03	MB-8 MB-9 MB-10
17	F-62 East Wall #2 Elec- trical Penetration	BF 6202	BPH4-01 BPH4-02 BPH4-03	LB-3 LB-4-2,4-3 LB-5-2,5-3
		BF 6204	BPH4-09 BPH4-10	Spare LB-10
17 Pressurizer Essential Heater Bank 2 126KW	F-12-A #2 Low Voltage Switchgear Room	BF 1217	BF-1213 BF-1214 BF-1215	LB-11 LB-12 LB-13

NOTE: Each pressurizer heater is physically 3 (three) heater elements with a total heat capability of 42 KW.

PRESSURE and TEMP LIMITATIONS FOR HEATUP

- Curve
A-E-Z-Y Maximum pressure for heatup based on DTI-134^oF
- Maximum RCS pressure for decay heat system operation with RC pump combinations as follows:
- G-H No RC Pumps
 - J RC pump combinations (0 pumps-Loop 2, 1 pump-Loop 1), (0 pumps-Loop 2, 2 pumps-Loop 1), (1 pump-Loop 2, 0 pumps-Loop 1), (1 pump-Loop 2, 1 pump-Loop 1) and (1 pump-Loop 2, 2 pumps-Loop 1)
 - K RC pump combinations (2 pumps-Loop 2, 0 pumps-Loop 1) and (2 pumps-Loop 2, 1 pump-Loop 1)
 - L Required RC pump suction for combinations: RC pump combinations (0 pumps-Loop 2, 2 pumps-Loop 1), (2 pumps-Loop 2, 2 pumps-Loop 1) and (1 pump-Loop 2, 2 pumps-Loop 1)
 - M RC pump combinations (2 pumps-Loop 2, 0 pumps-Loop 1), and (2 pumps-Loop 2, 1 pump-Loop 1)
 - O-P-R RC pump combinations (1 pumps-Loop 2, 1 pump-Loop 1), (1 pump-Loop 2, 1 pump-Loop 1), and (1 pump-Loop 2, 2 pumps-Loop 1)
 - F-H Minimum NPSH for RC pumps - all combinations
 - S-Z-T Minimum pressure vs. temp. to maintain fuel in compression
 - V-W Minimum pressure vs. temp. to prevent boiling at top of hot leg.

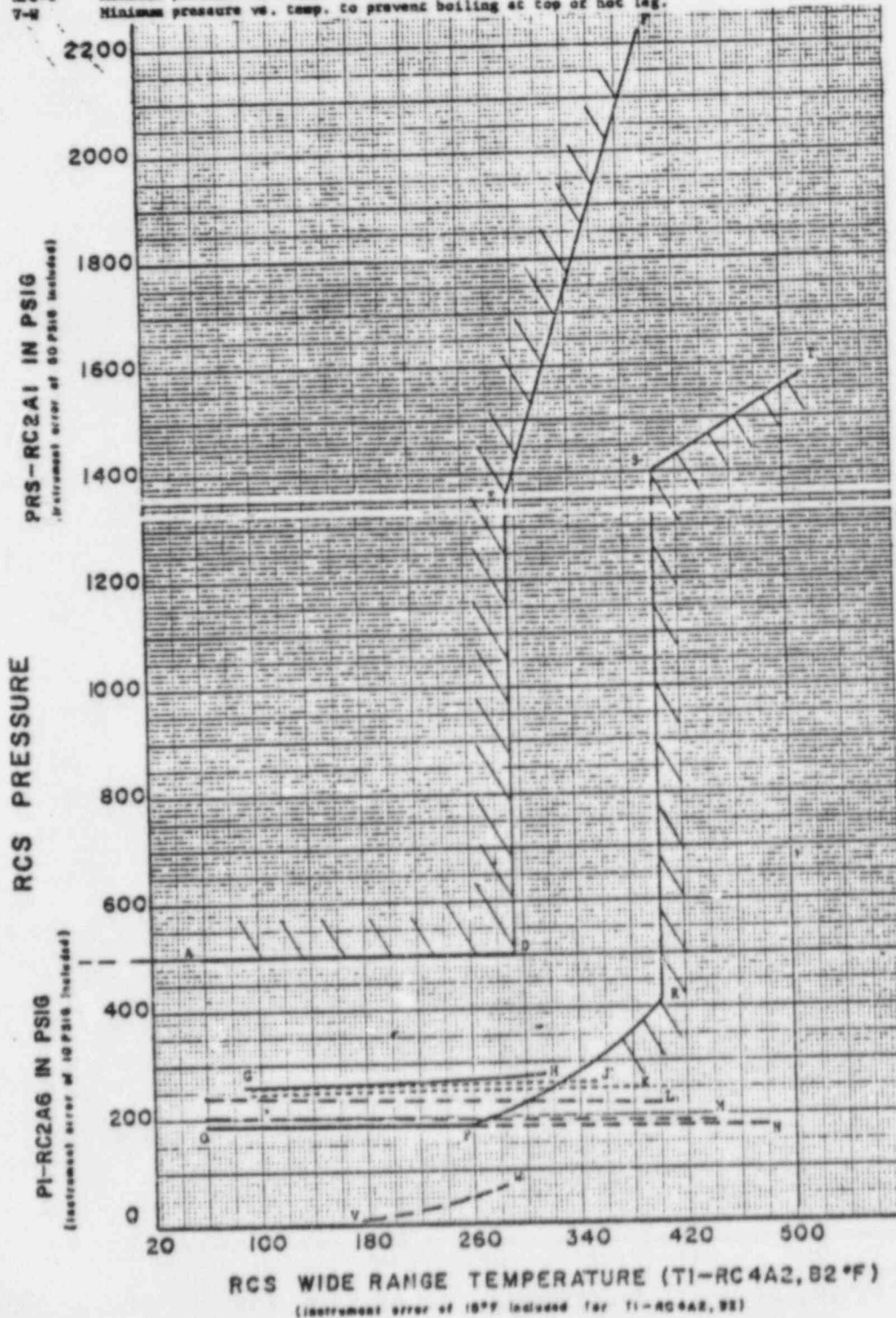

MINIMUM PRESSURIZER LEVEL vs RC TEMPERATURE

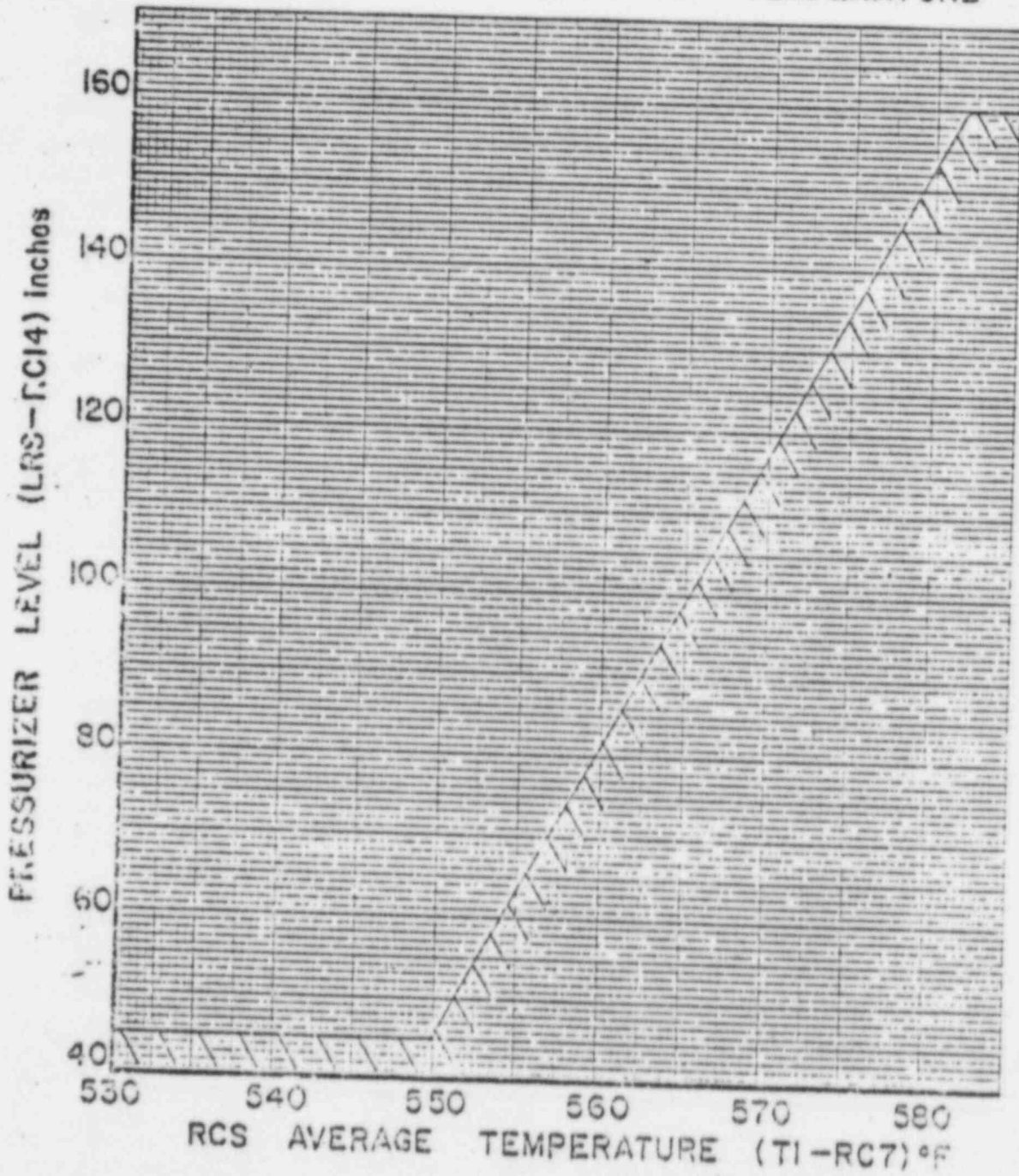
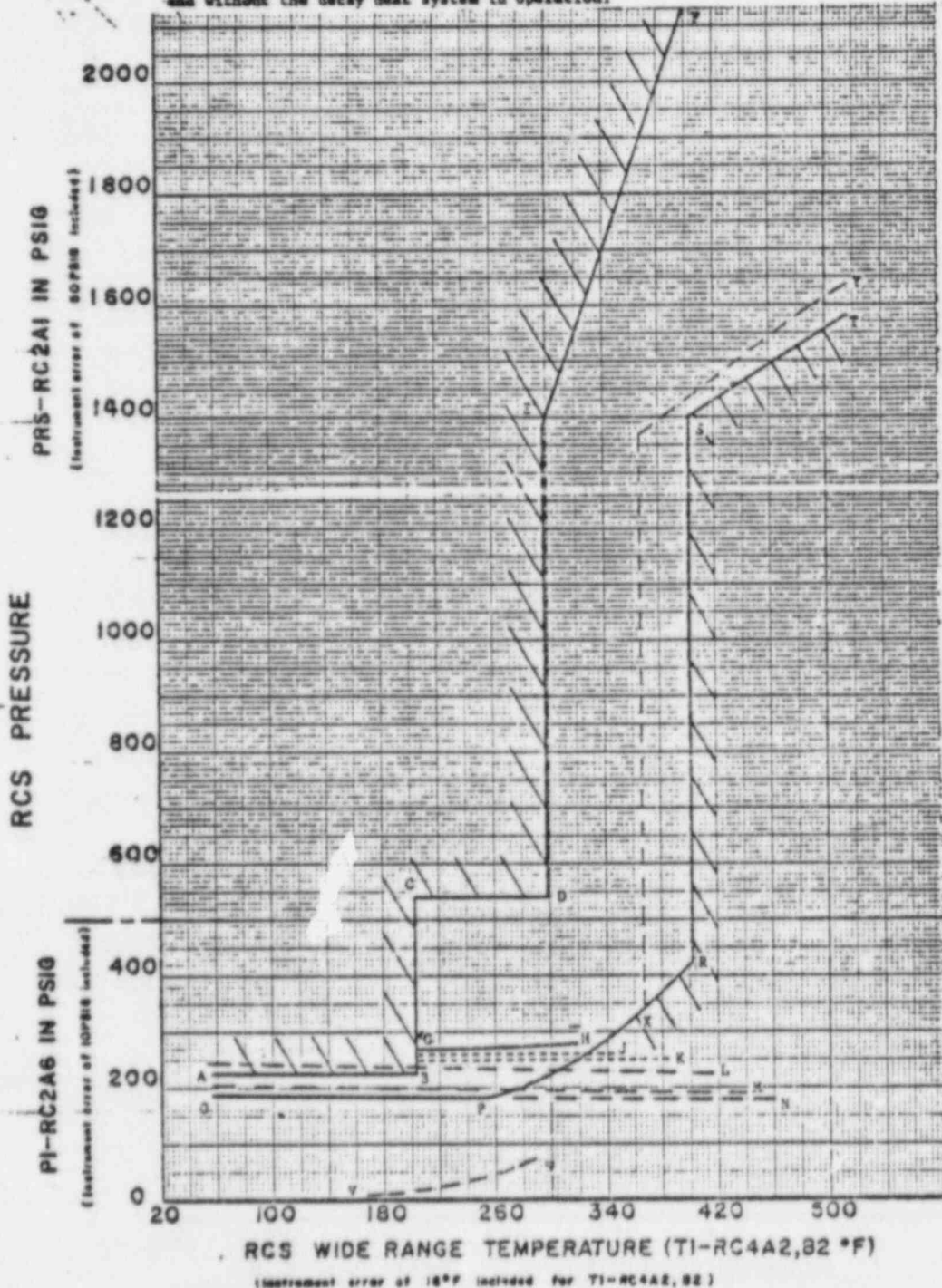

Figure 16

PRESSURE and TEMP. LIMITATIONS FOR COOLDOWN

- Curve A-B-C-D Maximum pressure for cooldown based on DTG-175°F
- E-F Maximum RCS pressure for decay heat system operation with RC pump combinations as follows:
- G-H No RC Pumps
- J RC pump combinations (0 pumps-Loop 2, 1 pump-Loop 1), (0 pumps-Loop 2, 2 pumps-Loop 1), (1 pump-Loop 2, 0 pumps-Loop 1), (1 pump-Loop 2, 1 pump-Loop 1) and (1 pump-Loop 2, 2 pumps-Loop 1)
- K RC pump combinations (2 pumps-Loop 2, 0 pumps-Loop 1) and (2 pumps-Loop 2, 1 pump-Loop 1)
Required RC pump suction for combinations:
- L RC pump combinations (0 pumps-Loop 2, 2 pumps-Loop 1), (2 pumps-Loop 2, 2 pumps-Loop 1) and (1 pump-Loop 2, 2 pumps-Loop 1)
- M RC pump combinations (2 pumps-Loop 2, 0 pumps-Loop 1), and (2 pumps-Loop 2, 1 pump-Loop 1)
- O-P-R RC pump combinations (0 pumps-Loop 2, 1 pump-Loop 1), (1 pump-Loop 2, 1 pump-Loop 1), and (1 pump-Loop 2, 0 pumps-Loop 1)
- Q-T Minimum NPSH for RC pumps - all combinations
- S-U-T Minimum pressure vs. temp. to maintain fuel in compression
- V-W Minimum pressure vs. temp. to prevent boiling at top of hot leg.
- X-Y Minimum pressure vs. temp. to maintain fuel in compression with no RC pumps running and without the decay heat system in operation.



VALVE VERIFICATION LIST A

Enclosure 6
Pressurizer (Normal Operation)

Verification List Only - Consult Shift Supervisor Prior to Repositioning Valve

M-030

17

VALVE DESCRIPTION	P&ID No. Coord.	VALVE NUMBER	VALVE POSITION	VERIFY BY	IND. VER. BY
Purge Line Drain Isolation	D-5	RC 55	Closed		
Purge Line Drain Stop Valve	D-5	RC 56	Closed		
Pressurizer Spray Header Inlet Manual Iso	C-11	RC 48	Open		
Pressurizer Spray Valve	C-10	RC 2	Closed		
Pressurizer Mini Flow	C-10	RC 49	Normally Throttled		
Pressurizer Spray Motor Isolation	C-9	RC 10	Open		
Pressurizer Spray Hdr Outlet Manual Iso	C-9	RC 50	Open		
Pressurizer Spray Valve Bypass	C-10	RC 262 ¹	Closed		
Pressurizer Electromagnetic Relief Iso	B-4	RC 11	Open/Closed per Shift Supervisor		
Pressurizer Electromagnetic Relief	A-3	RC 2A	Closed		
Pressurizer Vapor Phase Sample Line Iso	B-3	RC 239A	Closed		
Pressurizer Liquid Phase Sample Line Isolation	D-3	RC 239B	Closed		
Pressurizer Sample Line Vent Valve	B-3	RC 52	Closed		
Pressurizer Sample Line Isolation	B-2	RC 240A	Closed		
Pressurizer Sample Line Stop Valve	B-1	RC 240B	Closed		
Pressurizer Sample Line Drain	C-2	RC 53	Closed		
Pressurizer Sample Line Drain	C-1	RC 54	Closed		
Pressurizer Vent Isolation Valve	B-3	RC 200	Closed		
Surge Line Drain to RC Drain Tk Hdr	M-040A B-10	RC 87	Closed		
Pressurizer Vent to Ctmt Vent Hdr Outlet Iso	M-040A, J-3	RC 82	Open		

¹Indicating light IL285 will light when RC 262 is fully open.

Sheet No. 2
of 3

VALVE VERIFICATION LIST A

Enclosure 6
Pressurizer (Normal Operation)

Verification List Only - Consult Shift Supervisor Prior to Repositioning Valve

M-030

VALVE DESCRIPTION	P&ID No. Coord.	VALVE NUMBER	VALVE POSITION	VERIFY BY	IND. VER. BY
Pressurizer Level Instrumentation Source	D-5	RC 14A	Open		
Pressurizer Level Instrumentation Source	D-5	RC 14B	Open		
Pressurizer Level Transmitter LT-RC14-2	D-5		In Service		
Pressurizer Level Instrumentation Source	C-5	RC 14C	Open		
Pressurizer Level Instrumentation Source	C-5	RC 14D	Open		
Pressurizer Level Transmitter LT-RC14-3	C-5		In Service		
Pressurizer Level Instrumentation Source	C-5	RC 14E	Open		
Pressurizer Level Instrumentation Source	C-5	RC 14F	Open		
Pressurizer Level Transmitter LT-RC14-1	C-5		In Service		
Press Vapor Space Pressure Transmitter PT-412	C-5		In Service		
N ₂ Supply to PRZR Vent Iso Valve	C-3	NN 64	Closed		
PZR Vent Line Drain Vlv to CTMT Vent Hdr	A-3	RC 148	Closed		
PZR Vent Line to Quench Tank Isolation	A-3	RC 146*	Locked Open		
PZR Vent Line Vent Vlv to CTMT Vent Hdr	A-3	RC 145	Closed		
PZR Vent Line Throttle Vlv	A-3	RC 147*	Locked Open		
PZR Vent Line to CTMT Vent Hdr Inlet Isolation	A-3	RC 198	Closed		
PZR Sample Line Manual Isolation Valve	B-3	RC 170*	Locked Open		
PZR Sample Line Manual Isolation Valve	B-3	RC 170A*	Locked Open		
RCS Cold Leg Sample Inlet Isolation Valve	D-3	RC 260	Open		
RCS Cold Leg 2-1 Drain Isolation	G-3	RC 32	Open		

*Controlled per AD 1839.02.

Sheet No. 3
of 3

VALVE VERIFICATION LIST A

Enclosure 6
Pressurizer (Normal Operation)

Verification List Only - Consult Shift Supervisor Prior to Repositioning Valve

M-030

VALVE DESCRIPTION	P&ID No. Coord.	VALVE NUMBER	VALVE POSITION	VERIFY BY	IND. VER. BY
RCS Cold Leg Sample Valve	C-3	RC 4632	Closed		
PRZR vent line inlet to R04614	A-3	RC 5007*	Locked Open		
PRZR vent line bypass to R04614	A-3	RC 5006	Closed		

*Controlled per AD 1839.02

Reviewed by _____ Date _____
(Shift Supervisor or Assistant Shift Supervisor)

PRESSURIZER SETPOINT
DIAGRAMPRESSURE SETPOINTS
AS READ ON PRS RC2A1

(PSIG)

LEVEL SETPOINTS
AS READ ON LRS RC14

(INCHES)

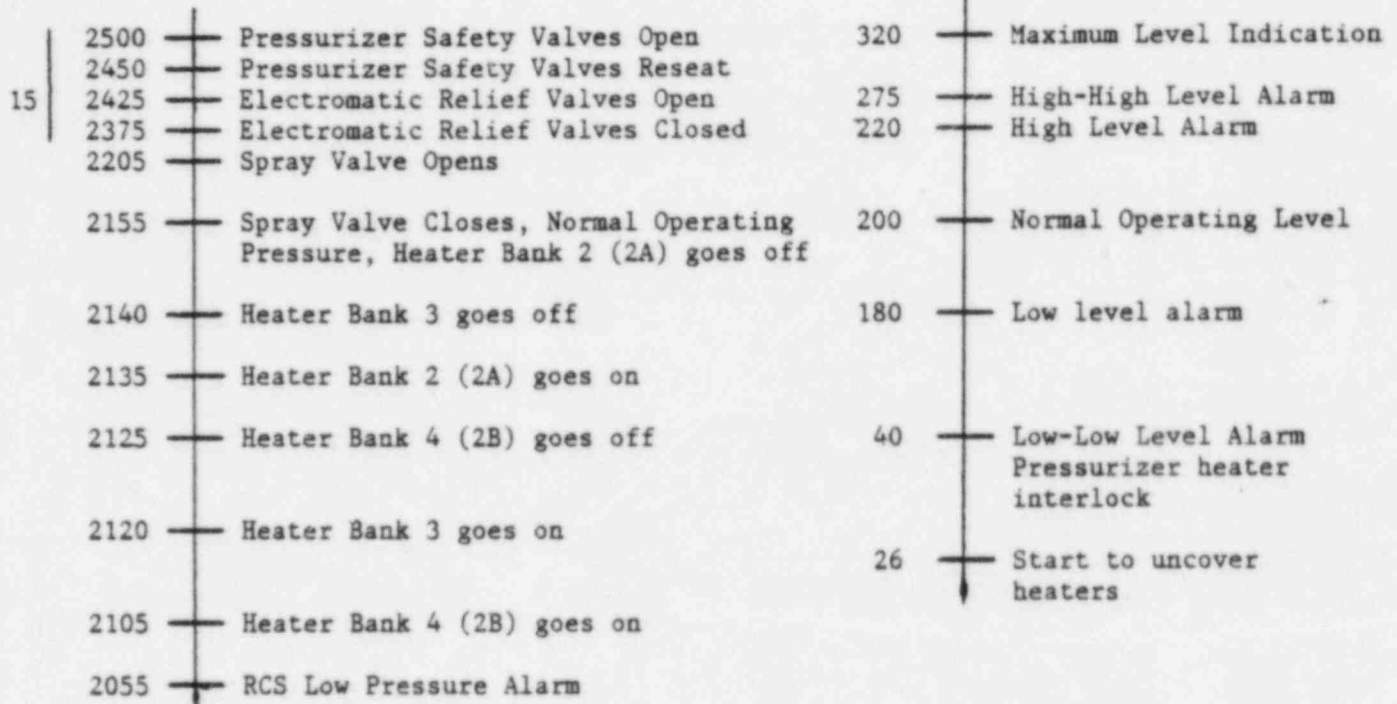

PRESSURIZER HEATER/DH11 AND DH12 INTERLOCK

SFAS CHANNEL 1

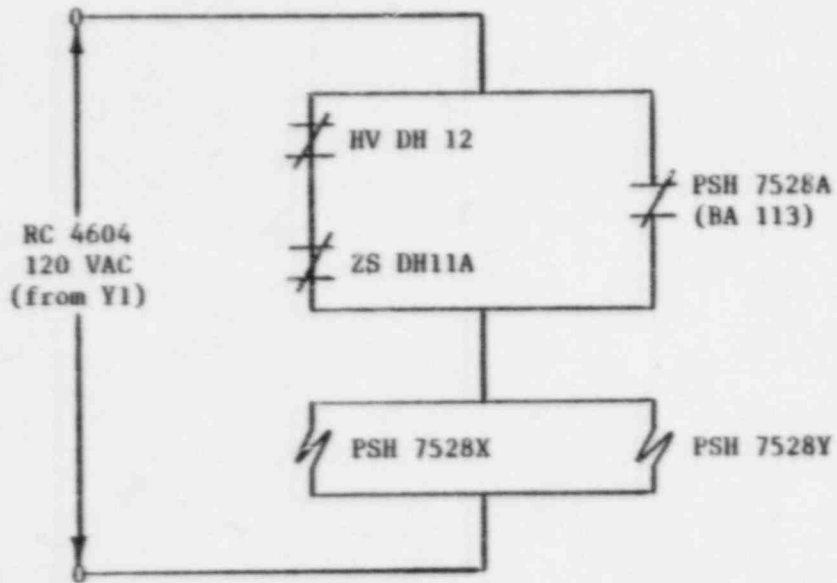

SFAS CHANNEL 4

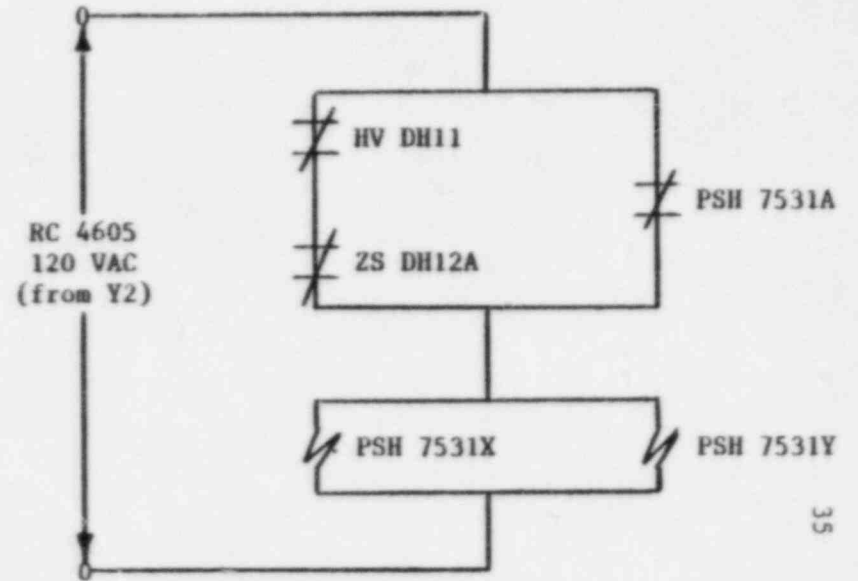

OUTPUT RELAY	PRESSURIZER HEATERS
PSH 7528X	HIS RC2A (essential)
PSH 7528Y	HIS RC2-2
	HIS RC2-3

OUTPUT RELAY	PRESSURIZER HEATERS
PSH 7531X	HIS RC2B (essential)
PSH 7531Y	HIS RC2-4
	PIC RC-2

- NOTE:
- (1) When PSH 7528X, PSH 7528Y, PSH 7531X, PSH 7531Y are energized, the respective heaters are permitted to be energized.
 - (2) HVDH11, HVDH12, ZSDH11A and ZSDH12A are all shown with DH11 closed and DH12 closed.
 - (3) PSH7528A, PSH7531A are shown with RCS pressure less than 301 psig.

DAVIS-BESSE UNIT #1

COMPENSATED
PRESSURIZER LEVEL
REFERENCE LEG AT 62°F
LT-RC 14-1, 2 & 3

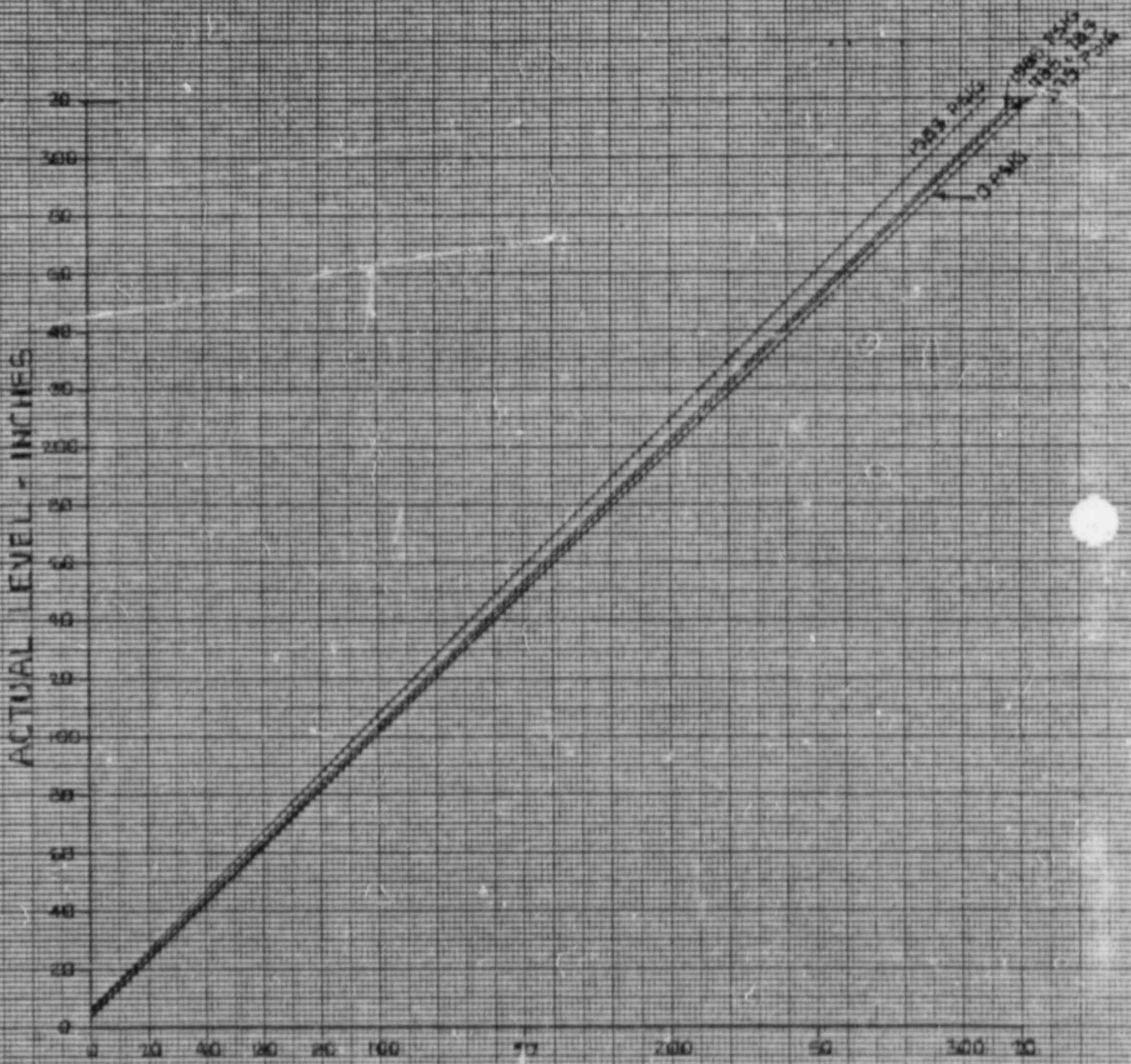

CONTROL RM. COMPENSATED LEVEL RECORDER - INCHES

LRS - RC 14

DAVIS-BESSE UNIT N°1

COMPENSATED PRESSURIZER LEVEL

REFERENCE LEG AT 120°F
LT-RE 14-1, 2 & 3

ACTUAL LEVEL - INCHES

0 20 40 60 80 100 50 200 50 300

CONTROM RM. COMPENSATED LEVEL RECORDER - INCHES

LRS - RC 14

1180 PSIG
1175 PSIG
1170 PSIG

DAVIS-BESSE UNIT N01

COMPENSATED PRESSURIZER LEVEL

REFERENCE LEG AT 150° F
LY-RE 14-1, 2 OR 3

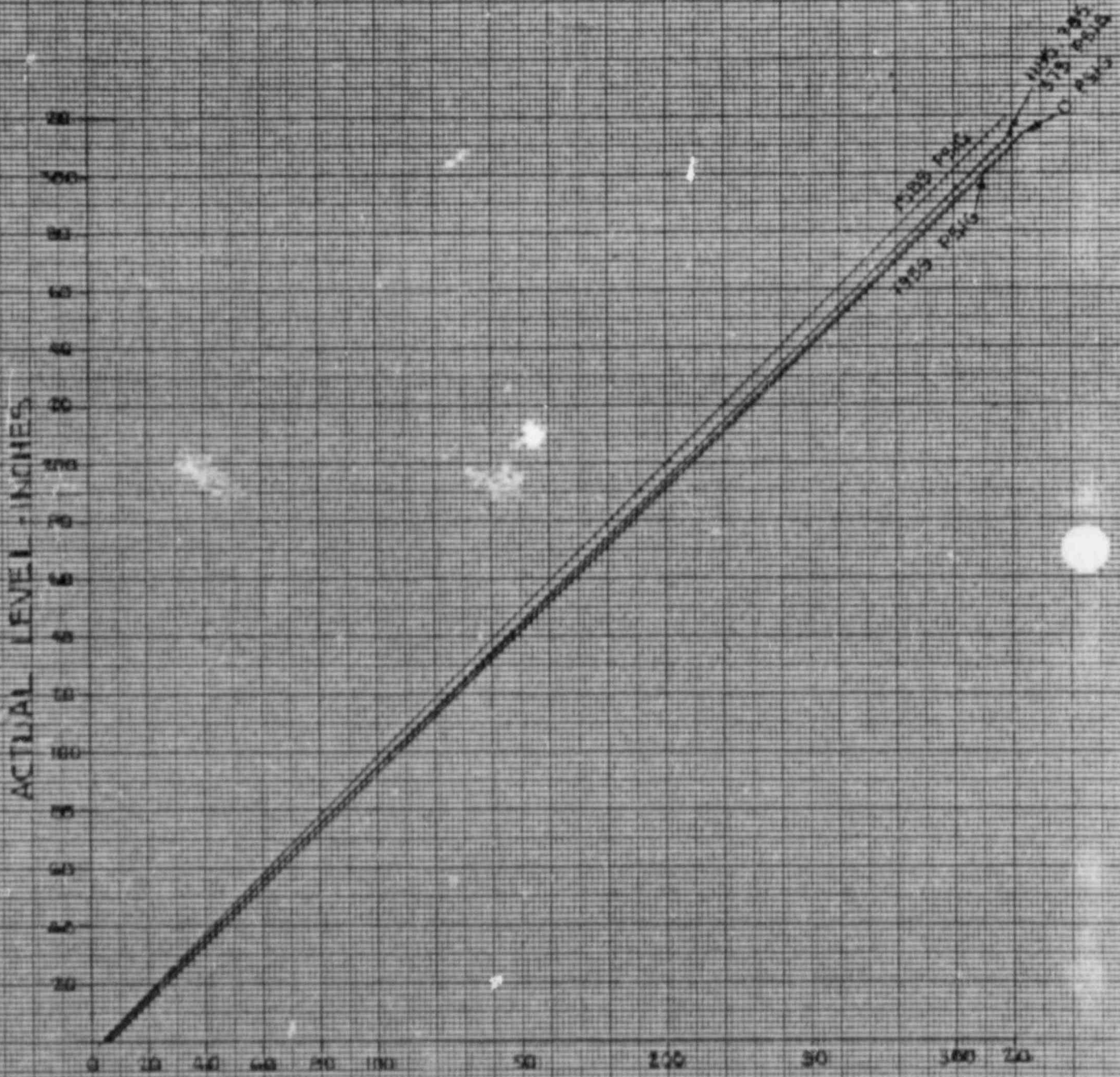

CONTROL RM. COMPENSATED LEVEL RECORDER - INCHES

LRS - RC 14

DAVIS-BESSE UNIT N°1

COMPENSATED PRESSURIZER LEVEL

REFERENCE LEG: A1 2.100" F
LT-RC 14-1, 2 OR 3

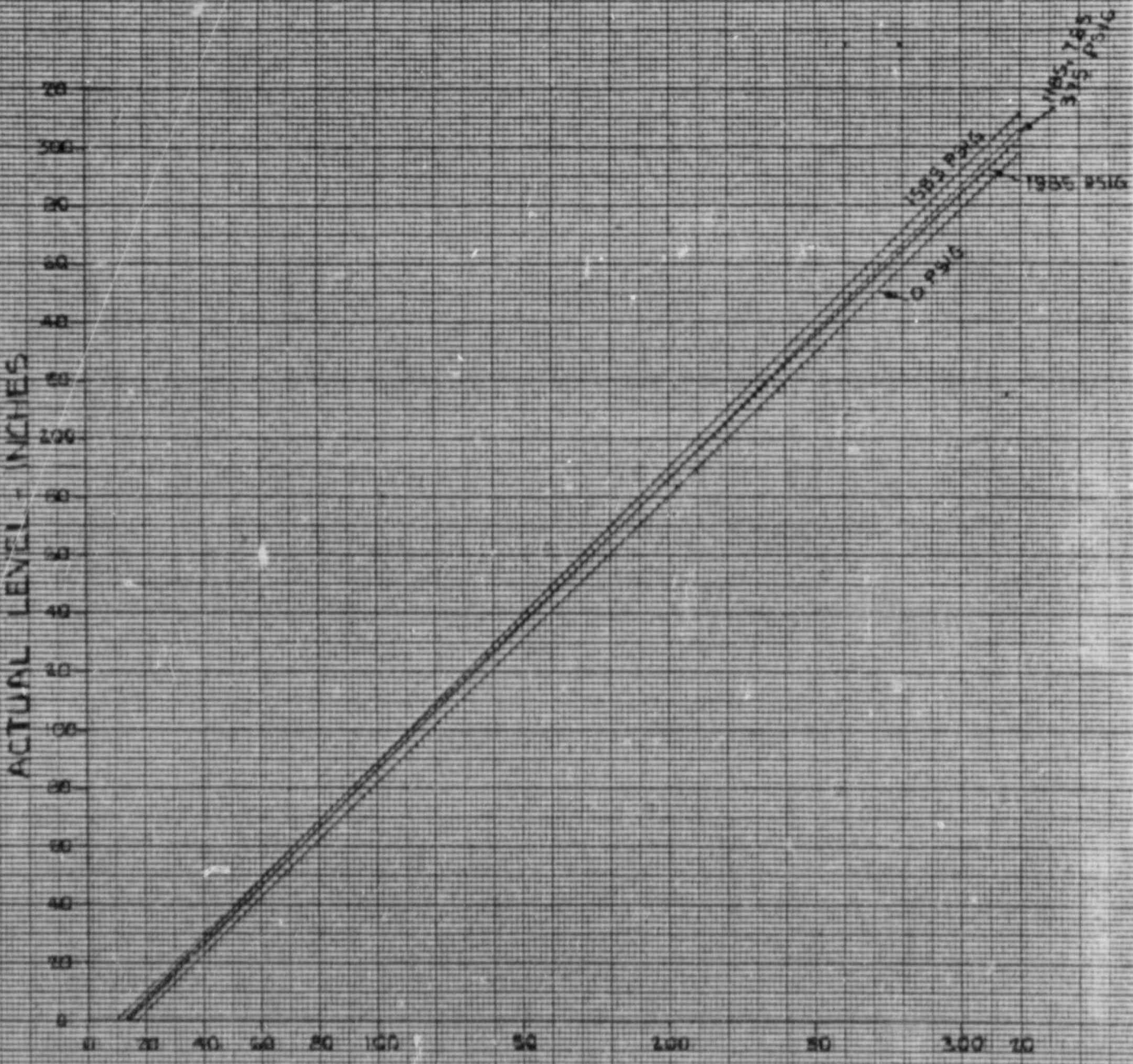

CONTROL RM COMPENSATED LEVEL RECORDER - INCHES

LRS-PC 14

DAVIS-BESSE UNIT N^o 1

COMPENSATED PRESSURIZER LEVEL

REFERENCE LEG AT 250° F
LT - RC 14-1, 2, OR 3

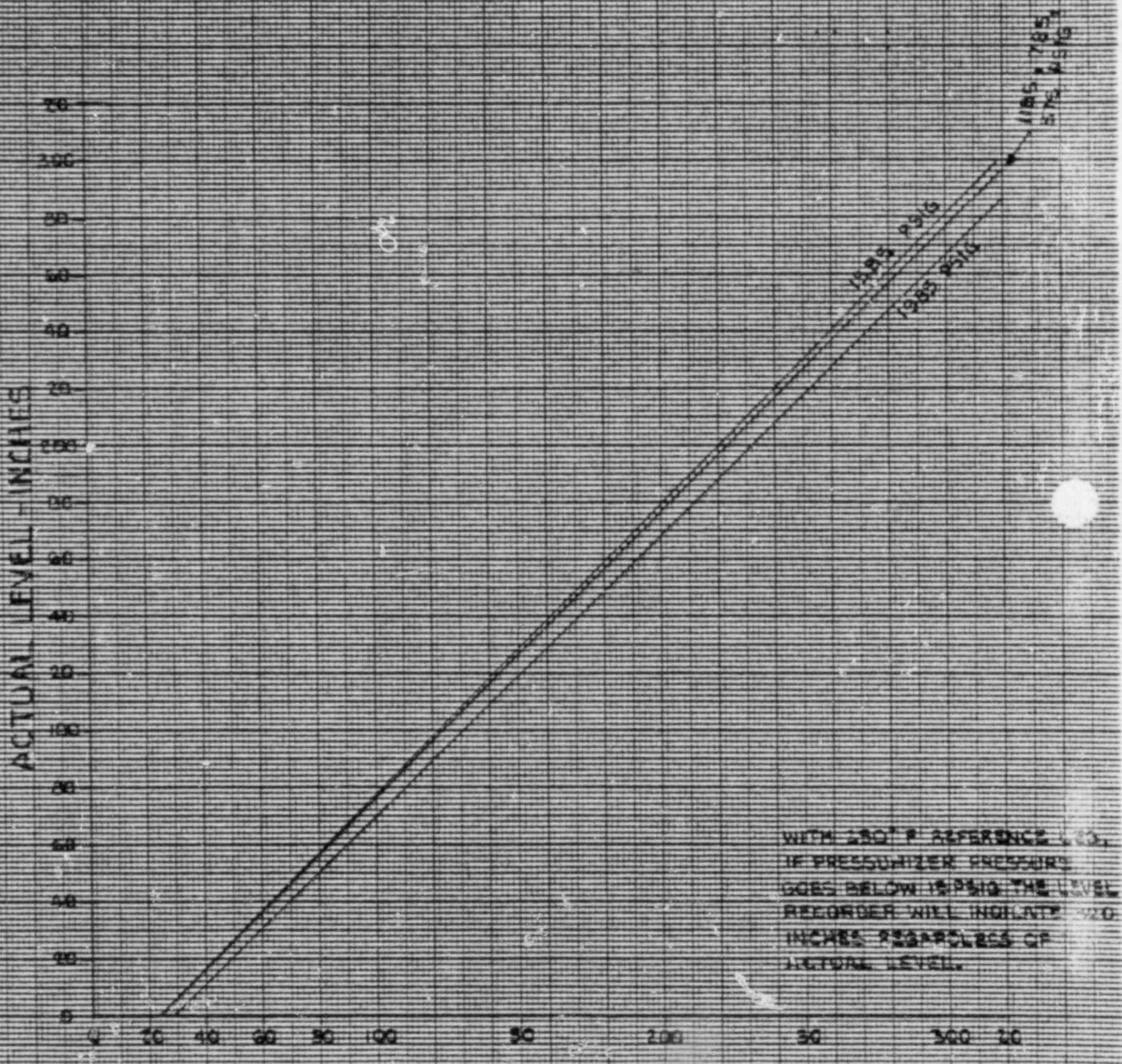

WITH 250° F REFERENCE LEG,
IF PRESSURIZER PRESSURE
GOES BELOW 15 PSIG THE LEVEL
RECORDER WILL INDICATE 20
INCHES REGARDLESS OF
ACTUAL LEVEL.

CONTROL RM. COMPENSATED LEVEL RECORDER - INCHES

LRS - RC 14

DAVIS-BESSE UNIT NRI

UNCOMPENSATED PRESSURIZER LEVEL

REFERENCE LGS AT 250 PSIG
LT-RC 14-1 & 3

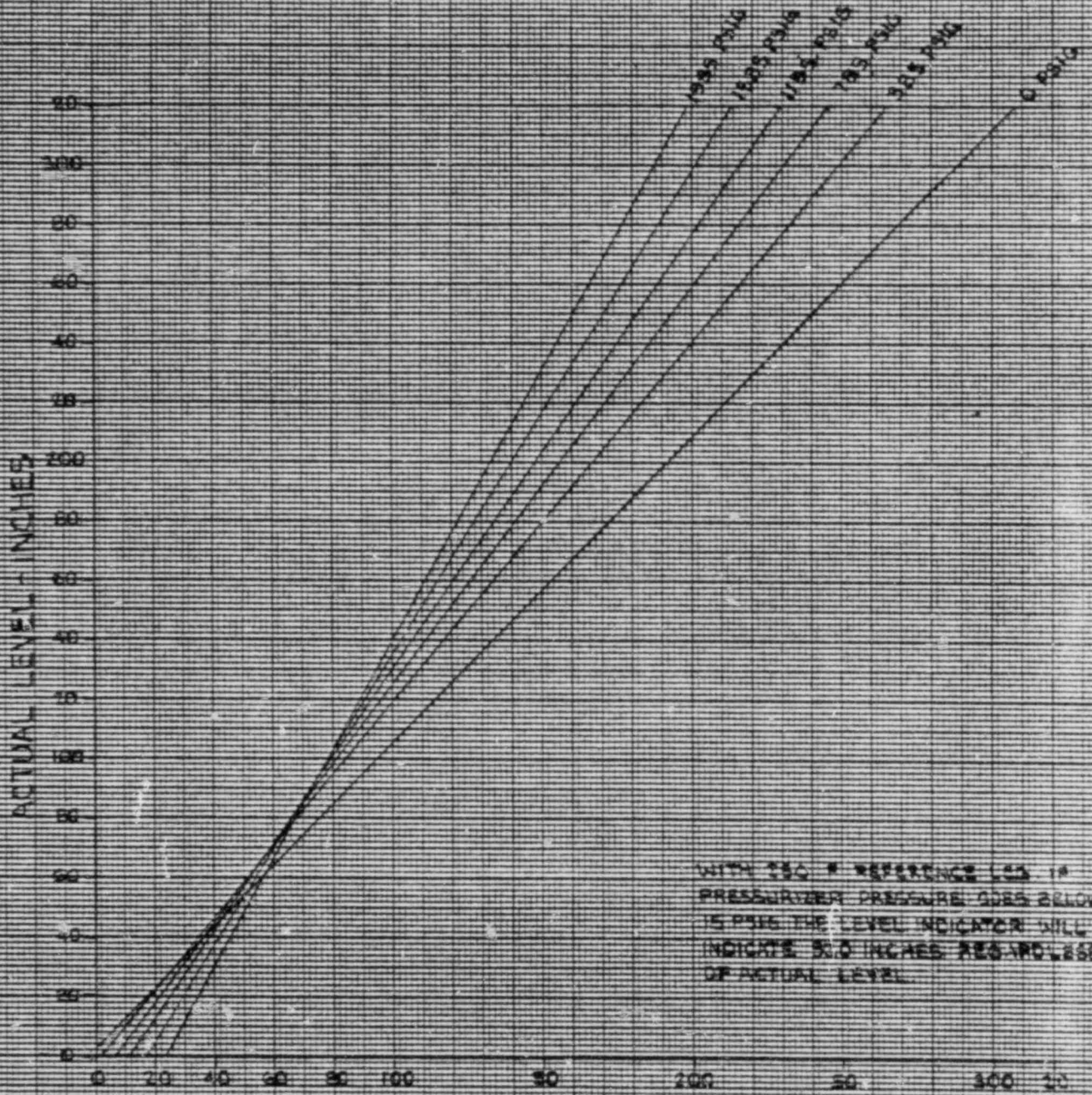

WITH 250 PSIG REFERENCE LGS IF PRESSURIZER PRESSURE GOES BELOW 15 PSIG THE LEVEL INDICATOR WILL INDICATE 50.0 INCHES REGARDLESS OF ACTUAL LEVEL

UNCOMPENSATED LEVEL INDICATOR - INCHES

CONTROL ROOM LI RC 14-3 & 4

AUX. SHUTDOWN PNL LI RC 14-1 & 2

DAVIS BESSE UNIT #1

UNCOMPENSATED PRESSURIZER LEVEL

REFERENCE LEG AT 120°F
LI-RC 14-1 #3

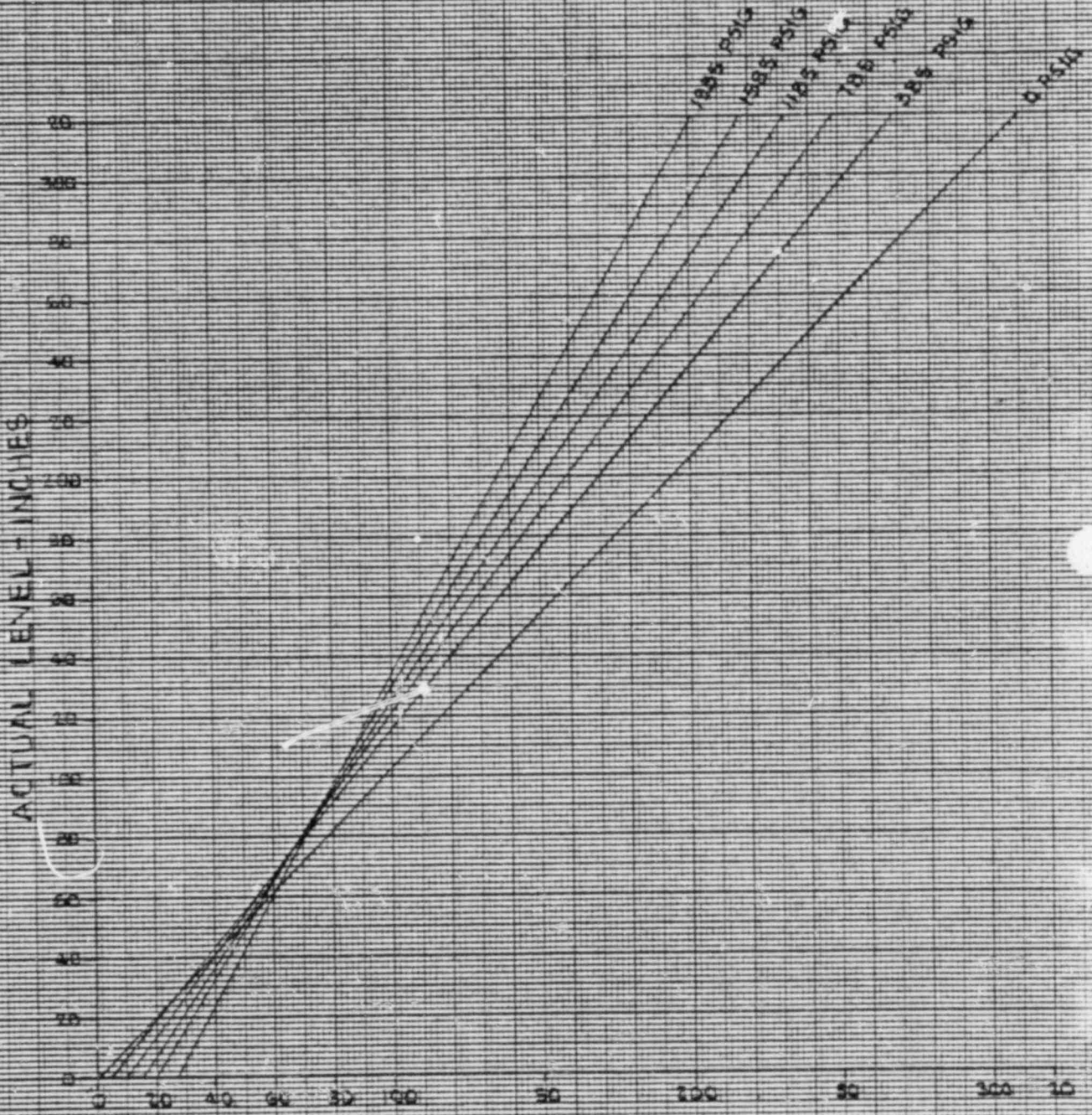

UNCOMPENSATED LEVEL INDICATOR-INCHES

CONTROL ROOM LI RC 14-3 #4

AUX. SHUTDOWN PNL. LI RC 14-1 #2

DAVIS-BESSE UNIT N° 1

UNCOMPENSATED
PRESSURIZER LEVEL
REFERENCE LEG AT 150°F
LT-RC # 143

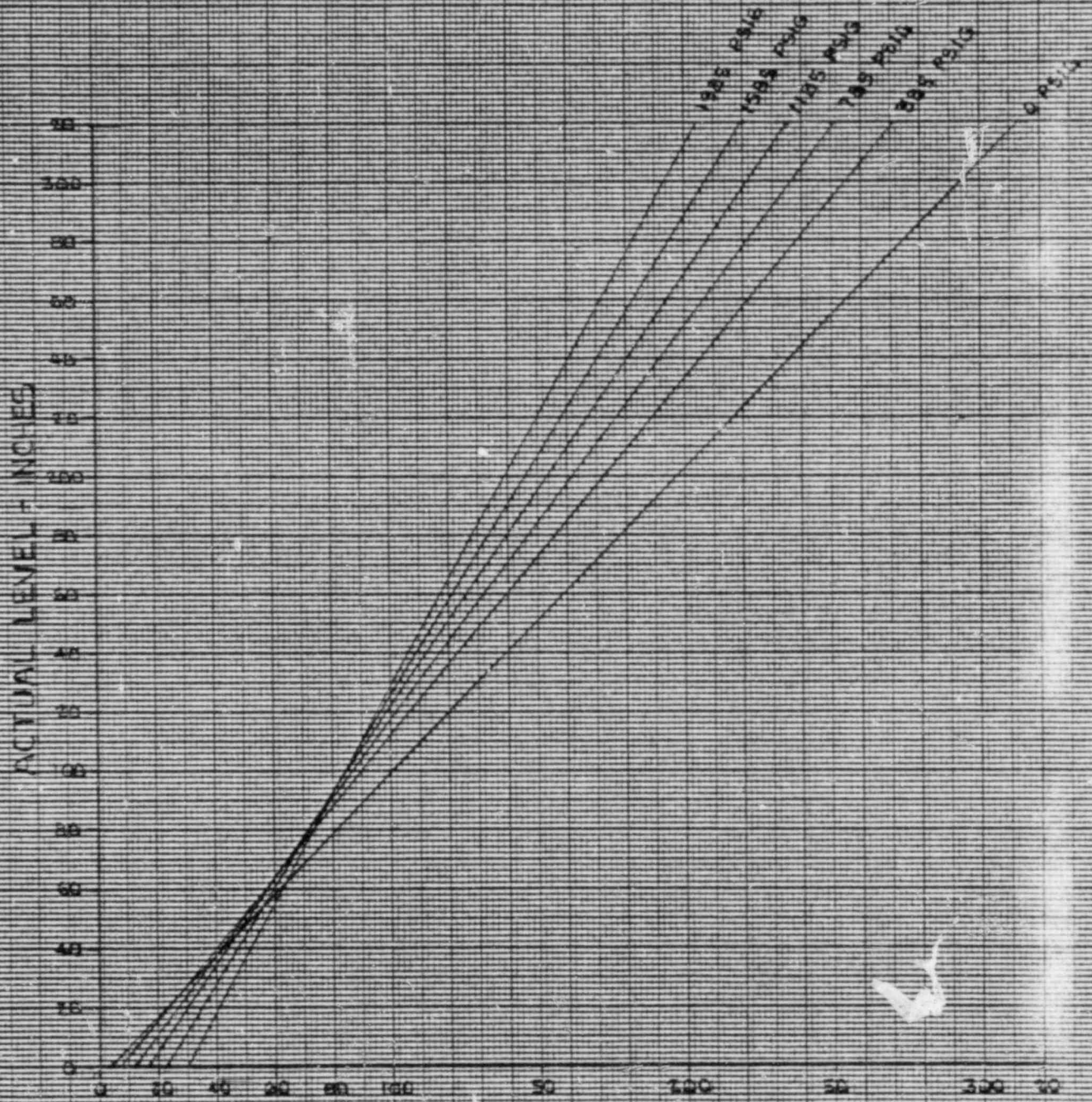

UNCOMPENSATED LEVEL INDICATOR - INCHES
CONTROL ROOM LIRC 14-3-1A
AUX. SHUTDOWN PNL LIRC 14-1-2

DAVIS-BESSE UNIT No. 1

UNCOMPENSATED
PRESTURIZER LEVEL

REFERENCE LEG AT 200° F
LT-RC 14-1 & 2

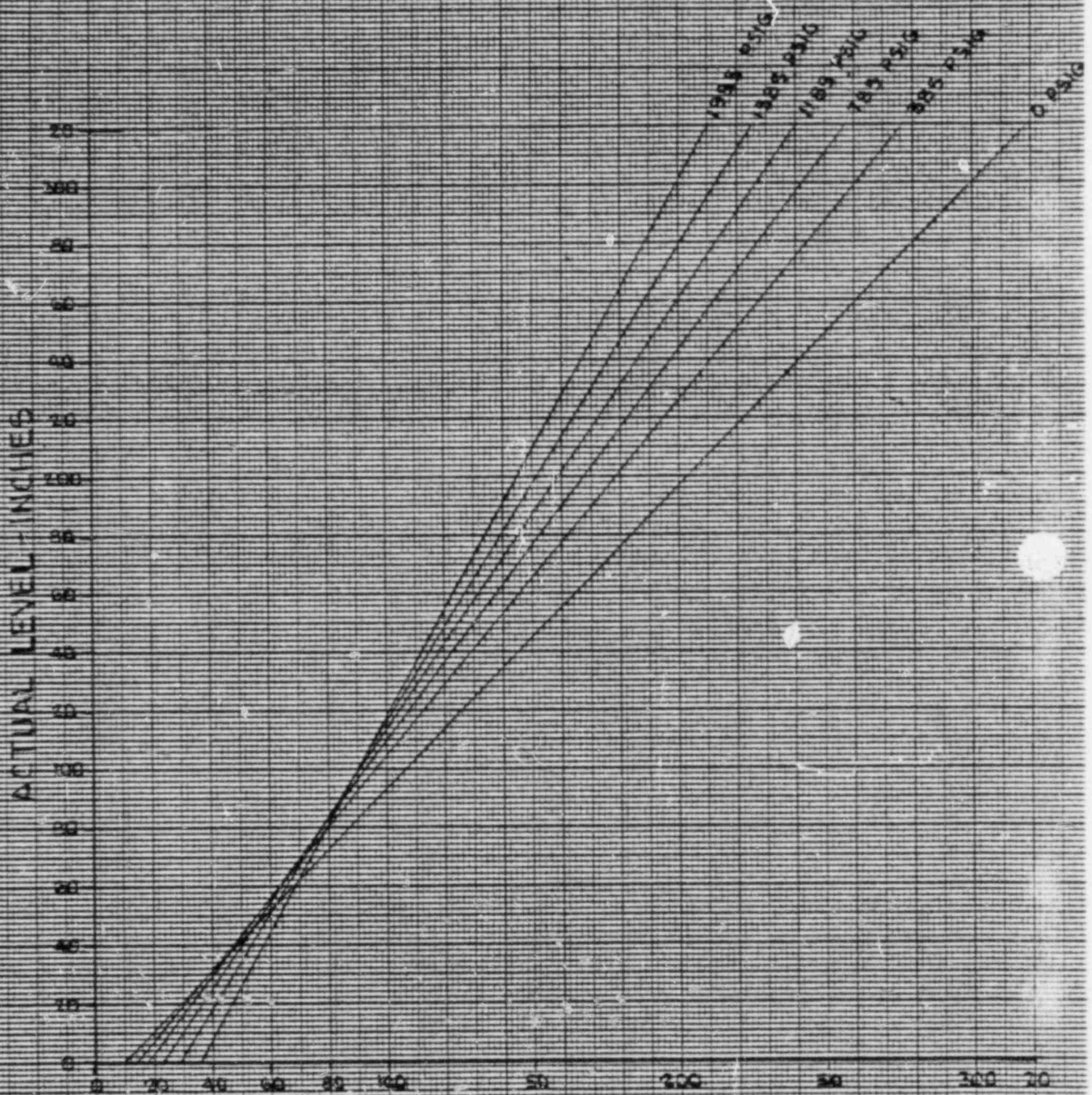

UNCOMPENSATED LEVEL INDICATOR - INCHES

CONTROL ROOM LI RC 14-3 & 4

AUX. SHUTDOWN PNL. RC 14-1 & 2

DAVIS-BESSE UNIT #2

UNCOMPENSATED
PRESSURIZER LEVEL

REFERENCE LEG AT 250° F
LT-RC 14-1 & 3

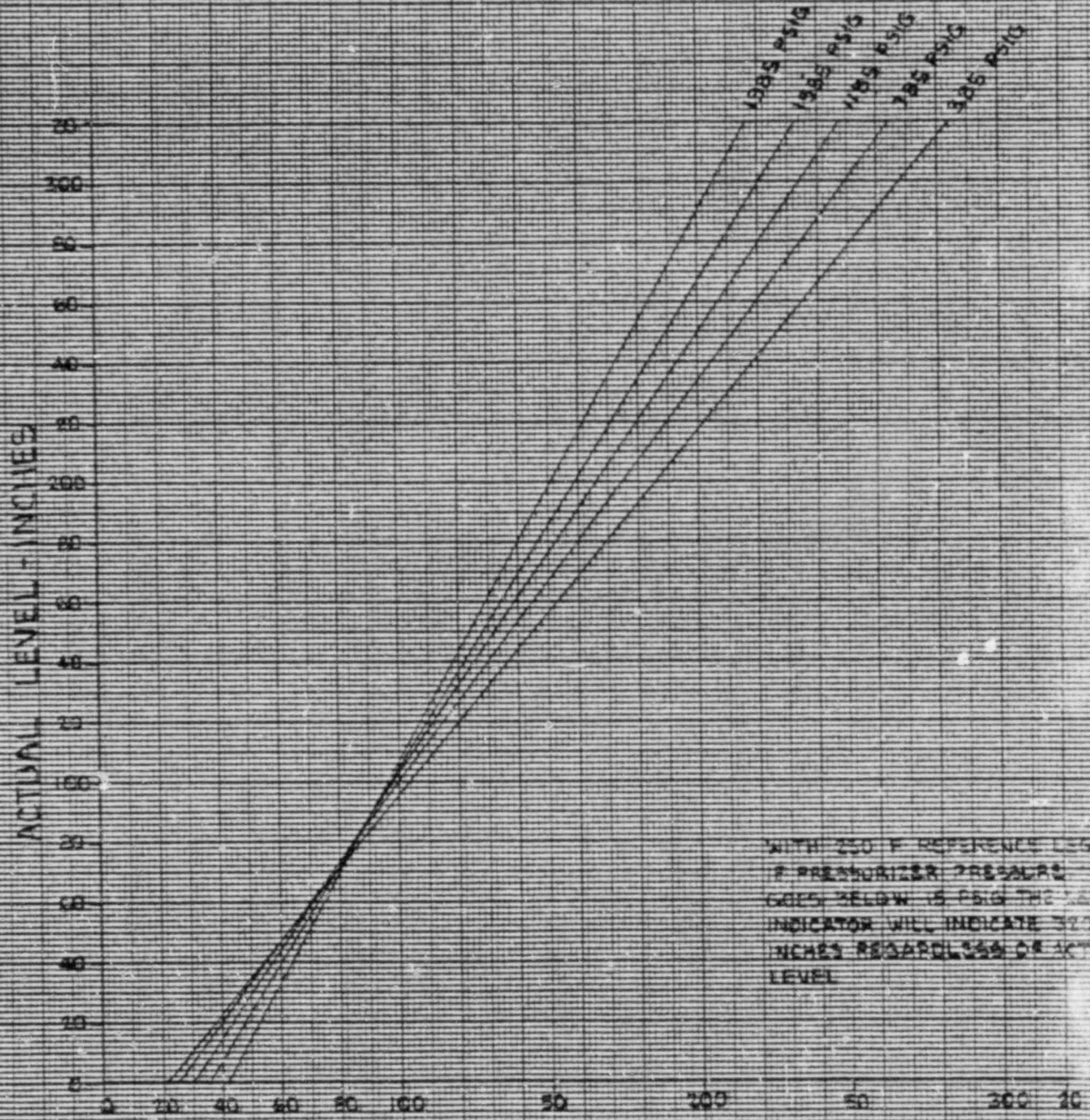

WITH 250 F REFERENCE LEG,
IF PRESSURIZER PRESSURE
GOES BELOW 15 PSIG THE LEVEL
INDICATOR WILL INDICATE 30
INCHES REGARDLESS OF ACTUAL
LEVEL

UNCOMPENSATED LEVEL INDICATOR - INCHES
CONTROL ROOM LI RC 14-3 & 4
AUX SHUTDOWN PNL LI RC 14-1 & 2

END

ATTACHMENT 10
Page 1 of 1

T.E.C² SK.N^o 130C
SH. 3 OF 5

