

INSERVICE INSPECTION AND TESTING PROGRAM

QUAD CITIES NUCLEAR POWER STATION

UNITS 1 AND 2

COMMONWEALTH EDISON COMPANY

OCTOBER 1984

8501160348 850109
PDR ADOCK 05000254
g PDR

TABLE OF CONTENTS

	<u>PAGE</u>
1.0 INTRODUCTION	
1.1 GENERAL INFORMATION.....	1-1
1.2 SYSTEM CLASSIFICATIONS.....	1-1
2.0 INSERVICE INSPECTION PROGRAM	
2.1 DESCRIPTION OF ISI PROGRAM.....	2-1
2.2 PROGRAM TABLES.....	2-7
A. QUAD CITIES UNIT-1	
B. QUAD CITIES UNIT-2	
2.3 RELIEF REQUESTS.....	2-8
3.0 INSERVICE TESTING PROGRAM FOR SNUBBERS	
3.1 DESCRIPTION OF SNUBBER IST PROGRAM.....	3-1
3.2 PROGRAM TABLES.....	3-3
A. QUAD CITIES UNIT-1	
B. QUAD CITIES UNIT-2	
3.3 RELIEF REQUESTS.....	3-6
4.0 INSERVICE TESTING PROGRAM FOR PUMPS	
4.1 DESCRIPTION OF IST PROGRAM FOR PUMPS.....	4-1
4.2 PROGRAM TABLES.....	4-2
A. QUAD CITIES UNIT-1	
B. QUAD CITIES UNIT-2	
4.3 RELIEF REQUESTS.....	4-5

TABLE OF CONTENTS - continued

	<u>PAGE</u>
5.0 INSERVICE TESTING PROGRAM FOR VALVES	
5.1 DESCRIPTION OF IST PROGRAM FOR VALVES.....	5-1
5.2 PROGRAM TABLES.....	5-11
A. QUAD CITIES UNIT-1	
B. QUAD CITIES UNIT-2	
5.3 RELIEF REQUESTS.....	5-13
5.4 COLD SHUTDOWN JUSTIFICATION FOR IST VALVE PROGRAM.....	5-41

1.0 INTRODUCTION

1.1 GENERAL INFORMATION

The Inservice Inspection (ISI) and Inservice Testing (IST) Programs for Quad Cities Nuclear Power Station, Units 1 and 2 are developed in compliance with the rules and regulations of 10CFR50.55a and Section XI of the ASME Boiler and Pressure Vessel Code, 1980 Edition including the Addenda through Winter 1980. Where these rules are determined to be impractical, specific relief is requested in writing.

The Inservice Inspection and Testing Programs for Class 1, 2 and 3 Components, Component Supports, Pumps, & Valves are applicable for the ten year interval beginning February 18, 1983 and March 10, 1983 for Quad Cities Units 1 and 2, respectively. The upcoming ten year interval is the second inspection interval for both Quad Cities Units 1 and 2.

1.2 SYSTEM CLASSIFICATION

The construction permits for Quad Cities Units 1 and 2 were issued on February 15, 1967. At that time the ASME Boiler and Pressure Vessel Code covered only nuclear

vessels. Piping, pumps, and valves were built primarily to the rules of USAS B31.1.0, therefore, the station has essentially no ASME Code Class 1, 2 or 3 designed systems. The system classifications used as a basis for the Inservice Inspection and Testing Programs are based on the requirements set forth in 10CFR50 and Regulatory Guide 1.26 and were developed for the sole purpose of assigning the appropriate inservice inspection requirements. Components within the primary coolant pressure boundary, as defined in 10CFR50.2(v), are designated as ISI-Class 1 while other safety related components are designated as ISI-Class 2 and 3 in accordance with the guidelines of Regulatory Guide 1.26. Pursuant to 10CFR50 paragraph (g)(1), inservice inspection requirements of Section XI of the ASME Code are then assigned to these components, within the constraints of existing plant design.

Class Code Flagged Piping and Instrument Diagrams (P&IDs) documenting the system classifications were developed to aid in the review and implementation of the subject programs. A legend explaining the class code flagging scheme is included on the first page of the P&IDs.

2.0 INSERVICE INSPECTION PROGRAM FOR COMPONENTS

2.1 PROGRAM DESCRIPTION

2.1.1 The Inservice Inspection Program for ISI Class 1, 2 and 3 components meets the requirements of Section XI of the ASME Boiler and Pressure Vessel Code, 1980 Edition through the Winter 1980 Addenda. Where these requirements are determined to be impractical, specific requests for relief have been written and included in Section 2.3.

2.1.2 The ISI Component Program is presented in Section 2.2 in a tabular format. The components and associated requirements are listed according to ascending Code Category and Item Numbers. The following information is included in the tables:

- A. Code Category - The Section XI Examination Categories as defined in Table IWB-2500-1, IWC-2500-1, IWD-2500-1, and IWF-2500-1 for Class 1, 2, and 3 components.

- B. Item Number and Item Description - The Item Number and its description as listed in Tables IWB, IWC, IWD-2500-1, and IWF-2500-2. Applicable Item

numbers and all Item Descriptions are listed for each Code Category.

- C. Section XI Exam Required lists the examination method or methods. This reflects the Section XI requirements. The abbreviations used are as follows:

VOL - Volumetric per IWA-2230

SUR - Surface per IWA-2220

VT-1 - Visual per IWA-2211

VT-2 - Visual per IWA-2212

VT-3 - Visual per IWA-2213

VT-4 - Visual per IWA-2214

- D. Relief Requests references either a specific relief request contained in Section 2.3 or references one of the Code allowed exemptions listed below. If the latter is referenced, the particular line or component has been exempted from volumetric and/or surface examination by the applicable Code paragraph. Components exempted from examination by Code allowed exemptions will not appear in the component tables of this program in most cases. It should be noted that section 2.3 contains some generic relief requests that are not specifically

referenced in the tables but apply to the ISI Program in general.

- EX-1 - IWB-1220(b), lines 1-inch nominal pipe size (n.p.s.) and less.
- EX-2 - IWB-1220(a), liquid carrying lines 2-inch n.p.s. and less (see 2.1.3)
- EX-3 - IWB-1220(a), steam carrying lines 4-inch n.p.s. and less (see 2.1.3)
- EX-4 - IWB-1220(c), head connections, 2-inches n.p.s. and less, made inaccessible by CRD penetrations
- EX-5 - IWC-1220(b), components not required to operate above a temperature of 200°F or above a pressure of 275 psig.
- EX-6 - IWC-1220(c), component connections, piping and associated valves, and vessels and their attachments that are \leq 4 in. n.p.s.
- EX-7 - IWC-1220(a), lines not required during normal operating conditions but remain flooded under static conditions at a minimum of 80% of the pressure they would be subjected to when required to operate.
- EX-8 - IWC-1230, piping support members and piping support components encased in concrete.

EX-9 - IWD-1220.1, integral attachments of supports and restraints to components that are 4 in. n.p.s. and smaller.

EX-10 - IWD-1220.2(a), integral attachments of supports and restraints in systems whose function is not required in support of reactor residual heat removal and emergency core cooling.

EX-11 - IWD-1220.2(b), integral attachments of supports and restraints where operating pressure is 275 psig or less and operating temperature is 200°F or less.

EX-12 - IWD-5223(e), open ended vent and drain lines from components extending beyond the last shut-off valve and open ended safety or relief valve discharge lines.

E. Alternate Exam lists the examination method or methods that will be performed in lieu of the required Section XI methods when relief has been requested.

F. Remarks - lists general clarification remarks.

2.1.3 Pursuant to paragraph IWB-1220(a), the maximum size line break that can be made up by the reactor coolant makeup

system has been calculated to be 2.08 inches inside diameter for liquid carrying lines and 4.16 inches for steam carrying lines. In applying this exemption to the program, liquid carrying lines less than or equal to 2 inch nominal pipe size and steam carrying lines less than or equal to 4.0 inches n.p.s. were exempted.

2.1.4 Table 2.1-1 lists the applicable Class 1, 2 & 3 systems which are covered in the Inservice Inspection Program.

TABLE 2.1-1

LIST OF SYSTEMS INCLUDED IN THE ISI PROGRAM

SYSTEM	CLASS
Control Rod Drive	1 & 2
Residual Heat Removal (RHR)	1 & 2
RHR Service Water	3
Standby Liquid Control (SBLC)	1 & 2
Reactor Water Cleanup	1
Core Spray	1 & 2
High Pressure Coolant Injection (HPCI)	1 & 2
Main Steam	1
Feedwater	1 & 2
Diesel Generator Cooling Water	3

SECTION 2.2

TABLES FOR INSERVICE INSPECTION PROGRAM

A. QUAD CITIES UNIT-1

B. QUAD CITIES UNIT-2



Commonwealth
Edison

INSERVICE INSPECTION PROGRAM

ISI - CLASS 1,2&3 COMPONENTS
QUAD CITIES NUCLEAR POWER STATION

UNIT - 1

CLASS 1

Page 1 of 15
Revision 2 Date 9-17-84

CODE CATEGORY	ITEM NUMBER	ITEM DESCRIPTION	SECT XI EXAM REQUIRED	RELIEF REQUESTS	ALTERNATE EXAM	REMARKS
B.A		PRESSURE RETAINING WELDS IN REACTOR VESSEL				
	01.10	Shell Welds				
	01.11	Circumferential	VOL	CR-1		
	01.12	Longitudinal	VOL	CR-1		
	01.20	Head Welds				
	01.21	Circumferential	VOL	CR-2		
	01.22	Meridional	VOL	CR-2		
	01.30	Shell-to-Flange Weld	VOL			
	01.40	Head-to-Flange Weld	VOL AND SURF			
	01.50	Repair Welds				N/A
B.B		PRESSURE RETAINING WELDS IN VESSELS OTHER THAN REACTOR VESSELS				N/A
B.D		FULL PENETRATION WELDS OF NOZZLES IN VESSELS - INSPECTION PROGRAM B				
		Reactor Vessel				
	01.90	Nozzle-to-Vessel Welds	VOL			
	01.100	Nozzle Inside Radius Section	VOL			



Commonwealth
Edison

INSERVICE INSPECTION PROGRAM

ISI - CLASS 1,2&3 COMPONENTS
QUAD CITIES NUCLEAR POWER STATION

UNIT - 1

CLASS 1

Page 2 of 15
Revision 2 Date 9-17-84

CODE CATEGORY	ITEM NUMBER	ITEM DESCRIPTION	SECT XI EXAM REQUIRED	RELIEF REQUESTS	ALTERNATE EXAM	REMARKS
		Pressurizer				
	B3.110	Nozzle-to-Vessel Welds				N/A
	B3.120	Nozzle Inside Radius Section				N/A
		Steam Generators (Primary Side)				
	B3.130	Nozzle-to-Vessel Welds				N/A
	B3.140	Nozzle Inside Radius Section				N/A
		Heat Exchangers (Primary Side)				
	B3.150	Nozzle-to-Vessel Welds				N/A
	B3.160	Nozzle Inside Radius Section				N/A
B-E		PRESSURE RETAINING PARTIAL PENETRATION WELDS IN VESSELS				
	B4.10	Partial Penetration Welds				EXTERNAL SURFACES
	B4.11	Vessel Nozzles	VT-2			
	B4.12	Control Rod Drive Nozzles	VT-2			
	B4.11	Instrumentation Nozzles	VT-2			
		Pressurizer				
	B4.20	Heater Penetration Welds				N/A
B-F		PRESSURE RETAINING DISSIMILAR METAL WELDS				
		Reactor Vessel				
	B5.10	Nominal Pipe Size \geq 4 in. Nozzle-to-Safe End Butt Welds	VOL AND SURF			



Commonwealth
Edison

INSERVICE INSPECTION PROGRAM

ISI - CLASS 1,2&3 COMPONENTS
QUAD CITIES NUCLEAR POWER STATION

UNIT - 1

CLASS 1

Page 3 of 15
Revision 2 Date 9-17-84

CODE CATEGORY	ITEM NUMBER	ITEM DESCRIPTION	SECT XI EXAM REQUIRED	RELIEF REQUESTS	ALTERNATE EXAM	REMARKS
	U5.11	Nominal Pipe Size < 4 in. Nozzle-to-Safe End Butt Welds	SURF			N/A
	U5.12	Nozzle-to-Safe End Socket Welds				
		Pressurizer				
	U5.20	Nominal Pipe Size ≥ 4 in. Nozzle-to-Safe End Butt Welds				N/A
	U5.21	Nominal Pipe Size < 4 in. Nozzle-to-Safe End Butt Welds				N/A
	U5.22	Nozzle-to-Safe End Socket Welds				N/A
		Steam Generator				
	U5.30	Nominal Pipe Size ≥ 4 in. Nozzle-to-Safe End Butt Welds				N/A
	U5.31	Nominal Pipe Size < 4 in. Nozzle-to-Safe End Butt Welds				N/A
	U5.32	Nozzle-to-Safe End Socket Welds				N/A
		Heat Exchangers				
	U5.40	Nominal Pipe Size ≥ 4 in. Nozzle-to-Safe End Butt Welds				N/A
	U5.41	Nominal Pipe Size < 4 in. Nozzle-to-Safe End Butt Welds				N/A
	U5.42	Nozzle-to-Safe End Socket Welds				N/A
		Piping				
	U5.50	Nominal Pipe Size ≥ 4 in. Dissimilar Metal Butt Welds	VOL AND SURF			SEE FIG. IWB-2500-B



Commonwealth
Edison

INSERVICE INSPECTION PROGRAM

ISI - CLASS 1,2&3 COMPONENTS
QUAD CITIES NUCLEAR POWER STATION

UNIT - 1

CLASS 1

Page 4 of 15

Revision 2 Date 9-17-84

CODE CATEGORY	ITEM NUMBER	ITEM DESCRIPTION	SECT XI EXAM REQUIRED	RELIEF REQUESTS	ALTERNATE EXAM	REMARKS	
B-G-1	B5.51	Nominal Pipe Size < 4 in. Dissimilar Metal Butt Welds	SURF			N/A	
	B5.52	Dissimilar Metal Socket Welds					
		PRESSURE RETAINING BOLTING, GREATER THAN 2 in. IN DIAMETER					
		Reactor Vessel					
	B6.10	Closure Head Nuts	SURF				
	B6.20	Closure Studs, in place	VOL				
	B6.30	Closure Studs, when removed	SURF AND VOL				
	B6.40	Threads in Flange	VOL				
	B6.50	Closure Washers, Bushings	VT-1				
		Pressurizer					
	B6.60	Bolts and Studs					N/A
	B6.70	Flange Surface, when connection disassembled					N/A
B6.80	Nuts, Bushings, and Washers		N/A				
	Steam Generators						
B6.90	Bolts and Studs		N/A				
B6.100	Flange Surface, when connection disassembled		N/A				
B6.110	Nuts, Bushings, and Washers		N/A				
	Heat Exchangers						
B6.120	Bolts and Studs		N/A				



Commonwealth
Edison

INSERVICE INSPECTION PROGRAM

ISI - CLASS 1,2&3 COMPONENTS
QUAD CITIES NUCLEAR POWER STATION

UNIT - 1

CLASS 1

Page 5 of 15

Revision 2

Date 9-17-84

CODE CATEGORY	ITEM NUMBER	ITEM DESCRIPTION	SECT XI EXAM REQUIRED	RELIEF REQUESTS	ALTERNATE EXAM	REMARKS
	B6.130	Flange Surface, when connection disassembled				N/A
	B6.140	Nuts, Bushings, and Washers				N/A
		Piping				
	B6.150	Bolts and Studs				N/A
	B6.160	Flange Surface, when connection disassembled				N/A
	B6.170	Nuts, Bushings, and Washers				N/A
		Pumps				
	B6.180	Bolts and Studs	VOL			
	B6.190	Flange Surface, when connection disassembled	VT-1			
	B6.200	Nuts, Bushings, and Washers	VT-1			
		Valves				
	B6.210	Bolts and Studs				N/A
	B6.220	Flange Surface, when connection disassembled				N/A
	B6.230	Nuts, Bushings, and Washers				N/A
B-G-2		PRESSURE RETAINING BOLTING, 2 in. AND LESS IN DIAMETER				
		Reactor Vessel				
	B7.10	Bolts, Studs, and Nuts				N/A



Commonwealth
Edison

INSERVICE INSPECTION PROGRAM

ISI - CLASS 1,2&3 COMPONENTS
QUAD CITIES NUCLEAR POWER STATION

UNIT - 1

CLASS 1

Page 6 of 15
Revision 2 Date 9-17-84

CODE CATEGORY	ITEM NUMBER	ITEM DESCRIPTION	SECT XI EXAM REQUIRED	RELIEF REQUESTS	ALTERNATE EXAM	REMARKS
	B7.20	Pressurizer Bolts, Studs, and Nuts				N/A
	B7.30	Steam Generators Bolts, Studs, and Nuts				N/A
	B7.40	Heat Exchangers Bolts, Studs, and Nuts				N/A
	B7.50	Piping Bolts, Studs, and Nuts	VT-1			
	B7.60	Pumps Bolts, Studs, and Nuts				N/A
	B7.70	Valves Bolts, Studs, and Nuts	VT-1			
	B7.80	CRD Housings Bolts, Studs, and Nuts	VT-1			WHEN DISASSEMBLED
B-II		INTEGRAL ATTACHMENTS FOR VESSELS				
	B8.10	Reactor Vessel Integrally Welded Attachments	SURF			VESSEL SUPPORT SKIRT; SEE FIG. IWB-2500-11 LIFTING LUGS, STABILIZER LUGS SEE FIG. IWB-2500-15



Commonwealth
Edison

INSERVICE INSPECTION PROGRAM

ISI - CLASS 1,2&3 COMPONENTS
QUAD CITIES NUCLEAR POWER STATION

UNIT - 1

CLASS 1

Page 7 of 15
Revision 2 Date 9-17-84

CODE CATEGORY	ITEM NUMBER	ITEM DESCRIPTION	SECT XI EXAM REQUIRED	RELIEF REQUESTS	ALTERNATE EXAM	REMARKS
	00.20	Pressurizer Integrally Welded Attachments				N/A
	08.30	Steam Generator Integrally Welded Attachments				N/A
	08.40	Heat Exchangers Integrally Welded Attachments				N/A
B-J		PRESSURE RETAINING WELDS IN PIPING				
	09.10	Nominal Pipe Size \geq 4 in.				
	09.11	Circumferential Welds	SURF AND VOL	CR-3,CR-4		
	09.12	Longitudinal Welds	SURF AND VOL	CR-4		
	09.20	Nominal Pipe Size < 4 in.				
	09.21	Circumferential Welds	SURF			
	09.22	Longitudinal Welds	SURF			
	09.30	Branch Pipe Connection Welds				
	09.31	Nominal Pipe Size \geq 4 in.	SURF AND VOL	CR-5	VT-2	
	09.32	Nominal Pipe Size < 4 in.	SURF			
	09.40	Socket Welds				N/A



Commonwealth
Edison

INSERVICE INSPECTION PROGRAM

ISI - CLASS 1,2&3 COMPONENTS
QUAD CITIES NUCLEAR POWER STATION

UNIT - 1

CLASS 1

Page 8 of 15
Revision 2 Date 9-17-84

CODE CATEGORY	ITEM NUMBER	ITEM DESCRIPTION	SECT XI EXAM REQUIRED	RELIEF REQUESTS	ALTERNATE EXAM	REMARKS
B-K-1		INTEGRAL ATTACHMENTS FOR PIPING, PUMPS AND VALVES				
		Piping				
	B10.10	Integrally Welded Attachments	SURF			SEE FIG. IWB-2500-13,15
		Pumps				
	B10.20	Integrally Welded Attachments	SURF			SEE FIG. IWB-2500-13,15
		Valves				
	B10.30	Integrally Welded Attachments	SURF			SEE FIG. IWB-2500-13,15
B-L-1, B-M-1		PRESSURE RETAINING WELDS IN PUMP CASINGS AND VALVE BODIES				N/A
B-L-2, B-M-2		PUMP CASINGS AND VALVE BODIES				
	B12.20	Pump Casing	VT-3	CR-6		WHEN DISASSEMBLED
	B12.40	Valve Body, Exceeding 4 in. Nominal Pipe Size	VT-3	CR-7		WHEN DISASSEMBLED
B-N-1		INTERIOR OF REACTOR VESSEL				
		Reactor Vessel				
	B11.10	Vessel Interior	VT-3			PER TABLE IWB-2500-1, CATEGORY B-N-1



Commonwealth
Edison

INSERVICE INSPECTION PROGRAM

ISI - CLASS 1,2&3 COMPONENTS
QUAD CITIES NUCLEAR POWER STATION

UNIT - 1

CLASS 1

Page 9 of 15
Revision 2 Date 9-17-84

CODE CATEGORY	ITEM NUMBER	ITEM DESCRIPTION	SECT XI EXAM REQUIRED	RELIEF REQUESTS	ALTERNATE EXAM	REMARKS
	B13.20	Reactor Vessel (DWR) Interior Attachments	VT-1			ACCESSIBLE WELDS ACCESSIBLE SURFACES
	B13.21	Core Support Structure	VT-1			
	B13.30	Reactor Vessel (IWR) Core Support Structure				N/A
B-0		PRESSURE RETAINING WELDS IN CONTROL ROD HOUSINGS				
	B14.10	Reactor Vessel Welds in CRD Housing	VOL	EX-2		EX-2 APPLIED TO THESE HOUSINGS DUE TO CONFIGURATION
B-P		ALL PRESSURE RETAINING COMPONENTS				
	B15.10	Reactor Vessel Pressure Retaining Boundary	VT-2			LEAKAGE TEST
	B15.11	Pressure Retaining Boundary	VT-2			HYDROSTATIC TEST
	B15.20	Pressurizer Pressure Retaining Boundary				N/A
	B15.21	Pressure Retaining Boundary				N/A
	B15.30	Steam Generators Pressure Retaining Boundary				N/A
	B15.31	Pressure Retaining Boundary				N/A



Commonwealth
Edison

INSERVICE INSPECTION PROGRAM

ISI - CLASS 1,2&3 COMPONENTS
QUAD CITIES NUCLEAR POWER STATION

UNIT - 1

CLASS 1

Page 10 of 15

Revision 2

Date 9-17-84

CODE CATEGORY	ITEM NUMBER	ITEM DESCRIPTION	SECT XI EXAM REQUIRED	RELIEF REQUESTS	ALTERNATE EXAM	REMARKS
		Heat Exchangers				
	B15.40	Pressure Retaining Boundary				N/A
	B15.41	Pressure Retaining Boundary				N/A
		Piping				
	B15.50	Pressure Retaining Boundary	VT-2			LEAKAGE TEST
	B15.52	Pressure Retaining Boundary	VT-2			HYDROSTATIC TEST
		Pumps				
	B15.60	Pressure Retaining Boundary	VT-2			LEAKAGE TEST
	B15.61	Pressure Retaining Boundary	VT-2			HYDROSTATIC TEST
		Valves				
	B15.70	Pressure Retaining Boundary	VT-2			LEAKAGE TEST
	B15.71	Pressure Retaining Boundary	VT-2			HYDROSTATIC TEST
B-Q		STEAM GENERATOR TUBING				N/A



Commonwealth
Edison

INSERVICE INSPECTION PROGRAM

ISI - CLASS 1,2&3 COMPONENTS
QUAD CITIES NUCLEAR POWER STATION

UNIT - 1

CLASS 2

Page 11 of 15

Revision 2

Date 9-17-84

CODE CATEGORY	ITEM NUMBER	ITEM DESCRIPTION	SECT XI EXAM REQUIRED	RELIEF REQUESTS	ALTERNATE EXAM	REMARKS
C-A		PRESSURE RETAINING WELDS IN PRESSURE VESSELS				
	C1.10	Shell Circumferential Welds	VOL			RHR HEAT EXCHANGER
	C1.20	Head Circumferential Welds	VOL			RHR HEAT EXCHANGER
	C1.30	Tube-sheet-to-Shell Weld				N/A
C-B		PRESSURE RETAINING NOZZLE WELDS IN VESSELS				
	C2.10	Nozzles in Vessel $\leq \frac{1}{2}$ in. Nominal Thickness	SURF	CR-8	VT-2	RHR HEAT EXCHANGER
	C2.20	Nozzles in Vessel $> \frac{1}{2}$ IN. Nominal Thickness				N/A
C-C		INTEGRAL ATTACHMENTS FOR VESSELS, PIPING, PUMPS, AND VALVES				
		Pressure Vessels				
	C3.10	Integrally Welded Attachments	SURF			RHR HEAT EXCHANGER
		Piping				
	C3.40	Integrally Welded Attachments	SURF			



Commonwealth
Edison

INSERVICE INSPECTION PROGRAM

ISI - CLASS 1,2&3 COMPONENTS
QUAD CITIES NUCLEAR POWER STATION

UNIT - 1

CLASS 2

Page 12 of 115

Revision 2

Date 9-17-84

CODE CATEGORY	ITEM NUMBER	ITEM DESCRIPTION	SECT XI EXAM REQUIRED	RELIEF REQUESTS	ALTERNATE EXAM	REMARKS
C-D	C3.70	Pumps Integrally Welded Attachments				N/A
	C3.100	Valves Integrally Welded Attachments				N/A
		PRESSURE RETAINING BOLTING GREATER THAN 2 in. IN DIAMETER				
	C4.10	Pressure Vessels Bolts and Studs				N/A
	C4.20	Piping Bolts and Studs				N/A
	C4.30	Pumps Bolts and Studs				N/A
C-F	C4.40	Valves Bolts and Studs				N/A
		PRESSURE RETAINING WELDS IN PIPING				
	C5.10	Piping Welds $\leq \frac{1}{2}$ in. Nominal Wall Thickness				
	C5.11	Circumferential Weld	SURF			
	C5.12	Longitudinal Weld	SURF			



Commonwealth
Edison

INSERVICE INSPECTION PROGRAM

ISI -- CLASS 1,2 & 3 COMPONENTS
QUAD CITIES NUCLEAR POWER STATION

UNIT - 1

CLASS 2

Page 13 of 16

Revision 2

Date 9-17-84

CODE CATEGORY	ITEM NUMBER	ITEM DESCRIPTION	SECT XI EXAM REQUIRED	RELIEF REQUESTS	ALTERNATE EXAM	REMARKS
	C5.20	Piping Welds > 1/2 in. Nominal Wall Thickness				
	C5.21	Circumferential Weld	SURF AND VOL.			
	C5.22	Longitudinal Weld				N/A
	C5.30	Pipe Branch Connections				
	C5.31	Circumferential Weld	SURF	CR-10	VT-2	
	C5.32	Longitudinal Weld				N/A
C-G		PRESSURE RETAINING WELDS IN PUMPS AND VALVES				N/A
C-H		ALL PRESSURE RETAINING COMPONENTS				
		Pressure Vessels				
	C7.10	Pressure Retaining Components	VT-2			PRESSURE TEST
	C7.11	Pressure Retaining Components	VT-2			HYDROSTATIC TEST
		Piping				
	C7.20	Pressure Retaining Components	VT-2			PRESSURE TEST
	C7.21	Pressure Retaining Components	VT-2			HYDROSTATIC TEST
		Pumps				
	C7.30	Pressure Retaining Components	VT-2			PRESSURE TEST
	C7.31	Pressure Retaining Components	VT-2			HYDROSTATIC TEST



Commonwealth
Edison

INSERVICE INSPECTION PROGRAM

ISI - CLASS 1,2&3 COMPONENTS
QUAD CITIES NUCLEAR POWER STATION

UNIT - 1

CLASS 2

Page 14 of 15

Revision 2

Date 9-17-84

CODE CATEGORY	ITEM NUMBER	ITEM DESCRIPTION	SECT XI EXAM REQUIRED	RELIEF REQUESTS	ALTERNATE EXAM	REMARKS
	C7.40	Valves Pressure Retaining Components	VT-2			PRESSURE TEST
	C7.41	Pressure Retaining Components	VT-2			HYDROSTATIC TEST



Commonwealth
Edison

INSERVICE INSPECTION PROGRAM

ISI - CLASS 1,2&3 COMPONENTS
QUAD CITIES NUCLEAR POWER STATION

UNIT - 1

CLASS 3

Page 15 of 15

Revision 2

Date 9-17-84

CODE CATEGORY	ITEM NUMBER	ITEM DESCRIPTION	SECT XI EXAM REQUIRED	RELIEF REQUESTS	ALTERNATE EXAM	REMARKS
D-A		SYSTEMS IN SUPPORT OF REACTOR SHUTDOWN FUNCTION				N/A
D-B		SYSTEMS IN SUPPORT OF EMERGENCY CORE COOLING, CONTAINMENT HEAT REMOVAL, ATMOSPHERE CLEANUP, AND REACTOR RESIDUAL HEAT REMOVAL				
	D2.10	Pressure Retaining Components	VT-2 VT-2			FUNCTIONAL TEST HYDROSTATIC TEST
	D2.20	Integral Attachment - Component Supports and Restraints	VT-3			
	D2.30	Integral Attachment - Mechanical and Hydraulic Snubbers				N/A
	D2.40	Integral Attachment - Spring Type Supports				N/A
	D2.50	Integral Attachment - Constant Load Type Supports				N/A
	D2.60	Integral Attachment - Shock Absorbers				N/A
D-C		SYSTEMS IN SUPPORT OF RESIDUAL HEAT REMOVAL FROM SPENT FUEL STORAGE POOL				N/A



Commonwealth
Edison

INSERVICE INSPECTION PROGRAM

ISI - CLASS 1,2&3 COMPONENTS
QUAD CITIES NUCLEAR POWER STATION

UNIT - 2

CLASS 1

Page 1 of 15

Revision 2

Date 9-17-84

CODE CATEGORY	ITEM NUMBER	ITEM DESCRIPTION	SECT XI EXAM REQUIRED	RELIEF REQUESTS	ALTERNATE EXAM	REMARKS
B.A		PRESSURE RETAINING WELDS IN REACTOR VESSEL				
	B1.10	Shell Welds				
	B1.11	Circumferential	VOL	CR-1		
	B1.12	Longitudinal	VOL	CR-1		
	B1.20	Head Welds				
	B1.21	Circumferential	VOL	CR-2		
	B1.22	Meridional	VOL	CR-2		
	B1.30	Shell-to-Flange Weld	VOL			
	B1.40	Head-to-Flange Weld	VOL AND SURF			
	B1.50	Repair Welds				N/A
B.B		PRESSURE RETAINING WELDS IN VESSELS OTHER THAN REACTOR VESSELS				N/A
B.D		FULL PENETRATION WELDS OF NOZZLES IN VESSELS - INSPECTION PROGRAM B				
		Reactor Vessel				
	B1.90	Nozzle-to-Vessel Welds	VOL			
	B1.100	Nozzle Inside Radius Section	VOL			



Commonwealth
Edison

INSERVICE INSPECTION PROGRAM

ISI - CLASS 1,2&3 COMPONENTS
QUAD CITIES NUCLEAR POWER STATION

UNIT - 2

CLASS 1

Page 2 of 15

Revision 2 Date 9-17-84

CODE CATEGORY	ITEM NUMBER	ITEM DESCRIPTION	SECT XI EXAM REQUIRED	RELIEF REQUESTS	ALTERNATE EXAM	REMARKS
		Pressurizer				
	B3.110	Nozzle-to-Vessel Welds				N/A
	B3.120	Nozzle Inside Radius Section				N/A
		Steam Generators (Primary Side)				
	B3.130	Nozzle-to-Vessel Welds				N/A
	B3.140	Nozzle Inside Radius Section				N/A
		Heat Exchangers (Primary Side)				
	B3.150	Nozzle-to-Vessel Welds				N/A
	B3.160	Nozzle Inside Radius Section				N/A
B-K		PRESSURE RETAINING PARTIAL PENETRATION WELDS IN VESSELS				
	B4.10	Partial Penetration Welds				EXTERNAL SURFACES
	B4.11	Vessel Nozzles	VT-2			
	B4.12	Control Rod Drive Nozzles	VT-2			
	B4.13	Instrumentation Nozzles	VT-2			
		Pressurizer				
	B4.20	Heater Penetration Welds				N/A
B-F		PRESSURE RETAINING DISSIMILAR METAL WELDS				
		Reactor Vessel				
	B5.10	Nominal Pipe Size \geq 4 in.				



Commonwealth
Edison

INSERVICE INSPECTION PROGRAM

ISI - CLASS 1,2&3 COMPONENTS
QUAD CITIES NUCLEAR POWER STATION

UNIT - 2

CLASS 1

Page 3 of 15
Revision 2 Date 9-17-84

CODE CATEGORY	ITEM NUMBER	ITEM DESCRIPTION	SECT XI EXAM REQUIRED	RELIEF REQUESTS	ALTERNATE EXAM	REMARKS
	B5.11	Nozzle-to-Safe End Butt Welds Nominal Pipe Size < 4 in.	VOL AND SURF			
	B5.12	Nozzle-to-Safe End Butt Welds Nozzle-to-Safe End Socket Welds	SURF			N/A
	B5.20	Pressurizer Nominal Pipe Size \geq 4 in.				
	B5.21	Nozzle-to-Safe End Butt Welds Nominal Pipe Size < 4 in.				N/A
	B5.22	Nozzle-to-Safe End Butt Welds Nozzle-to-Safe End Socket Welds				N/A N/A
	B5.30	Steam Generator Nominal Pipe Size \geq 4 in.				
	B5.31	Nozzle-to-Safe End Butt Welds Nominal Pipe Size < 4 in.				N/A
	B5.32	Nozzle-to-Safe End Butt Welds Nozzle-to-Safe End Socket Welds				N/A N/A
	B5.40	Heat Exchangers Nominal Pipe Size \geq 4 in.				
	B5.41	Nozzle-to-Safe End Butt Welds Nominal Pipe Size < 4 in.				N/A
	B5.42	Nozzle-to-Safe End Butt Welds Nozzle-to-Safe End Socket Welds				N/A N/A
	B5.50	Piping Nominal Pipe Size \geq 4 in. Dissimilar Metal Butt Welds	VOL AND SURF			SEE FIG. IWB-2500-B



Commonwealth
Edison

INSERVICE INSPECTION PROGRAM

ISI - CLASS 1,2&3 COMPONENTS
QUAD CITIES NUCLEAR POWER STATION

UNIT - 2

CLASS 1

Page 4 of 15
Revision 2 Date 9-17-84

CODE CATEGORY	ITEM NUMBER	ITEM DESCRIPTION	SECT XI EXAM REQUIRED	RELIEF REQUESTS	ALTERNATE EXAM	REMARKS	
B-G-1	B5.51	Nominal Pipe Size < 4 in. Dissimilar Metal Butt Welds	SURF			N/A	
	B5.52	Dissimilar Metal Socket Welds					
		PRESSURE RETAINING BOLTING, GREATER THAN 2 in. IN DIAMETER					
		Reactor Vessel					
	B6.10	Closure Head Nuts	SURF				
	B6.20	Closure Studs, in place	VOL				
	B6.30	Closure Studs, when removed	SURF AND VOL				
	B6.40	Threads in Flange	VOL				
	B6.50	Closure Washers, Bushings	VT-1				
		Pressurizer					
	B6.60	Bolts and Studs					N/A
	B6.70	Flange Surface, when connection disassembled					N/A
	B6.80	Nuts, Bushings, and Washers					N/A
		Steam Generators					
	B6.90	Bolts and Studs					N/A
B6.100	Flange Surface, when connection disassembled		N/A				
B6.110	Nuts, Bushings, and Washers		N/A				
	Heat Exchangers						
B6.120	Bolts and Studs		N/A				



Commonwealth
Edison

INSERVICE INSPECTION PROGRAM

ISI - CLASS 1,2&3 COMPONENTS
QUAD CITIES NUCLEAR POWER STATION

UNIT - 2

CLASS 1

Page 5 of 15

Revision 2

Date 9-17-84

CODE CATEGORY	ITEM NUMBER	ITEM DESCRIPTION	SECT XI EXAM REQUIRED	RELIEF REQUESTS	ALTERNATE EXAM	REMARKS
	B6.130	Flange Surface, when connection disassembled				N/A
	B6.140	Nuts, Bushings, and Washers				N/A
		Piping				
	B6.150	Bolts and Studs				N/A
	B6.160	Flange Surface, when connection disassembled				N/A
	B6.170	Nuts, Bushings, and Washers				N/A
		Pumps				
	B6.180	Bolts and Studs	VOL			
	B6.190	Flange Surface, when connection disassembled	VT-1			
	B6.200	Nuts, Bushings, and Washers	VT-1			
		Valves				
	B6.210	Bolts and Studs				N/A
	B6.220	Flange Surface, when connection disassembled				N/A
	B6.230	Nuts, Bushings, and Washers				N/A
B-G-2		PRESSURE RETAINING BOLTING, 2 in. AND LESS IN DIAMETER				
		Reactor Vessel				
	B7.10	Bolts, Studs, and Nuts				N/A



Commonwealth
Edison

INSERVICE INSPECTION PROGRAM

ISI - CLASS 1,2&3 COMPONENTS
QUAD CITIES NUCLEAR POWER STATION

UNIT - 2

CLASS 1

Page 6 of 15

Revision 2

Date 9-17-84

CODE CATEGORY	ITEM NUMBER	ITEM DESCRIPTION	SECT XI EXAM REQUIRED	RELIEF REQUESTS	ALTERNATE EXAM	REMARKS
	07.20	Pressurizer Bolts, Studs, and Nuts				N/A
	07.30	Steam Generators Bolts, Studs, and Nuts				N/A
	07.40	Heat Exchangers Bolts, Studs, and Nuts				N/A
	07.50	Piping Bolts, Studs, and Nuts	VT-1			
	07.60	Pumps Bolts, Studs, and Nuts				N/A
	07.70	Valves Bolts, Studs, and Nuts	VT-1			
	07.80	CRD Housings Bolts, Studs, and Nuts	VT-1			WHEN DISASSEMBLED
B-H		INTEGRAL ATTACHMENTS FOR VESSELS				
	08.10	Reactor Vessel Integrally Welded Attachments	SURF			VESSEL SUPPORT SKIRT; SEE FIG. IWB-2500-13 LIFTING LUGS, STABILIZER LUGS SEE FIG. IWB-2500-15



Commonwealth
Edison

INSERVICE INSPECTION PROGRAM

ISI - CLASS 1,2&3 COMPONENTS
QUAD CITIES NUCLEAR POWER STATION

UNIT - 2

CLASS 1

Page 7 of 15

Revision 2

Date 9-17-84

CODE CATEGORY	ITEM NUMBER	ITEM DESCRIPTION	SECT XI EXAM REQUIRED	RELIEF REQUESTS	ALTERNATE EXAM	REMARKS
	08.20	Pressurizer Integrally Welded Attachments				N/A
	08.30	Steam Generator Integrally Welded Attachments				N/A
	08.40	Heat Exchangers Integrally Welded Attachments				N/A
B-J		PRESSURE RETAINING WELDS IN PIPING				
	09.10	Nominal Pipe Size \geq 4 in.				
	09.11	Circumferential Welds	SURF AND VOL	CR-3, CR-4		
	09.12	Longitudinal Welds	SURF AND VOL	CR-4		
	09.20	Nominal Pipe Size < 4 in.				
	09.21	Circumferential Welds	SURF			
	09.22	Longitudinal Welds	SURF			
	09.30	Branch Pipe Connection Welds				
	09.31	Nominal Pipe Size \geq 4 in.	SURF AND VOL	CR-5	VT-2	
	09.32	Nominal Pipe Size < 4 in.	SURF			
	09.40	Socket Welds				N/A



Commonwealth
Edison

INSERVICE INSPECTION PROGRAM

ISI - CLASS 1,2&3 COMPONENTS
QUAD CITIES NUCLEAR POWER STATION

UNIT - 2

CLASS 1

Page 8 of 15
Revision 2 Date 9-17-84

CODE CATEGORY	ITEM NUMBER	ITEM DESCRIPTION	SECT XI EXAM REQUIRED	RELIEF REQUESTS	ALTERNATE EXAM	REMARKS
B-K-1		INTEGRAL ATTACHMENTS FOR PIPING, PUMPS AND VALVES				
		Piping				
	B10.10	Integrally Welded Attachments	SURF			SEE FIG. IWB-2500-13,15
		Pumps				
	B10.20	Integrally Welded Attachments	SURF			SEE FIG. IWB-2500-13,15
		Valves				
	B10.30	Integrally Welded Attachments	SURF			SEE FIG. IWB-2500-13,15
B-L-1, B-M-1		PRESSURE RETAINING WELDS IN PUMP CASINGS AND VALVE BODIES				N/A
B-L-2, B-M-2		PUMP CASINGS AND VALVE BODIES				
	B12.20	Pump Casing	VT-3	CR-6		WHEN DISASSEMBLED
	B12.40	Valve Body, Exceeding 4 in. Nominal Pipe Size	VT-3	CR-7		WHEN DISASSEMBLED
B-N-1		INTERIOR OF REACTOR VESSEL				
		Reactor Vessel				
	B11.10	Vessel Interior	VT-3			PER TABLE IWB-2500-1, CATEGORY B-N-1



Commonwealth
Edison

INSERVICE INSPECTION PROGRAM

ISI - CLASS 1,2&3 COMPONENTS
QUAD CITIES NUCLEAR POWER STATION

UNIT - 2

CLASS 1

Page 9 of 15
Revision 2 Date 9-17-84

CODE CATEGORY	ITEM NUMBER	ITEM DESCRIPTION	SECT XI EXAM REQUIRED	RELIEF REQUESTS	ALTERNATE EXAM	REMARKS
	B13.20	Reactor Vessel (BWR) Interior Attachments	VT-1			ACCESSIBLE WELDS ACCESSIBLE SURFACES
	B13.21	Core Support Structure	VT-1			
	B13.30	Reactor Vessel (PWR) Core Support Structure				N/A
B-O		PRESSURE RETAINING WELDS IN CONTROL ROD HOUSINGS				
	B14.10	Reactor Vessel Welds in CRD Housing	VOL	EX-2		EX-2 APPLIED TO THESE HOUSINGS DUE TO CONFIGURATION
B-P		ALL PRESSURE RETAINING COMPONENTS				
	B15.10	Reactor Vessel Pressure Retaining Boundary	VT-2			LEAKAGE TEST
	B15.11	Pressure Retaining Boundary	VT-2			HYDROSTATIC TEST
	B15.20	Pressurizer Pressure Retaining Boundary				N/A
	B15.21	Pressure Retaining Boundary				N/A
	B15.30	Steam Generators Pressure Retaining Boundary				N/A
	B15.31	Pressure Retaining Boundary				N/A



Commonwealth
Edison

INSERVICE INSPECTION PROGRAM

ISI - CLASS 1,2&3 COMPONENTS
QUAD CITIES NUCLEAR POWER STATION

UNIT - 2

CLASS 1

Page 10 of 15
Revision 2 Date 9-17-84

CODE CATEGORY	ITEM NUMBER	ITEM DESCRIPTION	SECT XI EXAM REQUIRED	RELIEF REQUESTS	ALTERNATE EXAM	REMARKS
		Heat Exchangers				
	B15.40	Pressure Retaining Boundary				N/A
	B15.41	Pressure Retaining Boundary				N/A
		Piping				
	B15.50	Pressure Retaining Boundary	VT-2			LEAKAGE TEST
	B15.51	Pressure Retaining Boundary	VT-2			HYDROSTATIC TEST
		Pumps				
	B15.60	Pressure Retaining Boundary	VT-2			LEAKAGE TEST
	B15.61	Pressure Retaining Boundary	VT-2			HYDROSTATIC TEST
		Valves				
	B15.70	Pressure Retaining Boundary	VT-2			LEAKAGE TEST
	B15.71	Pressure Retaining Boundary	VT-2			HYDROSTATIC TEST
B-Q		STEAM GENERATOR TUBING				N/A



Commonwealth
Edison

INSERVICE INSPECTION PROGRAM

ISI - CLASS 1,2&3 COMPONENTS
QUAD CITIES NUCLEAR POWER STATION

UNIT - 2

CLASS 2

Page 11 of 15

Revision 2

Date 9-17-84

CODE CATEGORY	ITEM NUMBER	ITEM DESCRIPTION	SECT XI EXAM REQUIRED	RELIEF REQUESTS	ALTERNATE EXAM	REMARKS
C-A		PRESSURE RETAINING WELDS IN PRESSURE VESSELS				
	C1.10	Shell Circumferential Welds	VOL			RHR HEAT EXCHANGER
	C1.20	Head Circumferential Welds	VOL			RHR HEAT EXCHANGER
	C1.30	Tubesheet-to-Shell Weld				N/A
C-B		PRESSURE RETAINING NOZZLE WELDS IN VESSELS				
	C2.10	Nozzles in Vessel $\leq \frac{1}{2}$ in. Nominal Thickness	SURF	CR-B	VT-2	
	C2.20	Nozzles in Vessel $> \frac{1}{2}$ IN. Nominal Thickness				N/A
C-C		INTEGRAL ATTACHMENTS FOR VESSELS, PIPING, PUMPS, AND VALVES				
		Pressure Vessels				
	C3.10	Integrally Welded Attachments	SURF			RHR HEAT EXCHANGER
		Piping				
	C3.40	Integrally Welded Attachments	SURF			



Commonwealth
Edison

INSERVICE INSPECTION PROGRAM

ISI - CLASS 1,2&3 COMPONENTS
QUAD CITIES NUCLEAR POWER STATION

UNIT - 2

CLASS 2

Page 12 of 15

Revision 2

Date 9-17-84

CODE CATEGORY	ITEM NUMBER	ITEM DESCRIPTION	SECT XI EXAM REQUIRED	RELIEF REQUESTS	ALTERNATE EXAM	REMARKS
C-D	C3.70	Pumps Integrally Welded Attachments				N/A
	C3.100	Valves Integrally Welded Attachments				N/A
		PRESSURE RETAINING BOLTING GREATER THAN 2 in. IN DIAMETER				
	C4.10	Pressure Vessels Bolts and Studs				N/A
	C4.20	Piping Bolts and Studs				N/A
	C4.30	Pumps Bolts and Studs	Vol			N/A
	C4.40	Valves Bolts and Studs				N/A
C-F		PRESSURE RETAINING WELDS IN PIPING				
	C5.10	Piping Welds $\leq \frac{1}{2}$ in. Nominal Wall Thickness				
	C5.11	Circumferential Weld	SURF			
	C5.12	Longitudinal Weld	SURF			



Commonwealth
Edison

INSERVICE INSPECTION PROGRAM

ISI - CLASS 1,2&3 COMPONENTS
QUAD CITIES NUCLEAR POWER STATION

UNIT - 2

CLASS 2

Page 13 of 15

Revision 2

Date 9-17-84

CODE CATEGORY	ITEM NUMBER	ITEM DESCRIPTION	SECT XI EXAM REQUIRED	RELIEF REQUESTS	ALTERNATE EXAM	REMARKS
	C5.20	Piping Welds > 1/2 in. Nominal Wall Thickness				
	C5.21	Circumferential Weld	SURF AND VOL.			
	C5.22	Longitudinal Weld				N/A
	C5.30	Pipe Branch Connections				
	C5.31	Circumferential Weld	SURF	CR-10	VT-2	
	C5.32	Longitudinal Weld				N/A
C-G		PRESSURE RETAINING WELDS IN PUMPS AND VALVES				N/A
C-H		ALL PRESSURE RETAINING COMPONENTS				
		Pressure Vessels				
	C7.10	Pressure Retaining Components	VT-2			PRESSURE TEST
	C7.11	Pressure Retaining Components	VT-2			HYDROSTATIC TEST
		Piping				
	C7.20	Pressure Retaining Components	VT-2			PRESSURE TEST
	C7.21	Pressure Retaining Components	VT-2			HYDROSTATIC TEST
		Pumps				
	C7.30	Pressure Retaining Components	VT-2			PRESSURE TEST
	C7.31	Pressure Retaining Components	VT-2			HYDROSTATIC TEST



Commonwealth
Edison

INSERVICE INSPECTION PROGRAM

ISI - CLASS 1,2&3 COMPONENTS
QUAD CITIES NUCLEAR POWER STATION

UNIT - 2

CLASS 2

Page 14 of 15

Revision 2

Date 9-17-84

CODE CATEGORY	ITEM NUMBER	ITEM DESCRIPTION	SECT XI EXAM REQUIRED	RELIEF REQUESTS	ALTERNATE EXAM	REMARKS
		Valves				
	C7.40	Pressure Retaining Components	VT-2			PRESSURE TEST
	C7.41	Pressure Retaining Components	VT-2			HYDROSTATIC TEST



Commonwealth
Edison

INSERVICE INSPECTION PROGRAM

ISI - CLASS 1,2&3 COMPONENTS
QUAD CITIES NUCLEAR POWER STATION

UNIT - 2

CLASS 3

Page 15 of 15

Revision 2

Date 9-17-84

CODE CATEGORY	ITEM NUMBER	ITEM DESCRIPTION	SECT XI EXAM REQUIRED	RELIEF REQUESTS	ALTERNATE EXAM	REMARKS
D-A		SYSTEMS IN SUPPORT OF REACTOR SHUTDOWN FUNCTION				N/A
D-B		SYSTEMS IN SUPPORT OF EMERGENCY CORE COOLING, CONTAINMENT HEAT REMOVAL, ATMOSPHERE CLEANUP, AND REACTOR RESIDUAL HEAT REMOVAL				
	D2.10	Pressure Retaining Components	VT-2 VT-2			FUNCTIONAL TEST HYDROSTATIC TEST
	D2.20	Integral Attachment - Component Supports and Restraints	VT-3			
	D2.30	Integral Attachment - Mechanical and Hydraulic Snubbers				N/A
	D2.40	Integral Attachment - Spring Type Supports				N/A
	D2.50	Integral Attachment - Constant Load Type Supports				N/A
	D2.60	Integral Attachment - Shock Absorbers				N/A
D-C		SYSTEMS IN SUPPORT OF RESIDUAL HEAT REMOVAL FROM SPENT FUEL STORAGE POOL				N/A

TABLES FOR INSERVICE INSPECTION PROGRAM OF COMPONENT SUPPORTS

QUAD CITIES UNITS 1 & 2



Commonwealth
Edison

INSERVICE INSPECTION PROGRAM

ISI - CLASS 1,2&3 COMPONENTS
QUAD CITIES NUCLEAR POWER STATION

UNIT - 1

CLASS 1

Page 1 of 8

Revision 2

Date 9-17-84

CODE CATEGORY	ITEM NUMBER	ITEM DESCRIPTION	SECT XI EXAM REQUIRED	RELIEF REQUESTS	ALTERNATE EXAM	REMARKS
F-A		PLATE AND SHELL TYPE SUPPORTS				
	F-1	Mechanical Attachments, including bolting	VT-3			
	F-2	Welded Attachments				N/A
	F-3	Component displacement	VT-3			
		Settings of guides and stops	VT-3			
		Misalignment of supports	VT-3			
		Assembly of support items	VT-3			
F-B		LINEAR TYPE SUPPORTS				
	F-1	Mechanical Attachments, including bolting	VT-3			
	F-2	Welded Attachments	VT-3			
	F-3	Component displacement	VT-3			
		Settings of guides and stops	VT-3			
		Misalignment of supports	VT-3			
		Assembly of support items	VT-3			
F-C		COMPONENT STANDARD SUPPORTS				
	F-1	Mechanical Attachments, including bolting	VT-3			



Commonwealth
Edison

INSERVICE INSPECTION PROGRAM

ISI -- CLASS 1,2&3 COMPONENTS
QUAD CITIES NUCLEAR POWER STATION

Page 2 of 8
Revision 2 Date 9-17-84

UNIT - 1

CLASS 1

CODE CATEGORY	ITEM NUMBER	ITEM DESCRIPTION	SECT XI EXAM REQUIRED	RELIEF REQUESTS	ALTERNATE EXAM	REMARKS
	F-2	Welded Attachments	VT-3			
	F-3	Component displacement Settings of guides and stops Misalignment of supports Assembly of support items	VT-3 VT-3 VT-3 VT-3			
	F-4	Spring type supports Constant load type supports Shock absorbers Hydraulic and mechanical type snubbers	VT-4 VT-4 VT-4 VT-4			



Commonwealth
Edison

INSERVICE INSPECTION PROGRAM

ISI - CLASS 1,2&3 COMPONENTS
QUAD CITIES NUCLEAR POWER STATION

UNIT - 1

CLASS 2

Page 3 of 8

Revision 2

Date 9-17-84

CODE CATEGORY	ITEM NUMBER	ITEM DESCRIPTION	SECT XI EXAM REQUIRED	RELIEF REQUESTS	ALTERNATE EXAM	REMARKS
F-A		PLATE AND SHELL TYPE SUPPORTS				N/A
F-B		LINEAR TYPE SUPPORTS				
	F-1	Mechanical Attachments, including bolting	VT-3			
	F-2	Welded Attachments	VT-3			
	F-3	Component displacement	VT-3			
		Settings of guides and stops	VT-3			
		Misalignment of supports	VT-3			
		Assembly of support items	VT-3			
F-C		COMPONENT STANDARD SUPPORTS				
	F-1	Mechanical Attachments, including bolting	VT-3			
	F-2	Welded Attachments	VT-3			
	F-3	Component displacement	VT-3			
		Settings of guides and stops	VT-3			
		Misalignment of supports	VT-3			
		Assembly of support items	VT-3			
	F-4	Spring type supports	VT-4			
		Constant load type supports	VT-4			
		Shock absorbers	VT-4			
		Hydraulic and mechanical type snubbers	VT-4			



Commonwealth
Edison

INSERVICE INSPECTION PROGRAM

ISI - CLASS 1,2&3 COMPONENTS
QUAD CITIES NUCLEAR POWER STATION

UNIT - 1

CLASS 3

Page 4 of 8

Revision 2

Date 9-17-84

CODE CATEGORY	ITEM NUMBER	ITEM DESCRIPTION	SECT XI EXAM REQUIRED	RELIEF REQUESTS	ALTERNATE EXAM	REMARKS
F-A		PLATE AND SHELL TYPE SUPPORTS				N/A
F-B		LINEAR TYPE SUPPORTS				
	F-1	Mechanical Attachments, including bolting	VT-3			
	F-2	Welded Attachments	VT-3			
	F-3	Component displacement	VT-3			
		Settings of guides and stops	VT-3			
		Misalignment of supports	VT-3			
		Assembly of support items	VT-3			
F-C		COMPONENT STANDARD SUPPORTS				
	F-1	Mechanical Attachments, including bolting	VT-3			
	F-2	Welded Attachments	VT-3			
	F-3	Component displacement	VT-3			
		Settings of guides and stops	VT-3			
		Misalignment of supports	VT-3			
		Assembly of support items	VT-3			
	F-4	Spring type supports	VT-4			
		Constant load type supports	VT-4			
		Shock absorbers	VT-4			
		Hydraulic and mechanical type snubbers	VT-4			



Commonwealth
Edison

INSERVICE INSPECTION PROGRAM

ISI - CLASS 1,2&3 COMPONENTS
QUAD CITIES NUCLEAR POWER STATION

UNIT - 2

CLASS 1

Page 5 of 8

Revision 2 Date 9-17-84

CODE CATEGORY	ITEM NUMBER	ITEM DESCRIPTION	SECT XI EXAM REQUIRED	RELIEF REQUESTS	ALTERNATE EXAM	REMARKS
F-A		PLATE AND SHELL TYPE SUPPORTS				
	F-1	Mechanical Attachments, including bolting	VT-3			
	F-2	Welded Attachments				N/A
	F-3	Component displacement	VT-3			
		Settings of guides and stops	VT-3			
		Misalignment of supports	VT-3			
		Assembly of support items	VT-3			
F-B		LINEAR TYPE SUPPORTS				
	F-1	Mechanical Attachments, including bolting	VT-3			
	F-2	Welded Attachments	VT-3			
	F-3	Component displacement	VT-3			
		Settings of guides and stops	VT-3			
		Misalignment of supports	VT-3			
		Assembly of support items	VT-3			
F-C		COMPONENT STANDARD SUPPORTS				
	F-1	Mechanical Attachments, including bolting	VT-3			



Commonwealth
Edison

INSERVICE INSPECTION PROGRAM

ISI - CLASS 1,2&3 COMPONENTS
QUAD CITIES NUCLEAR POWER STATION

UNIT - 2

CLASS 1

Page 6 of 8

Revision 2

Date 9-17-84

CODE CATEGORY	ITEM NUMBER	ITEM DESCRIPTION	SECT XI EXAM REQUIRED	RELIEF REQUESTS	ALTERNATE EXAM	REMARKS
	F-2	Welded Attachments	VT-3			
	F-3	Component displacement	VT-3			
		Settings of guides and stops	VT-3			
		Misalignment of supports	VT-3			
		Assembly of support items	VT-3			
	F-4	Spring type supports	VT-4			
		Constant load type supports	VT-4			
		Shock absorbers	VT-4			
		Hydraulic and mechanical type snubbers	VT-4			



Commonwealth
Edison

INSERVICE INSPECTION PROGRAM

ISI - CLASS 1,2&3 COMPONENTS
QUAD CITIES NUCLEAR POWER STATION

UNIT - 2

CLASS 2

Page 7 of 8

Revision 2

Date 9-17-84

CODE CATEGORY	ITEM NUMBER	ITEM DESCRIPTION	SECT XI EXAM REQUIRED	RELIEF REQUESTS	ALTERNATE EXAM	REMARKS
F-A		PLATE AND SHELL TYPE SUPPORTS				N/A
F-B		LINEAR TYPE SUPPORTS				
	F-1	Mechanical Attachments, including bolting	VT-3			
	F-2	Welded Attachments	VT-3			
	F-3	Component displacement	VT-3			
		Settings of guides and stops	VT-3			
		Misalignment of supports	VT-3			
		Assembly of support items	VT-3			
F-C		COMPONENT STANDARD SUPPORTS				
	F-1	Mechanical Attachments, including bolting	VT-3			
	F-2	Welded Attachments	VT-3			
	F-3	Component displacement	VT-3			
		Settings of guides and stops	VT-3			
		Misalignment of supports	VT-3			
		Assembly of support items	VT-3			
	F-4	Spring type supports	VT-4			
		Constant load type supports	VT-4			
		Shock absorbers	VT-4			
		Hydraulic and Mechanical Type Snubbers	VT-4			



Commonwealth
Edison

INSERVICE INSPECTION PROGRAM

ISI - CLASS 1,2&3 COMPONENTS
QUAD CITIES NUCLEAR POWER STATION

UNIT - 2

CLASS 3

Page 8 of 8

Revision 2

Date 9-17-84

CODE CATEGORY	ITEM NUMBER	ITEM DESCRIPTION	SECT XI EXAM REQUIRED	RELIEF REQUESTS	ALTERNATE EXAM	REMARKS
F-A		PLATE AND SHELL TYPE SUPPORTS				N/A
F-B		LINEAR TYPE SUPPORTS				
	F-1	Mechanical Attachments, including bolting	VT-3			
	F-2	Welded Attachments	VT-3			
	F-3	Component displacement	VT-3			
		Settings of guides and stops	VT-3			
		Misalignment of supports	VT-3			
		Assembly of support items	VT-3			
F-C		COMPONENT STANDARD SUPPORTS				
	F-1	Mechanical Attachments, including bolting	VT-3			
	F-2	Welded Attachments	VT-3			
	F-3	Component displacement	VT-3			
		Settings of guides and stops	VT-3			
		Misalignment of supports	VT-3			
		Assembly of support items	VT-3			
	F-4	Spring type supports	VT-4			
		Constant load type supports	VT-4			
		Shock absorbers	VT-4			
		Hydraulic and mechanical type snubbers	VT-4			

SECTION 2.3

RELIEF REQUESTS FOR INSERVICE INSPECTION PROGRAM

RELIEF REQUEST NO. CR-1

I. IDENTIFICATION OF COMPONENTS AND IMPRACTICAL CODE REQUIREMENTS

The reactor vessel is designed with one circumferential and six longitudinal welds in the core beltline region as shown on Figure 1a.

The ASME Boiler and Pressure Vessel Code, Section XI, 1980 Edition through the Winter 1980 Addenda requires a volumetric examination of 100 percent of the length of one beltline longitudinal weld and one beltline circumferential weld each ten year interval (Code Category B-A).

Relief is requested from the above mentioned Code requirements on the basis of inaccessibility.

II. BASIS FOR RELIEF

Accessibility for inspection of these welds was not provided for in the original plant design which occurred prior to the issuance of Section XI inservice inspection requirements.

As indicated on Figure 1a, examination from the reactor vessel outer surface is precluded due the close proximity to the

biological shield wall and obstruction by the vessel insulation. The mirror type insulation consists of interlocking panels which were not designed to be easily removable at the weld locations. Furthermore, the annular dimensions between the shield wall and the insulation is not sufficient to allow direct access to personnel. Access through the biological shield wall is only provided at reactor vessel nozzle locations, however, there are no nozzle penetrations in the belt line region.

Examination of the beltline region welds from inside the vessel is impeded by vessel internal design features. The core shroud, jet pumps, and various brackets welded to the vessel wall are not designed to be removable.

III. ALTERNATE PROVISIONS

Currently, it is not feasible to perform the required volumetric examinations on these beltline region welds. Because there are no accessible circumferential welds, Commonwealth Edison will only increase the examinations of accessible longitudinal welds to achieve an examination sample equivalent to the category B-A (item B1.12) welds for which relief is requested. Station's procedure will be revised to ensure the performance of the alternative examinations.

RELIEF REQUEST NO. CR-2

I. IDENTIFICATION OF COMPONENTS AND IMPRACTICAL CODE REQUIREMENTS

The reactor vessel contains thirteen longitudinal welds and six circumferential welds in the shell sections and bottom head which are inaccessible for examination, in addition to the beltline region welds addressed in Relief Request CR-1.

Section XI of the ASME Boiler and Pressure Vessel Code, 1980 Edition through the Winter 1980 Addenda requires a volumetric examination of 100 percent of the length of one meridional head weld and one circumferential head weld each inspection interval (Code Category B-A).

As shown on Figure 1a and 1b, all of the reactor vessel closure head welds are fully accessible for examination. The bottom head welds, however, are inaccessible for examination.

II. BASIS FOR RELIEF

As discussed in Relief Request CR-1, accessibility for examination of these welds was not considered in the plant design. The bottom head welds cannot be examined because of the limited physical access, the inability to remove vessel

insulation panels, and also because of interference from the forest of control rod drive and instrumentation penetrations.

III. ALTERNATE PROVISIONS

Currently, it is not feasible to perform the required volumetric examinations on the bottom head welds. Commonwealth Edison will, however, keep abreast of improvements in state-of-the-art NDE techniques that could provide a viable means of examination.

RELIEF REQUEST NO. CR-3

I. IDENTIFICATION OF COMPONENTS AND IMPRACTICAL CODE REQUIREMENTS

Two Class-1 piping welds in Unit 2 and one weld in Unit 1 are physically inaccessible for examination. These welds are in the Control Rod Drive System on line number 0308-4". These welds cannot be examined because of interference from a structural support as shown on Figure 4.

Section XI of the ASME Boiler and Pressure Vessel Code, 1980 Edition including the Winter 1980 Addenda requires that twenty-five percent of the total number of circumferential pipe welds be volumetrically examined each ten year interval (Code Category B-J).

It is unlikely that these welds be inspectable at anytime during the plant life. Relief is, therefore, requested from performing the volumetric examination requirements of Section XI.

II. BASIS FOR RELIEF

The implications of this exemption are minimal due to the fact that safety margins inherent in the design of the subject welds are typical of those in all other welds in the Class-1 systems. Exempting these three welds from the total inspection sampling program will have negligible statistical significance.

III. ALTERNATE PROVISIONS

No alternate or augmented examinations are feasible or necessary in this case. The examinations required by IWB-5000 will, however, be conducted in accordance with the Code.

RELIEF REQUEST NO. CR-4

I. IDENTIFICATION OF COMPONENTS AND IMPRACTICAL CODE
REQUIREMENTS

Each of the lines listed below penetrates the primary containment by means of a penetration assembly similar in design to that shown in Figure-2. These Class-1 lines, due to the design of the penetration assembly, have one circumferential pressure retaining weld that is inaccessible for volumetric examination.

CRD RETURN - 0308-4"

RHR - 1012A&B-16", 1025-20"

Rx WATER CLEANUP - 1202-6"

CORE SPRAY - 1403-10", 1404-10"

HPCI - 2305-10"

MAIN STEAM 3001A,B,C,D-20"

FEEDWATER 3204A&B-18"

The ASME Boiler and Pressure Vessel Code, Section XI, 1980 Edition through the Winter 1980 Addenda requires a volumetric and surface examination on Class-1 welds (Code Category B-J).

Since this requirement is impractical due to plant design, relief is requested from the above stated examination requirements.

II. BASIS FOR RELIEF

As stated in 10CFR50.55a (g)(1) for plants whose construction permits were issued prior to January 1, 1971, components shall meet Section XI requirements to the extent practical. Since examination requirements for these welds did not exist at the time Quad Cities Station was designed, accessibility for their examination was not a prime consideration. Figure-2 clearly illustrates the design constraints which make it extremely impractical to the examine the subject welds by volumetric or surface techniques. Commonwealth Edison feels that this constitutes a basis for relief from the volumetric examination requirements of Section XI.

The safety implications of this exemption are minimal due to the fact that the safety margins in the subject welds are typical of those in all welds in the applicable systems. Since the exempted welds represent only a small fraction of the total number of circumferential, Category B-J welds in these systems (14 out of 291, and 14 out of 280, Unit 1 and 2 respectively), the statistical significance to the inspection sampling program due to exempting these welds is expected to be negligible.

III. ALTERNATE PROVISIONS

The first pressure boundary weld outside the containment on each of these process pipes will be volumetrically examined, where practical, over 100% of its length during each inspection interval. The examinations required by IWB-5000 will also be conducted.

Station's procedure will be revised to ensure the performance of the alternative volumetric examinations.

RELIEF REQUEST NO. CR-5

I. IDENTIFICATION OF COMPONENTS AND IMPRACTICAL CODE REQUIREMENTS

The design of certain Class-1 branch pipe connection welds calls for the use of reinforcement saddles. These saddles are fillet welded over the actual pressure retaining branch pipe to main pipe weld, completely encasing it as illustrated on Figure 3. There are four such welds that are greater than 4 inches in diameter.

Section XI of the ASME Boiler and Pressure Vessel Code, 1980 Edition through the Winter 1980 Addenda requires that branch pipe connection welds exceeding four inches diameter be surface and volumetrically examined. Twenty-five percent of these welds are required to be examined each inspection interval (Code Category B-J).

Relief is requested from this requirement due to the physical inaccessibility of the design.

II. BASIS FOR RELIEF

The fabrication of these joints precludes any type of surface examination or meaningful volumetric examination. Additional

assurance of the continued integrity of joints fabricated in this fashion is afforded by the fact that the reinforcement saddle strengthens the joint and reduces the stresses on the internal weld.

III. ALTERNATE PROVISIONS

Surface examination of the saddle fillet welds will be performed in lieu of the Code required examination and a visual examination of these joints for evidence of leakage will be conducted during the pressure tests required by IWB-5000.

Station's procedure will be revised to ensure the performance of the alternative surface examination.

RELIEF REQUEST NO. CR-6

I. IDENTIFICATION OF COMPONENTS AND IMPRACTICAL CODE REQUIREMENTS

Each Quad Cities Unit has an ISI Class-1 recirculation pump in each of the two 28-inch diameter recirculation loops. These pumps function during normal reactor operation to provide forced recirculation through the core.

The ASME Boiler and Pressure Vessel Code, Section XI, 1980 Edition through the Winter 1980 Addenda requires that one of these recirculation pumps be examined visually during each inspection interval. Specifically, the area of examination includes all pump internal pressure boundary surfaces.

As discussed, in detail below, Commonwealth Edison requests relief from the Section XI examination requirement to visually examine the recirculation pump internal surfaces on the basis of impracticality.

II. BASIS FOR RELIEF

The basis for this relief request is predicated on the following two points:

- 1) to complete the subject examination, large expenditures of manhours and man-rem are required with essentially no compensating increase in plant safety, and
- 2) the structural integrity afforded by the pump casing material utilized will not significantly degrade over the lifetime of the pump.

Based on data compiled from an actual recirculation pump disassembly, it is expected that approximately 1000 man-hours and 50 man-rem exposure would be required to disassemble, inspect, and reassemble one pump. Performing this visual examination under adverse conditions such as high dose rate (30-40 R/hr) and poor as-cast surface condition, realistically, provides little additional information as to the pump casing integrity.

The recirculation pump casing material, cast stainless steel (ASTM A351-CF-8), is widely used in the nuclear industry and has performed extremely well. The presence of some delta ferrite (typically 5% or more) imparts substantially increased resistance to intergranular stress corrosion cracking. The delta ferrite also results in improved pitting corrosion resistance in chloride containing environments.

Commonwealth Edison feels that adequate safety margins are inherent in the basic pump design and that the health and safety of the public will not be adversely effected by performing the visual examination of the pump internal pressure boundary surfaces only when the pumps are required to be disassembled for maintenance.

III. ALTERNATE PROVISIONS

As stated above, it is not felt that the visual examination required by Code each ten year interval is warranted. However, as standard maintenance practice dictates, when a pump of this type is disassembled for maintenance examination of the pump internals and internal pressure boundary surfaces will be performed, to the extent practical.

RELIEF REQUEST NO. CR-7

I. IDENTIFICATION OF COMPONENTS AND IMPRACTICAL CODE REQUIREMENTS

In the Class-1 system there are 51 valves which are greater than four inches nominal pipe size. These valves vary in size, design, and manufacturer but are all manufactured from either cast stainless steel or carbon steel. None of the valve body casings are welded.

Section XI of the ASME Code, 1980 Edition through the Winter 1980 Addenda requires that a visual examination of the internal pressure boundary surfaces of one valve in each group of valves of the same constructional design and manufacturing method that perform similar functions in the system. These examinations are required to be completed each inspection interval. (Code Category B-M-2)

Since these examinations must be met whether or not the valves have to be disassembled for maintenance, this requirement is considered impractical.

II. BASIS FOR RELIEF

The requirement to disassemble primary system valves for the sole purpose of performing a visual examination of the internal pressure boundary surfaces has only a very small potential of increasing plant safety margins and a very disproportionate impact on expenditures of plant manpower and radiation exposure.

Performing these visual examinations, under such adverse conditions as high dose rates (10 R/hr) and poor as-cast surface condition, realistically, provides little additional information as to the valve casing integrity.

For approximately 20 percent of these valves, the reactor vessel core must be completely unloaded and the vessel drained to permit disassembly for examination.

The performance of both carbon and stainless cast valve bodies has been excellent in all BWR applications. Based on this experience and both industry and regulatory acceptance of these alloys, continued excellent service performance is anticipated.

A more practical approach that would essentially provide an equivalent sampling program and significantly reduced radiation exposure to plant personnel is to inspect the internal pressure boundary of only those valves that require disassembly for

maintenance purposes. This would still provide a reasonable sampling of primary system values and give adequate assurance that the integrity of these components is being maintained.

III. ALTERNATE PROVISIONS

An examination of the internal pressure boundary surfaces will be performed, to the extent practical, each time a valve is disassembled for maintenance purposes.

RELIEF REQUEST NO. CR-8

I. IDENTIFICATION OF COMPONENTS AND IMPRACTICAL CODE REQUIREMENTS

There are two 18" diameter nozzles in the Class-2 portion of each of the two RHR System heat exchangers that are fabricated with reinforcement saddles. These saddles are fillet welded over the actual pressure retaining nozzle to shell weld. The configuration is shown on Figure 5.

Section XI of the ASME Boiler and Pressure Vessel Code, 1980 Edition through the Winter 1980 Addenda requires surface and volumetric examinations of two of these four nozzle-to-shell welds in the inspection interval. This requirement is impractical due to inaccessibility.

II. BASIS FOR RELIEF

The fabrication of these nozzle-to-shell welds precludes any type of volumetric or surface examination. The design does, however, provide additional strength at the joint and results in lower stresses at the internal weld. Integrity of these joints will be monitored by periodic system pressure and hydrostatic tests.

III. ALTERNATE PROVISIONS

An alternative surface examination of the reinforcing ring welds will be performed and a visual examination for evidence of leakage will be conducted in accordance with the Subsection IWC-5000 requirements.

Station's procedure will be revised to insure the performance of the alternative examinations.

RELIEF REQUEST NO. CR-9

I. IDENTIFICATION OF COMPONENTS AND IMPRACTICAL CODE REQUIREMENTS

Quad Cities Station currently utilizes a calibration block which lacks documentation consistent with the requirements of current editions of the Code. The documentation requirements existing at the time of their fabrication did not require traceability to the material's chemical or physical certifications. As a result, the only documentation available for the existing blocks is verification of the appropriate P-number grouping.

The Section XI requirements of the 1980 Edition of the ASME Code including the Winter 1980 Addenda specify that the block will be fabricated as provided by Article III-3400, paragraph III-3411 requirements.

Relief is requested from this documentation requirements to allow the continued use of the existing calibration blocks.

II. BASIS FOR RELIEF

Previous inservice inspections have been performed utilizing the above mentioned block and its use would provide continuity in the ISI Program. It would be impractical to fabricate a new

calibration block in order to satisfy the documentation requirements of the current Code. Existing records which indicate the appropriate material P-grouping provide adequate assurance that the block will establish the proper ultrasonic calibration and sensitivity. Additionally, since both reactors vessels are 100% clad on the I.D. surface, there is no way to meet the requirement of verifying the acoustic properties of the block against the clad component.

III. ALTERNATE PROVISIONS

The present reactor vessel calibration block will be demonstrated to have acoustic attenuation and velocity properties which fall within the range of straight beam longitudinal wave velocity and attenuation as found in the reactor vessel. However, since Quad-Cities Station reactor vessels are 100% clad on the I.D. Surface, this check will be completed on the clad component and appropriate reviews made by the C.E.C.O. Level III Examiner to verify the acceptability of the block.

RELIEF REQUEST NO. CR-10

I. IDENTIFICATION OF COMPONENTS AND IMPRACTICAL CODE
REQUIREMENT

The design of certain Class-2 branch pipe connection welds calls for the use of reinforcement saddles. These saddles are fillet welded over the actual pressure retaining branch pipe to main pipe weld, completely encasing it as illustrated on Figure 3. As listed in the program, there are 40 such welds that are greater than 4 inches in diameter.

Section XI of the ASME Boiler and Pressure Vessel Code, 1980 Edition through the Winter 1980 Addenda requires that branch pipe connection welds exceeding 4 inches diameter be surface examined. (Code Category C.F)

Relief from this requirement is requested due to the physical inaccessibility of the design.

II. BASIS FOR RELIEF

The fabrication of these joints precludes any type of surface examination. Additional assurance of the continued integrity of joints fabricated in this fashion is afforded by the fact that

the reinforcement saddle strengthens the joint and reduces the stresses on the internal weld.

III. ALTERNATE PROVISIONS

Surface examination of the saddle fillet welds will be performed in lieu of the Code required examination, and a visual examination of these joints for evidence of leakage will be conducted during the pressure tests required by IWC-5000.

Station's procedure will be revised to ensure the performance of the alternative surface examination.

RELIEF REQUEST NO. CR-11

I. IDENTIFICATION OF COMPONENTS AND IMPRACTICAL CODE REQUIREMENT

Section XI of the 1980 Edition of the ASME Code including the Winter 1980 Addenda specifies that a volumetric inspection of all full penetration nozzle inside radii sections (code category B-D, item B3.100) each ten-year interval.

The design of the Standby Liquid Control (SBLC) Nozzle as shown on Figure 6 provides an inner radius geometry which is not conducive to ultrasonic inspection.

Relief is requested from this SBLC inner radius inspection due to the nozzle inside radius geometry.

II. BASIS FOR RELIEF

The design of the SBLC nozzle piece does not lend itself to ultrasonic inspection. The nozzle as shown on figure 6 has an integral socket to which the boron injection piping is fillet welded and consequently provides a geometry which will result in a meaningless ultrasonic examination.

III. ALTERNATE PROVISION

No alternate or augmented examinations are feasible at this time.

RELIEF REQUEST NO. CR-12

I. IDENTIFICATION OF COMPONENTS AND IMPRACTICAL CODE REQUIREMENTS

Each Quad-Cities Unit has an ISI class 2 HPCI Turbine in the HPCI System.

The ASME Boiler and Pressure Vessel Code, Section XI 1980 Edition through the Winter 1980 Addenda requires a hydrostatic test once every inspection interval on all ISI class 2 pressure boundaries.

Relief is requested from this Code requirements in order to avoid damaging the turbine's labyrinth seals.

II. BASIS FOR RELIEF

The labyrinth seals used in the HPCI turbine are designed to prevent steam from leaking out of the turbine casing. The fragile design of the seals is not intended to retain water under pressure. Therefore, performing a hydrostatic test on the turbine casing will permanently damage the turbine seals.

III. ALTERNATE PROVISIONS

A system functional test will be conducted in lieu of the hydrostatic test.

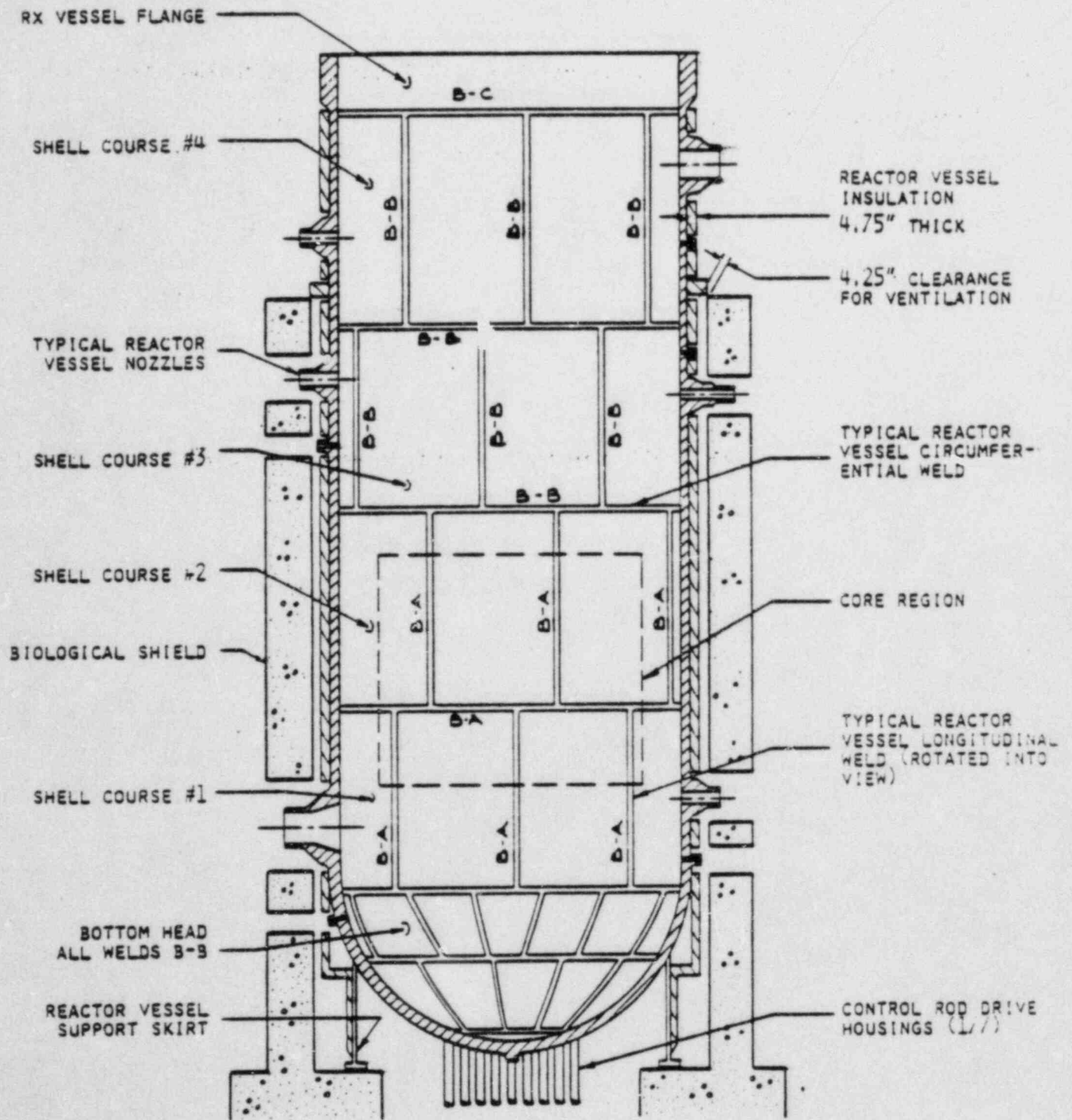

FIGURE 1.a
 REACTOR VESSEL WELD IDENTIFICATION

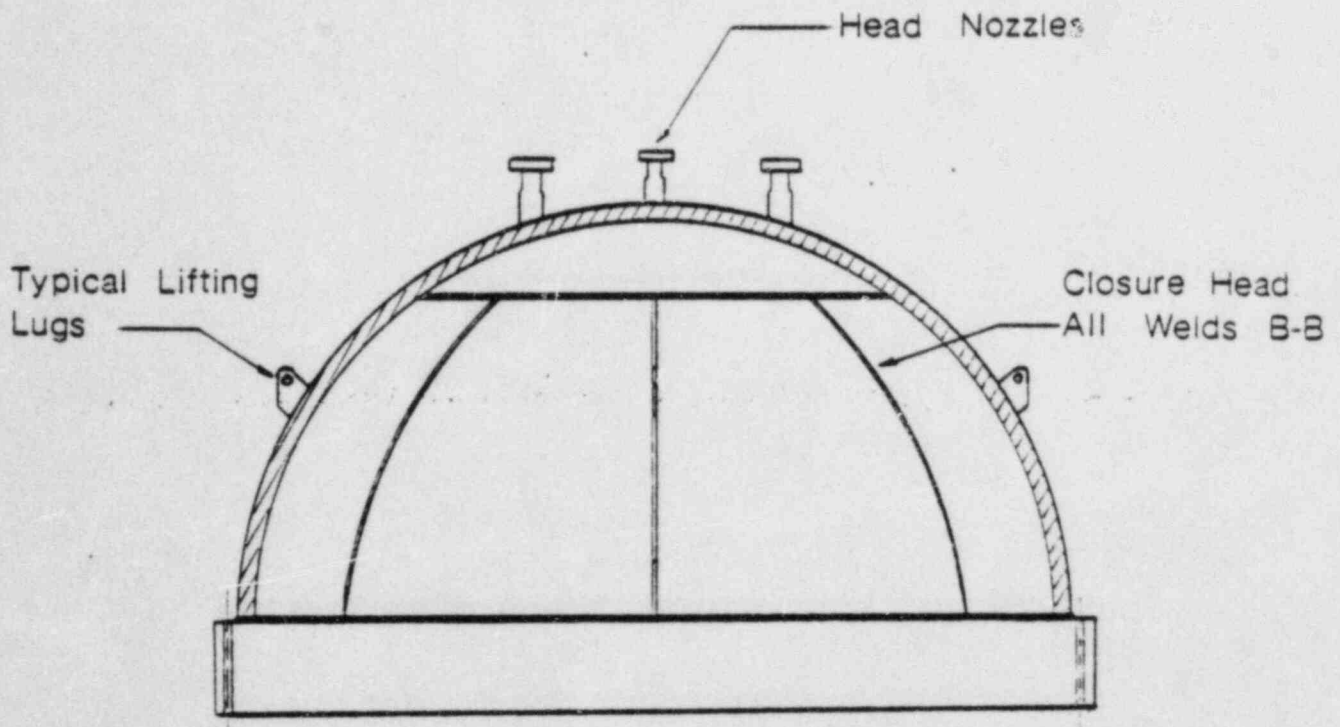

FIGURE 1.b
Reactor Closure Head Weld Identification

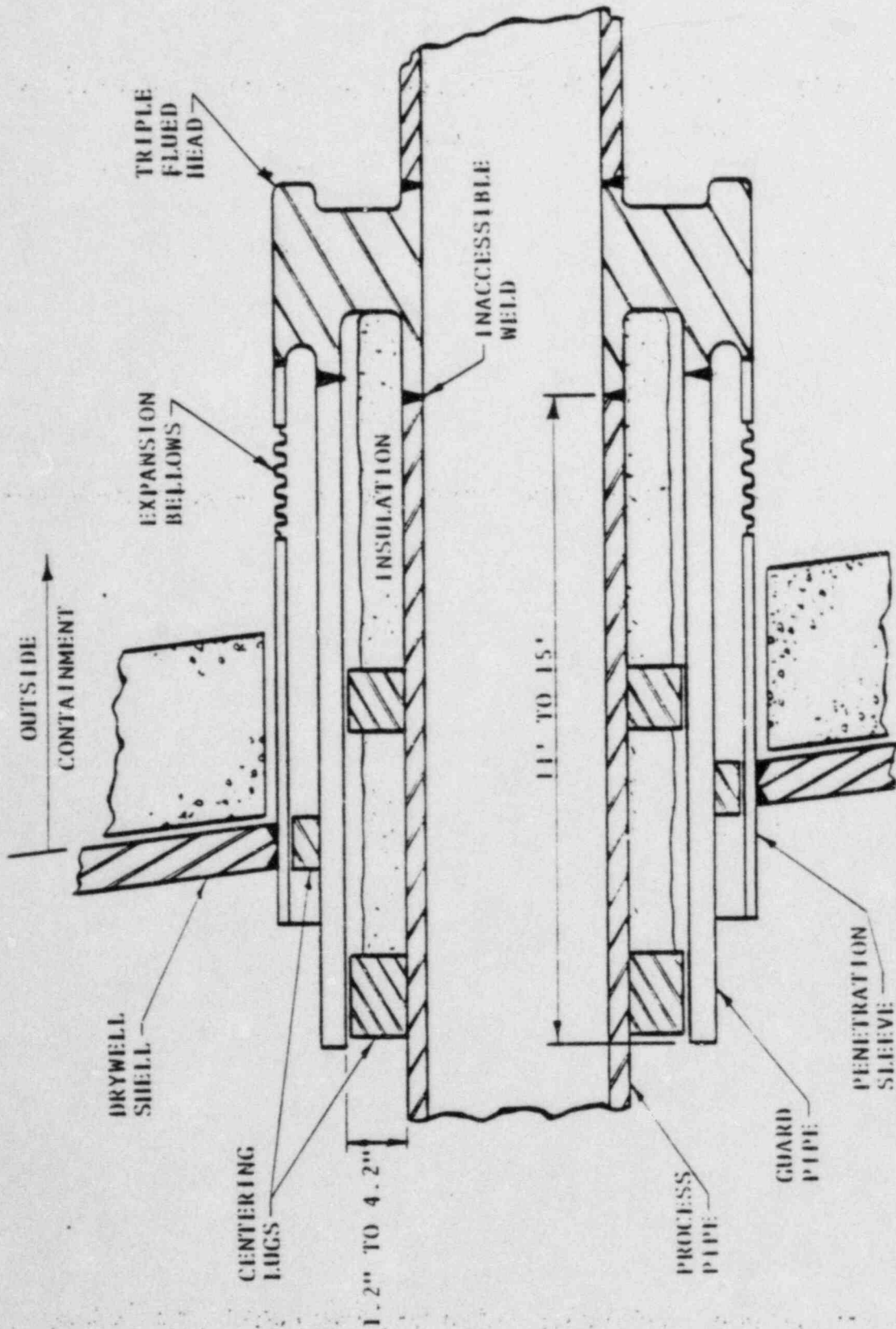

FIGURE 2
 TYPICAL DESIGN OF PRIMARY CONTAINMENT PENETRATION

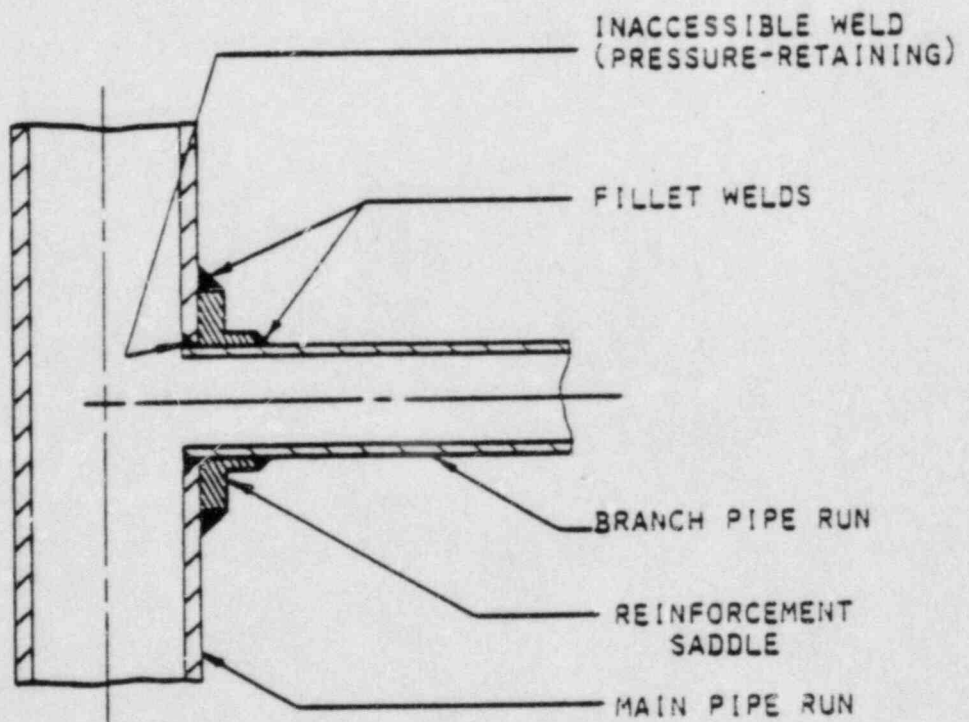
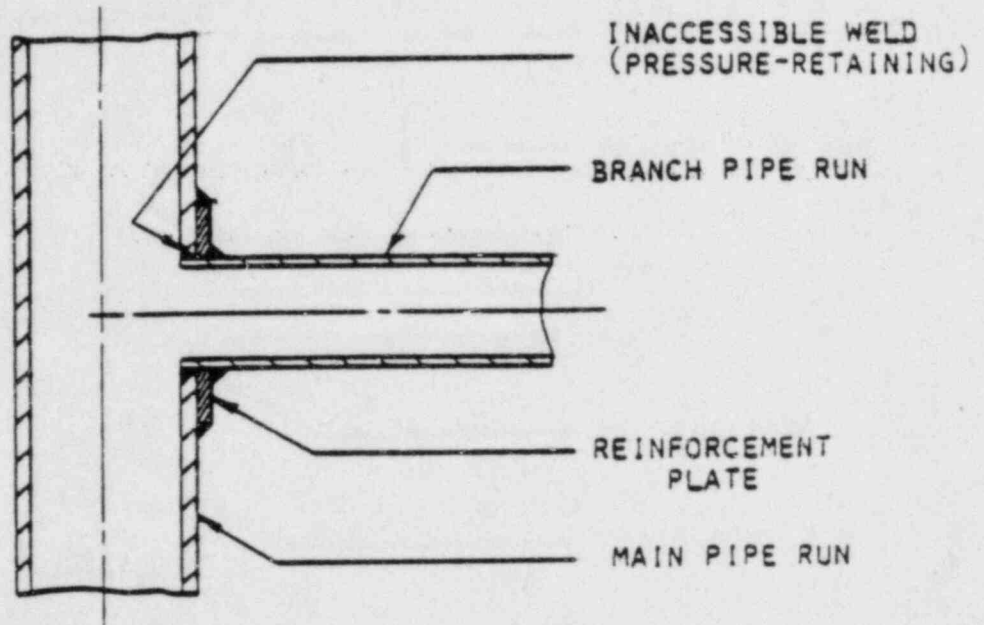

FIGURE 3

TYPES OF REINFORCED BRANCH PIPE CONNECTIONS

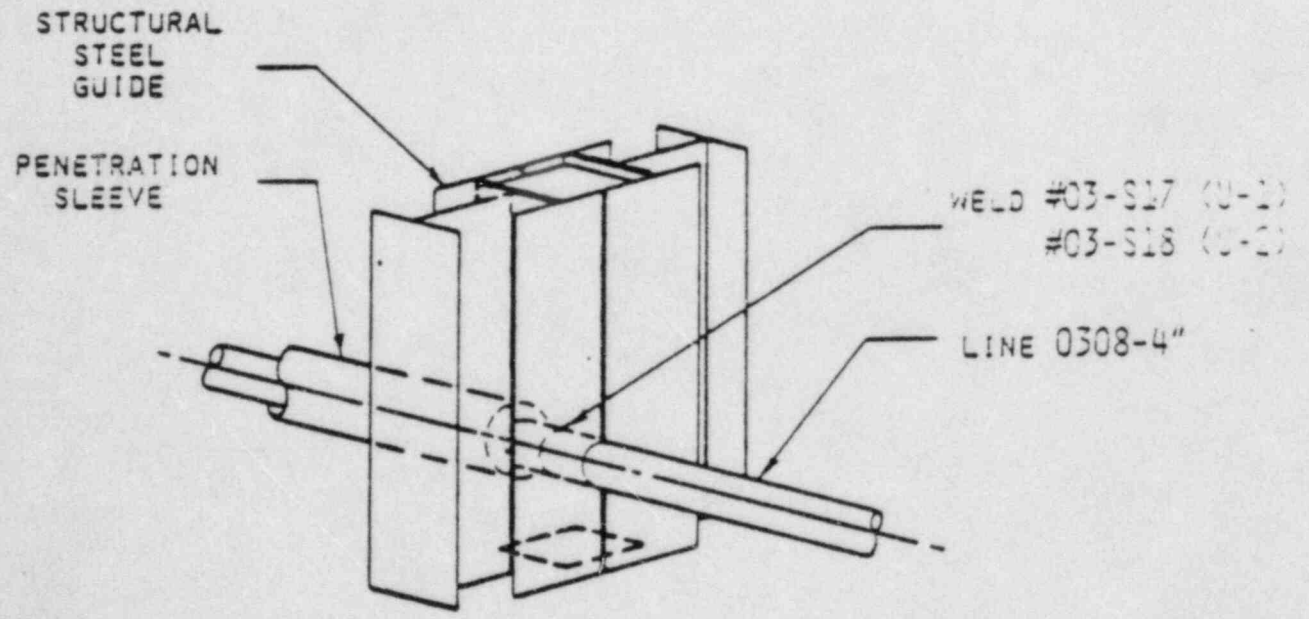
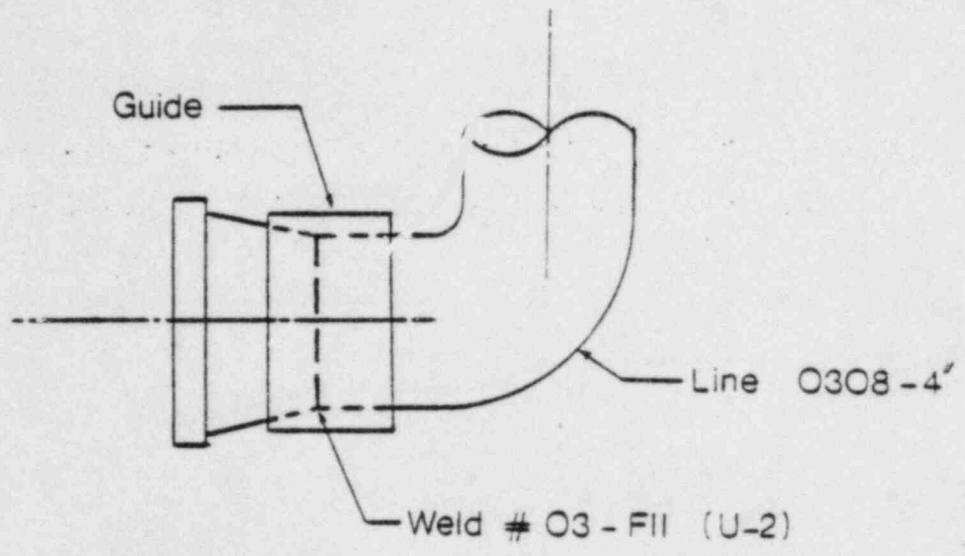

FIGURE 4
WELD OBSTRUCTION DETAILS

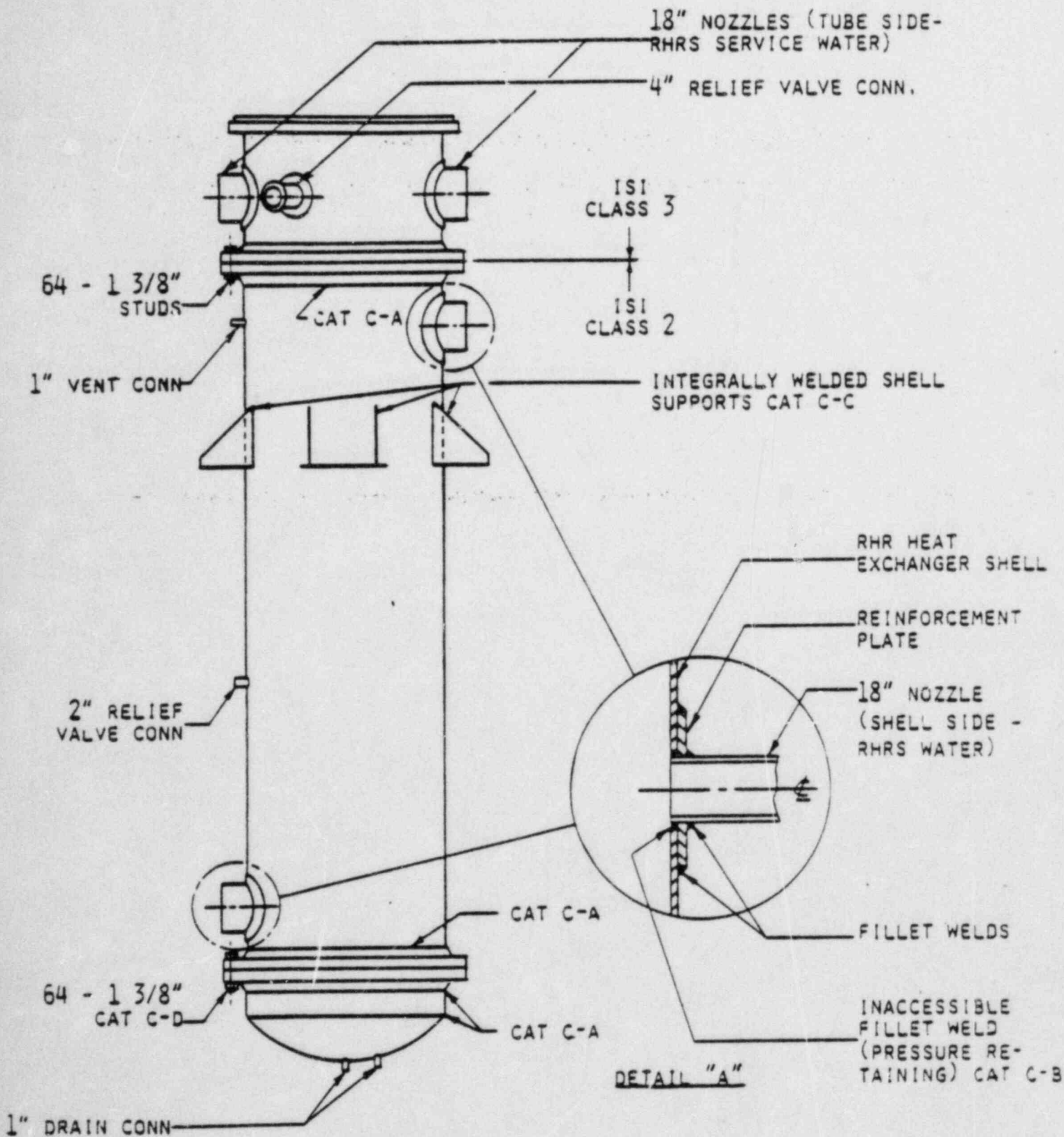
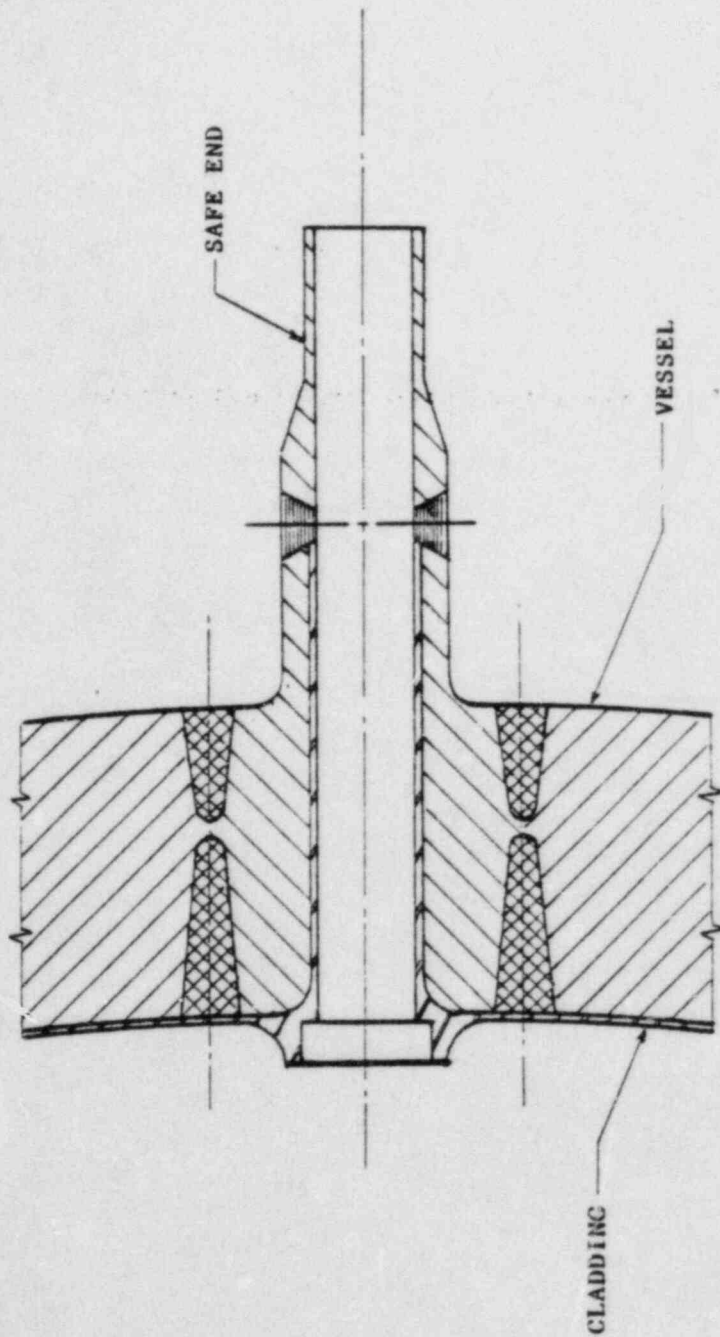

FIGURE 5
RHR HEAT EXCHANGERS

Figure 6

Standby Liquid Control Nozzle



3.0 INSERVICE TESTING PROGRAM FOR SNUBBERS

3.1 GENERAL INFORMATION

The Inservice Testing Program for snubbers meets the requirements of subsection IWF, of Section XI of the ASME Boiler and Pressure Vessel Code, 1980 Edition through the Winter 1980 Addenda. Where the requirements are determined to be impractical, specific requests for relief have been written.

The IST Program for snubbers is presented in Section 3.2 in a tabular format. The snubbers are listed without Code category as there is no category assigned by Section XI of the ASME Code. The information given in the tables is explained below.

- A. ISI Support No. - lists the number assigned to the support assembly which belongs to ISI class 1, 2 and 3 (i.e. structural attachments and snubbers).
- B. Tech Spec Snubber No. - lists the unique number assigned to the snubber.

- C. Snubber Type - identifies the snubber type (i.e. M = mechanical, H = hydraulic)

- D. System - gives the system abbreviation (see tables 3.2-1) of this program for explanation of abbreviations.

- E. Test Parameters - lists the appropriate test to be performed on snubbers. These tests are referenced to the appropriate paragraph within IWF-5400.

- F. Remarks - gives general clarification remarks.

Tables 3.2-1 list the systems and their respective P&ID numbers which are covered in the Snubber Testing Program.

There are no relief requests applicable to the Snubber Testing Program.

SECTION 3.2

TABLES FOR INSERVICE TESTING PROGRAM FOR SNUBBERS

A. QUAD CITIES UNIT-1

B. QUAD CITIES UNIT-2

TABLE 3.2-1a

LIST OF SYSTEMS INCLUDED IN THE SNUBBER PROGRAM FOR UNIT-1

<u>SYSTEM</u>	<u>SYSTEM NUMBER</u>	<u>REFERENCE P&ID</u>
Recirculation (Recirc.)	0200	35-2
Control Rod Drive (C.R.D.)	0300	41
Residual Heat Removal (RHRS)	1000	37 & 39
Core Spray	1400	36
Main Steam	3000	13-1 & 2
High Pressure Coolant Injection (HPCI)	2300	46
Diesel Generator cooling Water (DGCW)	3900	22-1



Commonwealth
Edison

IN SERVICE TESTING PROGRAM

SNUBBER TESTING (IWF-5000)
QUAD CITIES NUCLEAR POWER STATION

UNIT - 1

Page 1 of 4
Revision 2 Date 9-17-84

SUPPORT NUMBER	SNUBBER NO.	SNUBBER TYPE	SYSTEM	TEST PARAMETERS			REMARKS
				(1)	(2)	(3)	
1404-W-103	1-1	H	Core Spray	X	X		
1404-W-103	1-2	M	Core Spray	X	X		
1403-W-103	1-3	M	Core Spray	X	X		
1403-W-103	1-4	M	Core Spray	X	X		
1012A-W-101	1-5	M	RHRS	X	X		
1012A-W-102	1-6	M	RHRS	X	X		
1012B-W-102	1-7	M	RHRS	X	X		
1012B-W-101	1-8	M	RHRS	X	X		
0200-W-109	1-11	H	Recirc (1A-202 PMP)	X	X		
0200-W-127	1-12	H	Recirc (1B-202 PMP)	X	X		
0200-W-107	1-13	M	Recirc (1A-202 PMP)	X	X		
0200-W-129	1-14	M	Recirc (1B-202 PMP)	X	X		
0200-W-128	1-15	M	Recirc (1B-202 PMP)	X	X		
0200-W-154	1-16	M	Recirc Ring Header	X	X		
0200-W-143	1-17	M	Recirc Ring Header	X	X		
0200-M-110	1-18	M	Recirc (1A-202 Motor)	X	X		
0200-M-130	1-19	M	Recirc (1B-202 Motor)	X	X		
0200-W-169	1-20	M	Recirc	X	X		
0200-W-108	1-21	M	Recirc (1A-202 PMP)	X	X		

NOTES: (1) Test as required by IWF 5400(b)(1)
 (2) Test as required by IWF 5400(b)(2)
 (3) Test as required by IWF 5400(b)(3)



Commonwealth
Edison

INSERVICE TESTING PROGRAM

SNUBBER TESTING (IWF-5000)
QUAD CITY NUCLEAR POWER STATION

UNIT - 1

Page 2 of 4
Revision 2 Date 9-17-84

ISI SUPPORT NUMBER	SNUBBER NO.	SNUBBER TYPE	SYSTEM	TEST PARAMETERS			REMARKS
				(1)	(2)	(3)	
Q200-M-111	1-22	M	Recirc (1A-202 Motor)	X	X		
Q200-M-112	1-23	M	Recirc (1A-202 Motor)	X	X		
Q200-M-131	1-24	M	Recirc (1B-202 Motor)	X	X		
Q200-M-132	1-25	M	Recirc (1B-202 Motor)	X	X		
3Q35A-M-101	1-28	M	Main steam (SRV disch)	X	X		
1Q15A-W-202	1-95	M	RIIRS	X	X		
1Q15A-W-203	1-96	M	RIIRS	X	X		
Q200-M-171	1-43	M	Recirc	X	X		
Q200-M-172	1-44	M	Recirc	X	X		
Q200-M-175	1-45	M	Recirc	X	X		
Q200-M-174	1-46	M	Recirc	X	X		
Q200-M-173	1-47	M	Recirc	X	X		
Q200-M-170	1-48	M	Recirc	X	X		
1Q11-M-111	1-49	M	RIIRS/Head Spray	X	X		
3Q01A-M-101.2	1-58	M	Main Steam	X	X		
3Q01B-M-101.1	1-63	M	Main Steam	X	X		

NOTES: (1) Test as required by IWF 5400(b)(1)
 (2) Test as required by IWF 5400(b)(2)
 (3) Test as required by IWF 5400(b)(3)



INSERVICE TESTING PROGRAM

SNUBBER TESTING (IMF-5000)
 QUAD CIRC NUCLEAR POWER STATION

UNIT - 1

Page 3 of 4
 Revision 2 Date 9-17-84

ISH SUPPORT NUMBER	SNUBBER NO.	SNUBBER TYPE	SYSTEM	TEST PARAMETERS			REMARKS
				(1)	(2)	(3)	
3001B-M-101.2	1-64	M	Main Steam	X	X		
2305-M-101.1	1-67	M	HPCI	X	X		
2305-M-101.2	1-68	M	HPCI	X	X		
3001C-M-101.1	1-69	M	Main Steam	X	X		
3001C-M-101.2	1-70	M	Main Steam	X	X		
3001C-M-102.1	1-71	M	Main Steam	X	X		
3001D-M-101.1	1-74	M	Main Steam	X	X		
3001D-M-101.2	1-75	M	Main Steam	X	X		
3001D-M-102.1	1-76	M	Main Steam	X	X		
1015A-W-201	1-94	M	RHRS	X	X		
1015A-M-204	1-97	M	RHRS	X	X		
1015A-M-205	1-98	M	RHRS	X	X		
1015A-M-206	1-99	M	RHRS	X	X		
1015A-M-206	1-100	M	RHRS	X	X		
1015B-M-202	1-102	M	RHRS	X	X		
1015B-M-203	1-103	M	RHRS	X	X		
1016D-M-201.1	1-104	M	RHRS	X	X		
1012B-M-203.1	1-110	M	RHRS	X	X		
2306-W-207	1-111	M	HPCI	X	X		

NOTES: (1) Test as required by IMF 5400(b)(1)
 (2) Test as required by IMF 5400(b)(2)
 (3) Test as required by IMF 5400(b)(3)



Commonwealth
Edison

INSERVICE TESTING PROGRAM

SNUBBER TESTING (IWF-5000)
QUAD CITY'S NUCLEAR POWER STATION

UNIT - 1

Page 4 of 4
Revision 2 Date 9-17-84

ISI SUPPORT NUMBER	SNUBBER NO.	SNUBBER TYPE	SYSTEM	TEST PARAMETERS			REMARKS
				(1)	(2)	(3)	
2306-M-205.1	1-112	M	HPCI	X	X		
2306-M-203.3	1-113	M	HPCI	X	X		
2306-M-203.2	1-114	M	HPCI	X	X		
2306-M-203.1	1-115	M	HPCI	X	X		
1025-M-101	1-122	M	RHRS	X	X		
1025-M-101	1-123	M	RHRS	X	X		
1025-M-103	1-124	M	RHRS	X	X		
1025-M-103	1-125	M	RHRS	X	X		
3950-M-313.1	1-126	M	DGCW	X	X		
0328-M-202	1-128	M	CRD (SDV)	X	X		
0320-M-202	1-129	M	CRD (SDV)	X	X		

NOTES: (1) Test as required by IWF 5400(b)(1)
 (2) Test as required by IWF 5400(b)(2)
 (3) Test as required by IWF 5400(b)(3)

TABLE 3.2.1b

LIST OF SYSTEMS INCLUDED IN THE SNUBBER PROGRAM FOR UNIT-2

<u>SYSTEM</u>	<u>SYSTEM</u> <u>NUMBER</u>	<u>REFERENCE</u> <u>P&ID</u>
Recirculation (Recirc.)	0200	77-2
Control Rod Drive (C.R.D.)	0300	83
Residual Heat Removal (RHRS)	1000	79 & 81
Reactor Cleanup (RWCU)	1200	88
Reactor Core Isolation Cooling (RCIC)	1300	89
Core Spray	1400	78
High Pressure Coolant Injection (HPCI)	2300	87
Main Steam	3000	60-1 & 2



Commonwealth
Edison

INSERVICE TESTING PROGRAM

SNUBBER TESTING (IWF 5000)
QUAD CIRC NUCLEAR POWER STATION

UNIT - 2

Page 1 of 4
Revision 2 Date 9-17-84

ISI SUPPORT NUMBER	SNUBBER NO	SNUBBER TYPE	SYSTEM	TEST PARAMETERS			REMARKS
				(1)	(2)	(3)	
1404-W-103	2-1	M	Core Spray	X	X		
1404-W-103	2-2	M	Core Spray	X	X		
1403-W-103	2-3	M	Core Spray	X	X		
1403-W-103	2-4	M	Core Spray	X	X		
1012A-W-101	2-5	M	RHRS	X	X		
1012A-W-102	2-6	M	RHRS	X	X		
1012B-W-102	2-7	M	RHRS	X	X		
1012B-W-101	2-8	M	RHRS	X	X		
0200-W-107	2-11	M	Recirc (2A-202 PMP)	X	X		
0200-W-127	2-12	M	Recirc (2B-202 PMP)	X	X		
0200-W-109	2-13	M	Recirc (2A-202 PMP)	X	X		
0200-W-128	2-14	M	Recirc (2B-202 PMP)	X	X		
0200-W-129	2-15	M	Recirc (2B-202 PMP)	X	X		
0200-W-154	2-16	M	Recirc Ring Header	X	X		
0200-W-143	2-17	M	Recirc Ring Header	X	X		
0200-M-110	2-18	M	Recirc	X	X		
0200-M-130	2-19	M	Recirc	X	X		
0200-W-108	2-21	M	Recirc (2A-202 PMP)	X	X		
0200-M-111	2-22	M	Recirc (2A-202 Motor)	X	X		
0200-M-112	2-23	M	Recirc (2A-202 Motor)	X	X		

NOTES: (1) Test as required by IWF 5400(b)(1)
(2) Test as required by IWF 5400(b)(2)
(3) Test as required by IWF 5400(b)(3)



Commonwealth
Edison

INSERVICE TESTING PROGRAM

SHUBERT TESTING (WF 54000)
GRAND CREEK NUCLEAR POWER STATION

UNIT - 2

Page 2 of 4
Revision 3 Date 9-17-84

ISI SUPPORT NUMBER	SMUBBER NO	SMUBBER TYPE	SYSTEM	TEST PARAMETERS		REMARKS
				(1)	(2)	
0200-M-131	2-24	M	Recirc (2B-202 Motor)	X	X	
0200-M-132	2-25	M	Recirc (2B-202 Motor)	X	X	
3001A-M-105	2-28	M	Main Steam	X	X	
1307-M-106	2-42	M	RCIC	X	X	
3001A-M-101.1	2-54	M	Main Steam	X	X	
3001A-M-101.2	2-55	M	Main Steam	X	X	
3001A-M-102.3	2-56	M	Main Steam	X	X	
3001B-M-101.1	2-61	M	Main Steam	X	X	
3001B-M-103.1	2-62	M	Main Steam	X	X	
3001C-M-101.2	2-66	M	Main Steam	X	X	
3001C-M-101.1	2-67	M	Main Steam	X	X	
3001C-M-103.1	2-68	M	Main Steam	X	X	
3001D-M-101.1	2-71	M	Main Steam	X	X	
3001D-M-101.2	2-72	M	Main Steam	X	X	
3001D-M-102.1	2-73	M	Main Steam	X	X	
2305-M-101.2	2-76	M	HPCL	X	X	
2305-M-101.1	2-77	M	HPCL	X	X	
2305-M-102.1	2-78	M	HPCL	X	X	
0200-M-171	2-79	M	Recirc	X	X	
0200-M-158.1	2-80	M	Recirc	X	X	

NOTES: (1) Test as required by IMF 5400(b)(1)
(2) Test as required by IMF 5400(b)(2)
(3) Test as required by IMF 5400(b)(3)



Commonwealth
Edison

INSERVICE TESTING PROGRAM

SNUBBER TESTING (IWF 5400)
QUAD CITIES NUCLEAR POWER STATION

UNIT - 2

Page 3 of 4
Revision 2 Date 9-17-84

ISI SUPPORT NUMBER	SNUBBER NO	SNUBBER TYPE	SYSTEM	TEST PARAMETERS			REMARKS
				(1)	(2)	(3)	
0200-M-170	2-81	M	Recirc	X	X		
0200-M-169	2-82	M	Recirc	X	X		
1025-M-102.1	2-83	M	RIIRS/SDC	X	X		
1025-M-102.1	2-84	M	RIIRS/SDC	X	X		
1025-M-101	2-85	M	RIIRS/SDC	X	X		
1025-M-101	2-86	M	RIIRS/SDC	X	X		
1202-M-115	2-87	M	RHCU	X	X		
1202-M-115	2-88	M	RWCU	X	X		
3001B-M-101.2	2-89	M	Main Steam	X	X		
1404-M-206.1	2-113	M	Core Spray	X	X		
2306-M-206.1	2-114	M	HPCI	X	X		
2306-M-205.2	2-115	M	HPCI	X	X		
2305-M-211.2	2-120	M	HPCI	X	X		
2302-M-202.1	2-121	M	HPCI	X	X		
1016A-M-202	2-122	M	RIIRS	X	X		
1016A-M-203	2-123	M	RIIRS	X	X		
1015A-M-202	2-124	M	RIIRS	X	X		
1015A-M-203	2-125	M	RIIRS	X	X		
1015B-M-203	2-126	M	RIIRS	X	X		
1015B-M-204	2-127	M	RIIRS	X	X		

NOTES: (1) Test as required by IWF 5400(b)(1)
(2) Test as required by IWF 5400(b)(2)
(3) Test as required by IWF 5400(b)(3)



Commonwealth
Edison

INSERVICE TESTING PROGRAM

SNUBBER TESTING (IWF 5000)
QUAD CHES NUCLEAR POWER STATION

UNIT - 2

Page 4 of 4
Revision 2 Date 9-17-84

ISI SUPPORT NUMBER	SNUBBER NO.	SNUBBER TYPE	SYSTEM	TEST PARAMETERS			REMARKS
				(1)	(2)	(3)	
1015B-M-201	2-128	M	RHRS	X	X		
1012A-M-203.1	2-129	M	RHRS	X	X		
1404-M-207.1	2-130	M	Core Spray	X	X		
1404-M-207.2	2-131	M	Core Spray	X	X		
2306-W-207	2-132	M	HPCT	X	X		
2306-M-205.1	2-133	M	HPCT	X	X		
1043B-M-301.1	2-138	M	RHRWS	X	X		

NOTES: (1) Test as required by IWF 5400(b)(1)
(2) Test as required by IWF 5400(b)(2)
(3) Test as required by IWF 5400(b)(3)

4.0 INSERVICE TESTING PROGRAM FOR PUMPS

4.1 GENERAL INFORMATION

The Inservice Testing Program for ISI Class 1, 2 and 3 pumps meets the requirements of Subsection IWP of Section XI of the ASME Boiler and Pressure Vessel Code, 1980 Edition through the Winter 1980 Addenda. Where these requirements are determined to be impractical, specific requests for relief have been written.

The tables in Section 4.2 list all Class 1, 2 and 3 pumps which are within the scope of IWP-1100 to be tested along with the parameters to be measured for each pump unless reference is made to a relief request. Section 4.3 includes all relief requests referenced in the tables plus any additional relief requests that are generic to the pump testing program. Table 4.2-1 lists the systems and their respective P&ID numbers which are covered in the pump testing program.

It should be noted that pump speed is not measured for synchronous type pumps per IWP-4400. Where pump suction is from a tank or the river, inlet pressure will be calculated from the measured tank or river level.

SECTION 4.2

TABLES FOR INSERVICE PUMP TESTING PROGRAM

A. QUAD CITIES UNIT-1

B. QUAD CITIES UNIT-2

TABLE 4.2.1a

LIST OF SYSTEMS INCLUDED IN THE PUMP PROGRAM FOR UNIT-1

<u>SYSTEM</u>	<u>SYSTEM</u> <u>NUMBER</u>	<u>REFERENCE</u> <u>P&ID</u>
Core Spray	1400	36
Residual Heat Removal	1000	37 & 39
Residual Heat Removal Service Water	1000	37 & 39
Standby Liquid Control	1100	40
High Pressure Coolant Injection	2300	46
Diesel Generator Cooling Water	3900	22
Diesel Generator Fuel Oil Transfer	5200	29



Commonwealth
Edison

INSERVICE TESTING PROGRAM

ISI-CLASS 1, 2, & 3 PUMPS
QUAD CITIES NUCLEAR POWER STATION

UNIT - 1

REVISION	-	DATE	PAGE
3		9-17-84	1 of 1

PUMP NUMBER	PUMP NAME	CLASS	P & ID AND COORDINATES	TEST PARAMETERS						TEST INTERVAL
				SPEED	INLET PRES	DIFF PRES	FLOW RATE	VIBRATION	BEARING TEMP	
1A-1401	CORE SPRAY	2	36 E-9	NO	YES	YES	YES	PR-1	PR-1	QUARTERLY
1B-1401	CORE SPRAY	2	36 E-6	NO	YES	YES	YES	PR-1	PR-1	QUARTERLY
1A-1002	RESIDUAL HEAT REMOVAL	2	37 B-4	NO	YES	YES	YES	PR-1	PR-1	QUARTERLY
1B-1002	RESIDUAL HEAT REMOVAL	2	37 E-4	NO	YES	YES	YES	PR-1	PR-1	QUARTERLY
1C-1002	RESIDUAL HEAT REMOVAL	2	37 B-8	NO	YES	YES	YES	PR-1	PR-1	QUARTERLY
1D-1002	RESIDUAL HEAT REMOVAL	2	37 E-8	NO	YES	YES	YES	PR-1	PR-1	QUARTERLY
1-1001-65A	RHR SERVICE WATER	3	39 F-4	NO	YES	YES	YES	PR-1	PR-1	QUARTERLY
1-1001-65B	RHR SERVICE WATER	3	39 F-4	NO	YES	YES	YES	PR-1	PR-1	QUARTERLY
1-1001-65C	RHR SERVICE WATER	3	39 F-7	NO	YES	YES	YES	PR-1	PR-1	QUARTERLY
1-1001-65D	RHR SERVICE WATER	3	39 F-7	NO	YES	YES	YES	PR-1	PR-1	QUARTERLY
1A-1102	STANDBY LIQUID CONTROL	2	40 D-7	NO	PR-3	PR-3	YES	PR-1	PR-1	QUARTERLY
1B-1102	STANDBY LIQUID CONTROL	2	40 E-7	NO	PR-3	PR-3	YES	PR-1	PR-1	QUARTERLY
1-2302	HIGH PRES COOLANT INJ	2	46 A-4	YES	YES	YES	YES	PR-1	PR-1	QUARTERLY
1-3903	D/G COOLING WATER	3	22 A-10	NO	YES	YES	YES	PR-1	PR-1	QUARTERLY
1/2-3903	D/G COOLING WATER	3	22 A-10	NO	YES	YES	YES	PR-1	PR-1	QUARTERLY
1-5203	D/G FUEL OIL TRANSFER	NC	29 F-3	NO	PR-4	PR-4	YES	PR-1	PR-1	QUARTERLY
1/2-5203	D/G FUEL OIL TRANSFER	NC	29 F-3	NO	PR-4	PR-4	YES	PR-1	PR-1	QUARTERLY

NOTE: Lubrication levels will be observed during each inservice test for pumps that are designed such that levels can be verified. The core spray(1401), RHR (1002), and the D/G fuel oil transfer (5203) pumps are lubricated by pump flowage and, thus, lubricant level or pressure measurements are not relevant.

TABLE 4.2.1b

LIST OF SYSTEMS INCLUDED IN THE PUMP PROGRAM FOR UNIT-2

<u>SYSTEM</u>	<u>SYSTEM NUMBER</u>	<u>REFERENCE P&ID</u>
Core Spray	1400	78
Residual Heat Removal	1000	79 & 81
Residual Heat Removal Service Water	1000	79 & 81
Standby Liquid Control	1100	82
High Pressure Coolant Injection	2300	87
Diesel Generator Cooling Water	3900	69
Diesel Generator Fuel Oil Transfer	5200	29



Commonwealth
Edison

INSERVICE TESTING PROGRAM

ISI-CLASS 1, 2, & 3 PUMPS
QUAD CITIES NUCLEAR POWER STATION

UNIT - 2

REVISION - DATE
2 9/17/84

PAGE
1 of 1

PUMP NUMBER	PUMP NAME	CLASS	P & ID AND COORDINATES	TEST PARAMETERS						TEST INTERVAL
				SPEED	INLET PRES	DIFF PRES	FLOW RATE	VIBRATION	BEARING TEMP	
2A-1401	CORE SPRAY	2	78 E-9	NO	YES	YES	YES	FR-1	PR-1	QUARTERLY
2B-1401	CORE SPRAY	2	78 E-9	NO	YES	YES	YES	PR-1	PR-1	QUARTERLY
2A-1002	RESIDUAL HEAT REMOVAL	2	79 B-4	NO	YES	YES	YES	PR-1	PR-1	QUARTERLY
2B-1002	RESIDUAL HEAT REMOVAL	2	79 E-4	NO	YES	YES	YES	PR-1	PR-1	QUARTERLY
2C-1002	RESIDUAL HEAT REMOVAL	2	79 B-9	NO	YES	YES	YES	PR-1	PR-1	QUARTERLY
2D-1002	RESIDUAL HEAT REMOVAL	2	79 E-9	NO	YES	YES	YES	PR-1	PR-1	QUARTERLY
2-1001-65A	RHR SERVICE WATER	3	81 F-4	NO	YES	YES	YES	PR-1	PR-1	QUARTERLY
2-1001-65B	RHR SERVICE WATER	3	81 F-4	NO	YES	YES	YES	PR-1	PR-1	QUARTERLY
2-1001-65C	RHR SERVICE WATER	3	81 F-7	NO	YES	YES	YES	PR-1	PR-1	QUARTERLY
2-1001-65D	RHR SERVICE WATER	3	81 F-7	NO	YES	YES	YES	PR-1	PR-1	QUARTERLY
2A-1102	STANDBY LIQUID CONTROL	2	82 D-7	NO	PR-3	PR-3	YES	PR-1	PR-1	QUARTERLY
2B-1102	STANDBY LIQUID CONTROL	2	82 E-7	NO	PR-3	PR-3	YES	PR-1	PR-1	QUARTERLY
2-2302	HIGH PRES COOLANT INJ	2	87 A-4	YES	YES	YES	YES	PR-1	PR-1	QUARTERLY
2-3903	D/G COOLING WATER	3	69 A-10	NO	YES	YES	YES	PR-1	PR-1	QUARTERLY
2-5203	D/G FUEL OIL TRANSFER	NC	29 F-3	NO	PR-4	PR-4	YES	PR-1	PR-1	QUARTERLY

NOTE: Lubrication levels will be observed during each inservice test for pumps that are designed such that levels can be verified. The core spray(1401), RHR (1002), and the D/G fuel oil transfer (5203) pumps are lubricated by pump flowage and, thus, lubricant level or pressure measurements are not relevant.

SECTION 4.3

RELIEF REQUESTS FOR INSERVICE PUMP TESTING PROGRAM

RELIEF REQUEST NO. PR-1

PUMP NUMBER: All pumps in program.

SECTION XI REQUIREMENT: IWP-1500, Detection of Change.

BASIS FOR RELIEF: Pump vibration and bearing temperature are required to be measured to detect any changes in the mechanical characteristics of a pump. This is to detect developing problems so repairs can be initiated prior to a pump becoming inoperable (i.e. unable to perform its function). The ASME Code minimum standards require measurement of the vibration amplitude displacement in mils (thousands of an inch) every three months and bearing temperatures once per year.

Quad Cities Station proposes an alternate program which is believed to be more comprehensive than that required by Section XI. This program consists of performing the required vibration readings in velocity rather than mils displacement. This technique is an industry-accepted method which is much more meaningful and sensitive to small changes that are indicative of developing mechanical problems. These velocity measurements detect not only high amplitude vibrations that indicate a major mechanical problem but also the equally harmful low

RELIEF REQUEST NO. PR-1 (CONTINUED)

amplitude - high frequency vibrations due to misalignment, imbalance, or bearing wear that usually go undetected by simple displacement measurements.

In addition, these readings go far beyond the capabilities of a bearing temperature monitoring program, which requires a bearing to be seriously degraded prior to the detection of increased heat at the bearing housing. The vibration velocity readings on a schedule of once every three months achieves a much higher probability of detecting developing problems than the once per year reading of bearing temperatures. Data gathering on bearing temperatures also is not without its own problems. The enforced thirty minute run time, (i.e. IWP-3500 (b) - three successive readings taken at ten minute intervals that do not vary more than 3%), causes problems with pumps having no recirculation/test loop. It is easy to see that a program of bearing temperature trends and the evaluation of the results would in some cases be difficult to analyze. Improper interpretation of results could result in unnecessary pump maintenance. In addition, it is impractical to

RELIEF REQUEST NO. PR-1 (CONTINUED)

measure bearing temperatures on many of the pumps in the program. Some specific examples are as follows:

- (1) Core Spray 1(2)A,B-1401 -- pump bearings are lubricated by pump flowage. Temperature of the pumped liquid would seriously affect the accuracy of trends.
- (2) RHR 1(2)A,B,C,D-1002 - same as above.
- (3) RHR SERVICE WATER 1(2)1001-65A,B,C,D - Bearings are contained in an oil-filled reservoir. The ambient temperature of the pump space is changeable thereby varying the start temperature of the data. Results would be difficult if not impossible to trend from test to test.
- (4) High Pressure Coolant Injection - this pump is driven by a steam turbine which exhausts steam into the pressure suppression chamber. Extended run times to stabilize bearing temperatures would create problems in keeping suppression pool temperatures below the Technical Specification limit of 95°F.

RELIEF REQUEST NO. PR-1 (CONTINUED)

- (5) Diesel Generator Cooling Water 1(2)(1/2)-3903 -
Same as RHR Service Water
- (6) Diesel Generator Fuel Oil Transfer 1(2)(1/2)-5203
- this transfer pump pumps fuel oil from the fuel
oil storage tank to the D/G fuel oil day tank.
There is no recirculation test loop for these
pumps, thereby, limiting the run necessary to
gather bearing temperature data.

The foregoing reasons demonstrate that the proposed
program of vibration measurements is a more practical
method of testing which exceeds the requirements of the
ASME Code.

ALTERNATE TESTING: Pump vibration measurements will be taken in
vibration velocity (in/sec). The evaluation of the
readings will be per the attached table.

ALLOWABLE RANGES OF VIBRATION VELOCITY¹

QUANTITY	ACCEPTABLE RANGE	ALERT RANGE		REQUIRED ACTION RANGE	
		LOW VALUES	HIGH VALUES	LOW VALUES	HIGH VALUES
v	When $0 \leq v_r \leq .15$ in/sec	0 to .3 in/sec	None	.3 in/sec to	None $v > .45$ in/sec
v	When $.15$ in/sec $< v_r < .3$ in/sec	0 to .45 in/sec	None	.45 in/sec to .75 in/sec	None $v > .75$ in/sec
v	When $.3$ in/sec $< v_r < .6$ in/sec	0 to 0.9 in/sec	None	0.9 to 1.5 in/sec	None $v > 1.5$ in/sec
v	When $.6$ in/sec $< v_r < 1.0$ in/sec	0 to 1.1 in/sec	None	1.1 to 1.5 in/sec	None $v > 1.5$ in/sec

Where:

v = velocity measured in inches/second, peak.

v_r = reference velocity measurement (initial measurement after installation or rework).

¹ See ASME Technical Paper 78-WA/NE-5, Table 2.

RELIEF REQUEST NO. PR-2

PUMP NUMBER: All pumps in program.

SECTION XI REQUIREMENT: The requirements of IWP-3230(c).
corrective action.

BASIS FOR RELIEF: Relief is requested from the requirements of establishing a new set of reference values following an analysis of a deviation which falls into the "Required Action Range." It is felt that using the original values as a reference will alert the testers to future degradation of the pump more quickly than using a new set of reference values. Pumps which fall into the "Required Action Range" will be analyzed and will remain operative as long as pump operability is not impaired and pump performance meets Technical Specification limits. Maintenance will be performed at the first opportunity to rectify the deviation.

ALTERNATE TESTING: Pump testing will be doubled (i.e., every 45 days) during the interim period and a new set of reference values will be established following the correction of the deviation. Testing will then return to the original frequency (i.e., every 92 days).

RELIEF REQUEST No. PR-3

PUMP NUMBER: 1(2)-1102 (SBLC)

SECTION XI REQUIREMENT: Measure pump inlet pressure

BASIS FOR RELIEF: It is impractical to measure standby liquid control pump inlet pressure in accordance with Section XI requirements. During pump testing, the pump suction is from a test tank rather than the main standby liquid control tank. No instrumentation is provided for measuring inlet pressure, and therefore, the only means available is to correlate tank level to inlet pressure. Since these pumps are positive displacement designs, the measurement of inlet pressure is not critical in judging pump performance. Measuring the discharge pressure and the flow rate is adequate to detect changes in the hydraulic characteristics of the pumps.

ALTERNATE TESTING: Pump discharge pressure will be monitored at each inservice test.

RELIEF REQUEST NO. PR-4

PUMP NUMBER: 1-5203, 2-5203, 1/2-5203

SECTION XI REQUIREMENT: Measure Pump Inlet Pressure

BASIS FOR RELIEF: Relief is requested from the requirement of measuring pump inlet pressure during pump tests. This pump is utilized in transferring fuel oil from the diesel generator fuel oil storage tank to the diesel fuel oil day tank. The configuration of the piping is such that the pump is located above the storage tank. The pump is a positive displacement gear type pump not requiring a positive suction head for proper operation. Since this pump is a positive displacement type, the discharge pressure is independent of the suction pressure and, therefore, inlet pressure data is not important in evaluating pump performance.

ALTERNATE TESTING: Pump discharge pressure will be monitored at each inservice test.

5.0 INSERVICE TESTING PROGRAM FOR VALVES

5.1 GENERAL INFORMATION

The Inservice Testing Program for ISI Class 1, 2 and 3 Valves meets the requirements of Subsection IWV of Section XI of the ASME Boiler and Pressure Vessel Code, 1980 Edition through the Winter 1980 Addenda. Where these, requirements are determined to be impractical, specific requests for relief have been written and included in Section 5.3.

The tables in Section 5.2 list all ISI Class 1, 2 and 3 valves that have been assigned valve categories; valves exempt per IWV-1200 are not listed. The tables are organized by system in order of the assigned system number. A list of these systems and their respective P&ID numbers is given in Table 5.2-1. The following information is included in the tables:

- A. Valve Number lists the valve identification number as shown on the class code flagging P&IDs. The first digit of the valve number indicates the appropriate unit.

- B. P&ID and Coordinates references the class code flagged P&IDs on which the valve appears and its coordinates.
- C. Class is the ISI Classification of the valve. Valves in the diesel fuel oil and air start systems as well as some primary containment isolation valves are included in the program, even though they do not have an ISI Classification. These valves are designated as Class NC (Not Classified).
- D. Valve Category indicates the category assigned to the valve based on the definitions of IWV-2200. Note that the Category E valves, valves which are normally locked (or sealed) open or locked (or sealed) closed to fulfill their function, are not within the scope of Subsection IWV. They are listed in the Tables for information only.
- E. Valve Size lists the nominal pipe size of the valve in inches.
- F. Valve Type lists the valve design as indicated by the following abbreviations.

GATE	GA
GLOBE	GL
CHECK	CK
SAFETY	SV
RELIEF	RV
ELECTROMATIC RELIEF	ERV
BUTTERFLY	BTF
STOP CHECK	SCK
BALL	BALL
RUPTURE DIAPHRAM	RPD
EXCESS FLOW CHECK	XFC

G. Actuator Type lists the type of valve actuator as indicated by the following abbreviations.

MOTOR OPERATOR	MO
AIR OPERATOR	AO
SOLENOID OPERATOR	SO
PILOT SOLENOID ACTUATOR	PS
EXPLOSIVE ACTUATOR	EXP
SELF ACTUATED	SA
MANUAL	M

H. Normal Position indicates the normal position of the valve during plant operation. This is

specified as open (O), closed (C), locked open (LO), and locked closed (LC).

I. Stroke Direction indicates the direction which an active valve must stroke to perform its safety function. Also, the direction in which the valve will be stroked to satisfy the exercising requirements of IWV-3410 or IWV-3520. This may be specified as open (O), closed (C), or both (O&C).

J. Test lists the test or tests that will be performed for each valve to fulfill the requirements of Subsection IWV. The following tests and abbreviations are used:

Seat Leak Test (IWV-3420)

a. Type C Air Leak Test - Primary contain- AT-1
ment isolation valves. The acceptance
criteria for this test is defined in
Relief Request VR-10. Note that 10CFR50
Appendix J, Type A & B tests are not
included in this program even though
these tests will be conducted.

b. Excess Flow Check Valve Test -- Excess AT-2
flow check valves will be tested in
accordance with the Technical Specifi-
cations requirements. For further
information see Relief Request VR-9.

Full Stroke Exercise Test (IWV-3411, BT
3412, 3413)

Valve will be full stroke exercised for
operability in the direction necessary to
fulfill its safety function.

Partial Exercise Test (IWV-3412(a)) BTP

Valve will be part-stroke exercised when
full stroke exercising is impractical.

Check Valve Exercise Test (IWV-3520) CT-1

Check valve will be exercised fully open,
closed or both depending on the safety
function of the valve. Verification of acceptable
system flow through a valve
shall be adequate demonstration of valve
operability.

Relief Valve Set Point Check (IWV-3510)

CT-2

Relief and safety valve set points will be verified in accordance with IWV-3510.

Explosive Valve Tests (IWV-3610)

DT

Explosive valves will be tested in accordance with IWV-3610.

Fail-Safe Test (IWV-3415)

FST

All valves with fail-safe actuators will be tested to verify proper fail-safe operation upon loss of actuator power.

Position Indication Check (IWV-3300)

PIT

All valves with remote position indicators will be checked to verify that remote valve indications accurately reflect valve operation.

- K. Test Mode indicates the frequency at which the above mentioned tests will be performed. The following abbreviations are used:

Normal Operation

OP

Tests which are conducted at least once every 3 months during normal plant operation.

Cold Shutdown

CS

Inservice valve testing at cold shutdown is valve testing which commences within two hours after the plant reaches a cold shutdown condition but in no case later than 48 hours after cold shutdown is reached. This testing continues until all valves are tested or the unit is ready for start-up. Completion of all testing is not a prerequisite to plant start-up. Valve testing which is not completed during a cold shutdown shall be completed during subsequent cold shutdowns that may occur before refueling to meet the code specified testing frequency. In the case of frequent cold shutdowns, valve testing need not be performed more often than once every three months for Category A, B, and C valves.

In the case of longer planned cold shutdowns, the testing need not be started within the 48 hour limitation. However, in these instances, all valve testing must be completed prior to start-up.

Note: It is expected that the required testing will normally be completed in 96

hours following cold shutdown. However, completion of all valve testing during cold shutdown is not required if plant operating conditions will not permit the testing of specific valves.

In the event that a valve must be declared inoperable as a result of cold shutdown testing, the applicable unit start-up limitations will be as stated in the Technical Specification, Limiting Conditions for Operation.

Reactor Refueling

RR

Tests which are conducted during plant refueling outages but not less than once every two years.

Every 5 Years

5Y

Tests which are conducted during plant refueling outages but not less than once every five years (See Article IWV-3511).

- L. Max Stroke Time lists the maximum allowable full stroke time in seconds for power operated valves in Category A or B.

M. Relief Request references either a specific request contained in Section 5.3 or references a Cold Shutdown Justification contained in Section 5.4. Also, included in Section 5.3 are generic relief requests that are not specifically referenced in this column of the tables, but apply to the valve program in general.

N. Remarks lists clarification remarks or indicates that a valve receives an automatic isolation signal. See Table 5.1-1 for the explanation of isolation valve groupings.

TABLE 5.1-1

AUTOMATIC ISOLATION VALVE GROUPINGS

Group 1: The valves in Group 1 are closed upon any one of the following conditions:

1. Reactor low-low water level
2. Main steamline high radiation
3. Main steamline high flow
4. Main steamline tunnel high temperature
5. Main steamline low pressure

Group 2: The actions in Group 2 are initiated by any one of the following conditions:

1. Reactor low water level
2. High drywell pressure

Group 3: Reactor low water level alone initiates the following:

1. Cleanup demineralizer system isolation

Group 4: Isolation valves in the high pressure coolant injection system (HPCI) are closed upon any one of the following signals:

1. HPCI steamline high flow
2. High temperature in the vicinity of the HPCI steamline
3. Low reactor pressure

Group 5: Same as Group 4 except applies to RCIC.

SECTION 5.2

TABLES FOR INSERVICE VALVE TESTING PROGRAM

A. QUAD CITIES UNIT-1

B. QUAD CITIES UNIT-2

TABLE 5.2-1

LIST OF SYSTEMS INCLUDED IN THE VALVE PROGRAM

<u>SYSTEM</u>	<u>SYSTEM</u> <u>NUMBER</u>	UNIT-1	UNIT-2
		REFERENCE <u>P&ID</u>	REFERENCE <u>P&ID</u>
Nuclear Boiler	0200	35-1	77-1
Recirculation	0200	35-2	77-2
Control Rod Drive	0300	41	83
Residual Heat Removal	1000	37&39	79&81
Standby Liquid Control	1100	40	2
Reactor Water Cleanup	1200	47	88
Reactor Core Isolation Cooling	1300	50	89
Core Spray	1400	36	78
Pressure Suppression	1600	34	76
High Pressure Coolant Injection	2300	46	87
Main Steam	3000	13-1&2	60-1&2
Feedwater	3200	15	62
Service Water	3900	22	69
Instrument Air	4700	24-2	71-2
Diesel Air Start	4600	25	72
Rx Building Equipment Drains	4800	43	85
Diesel Fuel Oil	5200	29	29



Commonwealth
Edison

INSERVICE TESTING PROGRAM

ISI-CLASS 1, 2, & 3 VALVES
QUAD CITIES NUCLEAR POWER STATION

UNIT - 1

SYSTEM NUCLEAR BOILER INSTRUMENTATION										P & ID M-35 Sh. 1		REVISION - DATE 2 9/17/84		PAGE 1 of 36
VALVE NUMBER	COORDINATES	CLASS	VALVE CATEGORY	VALVE SIZE	VALVE TYPE	ACTUATOR TYPE	NORMAL POSITION	STROKE DIRECTION	TEST	TEST MODE	MAX. STROKE TIME	RELIEF REQUEST	REMARKS	
1-263-2-15A	D-5	1	AC	0.5	XFC	SA	O	C	AT-2 CT-1	RR RR		VR-9		
1-263-2-13A	D-5	1	AC	0.5	XFC	SA	O	C	AT-2 CT-1	RR RR		VR-9		
1-263-2-19A	C-5	1	AC	0.5	XFC	SA	O	C	AT-2 CT-1	RR RR		VR-9		
1-263-2-17A	D-5	1	AC	0.5	XFC	SA	O	C	AT-2 CT-1	RR RR		VR-9		
1-263-2-11	E-5	1	AC	0.5	XFC	SA	O	C	AT-2 CT-1	RR RR		VR-9		
1-220-54	E-5,6	1	AC	0.5	XFC	SA	O	C	AT-2 CT-1	RR RR		VR-9		
1-263-2-15B	D-3	1	AC	0.5	XFC	SA	O	C	AT-2 CT-1	RR RR		VR-9		
1-263-2-13B	D-3	1	AC	0.5	XFC	SA	O	C	AT-2 CT-1	RR RR		VR-9		
1-263-2-17B	D-3	1	AC	0.5	XFC	SA	O	C	AT-2 CT-1	RR RR		VR-9		
1-263-2-19B	C-3	1	AC	0.5	XFC	SA	O	C	AT-2 CT-1	RR RR		VR-9		
1-263-2-20A	B-5	1	AC	0.5	XFC	SA	O	C	AT-2 CT-1	RR RR		VR-9		
1-263-2-23A	C-5	1	AC	0.5	XFC	SA	O	C	AT-2 CT-1	RR RR		VR-9		
1-263-2-31B	C-5	1	AC	0.5	XFC	SA	O	C	AT-2 CT-1	RR RR		VR-9		



Commonwealth
Edison

INSERVICE TESTING PROGRAM

ISI - CLASS 1, 2, & 3 VALVES
QUAD CITIES NUCLEAR POWER STATION

UNIT - 1

SYSTEM	NUCLEAR BOILER INSTRUMENTATION (CONTINUED)										P & ID	REVISION - DATE	PAGE
											M-35 sh. 1	2 9/17/84	2 of 36
VALVE NUMBER	COORDINATES	CLASS	VALVE CATEGORY	VALVE SIZE	VALVE TYPE	ACTUATION TYPE	NORMAL POSITION	STROKE DIRECTION	TEST	TEST MODE	MAX. STROKE TIME	RELIEF REQUEST	REMARKS
1-263-2-31G	C-5	1	AC	0.5	XPC	SA	O	C	AT-2 CT-1	RR RR		VR-9	
1-263-2-31C	C-5	1	AC	0.5	XPC	SA	O	C	AT-2 CT-1	RR RR		VR-9	
1-263-2-31H	C-5	1	AC	0.5	XPC	SA	O	C	AT-2 CT-1	RR RR		VR-9	
1-263-2-31D	C-5	1	AC	0.5	XPC	SA	O	C	AT-2 CT-1	RR RR		VR-9	
1-263-2-27	A-5	1	AC	0.5	XPC	SA	O	C	AT-2 CT-1	RR RR		VR-9	
1-263-2-25	B-5	1	AC	0.5	XPC	SA	O	C	AT-2 CT-1	RR RR		VR-9	
1-263-2-31J	C-5	1	AC	0.5	XPC	SA	O	C	AT-2 CT-1	RR RR		VR-9	
1-263-2-31E	C-5	1	AC	0.5	XPC	SA	O	C	AT-2 CT-1	RR RR		VR-9	
1-263-2-31K	C-5	1	AC	0.5	XPC	SA	O	C	AT-2 CT-1	RR RR		VR-9	
1-263-2-23B	C-5	1	AC	0.5	XPC	SA	O	C	AT-2 CT-1	RR RR		VR-9	
1-263-42A	C-5	1	AC	0.5	XPC	SA	O	C	AT-2 CT-1	RR RR		VR-9	
1-263-2-20B	B-5	1	AC	0.5	XPC	SA	O	C	AT-2 CT-1	RR RR		VR-9	
1-263-2-20C	B-3	1	AC	0.5	XPC	SA	O	C	AT-2 CT-1	RR RR		VR-9	



Commonwealth
Edison

INSERVICE TESTING PROGRAM

ISI-CLASS 1, 2, & 3 VALVES
QUAD CITIES NUCLEAR POWER STATION

UNIT - 1

SYSTEM NUCLEAR BOILER INSTRUMENTATION (CONTINUED)										P & ID M-35 Sh. 1		REVISION - DATE 2 9/17/84		PAGE 3 of 36
VALVE NUMBER	COORDINATES	CLASS	VALVE CATEGORY	VALVE SIZE	VALVE TYPE	ACTUATOR TYPE	NORMAX POSITION	STROKE DIRECTION	TEST	TEST MODE	MAX. STROKE TIME	RELIEF REQUEST	REMARKS	
1-263-2-23C	C-3	1	AC	0.5	XFC	SA	O	C	AT-2 CT-1	RR RR		VR-9		
1-263-2-31H	C-3	1	AC	0.5	XFC	SA	O	C	AT-2 CT-1	RR RR		VR-9		
1-263-2-31T	C-3	1	AC	0.5	XFC	SA	O	C	AT-2 CT-1	RR RR		VR-9		
1-263-2-31N	C-3	1	AC	0.5	XFC	SA	O	C	AT-2 CT-1	RR RR		VR-9		
1-263-2-31U	C-3	1	AC	0.5	XFC	SA	O	C	AT-2 CT-1	RR RR		VR-9		
1-263-2-31P	C-3	1	AC	0.5	XFC	SA	O	C	AT-2 CT-1	RR RR		VR-9		
1-263-2-33	B-3	1	AC	0.5	XFC	SA	O	C	AT-2 CT-1	RR RR		VR-9		
1-263-2-31V	C-3	1	AC	0.5	XFC	SA	O	C	AT-2 CT-1	RR RR		VR-9		
1-263-2-31R	C-3	1	AC	0.5	XFC	SA	O	C	AT-2 CT-1	RR RR		VR-9		
1-263-2-31W	C-3	1	AC	0.5	XFC	SA	O	C	AT-2 CT-1	RR RR		VR-9		
1-263-2-23D	C-3	1	AC	0.5	XFC	SA	O	C	AT-2 CT-1	RR RR		VR-9		
1-263-2-42B	C-3	1	AC	0.5	XFC	SA	O	C	AT-2 CT-1	RR RR		VR-9		
1-263-2-20D	B-3	1	AC	0.5	XFC	SA	O	C	AT-2 CT-1	RR RR		VR-9		



Commonwealth
Edison

INSERVICE TESTING PROGRAM

ISI - CLASS 1, 2, & 3 VALVES
QUAD CITIES NUCLEAR POWER STATION

UNIT - 1

SYSTEM										P & ID	REVISION - DATE	PAGE	
RECIRCULATION										M-35, Sh. 2	2 9/17/84	4 of 36	
VALVE NUMBER	COORDINATES	CLASS	VALVE CATEGORY	VALVE SIZE	VALVE TYPE	ACTUATOR TYPE	NORMAL POSITION	STROKE DIRECTION	TEST	TEST MODE	MAX. STROKE TIME	RELIEF REQUEST	REMARKS
1-202-5A	D-6	1	B	28	GA	HO	O	C	BT PIT	CS RR	45	J-3, VR13	
1-202-5B	D-3	1	B	28	GA	HO	O	C	BT PIT	CS RR	45	J-3, VR13	
1-220-44	E-2	1	A	0.75	GL	AO	O	C	AT BT PIT FST	RR OP RR OP	5	VR13	GROUP 1 ISOLATION
1-220-45	E-1	1	A	0.75	GL	AO	O	C	AT BT FST	RR OP OP	5	VR13	GROUP 1 ISOLATION
1-220-67A	F-5	1	AC	0.5	XFC	SA	O	C	AT-2 CT-1	RR RR		VR-9	
1-220-67B	F-5	1	AC	0.5	XFC	SA	O	C	AT-2 CT-1	RR RR		VR-9	
1-220-67C	E, F-5	1	AC	0.5	XFC	SA	O	C	AT-2 CT-1	RR RR		VR-9	
1-220-67D	F-5	1	AC	0.5	XFC	SA	O	C	AT-2 CT-1	RR RR		VR-9	
1-220-89A	E-1	1	AC	0.5	XFC	SA	O	C	AT-2 CT-1	RR RR		VR-9	
1-220-89B	E-1	1	AC	0.5	XFC	SA	O	C	AT-2 CT-1	RR RR		VR-9	
1-220-67E	E-5	1	AC	0.5	XFC	SA	O	C	AT-2 CT-1	RR RR		VR-9	
1-220-67F	F-5	1	AC	0.5	XFC	SA	O	C	AT-2 CT-1	RR RR		VR-9	



Commonwealth
Edison

INSERVICE TESTING PROGRAM

ISI-CLASS 1, 2, & 3 VALVES
QUAD CITIES NUCLEAR POWER STATION

UNIT - 1

SYSTEM RECIRCULATION (CONTINUED)										P & ID M-35 Sh. 2		REVISION - DATE 2 9/17/84		PAGE 5 of 36
VALVE NUMBER	COORDINATES	CLASS	VALVE CATEGORY	VALVE SIZE	VALVE TYPE	ACTUATOR TYPE	NORMAL POSITION	STROKE DIRECTION	TEST	TEST MODE	MAX. STROKE TIME	RELIEF REQUEST	REMARKS	
1-220-67G	E-5	1	AC	0.5	XPC	SA	O	C	AT-2 CT-1	RR RR		VR-9		
1-220-67H	F-5	1	AC	0.5	XPC	SA	O	C	AT-2 CT-1	RR RR		VR-9		
1-263-2-6A	B-7	1	AC	0.5	XPC	SA	O	C	AT-2 CT-1	RR RR		VR-9		
1-263-2-5A	B-7	1	AC	0.5	XPC	SA	O	C	AT-2 CT-1	RR RR		VR-9		
1-220-20A	B-5	1	AC	0.5	XPC	SA	O	C	AT-2 CT-1	RR RR		VR-9		
1-220-19A	B-6	1	AC	0.5	XPC	SA	O	C	AT-2 CT-1	RR RR		VR-9		
1-220-22A	D-B	1	AC	0.5	XPC	SA	O	C	AT-2 CT-1	RR RR		VR-9		
1-220-21A	D-B	1	AC	0.5	XPC	SA	O	C	AT-2 CT-1	RR RR		VR-9		
1-220-20B	A-3	1	AC	0.5	XPC	SA	O	C	AT-2 CT-1	RR RR		VR-9		
1-220-19B	A-3	1	AC	0.5	XPC	SA	O	C	AT-2 CT-1	RR RR		VR-9		
1-262-2-6B	B-2	1	AC	0.5	XPC	SA	O	C	AT-2 CT-1	RR RR		VR-9		
1-262-2-5B	B-2	1	AC	0.5	XPC	SA	O	C	AT-2 CT-1	RR RR		VR-9		
1-220-22B	D-1	1	AC	0.5	XPC	SA	O	C	AT-2 CT-1	RR RR		VR-9		



Commonwealth
Edison

INSERVICE TESTING PROGRAM

ISI - CLASS 1, 2, & 3 VALVES
QUAD CITIES NUCLEAR POWER STATION

UNIT - 1

SYSTEM RECIRCULATION (CONTINUED)										P & ID H-35 Sh. 2		REVISION - DATE 2 9/17/84		PAGE 6 of 36	
VALVE NUMBER	COORDINATES	CLASS	VALVE CATEGORY	VALVE SIZE	VALVE TYPE	ACTUATOR TYPE	NORMAL POSITION	STROKE DIRECTION	TEST	TEST MODE	MAX. STROKE TIME	RELIEF REQUEST	REMARKS		
1-220-21B	D-1	1	AC	0.5	XPC	SA	O	C	AT-2 CT-1	RR RR		VR-9			



Commonwealth
Edison

INSERVICE TESTING PROGRAM

ISI - CLASS 1, 2, & 3 VALVES
QUAD CITIES NUCLEAR POWER STATION

UNIT - 1

SYSTEM	P & ID	REVISION	DATE	PAGE									
CONTROL ROD DRIVE	M-41 sh. 1	2	9/17/84	7 of 36									
VALVE NUMBER	COORDINATES	CLASS	VALVE CATEGORY	VALVE SIZE	VALVE TYPE	ACTUATOR TYPE	NORMAL POSITION	STROKE DIRECTION	TEST	TEST MODE	MAX. STROKE TIME	RELIEF REQUEST	REMARKS
(177) 1-0305-127	D-9	1	B	0.75	GA	AO	C	O	BT	*		VR-6	*SCRAM TESTING
(177) 1-0305-126	D-10	1	B	1.0	GA	AO	C	O	BT	*		VR-6	*SCRAM TESTING
(177) 1-0305-114	E-9	2	C	0.75	CK	SA	C	O	CT-1	*		VR-6	*SCRAM TESTING
1-0302-21A	F-6	2	B	1.0	GA	AO	O	C	BT FST	CS CS	30	VR13	
1-0302-21B	F-6	2	B	1.0	GA	AO	O	C	BT FST	CS CS	30	VR13	
1-0302-22A	F-5	2	B	2.0	GA	AO	O	C	BT FST	CS CS	30	VR13	
1-0302-21C	F-1	2	B	1.0	GA	AO	O	C	RT FST	CS	30	VR13	
1-0302-21D	F-1	2	B	1.0	GA	AO	O	C	RT FST	CS	30	VR13	
1-0302-22B	F-5	2	B	2.0	GA	AO	O	C	BT FST	CS	30	VR13	
1-0302-22C	F-3	2	B	2.0	GA	AO	O	C	BT FST	CS	30	VR13	
1-0302-22D	F-2	2	B	2.0	GA	AO	O	C	BT FST	CS	30	VR13	



Commonwealth
Edison

INSERVICE TESTING PROGRAM

ISI - CLASS 1, 2, & 3 VALVES
QUAD CITIES NUCLEAR POWER STATION

UNIT - 1

SYSTEM										P & ID	REVISION - DATE	PAGE	
RESIDUAL HEAT REMOVAL										M-37	2 9/17/84	8 OF 36	
VALVE NUMBER	COORDINATES	CLASS	VALVE CATEGORY	VALVE SIZE	VALVE TYPE	ACTUATOR TYPE	NORMAL POSITION	STROKE DIRECTION	TEST	TEST MODE	MAX. STROKE TIME	RELIEF REQUEST	REMARKS
1-1001-7A	B-6	2	B	14	GA	MO	O	O	BT	OP	90	VR13	
1-1001-7B	E-6	2	B	14	GA	MO	O	O	BT	OP	90	VR13	
1-1001-7C	B-6	2	B	14	GA	MO	O	O	BT	OP	90	VR13	
1-1001-7D	E-6	2	B	14	GA	MO	O	O	BT	OP	90	VR13	
1-1001-67A	B-3	2	C	12	CK	SA	C	O	CT-1	OP			
1-1001-67B	E-3	2	C	12	CK	SA	C	O	CT-1	OP			
1-1001-67C	B-9	2	C	12	CK	SA	C	O	CT-1	OP			
1-1001-67D	E-9	2	C	12	CK	SA	C	O	CT-1	OP			
1-1001-125A	B-5	2	C	1	RV	SA	C	O	CT-2	5Y			
1-1001-125B	E-5	2	C	1	RV	SA	C	O	CT-2	5Y			
1-1001-125C	B-7	2	C	1	RV	SA	C	O	CT-2	5Y			
1-1001-125D	E-7	2	C	1	RV	SA	C	O	CT-2	5Y			
1-1001-43A	B-4	2	B	14	GA	MO	C	C	BT	OP	105	VR13	
1-1001-43B	E-4	2	B	14	GA	MO	C	C	BT	OP	105	VR13	
1-1001-43C	B-B	2	B	14	GA	MO	C	C	BT	OP	105	VR13	
1-1001-43D	E-B	2	B	14	GA	MO	C	C	BT	OP	105	VR13	
1-1001-6A	F-5	2	E	24	BTF	M	LO		NA				
1-1001-6B	B-6	2	E	24	BTF	M	LO		NA				
1-1001-42A	B-5	2	E	14	GA	M	LC		NA				



Commonwealth
Edison

INSERVICE TESTING PROGRAM

ISI-CLASS 1, 2, & 3 VALVES
QUAD CITIES NUCLEAR POWER STATION

UNIT - 1

SYSTEM	P & ID	REVISION - DATE	PAGE										
RESIDUAL HEAT REMOVAL (CONTINUED)	M -37	2 9/17/84	9 of 36										
VALVE NUMBER	COORDINATES	CLASS	VALVE CATEGORY	VALVE SIZE	VALVE TYPE	ACTUATOR TYPE	NORMAL POSITION	STROKE DIRECTION	TEST	TEST MODE	MAX. STROKE TIME	RELIEF REQUEST	REMARKS
1-1001-42B	E-5	2	E	14	GA	H	LC		NA				
1-1001-42C	C-6	2	E	14	GA	H	LC		NA				
1-1001-42D	E-6	2	E	14	GA	H	LC		NA				
1-1001-66A	B-3	2	E	12	GA	H	LO		NA				
1-1001-66B	E-3	2	E	12	GA	H	LO		NA				
1-1001-66C	B-9	2	E	12	GA	H	LO		NA				
1-1001-66D	E-9	2	E	12	GA	H	LO		NA				
1-1001-15A	B-2	2	E	18	GA	H	LO		NA				
1-1001-15B	B-9	2	E	18	GA	H	LO		NA				
1-1001-17A	A-2	2	E	18	GA	H	LO		NA				
1-1001-17B	A-10	2	E	18	GA	H	LO		NA				
1-1001-141A	B-3	2	E	2	GA	H	LO		NA				
1-1001-141B	E-3	2	E	2	GA	H	LO		NA				
1-1001-141C	B-9	2	E	2	GA	H	LO		NA				
1-1001-141D	E-9	2	E	2	GA	H	LO		NA				
1-1001-142A	B-3	2	C	2	CK	SA	C	0	CT-1	OP*			
1-1001-142B	E-3	2	C	2	CK	SA	C	0	CT-1	OP*			
1-1001-142C	B-9	2	C	2	CK	SA	C	0	CT-1	OP*			
1-1001-142D	E-9	2	C	2	CK	SA	C	0	CT-1	OP*			

*OPENSTROKE VERIFIED BY
PUMP TEST



Commonwealth
Edison

INSERVICE TESTING PROGRAM

ISI-CLASS 1, 2, & 3 VALVES
QUAD CITIES NUCLEAR POWER STATION

UNIT - 1

SYSTEM	P & ID	REVISION	DATE	PAGE									
RESIDUAL HEAT REMOVAL (CONTINUED)	M-39 sh. 1	2	9/17/84	10 of 36									
VALVE NUMBER	COORDINATES	CLASS	VALVE CATEGORY	VALVE SIZE	VALVE TYPE	ACTUATOR TYPE	NORMAL POSITION	STROKE DIRECTION	TEST	TEST MODE	MAX. STROKE TIME	RELIEF REQUEST	REMARKS
1-1001-29A	E-6	1	A	16	GA	MO	C	O	AT-1 BT	RR CS	25	J-7, VR13	
1-1001-29B	E-8	1	A	16	GA	MO	C	O	AT-1 BT	RR CS	25	J-7, VR13	
1-1001-47	C-5	1	A	20	GA	MO	O&C	C	AT-1 BT	RR CS	40	J-4, VR13	GROUP 2 ISOLATION
1-1001-50	D-4	1	A	20	GA	MO	O&C	C	AT-1 BT	RR CS	40	J-4, VR13	GROUP 2 ISOLATION
1-1001-60	F-3	1	A	4	GA	MO	O&C	C	AT-1 BT	RR CS	25	J-4, VR13	GROUP 2 ISOLATION
1-1001-63	F-4	1	A	4	GA	MO	O&C	C	AT-1 BT	RR CS	25	J-4, VR13	GROUP 2 ISOLATION
1-1001-68A	E-5	1	C	16	CK	SA	C	O	PIT CT-1	RR CS		J-2	
1-1001-68B	E-4	1	C	16	CK	SA	C	O	PIT CT-1	RR CS		J-2	
1-1001-16A	A-7	2	B	18	GL	MO	O&C	O	BT	OP	125	VR13	
1-1001-16B	A-2	2	B	18	GL	MO	O&C	O	BT	OP	125	VR13	
1-1001-18A	C-6	2	B	3	GA	MO	C	O&C	BT	OP	17	VR13	
1-1001-18B	C-3	2	B	3	GA	MO	C	O&C	BT	OP	17	VR13	
1-1001-19A	B-8	2	B	18	GA	MO	O	O	BT	CS	125	J-6, VR13	
1-1001-19B	B-2	2	B	18	GA	MO	O	O	BT	CS	125	J-6, VR13	
1-1001-20	B-3	2	A	3	GA	MO	O&C	C	AT-1 BT	RR OP	25	VR13	GROUP 2 ISOLATION



Commonwealth
Edison

INSERVICE TESTING PROGRAM

ISI - CLASS 1, 2, & 3 VALVES
QUAD CITIES NUCLEAR POWER STATION

UNIT - 1

SYSTEM	P & ID	REVISION - DATE	PAGE										
RESIDUAL HEAT REMOVAL (CONTINUED)	M-39 sh. 1	2 9/17/84	11 of 36										
VALVE NUMBER	COORDINATES	CLASS	VALVE CATEGORY	VALVE SIZE	VALVE TYPE	ACTUATOR TYPE	NORMAL POSITION	STROKE DIRECTION	TEST	TEST MODE	MAX. STROKE TIME	RELIEF REQUEST	REMARKS
1-1001-21	B-3	2	A	3	GA	MO	O&C	C	AT-1 BT	RR OP	25	VR13	GROUP 2 ISOLATION
1-1001-22A	C-8	2	C	1	RV	SA	C	O	CT-2	RR			
1-1001-22B	E-2	2	C	1	RV	SA	C	O	CT-2	RR			
1-1001-23A	E-6	2	A	10	GA	MO	C	C	AT-1 BT	RR OP	15	VR13	
1-1001-23B	E-3	2	A	10	GA	MO	C	C	AT-1 BT	RR OP	15	VR13	
1-1001-26A	E-5	2	A	10	GA	MO	C	C	AT-1 BT	RR OP	15	VR13	
1-1001-26B	E-4	2	A	10	GA	MO	C	C	AT-1 BT	RR OP	15	VR13	
1-1001-28A	E-6	2	B	16	GL	MO	O	O	BT	CS	90	J-7, VR13	
1-1001-28B	E-3	2	B	16	GL	MO	O	O	BT	CS	90	J-7, VR13	
1-1001-36A	E-7	2	A	14	GL	MO	C	O&C	AT-1 BT	RR OP	60	VR13	
1-1001-36B	D-3	2	A	14	GL	MO	C	O&C	AT-1 BT	RR OP	60	VR13	
1-1001-37A	E-7	2	A	6	GL	MO	C	O&C	AT-1 BT	RR OP	60	VR13	
1-1001-37B	D-3	2	A	6	GL	MO	C	O&C	AT-1 BT	RR OP	60	VR13	
1-1001-34A	E-7	2	A	16	GA	MO	C	O&C	AT-1 BT	RR OP	125	VR13	
1-1001-34B	E-3	2	A	16	GA	MO	C	O&C	AT-1 BT	RR OP	125	VR13	



Commonwealth
Edison

INSERVICE TESTING PROGRAM

ISI - CLASS 1, 2, & 3 VALVES
QUAD CITIES NUCLEAR POWER STATION

UNIT - 1

SYSTEM	P & ID	REVISION - DATE	PAGE
RESIDUAL HEAT REMOVAL (CONTINUED)	M-39 sh. 1	2 9/17/84	12 of 36

VALVE NUMBER	COORDINATES	CLASS	VALVE CATEGORY	VALVE SIZE	VALVE TYPE	ACTUATOR TYPE	NORMAL POSITION	STROKE DIRECTION	TEST	TEST MODE	MAX. STROKE TIME	RELIEF REQUEST	REMARKS
1-1001-33A	E-5	I	E	16	GA	M	LO	NA					
1-1001-33B	E-4	I	E	16	GA	M	LO	NA					



Commonwealth
Edison

INSERVICE TESTING PROGRAM

ISI - CLASS 1, 2, & 3 VALVES
QUAD CITIES NUCLEAR POWER STATION

UNIT - 1

SYSTEM RESIDUAL HEAT REMOVAL (CONTINUED)										P & ID M-39 sh. 2	REVISION - DATE 2 9/17/84	PAGE 13 of 36	
VALVE NUMBER	COORDINATES	CLASS	VALVE CATEGORY	VALVE SIZE	VALVE TYPE	ACTUATOR TYPE	NORMAL POSITION	STROKE DIRECTION	TEST	TEST MODE	MAX. STROKE TIME	RELIEF REQUEST	REMARKS
1-1001-2A	D-7	3	C	12	CK	SA	C	O	CT-1	OP			
1-1001-2B	B-7	3	C	12	CK	SA	C	O	CT-1	OP			
1-1001-2C	D-2	3	C	12	CK	SA	C	O	CT-1	OP			
1-1001-2D	B-2	3	C	12	CK	SA	C	O	CT-1	OP			
1-1001-5A	E-6	3	B	12	GL	MO	C	O&C	BT	OP	90	VR13	
1-1001-5B	E-3	3	B	12	GL	MO	C	O&C	BT	OP	90	VR13	
1-1001-1A	C-6	3	E	14	GA	M	LO		NA				
1-1001-1B	B-6	3	E	14	GA	M	LO		NA				
1-1001-1C	C-3	3	E	14	GA	M	LO		NA				
1-1001-1D	B-3	3	E	14	GA	M	LO		NA				
1-1001-3A	D-7	3	E	12	GA	M	LO		NA				
1-1001-3B	B-3	3	E	12	GA	M	LO		NA				
1-1001-3C	D-2	3	E	12	GA	M	LO		NA				
1-1001-3D	B-2	3	E	12	GA	M	LO		NA				
1-1001-201A	E-6	NC	E	14	BTF	M	LO		NA				
1-1001-201B	E-3	NC	E	14	BTF	M	LO		NA				
1/2-1099-1	D-8	3	E	16	GA	M	LC		NA				



Commonwealth
Edison

INSERVICE TESTING PROGRAM

ISI - CLASS 1, 2, & 3 VALVES
QUAD CITIES NUCLEAR POWER STATION

UNIT - 1

SYSTEM STANDBY LIQUID CONTROL										P & ID M-40	REVISION - DATE 2 9/17/84	PAGE 14 of 36	
VALVE NUMBER	COORDINATES	CLASS	VALVE CATEGORY	VALVE SIZE	VALVE TYPE	ACTUATOR TYPE	NORMAL POSITION	STROKE DIRECTION	TEST	TEST MODE	MAX. STROKE TIME	RELIEF REQUEST	REMARKS
1-1101-15	C-3	1	C	1.5	CK	SA	C	O	CT-1	CS/RR		VR-5	
1-1101-16	C-3	1	C	1.5	CK	SA	C	O	CT-1	CS/RR		VR-5	
1-1106A	C-4	2	D	1.5		EXP	C	O	DT	RR			
1-1106B	D-4	2	D	1.5		EXP	C	O	DT	RR			
1-1101-43A	D-6	2	C	1.5	CK	SA	C	O	CT-1	OP			
1-1101-43B	E-5	2	C	1.5	CK	SA	C	O	CT-1	OP			
1-1105A	C-6	2	C	1.5	RV	SA	C	O	CT-2	5Y			
1-1105B	D-5	2	C	1.5	RV	SA	C	O	CT-2	5Y			
1-1101-4	E-8	2	E	2.5	GA	M	LO		NA				
1-1101-8	D-8	2	E	2.5	GA	M	LC		NA				
1-1101-3A	D-7	2	E	2.5	GA	M	LO		NA				
1-1101-3B	E-7	2	E	2.5	GA	M	LO		NA				
1-1101-10	D-7	2	E	1	GL	M	LC		NA				
1-1101-2A	D-5	2	E	1.5	GL	M	LO		NA				
1-1101-2B	E-5	2	E	1.5	GL	M	LO		NA				
1-1101-22	C-4	2	E	1.5	GL	M	LC		NA				
1-1101-9B	D-4	2	E	1	GL	M	LC		NA				
1-1101-23	D-3	2	E	1.5	GL	M	LO		NA				
1-1101-1	D-2	1	E	1.5	GL	M	LO		NA				



Commonwealth
Edison

INSERVICE TESTING PROGRAM

ISI - CLASS 1, 2, & 3 VALVES
QUAD CITIES NUCLEAR POWER STATION

UNIT - 1

SYSTEM REACTOR CORE ISOLATION COOLING										P & ID M-50	REVISION - DATE 2 9/17/84	PAGE 16 of 36	
VALVE NUMBER	COORDINATES	CLASS	VALVE CATEGORY	VALVE SIZE	VALVE TYPE	ACTUATOR TYPE	NORMAL POSITION	STROKE DIRECTION	TEST	TEST MODE	MAX. STROKE TIME	RELIEF REQUEST	REMARKS
1-1301-16	B-2	1	A	3	GA	MO	O	C	AT-1 BT PIT	RR OP RR	25	VR13	GROUP 5 ISOLATION
1-1301-17	B-3	1	A	3	GA	MO	O	C	AT-1 BT	RR OP	25	VR13	GROUP 5 ISOLATION
1-1301-40	D-2	NC	AC	2	CK	SA	C	C	AT-1 CT-1	RR RR		VR-8	
1-1301-41	D-2	NC	AC	8	CK	SA	C	C	AT-1 CT-1	RR RR		VR-8	
1-1301-15A	B-2	1	AC	.5	XFC	SA	O	C	AT-2 CT-1	RR RR		VR-9	
1-1301-15B	B-2	1	AC	.5	XFC	SA	O	C	AT-2 CT-1	RR RR		VR-9	



Commonwealth
Edison

INSERVICE TESTING PROGRAM

ISI-CLASS 1, 2, & 3 VALVES
QUAD CITIES NUCLEAR POWER STATION

UNIT - 1

SYSTEM CORE SPRAY										P & ID M-36		REVISION - DATE 2 9/17/84		PAGE 17 of 36	
VALVE NUMBER	COORDINATES	CLASS	VALVE CATEGORY	VALVE SIZE	VALVE TYPE	ACTUATOR TYPE	NORMAL POSITION	STROKE DIRECTION	TEST	TEST MODE	MAX. STROKE TIME	RELIEF REQUEST	REMARKS		
1-1402-9A	C-3	1	C	10	CK	SA	C	O	CT-1 PIT	CS RR		J-2			
1-1402-9B	C-4	1	C	10	CK	SA	C	O	CT-1 PIT	CS RR		J-2			
1-1402-25A	C-2	1	B	10	GA	MO	C	O	BT	OP	15	VR13			
1-1402-25B	C-5	1	B	10	GA	MO	C	O	BT	OP	15	VR13			
1-1402-24A	B-2	2	B	10	GA	MO	O	O	BT	OP	15	VR13			
1-1402-24B	B-5	2	B	10	GA	MO	O	O	BT	OP	15	VR13			
1-1402-28A	C-9	2	C	2	RV	SA	C	O	CT-2	5Y					
1-1402-28B	D-6	2	C	2	RV	SA	C	O	CT-2	5Y					
1-1402-38A	C-8	2	B	1.5	GA	MO	O	C	BT	OP	12	VR13			
1-1402-38B	D-7	2	B	1.5	GA	MO	O	C	BT	OP	12	VR13			
1-1402-8A	E-9	2	CE	12	SCK	SA	C/LO	O	CT-1	OP					
1-1402-8B	E-6	2	CE	12	SCK	SA	C/LO	O	CT-1	OP					
1-1402-31A	D-3	1	AC	.5	XFC	SA	O	C	AT-2 CT-1	RR RR		VR-9			
1-1402-31B	D-4	1	AC	.5	XFC	SA	O	C	AT-2 CT-1	RR RR		VR-9			
1-1402-6A	D-3	1	E	10	GA	H	LO		NA						
1-1402-6D	D-3	1	E	10	GA	H	LO		NA						
1-1402-2A	G-7	2	E	12	GA	H	LC		NA						



Commonwealth
Edison

INSERVICE TESTING PROGRAM

ISI - CLASS 1, 2, & 3 VALVES
QUAD CITIES NUCLEAR POWER STATION

UNIT - 1

SYSTEM CORE SPRAY (CONTINUED)										P & ID M-36	REVISION - DATE 2 9/17/84		PAGE 18 of 36
VALVE NUMBER	COORDINATES	CLASS	VALVE CATEGORY	VALVE SIZE	VALVE TYPE	ACTUATOR TYPE	NORMAL POSITION	STROKE DIRECTION	TEST	TEST MODE	MAX. STROKE TIME	RELIEF REQUEST	REMARKS
1-1402-2B	G-4	2	E	12	GA	M	LC		NA				
1-1402-34A	G-4	2	E	18	BTF	M	LO		NA				
1-1402-34B	F-3	2	E	18	BTF	M	LO		NA				
1-1402-4A	A-8	2	B	8	GL	MO	C	C	BT	OP	60	VR-13	
1-1402-4B	C-7	2	B	8	GL	MO	C	C	BT	OP	60	VR-13	
1-1402-13A	E-9	?	CE	1.5	SCK	SA/M	C/LO	O	CT-1	* OP			
1-1402-13B	E-6	2	CE	1.5	SCK	SA/M	C/LO	O	CT-1	* OP			

* Open Stroke
Verified by Pump
Test



Commonwealth
Edison

INSERVICE TESTING PROGRAM

ISI - CLASS 1, 2, & 3 VALVES
QUAD CITIES NUCLEAR POWER STATION

UNIT - 1

SYSTEM PRESSURE SUPPRESSION										P&ID M-34 sh. 1	REVISION - DATE 2 9/17/84	PAGE 19 of 36	
VALVE NUMBER	COORDINATES	CLASS	VALVE CATEGORY	VALVE SIZE	VALVE TYPE	ACTUATOR TYPE	NORMAL POSITION	STROKE DIRECTION	TEST	TEST MODE	MAX. STROKE TIME	RELIEF REQUEST	REMARKS
1-1601-21	C-6	NC	A	18	BTF	AO	C	C	AT-1 BT FST	RR OP OP	10	VR13	GROUP 2 ISOLATION
1-1601-22	C-6	NC	A	18	BTF	AO	C	C	AT-1 BT FST	RR OP OP	10	VR13	GROUP 2 ISOLATION
1-1601-55	A-6	NC	A	4	GA	AO	O	C	AT-1 BT FST	RR OP OP	10	VR13	GROUP 2 ISOLATION
1-1601-56	D-6	NC	A	18	BTF	AO	O	C	AT-1 BT FST	RR OP OP	10	VR13	GROUP 2 ISOLATION
1-1601-57	C-9	NC	A	1	GL	MO	O	C	AT-1 BT FST	RR OP OP	15	VR13	GROUP 2 ISOLATION
1-1601-58	D-7	NC	A	1	GL	AO	C	C	AT-1 BT FST	RR OP OP	15	VR13	GROUP 2 ISOLATION
1-1601-59	D-7	NC	A	1	GL	AO	O	C	AT-1 BT FST	RR OP OP	15	VR13	GROUP 2 ISOLATION
1-1601-20A	D-9	NC	A	20	BTF	AO	C	O&C	AT-1 BT FST	RR CS OP	10	J-B, VR13	
1-1601-31A	D-9	NC	AC	20	CK	SA	C	O&C	AT-1 CT-1	RR OP			
1-1601-20B	E-9	NC	A	20	BTF	AO	C	O&C	AT-1 BT FST	RR CS OP	10	J-B, VR13	



Commonwealth
Edison

INSERVICE TESTING PROGRAM

ISI - CLASS 1, 2, & 3 VALVES
QUAD CITIES NUCLEAR POWER STATION

UNIT - 1

SYSTEM										P & ID		REVISION - DATE		PAGE
PRESSURE SUPPRESSION (CONTINUED)										M-34 sh: 1		2 9/17/84		20 of 36
VALVE NUMBER	COORDINATES	CLASS	VALVE CATEGORY	VALVE SIZE	VALVE TYPE	ACTUATOR TYPE	NORMAL POSITION	STROKE DIRECTION	TEST	TEST MODE	MAX. STROKE TIME	RELIEF REQUEST	REMARKS	
1-1601-31B	E-9	NC	AC	20	CK	SA	C	D&C	AT-1 CT-1	RR OP				
1-1601-23	B-3	NC	A	18	BTF	AO	C	C	AT-1 BT FST	RR OP OP	10	VR13	GROUP 2 ISOLATION	
1-1601-24	B-2	NC	A	18	BTF	AO	C	C	AT-1 BT FST	RR OP OP	10	VR13	GROUP 2 ISOLATION	
1-1601-60	E-2	NC	A	18	BTF	AO	C	C	AT-1 BT FST	RR OP OP	10	VR13	GROUP 2 ISOLATION	
1-1601-61	F-2	NC	A	2	GL	AO	C	C	AT-1 BT FST	RR OP OP	15	VR13	GROUP 2 ISOLATION	
1-1601-62	B-2	NC	A	2	GL	AO	C	C	AT-1 BT FST	RR OP OP	15	VR13	GROUP 2 ISOLATION	
1-1601-63	A-2	NC	A	6	BTF	AO	C	C	AT-1 BT FST	RR OP OP	10	VR13	GROUP 2 ISOLATION	
1-8803	C-6	NC	A	2	GL	AO	O	C	AT-1 BT FST	RR OP OP	10	VR13	GROUP 2 ISOLATION	
1-8804	D-6	NC	A	2	GL	AO	O	C	AT-1 BT FST	RR OP OP	10	VR13	GROUP 2 ISOLATION	
1-8801A	C-3	NC	A	0.5	GL	AO	O	C	AT-1 BT FST	RR OP OP	10	VR13	GROUP 2 ISOLATION	



Commonwealth
Edison

INSERVICE TESTING PROGRAM

ISI-CLASS 1, 2, & 3 VALVES
QUAD CITIES NUCLEAR POWER STATION

UNIT - 1

SYSTEM	PRESSURE SUPPRESSION (CONTINUED)								P & ID	REVISION - DATE	PAGE		
									M-34 sh. 1	2 9/17/84	21 of 36		
VALVE NUMBER	COORDINATES	CLASS	VALVE CATEGORY	VALVE SIZE	VALVE TYPE	ACTUATOR TYPE	NORMAL POSITION	STROKE DIRECTION	TEST	TEST MODE	MAX. STROKE TIME	RELIEF REQUEST	REMARKS
1-8801B	D-3	NC	A	0.5	GL	AO	O	C	AT-1 BT FST	RR OP OP	10	VR13	GROUP 2 ISOLATION
1-8801C	D-3	NC	A	0.5	GL	AO	O	C	AT-1 BT FST	RR OP OP	10	VR13	GROUP 2 ISOLATION
1-8801D	E-3	NC	A	0.5	GL	AO	O	C	AT-1 BT FST	RR OP OP	10	VR13	GROUP 2 ISOLATION
1-8802A	C-3	NC	A	0.5	GL	AO	O	C	AT-1 BT FST	RR OP OP	10	VR13	GROUP 2 ISOLATION
1-8802B	D-3	NC	A	0.5	GL	AO	O	C	AT-1 BT FST	RR OP OP	10	VR13	GROUP 2 ISOLATION
1-8802C	D-3	NC	A	0.5	GL	AO	O	C	AT-1 BT FST	RR OP OP	10	VR13	GROUP 2 ISOLATION
1-8802D	E-3	NC	A	0.5	GL	AO	O	C	AT-1 BT FST	RR OP OP	10	VR13	GROUP 2 ISOLATION
1-1601-32A	E-2	NC	C	18	CK	SA	C	O&C	CT-1	OP			
1-1601-32B	E-2	NC	C	18	CK	SA	C	O&C	CT-1	OP			
1-1601-32C	E-2	NC	C	18	CK	SA	C	O&C	CT-1	OP			
1-1601-32D	E-2	NC	C	18	CK	SA	C	O&C	CT-1	OP			
1-1601-32E	E-2	NC	C	18	CK	SA	C	O&C	CT-1	OP			



Commonwealth
Edison

INSERVICE TESTING PROGRAM

ISI - CLASS 1, 2, & 3 VALVES
QUAD CITIES NUCLEAR POWER STATION

UNIT - 1

SYSTEM										P & ID		REVISION - DATE		PAGE	
PRESSURE SUPPRESSION (CONTINUED)										M-34 sh. 1		2 9/17/84		22 of 36	
VALVE NUMBER	COORDINATES	CLASS	VALVE CATEGORY	VALVE SIZE	VALVE TYPE	ACTUATOR TYPE	NORMAL POSITION	STROKE DIRECTION	TEST	TEST MODE	MAX. STROKE TIME	RELIEF REQUEST	REMARKS		
1-1601-32F	E-2	NC	C	10	CK	SA	C	O&C	CT-1	OP					
1-1601-33A	E-7	NC	C	10	CK	SA	C	O&C	CT-1	OP					
1-1601-33B	E-7	NC	C	10	CK	SA	C	O&C	CT-1	OP					
1-1601-33C	E-7	NC	C	10	CK	SA	C	O&C	CT-1	OP					
1-1601-33D	P-7	NC	C	10	CK	SA	C	O&C	CT-1	OP					
1-1601-33E	E-7	NC	C	10	CK	SA	C	O&C	CT-1	OP					
1-1601-33F	E-7	NC	C	10	CK	SA	C	O&C	CT-1	OP					
1-220-01A	E-4	NC	C	1	CK	SA	C	O	CT-1	CS		VR-14			
1-220-01B	E-4	NC	C	1	CK	SA	C	O	CT-1	CS		VR-14			
1-220-01C	E-4	NC	C	1	CK	SA	C	O	CT-1	CS		VR-14			
1-220-01D	E-5	NC	C	1	CK	SA	C	O	CT-1	CS		VR-14			
1-220-01E	E-5	NC	C	1	CK	SA	C	O	CT-1	CS		VR-14			
1-220-105A	D-4	NC	C	8	CK	SA	C	O	CT-1	CS		VR-14			
1-220-105B	E-4	NC	C	8	CK	SA	C	O	CT-1	CS		VR-14			
1-220-105C	D-5	NC	C	8	CK	SA	C	O	CT-1	CS		VR-14			
1-220-105D	D-5	NC	C	8	CK	SA	C	O	CT-1	CS		VR-14			
1-220-105E	E-5	NC	C	8	CK	SA	C	O	CT-1	CS		VR-14			



Commonwealth
Edison

INSERVICE TESTING PROGRAM

ISI - CLASS 1, 2, & 3 VALVES
QUAD CITIES NUCLEAR POWER STATION

UNIT - 1

SYSTEM	P & ID	REVISION - DATE	PAGE										
HIGH PRESSURE COOLANT INJECTION	M-46	2 9/17/84	23 of 36										
VALVE NUMBER	COORDINATES	CLASS	VALVE CATEGORY	VALVE SIZE	VALVE TYPE	ACTUATOR TYPE	NORMAL POSITION	STROKE DIRECTION	TEST	TEST MODE	MAX. STROKE TIME	RELIEF REQUEST	REMARKS
1-2301-4	C-9	1	A	10	GA	MO	O	O&C	AT BT PIT	RR CS RR	50	J-5, VR13	GROUP 4 ISOLATION
1-2301-5	B-10	1	A	10	GA	MO	O	O&C	AT BT	RR CS	50	J-5, VR13	GROUP 4 ISOLATION
1-2301-3	A-6	2	B	10	GA	MO	C	O	BT	OP	25	VR13	
1-2301-68	A-6	2	D	16	RPD	SA	C	O	*				*PER MANUFACTURER RECOMMENDATION
1-2301-69	A-6	2	D	16	RPD	SA	C	O	*				*PER MANUFACTURER RECOMMENDATION
1-2301-29	B-9	2	B	1	GL	AO	O	C	BT FST	OP OP	10	VR13	
1-2301-34	D-7	2	AC	2	CK	SA	C	O&C	AT-1 CT-1	RR OP/RR*		VR-8	*OPEN STROKE VERIFIED BY PUMP TEST
1-2301-45	B-8	2	AC	24	CK	SA	C	O&C	AT-1 CT-1	RR OP/RR*		VR-8	*OPEN STROKE VERIFIED BY PUMP TEST
1-2301-35	E-7	2	B	16	GA	MO	C	O&C	BT	OP	120	VR13	
1-2301-36	E-9	2	B	16	GA	MO	C	O&C	BT	OP	120	VR13	
1-2301-6	F-2	2	B	16	GA	MO	O	O&C	BT	OP	120	VR13	
1-2301-20	E-2	2	C	16	CK	SA	O	O	CT-1	OP			
1-2301-14	C-5	2	B	4	GL	MO	C	O&C	BT	OP	26	VR13	
1-2301-39	E-8	2	C	16	CK	SA	C	O	CT-1	*		VR-7	*SEE VR-7
1-2301-40	D-7	NC	C	4	CK	SA	C	O	CT-1	OP**			

** Openstroke verified by pump test.



Commonwealth
Edison

INSERVICE TESTING PROGRAM

ISI - CLASS 1, 2, & 3 VALVES
QUAD CITIES NUCLEAR POWER STATION

UNIT - 1

SYSTEM HIGH PRESSURE COOLANT INJECTION (CONTINUED)										P & ID M-46	REVISION - DATE 2 9/17/84		PAGE 24 of 36
VALVE NUMBER	COORDINATES	CLASS	VALVE CATEGORY	VALVE SIZE	VALVE TYPE	ACTUATOR TYPE	NORMAL POSITION	STROKE DIRECTION	TEST	TEST MODE	MAX STROKE TIME	RELIEF REQUEST	REMARKS
1-2301-8	D-6	2	B	14	GA	MO	C	O	BT	OP	45	VR13	
1-2301-7	D-6	2	C	14	CK	SA	C	O	PIT CT-1	RR CS		J-2	
1-2301-74	B-8	2	CE	12	SCK	SA	C/LO	O	CT-1	OP*			*OPEN STROKE VERIFIED BY PUMP TEST
1-2301-26	D-9	1	AC	.5	XFC	SA	O	C	AT-2 CT-1	RR RR		VR-9	
1-2301-27	D-9	1	AC	.5	XFC	SA	O	C	AT-2 CT-1	RR RR		VR-9	
1-2301-22	B-1	2	E	16	GA	H	LO			NA			
1-2301-56	F-8	2	E	16	BTF	H	LO			NA			
1-2301-71	D-7	2	CE	2	SCK	SA/M	C/LO	O	CT-1	OP*			*OPEN STROKE VERIFIED BY PUMP TEST
1-2301-9	D-5	2	B	14	GA	MO	O	O	BT	OP	45	VR13	
1-2301-10	E-5	2	B	12	GL	MO	C	C	BT	OP	60	VR13	



Commonwealth
Edison

INSERVICE TESTING PROGRAM

ISI-CLASS 1, 2, & 3 VALVES
QUAD CITIES NUCLEAR POWER STATION

UNIT - 1

SYSTEM MAIN STEAM										P & ID M-13 Sh. 1		REVISION - DATE 2 9/17/84		PAGE 25 of 36
VALVE NUMBER	COORDINATES	CLASS	VALVE CATEGORY	VALVE SIZE	VALVE TYPE	ACTUATOR TYPE	NORMAL POSITION	STROKE DIRECTION	TEST	TEST MODE	MAX STROKE TIME	RELIEF REQUEST	REMARKS	
1-203-1A	F-4	1	A	20	GL	AO	O	C	AT-1 BTP BT FST PIT	RR OP CS CS RR	5	J-1 VR13	GROUP 1 ISOLATION	
1-203-1B	D-4	1	A	20	GL	AO	O	C	AT-1 BTP BT FST PIT	RR OP CS CS RR	5	J-1 VR13	GROUP 1 ISOLATION	
1-203-1C	C-1	1	A	20	GL	AO	O	C	AT-1 BTP BT FST PIT	RR OP CS CS RR	5	J-1 VR13	GROUP 1 ISOLATION	
1-203-1D	B-4	1	A	20	GL	AO	O	C	AT-1 BTP BT FST PIT	RR OP CS CS RR	5	J-1 VR13	GROUP 1 ISOLATION	
1-220-1	E-4	1	A	3	GA	MO	C	C	AT-1 BT	RR OP	35	VR13	GROUP 1 ISOLATION	
1-203-3A	F-7	1	BC	6	ERV/SV	PS/SA	C	O	BT CT-2	* RR	*	VR-1 VR-2	*SEE VR-1	
1-203-3B	D-6	1	BC	6	ERV	PS	C	O	BT CT-2	* RR	*	VR-1 VR-2	*SEE VR-1	
1-203-3C	C-7	1	BC	6	ERV	PS	C	O	BT CT-2	* RR	*	VR-1 VR-2	*SEE VR-1	
1-203-3D	B-7	1	BC	6	ERV	PS	C	O	BT CT-2	* RR	*	VR-1 VR-2	*SEE VR-1	



Commonwealth
Edison

INSERVICE TESTING PROGRAM

ISI - CLASS 1, 2, & 3 VALVES
QUAD CITIES NUCLEAR POWER STATION

UNIT - 1

SYSTEM MAIN STEAM (CONTINUED)										P & ID M-13 Sh. 1		REVISION - DATE 2 9/17/84		PAGE 26 of 36
VALVE NUMBER	COORDINATES	CLASS	VALVE CATEGORY	VALVE SIZE	VALVE TYPE	ACTUATOR TYPE	NORMAL POSITION	STROKE DIRECTION	TEST	TEST MODE	MAX. STROKE TIME	RELIEF REQUEST	REMARKS	
I-203-3E	D-8	1	BC	6	ERV	PS	C	O	BT CT-2	* RR	*	VR-1 VR-2	*SEE VR-1	
I-203-4A	F-8	1	C	6	SV	SA	C	O	CT-2	RR		VR-15		
I-203-4B	D-5	1	C	6	SV	SA	C	O	CT-2	RR		VR-15		
I-203-4C	C-5	1	C	6	SV	SA	C	O	CT-2	RR		VR-15		
I-203-4D	B-5	1	C	6	SV	SA	C	O	CT-2	RR		VR-15		
I-203-4E	F-8	1	C	6	SV	SA	C	O	CT-2	RR		VR-15		
I-203-4F	D-5	1	C	6	SV	SA	C	O	CT-2	RR		VR-15		
I-203-4G	C-5	1	C	6	SV	SA	C	O	CT-2	RR		VR-15		
I-203-4H	B-5	1	C	6	SV	SA	C	O	CT-2	RR		VR-15		



Commonwealth
Edison

INSERVICE TESTING PROGRAM

ISI - CLASS 1, 2, & 3 VALVES
QUAD CITIES NUCLEAR POWER STATION

UNIT - 1

SYSTEM	MAIN STEAM (CONTINUED)								P & ID	REVISION - DATE	PAGE		
									M-13 Sh. 2	2 9/17/84	27 of 36		
VALVE NUMBER	COORDINATES	CLASS	VALVE CATEGORY	VALVE SIZE	VALVE TYPE	ACTUATOR TYPE	NORMAL POSITION	STROKE DIRECTION	TEST	TEST MODE	MAX. STROKE TIME	RELIEF REQUEST	REMARKS
1-203-2A	E-7	1	A	20	GL	AO	O	C	AT-1 BTP BT FST PIT	RR OP CS CS RR	5	J-1 VR13	GROUP 1 ISOLATION
1-203-2B	E-7	1	A	20	GL	AO	O	C	AT-1 BTP BT FST PIT	RR OP CS CS RR	5	J-1 VR13	GROUP 1 ISOLATION
1-203-2C	D-7	1	A		GL	AO	O	C	AT-1 BTP BT FST PIT	RR OP CS CS RR	5	J-1 VR13	GROUP 1 ISOLATION
1-203-2D	B-7	1	A	20	GL	AO	O	C	AT-1 BTP BT FST PIT	RR OP CS CS RR	5	J-1 VR13	GROUP 1 ISOLATION
1-220-2	E-7	1	A	3	GA	MO	C	C	AT-1 BT	RR OP	35	VR13	GROUP 1 ISOLATION
1-220-17A	E-8	1	AC	0.5	XFC	SA	O	C	AT-2 CT-1	RR RR		VR-9	
1-220-17B	D-8	1	AC	0.5	XFC	SA	O	C	AT-2 CT-1	RR RR		VR-9	
1-220-17C	C-8	1	AC	0.5	XFC	SA	O	C	AT-2 CT-1	RR RR		VR-9	
1-220-17D	B-8	1	AC	0.5	XFC	SA	O	C	AT-2 CT-1	RR RR		VR-9	



Commonwealth
Edison

INSERVICE TESTING PROGRAM

ISI - CLASS 1, 2, & 3 VALVES
QUAD CITIES NUCLEAR POWER STATION

UNIT - 1

SYSTEM										P & ID		REVISION - DATE		PAGE	
MAIN STEAM (CONTINUED)										M-13 Sh. 2		2 9/17/84		28 of 36	
VALVE NUMBER	COORDINATES	CLASS	VALVE CATEGORY	VALVE SIZE	VALVE TYPE	ACTUATOR TYPE	NORMAL POSITION	STROKE DIRECTION	TEST	TEST MODE	MAX. STROKE TIME	RELIEF REQUEST	REMARKS		
1-220-18A	E-B	1	AC	.5	XFC	SA	O	C	AT-2 CT-1	RR RR		VR-9			
1-220-18B	D-B	1	AC	.5	XFC	SA	O	C	AT-2 CT-1	RR RR		VR-9			
1-220-18C	C-B	1	AC	.5	XFC	BA	O	C	AT-2 CT-1	RR RR		VR-9			
1-220-18D	B-B	1	AC	.5	XFC	SA	O	C	AT-2 CT-1	RR RR		VR-9			



Commonwealth
Edison

INSERVICE TESTING PROGRAM
ISI - CLASS 1, 2, & 3 VALVES
QUAD CITIES NUCLEAR POWER STATION

UNIT - 1

SYSTEM FEEDWATER										P & ID M-15		REVISION - DATE 2 9/17/84		PAGE 29 of 36	
VALVE NUMBER	COORDINATES	CLASS	VALVE CATEGORY	VALVE SIZE	VALVE TYPE	ACTUATOR TYPE	NORMAL POSITION	STROKE DIRECTION	TEST	TEST MODE	MAX. STROKE TIME	RELIEF REQUEST	REMARKS		
1-220-58A	E-3	1	AC	18	CK	SA	O	C	AT-1 CT-1	RR RR		VR-3			
1-220-58B	F-3	1	AC	18	CK	SA	O	O&C	AT-1 CT-1	RR RR		VR-3			
1-220-59B	F-3	2	C	18	CK	SA	O	C	CT-1	RR		VR-3			
1-220-62A	E-3	1	AC	18	CK	SA	O	C	AT-1 CT-1	RR RR		VR-3			
1-220-62B	F-3	1	AC	18	CK	SA	O	O&C	AT-1 CT-1	RR RR		VR-3			



Commonwealth
Edison

INSERVICE TESTING PROGRAM

ISI - CLASS 1, 2, & 3 VALVES
QUAD CITIES NUCLEAR POWER STATION

UNIT - 1

SYSTEM										P & ID	REVISION - - DATE	PAGE	
SERVICE WATER										M-22	2	9/17/84	30 of 36
VALVE NUMBER	COORDINATES	CLASS	VALVE CATEGORY	VALVE SIZE	VALVE TYPE	ACTUATOR TYPE	NORMAL POSITION	STROKE DIRECTION	TEST	TEST MODE	MAX. STROKE TIME	RELIEF REQUEST	REMARKS
1-3999-85	A-10	3	C	8	CK	BA	C	0	CT-1	OP			
1-3999-86	B-9	3	C	8	CK	SA	C	0	CT-1	OP			
1-3999-88	B-10	3	C	8	CK	SA	C	0	CT-1	OP			
1-3999-139	A-9	3	C	6	CK	SA	C	0	CT-1	OP			



Commonwealth
Edison

INSERVICE TESTING PROGRAM

ISI-CLASS 1, 2, & 3 VALVES
QUAD CITIES NUCLEAR POWER STATION

UNIT - 1

SYSTEM										P & ID	REVISION - DATE	PAGE	
DIESEL GENERATOR STARTING AIR (SERVICE AIR SYSTEM)										M-25	2 9/17/84	31 of 36	
VALVE NUMBER	COORDINATES	CLASS	VALVE CATEGORY	VALVE SIZE	VALVE TYPE	ACTUATOR TYPE	NORMAL POSITION	STROKE DIRECTION	TEST	TEST MODE	MAX. STROKE TIME	RELIEF REQUEST	REMARKS
1-4699-121	E-9	NC	E	1.5	GA	H	LO		NA				
1-4699-122	E-9	NC	E	1.5	GA	H	LO		NA				
1-4699-225	D-B	NC	E	1.5	BALL	H	LO		NA				
1-4699-123	E-9	NC	C	1.5	CK	SA	C	O	CT-1	OP			
1-4699-196	E-9	NC	C	1.5	CK	SA	C	O	CT-1	OP			
1-4699-226	D-B	NC	B	1.5	GL	AO	C	O	BT	OP	VR-13 VR-16		



Commonwealth
Edison

INSERVICE TESTING PROGRAM

ISI-CLASS 1, 2, & 3 VALVES
QUAD CITIES NUCLEAR POWER STATION

UNIT - 1

SYSTEM										P & ID		REVISION - DATE		PAGE	
INSTRUMENT AIR PIPING										M-24 Sh. 2		2 - 9/17/84		32 of 36	
VALVE NUMBER	COORDINATES	CLASS	VALVE CATEGORY	VALVE SIZE	VALVE TYPE	ACTUATOR TYPE	NORMAL POSITION	STROKE DIRECTION	TEST	TEST MODE	MAX. STROKE TIME	RELIEF REQUEST	REMARKS		
1-4720	D-3	NC	A	1	GA	AO	O	C	AT-1 BT FST	RR OP OP	10	VR13	GROUP 2 ISOLATION		
1-4721	D-3	NC	A	1	GA	AO	O	C	AT-1 BT FST	RR OP OP	10	VR13	GROUP 2 ISOLATION		
1-733-1	F-7	NC	A	0.375	BALL	SO	C	C	AT-1 BT	RR OP	5	VR13	GROUP 2 ISOLATION		
1-733-2	F-7	NC	A	0.375	BALL	SO	C	C	AT-1 BT	RR OP	5	VR13	GROUP 2 ISOLATION		
1-733-3	F-7	NC	A	0.375	BALL	SO	C	C	AT-1 BT	RR OP	5	VR13	GROUP 2 ISOLATION		
1-733-4	F-7	NC	A	0.375	BALL	SO	C	C	AT-1 BT	RR OP	5	VR13	GROUP 2 ISOLATION		
1-733-5	F-7	NC	A	0.375	BALL	SO	C	C	AT-1 BT	RR OP	5	VR13	GROUP 2 ISOLATION		
1-743	B-7	NC	AC	0.375	CK	SA	O	C	AT-1 CT-1	RR RR		VR-4			
1-736-1	F-7	NC	D	0.375		EXP	O	C	DT	RR					
1-736-2	F-7	NC	D	0.375		EXP	O	C	DT	RR					
1-736-3	F-7	NC	D	0.375		EXP	O	C	DT	RR					
1-736-4	F-7	NC	D	0.375		EXP	O	C	DT	RR					
1-736-5	F-7	NC	D	0.375		EXP	O	C	DT	RR					



Commonwealth
Edison

INSERVICE TESTING PROGRAM

150-CLASS 1, 2, & 3 VALVES
QUAD CITIES NUCLEAR POWER STATION

UNIT - 1

SYSTEM RX BUILDING EQUIPMENT DRAINS (& SHARED UNIT 1/2 DIESEL GEN. AIR START PIPING)										P & ID M-43		REVISION - DATE 2 9/17/84		PAGE 33 of 36
VALVE NUMBER	COORDINATES	CLASS	VALVE CATEGORY	VALVE SIZE	VALVE TYPE	ACTUATOR TYPE	NORMAL POSITION	STROKE DIRECTION	TEST	TEST MODE	MAX. STROKE TIME	RELIEF REQUEST	REMARKS	
1-2001-15	E-3	NC	A	3	GA	AO	C	C	AT-1 BT FST	RR OP OP	20	VR13	GROUP 2 ISOLATION	
1-2001-16	E-3	NC	A	3	GA	AO	C	C	AT-1 BT FST	RR OP OP	20	VR13	GROUP 2 ISOLATION	
1-2001-3	F-7	NC	A	3	GA	AO	C	C	AT-1 BT FST	RR OP OP	20	VR13	GROUP 2 ISOLATION	
1-2001-4	F-7	NC	A	3	GA	AO	C	C	AT-1 BT FST	RR OP OP	20	VR13	GROUP 2 ISOLATION	
1/2-4699-46	D-9	NC	E	1.5	GA	M	LO		NA					
1/2-4699-47	D-9	NC	E	1.5	GA	M	LO		NA					
1/2-4699-225	D-8	NC	E	1.5	BALL	M	LO		NA					
1/2-4699-48	D-9	NC	C	1.5	CK	SA	C	O	CT-1	OP				
1/2-4699-196	D-9	NC	C	1.5	CK	SA	C	O	CT-1	OP				
1/2-4699-226	D-8	NC	B	1.5	GL	AO	C	O	BT	OP	5	VR-16 VR-13		



Commonwealth
Edison

INSERVICE TESTING PROGRAM

ISI - CLASS 1, 2, & 3 VALVES
QUAD CITIES NUCLEAR POWER STATION

UNIT - 1

SYSTEM	DIESEL GENERATOR FUEL OIL (UNIT 1 AND 1/2)	P & ID	REVISION - DATE	PAGE
		M-29	2 9/17/84	34 of 36

VALVE NUMBER	COORDINATES	CLASS	VALVE CATEGORY	VALVE SIZE	VALVE TYPE	ACTUATOR TYPE	NORMAL POSITION	STROKE DIRECTION	TEST	TEST MODE	MAX. STROKE TIME	RELIEF REQUEST	REMARKS
1-5299-5	E-4	NC	C	1.5	CK	SA	C	O	CT-1	OP			
1-5201	E-3	NC	E	1	GA	SO	C	O	BT	OP	5	VR13	
1-5199-155	B-5	NC	E	1	GL	H	IO		NA				
1-5199-157	C-5	NC	C	.5	CK	SA	C	C	CT-1	OP			
1/2-5299-5	E-4	NC	C	1.5	CK	SA	C	O	CT-1	OP			
1/2-5201	E-3	NC	B	1	GA	SO	C	O	BT	OP	5	VR13	
1/2-5199-157	C-5	NC	C	.5	CK	SA	C	C	CT-1	OP			



Commonwealth
Edison

INSERVICE TESTING PROGRAM

ISI - CLASS 1, 2, & 3 VALVES
QUAD CITIES NUCLEAR POWER STATION

UNIT - 1

SYSTEM	P & ID	REVISION - DATE	PAGE										
CONTAINMENT ATMOSPHERE MONITOR	M-641 Sh. 1	2 9/17/84	35 of 36										
VALVE NUMBER	COORDINATES	CLASS	VALVE CATEGORY	VALVE SIZE	VALVE TYPE	ACTUATOR TYPE	NORMAL POSITION	STROKE DIRECTION	TEST	TEST MODE	MAX. STROKE TIME	RELIEF REQUEST	REMARKS
SO-1-2499-1A	D-7	NC	A	0.5	GA	SO	C	O	AT-1	RR			VR10, VR13
SO-1-2499-1B	D-2	NC	A	0.5	GA	SO	C	O	AT-1	RR			VR10, VR13
SO-1-2499-2A	D-6	NC	A	0.5	GA	SO	C	O	AT-1	RR			VR10, VR13
SO-1-2499-2B	D-3	NC	A	0.5	GA	SO	C	O	AT-1	RR			VR10, VR13
SO-1-2499-3A	B-7	NC	A	0.5	GA	SO	C	O	AT-1	RR			VR10, VR13
SO-1-2499-3B	B-2	NC	A	0.5	GA	SO	C	O	AT-1	RR			VR10, VR13
SO-1-2499-4A	B-6	NC	A	0.5	GA	SO	C	O	AT-1	RR			VR10, VR13
SO-1-2499-4B	B-3	NC	A	0.5	GA	SO	C	O	AT-1	RR			VR10, VR13



Commonwealth
Edison

INSERVICE TESTING PROGRAM

ISI - CLASS 1, 2, & 3 VALVES
QUAD CITIES NUCLEAR POWER STATION

UNIT - 1

SYSTEM	P & ID	REVISION - DATE	PAGE										
ATMOSPHERIC CONTAINMENT ATMOSPHERE DILUTION	M-642 Sh. 1	2 9/17/84	36 of 36										
VALVE NUMBER	COORDINATES	CLASS	VALVE CATEGORY	VALVE SIZE	VALVE TYPE	ACTUATOR TYPE	NORMAL POSITION	STROKE DIRECTION	TEST	TEST MODE	MAX. STROKE TIME	RELIEF REQUEST	REMARKS
AO-1-2599-2A	C-4	NC	A	1.0	GL	AO	C	O	AT-1	RR			VR10, VR13
AO-1-2599-2B	C-5	NC	A	1.0	GL	AO	C	O	AT-1	RR			VR10, VR13
AO-1-2599-3A	C-3	NC	A	1.0	GL	AO	C	O	AT-1	RR			VR10, VR13
AO-1-2599-3B	C-6	NC	A	1.0	GL	AO	C	O	AT-1	RR			VR10, VR13
1-2599-23A	C-3	NC	A	1.0	CK	SA	C	O	AT-1	RR			VR10, VR13
1-2599-23B	C-6	NC	A	1.0	CK	SA	C	O	AT-1	RR			VR10, VR13
1-2599-24A	C-3	NC	A	1.0	CK	SA	C	O	AT-1	RR			VR10, VR13
1-2599-24B	C-6	NC	A	1.0	CK	SA	C	O	AT-1	RR			VR10, VR13
AO-1-2599-4A	F-3	NC	A	1.0	GL	AO	C	O	AT-1	RR			VR10, VR13
AO-1-2599-4B	E-3	NC	A	1.0	GL	AO	C	O	AT-1	RR			VR10, VR13
PCV-1-2599-5A	F-4	NC	A	1.0	GL	AO	C	O	AT-1	RR			VR10, VR13
PCV-1-2599-5B	E-4	NC	A	1.0	GL	AO	C	O	AT-1	RR			VR10, VR13



Commonwealth
Edison

INSERVICE TESTING PROGRAM
ISI - CLASS 1, 2, & 3 VALVES
QUAD CITIES NUCLEAR POWER STATION

UNIT - 2

NUCLEAR BOILER INSTRUMENTATION									P & ID -M-77 Sh. 1	REVISION - DATE 2 9/17/84	PAGE 1 of 36		
VALVE NUMBER	COORDINATES	CLASS	VALVE CATEGORY	VALVE SIZE	VALVE TYPE	ACTUATOR TYPE	NORMAL POSITION	STROKE DIRECTION	TEST	TEST MODE	MAX. STROKE TIME	RELIEF REQUEST	REMARKS
2-263-2-15A	D-5	1	AC	0.5	XFC	SA	O	C	AT-2 CT-1	RR RR		VR-9	
2-263-2-13A	D-5	1	AC	0.5	XFC	SA	O	C	AT-2 CT-1	RR RR		VR-9	
2-263-2-19A	C-5	1	AC	0.5	XFC	SA	O	C	AT-2 CT-1	RR RR		VR-9	
2-263-2-17A	D-5	1	AC	0.5	XFC	SA	O	C	AT-2 CT-1	RR RR		VR-9	
2-263-2-11	E-5	1	AC	0.5	XFC	SA	O	C	AT-2 CT-1	RR RR		VR-9	
2-220-54	E-6	1	AC	0.5	XFC	SA	O	C	AT-2 CT-1	RR PR		VR-9	
2-263-2-15B	D-3	1	AC	0.5	XFC	SA	O	C	AT-2 CT-1	RR RR		VR-9	
2-263-2-13B	D-3	1	AC	0.5	XFC	SA	O	C	AT-2 CT-1	RR RR		VR-9	
2-263-2-17B	D-3	1	AC	0.5	XFC	SA	O	C	AT-2 CT-1	RR RR		VR-9	
2-263-2-19B	C-3	1	AC	0.5	XFC	SA	O	C	AT-2 CT-1	RR RR		VR-9	
2-263-2-20A	B-5	1	AC	0.5	XFC	SA	O	C	AT-2 CT-1	RR RR		VR-9	
2-263-2-23A	C-5	1	AC	0.5	XFC	SA	O	C	AT-2 CT-1	RR RR		VR-9	
2-263-2-31B	C-5	1	AC	0.5	XFC	SA	O	C	AT-2 CT-1	RR RR		VR-9	



Commonwealth
Edison

INSERVICE TESTING PROGRAM

ISI-CLASS 1, 2, & 3 VALVES
QUAD CITIES NUCLEAR POWER STATION

UNIT - 2

SYSTEM NUCLEAR BOILER INSTRUMENTATION (CONTINUED)										P & ID M-77 Sh. 1		REVISION - DATE 2 9/17/84		PAGE 2 of 36
VALVE NUMBER	COORDINATES	CLASS	VALVE CATEGORY	VALVE SIZE	VALVE TYPE	ACTUATOR TYPE	NORMAL POSITION	STROKE DIRECTION	TEST	TEST MODE	MAX. STROKE TIME	RELIEF REQUEST	REMARKS	
2-263-2-31G	C-5	1	AC	0.5	XFC	SA	O	C	AT-2 CT-1	RR RR		VR-9		
2-263-2-31C	C-5	1	AC	0.5	XFC	SA	O	C	AT-2 CT-1	RR RR		VR-9		
2-263-2-31H	C-5	1	AC	0.5	XFC	SA	O	C	AT-2 CT-1	RR RR		VR-9		
2-263-2-31D	C-5	1	AC	0.5	XFC	SA	O	C	AT-2 CT-1	RR RR		VR-9		
2-263-2-27	A-5	1	AC	0.5	XFC	SA	O	C	AT-2 CT-1	RR RR		VR-9		
2-263-2-25	B-5	1	AC	0.5	XFC	SA	O	C	AT-2 CT-1	RR RR		VR-9		
2-263-2-31J	C-5	1	AC	0.5	XFC	SA	O	C	AT-2 CT-1	RR RR		VR-9		
2-263-2-31E	C-5	1	AC	0.5	XFC	SA	O	C	AT-2 CT-1	RR RR		VR-9		
2-263-2-31K	C-5	1	AC	0.5	XFC	SA	O	C	AT-2 CT-1	RR RR		VR-9		
2-263-2-23B	C-5	1	AC	0.5	XFC	SA	O	C	AT-2 CT-1	RR RR		VR-9		
2-263-42A	C-5	1	AC	0.5	XFC	SA	O	C	AT-2 CT-1	RR RR		VR-9		
2-263-2-20B	B-5	1	AC	0.5	XFC	SA	O	C	AT-2 CT-1	RR RR		VR-9		
2-263-2-20C	B-3	1	AC	0.5	XFC	SA	O	C	AT-2 CT-1	RR RR		VR-9		



Commonwealth
Edison

INSERVICE TESTING PROGRAM

ISI - CLASS 1, 2, & 3 VALVES
QUAD CITIES NUCLEAR POWER STATION

UNIT - 2

SYSTEM NUCLEAR BOILER INSTRUMENTATION (CONTINUED)										P & ID M-77 Sh. 1		REVISION - DATE 2 - 9/27/84		PAGE 3 of 36
VALVE NUMBER	COORDINATES	CLASS	VALVE CATEGORY	VALVE SIZE	VALVE TYPE	ACTUATOR TYPE	NORMAL POSITION	STROKE DIRECTION	TEST	TEST MODE	MAX. STROKE TIME	RELIEF REQUEST	REMARKS	
2-263-2-23C	C-3	1	AC	0.5	XFC	SA	O	C	AT-2 CT-1	RR RR		VR-9		
2-263-2-31H	C-3	1	AC	0.5	XFC	SA	O	C	AT-2 CT-1	RR RR		VR-9		
2-263-2-31T	C-3	1	AC	0.5	XFC	SA	O	C	AT-2 CT-1	RR RR		VR-9		
2-263-2-31N	C-3	1	AC	0.5	XFC	SA	O	C	AT-2 CT-1	RR RR		VR-9		
2-263-2-31U	C-3	1	AC	0.5	XFC	SA	O	C	AT-2 CT-1	RR RR		VR-9		
2-263-2-31P	C-3	1	AC	0.5	XFC	SA	O	C	AT-2 CT-1	RR RR		VR-9		
2-263-2-33	B-3	1	AC	0.5	XFC	SA	O	C	AT-2 CT-1	RR RR		VR-9		
2-263-2-31V	C-3	1	AC	0.5	XFC	SA	O	C	AT-2 CT-1	RR RR		VR-9		
2-263-2-31R	C-3	1	AC	0.5	XFC	SA	O	C	AT-2 CT-1	RR RR		VR-9		
2-263-2-31W	C-3	1	AC	0.5	XFC	SA	O	C	AT-2 CT-1	RR RR		VR-9		
2-263-2-23D	C-3	1	AC	0.5	XFC	SA	O	C	AT-2 CT-1	RR RR		VR-9		
2-263-2-42H	C-3	1	AC	0.5	XFC	SA	O	C	AT-2 CT-1	RR RR		VR-9		
2-263-2-20D	B-3	1	AC	0.5	XFC	SA	O	C	AT-2 CT-1	RR RR		VR-9		



Commonwealth
Edison

INSERVICE TESTING PROGRAM

ISI - CLASS 1, 2, & 3 VALVES
QUAD CITIES NUCLEAR POWER STATION

UNIT - 2

SYSTEM										P & ID	REVISION - DATE	PAGE	
RECIRCULATION										M-77 Sh. 2	2 9/17/84	4 of 36	
VALVE NUMBER	COORDINATES	CLASS	VALVE CATEGORY	VALVE SIZE	VALVE TYPE	ACTUATOR TYPE	NORMAL POSITION	STROKE DIRECTION	TEST	TEST MODE	MAX. STROKE TIME	RELIEF REQUEST	REMARKS
2-202-5A	D-6	1	B	20	GA	HO	O	C	BT PIT	CS RR	45		J-3, VR13
2-202-5B	D-3	1	B	20	GA	HO	O	C	BT PIT	CS RR	45		J-3, VR13
2-220-44	E-5	1	A	0.75	GL	AO	O	C	AT-1 BT PIT FST	RR OP RR OP	5		VR13 GROUP 1 ISOLATION
2-220-45	E-7	1	A	0.75	GL	AO	O	C	AT-1 BT FST	RR OP OP	5		VR13 GROUP 1 ISOLATION
2-220-67A	F-5	1	AC	0.5	XFC	SA	O	C	AT-2 CT-1	RR RR			VR-9
2-220-67B	F-5	1	AC	0.5	XFC	SA	O	C	AT-2 CT-1	RR RR			VR-9
2-220-67C	E, F-5	1	AC	0.5	XFC	SA	O	C	AT-2 CT-1	RR RR			VR-9
2-220-67D	F-5	1	AC	0.5	XFC	SA	O	C	AT-2 CT-1	RR RR			VR-9
2-220-09A	E-1	1	AC	0.5	XFC	SA	O	C	AT-2 CT-1	RR RR			VR-9
2-220-09B	E-1	1	AC	0.5	XFC	SA	O	C	AT-2 CT-1	RR RR			VR-9
2-220-67E	E-5	1	AC	0.5	XFC	SA	O	C	AT-2 CT-1	RR RR			VR-9
2-220-67F	F-5	1	AC	0.5	XFC	SA	O	C	AT-2 CT-1	RR RR			VR-9



Commonwealth
Edison

INSERVICE TESTING PROGRAM

ISI - CLASS 1, 2, & 3 VALVES
QUAD CITIES NUCLEAR POWER STATION

UNIT - 2

SYSTEM	RECIRCULATION (CONTINUED)									P & ID	REVISION - DATE	PAGE	
										M-77 Sh. 2	2 9/17/84	5 of 36	
VALVE NUMBER	COORDINATES	CLASS	VALVE CATEGORY	VALVE SIZE	VALVE TYPE	ACTUATOR TYPE	NORMAL POSITION	STROKE DIRECTION	TEST	TEST MODE	MAX. STROKE TIME	RELIEF REQUEST	REMARKS
2-220-67G	E-5	1	AC	0.5	XFC	SA	O	C	AT-2 CT-1	RR RR		VR-9	
2-220-67H	F-5	1	AC	0.5	XFC	SA	O	C	AT-2 CT-1	RR RR		VR-9	
2-263-2-6A	B-7	1	AC	0.5	XFC	SA	O	C	AT-2 CT-1	RR RR		VR-9	
2-263-2-5A	B-7	1	AC	0.5	XFC	SA	O	C	AT-2 CT-1	RR RR		VR-9	
2-220-20A	B-5	1	AC	0.5	XFC	SA	O	C	AT-2 CT-1	RR RR		VR-9	
2-220-19A	B-6	1	AC	0.5	XFC	SA	O	C	AT-2 CT-1	RR RR		VR-9	
2-220-22A	D-8	1	AC	0.5	XFC	SA	O	C	AT-2 CT-1	RR RR		VR-9	
2-220-21A	D-8	1	AC	0.5	XFC	SA	O	C	AT-2 CT-1	RR RR		VR-9	
2-220-20B	A-3	1	AC	0.5	XFC	SA	O	C	AT-2 CT-1	RR RR		VR-9	
2-220-19B	A-3	1	AC	0.5	XFC	SA	O	C	AT-2 CT-1	RR RR		VR-9	
2-262-2-6B	1-2	1	AC	0.5	XFC	SA	O	C	AT-2 CT-1	RR RR		VR-9	
2-262-2-5B	B-2	1	AC	0.5	XFC	SA	O	C	AT-2 CT-1	RR RR		VR-9	
2-220-22B	D-1	1	AC	0.5	XFC	SA	O	C	AT-2 CT-1	RR RR		VR-9	



INSERVICE TESTING PROGRAM
 ISI-CLASS 1, 2, & 3 VALVES
 QUAD CITIES NUCLEAR POWER STATION

UNIT - 2

SYSTEM		REVISION - DATE		PAGE									
RECIRCULATION (CONTINUED)		2	9/17/84	6	of 36								
VALVE NUMBER	COORDINATES	CLASS	VALVE CATEGORY	VALVE SIZE	VALVE TYPE	ACTUATOR TYPE	NORMAL POSITION	STROKE DIRECTION	TEST	TEST MODE	MAX. STROKE TIME	RELIEF REQUEST	REMARKS
2-220-212	D-1	1	AC	0.5	XPC	SA	0	C	AT-2 CT-1	RR RR		VR-9	



Commonwealth
Edison

INSERVICE TESTING PROGRAM

ISI - CLASS 1, 2, & 3 VALVES
QUAD CITIES NUCLEAR POWER STATION

UNIT - 2

SYSTEM	CONTROL ROD DRIVE									P & ID	REVISION - DATE	PAGE	
										M-83 sh. 1	2 9/17/84	7 of 36	
VALVE NUMBER	COORDINATES	CLASS	VALVE CATEGORY	VALVE SIZE	VALVE TYPE	ACTUATOR TYPE	NORMAL POSITION	STROKE DIRECTION	TEST	TEST MODE	MAX. STROKE TIME	RELIEF REQUEST	REMARKS
(177) 2-0305-127	D-9	1	B	0.75	GA	AO	C	O	BT	*		VR-6	*SCRAM TESTING
(177) 2-0305-126	D-10	1	B	1.0	GA	AO	C	9	BT	*		VR-6	*SCRAM TESTING
(177) 2-0305-114	E-9	2	C	0.75	CK	SA	C	0	CT-1	*		VR-6	*SCRAM TESTING
2-0302-21A	F-6	2	B	1.0	GA	AO	O	C	BT FST	CS CS	30	VR13	
2-0302-21B	F-6	2	B	1.0	GA	AO	O	C	BT FST	CS CS	30	VR13	
2-0302-22A	F-5	2	B	2.0	GA	AO	O	C	BT FST	CS CS	30	VR13	
2-0302-21C	F-1	2	B	1.0	GA	AO	O	C	BT FST	CS CS	30	VR13	
2-0302-21D	F-1	2	B	1.0	GA	AO	O	C	BT FST	CS CS	30	VR13	
2-0302-22B	F-5	2	B	2.0	GA	AO	O	C	BT FST	CS CS	30	VR13	
2-0302-22C	F-3	2	B	2.0	GA	AO	O	C	BT FST	CS CS	30	VR13	
2-0302-22D	F-2	2	B	2.0	GA	AO	O	C	BT FST	CS CS	30	VR13	



Commonwealth
Edison

INSERVICE TESTING PROGRAM

ISI-CLASS 1, 2, & 3 VALVES
QUAD CITIES NUCLEAR POWER STATION

UNIT - 2

SYSTEM										P & ID		REVISION - DATE		PAGE	
RESIDUAL HEAT REMOVAL										M-79		2 9/17/84		8 of 36	
VALVE NUMBER	COORDINATES	CLASS	VALVE CATEGORY	VALVE SIZE	VALVE TYPE	ACTUATOR TYPE	NORMAL POSITION	STROKE DIRECTION	TEST	TEST MODE	MAX. STROKE TIME	RELIEF REQUEST	REMARKS		
2-1001-7A	B-6	2	B	14	GA	HO	O	O	BT	OP	90	VR13			
2-1001-7B	E-6	2	B	14	GA	HO	O	O	BT	OP	90	VR13			
2-1001-7C	B-6	2	B	14	GA	HO	O	O	BT	OP	90	VR13			
2-1001-7D	E-6	2	B	14	GA	HO	O	O	BT	OP	90	VR13			
2-1001-67A	B-3	2	C	12	CK	SA	C	O	CT-1	OP					
2-1001-67B	E-3	2	C	12	CK	SA	C	O	CT-1	OP					
2-1001-67C	B-9	2	C	12	CK	SA	C	O	CT-1	OP					
2-1001-67D	E-9	2	C	12	CK	SA	C	O	CT-1	OP					
2-1001-125A	B-5	2	C	1	RV	SA	C	O	CT-2	5Y					
2-1001-125B	E-5	2	C	1	RV	SA	C	O	CT-2	5Y					
2-1001-125C	B-7	2	C	1	RV	SA	C	O	CT-2	5Y					
2-1001-125D	E-7	2	C	1	RV	SA	C	O	CT-2	5Y					
2-1001-43A	B-4	2	B	14	GA	HO	C	C	BT	OP	105	VR13			
2-1001-43B	E-4	2	B	14	GA	HO	C	C	BT	OP	105	VR13			
2-1001-43C	B-8	2	B	14	GA	HO	C	C	BT	OP	105	VR13			
2-1001-43D	E-8	2	B	14	GA	HO	C	C	BT	OP	105	VR13			
2-1001-6A	F-5	2	E	24	BTF	H	LO		NA						
2-1001-6B	B-6	2	E	24	BTF	H	LO		NA						
2-1001-42A	B-5	2	E	14	GA	H	LC		NA						



Commonwealth
Edison

INSERVICE TESTING PROGRAM

ISI-CLASS 1, 2, & 3 VALVES
QUAD CITIES NUCLEAR POWER STATION

UNIT - 2

SYSTEM	RESIDUAL HEAT REMOVAL (CONTINUED)									P & ID	REVISION - DATE	PAGE	
										M-79	2 9/17/84	9 of 36	
VALVE NUMBER	COORDINATES	CLASS	VALVE CATEGORY	VALVE SIZE	VALVE TYPE	ACTUATOR TYPE	NORMAL POSITION	STROKE DIRECTION	TEST	TEST MODE	MAX. STROKE TIME	RELIEF REQUEST	REMARKS
2-1001-42B	E-5	2	E	14	GA	H	LC		NA				
2-1001-42C	C-6	2	E	14	GA	H	LC		NA				
2-1001-42D	E-6	2	E	14	GA	H	LC		NA				
2-1001-66A	B-3	2	E	12	GA	H	LO		NA				
2-1001-66B	E-3	2	E	12	GA	H	LO		NA				
2-1001-66C	B-9	2	E	12	GA	H	LO		NA				
2-1001-66D	E-9	2	E	12	GA	H	LO		NA				
2-1001-15A	B-2	2	E	18	GA	H	LO		NA				
2-1001-15B	B-9	2	E	18	GA	H	LO		NA				
2-1001-17A	A-2	2	E	18	GA	H	LO		NA				
2-1001-17B	A-10	2	E	18	GA	H	LO		NA				
2-1001-141A	B-3	2	E	2	GA	H	LO		NA				
2-1001-141B	E-3	2	E	2	GA	H	LO		NA				
2-1001-141C	B-9	2	E	2	GA	H	LO		NA				
2-1001-141D	E-9	2	E	2	GA	H	LO		NA				
2-1001-142A	B-3	2	C	2	CK	SA	C	0	CT-1	*OP			
2-1001-142B	E-3	2	C	2	CK	SA	C	0	CT-1	*OP			
2-1001-142C	B-9	2	C	2	CK	SA	C	0	CT-1	*OP			
2-1001-142D	E-9	2	C	2	CK	SA	C	0	CT-1	*OP			

*OPENSTROKE VERIFIED BY
PUMP TEST



Commonwealth
Edison

INSERVICE TESTING PROGRAM

ISI - CLASS 1, 2, & 3 VALVES
QUAD CITIES NUCLEAR POWER STATION

UNIT - 2

SYSTEM										P & ID		REVISION - DATE		PAGE	
RESIDUAL HEAT REMOVAL (CONTINUED)										M-81 sh. 1		2 9/17/84		10 of 36	
VALVE NUMBER	COORDINATES	CLASS	VALVE CATEGORY	VALVE SIZE	VALVE TYPE	ACTUATOR TYPE	NORMAL POSITION	STROKE DIRECTION	TEST	TEST MODE	MAX. STROKE TIME	RELIEF REQUEST	REMARKS		
2-1001-29A	E-6	1	A	16	GA	MO	C	D	AT-1 BT	RR CS	25	J-7, VR13			
2-1001-29B	E-8	1	A	16	GA	MO	C	O	AT-1 BT	RR CS	25	J-7, VR13			
2-1001-47	C-5	1	A	20	GA	MO	O&C	C	AT-1 BT	RR CS	40	J-4, VR13	GROUP 2 ISOLATION		
2-1001-50	D-4	1	A	20	GA	MO	O&C	C	AT-1 BT	RR CS	40	J-4, VR13	GROUP 2 ISOLATION		
2-1001-60	F-3	1	A	4	GA	MO	O&C	C	AT-1 BT	RR CS	25	J-4, VR13	GROUP 2 ISOLATION		
2-1001-63	F-4	1	A	4	GA	MO	O&C	C	AT-1 BT	RR CS	25	J-4, VR13	GROUP 2 ISOLATION		
2-1001-68A	E-5	1	C	16	CK	SA	C	O	PIT CT-1	RR CS		J-2			
2-1001-68B	E-4	1	C	16	CK	SA	C	O	PIT CT-1	RR CS		J-2			
2-1001-16A	A-7	2	B	18	GL	MO	O&C	O	BT	OP	125	VR13			
2-1001-16B	A-2	2	B	18	GL	MO	O&C	O	BT	OP	125	VR13			
2-1001-18A	C-6	2	B	3	GA	MO	C	O&C	BT	OP	17	VR13			
2-1001-18B	C-3	2	B	3	GA	MO	C	O&C	BT	OP	17	VR13			
2-1001-19A	B-8	2	B	18	GA	MO	O	O	BT	CS	125	J-6, VR13			
2-1001-19B	B-2	2	B	18	GA	MO	O	O	BT	CS	125	J-6, VR13			
2-1001-20	B-3	2	A	3	GA	MO	O&C	C	AT-1 BT	RR OP	25	VR13	GROUP 2 ISOLATION		



Commonwealth
Edison

INSERVICE TESTING PROGRAM

ISI - CLASS 1, 2, & 3 VALVES
QUAD CITIES NUCLEAR POWER STATION

UNIT - 2

SYSTEM		RESIDUAL HEAT REMOVAL (CONTINUED)										P & ID	REVISION - DATE	PAGE
												M - 01 sh. 1	2 9/17/84	11 of 36
VALVE NUMBER	COORDINATES	CLASS	VALVE CATEGORY	VALVE SIZE	VALVE TYPE	ACTUATOR TYPE	NORMAL POSITION	STROKE DIRECTION	TEST	TEST MODE	MAX. STROKE TIME	RELIEF REQUEST	REMARKS	
2-1001-21	B-3	2	A	3	GA	MO	O&C	C	AT-1 BT	RR OP	25	VR13	GROUP 2 ISOLATION	
2-1001-22A	E-8	2	C	1	RV	SA	C	O	CT-2	5Y				
2-1001-22B	E-2	2	C	1	RV	SA	C	O	CT-2	5Y				
2-1001-23A	E-6	2	A	10	GA	MO	C	C	AT-1 BT	RR OP	15	VR13		
2-1001-23B	E-3	2	A	10	GA	MO	C	C	AT-1 BT	RR OP	15	VR13		
2-1001-26A	E-5	2	A	10	GA	MO	C	C	AT-1 BT	RR OP	15	VR13		
2-1001-26B	E-4	2	A	10	GA	MO	C	C	AT-1 BT	RR OP	15	VR13		
2-1001-28A	E-6	2	B	16	GL	MO	O	O	BT	CS	90	J-7, VR13		
2-1001-28B	E-3	2	B	16	GL	MO	O	O	BT	CS	90	J-7, VR13		
2-1001-36A	E-7	2	A	14	GL	MO	C	O&C	AT-1 BT	RR OP	60	VR13		
2-1001-36B	D-3	2	A	14	GL	MO	C	O&C	AT-1 BT	RR OP	60	VR13		
2-1001-37A	E-7	2	A	6	GL	MO	C	O&C	AT-1 BT	RR OP	60	VR13		
2-1001-37B	D-3	2	A	6	GL	MO	C	O&C	AT-1 BT	RR OP	60	VR13		
2-1001-34A	E-7	2	A	16	GA	MO	C	O&C	AT-1 BT	RR OP	125	VR13		
2-1001-34B	E-3	2	A	16	GA	MO	C	O&C	AT-1 BT	RR OP	125	VR13		



Commonwealth
Edison

INSERVICE TESTING PROGRAM

ISI - CLASS 1, 2, & 3 VALVES
QUAD CITIES NUCLEAR POWER STATION

UNIT - 2

SYSTEM										P & ID	REVISION - DATE	PAGE	
RESIDUAL HEAT REMOVAL (CONTINUED)										M-81 sh. 1	2 9/17/84	12 of 36	
VALVE NUMBER	COORDINATES	CLASS	VALVE CATEGORY	VALVE SIZE	VALVE TYPE	ACTUATOR TYPE	NORMAL POSITION	STROKE DIRECTION	TEST	TEST MODE	MAX. STROKE TIME	RELIEF REQUEST	REMARKS
2-1001-33A	E-5	1	E	16	GA	H	LO		NA				
2-1001-33B	E-4	1	E	16	GA	H	LO		NA				



Commonwealth
Edison

INSERVICE TESTING PROGRAM
ISI-CLASS 1, 2, & 3 VALVES
QUAD CITIES NUCLEAR POWER STATION

UNIT - 2

SYSTEM										P & ID	REVISION - DATE		PAGE
RESIDUAL HEAT REMOVAL (CONTINUED)										M-81 sh. 2	2 9/17/84		13 of 36
VALVE NUMBER	COORDINATES	CLASS	VALVE CATEGORY	VALVE SIZE	VALVE TYPE	ACTUATOR TYPE	NORMAL POSITION	STROKE DIRECTION	TEST	TEST MODE	MAX. STROKE TIME	RELIEF REQUEST	REMARKS
2-1001-2A	D-7	3	C	12	CK	SA	C	O	CT-1	OP			
2-1001-2B	B-7	3	C	12	CK	SA	C	O	CT-1	OP			
2-1001-2C	D-2	3	C	12	CK	SA	C	O	CT-1	OP			
2-1001-2D	B-2	3	C	12	CK	SA	C	O	CT-1	OP			
2-1001-5A	E-6	3	B	12	GL	HO	C	O&C	BT	OP	90	VR13	
2-1001-5B	E-3	3	B	12	GL	HO	C	O&C	BT	OP	90	VR13	
2-1001-1A	C-6	3	E	14	GA	H	LO		NA				
2-1001-1B	B-6	3	E	14	GA	H	LO		NA				
2-1001-1C	C-3	3	E	14	GA	H	LO		NA				
2-1001-1D	B-3	3	E	14	GA	H	LO		NA				
2-1001-3A	D-7	3	E	12	GA	H	LO		NA				
2-1001-3B	B-3	3	E	12	GA	H	LO		NA				
2-1001-3C	D-2	3	E	12	GA	H	LO		NA				
2-1001-3D	B-2	3	E	12	GA	H	LO		NA				
2-1001-201A	E-6	NC	E	14	BTF	H	LO		NA				
2-1001-201B	E-3	NC	E	14	BTF	H	LO		NA				



Commonwealth
Edison

INSERVICE TESTING PROGRAM

ISI - CLASS 1, 2, & 3 VALVES
QUAD CITIES NUCLEAR POWER STATION

UNIT - 2

SYSTEM	P & ID		REVISION - DATE	PAGE									
STANDBY LIQUID CONTROL	M-82		2 9/17/84	14 of 36									
VALVE NUMBER	COORDINATES	CLASS	VALVE CATEGORY	VALVE SIZE	VALVE TYPE	ACTUATOR TYPE	NORMAL POSITION	STROKE DIRECTION	TEST	TEST MODE	MAX. STROKE TIME	RELIEF REQUEST	REMARKS
2-1101-15	C-3	1	C	1.5	CK	SA	C	O	CT-1	CS/RR		VR-5	
2-1101-16	C-3	1	C	1.5	CK	SA	C	O	CT-1	CS/RR		VR-5	
2-1106A	C-4	2	D	1.5		EXP	C	O	DT	RR			
2-1106B	D-4	2	D	1.5		EXP	C	O	DT	RR			
2-1101-43A	D-6	2	C	1.5	CK	SA	C	O	CT-1	OP			
2-1101-43B	E-5	2	C	1.5	CK	SA	C	O	CT-1	OP			
2-1105A	C-6	2	C	1.5	RV	SA	C	O	CT-2	5Y			
2-1105B	D-5	2	C	1.5	RV	SA	C	O	CT-2	5Y			
2-1101-4	E-B	2	E	2.5	GA	H	LO		NA				
2-1101-B	D-B	2	E	2.5	GA	H	LC		NA				
2-1101-3A	D-7	2	E	2.5	GA	H	LO		NA				
2-1101-3B	J-7	2	E	2.5	GA	H	LO		NA				
2-1101-10	D-7	2	E	1	GL	H	LC		NA				
2-1101-2A	D-5	2	E	1.5	GL	H	LO		NA				
2-1101-2B	E-5	2	E	1.5	GL	H	LO		NA				
2-1101-22	C-4	2	E	1.5	GL	H	LC		NA				
2-1101-9B	D-4	2	E	1	GL	H	LC		NA				
2-1101-23	D-3	2	E	1.5	GL	H	LO		NA				
2-1101-1	D-2	1	E	1.5	GL	H	LO		NA				



Commonwealth
Edison

INSERVICE TESTING PROGRAM
ISI - CLASS 1, 2, & 3 VALVES
QUAD CITIES NUCLEAR POWER STATION

UNIT - 2

SYSTEM		P & ID		REVISION - DATE		PAGE							
RX WATER CLEAN-UP		M-88		2 9/17/84		15 of 36							
VALVE NUMBER	COORDINATES	CLASS	VALVE CATEGORY	VALVE SIZE	VALVE TYPE	ACTUATOR TYPE	NORMAL POSITION	STROKE DIRECTION	TEST	TEST MODE	MAX. STROKE TIME	RELIEF REQUEST	REMARKS
2-1201-2	B-6	1	A	6	GA	MO	O	C	AT-1 HT PIT	RR OP RR	30	VR13	GROUP 3 ISOLATION
2-1201-5	B-6	1	A	6	GA	MO	O	C	AT-1 BT	RR OP	30	VR13	GROUP 3 ISOLATION



Commonwealth
Edison

INSERVICE TESTING PROGRAM

ISI - CLASS 1, 2, & 3 VALVES
QUAD CITIES NUCLEAR POWER STATION

UNIT - 2

SYSTEM	REACTOR CORE ISOLATION COOLING								P & ID	REVISION - DATE	PAGE		
									M-89	2 9/17/84	16 of 36		
VALVE NUMBER	COORDINATES	CLASS	VALVE CATEGORY	VALVE SIZE	VALVE TYPE	ACTUATOR TYPE	NORMAL POSITION	STROKE DIRECTION	TEST	TEST MODE	MAX. STROKE TIME	RELIEF REQUEST	REMARKS
2-1301-16	B-2	1	A	3	GA	MO	O	C	AT-1 BT PIT	RR OP RR	25	VR13	GROUP 5 ISOLATION
2-1301-17	B-3	1	A	3	GA	MO	O	C	AT-1 BT	RR OP	25	VR13	GROUP 5 ISOLATION
2-1301-40	D-2	NC	AC	2	CK	SA	C	C	AT-1 CT-1	RR RR		VR-B	
2-1301-41	D-2	NC	AC	8	CK	SA	C	C	AT-1 CT-1	RR RR		VR-B	
2-1301-15A	B-2	1	AC	.5	XFC	SA	O	C	AT-2 CT-1	RR RR		VR-9	
2-1301-15B	B-2	1	AC	.5	XFC	SA	O	C	AT-2 CT-1	RR RR		VR-9	



Commonwealth
Edison

INSERVICE TESTING PROGRAM

ISI - CLASS 1, 2, & 3 VALVES
QUAD CITIES NUCLEAR POWER STATION

UNIT - 2

SYSTEM									P & ID		REVISION - DATE		PAGE
CORE SPRAY									M - 7B		2 9/17/84		17 of 36
VALVE NUMBER	COORDINATES	CLASS	VALVE CATEGORY	VALVE SIZE	VALVE TYPE	ACTUATOR TYPE	NORMAL POSITION	STROKE DIRECTION	TEST	TEST MODE	MAX. STROKE TIME	RELIEF REQUEST	REMARKS
2-1402-9A	C-3	1	C	10	CK	SA	C	O	CT-1 PIT	CS RR		J-2	
2-1402-9B	C-4	1	C	10	CK	SA	C	O	CT-1 PIT	CS RR		J-2	
2-1402-25A	C-2	1	B	10	GA	HO	C	O	BT	OP	15	VR13	
2-1402-25B	C-5	1	B	10	GA	HO	C	O	BT	OP	15	VR13	
2-1402-24A	B-2	2	B	10	GA	HO	O	O	BT	OP	15	VR13	
2-1402-24B	B-5	2	B	10	GA	HO	O	O	BT	OP	15	VR13	
2-1402-28A	C-9	2	C	2	RV	SA	C	O	CT-2	SY			
2-1402-28B	D-6	2	C	2	RV	SA	C	O	CT-2	SY			
2-1402-38A	C-8	2	B	1.5	GA	HO	O	C	BT	OP	12	VR13	
2-1402-38B	D-7	2	B	1.5	GA	HO	O	C	BT	OP	12	VR13	
2-1402-8A	E-9	2	CE	12	SCK	SA	C/LC	O	CT-1	OP			
2-1402-8B	E-6	2	CE	12	SCK	SA	C/LO	O	CT-1	OP			
2-1402-31A	D-3	1	AC	.5	XPC	SA	O	C	AT-2 CT-1	RR RR		VR-9	
2-1402-31B	D-4	1	AC	.5	XPC	SA	O	C	AT-2 CT-1	RR RR		VR-9	
2-1402-6A	D-3	1	E	10	GA	H	LO		NA				
2-1402-6B	D-3	1	E	10	GA	H	LO		NA				
2-1402-2A	G-7	2	E	12	GA	H	LC		NA				



Commonwealth
Edison

INSERVICE TESTING PROGRAM

ISI-CLASS 1, 2, & 3 VALVES
QUAD CITIES NUCLEAR POWER STATION

UNIT - 2

SYSTEM										P & ID		REVISION - DATE		PAGE	
CORE SPRAY (CONTINUED)										M-78		2 9/17/84		18 of 36	
VALVE NUMBER	COORDINATES	CLASS	VALVE CATEGORY	VALVE SIZE	VALVE TYPE	ACTUATOR TYPE	NORMAL POSITION	STROKE DIRECTION	TEST	TEST MODE	MAX. STROKE TIME	RELIEF REQUEST	REMARKS		
2-1402-2B	G-4	2	E	12	GA	H	LC		NA						
2-1402-34A	G-4	2	E	18	BTF	H	LO		NA						
2-1402-34B	F-3	2	E	18	BTF	H	LO		NA						
2-1402-4A	A-8	2	B	8	GL	MO	C	C	BT	OP	60	VR-13			
2-1402-4B	C-7	2	B	8	GL	MO	C	C	BT	OP	60	VR-13			
2-1402-13A	E-9	2	CE	1.5	SCK	SA/H	C/LO	O	CT-1	*OP					
2-1402-13B	E-6	2	CE	1.5	SCK	SA/H	C/LO	O	CT-1	*OP					
													*OPEN STROKE VERIFIED BY PUMP TEST		



Commonwealth
Edison

INSERVICE TESTING PROGRAM

ISI - CLASS 1, 2, & 3 VALVES
QUAD CITIES NUCLEAR POWER STATION

UNIT - 2

SYSTEM	PRESSURE SUPPRESSION										P & ID	REVISION - DATE	PAGE
											M-76	2 9/17/84	19 of 36
VALVE NUMBER	COORDINATES	CLASS	VALVE CATEGORY	VALVE SIZE	VALVE TYPE	ACTUATOR TYPE	NORMAL POSITION	STROKE DIRECTION	TEST	TEST MODE	MAX. STROKE TIME	RELIEF REQUEST	REMARKS
2-1601-21	C-6	NC	A	18	BTP	AO	C	C	AT-1 BT FST	RR OP OP	10	VR13	GROUP 2 ISOLATION
2-1601-22	C-6	NC	A	18	BTP	AO	C	C	AT-1 BT FST	RR OP OP	10	VR13	GROUP 2 ISOLATION
2-1601-55	A-6	NC	A	4	GA	AO	O	C	AT-1 BT FST	RR OP OP	10	VR13	GROUP 2 ISOLATION
2-1601-56	D-6	NC	A	18	BTP	AO	O	C	AT-1 BT FST	RR OP OP	10	VR13	GROUP 2 ISOLATION
2-1601-57	C-9	NC	A	1	GL	MO	O	C	AT-1 BT FST	RR OP OP	15	VR13	GROUP 2 ISOLATION
2-1601-58	D-7	NC	A	1	GL	AO	C	C	AT-1 BT FST	RR OP OP	15	VR13	GROUP 2 ISOLATION
2-1601-59	D-7	NC	A	1	GL	AO	O	C	AT-1 BT FST	RR OP OP	15	VR13	GROUP 2 ISOLATION
2-1601-20A	D-9	NC	A	20	BTP	AO	C	O&C	AT-1 BT FST	RR CS OP	10	J-8, VR13	
2-1601-31A	D-9	NC	AC	20	CK	SA	C	O&C	AT-1 CT-1	RR OP			
2-1601-20B	E-9	NC	A	20	BTP	AO	C	O&C	AT-1 BT FST	RR CS OP	10	J-8, VR13	



Commonwealth
Edison

INSERVICE TESTING PROGRAM

ISI - CLASS 1, 2, & 3 VALVES
QUAD CITIES NUCLEAR POWER STATION

UNIT - 2

SYSTEM	PRESSURE SUPPRESSION (CONTINUED)									P & ID	REVISION - DATE	PAGE	
										M-76	2 9/17/84	20 of 36	
VALVE NUMBER	COORDINATES	CLASS	VALVE CATEGORY	VALVE SIZE	VALVE TYPE	ACTUATOR TYPE	NORMAL POSITION	STROKE DIRECTION	TEST	TEST MODE	MAX. STROKE TIME	RELIEF REQUEST	REMARKS
2-1601-31B	E-9	NC	AC	20	CK	SA	C	O&C	AT-1 CT-1	RR OP			
2-1601-23	B-3	NC	A	18	BTF	AO	C	C	AT-1 BT FST	RR OP OP	10	VR13	GROUP 2 ISOLATION
2-1601-24	D-2	NC	A	18	BTF	AO	C	C	AT-1 BT FST	RR OP OP	10	VR13	GROUP 2 ISOLATION
2-1601-60	E-2	NC	A	18	BTF	AO	C	C	AT-1 BT FST	RR OP OP	10	VR13	GROUP 2 ISOLATION
2-1601-61	F-2	NC	A	2	GL	AO	C	C	AT-1 BT FST	RR OP OP	15	VR13	GROUP 2 ISOLATION
2-1601-62	B-2	NC	A	2	GL	AO	C	C	AT-1 BT FST	RR OP OP	15	VR13	GROUP 2 ISOLATION
2-1601-63	A-2	NC	A	6	BTF	AO	C	C	AT-1 BT FST	RR OP OP	10	VR13	GROUP 2 ISOLATION
2-8803	C-6	NC	A	2	GL	AO	O	O	AT-1 BT FST	RR OP OP	10	VR13	GROUP 2 ISOLATION
2-8804	D-6	NC	A	2	GL	AO	O	C	AT-1 BT FST	RR OP OP	10	VR13	GROUP 2 ISOLATION
2-8801A	C-3	NC	A	0.5	GL	AO	O	C	AT-1 BT FST	RR OP OP	10	VR13	GROUP 2 ISOLATION



Commonwealth
Edison

INSERVICE TESTING PROGRAM

ISI - CLASS 1, 2, & 3 VALVES
QUAD CITIES NUCLEAR POWER STATION

UNIT - 2

SYSTEM PRESSURE SUPPRESSION (CONTINUED)										P & ID M-76		REVISION - DATE 2 9/17/84		PAGE 21 of 36
VALVE NUMBER	COORDINATES	CLASS	VALVE CATEGORY	VALVE SIZE	VALVE TYPE	ACTUATOR TYPE	NORMAL POSITION	STROKE DIRECTION	TEST	TEST MODE	MAX. STROKE TIME	RELIEF REQUEST	REMARKS	
2-8801B	D-3	NC	A	0.5	GL	AO	O	C	AT-1 BT FST	RR OP OP	10	VR13	GROUP 2 ISOLATION	
2-8801C	D-3	NC	A	0.5	GL	AO	O	C	AT-1 BT FST	RR OP OP	10	VR13	GROUP 2 ISOLATION	
2-8801D	E-3	NC	A	0.5	GL	AO	O	C	AT-1 BT FST	RR OP OP	10	VR13	GROUP 2 ISOLATION	
2-8802A	C-3	NC	A	0.5	GL	AO	O	C	AT-1 BT FST	RR OP OP	10	VR13	GROUP 2 ISOLATION	
2-8802B	D-3	NC	A	0.5	GL	AO	O	C	AT-1 BT FST	RR OP OP	10	VR13	GROUP 2 ISOLATION	
2-8802C	D-3	NC	A	0.5	GL	AO	O	C	AT-1 BT FST	RR OP OP	10	VR13	GROUP 2 ISOLATION	
2-8802D	E-3	NC	A	0.5	GL	AO	O	C	AT-1 BT FST	RR OP OP	10	VR13	GROUP 2 ISOLATION	
2-1601-32A	E-2	NC	C	18	CK	SA	C	O&C	CT-1	OP				
2-1601-32B	E-2	NC	C	18	CK	SA	C	O&C	CT-1	OP				
2-1601-32C	E-2	NC	C	18	CK	SA	C	O&C	CT-1	OP				
2-1601-32D	E-2	NC	C	18	CK	SA	C	O&C	CT-1	OP				
2-1601-32E	E-2	NC	C	18	CK	SA	C	O&C	CT-1	OP				



Commonwealth
Edison

INSERVICE TESTING PROGRAM

ISI - CLASS 1, 2, & 3 VALVES
QUAD CITIES NUCLEAR POWER STATION

UNIT - 2

SYSTEM	PRESSURE SUPPRESSION (CONTINUED)									P & ID	REVISION - DATE	PAGE	
										M-76 sh. 1	2 9/17/84	22 of 36	
VALVE NUMBER	COORDINATES	CLASS	VALVE CATEGORY	VALVE SIZE	VALVE TYPE	ACTUATOR TYPE	NORMAL POSITION	STROKE DIRECTION	TEST	TEST MODE	MAX. STROKE TIME	RELIEF REQUEST	REMARKS
2-1601-32P	E-2	NC	C	18	CK	SA	C	O&C	CT-1	OP			
2-1601-33A	E-7	NC	C	18	CK	SA	C	O&C	CT-1	OP			
2-1601-33B	E-7	NC	C	18	CK	SA	C	O&C	CT-1	OP			
2-1601-33C	E-7	NC	C	18	CK	SA	C	O&C	CT-1	OP			
2-1601-33D	E-7	NC	C	18	CK	SA	C	O&C	CT-1	OP			
2-1601-33E	E-7	NC	C	18	CK	SA	C	O&C	CT-1	OP			
2-1601-33F	E-7	NC	C	18	CK	SA	C	O&C	CT-1	OP			
2-220-B1A	E-4	NC	C	1	CK	SA	C	O	CT-1	CS			VR-14
2-220-B1B	E-4	NC	C	1	CK	SA	C	O	CT-1	CS			VR-14
2-220-B1C	E-4	NC	C	1	CK	SA	C	O	CT-1	CS			VR-14
2-220-B1D	E-5	NC	C	1	CK	SA	C	O	CT-1	CS			VR-14
2-220-B1E	E-5	NC	C	1	CK	SA	C	O	CT-1	CS			VR-14
2-220-105A	D-4	NC	C	8	CK	SA	C	O	CT-1	CS			VR-14
2-220-105B	E-5	NC	C	8	CK	SA	C	O	CT-1	CS			VR-14
2-220-105C	E-5	NC	C	8	CK	SA	C	O	CT-1	CS			VR-14
2-220-105D	D-5	NC	C	8	CK	SA	C	O	CT-1	CS			VR-14
2-220-105E	C-5	NC	C	8	CK	SA	C	O	CT-1	CS			VR-14



INSERVICE TESTING PROGRAM

ISI-CLASS 1, 2, & 3 VALVES
QUAD CITIES NUCLEAR POWER STATION

UNIT - 2

SYSTEM	P & ID	REVISION - DATE	PAGE										
HIGH PRESSURE COOLANT INJECTION	M-87	2 9/17/84	23 of 36										
VALVE NUMBER	COORDINATES	CLASS	VALVE CATEGORY	VALVE SIZE	VALVE TYPE	ACTUATOR TYPE	NORMAL POSITION	STROKE DIRECTION	TEST	TEST MODE	MAX. STROKE TIME	RELIEF REQUEST	REMARKS
2-2301-4	C-9	1	A	10	GA	MO	O	O&C	AT-1 BT PIT	RR CS RR	50	J-5, VR13	GROUP 4 ISOLATION
2-2301-5	B-10	1	A	10	GA	MO	O	O&C	AT-1 BT	RR CS	50	J-5, VR13	GROUP 4 ISOLATION
2-2301-3	A-6	2	B	10	GA	MO	C	O	BT	OP	25	VR13	
2-2301-68	A-6	2	D	16	RPD	SA	C	O	*	*			*PER MANUFACTURER RECOMMENDATION
2-2301-69	A-E	2	D	16	RPD	SA	C	O	*	*			*PER MANUFACTURER RECOMMENDATION
2-2301-29	B-9	2	B	1	GL	AO	O	C	BT FST	OP OP	10	VR13	
2-2301-34	D-7	2	AC	2	CK	SA	C	O&C	AT-1 CT-1	RR OP/RR*		VR-8	*VERIFIED OPEN DURING PUMP TEST
2-2301-45	B-B	2	AC	24	CK	SA	C	O&C	AT-1 CT-1	RR OP/RR*		VR-8	*VERIFIED OPEN DURING PUMP TEST
2-2301-35	E-7	2	B	16	GA	MO	C	O&C	BT	OP	120	VR13	
2-2301-36	E-9	2	B	16	GA	MO	C	O&C	BT	OP	120	VR13	
2-2301-6	F-2	2	B	16	GA	MO	O	O&C	BT	OP	120	VR13	
2-2301-20	E-2	2	C	16	CK	SA	O	O	CT-1	OP			
2-2301-14	C-6	2	B	4	GL	MO	C	O&C	BT	OP	26	VR13	
2-2301-39	E-8	2	C	16	CK	SA	C	O	CT-1	*		VR-7	*SEE VR-7
2-2301-40	D-7	NC	C	4	CK	SA	C	O	CT-1	OP**			

**OPEN STROKE VERIFIED BY PUMP TEST



Commonwealth
Edison

INSERVICE TESTING PROGRAM

ISI - CLASS 1, 2, & 3 VALVES
QUAD CITIES NUCLEAR POWER STATION

UNIT - 2

SYSTEM	P & ID	REVISION - DATE	PAGE										
HIGH PRESSURE COOLANT INJECTION (CONTINUED)	M.-87	2 9/17/84	24 of 36										
VALVE NUMBER	COORDINATES	CLASS	VALVE CATEGORY	VALVE SIZE	VALVE TYPE	ACTUATOR TYPE	NORMAL POSITION	STROKE DIRECTION	TEST	TEST MODE	MAX. STROKE TIME	RELIEF REQUEST	REMARKS
2-2301-8	D-6	2	B	14	GA	MO	C	O	BT	OP	45	VR13	
2-2301-7	D-6	2	C	14	CK	SA	C	O	PIT CT-1	RR CS		J-2	
2-2301-74	B-8	2	CE	12	SCK	SA	C/LO	O	CT-1	OP*			*VERIFIED OPEN DURING PUMP TEST
2-2301-26	D-9	1	AC	.5	XFC	SA	O	C	AT-2 CT-1	RR RR		VR-9	
2-2301-27	D-9	1	AC	.5	XFC	SA	O	C	AT-2 CT-1	RR RR		VR-9	
2-2301-22	B-1	2	E	16	GA	M	LO			NA			
2-2301-56	F-8	2	E	16	BTF	M	LO			NA			
2-2301-71	D-7	2	CE	2	SCK	SA/M	C/LO	O	CT-1	OP*			*VERIFIED OPEN DURING PUMP TEST
2-2301-9	D-5	2	D	14	GA	MO	O	O	BT	OP	45	VR13	
2-2301-10	E-5	2	B	12	GL	MO	C	C	BT	OP	60	VR13	



Commonwealth
Edison

INSERVICE TESTING PROGRAM

ISI - CLASS 1, 2, & 3 VALVES
QUAD CITIES NUCLEAR POWER STATION

UNIT - 2

SYSTEM	MAIN STEAM								P & ID	REVISION - DATE	PAGE		
									M -60 Sh. 1	2 9/17/84	25 of 36		
VALVE NUMBER	COORDINATES	CLASS	VALVE CATEGORY	VALVE SIZE	VALVE TYPE	ACTUATOR TYPE	NORMAL POSITION	STROKE DIRECTION	TEST	TEST MODE	MAX. STROKE TIME	RELIEF REQUEST	REMARKS
2-203-1A	P-4	1	A	20	GL	AO	O	C	AT-1 BTP BT FST PIT	RR OP CS CS RR	5	J-1 VR13	GROUP 1 ISOLATION
2-203-1B	D-4	1	A	20	GL	AO	O	O	AT-1 BTP BT FST PIT	RR OP CS CS RR	5	J-1 VR13	GROUP 1 ISOLATION
2-203-1C	C-4	1	A	20	GL	AO	O	C	AT-1 BTP BT FST PIT	RR OP CS CS RR	5	J-1 VR13	GROUP 1 ISOLATION
2-203-1D	B-4	1	A	20	GL	AO	O	C	AT-1 BTP BT FST PIT	RR OP CS CS RR	5	J-1 VR13	GROUP 1 ISOLATION
2-220-1	E-4	1	A	3	GA	MO	C	C	AT-1 BT	RR OP	35	VR13	GROUP 1 ISOLATION
2-203-3A	P-4	1	BC	6	ERV/SV	PS/SA	C	C	BT CT-2	I RR	I	VR-1 VR-2	*SEE VR-1
2-203-3B	D-6	1	BC	6	ERV	PS	C	O	BT CT-2	* RR	*	VR-1 VR-2	*SEE VR-1
2-203-3C	C-7	1	BC	6	ERV	PS	C	O	BT CT-2	* RR	*	VR-1 VR-2	*SEE VR-1
2-203-3D	B-7	1	BC	6	ERV	PS	C	O	BT CT-2	* RR	*	VR-1 VR-2	*SEE VR-1



Commonwealth
Edison

INSERVICE TESTING PROGRAM

ISI - CLASS 1, 2, & 3 VALVES
QUAD CITIES NUCLEAR POWER STATION

UNIT - 2

SYSTEM										P & ID		REVISION - DATE		PAGE	
MAIN STEAM (CONTINUED)										M -60 Sh. 1		2 9/17/84		26 of 36	
VALVE NUMBER	COORDINATES	CLASS	VALVE CATEGORY	VALVE SIZE	VALVE TYPE	ACTUATOR TYPE	NORMAL POSITION	STROKE DIRECTION	TEST	TEST MODE	MAX. STROKE TIME	RELIEF REQUEST	REMARKS		
2-203-3E	D-7	1	BC	6	ERV	PS	C	O	BT CT-2	* RR	*	VR-1 VR-2	*SEE VR-1		
2-203-4A	F-8	1	C	6	SV	SA	C	O	CT-2	RR		VR-15			
2-203-4B	D-5	1	C	6	SV	SA	C	O	CT-2	RR		VR-15			
2-203-4C	C-5	1	C	6	SV	SA	C	O	CT-2	RR		VR-15			
2-203-4D	B-5	1	C	6	SV	SA	C	O	CT-2	RR		VR-15			
2-203-4E	F-8	1	C	6	SV	SA	C	O	CT-2	RR		VR-15			
2-203-4F	D-5	1	C	6	SV	SA	C	O	CT-2	EE		VR-15			
2-203-4G	C-5	1	C	6	SV	SA	C	O	CT-2	RR		VR-15			
2-203-4H	B-5	1	C	6	SV	SA	C	O	CT-2	RR		VR-15			



Commonwealth
Edison

INSERVICE TESTING PROGRAM

ISI-CLASS 1, 2, & 3 VALVES
QUAD CITIES NUCLEAR POWER STATION

UNIT - 2

SYSTEM									P & ID		REVISION - DATE		PAGE
MAIN STEAM (CONTINUED)									M-60 Sh. 2		2 9/17/84		27 of 36
VALVE NUMBER	COORDINATES	CLASS	VALVE CATEGORY	VALVE SIZE	VALVE TYPE	ACTUATOR TYPE	NORMAL POSITION	STROKE DIRECTION	TEST	TEST MODE	MAX. STROKE TIME	RELIEF REQUEST	REMARKS
2-203-2A	E-7	1	A	20	GL	AO	O	C	AT-1 BTP BT FST PIT	RR OP CS CS RR	5	J-1 VR13	GROUP 1 ISOLATION
2-203-2B	E-7	1	A	20	GL	AO	Q	C	AT-1 BTP BT FST PIT	RR OP CS CS RR	5	J-1 VR13	GROUP 1 ISOLATION
2-203-2C	D-7	1	A	20	GL	AO	O	C	AT-1 BTP BT FST PIT	RR OP CS CS RR	5	J-1 VR13	GROUP 1 ISOLATION
2-203-2D	D-7	1	A	20	GL	AO	O	C	AT-1 BTP BT FST PIT	RR OP CS CS RR	5	J-1 VR13	GROUP 1 ISOLATION
2-220-2	E-7	1	A	3	GA	MO	C	C	AT-1 BT	RR OP	35	VR13	GROUP 1 ISOLATION
2-220-17A	E-B	1	AC	0.5	XFC	SA	O	C	AT-2 CT-1	RR RR		VR-9	
2-220-17B	D-B	1	AC	0.5	XFC	SA	O	C	AT-2 CT-1	RR RR		VR-9	
2-220-17C	C-B	1	AC	0.5	XFC	SA	O	C	AT-2 CT-1	RR RR		VR-9	
2-220-17D	H-B	1	AC	0.5	XFC	SA	O	C	AT-2 CT-1	RR RR		VR-9	



Commonwealth
Edison

INSERVICE TESTING PROGRAM

ISI - CLASS 1, 2, & 3 VALVES
QUAD CITIES NUCLEAR POWER STATION

UNIT - 2

SYSTEM										P & ID		REVISION - DATE		PAGE	
MAIN STEAM (CONTINUED)										M-60 Sh. 2		2 9/17/84		28 OF 36	
VALVE NUMBER	COORDINATES	CLASS	VALVE CATEGORY	VALVE SIZE	VALVE TYPE	ACTUATOR TYPE	NORMAL POSITION	STROKE DIRECTION	TEST	TEST MODE	MAX. STROKE TIME	RELIEF REQUEST	REMARKS		
2-220-10A	E-B	1	AC	.5	PC	SA	O	C	AT-2 CT-1	RR RR		VR-9			
2-220-10B	D-B	1	AC	.5	XPC	SA	O	C	AT-2 CT-1	RR RR		VR-9			
2-220-10C	C-B	1	AC	.5	XPC	SA	O	C	AT-2 CT-1	RR RR		VR-9			
2-220-10D	B-B	1	AC	.5	XPC	SA	O	C	AT-2 CT-1	RR RR		VR-9			



Commonwealth
Edison

INSERVICE TESTING PROGRAM
ISI - CLASS 1, 2, & 3 VALVES
QUAD CITIES NUCLEAR POWER STATION

UNIT - 2

SYSTEM										P & ID		REVISION - DATE		PAGE	
FEEDWATER										M-62		2 - 9/17/84		29 of 36	
VALVE NUMBER	COORDINATES	CLASS	VALVE CATEGORY	VALVE SIZE	VALVE TYPE	ACTUATOR TYPE	NORMAL POSITION	STROKE DIRECTION	TEST	TEST MODE	MAX. STROKE TIME	RELIEF REQUEST	REMARKS		
2-220-58A	E-3	1	AC	18	CK	SA	O	C	AT-1 CT-1	RR RR		VR-3			
2-220-58B	F-3	1	AC	18	CK	SA	O	O&C	AT-1 CT-1	RR RR		VR-3			
2-220-59B	F-3	2	C	18	CK	SA	O	C	CT-1	RR		VR-3			
2-220-62A	E-3	1	AC	18	CK	SA	O	C	AT-1 CT-1	RR RR		VR-3			
2-220-62B	F-3	1	AC	18	CK	SA	O	O&C	AT-1 CT-1	RR RR		VR-3			



Commonwealth
Edison

INSERVICE TESTING PROGRAM

ISI - CLASS 1, 2, & 3 VALVES
QUAD CITIES NUCLEAR POWER STATION

UNIT - 2

SYSTEM										P & ID	REVISION - DATE		PAGE
SERVICE WATER										M-69	2 9/17/84		30 of 36
VALVE NUMBER	COORDINATES	CLASS	VALVE CATEGORY	VALVE SIZE	VALVE TYPE	ACTUATOR TYPE	NORMAL POSITION	STROKE DIRECTION	TEST	TEST MODE	MAX. STROKE TIME	RELIEF REQUEST	REMARKS
2-3999-86	B-9	3	C	8	CK	SA	C	0	CT-1	OP			
2-3999-88	B-10	3	C	8	CK	SA	C	0	CT-1	OP			
2-3999-139	A-9	3	C	6	CK	SA	C	0	CT-1	OP			



Commonwealth
Edison

INSERVICE TESTING PROGRAM

ISI-CLASS 1, 2, & 3 VALVES
QUAD CITIES NUCLEAR POWER STATION

UNIT - 2

SYSTEM	P & ID	REVISION - DATE	PAGE										
DIESEL GENERATOR STARTING AIR (SERVICE AIR SYSTEM)	M-72	2 9/17/84	31 of 36										
VALVE NUMBER	COORDINATES	CLASS	VALVE CATEGORY	VALVE SIZE	VALVE TYPE	ACTUATOR TYPE	NORMAL POSITION	STROKE DIRECTION	TEST	TEST MODE	MAX. STROKE TIME	RELIEF REQUEST	REMARKS
2-4699-121	E-9	NC	E	1.5	GA	H	LO		NA				
2-4699-122	E-9	NC	E	1.5	GA	H	LO		NA				
2-4699-225	D-8	NC	E	1.5	BALL	H	LO		NA				
2-4699-123	E-9	NC	C	1.5	CK	SA	C	O	CT-1	OP			
2-4699-196	E-9	NC	C	1.5	CK	SA	C	O	CT-1	OP			
2-4699-226	D-8	NC	B	1.5	GL	AO	C	O	BT	OP		VR13 VR16	



Commonwealth
Edison

INSERVICE TESTING PROGRAM

ISI - CLASS 1, 2, & 3 VALVES
QUAD CITIES NUCLEAR POWER STATION

UNIT - 2

SYSTEM	P & ID		REVISION - DATE	PAGE									
INSTRUMENT AIR PIPING	M-71 Sh. 2		2 9/17/84	32 of 36									
VALVE NUMBER	COORDINATES	CLASS	VALVE CATEGORY	VALVE SIZE	VALVE TYPE	ACTUATOR TYPE	NORMAL POSITION	STROKE DIRECTION	TEST	TEST MODE	MAX. STROKE TIME	RELIEF REQUEST	REMARKS
2-4720	D-3	NC	A	1	GA	AO	O	C	AT-1 BT FST	RR OP OP	10	VR13	GROUP 2 ISOLATION
2-4721	D-3	NC	A	1	GA	AO	O	C	AT-1 BT FST	RR OP OP	10	VR13	GROUP 2 ISOLATION
2-733-1	F-7	NC	A	0.375	BALL	SO	C	C	AT-1 BT	RR OP	5	VR13	GROUP 2 ISOLATION
2-733-2	F-7	NC	A	0.375	BALL	SO	C	C	AT-1 BT	RR OP	5	VR13	GROUP 2 ISOLATION
2-733-3	F-7	NC	A	0.375	BALL	SO	C	C	AT-1 BT	RR OP	5	VR13	GROUP 2 ISOLATION
2-733-4	F-7	NC	A	0.375	BALL	SO	C	C	AT-1 BT	RR OP	5	VR13	GROUP 2 ISOLATION
2-733-5	F-7	NC	A	0.375	BALL	SO	C	C	AT-1 BT	RR OP	5	VR13	GROUP 2 ISOLATION
2-743	B-7	NC	AC	0.375	CK	SA	O	C	AT-1 CT-1	RR RR		VR-4	
2-736-1	F-7	NC	D	0.375		EXP	O	C	DT	RR			
2-736-2	F-7	NC	D	0.375		EXP	O	C	DT	RR			
2-736-3	F-7	NC	D	0.375		EXP	O	C	DT	RR			
2-736-4	F-7	NC	D	0.375		EXP	O	C	DT	RR			
2-736-5	F-7	NC	D	0.375		EXP	O	C	DT	RR			



Commonwealth
Edison

INSERVICE TESTING PROGRAM
ISI - CLASS 1, 2, & 3 VALVES
QUAD CITIES NUCLEAR POWER STATION

UNIT - 2

SYSTEM										P & ID	REVISION - DATE	PAGE	
DIESEL GENERATOR FUEL OIL										M-29	2 9/17/84	34 of 36	
VALVE NUMBER	COORDINATES	CLASS	VALVE CATEGORY	VALVE SIZE	VALVE TYPE	ACTUATOR TYPE	NORMAL POSITION	STROKE DIRECTION	TEST	TEST MODE	MAX. STROKE TIME	RELIEF REQUEST	REMARKS
2-5299-5	E-4	NC	C	1.5	CK	SA	C	O	CT-1	OP			
2-5201	E-3	NC	B	1	GA	SO	C	O	BT	OP	5	VR13	
2-5199-155	B-5	NC	E	1	GL	H	LO		NA				
2-5199-157	C-5	NC	C	.5	CK	SA	C	C	CT-1	OP			



Commonwealth
Edison

INSERVICE TESTING PROGRAM
ISI - CLASS 1, 2, & 3 VALVES
QUAD CITIES NUCLEAR POWER STATION

UNIT - 2

SYSTEM CONTAINMENT ATMOSPHERE MONITOR										P & ID M-641 Sh. 2		REVISION - DATE 2 9/17/84		PAGE 35 of 36	
VALVE NUMBER	COORDINATES	CLASS	VALVE CATEGORY	VALVE SIZE	VALVE TYPE	ACTUATOR TYPE	NORMAL POSITION	STROKE DIRECTION	TEST	TEST MODE	MAX. STROKE TIME	RELIEF REQUEST	REMARKS		
SO-2-2499-1A	B-7	NC	A	0.5	GA	SO	C	O	AT-1	RR			VR10, VR13		
SO-2-2499-1B	D-2	NC	A	0.5	GA	SO	C	O	AT-1	RR			VR10, VR13		
SO-2-2499-2A	D-6	NC	A	0.5	GA	SO	C	O	AT-1	RR			VR10, VR13		
SO-2-2499-2B	D-3	NC	A	0.5	GA	SO	C	O	AT-1	RR			VR10, VR13		
SO-2-2499-3A	B-7	NC	A	0.5	GA	SO	C	O	AT-1	RR			VR10, VR13		
SO-2-2499-3B	B-2	NC	A	0.5	GA	SO	C	O	AT-1	RR			VR10, VR13		
SO-2-2499-4A	B-6	NC	A	0.5	GA	SO	C	O	AT-1	RR			VR10, VR13		
SO-2-2499-4B	B-3	NC	A	0.5	GA	SO	C	O	AT-1	RR			VR10, VR13		



Commonwealth
Edison

INSERVICE TESTING PROGRAM

ISI-CLASS 1, 2, & 3 VALVES
QUAD CITIES NUCLEAR POWER STATION

UNIT - 2

SYSTEM ATMOSPHERIC CONTAINMENT ATMOSPHERE DILUTION										P & ID M-642 Sh. 2		REVISION - DATE 2 9/17/84		PAGE 36 of 36	
VALVE NUMBER	COORDINATES	CLASS	VALVE CATEGORY	VALVE SIZE	VALVE TYPE	ACTUATOR TYPE	NORMAL POSITION	STROKE DIRECTION	TEST	TEST MODE	MAX. STROKE TIME	RELIEF REQUEST	REMARKS		
AO-2-2599-2A	C-4	NC	A	1.0	GL	AO	C	O	AT-1	RR			VR10, VR13		
AO-2-2599-2B	C-5	NC	A	1.0	GL	AO	C	O	AT-1	RR			VR10, VR13		
AO-2-2599-3A	C-3	NC	A	1.0	GL	AO	C	O	AT-1	RR			VR10, VR13		
AO-2-2599-3B	C-6	NC	A	1.0	GL	AO	C	O	AT-1	RR			VR10, VR13		
2-2599-23A	C-3	NC	A	1.0	CK	SA	C	O	AT-1	RR			VR10, VR13		
2-2599-23B	C-6	NC	A	1.0	CK	SA	C	O	AT-1	RR			VR10, VR13		
2-2599-24A	C-3	NC	A	1.0	CK	SA	C	O	AT-1	RR			VR10, VR13		
2-2599-24B	C-6	NC	A	1.0	CK	SA	C	O	AT-1	RR			VR10, VR13		
AO-2-2599-4A	F-3	NC	A	1.0	GL	AO	C	O	AT-1	RR			VR10, VR13		
AO-2-2599-4B	E-3	NC	A	1.0	GL	AO	C	O	AT-1	RR			VR10, VR13		
PCV-2-2599-5A	F-4	NC	A	1.0	GL	AO	C	O	AT-1	RR			VR10, VR13		
PCV-2-2599-5B	E-4	NC	A	1.0	GL	AO	C	O	AT-1	RR			VR10, VR13		

SECTION 5.3

RELIEF REQUESTS FOR INSERVICE VALVE TESTING PROGRAM

RELIEF REQUEST NO. VR-1

SYSTEM: Main Steam

COMPONENT: 1(2)-203-3A,B,C,D,E
3A-Target Rock Safety Relief Valve
3B-E-Electromatic Relief Valves.

CATEGORY: B/C

FUNCTION: 1) Open upon receipt of an auto depressurization signal to blowdown reactor; 2) Act as a primary system relief valve which actuates on high system pressure.

TEST REQUIREMENT: BT - Exercise and time valves every three months.

BASIS FOR RELIEF: Relief is requested from the Section XI required testing frequency of once every three months. A failure of any relief valve to close would cause an uncontrolled, rapid depressurization of the primary system resulting in undesirable thermal gradients in the reactor vessel. Excessive testing of those valves is inadvisable because each relief valve discharge to the suppression pool detracts from the limited fatigue life of the containment.

These valves cannot be tested at cold shutdown or refueling since a system pressure of greater than 150 psig is needed to actuate the valves. Surveillance testing of these valves is, therefore, completed at very low reactor power levels. Verification of relief valve actuation is accomplished by first opening a turbine bypass valve, actuating the relief valve, and the observing a corresponding closure of the turbine bypass valve.

ALTERNATE TESTING: All relief valves will be full stroke exercised each six months during plant operation.

Additionally, stroke times for these valves will not be measured since there is no position indication circuitry to show disc movement.

RELIEF REQUEST NO. VR-2

SYSTEM: Main Steam

COMPONENT: 1(2)-203-3A (Target Rock Safety/Relief)
1(2)-203-3B,C,D,E (Electromatic Relief)

CATEGORY: BC

FUNCTION: 1) Open upon receipt of an auto depressurization signal to blow down the reactor, and 2) act as a primary system relief valve actuating on a high pressure condition. The Target Rock Safety/Relief Valve functions the same as above except, it also acts as a safety valve.

TEST REQUIREMENT: CT-2 - Verify pressure set point in accordance with IWV-3510.

BASIS FOR RELIEF: The electromatic relief valves and the relief function of the Target Rock valve are operated by actuation of a pilot solenoid valve which opens the main valve by applying a pressure differential to the main valve piston. The pilot valve is actuated from an electric signal from either the control switch, the auto-depressurization logic, or a pressure switch that senses system pressure.

RELIEF REQUEST NO. VR-2 (CONTINUED)

The requirement of IWV-3512 to check relief and safety valve set points in accordance with PTC-25.2-1976 is not applicable in this case. Therefore, relief is requested from compliance with this requirement.

The pressure set point of these valves is set by calibrating the pressure switch rather than testing the complete valve assembly. The combination of the pressure switch calibration and the exercising test for operability (BT) satisfies the intent of paragraph IWV-3510.

ALTERNATE TESTING: The pressure switch for each of these valves will be calibrated to verify the correct set point and the exercise test (BT) will verify operability of the valve.

RELIEF REQUEST NO. VR-3

SYSTEM: FEEDWATER

COMPONENT: 1(2)-220-58A, B
1(2)-220-59B
1(2)-220-62A, B

CATEGORY: C & AC

FUNCTION: The 58 and 62 valves close for containment
isolation. The 59B valve closes for HPCI injection.

TEST REQUIREMENT: CT-1 - Exercise check valve every three
months.

BASIS FOR RELIEF: These check valves cannot be tested for
operability during reactor operation because the
feedwater system is needed to maintain primary
coolant inventory. It is impractical to test these
valves during cold shutdown because the reactor
water clean-up and feedwater systems are generally
required to be operable. In addition, to verify
that these check valves stroke to the full closed
position, a leak rate test must be performed. Since
leak rate testing is performed only during refueling

RELIEF REQUEST NO. VR-3 (CONTINUED)

outages, these valves will be demonstrated to be in the full closed position at each refueling outage.

ALTERNATE TESTING: These check valves will be exercised closed during each reactor refueling outage.

RELIEF REQUEST NO. VR-4

SYSTEM: Neutron Monitoring System

COMPONENT: 1(2)-743

CATEGORY: C

FUNCTION: Primary containment isolation valve for the T.I.P.
System nitrogen purge line.

TEST REQUIREMENT: CT-1 - Exercise valve every three months.

BASIS FOR RELIEF: This check valve cannot be exercised for operability every three months because the T.I.P. system is required to be purged constantly during operation. Since there is no external means of position indication, the system must be taken out-of-service and a leak rate test performed to verify operability. Since leak rate testing is performed only during refueling outages, these valves will be demonstrated to be in the full closed position at each refueling outage.

ALTERNATE TESTING: The valves will be full stroke exercised each refueling outage.

RELIEF REQUEST NO. VR-5

SYSTEM: Standby Liquid Control

COMPONENT: 1(2)-1101-15, 16

CATEGORY: C

FUNCTION: The safety function of these check valves is to open upon a system injection.

TEST REQUIREMENT: CT-1 - Exercise valve every three months.

BASIS FOR RELIEF: Exercising these valves by system initiation is not feasible during operation due to the requirements to maintain (a) boron to reactor water separation, and (b) requirements to maintain system operability per Technical Specifications.

Since the valve operability test, in this case, must be performed with the system out of service by injecting clean demineralized water from some external source, it is more practical in terms of system availability to perform this test during cold shutdown. Currently it is not possible to achieve full flow through the valves using the method

RELIEF REQUEST NO. VR-5 (CONTINUED)

described above, only 26 gpm of the required 39 can be injected. However, the station has developed a method to achieve full flow through these valves during refueling outages using the system pumps.

ALTERNATE TESTING: These valves will be part stroke exercised during cold shutdown and full stroke exercised at each refueling outage.

RELIEF REQUEST NO. VR-6

SYSTEM: Control Rod Drive

COMPONENT: 1(2)-0305-126, 127, 114

CATEGORY: B & C

FUNCTION: These valves operate on a scram signal to drive the control rods in.

TEST REQUIREMENT: BT - Exercise and time valves every 3 months.
CT-1 - Exercise valves every three months.

BASIS FOR RELIEF: There are 177 of each of the valves listed, i.e., one for each of the 177 control rod drives. The proper operation of each of these valves is demonstrated during scram testing. During scram testing each drive's scram insertion time is measured. The Technical Specifications limit individual scram insertion times to specific values. This insures that the above mentioned valves are functioning properly.

RELIEF REQUEST NO. VR-6 (CONTINUED)

ALTERNATE TESTING: Individual scram insertion tests will be performed per the Technical Specifications frequency. The frequency is: 1) 100% of control rod drives after each refueling with reactor power equal to or less than 30%, and 2) 50% of the CRD's every 16 to 32 weeks with 100% completed every year.

RELIEF REQUEST NO. VR-7

SYSTEM: High Pressure Coolant Injection

COMPONENT: 1(2) - 2301-39

CATEGORY: C

FUNCTION: See Basis for Relief

TEST REQUIREMENT: CT-1 Exercise check valve every three months.

BASIS FOR RELIEF: This valve is designed to prevent backflow into the suppression pool in the event of a pump suction shift from the contaminated condensate storage tank (CCST) to the suppression pool. The safety related stroke direction of this valve is in the open direction to provide suction flow to the HPCI pump. There is no acceptable method for verifying this valve's ability to swing to its full open position. The system test circuit utilizes the CCST as the pump suction rather than the suppression pool. The suppression pool is not used as the pump suction for testing because of the desire to keep the system free of the dirt and contamination typically found in torus water.

RELIEF REQUEST NO. VR-7 (CONTINUED)

In lieu of the Code required full stroke test, Commonwealth Edison proposes to demonstrate valve operability by disassembling the valve and verifying that the disc swings freely to the full open position. Since this valve is not normally used, there will be no expected wear-induced degradation of the valve internals. Therefore disassembly and inspection of these valves once every third refueling outage is felt adequate to insure valve operational readiness.

ALTERNATE TESTING: Each valve will be disassembled every third refueling outage to verify that the disc swings freely to the full open position.

RELIEF REQUEST NO. VR-8

SYSTEM: High Pressure Coolant Injection, Reactor Core
Isolation Cooling

COMPONENT: 1(2)-2301-34, 45,
1(2)-1301-40, 41

CATEGORY: C

FUNCTION: Primary containment isolation.

TEST REQUIREMENT: CT-1 - Exercise valve for operability every
three months.

BASIS FOR RELIEF: It is impractical to demonstrate closure of these check valves during normal operation or cold shutdown. To verify closure upon reversal of flow a pressure test must be performed. This requires that the systems be taken out-of-service. The safety significance of these components is minimal since leakage past these valves would be contained within the HPCI and RCIC piping which returns to the containment.

RELIEF REQUEST NO. VR-8 (CONTINUED)

ALTERNATE TESTING: These valves will be demonstrated to close upon reversal of flow during each refueling outage per Appendix J test.

RELIEF REQUEST NO. VR-9

SYSTEM: Nuclear Boiler Instrumentation, Recirculation,
Reactor Core Isolation Cooling, Core Spray, High
Pressure Coolant Injection, Main Steam.

COMPONENT: Excess flow check valves as listed in program.

CATEGORY: AC

FUNCTION: Limit flow (leakage) from instrument lines
penetrating primary containment; perform containment
isolation function.

TEST REQUIREMENT: AT-2 - Seat leak rate test.

CT-1 Exercise check valves to the closed position
every three months.

BASIS FOR RELIEF: These valves are currently tested per
Technical Specification requirements which consists
of a leakage test conducted during primary system
pressure tests at the completion of each refueling
outage. The testing involves uncoupling the instru-
ment lines and verifying that each valve strokes to
the closed position. The operator also observes
that the valve limits flow to an acceptable level.

RELIEF REQUEST NO. VR-9 (CONTINUED)

This method and frequency of testing has been justified in the plant FSAR and has proven to be an adequate verification of valve performance.

ALTERNATE TESTING: These valves will be tested in the manner described above prior to start-up from each refueling outage.

RELIEF REQUEST NO. VR-10

SYSTEM: All Systems

COMPONENT: All primary containment isolation valves (listed in program as Category A).

CATEGORY: A

FUNCTION: Primary containment isolation.

TEST REQUIREMENT: AT-1 - seat leakage tests per IWV-3420.

BASIS FOR RELIEF: Primary containment isolation valves whose functional differential pressure does not exceed the primary containment accident pressure will be seat leak tested in accordance with the Appendix J requirements of 10CFR50, type C tests. At this functional differential pressure Section XI testing requirements are essentially equivalent to those of Appendix . No additional information concerning valve leakage would be gained by performing separate tests to both Section XI and Appendix J.

ALTERNATE TESTING: Valves will be seat leak tested in accordance with 10CFR50 Appendix J, type C tests.

RELIEF REQUEST NO. VR-11

Specific relief is requested from requirements of paragraphs IWV-3417(b) and IWV-3523 of Section XI of the 1980 Edition of the ASME Boiler and Pressure Vessel Code including the Addenda through Winter 1980. These paragraphs state the corrective actions to be taken when valves fail to exhibit a required change of disk position. These actions include requirements to take corrective action prior to plant startup should a failure occur during cold shutdown testing. Also stated are requirements to declare valves inoperable if corrective action is unsuccessful within a 24 hour period.

These paragraphs do not take into account the plant Technical Specification requirements for limiting conditions for operation which state the minimum conditions necessary for safe operation of the plant. The failure of a particular valve may not necessarily require a plant shutdown or prevent a startup. In addition, valves not capable of performing their safety-related function are declared inoperable as soon as that condition has been verified, not after a 24 hour period has elapsed.

For these reasons, Quad Cities Station will evaluate the condition of each valve with respect to its safety related function and take the appropriate corrective action as stated in the Technical Specification-Limiting Condition for Operation.

RELIEF REQUEST NO. VR-12

This page is intentionally left blank.

RELIEF REQUEST NO. VR-13

SYSTEM: All Systems

COMPONENTS: All power operated valves requiring full stroke testing.

CATEGORY: A and B

FUNCTION: Power operated valves

TEST REQUIREMENT: Stroke time evaluation per IWV-3417 (a).

BASIS FOR RELIEF: Paragraph IWV-3417(a) requires that valve stroke times be evaluated against the previous stroke time to determine if corrective action is required. To establish consistency in evaluating stroke times and make program implementation more practical, Quad Cities Station proposes to establish a reference stroke time for each valve which will be used for evaluating performance. This reference value will be determined by averaging stroke times. This actually results in a tighter band of acceptable stroke times, but is much easier to administer. The limiting value of full stroke time for each valve will remain as listed in the IST Program tables.

In addition, it is impractical to apply the requirements of IWV-3417(a) to valves with very short stroke times (i.e. ≤ 5 seconds) particularly solenoid valves which typically have full stroke times under one second. For these short stroke time valves, variances of 50 percent or more can occur in the measured times for reasons that are in no way related to valve performance, for example, operator reaction times. In these specific cases, verifying that the valve stroke times do not exceed 5 seconds would be sufficient to evaluate valve performance.

ALTERNATE TESTING: Based on this relief request paragraph IWV-3417(a) would, in effect, read as follows:

If, for power operated valves, an increase in stroke time of 25% or more from the established reference value for valves with full stroke times greater than ten seconds or 50% or more for valves with full stroke times between 5 and 10 seconds or 5 seconds or more for valves with full stroke times less than or equal to 5 seconds is observed, test frequency...

RELIEF REQUEST NO. VR-14

SYSTEM: Main Steam

COMPONENT: 1(2)-220-81A,B,C,D & E
1(2)-220-105A,B,C,D&E

CATEGORY: C

FUNCTION: Vacuum breakers for the main steam relief valve
discharge lines.

TEST REQUIREMENT: CT-1 Exercise check valve in the open
direction every three months.

BASIS FOR RELIEF: These check valves have no external means of
actuation for exercising. The only practical method
for exercising these valves open is by manually
pushing the disc from its seat using a small
diameter rod. Since this requires access to the
valves which are located within primary containment,
the test must be deferred to cold shutdowns when the
primary containment is de-inerted.

ALTERNATE TESTING: These check valves will be verified to freely
swing to their full open position at cold shutdowns
when the drywell is de-inerted.

RELIEF REQUEST NO. VR-15

SYSTEM: Main Steam

COMPONENT: 1(2)-203-4A through 4H

CATEGORY: C

FUNCTION: Safety relief valves for the primary coolant pressure boundary.

TEST REQUIREMENT: CT-2, Verify safety valve set point

BASIS FOR RELIEF: It is impractical for Quad Cities Station to meet the requirements of IWV-3512, in that "as-found" set points for these safety relief valves cannot be determined. The station has no on-site facility for testing safety valve set points. Currently, these valves are being removed from the system, cleaned and rebuilt, and then shipped off-site for re-verification of valve set points. Therefore, IWV-3512 cannot be applied because "as found" set points are not verified.

The frequency of removal and maintenance of these valves, however, is on a greatly accelerated basis

RELIEF REQUEST NO. VR-15 (CONTINUED)

compared to the Section XI requirements. The Technical Specification frequency for these valves has been to remove one-half (4) of the eight safety valves each refueling outage and replace them with valves that have been rebuilt and verified for proper set point.

This accelerated maintenance schedule provides adequate assurance that these valves will perform reliably.

ALTERNATE TESTING: One-half (4) of the total number of safety valves will be removed and replaced with valves that have been rebuilt and had their set points verified each refueling outage.

RELIEF REQUEST NO VR-16

SYSTEM: Diesel Generator Starting Air Valve

COMPONENT: 1,2 & 1/2-4699-226

CATEGORY: B

FUNCTION: This valve operates on a signal to start the diesel generator.

TEST REQUIREMENT: BT - Exercise and time valves every three months.

BASIS FOR RELIEF: This Air-Operated valve cannot be verified to open in \leq 5 seconds because it has no remote position indicator. Timing these valves during testing, therefore, has no relevance, and a successful \leq 5 seconds diesel generator starting would indicate a sufficient demonstration of the operability of the valve.

ALTERNATE TESTING: This valve will be exercised and fail-safe operability will be observed without timing at least every 3 months.

SECTION 5.4

COLD SHUTDOWN JUSTIFICATIONS
FOR INSERVICE VALVE TESTING PROGRAM

COLD SHUTDOWN JUSTIFICATIONS

Justifications 1 through 9 inclusive are applicable when plant operating conditions are such that specific valves cannot be full-stroke tested. Those valves which have part-stroke capabilities will be tested in that manner every three months and full-stroke tested during cold shut-downs. Those valves which cannot be full-stroke or part-stroke tested during plant operation will be full-stroke tested during cold shut-downs. The aforementioned testing meets the requirements of IWV 3412(a).

Justification 9 is applicable when fail-safe valves cannot be tested during plant operation by observing their operation upon a loss of actuator power. These valves will be tested during cold shutdowns. This testing meets the requirements of IWV-3415.

JUSTIFICATION NO. J-1

SYSTEM: Main Steam

FUNCTION: Primary containment isolation valves for the main steam lines.

COMPONENT: 1(2)-203-1A, B, C, D
1(2)-203-2A, B, C, D

REASONS: Full stroke testing these valves during normal reactor operation requires isolating one of the four main steam lines. Isolation of these lines results in primary system pressure spikes, reactor power fluctuations, and increased flow in the unisolated steam lines. This unstable operation can lead to a reactor scram, and as discussed in NUREG-0626 pressure transients resulting from full stroke testing MSIVs increase the chances of actuating primary system relief valves.

JUSTIFICATION NO. J-2

SYSTEM: Residual Heat Removal, Core Spray, High Pressure Coolant Injection.

COMPONENT: 1(2)-1001-68A & B
1(2)-1402-9A & B
1(2)-2301-7

FUNCTION: Open upon System Injection

REASONS: These valves have remote position indicators. However, during normal operation the high differential pressure across the valve seats prohibits exercising. Additionally, the residual heat removal and core spray system valves (i.e., 1(2)-1001-68A, 68B & 1(2)-1402-9A,9B) are located inside the primary containment which is inerted with nitrogen during normal operation. The high pressure coolant injection valve (1(2)-2301-7) is located inside the main steam isolation valve room which is a designated high radiation area where normal power operation radiation dose rates are one to two rem/hour. Also high temperatures exist in this area (120° to 140°F) which further increases the hazards involved in entering the area for this testing. The accumulated dose to conduct this test would be approximately 1.5 man-rem.

JUSTIFICATION NO. J-3

SYSTEM: Recirculation

COMPONENT: 1(2)-202-5A, B

FUNCTION: In a design basis loss of coolant accident, one of these valves will close depending on the location of the line break.

REASONS: These valves cannot be fully stroke tested or partial stroke tested during normal operation since isolation of a recirculation loop would cause a recirculation pump trip. One loop operation is restricted by the Technical Specifications.

JUSTIFICATION NO. J-4

SYSTEM: RHR-Head Spray/Shutdown Cooling Subsystems

COMPONENT: 1(?) - 1001-60, 63, 47, 50

FUNCTION: Primary containment isolation valves for RHR Head Spray and Shutdown Cooling Subsystems.

REASONS: Relief is requested from partial or full stroke testing these valves during operation. These valves, which are normally closed during plant operation, serve as isolation between the high and low pressure piping. Protective interlocks prevent opening these valves while the reactor is at operating pressure.

JUSTIFICATION NO. J-5

SYSTEM: High Pressure Coolant Injection.

COMPONENT: 1(2)-2301-4&5.

FUNCTION: Primary containment isolation.

REASONS: The above valves are normally open to supply steam to the turbine driven HPCI injection pumps. Conservatively these valves are left in the open position to insure that driving steam can be supplied to these turbines at all times during operation. Also, these valves serve a primary containment isolation function (Group 4).

Quad Cities Station feels that to close these valves during operation would place the operation of the system in an untenable condition. Further, if either were to fail closed it would render the HPCI system inoperable.

JUSTIFICATION NO. J-6

SYSTEM: Residual Heat Removal

COMPONENT: 1(2)-1001-19A & B

FUNCTION: RHR System cross-tie line isolation valves.

REASONS: These valves are normally in their safety position (open) and are only closed a very small percentage of plant operating time when the system is in the residual heat removal mode. Testing these valves during normal operation places the plant in an unsafe mode because a failure of either valve in the closed position renders the low pressure coolant injection (LPCI) function inoperable. The LPCI function of RHR is designed such that three of the four pumps are required to provide makeup flow to either recirculation loop in the event of a design basis loss of coolant accident. This requires the crosstie line to be open and, hence, both the 1001-19A and B valves. In accordance with NRC Staff guidelines on excluding the cycling of valves whose failure in a non-conservative position would cause a loss of system function.

JUSTIFICATION NO. J-7

SYSTEM: Residual Heat Removal

COMPONENT: 1(2)-1001-28 A&B
1(2)-1001-29 A&B

FUNCTION: LPCI injection valves; primary containment isolation (29A&B); pressure isolation.

REASONS: Relief is requested from exercising these valves during normal reactor operation. Both sets of valves are included because they are interlocked such that one of the two valves must be closed at all times to provide the pressure isolation function. A failure of any one of these valves in the closed position would render the entire LPCI function technically inoperable since both injection loops must be available in the design basis accident to provide coolant to the unbroken recirculation loop and this loop could be either one of the two.

JUSTIFICATION NO. J-8

SYSTEM: Pressure Suppression

COMPONENT: 1(2)-1601-20 A&B

FUNCTION: Reactor building to torus vacuum breaker isolation valves and primary containment isolation.

REASONS: Exercising these valves open during normal plant operation compromises primary containment integrity and reduces safety margins by leaving only a single check valve (1601 - 31 A or B) to maintain the primary containment boundary.

JUSTIFICATION NO. J-9

SYSTEM: Control Rod Drive

COMPONENT: 1(2)-302-21 A&B & C&D
1(2)-302-22 A&B & C&D

FUNCTION: Scram discharge volume vent and drain valves.

REASONS: These valves are normally in the open position to allow water which enters the scram discharge volume from normal CRD leakage to drain into the reactor building equipment drain tank. This assures that a sufficient volume is always available to accept scram discharge water following a scram.

The testing of these valves during plant operation has the potential of isolating the scram discharge volume and the increasing water level in the volume would then cause a reactor scram. Consistent with NRC Staff guidelines concerning the cycling of valves that could potentially place the plant in an unsafe mode of operation, it is felt that these valves should be tested at cold shutdown. This applies to the vent and drain valves since the air supply to the valves and the test circuit is common for all eight valves.