

Florida Power

CORPORATION

Crystal River Unit 3

Docket No. 50-302

May 1, 1996
3F0596-03

U. S. Nuclear Regulatory Commission
Attention: Document Control Desk
Washington, D. C. 20555

Subject: Licensee Event Report (LER) 96-005-01

Dear Sir:

Please find the enclosed Licensee Event Report (LER) 96-005-01. Its supplemental report is submitted by Florida Power Corporation in accordance with 10 CFR 50.73.

This supplement includes reference to procedure changes to incorporate guidance to be followed by operators regarding isolation of the non-Engineered Safeguards selected Reactor Building Cooling Unit (RBCU) supplied by Nuclear Services Closed Cycle Cooling Water (SW). These changes are sufficient to resolve the safety concerns associated with excessive SW flow to the RBCU's. Therefore, compliance with Crystal River Unit 3's design basis has been achieved. Engineering personnel will continue to evaluate similar scenarios for single failures to ensure there are no other examples of this condition. This action has been reassigned within FPC engineering to the I&C discipline and requires an extension to August 30, 1996. This date is necessary due to the limited available resources in the I&C section with respect to their support of the Refuel 10 outage and other emergent issues.

Sincerely,

B. J. Hickle, Director
Nuclear Plant Operations

TWC:ff

070048

Attachment

xc: Regional Administrator, Region II
Project Manager, NRR

Senior Resident Inspector

IE22
11

LICENSEE EVENT REPORT (LER)

ESTIMATED BURDEN PER RESPONSE TO COMPLY WITH THIS INFORMATION COLLECTION REQUEST: 50.0 HOURS. FORWARD COMMENTS REGARDING BURDEN ESTIMATE TO THE RECORDS AND REPORTS MANAGEMENT BRANCH (MNBB 7714), U.S. NUCLEAR REGULATORY COMMISSION, WASHINGTON, DC 20555-0001, AND TO THE PAPERWORK REDUCTION PROJECT (3150-0104), OFFICE OF MANAGEMENT AND BUDGET, WASHINGTON DC 20503.

FACILITY NAME (1) CRYSTAL RIVER UNIT 3 (CR-3)						DOCKET NUMBER (2) 0 5 0 0 0 3 0 2			PAGE (3) 1 OF 0 9		
--	--	--	--	--	--	--------------------------------------	--	--	----------------------	--	--

TITLE (4)
Inadequate Failure Modes Review Creates Possibility of Cooling Water Flow Outside Design Limits

EVENT DATE (5)			LER NUMBER (6)			REPORT DATE (7)			OTHER FACILITIES INVOLVED (8)					
MONTH	DAY	YEAR	YEAR	SEQUENTIAL NUMBER	REVISION NUMBER	MONTH	DAY	YEAR	FACILITY NAMES N/A			DOCKET NUMBER(S) 0 5 0 0 0		
0 1 3	0 9	6 9 6	6 9 6	0 0 5	0 1	0 5	0 1	9 6	N/A			0 5 0 0 0		

OPERATING MODE (9) 1	THIS REPORT IS SUBMITTED PURSUANT TO THE REQUIREMENTS OF 10 CFR §: (CHECK ONE OR MORE OF THE FOLLOWING) (11)										
	20.402(b)	20.405(c)	50.73(a)(2)(iv)	73.71(b)							
	20.405(a)(1)(i)	50.36(c)(1)	50.73(a)(2)(v)	73.71(c)							
	20.405(a)(1)(ii)	50.36(c)(2)	50.73(a)(2)(vii)	OTHER (Specify in Abstract below and in Text, NRC Form 366A)							
	20.405(a)(1)(iii)	50.73(a)(2)(i)	50.73(a)(2)(viii)(A)								
	20.405(a)(1)(iv)	X 50.73(a)(2)(ii)	50.73(a)(2)(viii)(B)								
POWER LEVEL (10) 1 0 0	20.405(a)(1)(v)	50.73(a)(2)(iii)	50.73(a)(2)(x)								

LICENSEE CONTACT FOR THIS LER (12)										
NAME T.W. Catchpole, Sr. Nuclear Licensing Engineer							TELEPHONE NUMBER AREA CODE 3 5 2 5 6 3 - 4 6 0 1			

COMPLETE ONE LINE FOR EACH COMPONENT FAILURE IN THIS REPORT (13)									
CAUSE	SYSTEM	COMPONENT	MANUFACTURER	REPORTABLE TO NPRDS	CAUSE	SYSTEM	COMPONENT	MANUFACTURER	REPORTABLE TO NPRDS

SUPPLEMENTAL REPORT EXPECTED (14)				EXPECTED SUBMISSION DATE (15)	MONTH	DAY	YEAR
YES (If yes, complete EXPECTED SUBMISSION DATE)				X NO			

ABSTRACT (Limit to 1400 spaces, i.e., approximately fifteen single-space typewritten lines) (16)

On January 30, 1996, Florida Power Corporation's Crystal River Unit 3 (CR-3) was in MODE ONE (POWER OPERATION), operating at 100% reactor power and generating 871 megawatts. While performing a review for unanalyzed component failures in the Nuclear Services Closed Cycle Cooling Water (SW) system, it was discovered that, in certain accident conditions, SW inlet and outlet valves for all three Reactor Building Cooling Units (RBCU) would open with only one SW pump in operation. Two RBCU's are in operation during post-accident conditions. Adding the third RBCU would result in increased total SW flow and decreased flow to individual components. Increased SW flow may also result in a diesel generator loading for a few seconds above the approved kilowatt load limits. A one-hour report was made to identify a condition outside CR-3's design basis. The cause was an error by Architect-Engineer personnel who prepared a design change which allowed SW flow to all three RBCU's without proper consideration of all failure modes. SW flow to one of three RBCU's will be isolated for specific conditions, allowing SW to be considered operable. A summary of the event has been distributed to design personnel as a "lessons learned" regarding failure modes analyses. In addition, a review of other similar scenarios will be performed to ensure there are no additional examples of this condition.

LICENSEE EVENT REPORT (LER)
TEXT CONTINUATION

ESTIMATED BURDEN PER RESPONSE TO COMPLY WITH THIS INFORMATION COLLECTION REQUEST: 50.0 HOURS. FORWARD COMMENTS REGARDING BURDEN ESTIMATE TO THE RECORDS AND REPORTS MANAGEMENT BRANCH (MNBB 7714), U.S. NUCLEAR REGULATORY COMMISSION, WASHINGTON, DC 20555-0001, AND TO THE PAPERWORK REDUCTION PROJECT (3150-0104), OFFICE OF MANAGEMENT AND BUDGET, WASHINGTON DC 20503.

FACILITY NAME (1) CRYSTAL RIVER UNIT 3 (CR-3)	DOCKET NUMBER (2) 0 5 0 0 0 3 0 2	LER NUMBER (6)			PAGE (3) 9 6 — 0 0 5 — 0 1 0 2 OF 0 9
		YEAR	SEQUENTIAL NUMBER	REVISION NUMBER	

TEXT (If more space is required, Use additional NRC Form 366A's (17))

EVENT DESCRIPTION

On January 30, 1996, Florida Power Corporation's (FPC) Crystal River Unit 3 (CR-3) was in MODE ONE (POWER OPERATION), operating at 100% reactor power and generating 871 megawatts. While performing corrective actions associated with a previous event which required a search for unanalyzed component failures in the Nuclear Services Closed Cycle Cooling Water [CC](SW) system, engineering personnel discovered an accident scenario which could cause significant SW system and component flow concerns. The accident scenario involves a Loss of Coolant Accident (LOCA) concurrent with a Loss of Offsite Power (LOOP) and a single failure of either the "A" or "B" Train Direct Current (DC) Power. SWV-35, 37, 39, 41, 43, and 45 are SW inlet and outlet valves [CC,V] to the three Reactor Building Cooler Units (RCBU) [BK,AHU]. The power supplies for the valves are 250/125 Volt DC (VDC) Distribution Panel [EJ,PL] DPDP-5A (SWV-35 and 41), DPDP-1B (SWV-37 and 43), and DPDP-5B (SWV-39 and 45). These loads are essential for post-accident cooling of the containment atmosphere and remain open on ES actuation for the operating fans. The control power for SW Pump [CC,P] SWP-1A is from DPDP-5A, and control power for SWP-1B is from DPDP-5B. See Figure 2.

In the accident scenario, if AHF-1A and AHF-1C are selected for Engineered Safeguards (ES) System [JE] actuation, loss of "B" Train DC power will cause SWV-37 and 43 to fail open. SWV-35 and 41, and SWV-39 and 45 were already open. It will also result in loss of SWP-1B. In addition, loss of "B" train DC will result in loss of start-up field current (field flash) which is needed by the "B" Emergency Diesel Generator [EK,DG] (EDG) to initiate generator output. Therefore, the "B" EDG will be lost. With SWP-1A the only SW pump running and all six SW inlet and outlet valves open, total SW system flow will increase above currently approved limits, and individual component flows may decrease below their design basis. This scenario applies equally to the situation where AHF-1A and AHF-1B are ES selected.

Since the SW system is designed (flow balanced) for only 2 RBCU's during ES operations, the Shift Supervisor on Duty (SSOD) declared the SW system inoperable. At 1800 hours, the SSOD entered Improved Technical Specifications (ITS) Limiting Condition for Operation (LCO) 3.0.3, which requires action to be initiated within 1 hour to place the unit in MODE 3 (HOT STANDBY) within 7 hours. At 1830 hours, the Nuclear Regulatory Commission (NRC) was notified of the event via the Emergency Notification System per the requirements of 10CFR50.72(b)(1)(ii)(B). The event was assigned Event Number 29909. ITS 3.0.3 was exited at 1845 hours after SW to one of the RBCU's (AHF-1B) was isolated with manual valves not susceptible to the above failure mode, thereby restoring SW to OPERABLE status.

This report is being submitted in accordance with 10CFR50.73(a)(2)(ii)(B) to describe a condition of operation outside CR-3's design basis.

LICENSEE EVENT REPORT (LER)
TEXT CONTINUATION

ESTIMATED BURDEN PER RESPONSE TO COMPLY WITH THIS INFORMATION COLLECTION REQUEST: 50.0 HOURS. FORWARD COMMENTS REGARDING BURDEN ESTIMATE TO THE RECORDS AND REPORTS MANAGEMENT BRANCH (MNB 7714), U.S. NUCLEAR REGULATORY COMMISSION, WASHINGTON, DC 20555-0001, AND TO THE PAPERWORK REDUCTION PROJECT (3150-0104), OFFICE OF MANAGEMENT AND BUDGET, WASHINGTON DC 20503.

FACILITY NAME (1) CRYSTAL RIVER UNIT 3 (CR-3)	DOCKET NUMBER (2)		LER NUMBER (6)			PAGE (3) 0 3 OF 0 9
			YEAR	SEQUENTIAL NUMBER	REVISION NUMBER	
	0 5 0 0 0 3 0 2	9 6	0 0 5	0 1		

TEXT (If more space is required, Use additional NRC Form 386A's (17))

EVENT EVALUATION

The SW System removes heat from various components and transfers this heat to the Nuclear Services and Decay Heat Seawater [KE](RW) System. SW provides a redundant function to the Reactor Building Spray [BE] System (BS), through the reactor building cooling units, for the purpose of removing the heat released inside the containment following a gross leakage of primary coolant [AB] or main steam [SB]. The Design Basis LOCA evaluation described in FSAR Chapter 14 assumes the worst case single failure is a loss of one train of emergency power due to failure of an Emergency Diesel Generator to start. Consequently, only one RB spray train and one RB cooling unit are assumed to be available for post-accident reduction of containment pressure.

There are three RBCU's labeled AHF-1A, AHF-1B, and AHF-1C. Each unit consists of a fan assembly and ventilation fan motor. All loads shown on Figure 1 are cooled during normal operation by the SW System, with the exception of the RB Ventilation Fan Motor Coolers and the RB Fan Assembly Cooling Coils. These two loads are normally supplied with cooling water from the nonsafety related Industrial Cooler (CI) System. However, following ES actuation, the RB Ventilation Fan Motor Coolers and the RB Fan Assembly Cooling Coils receive their cooling water from the SW System.

For single failure considerations, both 100% capacity emergency pumps SWP-1A and SWP-1B, are designed to start on an ES Actuation to ensure sufficient flow to all safety related components. SWP-1C, the normal duty pump, is powered from the 4160V unit Bus 3B, and SWP-1A and 1B are powered from the 4160V ES Buses 3A and 3B respectively. SWP-1C automatically shuts down when either emergency pump is running.

The SW system is designed to be hydraulically balanced to provide the design cooling water flows to designated safety related components. As a result of Licensee Event Report (LER) 95-010-00, which addressed inadequate flow balancing of an alternate system, FPC committed to re-balance the SW system during Refuel 10. FPC began Refuel 10 on February 16, 1996. In preparing for the balance, the required lower and upper flow to each component supplied by SW were determined. The lower limit is based on minimum equipment design basis requirements and the upper limit is based on EDG loading requirements.

Subsequent to identification of this deficiency, engineering evaluated its effect on reduction in flow to other components supplied by SW and the impact of the increased flow on EDG loading. The evaluation indicated that, with SW Flow hydraulically balanced to the upper limits established by engineering guidance, by valving-in the third RB Fan, the total SW system flow will reach approximately 11,000 gallons per minute (gpm). The engineering evaluation noted that increasing SWP-1A flow to 11,000 gpm results in exceeding the analyzed upper loading limit of EDG "A" by 7.6 KW above the loading limit of 3500 KW for a

LICENSEE EVENT REPORT (LER)
TEXT CONTINUATION

ESTIMATED BURDEN PER RESPONSE TO COMPLY WITH THIS INFORMATION COLLECTION REQUEST: 50.0 HOURS. FORWARD COMMENTS REGARDING BURDEN ESTIMATE TO THE RECORDS AND REPORTS MANAGEMENT BRANCH (MNBB 7714), U.S. NUCLEAR REGULATORY COMMISSION, WASHINGTON, DC 20555-C 301, AND TO THE PAPERWORK REDUCTION PROJECT (3150-0104), OFFICE OF MANAGEMENT AND BUDGET, WASHINGTON DC 20503.

FACILITY NAME (1) CRYSTAL RIVER UNIT 3 (CR-3)	DOCKET NUMBER (2)		LER NUMBER (6)			PAGE (3)
	YEAR	SEQUENTIAL NUMBER	REVISION NUMBER			
	0 5 0 0 0 3 0 2	8 6	--- 0 0 5	--- 0 1	0 4	OF 0 9

TEXT (If more space is required, Use additional NRC Form 366A's (17))

period of a few seconds during starting of Load Block 6. The automatic sequential loading of CR-3' EDG's is accomplished in six blocks to limit the maximum system voltage dip. The EDG will return to within its rating limits as soon as the starting current inrush of the sixth block is over. The starting current inrush lasts approximately 2 to 3 seconds. Exceeding the EDG rating limit of 3500 KW for a brief period of time (2 to 3 seconds) is not expected to have a detrimental effect on the EDG, nor will exceeding 3500 KW cause the EDG to trip. Increasing SW flow to 11,000 gpm resulted in an increased EDG "B" load, however the increase was within the analyzed load limit. Preliminary computer hydraulic analyses indicated based on increased flow to the third RB fan, that a reduction of up to 8% could be expected in SW flow to other components.

It should be noted this event concerns degraded SW flow, not loss of flow. Nevertheless, in a hypothetical worst case scenario, wherein a substantial number of SW cooled components would be damaged by reduced cooling water flow, safe shutdown of the reactor would still be accomplished. Decay heat removal could be accomplished by placing the Reactor Coolant System (RCS) in natural circulation and steaming the Once Through Steam Generators [AB,SG](OTSG) to the atmosphere. Emergency feedwater to the OTSG's would be provided by the turbine driven emergency feedwater pump [BA,P]. RCS pressure control would be maintained by EDG powered pressurizer heaters [AB,EHTR] and reactivity control would be achieved through boration using an EDG powered Boric Acid Pump [BQ,P]. RCS inventory would be controlled using a Makeup Pump [CB,P](MUP) powered by the available EDG. Since MUP-1A is normally cooled by SW, operator alignment of the Decay Heat Closed Cycle Cooling [CC](DC) system to MUP-1A would be necessary if the "B" EDG failed. The DC system provides cooling water flow to MUP-1C, Building Spray pumps [BE,P](BSP), Decay Heat Removal pumps [BP,P](DHP), and Decay Heat Seawater pumps [BI,P](RWP), thereby providing cooling to plant components Post-LOCA to achieve safe shutdown.

Based on the procedures (for example, Abnormal Procedure AP-330 titled "Loss of Nuclear Service Cooling"), training, and simulator experiences of the CR-3 operating personnel, control of the postulated deficiency would be maintained and safe shutdown of the reactor would be achieved. The integrity of the principal safety barriers would be maintained; therefore, the safety of the general public would be assured.

CAUSE

The cause of this event is an error by Architect Engineer personnel. An inadequate failure modes and effects analysis was applied to a modification installed in 1994 to change SWV-42, 43, and 45 circuitry to provide cooling water flow to 2 out of the 3 RB Fans. Prior to installation of this modification, all 3 fans received cooling flow during ES conditions. The design engineers for the modification concentrated on the control circuitry for eliminating cooling flow

LICENSEE EVENT REPORT (LER)
TEXT CONTINUATION

ESTIMATED BURDEN PER RESPONSE TO COMPLY WITH THIS INFORMATION COLLECTION REQUEST: 50.0 HOURS. FORWARD COMMENTS REGARDING BURDEN ESTIMATE TO THE RECORDS AND REPORTS MANAGEMENT BRANCH (MNBB 7714), U.S. NUCLEAR REGULATORY COMMISSION, WASHINGTON, DC 20555-0001, AND TO THE PAPERWORK REDUCTION PROJECT (3150-0104), OFFICE OF MANAGEMENT AND BUDGET, WASHINGTON DC 20503.

FACILITY NAME (1) CRYSTAL RIVER UNIT 3 (CR-3)	DOCKET NUMBER (2)		LER NUMBER (6)			PAGE (3)											
			YEAR	SEQUENTIAL NUMBER	REVISION NUMBER												
	0	5	0	0	0		3	0	2	9	6	0	0	1	0	5	OF

TEXT (If more space is required, Use additional NRC Form 366A's (17))

to the non-operating fan and also ensured the fail-safe position for the valves would be "open" for loss of DC power, thereby ensuring cooling water would be available to an operating fan if the valves were to lose DC power. The design engineers did not consider the consequences of additional SW flow resulting from loss of DC and also, additional EDG loading resulting from this additional flow.

IMMEDIATE CORRECTIVE ACTION

The actions taken by the SSOD to select AHF-1C as the "B" ES fan while isolating AHF-1B with manual valves, restored the SW system and EDG "A" loading to within their respective design limits and to fully OPERABLE status.

ADDITIONAL CORRECTIVE ACTION

The following options have been provided by design engineering to limit AHF-1A, 1B, and/or 1C operation by use of manual isolation of SW supply or return valves outside containment. These options were incorporated into Operating Procedure OP-417 "Containment Operating Procedure" effective March 27, 1996 to ensure the SW flow assumptions are maintained by closing the SW valves on the idle non-ES selected RBCU. DC power failures have been reviewed for each of the following options with no SW flow or EDG overloading concerns identified.

- a) ES-select AHF-1A and 1B with manual isolation of SW flow to AHF-1C.
- b) ES-select AHF-1A and 1C with manual isolation of SW flow to AHF-1B.
- c) ES-select AHF-1B and 1C with no manual isolation of SW flow to AHF-1A required.

ACTION TO PREVENT RECURRENCE

1. FPC is bringing more of the overall design work back within the CR-3 design organization. This has already begun and will continue over the next few years.
2. CR-3's licensing basis for single failure design applicable to the SW system states that a single active failure within an Engineered Safety Feature (ESF) support system must not disable the ESF system from accomplishing its design basis safety function. To ensure there are no additional examples of this condition, other similar scenarios for systems that provide cooling flow to safety related equipment will be reviewed. The focus of this review will be loss of power to a given safety related valve wherein the loss of power can cause system flow and EDG loading to increase beyond analyzed limits. The criteria, schedule and resources required to perform this review will be established by August 30, 1996.

LICENSEE EVENT REPORT (LER)
TEXT CONTINUATION

ESTIMATED BURDEN PER RESPONSE TO COMPLY WITH THIS INFORMATION COLLECTION REQUEST: 50.0 HOURS. FORWARD COMMENTS REGARDING BURDEN ESTIMATE TO THE RECORDS AND REPORTS MANAGEMENT BRANCH (MNBB 7714), U.S. NUCLEAR REGULATORY COMMISSION, WASHINGTON, DC 20555-0001, AND TO THE PAPERWORK REDUCTION PROJECT (3150-0104), OFFICE OF MANAGEMENT AND BUDGET, WASHINGTON DC 20503.

FACILITY NAME (1) CRYSTAL RIVER UNIT 3 (CR-3)	DOCKET NUMBER (2)		LER NUMBER (6)			PAGE (3)
	YEAR	SEQUENTIAL NUMBER	REVISION NUMBER			
	0 5 0 0 0 3 0 2	9 6	0 0 5	0 1	0 6	OF 0 9

TEXT (If more space is required, Use additional NRC Form 366A's (17))

- This design/personnel error was the subject of discussion between the Manager, Nuclear Engineering Design (NED) and the Design Engineering Review Board (DERB) to heighten awareness of the members for future design reviews. A summary of this discussion was distributed to all design personnel within NED as a "lessons learned" with special emphasis on conducting a thorough failure modes and effects analysis. In addition, this information has been discussed in detail with Architect Engineer management.

PREVIOUS SIMILAR EVENTS

There have been five previous reportable events involving reduced cooling water flow. LER 89-030 reported an incorrect RWP impeller; LER 94-013 addressed heat exchanger fouling; LER 94-014 was a voluntary LER which reported discrepancies between design basis documents and technical specifications regarding operation with 3 Reactor Building Fan/Coolers in service - initiating conditions did not involve loss of DC power; LER 95-10 addressed low flow to Makeup Pumps when cooling is aligned to the DC system; and LER 95-17 addressed reduced SW flow to the Control Complex Chillers. Two previous reportable events described in LER 87-019 and LER 92-005 describe EDG design rating and loading concerns.

ATTACHMENT

- Attachment 1 - Abbreviations, Definitions and Acronyms
- Figure 1 - Nuclear Services Closed Cycle Cooling System (simplified)
- Figure 2 - DC Distribution System (simplified)

LICENSEE EVENT REPORT (LER)
TEXT CONTINUATION

ESTIMATED BURDEN PER RESPONSE TO COMPLY WITH THIS INFORMATION COLLECTION REQUEST: 50.0 HOURS. FORWARD COMMENTS REGARDING BURDEN ESTIMATE TO THE RECORDS AND REPORTS MANAGEMENT BRANCH (MNBB 7714), U.S. NUCLEAR REGULATORY COMMISSION, WASHINGTON, DC 20555-0001, AND TO THE PAPERWORK REDUCTION PROJECT (3150-0104), OFFICE OF MANAGEMENT AND BUDGET, WASHINGTON DC 20503.

FACILITY NAME (1) CRYSTAL RIVER UNIT 3 (CR-3)	DOCKET NUMBER (2)		LER NUMBER (8)			PAGE (3)															
			YEAR	SEQUENTIAL NUMBER	REVISION NUMBER																
	0	5	0	0	0	3	0	2	9	6	---	0	0	5	---	0	1	0	7	OF	0

TEXT (If more space is required, Use additional NRC Form 306A's (17))

ATTACHMENT 1 - ABBREVIATIONS, DEFINITIONS AND ACRONYMS

- CR-3 Crystal River Unit 3
- DERB The Design Engineering Review Board consists of a Chairman and engineers with demonstrated technical knowledge/experience in their specific discipline. DERB reviews specific modifications, calculations and other design work for technical accuracy and adherence to requirements.
- ES Engineered Safeguards
- LOCA Loss of Coolant Accident
- LOOP Loss of Offsite Power
- MODE ONE POWER OPERATION (Greater than 5 percent Rated Thermal Power)
- MODE THREE HOT STANDBY
- RBCU Reactor Building Cooling Unit
- SW Nuclear Services Closed Cycle Cooling Water

NOTES: ITS defined terms appear capitalized in LER text (e.g. MODE ONE)

 Defined terms/acronyms/abbreviations appear in parentheses when first used (e.g. Reactor Building (RB)).

 EIS codes appear in square brackets (e.g. Makeup Tank [CB,TK])

LICENSEE EVENT REPORT (LER) TEXT CONTINUATION

ESTIMATED BURDEN PER RESPONSE TO COMPLY WITH THIS INFORMATION COLLECTION REQUEST: 50.0 HOURS. FORWARD COMMENTS REGARDING BURDEN ESTIMATE TO THE RECORDS AND REPORTS MANAGEMENT BRANCH (MNB 7714), U.S. NUCLEAR REGULATORY COMMISSION, WASHINGTON, DC 20555-0001, AND TO THE PAPERWORK REDUCTION PROJECT (3150-0104), OFFICE OF MANAGEMENT AND BUDGET, WASHINGTON DC 20503.

FACILITY NAME (1) CRYSTAL RIVER UNIT 3 (CR-3)	DOCKET NUMBER (2) 0500030296	LER NUMBER (6)		PAGE (3) 08 OF 09
		YEAR 96	SEQUENTIAL NUMBER 005	

TEXT (If more space is required, Use additional NRC Form 396A's (17))

NUCLEAR SERVICES CLOSED CYCLE COOLING

(AMPLIFIER) Rev. 1

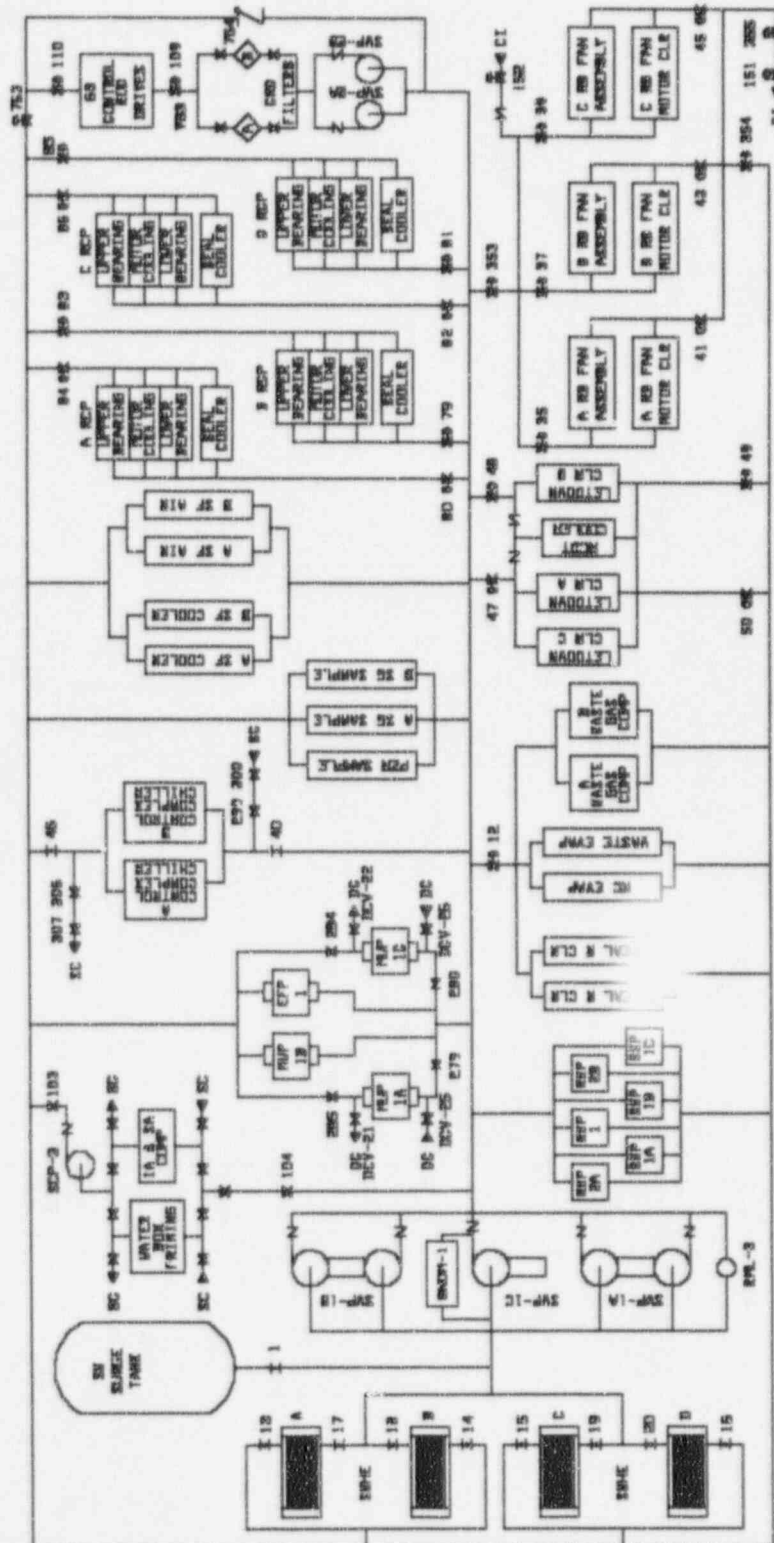

Figure 1: Nuclear Services Closed Cycle Cooling System

LICENSEE EVENT REPORT (LER)
TEXT CONTINUATION

ESTIMATED BURDEN PER RESPONSE TO COMPLY WITH THIS INFORMATION COLLECTION REQUEST: 30.0 HOURS. FORWARD COMMENTS REGARDING BURDEN ESTIMATE TO THE RECORDS AND REPORTS MANAGEMENT BRANCH (NRCB 7714), U.S. NUCLEAR REGULATORY COMMISSION, WASHINGTON, DC 20545-0001, AND TO THE PAPERWORK REDUCTION PROJECT (3150-0104), OFFICE OF MANAGEMENT AND BUDGET, WASHINGTON DC 20503.

FACILITY NAME (1)

CRYSTAL RIVER UNIT 3 (CR-3)

DOCKET NUMBER (2)

0 5 0 0 0 3 0 2 9 8 0 0 5 0 1 0 9 OF 0 9

LER NUMBER (6)

PAGE (3)

TEXT (If more space is required, Use additional NRC Form 366A * (17))

CR#3 D. C. DISTRIBUTION SYSTEM

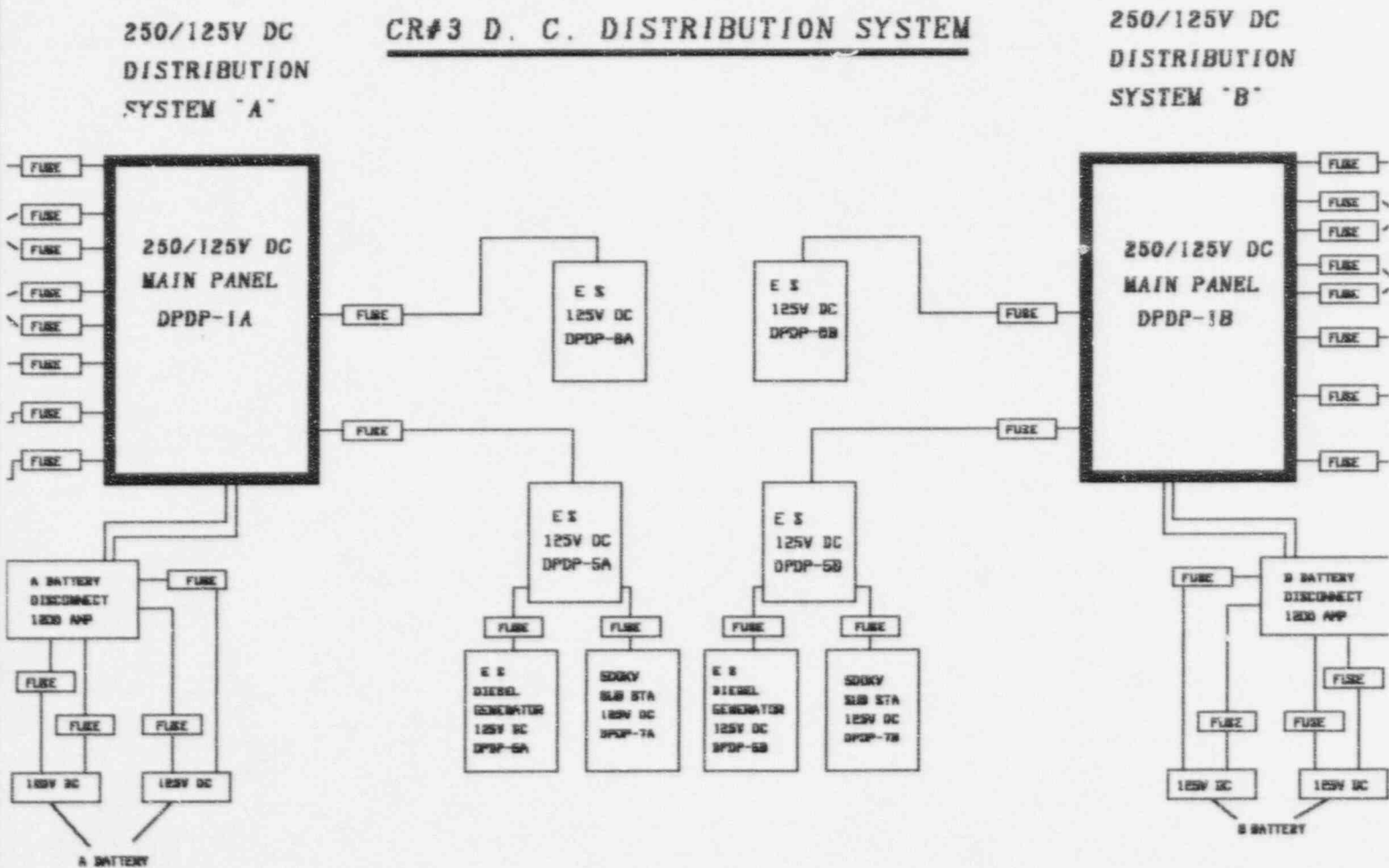

Figure 2: DC Distribution System

LICENSEE EVENT REPORT (LER)
TEXT CONTINUATION

ESTIMATED BURDEN PER RESPONSE TO COMPLY WITH THIS INFORMATION COLLECTION REQUEST: 50.0 HOURS. FORWARD COMMENT'S REGARDING BURDEN ESTIMATE TO THE RECORDS AND REPORTS MANAGEMENT BRANCH (NMB 7714, U.S. NUCLEAR REGULATORY COMMISSION, WASHINGTON, DC 20555-0001) AND TO THE PAPERWORK REDUCTION PROJECT (3156-0104), OFFICE OF MANAGEMENT AND BUDGET, WASHINGTON, DC 20503.

FACILITY NAME (1)

CRYSTAL RIVER UNIT 3 (CR-3)

DOCKET NUMBER (2)

0 5 0 0 0 3 0 2 9 8 0 0 5 0 1 0 9 OF 0 9

LER NUMBER (6)

YEAR SEQUENTIAL NUMBER REVISION NUMBER

PAGE (3)

TEXT (If more space is required, Use additional NRC Form 990A's (17))

CR#3 D. C. DISTRIBUTION SYSTEM

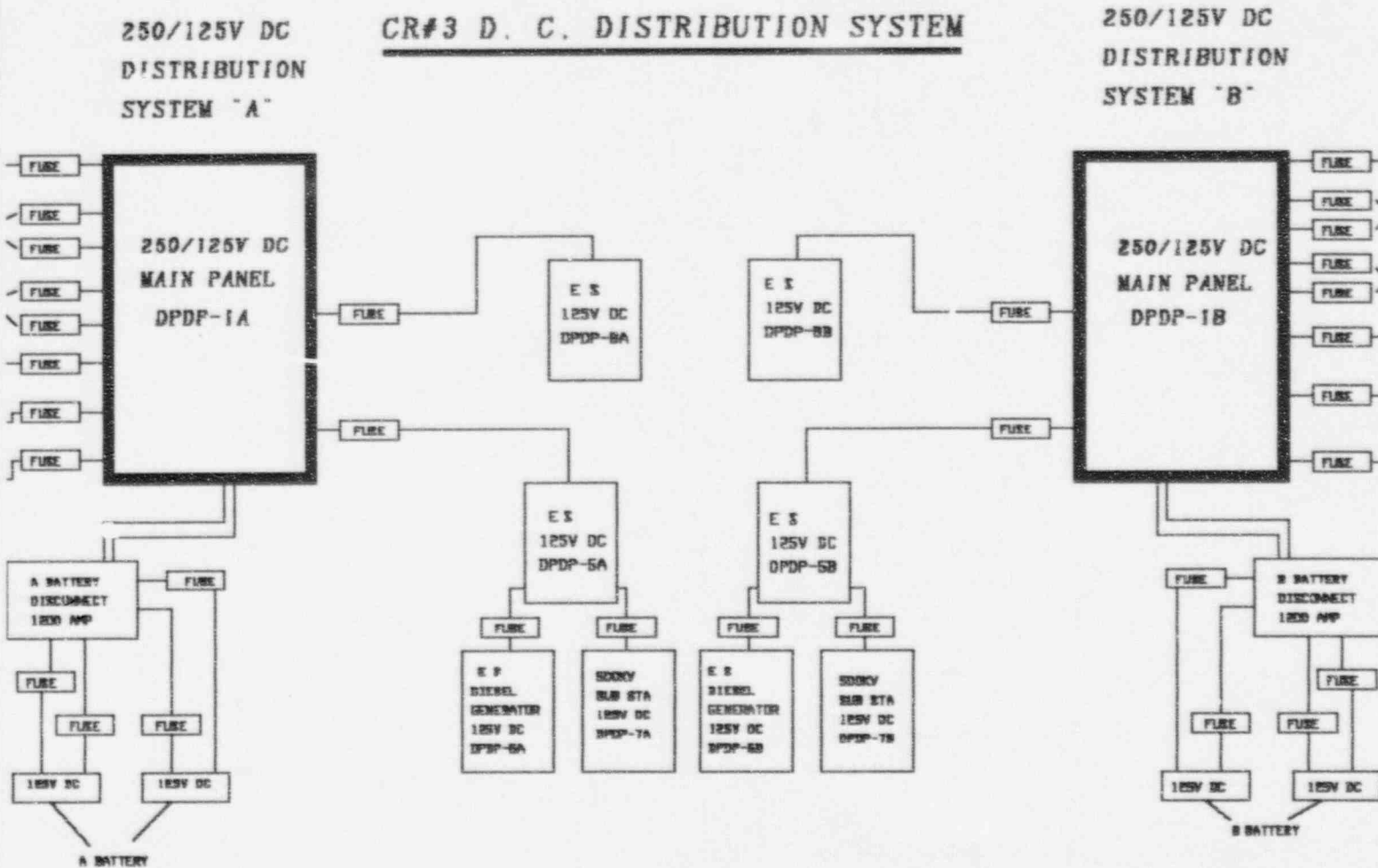

Figure 2: DC Distribution System