

The Cleveland Electric Illuminating Company

PERRY OPERATIONS MANUAL

Process Control Program

INFORMATION
ONLY

TITLE: PROCESS CONTROL PROGRAM (PCP)

REVISION: 6 EFFECTIVE DATE: 11-27-95

PREPARED: Michael Doty *[Signature]* 12-6-94
/ Date

IN-DEPTH REVIEWER: James S. Patterson *[Signature]* 12/8/94
/ Date

PORC REVIEW AND RECOMMENDATION FOR APPROVAL MEETING NUMBER: 94-175
DATE: 12-15-94

APPROVED: John J. Grimm *[Signature]* 3/24/95
/ Date

APPROVED: Jack R. [unclear] *[Signature]* 3/20/95
/ Date

APPROVED: [unclear] *[Signature]* 3/29/95
/ Date

PROCESS CONTROL PROGRAM (PCP)

Table of Contents

<u>Section</u>	<u>Title</u>	<u>Page</u>
1.0	<u>INTRODUCTION</u>	1
1.1	Definitions	1
2.0	<u>WASTE TYPES</u>	2
2.1	Evaporator Concentrates (Bottoms)	2
2.2	Bead Resins	2
2.3	Filter Demineralizer Media Sludge	2
2.4	Traveling Belt Filter Cake	3
2.5	Filter Cartridges	3
2.6	Oily Waste	3
2.7	Dry Active Waste (DAW)	3
2.8	Other Materials	3
3.0	<u>PROCESS DESCRIPTION</u>	3
3.1	Filling of Tanks	3
3.2	Sampling/Analysis	4
3.3	Preconditioning	4
3.4	Mixing Ratios	4
3.5	Dewatering	4
3.6	Solidification Processing	5
3.7	Cartridge Filters	11
3.8	Dry Active Waste	11
3.9	Other Waste Forms and Processes	11
4.0	<u>PRODUCT CONTROL</u>	11
4.1	Test Solidification	12
4.2	Product Quality	12
4.3	Acceptability	12
5.0	<u>WASTE CLASSIFICATION, CHARACTERIZATION AND MANIFEST REQUIREMENTS</u>	13
5.1	Waste Classification	13
5.2	Waste Characteristics and Manifest Requirements	13
6.0	<u>ADMINISTRATIVE CONTROLS</u>	14
7.0	<u>QUALITY ASSURANCE</u>	14
8.0	<u>RECORDS</u>	16
9.0	<u>ATTACHMENTS</u>	16
10.0	<u>REFERENCES</u>	16
10.1	Commitments	16
APPENDIX A	Controls	17
REFERENCES		37

SCOPE OF REVISION:

- Rev. 6 - 1. Revised in its entirety, no rev bars needed.
2. The revision incorporates the procedural details of the RETS, with respect to the PCP, in accordance with the guidelines of G.L. 89-01, and as described in License Amendment Request Letter PY-CEI/NRR-1655L.

PROCESS CONTROL PROGRAM (PCP)

1.0 INTRODUCTION

The Process Control Program (PCP) is designed to provide administrative control and guidance for the solidification, dewatering and other processing of applicable forms of radwaste for ultimate disposal. The PCP contains information pertaining to the current formula (mixing ratio), sampling, analyses, tests, and determinations to be made to ensure that the processing and packaging of radioactive wastes, based on demonstrated processing of actual or simulated wet solid wastes, will be accomplished in such a way as to ensure compliance with 10CFR20, 10CFR61, 10CFR71, Federal and State regulations, burial ground requirements and other requirements governing the disposal of radioactive waste.

The PCP is applicable to the plant installed and Pacific Nuclear Co., Chem-Nuclear and Scientific Ecology Group (SEG) supplied mobile radwaste systems for solidification and dewatering of applicable waste forms. Waste packaged for intermediary processing at offsite vendors shall be prepared for shipment in accordance with the specific vendor's instructions or approved operations manual instructions. All solidifications at Perry will be performed by a vendor with a Topical Report that is accepted by the NRC and destination burial site(s) as meeting all necessary requirements. <B00797>

Numerous features have been incorporated into the design of the solid radioactive waste system and the building housing this system to insure that exposures of operating personnel to radiation will be kept within ALARA guidelines.

Appendix A of the PCP was prepared based on guidance of NUREG-1302 "Offsite Dose Calculation Manual Guidance: Standard Radiological Effluent Controls for Boiling Water Reactors," Generic Letter 89-01, Supplement No. 1. This appendix along with plant procedures will be used by plant personnel to demonstrate compliance with Specification 6.13 (Process Control Program) of the PNPP Technical Specifications.

1.1 Definitions

The following definitions are applicable to the sections that follow:

ACCEPTABLE ENVELOPE: (of solidification\dewatering): specific properties of wastes that fall within the limits of the parameters required for solidification. These parameters are established within the test solidification instruction and/or vendor Topical Report for each applicable waste type. <B00797>

BATCH: the volume of isolated waste contained in a tank that will be processed for solidification or dewatering.

CONTAINER: the physical container in which the final waste product is deposited.

HIGH INTEGRITY CONTAINER (HIC): an approved container for burial having an expected life of 300 years. All HIC's must have an approved Certificate of Compliance.

SOLIDIFICATION: the conversion of radioactive materials from liquid and solid systems to a monolithic, immobilized solid with a definite volume and shape, bounded by a stable surface of distinct outline on all sides (free standing), with a free water content of less than 0.5% by volume.

2.0 WASTE TYPES

There are numerous types of radioactive waste expected to be generated at the Perry Plant that will require processing, including solidification or dewatering, prior to their disposal. These radwaste types can be categorized based on their chemical and physical properties. The waste types expected at PNPP are evaporator concentrates (bottoms), bead resins, filter demineralizer media sludge, traveling belt filter cake, filter cartridges, oily waste, and dry active waste (DAW).

The following waste types (other than DAW) may be solidified/dewatered individually or in combination, with the provision that the chemistry of the waste falls within the acceptable envelope for solidification/dewatering.

2.1 Evaporator Concentrates (Bottoms)

Evaporator concentrates (bottoms) result from the processing of the chemical waste tanks which contain condensate demineralizer regeneration solutions and/or low concentrations of the following: trisodium phosphate, minute amounts of other chemicals used for chemistry analyses, or decontamination solutions. They will normally be in the range of 5% to 25% sodium sulfate by weight.

2.2 Bead Resins

Bead resins are collected from the condensate, liquid radwaste, and suppression pool demineralizers and stored in the spent resin tank. Bead resins are also collected from chemical decontamination processes.

2.3 Filter Demineralizer Media Sludge

Sludge is the waste product generated by the backwash of the condensate filters, the reactor water cleanup filter/demineralizers, and the fuel pool filter/demineralizers. Sludge may consist of powdered ion exchange resin at varying degrees of exhaustion, fibrous filter media, and small concentrations of various solids and corrosion products. The media are decanted prior to solidification/dewatering in the appropriate settling tank.

2.4 Traveling Belt Filter Cake

This is the product remaining on the liquid radwaste traveling belt filters used to process waste water streams. It consists of one or more of the following; diatomaceous earth or powdered resin, various solids, dirt, and corrosion products in small concentrations.

2.5 Filter Cartridges

Filter cartridges from the detergent drain tank system, CRD pump suction and discharge filters, and any other disposable-type filter cartridge, or non metallic filter septa, that may be used in permanent or temporary, plant or vendor systems are included in this category.

2.6 Oily Waste

Oily waste is that oil collected in liquid radwaste systems as a result of leakage and maintenance on various lubrication and hydraulic systems.

2.7 Dry Active Waste (DAW)

Contaminated air filters, paper, rags, clothing, tools, equipment and parts, that cannot be effectively decontaminated are contained in this category. Also included are laboratory wastes.

2.8 Other Materials

Various other materials not specifically identified above, will be evaluated for solidification, dewatering, or other process on a case-by-case basis.

3.0 PROCESS DESCRIPTION

The following process descriptions apply to both plant and vendor supplied systems. Any differences between the two have been noted.

3.1 Filling of Tanks

Once it is determined that a liquid radwaste system batch tank is to be processed, it will be recirculated to ensure a homogeneous mixture. Eductors inside the tanks enhance the mixing capabilities. The tank will be isolated using the plant's tagout program to ensure that no additional waste is added.

3.2 Sampling/Analysis

Samples will be obtained and analyzed for each batch of waste in accordance with OM12C: CHI-42, OM12A: CHI-78, and OM1A: PAP-1102, respectively for the plant system, or vendor procedures and PCP for vendor supplied systems. Prior to sampling, tanks will undergo sufficient mixing and/or recirculation to ensure representative sampling. At a minimum, for solidification, analyses will be performed for radionuclide content, pH, oil content, and settled solids (oil and concentrates only). At a minimum, for dewatering, analyses will be performed for radionuclide and oil content. These analyses are necessary to ensure that the waste falls within the acceptable envelopes for solidification/dewatering.

3.3 Preconditioning

Waste preconditioning is the chemical or physical adjustment of the waste to bring it within an established acceptability envelope to ensure solidification. The need for and type of preconditioning shall be determined using sample analysis results and will be performed in accordance with OM12A: CHI-78 or vendor procedures and PCP. Upon completion of waste preconditioning, additional samples shall be obtained, as required, to determine solidification mixing ratios.

Oily wastes may require special preconditioning. Handling of oily wastes will be conducted in accordance with burial ground requirements.

Preconditioning may also be performed on waste streams which are or will be dewatered to eliminate or reduce bacterial activity in the waste. Preconditioning of waste streams for this purpose will be conducted in accordance with approved site and/or vendor procedures.

3.4 Mixing Ratios

Mixing ratios give the respective amounts of waste and solidification agents required for acceptable solidification. The determination of mixing ratios shall be performed for each batch of waste to be solidified. Solidification mixing ratios are dependent upon percent settled solids and sodium sulfate concentration. The waste type and ratios of cement, waste, sodium sulfate (for Class A waste), and water are determined in OM12A: CHI-78 or vendor procedures and PCP.

3.5 Dewatering

Dewatering is the removal of water from solid material to a concentration of less than 0.5% or 1.0% by volume, as applicable to containers used and burial site limits. Dewatering of radioactive spent resins, filter sludges and traveling belt filter cake shall be performed in accordance with approved operating procedures which are based upon documented test data demonstrating the ability to achieve drainable water limits as specified in applicable regulations.

3.6 Solidification Processing

3.6.1 Description of Plant Processing System

Solidification and/or dewatering of wet solid radioactive waste will be processed by Chem-Nuclear's Rapid Dewatering System, NUPAC Services Division's Resin Drying System or by SEG's Mobile System. These systems are discussed in Section 3.6.2. The following description applies to the plant installed solid radwaste system that will interface with the vendor equipment (See Figure 1).

(INTENTIONALLY BLANK)

Solid Radioactive Waste Processing System

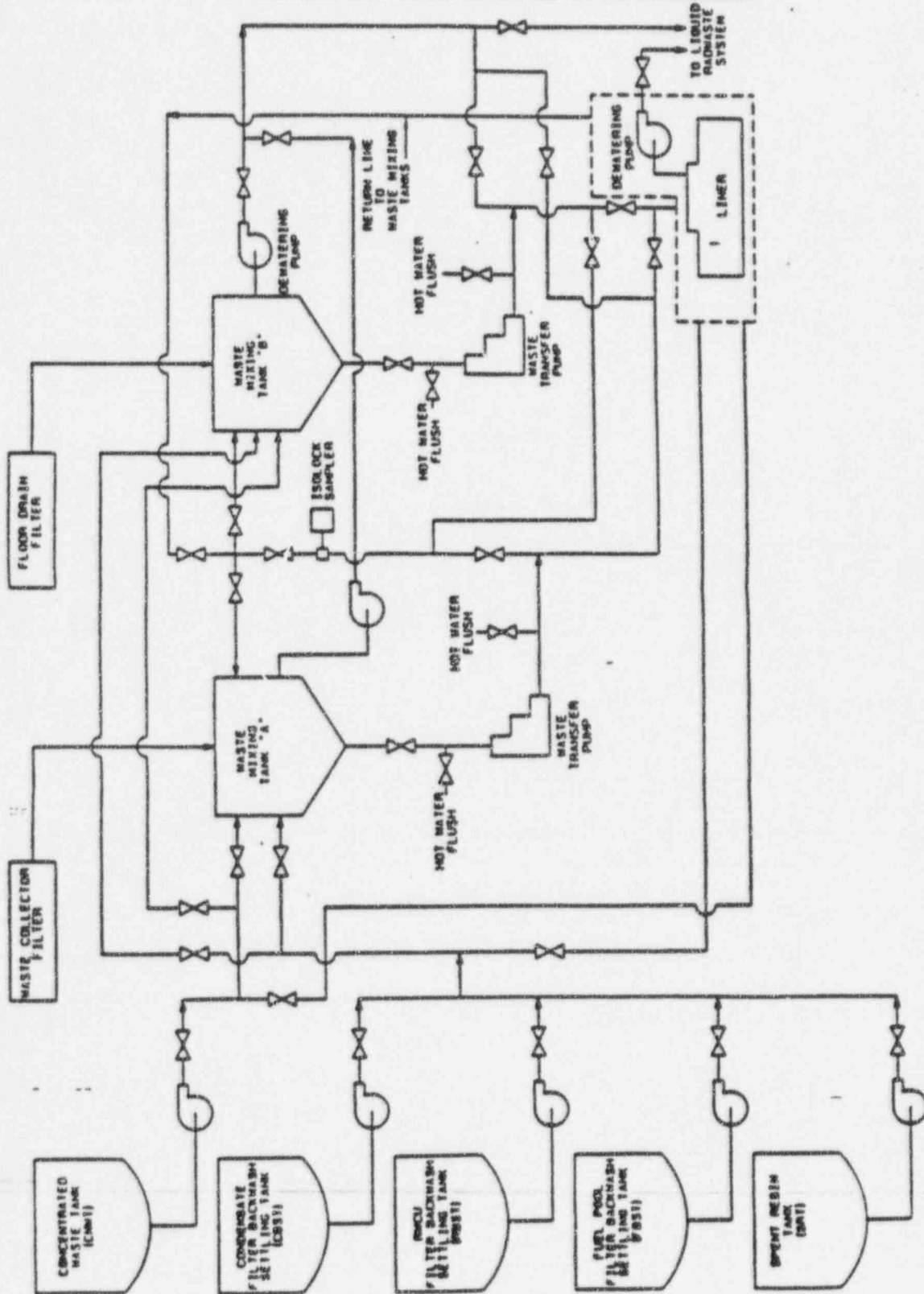

Figure 1

After the proper amount of waste has been accumulated in a settling or waste tanks or has been transferred to the waste mixing tank, the tank is decanted to remove excess free water (except when the waste being handled is traveling belt filter cake, in which case a predetermined amount of water or other approved aqueous solution is added to the tank for slurry transfer of the contents). The waste slurry is transferred at a preset rate to the vendor's equipment, in accordance with OM13A: RWI-G51-(SRW), where it is either dewatered or solidified with cement. The waste mixing tanks and settling tanks have recirculation capabilities where a representative sample can be drawn. If needed, a dewatering connection is available which is routed to the liquid radwaste system. An additional connection has been provided back to the waste mixing tank for use in the event of a liner overflow condition. Hot water flush connections are provided to thoroughly flush the plant and the vendor equipment into the liner used for processing. The waste transfer line and dewatering return lines are located behind a two foot thick shield wall to reduce exposure to the operator during processing.

3.6.2 Description of the Vendor's Waste Processing System

The wet solid radioactive waste will be transferred to the vendor's equipment to be dewatered or solidified in accordance with site approved procedures. Table 1 lists the Topical Reports, procedures and any comments for each vendor.

The vendor's equipment is located in the Radwaste Building in the fill aisle, storage area, and truck bay (see Figure 2). Normal processing of radioactive waste will be performed in the fill aisle with only the vendor's cement transfer equipment being located in the cement silo room. Periodically, when determined prudent, waste will be processed in the truck bay. When this is performed several restrictions will be imposed to minimize the potential for radioactive spill and ensure the principles of ALARA are maintained. These include; all processing to be performed in a High Integrity Container (HIC) placed inside an NRC Approved cask, all hosing and associated connections to be placed in hose bags, truck bay access doors to have temporary curbing placed in front of them, and locking all access areas to the truck bay. The areas where the processing takes place are specifically designed to handle the movement, storage, and processing of radioactive waste. Concrete walls and floors in these areas have protective coatings and shield/ cask walls are provided between the vendors equipment and potential radioactive sources to keep personnel exposures ALARA. The storage area is large enough to contain 15 liners. This provides adequate storage before it is shipped to a burial site, or transferred to the On Site Storage Area.

Vendor Procedures for Radwaste Processing

<u>Vendor</u>	<u>Topical Report</u>	<u>Operating Procedures</u>	<u>Comments</u>
Chem-Nuclear	Radioactive Waste Dewatering System, RDS-25506-01-P-A	Setup and Operating Procedure for the RDS-1000 Unit, FO-OP-032	1. Test solidifications will be run on each batch of the same waste type.
	Mobile Cement Solidification System, CNSI-2	Operating Procedure for the Mobile Cement Solidification Unit No. 221, SD-OP-050	
Pacific-Nuclear	Nuclear Packaging Dewatering System, TP-02-P-A	Resin Drying (Dewatering) System, OM-43-NS	
	Pacific Nuclear Systems Radwaste Solidification System, TP-05	Operation and Maintenance Manual for the NUPAC Radwaste Solidification System, OM-114	1. Test solidifications will be run on each batch of the same waste type.
		System Description of Pacific Nuclear System's Radioactive Waste Volume Reduction System RVR-800	
		Operation Procedure for RVR-800 Liquid Volume Reduction System, OM-0022-NS	
Scientific Ecology Group	Stock Equipment Co. Quick Dry Process for Dewatering of Bead Resin and Filter Sludge, SRS-003	Process Control Program for Dewatering Bead or Powdered Resin with Quick Dry Dewatering System No. 2893, DW-004	1. Test solidifications will be run on each batch of the same waste type.
	Radwaste Solidification System, PS-53-0378	SEG Solidification System, SS-001	2. Waste will be supplied to the SEG equipment at 20 gpm instead of 40 gpm due to pump limitations.

Table 1

PCP
Page: 8
Rev.: 6

Vendor Mobile Solidification Equipment Layout

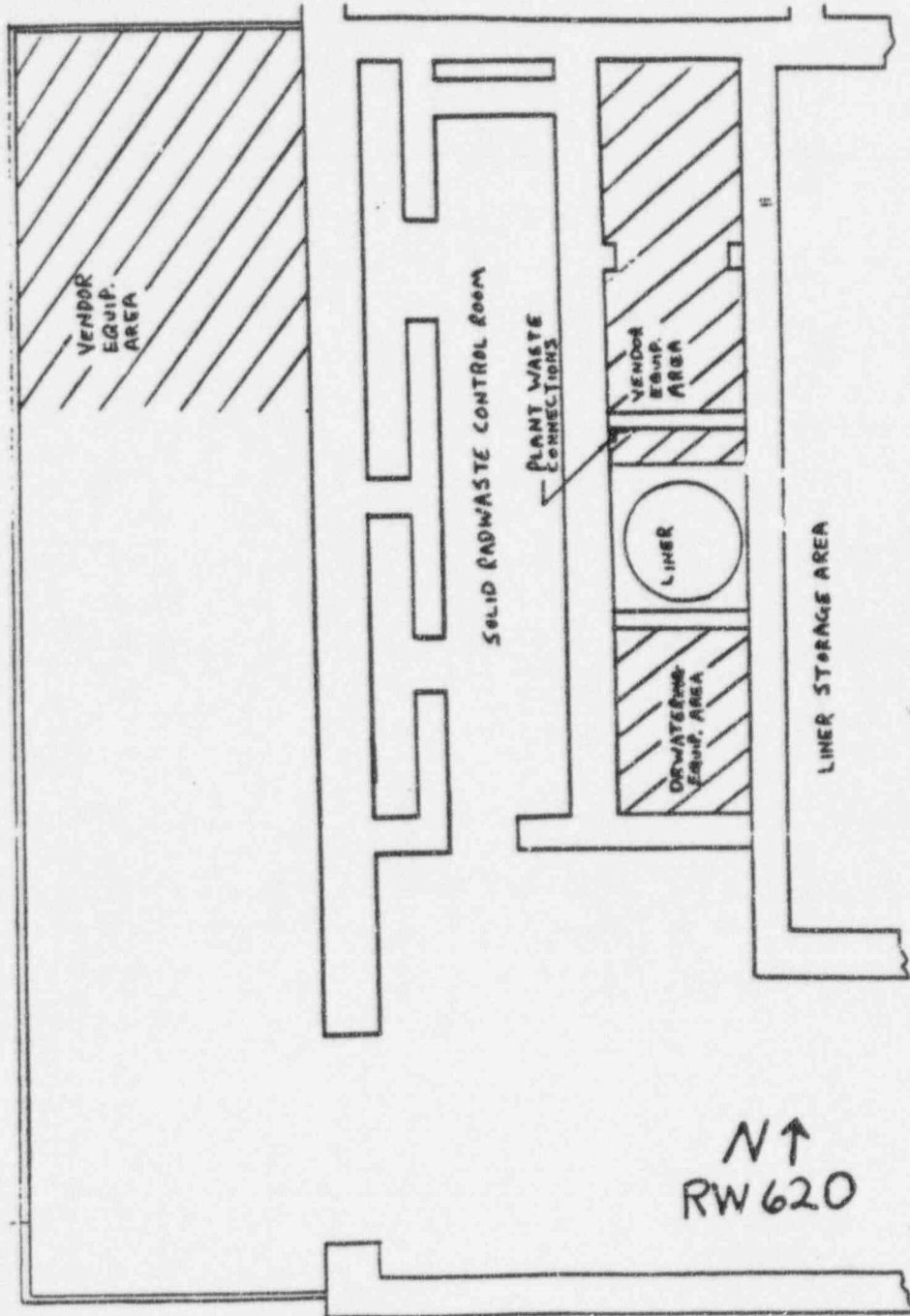

Figure 2

3.6.3 Radiological Effluent Controls and Monitoring

All processing with the vendor's equipment will be performed in a room with a volume sufficient to contain any postulated spill. A floor drain, routed to the liquid radwaste system, provides drainage in this area. All liquid radwaste discharges are sampled and monitored prior to their release to the environment.

Gaseous discharges from liners are processed through the vendor's off-gas blower system as described in the vendor's Topical Report. Ventilation from the areas housing the radwaste treatment and processing equipment, including the vendor's off-gas blower system, is routed through HEPA filters and charcoal beds prior to release to the environment via the Unit 1 Vent. Radiological monitoring is provided for Regulatory Guide 1.21 compliance to meet applicable Federal Code requirements.

3.6.4 Health Physics Support

Health Physics personnel will provide radiological control during the solidification and dewatering process. All work will be conducted under a Radiation Work Permit to keep personnel exposures ALARA.

3.6.5 Plant Utility Support

1. Fire Protection

Fire suppression is provided above the processing and storage area to protect against fires. A fire hose is available in the truck bay for miscellaneous uses.

2. Two-Way Communication

A two-way communication system will be used for communication between the plant operator and the vendor equipment operator. This will facilitate smooth coordination between the different segments of the waste processing system.

3. Heating and Ventilation

The Radwaste Building Ventilation System will maintain a negative pressure in the processing and storage area. Heating is provided by the building heating system.

4. Overhead Crane

An overhead crane will be used to transfer equipment between the storage and processing area and the truck bay. The crane has a 15 ton capacity which is fully capable of handling dewatered and solidified liners.

5. Closed Circuit Television

Closed Circuit Television will be used, where applicable, for remote viewing of the processing and storage areas. The overhead crane has an independent camera for viewing all lifting and placing operations.

3.7 Cartridge Filters

Cartridge filters may be disposed of by encapsulation in a cement matrix in steel drums or liners. The encapsulation of cartridge filters shall be performed using approved procedures that provide reasonable assurance that the final waste form will meet the stability criteria of the Branch Technical Position on Waste Form. Cartridge filters may also be disposed of by placement in HIC's that are certified by the land disposal facility's State Agency.

3.8 Dry Active Waste

Potentially contaminated dry wastes will be collected in containers located throughout the radiologically controlled areas within the plant. The waste will be periodically collected and transported to a temporary storage area prior to waste segregation (as per OM1A: PAP-1901). Waste segregation will be performed to reduce waste volume and to recover reusable materials.

In order to reduce the waste volume, compressible waste will be compacted into shipping containers in accordance with OM13A: RWI-G51-(SRWC). Caution will be taken to avoid items that would cause free water formation as well as other compressibility hazards. Noncompressible waste will be loaded manually into suitable shipping containers.

3.9 Other Waste Forms and Processes

Waste forms and/or processes not previously discussed shall have an approved PNPP or vendor procedure to govern the process.

4.0 PRODUCT CONTROL

Dewatering/Solidification processes will be conducted by qualified PNPP or vendor personnel in accordance with approved plant and/or vendor operating instructions and procedures.

PAP-0525, Solid Radwaste Administration will ensure appropriate documentation and compliance with this program.

4.1 Test Solidification

Test solidifications are performed on waste stream samples to verify plant and/or vendor calculated solidification formulae. Test shall be performed to support solidification mixing formulae as follows:

(1) every batch of the same waste type; (2) when sampling analysis falls outside the normal established envelope and preconditioning is ineffective, (3) following any liner of the same waste type where solidification has been determined to be unacceptable; (4) when it is believed that some unexpected or abnormal containment may be present; or (5) when requested by Chemistry Supervision. A batch that requires test solidification shall not be processed until such time as the test solidification proves acceptable. <L00415>

Upon failure of a test solidification, additional samples shall be obtained and testing will continue until a successful solidification has been performed with revised mixing ratios as determined by Chemistry Supervision. Solidification of the batch may then be continued using the alternate solidification parameters defined by testing. All solidifications at Perry will be performed by a vendor with a Topical Report that is accepted by the NRC and destination burial site(s) as meeting all necessary requirements. <B00797>

4.2 Product Quality

Solidification process product quality shall be ensured by the use of predetermined mixing ratios of waste and solidification agents. Mixing ratios are based upon laboratory testing of non-radioactive waste materials and are supported by (1) the test solidifications performed periodically, as mentioned above; (2) periodic checks, visual and physical, of actual processed containers filled with solidified waste; and (3) once every two years requalification of the waste form. Requalification includes testing for compressibility in accordance with ASTM C-39-84, following an appropriate immersion period.

4.3 Acceptability

The acceptability of the solidified product shall be verified by ensuring that less than 0.5% free standing water exists and that the solidified product appears to be able to hold its shape if it were to be removed from the container.

Unacceptable solidified waste shall be handled as follows: (1) if the reason for unacceptability is free standing water, the free standing water will be removed or extra cement/sodium silicate will be added to solidify the free water; (2) if all or portions of the product did not solidify, the waste container will be capped and placed in a storage location in the Radwaste facility and periodically checked until such time that the product is acceptable or it is determined that additional solidification agents can be added to achieve satisfactory solidification. This will be determined by Chemistry Supervision. The handling of unacceptable solidified waste will be on a case-by-case basis.

Adherence to approved dewatering operating procedures ensure the final product will meet or exceed the standing water requirements of 10CFR61.

Dewatering of radioactive bead resin, filter demineralizer media sludge, and traveling belt filter cake shall be performed in accordance with approved operating procedures which are based upon documented test data demonstrating the ability to remove free water volumes below the applicable regulatory limits.

5.0 WASTE CLASSIFICATION, CHARACTERIZATION AND MANIFEST REQUIREMENTS

5.1 Waste Classification

All wastes shall be classified in accordance with the requirements of 10CFR61 as implemented by OM1A: PAP-1309 and OM1E: RAP-1102 and performed by the RADMAN computer code. Analyses shall be performed on the waste streams at least annually (biannually for Class A waste), to determine the isotopic abundance of non-gamma emitting isotopes in the streams. Scaling factors, for the non-gamma emitting and transuranic constituents, will be developed from these analyses. Prior to the establishment of an acceptable data, estimated isotopic concentrations will be those obtained from the "Data Base Analysis Report" prepared by Waste Management Group.

The activity of each radionuclide in the radioactive waste shall be determined by a calculational method employing the isotopic analysis of the waste and scaling factors or a dose-to-curie conversion as to be determined by RPS supervision. For DAW, a dose-to-curie conversion factor, percent fraction of the radionuclides, and scaling factors will be used to determine activity.

5.2 Waste Characteristics and Manifest Requirements

All wastes shall meet the characteristic requirements of 10CFR61.56 (a) and (b), as applicable, and waste packages shall be marked to identify the waste class. The manifesting requirements of 10CFR20.2006 shall be implemented by OM1A: PAP-1309 and performed by the RADMAN computer code. Records are maintained in accordance with 10CFR71.91.

6.0 ADMINISTRATIVE CONTROLS

Compliance with applicable state and federal regulations, and with burial site criteria is ensured by compliance with the solid radioactive waste surveillance instructions, OM7A: SVI-G51-T5284.

The implementing instructions and procedures for radioactive waste solidification, dewatering, and segregation describe the requirements which must be met prior to processing radioactive waste, as well as the expected condition of the resultant waste form. Test solidifications, full scale calculations and operation of solidification, dewatering and segregation equipment shall be performed by qualified plant staff and vendor personnel. Plant staff personnel shall provide Health Physics and Quality Assurance coverage, operate plant radioactive waste systems, collect waste stream samples, and perform isotopic analyses. Copies of all referenced documents are available onsite for use by personnel engaged in waste processing activities.

Any changes to the Process Control Program shall be reviewed by the Plant Operations Review Committee (PORC) and shall be detailed in the Annual Radioactive Effluent Release Report covering that period.

7.0 QUALITY ASSURANCE

Quality Assurance related activities for the solid radwaste program are implemented as described in the Perry Nuclear Power Plant Quality Assurance Plan. To prevent unacceptable solidified waste from being released for shipment, test samples will be verified for acceptability by Chemistry Supervision. These activities shall provide verification that all solid radioactive waste meets applicable State and Federal regulations and burial site criteria. A flow chart illustrating the sequence of events for a waste solidification process is provided in Figure 3.

The Quality Assurance Plan also includes a management review of vendor's Topical Report. This will ensure that the vendor's operations and requirements are compatible with the responsibilities and operations of the plant.

Training and qualification of operators will be performed per Regulatory Guide 1.8 and ANSI N18.1 - 1971.

For accountability of filled waste containers, a clearly legible storage diagram will be permanently displayed near the radwaste control panel. It will show the position of containers holding wastes, the date the wastes were processed, and their dose rate(s). The storage diagram will be updated to reflect any changes, additions, or deletions to storage.

Radwaste Process Flow Chart

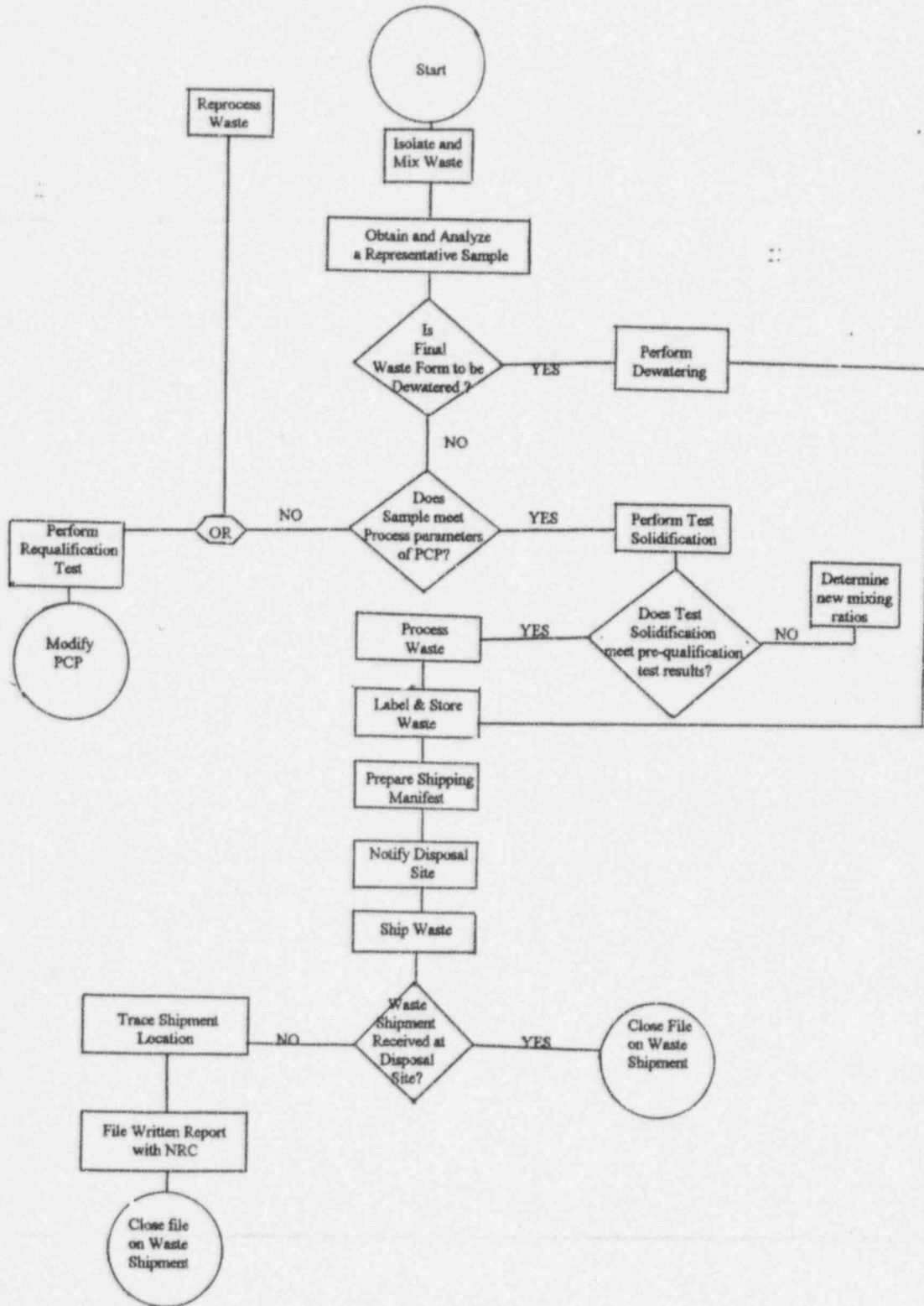

Figure 3

8.0 RECORDS

The following records are generated by this program:

Quality Assurance Records

None

Non Quality Records

None

9.0 ATTACHMENTS

None

10.0 REFERENCES

10.1 Commitments

The following commitments are wholly or in part met by this document:

B00301 F01412 F01464 L00415 S00245 B00797

APPENDIX A

Controls

INDEX

DEFINITIONS

SECTION

<u>1.0 DEFINITIONS</u>	<u>PAGE</u>
1.1 ACTION.....	1-1
1.26 MEMBER(S) OF THE PUBLIC.....	1-1
1.28 OFFSITE DOSE CALCULATION MANUAL.....	1-1
1.29 OPERABLE - OPERABILITY.....	1-1
1.30 OPERATIONAL CONDITION - CONDITION.....	1-1
1.34 PROCESS CONTROL PROGRAM.....	1-2
1.42 SITE BOUNDARY.....	1-2
1.43 SOLIDIFICATION.....	1-2
1.49 UNRESTRICTED AREA.....	1-2

CONTROLS AND SURVEILLANCE REQUIREMENTS

3/4.0 APPLICABILITY.....	3/4 0-1
<u>3/4.11 RADIOACTIVE EFFLUENTS</u>	
3/4.11.3 SOLID RADWASTE TREATMENT.....	3/4 2-1

BASES

3/4.0 APPLICABILITY.....	B 3/4 0-1
<u>3/4.11.3 SOLID RADIOACTIVE WASTE.....</u>	B 3/4 3-1

ADMINISTRATIVE CONTROLS

6.9.1.7 ANNUAL RADIOACTIVE EFFLUENT RELEASE REPORT.....	4-1
6.15 MAJOR CHANGES TO RADIOACTIVE WASTE TREATMENT SYSTEMS.....	4-2

DEFINITIONS

The following terms are defined so that uniform interpretation of these Control may be achieved. The defined terms appear in capitalized type and be applicable throughout these Controls.

ACTION

1.1 ACTION shall be that part of a Control which prescribes remedial measures required under designated conditions.

MEMBER(S) OF THE PUBLIC

1.26 MEMBER(S) OF THE PUBLIC shall include all persons who are not occupationally associated with the plant. This category does not include employees of the utility, its contractors, or vendors. Also excluded from this category are persons who enter the site to service equipment or to make deliveries. This category does include persons who use portions of the site for recreational, occupational, or other purposes not associated with the plant.

OFFSITE DOSE CALCULATION MANUAL (ODCM)

1.28 The OFFSITE DOSE CALCULATION MANUAL shall contain the methodology and parameters used in the calculation of offsite doses due to radioactive gaseous and liquid effluents, in the calculation of gaseous and liquid effluent monitoring alarm/trip setpoints, and in the conduct of the radiological environmental monitoring program.

The ODCM shall also contain (1) the Radioactive Effluent Controls and Radiological Environmental Monitoring Programs required by Specification 6.8.4 and (2) descriptions of the information that should be included in the Annual Radiological Environmental Operating and Annual Radioactive Effluent Release Reports required by Specifications 6.9.1.6 and 6.9.1.7.

OPERABLE - OPERABILITY

1.29 A system, subsystem, train, component or device shall be OPERABLE or have OPERABILITY when it is capable of performing its specified function(s) and when all necessary attendant instrumentation, controls, electrical power, cooling or seal water, lubrication or other auxiliary equipment that are required for the system, subsystem, train, component or device to perform its function(s) are also capable of performing their related support function(s).

OPERATIONAL CONDITION - CONDITION

1.30 An OPERATIONAL CONDITION, i.e., CONDITION, shall be any one inclusive combination of mode switch position and average reactor coolant temperature as specified in Table 1.2.

PROCESS CONTROL PROGRAM (PCP)

1.34 The PROCESS CONTROL PROGRAM shall contain the current formulas, sampling, analyses, tests, and determinations to be made to ensure that the processing and packaging of solid radioactive wastes based on demonstrated processing of actual or simulated wet solid wastes will be accomplished in such a way as to assure compliance with 10 CFR Part 20, 10 CFR Part 61, 10 CFR Part 71 and Federal and State regulations, burial ground requirements and other requirements governing the disposal of the radioactive waste.

SITE BOUNDARY

1.42 The SITE BOUNDARY shall be that line beyond which the land is neither owned, nor leased, nor otherwise controlled by the licensee.

SOLIDIFICATION

1.43 SOLIDIFICATION shall be the conversion of wet wastes into a form that meets shipping and burial ground requirements.

UNRESTRICTED AREA

1.49 An UNRESTRICTED AREA shall be any area at or beyond the SITE BOUNDARY access to which is not controlled by the licensee for purposes of protection of MEMBERS OF THE PUBLIC from exposure to radiation and radioactive materials, or any area within the SITE BOUNDARY used for residential quarters or for industrial, commercial, institutional, and/or recreational purposes.

TABLE 1.1

SURVEILLANCE FREQUENCY NOTATION

<u>NOTATION</u>	<u>FREQUENCY</u>
S	At least once per 12 hours.
D	At least once per 24 hours.
W	At least once per 7 days.
M	At least once per 31 days.
Q	At least once per 92 days.
SA	At least once per 184 days.
A	At least once per 366 days.
R	At least once per 18 months (550 days).
S/U	Prior to each reactor startup.
P	Completed prior to each release.
N.A.	Not applicable.

TABLE 1.2

OPERATIONAL CONDITIONS

<u>CONDITION</u>	<u>MODE SWITCH POSITION</u>	<u>AVERAGE REACTOR COOLANT TEMPERATURE</u>
1. POWER OPERATION	RUN	Any temperature
2. STARTUP	Startup/Hot Standby**	Any temperature
3. HOT SHUTDOWN	Shutdown#,***	> 200 °F
4. COLD SHUTDOWN	Shutdown#,##,***	≤ 200 °F
5. REFUELING*	Shutdown or Refuel**,#	≤ 140 °F

#The reactor mode switch may be placed in the Run, Startup/Hot Standby, or Refuel position to test the switch interlock functions and related instrumentation provided that the control rods are verified to remain fully inserted by a second licensed operator or other technically qualified member of the unit technical staff.

##The reactor mode switch may be placed in the Refuel position while a single control rod drive is being removed from the reactor pressure vessel per PNPP Unit 1 Technical Specification 3.9.10.1.

*Fuel in the reactor vessel with the vessel head closure bolts less than fully tensioned or with the head removed.

**See Special Test Exceptions 3.10.1 and 3.10.3 in PNPP Unit 1 Technical Specifications.

***The reactor mode switch may be placed in the Refuel position while a single control rod is being recoupled or withdrawn provided that the one-rod-out interlock is OPERABLE.

3/4.0 APPLICABILITY

CONTROLS

3.0.1 Compliance with the Controls contained in the succeeding controls is required during the OPERATIONAL CONDITIONS or other conditions specified therein; except that upon failure to meet the Control, the associated ACTION requirements shall be met.

3.0.2 Noncompliance with a control shall exist when the requirements of the Control and associated ACTION requirements are not met within the specified time intervals. If the Control is restored prior to expiration of the specified time intervals, completion of the Action requirements is not required.

3.0.3 When a Control is not met, except as provided in the associated ACTION requirements, within one hour action shall be initiated to place the unit in an OPERATIONAL CONDITION in which the control does not apply by placing it, as applicable, in:

1. At least STARTUP within the next 6 hours,
2. At least HOT SHUTDOWN within the following 6 hours, and
3. At least COLD SHUTDOWN within the subsequent 24 hours.

Where corrective measures are completed that permit operation under the ACTION requirements, the ACTION may be taken in accordance with the specified time limits as measured from the time of failure to meet the Control. Exceptions to these requirements are stated in the individual controls.

This control is not applicable in OPERATIONAL CONDITIONS 4 or 5.

3.0.4 Entry into an OPERATIONAL CONDITION or other specified condition shall not be made when the conditions for the Control are not met and the associated ACTION requires a shutdown if they are not met within a specified time interval. Entry into an OPERATIONAL CONDITION or other specified condition may be made in accordance with the ACTION requirements when conformance to them permits continued operation of the facility for an unlimited period of time. This provision shall not prevent passage through or to OPERATIONAL CONDITIONS as required to comply with ACTION requirements. Exceptions to these requirements are stated in the individual controls.

APPLICABILITY

SURVEILLANCE REQUIREMENTS

4.0.1 Surveillance Requirements shall be met during the OPERATIONAL CONDITIONS or other conditions specified for individual Controls unless otherwise stated in an individual Surveillance Requirement.

4.0.2 Each Surveillance Requirement shall be performed within the specified surveillance interval with a maximum allowable extension not to exceed 25 percent of the specified surveillance interval.

4.0.3 Failure to perform a Surveillance Requirement within the allowed surveillance interval, defined by control 4.0.2, shall constitute noncompliance with the OPERABILITY requirements for a Control. The time limits of the ACTION requirements are applicable at the time it is identified that a Surveillance Requirement has not been performed. The ACTION requirements may be delayed for up to 24 hours to permit the completion of the surveillance when the allowable outage time limits of the ACTION requirements are less than 24 hours. Surveillance Requirements do not have to be performed on inoperable equipment.

4.0.4 Entry into an OPERATIONAL CONDITION or other specified applicable condition shall not be made unless the Surveillance Requirement(s) associated with the Control have been performed within the applicable surveillance interval or as otherwise specified. This provision shall not prevent passage through or to OPERATIONAL CONDITIONS as required to comply with ACTION requirements.

RADIOACTIVE EFFLUENTS

3/4.11.3 SOLID RADWASTE TREATMENT

CONTROLS

3.11.3 In accordance with Perry Nuclear Power Plant Unit 1 TS 1.34, radioactive wastes shall be SOLIDIFIED or dewatered in accordance with the PROCESS CONTROL PROGRAM to meet shipping and transportation requirements during transit, and disposal site requirements when received at the disposal site.

APPLICABILITY: At all times.

ACTION:

- a. With SOLIDIFICATION or dewatering not meeting disposal site and shipping and transportation requirements, suspend shipment of the inadequately processed wastes and correct the PROCESS CONTROL PROGRAM, the procedures and/or the solid waste system as necessary to prevent recurrence.
- b. With the SOLIDIFICATION or dewatering not performed in accordance with the PROCESS CONTROL PROGRAM, (1) test the improperly processed waste in each container to ensure that it meets burial ground and shipping requirements and (2) take appropriate administrative action to prevent recurrence.
- c. The provisions of Control 3.0.3 are not applicable.

SURVEILLANCE REQUIREMENTS

4.11.3.1 If the SOLIDIFICATION method is used, the PROCESS CONTROL PROGRAM shall be used to verify the SOLIDIFICATION of at least one representative test specimen from at least every tenth batch of each type of wet radioactive waste (e.g., filter sludges, spent resins, evaporator bottoms, and sodium sulfate solutions).

- a. If any test specimen fails to verify SOLIDIFICATION, the SOLIDIFICATION of the batch under test shall be suspended until such time as additional test specimens can be obtained, alternative SOLIDIFICATION parameters can be determined in accordance with the PROCESS CONTROL PROGRAM, and a subsequent test verifies SOLIDIFICATION. SOLIDIFICATION of the batch may then be resumed using the alternative SOLIDIFICATION parameters determined by the PROCESS CONTROL PROGRAM.

RADIOACTIVE EFFLUENTS

SURVEILLANCE REQUIREMENTS (Continued)

- b. If the initial test specimen from a batch of waste fails to verify SOLIDIFICATION, the PROCESS CONTROL PROGRAM shall provide for the collection and testing of representative test specimens from each consecutive batch of the same type of wet waste until at least three consecutive initial test specimens demonstrate SOLIDIFICATION. The PROCESS CONTROL PROGRAM shall be modified as required, as provided in Perry Nuclear Power Plant Unit 1 TS 6.13, to assure SOLIDIFICATION of subsequent batches of waste.

- c. With the installed equipment incapable of meeting Control 3.11.3 or declared inoperable, restore the equipment to OPERABLE status or provide the contract capability to process wastes as necessary to satisfy all applicable transportation and disposal requirements.

BASES FOR
SECTIONS 3.0 AND 4.0
CONTROLS
AND
SURVEILLANCE REQUIREMENTS

NOTE

The BASES contained in succeeding pages summarize the reasons for the Controls in Section 3.0 and 4.0, but are not part of these Controls.

3/4 CONTROLS AND SURVEILLANCE REQUIREMENTS

3/4.0 APPLICABILITY

BASES

Controls 3.0.1 through 3.0.4 establish the general requirements applicable to the Appendix C Controls. These requirements are derived from the requirements for Limiting Conditions for Operation stated in the Code of Federal Regulations, 10 CFR 50.36(c)(2) for plant Technical Specifications.

Control 3.0.1 establishes the Applicability statement within each individual control as the requirement for when (i.e., in which OPERATIONAL CONDITIONS or other specified conditions) conformance to the Control is required for safe operation of the facility. The ACTION requirements establish those remedial measures that must be taken within specified time limits when the requirements of a Control are not met. It is not intended that the shutdown ACTION requirements be used as an operational convenience which permits (routine) voluntary removal of a system(s) or component(s) from service in lieu of other alternatives that would not result in redundant systems or components being inoperable.

There are two basic types of ACTION requirements. The first specifies the remedial measures that permit continued operation of the facility which is not further restricted by the time limits of the ACTION requirements. In this case, conformance to the ACTION requirements provides an acceptable level of safety for unlimited continued operation as long as the ACTION requirements continue to be met. The second type of ACTION requirement specifies a time limit in which conformance to the conditions of the Control must be met. This time limit is the allowable outage time to restore an inoperable system or component to OPERABLE status or for restoring parameters within specified limits. If these actions are not completed within the allowable outage time limits, a shutdown is required to place the facility in an OPERATIONAL CONDITION or other specified condition in which the control no longer applies.

The specified time limits of the ACTION requirements are applicable from the point in time it is identified that a Control is not met. The time limits of the ACTION requirements are also applicable when a system or component is removed from service for surveillance testing or investigation of operational problems. Individual controls may include a specified time limit for the completion of a Surveillance Requirement when equipment is removed from service. In this case, the allowable outage time limits of the ACTION requirements are applicable when this limit expires if the surveillance has not been completed. When a shutdown is required to comply with ACTION requirements, the plant may have entered an OPERATIONAL CONDITION in which a new control becomes applicable. In this case, the time limits of the ACTION requirements would apply from the point in time that the new control becomes applicable if the requirements of the Control are not met.

3/4.0 APPLICABILITY

BASES (Continued)

Control 3.0.2 establishes that noncompliance with a control exists when the requirements of the Control are not met and the associated ACTION requirements have not been implemented within the specified time interval. The purpose of this control is to clarify that (1) implementation of the ACTION requirement within the specified time interval constitutes compliance with a control, and (2) completion of the remedial measures of the ACTION requirements is not required when compliance with a Control is restored within the time interval specified in the associated ACTION requirements.

Control 3.0.3 establishes the shutdown ACTION requirements that must be implemented when a Control is not met and the condition is not specifically addressed by the associated ACTION requirements. The purpose of this control is to delineate the time limits for placing the unit in a safe shutdown CONDITION when plant operation cannot be maintained within the limits for safe operation defined by the Control and its ACTION requirements. It is not intended to be used as an operational convenience which permits (routine) voluntary removal of redundant systems or components from service in lieu of other alternatives that would not result in redundant systems or components being inoperable. One hour is allowed to prepare for an orderly shutdown before initiating a change in plant operation. This time permits the operator to coordinate the reduction in electrical generation with the load dispatcher to ensure the stability and availability of the electrical grid. The time limits specified to reach lower CONDITIONS of operation permit the shutdown to proceed in a controlled and orderly manner that is well within the specified maximum cooldown rate and within the cooldown capabilities of the facility assuming only the minimum required equipment is OPERABLE. This reduces thermal stresses on components of the primary coolant system and the potential for a plant upset that could challenge safety systems under conditions for which this control applies.

If remedial measures permitting limited continued operation of the facility under the provisions of the ACTION requirement are completed, the shutdown may be terminated. The time limits of the ACTION requirements are applicable from the point in time there was a failure to meet a Control. Therefore, the shutdown may be terminated if the ACTION requirements have been met or the time limits of the ACTION requirements have not expired, thus providing an allowance for the completion of the required actions.

3/4.0 APPLICABILITY

BASES (Continued)

The time limits of Control 3.0.3 allow 37 hours for the plant to be in COLD SHUTDOWN when a shutdown is required during POWER operation. If the plant is in a lower CONDITION of operation when a shutdown is required, the time limit for reaching the next lower CONDITION of operation applies. However, if a lower CONDITION of operation is reached in less time than allowed, the total allowable time to reach COLD SHUTDOWN, or other OPERATIONAL CONDITION, is not reduced. For example, if STARTUP is reached in 2 hours, the time allowed to reach HOT SHUTDOWN is the next 11 hours because the total time to reach HOT SHUTDOWN is not reduced from the allowable limit of 13 hours. Therefore, if remedial measures are completed that would permit a return to POWER operation, a penalty is not incurred by having to reach a lower CONDITION of operation in less than the total time allowed.

The same principle applies with regard to the allowable outage time limits of the ACTION requirements, if compliance with the ACTION requirements for one control results in entry into an OPERATIONAL CONDITION or condition of operation for another control in which the requirements of the Control are not met. If the new control becomes applicable in less time than specified, the difference may be added to the allowable outage time limits of the second control. However, the allowable outage time limits of ACTION requirements for a higher CONDITION of operation may not be used to extend the allowable outage time that is applicable when a Control is not met in a lower CONDITION of operation.

The shutdown requirements of Control 3.0.3 do not apply in CONDITIONS 4 and 5, because the ACTION requirements of individual controls define the remedial measures to be taken.

Control 3.0.4 establishes limitations on a change in OPERATIONAL CONDITIONS when a Control is not met. It precludes placing the facility in a higher CONDITION of operation when the requirements for a Control are not met and continued noncompliance to these conditions would result in a shutdown to comply with the ACTION requirements if a change in CONDITIONS were permitted. The purpose of this control is to ensure that facility operation is not initiated or that higher CONDITIONS of operation are not entered when corrective action is being taken to obtain compliance with a control by restoring equipment to OPERABLE status or parameters to specified limits. Compliance with ACTION requirements that permit continued operation of the facility for an unlimited period of time provides an acceptable level of safety for continued operation without regard to the status of the plant before or after a change in OPERATIONAL CONDITION or other specified condition may be made in accordance with the provisions of the ACTION requirements. The provisions of this control should not, however, be interpreted as endorsing the failure to exercise good practice in restoring systems or components to OPERABLE status before plant startup.

3/4.0 APPLICABILITY

BASES (Continued)

When a shutdown is required to comply with ACTION requirements, the provisions of Control 3.0.4 do not apply because they would delay placing the facility in a lower CONDITION of operation.

Controls 4.0.1 through 4.0.5 establish the general requirements applicable to Surveillance Requirements. These requirements are derived from those for Surveillance Requirements stated in the Code of Federal Regulations, 10 CFR 50.36(c)(3) for plant Technical Specifications.

Control 4.0.1 establishes the requirement that surveillances must be performed during the OPERATIONAL CONDITIONS or other conditions for which the requirements of the Controls apply unless otherwise stated in an individual Surveillance Requirement. The purpose of this control is to ensure that surveillances are performed to verify the operational status of systems and components and that parameters are within specified limits to ensure safe operation of the facility when the plant is in an OPERATIONAL CONDITION or other specified condition for which the individual Controls are applicable.

Surveillance Requirements do not have to be performed when the facility is in an OPERATIONAL CONDITION for which the requirements of the associated Control do not apply unless otherwise specified. The Surveillance Requirements associated with a Special Test Exception are only applicable when the Special Test Exception is used as an allowable exception to the requirements of a control.

Control 4.0.2 establishes the limit for which the specified time interval for Surveillance Requirements may be extended. It permits an allowable extension of the specified surveillance interval to facilitate surveillance scheduling and consideration of plant operating conditions that may not be suitable for conducting the surveillance; e.g., transient conditions or other ongoing surveillance or maintenance activities. It also provides flexibility to accommodate the length of a fuel cycle for surveillances that are performed at each refueling outage and are specified with an 18 month surveillance interval.

It is not intended that this provision be used repeatedly as a convenience to extend surveillance intervals beyond that specified for surveillances that are not performed during refueling outages. The limitation of Control 4.0.2 is based on engineering judgment and the recognition that the most probable result of any particular surveillance being performed is the verification of conformance with the Surveillance Requirements. This provision is sufficient to ensure that the reliability ensured through surveillance activities is not significantly degraded beyond that obtained from the specified surveillance interval.

3/4.0 APPLICABILITY

BASES (Continued)

Control 4.0.3 establishes that the failure to perform a Surveillance Requirement within the allowed surveillance interval, defined by the provisions of Control 4.0.2, is a condition that constitutes a failure to meet the OPERABILITY requirements for a Control. Under the provisions of this control, systems and components are assumed to be OPERABLE when Surveillance Requirements have been satisfactorily performed within the specified time interval. However, nothing in this provision is to be construed as implying that systems or components are OPERABLE when they are found or known to be inoperable although still meeting the Surveillance Requirements. This control also clarifies that the ACTION requirements are applicable when Surveillance Requirements have not been completed within the allowed surveillance interval and that the time limits of the ACTION requirements apply from the point in time it is identified that a surveillance has not been performed and not at the time that the allowed surveillance interval was exceeded. Completion of the Surveillance Requirement within the allowable outage time limits of the ACTION requirements restores compliance with the requirements of Control 4.0.3. However, this does not negate the fact that the failure to have performed the surveillance within the allowed surveillance interval, defined by the provisions of Control 4.0.2., constitutes a failure to meet the OPERABILITY requirements for a Control and any reports required by 10 CFR 50.73 shall be determined based on the length of time the surveillance interval has been exceeded, and the corresponding Control ACTION time requirements, similar to those discussed in NUREG-1022, Supplement 1.

If the allowable outage time limits of the ACTION requirements are less than 24 hours or a shutdown is required to comply with ACTION requirements, e.g., Control 3.0.3, a 24-hour allowance is provided to permit a delay in implementing the ACTION requirements. This provides an adequate time limit to complete Surveillance Requirements that have not been performed. The purpose of this allowance is to permit the completion of a surveillance before a shutdown would be required to comply with ACTION requirements or before other remedial measures would be required that may preclude the completion of a surveillance. The basis for this allowance includes consideration for plant conditions, adequate planning, availability of personnel, the time required to perform the surveillance, and the safety significance of the delay in completing the required surveillance. This provision also provides a time limit for the completion of Surveillance Requirements that become applicable as a consequence of CONDITION changes imposed by ACTION requirements and for completing Surveillance Requirements that are applicable when an exception to the requirements of Control 4.0.4 is allowed. If a surveillance is not completed within the 24-hour allowance, the time limits of the ACTION requirements are applicable at that time. When a surveillance is performed within the 24-hour allowance and the Surveillance requirements are not met, the time limits of the ACTION requirements are applicable at the time that the surveillance is terminated.

INSTRUMENTATION

3/4.0 APPLICABILITY

BASES (Continued)

Surveillance Requirements do not have to be performed on inoperable equipment because the ACTION requirements define the remedial measures that apply. However, the Surveillance Requirements have to be met to demonstrate that inoperable equipment has been restored to OPERABLE status.

Control 4.0.4 establishes the requirement that all applicable surveillances must be met before entry into an OPERATIONAL CONDITION or other condition of operation specified in the Applicability statement. The purpose of this control is to ensure that system and component OPERABILITY requirements or parameter limits are met before entry into an OPERATIONAL CONDITION or other specified condition for which these systems and components ensure safe operation of the facility. This provision applies to changes in OPERATIONAL CONDITIONS or other specified conditions associated with plant shutdown as well as startup.

Under the provisions of this control, the applicable Surveillance Requirements must be performed within the specified surveillance interval to assume that the Controls are met during initial plant startup or following a plant outage.

When a shutdown is required to comply with ACTION requirements, the provisions of Control 4.0.4 do not apply because this would delay placing the facility in a lower CONDITION of operation.

RADIOACTIVE EFFLUENTS

BASES

3/4.11.3 SOLID RADIOACTIVE WASTE

This Control implements the requirements of 10 CFR Part 50.36a and General Design Criterion 60 of Appendix A to 10 CFR Part 50. The process parameters included in establishing the PROCESS CONTROL PROGRAM may include, but are not limited to waste type, waste pH, waste/liquid/solidification agent/catalyst ratios, waste oil content, waste principal chemical constituents, mixing and curing times.

ADMINISTRATIVE CONTROLS

ANNUAL RADIOACTIVE EFFLUENT RELEASE REPORT

6.9.1.7 The Annual Radioactive Effluent Release Report shall include a summary of the quantities of radioactive solid waste released from the unit as outlined in Regulatory Guide 1.21, "Measuring, Evaluating, and Reporting Radioactivity in Solid Wastes and Releases of Radioactive Materials in Liquid and Gaseous Effluents from Light-Water-Cooled Nuclear Power Plants, : Revision 1, June 1974, with data summarized on a quarterly basis following the format of Appendix B thereof. For solid wastes, the format for Table 3 in Appendix B shall be supplemented with three additional categories: class of solid wastes (as defined by 10 CFR Part 61), type of container (e.g., LSA, Type A, Type B Large Quantity) and SOLIDIFICATION agent or absorbent (e.g., cement, urea formaldehyde). This report shall also include any changes made during the reporting period to the PROCESS CONTROL PROGRAM (PCP) pursuant to PNPP Technical Specification 6.13, as well as any major changes to Solid Radwaste Treatment Systems pursuant to Control 6.15.

ADMINISTRATIVE CONTROLS

6.15 MAJOR CHANGES TO RADIOACTIVE WASTE TREATMENT SYSTEMS*

6.15.1 Licensee initiated major changes to the radioactive waste systems, liquid, gaseous and solid:

1. Shall be reported to the Commission in the Annual Radioactive Effluent Release Report for the period in which the evaluation was reviewed by the PORC. The discussion of each change shall contain:
 - a. A summary of the evaluation that led to the determination that the change could be made in accordance with 10 CFR 50.59;
 - b. Sufficient detailed information to totally support the reason for the change without benefit of additional or supplemental information;
 - c. A detailed description of the equipment, components and processes involved and the interfaces with other plant systems;
 - d. An evaluation of the change which shows the predicted releases of radioactive materials in liquid and gaseous effluents and/or quantity of solid waste that differ from those previously predicted in the license application and amendments thereto;
 - e. An evaluation of the change which shows the expected maximum exposures to MEMBERS OF THE PUBLIC in the UNRESTRICTED AREA and to the general population that differ from those previously estimated in the license application and amendments thereto;
 - f. A comparison of the predicted releases of radioactive materials, in liquid and gaseous effluents and in solid waste, to the actual releases for the period prior to when the changes are to be made;
 - g. An estimate of the exposure to plant operating personnel as a result of the change; and
 - h. Documentation of the fact that the change was reviewed and found acceptable by the PORC.
2. Shall become effective upon review and acceptance by the PORC.

*Licensee may choose to submit the information called for in this CONTROL as part of the annual USAR update.

REFERENCES

1. Title 10, "Energy", Chapter 1, Code of Federal Regulations, Parts 20, 50, 61, and 71, U.S. Government Printing Office, Washington, D.C. 20402, January 1, 1984.
2. Title 49, "Transportation", Chapter 1, Code of Federal Regulations, Parts 170-178, U.S. Government Printing Office, Washington, D.C. 20402, November 1, 1983.
3. U.S. Nuclear Regulatory Commission, "Standard Radiological Effluent Technical Specifications for Boiling Water Reactors", USNRC NUREG-0473, Revision 3, Washington, D.C. 20555, September 1982.
4. U.S. Nuclear Regulatory Commission, "Low-Level Waste Licensing Branch Technical Position on Radioactive Waste Classification," Revision 0, May 1983.
5. U.S. Nuclear Regulatory Commission, "Branch Technical Position on Waste Form", Revision 0, May 1983.
6. "Standard Test Method for Compressive Strength of Cylindrical Concrete Specimens" ASTM C39-84, American Society for Testing and Materials, Philadelphia, Pennsylvania 19103, 1984.
7. Regulatory Guide 1.8, "Personnel Selection and Training", U.S. Nuclear Regulatory Commission, Washington D.C. 20555, September, 1975.
8. "Selection and Training of Nuclear Power Plant Personnel", ANSI-N18.1-1971, American National Standards Institute, New York, New York 10018, 1971.
9. "Radman - A Computer Code to Classify and Document Packaged LLW in Accordance with 10CFR Part 61 Regulations", WMG-NP-A, Waste Management Group, Inc. Croton-on-the-Hudson, New York 10521, May 1983.
10. "Data Base Analysis Report - Perry Nuclear Power Station", Waste Management Group, Inc., Croton-on-the-Hudson, New York, New York 10521, May 1983.
11. SEG Process Control Program for Dewatering Bead or Powdered Resin with Quick Dry Dewatering System No. 2893, DW-004.
12. SEG Operating Procedure for LNPSR Radwaste Solidification System No. SS-001.
13. SEG Process Services Topical Report on Radwaste Solidification System, PS-53-0378.
14. Stock Equipment Co. Quick Dry Process for Dewatering of Bead Resin and Filter Sludge, SRS-003.

REFERENCES

15. "Perry Nuclear Power Plant Unit 1 Technical Specifications," Rev. 0, The Cleveland Electric Illuminating Company, Perry, Ohio 44081.
16. "Perry Nuclear Power Plant Units 1 and 2, Updated Safety Analysis Report", Amendment 14, The Cleveland Electric Illuminating Company, Perry, Ohio 44081.
17. Perry Nuclear Power Plant Operations Manual, "Radioactive Shipment Criteria", PAP-1304, The Cleveland Electric Illuminating Company, Perry, Ohio 44081.
18. Perry Nuclear Power Plant Operations Manual, "Shipment of Radioactive Waste For Disposal", PAP-1309, The Cleveland Electric Illuminating Company, Perry, Ohio 44081.
19. Perry Nuclear Power Plant Operations Manual, "Dry Radioactive Waste Volume Reduction Program", PAP-1901, The Cleveland Electric Illuminating Company, Perry, Ohio 44081.
20. Perry Nuclear Power Plant Operations Manual, "Plant Chemistry Control Program", PAP-1102, The Cleveland Electric Illuminating Company, Perry, Ohio 44081.
21. Perry Nuclear Power Plant Operations Manual, "10CFR61 Compliance Sampling", PAP-1102, The Cleveland Electric Illuminating Company, Perry, Ohio 44081.
22. Perry Nuclear Power Plant Operations Manual, "Miscellaneous Sampling Systems", CHI-42, The Cleveland Electric Illuminating Company, Perry, Ohio 44081.
23. Perry Nuclear Power Plant Operations Manual, "PCP Test Solidification", CHI-78, The Cleveland Electric Illuminating Company, Perry, Ohio 44081.
24. Perry Nuclear Power Plant Operations Manual, "Solid Radwaste Solidification System", RWI-G51-SRW, The Cleveland Electric Illuminating Company, Perry, Ohio 44081.
25. Perry Nuclear Power Plant Operations Manual, "Solid Radwaste Compaction System", RWI-G51-SRWC, The Cleveland Electric Illuminating Company, Perry, Ohio 44081.
26. Perry Nuclear Power Plant Operations Manual, "Process Control Program Solidification", SVI-G51-T5284, The Cleveland Electric Illuminating Company, Perry, Ohio 44081.
27. "Barnwell Waste Management Facility Site Disposal Criteria", Document S20-AD-010, Revision B, Barnwell, South Carolina 29812, January 1, 1982.

REFERENCES

28. "Radioactive Materials License WN-I-019-2", Amendments 13 and 14 U.S. Ecology, Inc., Hanford Reservation, Richland, Washington 99352, December 23, 1983.
29. "Perry Nuclear Power Plant Quality Assurance Plan", The Cleveland Electric Illuminating Company, Perry, Ohio 44081.
30. Homer, J. C. and Lutz, G. F., "Stock "Quick Dry" Vacuum Compression System for Dewatering and Volume Reduction of Filter Sludge - Summary of Test Results," Stock Equipment Company, 1986.
31. NUFAC Operating Procedure for Resin Drying (Dewatering) System, OM-43-NS.
32. Topical Report Covering Nuclear Packaging, Inc. Dewatering System, TP-02-P-A.
33. Chem-Nuclear Topical Report for Radioactive Waste Dewatering System, RDS-25506-1-A.
34. Chem-Nuclear Topical Report for Mobile Cement Solidification System, CNSI-2.
35. Setup and Operating Procedure for the RDS-1000 Unit, FO-OP-032.
36. Operating Procedure for the Mobile Cement Solidification Unit No. 221, SD-OP-050.
37. Topical Report covering Pacific Nuclear Systems Radwaste Solidification System, TP-05.
38. Operation and Maintenance Manual for the NUPAC Radwaste Solidification System, OM-114.
39. System Description of Pacific Nuclear Systems' Radioactive Waste Volume Reduction System, RVR-800.
40. Operation Procedure for RVR-800 Liquid Volume Reduction System, OM-0022-NS.

Offsite Dose Calculation Manual, ODCM