

1995 Annual Report of the AFRRI TRIGA Reactor

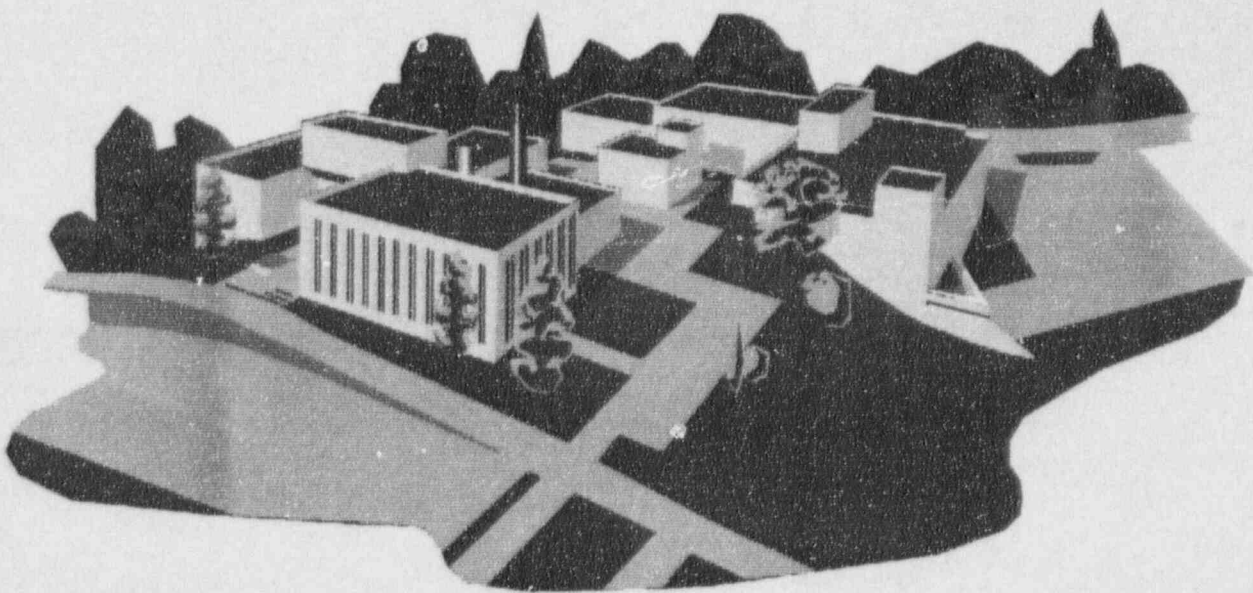

HILACOV

9605020129 960502
PDR ADOCK 05000170
R PDR

Submission of 1995 Annual Report

Submitted by

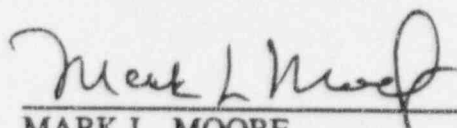

MARK L. MOORE
Reactor Facility Director

8 March 96

Date

Approved



ERIC E. KEARSLEY
Captain, MSC, USN
Director

12 March 96

Date

**Armed Forces Radiobiology Research Institute
AFRRI Triga Reactor Facility**

1 January, 1995 - 31 December, 1995

To satisfy the requirements of:
U.S. Nuclear Regulatory Commission, License No. K-84 (Docket No. 50-170),
Technical Specification 6.6.1.b.

The Reactor Facility Director would like to acknowledge the participation of the following
AFRRI personnel for their contributions to this annual report.

Edited by:

Mr. Robert George, Reactor Operations Supervisor

With Contributions From:

LTC Leonard Alt, Senior Staff Engineer
Mr. Guy Bateman, Scientific Medical Illustrator
SFC Danny McClung, Senior Reactor Operator Candidate
Mr. Steve Miller, Deputy Reactor Facility Director
Mr. Joh. Nguyen, Senior Reactor Operator
Mr. Tom O'Brien, Radiation Safety Officer

Submitted By:

Mark Moore
Reactor Facility Director

Armed Forces Radiobiology Research Institute
8901 Wisconsin Ave.
Bethesda Md. 20889-5603
Telephone: (301) 295-1290
Fax: (301) 295-0735

**1995 ANNUAL REPORT
OF THE
AFRRI TRIGA REACTOR**



Docket 50-170

License R-84

**Submitted By
Mark Moore
Reactor Facility Director**

1995 ANNUAL REPORT

TABLE OF CONTENTS

Introduction

General Information

Section I

Changes to the facility design, performance characteristics and operational procedures, results of surveillance tests and inspections

Section II

Energy generated by current reactor core and number of pulses \$2.00 or larger

Section III

Unscheduled shutdowns

Section IV

Safety-related corrective maintenance

Section V

Facility changes and changes to procedures as described in the Safety Analysis Report. New experiments or tests during the year

Section VI

Summary of radioactive effluent released

Section VII

Environmental radiological surveys

Section VIII

Exposures greater than 10% of 10 CFR 20 limits

Attachment A

Revised Reactor Administrative and Operational Procedures

Attachment B

10 CFR 50.59 safety evaluations of modifications, changes, and enhancements to procedures or facilities

Attachment C

Appointment letters for various Reactor and Radiation Facility Safety Committee changes

Attachment D

Summary of all Maintenance for 1995

Attachment E
Fresh Water Use In Pump House

INTRODUCTION

1995 ANNUAL REPORT

INTRODUCTION

In 1995 the AFRRRI reactor facility was available for irradiation services throughout the year with only the annual reactor maintenance shutdown causing any substantial non-operational period. Members of the reactor staff were heavily involved in a DNA Dispersion project at White Sands, New Mexico. This project utilized the reactor for multiple irradiations throughout the year.

The microprocessor-based instrumentation and control console, fully installed in 1990 after a two year test period, completed its fifth year of successful operation as the primary control and safety instrumentation. The console operated throughout the year with only minimal malfunctions (Section IV). There was only one unplanned shutdown during 1995, which is detailed in Section III.

The Deputy Secretary of Defense made a decision to close the Armed Forces Radiobiology Research Institute and to begin decommissioning the reactor in FY97. The reactor staff began several weeks determining methods to decommission the reactor and cost factors involved, as well as cost factors to keep the reactor open. All data was submitted to the institute director in an attempt to provide additional information affecting the decision to close AFRRRI or its reactor. As of December 31, no change to the decision had been made.

The annual reactor facility audit was held on 25 and 26 October 1995. The auditors concluded that the reactor was being operated in a safe manner in conformance with the Technical Specifications and Operating License. No violations were observed during this inspection. Discussion of the inspection is covered in Section 1. E. The auditors did note that the morale of the staff was much higher than they would expect in the wake of the decision to close AFRRRI. The Nuclear Regulatory Commission did not inspect the AFRRRI TRIGA Reactor during 1995, nor was this required.

The reactor core remained unchanged except for the movement of a fuel element from grid position E13 to D13 to allow for the placement of the Core Experiment Tube (CET) in a different location in the core. The CET was moved from F13 position near a control rod, to E13 which is equal distance from, and further from, two control rods. This change did not effect the performance of the core.

Reactor staff changes included the departures of SGM Harry Spence, SFC Mike Laughery, and Capt Daniel Robbins. Added to the staff was Capt Oscar Lessard. Capt Lessard has begun his operator training along with SFC Brian Cohill. SFC Danny McClung and ENS John Ventura were examined and licensed by the NRC as Senior Reactor Operators.

Director CAPT Robert L. Bumgarner departed AFRRRI in January and was replaced by CAPT Eric E. Kearsley, as Acting Director, until he was appointed Director permanently in February.

Changes were made to the procedures and facilities during 1995. These changes were supported by an extensive safety review process in accordance with the provisions of 10 CFR 50.59. These various changes will be discussed fully in Sections I & V.

The reactor staff provided personnel to assist in conducting operational and safety inspections of the Fast Burst Reactor facilities at Aberdeen Proving Ground, Maryland, and White Sands Missile Range, New Mexico. At the request of Cornell University, an operations audit of their reactor facility was conducted.

In August a lock on a pump house door was found to be broken allowing access to a fresh water supply by a group of construction contractors. The lock was immediately replaced and the workers were instructed that they would have to obtain water from some other source. For further information on this issue see Attachment E, "Fresh Water Use In Pump house".

The remainder of this report is written in a format designed to include information items required by the AFRRRI TRIGA Reactor Technical Specifications. Items not specifically required are presented in the General Information section. Following sections correspond to the required items as listed in Section 6.6.1.b of the AFRRRI TRIGA Reactor Technical Specifications.

GENERAL INFORMATION

Key Personnel

Reactor and Radiation Facility Safety Committee

GENERAL INFORMATION

All personnel held their positions as listed throughout the entire year unless otherwise specified.

1. Current key AFRRI administration personnel (as of 31 Dec 95) are as follows:
Director - CAPT Eric E. Kearsley, USN (Effective 17 Feb 1995)
Chairman, Radiation Sciences Department - CAPT C. B. Galley, USN
AFRRI Radiation Protection Officer - Mr. Thomas J. O'Brien
2. Reactor Senior Technical Manager:
Reactor Facility Director - Mr. Mark Moore (SRO)
3. Current key Reactor Operations Personnel:
Deputy Reactor Facility Director - Mr. Stephen Miller (SRO)
Reactor Operations Supervisor - Mr. Robert George (SRO)
Training Coordinator - Mr. Stephen Miller (SRO)
Maintenance - Mr. John Nguyen (SRO)
Administration - SFC Danny McClung (SRO)
Senior Staff Engineer - LTC Leonard A. Alt (SRO)
4. Other Senior Reactor Operators: ENS John C. Ventura (SRO)
5. Operator Candidates: SFC Brian Cohill (Effective 28 Dec 94)
Capt Oscar Lessard (Effective 5 June 95)
6. Newly Licensed Operators: SFC Danny K. McClung (SRO)(Effective 23 May 95)
ENS John C. Ventura (SRO)(Effective 23 May 95)
7. Additions to staff during 1995: Capt Oscar Lessard (Effective 5 June 95)
8. Departures during 1995: SGM Harry Spence (20 Jan 1995)
SFC Mike Laughery (23 Jan 1995)
Capt Daniel Robbins (20 Jan 1995)

9. There was several staff changes to the Reactor and Radiation Facility Safety Committee during 1995. COL David G. Jarrett replaced Col John R. Sheehan as the chairman of the committee. Mr. Mark A. Miller of the Naval Research Laboratories replaced Mr. Kirk King. Dr. Leslie McKinney replaced LTC Eric Daxon as a non-voting special member and SFC Danny McClung replaced Capt Daniel Robbins as the recorder. The appointment letters are shown at Attachment C.

The 1995 RRFSC consisted of the following membership in accordance with AFRI Reactor Technical Specifications (as of 31 Dec 95):

Regular Members:

Mr. Thomas O'Brien (AFRI Radiation Protection Officer)
Mr. Mark Moore (Reactor Facility Director, AFRI)
Mr. Marcus Voth (Director, Breazeale Reactor, Pennsylvania State University)(Reactor Operations Specialist)
Mr. Mark A. Miller (Radiation Safety Officer, Naval Research Laboratory)

Chairman:

COL David G. Jarrett (Director's Representative)

Special Members:

CAPT Charles B. Galley, USN (Chairman, Radiation Sciences Dept., AFRI)
(Certified HP)

Non-voting members:

Mr. James Caldwell (Office of Environmental Protection, Montgomery County, MD)
Dr. Leslie McKinney (Radiation Pathophysiology and Toxicology Department,
AFRI)

Non-Voting Recorder:

SFC Danny K. McClung

As required by the reactor Technical Specifications, four meetings of the RRFSC were held:

| | |
|------------------|------------------------|
| 1 March 1995 | Full committee meeting |
| 2 June 1995 | Full committee meeting |
| 18 October 1995 | Subcommittee meeting |
| 18 December 1995 | Subcommittee meeting |

SECTION I

**Changes to the Facility Design,
Performance Characteristics
and Operational Procedures.
Results of Surveillance Tests
and Inspections.**

SECTION 1

A summary of changes to the facility design, performance characteristics, operational procedures, and results from surveillance testing are contained in this section. The revised reactor administrative and operational procedures can be found at Attachment A, while the 10 CFR 50.59 reviews can be found at Attachment B for all of the following changes.

A. DESIGN CHANGES:

1. The Continuous Air Monitor (CAM) electronics were replaced in all five of the reactor CAM's. The new electronics package replaces the older outdated shelf of electronics. The unit was calibrated to respond to a radiation source with the same output reading as the previous electronics unit. The performance characteristics of the unit did not change.
2. The reactor security system interface was upgraded with a new and more user friendly computer interface. The upgrade involved replacing the computer terminal at which designated staff members interface with the D600 unit. The D600 unit, which controls and monitors the security system, was not changed or replaced. The functionality of the security system remained the same, only the operator interface to the system changed.
3. The Safety and Health Department changed the supplier for the 16 in-plant perimeter TLDs located on the AFRRI roof or at ground level near AFRRI. The new dosimeters from Naval Dosimetry use the same TLD-100 chip to detect radiation as did the Eberline Inc. dosimeters which have been used since approximately 1980.
4. A remote switch was installed in room 3106A to open the reactor ventilation dampers. The purpose of this switch is to allow security guards to open the reactor dampers after they have called a reactor staff member for authorization to do so. Guards have been instructed not to operate the switch unless directly authorized by a reactor staff member. The switch is located behind a locked door so that access to the switch will not be inadvertent. Summer thunderstorms often disrupt building electrical power long enough to allow damper system relays to trip, thus causing the dampers to automatically close. This switch, which is wired in parallel to the control room switch, allows guards to reset the dampers for non problem trips and identifies if the trip is a non problem trip or if an actual problem exists. If an actual emergency condition exists, pressing this new switch will not cause the dampers to open and therefore will not proliferate the consequences of an actual event.
5. The sample port tubes in the reactor stack were replaced for the stack gas monitoring system. The old tubes were damaged during maintenance and were replaced.
6. The Stack Gas Monitor (SGM) printer was removed from the SGM unit and replaced by a remote chart recorder in the control room. The printer was used by the SGM computerized electronics to print an average Argon-41 concentration every six hours but because Argon releases are calculated by hand, the printouts from the SGM were never

used for effluent release calculations.. The chart recorder in the control room will allow operators to view any unusual trends in the output of the SGM. This change does not decrease the effectiveness of the SGM.

7. A 50.59 review was completed for the replacement of the Stack Gas Monitor (SGM) digital electronics shelf with an analog based set of electronics. The new electronics package will have outputs for alarms, lights, and remote meters or recorders. These outputs will provide the same function as the old unit. The new electronics module replaces the old unit with newer, more reliable electronics. As of the 31 December 1995, the new electronics had not arrived. They are expected to arrive early in 1996.

B. PERFORMANCE CHARACTERISTICS:

No changes to the core occurred during 1995 which would affect performance. The performance characteristics of the core did not change.

C. ADMINISTRATIVE PROCEDURES:

1. HPP 7-3, "Airborne Radioactivity Samplers and Monitors", Table 4.a.(1), was updated to indicate which of the CAM chart recorders would normally be running, or turned off. Several of the non reactor CAMs do not require chart recorder operation to perform their intended function.
2. Procedure A3, "Facility Modification" was changed on page 2, Paragraph 3 to indicate that a change to the SAR would be made followed by a review by the RRFSC for changes that have no unreviewed safety issues. Previously the procedure required that all changes to the SAR be reviewed by the RRFSC before the change could be implemented.

D. OPERATIONAL PROCEDURES:

1. A change to Procedure 8, TAB A, Logbook Entry Checklist, added a section on malfunction log entries. The new section specifies key words to be used for formatting malfunction entries. This change will help ensure that entries are made in a more consistent manner and that all information necessary for the entry is recorded.
2. In Procedure 1, TAB A, "Reactor Exposure Room Entry", and in HPP 3.1, "Reactor Irradiation Facilities", the limit for the Exposure Room Continuous Air Monitor readings for non monitored openings was changed from 200 cpm above background to 2000 cpm inclusive of background. The purpose of this change was to eliminate interpretation of the procedure when performing non monitored openings.

3. Procedure 11, "Air Particulate Monitor (CAM) Procedure" was changed on two different occasions during 1995 to reflect the change for the daily tests of the new CAM electronics. The procedure was also changed to eliminate the use of the secondary CAM chart recorder unless the primary CAM is bypassed for maintenance or malfunctions. Both CAMs will retain the capability to close the dampers in the event of an emergency.
4. Procedure A2, "Personnel Passage Through the Prep Area" was changed to add a specific section on prep area frisking policy/procedure. The section specifies that a person will frisk if they have been in the yellow painted area, been in an exposure room, handled potentially contaminated material, or at the request of reactor or SHD personnel.
5. The Startup, Shutdown, and Safety Checklists were all changed to place a "*" at the end of each line on which a numeric entry is required. This will prompt operators to place numbers and not check marks on lines with limits indicated. Previously, either check marks or numbers were accepted.

E. RESULTS OF SURVEILLANCE TESTS AND INSPECTIONS:

Two items in TRIGA TRACKER were not complete by the end of the year. Both items were briefings and are scheduled for February 1996. A list of completed tasks is in Attachment D.

Malfunctions discovered are detailed in section IV.

There was only one audit during 1995. The audit was conducted by Mr. Thomas Wright from the U. S. Department of Energy and Mr. Lewis Hulman of Parallax Inc. Mr. Wright was formerly a Senior Reactor Operator at the AFRRRI facility and is currently involved in safety activities with the Department of Energy. Mr. Hulman has previous experience on a USNRC Nuclear Power Reactor Inspection Team. No safety concerns or violations were found by the auditors.

SECTION II

Energy Generated by Current

Reactor Core and Number of Pulses

\$2.00 or Larger.

SECTION II

Energy generated by the reactor core:

| Month | Kw-Hrs |
|-------|--------------|
| JAN | 258.2 |
| FEB | 2711.0 |
| MAR | 1177.8 |
| APR | 943.2 |
| MAY | 1579.3 |
| JUN | 674.9 |
| JUL | 3952.8 |
| AUG | 2524.7 |
| SEP | 571.0 |
| OCT | 3019.6 |
| NOV | 417.0 |
| DEC | <u>485.2</u> |
| TOTAL | 18314.7 |

| | |
|---|------------------|
| Total energy generated this year: | 18,314.7 Kw-hrs |
| Total energy on fuel elements: | 873,719.4 Kw-hrs |
| Total energy on FFCRs: | 140,921.3 Kw-hrs |
| Total pulses this year \geq \$2.00: | 0 |
| Total pulses on fuel element \geq \$2.00: | 4159 |
| Total pulses on FFCRs \geq \$2.00: | 47 |
| Total pulses this year: | 176 |
| Total pulses on fuel elements: | 10837 |
| Total pulses on FFCRs: | 1072 |

SECTION III

Unscheduled Shutdowns

SECTION III

Unscheduled Shutdowns:

There was one unscheduled shutdown during 1995. Power to the Control System Console (CSC) was lost when an Uninterruptible Power Supply (UPS) shut off power to the console. This power loss was caused by one battery cell shorting out in one of the four 12 volt batteries internal to the UPS unit. The UPS electronics, detecting the low battery voltage, performed their intended function by shutting off the output power from the UPS to the CSC. The reactor scrambled during a low power operation when power to the CSC was lost. See the malfunction listing in section IV.

SECTION IV

Safety-Related Corrective Maintenance

SECTION IV

Safety-Related Corrective Maintenance.

The following are excerpts from the malfunction logbook during the reporting period. The reason for the corrective action taken, in all cases, was to return the failed equipment to its proper operational status.

- 17 Mar 95 During the daily startup checklist, a zero power pulse was fired and the console resumed operation without collecting any data or indicating that a pulse was fired. The console was shutdown and rebooted. The console was tested by firing several more zero power pulses with each of the zero power pulses successfully collecting data. The console was determined to be fully operational and the startup resumed.
- 05 May 95 The auxiliary damper closed lamp at the guard desk indicated that the dampers had closed. An inspection of the dampers proved that they were indeed open and that the indicator lamp at the guard desk was incorrect. The damper closure system was tested to verify operability of the damper closure system. The problem was determined to be the switch which controls the damper lamp was out of adjustment. The switch was adjusted, tested, and the system was found to be fully operational.
- 07 Jun 95 The Stack Gas Monitor (SGM) was found to be indicating zero counts during the daily startup checklist. Reactor operations were suspended. The problem was determined to be a bad contact between the power supply and the main CPU board. The board contacts were cleaned and the board was reseated in the SGM unit. The unit was electronically and isotopically recalibrated before reactor operations resumed.
- 11 Jun 95 A suspected storm related power problem (lightning) caused two unrelated problems to reactor systems. A reactor staff member was called in after a nighttime thunderstorm for an air damper closed problem. The operator reset the dampers and the dampers closed a few seconds later. Each attempt to open the dampers resulted in the dampers closing a few seconds later. Diagnosis of the problem revealed a problem with an air flow switch in an exhaust leg of the ventilation system. The switch was repaired and the damper system was tested. The damper system remained open after the repair and closed when called for as intended by the CAM damper closure system. The closure system was determined to be fully operational and capable of performing its intended function.

The second problem was a message on the Control System Console (CSC) that the console network looks dead. Diagnosis of the problem proved that one of the

two network boards between the Control System Console (CSC) and Data Acquisition and Control (DAC) unit had failed. Both network boards were replaced thus allowing the resumed communications between the CSC and DAC. The console booted up normally. The network was tested, found to be fully operational, and a full daily startup proved all other systems were functioning properly.

13 Jun 95 The Stack Gas Monitor (SGM) was indicating zero counts during the daily startup checklist. The problem was diagnosed as a power failure to the SGM which caused the system to lose the system settings. The unit was reinitialized and the set points were reset. The SGM was source tested and found to be fully operational.

14 Jun 95 The Stack Gas Monitor was found to be non operational during the daily startup checklist. The historical record in the computerized unit showed a power loss to the unit the previous evening. Testing revealed a problem with the uninterruptible power supply (UPS) into which the SGM was plugged, the SGM was plugged into an alternate UPS. The alternate UPS, which was being used to operate a PC type computer, was determined to be capable of operating both units. A new UPS was ordered for the SGM.

When the SGM again went down the staff suspected that the power problem (suspected lightning strike) from 11 June had made it through the UPS circuitry and into the SGM circuitry. The staff replaced the SGM power supply, high voltage and single channel analyzer card, printer card, printer, and NaI detector. The CPU card was not changed. The new components were electronically calibrated, and after an isotopic calibration by Safety and Health Department personnel, the unit was tested, found to be fully operational, and brought back on line.

15 Jun 95 Operators discovered that the security system monitor was blank. The procurement office was notified of the situation and the procurement representative called the security company (DEI) for a replacement monitor. The repair or replacement of the monitor was under contract with DEI. Until DEI could arrive with a replacement monitor, a spare VGA computer monitor was plugged into the security system computer. The temporary monitor provided the same picture as the DEI monitor: which was also a VGA computer monitor.

03 Jul 95 The SGM was found to be indicating no counts during the daily startup checklist. The problem was determined to be that the SGM had lost all its set points in the computerized CPU card. The set points were reentered and the SGM was source tested and found to be fully operational. Reactor staff researched and ultimately placed an order for a replacement set of electronics for the SGM. The new electronics will have the same sensitivity, high and low alarms, and outputs for remote meters and chart recorders.

- 12 Sep 95 Excessive air was found to be leaking around the lower O-ring seal in the transient rod drive. The drive was initially replaced with a spare drive but a problem with the drive mechanism resulted in cannibalizing the O-ring from the replacement drive and using it to repair the original drive. The original drive was reinstalled and all functions of the drive were tested. The reactor was brought back on line.
- 13 Nov 95 The transient rod drive did not give a green (air applied) indication on the CSC high resolution monitor when air was applied to the drive. The problem was discovered to be a crushed rubber dirt boot located inside the transient rod drive anvil. The boot was preventing the anvil from compressing when air was applied to the drive. The anvil was repaired by obtaining an identical rubber boot and shock absorber from a spare drive anvil and replacing the unit in the original anvil. The unit was tested by applying air to the drive and seeing that the anvil compressed enough to allow the air applied indication was displayed on the CSC high resolution monitor. All transient rod drive functions were tested and the reactor was returned to service.
- 21 Nov 95 Both lamps (high and fail alarm) on the SGM remote meter came on and could not be reset. The problem was determined to be a lamp located inside the meter had burnt out. The internal lamp is used to provide light for two photosensitive transistors for the alarm points. When the lamp burned out the photo transistors could no longer detect the light thus causing both alarm points to trip. The meter was disassembled and the lamp was replaced. The alarm points were tested on the meter, found to be fully operational, and the alarm points were reset.
- 03 Dec 95 During a low power operation the reactor console lost power and the reactor scrambled. This power loss was caused by one battery cell shorting out in one of the four 12 volt batteries internal to the UPS unit and the UPS electronics, detecting the low battery voltage, shutting off the output power from the UPS to the CSC. The UPS is suspected to have changed from line power to backup power due to noise, power sag or some other power anomaly, and when the UPS could not maintain the output with the lower battery voltage, the UPS performed its intended function and shut off the output power. The console was plugged into another UPS which was operating a PC type computer. The replacement UPS power rating was checked to verify that there would be no overloading problems using it to operate the console electronics. The console was rebooted and tested with the daily startup checkouts before normal operations resumed.
- 08 Dec '95 The SGM was giving a high reading with the source in the detector chamber. The high voltage and single channel analyzer card was replaced and the unit was recalibrated. The Safety and Health Department performed an isotopic calibration of the unit before the unit was brought back on line. The replacement electronics for the SGM are expected to arrive in early 1996.

SECTION V

**Facility Changes and Changes to
Procedures as Described in the
Safety Analysis Report. New
Experiments or Tests During the Year.**

SECTION V

Changes to the facility and procedures as described in the Safety Analysis Report (SAR) and new experiments or tests performed during the year are contained in this section.

- A. The SGM printer was removed from the unit and replaced by a remote chart recorder in the control room. The SAR was changed to eliminate any references to the SGM printer or printouts and the continuous chart recorder was added to provide a continuous record of effluent counts. The chart recorder provides to the operator a chart showing any unusual trends in the output of the SGM.
- B. A 50.59 review was completed for the replacement of the Stack Gas Monitor (SGM) digital electronics shelf with an analog based set of electronics. The replacement will change several sections of the SAR and modify several procedures. As of 31 December 1995, the new electronics had not arrived and no changes had been made to either the SAR or procedures. The electronics are expected to arrive early in 1996 and the SAR and procedural changes will be made upon installation of the electronics.
- C. There were no new experiments or tests performed during the reporting period.

Attachment B contains the safety evaluations made for changes not submitted to the NRC pursuant to the provisions of 10 CFR 50.59. Each modification was described and qualified using Administrative Procedure A3, Facility Modification. This procedure utilizes a step-by-step process to document that there were no unreviewed safety questions and no changes required to the Technical Specifications.

SECTIONS VI through VIII

Summary of Radioactive Effluent Released.

Summary of Radiological Surveys.

Exposures Greater Than 10% of 10 CFR Limits

SECTION VI

Summary of Radioactive Effluent Released:

- A. Liquid Waste: The reactor produced no liquid waste during 1995.
- B. Gaseous Waste: There were no particulate discharges in 1995.

The total activity of Ar-41 discharged in 1995 was 7.9 Curies. The estimated average activity release was less than 1% of the permitted effluent concentration for unrestricted areas (Table 2 of Appendix B to 10 CFR 20).

| | | |
|------------|----------------|--------|
| Quarterly: | Jan - Mar 1995 | 1.8 Ci |
| | Apr - Jun 1995 | 1.3 Ci |
| | Jul - Sep 1995 | 2.6 Ci |
| | Oct - Dec 1995 | 2.2 Ci |

- C. Solid Waste: All solid radioactive waste material was transferred to the AFRRRI byproduct license; none was disposed of under the R-84 License.

SECTION VII

Environmental Radiological Surveys:

- A. Environmental sampling of soil and vegetation reported radionuclide levels that were not above the normal range. The radionuclides that were detected were those normally expected from natural background and from long-term fallout.
- B. The environmental monitoring (TLD) program reported the following results at a 95% confidence level for 1995:
 - 1. The annual average reading of approximately 20 thermoluminescent dosimeters (TLD) background stations, located 2 miles or greater from the AFRRRI site, was determined to be 22.0 ± 1.8 millirem.
 - 2. The annual average reading of approximately 30 environmental TLD stations located on the NNMC grounds was determined to be 20.5 ± 1.6 millirem
- C. The reactor in-plant surveys, specified in HPP 3-2, did not exceed any of the action levels specified in HPP 0-2.

SECTION VIII

Exposures Greater than 10% of 10 CFR 20 Limits:

There were no doses to reactor staff personnel or reactor visitors greater than 10% of 10 CFR 20 occupational and public radiation dose limits, respectively.

ATTACHMENT A

Revised Reactor Administrative and Operational Procedures

Procedure A2, Personnel Passage Through The Prep Area

Procedure A3, Facility Modification

Procedure 1 Tab A, Reactor Exposure Room Entry

Procedure 8 Tab A, Logbook Entry Checklist

Procedure 8 Tab B, Daily Operational Startup Checklist

Procedure 8 Tab B1, Daily Safety Checklist

Procedure 8 Tab I, Daily Operational Shutdown Checklist

Procedure 11, Air Particulate Monitor (CAM) Procedure

PERSONNEL PASSAGE THROUGH THE PREP AREA

GENERAL

Access to the Reactor Prep Area is limited to personnel who are granted access in accordance with the reactor physical security plan and Operational Procedure 1. The Reactor Facility Director is responsible for maintaining an unescorted access roster for the Reactor Prep Area and for providing a Prep Area briefing to all persons listed on that roster. This administrative procedure does not recapitulate the operational procedure. Rather, it presents specific guidelines for Reactor Prep Area passage, and frisking for individuals who are authorized access.

SPECIFIC

1. ROUTINE PASSAGE: (EXPOSURE ROOM DOORS CLOSED)
 - a. Personnel who are authorized unescorted access to the Reactor Prep Area may pass through the Prep Area as necessary.
 - b. Personnel who are being escorted through the Reactor Prep Area may pass through the Prep Area only with their escort.
 - c. Only appropriate personal dosimetry that has been issued by SHD or AFRRRI Security is required for routine passage through the Reactor Prep Area. There is no requirement to wear a pocket chamber in addition to the AFRRRI issued TLD for routine passage.
2. CONTROLLED PASSAGE: (EXPOSURE ROOM DOOR OPEN)
 - a. Only personnel associated with the experiment/operation being performed are normally authorized access to the Reactor Prep Area during an exposure room opening. These personnel will be required to wear the AFRRRI TLD dosimeter (issued with their AFRRRI badge), pocket chamber (if dose rate at face of door is 2 mrem/hr or more), and AFRRRI wrist dosimeter or finger ring dosimeter if they enter the exposure room.

All personnel who enter an exposure room will log their pocket chamber reading in the pocket chamber log prior to entering the room for the first time that day and will enter the final pocket chamber reading following their exit from the exposure room at the end of the day. Each individual who enters an exposure room is responsible for monitoring his accumulated dose throughout the day to ensure the he/she does not exceed the AFRRRI daily

d. Upon request of reactor staff or SHD personnel.

The frisking procedure is posted at both exits from the Prep Area near the survey instruments.

FACILITY MODIFICATION

GENERAL

Changes to the Reactor Facility and operational procedures must comply with requirements specified in the Reactor License, and 10 CFR 50.59. It is required that modifications to the facility or procedures as described in the Safety Analysis Report (SAR) be documented with a written safety analysis. Under 10 CFR 50.59, a licensee may make changes to the facility provided there are no changes made to the Technical Specifications, there are no unreviewed safety questions, and that a proper safety analysis is carried out, documented, and reviewed.

Applicability:

- The Facility Modification Procedure applies to proposed facility changes or changes in the operating procedures.
- The referenced procedure will not cover routine replacement of parts or components with equivalent parts or components.

DESCRIPTION

This administrative procedure consists of these instructions, the Facility Modification Worksheet Guide, and two worksheets to facilitate a 10 CFR 50.59 review of modifications and to determine if a detailed safety analysis is necessary. The instructions in the Facility Modification Worksheet Guide are used to determine which worksheet must be completed for the modification. One of three conclusions regarding the proposed facility modification will be reached:

1. The modification requires prior approval or a license amendment from the USNRC,
2. The modification may be made according to the provisions of 10 CFR 50.59(a)(1) (Facility Modification Worksheet # 1), or
3. The modification does not require a 10 CFR 50.59 safety analysis (Facility Modification Worksheet # 2).

PERSONNEL PASSAGE THROUGH THE PREP AREA

GENERAL

Access to the Reactor Prep Area is limited to personnel who are granted access in accordance with the reactor physical security plan and Operational Procedure 1. The Reactor Facility Director is responsible for maintaining an unescorted access roster for the Reactor Prep Area and for providing a Prep Area briefing to all persons listed on that roster. This administrative procedure does not recapitulate the operational procedure. Rather, it presents specific guidelines for Reactor Prep Area passage, and frisking for individuals who are authorized access.

SPECIFIC

1. ROUTINE PASSAGE: (EXPOSURE ROOM DOORS CLOSED)
 - a. Personnel who are authorized unescorted access to the Reactor Prep Area may pass through the Prep Area as necessary.
 - b. Personnel who are being escorted through the Reactor Prep Area may pass through the Prep Area only with their escort.
 - c. Only appropriate personal dosimetry that has been issued by SHD or AFRRRI Security is required for routine passage through the Reactor Prep Area. There is no requirement to wear a pocket chamber in addition to the AFRRRI issued TLD for routine passage.
2. CONTROLLED PASSAGE: (EXPOSURE ROOM DOOR OPEN)
 - a. Only personnel associated with the experiment/operation being performed are normally authorized access to the Reactor Prep Area during an exposure room opening. These personnel will be required to wear the AFRRRI TLD dosimeter (issued with their AFRRRI badge), pocket chamber (if dose rate at face of door is 2 mrem/hr or more), and AFRRRI wrist dosimeter or finger ring dosimeter if they enter the exposure room.

All personnel who enter an exposure room will log their pocket chamber reading in the pocket chamber log prior to entering the room for the first time that day and will enter the final pocket chamber reading following their exit from the exposure room at the end of the day. Each individual who enters an exposure room is responsible for monitoring his accumulated dose throughout the day to ensure the he/she does not exceed the AFRRRI daily

exposure limits of 50 mrem/day or 100 mrem/week. Extremity dosimetry is required only if work is to be performed on an experimental array or within 1 meter of the core projection.

- b. Personnel authorized unescorted access to the Reactor Prep Area or personnel being escorted through the Reactor Prep Area may pass through the Prep Area when an exposure room is open with permission from the reactor staff person in charge during the opening if the following guidelines are met:

The person desiring passage must stop just inside the Prep Area door upon seeing that an exposure room door is open and request permission from the reactor staff member in charge before proceeding. At that time, the reactor staff and safety staff members monitoring the exposure room opening will determine if the radiation level at the outside entrance to the exposure room in direct line of sight with the core projection is less than or equal to 2 mrem/hr. If this reading is less than or equal to 2 mrem/hr, the reactor staff member may grant passage permission. There is no requirement to wear a pocket chamber in addition to the AFRRRI issued TLD for control passage. If the reading is greater than 2 mrem/hr, passage will be denied.

3. OPEN PASSAGE: (NON-ROUTINE)

The Prep Area may be opened for passage by personnel traveling between buildings at AFRRRI when maintenance is being performed on the normal connecting hallway. This is not a routine occurrence and warrants written approval from the Reactor Facility Director with concurrence from the Chairman, Safety and Health Department. In addition, the Prep Area must be monitored at all times by appropriately trained personnel. Prior to the opening of the Reactor Prep Area for open passage, the Safety and Health Department shall conduct a radiological survey of the area and certify that no radiation areas exist within the Prep Area and that the non-painted areas of the Prep Area floor are free of contamination. There is no requirement for personnel who pass through the Prep Area to wear pocket chambers or frisk themselves during periods of open passage. Open passage will be suspended during exposure room openings.

4. FRISKING

Frisking upon exit from the Prep Area is only required for the following conditions:

- a. Personnel who have entered the yellow painted work zone area.
- b. Personnel who have been in either exposure room.
- c. Personnel who may have handled potentially contaminated material.

d. Upon request of reactor staff or SHD personnel.

The frisking procedure is posted at both exits from the Prep Area near the survey instruments.

FACILITY MODIFICATION

GENERAL

Changes to the Reactor Facility and operational procedures must comply with requirements specified in the Reactor License, and 10 CFR 50.59. It is required that modifications to the facility or procedures as described in the Safety Analysis Report (SAR) be documented with a written safety analysis. Under 10 CFR 50.59, a licensee may make changes to the facility provided there are no changes made to the Technical Specifications, there are no unreviewed safety questions, and that a proper safety analysis is carried out, documented, and reviewed.

Applicability:

- The Facility Modification Procedure applies to proposed facility changes or changes in the operating procedures.
- The referenced procedure will not cover routine replacement of parts or components with equivalent parts or components.

DESCRIPTION

This administrative procedure consists of these instructions, the Facility Modification Worksheet Guide, and two worksheets to facilitate a 10 CFR 50.59 review of modifications and to determine if a detailed safety analysis is necessary. The instructions in the Facility Modification Worksheet Guide are used to determine which worksheet must be completed for the modification. One of three conclusions regarding the proposed facility modification will be reached:

1. The modification requires prior approval or a license amendment from the USNRC,
2. The modification may be made according to the provisions of 10 CFR 50.59(a)(1) (Facility Modification Worksheet # 1), or
3. The modification does not require a 10 CFR 50.59 safety analysis (Facility Modification Worksheet # 2).

Facility Modification Worksheet Guide

1. **Technical Specification Change:** If the proposed modification requires a change in the Technical Specifications, a license amendment is required prior to making the change. NRC approval is required; do not implement the change without this approval.
2. **Unreviewed Safety Question:** If an unreviewed safety question is created by the proposed change as defined in 10 CFR 50.59(a)(2) such that the change increases the probability of occurrence or severity of an accident described in the SAR, can malfunction in a manner that can cause an accident of a different type than described in the SAR or can decrease safety margins as defined in Technical Specifications, then NRC approval is required. Do not implement the change without this approval.
3. If the proposed modification makes a change in the facility as described in the SAR or changes a procedure as described in the SAR, the change can be performed under a 10 CFR 50.59 analysis with a safety review, if there are no unreviewed safety issues (10 CFR 50.59(a)(2)). The change may be made followed by a review by the RRFSC. Go to Facility Modification Worksheet # 1.
4. If the proposed modification does not make a change to the facility as described in the SAR or to a procedure as described in the SAR and does not pose an unreviewed safety issue, a 10 CFR 50.59 analysis is not required. Go to Facility Modification Worksheet # 2.

Facility Modification Worksheet 1

10 CFR 50.59 Analysis

Proposed Change _____

Submitted by: _____ Date _____

1. Description of change:

2. Reason for change:

3. Verify that the proposed change does not involve a change to the Technical Specifications or produce an unresolved safety issue as specified in 10 CFR 50.59(a)(2). Attach an analysis to show this.

Analysis attached? Yes _____

4. The proposed modification constitutes a changes in the facility or an operational procedure as described in the SAR. Describe which (check all that apply).

Procedure _____ Facility _____ Experiment _____

Facility Modification Worksheet 1

5. Specify what sections of the SAR are applicable. In general terms describe the necessary updates to the SAR. Note that this description need not contain the final SAR wording.

6. For facility modifications, specify what testing is to be performed to assure that the systems involved operate in accordance with their design intent.

Facility Modification Worksheet 1

7. Specify associated information.

New drawings are: Attached
Not required

Does a drawing need to be sent to Logistics? Yes No
Are training materials effected? Yes No
Will any Logs have to be changed? Yes No
Are other procedures effected? Yes No

List of items affected:

8. Create an Action Sheet containing a list of associated work specified in item # 7, attach a copy, and submit another to the RFD (modification of drawings must be approved by the RFD).

Action Sheet: Submitted Not Required

Reviewed and approved by RFD _____ Date _____

RRFSC Concurrence _____ Date _____

Facility Modification Worksheet 2

No 10 CFR 50.59 Analysis Required

Proposed Change _____

Modification to: Procedure _____ Facility _____ Experiment _____

Submitted by: _____ Date _____

1. Description of change:

2. Verify that the proposed change does not involve a change to the Technical Specifications, the facility as described in the SAR, or procedures as described in the SAR, and does not produce an unresolved safety question as defined in 10 CFR 50.59(a)(2).

3. If change involves a facility modification, attach a drawing if appropriate. If structural facility drawings need updating, modification of drawings must be approved by RFD and forward a copy of changes necessary to Logistics.

4. Determine what other procedures, logs, or training material may be affected and record below.

5. List of associated drawings, procedures, logs, or other materials to be changed:

6. Create an Action Sheet containing the list of associated work specified above, attach a copy, and submit it to the RFD.

Action Sheet: Submitted _____ Not Required _____

Reviewed and approved by RFD _____ Date _____

RRFSC Notified _____ Date _____

REACTOR EXPOSURE ROOM ENTRY

1. REFERENCES

- a. 10 CFR 20, "Standards for Protection Against Radiation"
- b. USNRC licenses: R-84, 19-08330-02
- c. AFRI Instruction 6055.8
- d. AFRI Health Physics Procedure 3-1

2. GENERAL

a. **PURPOSE:** This procedure specifies all safety and security procedures for activities involving entry into the AFRI TRIGA Reactor exposure rooms, currently designated exposure rooms 1 and 2 (rooms 1123 and 1122).

b. **AUTHORIZED ENTRY:** Both AFRI picture badge and U-badge personnel, may enter a reactor exposure room under the supervision of the Reactor Facility Director (RFD) or his representative. Visiting personnel (V badge) require special authorization by both the Chairman, Safety and Health Department (SHD) and RFD to enter either exposure room. In general, permission to enter the exposure rooms will be granted personnel whose duties require such entry; however, permission may be denied to personnel for serious or repeated safety or security violations, or for safety reasons emanating from conditions in the exposure rooms. All personnel who are granted unescorted access to the prep area or warm storage will receive a special prep area safety briefing prior to being granted access. Only personnel who have been granted permanent unescorted access will be given card access to the prep area. The RFD is responsible for maintaining a roster in the prep area for personnel who have been granted permanent unescorted access. Other personnel requiring unescorted access to the prep area or warm storage for a specific purpose or time period may be granted special access in writing by the RFD with concurrence of SHD. However, these personnel who are granted special access from the RFD will not be given card access to the prep area.

- c. **ER ENTRY INSTRUCTIONS** - All personnel will:

- (1) Know the Reactor staff representative is in charge of all operations in the prep area. Obtain permission to enter either exposure room from the Reactor staff representative.
- (2) Wear AFRRI TLD whole body badge and pocket dosimeter.
- (3) Wear wrist or finger dosimeter if work is to be performed on an experimental array or within one meter of the core projection.
- (4) Wear booties, eye protection, gloves and coat.
- (5) Check and log pocket dosimeter reading on log in prep area prior to entry.
- (6) Familiarize themselves with approximate radiation levels in the room, based on radiological surveys performed and data obtained by SHD.
- (7) Ensure that all materials removed from the exposure room are properly labeled and entered on the exposure room entry log (AFRRI FORM 130) and the activated materials control log.
- (8) Glove and lab coat requirements may be waived by the SHD monitor or reactor representative on an individual basis for personnel who will not be touching anything in the exposure room. There must be a specific reason for waiving such requirements.

d. DEPARTURE FROM REACTOR EXPOSURE ROOM ENTRY

PROCEDURES: Any departure from the following procedures will require a special work permit (SWP). Exceeding any radiation dose limits will require a written justification from the supervisor of the research project which must be approved by the Head, SHD.

3. SHD EXPOSURE ROOM SURVEY

a. EXPOSURE ROOM CAM:

- (1) Prior to opening either exposure room, the respective CAM must read 2000 cpm or less. If the CAM reads 2000 cpm or greater, change the filter on the CAM and put it in the radioactive materials bag in the CAM drawer. If 10 minutes or more have elapsed since the end of the reactor run, the door may be opened to the first step to facilitate radioeffluent clearance in the room. Then check the CAM after 1 minute and, if the reading has not increased by more than 100 cpm, proceed with the exposure room opening. If it has increased by more than 100 cpm, change the filter and wait two more minutes and repeat as necessary. If the CAM alarms during or immediately after a run, change the filter and reset the CAM.
- (2) If either exposure room CAM or the Prep Area CAM is found malfunctioning or inoperable, notify the Reactor Representative or

Reactor Operations Supervisor (ROS) and Radiation Safety Officer (RSO) immediately. No opening shall be initiated if the exposure room to be opened does not have an operable CAM.

b. DOSE RATE AT FACE OF DOOR: If the dose rate at the face of the plug door in the direct line of sight of the reactor tank bulge reads greater than 100 mrem/hr, the door will be closed sufficiently to preclude access. The plug door will be reopened upon agreement of the SHD and RFD representatives for reevaluation of radiation levels. When the dose rate at the face of the door is below 100 mrem/hr, the opening procedure may continue.

c. DOSE LEVELS IN ROOM: Exposure rates will be measured at specific sites in the rooms. These measurements will be given to both the reactor representative and the personnel entering the room. Additionally the readings will be entered in the room entrance log (AFRRI FORM 130) and kept in the prep area. The levels will be measured at:

- (1) The reactor door face in the direct line of sight of the reactor tank bulge
- (2) At the contamination line in the entrance of the room
- (3) The middle of the room
- (4) 30 cm from the tank wall or shield
- (5) Contact with the tank wall or shield
- (6) The area(s) where individual(s) will be working for an extended period of time and any other place deemed necessary by the reactor representative.

d. ROUTINE ENTRY: Entry is routinely permitted only when the maximum reading in any occupiable area is 1 rem/h or less. Entry may be permitted if levels are 1-5 rem/h, but no work will be permitted in fields over 1 rem/h. If personnel are working in a specific area for an extended period of time, the dose rate in that area will be measured.

- (1) Readings over 100 mrem/hr (closed window) will be specifically identified. All dose rate readings will be reported to the Reactor representative and entry personnel. When appropriate, after consultation with the SHD and Reactor representatives, stay times will be assigned for entry personnel. AFRRI limits of 100 mrem/week and 50 mrem/day are to be used as the basis of stay time determinations.
- (2) All exposure room entries will be checked by the SHD monitor for compliance with radiation safety aspects of applicable Reactor Use Requests (RURs). If not, non-compliance will be reported to the RFD and to SHD.

e. FILLING OUT THE SURVEY OF EXPOSURE ROOM OPENING LOG:
The exposure room opening log sheet must be filled out completely for each opening of an exposure room. Care must be taken to fill out each blank on the entry log sheet. If a section is not applicable to the particular opening, N/A should be filled in the blank.

4. NON-MONITORED OPENING:

a. Personnel may enter the exposure rooms without a SHD monitor present if ALL the following conditions hold:

- (1) The reactor has not been to power in that ER since the last survey.
- (2) Survey meter readings at the door indicate safe entry conditions (should be less than 1 mrem/hr).
- (3) The ER CAM should be observed, and its reading (net) should be less than 200 cpm above background.
- (4) The last survey indicates that the maximum dose rate in any area where work is to be performed did not exceed 100 mrem/hr.

b. An entry will be made in the exposure room log by a reactor staff member, with a note that the survey has been waived.

c. SHD must be notified if any radioactive materials or equipment are to be removed from the prep area.

5. PERSONNEL PROTECTION PROCEDURES

a. Dosimetry and protective clothing requirements are given in paragraph 2.c, ER Entry Instructions.

b. Entry is permitted only after the SHD monitor has completed the survey and reported results to those about to enter (excluding non-monitored openings - reference Paragraph 4, above).

c. All personnel shall record initial dosimeter reading in the prep area dosimeter log prior to entering the exposure room for the first time each day. Personnel shall read dosimeters when leaving the exposure room and record a final dosimeter reading in the prep area log at completion of daily operations. Net doses over 10 mrem must be reported to the SHD Monitor.

d. Protective clothing will be removed in such a way as not to contaminate "clean" areas by items from "dirty" areas.

e. All personnel will "frisk" themselves before leaving the prep area.

6. SPECIFIC ACTIONS TO OPEN EXPOSURE ROOM DOORS

- a. Turn up exposure room lights (this can be waived for experiment needs).
- b. Check plug door tracks for obstructions; ensure all obstacles are clear of the door (including ropes).
- c. Ensure that only authorized personnel (see 2.b.) are present in the reactor prep area during exposure room openings.
- d. When facility safety interlocks and opening procedures have been satisfied, insert key into exposure room door key panel and open door. **DO NOT LEAVE KEY IN LOCK UNATTENDED.**
- e. Open door in accordance with entry procedures. Ensure all required data is logged in entry log.
- f. Ensure that individuals who will be moving lead, bismuth, or other heavy materials are wearing steel-toed shoes.
- g. Limit exposure times of all personnel entering the exposure rooms based on the results of the radiation survey.

7. ACTIVATED MATERIALS

a. **PLACING MATERIAL IN EXPOSURE ROOM:** Before placing any equipment or material in an exposure room for irradiation the following will be observed:

- (1) Equipment tagged as AFRRI property: a memo must be sent to both the RFD and the AFRRI property officer. The memo must state that the equipment is knowingly being irradiated and therefore request that it be removed from the property books. It must also state that should the material remain byproduct material after a reasonable amount of time it will be disposed of as radioactive waste. The memo must contain all nomenclature as well as an adequate description of the equipment in order for it to be identified on the property book.
- (2) Non-tagged AFRRI equipment or material (to be returned): a memo or statement on the reactor RUR must be sent to the RFD giving the kinds and amounts of byproduct material expected to be produced (that is the material that the experimenter wishes to be returned) and a copy or number of their radionuclide authorization number. The memo or RUR statement must be specific and contain an accurate description of the material being exposed (converted to byproduct). Other information will be required from personnel before any material is allowed to be removed

from the prep or warm storage areas (see next section of this procedure 7.b. and 7.c.)

- (3) Non-tagged equipment or material (not to be returned): A memo or statement on the RUR that the experimenter understands that byproduct material produced as a result of their irradiations will be disposed of as radioactive waste, and additionally any material not specifically requested to be held, will be disposed of as radioactive waste in the next shipment.
- (4) Non-AFRRI owned equipment/material: A signed memorandum from the responsible property owner that they understand that byproduct materials generated in excess of their license will be disposed of as radioactive waste unless prior arrangements have been made with the reactor/SHD staffs for storage. Any material not removed within a reasonable amount of time will automatically be disposed of as radioactive waste.

b. SURVEY OF MATERIALS COMING OUT OF EXPOSURE ROOM

- (1) All material leaving the exposure rooms must be surveyed for activation or contamination. Survey meter readings will be used to determine dose levels. Smear surveys may be used, if the SHD representative deems them necessary. All materials will be labeled appropriately in accordance with HPP 0-2 and HPP 3-1.
- (2) All special equipment that has been activated such as chambers, rotators, motors, meters, etc., will be stored under the control of the reactor license or the AFRRI byproduct license in warm storage or the prep area. Removal of items from the prep area will only be allowed in accordance with HPP 3-1.

c. DISPOSITION OF ACTIVATED MATERIALS

All activated or contaminated materials will be under the control of the reactor license while such materials remain in the reactor controlled area. Removal of any radioactive materials from the reactor controlled area will be done in accordance with HPP 3-1.

8. COMPLETION OF ENTRY

a. The Reactor Staff Representative will check to see that all personnel have left the exposure room before the plug door is closed. In the event that the warning horn in either exposure room is disconnected, for testing or experiment requirements, the exposure room plug door shall not be closed until at least two (2) licensed reactor operators visually inspect the room to ensure that no personnel remain in the room. To ensure compliance with the reactor Technical Specifications, the names of these licensed operators present at the exposure room

closing shall be entered into the reactor operations logbook and on AFRI FORM 130. At the completion of the test or experiment, the warning horn shall be reconnected and tested. All actions regarding the warning horn shall be entered in GREEN ink in the reactor operations logbook.

b. The SHD monitor will not leave the area while the plug door is open without notifying the Reactor Staff Representative.

c. Lock the exposure room door control panel; reset lights, if appropriate.

d. Resecure the prep area on departure.

LOGBOOK ENTRY CHECKLIST

I. Operational Logbook

1. The reactor operations logbook is a before-the-fact record, that is, entries will be logged before the operator actually performs the planned function. Any late entries will be so noted.
2. The operations logbook will have a hardbound cover and will be sequentially numbered by volume. The pages will be dated at the top of each page and each page will be sequentially numbered.
3. The Reactor Facility Director (RFD) will review each logbook upon its completion; he will make an appropriate entry in the back of the logbook and sign the entry. The operator who makes the final entry at the end of a logbook is responsible for ensuring that the ROS is notified that the logbook is ready for RFD review.
4. All items in GREEN (see below) that are not closed out during the working day will be carried in GREEN at the end of the day and again at the beginning of the next operational day.
5. The entries will be made in ink and in accordance with the following designated color code:
 - a. **BLACK and BLUE-BLACK:**
 - (1) Console locked and unlocked. The individual at the console will enter his/her name and the supervisory licensed operator's name, if necessary.
 - (2) Checklist number and completion time.
 - (3) Power level at criticality and subsequent power level changes.
 - (4) Reactor SCRAM.
 - (5) Mode of operations. Use appropriate stamp or entry to designate the operation:
 - (a) Steady State
 - (b) Square Wave
 - (c) Pulse

(6) Operation of reactor associated facilities such as lead shield doors, pneumatic tube systems, etc., unless such operations cause a change of reactivity (see 5.b.(2) below).

(7) Change of personnel at the console. Name of personnel will be entered along with the licensed operator present in the control room, if the person at the console is not a licensed operator.

(8) The operator in charge will be designated in the logbook whenever multiple operators are signed on the console.

(9) Completion of the daily startup and shutdown checklists and weekly checklist.

(10) Signature of reactor operator to close out the log for the day.

(11) Designation of the SRO on-call and physicist in charge (PIC).

(12) Reactor calibrations and data.

(13) All changes to logbook entries (including line outs, error corrections, changes to operations mode stamp lines, and end-of-page line outs) will be initialed or signed by the operator.

b. RED:

(1) K-excess measurements, to include experiment worth determinations.

(2) Actions which affect reactivity:

(a) Core movement.

(b) Fuel movement.

(c) Control rod physical removal for maintenance.

(d) Experiment loading and removal from the CET, PTS, pool, or core.

c. GREEN:

(1) Any reactor malfunctions noted upon discovery/occurrence with a second entry noting corrective action has been completed.

(2) Additional items entered at the discretion of the operator such as addition of make-up water to the reactor pool, etc.

(3) Any Technical Specification required equipment taken out of service for any reason. A second entry is made when the unit is returned to service.

6. When an operation requiring entry into the logbook falls under more than one color code, the color to be used will be determined via the following order of precedence: RED - GREEN - BLACK/BLUE-BLACK.

II. Malfunction Logbook

All entries in the malfunction logbook should include the following information. For consistency, the bold italic words should be copied into the malfunction log prior to the information.

DATE, TIME, SIGNATURE OF PERSON DISCOVERING MALFUNCTION

SYMPTOM: of problem

This section describes how the system is acting or malfunctioning, i.e., channel went full scale, pump failed, keyboard stopped responding to keystrokes etc.

IMMEDIATE ACTION TAKEN

This section is for denoting such things as Reactor Secured, SHD notified.

RFD NOTIFIED:

A remark should be made that the RFD or acting RFD was notified.

DIAGNOSIS : of problem

A narrative description of what was discovered to be causing the problem, i.e., Which system was malfunctioning or which component failed.

SOLUTION: / repair

A narrative description of what was done to correct the problem. This could include both physical changes or administrative changes, i.e., a component was replaced and the unit was recalibrated, an additional backup system installed, an administrative prohibition on ... was initiated.

OPERATIONAL VERIFICATION AND/OR CALIBRATION:

A description of what actions were taken to verify that the new unit/repair would indeed perform the function for which it was intended, i.e., a calibration signal, system actuated multiple times, system tested, system calibrated with a source. Indicate whether the change will require staff training.

SIGNATURE RFD

DAILY OPERATIONAL STARTUP CHECKLIST

Checklist number _____
Time completed _____

Date _____
Supervised by _____
Assisted by _____

I. EQUIPMENT ROOM (Room 3152)

- 1. Air compressor pressure (80 - 110 psig) *
2. Water drained from air compressor
3. Air dryer operating
4. Doors 231,231A, and roof hatch SECURED

II. LOBBY AREA

Lobby audio alarm turned off

III. EQUIPMENT ROOM (Room 2158)

- 1. Prefilter differential pressure (< 8 psid) *
2. Primary discharge pressure (15 - 25 psig) *
3. Demineralizer flow rates set to 6 gpm (5.5 -6.5 gpm) *
4. Stack roughing filter (notify supervisor if > 1.0" of water) *
5. Stack absolute filter (notify supervisor if > 1.35" of water) *
6. Visual inspection of area
7. Door 2158 SECURED

IV. PREPARATION AREA

Visual inspection of area

V. REACTOR ROOM (Room 3161)

- 1. Transient rod air pressure (78 - 82 psig) *
2. Shield door bearing air pressure (8.5 - 9.5 psig) *
3. Visual inspection of core and tank
4. Number of fuel elements and Fuel elements *
control rods in tank storage Control rods *
5. Air particulate monitor (CAM)
(a) Primary operating and tracing
(b) Backup operating
(c) Channel test completed, damper closure verified
6. Stack gas monitor quality assurance checked
7. Door 3162 SECURED

* Numerical Entry

VI. REACTOR CONTROL ROOM (Room 3160)

| | | | |
|-----|--|---------------------------|---------------|
| 1. | Emergency air dampers reset | | |
| 2. | Console recorders dated | | |
| 3. | Stack flow and fuel temperature recorders dated | | |
| 4. | Logbook dated and reviewed | | |
| 5. | Water monitor box | | |
| | (a) Background activity (10 - 60 cpm) | | * |
| | (b) Water monitor box resistivity (> 0.2 Mohm-cm) | | * |
| | (c) DM1 resistivity (> 0.5 Mohm-cm) | | * |
| | (d) DM2 resistivity (> 0.5 Mohm-cm) | | * |
| 6. | Stack gas flow rate (15 - 35 Kcfm) | | * |
| 7. | Stack linear flow rate (1.0 - 2.0 Kft/min) | | * |
| 8. | Gas stack monitor | | |
| | (a) Background (2 - 20 cpm) | | * |
| | (b) Alarm check | | |
| | (c) High alarm set to 3.2E-5 microCi/cc at stack top | | |
| 9. | Radiation monitors | | |
| | Monitor | Alarm Point | Reading |
| | | Functional | (mrem/hr) |
| | (a) R-1 | _____ | (<20) _____ * |
| | (b) R-2 | _____ | (<10) _____ * |
| | (c) R-3 | _____ | (<10) _____ * |
| | (d) R-5 | _____ | (<20) _____ * |
| | (e) E-3 | _____ | (<10) _____ * |
| | (f) E-6 | _____ | (<10) _____ * |
| | | | Alarm Setting |
| | | | (mrem/hr) |
| | | | _____ 500 |
| | | | _____ 10 |
| | | | _____ 10 |
| | | | _____ 100 |
| | | | _____ 10 |
| | | | _____ 10 |
| 10. | TV monitors on | | |
| 11. | CAM high level audible alarm check | | |
| 12. | Water temperature (inlet) (5 - 35 °C) | | * |
| 13. | Water level log completed | | |
| 14. | Console lamp test completed | | |
| 15. | Time delay operative | | |
| 16. | Source level power greater/equal to 0.5 cps. | | |
| 17. | Prestart operability checks performed | | |
| 18. | Interlock Tests | | |
| | a) Rod raising, SS mode _____ | (e) 1 kW/Pulse mode _____ | |
| | (b) Rod raising, Pulse mode _____ | (f) NM-1000 HV _____ | |
| | (c) Source RWP _____ | (g) Inlet Temp _____ | |
| | (d) Period RWP _____ | | |
| 19. | SCRAM checks (at least one per rod) | | |
| | (a) % Power 1 _____ | (h) Reactor key _____ | |
| | (b) % Power 2 _____ | (i) Manual _____ | |
| | (c) Fuel temp 1 _____ | (j) Emergency Stop _____ | |
| | (d) Fuel temp 2 _____ | (k) Timer _____ | |
| | (e) HV loss 1 _____ | (l) CSC Watchdog _____ | |
| | (f) HV loss 2 _____ | (m) DAC Watchdog _____ | |
| | (g) Pool level _____ | | |
| 20. | Zero power pulse | | |

DAILY SAFETY CHECKLIST

Checklist number _____
Time completed _____

Date _____
Supervised by _____
Assisted by _____

I. EQUIPMENT ROOM (Room 3152)

- 1. Air compressor pressure (80 - 110 psig) *
2. Water drained from air compressor
3. Air dryer operating
4. Doors 231,231A, and roof hatch SECURED

II. EQUIPMENT ROOM (Room 2158)

- 1. Prefilter differential pressure (< 8 psid) *
2. Primary discharge pressure (15 - 25 psig) *
3. Demineralizer flow rates set to 6 gpm (5.5 - 6.5 gpm) *
4. Stack roughing filter (notify supervisor if > 1.0" of water) *
5. Stack absolute filter (notify supervisor if > 1.35" of water) *
6. Visual inspection of area
7. Door 2158 SECURED

III. PREPARATION AREA

Visual inspection of area

IV. REACTOR ROOM (Room 3161)

- 1. Transient rod air pressure (78 - 82 psig) *
2. Shield door bearing air pressure (8.5 - 9.5 psig) *
3. Visual inspection of core and tank
4. Number of fuel elements and Fuel elements *
control rods in tank storage Control rods *
5. Air particulate monitor (CAM)
(a) Primary operating and tracing
(b) Backup operating
(c) Channel test completed, damper closure verified
6. Stack gas monitor quality assurance checked
7. Door 3162 SECURED

* Numerical Entry

V. LOBBY AREA

Lobby audio alarm turned off _____

VI. REACTOR CONTROL ROOM (Room 3160)

1. Emergency air dampers reset _____
2. Console recorders dated _____
3. Stack flow and fuel temperature recorders dated _____
4. Logbook dated and reviewed _____
5. Water monitor box
 - (a) Background activity (10 - 60 cpm) _____ *
 - (b) Water monitor box resistivity [> 0.2 Mohm-cm] _____ *
 - (c) DM1 resistivity (> 0.5 Mohm-cm) _____ *
 - (d) DM2 resistivity (> 0.5 Mohm-cm) _____ *
6. Stack gas flow rate (15 - 35 Kcfm) _____ *
7. Stack linear flow rate (1.0 - 2.0 Kft/min) _____ *
8. Gas stack monitor
 - (a) Background (2 - 20 cpm) _____ *
 - (b) Alarm check _____
 - (c) High alarm set to 3.2E-5 microCi/cc at stack top _____
9. Radiation monitors

| Monitor | Alarm Point Functional | Reading (mrem/hr) | Alarm Setting (mrem/hr) |
|---------|---------------------------|----------------------|----------------------------|
| (a) R-1 | _____ | (<20) _____ * | _____ 20 |
| (b) R-2 | _____ | (<10) _____ * | _____ 10 |
| (c) R-3 | _____ | (<10) _____ * | _____ 10 |
| (d) R-5 | _____ | (<20) _____ * | _____ 20 |
| (e) E-3 | _____ | (<10) _____ * | _____ 10 |
| (f) E-6 | _____ | (<10) _____ * | _____ 10 |
10. TV monitors on _____
11. CAM high level audible alarm check _____
12. Water temperature (inlet) (5 -35 °C) _____ *
13. Water level log completed _____
14. Source level power greater/equal to 0.5 cps. _____

DAILY OPERATIONAL SHUTDOWN CHECKLIST

Checklist No. _____
 Time Completed _____

Date _____
 Supervised by _____
 Assisted by _____

I. REACTOR ROOM (Room 3161)

- 1. All rod drives DOWN _____
- 2. Carriage lights OFF _____
- 3. Door 3162 SECURED _____
- 4. Channel test completed on both CAMs _____
- 5. Door 3161 locked with key _____

II. EQUIPMENT ROOM (Room 3152)

- 1. Distillation unit discharge valve CLOSED _____
- 2. Air dryer OPERATIONAL _____
- 3. Doors 231, 231A, and roof hatch SECURED _____

III. EQUIPMENT ROOM (Room 2158)

- 1. Primary discharge pressure (15 - 25 psig) *
- 2. Demineralizer flow rates set to (5.5 - 6.5 gpm) *
- 3. Visual inspection for leaks _____
- 4. Door 2158 and 2164 SECURED _____

IV. PREPARATION AREA

- 1. ER 2 plug door CONTROL LOCKED _____
 Door closed; and handwheel PADLOCKED _____
- 2. ER 2 lights ON and rheostat at 10% _____
- 3. ER 1 plug door CONTROL LOCKED _____
 Door closed; and handwheel PADLOCKED _____
- 4. ER 1 lights ON and rheostat at 10% _____
- 5. Visual inspection of area _____
- 6. Warm storage doors closed _____

V. LOBBY ALARM

| | |
|----------------------------|-------|
| Lobby alarm audio ON | _____ |
|----------------------------|-------|

VI. REACTOR CONTROL ROOM (Room 3160)

| | |
|--|-------|
| 1. Reactor tank lights OFF | _____ |
| 2. Console chart recorder pens raised | _____ |
| 3. Steady-state timer OFF | _____ |
| 4. Console LOCKED, and all required keys returned to lock box | _____ |
| 5. Diffuser pumps OFF | _____ |
| 6. Purification, secondary and primary pumps ON | _____ |
| 7. Reactor monthly usage summary completed | _____ |
| 8. Radiation monitors | _____ |

| MONITOR | READING | HIGH LEVEL ALARM SETTING (mrem/hr) |
|---------|----------------|---------------------------------------|
| a. R-1 | (<20) _____ * | 20 _____ |
| b. R-2 | (< 10) _____ * | 10 _____ |
| c. R-3 | (<10) _____ * | 10 _____ |
| d. R-5 | (<20) _____ * | 20 _____ |
| e. E-3 | (<10) _____ * | 10 _____ |
| f. E-6 | (<10) _____ * | 10 _____ |
| g. R-6 | (<10) _____ * | 10 _____ |

* Numerical Entry

AIR PARTICULATE MONITOR(CAM) PROCEDURE

GENERAL

This procedure specifies how to test the CAM to ensure proper operation of this monitoring device. A channel test will be performed on both reactor room CAMs at the beginning and end of each day.

SPECIFIC

1. OPERATING and TRACING

Check that the primary CAM is operating and tracing with the correct time indicated on the chart and check that the secondary CAM is operating. Ensure the flow rate is >6 cfm and not off scale.

2. CHANNEL TEST WITH SOURCE

- a. Place the switch on the front of the CAM to "test" and verify a reading of 1000 cpm $\pm 20\%$. Reset the switch.
- b. Open shield door and change the detector filter if the filter appears excessively dirty or the flow rate has dropped below 6 cfm (with the door closed). Place the used filter in the radioactive waste box in each CAM drawer.
- c. Slowly bring a radioactive source near the detector. Observe the meter on the front of the CAM. The yellow light will activate at approximately 4,000 counts per minute. The red light will activate at approximately 10,000 counts per minute; the alarm will sound and the dampers will close. Reset the alarm, close the chamber door and return the source to the CAM drawer.
- d. Annotate completion of the channel test on chart paper with initials, time, and date performed for primary CAM. Annotate completion of the channel test on secondary CAM chart paper only when primary CAM is bypassed.

3. TEST FREQUENCY

This entire procedure will be performed in conjunction with the daily startup or safety checklist. Items 1, 2a and 2d will be performed again as part of the daily shutdown checklist.

4. BY-PASS of PRIMARY CAM

When the primary CAM is by-passed, the secondary CAM chart recorder needs to be activated, then perform items 1, 2a, and 2d.

ATTACHMENT B

10 CFR 50.59 Safety Evaluations of Modifications, Changes, and Enhancements to Procedures or Facilities

Replacement Of CAM Electronics

Replacement Of Reactor Security Computer

Substitution Of In-Plant Perimeter Monitoring TLDs

Section On Malfunction Log Entries Added To Procedure 8, Tab A

HPP 3-1 Changed For CAM Level Reading For Exposure Room Entry

HPP 7-3 Changed To Add Chart Recorder Settings

Section Added To Prep Area Frisking Procedure

Procedure 11 Changed To Reflect Change Of CAM Chart Recorder Usage

Damper Reset Switch Added To Reactor Foyer

Procedure 1, Tab A, CAM Level Reading for Exposure Room Entry Changed

Stack Gas Monitor Stack Sample Tubes Replaced

Remove Stack Gas Monitor Printer

Replace Stack Gas Monitor Electronics

Revision Of Daily Operational Startup Checklist

Revision Of Daily Operational Shutdown Checklist

Revision Of Daily Safety Checklist

Revise Air Particulate Monitor (CAM) Procedure

Revise Facility Modification Procedure

FACILITY MODIFICATION SUMMARY SHEET
1995

| NUM | INITIAL DATE | TYPE CHANGE | LOCATION | PROPOSED CHANGE | WS # | COMPLETED DATE | APPROVED DATE (RFD) | APPROVED DATE (RRFSC) |
|-----|--------------|-------------|-----------------|--|------|----------------|---------------------|-----------------------|
| 1 | 3 Jan 95 | Facility | P11 | Replacement of CAM Electronics | 2 | 3 Aug 95 | 4 Jan 95 | 1 Mar 95 |
| 2 | 3 Jan 95 | Facility | PSP | Replacement of Reactor Security Computer | 2 | 4 Jan 95 | 4 Jan 95 | 1 Mar 95 |
| 3 | 9 Feb 95 | Facility | HPP 4-6c | Substitution of Navy TLDs for in-plant perimeter monitoring | 2 | 9 Feb 95 | 9 Feb 95 | 1 Mar 95 |
| 4 | 23 Feb 95 | Procedure | P8-Tab A | Add Section on Malfunction Log Entries to Procedure 8, Tab A | 2 | 1 Mar 95 | 23 Feb 95 | 1 Mar 95 |
| 5 | 12 May 95 | Procedure | HPP 3-1 | Change CAM level reading for exposure room entry | 2 | 31 Oct 95 | 1 Jun 95 | 18 Oct 95 |
| 6 | 15 Feb 95 | Procedure | HPP 7-3 | Change to add chart recorder settings | 2 | 31 Oct 95 | 1 Jun 95 | 2 Jun 95 |
| 7 | 25 May 95 | Procedure | PROC. A2 | Add section on Prep Area frisking | 2 | 18 Jul 95 | 2 Jun 95 | 2 Jun 95 |
| 8 | 25 May 95 | Procedure | PROC. 11 | Change use of secondary CAM chart recorder | 2 | 2 Jun 95 | 1 Jun 95 | 2 Jun 95 |
| 9 | 25 May 95 | Facility | n/a | Damper reset switch added to reactor foyer. | 2 | 25 May 95 | 25 May 95 | 2 Jun 95 |
| 10 | 25 May 95 | Procedure | PROC. 1, Tab A | Change CAM level reading for exposure room entry | 2 | 24 Jan 96 | 1 Jun 95 | 18 Oct 95 |
| 11 | 25 May 95 | Facility | n/a | Replace tubes from stack monitoring system | 2 | 25 May 95 | 25 May 95 | 2 Jun 95 |
| 12 | 20 Jun 95 | Facility | SAR | Remove stack gas monitor printer | 1 | | 21 Jun 95 | 18 Oct 95 |
| 13 | 12 Jul 95 | Facility | SAR | Replace stack gas monitor electronics | 1 | | 12 Jul 95 | 18 Oct 95 |
| 14 | 14 Jul 95 | Procedure | PROC. 8, Tab B | Revision of Daily Operational Startup Checklist | 2 | 14 Jul 95 | 14 Jul 95 | 18 Oct 95 |
| 15 | 14 Jul 95 | Procedure | PROC. 8, Tab I | Revision of Daily Operational Shutdown Checklist | 2 | 14 Jul 95 | 14 Jul 95 | 18 Oct 95 |
| 16 | 14 Jul 95 | Procedure | PROC. 8, Tab B1 | Revision of Daily Safety Checklist | 2 | 14 Jul 95 | 14 Jul 95 | 18 Oct 95 |
| 17 | 8 Aug 95 | Procedure | Proc. 11 | Revise Air Particulate Monitor (CAM) Procedure | 2 | 9 Aug 95 | 9 Aug 95 | 18 Oct 95 |
| 18 | 9 Aug 95 | Procedure | Proc. A3 | Revise Facility Modification Procedure | 2 | 9 Aug 95 | 9 Aug 95 | 18 Oct 95 |

Facility Modification Worksheet 2

No 10 CFR 50.59 Analysis Required

Replacement of the CAM Electronics

Proposed Change _____

Modification to: Procedure _____ Facility XXX Experiment _____
Submitted by: George Date 03 Jan 1995

1. Description of change:

Replacement of the CAM electronics module. The old electronics have become outdated and the electronics are being replaced as part of preventive maintenance. The new electronics module is a one for one replacement.

2. Verify that the proposed change does not involve a change to the Technical Specifications, the facility as described in the SAR, or procedures as described in the SAR, and does not produce an unresolved safety question as defined in 10 CFR 50.59(a)(2). NONE. One for one replacement

3. If change involves a facility modification, attach a drawing if appropriate. If structural facility drawings need updating, forward a copy of changes necessary to Logistics. NONE.

4. Determine what other procedures, logs, or training material may be affected and record below. NONE.

5. List of associated drawings, procedures, logs, or other materials to be changed:
Updated drawings will be filed.
Change Procedure 11 after installation is completed.

6. Create an Action Sheet containing the list of associated work specified above, attach a copy, and submit it to the RFD.

Action Sheet: Submitted _____ Not Required XXX

Reviewed and approved by RFD [Signature] Date 04 JAN 1995

RRFSC Notified [Signature] Date 01 MAR 1995

Facility Modification Worksheet 2

No 10 CFR 50.59 Analysis Required
Replacement of the Reactor Security Computer

Proposed Change _____

Modification to: Procedure _____ Facility XXX Experiment _____
Submitted by: George Date 03 Jan 1995

1. Description of change:

The reactor security computer system is being upgraded with a new and more user friendly computer interface. The new system is designed as a one for one replacement. The new computer will allow the operator to control alarm points, schedules, badges, and it will deliver alarm messages to the security desk in AFRRI. The D600 unit which is the microprocessor controller specified in the reactor physical security plan will not change. The new computer interface will communicate with the D600 unit.

2. Verify that the proposed change does not involve a change to the Technical Specifications, the facility as described in the SAR, or procedures as described in the SAR, and does not produce an unresolved safety question as defined in 10 CFR 50.59(a)(2). NONE.

3. If change involves a facility modification, attach a drawing if appropriate. If structural facility drawings need updating, forward a copy of changes necessary to Logistics. NONE. Same as before

4. Determine what other procedures, logs, or training material may be affected and record below. Security guards were trained to clear alarms. Further training for reactor staff to be scheduled.

5. List of associated drawings, procedures, logs, or other materials to be changed:

NONE

6. Create an Action Sheet containing the list of associated work specified above, attach a copy, and submit it to the RFD.

Action Sheet: Submitted _____ Not Required XXX

Reviewed and approved by RFD [Signature] Date 04 JAN 1995

RRFSC Notified [Signature] Date 01 MAR 1995

Facility Modification Worksheet 2

No 10 CFR 50.59 Analysis Required

Proposed Change _____

Modification to: Procedure _____ Facility X Experiment _____

Submitted by: Tom O'Brien Date 23 Jan 95

1. Description of change:

Substitute Naval Dosimetry Supplied Dosimeters for the Eberline, Inc dosimeters used for the 16 inplant perimeter TLDs (not environmental) located on AFKRI roof or at ground level near AFKRI. Both dosimeters are equally capable as they both use TLD-100 to detect radiation.

2. Verify that the proposed change does not involve a change to the Technical Specifications, the facility as described in the SAR, or procedures as described in the SAR, and does not produce an unresolved safety question as defined in 10 CFR 50.59(a)(2). Verified

3. If change involves a facility modification, attach a drawing if appropriate. If structural facility drawings need updating, modification of drawings must be approved by RFD and forward a copy of changes necessary to Logistics. N/A

4. Determine what other procedures, logs, or training material may be affected and record below. None for RSDR. Minor revision to STD HPP 4-6.C. (see attached)

5. List of associated drawings, procedures, logs, or other materials to be changed:
None

6. Create an Action Sheet containing the list of associated work specified above, attach a copy, and submit it to the RFD.

Action Sheet: Submitted _____ Not Required X

Reviewed and approved by RFD [Signature] Date 9 Feb 95

RRFSC Notified [Signature] Date 01 MAR 1995

SAFETY AND HEALTH DEPARTMENT

HEALTH PHYSICS PROCEDURE 4-6.D IN PLANT RADIOLOGICAL MONITORING

**Date 08 Feb 95
Supersedes 08 Nov 94**

1. General

a. Purpose

To describe the surveys and sampling performed to document radiation and contamination levels existing outside of Reactor Controlled Areas and the TLD monitors located throughout the facility. This data can also be utilized for the assessment of occupational exposures in case of dosimetry loss or unexpected dose readings.

b. Responsibility

- (1) SHDH: Responsible for collecting and issuing the facility and perimeter inplant TLD's and for performing the various health physics surveys and sampling.
- (2) SHDD: Responsible for providing calibrated instrumentation, radioanalysis support, and facility in-plant TLDs.

2. References

a. Regulatory

- (1) 10 CFR, Parts 20 and 30.50
- (2) USNRC Licenses 19-08330-02 and 19-08330-03

b. Technical

- (1) Hendee, Radioactive Isotopes in Biological Research, pg. 242, 1973
- (2) USNRC Regulatory Guide 8.23, Radiation Safety Surveys at Medical Institutions, 1981

3. Definitions

- a. Facility in-plant TLDs: TLDs supplied by the Naval Dosimetry Center which are used within the AFRRRI complex to monitor for gamma or neutron radiation.
- b. Perimeter in-plant TLDs: TLDs supplied by the Naval Dosimetry Center which are used on the roof and building perimeter of AFRRRI to monitor for gamma radiation.
- c. Facility background TLD: TLDs supplied by the Naval Dosimetry Center which are used as the background control for the facility in-plant TLDs.
- d. Perimeter background TLDs: TLDs supplied by the Eberline, Inc. which are used as the background control for the perimeter in-plant TLDs and the environmental TLDs.
- e. Survey: An assessment of radiation levels or radioactivity concentrations and/or levels by a means (i.e., smears, direct reading instruments) appropriate to the specific set of conditions.

4. Procedures

a. Facility In-plant TLDs

- (1) Fifty facility in-plant TLDs are maintained at locations as shown in enclosure 1(a-d). Two TLDs are located on the waste compactor and desk, respectively, in the Radiological Waste Facility. Four TLDs are used for quality control purposes. At least one TLD is maintained for control (background) purposes in room 1427.
- (2) SHDH shall distribute TLDs to their respective stations within 5 working days of receipt from SHDD. The date of their distribution shall be entered into the appropriate spreadsheet file at that time. Quality control TLDs shall be dosed to 30 and 100 mrem respectively (see HPP 5-7) at the time the TLDs are distributed to their stations.
- (3) The TLD cycle shall coincide with every other SHD personnel dosimetry change schedule (approximately every 13 weeks). SHDH shall collect all facility in-plant TLDs within a 24 hour period. The date of TLD collection shall be entered into the appropriate spreadsheet file at that time. Two additional quality control TLDs shall be dosed to 30 and 100 mrem respectively within 24 hours of TLD collection.

(4) SHDH shall return the TLDs to SHDD for shipment and processing at the Naval Dosimetry Center.

(5) Upon receipt of the dosimetry report, SHDD shall immediately forward the results for the in-plant and control TLDs to SHDH. The QUATTRO PRO spreadsheet FACILXX.TLD (where XX indicates the calendar year) shall be used to tabulate the results in a summary format. TLDs that are lost or damaged shall have results entered into the spreadsheet as "lost".

(6) The dose under the "Deep Dose Equiv Photon" column of the report shall be entered for all TLDs. TLDs #48 through 57 shall have the dose under the "Deep Dose Equiv Neutron" column of the report entered. The spreadsheet indicates when to notify the RSO should any action levels or limits be exceeded.

(7) Attach a copy of the dosimetry report to the spreadsheet report and route through the RSO before committing .io file.

b. Perimeter In-plant TLDs

(1) Sixteen perimeter in-plant TLDs are maintained at locations on the roof and building perimeter of AFRR1 as shown in enclosure 2.

(2) TLDs shall be distributed by SHDH to their respective stations within 5 working days of receipt. The date of distribution shall be entered into the appropriate spreadsheet at that time. Quality control TLDs (#66 and 67) shall be dosed to 30 and 100 mrem respectively (see HPP 2-1 and 5-7) at the time the TLDs are distributed to their stations.

(3) The distribution and retrieval of the TLDs shall coincide with the Facility In-plant TLD change. SHDH shall collect all perimeter in-plant TLDs within a 24 hour period. Quality control TLDs # 68 and 69 shall also be dosed to 30 and 100 mrem, respectively within the 24 hour collection period. The date of collection shall be entered into the appropriate spreadsheet file at the time of collection.

(4) SHDH shall use the QUATTRO PRO spreadsheet PERIMIXX.TLD (where XX indicates the year of the report) to tabulate and calculate the net doses to the TLD stations. TLDs that are lost or damaged shall have "lost" entered into the spreadsheet where the results would normally have been entered. Ensure that the badge # indicated on the Eberline and Naval Dosimetry Center TLD reports coincides with the TLD # listed in the spreadsheet when TLDs have been lost or damaged. The spreadsheet indicates when to notify the RSO should any action levels or limits be exceeded.

(5) Attach a copy of the TLD report to the spreadsheet report and route through the RSO before committing to file.

c. Radiation Area and Continuous Air Monitors

Radiation Area Monitors and Continuous Air Monitors are located throughout the AFRRI complex. These instruments shall be maintained and calibrated according to HPPs 7-2 and 7-3, respectively.

d. Routine Surveys

(1) The surveys listed in enclosure 3 shall be conducted at the frequency indicated. Survey types denoted by "D", "S", and "P" indicate a survey with a direct reading portable survey instrument, a smear survey, and sampling/radioanalysis, respectively.

(2) All routine radiological surveys shall be conducted according to guidance set forth in HPP 8-1, "Radiological Survey Techniques" and any other reference HPP specified in enclosure 3. The surveyor shall also perform the following functions and make written notations as appropriate on the survey form.

(a) Review previous SHDH survey results to determine patterns or problem areas. Survey posted storage locations, benches, centrifuges, hoods, lead pigs, radioactive and regular waste containers, sinks and the floor outside the entrance to the lab.

(b) Any count rate or exposure rate above background observed during a direct reading survey shall be identified as to its source. If necessary, smears shall be taken to determine if removable contamination exists.

(c) Consult with lab personnel regarding type and activity of isotopes used and locations of use/storage in the lab. Observe lab personnel for proper handling of radionuclides (i.e., no mouth pipetting), proper dosimetry being worn, and any consumption of food/drink within the lab.

(d) If a survey instrument is required to be maintained in the lab, verify an operational and calibrated survey meter is present.

(e) Ensure that the warm drains are open in rooms where radioactive animals are housed and that cages and the entrance to the room are properly posted as a radioactive materials area and, if appropriate as a radiation area.

(f) Check labelling and postings of lab entry door, hoods, radioactive waste receptacles/cubitainers, sink drains, radioactive material containers, refrigerators, and any area with external radiation readings greater than 5 mrem/hr in any accessible area. Replace any worn, damaged, or faded labelling and postings.

(g) Ensure that radionuclide storage areas (i.e., refrigerators, lead caves) do not cause the presence of radiation levels above 0.5 mrem/hour in any areas adjacent to the storage area.

(h) Check all radioactive waste documentation cards to ensure they are complete and accurate.

(i) Take additional and/or random smears based on observations, conversations with lab personnel, and areas having a high potential for contamination (e.g., pipetting areas, water baths for radioactive samples).

(j) If contamination or unexpected radiation levels are found when performing a direct reading survey, inform lab personnel and date and note who was notified. Expand the scope of the survey to ensure that the detectable radiation levels are limited to a well defined area.

(3) Radioactive Animal Surveys

(a) Activated/injected radioactive animals shall be surveyed by SHDH at the time they are moved into VSD for housing or necropsy.

(b) The cages of such animals shall bear a "Caution - Radioactive Materials" tag which clearly indicates the date of irradiation or injection, and in the case of injected radioactive material, the activity and nuclide injected.

(c) The door to the VSD room housing a radioactive animal shall be posted with an AFRR Form 121, "Radioactive Animals Survey", a "Caution - Radioactive Materials" sign, and if appropriate, a "Caution - Radiation Area" sign.

(d) If the animal has been injected with H-3 or C-14, the four maximum dose rate columns on AFRR Form 121 shall be filled out as "N/A, H-3/C-14 Injected".

e. Non-Routine Surveys

Non-routine and unusual incident surveys shall be conducted by SHDH personnel. The RSO shall determine the type of survey required and the instrumentation to be used.

f. Survey Documentation

(1) Results of all surveys which require radioanalysis shall be documented on AFRRR Form 144 (enclosure 4).

(2) Surveys listed in enclosure 3 that have HPP's 4-4 or 4-6 as a reference shall be documented in SHD files as follows:

(a) A floor plan of the Rad Waste Facility areas (including the pump house) where radioactive materials and large sources are present shall indicate where direct and smear surveys are to be taken.

(b) A floor plan of the LINAC facility areas where radiation levels may exist due to activation shall indicate where direct and smear surveys are to be taken.

(c) A listing of the radiation levels in the immediate areas of the Cobalt Pool purification system, specifically the prefilter and resin containers.

(d) Direct neutron and gamma surveys of the top, side, and plug area of the Cf-252 irradiator shall be performed.

(e) Direct neutron and gamma surveys of the top and sides of the Pu-Be source shall be performed. The highest reading obtained from the survey of the sides shall be recorded.

(f) A listing and/or floor plan of the laboratory areas where radioactive materials and radioactive animals are present shall indicate where direct and smear surveys are taken. Any radioactive material storage area that is not an integral part of a posted area shall also be indicated on the floor plan.

(g) A listing and/or floor plan of "public" areas throughout the institute shall indicate where smear surveys are taken.

(3) The location of any surveys or sampling taken in addition to those documented in (a) through (g) above shall be recorded on the respective floor plan/listing or if appropriate, part B of AFRRRI Form 144. Radioactive animal room surveys shall be documented using AFRRRI Form 121.

(4) Results of leak testing, X-ray unit surveys, and shielding surveys require documentation via a Memorandum for Record (MFR). Documentation of leak tests shall include the results and whether or not action levels (as specified in HPP 0-2) were exceeded. Documentation of the X-ray survey shall include, at a minimum, a detailed description of the survey performed, what instruments were used, and what radiation levels were present.

(5) Documentation required for non-routine and unusual incident surveys shall be specified by the RSO on a case by case basis.

g. Survey Evaluation

(1) The SHDH individual who performs a survey is responsible for ensuring the radioanalysis results are evaluated with respect to the action levels in HPP 0-2.

(2) Smear and sampling surveys that indicate contamination or radioactivity levels above action levels shall be followed up with a complete survey of the lab/area of concern. SHDH shall inform personnel who work in the area as to the results of such surveys.

(3) Direct reading surveys which indicate radiation levels above background that cannot be identified as to their source shall be brought to the attention of Chief, SHDH.

5. Enclosures

- a. Enclosure 1(a-d): Facility In-Plant TLD Locations
- b. Enclosure 2: Perimeter In-Plant TLD Locations
- c. Enclosure 3: Routine Radiological Surveys
- d. Enclosure 4: AFRRRI Form 144, Part B
- e. Enclosure 5: AFRRRI Form 121, Radioactive Animals

no changes made

Facility Modification Worksheet 2

No 10 CFR 50.59 Analysis Required
Add a section to Procedure 8, TAB A

Proposed Change _____

Modification to: Procedure XXX Facility _____ Experiment _____

Submitted by: George Date 23 Feb 95

1. Description of change:

The change to this procedure adds a section on malfunction log entries. This section specifies a format to follow for consistency in entering malfunction entries. The new keywords to be used are SYMPTOM, RFD NOTIFIED, DIAGNOSIS, SOLUTION, OPERATIONAL VERIFICATION AND/OR CALIBRATION.

2. Verify that the proposed change does not involve a change to the Technical Specifications, the facility as described in the SAR, or procedures as described in the SAR, and does not produce an unresolved safety question as defined in 10 CFR 50.59(a)(2).

NONE.

3. If change involves a facility modification, attach a drawing if appropriate. If structural facility drawings need updating, forward a copy of changes necessary to Logistics.

4. Determine what other procedures, logs, or training material may be affected and record below.

NONE

5. List of associated drawings, procedures, logs, or other materials to be changed:

6. Create an Action Sheet containing the list of associated work specified above, attach a copy, and submit it to the RFD.

Action Sheet: Submitted _____ Not Required XXX

Reviewed and approved by RFD Wheeler Date 23 FEB 1995

RRFSC Notified B. K. M. G. Date 01 MAR 1995

LOGBOOK ENTRY CHECKLIST**I. Operational Logbook**

1. The reactor operations logbook is a before-the-fact record, that is, entries will be logged before the operator actually performs the planned function. Any late entries will be so noted.
2. The operations logbook will have a hardbound cover and will be sequentially numbered by volume. The pages will be dated at the top of each page and each page will be sequentially numbered.
3. The Reactor Facility Director (RFD) will review each logbook upon its completion; he will make an appropriate entry in the back of the logbook and sign the entry. The operator who makes the final entry at the end of a logbook is responsible for ensuring that the ROS is notified that the logbook is ready for RFD review.
4. All items in GREEN (see below) that are not closed out during the working day will be carried in GREEN at the end of the day and again at the beginning of the next operational day.
5. The entries will be made in ink and in accordance with the following designated color code:
 - a. **BLACK and BLUE-BLACK:**
 - (1) Console locked and unlocked. The individual at the console will enter his/her name and the supervisory licensed operator's name, if necessary.
 - (2) Checklist number and completion time.
 - (3) Power level at criticality and subsequent power level changes.
 - (4) Reactor SCRAM.
 - (5) Mode of operations. Use appropriate stamp or entry to designate the operation:
 - (a) Steady State
 - (b) Square Wave
 - (c) Pulse

(6) Operation of reactor associated facilities such as lead shield doors, pneumatic tube systems, etc., unless such operations cause a change of reactivity (see 5.b.(2) below).

(7) Change of personnel at the console. Name of personnel will be entered along with the licensed operator present in the control room, if the person at the console is not a licensed operator.

(8) The operator in charge will be designated in the logbook whenever multiple operators are signed on the console.

(9) Completion of the daily startup and shutdown checklists and weekly checklist.

(10) Signature of reactor operator to close out the log for the day.

(11) Designation of the SRO on-call and physicist in charge (PIC).

(12) Reactor calibrations and data.

(13) All line outs, entry errors, changes in mode of operation stamp lines, and end of page line outs will be initialed or signed by the operator.

b. RED:

(1) K-excess measurements, to include experiment worth determinations.

(2) Actions which affect reactivity:

(a) Core movement.

(b) Fuel movement.

(c) Control rod physical removal for maintenance.

(d) Experiment loading and removal from the CET, PTS, pool, or core.

c. GREEN:

(1) Any reactor malfunctions noted upon discovery/occurrence with a second entry noting corrective action has been completed.

(2) Additional items entered at the discretion of the operator such as addition of make-up water to the reactor pool, etc.

(3) Any Technical Specification required equipment taken out of service for any reason. A second entry is made when the unit is returned to service.

6. When an operation requiring entry into the logbook falls under more than one color code, the color to be used will be determined via the following order of precedence: RED - GREEN - BLACK/BLUE-BLACK.

II. Malfunction Logbook

All entries in the malfunction logbook should include the following information. For consistency, the bold italic words should be copied into the malfunction log prior to the information.

DATE, TIME, SIGNATURE OF PERSON DISCOVERING MALFUNCTION

SYMPTOM: of problem

This section describes how the system is acting or malfunctioning. I.E. channel went full scale, pump failed, keyboard stopped responding to keystrokes etc.

IMMEDIATE ACTION TAKEN

This section is for denoting such things as Reactor Secured, SHD notified.

RFD NOTIFIED:

A remark should be made that the RFD or acting RFD was notified.

DIAGNOSIS : of problem

A narrative description of what was discovered to be causing the problem. I.E. Which system was malfunctioning or which component failed.

SOLUTION: / repair

A narrative description of what was done to correct the problem This could include both physical changes or administrative changes. I.E. A component was replaced and the unit was recalibrated, an additional backup system installed, an administrative prohibit on ... was initiated.

OPERATIONAL VERIFICATION AND/OR CALIBRATION:

A description of what actions were taken to verify that the new unit/repair would indeed perform the intended function for which it was intended. I.E. A calibration signal, system actuated multiple times, system tested, system calibrated with a source, Indicate whether the change will require staff training.

SIGNATURE RFD

Facility Modification Worksheet 2

No 10 CFR 50.59 Analysis Required

Proposed Change HPP 3.1, "Reactor Irradiation Facilities"
Modification to: Procedure X Facility Experiment
Submitted by: O'BRIEN Date 12 May 95

1. Description of change:
CAM Level readings ^{changed} for monitored +
non-monitored openings.

2. Verify that the proposed change does not involve a change to the Technical Specifications, the facility as described in the SAR, or procedures as described in the SAR, and does not produce an unresolved safety question as defined in 10 CFR 50.59(a)(2). Done

3. If change involves a facility modification, attach a drawing if appropriate. If structural facility drawings need updating, modification of drawings must be approved by RFD and forward a copy of changes necessary to Logistics. N/A

4. Determine what other procedures, logs, or training material may be affected and record below. None

5. List of associated drawings, procedures, logs, or other materials to be changed:
None

6. Create an Action Sheet containing the list of associated work specified above, attach a copy, and submit it to the RFD.

Action Sheet: Submitted Not Required

Reviewed and approved by RFD [Signature] Date 10 JUN 1995

RRFSC Notified [Signature] Date JUN 2 1995

Facility Modification Worksheet 2

No 10 CFR 50.59 Analysis Required

Proposed Change HPP 7-3, "Airborne Radioactivity Samplers & Monitors"

Modification to: Procedure X Facility Experiment

Submitted by: O'BRIEN Date 15 Feb 95

1. Description of change:

*procedure updated to reflect Table 4.9(1)
Cam locations and Settings*

2. Verify that the proposed change does not involve a change to the Technical Specifications, the facility as described in the SAR, or procedures as described in the SAR, and does not produce an unresolved safety question as defined in 10 CFR 50.59(a)(2). *DONE*

3. If change involves a facility modification, attach a drawing if appropriate. If structural facility drawings need updating, modification of drawings must be approved by RFD and forward a copy of changes necessary to Logistics. *N/A*

4. Determine what other procedures, logs, or training material may be affected and record below. *Reactor Procedure 1, TAB A "Reactor E.R. Entry"*

5. List of associated drawings, procedures, logs, or other materials to be changed:
N/A

6. Create an Action Sheet containing the list of associated work specified above, attach a copy, and submit it to the RFD.

Action Sheet: Submitted Not Required X

Reviewed and approved by RFD *[Signature]* Date 01 JUN 1995

RRFSC Notified *[Signature]* Date JUN 2 1995

SAFETY AND HEALTH DEPARTMENT

HEALTH PHYSICS PROCEDURE 7-3.C AIRBORNE RADIOACTIVITY SAMPLERS AND MONITORS

**Date 15 Feb 95
Supersedes 06 May 94**

1. General

a. Purpose and Scope: This HPP describes the operation, calibration, and maintenance procedures required for the Continuous Air Monitors (CAMs), Reactor Stack Gas Monitor (SGM), and portable air sampling equipment.

b. Responsibility

(1) SHDH is responsible for performing a daily check on all CAMs except those required by NRC license R-84.

(2) SHDD is responsible for maintenance and calibration of all portable air sampling equipment, and maintenance, calibration, and channel testing of all CAMs not required by the R-84 license. SHDD shall provide calibration support to RSDR for R-84 license required CAMs and the Reactor SGM.

(3) LOGI is responsible for routine preventive maintenance and electronic calibration support for CAMs and the Reactor SGM upon request.

(4) RSDR is responsible for performing daily checks and channel tests of R-84 license required CAMs and the Reactor SGM.

2. References

a. Regulatory

(1) 10 CFR 20.1202, 1203, 1204, 1301, and 1302.

(2) Appendix B to 10 CFR 20.1001 - 20.2402.

(3) NRC License R-84, Technical Specifications

(4) AFRRRI Instruction 3020.2 "AFRRRI Emergency Evacuation and Fire Plan"

b. Technical

- (1) Barnes, David, "Radiation Hazards and Protection" 1963
- (2) DF dated 20 Sep 78, J. Arras, "TRIGA Emergencies, Dose Estimates"
- (3) DF dated 01 Mar 83, W. Webber, "CAM Alarm Settings"
- (4) CF-970T Series Air Sampling Pump Manual
- (5) Nuclear Measurements Corporation Model AM-22IB-P Radiation Monitoring System Instruction Manual
- (6) DF dated 29 Nov 71, J. Arras, "Reactor Deck CAM Readings"
- (7) DF dated 20 Aug 80, L. Slaback, "Reactor Emergency Alarm Points"

3. Definitions

a. Continuous Air Monitor (CAM): A CAM consists of a mobile rack-mounted chart recorder, air pump, shielded G-M detector, adjustable alarm settings, flow rate indicator, analog count rate meter, and associated electronics. The unit also has a control valve to maintain constant air flow as well as to adjust for a specified air flow rate. The CAM is designed to monitor and record airborne gaseous and particulate radioactivity on a continuous basis.

b. Stack Gas Monitor (SGM): The reactor stack gas monitoring system uses a multi-nozzle probe to sample the exhaust air in the reactor ventilation system which is drawn through a detector chamber to determine the average concentration of Ar-41 in the exhaust air.

c. Portable Air Samplers: Units designed to collect particulates from the air onto a filter for subsequent radioanalysis.

d. Channel Test: The introduction of a signal (i.e., exposure of the CAM detector to a radiation field) to verify the instrument is operable.

4. Procedures

a. CAM Operation

(1) CAM locations and Settings

| Location | High Alarm (cpm) | Low Alarm (cpm) | Fail Alarm (cpm) | Chart/Pen Recorder* |
|----------------------|------------------|-----------------|------------------|---------------------|
| Reactor Deck-Primary | 10K | 4K | --- | On |
| Reactor Deck-Backup | 10K | 4K | --- | Off |
| Prep Area | 2K | --- | 50 | Off |
| Exposure Room 1 | 50K | --- | 50 | Off |
| Exposure Room 2 | 50K | --- | 50 | Off |
| ERC 1** | 2K | --- | 50 | Off |
| ERC 2 | 2K | --- | 50 | Off |

* During emergency conditions the RSO/RFD may direct the recorders on additional CAMs be activated.

** Used in front lobby during potential radiological emergencies.

(2) Daily Check

SHDH shall perform a check as described below on the CAMs specified in 1.b.(1)

(a) Change the CAM filter by opening by the detector cover and removing the filter using tweezers. Replace it with a NMC glass fiber filter (part #0965942) and place the used filter in a box/bag labelled as radioactive material which is located in the drawer of the CAM. Used filters may be stored in the CAM drawer but should be disposed of as radioactive waste at least monthly.

(b) Check the CAM with the internal test pulser by flipping the switch located on the face of the monitor from OP to TEST. The observed count rate on the analog meter must be within $\pm 20\%$ of 3600 counts per minute.

(c) It may be necessary to gently tap on the chart wheel or meter face to ensure that the pin and meter needle have freedom of motion.

(d) Return the switch to OP.

(e) Observe the flow rate value on the magnehelic gauge. If it is off-scale or less than 6 CFM, notify Chief, SHDD.

(f) Document the daily check using enclosure 1a.

(g) Whenever chart paper is removed from the CAM, it and its storage box shall be labelled with the date of removal, the location, and serial number of the CAM. Put the expended chart paper in the box which contained the new roll of chart paper and place it in room 1120 (warm storage) for storage.

(j) Any CAM found to be malfunctioning or inoperable shall be immediately tagged out of service and Chief, SHDD shall be notified.

(3) Calibration and Channel Testing

(a) Frequency

1. All R-84 license required CAMs shall be calibrated every 6 months not to exceed 9 months, and channel tested every 3 months not to exceed 4 months. RSDR shall contact SHDD to arrange for any calibration support necessary to meet the required frequency.

2. All other operational CAMs within AFRRRI shall be calibrated every 6 months, and channel tested every 3 months, not to exceed 4 months.

3. A flow calibration shall be performed on all CAMs every 6 months.

(b) Electronic Calibration

1. An electronic calibration shall be performed before every isotopic calibration. This calibration, along with preventive maintenance, is performed by an outside contractor.

2. Observed values indicated by the analog meter and the chart recorder shall be within $\pm 20\%$ of the input test values of 100, 1000, and 10000 cpm.

Facility Modification Worksheet 2

No 10 CFR 50.59 Analysis Required

Proposed Change Procedure A2, "Personnel Passage Through the Prep Area"
Modification to: Procedure X Facility Experiment
Submitted by: McClung Date 25 May 95

1. Description of change:

Adds specific section on
Prep area Frisking Policy/Procedure.

2. Verify that the proposed change does not involve a change to the Technical Specifications, the facility as described in the SAR, or procedures as described in the SAR, and does not produce an unresolved safety question as defined in 10 CFR 50.59(a)(2). DONE

3. If change involves a facility modification, attach a drawing if appropriate. If structural facility drawings need updating, modification of drawings must be approved by RFD and forward a copy of changes necessary to Logistics. N/A

4. Determine what other procedures, logs, or training material may be affected and record below. None

5. List of associated drawings, procedures, logs, or other materials to be changed:
None

6. Create an Action Sheet containing the list of associated work specified above, attach a copy, and submit it to the RFD.

Action Sheet: Submitted Not Required X

Reviewed and approved by RFD Mh by Date 01 JUN 1995

RRFSC Notified DJK MG Date JUN 2 1995

PERSONNEL PASSAGE THROUGH THE PREP AREA**GENERAL**

Access to the Reactor Prep Area is limited to personnel who are granted access in accordance with the reactor physical security plan and Operational Procedure 1. The Reactor Facility Director is responsible for maintaining an unescorted access roster for the Reactor Prep Area and for providing a Prep Area briefing to all persons listed on that roster. This administrative procedure does not recapitulate the operational procedure. Rather, it presents specific guidelines for Reactor Prep Area passage, and frisking for individuals who are authorized access.

SPECIFIC**1. ROUTINE PASSAGE: (EXPOSURE ROOM DOORS CLOSED)**

- a. Personnel who are authorized unescorted access to the Reactor Prep Area may pass through the Prep Area as necessary.
- b. Personnel who are being escorted through the Reactor Prep Area may pass through the Prep Area only with their escort.
- c. Only appropriate personal dosimetry that has been issued by SHD or AFRRRI Security is required for routine passage through the Reactor Prep Area. There is no requirement to wear a pocket chamber in addition to the AFRRRI issued TLD for routine passage.

2. CONTROLLED PASSAGE: (EXPOSURE ROOM DOOR OPEN)

- a. Only personnel associated with the experiment/operation being performed are normally authorized access to the Reactor Prep Area during an exposure room opening. These personnel will be required to wear the AFRRRI TLD dosimeter (issued with their AFRRRI badge), pocket chamber (if dose rate at face of door is 2 mr/hr or more), and AFRRRI wrist dosimeter or finger ring dosimeter if they enter the exposure room.

All personnel who enter an exposure room will log their pocket chamber reading in the pocket chamber log prior to entering the room for the first time that day and will enter the final pocket chamber reading following their exit from the exposure room at the end of the day. Each individual who enters an exposure room is responsible for monitoring his accumulated dose throughout the day to ensure the he/she does not exceed the AFRRRI daily

exposure limits of 50 mrem/day or 100 mrem/week. Extremity dosimetry is required only if work is to be performed on an experimental array or within 1 meter of the core projection.

- b. Personnel authorized unescorted access to the Reactor Prep Area or personnel being escorted through the Reactor Prep Area may pass through the Prep Area when an exposure room is open with permission from the reactor staff person in charge during the opening if the following guidelines are met:

The person desiring passage must stop just inside the Prep Area door upon seeing that an exposure room door is open and request permission from the reactor staff member in charge before proceeding. At that time, the reactor staff and safety staff members monitoring the exposure room opening will determine if the radiation level at the outside entrance to the exposure room in direct line of sight with the core projection is less than or equal to 2 mrem/hr. If this reading is less than or equal to 2 mrem/hr, the reactor staff member may grant passage permission. There is no requirement to wear a pocket chamber in addition to the AFRRRI issued TLD for control passage. If the reading is greater than 2 mrem/hr, passage will be denied.

3. OPEN PASSAGE: (NON-ROUTINE)

The Prep Area may be opened for passage by personnel traveling between buildings at AFRRRI when maintenance is being performed on the normal connecting hallway. This is not a routine occurrence and warrants written approval from the Reactor Facility Director with concurrence from the Chairman, Safety and Health Department. In addition, the Prep Area must be monitored at all times by appropriately trained personnel. Prior to the opening of the Reactor Prep Area for open passage, the Safety and Health Department shall conduct a radiological survey of the area and certify that no radiation areas exist within the Prep Area and that the non-painted areas of the Prep Area floor are free of contamination. There is no requirement for personnel who pass through the Prep Area to wear pocket chambers or frisk themselves during periods of open passage. Open passage will be suspended during exposure room openings.

4. FRISKING

Frisking upon exit from the Prep Area is only required for the following conditions:

- a. Personnel who have entered the yellow painted work zone area.
- b. Personnel who have been in either exposure room.
- c. Personnel who may have handled potentially contaminated material.

d. Upon request of reactor staff or SHD personnel.

The frisking procedure is posted at both exits from the Prep Area near the survey instruments.

Facility Modification Worksheet 2

No 10 CFR 50.59 Analysis Required

Proposed Change Procedure 11, "Air Particulate Monitor (CAM) Procedure"
Modification to: Procedure X Facility Experiment
Submitted by: McClung Date 25 May 95

1. Description of change:

Implements changes to use of Secondary CAM chart recorder. Also includes change to Channel Test reading for new electronics module in SECONDARY CAM.

2. Verify that the proposed change does not involve a change to the Technical Specifications, the facility as described in the SAR, or procedures as described in the SAR, and does not produce an unresolved safety question as defined in 10 CFR 50.59(a)(2). *DONE*

3. If change involves a facility modification, attach a drawing if appropriate. If structural facility drawings need updating, modification of drawings must be approved by RFD and forward a copy of changes necessary to Logistics. *N/A*

4. Determine what other procedures, logs, or training material may be affected and record below. *NONE*

5. List of associated drawings, procedures, logs, or other materials to be changed: *NONE*

6. Create an Action Sheet containing the list of associated work specified above, attach a copy, and submit it to the RFD.

Action Sheet: Submitted Not Required X

Reviewed and approved by RFD *[Signature]* Date 01 JUN 1995

RRFSC Notified *[Signature]* Date JUN 2 1995

AIR PARTICULATE MONITOR(CAM) PROCEDURE

GENERAL

This procedure specifies how to test the CAM to ensure proper operation of this monitoring device. A channel test will be performed on both reactor room CAMs at the beginning and end of each day.

SPECIFIC

1. OPERATING and TRACING

Check that the primary CAM is operating and tracing with the correct time indicated on the chart and check that the secondary CAM is operating. Ensure the flow rate is >6 cfm and not off scale.

2. CHANNEL TEST WITH SOURCE

- a. Place the switch on the front of the CAM to "test" and verify a reading of 3600 cpm +/- 20% for primary CAM on the chart and 1000 cpm for the secondary CAM. Reset the switch.
- b. Open shield door and change the detector filter if the filter appears excessively dirty or the flow rate has dropped below 6 cfm. Place the used filter in the radioactive waste box in each CAM drawer.
- c. Slowly bring a radioactive source near the detector. Observe the meter on the front of the CAM. The yellow light will activate at approximately 4,000 counts per minute. The red light will activate at approximately 10,000 counts per minute; the alarm will sound and the dampers will close. Reset the alarm, close the chamber door and return the source to the CAM drawer.
- d. Annotate completion of the channel test on chart paper with initials, time, and date performed for primary CAM only.

3. TEST FREQUENCY

This entire procedure will be performed in conjunction with the daily startup or safety checklist. Items 1 and 2a will be performed again as part of the daily shutdown checklist.

4. BY-PASS of PRIMARY CAM

When the primary CAM is by-passed, the secondary CAM chart recorder needs to be activated, then perform items 1, 2a, and 2d.

Facility Modification Worksheet 2

No 10 CFR 50.59 Analysis Required

Proposed Change Auxillary Damper Reset Switch

Modification to: Procedure Facility X Experiment
Submitted by: George Date 25 MAY 95

1. Description of change:

Additional reset switch added in Reactor Foyer. To be used by AFRRF Security Guards, when directed by Reactor Staff.

2. Verify that the proposed change does not involve a change to the Technical Specifications, the facility as described in the SAR, or procedures as described in the SAR, and does not produce an unresolved safety question as defined in 10 CFR 50.59(a)(2). Done

3. If change involves a facility modification, attach a drawing if appropriate. If structural facility drawings need updating, modification of drawings must be approved by RFD and forward a copy of changes necessary to Logistics.

4. Determine what other procedures, logs, or training material may be affected and record below. None

5. List of associated drawings, procedures, logs, or other materials to be changed: None

6. Create an Action Sheet containing the list of associated work specified above, attach a copy, and submit it to the RFD.

Action Sheet: Submitted Not Required X

Reviewed and approved by RFD [Signature] Date 25 MAY 1995

RRFSC Notified [Signature] Date 02 JUN 1995

Facility Modification Worksheet 2

No 10 CFR 50.59 Analysis Required

Proposed Change Procedure 1, TAB A, "Reactor Exposure Room Entry"
 Modification to: Procedure X Facility Experiment
 Submitted by: McClung Date 25 May 95

1. Description of change:

ER CAM reading changed for Non-monitored Opening (4.a.(3))

2. Verify that the proposed change does not involve a change to the Technical Specifications, the facility as described in the SAR, or procedures as described in the SAR, and does not produce an unresolved safety question as defined in 10 CFR 50.59(a)(2). *Done*

3. If change involves a facility modification, attach a drawing if appropriate. If structural facility drawings need updating, modification of drawings must be approved by RFD and forward a copy of changes necessary to Logistics. *N/A*

4. Determine what other procedures, logs, or training material may be affected and record below. *None*

5. List of associated drawings, procedures, logs, or other materials to be changed: *None*

6. Create an Action Sheet containing the list of associated work specified above, attach a copy, and submit it to the RFD.

Action Sheet: Submitted Not Required X

Reviewed and approved by RFD *McClung* Date 01 JUN 1995

RRFSC Notified *[Signature]* Date OCT 18 1995

REACTOR EXPOSURE ROOM ENTRY

1. REFERENCES

- a. 10 CFR 20, "Standards for Protection Against Radiation"
- b. USNRC licenses: R-84, 19-08330-02
- c. AFRRRI Instruction 6055.8
- d. AFRRRI Health Physics Procedure 3-1

2. GENERAL

a. **PURPOSE:** This procedure specifies all safety and security procedures for activities involving entry into the AFRRRI TRIGA Reactor exposure rooms, currently designated exposure rooms 1 and 2 (rooms 1123 and 1122).

b. **AUTHORIZED ENTRY:** Both AFRRRI picture badge and U-badge personnel, may enter a reactor exposure room under the supervision of the Reactor Facility Director (RFD) or his representative. Visiting personnel (V badge) require special authorization by both the Chairman, Safety and Health Department (SHD) and RFD to enter either exposure room. In general, permission to enter the exposure rooms will be granted personnel whose duties require such entry; however, permission may be denied to personnel for serious or repeated safety or security violations, or for safety reasons emanating from conditions in the exposure rooms. All personnel who are granted unescorted access to the prep area or warm storage will receive a special prep area safety briefing prior to being granted access. Only personnel who have been granted permanent unescorted access will be given card access to the prep area. The RFD is responsible for maintaining a roster in the prep area for personnel who have been granted permanent unescorted access. Other personnel requiring unescorted access to the prep area or warm storage for a specific purpose or time period may be granted special access in writing by the RFD with concurrence of SHD. However, these personnel who are granted special access from the RFD will not be given card access to the prep area.

c. **ER ENTRY INSTRUCTIONS** - All personnel will:

- (1) Know the Reactor staff representative is in charge of all operations in the prep area. Obtain permission to enter either exposure room from the Reactor staff representative.
- (2) Wear AFRRI TLD whole body badge and pocket dosimeter.
- (3) Wear wrist or finger dosimeter if work is to be performed on an experimental array or within one meter of the core projection.
- (4) Wear booties, eye protection, gloves and coat.
- (5) Check and log pocket dosimeter reading on log in prep area prior to entry.
- (6) Familiarize themselves with approximate radiation levels in the room, based on radiological surveys performed and data obtained by SHD.
- (7) Ensure that all materials removed from the exposure room are properly labeled and entered on the exposure room entry log (AFRRI FORM 130) and the activated materials control log.
- (8) Glove and lab coat requirements may be waived by the SHD monitor or reactor representative on an individual basis for personnel who will not be touching anything in the exposure room. There must be a specific reason for waiving such requirements.

d. DEPARTURE FROM REACTOR EXPOSURE ROOM ENTRY

PROCEDURES: Any departure from the following procedures will require a special work permit (SWP). Exceeding any radiation dose limits will require a written justification from the supervisor of the research project which must be approved by the Head, SHD.

3. SHD EXPOSURE ROOM SURVEY

a. EXPOSURE ROOM CAM:

- (1) Prior to opening either exposure room, the respective CAM must read 2000 cpm or less. If the CAM reads 2000 cpm or greater, change the filter on the CAM and put it in the radioactive materials bag in the CAM drawer. If 10 minutes or more have elapsed since the end of the reactor run, the door may be opened to the first step to facilitate radio effluent clearance in the room. Then check the CAM after 1 minute and, if the reading has not increased by more than 100 cpm, proceed with the exposure room opening. If it has increased by more than 100 cpm, change the filter and wait two more minutes and repeat as necessary. If the CAM alarms during or immediately after a run, change the filter and reset the CAM.
- (2) If either exposure room CAM or the Prep Area CAM is found malfunctioning or inoperable, notify the Reactor Representative or

Reactor Operations Supervisor (ROS) and Radiation Safety Officer (RSO) immediately. No opening shall be initiated if the exposure room to be opened does not have an operable CAM.

b. **DOSE RATE AT FACE OF DOOR:** If the dose rate at the face of the plug door in the direct line of sight of the reactor tank bulge reads greater than 100 mrem/hr, the door will be closed sufficiently to preclude access. The plug door will be reopened upon agreement of the SHD and RFD representatives for reevaluation of radiation levels. When the dose rate at the face of the door is below 100 mrem/hr, the opening procedure may continue.

c. **DOSE LEVELS IN ROOM:** Exposure rates will be measured at specific sites in the rooms. These measurements will be given to both the reactor representative and the personnel entering the room. Additionally the readings will be entered in the room entrance log (AFRRI FORM 130) and kept in the prep area. The levels will be measured at:

- (1) The reactor door face in the direct line of sight of the reactor tank bulge
- (2) At the contamination line in the entrance of the room
- (3) The middle of the room
- (4) 30 cm from the tank wall or shield
- (5) Contact with the tank wall or shield
- (6) The area(s) where individual(s) will be working for an extended period of time and any other place deemed necessary by the reactor representative.

d. **ROUTINE ENTRY:** Entry is routinely permitted only when the maximum reading in any occupiable area is 1 rem/h or less. Entry may be permitted if levels are 1-5 rem/h, but no work will be permitted in fields over 1 rem/h. If personnel are working in a specific area for an extended period of time, the dose rate in that area will be measured.

- (1) Readings over 100 mrem/hr (closed window) will be specifically identified. All dose rate readings will be reported to the Reactor representative and entry personnel. When appropriate, after consultation with the SHD and Reactor representatives, stay times will be assigned for entry personnel. AFRRI limits of 100 mrem/week and 50 mrem/day are to be used as the basis of stay time determinations.
- (2) All exposure room entries will be checked by the SHD monitor for compliance with radiation safety aspects of applicable Reactor Use Requests (RURs). If not, non-compliance will be reported to the RFD and to SHD.

e. FILLING OUT THE SURVEY OF EXPOSURE ROOM OPENING LOG:
The exposure room opening log sheet must be filled out completely for each opening of an exposure room. Care must be taken to fill out each blank on the entry log sheet. If a section is not applicable to the particular opening, N/A should be filled in the blank.

4. NON-MONITORED OPENING:

a. Personnel may enter the exposure rooms without a SHD monitor present if ALL the following conditions hold:

- (1) The reactor has not been to power in that ER since the last survey.
- (2) Survey meter readings at the door indicate safe entry conditions (should be less than 1 mrem/hr).
- (3) The ER CAM should be observed, and its reading should be less than 2000 cpm (see paragraph 3a(1)).
- (4) The last survey indicates that the maximum dose rate in any area where work is to performed did not exceed 100 mrem/hr.

b. An entry will be made in the exposure room log by a reactor staff member, with a note that the survey has been waived.

c. SHD must be notified if any radioactive materials or equipment are to be removed from the prep area.

5. PERSONNEL PROTECTION PROCEDURES

a. Dosimetry and protective clothing requirements are given in paragraph 2.c, ER Entry Instructions.

b. Entry is permitted only after the SHD monitor has completed the survey and reported results to those about to enter (excluding non-monitored openings - reference Paragraph 4, above).

c. All personnel shall record initial dosimeter reading in the prep area dosimeter log prior to entering the exposure room for the first time each day. Personnel shall read dosimeters when leaving the exposure room and record a final dosimeter reading in the prep area log at completion of daily operations. Net doses over 10 mrem must be reported to the SHD Monitor.

d. Protective clothing will be removed in such a way as not to contaminate "clean" areas by items from "dirty" areas.

e. All personnel will "frisk" themselves before leaving the prep area.

6. SPECIFIC ACTIONS TO OPEN EXPOSURE ROOM DOORS

- a. Turn up exposure room lights (this can be waived for experiment needs).
- b. Check plug door tracks for obstructions; ensure all obstacles are clear of the door (including ropes).
- c. Ensure that only authorized personnel (see 2.b.) are present in the reactor prep area during exposure room openings.
- d. When facility safety interlocks and opening procedures have been satisfied, insert key into exposure room door key panel and open door. **DO NOT LEAVE KEY IN LOCK UNATTENDED.**
- e. Open door in accordance with entry procedures. Ensure all required data is logged in entry log.
- f. Ensure that individuals who will be moving lead, bismuth, or other heavy materials are wearing steel-toed shoes.
- g. Limit exposure times of all personnel entering the exposure rooms based on the results of the radiation survey.

7. ACTIVATED MATERIALS

a. **PLACING MATERIAL IN EXPOSURE ROOM:** Before placing any equipment or material in an exposure room for irradiation the following will be observed:

- (1) Equipment tagged as AFRRRI property: a memo must be sent to both the RFD and the AFRRRI property officer. The memo must state that the equipment is knowingly being irradiated and therefore request that it be removed from the property books. It must also state that should the material remain byproduct material after a reasonable amount of time it will be disposed of as radioactive waste. The memo must contain all nomenclature as well as an adequate description of the equipment in order for it to be identified on the property book.
- (2) Non-tagged AFRRRI equipment or material (to be returned): a memo or statement on the reactor RUR must be sent to the RFD giving the kinds and amounts of byproduct material expected to be produced (that is the material that the experimenter wishes to be returned) and a copy or number of their radionuclide authorization number. The memo or RUR statement must be specific and contain an accurate description of the material being exposed (converted to byproduct). Other information will be required from personnel before any material is allowed to be removed

from the prep or warm storage areas (see next section of this procedure 7.b. and 7.c.)

- (3) Non-tagged equipment or material (not to be returned): A memo or statement on the RUR that the experimenter understands that byproduct material produced as a result of their irradiations will be disposed of as radioactive waste, and additionally any material not specifically requested to be held, will be disposed of as radioactive waste in the next shipment.
- (4) Non-AFRRI owned equipment/material: A signed memorandum from the responsible property owner that they understand that byproduct materials generated in excess of their license will be disposed of as radioactive waste unless prior arrangements have been made with the reactor/SHD staffs for storage. Any material not removed within a reasonable amount of time will automatically be disposed of as radioactive waste.

b. SURVEY OF MATERIALS COMING OUT OF EXPOSURE ROOM

- (1) All material leaving the exposure rooms must be surveyed for activation or contamination. Survey meter readings will be used to determine dose levels. Smear surveys may be used, if the SHD representative deems them necessary. All materials will be labeled appropriately in accordance with HPP 0-2 and HPP 3-1.
- (2) All special equipment that has been activated such as chambers, rotators, motors, meters, etc., will be stored under the control of the reactor license or the AFRRI byproduct license in warm storage or the prep area. Removal of items from the prep area will only be allowed in accordance with HPP 3-1.

c. DISPOSITION OF ACTIVATED MATERIALS

All activated or contaminated materials will be under the control of the reactor license while such materials remain in the reactor controlled area. Removal of any radioactive materials from the reactor controlled area will be done in accordance with HPP 3-1.

8. COMPLETION OF ENTRY

- a. The Reactor Staff Representative will check to see that all personnel have left the exposure room before the plug door is closed. In the event that the warning horn in either exposure room is disconnected, for testing or experiment requirements, the exposure room plug door shall not be closed until at least two (2) licensed reactor operators visually inspect the room to ensure that no personnel remain in the room. To ensure compliance with the reactor Technical Specifications, the names of these licensed operators present at the exposure room

closing shall be entered into the reactor operations logbook and on AFRR I FORM 130. At the completion of the test or experiment, the warning horn shall be reconnected and tested. All actions regarding the warning horn shall in entered in GREEN ink in the reactor operations logbook.

- b. The SHD monitor will not leave the area while the plug door is open without notifying the Reactor Staff Representative.
- c. Lock the exposure room door control panel; reset lights, if appropriate.
- d. Resecure the prep area on departure.

Facility Modification Worksheet 2

No 10 CFR 50.59 Analysis Required

Proposed Change REPLACEMENT OF STACK MONITORING PRT

Modification to: Procedure Facility X Experiment

Submitted by: MILLER Date 5/25/95

1. Description of change: REPLACE TUBES FROM STACK MONITORING SYSTEMS

2. Verify that the proposed change does not involve a change to the Technical Specifications, the facility as described in the SAR, or procedures as described in the SAR, and does not produce an unresolved safety question as defined in 10 CFR 50.59(a)(2). NONE

3. If change involves a facility modification, attach a drawing if appropriate. If structural facility drawings need updating, modification of drawings must be approved by RFD and forward a copy of changes necessary to Logistics.

4. Determine what other procedures, logs, or training material may be affected and record below. NONE

5. List of associated drawings, procedures, logs, or other materials to be changed: NONE

6. Create an Action Sheet containing the list of associated work specified above, attach a copy, and submit it to the RFD.

Action Sheet: Submitted Not Required X

Reviewed and approved by RFD [Signature] Date 25 May 95

RRFSC Notified [Signature] Date 22 JUN 1995

Facility Modification Worksheet 1

10 CFR 50.59 Analysis

Proposed Change Replacement of Stack Gas Monitor Printer with Chart Recorder

Submitted by: George/McClung Date 20 June 1995

1. Description of change: The Stack Gas Monitor printer is removed. A Chart Recorder will be used to record effluent counts. The Stack Gas Monitor will no longer print a report of average Ar-41 concentrations every six hours. Unusual events will be displayed in real time on the chart recorder.

2. Reason for change: Printer is no longer serviceable.

3. Verify that the proposed change does not involve a change to the Technical Specifications or produce an unresolved safety issue as specified in 10 CFR 50.59(a)(2). Attach an analysis to show this.

Analysis attached? Yes x

4. The proposed modification constitutes a changes in the facility or an operational procedure as described in the SAR. Describe which (check all that apply).

Procedure Facility x Experiment

Facility Modification Worksheet 1

5. Specify what sections of the SAR are applicable. In general terms describe the necessary updates to the SAR. Note that this description need not contain the final SAR wording.

Section 3, paragraphs 3.6.3 and 3.6.3.2 are affected by the change.

The SAR will be modified to reflect no automatic printout of average Ar-41 concentrations. It will also be modified to include use of the chart recorder continuous printout of effluent counts.

6. For facility modifications, specify what testing is to be performed to assure that the systems involved operate in accordance with their design intent.

The chart recorder has been operated in parallel with the stack gas monitor printer for several years. It has operated as intended and provides for a continuous means of recording effluent counts at the sampling point.

Facility Modification Worksheet 1

7. Specify associated information.

New drawings are: Attached
Not required

Does a drawing need to be sent to Logistics? Yes No
Are training materials effected? Yes No
Will any logs have to be changed? Yes No
Are other procedures effected? Yes No

List of items affected:

AFRRI TRIGA Reactor Operations Manual
Safety Analysis Report
Procedure C006, "Stack Gas Monitor Calibration"

8. Create an Action Sheet containing a list of associated work specified in item # 7, attach a copy, and submit another to the RFD (modification of drawings must be approved by the RFD).

Action Sheet: Submitted Not Required

Reviewed and approved by RFD

acting for
Mark
Morse

Date 6/21/95

RRFSC Concurrence

[Signature]

Date OCT 18 1995

50.59 ANALYSIS

Supported Action: Replacement of Stack Gas Monitor Printer with Chart Recorder

The Stack Gas Monitor (SGM) continues to sample and measure the effluent, as required by the Technical Specifications. The actual concentrations of Argon-41 at the sample point are still calculated and stored in computer memory. This information is available for recall on the SGM CRT at any time. The information will no longer be automatically printed every six hours. The effluent counts can be monitored on the auxiliary reactor console chart recorder. This device provides for a continuous readout and hard copy printout of the effluent counts. Interpretation of this data by a licensed operator allows the effluent situation to be evaluated at any time. The chart recorder allows for monitoring of potential unusual releases to the environment.

This change does not increase the consequences of, nor change the types of accidents previously evaluated in the Safety Analysis Report. This change does not reduce the margin of safety as defined in the bases for any Technical Specifications.

50.59 ACTION SHEET

Supported Action: Replacement of Stack Gas Monitor Printer with
Chart Recorder

1. Update SAR to reflect change to Stack Gas Monitor System.

Date Completed: _____

2. Update Operations Manual to include new Stack Gas Monitor configuration.

Date Completed: _____

3. Modify Procedure C006, "Stack Gas Monitor Calibration" to reflect necessary changes.

Date Completed: _____

Facility Modification Work Sheet 1

10 CFR 50.59 Analysis

Proposed Change: Replacement of the Stack Gas Monitor Electronics with Non-Computer Based Electronics Package

Submitted by: George

Date 07-12-95

1. Description of change:

Remove the electronics shelf in the Stack Gas Monitor and replace the computer based PIOPS electronics with a newer, more reliable shelf of analog based electronics. The new unit will have outputs for alarm lights and audible alarms as well as remote meters and chart recorders. The new unit will still have single channel capability for monitoring Argon-41.

2. Reason for change:

The old PIOPS Stack Gas Monitor electronics are no longer cost effective to maintain.

3. Verify that the proposed change does not involve a change to the Technical Specifications or produce an unresolved safety issue as specified in 10 CFR 50.59(a)(2). Attach an analysis to show this.

Analysis attached? Yes XXX

4. The proposed modification constitutes a changes in the facility or an operational procedure as described in the SAR. Describe which (check all that apply).

Procedure XXX Facility XXX Experiment

Facility Modification Work Sheet 1

5. Specify what sections of the SAR are applicable. In general terms describe the necessary updates to the SAR. Note that this description need not contain the final SAR wording.

Section 3.6.3 will be changed to eliminate the computer memory and printer and replace it with a strip chart recorder.

Section 3.6.3.2, first paragraph, last line, will be changed to read: "this system will detect those effluents which have been released into the reactor stack, and is set to alarm at the limit currently specified in the AFRI Reactor Emergency Plan."

Table 3-3 will be changed for the Stack Gas Monitor Readout to eliminate the "printout in reactor room (Room 3161)".

See attached for proposed version.

6. For facility modifications, specify what testing is to be performed to assure that the systems involved operate in accordance with their design intent.

The new unit will be isotopically calibrated for sodium upon installation and then recalibrated for Argon-41 once the reactor can be operated.

Facility Modification Work Sheet 1

7. Specify associated information.

New drawings are: Attached OTHER XX Drawings will
Not required be provided with new unit.
Drawings will be placed in appropriate files for maintenance,
calibrations and repairs.

Does a drawing need to be sent Logistics? Yes No XX
Are training materials effected? Yes XX No
Will any Logs have to be changed? Yes No XX
Are other procedures effected? Yes XX No

List of items effected:

SAR Section 3.6.3
SAR Section 3.6.3.2
SAR Table 3-3
Operational Procedure 10 STACK GAS MONITOR PROCEDURE
Calibration Procedure C006 Electronic and Isotopic Calibrations
HPP 7-3 Airborne Radioactivity Samplers and Monitors
Operations Manual (under revision)

8. Create an Action Sheet containing a list of associated work specified in items #7, attach a copy, and submit another to the RFD.

Action Sheet: Submitted XX Not Required

Reviewed and approved by RFD *Mh Wj* Date 12 July 95

RRFSC Concurrence *DJK MJC* Date OCT 18 1995

50.59 Analysis Technical Specification Change Not Required

The Technical Specification requirement under section 3.5.1

- b. Gas Stack Monitor. The gas stack monitor (GSM) will sample and measure the gaseous effluent in the building exhaust system.

The current stack gas monitor PIOPS electronics measure Argon 41 and report the information to the control room on a chart recorder and analog meter. The new analog electronics will report the information in the same locations. The stack gas monitor will continue to measure Argon-41 releases as required in section 3.5.1.b of the Technical Specifications, therefore, no change to the Technical Specifications is required.

The current stack gas monitor is composed of a particle filter, a gas chamber beside a NaI detector, a pump, and computer based electronics which monitor the detector. The outputs from the PIOPS electronics operate High, Alert, and Fail lamps, and an alarm bell on the Stack gas monitor, as well as a remote meter and chart recorder in the reactor control room. The PIOPS electronics have other features which are not in use at this time.

The new stack gas monitor will be composed of the same a particle filter, a gas chamber beside the NaI detector, and pump, but the computer based PIOPS electronics which monitor the detector will be replaced with analog electronics. The outputs from the analog based electronics will operate High, Alert, and Fail lamps, and a sonalert alarm on the Stack gas monitor, as well as the remote meter and chart recorder in the reactor control room.

The sensitivity of the stack gas monitor is based on the sensitivity of the detector. Because the same NaI detector will be used in the new system, the sensitivity of the new unit will not change from the old unit.

This change does not increase the consequences of, nor change the types of accidents previously evaluated in the Safety Analysis Report. this change does not reduce the margin of safety as defined in the bases for any Technical Specifications.

PROPOSED CHANGE TO THE SAR FOR THE NEW STACK GAS MONITOR

ORIGINAL VERSION

3.6.3 Stack Monitoring Systems

The stack monitoring systems consist of the stack flow monitor and the stack gas monitor. These systems provide data about the radioactive effluents discharged through the reactor stack. The stack flow monitor measurements are recorded by a strip chart recorder. Stack gas monitor measurements of Ar⁴¹ emissions are stored in computer memory, summed and automatically printed every six hours. At the end of each day of operation the reactor operator is able to verify that no unusual Ar⁴¹ releases are indicated in the computer memory or printouts for that day.

3.6.3.2 Stack Gas Monitoring System

The stack gas monitor (SGM) system is a NaI scintillation detection system which samples exhaust air from the reactor stack. The air is passed through a filter to remove particulates before being analyzed. This system will detect those effluents which have been released into the reactor stack, and report the average Ar⁴¹ concentration at the sample point every six hours on a printout.

The stack gas monitor system is capable of activating alarms at two levels. Additionally, a flashing visual light on the reactor auxiliary instrumentation console in the reactor control room will be illuminated when the stack gas monitoring system pump motor is turned off. The location of the system readouts and alarms are illustrated in Table 3-3. The setpoints for the radiation alarms can be found in the appropriate AFRRRI internal documents.

TABLE 3-3

STACK MONITORING SYSTEMS

| <u>System</u> | <u>Readout</u> | <u>Radiation Alarm</u> |
|------------------------------|--|---|
| Stack Flow Monitoring System | Strip chart recorder in reactor control room | (Not applicable) However, EF5 failure gives audible and visual alarm in reactor control room |
| Stack Gas Monitoring System | Meter in reactor control room and printout in reactor room (Room 3161) | Activates visual alarm in reactor control room |

PROPOSED VERSION

3.6.3 Stack Monitoring Systems

The stack monitoring systems consist of the stack flow monitor and the stack gas monitor. These systems provide data about the radioactive effluents discharged through the reactor stack. The stack flow monitor measurements are recorded by a strip chart recorder. Stack gas monitor measurements of Ar⁴¹ emissions are recorded on a strip chart recorder and can be viewed at the end of each day by an operator to verify that no unusual Ar⁴¹ releases have occurred.

3.6.3.2 Stack Gas Monitoring System

The stack gas monitor (SGM) system is a NaI scintillation detection system which samples exhaust air from the reactor stack. The air is passed through a filter to remove particulates before being analyzed. This system will detect those effluents which have been released into the reactor stack, and is set to alarm at the limit currently specified in the AFRRRI Reactor Emergency Plan.

The stack gas monitor system is capable of activating alarms at two levels. Additionally, a flashing visual light on the reactor auxiliary instrumentation console in the reactor control room will be illuminated when the stack gas monitoring system pump motor is turned off. The location of the system readouts and alarms are illustrated in Table 3-3. The setpoints for the radiation alarms can be found in the appropriate AFRRRI internal documents.

TABLE 3-3

STACK MONITORING SYSTEMS

| <u>System</u> | <u>Readout</u> | <u>Radiation Alarm</u> |
|------------------------------|--|---|
| Stack Flow Monitoring System | Strip chart recorder in reactor control room | (Not applicable) However, EF5 failure gives audible and visual alarm in reactor control room |
| Stack Gas Monitoring System | Meter in reactor control room | Activates visual alarm in reactor control room |

50.59 ACTION SHEET
STACK GAS MONITOR ELECTRONICS CHANGE

| Item Needing Attention | Date Complete |
|--|---------------|
| Change Section 3.6.3 of the SAR | _____ |
| Change Section 3.6.3.2 of the SAR | _____ |
| Change Table 3-3 of the SAR | _____ |
| Modify Operational Procedure 10 | _____ |
| Modify Calibration Procedure C006 | _____ |
| Sections of HPP 7-3 | _____ |
| Change Operations Manual | _____ |
| Calibrate new SGM electronics | _____ |
| File new schematic diagrams in appropriate files | _____ |
| Remove diagrams for old PIOPS electronics from files | _____ |



NMC Model CRM-51M/91, General Description
Page 1

NMC Model CRM-51M/91 Count Rate Meter

NMC's Model CRM-51M/91 microprocessor-controlled count rate meter is provided to serve as the readout/control unit for various NMC monitors. The CRM-51M/91 may be provided in either a rack-mount configuration or a wall-mount configuration, depending on the customers preference and needs.

The standard CRM-51M/91 module has three latching alarms with manual reset function a five decade (10^1 to 10^6 cpm) count rate range. There is a multipurpose analog meter on the front panel that displays the alarm setpoints, the detector high voltage, 3600 cpm test readings, and normal operating count rates in counts per minute (cpm).

The following text describes the general features of the CRM as well as the operation of the front panel switches.

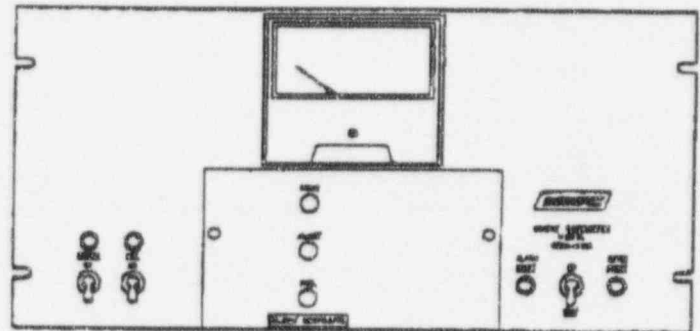

Specifications

| | | | |
|-------------------------------|--|-------------------------------------|--|
| Physical Dimensions: | Width: 19.0 inches, 482.6 mm. Height: 8.75 inches, 223.3 mm. Depth: 11.88 inches, 301.7 mm | Panel Meter Displays: | High Alarm Setpoint Alert Alarm Setpoint Fail Alarm Setpoint |
| Panel Controls: | High Alarm Setpoint Alert Alarm Setpoint Instrument Fail Setpoint Check Source (Optional) Alarm Reset Meter Reset 3600 Test/Operate High Voltage On Power On | Panel Displays: | HV ON (Red) Power On (Green) |
| Card Mask Adjustments: | High Setpoint Fail Setpoint Alert Setpoint High Voltage | Resolution Loss: | Less than 1% at 10^7 CPM |
| | | Power Requirements: | 120 VAC, 60 Hz, 20 Watts. |
| | | High Voltage Range: | 300 to 1,300 volts DC |
| | | Counting Range: | 10^1 to 10^6 counts per minute (Standard) |
| | | Operating Temperature Range: | 0°C to 50°C |



NMC Model CRM-51M/91, General Description
Page 2

Front Panel Controls

Meter Displays: The normal meter display is active in the range of 10^1 to 10^6 counts per minute (cpm). Alternate meter functions are the display of alarm setpoints and the high voltage applied to the detector.

Alarm Levels: The CRM-51M/91 has three alarms. They are: 1) High (or High-High) Radiation Alarm, which is actuated when the detected count rate exceeds the user-established High Alarm setpoint; 2) Alert (or High) Radiation Alarm, which is actuated when the detected count rate exceeds the user-established Alert Alarm setpoint; and 3) Instrument Fail (or Low) Alarm, which is actuated when the detected count rate falls below the user-established Instrument Fail Alarm setpoint.

If an alarm condition is encountered, the appropriate alarm circuit will latch in the alarm state, and a relay will change state. The circuit must be manually reset by pressing the Reset button on the front panel of the CRM.

To display a setpoint, press the HIGH, ALERT, or FAIL Alarm Setpoint push button on the front panel. The setpoint value will be displayed on the meter. The setpoint can be adjusted via potentiometer on the card mask access next to the setpoint buttons.

3600 Test: The 3600 TEST indication switch permits a quick check of the ratemeter calibration. When calibrated the ratemeter will read 3600 cpm $\pm 15\%$.

Check Source: When the CHECK SOURCE-IN switch (Optional) is depressed, a voltage is applied to activate (insert) the check source on the corresponding monitor. When the CHECK SOURCE-IN switch is released, a second voltage is applied to de-energize (retract) the check source. The check source energize and de-energize voltages are factory set depending on the application.

Meter Reset: The METER RESET push button is used to speed up the down scale meter needle movement by setting the meter to zero.

High Voltage Adjust: A potentiometer on the High Voltage Card Mask provides high voltage adjustment from 300 volts to 1,300 volts DC $\pm 5\%$.

High Voltage On Switch: The HI VOLT-ON switch is located on the CRM front panel. Switching on this switch turns on the high voltage to the detector and illuminates a green light above this switch.

Power On Switch: The POWER-ON switch is located on the CRM front panel. Switching on this switch turns on power to the unit.

Optional Features

Analog Outputs: The CRM is equipped to contain up to three analog outputs that are logarithmically related to the input count rate. The analog outputs can be used as recorder outputs to existing customer-supplied equipment. The first is a 0-5V output option built into the CRM-51M/91. The other two buffered analog output signal options include any combination of: 0-1mA, 4-20mA, 10-50mA, 0-10mV, 0-100mV, 0-1V and 0-10V.

Relays: Each CRM drives three DPDT 5 Ampere relays, installed on the AA-13A/91 card, which provide customer access to the alarm circuits. These relays are driven by the High Radiation, Alert Radiation and Instrument Fail alarms. The relays can be configured to be energized or de-energized in the non-alarm state, and either latching or non-latching.

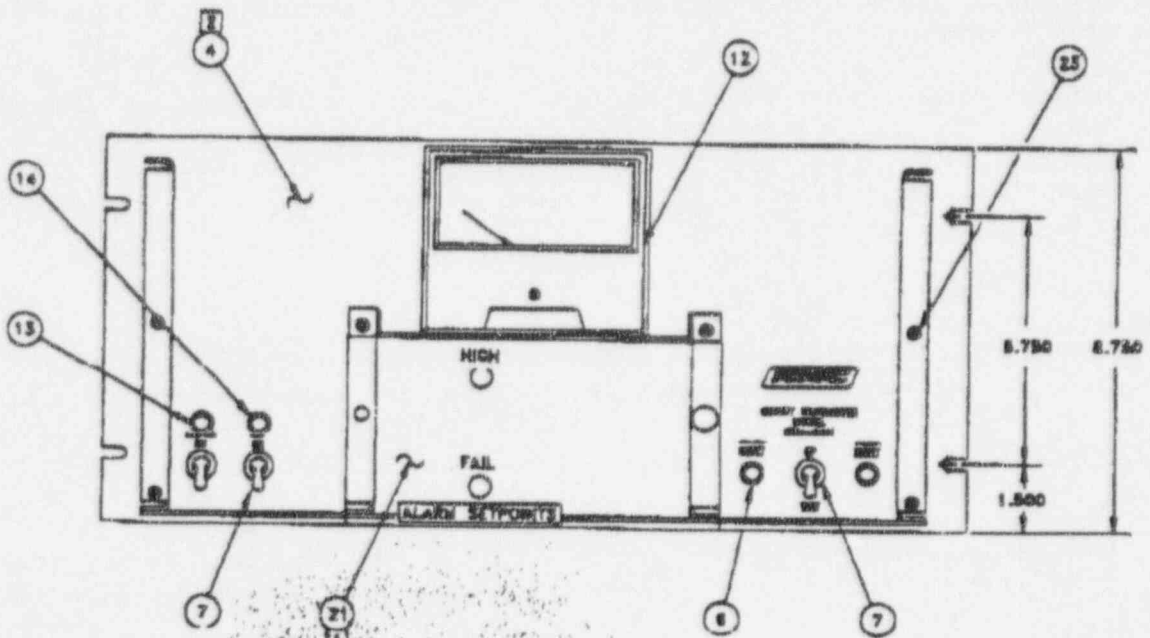
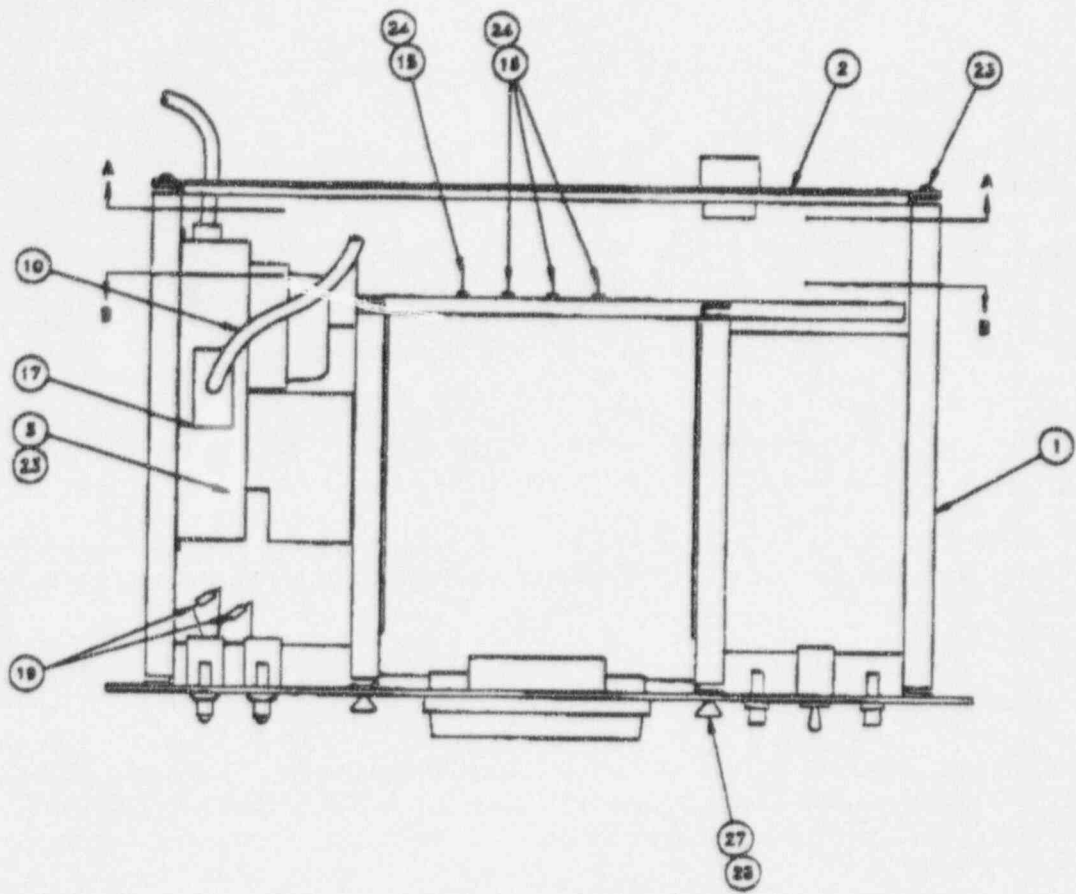

Facility Modification Worksheet 2

No 10 CFR 50.59 Analysis Required

Proposed Change: **Procedure Change- Operational Procedure 8, TAB B**

Modification to: Procedure **X** Facility Experiment

Submitted by: John T. Nguyen Date: **14 July 95**

1. Description of change:

Add (*) symbol to indicate a numeric entry required. Add a phrase "Backup operating" in section V.5 to update the current procedure. Delete items not required, "3152" in section I.4 and "Primary and Backup" in section V.5.

2. The proposed change does not involve a change to the Technical Specifications, the facility as described in the SAR, or procedures as described in the SAR, and does not produce an unresolved safety issue as defined in 10 CFR 50.59(a)(2).

3. If change involves a facility modification, attach a drawing if appropriate. If structural facility drawings need updating, forward a copy of changes necessary to Logistics. **Not Required**

4. Determine what other procedures, logs, or training material may be affected and record below. **see #5**

5. List of associated drawings, procedures, logs, or other materials to be changed:

Operational Procedure 8, TAB B

DAILY OPERATIONAL STARTUP CHECKLIST

Add "*" to section I.1; III.1,2,4,5; V.1,2,4,5; VI.5,8a,9,12.

Add "(b) Backup operating" to section V.5

Delete "3152" to section I.4 and "Primary and Backup" in V.5

6. Create an Action Sheet containing the list of associated work specified above, attach a copy, and submit it to the RFD.

Action Sheet: Submitted Not Required **X**

Reviewed and approved by RFD *Mark Mowley* Date 14 July 95
RRFSC Notified *[Signature]* Date OCT 18 1995

DAILY SAFETY CHECKLIST

Checklist number _____
 Time completed _____

Date _____
 Supervised by _____
 Assisted by _____

I. EQUIPMENT ROOM (Room 3152)

- 1. Air compressor pressure (80 - 110 psig) _____ *
- 2. Water drained from air compressor _____
- 3. Air dryer operating _____
- 4. Doors 231,231A, and roof hatch SECURED _____

II. EQUIPMENT ROOM (Room 2158)

- 1. Prefilter differential pressure (< 8 psid) _____ *
- 2. Primary discharge pressure (15 - 25 psig) _____ *
- 3. Demineralizer flow rates set to 6 gpm (5.5 - 6.5 gpm) _____ *
- 4. Stack roughing filter (notify supervisor if > 1.0" of water) _____ *
- 5. Stack absolute filter (notify supervisor if > 1.35" of water) _____ *
- 6. Visual inspection of area _____
- 7. Door 2158 SECURED _____

III. PREPARATION AREA

Visual inspection of area _____

IV. REACTOR ROOM (Room 3161)

- 1. Transient rod air pressure (78 - 82 psig) _____ *
- 2. Shield door bearing air pressure (8.5 - 9.5 psig) _____ *
- 3. Visual inspection of core and tank _____
- 4. Number of fuel elements and control rods in tank storage
 Fuel elements _____ *
- Control rods _____ *
- 5. Air particulate monitor (CAM)
 - (a) Primary operating and tracing _____
 - (b) Backup operating _____
 - (c) Channel test completed, damper closure verified _____
- 6. Stack gas monitor quality assurance checked _____
- 7. Door 3162 SECURED _____

* Numerical Entry

V. LOBBY AREA

Lobby audio alarm turned off _____

VI. REACTOR CONTROL ROOM (Room 3160)

1. Emergency air dampers reset _____
2. Console recorders dated _____
3. Stack flow and fuel temperature recorders dated _____
4. Logbook dated and reviewed _____
5. Water monitor box
 - (a) Background activity (10 - 60 cpm) *
 - (b) Water monitor box resistivity [> 0.2 Mohm-cm] *
 - (c) DM1 resistivity [> 0.5 Mohm-cm] *
 - (d) DM2 resistivity [> 0.5 Mohm-cm] *
6. Stack gas flow rate [15 - 35 Kcfm] *
7. Stack linear flow rate (1.0 - 2.0 Kft/min) *
8. Gas stack monitor
 - (a) Background (2 - 20 cpm) *
 - (b) Alarm check _____
 - (c) High alarm set to 3.2E-5 microCi/cc at stack top _____
9. Radiation monitors

| Monitor | Alarm Point Functional | Reading (mrem/hr) | Alarm Setting (mrem/hr) |
|---------|---------------------------|----------------------|----------------------------|
| (a) R-1 | _____ | (<20) _____ * | _____ 20 |
| (b) R-2 | _____ | (<10) _____ * | _____ 10 |
| (c) R-3 | _____ | (<10) _____ * | _____ 10 |
| (d) R-5 | _____ | (<20) _____ * | _____ 20 |
| (e) E-3 | _____ | (<10) _____ * | _____ 10 |
| (f) E-6 | _____ | (<10) _____ * | _____ 10 |
10. TV monitors on _____
11. CAM high level audible alarm check _____
12. Water temperature (inlet) (5 -35 °C) *
13. Water level log completed _____
14. Source level power greater/equal to 0.5 cps. _____

Facility Modification Worksheet 2

No 10 CFR 50.59 Analysis Required

Proposed Change: **Procedure Change- Operational Procedure 8, TAB I**

Modification to: Procedure **X** Facility Experiment

Submitted by: John T. Nguyen Date: **14 July 95**

1. Description of change:

Add (*) symbol to indicate a numerical entry required and add a phrase "Warm storage doors closed" .

2. The proposed change does not involve a change to the Technical Specifications, the facility as described in the SAR, or procedures as described in the SAR, and does not produce an unresolved safety issue as defined in 10 CFR 50.59(a)(2).

3. If change involves a facility modification, attach a drawing if appropriate. If structural facility drawings need updating, forward a copy of changes necessary to Logistics. **Not Required**

4. Determine what other procedures, logs, or training material may be affected and record below. **see #5**

5. List of associated drawings, procedures, logs, or other materials to be changed:

Operational Procedure 8, TAB I

DAILY OPERATIONAL SHUTDOWN CHECKLIST

Add "*" to section III.1; VI.8

Add "Warm storage doors closed" to section IV

6. Create an Action Sheet containing the list of associated work specified above, attach a copy, and submit it to the RFD.

Action Sheet: Submitted Not Required **X**

Reviewed and approved by RFD

ML King Date 14 July 95

RRFSC Notified

DJ King Date OCT 18 1995

DAILY OPERATIONAL SHUTDOWN CHECKLIST

Checklist No. _____
Time Completed _____

Date _____
Supervised by _____
Assisted by _____

I. REACTOR ROOM (Room 3161)

- 1. All rod drives DOWN
2. Carriage lights OFF
3. Door 3162 SECURED
4. Channel test completed on both CAMs
5. Door 3161 locked with key

II. EQUIPMENT ROOM (Room 3152)

- 1. Distillation unit discharge valve CLOSED
2. Air dryer OPERATIONAL
3. Doors 231, 231A, and roof hatch SECURED

III. EQUIPMENT ROOM (Room 2158)

- 1. Primary discharge pressure (15 - 25 psig)
2. Demineralizer flow rates set to (5.5 - 6.5 gpm)
3. Visual inspection for leaks
4. Door 2158 SECURED

IV. PREPARATION AREA

- 1. ER 2 plug door CONTROL LOCKED
Door closed; and handwheel PADLOCKED
2. ER 2 lights ON and rheostat at 10%
3. ER 1 plug door CONTROL LOCKED
Door closed; and handwheel PADLOCKED
4. ER 1 lights ON and rheostat at 10%
5. Visual inspection of area
6. Warm storage doors closed

V. LOBBY ALARM

| | |
|----------------------------|--|
| Lobby alarm audio ON | |
|----------------------------|--|

VI. REACTOR CONTROL ROOM (Room 3160)

| | |
|--|--|
| 1. Reactor tank lights OFF | |
| 2. Console chart recorder pens raised | |
| 3. Steady-state timer OFF | |
| 4. Console LOCKED, and all required keys returned to lock box | |
| 5. Diffuser pumps OFF | |
| 6. Purification, secondary and primary pumps ON | |
| 7. Reactor monthly usage summary completed | |
| 8. Radiation monitors | |

| MONITOR | READING | * | HIGH LEVEL ALARM SETTING (mrem/hr) |
|---------|--------------|---|---------------------------------------|
| a. R-1 | (<20) _____ | * | 20 _____ |
| b. R-2 | (< 10) _____ | * | 10 _____ |
| c. R-3 | (<10) _____ | * | 10 _____ |
| d. R-5 | (<20) _____ | * | 20 _____ |
| e. E-3 | (<10) _____ | * | 10 _____ |
| f. E-6 | (<10) _____ | * | 10 _____ |
| g. R-6 | (<10) _____ | * | 10 _____ |

* Numerical Entry

Facility Modification Worksheet 2

No 10 CFR 50.59 Analysis Required

Proposed Change. **Procedure Change- Operational Procedure 8, TAB B1**

Modification to: Procedure **X** Facility Experiment

Submitted by: John T. Nguyen Date: **14 July 95**

1. Description of change:

Add (*) symbol to indicate a numeric entry required. Add a phrase "Backup operating" in section IV.5 to update the current procedure. Delete items not required, "3152" in section I.4 and "Primary and Backup" in section V.4.

2. The proposed change does not involve a change to the Technical Specifications, the facility as described in the SAR, or procedures as described in the SAR, and does not produce an unresolved safety issue as defined in 10 CFR 50.59(a)(2).

3. If change involves a facility modification, attach a drawing if appropriate. If structural facility drawings need updating, forward a copy of changes necessary to Logistics. **Not Required**

4. Determine what other procedures, logs, or training material may be affected and record below. **see #5**

5. List of associated drawings, procedures, logs, or other materials to be changed:

Operational Procedure 8, TAB B1

DAILY SAFETY CHECKLIST

Add "*" to section I.1; II.1,2,4,5; IV.1,2,4,5; VI.5,8a,9,12.

Add "(b) Backup operating" to section IV.5

Delete "3152" to section I.4 and "Primary and Backup" in IV.5

6. Create an Action Sheet containing the list of associated work specified above, attach a copy, and submit it to the RFD.

Action Sheet: Submitted Not Required **X**

Reviewed and approved by RFD *Michael...* Date 14 July 95

RRF&C Notified *Ray...* Date OCT 18 1995

DAILY OPERATIONAL STARTUP CHECKLIST

Checklist number _____
 Time completed _____

Date _____
 Supervised by _____
 Assisted by _____

I. EQUIPMENT ROOM (Room 3152)

- | | | |
|--|-------|---|
| 1. Air compressor pressure (80 - 110 psig) | _____ | * |
| 2. Water drained from air compressor | _____ | |
| 3. Air dryer operating | _____ | |
| 4. Doors 231,231A, and roof hatch SECURED | _____ | |

II. LOBBY AREA

| | |
|------------------------------------|-------|
| Lobby audio alarm turned off | _____ |
|------------------------------------|-------|

III. EQUIPMENT ROOM (Room 2158)

- | | | |
|--|-------|---|
| 1. Prefilter differential pressure (< 8 psid) | _____ | * |
| 2. Primary discharge pressure (15 - 25 psig) | _____ | * |
| 3. Demineralizer flow rates set to 6 gpm (5.5 -6.5 gpm) | _____ | * |
| 4. Stack roughing filter (notify supervisor if > 1.0" of water) | _____ | * |
| 5. Stack absolute filter (notify supervisor if > 1.35" of water) | _____ | * |
| 6. Visual inspection of area | _____ | |
| 7. Door 2158 SECURED | _____ | |

IV. PREPARATION AREA

| | |
|---------------------------------|-------|
| Visual inspection of area | _____ |
|---------------------------------|-------|

V. REACTOR ROOM (Room 3161)

- | | | |
|---|-------|---|
| 1. Transient rod air pressure (78 - 82 psig) | _____ | * |
| 2. Shield door bearing air pressure (8.5 - 9.5 psig) | _____ | * |
| 3. Visual inspection of core and tank | _____ | |
| 4. Number of fuel elements and control rods in tank storage | _____ | * |
| Fuel elements | _____ | * |
| Control rods | _____ | * |
| 5. Air particulate monitor (CAM) | | |
| (a) Primary operating and tracing | _____ | |
| (b) Backup operating | _____ | |
| (c) Channel test completed, damper closure verified | _____ | |
| 6. Stack gas monitor quality assurance checked | _____ | |
| 7. Door 3162 SECURED | _____ | |

* Numerical Entry

VI. REACTOR CONTROL ROOM (Room 3160)

1. Emergency air dampers reset _____
2. Console recorders dated _____
3. Stack flow and fuel temperature recorders dated _____
4. Logbook dated and reviewed _____
5. Water monitor box
 - (a) Background activity (10 - 60 cpm) _____ *
 - (b) Water monitor box resistivity [> 0.2 Mohm-cm] _____ *
 - (c) DM1 resistivity [> 0.5 Mohm-cm] _____ *
 - (d) DM2 resistivity [> 0.5 Mohm-cm] _____ *
6. Stack gas flow rate [15 - 35 Kcfm] _____ *
7. Stack linear flow rate (1.0 - 2.0 Kft/min) _____ *
8. Gas stack monitor
 - (a) Background (2 - 20 cpm) _____ *
 - (b) Alarm check _____
 - (c) High alarm set to 3.2E-5 microCi/cc at stack top _____
9. Radiation monitors

| Monitor | Alarm Point Functional | Reading (mrem/hr) | Alarm Setting (mrem/hr) |
|---------|---------------------------|----------------------|----------------------------|
| (a) R-1 | _____ | (<20) _____ * | _____ 500 |
| (b) R-2 | _____ | (<10) _____ * | _____ 10 |
| (c) R-3 | _____ | (<10) _____ * | _____ 10 |
| (d) R-5 | _____ | (<20) _____ * | _____ 100 |
| (e) E-3 | _____ | (<10) _____ * | _____ 10 |
| (f) E-6 | _____ | (<10) _____ * | _____ 10 |
10. TV monitors on _____
11. CAM high level audible alarm check _____
12. Water temperature (inlet) (5 - 35 °C) _____ *
13. Water level log completed _____
14. Console lamp test completed _____
15. Time delay operative _____
16. Source level power greater/equal to 0.5 cps. _____
17. Prestart operability checks performed _____
18. Interlock Tests

| | | | |
|-----------------------------|-------|---------------------|-------|
| a) Rod raising, SS mode | _____ | (e) 1 kW/Pulse mode | _____ |
| (b) Rod raising, Pulse mode | _____ | (f) NM-1000 HV | _____ |
| (c) Source RWP | _____ | (g) Inlet Temp | _____ |
| (d) Period RWP | _____ | | |
19. SCRAM checks (at least one per rod)

| | | | |
|-----------------|-------|--------------------|-------|
| (a) % Power 1 | _____ | (h) Reactor key | _____ |
| (b) % Power 2 | _____ | (i) Manual | _____ |
| (c) Fuel temp 1 | _____ | (j) Emergency Stop | _____ |
| (d) Fuel temp 2 | _____ | (k) Timer | _____ |
| (e) HV loss 1 | _____ | (l) CSC Watchdog | _____ |
| (f) HV loss 2 | _____ | (m) DAC Watchdog | _____ |
| (g) Pool level | _____ | | |
20. Zero power pulse _____

Facility Modification Worksheet 2

No 10 CFR 50.59 Analysis Required

Proposed Change _____
Procedure 11, "Air Particulate Monitor (CAM) Procedure

Modification to: Procedure x Facility _____ Experiment _____

Submitted by: SFC Danny K. McClung Date 8 Aug 95

1. Description of change:

Procedure 11 is changed to reflect new parameters for channel test on primary and secondary CAM. This is due to installation of new electronics module in primary CAM. Secondary CAM electronics module was changed in May 95. New channel test reading is 1000 cpm +/- 20%. Both CAMs still perform in the same manner.

2. Verify that the proposed change does not involve a change to the Technical Specifications, the facility as described in the SAR, or procedures as described in the SAR, and does not produce an unresolved safety question as defined in 10 CFR 50.59(a)(2). *Done*

3. If change involves a facility modification, attach a drawing if appropriate. If structural facility drawings need updating, modification of drawings must be approved by RFD and forward a copy of changes necessary to Logistics. *N/A*

4. Determine what other procedures, logs, or training material may be affected and record below. *None*

5. List of associated drawings, procedures, logs, or other materials to be changed:
None

6. Create an Action Sheet containing the list of associated work specified above, attach a copy, and submit it to the RFD.

Action Sheet: Submitted _____ Not Required x

Reviewed and approved by RFD *[Signature]* Date 09 AUG 1995

RRFSC Notified *[Signature]* Date OCT 18 1995

AIR PARTICULATE MONITOR(CAM) PROCEDURE

GENERAL

This procedure specifies how to test the CAM to ensure proper operation of this monitoring device. A channel test will be performed on both reactor room CAMs at the beginning and end of each day.

SPECIFIC

1. OPERATING and TRACING

Check that the primary CAM is operating and tracing with the correct time indicated on the chart and check that the secondary CAM is operating. Ensure the flow rate is >6 cfm and not off scale.

2. CHANNEL TEST WITH SOURCE

- a. Place the switch on the front of the CAM to "test" and verify a reading of 1000 cpm $\pm 20\%$. Reset the switch.
- b. Open shield door and change the detector filter if the filter appears excessively dirty or the flow rate has dropped below 6 cfm (with the door closed). Place the used filter in the radioactive waste box in each CAM drawer.
- c. Slowly bring a radioactive source near the detector. Observe the meter on the front of the CAM. The yellow light will activate at approximately 4,000 counts per minute. The red light will activate at approximately 10,000 counts per minute; the alarm will sound and the dampers will close. Reset the alarm, close the chamber door and return the source to the CAM drawer.
- d. Annotate completion of the channel test on chart paper with initials, time, and date performed for primary CAM. Annotate completion of the channel test on secondary CAM chart paper only when primary CAM is bypassed.

3. TEST FREQUENCY

This entire procedure will be performed in conjunction with the daily startup or safety checklist. Items 1, 2a and 2d will be performed again as part of the daily shutdown checklist.

4. BY-PASS of PRIMARY CAM

When the primary CAM is by-passed, the secondary CAM chart recorder needs to be activated, then perform items 1, 2a, and 2d.

Facility Modification Worksheet 2

No 10 CFR 50.59 Analysis Required

Proposed Change: **Procedure Change- Operational Procedure A3**

Modification to: Procedure **X** Facility Experiment

Submitted by: John T. Nguyen Date: **09 Aug 95**

1. Description of change:

In page 2, Par 3 a word, "following", is changed to "followed by".

2. The proposed change does not involve a change to the Technical Specifications, the facility as described in the SAR, or procedures as described in the SAR, and does not produce an unresolved safety issue as defined in 10 CFR 50.59(a)(2).

3. If change involves a facility modification, attach a drawing if appropriate. If structural facility drawings need updating, forward a copy of changes necessary to Logistics. **Not Required**

4. Determine what other procedures, logs, or training material may be affected and record below. **see # 5**

5. List of associated drawings, procedures, logs, or other materials to be changed:

Operational Procedure A3, Facility Modification

In page 2, Paragraph 3 a word, "following", is changed to "followed by".

6. Create an Action Sheet containing the list of associated work specified above, attach a copy, and submit it to the RFD.

Action Sheet: Submitted Not Required **X**

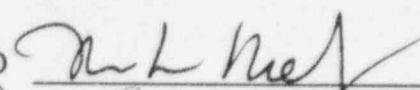
Reviewed and approved by RFD  Date **09 AUG 1995**

RRFSC Notified  Date **OCT 18 1995**

FACILITY MODIFICATION

GENERAL

Changes to the Reactor Facility and operational procedures must comply with requirements specified in the Reactor License, and 10 CFR 50.59. It is required that modifications to the facility or procedures as described in the Safety Analysis Report (SAR) be documented with a written safety analysis. Under 10 CFR 50.59, a licensee may make changes to the facility provided there are no changes made to the Technical Specifications, there are no unreviewed safety questions, and that a proper safety analysis is carried out, documented, and reviewed.

Applicability:

- The Facility Modification Procedure applies to proposed facility changes or changes in the operating procedures.
- The referenced procedure will not cover routine replacement of parts or components with equivalent parts or components.

DESCRIPTION

This administrative procedure consists of these instructions, the Facility Modification Worksheet Guide, and two worksheets to facilitate a 10 CFR 50.59 review of modifications and to determine if a detailed safety analysis is necessary. The instructions in the Facility Modification Worksheet Guide are used to determine which worksheet must be completed for the modification. One of three conclusions regarding the proposed facility modification will be reached:

1. The modification requires prior approval or a license amendment from the USNRC,
2. The modification may be made according to the provisions of 10 CFR 50.59(a)(1) (Facility Modification Worksheet # 1), or
3. The modification does not require a 10 CFR 50.59 safety analysis (Facility Modification Worksheet # 2).

Facility Modification Worksheet Guide

1. **Technical Specification Change:** If the proposed modification requires a change in the Technical Specifications, a license amendment is required prior to making the change. NRC approval is required; do not implement the change without this approval.
2. **Unreviewed Safety Question:** If an unreviewed safety question is created by the proposed change as defined in 10 CFR 50.59(a)(2) such that the change increases the probability of occurrence or severity of an accident described in the SAR, can malfunction in a manner that can cause an accident of a different type than described in the SAR or can decrease safety margins as defined in Technical Specifications, then NRC approval is required. Do not implement the change without this approval.
3. If the proposed modification makes a change in the facility as described in the SAR or changes a procedure as described in the SAR, the change can be performed under a 10 CFR 50.59 analysis with a safety review, if there are no unreviewed safety issues (10 CFR 50.59(a)(2)). The change may be made followed by a review by the RRFSC. Go to Facility Modification Worksheet # 1.
4. If the proposed modification does not make a change to the facility as described in the SAR or to a procedure as described in the SAR and does not pose an unreviewed safety issue, a 10 CFR 50.59 analysis is not required. Go to Facility Modification Worksheet # 2.

Facility Modification Worksheet 1

10 CFR 50.59 Analysis

Proposed Change _____

Submitted by: _____ Date _____

1. Description of change:

2 Reason for change:

3. Verify that the proposed change does not involve a change to the Technical Specifications or produce an unresolved safety issue as specified in 10 CFR 50.59(a)(2). Attach an analysis to show this.

Analysis attached? Yes _____

4. The proposed modification constitutes a changes in the facility or an operational procedure as described in the SAR. Describe which (check all that apply).

Procedure _____ Facility _____ Experiment _____

Facility Modification Worksheet 1

5. Specify what sections of the SAR are applicable. In general terms describe the necessary updates to the SAR. Note that this description need not contain the final SAR wording.

6. For facility modifications, specify what testing is to be performed to assure that the systems involved operate in accordance with their design intent.

Facility Modification Worksheet 1

7. Specify associated information.

New drawings are: Attached
Not required

Does a drawing need to be sent to Logistics? Yes No
Are training materials effected? Yes No
Will any Logs have to be changed? Yes No
Are other procedures effected? Yes No

List of items affected:

8. Create an Action Sheet containing a list of associated work specified in item # 7, attach a copy, and submit another to the RFD (modification of drawings must be approved by the RFD).

Action Sheet: Submitted Not Required

Reviewed and approved by RFD _____ Date _____

RRFSC Concurrence _____ Date _____

Facility Modification Worksheet 2

No 10 CFR 50.59 Analysis Required

Proposed Change _____

Modification to: Procedure _____ Facility _____ Experiment _____

Submitted by: _____ Date _____

1. Description of change:

2. Verify that the proposed change does not involve a change to the Technical Specifications, the facility as described in the SAR, or procedures as described in the SAR, and does not produce an unresolved safety question as defined in 10 CFR 50.59(a)(2).

3. If change involves a facility modification, attach a drawing if appropriate. If structural facility drawings need updating, modification of drawings must be approved by RFD and forward a copy of changes necessary to Logistics.

4. Determine what other procedures, logs, or training material may be affected and record below.

5. List of associated drawings, procedures, logs, or other materials to be changed:

6. Create an Action Sheet containing the list of associated work specified above, attach a copy, and submit it to the RFD

Action Sheet: Submitted _____ Not Required _____

Reviewed and approved by RFD _____ Date _____

RRFSC Notified _____ Date _____

ATTACHMENT C

**Appointment Letters for Current Reactor
and Radiation Facility Safety Committee
Charges**



RRFSC

ARMED FORCES RADIOBIOLOGY RESEARCH INSTITUTE

8901 WISCONSIN AVENUE
BETHESDA, MARYLAND 20889-5603

FILE

18 September 1995
605.01

MEMORANDUM FOR RECORD

SUBJECT: Members of Reactor and Radiation Facility Safety Committee

Effective this date, the following individuals are members of the Armed Forces Radiobiology Research Institute (AFRRI) Reactor and Radiation Facility Safety Committee (RRFSC). Memberships are in accordance with the Technical Specifications of Nuclear Regulatory Commission license R-84.

PERMANENT MEMBERS

| | |
|--|---------------|
| Thomas J. O'Brien, AFRRI, Radiation Safety Officer | Voting Member |
| Mark Moore, AFRRI, Reactor Facility Director | Voting Member |

APPOINTED MEMBERS

| | |
|--|---------------|
| David G. Jarrett, COL, MC, USA, AFRRI, Chairman | Voting Member |
| Dr. Marcus Voth, The Pennsylvania State University, Reactor Facility Director | Voting Member |
| Mark A. Miller, Naval Research Laboratories, Radiation Safety Officer | Voting Member |

SPECIAL MEMBERS

| | |
|--|---------------------------|
| Charles B. Galley, CAPT, MSC, USN, AFRRI, Head, Radiation Sciences Department | Special Voting Member |
| James Caldwell, Montgomery County Government, Environmental Protection Department | Special Non-Voting Member |
| Dr. Leslie McKinney, AFRRI, Radiation Pathophysiology and Toxicology Department | Special Non-Voting Member |

RECORDER

| | |
|-----------------------------------|---------------------------|
| Danny K. McClung, SFC, USA, AFRRI | Special Non-Voting Member |
|-----------------------------------|---------------------------|

E. KEARSLEY
CAPT, MSC, USN
Director

DISTRIBUTION:
1-each individual
1-RRFSC file

RSDR

31 January 1995

MEMORANDUM FOR DIR
THROUGH RFD
COS *421/104*

SUBJECT: Additional Duty Appointment

Request that SFC Danny K. McClung be appointed as Recorder (non-voting member) for the Reactor and Radiation Facility Safety Committee.

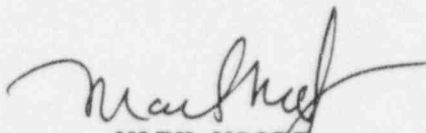

MARK MOORE
Reactor Facility Director

Concur/Nonconcur

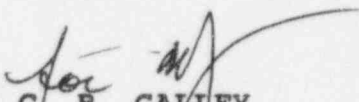

C. B. GALLEY
Captain, MSC, USN
Head, Radiation Sources Department

Concur/Nonconcur

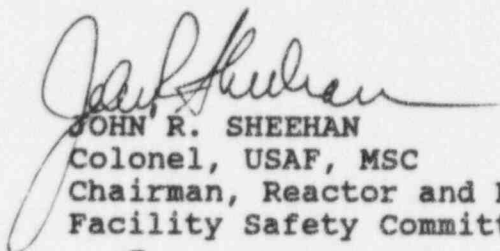

JOHN R. SHEEHAN
Colonel, USAF, MSC
Chairman, Reactor and Radiation
Facility Safety Committee

Approved/Disapproved

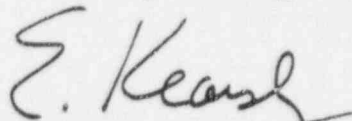

ERIC E. KEARSLEY
Captain, MSC, USN
Acting Director

CC:
SFC McClung
RRFSC File

RRFSC

23 February 1995

MEMORANDUM FOR RECORD

SUBJECT: Appointment of Alternate Member, RRFSC

Mr. Steve Miller is appointed as an alternate member for the 1 March 1995 RRFSC meeting. The Reactor Facility Director is unavailable due to travel commitments. Mr. Miller's knowledge and position qualify him to substitute.

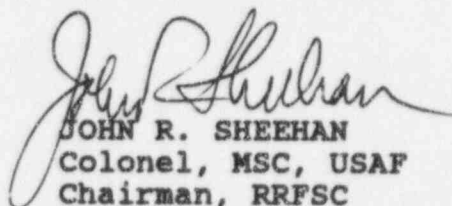
JOHN R. SHEEHAN
Colonel, MSC, USAF
Chairman, RRFSC

DISTRIBUTION:
1-Mr. Miller
1-RRFSC file

DIR

18 September 1995

MEMORANDUM FOR RECORD

SUBJECT: Reactor and Radiation Facility Safety Committee Special
Members

Effective this date, the appointment of the following special
member to the RRFSC is rescinded:

Eric G. Daxon, LTC(P), MSC, USA.

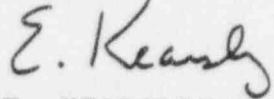

E. KEARSLEY
CAPT, MSC, USN
Director

DIR

18 September 1995

MEMORANDUM FOR RECORD

SUBJECT: Reactor and Radiation Facility Safety Committee Special
Members

Effective this date the appointment of the following member to
the RRFSC is rescinded:

Mr. Kirk King, Naval Research Laboratory.

Mr. King is replaced by Mr. Mark A. Miller, also of Naval
Research Laboratory. Mr. Miller's expertise in the field of
radiation protection qualifies him to be a voting member of the
RRFSC.



E. KEARSLEY
CAPT, MSC, USN
Director

ATTACHMENT D

Summary of all Maintenance for 1995

ATTACHMENT E

Fresh Water Use In Pump House

**TRIGA TRACKER
MAINTENANCE ANNUAL
REPORT**

1995

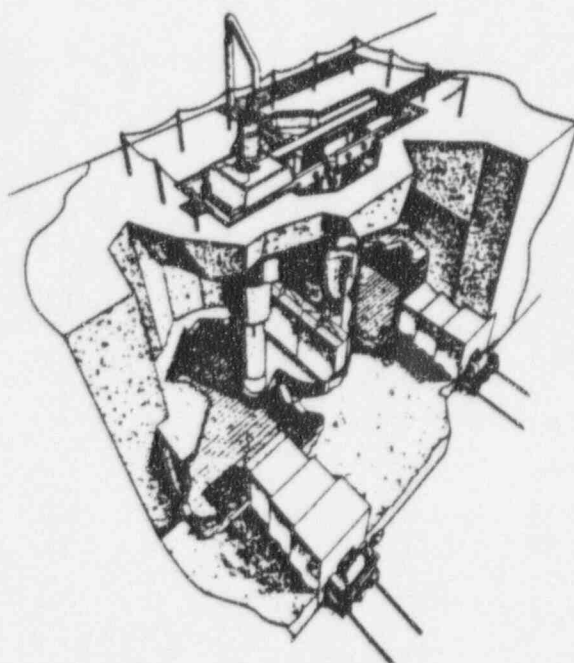

Armed Forces Radiobiology Research Institute
8901 Wisconsin Avenue
Bethesda, Maryland 20889-5603

AFRRI/RSD

Date 22 JAN 1996

MEMORANDUM FOR Reactor Facility Director
 Deputy Reactor Facility Director
 Reactor Operator Supervisor
 Record

SUBJECT: Maintenance Annual Report -1995

The Son of TRIGA Tracker provides the reactor staff information concerning maintenance tasks, frequency, requirement, due date, and date of completion. All information is stored in a database which is updated throughout the year as maintenance is performed. The following is the summary of the Maintenance Annual Report for 1995:

1. The following tasks have not completed:

| ID_Nu m | Task | Requirement | Due Date |
|------------|---|-----------------------|-----------|
| A019 | Security Personnel Training This task is also postponed until Feb 96 | Emergency Plan 8.1 | 16-DEC-95 |

2. 306 items were performed during the year

Attached is the maintenance report which provided a list of completed tasks in 1995. Notice that this report is sorted by task ID number and date of completion. Please review, initial and return to me for filing.

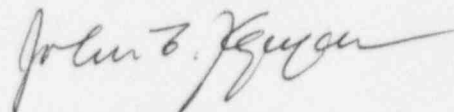

John T. Nguyen

Abbreviation

The following are the abbreviations used in the Annual Maintenance Report

ID_NUM

A =Administrative

C =Calibration

M =Maintenance

P =Reportable

S =Surveillance

TASKS

RRFSC =Reactor & Radiation Facility Safety Committee

ERT =Emergency Response Team

SNM =Special Nuclear Material

SCBA =Self Contained Breathing Apparatus

RWP =Rod Withdrawal Prevent

RAM =Remote Area Monitor

RTD =Resistance Temperature Detector

CSC =Control System Computer

DAC =Data Acquisition Computer

REQUIREMENT

TS =Technical Specifications

CFR =Code of Federal Regulations

EP =Emergency Plan

OP =Operational Procedure

Req =Requalification

NRC =Nuclear Regulatory Commission

Internal =Not required except by internal Facility Director Memorandum

PSP =Physical Security Plan

Manual =Manufacture's recommendation in maintenance manual

ASC =Annual Shutdown Checklist

FREQUENCY

M =Monthly

Q =Quarterly

S =Semi-Annually

A =Annually

N =Non-routine

SON of TRIGA TRACKER MAINTENANCE ANNUAL REPORT - 1995

| ID_NUM | TASKS | REQUIREMENT | FREQUENCY | LAST_DONE |
|--------|--|------------------------|-----------|-----------|
| A001 | RRFSC Meeting, Full or Subcommittee | TS 6.2.3.2 | Q | 01-MAR-95 |
| A001 | RRFSC Meeting, Full or Subcommittee | TS 6.2.3.2 | Q | 02-JUN-95 |
| A001 | RRFSC Meeting, Full or Subcommittee | TS 6.2.3.2 | Q | 18-OCT-95 |
| A001 | RRFSC Meeting, Full or Subcommittee | TS 6.2.3.2 | Q | 18-DEC-95 |
| A002 | Emergency Directions Memorandum | Internal | Q | 01-JAN-95 |
| A002 | Emergency Directions Memorandum | Internal | Q | 01-APR-95 |
| A002 | Emergency Directions Memorandum | Internal | Q | 01-JUL-95 |
| A002 | Emergency Directions Memorandum | Internal | Q | 02-OCT-95 |
| A004 | On-Call Designation Memorandum | TS 6.1.3.2 | Q | 01-JAN-95 |
| A004 | On-Call Designation Memorandum | TS 6.1.3.2 | Q | 01-APR-95 |
| A004 | On-Call Designation Memorandum | TS 6.1.3.2 | Q | 01-JUL-95 |
| A004 | On-Call Designation Memorandum | TS 6.1.3.2 | Q | 02-OCT-95 |
| A005 | Reactor Access Roster | PSP | Q | 01-JAN-95 |
| A005 | Reactor Access Roster | PSP | Q | 01-APR-95 |
| A005 | Reactor Access Roster | PSP | Q | 01-JUL-95 |
| A005 | Reactor Access Roster | PSP | Q | 02-OCT-95 |
| A006 | Operator Records Review | 10 CFR 55, Requal Plan | Q | 03-JAN-95 |
| A006 | Operator Records Review | 10 CFR 55, Requal Plan | Q | 03-APR-95 |
| A006 | Operator Records Review | 10 CFR 55, Requal Plan | Q | 03-JUL-95 |
| A006 | Operator Records Review | 10 CFR 55, Requal Plan | Q | 30-OCT-95 |
| A007 | Emergency Training of ECP Personnel | EP 8.1 | A | 09-NOV-95 |
| A008 | Emergency Drill | EP 8.2; 10 CFR 50 | A | 29-NOV-95 |
| A009 | ERT Training | EP 8.1 | Q | 22-FEB-95 |
| A009 | ERT Training | EP 8.1 | Q | 22-MAR-95 |
| A009 | ERT Training | EP 8.1 | Q | 21-JUN-95 |
| A009 | ERT Training | EP 8.1 | Q | 27-SEP-95 |
| A009 | ERT Training | EP 8.1 | Q | 29-NOV-95 |
| A010 | Prep Area Access Memo Review/Update | OP A2 | A | 04-JAN-96 |
| A011 | Reactor Facility Audit | TS 6.2.5 | A | 26-OCT-95 |
| A012 | Emergency Plan Review | 10 CFR 50, EP 8.3 | A | 16-JAN-96 |
| A013 | Accountability Report for SNM | 10 CFR 73 | S | 31-MAR-95 |
| A013 | Accountability Report for SNM | 10 CFR 73 | S | 02-OCT-95 |
| A014 | Emergency Briefing for AFRRRI Personnel | EP 8.1(3) | A | 05-DEC-94 |
| | Note: This task is late and postponed until Feb 96 | | | |
| A015 | Reactor Operations Logbook Review | OP 8, TAB A | N | 26-OCT-95 |
| A016 | NNMC Security & Fire Personnel Training | EP 8.1 | A | 23-MAR-95 |
| A017 | Publish Schedule for Requal Lectures | 10 CFR 55.59 | A | 18-JAN-96 |
| A018 | Physical Security Plan Review | Security Plan 6a | A | 19-DEC-95 |

SON of TRIGA TRACKER MAINTENANCE ANNUAL REPORT - 1995

| ID_NUM | TASKS | REQUIREMENT | FREQUENCY | LAST_DONE |
|--------|---|-------------------------|-----------|-----------|
| A019 | Security Personnel Training Note: This task is late and postponed until Feb 96 | EP 8.1 | A | 16-DEC-94 |
| A023 | Wallet Size Recall Roster | TS 6.1.3.2 | N | 06-JAN-95 |
| A024 | SCBA Training for ERT Members | 10 CFR 20.1703 | A | 15-MAR-95 |
| A025 | Officer of the Day Annual Training | AFRRI Inst 5200.8A | A | 28-JUL-95 |
| A026 | Training for Prep Area Users | 10 CFR 19.12 | A | 12-APR-95 |
| A027 | RRFSC Minutes and Summary of Action | Internal | Q | 14-JAN-95 |
| A027 | RRFSC Minutes and Summary of Action | Internal | Q | 26-APR-95 |
| A027 | RRFSC Minutes and Summary of Action | Internal | Q | 26-JUL-95 |
| A027 | RRFSC Minutes and Summary of Action | Internal | Q | 25-OCT-95 |
| A027 | RRFSC Minutes and Summary of Action | Internal | Q | 28-DEC-95 |
| C001 | Calibration of Cooling System Gauges | Internal | A | 28-APR-95 |
| C002 | Calibrate Pressure Gauges/ Air System | Internal | A | 30-OCT-95 |
| C004 | Fuel Temp Channel I Calibration | TS 4.2.3b | A | 05-OCT-95 |
| C005 | Fuel Temp Channel II Calibration | TS 4.2.3b | A | 05-OCT-95 |
| C006 | Stack Gas Monitor Calibration | Manual | A | 04-OCT-95 |
| C007 | Operational Channel Calibration | TS 4.2.2c | A | 06-OCT-95 |
| C008 | Safety Channel I Calibration | TS 4.2.2c | A | 05-OCT-95 |
| C009 | Safety Channel II Calibration | TS 4.2.2c | A | 06-OCT-95 |
| C010 | Scram Circuit Calibration | TS 3.2.2 | A | 29-NOV-95 |
| C011 | RWP Calibration | TS 3.2.2 | A | 29-NOV-95 |
| C012 | Control Rod Calibration | TS 3.1.2 & 4.1a | A | 07-DEC-95 |
| C013 | Criticality Monitor, Elec Calibration | TS 4.5 | A | 12-DEC-95 |
| C014 | RAM System Calibration | TS 4.5 | A | 12-DEC-95 |
| C015 | Thermal Power Calibration | TS 4.2.2c | A | 01-NOV-95 |
| C016 | Fuel Temp Chart Recorder Calibration | TS 4.2.3b, 2.1 | A | 05-OCT-95 |
| C017 | Fuel Temp Prestart Action Pak Cal | Manual, Annual Shutdown | A | 05-OCT-95 |
| C018 | Magnet Power Supply Action Pak Cal | Manual, Annual Shutdown | A | 05-OCT-95 |
| C019 | Ground Fault Detector Action Pak Cal | Manual, Annual Shutdown | A | 05-OCT-95 |

SON of TRIGA TRACKER MAINTENANCE ANNUAL REPORT - 1995

| ID_NUM | TASKS | REQUIREMENT | FREQUENCY | LAST_DONE |
|--------|--|-------------------------|-----------|-----------|
| C020 | AI016 Boards Calibration | Manual, Annual Shutdown | A | 05-OCT-95 |
| C021 | Thermocouple Quality Assurance Verificat | Manual, Annual Shutdown | A | 05-OCT-95 |
| C022 | RTD Probes Calibration | Internal | A | 24-OCT-95 |
| C023 | Calibration of Pulse Ion Chamber | TS 3.2.1 & 4.2.2 | A | 02-NOV-95 |
| C024 | Calibration of Cerenkov Detector | TS 3.2.1 & 4.2.2 | A | 02-NOV-95 |
| M001 | UPS System Test for Criticality Monitor | 10 CFR 70 | M | 27-JAN-95 |
| M001 | UPS System Test for Criticality Monitor | 10 CFR 70 | M | 23-FEB-95 |
| M001 | UPS System Test for Criticality Monitor | 10 CFR 70 | M | 29-MAR-95 |
| M001 | UPS System Test for Criticality Monitor | 10 CFR 70 | M | 21-APR-95 |
| M001 | UPS System Test for Criticality Monitor | 10 CFR 70 | M | 26-MAY-95 |
| M001 | UPS System Test for Criticality Monitor | 10 CFR 70 | M | 26-JUN-95 |
| M001 | UPS System Test for Criticality Monitor | 10 CFR 70 | M | 28-JUL-95 |
| M001 | UPS System Test for Criticality Monitor | 10 CFR 70 | M | 30-AUG-95 |
| M001 | UPS System Test for Criticality Monitor | 10 CFR 70 | M | 29-SEP-95 |
| M001 | UPS System Test for Criticality Monitor | 10 CFR 70 | M | 23-OCT-95 |
| M001 | UPS System Test for Criticality Monitor | 10 CFR 70 | M | 28-NOV-95 |
| M001 | UPS System Test for Criticality Monitor | 10 CFR 70 | M | 28-DEC-95 |
| M002 | Stack Gas Monitor Oil Check | Manual | M | 27-JAN-95 |
| M002 | Stack Gas Monitor Oil Check | Manual | M | 23-FEB-95 |
| M002 | Stack Gas Monitor Oil Check | Manual | M | 28-MAR-95 |
| M002 | Stack Gas Monitor Oil Check | Manual | M | 21-APR-95 |
| M002 | Stack Gas Monitor Oil Check | Manual | M | 26-MAY-95 |
| M002 | Stack Gas Monitor Oil Check | Manual | M | 26-JUN-95 |
| M002 | Stack Gas Monitor Oil Check | Manual | M | 28-JUL-95 |
| M002 | Stack Gas Monitor Oil Check | Manual | M | 30-AUG-95 |
| M002 | Stack Gas Monitor Oil Check | Manual | M | 29-SEP-95 |
| M002 | Stack Gas Monitor Oil Check | Manual | M | 27-OCT-95 |
| M002 | Stack Gas Monitor Oil Check | Manual | M | 28-NOV-95 |
| M002 | Stack Gas Monitor Oil Check | Manual | M | 28-DEC-95 |
| M003 | Transient Rod Air System | Manual | M | 30-JAN-95 |
| M003 | Transient Rod Air System | Manual | M | 27-FEB-95 |
| M003 | Transient Rod Air System | Manual | M | 28-MAR-95 |
| M003 | Transient Rod Air System | Manual | M | 21-APR-95 |
| M003 | Transient Rod Air System | Manual | M | 26-MAY-95 |
| M003 | Transient Rod Air System | Manual | M | 26-JUN-95 |
| M003 | Transient Rod Air System | Manual | M | 28-JUL-95 |
| M003 | Transient Rod Air System | Manual | M | 30-AUG-95 |
| M003 | Transient Rod Air System | Manual | M | 29-SEP-95 |
| M003 | Transient Rod Air System | Manual | M | 01-NOV-95 |
| M003 | Transient Rod Air System | Manual | M | 28-NOV-95 |
| M003 | Transient Rod Air System | Manual | M | 28-DEC-95 |
| M004 | Air Damper Operation & SCBA check | TS 3.4 & 4.4 & 5.1c | M | 27-JAN-95 |
| M004 | Air Damper Operation & SCBA check | TS 3.4 & 4.4 & 5.1c | M | 23-FEB-95 |
| M004 | Air Damper Operation & SCBA check | TS 3.4 & 4.4 & 5.1c | M | 29-MAR-95 |
| M004 | Air Damper Operation & SCBA check | TS 3.4 & 4.4 & 5.1c | M | 21-APR-95 |
| M004 | Air Damper Operation & SCBA check | TS 3.4 & 4.4 & 5.1c | M | 30-MAY-95 |

SON of TRIGA TRACKER MAINTENANCE ANNUAL REPORT - 1995

| ID_NUM | TASKS | REQUIREMENT | FREQUENCY | LAST_DONE |
|--------|---|---------------------|-----------|-----------|
| M004 | Air Damper Operation & SCBA check | TS 3.4 & 4.4 & 5.1c | M | 26-JUN-95 |
| M004 | Air Damper Operation & SCBA check | TS 3.4 & 4.4 & 5.1c | M | 28-JUL-95 |
| M004 | Air Damper Operation & SCBA check | TS 3.4 & 4.4 & 5.1c | M | 30-AUG-95 |
| M004 | Air Damper Operation & SCBA check | TS 3.4 & 4.4 & 5.1c | M | 29-SEP-95 |
| M004 | Air Damper Operation & SCBA check | TS 3.4 & 4.4 & 5.1c | M | 27-OCT-95 |
| M004 | Air Damper Operation & SCBA check | TS 3.4 & 4.4 & 5.1c | M | 28-NOV-95 |
| M004 | Air Damper Operation & SCBA check | TS 3.4 & 4.4 & 5.1c | M | 28-DEC-95 |
| M005 | Millipore Water Makeup System | Manual | M | 27-JAN-95 |
| M005 | Millipore Water Makeup System | Manual | M | 23-FEB-95 |
| M005 | Millipore Water Makeup System | Manual | M | 28-MAR-95 |
| M005 | Millipore Water Makeup System | Manual | M | 21-APR-95 |
| M005 | Millipore Water Makeup System | Manual | M | 26-MAY-95 |
| M005 | Millipore Water Makeup System | Manual | M | 26-JUN-95 |
| M005 | Millipore Water Makeup System | Manual | M | 28-JUL-95 |
| M005 | Millipore Water Makeup System | Manual | M | 30-AUG-95 |
| M005 | Millipore Water Makeup System | Manual | M | 29-SEP-95 |
| M005 | Millipore Water Makeup System | Manual | M | 31-OCT-95 |
| M005 | Millipore Water Makeup System | Manual | M | 28-NOV-95 |
| M005 | Millipore Water Makeup System | Manual | M | 28-DEC-95 |
| M006 | Lube Pump & Bearings of Prim. Cooling | Manual | M | 27-JAN-95 |
| M006 | Lube Pump & Bearings of Prim. Cooling | Manual | M | 23-FEB-95 |
| M006 | Lube Pump & Bearings of Prim. Cooling | Manual | M | 28-MAR-95 |
| M006 | Lube Pump & Bearings of Prim. Cooling | Manual | M | 21-APR-95 |
| M006 | Lube Pump & Bearings of Prim. Cooling | Manual | M | 30-MAY-95 |
| M006 | Lube Pump & Bearings of Prim. Cooling | Manual | M | 26-JUN-95 |
| M006 | Lube Pump & Bearings of Prim. Cooling | Manual | M | 28-JUL-95 |
| M006 | Lube Pump & Bearings of Prim. Cooling | Manual | M | 30-AUG-95 |
| M006 | Lube Pump & Bearings of Prim. Cooling | Manual | M | 29-SEP-95 |
| M006 | Lube Pump & Bearings of Prim. Cooling | Manual | M | 27-OCT-95 |
| M006 | Lube Pump & Bearings of Prim. Cooling | Manual | M | 28-NOV-95 |
| M006 | Lube Pump & Bearings of Prim. Cooling | Manual | M | 28-DEC-95 |
| M007 | Lube Pump & Motor bearings, 2nd cooling | Manual | M | 27-JAN-95 |
| M007 | Lube Pump & Motor bearings, 2nd cooling | Manual | M | 23-FEB-95 |
| M007 | Lube Pump & Motor bearings, 2nd cooling | Manual | M | 28-MAR-95 |
| M007 | Lube Pump & Motor bearings, 2nd cooling | Manual | M | 21-APR-95 |
| M007 | Lube Pump & Motor bearings, 2nd cooling | Manual | M | 30-MAY-95 |
| M007 | Lube Pump & Motor bearings, 2nd cooling | Manual | M | 26-JUN-95 |
| M007 | Lube Pump & Motor bearings, 2nd cooling | Manual | M | 28-JUL-95 |
| M007 | Lube Pump & Motor bearings, 2nd cooling | Manual | M | 30-AUG-95 |
| M007 | Lube Pump & Motor bearings, 2nd cooling | Manual | M | 29-SEP-95 |
| M007 | Lube Pump & Motor bearings, 2nd cooling | Manual | M | 27-OCT-95 |
| M007 | Lube Pump & Motor bearings, 2nd cooling | Manual | M | 28-NOV-95 |
| M007 | Lube Pump & Motor bearings, 2nd cooling | Manual | M | 28-DEC-95 |
| M008 | Experimental Tables and Stands | Internal | Q | 29-MAR-95 |
| M008 | Experimental Tables and Stands | Internal | Q | 29-JUN-95 |
| M008 | Experimental Tables and Stands | Internal | Q | 05-OCT-95 |
| M008 | Experimental Tables and Stands | Internal | Q | 12-DEC-95 |
| M009 | Channel Test of Criticality Monitor | 10 CFR 70 | Q | 09-MAR-95 |
| M009 | Channel Test of Criticality Monitor | TS 4.5, 10 CFR 70 | Q | 21-JUN-95 |

SON of TRIGA TRACKER MAINTENANCE ANNUAL REPORT - 1995

| ID_NUM | TASKS | REQUIREMENT | FREQUENCY | LAST_DONE |
|--------|---|-------------------|-----------|-----------|
| M009 | Channel Test of Criticality Monitor | TS 4.5, 10 CFR 70 | Q | 28-SEP-95 |
| M009 | Channel Test of Criticality Monitor | TS 4.5, 10 CFR 70 | Q | 12-DEC-95 |
| M010 | Channel Test of RAM | TS 4.5, 10 CFR 70 | Q | 09-MAR-95 |
| M010 | Channel Test of RAM | TS 4.5, 10 CFR 70 | Q | 21-JUN-95 |
| M010 | Channel Test of RAM | TS 4.5, 10 CFR 70 | Q | 28-SEP-95 |
| M010 | Channel Test of RAM | TS 4.5, 10 CFR 70 | Q | 12-DEC-95 |
| M011 | Clutch Adjustment Check of Shield Doors | Manual | Q | 27-JAN-94 |
| M011 | Clutch Adjustment Check of Shield Doors | Manual | Q | 21-APR-95 |
| M011 | Clutch Adjustment Check of Shield Doors | Manual | Q | 28-JUL-95 |
| M011 | Clutch Adjustment Check of Shield Doors | Manual | Q | 23-OCT-95 |
| M012 | Pressure Relief Dampers Inspection | Internal | Q | 30-MAR-95 |
| M012 | Pressure Relief Dampers Inspection | Internal | Q | 26-JUN-95 |
| M012 | Pressure Relief Dampers Inspection | Internal | Q | 28-SEP-95 |
| M012 | Pressure Relief Dampers Inspection | Internal | Q | 05-JAN-96 |
| M013 | Lamp, Filter Check on Storage Tank | Manual | Q | 27-JAN-95 |
| M013 | Lamp, Filter Check on Storage Tank | Manual | Q | 21-APR-95 |
| M013 | Lamp, Filter Check on Storage Tank | Manual | Q | 28-JUL-95 |
| M013 | Lamp, Filter Check on Storage Tank | Manual | Q | 01-NOV-95 |
| M014 | Exercise Reactor Water Syst Valves | Internal | M | 27-JAN-95 |
| M014 | Exercise Reactor Water Syst Valves | Internal | M | 23-FEB-95 |
| M014 | Exercise Reactor Water Syst Valves | Internal | M | 31-MAR-95 |
| M014 | Exercise Reactor Water Syst Valves | Internal | M | 21-APR-95 |
| M014 | Exercise Reactor Water Syst Valves | Internal | M | 30-MAY-95 |
| M014 | Exercise Reactor Water Syst Valves | Internal | M | 26-JUN-95 |
| M014 | Exercise Reactor Water Syst Valves | Internal | M | 28-JUL-95 |
| M014 | Exercise Reactor Water Syst Valves | Internal | M | 30-AUG-95 |
| M014 | Exercise Reactor Water Syst Valves | Internal | M | 29-SEP-95 |
| M014 | Exercise Reactor Water Syst Valves | Internal | M | 27-OCT-95 |
| M014 | Exercise Reactor Water Syst Valves | Internal | M | 28-NOV-95 |
| M014 | Exercise Reactor Water Syst Valves | Internal | M | 28-DEC-95 |
| M015 | Cooling Tower Inspection | Internal | S | 29-JUN-95 |
| M015 | Cooling Tower Inspection | Internal | S | 05-JAN-96 |
| M016 | Change Stack Gas Blower Oil | Manual | Q | 28-MAR-95 |
| M016 | Change Stack Gas Blower Oil | Manual | Q | 29-JUN-95 |
| M016 | Change Stack Gas Blower Oil | Manual | Q | 04-OCT-95 |
| M016 | Change Stack Gas Blower Oil | Manual | Q | 22-JAN-96 |
| M017 | Reg, Safe & Shim Rod Drive, Check Belts | Internal | Q | 31-MAR-95 |
| M017 | Reg, Safe & Shim Rod Drive, Check Belts | Internal | Q | 26-JUN-95 |
| M017 | Reg, Safe & Shim Rod Drive, Check Belts | Internal | Q | 19-OCT-95 |
| M017 | Reg, Safe & Shim Rod Drive, Check Belts | Internal | Q | 22-JAN-96 |
| M018 | Grease Wheel Bearings in ER1 | Manual | Q | 30-JAN-95 |
| M018 | Grease Wheel Bearings in ER1 | Manual | Q | 01-MAY-95 |
| M018 | Grease Wheel Bearings in ER1 | Manual | Q | 31-JUL-95 |
| M018 | Grease Wheel Bearings in ER1 | Manual | Q | 30-OCT-95 |

SON of TRIGA TRACKER MAINTENANCE ANNUAL REPORT - 1995

| ID_NUM | TASKS | REQUIREMENT | FREQUENCY | LAST_DONE |
|--------|--|-------------------------|-----------|-----------|
| M019 | Grease Wheel Bearings in ER2 | Manual | Q | 30-JAN-95 |
| M019 | Grease Wheel Bearings in ER2 | Manual | Q | 01-MAY-95 |
| M019 | Grease Wheel Bearings in ER2 | Manual | Q | 31-JUL-95 |
| M019 | Grease Wheel Bearings in ER2 | Manual | Q | 30-OCT-95 |
| M020 | Change Air Compressor Oil | Manual | Q | 28-MAR-95 |
| M020 | Change Air Compressor Oil | Manual | Q | 26-JUN-95 |
| M020 | Change Air Compressor Oil | Manual | ? | 04-OCT-95 |
| M020 | Change Air Compressor Oil | Manual | Q | 22-JAN-96 |
| M021 | Control Rods Visual Inspection | TS 4.1c & 4.2.5 | A | 27-OCT-95 |
| M022 | Control Rod Examination | TS 4.1c & 4.2.5 | A | 27-OCT-95 |
| M023 | Rod Drive Installation | Manual, Annual Shutdown | A | 30-OCT-95 |
| M024 | Control Rod Connecting Pins | Internal | M | 27-JAN-95 |
| M024 | Control Rod Connecting Pins | Internal | M | 27-FEB-95 |
| M024 | Control Rod Connecting Pins | Internal | M | 31-MAR-95 |
| M024 | Control Rod Connecting Pins | Internal | M | 21-APR-95 |
| M024 | Control Rod Connecting Pins | Internal | M | 31-MAY-95 |
| M024 | Control Rod Connecting Pins | Internal | M | 26-JUN-95 |
| M024 | Control Rod Connecting Pins | Internal | M | 28-JUL-95 |
| M024 | Control Rod Connecting Pins | Internal | M | 30-AUG-95 |
| M024 | Control Rod Connecting Pins | Internal | M | 29-SEP-95 |
| M024 | Control Rod Connecting Pins | Internal | M | 27-OCT-95 |
| M024 | Control Rod Connecting Pins | Internal | M | 05-DEC-95 |
| M024 | Control Rod Connecting Pins | Internal | M | 05-JAN-96 |
| M025 | Oil Level Check in Lead Shield Door Syst | Manual | A | 23-OCT-95 |
| M026 | Inspect Seals around Reactor Room Doors | Internal | S | 30-MAR-95 |
| M026 | Inspect Seals around Reactor Room Doors | Internal | S | 29-SEP-95 |
| M027 | Still Inspection & Cleaning | Manual | A | 23-OCT-95 |
| M028 | Console Chart Recorder Inspection | Internal | A | 23-OCT-95 |
| M029 | Reg Rod Drive Annual Maintenance | Manual | A | 19-OCT-95 |
| M030 | Safe Rod Drive Annual Maintenance | Manual | A | 19-OCT-95 |
| M031 | Shim Rod Drive Annual Maintenance | Manual | A | 19-OCT-95 |
| M032 | Trans Rod Drive Annual Maintenance | Manual | A | 21-AUG-95 |
| M033 | Facility Interlock Checklist | TS 4.2.4 & 3.2.3 | S | 18-APR-95 |
| M033 | Facility Interlock Checklist | TS 4.2.4 & 3.2.3 | S | 01-DEC-95 |
| M034 | Timer Cleaning & Inspection | Manual | A | 23-OCT-95 |
| M035 | Standard Rod Drive Removal | TS 2.1 & 4.2.5 | A | 19-OCT-95 |

SON of TRIGA TRACKER MAINTENANCE ANNUAL REPORT - 1995

| ID_NUM | TASKS | REQUIREMENT | FREQUENCY | LAST_DONE |
|--------|--|-------------------------|-----------|-----------|
| M036 | Transient Rod Drive Inspection | TS 4.1d | S | 31-MAR-95 |
| M036 | Transient Rod Drive Inspection | TS 4.1d | S | 21-SEP-95 |
| M037 | Digital Rod Position Indicators Adjust | Internal | A | 30-OCT-95 |
| M038 | Rod Drive Barrel Removal | Manual, Annual Shutdown | A | 19-OCT-95 |
| M040 | Rod Drive Barrel Assembly | Manual, Annual Shutdown | A | 30-OCT-95 |
| M041 | Change Absolute, Roughing & Prefilter | Manual | N | 17-JAN-95 |
| M042 | Change Resin Beds on still | Internal | N | 11-JAN-95 |
| M044 | Change Demineralizer Resins | Internal | N | 18-AUG-95 |
| M045 | Core Dolly Oil Check | Manual | A | 23-OCT-95 |
| M047 | CSC & DAC Computer Filter Cleaning | Manual | Q | 27-FEB-95 |
| M047 | CSC & DAC Computer Filter Cleaning | Manual | Q | 31-MAY-95 |
| M047 | CSC & DAC Computer Filter Cleaning | Manual | Q | 31-AUG-95 |
| M047 | CSC & DAC Computer Filter Cleaning | Manual | Q | 15-DEC-95 |
| M048 | Am-Be Neutron Source Check | NRC Byproduct License | A | 24-MAR-95 |
| P001 | Verification of Reactor Monthly Usage | OP 8 | M | 31-JAN-95 |
| P001 | Verification of Reactor Monthly Usage | OP 8 | M | 28-FEB-95 |
| P001 | Verification of Reactor Monthly Usage | OP 8 | M | 31-MAR-95 |
| P001 | Verification of Reactor Monthly Usage | OP 8 | M | 28-APR-95 |
| P001 | Verification of Reactor Monthly Usage | OP 8 | M | 01-JUN-95 |
| P001 | Verification of Reactor Monthly Usage | OP 8 | M | 30-JUN-95 |
| P001 | Verification of Reactor Monthly Usage | OP 8 | M | 31-JUL-95 |
| P001 | Verification of Reactor Monthly Usage | OP 8 | M | 01-SEP-95 |
| P001 | Verification of Reactor Monthly Usage | OP 8 | M | 02-OCT-95 |
| P001 | Verification of Reactor Monthly Usage | OP 8 | M | 01-NOV-95 |
| P001 | Verification of Reactor Monthly Usage | OP 8 | M | 30-NOV-95 |
| P001 | Verification of Reactor Monthly Usage | OP 8 | M | 02-JAN-96 |
| P002 | Key Inventory | OP 5 | A | 31-JUL-95 |
| P003 | Annual Operating Report | TS 6.6.1b | A | 27-MAR-95 |
| P004 | Indemnity Payment to NRC | 10 CFR 140 | A | 18-APR-95 |
| P005 | Enriched Uranium Lease Agreement | Agreement #1037 | N | 11-DEC-95 |
| S001 | Hall Alarm Panel Operable Verification | EP 8.4 | Q | 10-MAR-95 |
| S001 | Hall Alarm Panel Operable Verification | EP 8.4 | Q | 26-JUN-95 |
| S001 | Hall Alarm Panel Operable Verification | EP 8.4 | Q | 04-OCT-95 |
| S001 | Hall Alarm Panel Operable Verification | EP 8.4 | Q | 22-JAN-96 |
| S002 | Inventory of Emergency Equipment | EP 6.6 | Q | 31-JAN-95 |
| S002 | Inventory of Emergency Equipment | EP 6.6 | Q | 14-APR-95 |
| S002 | Inventory of Emergency Equipment | EP 6.6 | Q | 24-JUL-95 |

SON of TRIGA TRACKER MAINTENANCE ANNUAL REPORT - 1995

| ID_NUM | TASKS | REQUIREMENT | FREQUENCY | LAST_DONE |
|--------|---|---------------------|-----------|-----------|
| S002 | Inventory of Emergency Equipment | EP 6.6 | Q | 23-OCT-95 |
| S003 | Control Rod Drop Times Measurement | TS 4.2.1 & 3.1.4 | S | 11-APR-95 |
| S003 | Control Rod Drop Times Measurement | TS 4.2.1 & 3.1.4 | S | 31-OCT-95 |
| S004 | Reflector Coefficient & Excess Reactivity | TS 4.1a; OP 8 tab D | A | 12-DEC-95 |
| S005 | Reactor Water Analysis for Nitrate | Hach Handbook | A | 03-OCT-95 |
| S007 | SCBA Regulator Annual Flow Test | 10 CFR 20.1703 | A | 22-NOV-95 |
| S008 | Reactor Water Analysis for Iron | Hach Handbook | A | 03-OCT-95 |
| S010 | Fuel Elements Measurement/Inspection | TS 4.2.5 & 5.2.2e | A | 27-OCT-95 |
| S011 | Power Coefficient of Reactivity | TS 4.1f | A | 12-DEC-95 |
| S012 | Load Testing of Reactor Hoist | 29 CFR 1910.179 | A | 09-MAY-95 |
| S013 | Reactor Water Analysis for Nitrite | Hach Handbook | A | 03-OCT-95 |
| S014 | Reactor Water Analysis for Aluminum | Hach Handbook | A | 03-OCT-95 |
| S015 | Reactor Water Analysis for Ammonia | Hach Handbook | M | 27-JAN-95 |
| S015 | Reactor Water Analysis for Ammonia | Hach Handbook | M | 27-FEB-95 |
| S015 | Reactor Water Analysis for Ammonia | Hach Handbook | M | 31-MAR-95 |
| S015 | Reactor Water Analysis for Ammonia | Hach Handbook | M | 21-APR-95 |
| S015 | Reactor Water Analysis for Ammonia | Hach Handbook | M | 05-JUN-95 |
| S015 | Reactor Water Analysis for Ammonia | Hach Handbook | M | 26-JUN-95 |
| S015 | Reactor Water Analysis for Ammonia | Hach Handbook | M | 28-JUL-95 |
| S015 | Reactor Water Analysis for Ammonia | Hach Handbook | M | 30-AUG-95 |
| S015 | Reactor Water Analysis for Ammonia | Hach Handbook | M | 03-OCT-95 |
| S015 | Reactor Water Analysis for Ammonia | Hach Handbook | M | 27-OCT-95 |
| S015 | Reactor Water Analysis for Ammonia | Hach Handbook | M | 04-DEC-95 |
| S015 | Reactor Water Analysis for Ammonia | Hach Handbook | M | 28-DEC-95 |
| S016 | Reactor Water Analysis for Chloride | Hach Handbook | A | 03-OCT-95 |
| S017 | Reactor Water Analysis for Copper | Hach Handbook | A | 03-OCT-95 |

SHD/RSO

4 Aug 95

MEMORANDUM FOR RECORD
THROUGH SHD

SUBJECT: Contractor Use of Fresh Water from Pump House

On 3 Aug 95 I was informed that contractors replacing the steam line in the rear of AFRRI were using the fresh water hose bib from the AFRRI Radiological Waste Facility Pump House. Apparently the lock securing the Pump House door had been broken allowing access. LOGF was immediately contacted and installed another lock to secure the door. I also informed MSG DeMilia and Mark Moore of the event. SHD had given previous permission for contractors to use the fresh water line which was contingent upon their notifying us for access. Apparently, at some point in time the contractors accessed the pump house themselves by breaking the lock.

On 4 Aug 95, MSG DeMilia requested I meet with him and Mr. Tom O'Pray (the NNMC ROICC 295-7748). Mr. O'Pray discussed the construction workers concerns about the "radioactive water" they had been bathing in and drinking for the past 2-3 weeks. I told him that although the fresh water line is in our Radioactive Waste Tank Pump House, it is completely isolated from the radioactive material waste lines and would not contain radioactive water.

I further explained that SHD performs weekly surveys in the Pump House which have always indicated there is no radiological contamination present. I then summarized that the entry of the workers into the Pump House and subsequent use of the water from the fresh water line did not expose anyone to radioactivity and therefore was of no radiological safety concern.

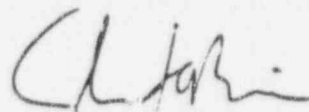

Thomas J. O'Brien
Radiation Safety Officer
Safety and Health Department

ASD

500
02 October 1995

MEMORANDUM FOR DEPUTY DIRECTOR FOR ADMINISTRATION

SUBJECT: Pump House Break-in

I recommend that the Pump House Break-in incident be closed after the final recommendation is approved.

- a. AFRRI personnel shall not allow access to this building to non AFRRI personnel unless approved (in writing) by the Radiation Safety Officer.

Corrective actions have already been accomplished. The contractor was notified of the breaking and entering; however, without proof of who actually committed the crime, we would just be "shooting in the dark" in an attempt to collect damages for \$114.70.

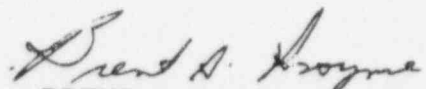
BRENT A. HAYNIE
LCDR (Sel), MSC, USN
Security Officer

Approved/disapproved

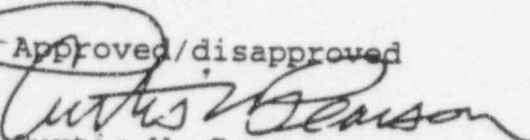
Curtis W. Pearson
Col, USAF, MSC
Deputy Director for Administration

cc:
Head, Safety and Health Department
MSG Demilia