

JM Litch 7/20/84PHILADELPHIA ELECTRIC COMPANY
LIMERICK GENERATING STATION
EMERGENCY PLAN IMPLEMENTING PROCEDUREEP-102 UNUSUAL EVENT RESPONSE1.0 PURPOSE

The purpose of this procedure is to provide guidelines for site response to an Unusual Event.

2.0 RESPONSIBILITIES

- 2.1 Shift Supervision shall assume the role of the Interim Emergency Director when an Unusual Event occurs, unless Emergency Director is present, and perform the necessary steps in this procedure.
- 2.2 The Station Superintendent may assume the role of the Emergency Director and relieve the Interim Emergency Director, if necessary.

3.0 APPENDICES

- 3.1 EP-102-1 Unusual Event Notification Message
- 3.2 EP-102-2 Unusual Event De-Escalation Message
- 3.3 EP-102-3 Unusual Event Phone List

4.0 PREREQUISITES

- 4.1 EP-101, Classification of Emergencies has been completed.

5.0 SPECIAL EQUIPMENT

None

CONTROLLED
VALID ONLY WHEN RED

6.0 SYMPTOMS

None

7.0 ACTION LEVEL

This procedure shall be implemented when an event occurs that is classified as an Unusual Event per procedure EP-101 Classifications of Emergencies.

8.0 PRECAUTIONS

None

9.0 PROCEDURE

9.1 ACTIONS

9.1.1 (Interim) Emergency Director shall:

9.1.1.1 Verify the emergency classification as determined in EP-101, Classification of Emergencies unless determination has just been made.

9.1.1.2 Complete Appendix EP-102-1, Unusual Event Notification Message, and give it to a communicator and direct the communicator to complete notification of the appropriate parties in Appendix EP-102-3, Unusual Event Phone List.

9.1.1.3 Direct Shift Supervision to initiate evacuation of affected areas, as necessary. Refer to the following procedure:

EP-303 Local Evacuation

9.1.1.4 Contact the Station Superintendent, if necessary, and the Shift Technical Advisor, inform them of the situation.

- 9.1.1.5 For samples, contact the Shift Chemistry Technician. If necessary, implement EP-230, Chemistry Sampling and Analysis Team Activation.
- 9.1.1.6 For in-plant surveys, or contaminated injury, contact a Shift HP Technician. If necessary, implement EP-250, Personnel Safety Team Activation.
- 9.1.1.7 For fire/damage repair, contact the Maintenance Shift Assistance Foreman. If necessary, to implement EP-260, Fire and Damage Team Activation and/or EP-261, Damage Repair Group.
- 9.1.1.8 For a liquid release, implement EP-312, Radioactive Liquid Release, if required.
- 9.1.1.9 For security matters, implement EP-208, Security Team Activation, if required.
- 9.1.1.10 For airborne releases, contact Shift Technical Advisor. If necessary, implement EP-210, Dose Assessment Team Activation.

9.2 FOLLOW-UP

- 9.2.1 (Interim) Emergency Director shall:
 - 9.2.1.1 Periodically evaluate the event classification in accordance with EP-101, Classification of Emergencies, and escalate or de-escalate the classification, as necessary.
 - 9.2.1.2 If classification is de-escalated fill out Appendix EP-102-2, Unusual Event De-Escalation Message and give it to the communicator and direct the communicator to perform notification of the appropriate parties listed in Appendix EP-102-3, Unusual Event Phone List.
 - 9.2.1.3 Obtain the following information as necessary to formulate further actions:
 - A. Sample analysis from Shift Chemistry Technician or Chemistry Sampling and Analysis Team Leader.

- B. In-plant surveys or status of contaminated injury from Shift HP Technician or Personnel Safety Team Leader.
- C. Fire/Damage Repair status from the Maintenance Shift Assistant Foreman or Fire and Damage Team Leader.
- D. Airborne releases calculation from Shift Technical Advisor or Dose Assessment Team Leader.
- E. Notification Results from Communicator.

9.2.1.4 Determine which support personnel are necessary for emergency functions and direct the Shift Clerk to contact those personnel. If Shift Clerk is not available, this function shall be assigned to an available individual.

9.2.2 The Communicator Shall:

9.2.2.1 Inform (Interim) Emergency Director when appropriate notifications have been made and submit completed copy of Appendix EP-102-3, Unusual Event Phone List, for (Interim) Emergency Director's Signature.

10. REFERENCES

- 10.1 Limerick Generating Station Emergency Plan
- 10.2 NUREG-0654, Criteria For Preparation and Evaluation of Radiological Emergency Response Plans and Preparedness in Support of Nuclear Power Plants. Rev. 1
- 10.3 EP-303 Local Evacuation
- 10.4 EP-101 Classification of Emergencies
- 10.5 EP-230 Chemistry Sampling and Analysis Team Activation
- 10.6 EP-250 Personnel Safety Team Activation
- 10.7 EP-260 Fire and Damage Team Activation
- 10.8 EP-261 Damage Repair Group
- 10.9 EP-312 Radioactive Liquid Release

APPENDIX EP-102-1

UNUSUAL EVENT NOTIFICATION MESSAGE

MESSAGE: This (is)(is not) a drill. This (is)(is not) a drill.

This is the Limerick Generating Station calling to report an Unusual

Event. My name is _____, telephone

_____. Limerick Generating Station is reporting an

Unusual Event declared at Unit No. _____. Time and date of

Unusual Event classification are

_____,
(24 Hr Clock Time)

_____.
(Date)

The basic problem is _____.

There (has been) (has not been) an (airborne) (liquid) radioactive
release from the plant. The plant status is (stable) (improving)
(degrading) (not known). There is no protective action recommended.

This (is) (is not) a drill. This (is) (is not) a drill.

APPENDIX EP-102-2

UNUSUAL-EVENT DE-ESCALATION MESSAGE

MESSAGE: This (is) (is not) a drill. This (is) (is not) a drill.
This is Limerick Generating Station calling to de-escalate an
Unusual Event. Please connect me with the appropriate authority.
This is Limerick Generating Station calling to report the
termination of an Unusual Event. My name is _____.
Time and date are _____. This (is) (is not) a drill.
This (is) (is not) a drill.

APPENDIX EP-102-3
UNUSUAL EVENT PHONE LIST

Time Initiated	Personnel/Agency To Be Notified	Phone Number	Time	Person Responding
	a. Emergency Director [REDACTED]	Home Office [REDACTED]		
	Alternate [REDACTED]	Home Office [REDACTED]		
	b. [REDACTED]	Office [REDACTED]		
	c. [REDACTED]	[REDACTED]		
	d. [REDACTED]	[REDACTED]		
	e. [REDACTED]	[REDACTED]		
	f. [REDACTED]	Home Office [REDACTED]		
		(after tone, dial phone number which you are using)		
	g. [REDACTED]	Home Office [REDACTED]		

CONFIDENTIAL



PHILADELPHIA ELECTRIC COMPANY
LIMERICK GENERATING STATION
EMERGENCY PLAN IMPLEMENTING PROCEDURE

EP-103 ALERT RESPONSE

1.0 PURPOSE

The purpose of this procedure is to provide guidelines for site response to an Alert.

2.0 RESPONSIBILITIES

- 2.1 Shift Supervision shall assume the role of the Interim Emergency Director when an Alert occurs, unless the Emergency Director is present, and perform the necessary steps in this procedure.
- 2.2 The Station Superintendent or Alternate shall assume the role of the Emergency Director, report to the Technical Support Center or Control Room and relieve the Interim Emergency Director.

3.0 APPENDICES

- 3.1 EP-103-1 Alert Notification Message
- 3.2 EP-103-2 Emergency Exposure Guidelines
- 3.3 EP-103-3 Alert De-Escalation Notification Message
- 3.4 EP-103-4 Alert Phone List (Initial Notification)
- 3.5 EP-103-5 Alert Phone List (Escalation or De-escalation)

4.0 PREREQUISITES

- 4.1 EP-101, Classification of Emergencies, completed

CONTROLLED

VALID ONLY WHEN RED

5.0 SPECIAL EQUIPMENT

None

6.0 SYMPTOMS

None

7.0 ACTION LEVEL

This procedure shall be implemented when an event occurs that is classified as an Alert per procedure EP-101 Classification of Emergencies.

8.0 PRECAUTIONS

8.1 Planned radiation exposures should be limited to the administrative guide levels in Appendix EP-103-2, Emergency Exposure Guidelines.

9.0 PROCEDURE

9.1 ACTIONS

9.1.1 (Interim) Emergency Director shall:

9.1.1.1 Verify the Emergency Classification as determined in EP-101, Classification of Emergencies, unless determination has just been made.

9.1.1.2 Fill out Appendix EP-103-1 Alert Notification Message and give it to the communicator.

9.1.1.3 Direct the communicator to complete notification of the appropriate parties as specified in Appendix EP-103-4, Alert Phone List, (Initial Notification) or Appendix EP-103-5, Alert Phone List (Escalation or De-escalation). The Communicator shall man the NRC RED telephone on a continuous basis until the NRC disconnects. If the communicator is required for urgent plant operations related to the emergency, the concurrence for securing the phone should be obtained from the NRC prior to securing this telephone.

9.1.1.4 Contact the Station Superintendent and the Shift Technical Advisor, inform them of the situation.

9.1.1.5 [REDACTED] to implement EP-306, Evacuation of The Information Center. Inform the Staff of the wind direction if there is an airborne release.

9.1.1.6 If there is a radiological release, implement EP-305, Site Evaluation.

9.1.1.7. If there has not been a radiological release,

A. [REDACTED]
Direct them to call for a "Total Project Evacuation" in accordance with Bechtel procedures.

B. [REDACTED] and inform them that a Total Project Evacuation of Bechtel Construction Personnel is being implemented.

THIS WILL CALL FOR THE ASSEMBLY OF PERSONNEL AT THE UPPER PARKING LOT AND POST #3. IF IT IS DESIRED THAT THEY LEAVE THE SITE, INFORM BECHTEL COMMAND POSTS AT THE UPPER PARKING LOT.

PROPRIETARY

C. Select the type of accountability desired for personnel in the protected area and implement the required actions below:

1. Emergency Assembly Without Accountability

-Make the following announcement

"THIS (IS)(IS NOT) A DRILL. DESIGNATED EMERGENCY PERSONNEL REPORT TO ASSIGNED EMERGENCY RESPONSE FACILITIES. ALL OTHER PERSONNEL STAND BY FOR FURTHER ANNOUNCEMENT. THIS (IS) (IS NOT) A DRILL."

2. Emergency Assembly With Accountability

a. Select Unit 1 exit points as follows:

Day Shift - TSC and Administration Building
Afternoon Shift - Administration Building
Night Shift - Administration Building

b. Contact the (Interim) Security Team Leader. Inform him of the selected exit point(s), that emergency assembly with accountability is going to be implemented, and to activate the Security Team (EP-208) and to perform personnel accountability in accordance with EP-110, Personnel Assembly and Accountability.

c. [REDACTED] and inform them that personnel leaving Unit 1 will be reassembling at the Personnel Processing Center (PPC).

"THIS (IS)(IS NOT) A DRILL, THIS (IS)(IS NOT) A DRILL. DESIGNATED EMERGENCY PERSONNEL REPORT TO ASSIGNED EMERGENCY RESPONSE FACILITIES. ALL OTHER PERSONNEL LEAVE THE PROTECTED AREA IMMEDIATELY THROUGH THE (name of exit area or areas) AND REASSEMBLE AT THE PERSONNEL PROCESSING CENTER. THIS (IS)(IS NOT) A DRILL. THIS (IS)(IS NOT) A DRILL."

PROPRIETARY

- 9.1.1.8 For off-hours, direct the Shift Clerk to activate the call list using EP-291, Staffing Augmentation. If Shift Clerk is not available, this function shall be assigned to any available individual.
- 9.1.1.9 Direct the activation of the Technical Support Center in accordance with EP-201, Technical Support Center (TSC) Activation.
- 9.1.1.10 If necessary, activate the Emergency Operations Facility in accordance with EP-203, Emergency Operations Facility (EOF) Activation.
- 9.1.1.11 Assign an Operations Support Center Coordinator (PO) to direct available personnel to report to the Operations Support Center on 269' Elev. Turbine Bldg. and to activate it in accordance with EP-202, Operations Support Center (OSC) Activation.
- 9.1.1.12 For samples, direct the Shift Chemistry Technician or Chemistry Sampling and Analysis Team Leader to implement EP-230, Chemistry Sampling and Analysis Team Activation.
- 9.1.1.13 For in-plant surveys, direct a Shift HP Technician or Personnel Safety Team Leader to implement EP-250, Personnel Safety Team Activation.
- 9.1.1.14 For field surveys, when a release of gaseous radioactive material has occurred or is suspected, direct the Dose Assessment Team Leader to implement EP-210, Dose Assessment Team Activation.
- 9.1.1.15 For a release at or greater than the Alert level in EP-101, Classification of Emergencies, direct the Dose Assessment Team Leader to implement EP-210, Dose Assessment Team Activation. On an interim bases, direct the Shift Technical Advisor to perform dose projections using EP-316, Cumulative Population Dose Calculations For Airborne Releases - Manual Method or RMMS Computer and implement EP-317, Determination of Protective Action Recommendations.

- 9.1.1.16 For fire/damage repair direct the Maintenance Shift Assistant Foreman or Fire and Damage Team Leader to implement EP-260, Fire and Damage Team Activation and/or EP-261, Damage Repair Group.
- 9.1.1.17 For a liquid release, implement EP-312 Radioactive Liquid Release, if required.
- 9.1.1.18 For Security matters, contact Security Shift Supervision and direct implementation of EP-208, Security Team Activation, unless previously done.

9.2 FOLLOW-UP

- 9.2.1 (Interim) Emergency Director shall:
 - 9.2.1.1 Verify that the Technical Support Center, the Emergency Operations Facility (if necessary) and the Operations Support Center have been activated.
 - 9.2.1.2 Periodically evaluate the event classification in accordance with EP-101, Classification of Emergencies and maintain, escalate or de-escalate the classification, as necessary.
 - 9.2.1.3 If classification is de-escalated, fill out Appendix EP-103-3, Alert De-Escalation Notification Message and give it to the communicator and direct the communicator to perform notification of the appropriate parties listed in Appendix EP-103-5, Alert Phone List (Escalation or De-escalation).
 - 9.2.1.4 Obtain the following information as necessary to formulate further actions:
 - A. Security status from Security Team Leader
 - B. Sample analysis from Shift Chemist or Chemistry Sampling and Analysis Team Leader
 - C. In-plant surveys from Shift HP Technician or Personnel Safety Team Leader

- D. Field surveys from Dose Assessment Team Leader
 - E. Dose projections and protective action recommendations from Shift Technical Advisor or Dose Assessment Team Leader
 - F. Fire/damage repair status from the Maintenance Shift Assistant Foreman or Fire and Damage Team Leader
 - G. Notification results from Communicator
- 9.2.1.5 Determine which additional support personnel are necessary for emergency functions and direct the Shift Clerk or other assigned communicator in TSC to contact those personnel.
 - 9.2.1.6 Provide site personnel with public address (PA) announcements for any major changes in plant emergency status, such as changing emergency action levels and evacuations.
 - 9.2.1.7 Evaluate the need and order evacuation of effected areas as necessary. Refer to the following procedures: EP-303 Local Evacuation, EP-304 Partial Plant Evacuation, EP-305 Site Evacuation.
 - 9.2.2 The Communicator shall:
 - 9.2.2.1 Inform (Interim) Emergency Director when appropriate Notifications have been made and submit completed copy of Appendix EP-103-4 Alert Phone List (Initial Notification) or Appendix EP-103-5 Alert Phone List (Escalation or De-Escalation) for (Interim) Emergency Director's Signature.

10. REFERENCES

- 10.1 Limerick Generating Station Emergency Plan
- 10.2 NUREG 0654, Criteria for Preparation and Evaluation of Radiological Emergency Response Plans and Preparedness in Support of Nuclear Power Plant.
Rev. 1

- 10.3 EP-303 Local Evacuation
- 10.4 EP-101 Classification of Emergencies
- 10.5 EP-304 Partial Plant Evacuation
- 10.6 EP-305 Site Evacuation
- 10.7 EP-306 Evacuation of the Information Center
- 10.8 A-31 Procedure for Prompt Notification
- 10.9 EP-291 Staffing Augmentation
- 10.10 EP-201 Technical Support Center (TSC) Activation
- 10.11 EP-202 Operations Support Center (OSC) Activation
- 10.12 EP-203 Emergency Operations Facility (EOF)
Activation
- 10.13 EP-317 Determination of Protective Action
Recommendations
- 10.14 EP-316 Cumulative Population Dose Calculations
for Airborne Release - Manual Method
- 10.15 EP-110 Personnel Assembly and Accountability
- 10.16 EP-208 Security Team Activation
- 10.17 EP-210 Dose Assessment Team Activation
- 10.18 EP-230 Chemistry Sampling and Analysis Team
Activation
- 10.19 EP-250 Personnel Safety Team Activation
- 10.20 EP-260 Fire and Damage Team Activation
- 10.21 EP-261 Damage Repair Group
- 10.22 EP-312 Radioactive Liquid Release

APPENDIX EP-103-1
ALERT NOTIFICATION MESSAGE

MESSAGE: This (is) (is not) a drill. This (is) (is not) a
drill. This is Limerick Generating Station calling to report an Alert.
My name is _____, telephone _____. Limerick Generating
Station is reporting an Alert declared at Unit No. _____. Time and date
of Alert classification are _____, _____. The basic
(24 hr. clock time) (date)
problem is _____. There (has been) (has not been)
an (airborne) (liquid) radioactive release from the plant. The plant
status is (stable)(improving)(degrading)(not known). There is no
protective action recommended. This (is) (is not) a drill. This (is)
(is not) a drill.

APPENDIX EP-103-2
Emergency Exposure Guidelines

<u>Function</u>	<u>Projected Whole Body Dose</u>	<u>Thyroid Dose</u>	<u>Authorized By</u>
1. Life Saving and Reduction of Injury	75 REM*	375 REM	(Interim) Emergency** Director
2. Operation of Equipment to Mitigate an Emergency	25 REM*	125 REM	(Interim) Emergency** Director
3. Protection of Health and Safety of the Public	5 REM	25 REM	(Interim) Emergency** Director
4. Other Emergency Activities	10 CFR 20 limits	10 CFR 20 limits	(Interim) Emergency Director
5. Re-entry/Recovery Activities	Station Administrative Guidelines	Station Administrative Guidelines	N/A

* Reference: EPA-520/1-75-001 Table 2.1

** Such exposure shall be on a voluntary basis

APPENDIX EP-103-3

ALERT DE-ESCALATION NOTIFICATION CHECKOFF LIST

MESSAGE: This (is) (is not) a drill. This (is) (is not) a drill. This is Limerick Generating Station calling to report a change in emergency classification. The Alert has been (de-escalated to an Unusual Event)(Terminated). Time and date are _____, _____.
(24 Hr Clock Time) (Date)

The plant status is (stable) (improving). My name is _____.

This (is) (is not) a drill. This (is) (is not) a drill.

APPENDIX EP-103-3
ALERT PHONE LIST
(INITIAL NOTIFICATION)

Time Initiated _____

Personnel/Agency To Be Notified	Phone Number	Time	Person Responding
a. [REDACTED]	Home Office [REDACTED] Brown phone, Ext. 156		
[REDACTED] Alternate [REDACTED]	Home Office [REDACTED]		
b. [REDACTED]	Office [REDACTED]		
c. [REDACTED]	[REDACTED]		
d. [REDACTED]	[REDACTED]		
e. [REDACTED]	[REDACTED]		
f. [REDACTED]	Home Office [REDACTED] (after tone, dial phone number which you are using)		
g. [REDACTED]	Home Office [REDACTED] Black Phone [REDACTED]		

TOP SECRET

APPENDIX EP-103-3
ALERT PHONE LIST
(INITIAL NOTIFICATION)

Time Initiated _____

Personnel/Agency To Be Notified Phone Number Time Person Responding

h. [REDACTED]

1st Choice:
Red Phone _____

2nd Choice:
[REDACTED] _____

3rd Choice:
[REDACTED] _____

Make this call last and remain on telephone until NRC disconnects

4th Choice:
HP Network _____

*Person contacting NRC must be Licensed Operator

5th Choice:
[REDACTED] _____

Agencies to be contacted after the above personnel/agencies have been notified

i. [REDACTED]

[REDACTED]

j. [REDACTED]

[REDACTED]

Completed By: _____ Time/Date _____

Verified By: _____
(INTERIM) EMERGENCY DIRECTOR

PROPRIETARY

APPENDIX EP-103-5
ALERT PHONE LIST
(ESCALATION OR DE-ESCALATION)

Time Initiated _____

Personnel/Agency To Be Notified	Phone Number	Time	Person Responding
a. [REDACTED]	Home Office [REDACTED]		
[REDACTED]	Home Office [REDACTED]		
b. [REDACTED]	Office [REDACTED]		
c. [REDACTED]	[REDACTED]		
d. [REDACTED]	1st Choice: Red Phone 2nd Choice: [REDACTED] 3rd Choice: [REDACTED] 4th Choice: HIP Network 5th Choice: [REDACTED]		

Make this call last and remain on telephone until NRC disconnects

*Person contacting NRC must be Licensed Operator

PROPRIETARY

APPENDIX EP-103-5
ALERT PHONE LIST
(ESCALATION OR DE-ESCALATION)

Time Initiated _____

Personnel/Agency To Be Notified Phone Number Time Person Responding

Agencies to be contacted after
the above personnel/agencies have
been notified

e.	[REDACTED]	[REDACTED]		
f.	[REDACTED]	[REDACTED]		
g.	[REDACTED]	[REDACTED]		

Completed By: _____ Prime Date _____

Verified By: _____
(INTERIM) EMERGENCY DIRECTOR

PROPRIETARY

3842106660

EP-104, Rev. 4
Page 1 of 16
VAW/MPG/rgs

J. Leahy 7/20/84

PHILADELPHIA ELECTRIC COMPANY
LIMERICK GENERATING STATION
EMERGENCY PLAN IMPLEMENTING PROCEDURE

EP-104 SITE EMERGENCY RESPONSE

1.0 PURPOSE

The purpose of this procedure is to provide guidelines for the site response to a Site Emergency.

2.0 RESPONSIBILITIES

- 2.1 Shift Supervision shall assume the role of the Interim Emergency Director when a Site Emergency occurs unless the Emergency Director is present and perform the necessary steps in this procedure.
- 2.2 The Station Superintendent or Alternate shall assume the role of the Emergency Director, report to the Technical Support Center or control room and relieve the Interim Emergency Director.
- 2.3 The Site Emergency Coordinator shall report to the Emergency Operations Facility and perform the necessary steps in this procedure.

3.0 APPENDICES

- 3.1 EP-104-1 Site Emergency Notification Message
- 3.2 EP-104-2 Emergency Exposure Guidelines
- 3.3 EP-104-3 Site Emergency De-Escalation Notification Message
- 3.4 EP-104-4 Site Emergency Phone List
(Initial Notification)
- 3.5 EP-104-5 Site Emergency Phone List
(Escalation or De-escalation)

VAW ONLY WHEN RE

4.0 PREREQUISITES

4.1 EP-101, Classification of Emergencies, completed

5.0 SPECIAL EQUIPMENT

None

6.0 SYMPTOMS

None

7.0 ACTION LEVEL

This procedure shall be implemented when an event occurs that is classified as a Site Emergency per EP-101, Classification of Emergencies.

8.0 PRECAUTIONS

8.1 Planned radiation exposures should be limited to the administrative guide levels in Appendix EP-104-2, Emergency Exposure Guidelines.

9.0 PROCEDURE

9.1 ACTIONS

9.1.1 (Interim) Emergency Director shall:

9.1.1.1 Verify the emergency classification as determined in EP-101 Classification of Emergencies unless determination has just been made.

9.1.1.2 Fill out Appendix EP-104-1, Site Emergency Notification Message, and give it to the Communicator.

- 9.1.1.3 Direct the communicator to complete notification of the appropriate parties as specified in Appendix EP-104-4, Site Emergency Phone List (Initial Notification) or Appendix EP-104-5, Alert Phone List (Escalation or De-escalation). The Communicator shall man the NRC RED Telephone until the NRC disconnects.
- 9.1.1.4 Contact the Station Superintendent and the Shift Technical Advisor, inform them of the situation, if not already done.
- 9.1.1.5 Direct the Information Center Staff (4256, 495-6767) to implement EP-306, Evacuation of the Information Center, if not already done. Inform the staff of the wind direction, if there is an airborne release.
- 9.1.1.6 If there is a radiological release, implement EP-305, Site Evacuation.
- 9.1.1.7 If there has not been a radiological release,

A.

[REDACTED]
Direct them to call for a "Total Project Evacuation" in accordance with Bechtel procedures.

[REDACTED]
and inform them that a Total Project Evacuation of Bechtel Construction personnel is being implemented.

THIS WILL CALL FOR THE ASSEMBLY OF PERSONNEL AT THE UPPER PARKING LOT AND POST #3. IF IT IS DESIRED THAT THEY LEAVE THE SITE, INFORM BECHTEL COMMAND POSTS AT THE UPPER PARKING LOG.

- C. Select the type of accountability desired for personnel in the protected area and implement the required actions below:

PROPRIETARY

1. Emergency Assembly Without
Accountability

- Make the following announcement

"THIS (IS) (IS NOT) A DRILL.
DESIGNATED EMERGENCY PERSONNEL
REPORT TO ASSIGNED EMERGENCY
RESPONSE FACILITIES. ALL OTHER
PERSONNEL STAND BY FOR FURTHER
ANNOUNCEMENT. THIS (IS) (IS NOT)
A DRILL."

2. Emergency Assembly With
Accountability

a. Select Unit 1 exit points as
follows:

Day Shift - TSC and
Administration Building
Afternoon Shift -
Administration Building Night
Shift - Administration
Building

b. Contact the (Interim)
Security Team Leader. Inform
him of the selected point(s),
that emergency assembly with
accountability is going to be
implemented, and to activate
the Security Team (EP-208)
and to perform personnel
accountability in accordance
with EP-110, Personnel
Assembly and Accountability

PROPRIETARY

[REDACTED] and inform them that
personnel leaving Unit 1 will
be reassembling at the
Personnel Processing Center
(PPC)

"THIS (IS) (IS NOT) A DRILL,
THIS (IS) (IS NOT) A DRILL.
DESIGNATED EMERGENCY
PERSONNEL REPORT TO ASSIGNED
EMERGENCY RESPONSE
FACILITIES. ALL OTHER

PERSONNEL LEAVE THE PROTECTED
AREA IMMEDIATELY THROUGH THE
(NAME OF EXIT AREA OR AREAS)
AND REASSEMBLE AT THE
PERSONNEL PROCESSING CENTER.
THIS (IS) (IS NOT) A DRILL.
THIS (IS) (IS NOT) A DRILL."

- 9.1.1.8 For off hours, if not already accomplished at the Alert stage, direct the Shift Clerk to activate the call list per EP-291, Staffing Augmentation. If Shift Clerk is not available, this function may be assigned to any available individual.
- 9.1.1.9 Direct the activation of the Technical Support Center in accordance with EP-201, Technical Support Center (TSC) Activation, if not already activated.
- 9.1.1.10 Direct the activation of the Emergency Operations Facility in accordance with EP-203, Emergency Operations Facility (EOF) Activation, if not already activated.
- 9.1.1.11 If the EOF has not been activated earlier, during the Alert Response procedure, direct a communicator to call EOF personnel (directing them to report to the EOF) using EP-279, EOF Group Phone List.
- 9.1.1.12 Assign an Operations Support Center coordinator (PO) if not already done, to direct available personnel to report to the Operations Support Center and to activate it in accordance with EP-202, Operations Support Center (OSC) Activation.
- 9.1.1.13 For samples, direct the Shift Chemistry Technician or Chemistry Sampling And Analysis Team Leader to implement EP-230, Chemistry Sampling And Analysis Team Activation.
- 9.1.1.14 For in-plant surveys, direct a Shift HP Technician or Personnel Safety Team Leader to implement EP-250, Personnel Safety Team Activation.

- 9.1.1.15 For field surveys, when a release of gaseous radioactive material has occurred or is suspected, direct a Shift HP Technician or Dose Assessment Team Leader to implement EP-210, Dose Assessment Team Activation.
- 9.1.1.16 For a release, at or greater than the Alert level in EP-101, Classification of Emergencies, or at the discretion of the Emergency Director, direct the Dose Assessment Team Leader to implement EP-210, Dose Assessment Team Activation. On an interim bases, direct the Shift Technical Advisor to perform dose projections using EP-316, Cumulative Population Dose Calculations for Airborne Releases-Manual Method or RMMS Computer and implement EP-317, Determination of Protective Action Recommendations.
- 9.1.1.17 For fire/damage repair direct the Maintenance Shift Assistant Foreman or Fire and Damage Team Leader to implement EP-260, Fire and Damage Team Activation and/or EP-261, Damage Repair Group.
- 9.1.1.18 For a liquid release, implement EP-312, Radioactive Liquid Release, if required.
- 9.1.1.19 For Security matters, contact Security Shift Supervision and direct implementation of EP-208, Security Team Activation, unless previously done.

9.2 FOLLOW-UP

- 9.2.1 (Interim) Emergency Director shall:
- 9.2.1.1 Verify that the Technical Support Center, Emergency Operations Facility and the Operations Support Center have been activated.
- 9.2.1.2 Periodically evaluate the event classification in accordance with EP-101, Classification of Emergencies and escalate or de-escalate the classification, as necessary.

- 9.2.1.3 If classification is de-escalated, fill out Appendix EP-104-3, Site Emergency De-Escalation Notification Message and give it to the communicator and direct the communicator to perform notification of the appropriate parties listed in Appendix EP-104-5, Site Emergency Phone List (Escalation or De-escalation).
- 9.2.1.4 Obtain the following information as necessary to formulate further actions:
- A. Security Status from Security Team Leader
 - B. Sample analysis from Shift Chemistry Technician or Chemistry Sampling And Analysis Team Leader
 - C. In-plant surveys from Shift HP Technician or Personnel Safety Team Leader
 - D. Field surveys from Shift HP Technician or Dose Assessment Team Leader
 - E. Dose projections and protective action recommendations from Shift Technical Advisor or Dose Assessment Team Leader
 - F. Fire/Damage repair status from the Maintenance Shift Assistant Foreman or Fire and Damage Team Leader.
 - G. Notification Results from Communicator.
- 9.2.1.5 Discuss protective action recommendations with the Site Emergency Coordinator.
- 9.2.1.6 Determine which additional support personnel are necessary for emergency functions and direct the shift clerk or other assigned communicator to contact those personnel.
- 9.2.1.7 Provide site personnel with public address (PA) announcements for any major changes in plant emergency status, such as changing emergency action levels and evacuations.

- 9.2.1.8 Evaluate the need and order evacuation of affected areas as necessary.

Refer to the following procedures:

EP-303 Local Evacuation

EP-305 Site Evacuation

- 9.2.1.9 Perform the following until relieved by the Site Emergency Coordinator:

- A. Discuss protective action recommendations with the Dose Assessment Team Leader.
- B. Provide protective action recommendations, if necessary, to the Pennsylvania Bureau of Radiation Protection.
- C. Inform the various emergency response groups if the recovery phase organization is to be implemented.

- 9.2.2 The Communicator shall:

- 9.2.2.1 Inform the Emergency Director when appropriate notifications have been made and submit completed copy of Attachment EP-104-4 Site Emergency Phone List (Initial Notification) or Appendix EP-104-5, Site Emergency Phone List (Escalation or De-escalation) for Emergency Directors Signature.

10. REFERENCES

- 10.1 Limerick Generating Station Emergency Plan
- 10.2 NUREG 0654, Criteria For Preparation and Evaluation of Radiological Emergency Response Plans and Preparedness in Support of Nuclear Power Plants.
Rev. 1
- 10.3 EP-101 Classification of Emergencies
- 10.4 A-31 Procedure for Prompt Notification
- 10.5 EP-291 Staffing Augmentation

- 10.6 EP-201 Technical Support Center (TSC) Activation
- 10.7 EP-202 Operations Support Center (OSC) Activation
- 10.8 EP-203 Emergency Operations Facility (EOF) Activation
- 10.9 EP-317 Determination of Protective Action
Recommendations
- 10.10 EP-316 Cumulative Population Dose Calculations
For Airborne Releases-Manual Method
- 10.11 EP-305 Site Evacuation
- 10.12 EP-306 Evacuation of the Information Center
- 10.13 EP-110 Personnel Assembly and Accountability
- 10.14 EP-208 Security Team Activation
- 10.15 EP-210 Dose Assessment Team Activation
- 10.16 EP-230 Chemistry Sampling and Analysis Team
Activation
- 10.17 EP-250 Personnel Safety Team Activation
- 10.18 EP-260 Fire and Damage Team Activation
- 10.19 EP-261 Damage Repair Group
- 10.20 EP-312 Radioactive Liquid Release
- 10.21 EP-279 Emergency Operations Facility (EOF) Group
Phone List

APPENDIX EP-104-1

SITE EMERGENCY NOTIFICATION MESSAGE

Message: This (is)(is not) a drill. This (is)(is not) a drill. This is Limerick Generating Station calling to report a Site Emergency. My name is _____, telephone _____. Limerick Generating Station is reporting a Site Emergency declared at Unit No. ____.

Time and date of Site Emergency classification are _____,
(24 hr. clock time)

(Date)

The basic problem is _____.

There (has been) (has not been) an (airborne) (liquid) radioactive release from the plant. The plant status is (stable) (improving) (degrading) (not known). There is no protective action recommended. This (is) (is not) a drill. This (is) (is not) a drill.

APPENDIX EP-104-2

EMERGENCY EXPOSURE GUIDELINES

<u>Function</u>	<u>Projected Whole Body Dose</u>	<u>Thyroid Dose</u>	<u>Authorized Ey</u>
1. Life Saving and Reduction of Injury	75 REM*	375 REM	(Interim) Emergency** Director
2. Operation of Equipment to Mitigate an Emergency	25 REM*	125 REM	(Interim) Emergency** Director
3. Protection of Health and Safety of the Public	5 REM	25 REM	(Interim) Emergency** Director
4. Other Emergency Activities	10 CFR 20 limits	10 CFR 20 limits	(Interim) Emergency Director
5. Re-Entry/ Recovery Activities	Station Administrative Guide Lines	Station Administration Guide Lines	N/A

* Reference: EPA-520/1-75-001 Table 2.1

** Such exposure shall be on a voluntary basis

APPENDIX EP-104-3

SITE EMERGENCY DE-ESCALATION NOTIFICATION MESSAGE

MESSAGE: This (is) (is not) a drill. This (is) (is not) a drill.
This is Limerick Generating Station calling to report a change in
emergency action level. The site emergency has been (de-escalated to
an) (Unusual Event) (Alert) (Terminated). Time and date are
_____, _____. The plant status is (stable)
(24 Hr Clock Time) (Date)
(improving). My name is _____. This (is) (is not) a drill.
This (is) (is not) a drill.

APPENDIX EP-104-4
SITE EMERGENCY PHONE LIST
(INITIAL NOTIFICATION)

Time Initiated _____

Personnel/Agency to be notified Phone Number Time Person Responding

a.	[REDACTED]	Home - [REDACTED] Office - [REDACTED]	[REDACTED]	[REDACTED]	[REDACTED]
	[REDACTED]	Home - [REDACTED] Office - [REDACTED]	[REDACTED]	[REDACTED]	[REDACTED]
	[REDACTED]	Office - [REDACTED]	[REDACTED]	[REDACTED]	[REDACTED]
	[REDACTED]	[REDACTED]	[REDACTED]	[REDACTED]	[REDACTED]
d.	[REDACTED]	[REDACTED]	[REDACTED]	[REDACTED]	[REDACTED]
e.	[REDACTED]	[REDACTED]	[REDACTED]	[REDACTED]	[REDACTED]
f.	[REDACTED]	Home - [REDACTED] Office - [REDACTED] Pager [REDACTED]	[REDACTED]	[REDACTED]	[REDACTED]
			(After tone, dial phone number which you are using)		
g.	[REDACTED]	Home - [REDACTED] Office - [REDACTED]	[REDACTED]	[REDACTED]	[REDACTED]

PROPRIETARY

APPENDIX EP-104-4 (CONT'D)
SITE EMERGENCY PHONE LIST (CONT'D)
(INITIAL NOTIFICATION)

Personnel/Agency to be notified

Phone Number

Time

Person Responding

Agencies to be contacted after the above personnel/agencies have been notified

h. [REDACTED]

[REDACTED]
2nd choice:
[REDACTED]
3rd choice:
[REDACTED]
4th choice:
[REDACTED]
5th choice:
[REDACTED]

Make this call last and remain on telephone until NRC disconnects

*Person contacting NRC must be licensed operator

i. Berks County Emergency Management Agency

[REDACTED]

j. Chester County Emergency Services

[REDACTED]

PROPRIETARY

Completed By: _____
Verified By: _____
(Interim) Emergency Director

Time/Date _____

APPENDIX EP-104-5
SITE EMERGENCY PHONE LIST
(ESCALATION OR DE-ESCALATION)

Time Initiated _____

Personnel/Agency to be notified

a. [REDACTED]

[REDACTED]

b. [REDACTED]

c. [REDACTED]

d. [REDACTED]

Home -
Office -

Home -
Office -

Office -

Phone Number

[REDACTED]

[REDACTED]

[REDACTED]

[REDACTED]

[REDACTED]

[REDACTED]

Time

Person Responding

PROPRIETARY

| Make this call last and remain on telephone until NRC disconnects

| *person contacting NRC must be licensed operator

APPENDIX EP-104-5 (CONT'D)
SITE EMERGENCY PHONE LIST (CONT'D)
(ESCALATION OR DE-ESCALATION)

Personnel/Agency to be notified

Agencies to be contacted after the
above personnel/agencies have been
notified

- e. [REDACTED]
- f. [REDACTED]
- g. [REDACTED]

Phone Number	Time	Person Responding
[REDACTED]	[REDACTED]	[REDACTED]
[REDACTED]	[REDACTED]	[REDACTED]
[REDACTED]	[REDACTED]	[REDACTED]

PROPRIETARY

Completed By: _____
Verified By: _____
(Interim) Emergency Director

Time/Date _____

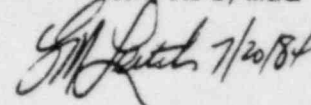
Handwritten signature and date: 7/20/84

PHILADELPHIA ELECTRIC COMPANY
LIMERICK GENERATING STATION
EMERGENCY PLAN IMPLEMENTING PROCEDURE

EP-105 GENERAL EMERGENCY RESPONSE

1.0 PURPOSE

The purpose of this procedure is to provide guidelines for the site response to a General Emergency.

2.0 RESPONSIBILITIES

- 2.1 Shift Supervision shall assume the role of Interim Emergency Director when a General Emergency occurs unless the Emergency Director is present and performs the necessary steps in this procedure.
- 2.2 The Station Superintendent or alternate shall assume the role of the Emergency Director, report to the Technical Support Center or control room and relieve the Interim Emergency Director.
- 2.3 The Site Emergency Coordinator shall report to the Emergency Operations Facility and perform the necessary steps in this procedure.

3.0 APPENDICES

- 3.1 EP-105-1 General Emergency Notification Message
- 3.2 EP-105-2 Emergency Exposure Guidelines
- 3.3 EP-105-3 General Emergency De-escalation Notification Message
- 3.4 EP-105-4 General Emergency Phone List (Initial Notification)
- 3.5 EP-105-5 General Emergency Phone List (Escalation or De-escalation)

CONTROLLED

VALID ONLY WHEN RED

4.0 PREREQUISITES

4.1 EP-101 Classification of Emergencies, completed

5.0 SPECIAL EQUIPMENT

None

6.0 SYMPTOMS

None

7.0 ACTION LEVEL

7.1 This procedure shall be implemented when an event occurs that is classified as a General Emergency per EP-101 Classification of Emergencies.

8.0 PRECAUTIONS

8.1 Planned radiation exposures should be limited to the administrative guide levels in Appendix EP-105-2, Emergency Exposure Guidelines.

9.0 PROCEDURE

9.1 ACTIONS

9.1.1 (Interim) Emergency Director shall:

9.1.1.1 Verify the emergency classification as determined in EP-101, Classification of Emergencies unless determination has just been made.

9.1.1.2 Fill out Appendix EP-105-1, General Emergency Notification Message, and give it to the communicator.

- 9.1.1.3 Direct communicator to complete notification of the appropriate parties as specified in Appendix EP-105-4, General Emergency Phone List (Initial Notification) or Appendix EP-105-5, General Emergency Phone List (Escalation or De-escalation). The Communicator shall man the NRC RED telephone on a continuous basis until the NRC disconnects.
- 9.1.1.4 Contact the Station Superintendent and the Shift Technical Advisor, inform them of the situation, if not already done.
- 9.1.1.5 Implement EP-306, Evacuation of the Information Center, if not already done. Inform the staff of the wind direction, if there is an airborne release.
- 9.1.1.6 If there is a radiological release, implement EP-305, Site Evacuation.
- 9.1.1.7 If there has not been a radiological release,

A.

[REDACTED]

Direct them to call for a "Total Project Evacuation" in accordance with Bechtel procedures.

B.

[REDACTED] and inform [REDACTED] that a Total Project Evacuation of Bechtel Construction personnel is being implemented.

THIS WILL CALL FOR THE ASSEMBLY OF PERSONNEL AT THE UPPER PARKING LOT AND POST #3. IF IT IS DESIRED THAT THEY LEAVE THE SITE, INFORM BECHTEL COMMAND POSTS AT THE UPPER PARKING LOT.

- C. Select the type of accountability desired for personnel in the protected area and implement the required actions below:

PROPRIETARY

1. Emergency Assembly Without
Accountability

- Make the following announcement

"THIS (IS) (IS NOT) A DRILL.
DESIGNATED EMERGENCY PERSONNEL
REPORT TO ASSIGNED EMERGENCY
RESPONSE FACILITIES. ALL OTHER
PERSONNEL STAND BY FOR FURTHER
ANNOUNCEMENT. THIS (IS) (IS NOT)
A DRILL."

2. Emergency Assembly With
Accountability

a. Select Unit 1 exit points as
follows:

Day Shift - TSC and
Administration Building
Afternoon Shift -
Administration Building Night
Shift - Administration
Building

b. Contact the (Interim)
Security Team Leader. Inform
him of the selected exit
point(s), that emergency
assembly with accountability
is going to be implemented,
and to activate the Security
Team (EP-208) and to perform
personnel accountability in
accordance with EP-110,
Personnel Assembly and
Accountability.

c.

and inform them that
personnel leaving Unit 1 will
be reassembling at the
Personnel Processing Center
(PPC).

PROPRIETARY

"THIS (IS) (IS NOT) A DRILL,
THIS (IS) (IS NOT) A DRILL.
DESIGNATED EMERGENCY
PERSONNEL REPORT TO ASSIGNED
EMERGENCY RESPONSE
FACILITIES. ALL OTHER
PERSONNEL LEAVE THE PROTECTED
AREA IMMEDIATELY THROUGH THE
(NAME OF EXIT AREA OR AREAS)
AND REASSEMBLE AT THE
PERSONNEL PROCESSING CENTER.
THIS (IS) (IS NOT) A DRILL.
THIS (IS) (IS NOT) A DRILL."

- 9.1.1.8 For OFF-hours, if not already accomplished during an Alert or Site Emergency Response procedure, direct the Shift Clerk to activate the call list using EP-291, Staffing Augmentation. If Shift Clerk is not available, this function may be assigned to any available individual.
- 9.1.1.9 Direct the activation of the Technical Support Center in accordance with EP-201, Technical Support Center (TSC) Activation, if not already activated.
- 9.1.1.10 Direct activation of the Emergency Operations Facility in accordance with EP-203, Emergency Operations Facility (EOF) Activation, if not already activated.
- 9.1.1.11 If the EOF has not been activated earlier, during an Alert or Site Emergency Response procedure, direct a communicator to call EOF personnel (directing them to report to the EOF) using EP-279, EOF Group Phone List.
- 9.1.1.12 Assign an Operations Support Center Coordinator (PO), if not already done, to direct available personnel to report to the Operations Support Center and to activate it in accordance with EP-202, Operations Support Center (OSC) Activation.

- 9.1.1.13 For samples, direct the Shift Chemistry Technician or Chemistry Sampling And Analysis Team Leader to implement EP-230 Chemistry Sampling And Analysis Team Activation.
- 9.1.1.14 For in-plant surveys, direct a Shift HP Technician or Personnel Safety Team Leader to implement EP-250, Personnel Safety Team Activation.
- 9.1.1.15 For field surveys when a release of gaseous radioactive material has occurred or is suspected, direct Dose Assessment Team Leader to implement EP-210, Dose Assessment Team Activation.
- 9.1.1.16 For a release at or greater than the Alert level in EP-101, Classification of Emergencies, or at the discretion of the Emergency Director, direct the Dose Assessment Team Leader to implement EP-210, Dose Assessment Team Activation. On an interim bases, direct the Shift Technical Advisor to perform dose projections using EP-316, Cumulative Population Dose Calculations for Airborne Releases-Manual Method or RMMS Computer and implement EP-317, Determination of Protective Action Recommendations.
- 9.1.1.17 For fire/damage repair direct the Maintenance Shift Assistant Foreman or Fire and Damage Team Leader to implement EP-260, Fire and Damage Team Activation and/or EP-261 Damage Repair Group.
- 9.1.1.18 For a liquid release, implement EP-312, Radioactive Liquid Release, if required.
- 9.1.1.19 For Security matters, contact Security Shift Supervision and direct implementation of EP-208, Security Team Activation, unless previously done.

9.2 FOLLOW-UP

- 9.2.1 (Interim) Emergency Director shall:
- 9.2.1.1 Verify that the Technical Support Center, Emergency Operations Facility and the Operations Support Center have been activated.
 - 9.2.1.2 Periodically evaluate the event classification in accordance with EP-101, Classification of Emergencies. If the conditions change, deescalate to an appropriate classification.
 - 9.2.1.3 If classification is de-escalated, fill out Appendix EP-105-3, General Emergency De-escalation Notification Message, and give it to the communicator and direct the communicator to perform notification of the appropriate parties listed in Appendix EP-105-5, General Emergency Phone List (Escalation or De-escalation).
 - 9.2.1.4 Obtain the following information as necessary to formulate further actions:
 - A. Security Status from Security Team Leader
 - B. Sample analysis from Shift Chemistry Technician or Chemistry Sampling and Analysis Team Leader
 - C. In-plant surveys from Shift HP Technician or Personnel Safety Team Leader
 - D. Field surveys from Shift HP Technician or Dose Assessment Team Leader
 - E. Dose projections and protective action recommendations from Shift Technical Advisor or Dose Assessment Team Leader

F. Fire/Damage Repair status from the Maintenance Shift Assistant Foreman or Fire and Damage Team Leader

G. Notification results from Communicator

9.2.1.5 Discuss protective action recommendations with the Site Emergency Coordinator.

9.2.1.6 If not already performed, determine which additional support personnel are necessary for emergency functions and direct the Shift Clerk or other assigned person to contact those personnel.

9.2.1.7 Provide site personnel with public address (PA) speaker announcements for any major changes in plant emergency status, such as changing emergency action levels.

9.2.1.8 Evaluate the need and order evacuation of effected areas as necessary.

Refer to the following procedures:

EP-303 Local Evacuation

EP-305 Site Evacuation

EP 306 Evacuation of the Information Center

9.2.1.9 Perform the following until relieved by the Site Emergency Coordinator:

A. Discuss protective action recommendations with the Dose Assessment Team Leader.

B. Provide protective action recommendations to the Pennsylvania Bureau of Radiation Protection.

C. Inform the various emergency response groups if the recovery phase organization is to be implemented.

9.2.2 The Communicator shall:

9.2.2.1 Inform the Emergency Director when appropriate notifications have been made and submit completed copy of Appendix EP-105-4 General Emergency Phone List (Initial Notification) or Appendix EP-105-5 (Escalation or De-escalation) for Emergency Director's signature.

10.0 REFERENCES

- 10.1 Limerick Generating Station Emergency Plan
- 10.2 NUREG 0654, Criteria for Preparation and Evaluation of Radiological Emergency Response Plans in Support of Nuclear Power Plants
- 10.3 EP-101 Classification of Emergencies
- 10.4 EP-201 Technical Support Center (TSC) Activation
- 10.5 EP-202 Operations Support Center (OSC) Activation
- 10.6 EP-203 Emergency Operations Facility (EOF) Activation
- 10.7 EP-291 Staffing Augmentation
- 10.8 EP-305 Site Evacuation
- 10.9 EP-306 Evacuation of the Information Center
- 10.10 EP-317 Determination of Protective Action Recommendations
- 10.11 EP-316 Cumulative Population Dose Calculations For Airborne Releases - Manual Method
- 10.12 EP-110 Personnel Assembly and Accountability
- 10.13 EP-208 Security Team Activation
- 10.14 EP-210 Dose Assessment Team Activation
- 10.15 EP-230 Chemistry Sampling and Analysis Team Activation
- 10.16 EP-250 Personnel Safety Team Activation

- 10.17 EP-260 Fire and Damage Team Activation
- 10.18 EP-261 Damage Repair Group
- 10.19 EP-312 Radioactive Liquid Release
- 10.20 EP-279 Emergency Operations Facility (EOF) Group
Phone List

APPENDIX EP-105-1

GENERAL EMERGENCY NOTIFICATION MESSAGE

MESSAGE: This (is)(is not) a drill. This (is)(is not) a drill.

This is the Limerick Generating Station calling to report a General
Emergency. My name is _____, telephone
_____. Limerick Generating Station is reporting a General
Emergency declared at Unit No. _____. Time and date of General
Emergency classification are

_____ (24 Hr Clock Time) _____ (Date)

The basic problem is _____.

There (has been) (has not been) an (airborne) (liquid) radioactive
release from the plant. The plant status is (stable) (improving)
(degrading) (not known). The protective action recommended is

* _____. The affected area is _____. This
(is) (is not) a drill. This (is) (is not) a drill.

* If a General Emergency has been declared without prior
emergency classification provide the recommendation to
shelter within the 2 mile radius and 5 miles downwind of the
plant. If PEMA & BRP are not available, make the
recommendation directly to the counties.

APPENDIX EP-105-2

EMERGENCY EXPOSURE GUIDELINES

<u>Function</u>	<u>Projected Whole Body Dose</u>	<u>Thyroid Dose</u>	<u>Authorized By</u>
1. Life Saving and Reduction of Injury	75 REM*	375 REM	(Interim) Emergency** Director
2. Operation of Equipment to Mitigate an Emergency	25 REM*	125 REM	(Interim) Emergency** Director
3. Protection of Health and Safety of the Public	5 REM	25 REM	(Interim) Emergency** Director
4. Other Emergency Activities	10 CFR 20 limits	10 CFR 20 limits	(Interim) Emergency Director
5. Re-entry/Recovery Activities	Station Administrative Guidelines	Station Administrative Guidelines	N/A

* Reference: EPA-520/1-75-001 Table 2.1
 ** Such exposure shall be on a voluntary basis

APPENDIX EP-105-3

GENERAL EMERGENCY DE-ESCALATION NOTIFICATION MESSAGE

Message: This (is) (is not) a drill. This (is) (is not) a
drill. This is Limerick Generating Station calling to report a
change in emergency action level. The General Emergency has been
(de-escalated to) (An Unusual Event) (An Alert) (An Site
Emergency) (Terminated). Time and date are

_____ , _____. The plant status is (stable)
(24 Hr Clock Time) (Date)

(improving). My name is _____.

This (is) (is not) a drill. This (is) (is not) a drill.

APPENDIX EP-105-3
GENERAL EMERGENCY PHONE LIST
(INITIAL NOTIFICATION)

Time Initiated _____

Personnel/Agency To Be Notified Phone Number Time Person Responding

a.	[REDACTED]	Home Office	[REDACTED]		
	[REDACTED]	Home Office	[REDACTED]		
b.	[REDACTED]	Office	[REDACTED]		
c.	[REDACTED]		[REDACTED]		
d.	[REDACTED]		[REDACTED]	(8AM-4PM)	
e.	[REDACTED]		[REDACTED]	(After 4PM)	
				(8AM-4PM)	
				(8AM-4PM)	
				(PEMA after hours)	
f.	[REDACTED]	Home Office	[REDACTED]		
		Pager	[REDACTED]		
g.	[REDACTED]	Home Office	[REDACTED]		

PROPRIETARY

APPENDIX EP-105-3
GENERAL EMERGENCY PHONE LIST
(INITIAL NOTIFICATION)

Time Initiated _____

Personnel/Agency To Be Notified Phone Number Time Person Responding

h. [REDACTED]

1st Choice:

[REDACTED]

2nd Choice:

[REDACTED]

3rd Choice:

[REDACTED]

4th Choice:

[REDACTED]

5th Choice:

[REDACTED]

Make this call last and remain on telephone until NRC disconnects

*Person contacting NRC must be Licensed Operator

Agencies to be contacted after the above personnel/agencies have been notified

i. [REDACTED] y

[REDACTED]

[REDACTED]

[REDACTED]

Completed By: _____

Time/Date _____

Verified By: _____

(INTERIM) EMERGENCY DIRECTOR

PROPRIETARY

APPENDIX EP-105-5
GENERAL EMERGENCY PHONE LIST
(ESCALATION OR DE-ESCALATION)

Time Initiated _____

Personnel/Agency To Be Notified	Phone Number	Time	Person Responding
a. [REDACTED]	Home Office [REDACTED]		
[REDACTED]	Home Office [REDACTED]		
b. [REDACTED]	Office [REDACTED]		
c. [REDACTED]	[REDACTED]		
d. [REDACTED]	1st Choice: [REDACTED]		
	2nd Choice: [REDACTED]		
	3rd Choice: [REDACTED]		
	4th Choice: [REDACTED]		
	5th Choice: [REDACTED]		

Make this call last and remain on telephone until NRC disconnects

PROPRIETARY

APPENDIX EP-105-5
GENERAL EMERGENCY PHONE LIST
(ESCALATION OR DE-ESCALATION)

Time Initiated _____

Personnel/Agency To Be Notified

Phone Number

Time

Person Responding

Agencies to be contacted after
the above personnel/agencies have
been notified

[REDACTED]

[REDACTED]

f. [REDACTED]

[REDACTED]

g. [REDACTED]

[REDACTED]

Completed By: _____

Time/D _____

Verified By: _____
(INTERIM) EMERGENCY DIRECTOR

PROPRIETARY

3842106680

EP-230 Rev. 3

Page 1 of 10

TJY/RGH/jmv

SAH 7/20/84

PHILADELPHIA ELECTRIC COMPANY
LIMERICK GENERATING STATION
EMERGENCY PLAN IMPLEMENTING PROCEDURE

EP-230 CHEMISTRY SAMPLING AND ANALYSIS TEAM ACTIVATION

1.0 PURPOSE

The purpose of this procedure is to provide guidelines for the actions required to activate the Chemistry Sampling and Analysis Team.

2.0 RESPONSIBILITIES

- 2.1 The (Interim) Emergency Director shall direct the Chemistry Sampling and Analysis Team Leader to activate a team, when required.
- 2.2 The Chemistry Sampling and Analysis Team Leader shall appoint a group leader to perform the steps necessary in this procedure.
- 2.3 The Chemistry Sampling and Analysis Group Leader shall direct the group members to perform the steps necessary in this procedure.

3.0 APPENDICES

- 3.1 EP-230-1 Emergency Exposure Guidelines
- 3.2 EP-230-2 Sample and Analysis Logsheet

4.0 PREREQUISITES

None

5.0 SPECIAL EQUIPMENT

None

CONTROLLED

VALID ONLY WHEN RED

6.0 SYMPTOMS

None

7.0 ACTION LEVEL

7.1 The Chemistry Sampling and Analysis Group will be activated at the discretion of the (Interim) Emergency Director.

8.0 PRECAUTIONS

8.1 Planned radiation exposures should be limited to the administrative guide levels in Appendix EP-230-1 Emergency Exposure Guidelines.

8.2 Continuous coverage by a Health Physics Technician may substitute for the Radiation Work Permit.

8.3 Every effort should be made to maintain the individual and man-rem exposures of the group to ALARA.

9.0 PROCEDURE

9.1 ACTIONS

9.1.1 The (Interim) Emergency Director shall:

9.1.1.1 Direct the (Interim) Chemistry Sampling and Analysis Team Leader to collect samples, as necessary, and analyze the samples or use offsite support groups for the analysis.

9.1.2 Senior Shift Chemistry technician shall:

9.1.2.1 Report to the Chemistry Field Office and verify habitability in accordance with EP-330, Emergency Response Facility Habitability. Report to the Chemistry Area on the 2nd floor of the Administration Building if the Chemistry Lab is not habitable. If the Chemistry Lab habitability is degraded, time spent in the lab analyzing samples should be minimized and protective measures shall be employed.

Consideration should be given to sending the samples offsite for analysis.

- 9.1.2.2 After discussing the situation with the Emergency Director to determine the priorities of group activation and immediate responses of the Chemistry Sampling and Analysis Team, assume the role of Interim Chemistry Sampling and Analysis Team Leader.

AT ANY POINT IN THIS PROCEDURE, THE CHEMISTRY SAMPLING AND ANALYSIS TEAM LEADER WILL REPORT TO THE TSC AND RELIEVE THE INTERIM TEAM LEADER ONCE FULLY COGNIZANT OF THE SITUATION.

- 9.1.2.3 Appoint Group Leaders from available personnel and/or assume the role of group leader and group member(s) (until relieved) and complete the appropriate steps in this procedure.

- 9.1.2.4 Assign sampling tasks to Group Leaders. Brief Group Leaders on plant status and potential or existing radiological conditions and/or hazards, as the information becomes available.

- 9.1.2.5 Request emergency exposure authorizations from the Emergency Director for the appropriate group members as required.

- 9.1.3 Chemistry Sampling and Analysis Group Leader shall:

- 9.1.3.1 Assemble the Chemistry Sampling and Analysis Group Members at the Chemistry Field Office and perform accountability if required per EP-110 Personnel Assembly and Accountability.

- 9.1.3.2 Obtain all PASS keys from the key cabinets located in the chemistry field office or chemistry administration office.

- 9.1.3.3 Direct group member(s) to prepare sampling equipment using the appropriate procedures.

- 9.1.3.4 Direct group member(s) to prepare sample preparation station, Counting Room and analysis instrumentation using the appropriate procedures.

- 9.1.3.5 Appoint group member(s) as necessary to assist in maintaining accountability logsheet, sampling and analysis logsheet, plant status record keeping and other appointed duties.
- 9.1.3.6 Evaluate sampling conditions and/or locations identified in steps 9.1.3.3 through 9.1.3.7 below and instruct group members to take the necessary samples using indicated procedures.
- 9.1.3.7 Refer to the following procedures to sample primary coolant and drywell atmosphere as necessary:
- EP-231 Operation of Post Accident Sampling System (PASS)
 - EP-233 Retrieving And Changing Sample Filters And Cartridges From The Containment Leak Detector During Emergencies
 - EP-234 Obtaining Containment Gas Samples From the Containment Leak Detector During Emergencies
 - EP-235 Obtaining Reactor Water Samples From Sample Sinks Following Accident Conditions
- 9.1.3.8 In the event of a unplanned radioactive liquid release, to the Schuylkill River, obtain samples of the blowdown line water in accordance with:
- EP-236 Obtaining Cooling Tower Blowdown Line Water Samples Following Radioactive Liquid Release After Accident Conditions

- 9.1.3.9 Use the following procedures to obtain samples, as necessary, from the various sample points.

North and South Stack

EP-237 Obtaining the Iodine/Particulate and/or gas samples from the North Vent Wide Range Gas Monitor (WRGM)

Liquid Radwaste

EP-238 Obtaining Liquid Radwaste Samples from Radwaste Sample Sink Following Accident Conditions

Off Gas

EP-240 Obtaining Off Gas Samples from the Air Ejector/Holdup pipe Discharge

Reactor Enclosure or Suppression Pool

EP-231 Operation of Post Accident Sampling Systems (PASS)

- 9.1.3.10 Use the following procedures for the preparation and handling of highly radioactive samples.

EP-241 Sample Preparation and Handling of Highly Radioactive Liquid Samples

EP-242 Sample Preparation and Handling of Highly Radioactive Particulate Filters and Iodine Cartridges

EP-243 Sample Preparation and Handling of Highly Radioactive Gas Samples

- 9.1.3.11 Periodically have group member exposures evaluated to ensure that group members do not exceed normal administrative exposure guidelines without prior approval of the (Interim) Emergency Director.

- 9.1.3.12 As required, request the Chemistry Sampling and Analysis Team Leader to obtain emergency exposure authorizations from the (Interim) Emergency Director for affected group members.

- 9.1.3.13 Assign a sample number to each sample to be analyzed and record on Appendix EP-230-2 Sample and Analysis Logsheet. Complete the appropriate line for each sample taken as the information becomes available.
- 9.1.3.14 Appropriately file the data sheets and analysis reports with Appendix EP-230-2 Sample and Analysis Logsheet for each sample analyzed.
- 9.1.4 Chemistry Sampling and Analysis Group Members shall:
 - 9.1.4.1 Assemble the necessary equipment needed to obtain and analyze samples. Label all sample containers before sampling.
 - 9.1.4.2 Collect and analyze samples as directed by the Group Leader.
 - 9.1.4.3 Give data sheets and analysis reports to the sampling and analysis Group Leader.

9.2 FOLLOW-UP

- 9.2.1 The (Interim) Chemistry Sampling and Analysis Team Leader shall:
 - 9.2.1.1 Report the results of these analyses to the (Interim) Emergency Director, Dose Assessment Team Leader and Health Physics and Chemistry Coordinator.
 - 9.2.1.2 Provide group leaders with periodic plant status changes including significant radiation exposure and radioactive contamination problems which may affect the functions of the team.
 - 9.2.1.3 If necessary, use the post accident sampling analysis off-site capabilities by referring to EP-244, Off-Site Analysis of High Activity Samples.
 - 9.2.1.4 Provide additional personnel support, if necessary, using EP-292 Chemistry Sampling and Analysis Team Phone List.

- 9.2.2 Chemistry Sampling and Analysis Group Leader shall:
 - 9.2.2.1 Report results of samples and analysis to the Chemistry Sampling and Analysis Team Leader.
 - 9.2.2.2 Provide Group Members with periodic plant status changes to include radiological conditions which may affect the group.
 - 9.2.2.3 Request augmentative personnel from the Chemistry Sampling and Analysis Team Leader as required.

10.0 REFERENCES

- 10.1 Limerick Generating Station Emergency Plan
- 10.2 NUREG 0654, Rev. 2 - Preparation and Evaluation of Radiological Emergency Response Plans and Preparedness In Support of Nuclear Power Plants
- 10.3 EP-231 Operation of Post Accident Sampling System (PASS)
- 10.4 EP-233 Retrieving and Changing Sample Filters and Cartridges from the Containment Leak Detector during Emergencies
- 10.5 EP-234 Obtaining Containment Gas Samples from the Containment Leak Detector During Emergencies
- 10.6 EP-235 Obtaining Reactor Water Samples from Sample Sinks Following Accident Conditions
- 10.7 EP-236 Obtaining Cooling Tower Blowdown Line Samples Following Radioactive Liquid Releases After Accident Conditions
- 10.8 EP-237 Obtaining the Iodine/Particulate Samples and/or gas samples the North Vent Wide Range Gas Monitor (WRGM)
- 10.9 EP-238 Obtaining Liquid Radwaste Samples from the Radwaste Sample Sink Following Accident Conditions

- 10.10 EP-240 Off Gas Samples from the Air Ejector/Holdup
Pipe Discharge
- 10.11 EP-241 Sample Preparation and Handling of Highly
Radioactive Liquid Samples
- 10.12 EP-242 Sample Preparation and Handling of Highly
Radioactive Particulate Filters and Iodine
Cartridges
- 10.13 EP-243 Sample Preparation and Handling of Highly
Radioactive Gas Samples
- 10.14 EP-292 Chemistry Sampling and Analysis Team Phone List
- 10.15 EP-110 Personnel Assembly and Accountability
- 10.16 EP-244 Off-Site Analysis of High Activity Samples

APPENDIX EP-230-1
Emergency Exposure Guidelines

<u>Function</u>	<u>Projected Whole Body Dose</u>	<u>Thyroid Dose</u>	<u>Authorized By</u>
1. Life Saving and Reduction of Injury	75 REM*	375 REM	(Interim) Emergency** Director
2. Operation of Equipment to Mitigate an Emergency	25 REM*	125 REM	(Interim) Emergency** Director
3. Protection of Health and Safety of the Public	5 REM	25 REM	(Interim) Emergency** Director
4. Other Emergency Activities	10 CFR 20 limits	10 CFR 20 limits	Emergency Director
5. Re-entry/Recovery Activities	Station Administrative Guidelines	Station Administrative Guidelines	N/A

* Reference: EPA-520/1-75-001 Table 2.1

** Such exposure shall be on a voluntary basis

PHILADELPHIA ELECTRIC COMPANY
LIMERICK GENERATING STATION
EMERGENCY PLAN IMPLEMENTING PROCEDURE*J. J. [Signature]* 7/20/64EP-231 OPERATION OF POST-ACCIDENT SAMPLING SYSTEMS (PASS)1.0 PURPOSE

The purpose of this procedure is to provide guidelines for obtaining samples from the Post-Accident Sampling Station following accident conditions.

2.0 RESPONSIBILITIES

- 2.1 The Chemistry Sampling and Analysis Group Leader shall direct the group members to perform the necessary steps in this procedure.

3.0 APPENDICES

- 3.1 EP-231-1 Procedure for Draining the Trap, Sump and Collector
- 3.2 EP-231-2 Procedure for Obtaining 14.4 ml Gas Sample
- 3.3 EP-231-3 Procedure for Obtaining Iodine/Particulate Sample
- 3.4 EP-231-4 Procedure for Obtaining a Small Volume Liquid Sample
- 3.5 EP-231-5 Procedure for Obtaining a Large Liquid Sample and/or a Dissolved Gas Sample
- 3.6 EP-231-6 Procedure for Flushing the Liquid and Dissolved Gas System
- 3.7 EP-231-7 M-102 General Arrangement Plan at El. 217'-0"
- 3.8 EP-231-8 Diagram of Control Panel-left side (Original Photographs are kept on file with Chemistry Supervision)

CONTROLLED

VALID ONLY WHEN RED

- 3.9 EP-231-9 Diagram of Control Panel-right side
(Original photographs are kept on file with Chemistry
Supervision)
- 3.10 EP-231-10 Control Panel Switch Layout
- 3.11 EP-231-11 Schematic of Post Accident Sample Station

4.0 PREREQUISITES

- 4.1 Prior to entering the plant to obtain the sample, ensure that the Post Accident Sample Station is operable by verifying that RT-5-030-800-0, POST ACCIDENT SAMPLE STATION OPERABILITY TEST, was successfully performed in the previous six months.

5.0 SPECIAL EQUIPMENT

- | 5.1 Gas vial sample tube
- | 5.2 Iodine & particulate sample assembly
- | 5.3 14.4 ml gas vials and caps
- | 5.4 Liquid sample bottles and caps
- | 5.5 10cc syringe with luer-lok fitting
- | 5.6 Silver zeolite cartridges
- | 5.7 47mm particulate filters (Gelman)
- | 5.8 Small bottle of demin water
- | 5.9 Large volume cask
- | 5.10 Small volume cask
- | 5.11 Gas sample cask
- | 5.12 Flashlight
- | 5.13 Mirror
- | 5.14 Watch with secondhand or stopwatch
- | 5.15 Plastic bags

- 5.16 PASS carrying box
- 5.17 Copy of EP-231-Operation of Post-Accident Sampling Systems (PASS)
- 5.18 Blank Data Sheets
- 5.19 Portable Communication Equipment (if available)
- 5.20 Clip Board
- 5.21 Pens, Pencils, etc.
- 5.22 Towels
- 5.23 Control Panel Power Key
- 5.24 Ramp for Large Volume Case
- 5.25 Scissors

6.0 SYMPTOMS

None

7.0 ACTION LEVEL

This procedure shall be implemented when a sample shall be taken from the PASS during an emergency situation.

8.0 PRECAUTIONS

- 8.1 Planned radiation exposures should be limited to the administrative guide levels in Appendix EP-230-1, Emergency Exposure Guidelines.
- 8.2 Continuous coverage by a health physics technician may substitute for the Radiation Work Permit.
- 8.3 Eye protection should be worn by all personnel when obtaining samples from the sample station.
- 8.4 There is no automatic drain or blow down but there is an alarm light to indicate that the level in the trap T-717 is high and that the trap needs to be drained right away. This trap removes water from the gas

sample lines. If the liquid level becomes too high, water will be sucked into the gas breakdown pump and mechanical damage may result.

- 8.5 Minimum amount of time should be spent near the surface of the sample enclosure.
- 8.6 The indicator for Area Radiation Detector RE-507 is on the control panel and its reading should be noted.
- 8.7 Prior to collecting a sample, (and after the system has been operated) the PASS should be drained and blown out in accordance with Appendix EP-231-1.

9.0 PROCEDURE

9.1 ACTIONS

- 9.1.1 The (Interim) Chemistry Sampling and Analysis Team Leader shall:
 - 9.1.1.1 After discussing the situation with the (Interim) Emergency Director, determine which of the following PASS samples are required based on the following information:

<u>Sample</u>	<u>Sampling Time</u>
1. Drywell Atmosphere	25 Min.
A. Upper Drywell 291' El	
B. Lower Drywell 242' El	
2. Suppression Pool Atmosphere	
A. 222' El-250 Deg Azimuth from North	
B. 222' El-70 Deg Azimuth from North	
3. Secondary Containment Atmosphere	10 Min.
4. Primary Coolant Jet Pump	20 Min.

5. RHR 25 Min.

A. "A" RHR

B. "B" RHR

- 9.1.1.2 Check the Plant Radiation Level Status Board to forecast anticipated radiological conditions.
- 9.1.1.3 Contact the Personnel Safety Team Leader and check on the latest developments related to radiological conditions and inform him what sample(s) are to be taken and that Health Physics' coverage is required.
- 9.1.1.4 Request input from the Control Room (via Emergency Director) to ascertain desired sample system availability.
- 9.1.1.5 Determine what analyses are required and inform the Chemistry Sampling and Analysis Group Leader what analyses are required. If an iodine/particulate sample is desired, recommend sampling time.
- 9.1.1.6 Request Emergency Exposure Authorizations from the Emergency Director for group members (as required) and inform the Personnel Safety Team Leader of this development.
- 9.1.1.7 Direct the Chemistry Sampling and Analysis Group Leader to collect and analyze the PASS samples.
- 9.1.2 The Chemistry Sampling and Analysis Group Leader shall:
- 9.1.2.1 Assign the appropriate number of group members to obtain the necessary equipment to collect and transport the sample to the hot chemistry lab.
- 9.1.2.2 If a particulate/iodine cartridge sample is to be obtained, contact the Chemistry Sampling and Analysis Team Leader (TSC) for an estimated sampling time and record this time on Appendix EP-231-3.

9.1.2.3 Once the sample type and sampling location has been determined, contact the Control Room and request a system line-up to permit collection of the appropriate sample in accordance with the following information. Also, inform operations to contact the Chemistry Sampling and Analysis Group Leader if problems with the line-up arise during sampling.

<u>SAMPLE LOCATION</u>	<u>SWITCH</u>	<u>SWITCH NAME</u>	<u>POSITION</u>
A. <u>Upper Drywell (291')</u> or <u>Lower Drywell (242')</u>	SV-57-132,134,150 -(232,234,250)	1 B Containment Atmosphere Sample Sys. Isolation	OPEN
	HS-57-153(253)	Drywell Atmosphere Sample Sys. Isolation	AUTO
	*HSS-57-191B(291B)	Containment Isolation Signal Bypass	BYPASS
	*HSS-57-191D(292D)	Containment Isolation Signal Bypass	BYPASS
B. <u>Suppression Pool(222')</u> (250 Deg Azimuth from North)	SV-57-183,191 -(283,291)	1 A Containment Atmosphere Sample Sys. Isolation	AUTO
	HS-57-187(287)	Suppression Pool Atmosphere Sample Sys. Isolation	AUTO
	*HSS-57-191A(291A)	Containment Isolation Signal Bypass	BYPASS
	*HSS-57-191C(291C)	Containment Isolation Signal Bypass	BYPASS

* Only necessary if containment isolation signal is present

<u>SAMPLE LOCATION</u>	<u>SWITCH</u>	<u>SWITCH NAME</u>	<u>POSITION</u>
C. <u>Suppression Pool (222')</u> (70 Deg Azimuth from North)	SV-57-181(281)	1 B Containment Atmosphere Sample Sys. Isolation	AUTO
	HS-57-187(287)	Suppression Pool Atmosphere Sample Sys. Isolation	AUTO
	*HSS-57-191B(291B)	Containment Isolation Signal Bypass	BYPASS
	*HSS-57-191C(291C)	Containment Isolation Signal Bypass	BYPASS
D. <u>Secondary Containment</u>		No Line-up Necessary	
E. <u>"A" RHR</u>	HV-51-1F079A (2F079A)	1 A RHR Sample Line Upstream Isolation Valve	OPEN
	HV-51-1F080A (2F080A)	1 A RHR Sample Line Outboard	OPEN
	*HSS-57-191A(291A)	Containment Isolation Signal Bypass	BYPASS
	*HSS-57-191B(291B)	Containment Isolation Signal Bypass	BYPASS

* Only necessary if containment isolation signal is present

<u>SAMPLE LOCATION</u>	<u>SWITCH</u>	<u>SWITCH NAME</u>	<u>POSITION</u>
F. <u>"B" RHR</u>	HV-51-1F079B (2F079B)	1 B RHR Line Upstream Isolation Valve	OPEN
	HV-51-1F080B (2F080B)	1B RHR Sample Line Downstream Isolation	OPEN
	*HSS-57-191A(291A)	Containment Isolation Signal Bypass	BYPASS
	*HSS-57-191B(291B)	Containment Isolation Signal Bypass	BYPASS

* Only necessary if containment isolation signal is present.

9.1.2.4 Have the shift verify that the liquid return line to the Suppression Pool is open by placing the following switch in the appropriate position:

<u>UNIT</u>	<u>SWITCH</u>	<u>SWITCH NAME</u>	<u>POSITION</u>
1	HS-52-101D	Supp Pool Suction	OPEN
2	HS-52-101A	Supp Pool Suction	OPEN

9.1.2.5 Appoint Group member(s) to prepare the Hot Lab for receiving the sample.

USE THE FOLLOWING PROCEDURES AS GUIDELINES FOR PREPARATION OF THE HOT LAB.

EP-241 (LIQUID)	Sample Preparation and Handling of Highly Radioactive Liquid Samples
EP-242 (IODINE)	Sample Preparation and Handling of Highly Radioactive Particulate Filters and Iodine Cartridges
EP-243 (GAS)	Sample Preparation and Handling of Highly Radioactive Gas Samples

- 9.1.2.6 If a large volume liquid sample is to be taken and an outside route is to be taken, contact the Fire and Damage Repair Team Leader for providing the means of transportation for the Large Volume Cask.
- 9.1.2.7 Brief the Chemistry Sampling and Analysis Group members on the following:
- A. Communications equipment and channel
 - B. Type of sample(s) to be collected
 - C. Location of sample points
 - D. Suggested Routes to be taken
 - E. Precautions for operating the PASS
 - F. Projected amount of time required to collect and transport the sample
 - G. Review the procedures to be followed for sample collection, handling, preparation and analysis
 - H. Special tools and equipment required for sample handling and/or collection
 - I. Proper completion of data sheets
- 9.1.2.8 Dispatch the Chemistry Sampling and Analysis Team members to the OSC for Health Physics support if radiological conditions permit or other appointed location as determined by the Plant Survey Group Leader.
- 9.1.3 The Health Physics Technician shall:
- 9.1.3.1 Determine the appropriate route to be taken.
 - 9.1.3.2 Take appropriate radiation survey equipment and ensure that equipment is functional and calibrated.
 - 9.1.3.3 Provide group members with the appropriate dosimetry, protective clothing and respiratory equipment.

- 9.1.3.4 Perform a pre-job briefing with the Chemistry technicians assigned to obtain the sample to discuss the following:
- A. RWP requirements
 - B. Routes to PASS Facility
 - C. Authorized doses
 - D. Radiological concerns and precautions
 - E. Review of procedure for obtaining and transporting sample to hot lab
 - F. Suggested methods to maintain exposures ALARA
 - G. Stay times and Abort Criteria
- 9.1.3.5 Provide constant coverage while obtaining and transporting samples from the PASS.
- 9.1.3.6 Monitor dose rates enroute and at the sample location. If the general area dose rates exceed 5 R/hr at the door leading to the Turbine Enclosure, 217'-0" El. or 10 R/hr within the Turbine enclosure (enroute to or at the sampling point) instruct Group Members to immediately exit the area and report to the Chemistry Sampling and Analysis Group Leader.
- 9.1.3.7 Survey the sample area (concentrating especially on the PASS) and the sample container once the sample has been collected and the shielded sample cask.
- 9.1.3.8 Document the sample cask survey results and give them to the Chemistry Sampling and Analysis Group Leader (or other designated group member) when arriving at the hot lab.
- 9.1.3.9 Provide constant coverage during sample preparation and handling as specified in EP-241, EP-242 or EP-243.
- 9.1.4 Chemistry Sampling and Analysis Group members shall:
- 9.1.4.1 Assemble for a pre-job briefing at the chemistry lab.

9.1.4.2 Inform the Group Leader if they are approaching the Administrative exposure guidelines, or may not have sufficient exposure remaining to successfully complete the assigned task.

9.1.4.3 Obtain the necessary equipment to collect the sample and ensure that the hot lab is ready to accept the sample.

PROPERLY LABEL ALL SAMPLE CONTAINERS

9.1.4.4 Once the group has been briefed and the appropriate equipment has been assembled proceed to the OSC or other designated location for Health Physics coverage. Once briefed by Health Physics collect the sample in accordance with the appropriate appendix to this procedure. (see following)

Appendix Title

EP-231-1 - Procedure for Draining the Trap, Sump and Collector

EP-231-2 - Procedure for Obtaining 14.4 ml Gas Sample

EP-231-3 - Procedure for Obtaining Iodine/Particulate Sample

EP-231-4 - Procedure for Obtaining a Small Volume Liquid Sample

EP-231-5 - Procedure for Obtaining a Large Liquid Sample and/or a Dissolved Gas Sample

EP-231-6 - Procedure for Flushing the Liquid and Dissolved Gas System

9.1.4.5 Once the H.P. technician has surveyed the sample cask, take the sample to the hot lab retracing the route back from the sample point.

9.1.4.6 Upon introduction of the sample into the hot lab, the sample will be handled and stored in a manner that personnel exposures are kept ALARA.

9.1.4.7 Contact the Group Leader as soon as the sample reaches the hot lab and inform him that the sample collection has been completed and what the sample status is.

9.2 FOLLOW-UP

9.2.1 Chemistry Sampling and Analysis Team Leader shall:

9.2.1.1 Report the results to the Emergency Director and the Health Physics and Chemistry Coordinator (EOF).

9.2.2 Chemistry Sampling and Analysis Group Leader shall:

9.2.2.1 Notify Shift Supervision that a sample has been taken and the aligned valves may be returned to the "NORMAL" position.

9.2.2.2 Have group member(s) dose monitored to ensure that exposure limits have not been exceeded.

9.2.2.3 Inform the Chemistry Sampling and Analysis Team Leader that the required sample is in the hot lab.

9.2.2.4 Instruct the group members to perform calculations (if any) on the Data Sheet of the appropriate Appendix.

9.2.2.5 Obtain pass key from Group member.

9.2.2.6 Instruct the appropriate group members to refer to the appropriate procedure for guidance on sample preparation and handling.

Sample

Procedure No.

Liquid (EP-241)

Sample Preparation and Handling of Highly Radioactive Liquid Samples

<u>Sample</u>	<u>Procedure No.</u>
Iodine (EP-242) (Particulate)	Sample Preparation and Handling of Highly Radioactive Particulate Filters and Iodine Cartridges
Gas (EP-243)	Sample Preparation and Handling of Highly Radioactive Gas Samples

9.2.2.7 Obtain and review ALL Data Sheets and report the sample results to the Chemistry Sampling and Analysis Team Leader and attach all Data Sheets to Appendix EP-230-2.

9.2.3 Chemistry Sampling and Analysis Group members shall:

9.2.3.1 Complete the appropriate Appendix Data Sheet(s) when applicable.

9.2.3.2 Prepare, handle, and analyze the sample using the appropriate procedure.

9.2.3.3 Report the results to the Chemistry Sampling and Analysis Group Leader.

9.2.3.4 Return all sampling equipment to the CHEMISTRY EMERGENCY CABINET.

10.0 REFERENCES

10.1 EP-230 - Chemistry Sampling and Analysis Team Activation

10.2 M-102 - General Arrangement Plan at El. 217'-0"

10.3 M-30, Rev. 3 - Post Accident Sampling P&ID

10.4 M-42, Proposed Rev. 34 - Nuclear Boiler Vessel Instrumentation

10.5 M-51, Sht. 1 - Rev. 31, Sht. 2 - Rev. 31, Residual Heat Removal P&ID

- 10.6 M-57- Sht. 1 - Proposed Rev. 33, Containment
Atmosphere Control P&ID
- 10.7 M1-D24-Z00 1, Vol. I & II, GEK83344, Operation and
Maintenance Instructions - PASS, Vol. I & II
- 10.8 A-107, Rev. 30, Architectural Floor Plan at Elevation
217'-0".

APPENDIX EP-231-1 *

PROCEDURE FOR DRAINING THE TRAP, SUMP AND COLLECTOR *

1. Ensure that the nitrogen supply valves are open and that the pressure is set at 100 psig by opening the following valves:

<u>N2 Bottle 1</u>	<u>Unit 1</u>	<u>Demin Water Tank</u>
PCV-30-074 30-0022	30-1114	30-0017
or	or	
<u>N2 Bottle 2</u>	<u>Unit 2</u>	
PCV-30-073 30-0023	30-2114	

2. Ensure that the Demineralized Flush Water Tank OOT 945 is full and is pressurized at 100 psig and the Valves (30-0014, 30-1100 (30-2100) are open to the sample station.

If not, open valves 30-0011 and 30-0015, verify that valve 30-0014 is open, remove the plug on the Hydro Test Tap by valve 30-0015, and SLOWLY open valve 30-0010. Continue flow until water appears at the test tap. Close valve 30-0010 FIRST, then close valves 30-0011 and 30-0015. Replace the Test Tap plug and secure.

3. Verify that the damper is open to Secondary Containment.
4. Check that FCV-627 is open and if it is not, use the knob adjacent to PCV-627 on the control panel to have a 15 psi reading on the gauge.

A GOOD WAY TO BE SURE THAT THE DISCHARGE LINE IS OPEN IS TO ESTABLISH A FLOW THRU FCV-627 BECAUSE THIS FLOW CAN BE OBSERVED AT THE CONTROL PANEL ON FLOW INDICATOR FI-664.

5. Turn all control panel switches "OFF" (except HC-723, place in position 4 "SPARE") and then TURN the Control Panel Power Selector Switch HC-600 to "A" (Alternate "B").
6. Drain Collector Tank, Trap and Sump by turning Switch HC-715-1 clockwise through its eight positions pausing approximately 5 seconds at each position.

* For multiple PASS samples, it is not necessary to perform Appendix EP-231-1 twice in a row.

APPENDIX EP-231-1

PROCEDURE FOR DRAINING THE TRAP, SUMP AND COLLECTOR (CONT)

7. Turn all switches (except for HC-723 which is left in position 4) to their "OFF" position. (Leave HC-600 in the ON position if more samples are to be taken).
8. If no more samples are to be taken, close nitrogen supply valves opened in Step No. 1.
9. Close FCV-627 by setting PCV-627 to 0 psig.
10. If no more samples are to be taken, close the damper to Secondary Containment.
11. If no more samples are to be taken, close the Demin Water Tank valves opened in Step No. 2.

APPENDIX EP-231-2

PROCEDURE FOR OBTAINING A 14.4 ML GAS SAMPLE

1. Drain the system per Appendix EP-231-1.
2. With the Drain System Switch (HC-715-1) in the "OFF" position, place Switch HC-700 (liquid/gas selector) in the "GAS" position. Ensure N2 bottle valves are open and regulated to approximately 100 psig. Ensure the Chiller E-703 is on. Quickly inspect the needle in the gas port to determine that its condition is satisfactory for obtaining a sample.
3. If a particulate/iodine sample will be obtained later, make sure that the desired filter cartridges are properly installed in the cartridge retainer. Install the gas filter drawer into position. Verify that the "CARTRIDGE IN" light is green.
4. Turn Switch HC-723 (GAS SAMPLE SELECTOR SWITCH) to the desired sample location:

<u>POSITION</u>	<u>LOCATION</u>
1	Drywell Atmosphere
2	Suppression Pool Atmosphere
3	Secondary Containment Atmosphere
4	Spare

5. Open the respective Reactor system valve in the gas sample line as follows:

<u>SAMPLE LOCATION</u>	<u>SWITCH</u>	<u>SWITCH NAME</u>	<u>POSITION</u>
* Upper Drywell ATM. (291')	HSS-57-146(246)	Sup Pool/Drywell Air To Post ACDT Samp	DRYWELL
* Lower Drywell ATM. (242')	HSS-57-147(247)	Sup Pool/Drywell Air To Post ACDT Samp	DRYWELL
* Suppression Pool ATM. (222') (250 Deg Azimuth from North)	HSS-57-147(247)	Sup Pool/Drywell ACDT Samp	SUPP POOL Air To Post
* Suppression Pool ATM. (222') (70 Deg Azimuth from North)	HSS-57-146(246)	Sup Pool/Drywell ACDT Samp	SUPP POOL Air To Post

Secondary Containment No Line-up Necessary
 ATM.

- * Verify that the light changes from green to red.

APPENDIX EP-231-2

PROCEDURE FOR OBTAINING A 14.4 ML GAS SAMPLE (CONT)

6. Place a standard 14.4 milliliter off gas vial into the gas vial positioner, slide the positioner into the gas port. Observe that the "Bottle In" status light changes from red to green. If the light does not change to green, reposition the bottle.
7. Turn the "15 ml Gas Sample Switch" HC-705 to position 2 and circulate gas for a period long enough to assure that the sample lines are flushed out with gas being sampled. The minimum time required is 5 minutes.

Be sure that the flow as read by the rotameter (FI-725) thru the sample enclosure window is in the expected range of 11.8 to 16.5 SLPM. Record flow and flush duration on data sheet.
8. Turn HC-705 to position 3 and evacuate the off gas vial. Record pressure PI-708 of the evacuated vial on the data sheet. Make sure the vacuum in the gas vial reaches a stable minimum reading.
9. Turn HC-705 to position 4, "TAKE SAMPLE". Verify that pressure (PI-708) does not change significantly. If the pressure changes significantly, it may indicate a system leak. Therefore, turn Switch HC-705 counter clockwise to position 2. Remove the sample vial and place in a plastic bag for transportation to the hot lab. Place a new 14.4 ml off gas sample vial into the gas positioner and return to Step 5.
10. Press the HC-720 button to obtain the sample. Keep button depressed until a steady pressure is reached (approximately 5 seconds). Record pressure from PI-708 on data sheet. This pressure should correspond to actual pressure of sample being obtained. Record sample temperature from TI-724 on data sheet.
11. Turn HC-705 to position 5 "FLUSH SYSTEM" and flush for approximately 1 minute.
12. Turn HC-705 clockwise to "OFF".
13. Turn Switch HSS-57-146 or HSS-57-147 (if opened in Step 4) to the CLOSE position.

APPENDIX EP-231-2

PROCEDURE FOR OBTAINING A 14.4 ML GAS SAMPLE (CONT)

- | 14. Wearing cotton liners and gloves, and observing ALARA practices, withdraw the gas vial positioner and immediately have the HP technician survey the gas sample vial and record the Initial Contact Dose Rate on the Data Sheet. Keep the vial at the maximum distance from the individual and quickly insert the sample bottle into the gas vial cask. Close and latch the gas vial cask. Put a stopper on the gas vial positioner back into the port in the sample station.
- | 15. Turn the Chiller E-703 off.
- | 16. Drain the system per Appendix EP-231-1.

APPENDIX EP-231-2

PROCEDURE FOR OBTAINING A 14.4 ML GAS SAMPLE (CONT)

Data Sheet for 14.4 ML Gas Sample

DESIRED ANALYSIS

- A. _____
- B. _____
- C. _____

1. Sample Source _____ Date _____ Time _____
2. Sample Flow _____ FI-725 (SLPM)
3. Flush Duration _____ (Min.)
4. Absolute Pressure of Vial _____ PI-708 (PSIA)
5. Final Sample Pressure _____ PI-708 (PSIA)
6. Sample Temperature _____ TI-724 (F)
7. Calculated Sample Volume _____ (ML)
$$V = \frac{(14.7)(14.4)(T F + 460)}{(530)(P \text{ PSIA})}$$
8. Initial Contact Dose Rate _____ (mR)

Name _____

APPENDIX EP-231-3

PROCEDURE FOR OBTAINING IODINE/PARTICULATE SAMPLE

1. Drain the system per Appendix EP-231-1
2. Verify that HC-715-1 DRAIN SYSTEM SWITCH is in the "OFF" position. Place Switch HC-700 (LIQUID/GAS SELECTOR) in the "GAS" position.
3. If the gas filter drawer is already in place and there is any doubt about the desired filters being in place, pull the drawer and check the filter cartridge(s). Put the desired filter cartridge(s) into the cartridge retainer, put the cartridge retainer into the gas filter drawer and put the drawer into the sample station and verify that the "CARTRIDGE IN" light is green. If not, reposition the drawer.
4. Decide whether a timed or non-timed sample is desired and record. Generally speaking, if a high activity condition exists or is suspected, a timed sample should be taken. For a timed sample, set the Timer KC-712 between the range of 0 to 30 seconds. Select a low enough time so that the activity on the filter cartridge will not be unnecessarily high and cause special handling problems. Observe the RI-704 reading to determine if there is a rapid activity buildup. Set the Switch HC-704 located to the left of the timer labeled TIME SAMPLE on either YES or NO.
5. Check that the nitrogen supply system is operating with pressure at 100 psig.
6. Ensure the Chiller E-703 is ON.
7. Turn the GAS SAMPLE SELECTOR SWITCH (HC-723) to the desired sample source.

<u>SAMPLE SOURCE</u>	<u>POSITION</u>
Drywell Atmosphere	1
Suppression Pool Atmosphere	2
Secondary Containment Atmosphere	3
Spare	4

APPENDIX EP-231-3

PROCEDURE FOR OBTAINING IODINE/PARTICULATE SAMPLE (CONT)

8. Open the respective Reactor system valve in the gas sample line for the appropriate sample as follows:

<u>SAMPLE LOCATION</u>	<u>SWITCH</u>	<u>SWITCH NAME</u>	<u>POSITION</u>
* Upper Drywell ATM. (291')	HSS-57-146(246)	Sup Pool/Drywell Air To Post ACDT Samp	DRYWELL
* Lower Drywell ATM. (242')	HSS-57-147(247)	Sup Pool/Drywell Air To Post ACDT Samp	DRYWELL
* Suppression Pool ATM. (222') (250 Deg Azimuth from North)	HSS-57-147(247)	Sup Pool/Drywell ACDT Samp	SUPP POOL Air To Post
* Suppression Pool ATM. (222') (70 Deg Azimuth from North)	HSS-57-146(246)	Sup Pool/Drywell ACDT Samp	SUPP POOL Air To Post

Secondary Containment No Line-up Necessary
 ATM.

- * Verify that the light changes from green to red.

9. Turn the IODINE CARTRIDGE SAMPLE SWITCH HC-712 to position 2 and circulate gas for a period long enough to assure that the sample lines are flushed out with the gas being sampled. Minimum flush time is approximately 5 minutes. Record the flush time on the data sheet.

10. Be sure the flow as read by the rotometer which is visible thru the window in the sample station enclosure is in the expected range of 11.8 to 16.5 slpm. Record the flow (FI-725), temperature (TI-724) and pressure (PI-726 and PI-727) on the data sheet. The two pressure gages (PI-726 and PI-727), as read thru the window, should be the same.

STEPS 10 AND 11 MUST BE DONE IN CONJUNCTION WITH EACH OTHER

11. Turn HC-712 to position 3. The sample gas will start to flow through the filter cartridge. On the DATA SHEET record PI-727, PI-726, FI-725, the flow duration in seconds and RI-704.

APPENDIX EP-231-3

PROCEDURE FOR OBTAINING IODINE/PARTICULATE SAMPLE (CONT)

- | 12. After the timer has timed out for a timed sample or after the predetermined time has elapsed for a non-timed sample, turn Selector Switch HC-712 to position 4 for 10 seconds to evacuate the filter cartridge. A vacuum will be quickly drawn on the system.
- | 13. Turn Switch HC-712 to position 5 which will admit a nitrogen flush through the filter cartridge to remove Krypton and Xenon gases. This purge should last approximately 20 seconds or until RI-704 is stable. Record the final radiation, RI-704.
- | 14. Rotate HC-712 clockwise to the "OFF" position. Turn other switches (except HC-600) to the "OFF" positions. Remove cartridge retainer and immediately survey the cartridge retainer and record the Initial Contact Dose Rate on the Data Sheet and put the cartridge retainer in a plastic bag. Tape bags closed. If available, install a new cartridge retainer complete with filter paper and iodine cartridges. Put drawer back into sample enclosure. Place the sample into a transport cask.
- | 15. Turn Switch HSS-57-146 or HSS-57-147 opened in Step 7 to the CLOSE position.
- | 16. Turn the Chiller E-703 off.
- | 17. Drain the system per Appendix EP-231-1.

APPENDIX EP-231-3

PROCEDURE FOR OBTAINING IODINE/PARTICULATE SAMPLE (CONT)

Data Sheet for Iodine/Particulate Sample

DESIRED ANALYSIS

A. _____

B. _____

ESTIMATED SAMPLING TIME _____

1. Sample Source _____ Date _____ Time _____
2. Orifice Size _____ 3.0 _____
3. Timed Sample Yes or No _____
4. Flush Time in Minutes _____
5. Sample Flow _____ FI-725 (not thru cartridge) (slpm)
6. Temperature _____ TI-724 (F)
7. Pressure _____ PI-726 (PSIG)
8. Pressure _____ PI 727 (PSIG)
9. Pressure _____ PI-726 (critical flow thru cartridge) (PSIG)
10. Pressure _____ PI-727 (PSIG)
11. Flow _____ FI-725 (scfh)
12. Flow Duration _____ seconds
13. Radiation _____ RI-704 (mR/hr)
14. Final Radiation _____ RI-704 (mr/hr)
15. Initial Contact Dose Rate _____ (mR)

NOTE: When critical flow is obtained through the cartridge assembly, a flow of 3.0 liters per minute +15% is achieved. This is true as long as PI-727 is at a minimum of 12 inches mercury vacuum.

Name _____

APPENDIX EP-231-4

PROCEDURE FOR OBTAINING A SMALL VOLUME LIQUID SAMPLE

IF A SAMPLE IS TO BE OBTAINED FROM THE JET PUMP (JET PUMP 4 SENSING LINE), THERE EXISTS THE POSSIBILITY OF EXCESS FLOW CHECK VALVE XV-42-1F059H TRIPPING WHICH WILL REQUIRE MANUAL RESETTING BY OPERATIONS. THE ALARMS ARE LOCATED ON LOCAL PANEL 10C228 (20C228) AND MAIN CONTROL BOARD ANNUNCIATOR 1BC802-35 (2BC802-35) (EXCESS FLOW CHECK VALVE OPERATED PANEL C228). IF AT ANY TIME WHILE SAMPLING AN INDICATION OF DECREASING FLOW (FCV627 on FI-664) AND/OR DECREASING PRESSURE (PI661) IS NOTICED, CONTACT THE CONTROL ROOM AND REQUEST MONITORING OF THESE ANNUNCIATORS.

1. Drain the system per Appendix EP-231-1.
2. Load the syringe with 10cc of demineralized water. Place the stopcock on the syringe and load the assembly onto the injection port.
3. Remove lead stopper and carrying handle from the small cask by unscrewing it and lifting it out. Leave stopper near by.
4. Make certain the lead shielding drawer is out so that the needles under the sample station enclosure are exposed. Quickly inspect the needles with a mirror and flashlight. Check that the shaft of the needle is towards the center of the sample vial.
5. Put a wide mouth liquid sample bottle with an outer aluminum retainer ring and septum into the small volume cask. Check that the bottle lifting lever is free to move up and down. The bottle must fit snugly in the holder and be vertically aligned. If the bottle does not fit snugly, use a small pad of rubber or felt, thick enough to hold vial against the upper yoke of the vial holder and/or attach the bottle to the vial holder with Velco tape.
6. Check that the small volume cask is in the cask positioner, and that both are hanging from the hooks below the sample station.

CAUTION: THE LEAD SHIELDING DRAWER WEIGHS APPROXIMATELY 70 POUNDS.

APPENDIX EP-231-4
PROCEDURE FOR OBTAINING A SMALL VOLUME LIQUID SAMPLE (CONT)

7. Swing the cask into position under the sample station and lock the arms of the cask holder so the cask and bottle will remain in position.
8. Close PCV-627 by turning counterclockwise.
9. To check the fit and operation of the sample vial without bringing a hot sample into the system, turn HC-616-1 SMALL VOLUME SAMPLE switch to position 3 (FLUSH LOOP).
10. With control panel power on and all other switches in the up and "OFF" position, set Switch HC-700 to the "LIQUID" position and Liquid Sample Selector Switch HC-626 to position 2 (Jet Pump Line) if a jet pump sample is desired or to position 4 (RPV or Suppression Pool) if the Reactor valves were set for a RHR sample. Adjust PCV-627 so that the flow thru PCV-627 does not exceed 1 gpm (See FI-664).

Also, if a RHR sample is desired, close the normal RHR sample lines by placing the respective switch in the following position:

<u>SAMPLE LOCATION</u>	<u>SWITCH</u>	<u>SWITCH NAME</u>	<u>POSITION</u>
"A" RHR	HS-51-199A(299A)	RHR Hx Normal Sample ISLN Loop A	CLOSE
"B" RHR	HS-51-199B(299B)	RHR Hx Normal Sample ISLN Loop B	CLOSE

11. Raise the sample bottle into position on the needles by moving the lift rod on the side of the cask.
12. Screw the lift rod in to hold the sample bottle in the engaged position. Note: If the vial does not clear the entry hole, lower the vial and rotate the small volume cask about 1/8" in either direction. If it still does not fit either the liquid vial positioner fixture or liquid tray positioner needs adjustment. Note: The green light for the small volume sample should be on. If the light remains red, unscrew the lift rod, lower the bottle and reposition.
13. Turn HC-616-1 to the OFF position.

APPENDIX EP-231-4
PROCEDURE FOR OBTAINING A SMALL VOLUME LIQUID SAMPLE (CONT)

- | 14. Turn Liquid Sample Selector Switch HC-626 to position 1 (Jet Pump Line on Bypass) for a sample from the jet pump line or to position 5 (RPV or Sup'n Pool on Bypass) for a sample from the RHR line. Adjust PCV-627 so that the flow thru FCV-627 does not exceed 1 gpm. (See FI-664) Continue this flow thru bypass valve CV-626 for a long enough period to be assured that the sample lines are flushed. The minimum time required to do this is 7 minutes. Record the flow and flush time on the data sheet.
- | 15. After flush is completed, turn Switch HC-626 to position 2 (for jet pump sample) or position 4 (for RHR sample). Note that the flow on Indicator FI-664 is greatly reduced. Adjust Valve FCV-627 for a flow of 0.3 gpm, using PCV-627 (see FI-664).
- | 16. Record the following on the data sheet:
 - Flow (FI-664)
 - Pressure (PI-661)
 - Temperature (TI-660)
 - Conductivity (CI-663)
 - Radiation (RI-665)
- | 17. Turn Small Volume Liquid Selector HC-616-1 to "TAKE SAMPLE" position (position 1). Valve CV-616 will rotate and carry the sample into alignment with the line to the sample bottle. Wait for Valve CV-616 light to come on.
- | 18. Open both stopcocks on the syringe and inject 10cc of water into the line. Close the syringe stopcock. Remove the syringe and fill it with air. Reattach the syringe, open the stopcock and inject the air, then close the stopcock and remove the syringe.
- | 19. Unscrew the lift rod and lower the sample bottle.
- | 20. Turn the Switch HC-616-1 (small volume sample sw) to the FLUSH LOOP position (3). Make sure there is enough flow by adjusting PCV-627 so that it is set to at least 15 psig (see FI-664). Flush for 5 minutes and/or until RI-665 reaches a minimum.
- | 21. When the flush is complete, turn HC-626 (Liquid Sample Source Selector Switch) "OFF" FIRST and then HC-616-1 to "OFF" (position 2).
- | 22. Verify Switch HS-51-199A(299A) or HS-51-199B(299B) is in the CLOSE position.

APPENDIX EP-231-4
PROCEDURE FOR OBTAINING A SMALL VOLUME LIQUID SAMPLE (CONT)

- | 23. Unlock the arms of the cask holder and swing the cask out.
- | 24. Slide the lead shield drawer back into the enclosure to cover the opening for the needles and immediately survey the vial and replace the lead stopper.
- | 25. Transport the sample to the Hot Lab by removing both the positioner and cask and transporting together or if only the cask is desired, unscrew the lift rod out and transport only the cask.
- | 26. Drain the system per Appendix EP-231-1.

APPENDIX EP-231-4
PROCEDURE FOR OBTAINING A SMALL VOLUME LIQUID SAMPLE (CONT)

Data Sheet for Small Volume Liquid Sample

DESIRED ANALYSIS

- A. _____
- B. _____
- C. _____
- D. _____
- E. _____

1. Sample Source _____ Date _____ Time _____
2. Bypass Flow _____ FI-664 (gpm)
3. Flush Time _____ Minutes
4. Sample Flow _____ FI-664 (gpm)
5. Pressure _____ PI-661 (psig)
6. Temperature _____ TI-660 (F)
7. Conductivity _____ Scale _____ CI-663
8. Radiation _____ RI-665 (mR/hr)
9. Initial Contact Dose Rate _____ (mR)

Name _____

APPENDIX EP-231-5

PROCEDURE FOR OBTAINING A LARGE VOLUME LIQUID SAMPLE

AND/OR A DISSOLVED GAS SAMPLE

IF A SAMPLE IS TO BE OBTAINED FROM THE JET PUMP (JET PUMP 4 SENSING LINE), THERE EXISTS THE POSSIBILITY OF EXCESS FLOW CHECK VALVE XV-42-1F059H TRIPPING WHICH WILL REQUIRE MANUAL RESETTING BY OPERATIONS. THE ALARMS ARE LOCATED ON LOCAL PANEL 10C228 AND MAIN CONTROL BOARD ANNUNCIATOR 1BC802-35 (EXCESS FLOW CHECK VALVE OPERATED PANEL C228). IF AT ANY TIME WHILE SAMPLING AN INDICATION OF DECREASING FLOW (FCV627 on FI-664) AND/OR DECREASING PRESSURE (PI661) IS NOTICED, CONTACT THE CONTROL ROOM AND REQUEST MONITORING OF THESE ANNUNCIATORS.

1. Drain the system per Appendix EP-231-1.
2. If a dissolved gas sample is to be taken open the tracer gas bottle valve and regulate to 2-3 psig. Record pressure. Also, open the Krypton supply valve 30-1113(-2113).
3. Make certain the lead shield drawer is out so that the needles under the sample station enclosure are exposed. Quickly inspect the needles with a mirror and flashlight. Check that the longest part of the needle is toward the center of the sample vial.
4. Remove lead stopper from large volume cask and put a 15 ML sample bottle with an outer aluminum retainer ring and a neoprene cap into the large cask. Note sample bottle must fit snugly in the holder and be vertically aligned. If necessary, place small pad under sample vial and/or attach the vial to the holder with Velco Tape. With cask in fully lowered position, roll cask into position under the sample station.
5. Close PCV-627 by turning counterclockwise.
6. Using the hydraulic pump slowly raise the cask, checking for proper alignment. Stop pumping when top cask ring is inside and the large volume cask is just below the bottom of the sample station.
7. To check the fit and operation of the sample vial without bringing a hot sample into the system, turn HC-616-1 SMALL VOLUME SAMPLE switch to position 3 (FLUSH LOOP).

APPENDIX EP-231-5

PROCEDURE FOR OBTAINING A LARGE VOLUME LIQUID SAMPLE
AND/OR A DISSOLVED GAS SAMPLE (CONT)

- | 8. Place the gas vial in the holder and insert into the dissolved gas sample point.
- | 9. With control panel power on and all other switches in the up and "OFF" position, set Switch HC-700 to the liquid position, and Liquid Sample Selector Switch HC-626 to position 2 if a jet pump sample is desired or to position 4 if the Reactor valves were set for a RHR sample. Adjust PCV-627 so that the flow thru FCV-627 does not exceed 1 gpm (see FI-664). Note that the dissolved gas sample light turns green. If it does not, readjust the vial position.
- | 10. Push the plunger down which causes the sample bottle to be raised out of the cask and up onto the two needles. Note that the "bottle in" light will change from red to green. If the cask is not aligned properly, lower bottle and reposition cask.
- | 11. Make certain that HC-616-1 (Small Volume Sample Switch) is in the "OFF" position.
- | 12. Turn the Liquid Sample Source Selector Switch HC-626 to position 1 for jet pump bypass line sample or 5 for RHR sample.

If RHR sample is desired, close the sample line valves to the normal sample station:

<u>SAMPLE LOCATION</u>	<u>SWITCH</u>	<u>POSITION</u>
"A" RHR	HS-51-199A(299A)	CLOSE
"B" RHR	HS-51-199B(299B)	CLOSE

- | 13. FI-664 on control panel should be approximately 1 gpm. PI-661, TI-660, CI-663 and RI-665 should start to have meaningful values.
- | 14. Adjust PCV-627 so that the flow on FI-664 does not exceed 1 gpm. Continue this flow for a long enough period (at least 7 minutes) to be assured that the sample lines are flushed out with liquid being sampled.

RECORD THE FLOW FROM FI-664 AND FLUSH TIME ON DATA SHEET.

- | 15. When flush is completed, turn HC-626 Sample Source Selector Switch to position 2 for a jet pump sample or position 4 if

APPENDIX EP-231-5

PROCEDURE FOR OBTAINING A LARGE VOLUME LIQUID SAMPLE
AND/OR A DISSOLVED GAS SAMPLE (CONT)

Reactor valves were positioned for a RHR sample. Adjust FCV-627 for a flow of 0.3 gpm (see FI-664).

16. Turn the Dissolved Gas and Liquid Sample System Switch HC-601 to position 1 and observe that P-701 starts and Valve CV-622 rotates.
17. Turn Switch HC-601 to position 2. Observe that P-601 starts.
18. Record the following on the data sheet:
 - Flow (FI-664)
 - Pressure (PI-661)
 - Temperature (TI-660)
 - Conductivity (CI-663)
 - Radiation (RI-665)
19. Turn Switch HC-601 to position 3 to isolate the sample and start the dissolved gas separator. Leave in this position for approximately 10 seconds.
20. IF IT IS NOT DESIRABLE TO INTRODUCE TRACER GAS, TURN HC-601 TO POSITION 5 QUICKLY AND VALVE WILL NOT ROTATE. PROCEED TO STEP 25.
21. Turn HC-601 to position 4 to inject tracer gas into valve CV-615. When the valve is rotated during the next step the tracer gas trapped in the passage of the ball valve will be inserted in the sample flow loop. Leave in this position for approximately 10 seconds. Read and record the tracer gas supply system pressure so tracer gas can be accurately calculated. The flow of tracer gas should be very small so that pressure drops in the line and valves will be insignificant.
22. Turn HC-601 to position 5. Let some of the dissolved gas separate from the liquid.
23. Read and record initial pressure PI-662 as P-O.
"NOTE" STEPS 24, 25 AND 26 REQUIRE PROPER TIMING
24. Turn HC-601 to position 6 for no more than 5 seconds.

APPENDIX EP-231-5

PROCEDURE FOR OBTAINING A LARGE VOLUME LIQUID SAMPLE
AND/OR A DISSOLVED GAS SAMPLE (CONT)

- | 25. Turn HC-601 to position 7 for 10 seconds and record the pressure (from PI-662) as P-1.
- | 26. Turn HC-601 to position 8 for no more than 5 seconds.
- | 27. Turn HC-601 to position 9 to get ready to take the dissolved gas sample or to relieve the collection chamber pressure. Pump P-601 will stop so that if the relieve pressure option is next exercised record PI-662 as P2 on data sheet as this is the pressure of the liquid sample loop.
- | 28. Dissolved gas sample?
YES PROCEED TO STEP 29
NO PROCEED TO STEP 30
- | 29. To take the dissolved gas sample, Switch HC-652 will be used. When HC-652 is turned clockwise to gas sample, the pressure as indicated by PI-662 will decrease while the dissolved gas is drawn into sample bottle. Turn HC-652 to gas sample and hold for at least 10 seconds until PI-662 is very steady. Release HC-652. Turn HC-652 again to gas sample. Verify equalized pressure and read PI-662. Release HC-652. Record the steady pressure as P3 reading on the data sheet. Proceed to Step 34.
- | 30. As an alternate to Step 28, when a dissolved gas sample is not desired, it is only necessary to relieve the gas pressure back to the suppression pool by rotating Switch HC-652 counter clockwise to relieve pressure position and hold it while watching PI-662. The pressure will equalize rapidly.
- | 31. Large Volume Sample?
YES PROCEED TO STEP 32
NO PROCEED TO STEP 33
- | 32. If a large volume liquid sample is desired, turn HC-601 to position 10. HC-629-1 must be pushed and held for 10 seconds for liquid to be drawn into the sample bottle. Proceed to Step 37.
- | 33. If a large liquid sample is not desired, turn Switch HC-601 to the "OFF" position very quickly so that Valve CV-620 will not rotate and no radioactive liquid will be in the line ahead of CV-629.

APPENDIX EP-231-5

PROCEDURE FOR OBTAINING A LARGE VOLUME LIQUID SAMPLE
AND/OR A DISSOLVED GAS SAMPLE (CONT)

- | 34. Turn HC-601 to "OFF".
- | 35. Lower liquid sample bottle into large cask by pulling up on the plunger handle. Note: Do not turn or twist bottle while it is on the needles because the needles will bend.
- | 36. Lower the cask on the cart by relieving hydraulic oil pressure with the small petcock handle on the hydraulic cylinder.
- | 37. Slide the lead shield drawer back into the enclosure to cover opening for the needles.
- | 38. Roll the cask out from under the sample station and immediately survey the liquid vial and record the Initial Contact Dose Rate on the Data Sheet. Quickly plug cask. Use RI-665 to determine Gross Activity of the sample.
- | 39. Open and place gas vial carrying cask near sample station. Remove gas vial positioner from sample enclosure and immediately survey the gas vial and record the Initial Contact Dose Rate on the Data Sheet. Keep the vial at maximum distance from the individual and insert sample bottle into the gas vial cask. Close and latch the gas vial cask.
- | 40. Perform a flush of the liquid system with Switch HC-628-1 per Appendix EP-231-6.

APPENDIX EP-231-5

PROCEDURE FOR OBTAINING A LARGE VOLUME LIQUID SAMPLE
AND/OR A DISSOLVED GAS SAMPLE (CONT)

DATA SHEET

DESIRED ANALYSIS

- A. _____
- B. _____
- C. _____
- D. _____
- E. _____

1. Sample Source _____ Date _____ Time _____
2. Krypton Tracer Gas Pressure _____ psig
3. Bypass Flow _____ FI-664 gpm
4. Flush Time _____ Minutes
5. Sample Flow _____ FI-664 gpm
6. Pressure _____ PI-661 psig
7. Temperature _____ TI-660
8. Conductivity Meter _____ Scale _____ CI-663
9. Radiation _____ RI-665
10. Tracer Gas Supply System Pressure _____ psig
11. Initial Pressure P-O _____ PI-662
12. Pressure P-1 _____ PI-662
13. Stabilized Pressure P2 _____ PI-662
14. Sample Pressure P3 _____ PI-662
15. Initial Contact Dose Rate _____ (mR) Liquid Vial.
16. Initial Contact Dose Rate _____ (mR) Gas Vial.

APPENDIX EP-231-5

PROCEDURE FOR OBTAINING A LARGE VOLUME LIQUID SAMPLE
AND/OR A DISSOLVED GAS SAMPLE (CONT)

DATA SHEET (CONT)

16. V1 H2 (From GC) _____ ml

17. V2 O2 (from GC) _____ ml

18. V2 Kr (from GC) _____ ml

19. Vol % O2 _____ %

$$\text{Vol \% O2} = \frac{V2 \text{ O2} - .2P-o}{17317} \times \frac{Kr}{V2 Kr} (P-o + 14.7)$$

20. Vol % H2 _____ %

$$\text{Vol \% H2} = \frac{V1 \text{ H2}}{17317} \times \frac{Kr}{V2 Kr} (P-o + 14.7)$$

Name _____

APPENDIX EP-231-6

PROCEDURE FOR FLUSHING THE LIQUID AND DISSOLVED GAS SYSTEM

1. Verify that the nitrogen supply is still on and the pressure is regulated to 100 psig.
2. Verify that the demin water tank is adequately filled and pressurized to 100 psig.
3. Make sure that FCV-627 is open by adjusting PCV-627 to 15 psig.
NEVER EXCEED 1 GPM ON FI-664
4. Switch HC-626 (Liquid Sample Source Selector Switch) must be in position 2 (jet pump) or 4 (RHR) and HC-700 (Liquid or Gas Selector Switch) must be in the LIQUID position.
5. Turn the FLUSH SYSTEM SWITCH (HC-628-1) to position 2 (Start Flush) which will close the inlet sample lines and start the flush with demineralized water from 00T 945. Observe that there is a flow per FI-664.
6. After RI-665 shows radiation has decreased significantly, or after 5 minutes, turn Switch HC-628-1 to position 3 (Flush V-610 Loop) to flush the V-610 loop. Watch RI-665.
7. After a few minutes, turn Switch HC-628-1 to position 4 (Flush P-601 Loop) and flush the P-601 loop. Watch RI-665.
8. After a few minutes, turn Switch HC-628-1 to position 5 (Flush CV-615) and flush Valve CV-615. Watch RI-665.
9. After a few minutes, turn Switch HC-628-1 to position 6 (Flush Piping Station) and flush the piping station for 3 minutes.
10. Turn Switch HC-628-1 to position 7 (Flush CV-622 Loop) for a few minutes to flush loop CV-622. Watch RI-665.
11. Turn HC-626 to "OFF" FIRST and then HC-628-1 to "OFF".
12. If RI-665 did not indicate an acceptable radiation level at any step of the operation, go back and repeat Steps 4 thru 11.
13. Drain the system per Appendix EP-231-1.

APPENDIX EP-231-7

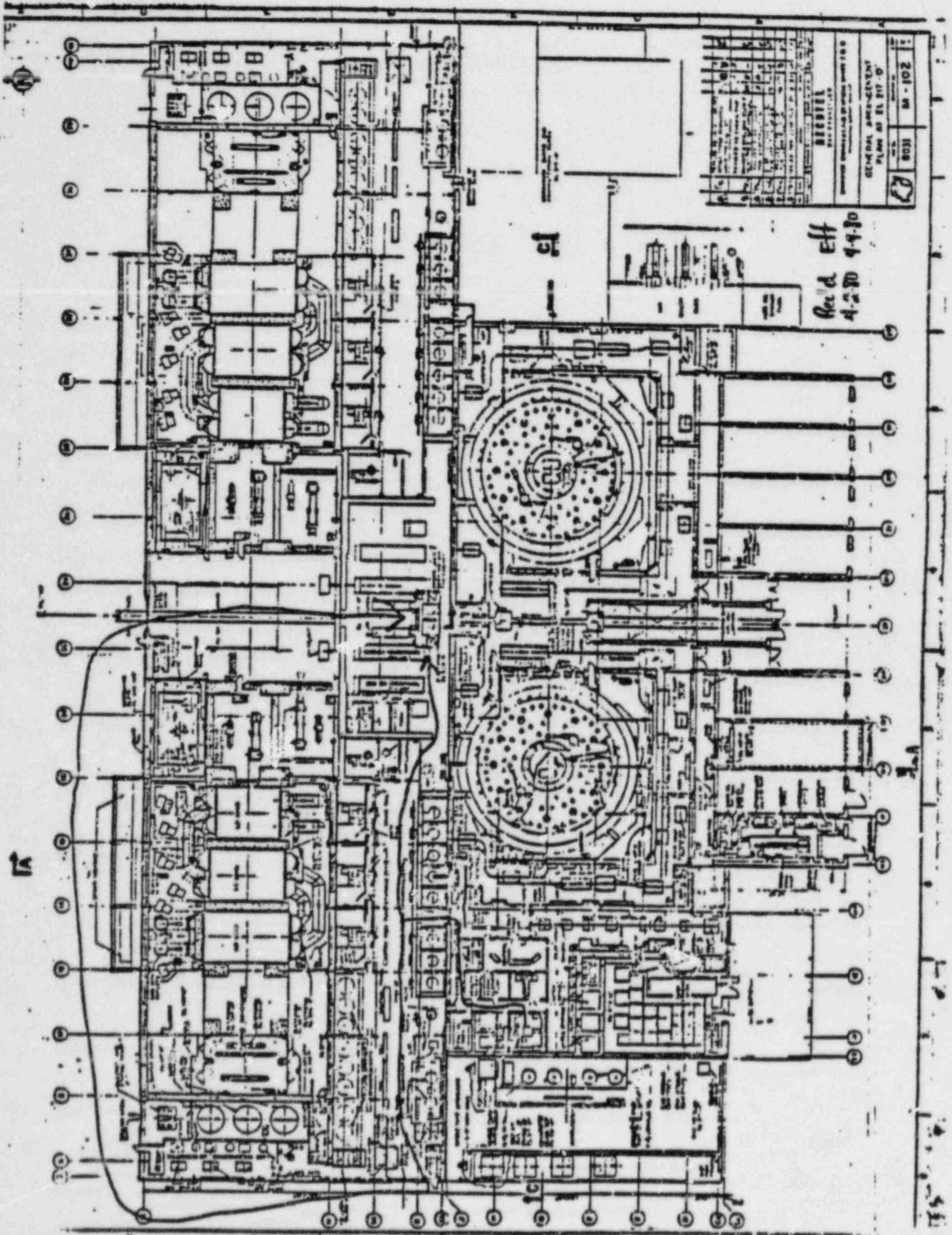

REVISIONS	
NO.	DESCRIPTION
1	ISSUED FOR PERMIT
2	ISSUED FOR PERMIT
3	ISSUED FOR PERMIT
4	ISSUED FOR PERMIT
5	ISSUED FOR PERMIT
6	ISSUED FOR PERMIT
7	ISSUED FOR PERMIT
8	ISSUED FOR PERMIT
9	ISSUED FOR PERMIT
10	ISSUED FOR PERMIT
11	ISSUED FOR PERMIT
12	ISSUED FOR PERMIT
13	ISSUED FOR PERMIT
14	ISSUED FOR PERMIT
15	ISSUED FOR PERMIT
16	ISSUED FOR PERMIT
17	ISSUED FOR PERMIT
18	ISSUED FOR PERMIT
19	ISSUED FOR PERMIT
20	ISSUED FOR PERMIT
21	ISSUED FOR PERMIT
22	ISSUED FOR PERMIT
23	ISSUED FOR PERMIT
24	ISSUED FOR PERMIT
25	ISSUED FOR PERMIT
26	ISSUED FOR PERMIT
27	ISSUED FOR PERMIT
28	ISSUED FOR PERMIT
29	ISSUED FOR PERMIT
30	ISSUED FOR PERMIT
31	ISSUED FOR PERMIT
32	ISSUED FOR PERMIT
33	ISSUED FOR PERMIT
34	ISSUED FOR PERMIT
35	ISSUED FOR PERMIT
36	ISSUED FOR PERMIT
37	ISSUED FOR PERMIT
38	ISSUED FOR PERMIT
39	ISSUED FOR PERMIT
40	ISSUED FOR PERMIT
41	ISSUED FOR PERMIT
42	ISSUED FOR PERMIT
43	ISSUED FOR PERMIT
44	ISSUED FOR PERMIT
45	ISSUED FOR PERMIT
46	ISSUED FOR PERMIT
47	ISSUED FOR PERMIT
48	ISSUED FOR PERMIT
49	ISSUED FOR PERMIT
50	ISSUED FOR PERMIT
51	ISSUED FOR PERMIT
52	ISSUED FOR PERMIT
53	ISSUED FOR PERMIT
54	ISSUED FOR PERMIT
55	ISSUED FOR PERMIT
56	ISSUED FOR PERMIT
57	ISSUED FOR PERMIT
58	ISSUED FOR PERMIT
59	ISSUED FOR PERMIT
60	ISSUED FOR PERMIT
61	ISSUED FOR PERMIT
62	ISSUED FOR PERMIT
63	ISSUED FOR PERMIT
64	ISSUED FOR PERMIT
65	ISSUED FOR PERMIT
66	ISSUED FOR PERMIT
67	ISSUED FOR PERMIT
68	ISSUED FOR PERMIT
69	ISSUED FOR PERMIT
70	ISSUED FOR PERMIT
71	ISSUED FOR PERMIT
72	ISSUED FOR PERMIT
73	ISSUED FOR PERMIT
74	ISSUED FOR PERMIT
75	ISSUED FOR PERMIT
76	ISSUED FOR PERMIT
77	ISSUED FOR PERMIT
78	ISSUED FOR PERMIT
79	ISSUED FOR PERMIT
80	ISSUED FOR PERMIT
81	ISSUED FOR PERMIT
82	ISSUED FOR PERMIT
83	ISSUED FOR PERMIT
84	ISSUED FOR PERMIT
85	ISSUED FOR PERMIT
86	ISSUED FOR PERMIT
87	ISSUED FOR PERMIT
88	ISSUED FOR PERMIT
89	ISSUED FOR PERMIT
90	ISSUED FOR PERMIT
91	ISSUED FOR PERMIT
92	ISSUED FOR PERMIT
93	ISSUED FOR PERMIT
94	ISSUED FOR PERMIT
95	ISSUED FOR PERMIT
96	ISSUED FOR PERMIT
97	ISSUED FOR PERMIT
98	ISSUED FOR PERMIT
99	ISSUED FOR PERMIT
100	ISSUED FOR PERMIT

Rec'd Eff
4-20-99

1/2" = 1'-0"

LIQUID
 PRESSURE
 PSIG PI-661



DISSOLVED
 GAS & PRESSURE
 PSIA PI-662

SAMPLE
 GAS & PRESSURE
 PSIA PS-708

SAMPLE
 RETURN FLOW
 GPM PJ-664

LIQUID OF
 SAMPLE
 TEMP. TI-660

GAS SAMPLE
 TEMP. TI-724
 OF

 
 PCV-627 FLOW CONTROL



 HC-715-1 DRAIN
 SYSTEM SWITCH

OFF ON
 KEY

STATUS LIGHTS
 Pilot Running
 Pilot Warning
 Pilot Warning
 OT-717 Trip High Loss

 HC-626 LIQ. SAMPLE
 SERVICE SELECTOR SWITCH

LIQ OFF GAS
 KEY

 HC-703 GAS SAMPLE
 SELECTOR SWITCH

Drywell AT1
 Suppression Pool AT11
 2nd Cont. AT11
 SPARE



 BOTTLE IN
 YES NO

HC-616-1 SMALL
 VOLUME SAMPLE SWITCH

 BOTTLE IN
 YES NO

 PREP TO SWIPE
 HC-705-15 IN
 GAS SAMPLE SWITCH



BOTTLE YES/NO ON/OFF LIQUID BOTTLE

 HC-601 DISSOLVED GAS & LIQ.
 SAMPLE SWITCH

CARTIDGE IN
 YES NO

 YES NO

 HC-702 I-2 CART.
 SAMPLE SWITCH

 
 DRYWELL Press. OFF/ON
 PREP FOR SAMPLE



 HC-628-1
 Flush
 System
 Switch

Red Green

 RHR HX
 Outlet Normal
 Sample ISLN
 LOOP B

 HV-51-199A

 KC-712
 CARTIDGE
 SAMPLE
 TELLER

Red Green

 RHR HX
 Outlet Normal
 Sample ISLN
 LOOP B
 HV-51-199B

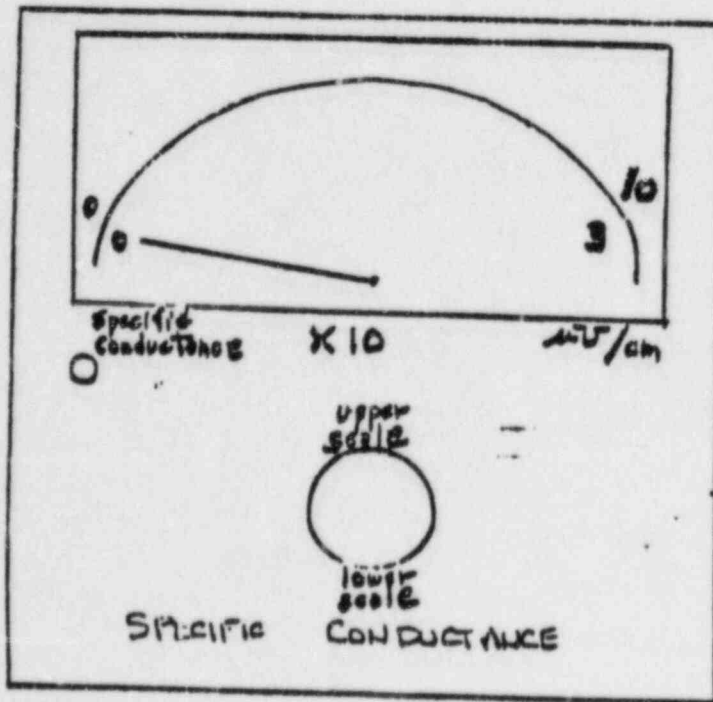
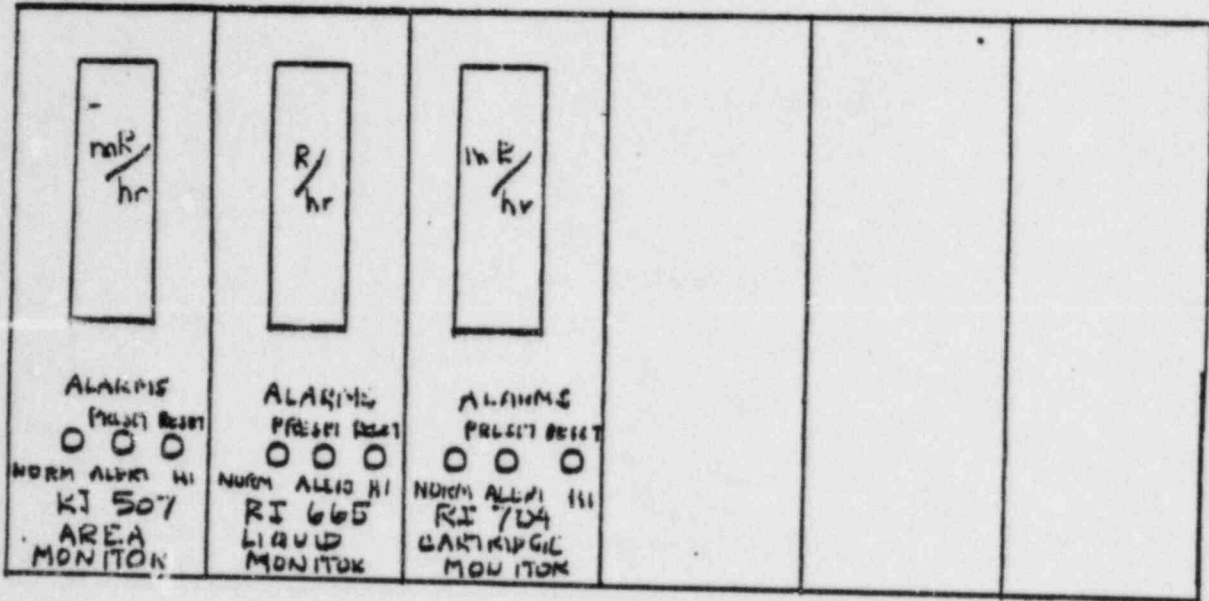
APPENDIX EP-231-9
 DIAGRAM OF CONTROL PANEL - RIGHT SIDE



APPENDIX EP-231-10
 CONTROL PANEL SWITCH LAYOUT

HC-715-1, SUMP DRAIN SYSTEM SWITCH

1. OFF
2. BLOW COLLECTOR
3. DRAIN COOLER TRAP
4. BLOW COLLECTOR
5. EVACUATE COLLECTOR
6. SUMP TO COLLECTOR
7. BLOW COLLECTOR
8. OFF

HC-600, POWER SELECTOR SWITCH

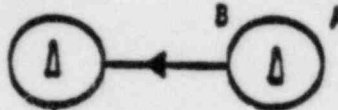

HC-626, LIQUID SAMPLE SOURCE SELECTOR SWITCH

1. JET PUMP LINE ON BYPASS
2. JET PUMP LINE
3. OFF
4. RPV OR SUPPRESSION POOL
5. RPV OR SUP'N POOL ON BYPASS

HC-700, LIQUID OR GAS SELECTOR SWITCH



HC-723, GAS SAMPLE SELECTOR SWITCH

1. DRYWELL ATMOSPHERE
2. SUP'N POOL ATMOSPHERE
3. SECONDARY CONT'MT ATM
4. SPARE

HC-616-1, SMALL VOL SAMPLE SW

1. TAKE SAMPLE
2. OFF
3. FLUSH LOOP

HC-705, 10 ML GAS SAMPLE SWITCH

1. OFF
2. CIRCULATE GAS
3. EVACUATE BOTTLE
4. TAKE SAMPLE
5. FLUSH SYSTEM

HC-601, DISSOLVED GAS AND LIQUID SAMPLE SWITCH

1. OFF
2. START P-701 AND FLOW
3. START P-601
4. CIRCULATE AND SEPARATE GAS
5. INJECT TRACER GAS
6. CIRCULATE TRACER GAS
7. COLLECT DISSOLVED GAS
8. CIRCULATE AGAIN
9. COLLECT DIS'LVD GAS AGAIN
10. TAKE GAS SAM AND/OR RELIEVE
11. TAKE LIQUID SAMPLE

HC-1720



HC-712, IODINE CARTRIDGE SAMPLE SWITCH

1. OFF
2. CIRCULATE GAS
3. GAS THRU CARTRIDGE
4. EVACUATE CARTRIDGE
5. FLUSH CARTRIDGE

HC-652 HC-529-1



HC-628-1, FLUSH SYSTEM SWITCH

1. OFF
2. START FLUSH
3. FLUSH V-610 LOOP
4. FLUSH P-601 LOOP
5. FLUSH CV-615
6. FLUSH PIPING STATION
7. FLUSH CV-622 LOOP
8. OFF

HC-704



(TIMED SAMPLE)

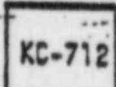

APPENDIX EP-231-11
SCHEMATIC OF POST ACCIDENT SAMPLE STATION

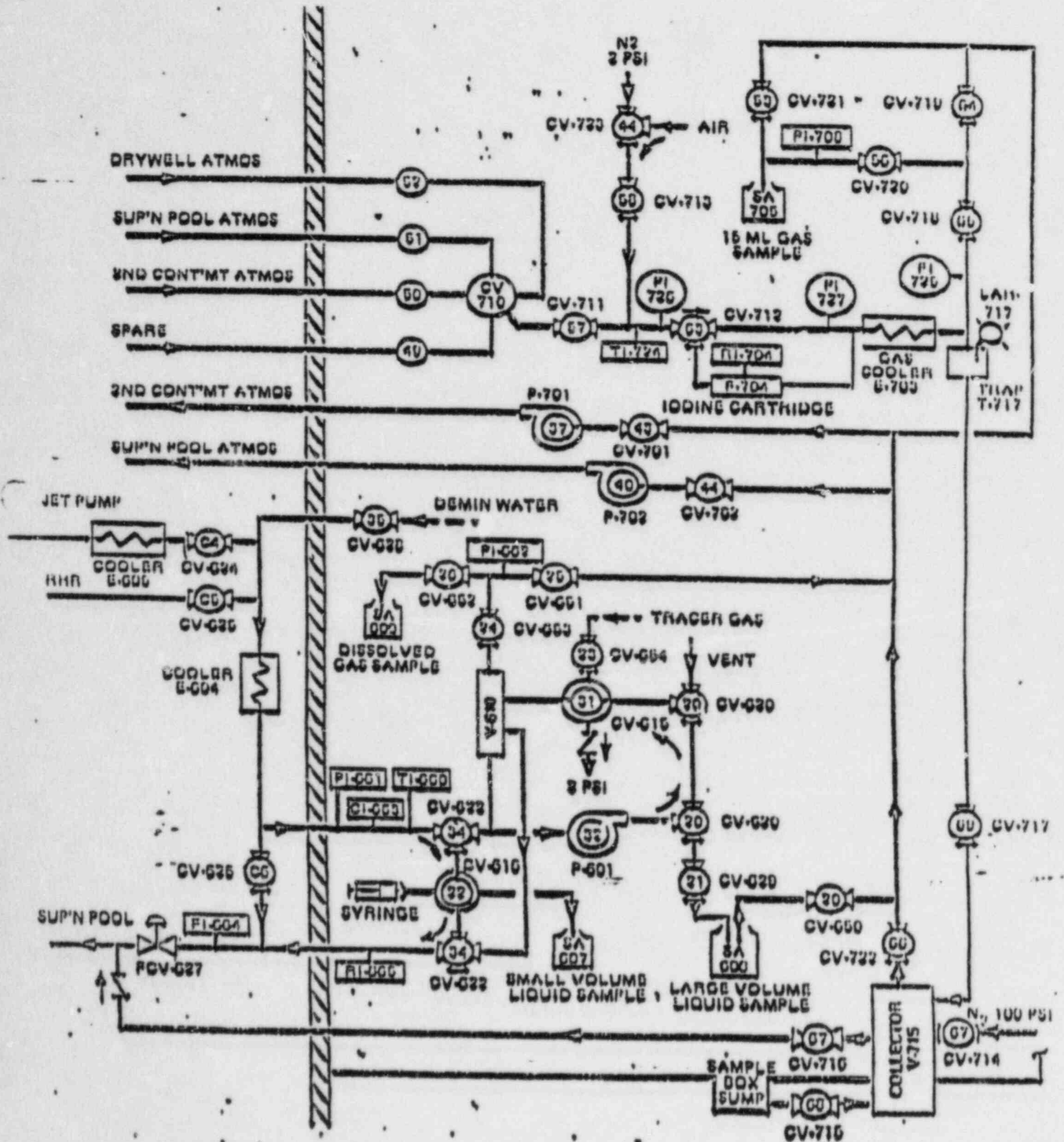

3842106680

EP-230 Rev. 3

Page 1 of 10

TJY/RGH/jmv

J. J. [Signature] 7/20/18

PHILADELPHIA ELECTRIC COMPANY
LIMERICK GENERATING STATION
EMERGENCY PLAN IMPLEMENTING PROCEDURE

EP-230 CHEMISTRY SAMPLING AND ANALYSIS TEAM ACTIVATION

1.0 PURPOSE

The purpose of this procedure is to provide guidelines for the actions required to activate the Chemistry Sampling and Analysis Team.

2.0 RESPONSIBILITIES

- 2.1 The (Interim) Emergency Director shall direct the Chemistry Sampling and Analysis Team Leader to activate a team, when required.
- 2.2 The Chemistry Sampling and Analysis Team Leader shall appoint a group leader to perform the steps necessary in this procedure.
- 2.3 The Chemistry Sampling and Analysis Group Leader shall direct the group members to perform the steps necessary in this procedure.

3.0 APPENDICES

- 3.1 EP-230-1 Emergency Exposure Guidelines
- 3.2 EP-230-2 Sample and Analysis Logsheet

4.0 PREREQUISITES

None

5.0 SPECIAL EQUIPMENT

None

CONTROLLED

VALID ONLY WHEN RED

6.0 SYMPTOMS

None

7.0 ACTION LEVEL

7.1 The Chemistry Sampling and Analysis Group will be activated at the discretion of the (Interim) Emergency Director.

8.0 PRECAUTIONS

- 8.1 Planned radiation exposures should be limited to the administrative guide levels in Appendix EP-230-1 Emergency Exposure Guidelines.
- 8.2 Continuous coverage by a Health Physics Technician may substitute for the Radiation Work Permit.
- 8.3 Every effort should be made to maintain the individual and man-rem exposures of the group to ALARA.

9.0 PROCEDURE

9.1 ACTIONS

- 9.1.1 The (Interim) Emergency Director shall:
- 9.1.1.1 Direct the (Interim) Chemistry Sampling and Analysis Team Leader to collect samples, as necessary, and analyze the samples or use offsite support groups for the analysis.
- 9.1.2 Senior Shift Chemistry technician shall:
- 9.1.2.1 Report to the Chemistry Field Office and verify habitability in accordance with EP-330, Emergency Response Facility Habitability. Report to the Chemistry Area on the 2nd floor of the Administration Building if the Chemistry Lab is not habitable. If the Chemistry Lab habitability is degraded, time spent in the lab analyzing samples should be minimized and protective measures shall be employed.

Consideration should be given to sending the samples offsite for analysis.

- 9.1.2.2 After discussing the situation with the Emergency Director to determine the priorities of group activation and immediate responses of the Chemistry Sampling and Analysis Team, assume the role of Interim Chemistry Sampling and Analysis Team Leader.

AT ANY POINT IN THIS PROCEDURE, THE CHEMISTRY SAMPLING AND ANALYSIS TEAM LEADER WILL REPORT TO THE TSC AND RELIEVE THE INTERIM TEAM LEADER ONCE FULLY COGNIZANT OF THE SITUATION.

- 9.1.2.3 Appoint Group Leaders from available personnel and/or assume the role of group leader and group member(s) (until relieved) and complete the appropriate steps in this procedure.
- 9.1.2.4 Assign sampling tasks to Group Leaders. Brief Group Leaders on plant status and potential or existing radiological conditions and/or hazards, as the information becomes available.
- 9.1.2.5 Request emergency exposure authorizations from the Emergency Director for the appropriate group members as required.
- 9.1.3 Chemistry Sampling and Analysis Group Leader shall:
 - 9.1.3.1 Assemble the Chemistry Sampling and Analysis Group Members at the Chemistry Field Office and perform accountability if required per EP-110 Personnel Assembly and Accountability.
 - 9.1.3.2 Obtain all PASS keys from the key cabinets located in the chemistry field office or chemistry administration office.
 - 9.1.3.3 Direct group member(s) to prepare sampling equipment using the appropriate procedures.
 - 9.1.3.4 Direct group member(s) to prepare sample preparation station, Counting Room and analysis instrumentation using the appropriate procedures.

- 9.1.3.5 Appoint group member(s) as necessary to assist in maintaining accountability logsheet, sampling and analysis logsheet, plant status record keeping and other appointed duties.
- 9.1.3.6 Evaluate sampling conditions and/or locations identified in steps 9.1.3.3 through 9.1.3.7 below and instruct group members to take the necessary samples using indicated procedures.
- 9.1.3.7 Refer to the following procedures to sample primary coolant and drywell atmosphere as necessary:
- EP-231 Operation of Post Accident Sampling System (PASS)
 - EP-233 Retrieving And Changing Sample Filters And Cartridges From The Containment Leak Detector During Emergencies
 - EP-234 Obtaining Containment Gas Samples From the Containment Leak Detector During Emergencies
 - EP-235 Obtaining Reactor Water Samples From Sample Sinks Following Accident Conditions
- 9.1.3.8 In the event of a unplanned radioactive liquid release, to the Schuylkill River, obtain samples of the blowdown line water in accordance with:
- EP-236 Obtaining Cooling Tower Blowdown Line Water Samples Following Radioactive Liquid Release After Accident Conditions

- 9.1.3.9 Use the following procedures to obtain samples, as necessary, from the various sample points.

North and South Stack

EP-237 Obtaining the Iodine/Particulate and/or gas samples from the North Vent Wide Range Gas Monitor (WRGM)

Liquid Radwaste

EP-238 Obtaining Liquid Radwaste Samples from Radwaste Sample Sink Following Accident Conditions

Off Gas

EP-240 Obtaining Off Gas Samples from the Air Ejector/Holdup pipe Discharge

Reactor Enclosure or Suppression Pool

EP-231 Operation of Post Accident Sampling Systems (PASS)

- 9.1.3.10 Use the following procedures for the preparation and handling of highly radioactive samples.

EP-241 Sample Preparation and Handling of Highly Radioactive Liquid Samples

EP-242 Sample Preparation and Handling of Highly Radioactive Particulate Filters and Iodine Cartridges

EP-243 Sample Preparation and Handling of Highly Radioactive Gas Samples

- 9.1.3.11 Periodically have group member exposures evaluated to ensure that group members do not exceed normal administrative exposure guidelines without prior approval of the (Interim) Emergency Director.

- 9.1.3.12 As required, request the Chemistry Sampling and Analysis Team Leader to obtain emergency exposure authorizations from the (Interim) Emergency Director for affected group members.

- 9.1.3.13 Assign a sample number to each sample to be analyzed and record on Appendix EP-230-2 Sample and Analysis Logsheet. Complete the appropriate line for each sample taken as the information becomes available.
- 9.1.3.14 Appropriately file the data sheets and analysis reports with Appendix EP-230-2 Sample and Analysis Logsheet for each sample analyzed.
- 9.1.4 Chemistry Sampling and Analysis Group Members shall:
 - 9.1.4.1 Assemble the necessary equipment needed to obtain and analyze samples. Label all sample containers before sampling.
 - 9.1.4.2 Collect and analyze samples as directed by the Group Leader.
 - 9.1.4.3 Give data sheets and analysis reports to the sampling and analysis Group Leader.

9.2 FOLLOW-UP

- 9.2.1 The (Interim) Chemistry Sampling and Analysis Team Leader shall:
 - 9.2.1.1 Report the results of these analyses to the (Interim) Emergency Director, Dose Assessment Team Leader and Health Physics and Chemistry Coordinator.
 - 9.2.1.2 Provide group leaders with periodic plant status changes including significant radiation exposure and radioactive contamination problems which may affect the functions of the team.
 - 9.2.1.3 If necessary, use the post accident sampling analysis off-site capabilities by referring to EP-244, Off-Site Analysis of High Activity Samples.
 - 9.2.1.4 Provide additional personnel support, if necessary, using EP-292 Chemistry Sampling and Analysis Team Phone List.

- 9.2.2 Chemistry Sampling and Analysis Group Leader shall:
 - 9.2.2.1 Report results of samples and analysis to the Chemistry Sampling and Analysis Team Leader.
 - 9.2.2.2 Provide Group Members with periodic plant status changes to include radiological condition which may affect the group.
 - 9.2.2.3 Request augmentative personnel from the Chemistry Sampling and Analysis Team Leader as required.

10.0 REFERENCES

- 10.1 Limerick Generating Station Emergency Plan
- 10.2 NUREG 0654, Rev. 2 - Preparation and Evaluation of Radiological Emergency Response Plans and Preparedness In Support of Nuclear Power Plants
- 10.3 EP-231 Operation of Post Accident Sampling System (PASS)
- 10.4 EP-233 Retrieving and Changing Sample Filters and Cartridges from the Containment Leak Detector during Emergencies
- 10.5 EP-234 Obtaining Containment Gas Samples from the Containment Leak Detector During Emergencies
- 10.6 EP-235 Obtaining Reactor Water Samples from Sample Sinks Following Accident Conditions
- 10.7 EP-236 Obtaining Cooling Tower Blowdown Line Samples Following Radioactive Liquid Releases After Accident Conditions
- 10.8 EP-237 Obtaining the Iodine/Particulate Samples and/or gas samples the North Vent Wide Range Gas Monitor (WRGM)
- 10.9 EP-238 Obtaining Liquid Radwaste Samples from the Radwaste Sample Sink Following Accident Conditions

- 10.10 EP-240 Off Gas Samples from the Air Ejector/Holdup Pipe Discharge
- 10.11 EP-241 Sample Preparation and Handling of Highly Radioactive Liquid Samples
- 10.12 EP-242 Sample Preparation and Handling of Highly Radioactive Particulate Filters and Iodine Cartridges
- 10.13 EP-243 Sample Preparation and Handling of Highly Radioactive Gas Samples
- 10.14 EP-292 Chemistry Sampling and Analysis Team Phone List
- 10.15 EP-110 Personnel Assembly and Accountability
- 10.16 EP-244 Off-Site Analysis of High Activity Samples

APPENDIX EP-230-1
Emergency Exposure Guidelines

<u>Function</u>	<u>Projected Whole Body Dose</u>	<u>Thyroid Dose</u>	<u>Authorized By</u>
1. Life Saving and Reduction of Injury	75 REM*	375 REM	(Interim) Emergency** Director
2. Operation of Equipment to Mitigate an Emergency	25 REM*	125 REM	(Interim) Emergency** Director
3. Protection of Health and Safety of the Public	5 REM	25 REM	(Interim) Emergency** Director
4. Other Emergency Activities	10 CFR 20 limits	10 CFR 20 limits	Emergency Director
5. Re-entry/Recovery Activities	Station Administrative Guidelines	Station Administrative Guidelines	N/A

* Reference: EPA-520/1-75-001 Table 2.1
 ** Such exposure shall be on a voluntary basis

APPENDIX EP-230-2
SAMPLING & ANALYSIS LOGSHEET

Date: _____

Sample #	Sample Source	Sample* Type	Time Sample Requested	Time Sample Received	Time Analysis Results Reported

* Sample Type: - Charcoal
 - Liquid
 - Gas

* - Smear
 - Other (describe)

JM Litch 7/20/84

PHILADELPHIA ELECTRIC COMPANY
LIMERICK GENERATING STATION
EMERGENCY PLAN IMPLEMENTING PROCEDURE

EP-233 RETRIEVING AND CHANGING SAMPLE FILTERS AND CARTRIDGES
FROM THE CONTAINMENT LEAK DETECTOR DURING EMERGENCIES

1.0 PURPOSE

This procedure provides guidelines for retrieving and changing particulate filters and charcoal cartridges (or silver zeolite cartridges) located at the Containment Leak Detector following accident conditions.

2.0 RESPONSIBILITIES

2.1 The Chemistry Sampling and Analysis Group Leader shall direct the group members to perform the steps necessary in this procedure.

3.0 APPENDICES

3.1 EP-233-1 - Data Sheet

4.0 PREREQUISITES

None

5.0 SPECIAL EQUIPMENT

- 5.1 Transport container (shielded)
- 5.2 Combined Filter/Cartridge holder assembly
- 5.3 2-Extra particulate filters
- 5.4 2-Extra iodine cartridges
- 5.5 Plastic bags

CONTROLLED

VALID ONLY WITH RED

6.0 SYMPTOMS

None

7.0 ACTION LEVEL

This procedure shall be implemented when a Containment Filter/Cartridge sample is to be taken from the Containment Leak Detector during an Emergency

8.0 PRECAUTIONS

- 8.1 Planned radiation exposures should be limited to the administrative guide levels in Appendix EP-230-1 Emergency Exposure Guidelines.
- 8.2 Do not use elevators.
- 8.3 Eye protection should be worn by all personnel when obtaining samples from the sample stations.
- 8.4 Continuous coverage by a Health Physics Technician may substitute for the Radiation Work Permit.

9.0 PROCEDURE

9.1 Actions

- 9.1.1 (Interim) Chemistry Sampling and Analysis Team Leader shall:
 - 9.1.1.1 After discussing the situation with the (Interim) Emergency Director determine if a filter/cartridge sample from the Containment Leak Detector is required.
 - 9.1.1.2 Check the Plant Radiation Level Status Board to forecast anticipated radiological conditions.
 - 9.1.1.3 Contact the Personnel Safety Team Leader and check on the latest developments related to radiological conditions and inform him what sample(s) are to be taken and that Health Physics' coverage is required.

- 9.1.1.4 Request input from the Control Room (via Emergency Director) to ascertain desired sample system availability.
- 9.1.1.5 Determine what analyses are required and inform the Chemistry Sampling and Analysis Group Leader what analyses are required. If an iodine particulate sample is required, recommend sampling time.
- 9.1.1.6 Request Emergency Exposure Authorizations from the Emergency Director for Group Members (as required) and inform the Personnel Safety Team Leader of this development.
- 9.1.1.7 Direct the Chemistry Sampling and Analysis Group Leader to collect and analyze the filter/cartridge sample.
- 9.1.2 Chemistry Sampling and Analysis Group Leader shall:
- 9.1.2.1 Assign the appropriate number of group members to obtain the necessary equipment to collect and transport the sample to the Chemistry Hot Lab.
- 9.1.2.2 Contact the Chemistry Sampling and Analysis Team Leader (TSC) for an estimated sampling time and record this time on Appendix EP-233-1.
- 9.1.2.3 Brief the Technician and Chemistry Sampling and Analysis Group members on the following:
- A. Communications equipment and channel
 - B. Type of sample(s) to be collected
 - C. Location of sample points
 - D. Suggested routes to be taken

- F. Review of the procedures to be followed for sample collection, handling, preparation and analysis
- G. Special tools and equipment required for sample handling and/or collection.
- H. Proper completion of Data Sheets.

9.1.2.4 Contact Shift operations in the Control Room to request system line up so that the selected sample can be taken from the desired Sample Station and sample point.

If the Containment Leak Detector is isolated, shift operations shall defeat the signal by placing jumpers across the following contacts:

DO NOT DEFEAT ISOLATION OF HIGH DRYWELL PRESSURE WHEN DRYWELL PRESSURE IS GREATER THAN 5 PSIG.

<u>Panel</u>	<u>Relay</u>	<u>Contacts</u>	<u>Isolation Signal</u>
10C609 (20C609)	B21H-K120C	T4-M4	High D/W Pressure or -38" Vessel Level
10C611 (20C611)	B21H-K120B	T4-M4	High D/W Pressure or -38" Vessel Level

9.1.2.5 Appoint Group member(s) to prepare the Hot Lab for receiving the sample.

USE THE FOLLOWING PROCEDURES AS GUIDELINES FOR PREPARATION OF THE HOT LAB.

EP-241 (LIQUID) Sample Preparation and Handling of Highly Radioactive Liquid Samples

EP-242 (IODINE) Sample Preparation and Handling of Highly Radioactive Particulate

Filters and Iodine
Cartridges

EP-243 (GAS) Sample Preparation and
Handling of Highly
Radioactive Gas Samples

- 9.1.2.6 Dispatch the Chemistry Sampling and Analysis Team Members to the OSC for Health Physics support if radiological conditions permit or other appointed location as determined by the Plant Survey Group Leader.

- 9.1.3 The Health Physics Technician shall:
 - 9.1.3.1 Determine which route should be used for collecting and transporting the sample.

 - 9.1.3.2 Take appropriate radiation survey equipment and ensure that equipment is functional and calibrated.

 - 9.1.3.3 Provide Group Members with the appropriate dosimetry, protective clothing and respiratory equipment.

 - 9.1.3.4 Perform a pre-job briefing with the Chemistry technicians assigned to obtain the sample to discuss the following:
 - A. RWP requirements
 - B. Routes to be used
 - C. Authorized doses
 - D. Radiological concerns and precautions
 - E. Review of procedure for obtaining and transporting sample to hot lab
 - F. Suggested methods to maintain exposures ALARA
 - G. Stay times and Abort Criteria

 - 9.1.3.5 Provide constant coverage while obtaining, transporting and analyzing the

sample filter and cartridges from the Containment Leak Detector.

- 9.1.3.6 Monitor dose rates enroute and at the sample location. Upon entering the power block, the surveyors shall note trends in general radiation levels enroute to the Containment Leak Detector. If general area dose rates (unanticipated) exceed 10 R/hr gamma or 10 rad/hr beta prior to arriving at the door leading to Rx.-283', exit immediately and report to Chemistry Sampling and Analysis Group Leader. If dose rates (unanticipated) exceed 5 R/hr at the door leading to Rx. 283', leave the area immediately and report to Chemistry Sampling and Analysis Group Leader.
- 9.1.3.7 Survey the sample area and sample cask.
- 9.1.3.8 Document the sample cask survey results and give them to the Chemistry Sampling and Analysis Group Leader (or other designated group member) when arriving at the hot lab.
- 9.1.3.9 Provide constant coverage during sample preparation and handling as specified in EP-242.
- 9.1.4 Chemistry Sampling and Analysis Group members shall:
 - 9.1.4.1 Assemble for a pre-job briefing at the chemistry lab.
 - 9.1.4.2 Inform the Group Leader if they are approaching the administrative exposure guidelines, or may not have sufficient exposure remaining to successfully complete the assigned task.
 - 9.1.4.3 Obtain the necessary equipment to collect the sample and ensure that the hot lab is ready to accept the sample.

PROPERLY LABEL ALL SAMPLE CONTAINERS

- 9.1.4.4 Once the group has been briefed and the appropriate equipment has been assembled,

proceed to the OSC or other designated location for HP coverage. Once briefed by Health Physics, retrieve and change the sample filters and cartridges as follows:

- A. The HP Technician shall survey the Containment Leak Detector concentrating especially on the particulate filter/iodine cartridge assembly and sample lines.
- B. Obtain the sample. The time required to obtain a sample is approximately 10 minutes.
- C. FILTER/CARTRIDGE HOLDER ASSEMBLY CHANGE METHOD
 1. Verify that HS-26-190-1 (Pump 1 switch) is in the ON position and that only pump 1 light is lit. Turn switch HS-26-190-2 to OFF (pump 2 switch).
 2. Verify Flow Indicator (FI-26-190) indicates flow.
 3. Put switch HSS-26-190 (OPERATE/PURGE) in PURGE position and verify that the purge light is lit.
 4. Allow to purge for one minute.
 5. Close valves V-2 and V-3.
 6. Remove holder assembly, bag and place aside.

THIS ASSEMBLY MAY BE USED LATER.
SEE STEP 13.
 7. Install a new filter/cartridge assembly back into the line.
 8. Open valves V-2 and V-3.
 9. Close valve V-8.

10. Put switch HSS-26-190 in OPERATE position and verify that the OPERATE light is lit. Record the time as TIME-1 and flow as FLOW from FI-26-190 in Appendix EP-233-1.
11. Allow to flow for the desired amount of sample collection time and then turn HSS-26-190 to PURGE and record time as TIME-2.
12. Allow to purge for one minute.
13. Close valves V-2 and V-3.
14. Remove holder assembly and immediately have the Health Physics Technician Survey the sample and record the Initial Contact Dose Rate on Appendix EP-233-1 and bag and place the sample in a shielded transport container.
15. Reinstall the holder assembly previously removed (Step 5) if appropriate, or install a new holder assembly.
16. Open valves V-2, V-3 and V-8.
17. Put switch HSS-26-190 in OPERATE position and verify that the OPERATE light is lit.
18. Turn HS-26-190-2 (pump 2 switch) to ON.
19. Return to the hot lab with the sample by retracing one of the previously suggested routes.

9.1.4.5 Upon introduction of the sample into the hot lab, the sample will be handled and stored in a manner that personnel exposures are kept ALARA.

9.1.4.6 Inform the Group Leader as soon as the sample reaches the hot lab and inform him that the sample collection has been completed and what the sample status is.

9.2 Follow-up

9.2.1 Chemistry Sampling and Analysis Group members shall:

9.2.1.1 Complete Appendix EP-233-1

9.2.1.2 Prepare, handle and analyze the sample using EP-242 Sample Preparation and Handling of Highly Radioactive Particulate and Iodine Cartridges.

9.2.1.3 Report the results to the Chemistry Sampling and Analysis Group Leader.

9.2.1.4 Properly file the data sheets and report back to the Group Leader for reassignment.

9.2.1.5 Return all sampling equipment to the CHEMISTRY EMERGENCY CABINET.

9.2.2 Chemistry Sampling and Analysis Group Leader shall:

9.2.2.1 Notify Shift Supervision that a sample has been taken and the aligned valves may be returned to the "NORMAL" position (i.e., Remove Jumpers).

9.2.2.2 Ensure Group member(s) dose is monitored to ensure that exposure limits have not been exceeded.

9.2.2.3 Inform the Chemistry Sampling and Analysis Team Leader that the required sample is in the hot lab.

9.2.2.4 Direct group members to refer to EP-242 Sample Preparation and Handling of Radioactive Particulate and iodine cartridges for guidance for sample preparation and handling.

9.2.2.5 Obtain and review ALL Data Sheets report the sample results to the Chemistry Sampling and Analysis Team Leader and

attach all Data Sheets to Appendix EP-230-2.

9.2.3 Chemistry Sampling and Analysis Team Leader shall:

9.2.3.1 Report the results to the Emergency Director and the Health Physics and Chemistry Coordinator (EOF).

10.0 REFERENCES

- 10.1 EP-230 - Chemistry Sampling and Analysis Team Activation
- 10.2 EP-242 - Sample Preparation and Handling of Highly Radioactive Particulate and Iodine Cartridges
- 10.3 M-102 - General Arrangement Plan at El. 217'-0"
- 10.4 M-104 - General Arrangement Plan at El. 269'-0" & 283'-0"
- 10.5 M-26 - Sh. 1, Rev. 8; Sh. 2, Rev. 9; Sh. 3, Proposed Rev. 3; Sh. 4, Proposed Rev. 3 - Plant Process Radiation Monitoring P&ID
- 10.6 E-519, Sh. 1 of 2; Proposed Rev. 3

APPENDIX EP-233-1

DATA SHEET

Containment Leak Detector
Particulate/Iodine Grab Sample

ESTIMATED SAMPLING TIME: _____

DATE: _____

TIME: _____

| TIME-1: _____ CFM

| FLOW: _____ CFM

| TIME-2: _____ CFM

INITIAL CONTACT DOSE RATE: _____

| ANALYSIS REQUIRED: _____

NAME: _____

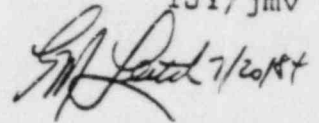
PHILADELPHIA ELECTRIC COMPANY
LIMERICK GENERATING STATION
EMERGENCY PLAN IMPLEMENTING PROCEDUREEP-234 OBTAINING CONTAINMENT GAS SAMPLES FROM THE CONTAINMENT
LEAK DETECTOR DURING EMERGENCIES1.0 PURPOSE

This procedure provides guidelines for obtaining gas samples from the Containment Leak Detector during emergencies.

2.0 RESPONSIBILITIES

2.1 The Chemistry Sampling and Analysis Group Leader shall direct the group members to perform the steps necessary in this procedure.

3.0 APPENDICES

- 3.1 EP-234-1 - Diagram of Gas Sampling Apparatus
- 3.2 EP-234-2 - Data Sheet

4.0 PREREQUISITES

None

5.0 SPECIAL EQUIPMENT

- 5.1 Transport container (shielded)
- 5.2 Gas Sampling Apparatus
- 5.3 3 off-gas vials with septums
- 5.4 Appropriate microsyringes
- 5.5 Plastic bags

CONTROLLED**VALID ONLY WHEN RED**

6.0 SYMPTOMS

None

7.0 ACTION LEVEL

This procedure shall be implemented when a gas sample shall be taken from the Containment Leak Detector during an Emergency.

8.0 PRECAUTIONS

- 8.1 Planned radiation exposures should be limited to the administrative guide levels in Appendix EP-230-1 Emergency Exposure Guidelines.
- 8.2 Do not use elevators.
- 8.3 Eye protection should be worn by all personnel when obtaining samples from the sample stations.
- 8.4 Continuous coverage by a Health Physics Technician may substitute for the Radiation Work Permit.

9.0 PROCEDURE

9.1 ACTIONS

- 9.1.1 (Interim) Chemistry Sampling and Analysis Team Leader shall:
 - 9.1.1.1 After discussing the situation with the (Interim) Emergency Director determine if a gas sample from the containment leak detector is required
 - 9.1.1.2 Check the Plant Radiation Level Status Board to forecast anticipated radiological conditions.
 - 9.1.1.3 Contact the Personnel Safety Team Leader and check on the latest developments related to radiological conditions and inform him what sample(s) are to be taken and that Health Physics' coverage is required.

- 9.1.1.4 Request input from the Control Room (via Emergency Director) to ascertain the desired sample system availability.
- 9.1.1.5 Determine what analyses are required and inform the Chemistry Sampling and Analysis Group Leader what analyses are required.
- 9.1.1.6 Request Emergency Exposure Authorizations from the Emergency Director for Group Members (as required) and inform the Personnel Safety Team Leader of this development.
- 9.1.1.7 Direct the Chemistry Sampling and Analysis Group Leader to collect and analyze the filter/cartridge sample.
- 9.1.2 Chemistry Sampling and Analysis Group Leader shall:
 - 9.1.2.1 Assign the appropriate number of group members to obtain the necessary equipment to collect and transport the sample to the Chemistry Hot Lab.
 - 9.1.2.2 Brief the Chemistry Sampling and Analysis Group members on the following:
 - A. Communications equipment and channel
 - B. Type of sample(s) to be collected
 - C. Location of sample points
 - D. Suggested routes to be taken
 - E. Sample transport technique
 - F. Projected amount of time required to collect and transport the sample
 - G. Review of the procedures to be followed for sample collection, handling, preparation and analysis
 - H. Special tools and equipment required for sample handling and/or collection.
 - I. Proper completion of Data Sheets

9.1.2.3 Contact Shift operations in the Control Room to request system line up so that the selected sample can be taken from the desired Sample Station and sample point.

If the Containment Leak Detector is isolated, shift operations shall defeat the signal by placing jumpers across the following contacts:

DO NOT DEFEAT ISOLATION OF HIGH DRYWELL PRESSURE WHEN DRYWELL PRESSURE IS GREATER THAN 5 PSIG.

<u>Panel</u>	<u>Relay</u>	<u>Contacts</u>	<u>Isolation Signal</u>
10C609 (20C609)	B21H-K120C	T4-M4	High D/W Pressure or -38" Vessel Level
10C611 (20C611)	B21H-K120B	T4-M4	High D/W Pressure or -38" Vessel Level

9.1.2.4 Appoint Group member(s) to prepare the Hot Lab for receiving the sample.

USE THE FOLLOWING PROCEDURES AS GUIDELINES FOR PREPARATION OF THE HOT LAB.

EP-241 (LIQUID) Sample Preparation and Handling of Highly Radioactive Liquid Samples

EP-242 (IODINE) Sample Preparation and Handling of Highly Radioactive Particulate Filters and Iodine Cartridges

EP-243 (GAS) Sample Preparation and Handling of Highly Radioactive Gas Samples

9.1.2.5 Dispatch the Chemistry Sampling and Analysis Group Members to the OSC for Health Physics Support if radiological conditions permit or other appointed location as determined by the Plant Survey Group Leader.

9.1.3 The Health Physics Technician shall:

9.1.3.1 Determine which route should be used for collecting and transporting the sample.

- 9.1.3.2 Take appropriate radiation survey equipment and ensure that equipment is functional and calibrated.
- 9.1.3.3 Provide Group Members with the appropriate dosimetry, protective clothing and respiratory equipment.
- 9.1.3.4 Perform a pre-job briefing with the Chemistry technicians assigned to obtain the sample to discuss the following:
 - A. RWP requirements
 - B. Routes to be used
 - C. Authorized doses
 - D. Radiological concerns and precautions
 - E. Review of procedure for obtaining and transporting sample to hot lab
 - F. Suggested methods to maintain exposures ALARA
 - G. Stay times and Abort Criteria
- 9.1.3.5 Provide constant coverage while obtaining, transporting and analyzing the sample from the Containment Leak Detector.
- 9.1.3.6 Monitor dose rates enroute and at the sample location. Upon entering the power block, the surveyors will note trends in general radiation levels enroute to the Containment Leak Detector. If general area dose rates (unanticipated) exceed 10 R/hr gamma or 10 rad/hr beta prior to arriving at the door leading to Rx.-283', exit immediately and report to Chemistry Sampling and Analysis Group Leader. If dose rates (unanticipated) exceed 5 R/hr at the door leading to Rx. 283', leave the area immediately and report to Chemistry Sampling and Analysis Group Leader.
- 9.1.3.7 Survey the sample area and sample cask.

- 9.1.3.8 Document the sample cask survey results and give them to the Chemistry Sampling and Analysis Group Leader (or other designated group member) when arriving at the hot lab.
- 9.1.3.9 Provide constant coverage during sample preparation and handling as specified in EP-243.
- 9.1.4 Chemistry Sampling and Analysis Group members shall:
 - 9.1.4.1 Assemble for a pre-job briefing at the chemistry lab.
 - 9.1.4.2 Inform the Group Leader if they are approaching the administrative exposure guidelines, or may not have sufficient exposure remaining to successfully complete the assigned task.
 - 9.1.4.3 Obtain the necessary equipment to collect the sample and ensure that the hot lab is ready to accept the sample.
 - 9.1.4.4 Prepare three off gas sample vials by withdrawing from the sample vial (with a syringe) the same volume that is to be injected as a sample.

PROPERLY LABEL ALL SAMPLE CONTAINERS
 - 9.1.4.5 Once the group has been briefed and the appropriate equipment has been assembled, proceed to the OSC or other designated location for Health Physics Coverage. Once briefed by Health Physics, proceed to the Containment Leak Detector area and collect a containment gas sample.
 - A. Proceed to the Containment Leak Detector.
 - B. Have the H.P. Technician survey the Containment Leak Detector.
 - C. Obtain the sample. The time required to obtain a sample is approximately 10 minutes.

D. SAMPLING METHOD

1. Verify that HS-26-190-1 (pump 1 switch) is in the ON position and that pump 1 light is lit. Turn switch HS-26-190-2 switch (pump 2 switch) to OFF.
2. Verify Flow Indicator (FI-26-190) indicates flow.
3. Put switch HSS-26-190 (OPERATE/PURGE) in PURGE position and verify that the PURGE light is lit.
4. Allow to purge for one minute.
5. Close valves V-2 and V-3.
6. Disconnect the filter holder assembly on the outlet side and install the gas sampling apparatus (similar to the one described in Appendix EP-234-1) making sure the sample valve and septum valve are closed.
7. Open valves V-2 and V-3.
8. Close valve V-8.
9. Put switch HSS-26-190 in OPERATE position and verify that the OPERATE light is lit.
10. Open the sample valve.
11. Open the septum valve.
12. Insert the 1.0 ml microsyringe through the septum valve and the sample valve into the sample tee.
13. Flush the microsyringe by taking a 1.0 ml sample and injecting it back into the sample tee two times.
14. Take a 1.0 ml sample and remove the microsyringe from the sample tee. Inject the sample into a 14.4 ml off gas vial. Place the microsyringe in a plastic bag and secure.

15. Have the HP Technician immediately survey the vial and record the Initial Contact Dose Rate in Appendix EP-234-2 and using remote handling tools, place the vial into an appropriate shielded transport container.
16. Complete Appendix EP-234-2.
17. Close the sample and septum valves.
18. Turn HS-26-190-2 switch (pump 2 switch) to ON.
19. Take the sample to the hot lab retracing one of the previously suggested routes.

9.1.4.7 Upon introduction of the sample into the hot lab, the sample will be handled and stored in a manner that personnel exposures are kept ALARA.

9.1.4.8 Inform the Group Leader as soon as the sample reaches the hot lab and inform him that the sample collection has been completed and what the sample status is.

9.2 FOLLOW-UP

9.2.1 Chemistry Sampling and Analysis Group Members shall:

9.2.1.1 Complete Appendix EP-234-2

9.2.1.2 Prepare, handle and analyze the sample using EP-243 Preparation and Handling of Highly Radioactive Gas Samples.

9.2.1.3 Report the results to the Chemistry Sampling and Analysis Group Leader.

9.2.1.4 Return all sampling equipment to the CHEMISTRY EMERGENCY CABINET.

9.2.2 Chemistry Sampling and Analysis Group Leader shall:

- 9.2.2.1 Notify Shift Supervision that a sample has been taken and the aligned valves may be returned to the "NORMAL" position (i.e., remove Jumpers).
- 9.2.2.2 Ensure Group Member(s) dose is monitored to ensure that exposure limits have not been exceeded.
- 9.2.2.3 Inform the Chemistry Sampling and Analysis Group Leader that the required sample is in the hot lab.
- 9.2.2.4 Direct Group Members to refer to EP-243 Sample Preparation and Handling of Radioactive Gas Samples for guidance for sample preparation and handling.
- 9.2.2.5 Obtain and review all Data Sheets and report the sample results to the Chemistry Sampling and Analysis Group Leader and attach all Data Sheets to Appendix EP-230-2.
- 9.2.3 Chemistry Sampling and Analysis Group Leader shall:
 - 9.2.3.1 Report the results to the Emergency Director and the Health Physics and Chemistry Coordinator (EOF).

10.0 REFERENCES

- 10.1 EP-230 - Chemistry Sampling and Analysis Group Activation
- 10.2 EP-243 - Preparation and Handling of Highly Radioactive Gas Samples
- 10.3 M-102 - General Arrangement Plan at El. 217'-0"
- 10.4 M-104 - General Arrangement Plan at El. 269'-0" & 283'-0"
- 10.5 M-26 P&ID, Sh. 1, Rev. 8; Sh. 2, Rev. 9; Sh. 3, Rev. 3; Sh. 4, Rev. 3 - Plant Process Radiation Monitoring
- 10.6 E-519, Sh. 1 of 2; Rev. 3

APPENDIX EP-234-1
DIAGRAM OF GAS SAMPLING APPARATUS

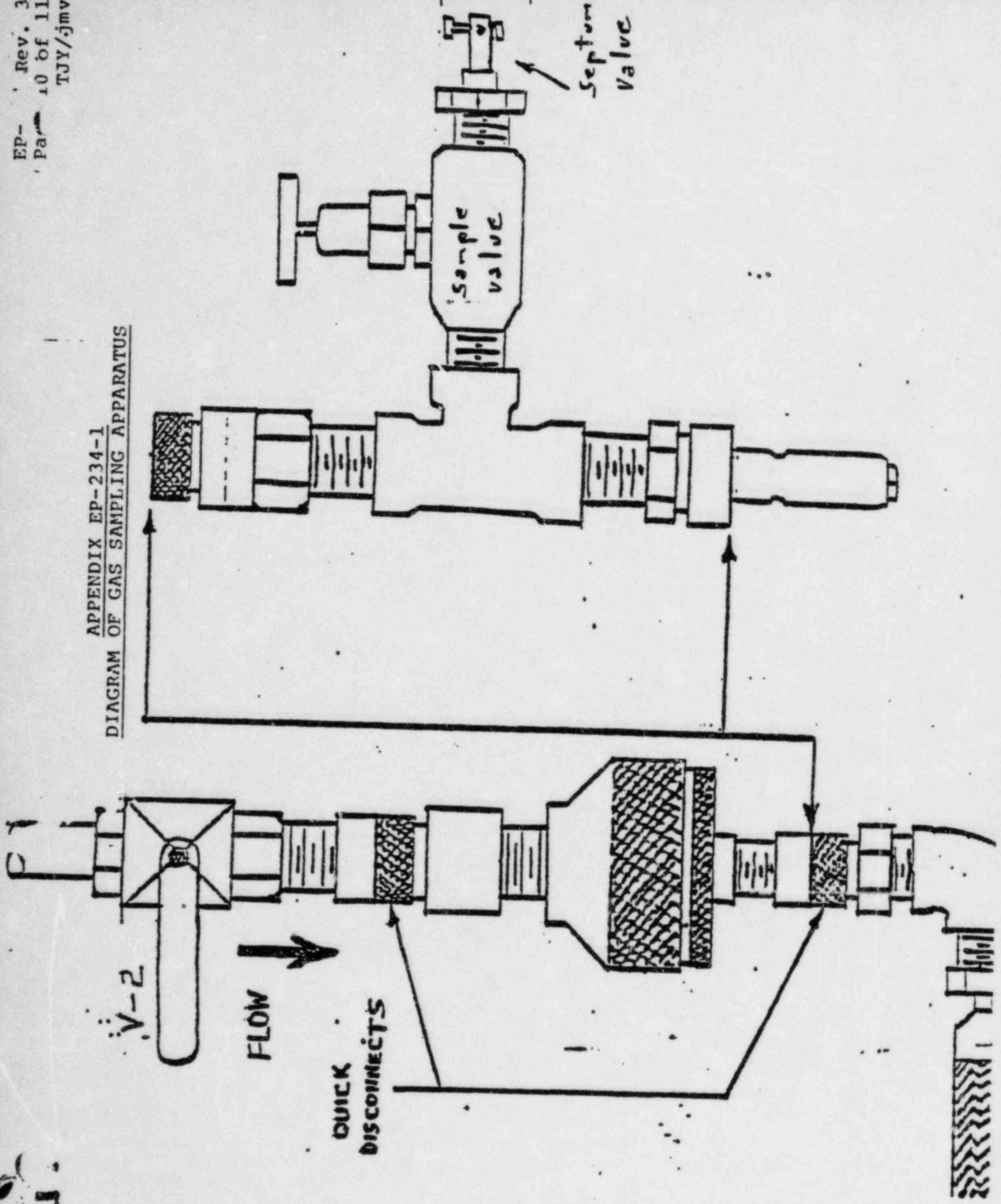

APPENDIX EP-234-2

DATA SHEET

Containment Leak Detector - Gas Grab Sample

DATE: _____

TIME: _____

VOLUME: 1.0 ml

INITIAL CONTACT DOSE RATE: _____

ANALYSIS REQUIRED: _____

NAME _____

J. J. Lett 7/20/87

PHILADELPHIA ELECTRIC COMPANY
LIMERICK GENERATING STATION
EMERGENCY PLAN IMPLEMENTING PROCEDURE

EP-235 OBTAINING REACTOR WATER SAMPLES FROM SAMPLE SINKS
FOLLOWING ACCIDENT CONDITIONS

1.0 PURPOSE

The purpose of this procedure is to provide guidelines for consideration prior to, during and after obtaining a reactor water sample following accident conditions with major fuel damage.

2.0 RESPONSIBILITIES

2.1 The Chemistry Sampling and Analysis Group Leader shall direct the group members in performing the steps necessary in this procedure.

3.0 APPENDICES

3.1 EP-235-1 Data Sheet

4.0 PREREQUISITES

None

5.0 SPECIAL EQUIPMENT

5.1 4 oz. sample bottle with lid

5.2 Tongs or remote tooling for holding the sample bottle during sampling

5.3 Eye Protection

5.4 Plastic bags

5.5 Sample station key

CONTROLLED

VALID ONLY WHEN RED

6.0 SYMPTOMS

None

7.0 ACTION LEVEL

7.1 This procedure shall be implemented when a Reactor water sample must be taken from the Reactor Enclosure sample stations during an emergency situation.

8.0 PRECAUTIONS

8.1 In all steps of this procedure, an ALARA concept is mandatory. Sampling and Analysis Group members' exposure should be limited to the administrative guide levels in EP-230, Chemistry Sampling and Analysis Team Activation, Appendix EP-230-1, Emergency Exposure Guidelines.

8.2 Do not use elevators.

8.3 Eye protection should be worn by all personnel obtaining the sample.

9.0 PROCEDURE

9.1 ACTIONS

9.1.1 (Interim) Chemistry Sampling and Analysis Team Leader shall:

9.1.1.1 After discussing the situation with the (Interim) Emergency Director, determine if a reactor water sample is required.

9.1.1.2 Determine preference of sampling points from below:

1. Reactor Water Clean up Filter
Demineralizer Inlet
2. Reactor Water Recirculation Inlet
3. Main Steam from Reactor

Inform the Chemistry Sampling and Analysis Group Leader of sampling point preference.

- 9.1.1.3 Check the Plant Radiation Level Status Board to forecast anticipated radiological conditions.
- 9.1.1.4 Contact the Personnel Safety Team Leader and check on the latest developments related to radiological conditions and inform him what sample(s) are to be taken and that Health Physics' coverage is required.
- 9.1.1.5 Request input from the Control Room (via Emergency Director) to ascertain desired sample system availability.
- 9.1.1.6 Determine what analyses are required and inform the Chemistry Sampling and Analysis Group Leader what analyses are required.
- 9.1.1.7 Request Emergency Exposure Authorizations from the Emergency Director for Group Members (as required) and inform the Personnel Safety Team Leader of this development.
- 9.1.1.8 Direct the Chemistry Sampling and Analysis Group Leader to collect and analyze the reactor water sample from the sample sink
- 9.1.2 Chemistry Sampling and Analysis Group Leader shall:
 - 9.1.2.1 Check with shift operations whether a sample can be taken from the desired sample station and sample point.
 - A. Three sample points are available:
 - 1. Reactor Clean up Filter demin. Inlet
 - 2. Reactor Water Recirculation Inlet
 - 3. Main Steam from Reactor

9.1.2.2 If the reactor water clean up filter demin inlet sample point is to be used, contact the control room to determine if a Group III isolation signal is present.

A. If the Group III isolation signal is present, request shift operations to defeat the signal by placing jumpers across the following contacts:

SHIFT APPROVAL IS REQUIRED FOR THIS STEP.

B.

<u>Panel</u>	<u>Relay</u>	<u>Contacts</u>	<u>Isolation Signal</u>
10C622 (20C622)	B21H-K40A	T1-M1	SLCS Initiation
10C623 (20C623)	B21H-K40B	T1-M1	SLCS Initiation
10C623 (20C623)	B21H-K42	T1-M1	Non-Regen HX Outlet High Temp
10C609 (20C609)	B21H-K3A	T2-M2	-38" Vessel Level
10C609 (20C609)	B21H-K3C	T2-M2	-38" Vessel Level

DO NOT DEFEAT THE ISOLATIONS OF HIGH RWCU DIFFERENTIAL FLOW, HIGH AREA TEMPERATURE OR HIGH DIFFERENTIAL TEMPERATURE ON ROOM VENTILATION AS THIS INDICATES A LEAK IN THE SYSTEM.

9.1.2.3 If the Reactor Water Recirculation Inlet sample line has been isolated, contact the Control Room and request shift operations to defeat the isolation signal by placing jumpers across the following contacts:

SHIFT APPROVAL IS REQUIRED FOR THIS STEP

A.

<u>Panel</u>	<u>Relay</u>	<u>Contacts</u>	<u>Isolation Signal</u>
10C609 (20C609)	C71A-K7E	T1-M1	Main Steam Line High Radiation
10C611 (20C611)	C71A-K7H	T1-M1	Main Steam Line High Radiation
10C609 (20C609)	B21H-K3A	T2-M2	-38" vessel level
10C611 (20C609)	B21H-K3C	T2-M2	-38" Vessel Level

9.1.2.4 If the Main Steam from Reactor sample point has been isolated, contact the Control Room and request Shift Operations to defeat the isolation signal by placing jumpers across the following contacts:

SHIFT APPROVAL IS REQUIRED FOR THIS STEP

<u>VALVE</u>	<u>PANEL</u>	<u>RELAY</u>	<u>CONTACTS</u>	<u>ISOLATION SIGNAL</u>
HV-41-1F084	10C622 (20C622)	B21H-K23A	T3-M3	-38" Vessel Level High Steam Line Radiation
HV-41-1F085	10C633 (20C633)	B21H-K23D	T3-M3	-38" Vessel Level High Steam Line Radiation

9.1.2.5 Assign the appropriate number of group members to obtain the necessary equipment to collect and transport the sample to the Chemistry Hot Lab.

9.1.2.6 Brief the Chemistry Sampling and Analysis Group Members on the following:

- A. Communications equipment and channel
- B. Type of sample(s) to be collected
- C. Location of sample points
- D. Suggested routes to be taken
- E. Sample transport technique
- F. Projected amount of time required to collect and transport the sample

G. Review of the procedures to be followed for sample collection, handling, preparation and analysis

H. Proper completion of Data Sheets

9.1.2.7 Appoint Group Member(s) to prepare the Hot Lab for receiving the sample.

USE THE FOLLOWING PROCEDURES AS GUIDELINES FOR PREPARATION OF THE HOT LAB.

EP-241 (LIQUID) Sample Preparation and Handling of Highly Radioactive Liquid Samples

EP-242 (IODINE) Sample Preparation and Handling of Highly Radioactive Particulate Filters and Iodine Cartridges

EP-243 (GAS) Sample Preparation and Handling of Highly Radioactive Gas Samples

9.1.2.8 Dispatch the chemistry sampling and analysis team members to the OSC for Health Physics Support if radiological conditions permit or other appointed location as determined by the Plant Survey Group Leader.

9.1.3 The Health Physics Technician shall:

9.1.3.1 Determine which route shall be used to collect and transport the sample.

9.1.3.2 Take appropriate radiation survey equipment and ensure that equipment is functional and calibrated.

9.1.3.3 Provide Group Members with the appropriate dosimetry, protective clothing and respiratory equipment.

- 9.1.3.4 Perform a pre-job briefing with the Chemistry technicians assigned to obtain the sample to discuss the following:
- A. RWP requirements
 - B. Routes to be used
 - C. Authorized doses
 - D. Radiological concerns and precautions
 - E. Review of procedure for obtaining and transporting sample to hot lab
 - F. Suggested methods to maintain exposures ALARA
 - G. Stay times and Abort Criteria
- 9.1.3.5 Provide constant coverage while obtaining, transporting and analyzing the reactor water sample.
- 9.1.3.6 Monitor dose rates enroute and at the sample location, if upon entering the Power Block, if general area dose rates (unanticipated) exceed 10 R/hr gamma or 10 rad/hr beta prior to arriving at the point specified below, exit immediately and report to Chemistry Sampling and Analysis Group Leader.
- If the general area dose rate (unanticipated) exceeds 5 R/hr at the door leading to Rx. 253, leave the area immediately and report to Chemistry Sampling and Analysis Group Leader with this information.
- 9.1.3.7 Survey the sample area and sample cask.
- 9.1.3.8 Document the sample cask survey results and give them to the Chemistry Sampling and Analysis Group Leader (or other designated group member) when arriving at the hot lab.
- 9.1.3.9 Provide constant coverage during sample preparation and handling as specified in EP-241.

- 9.1.4 Chemistry Sampling and Analysis Group Members shall:
- 9.1.4.1 Assemble for a pre-job briefing at the chemistry lab
- 9.1.4.2 Inform the Group Leader if they are approaching the Administrative Exposure Guidelines, or may not have sufficient exposure remaining to successfully complete the assigned task.
- 9.1.4.3 Obtain the necessary equipment to collect the sample and ensure that the hot lab is ready to accept the sample.

PROPERLY LABEL ALL SAMPLE CONTAINERS

- 9.1.4.4 Once the Group has been briefed and the appropriate equipment has been assembled, proceed to the OSC or other designated location for HP coverage. Once briefed by Health Physics, collect the reactor water sample as follows:
- A. Proceed to the RWCU Sample Station in the Reactor Building.
 - B. Request the Health Physics Technician to survey the area, concentrating on the sample sink.
 - C. Proceed to the predetermined grab sample point.
 - D. Ensure that a flow is present. If not, attempt to initiate flow by opening root valves. If flow is not established, exit and consult Chemistry Sampling and Analysis Group Leader
 - E. SAMPLING METHOD
Obtain a 2 oz. sample (or less if activity is extreme) in a 4 oz. bottle. Use tongs or other remote handling tools for sample collection if required. When required amount of sample is obtained remove bottle from hood, quickly place lid on bottle and transport with tongs, other remote tools, or lead shielded carrying container.

- F. Have the HP Technician survey the vial and record the Initial Contact Dose Rate in Appendix EP-235-1.
 - G. Complete the Data Sheet in Appendix EP-235-1.
 - H. Take the sample to the hot lab retracing one of the previously suggested routes.
- 9.1.4.5 Upon introduction of the sample into the hot lab, the sample will be handled and stored in a manner that personnel exposures are kept ALARA.
- 9.1.4.6 Contact the Group Leader as soon as the sample reaches the hot lab and inform him that the sample collection has been completed and what the sample status is.

9.2 FOLLOW-UP

- 9.2.1 Chemistry Sampling and Analysis Group Members shall:
- 9.2.1.1 Prepare, handle and analyze the sample using EP-241, Sample Preparation and Handling of Highly Radioactive Liquid Samples.
 - A. Properly in place and shielded, the sample will be processed remotely (where and when possible). Careful handling of the sample is mandatory in preparation for analysis to minimize radiological conditions.
 - 9.2.1.2 Report the results to the Chemistry Sampling and Analysis Group Leader.
 - 9.2.1.3 Properly file the data sheets and report back to the Group Leader for re-assignment.
 - 9.2.1.4 Return all sampling equipment to the CHEMISTRY EMERGENCY CABINET.
- 9.2.2 Chemistry Sampling and Analysis Group Leader shall:

- 9.2.2.1 Notify Shift Supervision that a sample has been taken and the aligned valves may be returned to the "NORMAL" position (i.e. Remove Jumpers).
- 9.2.2.2 Ensure Group Member(s) dose is monitored to ensure that exposure limits have not been exceeded.
- 9.2.2.3 Inform the Chemistry Sampling and Analysis Team Leader that the required sample is in the hot lab.
- 9.2.2.4 Direct Group Members to refer to EP-241, Sample Preparation and Handling of Highly Radioactive Liquid Samples for guidance for sample preparation and handling.
- 9.2.2.5 Obtain and review ALL Data Sheets and report the sample results to the Chemistry Sampling and Analysis Team Leader and attach all Data Sheets to Appendix EP-230-2.
- 9.2.2.6 Obtain sample station key from Group Member.
- 9.2.3 Chemistry Sampling and Analysis Team Leader shall:
 - 9.2.3.1 Report the results to the Emergency Director and the Health Physics and Chemistry Coordinator (EOF).

10.0 REFERENCES

- 10.1 EP-230 Chemistry Sampling and Analysis Team Activation
- 10.2 M-23 P&ID, Sh. 3, Rev. 12 Process Sampling
- 10.3 M-102 General Arrangement Plan at el. 217'-0"
- 10.4 M-103 General Arrangement Plan at el. 239'-0" & 253'-0"
- 10.5 EP-241 Sample Preparation and Handling of Highly Radioactive Liquids

APPENDIX EP-235-1

DATA SHEET

Reactor Water Grab Sample

DATE: _____

TIME: _____

SAMPLE LOCATION:

UNIT 1 _____

UNIT 2 _____

SAMPLE POINT:

1. REACTOR WATER CLEAN UP FILTER DEMIN INLET _____
2. REACTOR WATER RECIRCULATION INLET _____
3. MAIN STEAM FROM REACTOR _____

VOLUME: _____

INITIAL CONTACT DOSE RATE _____

ANALYZED FOR: _____

NAME: _____

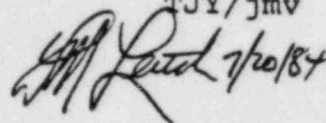
Handwritten signature and date: TJY/jmv 7/20/84

PHILADELPHIA ELECTRIC COMPANY
LIMERICK GENERATING STATION
EMERGENCY PLAN IMPLEMENTING PROCEDURE

EP-236 OBTAINING COOLING TOWER BLOWDOWN LINE WATER SAMPLES
FOLLOWING RADIOACTIVE LIQUID RELEASE AFTER ACCIDENT
CONDITIONS

1.0 PURPOSE

The purpose of this procedure is to provide guidelines to obtain Blowdown Line water samples following radioactive liquid releases after accident conditions.

2.0 RESPONSIBILITIES

2.1 The Chemistry Sampling and Analysis Group Leader shall direct the group members in performing the steps necessary in this procedure.

3.0 APPENDICES

3.1 EP-236-1 Data Sheet

4.0 PREREQUISITES

None

5.0 SPECIAL EQUIPMENT

- 5.1 1 liter sample bottles with lids
- 5.2 Plastic bags
- 5.3 Tape
- 5.4 Marker/Pen
- 5.5 Flash light

CONTROLLED

VALID ONLY WHEN RED

6.0 SYMPTOMS

None

7.0 ACTION LEVEL

7.1 This procedure shall be implemented when a Cooling Tower Blowdown Line water sample shall be taken during an emergency situation.

8.0 PRECAUTIONS

8.1 Planned radiation exposures should be limited to the administrative guide levels in Appendix EP-230-1 Emergency Exposure Guidelines.

8.2 If the Plant Survey Team Leader in conjunction with Chemistry Sampling and Analysis Team Leader determines that health physics coverage is not necessary, the steps performed by the health physics technician may be omitted.

9.0 PROCEDURE

9.1 Actions

9.1.1 (Interim) Chemistry Sampling and Analysis Team Leader shall:

9.1.1.1 After discussing the situation with the Emergency Director determine if a cooling tower blowdown line water sample is required.

9.1.1.2 Check the Plant Radiation Level Status Board to forecast anticipated radiological conditions.

9.1.1.3 Contact the Personnel Safety Team Leader and check on the latest developments related to radiological conditions and inform him what sample(s) are to be taken and that Health Physics' coverage may be required.

- 9.1.1.4 Request input from the Control Room (via Emergency Director) to ascertain desired sample system availability.
- 9.1.1.5 Determine what analyses are required and inform the Chemistry Sampling and Analysis Group Leader what analyses are required.
- 9.1.1.6 Request Emergency Exposure Authorizations from the Emergency Director for Group Members (as required) and inform the Personnel Safety Team Leader of this development.
- 9.1.1.7 Direct the Chemistry Sampling and Analysis Group Leader to collect and analyze the cooling tower blowdown line water sample.
- 9.1.2 Chemistry Sampling and Analysis Group Leader shall:
 - 9.1.2.1 Select the appropriate sample point. Four locations exist where the sample may be taken from.
 - A. Units 1 and 2 Cooling Tower Blowdown Line sample points (SX-09-104-(204)). Located in the pit between the Cooling Towers.
 - B. Effluent to river sample pump discharge grab sample (68-0061) and composite sample (68-0060) located behind Control Panel OBC580 in the Holding Pond Enclosure.
 - 9.1.2.2 Assign the appropriate number of group members to obtain the necessary equipment to collect and transport the sample to the Chemistry Hot Lab.
 - 9.1.2.3 Brief the Chemistry Sampling and Analysis Group members on the following:
 - A. Communications equipment and channel
 - B. Type of sample(s) to be collected
 - C. Location of sample points
 - D. Suggested routes to be taken

- E. Sample transport technique
- F. Projected amount of time required to collect and transport the sample
- G. Review the procedures to be followed for sample collection, handling, preparation and analysis
- H. Special tools and equipment required for sample handling and/or collection
- I. Proper completion of data sheets

9.1.2.4 Appoint one Group member to prepare the Hot Lab for receiving the sample.

USE THE FOLLOWING PROCEDURES AS GUIDELINES FOR PREPARATION OF THE HOT LAB.

EP-241 (LIQUID) Sample Preparation and Handling of Highly Radioactive Liquid Samples

EP-242 (IODINE) Sample Preparation and Handling of Highly Radioactive Particulate Filters and Iodine Cartridges

EP-243 (GAS) Sample Preparation and Handling of Highly Radioactive Gas Samples

9.1.2.5 Dispatch the Chemistry Sampling and Analysis Team Members to the OSC if necessary, or directly to the sample point of radiological conditions permit or other appointed location as determined by the Plant Survey Group Leader.

9.1.3 The Health Physics Technician if called upon shall:

9.1.3.1 Determine which route should be used for collecting and transporting the sample.

9.1.3.2 Take appropriate radiation survey equipment and ensure that equipment is functional and calibrated.

- 9.1.3.3 Provide Group Members with the appropriate dosimetry, protective clothing and respiratory equipment.
- 9.1.3.4 Perform a pre-job briefing with the Chemistry technicians assigned to obtain the sample to discuss the following:
 - A. RWP requirements
 - B. Routes to be used
 - C. Authorized doses
 - D. Radiological concerns and precautions
 - E. Review of procedure for obtaining and transporting sample to hot lab
 - F. Suggested methods to maintain exposures ALARA
 - G. Stay times and Abort Criteria
- 9.1.3.5 Provide constant coverage while obtaining, transporting and analyzing the sample, if required.
- 9.1.3.6 Document the sample survey results and give them to the Chemistry Sampling and Analysis Group Leader (or other designated group member) when arriving at the hot lab.
- 9.1.3.7 Provide constant coverage during sample preparation and handling as specified in EP 241, if required.
- 9.1.4 Chemistry Sampling and Analysis Group Members shall:
 - 9.1.4.1 Assemble for a pre-job briefing at the chemistry lab.
 - 9.1.4.2 Inform the Group Leader if they are approaching the Administrative exposure guidelines, or may not have sufficient exposure remaining to successfully complete the assigned task.
 - 9.1.4.3 Obtain the necessary equipment to collect the sample and ensure that the hot lab is ready to accept the sample.

PROPERLY LABEL ALL SAMPLE CONTAINERS

9.1.4.4 Once the Group has been briefed and the appropriate equipment has been assembled, proceed to the OSC or other designated location if necessary for HP coverage, or to appropriate sampling location and retrieve the water sample using the following.

A. COOLING TOWER BLOWDOWN LINE GRAB SAMPLE

- 1) Proceed to the desired sample point (SX-09-104, 204).
- 2) Position a one liter sample bottle under the sample point.
- 3) Open SX-09-104, -204 and fill sample bottle.
- 4) Close SX-09-104, -204.
- 5) Place lid on sample bottle and secure.
- 6) Place in a plastic bag and secure with tape.
- 7) Return switch opened in step No. 2 to the desired position.
- 8) Proceed to step 9.1.4.5.

B. EFFLUENT TO RIVER SAMPLE PUMP DISCHARGE LINE GRAB SAMPLE

- 1) Proceed to Control Panel OBC580.
- 2) Verify that switch HS68-003A (Effluent to River Sample Pump OAP900) or HS68-003B (Effluent to River Sample Pump OBP900) is on.
- 3) Open back panel and locate sample point. (Valve 68-0061).
- 4) Ensure that a flow is present. If not, attempt to initiate flow by opening root valves. If flow is not established, contact Chemistry Sampling and Analysis Group Leader for alternate sample points.
- 5) Obtain a one liter grab sample.

- 6) Place lid on sample bottle and secure.
- 7) Place in a plastic bag and secure with tape.
- 8) Return switch opened in step No. 2 to the desired position.
- 9) Have the HP Technician survey the sample and record the Initial Contact Dose Rate on Appendix EP-236-1.
- 10) Proceed to step 9.1.4.5.

C. EFFLUENT TO RIVER SAMPLE PUMP DISCHARGE LINE COMPOSITE SAMPLE

- 1) Proceed to Control Panel 0BC580.
- 2) Verify that switch HS68-003A (Effluent to River Sample Pump 0AP900) or HS68-003B (Effluent to River Sample Pump 0BP900) is on.
- 3) Open back panel and locate composite sampling container. (Valve 68-0061).
- 4) From the composite sampling bottle thoroughly mix the sample and transfer a 1 liter dip sample to an appropriate sample bottle.
- 5) Place lid on sample bottle and secure.
- 6) Place in a plastic bag and secure with tape.
- 7) Return switch opened in step No. 2 to the desired position.
- 8) Have the HP Technician survey the sample and record the Initial Contact Dose Rate on Appendix EP-236-1.

9.1.4.5 Complete the Data Sheet in Appendix EP-236-2.

- 9.1.4.6 Transport the sample to the Chemistry Hot Lab by retracing the route back from the sample point.
- 9.1.4.7 Upon introduction of the sample into the Hot Lab, the sample will be handled and stored in a manner that personnel exposures are kept ALARA.
- 9.1.4.8 Contact the Group Leader as soon as the sample reaches the Hot Lab and inform him that the sample collection has been completed and what the sample status is.

9.2 Follow-up

- 9.2.1 Chemistry Sampling and Analysis Team Leader shall:
 - 9.2.1.1 Report the results to the (Interim) Emergency Director Dose Assessment Team Leader and the Health Physics and Chemistry Coordinator (EOF).
- 9.2.2 Chemistry Sampling and Analysis Group Leader shall:
 - 9.2.2.1 Complete Appendix EP-236-1.
 - 9.2.2.2 Have the group member(s) dose monitored to ensure that exposure limits have not been exceeded.
 - 9.2.2.3 Inform the Chemistry Sampling and Analysis Team Leader that the required sample is in the Counting Room.
 - 9.2.2.4 Direct group member to refer to EP-241 Sampling Preparation and Handling of radioactive liquid samples for guidance for sample preparation and handling.
 - 9.2.2.5 Obtain and review all data sheets and report the sample results to the Chemistry Sampling and Analysis Team Leader and attach all data sheets to Appendix EP-230-2.
- 9.2.3 Chemistry Sampling and Analysis Group members shall:
 - 9.2.3.1 Prepare, handle and analyze the sample using EP-241, Sample Preparation and Handling of Radioactive Liquid Samples.

- 9.2.3.2 Report the results to the Chemistry Sampling and Analysis Group Leader.
- 9.2.3.3 Properly file the analysis report and report back to the Group Leader for reassignment.
- 9.2.3.4 Return all sampling equipment to the CHEMISTRY EMERGENCY CABINET.

10.0 REFERENCES

- 10.1 EP-230 Chemistry Sampling and Analysis Team Activation
- 10.2 M-09 P&ID, Sh. 1, Rev. 29, Circulating Water
- 10.3 M-68 P&ID, Rev. 4, Plant Waste Water Effluent
- 10.4 EP-241 - Sample Preparation and Handling of Radioactive Liquid Samples

APPENDIX EP-236-1

DATA SHEET

DATE: _____

TIME: _____

SAMPLE LOCATION: _____

TYPE OF SAMPLE: _____

VOLUME: _____

| ANALYSIS REQUIRED: _____
| _____
| _____

NAME: _____

JRR
7/20/84

PHILADELPHIA ELECTRIC COMPANY
LIMERICK GENERATING STATION
EMERGENCY PLAN IMPLEMENTING PROCEDURE

EP-237 OBTAINING THE IODINE/PARTICULATE AND/OR GAS SAMPLES FROM
THE NORTH VENT WIDE RANGE GAS MONITOR (WRGM)

1.0 PURPOSE

The purpose of this procedure is to provide guidelines for obtaining particulate/iodine and/or gas samples from the North Vent WRGM following accident conditions.

2.0 RESPONSIBILITIES

2.1 The Chemistry Sampling and Analysis Group Leader shall direct the group members to perform the steps necessary in this procedure.

3.0 APPENDICES

3.1 EP-237-1 Data Sheet

4.0 PREREQUISITES

Prior to entering the plant to obtain the sample, ensure that the iodine cartridges and particulate filter papers are adequate and properly installed by verifying that RT-5-026-620-0, routine changeout of iodine cartridges and particulate filters from the North Vent Wide Range Gas Monitor (WRGM) is properly completed.

5.0 SPECIAL EQUIPMENT

- 5.1 3-off gas vials with septums
- 5.2 Adjustable wrench
- 5.3 Channel lock pliers

CONTROLLED

VALID ONLY WHEN RED

- 5.4 Extremity dosimetry
- 5.5 Extra filter
- 5.6 Extra cartridge
- 5.7 Mininert-septum valve
- 5.8 Transport cask
- 5.9 Designated remote handling tools
- 5.10 Plastic bags
- 5.11 Screwdriver

6.0 SYMPTOMS

None

7.0 ACTION LEVEL

This procedure shall be implemented when a particulate, iodine or gas sample shall be taken from the North Vent WRGM during an emergency situation.

8.0 PRECAUTIONS

- 8.1 Planned radiation exposures should be limited to the administrative guide levels in Appendix EP-230-1 Emergency Exposure Guidelines.
- 8.2 Do not use elevators.
- 8.3 Eye protection should be worn when obtaining samples from the sample stations.
- 8.4 Continuous coverage by a Health Physics Technician may substitute for the Radiation Work Permit.

9.0 PROCEDURE

9.1 Actions

- 9.1.1 (Interim) Chemistry Sampling and Analysis Team Leader shall:
 - 9.1.1.1 After discussing the situation with the (Interim) Emergency Director, determine if a filter/cartridge or gas sample is required from the North Vent WRGM.
 - 9.1.1.2 Check the Plant Radiation Level Status Board to forecast anticipated radiological conditions.
 - 9.1.1.3 Contact the Personnel Safety Team Leader and check on the latest developments related to radiological conditions and inform him what sample(s) are to be taken and that Health Physics coverage is required.
 - 9.1.1.4 Request input from the Control Room (via Emergency Director) to ascertain desired sample system availability.
 - 9.1.1.5 Determine what analyses are required and inform the Chemistry Sampling and Analysis Group Leader what analyses are required. If an Iodine/Particulate sample is to be taken, recommend sampling time.
 - 9.1.1.6 Request Emergency Exposure Authorizations from the Emergency Director for Group Members (as required) and inform the Personnel Safety Team Leader of this development.
 - 9.1.1.7 Direct the Chemistry Sampling and Analysis Group Leader to collect and analyze the appropriate samples.
- 9.1.2 Chemistry Sampling and Analysis Group Leader shall:
 - 9.1.2.1 Assign the appropriate number of group members to obtain the necessary equipment to collect and transport the sample to the Chemistry Hot Lab.

9.1.2.2 Determine what type(s) of sample(s) are to be taken:

- A. Local Particulate/Iodine Sample
- B. Remote Particulate/Iodine Sample
- C. Gas Grab Sample

9.1.2.3 Brief the Chemistry Sampling and Analysis Group members on the following:

- A. Communications equipment and channel
- B. Type and sampling time of sample(s) to be collected
- C. Location of sample point
- D. Suggested routes to be taken
- E. Sample transport technique
- F. Projected amount of time required to collect and transport the sample
- G. Review of the procedures to be followed for sample collection, handling, preparation and analysis
- H. Special tools and equipment required for sample handling and/or collection
- I. Proper completion of Data Sheets.

9.1.2.4 Appoint Group member(s) to prepare the Hot Lab for receiving the sample.

USE THE FOLLOWING PROCEDURES AS GUIDELINES FOR PREPARATION OF THE HOT LAB.

EP-241 (LIQUID) Sample Preparation and Handling of Highly Radioactive Liquid Samples.

EP-242 (IODINE) Sample Preparation and Handling of Highly Radioactive Particulate Filters and Iodine Cartridges.

EP-243 (GAS)

Sample Preparation and
Handling of Highly
Radioactive Gas Samples.

- 9.1.2.5 Dispatch the Chemistry Sampling and Analysis Team members to the OSC for Health Physics Support if radiological conditions permit or other appointed location as determined by the Plant Survey Group Leader.
- 9.1.3 The Health Physics Technician shall:
- 9.1.3.1 Determine which route should be used to collect and transport the sample.
- 9.1.3.2 Take appropriate radiation survey equipment and ensure that equipment is functional and calibrated.
- 9.1.3.3 Provide Group Members with the appropriate Dosimetry, Protective Clothing and Respiratory Equipment.
- 9.1.3.4 Perform a pre-job briefing with the Chemistry technicians assigned to obtain the sample, to discuss the following:
- A. RWP requirements
 - B. Routes to be used
 - C. Authorized doses
 - D. Radiological concerns and precautions
 - E. Review of procedure for obtaining and transporting sample to hot lab
 - F. Suggested methods to maintain exposures ALARA
 - G. Stay times and Abort Criteria
- 9.1.3.5 Provide constant coverage while obtaining, transporting and analyzing the sample filter/cartridge and/or gas sample from the WRGM.
- 9.1.3.6 Monitor dose rates enroute to and at the sample location.

- A. Upon entering the power block, the surveyor shall note trends in general radiation levels enroute to the sample point. If general area dose rates (unanticipated) exceed 10 R/hr gamma or 10 Rad/hr beta, prior to arriving at the point specified below, immediately report to Chemistry Sampling and Analysis Group Leader. The following dose rates shall be determined prior to entry:
 - B. If the dose rate (unanticipated) exceeds 5 R/hr at the door leading to 217', 332', 352', or 411' E1. exit the area immediately and report to Chemistry Sampling and Analysis Group Leader with this information. With dose rates less than 5 R/hr., enter the desired elevation through that door. Take careful note of the dose rates.
 - C. If using the route suggested in procedure step 9.1.2.3, remember the stairs are next to the North Vent. If general area dose rate (unanticipated) exceeds 10 R/hr. gamma or 10 Rad/hr beta, exit the area immediately and report to Chemistry Sampling and Analysis Group Leader.
- 9.1.3.7 Survey the sample area and sample cask.
- 9.1.3.8 Document the sample cask survey results and give them to the Chemistry Sampling and Analysis Group Leader (or other designated group member) when arriving at the hot lab.
- 9.1.3.9 Provide constant coverage during sample preparation and handling as specified in EP-242 or 243.
- 9.1.4 Chemistry Sampling and Analysis Group members shall:
- 9.1.4.1 Assemble for a pre-job briefing at the chemistry lab.
 - 9.1.4.2 Inform the Group Leader if they are approaching the administrative exposure guidelines or do not have sufficient

exposure remaining to successfully complete the assigned task.

- 9.1.4.3 Obtain the necessary equipment to collect the sample and ensure that the hot lab is ready to accept the sample:
- A. Properly label all sample containers.
 - B. If a gas sample is to be taken, prepare three evacuated gas sampling vials by withdrawing from the sample vial (with a syringe) the same volume that is to be injected as a sample.
- 9.1.4.4 Once the group has been briefed and the appropriate equipment has been assembled, proceed to the OSC or other designated location for Health Physics coverage. Once briefed by Health Physics perform the appropriate section for the desired sample:
- A. For obtaining Local Particulate/Iodine Sample
 - B. For obtaining Remote Particulate/Iodine Sample
 - C. For obtaining a Gas Grab Sample
 - A. FOR OBTAINING LOCAL PARTICULATE/IODINE SAMPLE
 - 1. Proceed to the Control Room.
 - 2. Locate Control Room Panel
Timer/Control Assembly (RIX-26-076,
KIC-26-076-1, KIC-26-076-2).
 - 3. Verify POWER switch is ON.
 - 4. Verify the green LED's on RIX-26-076
(NORTH STACK W.R. ACCIDENT) are lit.
 - 5. Press CLEAR.

6. Press MON, 1, 3, 6, ITEM and the channel number will be displayed. Record channel number.

<u>CHANNEL NUMBER</u>	<u>RANGE BUTTON</u>
1	LOW RANGE
2	MID RANGE
3	HIGH RANGE

7. Push appropriate channel (RANGE) button. Record concentration.
8. Inform the Team Leader of the Range and Concentration and have him verify that the Estimated Sampling Time and Range Selection are feasible. Record the Range Selection and Sampling Time.
9. Proceed to the appropriate Section for the desired sample:

SECTION

A-1 LOW RANGE
A-2 MID/HIGH RANGE

A-1 LOW RANGE

10. Proceed to the North Vent WRGM.
11. Verify that the isolation valves (26-0026, 26-0027, 26-0028, 26-0029) on either side of the quick-disconnects for GRAB SAMPLE 1 are OPEN.
12. Locate Sample Conditioning Skid Control Station Electrical Enclosure. Open lid and set HSS-26-076-2, SKID CONTROL switch to LOCAL.
13. Verify the green REMOTE CONTROL DISABLE lamp is lit.
14. Verify that the POWER DISCONNECT SWITCH is ON.

15. On the Sample Detection Skid, ensure that the PUMP ON LOW green light is lit. If not, place the following switches in the appropriate position:

<u>RANGE</u>	<u>SWITCH NO.</u>	<u>NAME</u>	<u>POSITION</u>
LOW	HSS-26-076-8	Low Pump	ON
	HS-26-076-10	Flow Control (Low)	HAND
	HSS-26-076-6	Flow Control (Low)	OPEN

16. Ensure that the PUMP ON LOW green light is lit. If not, exit the area.
17. Record position (A or B) of HSS-26-076-4, FILTER SELECTOR LOW RANGE switch.
18. Turn HSS-26-076-4 to GRAB 1 position and immediately record the time as TIME-1 and record the flow from FI-26-076-2.
19. After the desired time has expired, turn HSS-26-076-4 to position A or B and immediately record the time as TIME-2 and record the position.
20. Close the isolation valves (26-0026, 26-0027, 26-0-28, 26-0029).
21. Release the band on the holder assembly and immediately have the HP Technician survey the sample and record the Initial Contact Dose Rate.
22. Remove the cartridge and filter paper and place into an appropriate transport cask.
23. Install a new cartridge and filter paper into the assembly.
24. Reclip the band on the holder assembly.

25. Open the isolation valves (26-0026, 26-0027, 26-0028, 26-0029).
26. Place the following switches in the appropriate position:

<u>RANGE</u>	<u>SWITCH NO.</u>	<u>NAME</u>	<u>POSITION</u>
LOW	HSS-26-076-8	Low Pump	AUTO
	HS-26-076-10	Flow Control (Low)	AUTO
	HSS-26-076-6	Flow Control (Low)	OPEN

27. Set HSS-26-076-2, SKID CONTROL switch to REMOTE.
28. Close Sample Conditioning Skid Control Station Electrical Enclosure lid and secure.
29. Transport the sample to the Chemistry Hot Lab.

A-2 MID/HIGH RANGE

10. Proceed to the North Vent WRGM.
11. Verify that the isolation valves (26-0021, 26-0022, 26-0023, 26-0024) on either side of the quick-disconnects for GRAB SAMPLE 2 are OPEN.
12. Locate Sample Conditioning Skid Control Station Electrical Enclosure. Open lid and set HSS-26-076-2, SKID CONTROL switch to LOCAL.
13. Verify the green REMOTE CONTROL DISABLE lamp is lit.
14. Verify that the POWER DISCONNECT SWITCH is ON.

15. On the Sample Detection Skid, ensure that the PUMP ON MID/HIGH green light is lit. If not, place the following switches in the appropriate position:

<u>RANGE</u>	<u>SWITCH NO.</u>	<u>NAME</u>	<u>POSITION</u>
MID/ HIGH	HSS-26-076-7	Mid/High Pump	ON
	HS-26-076-9	Flow Control (Mid/High)	HAND
	HSS-26-076-5	Flow Control (Mid/High)	OPEN

16. Ensure that the PUMP ON MID/HIGH green light is lit. If not, exit the area.
17. Record position (C or D) of HSS-26-076-3, FILTER SELECTOR HIGH RANGE switch.
18. Turn HSS-26-076-3 to GRAB 2 position and immediately record the time as TIME-1 and record the flow from FI-26-076-1.
19. After the desired time has expired, turn HSS-26-076-3 to position C or D and immediately record the time as TIME-2 and record the position.
20. Close the isolation valves (26-0021, 26-0022, 26-0023, 26-0024).
21. Open the door to the holder assembly and immediately have the HP Technician survey the holder assembly and record the Initial Contact Dose Rate.
22. Release the quick-disconnects on either side of the holder assembly and place the holder assembly into an appropriate transport cask or unlatch the holder assembly and place the cartridge and filter paper into an appropriate transport cask.
23. Install a new holder assembly complete with cartridge and filter

paper or install only a new cartridge and filter paper as applicable.

24. Close the door to the holder assembly.
25. Open the isolation valves (26-0021, 26-0022, 26-0023, 26-0024).
26. Place the following switches in the appropriate position:

<u>RANGE</u>	<u>SWITCH NO.</u>	<u>NAME</u>	<u>POSITION</u>
MID/ HIGH	HSS-26-076-7	Mid/High Pump	AUTO
	HS-26-076-9	Flow Control (Mid/High)	AUTO
	HSS-26-076-5	Flow Control (Mid/High)	OPEN

27. Set HSS-26-076-2, SKID CONTROL switch to REMOTE.
28. Close Sample Conditioning Skid Control Station Electrical Enclosure lid and secure.
29. Transport the sample to the Chemistry Hot Lab.

B. FOR OBTAINING REMOTE PARTICULATE/IODINE SAMPLE

1. Proceed to the Control Room.
2. Locate Control Room Panel Timer/Control Assembly (RIX-26-076, KIC-26-076-1, KIC-26-076-2).
3. Verify POWER switch is ON.
4. Verify SKID CONT-REMOTE light is lit.

IF SKID CONT-REMOTE LIGHT IS NOT LIT
AND SKID CONT-LOCAL LIGHT IS LIT,
THEN THE SAMPLE CONDITION SKID
CONTROL STATION ELECTRICAL ENCLOSURE
LID IS OPEN AND/OR THE SKID CONTROL

SWITCH (HSS-076-2) IS IN THE LOCAL POSITION.

Tell group leader remote sample is impossible and ask for further instructions.

5. Verify the green LED's on RIX-26-076 (NORTH STACK W.R. ACCIDENT).
6. Press CLEAR.
7. Press MON, 1, 3, 6, ITEM and the channel number will be displayed. Record channel number.

<u>CHANNEL NUMBER</u>	<u>RANGE BUTTON</u>
1	LOW RANGE
2	MID RANGE
3	HIGH RANGE

8. Push appropriate channel (Range) button. Record concentration.
9. Inform the Team Leader of the Range and Concentration and have him verify that the Estimated Sampling time and Range Selection is feasible. Record range selection and sampling time.
10. Proceed to the following section for the appropriate Range:

SECTION

B-1 LOW RANGE
B-2 MID/HIGH RANGE

B-1 LOW RANGE

11. Record letter (A or B) of prefilter in service (HSS-26-076-10).
12. Set KIC-26-076-2, LOW RANGE GRAB SAMPLE TIMER, to the desired sample time by use of the screwdriver adjustment and record the SAMPLING TIME.

13. Press START TIMER pushbutton (HS-26-076-2) and verify the timer display is counting. Record the time as TIME-1.
14. Press MON, 0, 2, 8, ITEM and the flow will be displayed. Record the flow.
15. When the timer stops counting, grab sample has been taken. Record time as TIME-2.
16. Press CLEAR.
17. Turn HSS-26-076-10 to the desired prefilter and record the letter (A or B) of prefilter in service.
18. Proceed to the North Vent WRGM.

GROUP MEMBERS AT THE WRGM PERFORM:

19. Close the isolation valves (26-0026, 26-0027, 26-0028, 26-0029) on each side of the quick-disconnects on GRAB SAMPLE 1.
20. Release the band on the holder assembly and immediately have the HP Technician survey the sample and record the Initial Contact Dose Rate. Remove the cartridge and filter paper and place into an appropriate transport cask.
21. Install a new cartridge and filter paper into the assembly and reclip the band.
22. Open the isolation valves (26-0026, 26-0027, 26-0028, 26-0029).
23. Transport the sample to the Chemistry Hot Lab.

B-2 MID/HIGH RANGE

11. Record letter (C or D) of prefilter in service (HSS-26-076-9).

12. Set KIC-26-076-1, MID HIGH RANGE GRAB SAMPLE TIMER, to the desired sample time by use of the screwdriver adjustment and record the SAMPLING TIME.
13. Press START TIMER pushbutton (HS-26-076-1) and verify the timer display is counting. Record the time as TIME-1.
14. Press MON, 0, 7, 2, ITEM and the flow will be displayed. Record the flow.
15. When the timer stops counting, grab sample has been taken. Record time as TIME-2.
16. Press CLEAR.
17. Turn HSS-26-076-9 to the desired prefilter and record the letter (C or D) or prefilter in service.
18. Proceed to the North Vent WRGM.
GROUP MEMBERS AT THE WRGM PERFORM:
19. Close the isolation valves (26-0021, 26-0022, 26-0023, 26-0024) on each side of the quick-disconnects on GRAB SAMPLE 2.
20. Open the door to the holder assembly and immediately have the HP Technician survey the holder assembly and record the Initial Contact Dose Rate.
21. Release the quick-disconnects on either side of the holder assembly and place the holder assembly into an appropriate transport cask.
22. Install a new holder assembly.
23. Open the isolation valves (26-0021, 26-0022, 26-0023, 26-0024).
24. Transport the sample to the Chemistry Hot Lab.

C. FOR OBTAINING A GAS GRAB SAMPLE

1. Proceed to the North Vent WRGM.
2. Verify that the green OPERATE light on the RM80/J BOX assembly is on.
3. Verify that Power Disconnect Switch on Sample Detection Skid assembly is on.
4. Verify that either PUMP ON LOW or PUMP ON MID/HIGH or both green lights are lit.
5. Verify that either MID/HIGH FLOW or LOW RANGE FLOW switches or both visual flow meters on sample detection skid are indicating flow.
6. Locate sample tap valve and verify that it is closed.
7. Remove plug and install septum valve and verify valve is closed.
7. Open sample tap valve.
9. Open septum valve.
10. Insert the 1.0 ml microsyringe through the septum valve and the septum valve into the tee connection.
11. Flush the microsyringe by taking a 1.0 ml sample and injecting it back into the sample tee two times.
12. Take a 1.0 ml sample and remove the microsyringe from the sample tee. Inject the sample into an evacuated 14.4 ml off gas vial.
13. Place the vial into an appropriate container for transportation to the Hot Lab.
14. Close the septum valve.
15. Close the sample tap valve.

16. Record the sample volume and activity in Appendix EP-237-3.

17. Have the HP Technician check the sample vial and record the In-Container Dose Rate.

18. Transport the sample to the hot lab by retracing the route back to the sample station.

9.1.4.5 Upon introduction of the sample into the hot lab, the sample will be handled and stored in a manner that personnel exposures are kept ALARA.

9.1.4.6 Contact the Group Leader as soon as the sample reaches the hot lab and inform him that the sample collection has been completed and what the sample status is.

9.2 Follow-up

9.2.1 Chemistry Sampling and Analysis Group members shall:

9.2.1.1 Complete Appendix EP-237-1.

9.2.1.2 Prepare, handle and analyze the sample using EP-242 or EP-243.

9.2.1.3 Report the results to the Chemistry Sampling and Analysis Group Leader.

9.2.1.4 Properly file the Data Sheets and report back to the Group Leader for reassignment.

9.2.1.5 Return all sampling equipment to the CHEMISTRY EMERGENCY CABINET.

9.2.2 Chemistry Sampling and Analysis Group Leader shall:

9.2.2.1 Ensure Group member(s) dose is monitored to ensure that exposure limits have not been exceeded.

9.2.2.2 Inform the Chemistry Sampling and Analysis Team Leader that the required sample is in the hot lab.

- 9.2.2.3 Direct group members to refer to EP-242 Sample Preparation and Handling of Radioactive Particulate and Iodine Cartridges or EP-243 Sample Preparation & Handling of Highly Radioactive Gas Samples, for guidance for sample preparation and handling.
- 9.2.2.4 Obtain and review ALL Data Sheets and report the sample results to the Chemistry Sampling and Analysis Team Leader and attach all Data Sheets to Appendix EP-230-2.
- 9.2.3 Chemistry Sampling and Analysis Team Leader shall:
 - 9.2.3.1 Report the results to the Emergency Director and the Health Physics and Chemistry Coordinator (EOF).

10.0 REFERENCES

- 10.1 EP-230 - Chemistry Sampling And Analysis Team Activation
- 10.2 M-102 - General Arrangement Plan At El. 217'-0"
- 10.3 M-106 - General Arrangement Plan At El. 352'-0"
- 10.4 General Arrangement Plan at El. 411'-0"
- 10.5 M-26 P&ID, Sh. 1, Rev. 8, Sh. 3, Rev. 3, Sh. 4, Rev. 3, - Plant Process Radiation Monitoring
- 10.6 EP-242 - Sample Preparation And Handling Of Highly Radioactive Particulate Filters And Iodine Cartridges
- 10.7 EP-243 - Sample Preparation And Handling Of Highly Radioactive Gas Samples

APPENDIX EP-237-1
DATA SHEET

Sample: _____, _____

Analysis: _____, _____

Est. Sampling Time: _____

A. FOR OBTAINING LOCAL PARTICULATE/IODINE SAMPLE

Channel number: _____ (1,2 or 3)
Conc. _____
Range Selection _____ (Low or Mid/High)
Sampling Time _____

A-1 LOW RANGE

Prefilter _____ (A or B)
Time-1 _____
Flow _____ (FI-26-076-2)
Time-2 _____
Prefilter _____ (A or B)
Initial Contact Dose Rate _____

A-2 MID/HIGH RANGE

Prefilter _____ (C or D)
Time-1 _____
Flow _____ (FI-26-076-1)
Time-2 _____
Prefilter _____ (C or D)
Initial Contact Dose Rate _____

B. FOR OBTAINING REMOTE PARTICULATE/IODINE SAMPLE

Channel number: _____ (1,2 or 3)
Conc. _____
Range Selection _____ (Low or Mid/High)
Sampling Time _____

B-1 LOW RANGE

Prefilter _____ (A or B)
Sampling Time _____
Time-1 _____
Flow _____
Time-2 _____
Prefilter _____ (A or B)
Initial Contact Dose Rate _____

B-2 MID/HIGH RANGE

Prefilter _____ (C or D)
Sampling Time _____
Time-1 _____
Flow _____
Time-2 _____
Prefilter _____ (C or D)
Initial Contact Dose Rate _____

C. FOR OBTAINING A GAS GRAB SAMPLE

Time _____
Vol. _____

NAME: _____

*JM Lato 1/20/84*PHILADELPHIA ELECTRIC COMPANY
LIMERICK GENERATING STATION
EMERGENCY PLAN IMPLEMENTING PROCEDUREEP-238 OBTAINING LIQUID RADWASTE SAMPLES FROM RADWASTE SAMPLE
SINK FOLLOWING ACCIDENT CONDITIONS1.0 PURPOSE

The purpose of this procedure is to provide guidelines for consideration, prior to, during and after obtaining samples from the radwaste sample sink, following accident conditions.

2.0 RESPONSIBILITIES

2.1 The Chemistry Sampling and Analysis Group Leader shall direct the group members in performing the steps necessary in this procedure.

3.0 APPENDICES

3.1 EP-238-1 - Data Sheet

4.0 PREREQUISITES

None

5.0 SPECIAL EQUIPMENT

- 5.1 4 oz sample bottle with lid.
- 5.2 Tongs, remote tooling and/or lead carrying container for holding the sample.
- 5.3 Eye Protection.
- 5.4 Plastic bags.
- 5.5 Sample station key.

CONTROLLED**COPIY****VALID ONLY WHEN RED**

6.0 SYMPTOMS

None

7.0 ACTION LEVEL

7.1 This procedure shall be implemented when a Liquid Radwaste sample shall be taken from the Radwaste Sample Sink during an emergency situation.

8.0 PRECAUTIONS

- 8.1 Planned radiation exposures should be limited to the administrative guide levels in Appendix EP-230-1 Emergency Exposure Guidelines.
- 8.2 Eye protection should be worn by all personnel obtaining the sample.
- 8.3 Do NOT use elevators
- 8.4 Continous coverage by a Health Physics Technician may substitute for the Radiation Work Permit (RWP).

9.0 PROCEDURE

9.1 ACTIONS

- 9.1.1 (Interim) Chemistry Sampling and Analysis Team Leader shall:
 - 9.1.1.1 After discussing the situation with the (Interim) Emergency Director, determine if a liquid radwaste sample is required.
 - 9.1.1.2 Determine preference of the Sampling Point from M-23 P&ID, Sheet 1 Process Sampling.
 - 9.1.1.3 Check the Plant Radiation Level Status Board to forecast anticipated radiological conditions.

- 9.1.1.4 Contact the Personnel Safety Team Leader and check on the latest developments related to radiological conditions and inform him what sample(s) are to be taken and that Health Physics' coverage is required.
- 9.1.1.5 Request input from the Control Room (via Emergency Director) to ascertain the desired sample system availability.
- 9.1.1.6 Determine what analyses are required and inform the Chemistry Sampling and Analysis Group Leader what analyses are required.
- 9.1.1.7 Request Emergency Exposure Authorizations from the Emergency Director for Group Members (as required) and inform the Personnel Safety Team Leader of this development.
- 9.1.1.8 Direct the Chemistry Sampling and Analysis Group Leader to collect and analyze the liquid sample from the radwaste sample sink (Radwaste Enclosure 162')
- 9.1.2 Chemistry Sampling and Analysis Group Leader shall:
 - 9.1.2.1 Check with Shift Operations whether a sample can be taken from the desired sample point. (See M-23 P&ID, sheet 1 for reference).
 - 9.1.2.2 Assign the appropriate number of group members to obtain the necessary equipment and collect and transport the sample to the Chemistry Hot Lab.
 - 9.1.2.3 Brief the Chemistry Sampling and Analysis Group members on the following:
 - A. Communications equipment and channel.
 - B. Type of sample(s) to be collected.
 - C. Location of sample points.
 - D. Suggested routes to be taken.
 - E. Sample transport technique.
 - F. Projected amount of time required to collect and transport the sample.

- G. Review of the procedures to be followed for sample collection, handling, preparation and analysis.
- H. Special tools and equipment required for sample handling and/or collection.
- I. Proper completion of Data Sheets.

9.1.2.4 Appoint one Group member to prepare the Hot Lab for receiving the sample.

USE THE FOLLOWING PROCEDURES AS GUIDELINES FOR PREPARATION OF THE HOT LAB.

EP-241 (LIQUID) Sample Preparation and Handling of Highly Radioactive Liquid Samples

EP-242 (IODINE) Sample Preparation and Handling of Highly Radioactive Particulate Filters and Iodine Cartridges

EP-243 (GAS) Sample Preparation and Handling of Highly Radioactive Gas Samples

9.1.2.5 Dispatch the Chemistry Sampling and Analysis Team Members to the OSC for Health Physics Support if radiological conditions permit or other appointed location as determined by the Plant Survey Group Leader.

9.1.3 The Health Physics Technician shall:

9.1.3.1 Select the appropriate sample route.

9.1.3.2 Take appropriate radiation survey equipment and ensure that equipment is functional and calibrated.

9.1.3.3 Provide Group Members with the appropriate dosimetry, protective clothing and respiratory equipment.

9.1.3.4 Perform a pre-job briefing with the Chemistry technicians assigned to obtain sample to discuss the following:

- A. RWP requirements
- B. Routes to be used
- C. Authorized doses
- D. Radiological concerns and precautions
- E. Review of procedure for obtaining and transporting sample to hot lab
- F. Suggested methods to maintain exposure ALARA
- G. Stay times and Abort Criteria

9.1.3.5 Provide constant coverage while obtaining, transporting and analyzing the sample with the Containment Leak Detector.

9.1.3.6 Monitor dose rates enroute and at the location. Upon entering the power block surveyors will note trends in general radiation levels enroute to the Containment Leak Detector. If general area dose rate (unanticipated) exceeds 10 R/hr gamma rad/hr beta prior to arriving at the point specified below, exit immediately and report to Chemistry Sampling and Analysis Group Leader.

If the general area dose rate (unanticipated) exceeds 5 R/hr at the door leading to Rx. 162', leave the area immediately and report to Chemistry Sampling and Analysis Group Leader with this information.

9.1.3.7 Survey the sample area and sample cask.

9.1.3.8 Document the sample cask survey results and give them to the Chemistry Sampling and Analysis Group Leader (or other designated group member) when arriving at the hot lab.

9.1.3.9 Provide constant coverage during sample preparation and handling as specified in EP-241.

sample
work the
containment
rates
a or 10
point
report
cup

door
Sampling

hot lab.

in EP-

- 9.1.4 Chemistry Sampling and Analysis Group members shall:
- 9.1.4.1 Assemble for a pre-job briefing at the chemistry lab.
- 9.1.4.2 Inform the Group Leader if they are approaching the administrative exposure guidelines, or may not have sufficient exposure remaining to successfully complete the assigned task.
- 9.1.4.3 Obtain the necessary equipment to collect the sample and ensure that the hot lab is ready to accept the sample.

PROPERLY LABEL ALL SAMPLE CONTAINERS

- 9.1.4.4 Once the group has been briefed and the appropriate equipment has been assembled, proceed to the OSC or other designated location for HP support. Once briefed by Health Physics, collect the sample as follows:
- A. Proceed to the Radwaste Sample Sink.
- B. Have the H.P. Technician survey the area, concentrating on the Sample Sink
- C. Proceed to the predetermined Grab Sample Point.
- D. Ensure that a flow is present. If not, attempt to initiate flow by opening root valves. If flow is not established, exit and consult Chemistry Sampling and Analysis Group Leader.
- E. SAMPLING METHOD Obtain a 2 oz. sample (or less if activity is extreme) in a 4 oz bottle. Use tongs or other remote handling tools for sample collection if required. When required amount of sample is obtained remove bottle and transport with tongs, other remote tools, or lead carrying container.
- F. Have the Health Physics Technician survey the vial and record the Initial Contact Dose Rate in Appendix EP-235-1.

- G. Complete the Data Sheet in Appendix EP-238-1.
- H. Take the sample to the Hot Lab.

9.2 FOLLOW-UP

- 9.2.1 Chemistry Sampling and Analysis Group Members shall:
 - 9.2.1.1 Prepare, handle and analyze the sample using EP-241 Preparation and Handling of Highly Radioactive Liquids.
 - 9.2.1.2 Report the results to the Chemistry Sampling and Analysis Group Leader.
 - 9.2.1.3 Properly file the data sheets and report back to the Group Leader for reassignment.
 - 9.2.1.4 Return all sampling equipment to the CHEMISTRY EMERGENCY CABINET.
- 9.2.2 Chemistry Sampling and Analysis Group Leader shall:
 - 9.2.2.1 Ensure Group Member(s) dose is monitored to ensure that exposure limits have not been exceeded.
 - 9.2.2.2 Inform the Chemistry Sampling and Analysis Team Leader that the required sample is in the hot lab.
 - 9.2.2.3 Direct Group Members to refer to EP-241 Sample Preparation and Handling of Radioactive Liquids for guidance for sample preparation and handling.
 - 9.2.2.4 Obtain and review all Data Sheets and report the sample results to the Chemistry Sampling and Analysis Team Leader and attach all Data Sheets to Appendix EP-230-2.
 - 9.2.2.5 Obtain sample station key from Group Member.
- 9.2.3 Chemistry Sampling and Analysis Team Leader shall:
 - 9.2.3.1 Report the results to the Emergency Director and the Health Physics and Chemistry Coordinator (EOF).

10.0 REFERENCES

- 10.1 EP-230 Chemistry Sampling and Analysis Team Activation
- 10.2 M-23 P&ID, Sh. 1 Rev. 9 Process Sampling
- 10.3 M-100 General Arrangement Plan at El. 177'-0"
- 10.4 M-102 General Arrangement Plan at El. 217'-0"
- 10.5 EP-241 Sample Preparation and Handling of Highly
Radioactive Liquids

APPENDIX EP-238-1

DATA SHEET

Liquid Radwaste Grab Samples

DATE: _____

TIME: _____

SAMPLE LOCATION: _____

SAMPLE POINT: _____

VOLUME: _____

INITIAL CONTACT DOSE RATE: _____

ANALYSES REQUIRED: _____

NAME: _____

JM Litch 1/20/84

PHILADELPHIA ELECTRIC COMPANY
LIMERICK GENERATING STATION
EMERGENCY PLAN IMPLEMENTING PROCEDURE

EP-241

SAMPLE PREPARATION AND HANDLING OF HIGHLY RADIOACTIVE LIQUID SAMPLES.

1.0 PURPOSE

The purpose of this procedure is to provide guidelines for sample preparation and handling of highly radioactive liquid samples following accident conditions.

2.0 RESPONSIBILITIES

2.1 The Chemistry Sampling and Analysis Group Leader is responsible for:

- a. Determining the processing procedure.
- b. Determining the method and location of sample storage and/or disposal as required.
- c. Having group member(s) exposure monitored in conjunction with Health Physics guidance to ensure that the Administrative Exposure Guidelines are not exceeded.
- d. Directing group member(s) and the assigned Health Physics technician to perform the necessary steps of this procedure and to report back the results of the sample analysis as soon as they become available.

2.2 The Health Physics technician is responsible for:

- a. Providing constant coverage for the necessary steps of this procedure.
- b. Monitoring the extremity dose to the hands during sample handling.
- c. Monitoring laboratory habitability.
- d. Conducting a pre-job briefing concerning :
 1. RWP requirements.

VALID ONLY WHEN RE

2. Radiological concerns and precautions (ALARA).
3. The use of staytimes to ensure that exposures do not exceed limits.

2.3 The Chemistry Sampling and Analysis Group members are responsible for:

- a. Preparing the hot lab post accident sample preparation station to accept the sample.
- b. Performing sample dilution and analysis requirements as specified by the Chemistry Sampling and Analysis Group Leader.
- c. Following RWP and Health Physics requirements as specified by the Health Physics technician.

3.0 APPENDICES

3.1 EP-241-1 Data Sheet

4.0 PREREQUISITES

4.1 Ventilation in the sample preparation hood is operating.

5.0 SPECIAL EQUIPMENT

- 5.1 Liquid sample vials with septum.
- 5.2 Appropriate liquid microsyringes.
- 5.3 Rubber gloves
- 5.4 Plastic sample bags.
- 5.5 Sample handling tongs.
- 5.6 0.01N nitric acid solution(500 ml).
- 5.7 Eye protection

6.0 SYMPTOMS

None

7.0 ACTION LEVEL

7.1 This procedure shall be implemented when preparing or handling highly radioactive liquid samples during an emergency situation.

8.0 PRECAUTIONS

8.1 In all steps of this procedure, keep exposures ALARA.

9.0 PROCEDURE

9.1 ACTIONS

9.1.1 Determination of processing procedure.

9.1.1.1 The Chemistry Sampling and Analysis Group Leader shall obtain the appropriate EP-Sample Data Sheet and select one of the following processing procedures based on the radiation levels of the sample.

- a. Send the sample off-site for analysis per EP-244 Offsite Analysis of High Activity Samples.
- b. Place the sample in temporary storage for future analysis.
- c. Analyze the sample on-site.

COMPLETE SECTION I OF APPENDIX EP-241-1

9.1.1.2 The Chemistry Sampling and Analysis Group Leader shall determine the following sample parameters based on sample dose rates and analysis requirements.

- a. Analysis to be performed.
- b. Order of analysis

- c. Number and magnitude of dilutions
- d. Analysis sample volume desired

PH DETERMINATION CANNOT BE PERFORMED ON DILUTED SAMPLES.

COMPLETE SECTION II OF APPENDIX EP-241-1.

9.1.2

Pre-Job Briefing

9.1.2.1

The Chemistry Sampling and Analysis Group Leader, Health Physics Technician and the Chemistry Sampling and Analysis Group Members shall assemble and review this procedure.

9.1.2.2

The Chemistry Sampling and Analysis Group Leader shall direct group members to perform the necessary steps of this procedure.

SECTION 9.1.3 AND 9.1.4 SHOULD BE PERFORMED AS EARLY AS POSSIBLE. THE SAMPLE MAY NOT BE PLACED IN THE SAMPLE PREPARATION STATION UNTIL THESE SECTIONS HAVE BEEN COMPLETED.

9.1.2.3

The Health Physics Technician shall brief group members on:

- a. RWP requirements
- b. Radiological concerns and precautions (ALARA)
- c. Staytimes and exposure limits

9.1.3

Preparation of sample preparation station for liquid samples

9.1.3.1

The Chemistry Sampling and Analysis Group Member(s) shall prepare the dilution vials (with appropriate labels) per appendix EP-241-1 and place the vials in the appropriate dilution vial positions in the sample preparation station. Place lead caps over the vials (liquid position).

THE LEAD CAPS MAY BE POSITIONED FOR GAS OR LIQUID SAMPLES. FOR THE PURPOSE OF THIS PROCEDURE THEY SHALL BE IN THE LIQUID POSITION

- 9.1.3.2 The Chemistry Sampling and Analysis Group Member(s) shall ensure that the necessary liquid micro syringes (with needles), sample handling tongs and sample analysis containers are in place and available to fulfill dilution and analysis requirements per appendix EP-241-1.
- 9.1.3.3 The Chemistry Sampling and Analysis Group Member(s) shall ensure that at least one pair of plastic gloves and two plastic sample bags are available for each gamma analysis to be performed.
- 9.1.4 Preparation of analysis instrumentation.
- 9.1.4.1 The Chemistry Sampling and Analysis Group Member(s) shall insure that the appropriate analysis procedures specified in appendix EP-241-1 are available and have been performed to the point that each analysis instrument is ready to accept the sample for analysis.

THE FOLLOWING STEPS ARE TO BE PERFORMED BY THE CHEMISTRY SAMPLING AND ANALYSIS GROUP MEMBER(S) (UNLESS OTHERWISE SPECIFIED) AND REQUIRE CONSTANT HEALTH PHYSICS MONITORING.

LEAD BRICKS IN THE SAMPLE PREPARATION STATION HAVE BEEN MODIFIED TO ACCEPT THE SAMPLE. THE LEAD BRICK LABELED "SAMPLE VIAL A" HAS BEEN MODIFIED TO ACCEPT A GAS OR LIQUID SAMPLE FROM THE PASS. THE LEAD BRICK LABELED "SAMPLE VIAL B" HAS BEEN MODIFIED TO ACCEPT A LIQUID SAMPLE FROM THE REACTOR COOLANT SAMPLE STATION.

- 9.1.5 Transport of sample from transport cask to sample preparation station.
- 9.1.5.1 Remove the lead cap from the lead brick to accept the sample.
- 9.1.5.2 Position the sample transport cask as close to the Sample Preparation Station as possible.
- 9.1.5.3 As quickly and carefully as is possible, remove the sample from the transport cask and place it in the lead brick.

- 9.1.5.4 Quickly place the lead cap over the sample in the "liquid" position.
- 9.1.5.5 Retreat from the Sample Preparation Station and allow the Health Physics Technician to take dose rate readings.

THE HEALTH PHYSICS TECHNICIAN SHALL INFORM THE CHEMISTRY SAMPLING AND ANALYSIS GROUP MEMBER OF THE SAMPLE PREPARATION STATION DOSE RATES AND STAY TIME.

- 9.1.6 Sample Dilution (if dilutions are not to be performed, proceed to step 9.1.7).

DILUTIONS TO BE MADE ARE DESCRIBED IN APPENDIX EP-241-1. ALL ACCESSORIES USED IN THE DILUTION PROCESS SHALL BE MAINTAINED BEHIND THE LEAD SHIELD WALL ONCE THEY HAVE BEEN CONTAMINATED.

- 9.1.6.1 Insert the syringe thru the sample access hole in the lead cap then thru the sample vial septum and into the sample to be diluted. Withdraw the predetermined (appendix EP-241-1) aliquot from the sample vial.
- 9.1.6.2 Withdraw the syringe from the sample and insert it in the prescribed method into the next sequential dilution vial to accept the sample (Dilution Vial #1, #2 etc.). Inject the aliquot into the dilution vial.
- 9.1.6.3 Withdraw the syringe from the sample. Separate the needle and the syringe and discard them in the shielded waste container.
- 9.1.6.4 Remove the lead cap over the diluted sample. Grasp the sample vial securely with the sample handling tongs and raise the vial out of the lead brick (but not above the lead shield wall).
- 9.1.6.5 Using the tongs, swirl the sample vial enough to ensure adequate mixing, replace the vial. Replace the lead cap (liquid position).
- 9.1.6.6 If further dilutions are necessary (per appendix EP-241-1) repeat steps 9.1.6.1 thru 9.1.6.5, always beginning with the last dilution vial to accept a sample aliquot.

- 9.1.6.7 When desired dilution is reached, the Health Physics Technician shall determine the dose rate of the diluted sample.
- 9.1.6.8 If the diluted sample dose rate is unacceptable, repeat steps 9.1.6.1 thru 9.1.6.5 until dose rate is acceptable. Indicate additional dilutions on appendix EP-241-1.
- 9.1.7 Sample Cup Preparation
- 9.1.7.1 For each analysis to be performed (appendix EP-241-1) use the syringe transfer method (step 9.1.6.1) to sequentially obtain the volume of sample required (Appendix EP-241-1) from the appropriate diluted/undiluted sample source (appendix EP-241-1).
- 9.1.7.2 Inject the appropriate sample aliquot into its analysis cup.

DUE TO THE AMOUNT OF SAMPLE BEING REMOVED FROM THE BOTTLE IT MAY BE NECESSARY TO VENT THE BOTTLE BY PLACING A NEEDLE THRU THE SEPTUM.

DUE TO THE SMALL VOLUME OF SAMPLE USED TO PERFORM PH AND THE EFFECTS CO₂ ABSORPTION WILL HAVE ON THE ANALYSIS, THE PH SHOULD BE DETERMINED IMMEDIATELY AFTER THE SAMPLE IS PLACED IN ITS SAMPLE CUP.

9.2 FOLLOW-UP

- 9.2.1 Perform the predetermined analysis (Appendix EP-241-1) in the predetermined sequence (Appendix EP-241-1).
- 9.2.2 Disposal of samples and contaminated materials

THE STORAGE AND/OR DISPOSAL OF THE UNUSED PORTION OF THE ORIGINAL SAMPLE WILL BE AT THE DISCRETION OF THE CHEMISTRY SAMPLING AND ANALYSIS GROUPS LEADER AND THE HEALTH PHYSICS TECHNICIAN.

- 9.2.2.1 The remaining samples and contaminated sample cups shall be disposed of in the shielded waste container. The sample handling tongs shall be used in the transfers. The samples and sample cups should be kept behind the lead shield wall as much as is possible.

9.2.2.2 Transfer and disposal of the shielded waste container will be at the discretion of the Health Physics Technician and the Chemistry Sampling and Analysis Group Leader.

10.0 REFERENCES

- 10.1 CH-901 Determination of Ions by Ion Chromatograph during Post Accident Conditions.
- 10.2 CH-903 Determination of PH in Low Volume Water Samples during Post Accident Conditions.
- 10.3 Ch-904 Determination of Metals by DCP during Post Accident Conditions.
- 10.4 CH-905 Determination of Gamma Isotopic activity during Post Accident Conditions.
- 10.5 Ch-906 Determination of chloride by Specific ton during Post Accident Conditions.
- 10.6 CH-907 Determination of Boron at ppm levels during Post Accident Conditions.
- 10.7 EP-230 Chemistry Sampling and Analysis Team Activation

Appendix EP-241-1
Data Sheet

I.
Sample Source _____
Grab Sample Point _____
Initial Sample Volume _____
Initial Contact Dose Rate _____
Sample Date/Time _____/_____
II.

Processing Procedure:
A. Sent Offsite for Analysis(1) (X
B. Placed in Temporary Storage (1),(2) (
C. Analyzed on Site (

Order of Analysis	Analysis	Procedure Number	(3) Magnitude of Dilutions	Number of Dilutions	Total Dilution Factor	(4) Analysis Sample Volume	Acceptable Analysis Dose Rate
1	_____	_____	_____	_____	_____	_____	_____
2	_____	_____	_____	_____	_____	_____	_____
3	_____	_____	_____	_____	_____	_____	_____
4	_____	_____	_____	_____	_____	_____	_____
5	_____	_____	_____	_____	_____	_____	_____
6	_____	_____	_____	_____	_____	_____	_____

- (1) If this method is used sign and date this data sheet and terminate this procedure.
- (2) The Chemistry Sampling and Analysis Group Leader shall determine place of storage.
- (3) Magnitude of Dilutions (4) Analysis Sample Volume

10:1 = 1 ml sample: 9 ml of 0.01N Nitric Acid
 100:1 = 1 ml sample: 9.9 ml of 0.01 Nitric Acid
 1000:1 = 0.01 ml sample: 9.99 ml of 0.01N Nitric Acid

pH 0.5ml Cl (IC) 4 ml
 B (DCP) 4 ml (SIE) 1 ml

Due to the complexity of the dilution and analysis process, it is recommended that the same magnitude of dilution be used for all of the analysis.

MDL's for: Boron Chloride
 DCP 10ppb IC 1ppb
 Titr. 1ppm SIE 1ppm

Reactor Coolant Regions of Interest Activity
 Activity - 10 uCi/cc to 10 Ci/cc
 Borod - 50 ppm to 1100 ppm
 Chloride - greater than 10 ppm

Chemistry Group Leader _____ / _____

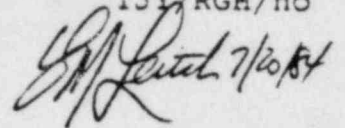
PHILADELPHIA ELECTRIC COMPANY
LIMERICK GENERATING STATION
EMERGENCY PLAN IMPLEMENTING PROCEDUREEP-242 SAMPLE PREPARATION AND HANDLING OF HIGHLY RADIOACTIVE
PARTICULATE FILTERS AND IODINE CARTRIDGES1.0 PURPOSE

The purpose of this procedure is to provide guidelines for sample preparation and handling of highly radioactive particulate filters and iodine cartridges during an emergency situation.

2.0 RESPONSIBILITIES

- 2.1 The Chemistry Sampling and Analysis Group Leader is responsible for:
- 2.1.1 Determining the processing procedure.
 - 2.1.2 Determining the method and location of sample storage and/or disposal as required.
 - 2.1.3 Having group member(s) exposure monitored in conjunction with Health Physics guidance to ensure that the Administrative Exposure Guidelines are not exceeded.
 - 2.1.4 Directing Group Member(s) and the assigned Health Physics technician to perform the necessary steps of this procedure and to report back the results of the sample analysis as soon as they become available.
- 2.2 The Health Physics technician is responsible for:
- 2.2.1 Providing constant coverage for the necessary steps of this procedure.
 - 2.2.2 Monitoring the extremity dose to the hands during sample handling.
 - 2.2.3 Monitoring laboratory habitability.

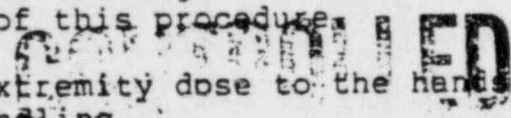
VALID ONLY WHEN RED

2.2.4 Conducting a pre-job briefing concerning:

- A. RWP requirements
- B. Radiological concerns and precautions
- C. The use of staytimes to ensure that exposures do not exceed limits.

2.3 The Chemistry Sampling and Analyses Group Members are responsible for:

2.3.1 Preparing the hot lab post-accident sample preparation station to accept the sample.

2.3.2 Following sample dilution and analysis requirements as specified by the Chemistry Sampling and Analyses Group Leader

2.3.3 Following RWP and Health Physics requirements as specified by the Health Physics technician.

3.0 APPENDICES

3.1 EP-242-1 Data Sheet

4.0 PREREQUISITES

4.1 Ventilation in the sample preparation hood is operating.

5.0 SPECIAL EQUIPMENT

5.1 Purge cannister

5.2 Eye protection

5.3 Plastic sample bags

5.4 Sample handling tongs

6.0 SYMPTOMS
None

7.0 ACTION LEVEL
7.1 This procedure shall be implemented when preparing or handling highly radioactive particulate filters and iodine cartridges during an emergency situation.

8.0 PRECAUTIONS
8.1 In all steps of this procedure, keep exposures ALARA.

9.0 PROCEDURE
9.1 ACTIONS
9.1.1 Determination of Processing Procedure
9.1.1.1 The Chemistry Sampling and Analyses Group Leader shall obtain the appropriate Sample Data Sheet and select one of the following processing procedures based on the radiation levels of the sample.
A. Send the sample offsite for analyses per EP-244 Offsite Analysis of High Activity Samples.
B. Place the sample in temporary storage for future analyses.
C. Analyze the sample on-site.

9.1.1.2 COMPLETE SECTION I OF APPENDIX EP-242-1.
The Chemistry Sampling and Analyses Group Leader shall determine the following sample parameters based on sample dose rates and gamma isotopic analyses requirements.

- A. Sample to be analyzed (silver zeolite and/or filter)
- B. Order of analyses
- C. Purge time of sample
- D. Acceptable dose rate for gamma counting

COMPLETE SECTION II OF APPENDIX EP-243-1.

9.1.2 Pre-Job Briefing

9.1.2.1 The Chemistry Sampling and Analyses Group Leader, Health Physics technician and the Chemistry Sampling and Analyses Group Members shall assemble and review this procedure.

9.1.2.2 The Chemistry Sampling and Analyses Group Leader shall direct group members to perform the necessary steps of this procedure.

SECTION 9.1.3 AND 9.1.4 SHOULD BE PERFORMED AS EARLY AS POSSIBLE. THE SAMPLE MAY NOT BE PLACED IN THE SAMPLE PREPARATION STATION UNTIL THESE SECTIONS HAVE BEEN COMPLETED.

9.1.2.3 The Health Physics technician shall brief group members on:

- A. RWP requirements
- B. Radiological concerns and precautions (ALARA)
- C. Staytimes and exposure limits

NOTE

THE FOLLOWING STEPS ARE TO BE PERFORMED BY THE CHEMISTRY SAMPLING AND ANALYSIS GROUP MEMBER (UNLESS OTHERWISE SPECIFIED).

- 9.1.3 Preparation of Sample Station for Iodine and Particulate Samples
- 9.1.3.1 Determine the purge gas to be used (nitrogen or air)

- 9.1.3.2 Ensure that the desired purge gas system has adequate supply pressure and is aligned to the sample preparation station.
- 9.1.3.3 Place the purge cannister discharge line in the "discharge position".
- 9.1.3.4 If a purge cannister is to be used connect it to the quick disconnect fitting and place it behind the lead shield wall.
- 9.1.4 Preparation of Analysis Instrumentation
 - 9.1.4.1 Ensure that the appropriate analysis procedure specified in Appendix EP-242-1 is available and has been performed to the point that each analysis instrument is ready to accept the sample for analysis.

NOTE

CONSTANT HP COVERAGE IS REQUIRED BEFORE PROCEEDING.

- 9.1.5 Transport of Sample from Transport Cask to Sample Preparation Station
 - 9.1.5.1 Position the sample transport cask as close to the Sample Preparation Station as possible.
 - 9.1.5.2 As quickly and carefully as possible, remove the sample from the transport cask and place it behind the lead shield wall.
 - 9.1.5.3 If a purge cannister is to be used, place the sample in its appropriate purge cannister and connect the quick disconnect fittings. Establish a purge gas flow in the same direction as was used in the sampling process.
 - 9.1.5.4 If a purge cannister is not used, connect the quick disconnect fittings (on the sample chamber). Establish a purge gas flow in the same direction and flow rate as was used in the sampling process.

- 9.1.5.5 Retreat from the Sample Preparation Station and allow the sample to purge for the predetermined amount of time (Appendix EP-242-1).
- 9.1.5.6 When the desired purge time has elapsed secure the purge gas and disconnect the quick disconnect fittings. Keep the sample shielded behind the lead shield wall.
- 9.1.5.7 The Health Physics technician shall determine the dose rate of the purged sample.
- 9.1.5.8 If the purged sample dose rate is unacceptable (per Appendix EP-242-1) repeat steps 9.1.5.3 through 9.1.5.7 until the acceptable analysis dose rate is reached or no longer changes.

9.2 FOLLOW-UP

- 9.2.1 Sample Analyses
 - 9.2.1.1 Perform the gamma isotopic analysis as directed in Appendix EP-242-1.
- 9.2.2 Disposal of Samples and Contaminated Materials
 - 9.2.2.1 Transfer and disposal of "analyzed samples" will be at the discretion of the Health Physics technician and the Chemistry Sampling and Analysis Group Leader.

10.0 REFERENCES

- 10.1 CH-905 Determination of Gamma Isotopic Activity During Post Accident Conditions
- 10.2 EP-230 Chemistry Sampling and Analysis Team Activation

APPENDIX EP-242-1

DATA SHEET

I. Sample Source _____ Grab Sample Point _____
 Initial Sample Volume _____ Initial Contact Dose Rate _____
 Sample Date/Time _____/_____

Processing Procedure: (X)

(*) A. Sent offsite for analyses ()

(*)(**) B. Placed in temporary storage ()

C. Analyzed on-site ()

(*) If this method is used, sign and date this data sheet and terminate this procedure.

(**) The Chemistry Sampling and Analyses Group Leader shall determine the place of storage.

II. Gamma Isotopic Analysis requirements

<u>Order of Analysis</u>	<u>Procedure Number</u>	<u>(***) Sample to be Analyzed</u>	<u>(****) Purge Time</u>	<u>Acceptable Dose Rate for Analysis</u>
1	CH-905	_____	_____	_____
2	CH-905	_____	_____	_____

(***) silver zeolite cartridge(s), charcoal cartridges, or filter paper

(****) since all samples are to be purged together, the same purge time should be used.

Signature _____ Date _____ Time _____

Chemistry Group Member _____

Health Physics Group Member _____

Group Leader _____

J. R. Reed 7/20/84

PHILADELPHIA ELECTRIC COMPANY
LIMERICK GENERATING STATION
EMERGENCY PLAN IMPLEMENTING PROCEDURE

EP-243 SAMPLE PREPARATION AND HANDLING OF HIGHLY RADIOACTIVE GAS SAMPLES

1.0 PURPOSE

The purpose of this procedure is to provide guidelines for sample preparation and handling of highly radioactive gas samples following accident conditions.

2.0 RESPONSIBILITIES

- 2.1 The Chemistry Sampling and Analysis Group Leader is responsible for:
- 2.1.1 Determining the processing procedure.
 - 2.1.2 Determining the method and location of sample storage and/or disposal as required.
 - 2.1.3 Having group member(s) exposure monitored in conjunction with Health Physics guidance to ensure that the Administrative Exposure Guidelines arenct exceeded.
 - 2.1.4 Directing Group Member(s) and the assigned Health Physics technician to perform the necessary steps of this procedure and to report back the results of the sample analysis as soon as they become available.
- 2.2 The Health Physics technician is responsible for:
- 2.2.1 Providing constant coverage for the necessary steps of this procedure.
 - 2.2.2 Monitoring the extremity dose to the hands during sample handling.
 - 2.2.3 Monitoring laboratory habitability.

CONTROLLED
VALID ONLY WHEN RED

2.2.4 Conducting a pre-job briefing concerning:

- A. RWP requirements
- B. Radiological concerns and precautions
- C. The use of staytimes to ensure that exposures do not exceed limits.

2.3 The Chemistry Sampling and Analyses Group Members are responsible for:

2.3.1 Preparing the hot lab post-accident sample preparation station to accept the sample.

2.3.2 Performing sample dilution and analysis requirements as specified by the Chemistry Sampling and Analyses Group Leader

2.3.3 Following RWP and Health Physics requirements as specified by the Health Physics technician.

3.0 APPENDICES

3.1 EP-243-1 Data Sheet

4.0 PREREQUISITES

4.1 Ventilation in the sample preparation hood is operating.

5.0 SPECIAL EQUIPMENT

5.1 Gas sample vials

5.2 Appropriate gas syringes

5.3 Rubber gloves

5.4 Plastic sample bags

5.5 Sample handling tongs

5.6 Eye protection

6.0 SYMPTOMS

None

7.0 ACTION LEVEL

7.1 This procedure shall be implemented when preparing or handling highly radioactive gas sample during an emergency situation.

8.0 PRECAUTIONS

8.1 In all steps of this procedure keep exposures ALARA.

9.0 PROCEDURE

9.1 ACTIONS

9.1.1 Determination of Processing Procedure

9.1.1.1 The Chemistry Sampling and Analyses Group Leader shall obtain the appropriate EP-Sample Data Sheet and select one of the following processing procedures based on the radiation levels of the sample.

A. Send the sample offsite for analyses per EP-244 Offsite Analysis of High Activity Samples.

B. Place the sample in temporary storage for future analyses.

C. Analyze the sample on-site.

COMPLETE SECTION I OF APPENDIX EP-243-1.

9.1.1.2 The Chemistry Sampling and Analyses Group Leader shall determine the following sample parameters based on sample dose rates and analysis requirements.

A. Analysis to be performed

B. Order of analyses

C. Number and magnitude of dilutions

D. Analyses sample volume required.

SAMPLES FOR HYDROGEN AND OXYGEN
DETERMINATION BY GAS CHROMATOGRAPHY MUST NOT
BE DILUTED.

COMPLETE SECTION II OF APPENDIX EP-243-1.

9.1.2 Pre-Job Briefing

9.1.2.1 The Chemistry Sampling and Analyses Group
Leader, Health Physics technician and the
Chemistry Sampling and Analyses Group
Members shall assemble and review this
procedure.

9.1.2.2 The Chemistry Sampling and Analyses Group
Leader shall direct group members to perform
the necessary steps of this procedure.

SECTION 9.1.3 AND 9.1.4 SHOULD BE PERFORMED
AS EARLY AS POSSIBLE. THE SAMPLE MAY NOT BE
PLACED IN THE SAMPLE PREPARATION STATION
UNTIL THESE SECTIONS HAVE BEEN COMPLETED.

9.1.2.3 The Health Physics technician shall brief
group members on:

A. RWP requirements

B. Radiological concerns and precautions
(ALARA)

C. Staytimes and exposure limits

9.1.3 Preparation of Sample Preparation Station
for Gas Samples

9.1.3.1 The Chemistry Sampling and Analysis Group
Member(s) shall prepare the dilution vials
per Appendix EP-243-1 and place the vials in
the appropriate dilution vial positions in
the sample preparation station. Each
dilution vial shall have the predetermined
(EP-243-1) aliquot volume withdrawn from it.
Place lead caps over the vials (gas
position).

THE LEAD CAPS MAY BE POSITIONED FOR GAS OR LIQUID SAMPLES. FOR THE PURPOSE OF THIS PROCEDURE THEY SHALL BE IN THE GAS POSITION.

- 9.1.3.2 The Chemistry Sampling and Analyses Group Member(s) shall ensure that the necessary gas micro syringes (with needles), sample handling tongs and sample analysis containers are in place and available to fulfill dilution and analysis requirements per Appendix EP-243-1.
- 9.1.3.3 The Chemistry Sampling and Analysis Group Member(s) shall ensure that at least one pair of plastic gloves and two plastic sample bags are available for each gamma analysis to be performed.
- 9.1.4 Preparation of Analysis Instrumentation
 - 9.1.4.1 The Chemistry Sampling and Analysis Group Member(s) shall ensure that the appropriate analyses procedures specified in Appendix EP-243-1 are available and have been performed to the point that each analysis instrument is ready to accept the sample for analysis.

THE FOLLOWING STEPS ARE TO BE PERFORMED BY THE CHEMISTRY SAMPLING AND ANALYSES GROUP MEMBER (UNLESS OTHERWISE SPECIFIED) AND REQUIRE CONSTANT HEALTH PHYSICS MONITORING.

LEAD BRICKS IN THE SAMPLE PREPARATION STATION HAVE BEEN MODIFIED TO ACCEPT THE SAMPLE. THE LEAD BRICK LABELED "SAMPLE VIAL A" HAS BEEN MODIFIED TO ACCEPT A GAS OR LIQUID SAMPLE FROM THE PASS!

- 9.1.5 Transport of Sample from Transport Cask to Sample Preparation Station
 - 9.1.5.1 Remove the lead cap from the lead brick to accept the sample.
 - 9.1.5.2 Position the sample transport cask as close to the Sample Preparation Station as possible.
 - 9.1.5.3 As quickly and carefully as is possible, remove the sample from the transport cask and place it in the lead brick.

9.1.5.4 Quickly place the lead cap over the sample in the "gas position".

9.1.5.5 Retreat from the Sample Preparation Station and allow the Health Physics technician to take dose rate readings.

THE HEALTH PHYSICS TECHNICIAN SHALL INFORM THE CHEMISTRY SAMPLING AND ANALYSIS GROUP MEMBERS OF THE SAMPLE PREPARATION STATION DOSE RATES AND STAY-TIME.

9.1.6 Sample Dilutions (If dilutions are not to be performed or if analyses are to be performed prior to dilution, proceed to 9.2.1.2).

DILUTIONS TO BE MADE ARE PRESCRIBED IN APPENDIX EP-243-1. ALL ACCESSORIES USED IN THE DILUTION PROCESS SHALL BE MAINTAINED BEHIND THE LEAD SHIELD WALL ONCE THEY HAVE BEEN CONTAMINATED.

9.1.6.1 Insert the syringe through the sample access hole in the lead cap, then through the sample vial septum and into the sample to be diluted.

9.1.6.2 Mix the gas in the sample vial by pumping the syringe in and out.

9.1.6.3 Set the syringe to the volume of sample to be transferred per Appendix EP-243-1.

9.1.6.4 Withdraw the syringe from the sample and insert it in the predescribed method into the next sequential dilution vial to accept the sample. Inject the aliquot into the dilution vial.

9.1.6.5 Mix the gas in the sample vial by pumping the syringe in and out.

9.1.6.6 Withdraw the syringe from the sample. Separate the needle and the syringe and discard them in the shielded waste container.

9.1.6.7 If further dilutions are necessary (per Appendix EP-243-1) repeat steps 9.1.6.1 through 9.1.6.6, always beginning with the last dilution vial to accept a sample aliquot.

- 9.1.6.8 When the desired dilution is reached, the Health Physics technician shall determine the dose rate of the dilution sample.
- 9.1.6.9 If the dilution sample dose rate is unacceptable repeat steps 9.1.6.1 through 9.1.6.6 until the dose rate is acceptable. Indicate additional dilutions on Appendix EP-241-1.

9.2 FOLLOW-UP

9.2.1 Sample Analysis

- 9.2.1.1 Perform gamma isotopic analysis if directed by Appendix EP-243-1. Proceed to step 9.2.2.
- 9.2.1.2 Perform oxygen and hydrogen analysis if directed by Appendix EP-243-1. Proceed back to step 9.1.6.1 if dilutions are necessary for gamma isotopic analysis per Appendix EP-243-1.
- 9.2.2 Disposal of Samples and Contaminated Materials
- 9.2.2.1 The remaining samples shall be disposed of in the shielded waste container. The sample handling tongs shall be used in the transfer. The samples should be kept behind the lead shield wall as much as is possible.
- 9.2.2.2 Transfer and disposal of the shielded waste container will be at the discretion of the Health Physics technician and the Chemistry Sampling and Analyses Group Leader.

10.0 REFERENCES

- 10.1 CH-905 Determination of Gamma Isotopic Activity During Post Accident Conditions
- 10.2 CH-902 Determination of Hydrogen and Oxygen Using a Gas Chromatograph During Post Accident Conditions
- 10.3 EP-230 Chemistry Sampling and Analysis Team Activation

APPENDIX EP-243-1
DATA SHEET (CONT'D)

(***) Due to the complexity of the dilution and analysis process it same magnitude of dilution be used for all of the analyses. of dilution use the following tables: (*****) Recommended s micro liters

<u>Aliquot Size</u>	<u>1st dilution</u>	<u>2nd dilution</u>	<u>3rd dilution</u>
1 ml	14.4	207	2985
.1 ml	144	2070	29850

$$\text{Total Dilution Factor} = \frac{V_s}{14.4} \times \text{Magnitude of Dilution}$$

Vs = Volume of original sample (from the appropriate EP Sample Data

Signature

APPENDIX EP-243-1

DATA SHEET

I. Sample Source _____ Grab Sample Point _____
 Initial Sample Volume _____ Initial Contact Dose Rate _____
 Sample Date/Time _____/_____

Processing Procedure: (X)

(*) A. Sent offsite for analyses ()

(*)(**) B. Placed in temporary storage ()

C. Analyzed on-site ()

(*) If this method is used, sign and date this data sheet and ter

(**) The Chemistry Sampling and Analyses Group Leader shall determ

II.

Order of Analyses	Analysis	Procedure Number	Aliquot Size	*** Magnitude of Dilutions	**** Total Dilution Factor
1	_____	_____	_____	__ __ __ __	_____
2	_____	_____	_____	__ __ __ __	_____
3	_____	_____	_____	__ __ __ __	_____
4	_____	_____	_____	__ __ __ __	_____

APPENDIX EP-243-1

DATA SHEET

I. Sample Source _____ Grab Sample Point _____
 Initial Sample Volume _____ Initial Contact Dose Rate _____
 Sample Date/Time _____/_____

- Processing Procedure: (X)
- (*) A. Sent offsite for analyses ()
 - (*)(**) B. Placed in temporary storage ()
 - C. Analyzed on-site ()

(*) If this method is used, sign and date this data sheet and terminate this procedure.

(**) The Chemistry Sampling and Analyses Group Leader shall determine the place of storage.

II.

Order of Analyses	Analysis	Procedure Number	Aliquot Size	*** Magnitude of Dilutions	**** Total Dilution Factor	***** Analysis Sample Volume	Acceptable Analysis Dose Rate
1	_____	_____	_____	_ _ _ _ _	_____	_____	_____
2	_____	_____	_____	_ _ _ _ _	_____	_____	_____
3	_____	_____	_____	_ _ _ _ _	_____	_____	_____
4	_____	_____	_____	_ _ _ _ _	_____	_____	_____

APPENDIX EP-243-1
DATA SHEET (CONT'D)

(***) Due to the complexity of the dilution and analysis process it is recommended that the same magnitude of dilution be used for all of the analyses. To calculate the magnitude of dilution use the following tables: (*****) Recommended sample volumes: GC - 100 micro liters

<u>Aliquot Size</u>	<u>1st dilution</u>	<u>2nd dilution</u>	<u>3rd dilution</u>	<u>4th dilution</u>
1 ml	14.4	207	2985	42998
.1 ml	144	2070	29850	429980

$$\text{Total Dilution Factor} = \frac{V_s}{14.4} \times \text{Magnitude of Dilution}$$

Vs = Volume of original sample (from the appropriate EP Sample Data Sheet)

Signature

Date / Time

J. J. Lutz 7/20/84

PHILADELPHIA ELECTRIC COMPANY
LIMERICK GENERATING STATION
EMERGENCY PLAN IMPLEMENTING PROCEDURE

EP-252 SEARCH AND RESCUE/FIRST AID

1.0 PURPOSE

The purpose of this procedure is to define the requirements and the actions of the Search and Rescue/First Aid Group.

2.0 RESPONSIBILITIES

- 2.1 The Personnel Safety Team Leader shall control the Search and Rescue/First Aid Group exposure and provide offsite medical support by performing the necessary steps in this procedure.
- 2.2 The Search and Rescue/First Aid Group Leader shall direct operations by performing the necessary steps in this procedure.
- 2.3 The Search and Rescue/First Aid Group members shall perform rescue operations by performing the necessary steps in this procedure.

3.0 APPENDICES

- 3.1 EP 252-1 Emergency Exposure Guidelines
- 3.2 EP 252-2 First Aid Equipment Locations
- 3.3 EP 252-3 Injured Personnel Report Form
- 3.4 EP-252-4 Medical Support Group Phone List

4.0 PREREQUISITES

None

CONTROLLED

VALID ONLY WHEN RED

5.0 SPECIAL EQUIPMENT

- 5.1 First Aid Kit

6.0 SYMPTOMS

- 6.1 Missing personnel or personnel with injury requiring first aid.

7.0 ACTION LEVEL

- 7.1 The Search and Rescue/First Aid Group is activated whenever personnel are known to be missing or in need of help.

8.0 PRECAUTIONS

- 8.1 Personnel shall participate in search and rescue operations on a voluntary basis.
- 8.2 Proper radiological controls shall be followed as much as practicable during search and rescue operations. Continuous coverage by Health Physics technician may be substituted for a Radiation Work Permit.
- 8.3 Planned radiation exposures should be limited to the administrative guide levels in Appendix EP-252-1 Emergency Exposure Guidelines.
- 8.4 Life-saving first aid treatment has priority over decontamination or treatment for radiation exposure.
- 8.5 Radiation exposure and group member contamination should be minimized as much as practical.
- 8.6 If gross external contamination is found, internal contamination should be suspected.
- 8.7 Any material removed from a contaminated person shall be recovered for potential use for isotopic analysis.
- 8.8 The Search and Rescue/First Aid Group Leader will maintain contact with the Personnel Safety Team Leader at the designated assembly area.

- 8.9 If first aid team is unable to move an injured person due to the nature of the injury, assistance of local ambulance personnel may be utilized.
- 8.10 If transportation of a contaminated injured person to an offsite medical facility is required, inform the (Interim) Emergency Director so that classification of the event per EP-101 may be performed.

9.0 PROCEDURE

9.1 ACTIONS

- 9.1.1 Personnel Safety Team Leader shall: 9.1.1.1 Select a qualified person at the OSC to be the Search and Rescue/First Aid Group Leader and to carry out Section 9.1.2 of this procedure.
- 9.1.1.2 Inform the (Interim) Emergency Director that search and rescue/first aid groups have been formed and of their intentions to enter the plant for search and rescue operations. (Attempt to locate missing person(s) by utilizing plant paging system just prior to actually dispatching the search and rescue group(s)).
- 9.1.1.3 Obtain exposure limits from the (Interim) Emergency Director. If later search and rescue operations are necessary, the (Interim) Emergency Director may adjust the radiation exposure limits accordingly. If waiting for (Interim) Emergency Director approval could endanger personnel, the search and rescue/first aid group leader may decide to remove injured person.
- 9.1.1.4 If offsite medical help is necessary, have the ambulance, hospital or physician contacted by using Appendix EP-252-4 Medical Support Groups Phone List. Always state the number of individuals involved, type of injury and if contamination is involved.
- 9.1.1.5 Notify security so that the offsite medical response group's access to the Restricted Area can be expedited, if necessary.

- 9.1.1.6 Recall the search and rescue groups when search and rescue operations are no longer necessary.
- 9.1.2 Search and Rescue/First Aid Group Leader shall:
 - 9.1.2.1 Select volunteers from available personnel to form search and rescue/first aid squads. Each squad shall consist of at least three members; two must be qualified in first aid and one must be a health physics technician.
 - 9.1.2.2 Ensure that each member has the necessary respiratory equipment, radsurvey equipment, anti-contamination clothing, and personal dosimetry. This material can be obtained from emergency survey kits at the OSC or from normal HP stocks.
 - 9.1.2.3 Discuss the situation with the Personnel Safety Team Leader. The following information should be obtained prior to performing search and rescue operations:
 - A. Number of missing persons.
 - B. Name of individuals.
 - C. Last known location of individuals.
 - D. The job being worked.
 - E. Any significant plant conditions that may affect the search and any special instructions.
 - 9.1.2.4 Ensure the group is equipped with a first aid kit, or can get one enroute. See attached Appendix EP-252-2 for listing of first aid equipment location in the plant.
 - 9.1.2.5 Coordinate search and rescue/first aid squads to minimize duplication of effort and unnecessary radiation exposure.
 - 9.1.2.6 Direct the groups to the last known location of the missing individual. If necessary, expand the search to adjacent areas. Ensure most expeditious routes available are taken to minimize team exposure.

- 9.1.2.7 Inform the Personnel Safety Team Leader of the actions of the group and whenever the group locates any missing personnel, and the identity of located personnel.
- 9.1.2.8 Determine the extent of the injury and direct administration of first aid.
- 9.1.2.9 Report to the Personnel Safety Team Leader the extent of the individual's injuries and recommend supplementary medical actions as necessary (i.e., hospitalization). Complete Appendix EP 252-3 (if possible) and attach to injured person prior to transporting in ambulance.
- 9.1.2.10 Report to the Personnel Safety Team Leader when the search and rescue/first aid group has finished its task.
- 9.1.3 Search and Rescue/First Aid Squad Members shall:
 - 9.1.3.1 Perform a radiation and contamination survey of the person and subsequently the area.
 - 9.1.3.2 Transport the injured person to a site first aid facility if practicable.
 - 9.1.3.3 Perform the following if the injured person is contaminated.
 - A. Wear necessary anti-contamination clothing if practicable.

IF THE INJURY IS SEVERE, IMMEDIATE MEDICAL TREATMENT IS OF THE HIGHEST PRIORITY AND RADIOLOGICAL CONTROLS ARE SECONDARY.
 - B. Administer appropriate first aid, being careful to limit the spread of contamination and limit personal exposure.
 - C. IF INJURY IS NOT SEVERE, DECONTAMINATION SHALL BE ATTEMPTED.
 - D. Prepare the person for transportation by covering the contaminated area with a protective wrap. Avoid excessive wrapping to prevent dehydration of the person.

IF THE INJURED PERSON IS GOING TO BE TRANSPORTED TO AN OFFSITE MEDICAL FACILITY, IT MAY NOT BE FEASIBLE TO BRING THE PERSON TO THE FIRST AID FACILITY, INSTEAD MOVE THE PERSON TO A SAFE PLACE WHICH IS EASILY ACCESSIBLE FOR THE TRANSFER TO A VEHICLE.

E. When transporting the victim to an offsite medical facility, a Health Physics Technician shall accompany the victim to assist the medical staff.

9.1.3.4 Recover any contaminated articles of clothing that may have been removed from the person for isotopic analysis.

9.2 Follow-Up

9.2.1 Search and rescue group members shall:

9.2.1.1 Report results of their actions to the Personnel Safety Team Leader.

9.2.1.2 Follow normal decontamination and disposal procedures when their tasks are complete.

9.2.2 Personnel Safety Team Leader shall:

9.2.2.1 Verify the victim's arrival at the medical facilities.

9.2.2.2 Inform the (Interim) Emergency Director of results of search and rescue efforts.

9.2.2.3 Have the (Interim) Emergency Director inform the Medical Director and Corporate Communications as to the identity and condition of the victim(s).

9.2.2.4 Have the Health Physics technician accompanying victim to the hospital, call the Personnel Safety Team Leader when informed by the hospital that his services are longer no needed. With the concurrence of the Personnel Safety Team Leader he may proceed to another assignment. Have the technician return dosimetry to site to be read.

9.2.2.5 Arrange for inventory and restocking of first aid kits, if necessary.

10.0 REFERENCES:

- 10.1 Limerick Generating Station Emergency Plan
- 10.2 NUREG 0654, Criteria for Preparation and
Rev.1 Evaluation of Radiological Emergency
Response Plans and Preparedness In
Support of Nuclear Power Plants.

APPENDIX EP 252-1
Emergency Exposure Guidelines

<u>Function</u>	<u>Projected Whole Body Dose</u>	<u>Thyroid Dose</u>	<u>Authorized By</u>
1. Life Saving and Reduction of Injury	75 rem*	375 rem	(Interim) Emergency** Director
2. Operation of Equipment to Mitigate an Emergency	25 rem*	125 rem	(Interim) Emergency** Director
3. Protection of Health and Safety of the Public	5 rem	25 rem	(Interim) Emergency** Director
4. Other Emergency Activities	10 CFR 20 limits	10 CFR 20 limits	(Interim) Emergency Director
5. Re-entry/Recovery Activities	Station Administrative Guidelines	Station Administrative Guidelines	N/A

* Reference: EPA-520/1-75-001 Table 2.1

** Such exposure shall be on a voluntary basis

APPENDIX EP-214-2
FIRST-AID EQUIPMENT LOCATIONS

	<u>STRETCHERS</u>	<u>FIRST AID SETS</u>	<u>BLANKETS</u>
Unit 1 RX Encl. Elevator Stairwells			
Elev. 177'	X	X	X
Elev. 201'	X	X	X
Elev. 217'	X	X	X
Elev. 239'	X	X	X
Elev. 253'	X	X	X
Elev. 283'	X	X	X
Elev. 313'	X	X	X
Elev. 351'	X	X	X
Elev. 352'	X	X	X
Unit 2 RX Encl. Elevator Stairwells			
Elev. 177'	X	X	X
Elev. 201'	X	X	X
Elev. 217'	X	X	X
Elev. 239'	X	X	X
Elev. 253'	X	X	X
Elev. 283'	X	X	X
Elev. 313'	X	X	X
Elev. 331'	X	X	X
Elev. 352'			
Turbine Encl. East & West Stairwells			
Elev. 200'		X	
Elev. 217'		X	
Elev. 239'		X	
Elev. 269'		X	
Turbine Encl. Equipment Hatch			
Elev. 217'		X	X

	<u>STRETCHERS</u>	FIRST AID <u>KITS</u>	<u>BLANKETS</u>
--	-------------------	--------------------------	-----------------

Control Enclosure Elevator Stairwells

Elev. 180'	X	X	X
Elev. 200'	X	X	X
Elev. 217'	X	X	X
Elev. 239'	X	X	X
Elev. 254'	X	X	X
Elev. 269'	X	X	X
Elev. 289'	X	X	X
Elev. 304'	X	X	X
Elev. 332'	X	X	X

Radwaste Encl. North Stairwell

Elev. 162'		X	X
Elev. 191'		X	X
Elev. 217'		X	X
Elev. 237'		X	X
Elev. 257'		X	X

Circ. Water Pump House

X

220 Switchyard Encl.

X

500 Switchyard Encl.

X

NOTE: 1/2 Mile Rays (Emergency Flashlights) Are Located Just Outside Door To Unit 2 Side of Main Control Room In Cabinet.

APPENDIX EP 252-3
INJURED PERSONNEL REPORT FORM
(PREPARE IN DUPLICATE)

Injured Person's Name _____

Age _____

Badge No. Or
Social Security No. _____

Male _____ Female _____

Type and Location of Injury _____

Radioactive Contamination _____ Yes _____ No _____ Level

Location _____

Radiation Exposure Estimate _____

Where Did Injury Occur _____

Prepared by First Aid Group Leader _____
SIGNATURE

Group Members _____

If practicable forward original, with the person, to the site
first aid facility or hospital as appropriate.

APPENDIX EP 252-4
MEDICAL SUPPORT GROUP PHONE LIST

Local Physicians

[REDACTED]
 [REDACTED]
 [REDACTED]
 [REDACTED]
 [REDACTED]
 [REDACTED]
 [REDACTED]
 [REDACTED]
 [REDACTED]
 [REDACTED]
 [REDACTED]
 [REDACTED]

<u>Office</u>	<u>Home</u>
[REDACTED]	[REDACTED]
[REDACTED]	[REDACTED]
(Contaminated or otherwise)	
[REDACTED]	
[REDACTED]	
[REDACTED]	
[REDACTED]	
[REDACTED]	
[REDACTED]	
[REDACTED]	
[REDACTED]	
[REDACTED]	
[REDACTED]	
[REDACTED]	
[REDACTED]	
<u>Preferred</u>	<u>Alternate</u>
[REDACTED]	[REDACTED]
[REDACTED]	[REDACTED]
[REDACTED]	[REDACTED]
[REDACTED]	[REDACTED]

PROPRIETARY
 Serious Contamination/Exposure*
 multiple contaminated personnel

*Serious Contamination/Exposure is:
 Whole Body Exposure greater than 25 REM or skin exposure greater than 150 REM or extremity exposure greater than 375 REM or contamination causing body contacted reading of greater than 1 MR/HR or suspected or actual inhalation or ingestion of measurable quantities of radioactive material.

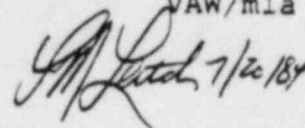
Handwritten signature and date: J. L. Litch, 7/20/84

PHILADELPHIA ELECTRIC COMPANY
LIMERICK GENERATING STATION
EMERGENCY PLAN IMPLEMENTING PROCEDURE

PROPRIETARY

EP-292 CHEMISTRY SAMPLING AND ANALYSIS TEAM PHONE LIST

1.0 PURPOSE

The purpose of this procedure is to provide guidelines and information for notification of the Chemistry Sampling and Analysis Team.

2.0 RESPONSIBILITIES

2.1 The Chemistry Sampling and Analysis Team Leader shall be responsible to call team members.

3.0 APPENDICES

None

4.0 PREREQUISITES

None

5.0 SPECIAL EQUIPMENT

None

6.0 SYMPTOMS

None

7.0 ACTION LEVEL

This procedure can be used when the Chemistry Sampling and Analysis Team is activated or when additional personnel are needed.

8.0 PRECAUTIONS

None

9.0 PROCEDURE

9.1 ACTIONS

9.1.1 The Chemistry Sampling and Analysis Team Leader shall call in people from the following list until appropriate positions are filled.

9.1.1.1 [REDACTED]

	<u>Home</u>	<u>Work</u>
[REDACTED]	[REDACTED]	[REDACTED]

9.1.1.2 [REDACTED]

	<u>Home</u>	<u>Work</u>
[REDACTED]	[REDACTED]	[REDACTED]

9.1.1.3 [REDACTED]

	<u>Home</u>	<u>Work</u>
[REDACTED]	[REDACTED]	[REDACTED]

PROPRIETARY

Home

Work

[REDACTED]

[REDACTED]

[REDACTED]

PROBATION

REFERENCES

None

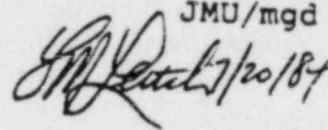
Handwritten signature and date: JMU/mgd 7/20/87

PHILADELPHIA ELECTRIC COMPANY
LIMERICK GENERATING STATION
EMERGENCY PLAN IMPLEMENTING PROCEDURE

EP-330 EMERGENCY RESPONSE FACILITY HABITABILITY

1.0 PURPOSE

The purpose of this procedure is to provide habitability guidelines for the Technical Support Center, Operations Support Center, Control Room, Chemistry Lab Area, and Maintenance Staging Area.

2.0 RESPONSIBILITIES

- 2.1 The (Interim) Personnel Safety Team Leader is responsible for determining the radiological habitability of the Emergency Response Facilities.
- 2.2 The (Interim) Chemistry Sampling and Analysis Group Leader is responsible for determining the habitability of the Emergency Response Facility if toxic substances are suspected in the atmosphere of the facility.
- 2.3 The facility director is responsible for determining if an evacuation of the facility is warranted based on the information provided by the HP and/or Chemistry Technician.

3.0 APPENDICES

- 3.1 EP-330-1 Emergency Response Facility Radiological Habitability Guidelines
- 3.2 EP-330-2 Determination of Toxic Gas Concentrations

4.0 PREREQUISITES

- 4.1 An emergency has been declared in accordance with EP-101, Classification of Emergencies.

CONTROLLED

COPY

VALID ONLY WHEN RED

5.0 SPECIAL EQUIPMENT

- 5.1 Toxic Gas Detection Equipment
- 5.2 Oxygen Monitor
- 5.3 Continuous Air Monitors
- 5.4 Radiation Survey Meter

6.0 SYMPTOMS

None

7.0 ACTION LEVEL

- 7.1 Known or suspected chemical release as indicated by:
 - 7.1.1 Control Room toxic gas detection system or chlorine gas detection system alarming.
 - 7.1.2 Fire in the plant.
 - 7.1.3 Visual observation or detection by odor in the area of the facility.
 - 7.1.4 Train derailment on or near the site.
 - 7.1.5 Report from Shift Supervision of toxic gas or chlorine release from nearby offsite facility.
- 7.2 Upon alert or alarm of ERF continuous air monitor.
- 7.3 Alert or alarm of an ERF area radiation monitor.

8.0 PRECAUTIONS

None

9.0

PROCEDURE

9.1

ACTIONS

- 9.1.1 The (Interim) Emergency Director shall:
- 9.1.1.1 Direct the (Interim) Personnel Safety Team Leader to perform habitability surveys of the Emergency Response Facilities and to report the results of the surveys to the appropriate Facility Director.
- 9.1.2 The (Interim) Personnel Safety Team Leader shall:
- 9.1.2.1 Direct the Plant Survey Group Leader to perform a radiological habitability evaluation of the Emergency Response Facilities (as required) and to report results of the surveys to the appropriate Facility Director.
- 9.1.3 The Plant Survey Group Leader shall:
- 9.1.3.1 Instruct a Health Physics Technician to
- A. Report to the appropriate Emergency Response Facility and perform a radiological habitability evaluation. Perform a general area dose rate and draw an air sample to determine ¹³¹I concentrations.
 - B. Compare the evaluation with Appendix 330-1 and inform the appropriate Facility Director that,
 - (1) Present radiological conditions within the guidelines of Appendix EP-330-1.
 - (2) Present radiological conditions that exceed the guidelines in Appendix EP-330-1 and to what extent the guidelines are exceeded.
 - D. Report the results back to the Survey Group Leader or (Interim) Personnel Safety Team Leader.
- 9.1.4 Health Physics Technician shall:
- 9.1.4.1 For the TSC, OSC, Chemistry Lab and Maintenance Office perform the following:

- A. Start a continuous air monitor, if not already operating, and document baseline readings or perform an airborne survey and analysis in accordance with HP-213 and HP-214.
- B. If continuous air monitor baseline readings or air sample results exceed the values in Appendix EP-330-1 or the equipment is not operable, notify the Plant Survey Group Leader or (Interim) Personnel Safety Team Leader.
- C. Perform a general area survey.
- D. Set up a frisker, if there is not one present, at the entrance to the emergency response facility.

9.1.4.2 For the Control Room, perform the following:

- A. Determine the status of Control Room ventilation (e.g., isolated).
- B. Perform a general area radiation survey.
- C. Set up a frisker, if there is not one, at the Control Room entrance.

9.1.4.3 Report the results of the habitability check to the respective emergency response facility personnel indicated below and Plant Survey Group Leader.

A. <u>Emergency Response Facility</u>	<u>Emergency Response Facility Personnel</u>
Technical Support Center	Emergency Director
Operations Support Center	OSC Coordinator
Control Room	Shift Supervision
Chemistry Lab Area	Chemistry Sampling And Analysis Group Leader
Maintenance Office	Senior Person Present or Fire and Damage Team Leader

- 9.1.5 Chemistry Sampling and Analysis Group Leader shall:
- 9.1.5.1 When required, instruct a chemistry technician to:
- A. Perform a chemistry habitability survey of the appropriate facility using Appendix EP-330-2, Determination of Toxic Gas Concentrations
 - B. Compare the survey results with Appendix EP-330-2 and inform the appropriate facility director that:
 - (1) Present atmospheric conditions do not exceed the guidelines in Appendix EP-330-2
 - (2) Present atmospheric conditions do exceed the guidelines of Appendix EP-330-2 and to what extent the guidelines are exceeded
 - C. Report the results back to the Chemistry Sampling and Analysis Group Leader.
- 9.1.5.2 Report the results to the Chemistry Sampling and Analysis Team Leader.
- 9.1.6 Chemistry Technician shall:
- 9.1.6.1 Report to the appropriate Emergency Response Facility and perform the following:
- USE OF RESPIRATORY PROTECTION EQUIPMENT SHOULD BE CONSIDERED (SCBA) FOR ENTRY INTO A FACILITY WITH SUSPECTED TOXIC SUBSTANCES IN THE ATMOSPHERE.
- A. Perform a check of the Emergency Response Facility for toxic gas concentrations in accordance with Appendix EP-330-2.
 - B. Use Appendix EP-330-2 to determine if the measured toxic gas concentrations levels are acceptable.
- 9.1.6.2 Report the results of the survey to the respective emergency response personnel and the Chemistry Sampling and Analysis Group Leader.

<u>Emergency Response Facility</u>	<u>Emergency Response Facility Personnel</u>
Technical Support Center	Emergency Director
Operations Support Center	OSC Coordinator
Control Room	Shift Supervision
Chemistry Lab Area	Chemistry Sampling And Analysis Group Leader
Maintenance Office	Senior Person Present or Fire and Damage Team Leader

9.2 FOLLOW-UP

9.2.1 The Facility Director shall:

9.2.1.1 Based on the information provided by the Health Physics Technician or Chemistry Technician determine if the facility should be evacuated or if protective devices are needed.

THIS DECISION SHOULD BE BASED ON THE TYPE OF HAZARD, THE EXPECTED DURATION OF THE HAZARD OR FACILITY OCCUPATION AND IF A SUITABLE ALTERNATE LOCATION IS AVAILABLE. THIS DECISION SHOULD BE DISCUSSED WITH THE (INTERIM) EMERGENCY DIRECTOR, IF APPLICABLE AND IF TIME PERMITS.

9.2.2 Plant Survey Group Leader or (Interim) Personnel Safety Team Leader shall:

9.2.2.1 Establish the frequency and type of follow-up radiological monitoring for the Emergency Response Facilities.

9.2.3 Chemistry Sampling and Analysis Group Leader shall:

9.2.3.1 Establish the frequency and type of follow-up chemical monitoring for the Emergency Response Facilities.

9.2.4 The Health Physics Technician and Chemistry Technician shall:

9.2.4.1 File the survey results and report to their appropriate Group Leader for re-assignment.

10.0 REFERENCES

- 10.1 NUREG-0696 - Criteria for Preparation and Evaluation of
Rev. 1 Radiological Emergency Response Plans
and Preparedness in Support of Nuclear
Power Plants.
- 10.2 FSAR 1.13.2 Item II.B.2 - Plant Shielding
- 10.3 FSAR Table 2.2-6 - Potentially Hazardous Chemicals
Requiring Monitoring
- 10.4 29 CFR 1910.1000
- 10.5 29 CFR 1910.1017
- 10.6 HP-210 Radiation Survey Techniques
- 10.7 HP-212 Airborne Contamination Monitoring--CAMS
- 10.8 HP-213 Airborne Contamination Sampling Techniques
- 10.9 HP-214 Air Sample Analysis and Evaluation

APPENDIX EP-330-1

EMERGENCY RESPONSE FACILITY RADIOLOGICAL HABITABILITY GUIDELINES

Whole Body Dose Rate	25 mR/hr
Airborne concentration	0.25 MPC

NOTE

THESE VALUES CORRESPOND TO ADMINISTRATIVE GUIDELINES WHICH WILL BE RETAINED DURING EMERGENCY CONDITIONS, OF 300 mR/DAY AND 20 MPC-HRS/WEEK. ASSUME 12 HOUR OCCUPANCY TIMES PER PERSON PER DAY. IF THE RADIOLOGICAL CONDITIONS EXCEED THESE VALUES, NOTIFY THE PERSONNEL SAFETY TEAM LEADER FOR ACTIONS TO BE TAKEN.

APPENDIX EP-330-2

DETERMINATION OF TOXIC GAS CONCENTRATIONS

Obtain the necessary equipment and check the pump performance performing the following steps:

NOTE

STEPS A, B AND C ARE TO BE DONE AWAY FROM THE AREA IN QUESTION

Checking Pump Performance

- A. Visually check rubber inlet flange for cracks or tears. Replace if damaged. Tighten inlet clamping nut.
- B. Valve Leak Check
 1. Insert a fresh sealed detector tube into pump. Misalign red dots on pump and handle. Pull several fairly rapid continuous full pump strokes.
 2. Pull handle out 6 mm (1/4 inch) and hold in this position for 1 or 2 seconds.
 3. Release handle.
 4. If handle returns to within 1.5 mm (1/16 inch) or less of fully closed position, continue to step 5.
 5. If handle does not return to within 1.5 mm (1/16 inch) of fully closed position (or less), consult Chemistry Supervision.
- C. Field Volume Check
 1. Insert a fresh sealed detector tube into pump.
 2. Align red dots on pump body and handle.
 3. Pull handle firmly and at a moderate speed until handle locks into position. Wait 1 minute.
 4. Unlock handle by turning it and guide it back. TO PROTECT PUMP STOPPER from breakage, do not release the handle and allow it to spring back when conducting a leak test. Make sure you hold your hand onto the handle and guide it back.
 5. Pump handle should return to within 6 mm (1/4 inch) or less of the fully closed position.
 6. If pump handle does not close to within 6 mm (1/4 inch) or less, consult Chemistry Supervision.

APPENDIX EP-330-2 (CON'T)

NOTE

STEP D IS TO BE DONE AT THE AREA IN QUESTION

D. Sampling & Measurement Procedure

1. Break tips off a fresh detector tube by bending each tube end in the tube tip breaker of the pump.
2. Insert tube securely into pump inlet with arrow on tube pointing toward pump.
3. For twin tubes, connect "c" marked ends with rubber tubing after breaking each end. Insert analyzer tube into pump with arrows on tubes pointing toward pump.
4. Make certain pump handle is all the way in. Align guide marks on pump body and handle.
5. Pull handle out to desired stroke volume. Handle can be locked on either 1/2 pump stroke (50 ml) or 1 pump stroke (100 ml).
6. Read concentration at the interface of stained-to-unstained reagent when staining stops. Unlock handle by making 1/4 turn and return it to starting position.
7. In case more pump strokes are indicated in the instruction sheet included in each box of tubes, take additional sample by repeating pump strokes without removing tube.
8. Calculate the result by dividing the reading by the number of pump strokes and record in the Data Sheet.
9. Determine if habitability is within limits remembering there is a percent error on the results. (See Data Sheet).
10. Complete the Data Sheet and forward to the Group Leader.

APPENDIX EP-330-2 (CONT'D)

LOCATION: _____

DATE: _____

TIME: _____

Perform (check)	Gas (tubes)	Limit (ppm)	Reading (ppm)	No. of pump strokes(n)	Result (ppm)	Habitability Yes/No
	Chlorine*	<.1.0				
	Ammonia	<50				
	Ethylene Oxide	<50				
	Formaldehyde	<3				
	Vinyl Chloride	<1.0				
	Phosyene	<0.1				

Allowable exposure to Air Contaminants

Maximum exposure allowed by OSHA in an 8 hour work shift of a 40 hour work week (Time weighted Averages).

*NIOSH Certified Tubes, \pm 25% Accuracy

Non-NIOSH Certified Tubes, \pm 50% Accuracy

NAME: _____

