

NUREG/CR-4112
US 75-2
Vol. 2

Investigation of Cable and Cable System Fire Test Parameters

Task B: Firestop Test Method

Underwriters Laboratories Inc.

Prepared for
U.S. Nuclear Regulatory
Commission

8502130568 850131
PDR NUREG
CR-4112 R PDR

NOTICE

This report was prepared as an account of work sponsored by an agency of the United States Government. Neither the United States Government nor any agency thereof, or any of their employees, makes any warranty, expressed or implied, or assumes any legal liability of responsibility for any third party's use, or the results of such use, of any information, apparatus, product or process disclosed in this report, or represents that its use by such third party would not infringe privately owned rights.

NOTICE

Availability of Reference Materials Cited in NRC Publications

Most documents cited in NRC publications will be available from one of the following sources:

1. The NRC Public Document Room, 1717 H Street, N.W.
Washington, DC 20555
2. The NRC/GPO Sales Program, U.S. Nuclear Regulatory Commission,
Washington, DC 20555
3. The National Technical Information Service, Springfield, VA 22161

Although the listing that follows represents the majority of documents cited in NRC publications, it is not intended to be exhaustive.

Referenced documents available for inspection and copying for a fee from the NRC Public Document Room include NRC correspondence and internal NRC memoranda; NRC Office of Inspection and Enforcement bulletins, circulars, information notices, inspection and investigation notices; Licensee Event Reports; vendor reports and correspondence; Commission papers; and applicant and licensee documents and correspondence.

The following documents in the NUREG series are available for purchase from the NRC/GPO Sales Program: formal NRC staff and contractor reports, NRC-sponsored conference proceedings, and NRC booklets and brochures. Also available are Regulatory Guides, NRC regulations in the *Code of Federal Regulations*, and *Nuclear Regulatory Commission Issuances*.

Documents available from the National Technical Information Service include NUREG series reports and technical reports prepared by other federal agencies and reports prepared by the Atomic Energy Commission, forerunner agency to the Nuclear Regulatory Commission.

Documents available from public and special technical libraries include all open literature items, such as books, journal and periodical articles, and transactions. *Federal Register* notices, federal and state legislation, and congressional reports can usually be obtained from these libraries.

Documents such as theses, dissertations, foreign reports and translations, and non-NRC conference proceedings are available for purchase from the organization sponsoring the publication cited.

Single copies of NRC draft reports are available free, to the extent of supply, upon written request to the Division of Technical Information and Document Control, U.S. Nuclear Regulatory Commission, Washington, DC 20555.

Copies of industry codes and standards used in a substantive manner in the NRC regulatory process are maintained at the NRC Library, 7920 Norfolk Avenue, Bethesda, Maryland, and are available there for reference use by the public. Codes and standards are usually copyrighted and may be purchased from the originating organization or, if they are American National Standards, from the American National Standards Institute, 1430 Broadway, New York, NY 10018.

NUREG/CR-4112
US 75-2
Vol. 2
RP

Investigation of Cable and Cable System Fire Test Parameters

Task B: Firestop Test Method

Manuscript Completed: December 1984
Date Published: January 1985

Underwriters Laboratories Inc.
333 Pfingsten Road
Northbrook, IL 60062

Prepared for
Division of Engineering Technology
Office of Nuclear Regulatory Research
U.S. Nuclear Regulatory Commission
Washington, D.C. 20555
NRC FIN B6197

NOTICE

This report was prepared as an account of work sponsored by an agency of the United States Government. Neither the United States Government nor Underwriters Laboratories Inc. nor any of their employees nor any of their contractors, subcontractors, or their employees make any warranty, express or implied, or assume any legal liability or responsibility for damages arising out of or in connection with the interpretation, application or use of or inability to use any information, apparatus, product, or processes disclosed, or represents that its use would not infringe on privately owned rights. This report may not be used in any way to infer or to indicate acceptability for Listing, Classification, Recognition or Certificate Service by Underwriters Laboratories Inc. for any product or system.

ABSTRACT

An experimental investigation was conducted to provide data concerning the effects that changes in pressure differential, fire exposure and sample construction have on firestop performance when exposed to a standard fire test. Fifty-one fire test experiments were conducted using pressure differentials between -12 to +120 Pa, different sample constructions and two fire exposure conditions. Findings were that small changes in pressure differential did not have a significant effect on firestop materials that did not have cracks or through openings to allow passage of gases during fire exposure. If the materials allowed passage for gases through cracks or holes, such as those left open after pulling a cable, changing the pressure differential affected the firestop performance. Also, it was demonstrated that changing the size of the opening; size, location and type of the penetrating items installed through the opening; and severity of fire exposure affected the performance of the firestop.

TABLE OF CONTENTS

Abstractiii
List of Figures.vii
List of Tablesix
Acknowledgementsxi

1. Introduction.1
 1.1 Background1
 1.2 Objectives, Scope and Plan2

2. Experimental Procedure.5
 2.1 Samples.5
 2.2 Firestop Sample Construction6
 2.3 Equipment.6
 2.4 Instrumentation.7
 2.5 Method8

3. Results and Discussion.9
 3.1 General.9
 3.2 Pressure Differential Experiments.9
 3.3 Fire Exposure Experiments.11
 3.4 Sample Construction Experiments.12

4. Findings.15
 4.1 Differential Pressure.15
 4.2 Fire Exposure.15
 4.3 Sample Construction.16

5. References.18

LIST OF FIGURES

<u>Figure</u>	<u>Description</u>	<u>Page</u>
1	Floor Slabs	42
2	Small-Scale Furnace	43
3	Enclosure	44
4	Pressure Probe Locations	45
5	Furnace Temperature Curves	46
6	Unexposed Surface Temperatures; Exps. 1, 3, 5, 7 and 9	47
7	Unexposed Surface Temperatures; Exps. 2, 4, 6, 8 and 10	48
8	Unexposed Surface Temperatures; Exps. 23 and 24	49
9	Unexposed Surface Temperatures; Exps 23 and 24	50
10	Unexposed Surface Temperatures; Exps. 23 and 25	51
11	Unexposed Surface Temperatures; Exps. 23 and 25	52
12	Unexposed Surface Temperatures; Exps. 26, and 49	53
13	Unexposed Surface Temperatures; Exps. 35 39 and 41	54
14	Unexposed Surface Temperatures; Exps 38, 40 and 42	55
15	Unexposed Surface Temperatures; Exps. 35 and 37	56
16	Unexposed Surface Temperatures; Exps. 36 and 38	57
17	Conductor Temperatures; Exps. 31, 32 33, 34 and 39	58
18	Unexposed Surface Temperatures; Exps. 43 and 44	59
19	Unexposed Surface Temperatures; Exps. 45 and 48	60
20	Unexposed Surface Temperatures; Exps. 49 and 50	61

LIST OF TABLES

<u>Table</u>	<u>Description</u>	<u>Page</u>
1	Pressure Differential Experiments	19
2	Pressure Differential Experiments - Cracks and Holes	20
3	Fire Exposure Experiments	21
4	Sample Experiments - Conductor & Size	22
5	Sample Experiments - Cable Construction	23
6	Sample Experiments - Conduit or Pipe Type and Size	24
7	Sample Experiments - Cable Loading	25
8	Sample Experiments - Size	26
9	Cable Constructions	27
10	Conduit and Pipes	28
11	Pressure Differential Samples	29
12	Pressure Differential Samples - Cracks and Holes	30
13	Fire Exposure Samples	31
14	Samples Constructions - Conductor Type and Size	32
15	Sample Constructions - Conduit or Pipe	33
16	Sample Constructions - Cable Loading	34
17	Sample Constructions - Opening Sizes	35
18	Slab Humidities	36
19	Thermocouple Locations	37
20	Pressure Experiments - Flame Occurrence Times	38
21	Flame Occurrence Times and Pressures - Exp. 51	39
22	Time to Flaming - Exps. 24, 25 and 26	40
23	Time to Flaming	41

ACKNOWLEDGEMENTS

The US Nuclear Regulatory Commission through its office of Nuclear Regulatory Research maintains an ongoing fire protection research program. The program is intended to obtain data in support of current regulatory guides and standards for fire protection and control in light water reactor power plants and to establish an improved technical basis for modifying these guides and standards where appropriate. The investigation described in this Report is one task of an element of this program.

This investigation was conducted at Underwriters Laboratories' facility in Northbrook, IL. The authors wish to thank the technical and engineering staff members, especially Tom Plens, Chris Johnson, Stan Lesiak and Sandi Hansen, for their effort in conducting the experiments and preparing the data.

Respectfully submitted:

Underwriters Laboratories Inc.

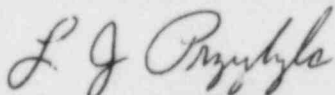

L. J. PRZYBYLA
Engineering Group Leader
Fire Protection Department

Reviewed by:

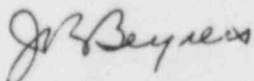

J. R. BEYREIS
Managing Engineer
Fire Protection Department

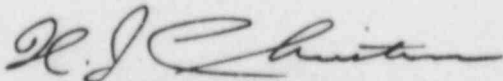

W. J. CHRISTIAN
Manager
Research and Technology Development

1. INTRODUCTION

1.1 BACKGROUND:

The US Nuclear Regulatory Commission (NRC), through its Office of Nuclear Regulatory Research (RES), initiated fire protection research in 1975¹ with an investigation of a limited cable tray separation verification program to obtain data for evaluating some guidelines of Regulatory Guide 1.75². After the Browns Ferry fire and following recommendations made by the Special Review Group, RES established an expanded fire protection research program to augment the cable separation studies and to investigate other fire protection concerns.

One fire protection concern is the qualification of penetration firestops. Materials and devices are installed to fill openings in fire resistive floors and walls that are provided for the passage of items, such as cables and pipes. These materials and devices are installed in the openings to retard the spread of fire between compartments. A firestop is the specific construction consisting of the materials that fill the opening together with the penetrating items such as cables, cable trays and pipes.

Some of the NRC guidelines for qualification testing of firestops are contained in App. A to Branch Technical Position APCS 9.5-1.⁵ These guidelines recommend that firestops should give protection at least equivalent to that of the fire resistive floor or wall and that firestops at least comply with the requirements of ASTM E119⁶ which is the standard used to evaluate fire resistive assemblies.

Within the past few years, test methods have been developed specifically for investigating firestops. One test that has been used to evaluate the performance of firestops installed in nuclear power plants is described in IEEE 634⁷. This standard describes the test procedure and criteria for acceptance. The test procedure consists of subjecting the sample firestop to a fire exposure in accordance with ASTM E119. Immediately after fire exposure, the sample is subjected to a water spray (hose stream test). The firestop is acceptable if it withstands the fire test without passage of flame or gases hot enough to ignite cable on the nonfire side, and if it limits the temperature on the nonfire side to less than 700°F. Also, the sample must withstand the hose stream test without developing an opening which allows the passage of a water stream. This test method provides a means of determining the ability of a particular firestop design to resist the passage of flame when exposed to a "standard" fire. Accordingly, fire stop designs can be rated according to their duration of fire exposure as expressed in hours or fractions of hours. However, the ratings are not absolute values. It is intended that the test method obtain

results that provide a degree of correlation to the fire performance of firestops in a nuclear power plant during a fire. The test method was not intended to obtain the performance of firestops under all possible fire conditions that could be encountered.

However, there has been some concern about the effects on performance of the test specimen when certain test parameters are changed. These are 1) the pressure differential (the pressure at one side of the firestop with respect to the other side), 2) firestop construction and 3) fire exposure.

Pressure Differentials - Pressure differentials exist in the plant under normal operation. These pressure differentials are dynamic, changing with the ventilation system operation. Also, they may change during a fire. IEEE 634 discusses this problem and recommends that it be studied as a future task, but does not require that one specific differential be applied during the test.

Firestop Construction - Sample selection for testing is to be representative of the firestop installed in the plant. To facilitate selection, suggested guidelines are provided in IEEE 634 for size of opening and types and sizes of cables, but data substantiating the selection are not referenced. The effects of varying the sample construction could be significant, and a method to determine quantitatively the effect of changes in sample construction would be advantageous.

Fire Exposure - The fire exposure for the sample is the standard time-temperature curve described in ASTM E119. However, the heat released during a real fire in a plant may have a significantly different temperature-time relationship. Data on the effects of different temperature-time exposures could be useful.

1.2 OBJECTIVES, SCOPE AND PLAN:

The objective of this investigation was to develop data to be used in evaluating the effects of changes in 1) pressure differential, 2) fire exposure and 3) firestop construction.

In connection with this overall objective, specific objectives were

1. To develop data on the following when the pressure differential is changed:
 - A. Unexposed surface temperatures

- F. Time at which flaming occurs on the unexposed side
 - C. Formation of cracks in the firestop material
 - D. Structural failure of the firestop materials
2. To explore changes in pressure differential regarding flaming on the unexposed side when there are holes in the firestop material or concrete floor slab.
 3. To develop data on the following when the fire exposure is changed:
 - A. The time when flaming occurs on the unexposed side
 - B. Unexposed side temperature.
 4. To explore the affect that changes in firestop construction parameters have on the following:
 - A. The surrounding material temperature on the unexposed side when the cable conductor size is changed
 - B. The temperature of the surrounding firestop material when aluminum conductors are used instead of copper
 - C. The conductor temperatures and the observed performance when cables are used with different jacket/insulation materials
 - D. The interface temperature between the pipe and the unexposed surface of the firestop material when the pipe size is changed
 - E. The interface temperature between the conduit and the unexposed surface of the firestop material when the conduit size and type is changed
 - F. The unexposed surface of the firestop material near the cable group when the number of cables in a group is changed
 - G. The cracking and deflection of the firestop material when different size openings are used

The investigation consisted of fifty-one fire test experiments that were conducted on firestops installed in concrete floor slabs. Each test was conducted in general accordance with IEF 634 with the data obtained being the physical performance (cracks and flaming) and the temperature measurements at various locations within and on the unexposed surface of the firestop material and on the penetrating items.

The plan of the investigation consisted of the following:

1. Experiments
2. Comparative Analysis
3. Findings

The experiments were organized into groups to simplify data comparisons and are identified in Tables 1-8. To consolidate experimentation, some fire tests consisted of two firestop samples, each considered a separate experiment.

2. EXPERIMENTAL PROCEDURE

2.1 SAMPLES:

The firestops that were tested were designed and installed to obtain data on the effects that changes in certain test parameters have on performance. They were not intended to obtain a 3 h or any other specific rating.

Floor Slabs

The normal weight concrete slabs, except for Experiment 51, were 36 by 36 by 6 in. thick (0.915 by 0.915 by 0.15 m thick). The slabs were cast with either 2 in. (0.05 m), 6 in. (0.15 m), 9 in. (0.229 m) or 12 in. (0.305 m) diameter holes or with a 12 in. (0.305 m) square opening, as shown in Fig. 1. The mix was one part Type I Portland cement, 2.13 parts sand and 3.45 parts gravel by bulk volume and mixed with about 7 gal (0.027 m³) of water per bag of cement. The concrete strength, as determined from standard 6 in. (0.15 m) by 12 in. (0.305 m) cylinders that were aged 28 days at room temperature, ranged from 3290 to 3430 psi (22.68 to 23.65 MPa) and averaged 3350 psi (23.10 MPa). The 28 day unit weight was 147 lb/ft³ (2.35 Mg/m³).

The slab for Experiment 51 was 36 by 36 by 2 in. thick (0.915 by 0.915 by 0.051 m thick). Four holes, 6 in. (152 mm), 3 in. (76 mm), 0.75 in. (19 mm) and 0.50 in. (12 mm) in diameter were drilled in the slab located as shown in Fig. 1.

Penetrating Items

Each penetrating item was cut from the nominal lengths supplied by the manufacturer into 54 in. (1.37 m) long pieces.

Cables - Eight different constructions were used as described in Table 9.

Conduits - Steel and aluminum rigid conduits were used in 1 and 3 in. trade sizes (Table 10).

Pipes - Schedule 40 steel pipes were used in 1 and 3 in. trade sizes (Table 10).

Cable Tray - The open ladder type tray was made from 0.065 in. (0.65 mm) thick galvanized steel. The side rails were 3.375 in. (86 mm) deep with 0.75 in. (19 mm) flanges. The rungs were ventilating type, 4 in. (102 mm) wide and spaced 9 in. (0.229 m). The loading depth was 3.0 in. (75 mm).

Firestop Materials

The materials used were proprietary products. Investigation of other similar firestop materials was not conducted.

Silicone Foam - A two component, room temperature vulcanized foam was used. Part A and Part B were hand mixed in accordance with the manufacturer's installation instructions. The free rise densities were between 27.5-32.0 lb/ft³ (0.44-0.51 Mg/m³).

Silicone Elastomer - A two component, room temperature vulcanized elastomer was used. Part A and Part B were hand mixed in accordance with the manufacturer's installation instructions. The free rise densities were between 86.0-89.0 lb/ft³ (1.38-1.43 Mg/m³).

Device - The device consisted of three components. Steel pressure discs, 0.365 in. (9 mm) thick, were located one at the top and one at the bottom. Between the steel discs were two layers of 1 in. (25 mm) thick intumescent material with a single layer of 1 in. (25 mm) thick neoprene grommet at the center. The devices were installed by tightening screws until the grommet material squeezed around the cables and inside of the opening. When cables were used, holes for the cables were drilled to proper size and location at the factory.

2.2 FIRESTOP SAMPLE CONSTRUCTION:

Typically, the test samples were constructed by installing penetrating items through the hole in the slab and then installing the firestop material or device. The penetrating items were installed so that 12 in. (0.305 m) was below the slab and 36 in. (0.915 m) was above the slab. Cables were fastened to a rack on the unexposed side for support. The firestop materials were prepared and installed into the hole in accordance with the instructions from the manufacturer. The type of slab, type of firestop material and the number and type of penetrating items used for each experiment are described in Tables 11-17.

2.3 EQUIPMENT:

Furnaces

The small-scale floor furnace of ULI (Fig. 2) was used to provide the fire exposure condition. Natural gas was used for fuel. The gas entered the furnace through multi-jet burners and together with castable refractory baffles produced luminous and well distributed flames within the furnace. The furnace chamber was exhausted with an induced-draft fan.

The furnace was located within a test building which was heated, if needed, to increase the initial temperature of the samples and the surrounding air to at least 60°F (16°C).

Enclosure

In some experiments, to obtain the desired pressure differential, an enclosure (Fig. 3) was placed on the unexposed side of the sample with the air within the enclosure exhausted as needed.

Air flowed continuously through the enclosure through holes in the sides. The inlet hole was dampered to provide the desired pressure across the firestop. Flow through the inlet hole was diverted toward the walls of the enclosure away from the sample and penetrating items to minimize convection cooling.

2.4 INSTRUMENTATION:

Unexposed Surface Temperatures

Temperatures on the unexposed surface of the firestop were measured with No. 28 gauge chromel-alumel thermocouples. Each thermocouple bead was held against the surface and covered with an 0.75 by 0.75 by 0.156 in. (19 by 19 by 4 mm) asbestos pad.

Firestop Material Temperatures

Temperatures within the silicone elastomer and silicone foam materials were measured with No. 28 gauge chromel-alumel thermocouples with an 0.062 in. (1.6 mm) diameter inconel shield. Temperatures between layers of the device were measured with unshielded No. 28 gauge chromel-alumel thermocouples.

Furnace Temperatures

Furnace temperatures were measured with No. 14 AWG chromel-alumel thermocouples within a 3/4 in. (19 mm) steel pipe. The thermocouples were located 12 in. (305 mm) from the exposed surface of the slab and symmetrically distributed within the furnace chamber.

Pressure Differential

The pressure differential at the exposed surface with respect to the unexposed surface was measured with probes connected to a manometer or electron pressure gauge. The probes were located as shown in Fig. 4.

Data Acquisition System

Voltage outputs from the thermocouples were connected to an Accurex Autodata 9 data logger. Readings from the manometers and electronic pressure gauge were recorded manually.

Photography

Experiments were recorded on 35 mm color slides. The camera was an Olympus OM-2 with a 50 mm f 1.8 lens.

2.5 METHOD:

The fire experiments were conducted in accordance with IEEE 634, except for certain procedure details under investigation.

The relative humidity of the concrete slabs at a depth of 3 in. (wettest section) prior to experiment are given in Table 18. The installation of the firestop materials was completed at least 18 h prior to the start of the experiment.

Throughout each experiment, observations were made of the character of the fire and its control, the conditions of the unexposed surface, temperatures within the firestop materials and penetrating items, temperatures on the unexposed side and the pressure differential between the exposed and unexposed surfaces.

3. RESULTS AND DISCUSSION

3.1 GENERAL:

During each fire experiment, the furnace fire was luminous and well-distributed, and the furnace temperatures followed the Standard Time-Temperature Curve, except for Experiments 24-26 in which the furnace temperatures were controlled to a predetermined curve as shown in Fig. 5.

Each sample was subjected to the prescribed fire exposure until either flaming occurred on the exposed side or the desired information was obtained. The temperatures recorded during each fire experiment were extensive. Only those portions of data necessary for the specific objectives are discussed here. The locations of these thermocouples are described in Table 19.

3.2 PRESSURE DIFFERENTIAL EXPERIMENTS:

Discussion

In the interest of safety and convenience, organizations may be operating their furnaces used for testing firestops at a slight negative differential pressure. This condition of operation allows controlled exhaust of smoke and gases through the furnace stack while reducing the amount of smoke that escapes from the furnace and into the laboratory. This also reduces the smoke in the furnace so as to permit observations of the exposed side of the sample.

However, questions have been raised about the effect of operating furnaces at a negative pressure differential. The conjecture is that operating a furnace at a slight negative pressure differential provides a means for cool air from the laboratory to leak into the furnace through cracks or other openings in the furnace or sample. To limit these conditions, some have proposed that a positive pressure differential be used. They contend that this would be appropriate since it would better evaluate the firestop by providing a more severe fire condition with respect to the following:

- A. Unexposed surface temperatures
- B. Time at which flaming occurred on the unexposed side
- C. Formation of cracks in the firestop material
- D. Structural failure.

Additionally, if openings are present, the positive pressure differential would allow flames to penetrate through the holes.

To provide the data with respect to these questions, 24 experiments were conducted with the differential pressure ranging from -0.05 in. H₂O (-12 Pa) to +0.50 in. H₂O (+125 Pa). The silicone foam, silicone elastomer and the device were investigated with and without cables. Some samples were constructed with through holes in them in the form of cracks or holes in the firestop materials, or as empty holes in the concrete slab.

Results

Unexposed Surface Temperatures - For comparison, the temperatures of the unexposed surface at the center of the firestop material were plotted versus time for Experiments 1, 3, 5, 7 and 9 (Fig. 6) and for Experiments 2, 4, 6, 8 and 10 (Fig. 7).

The temperatures were about the same for each group of experiments, except for Experiment 9. This experiment is suspect as shown by the comparatively long duration (215 min vs. 117 for Experiment 3) without flame occurrence on the unexposed side.

Flame Occurrence - The times when flaming was observed are shown in Table 20. For Experiments 3, 5 and 7, the times when flaming occurred were about the same. The physical performance during Experiments 1 and 9 were significantly different than the other experiments (3, 5 and 7). In Experiment 1, the char layer that formed at the exposed surface of the silicone material quickly passed through the material while in Experiment 9, the char layer formed, but remained at the exposed surface. This may have been caused by variances in the air cell structure of the material that developed during installation and cure or due to other differences in material properties that developed during installation.

For Experiments 20 and 23, the time when flaming occurred was about the same (154 min and 153 min, respectively), even though Experiment 20 was at -0.05 in. H₂O (-12 Pa) and Experiment 23 at +0.01 in. H₂O (+2 Pa). However, the way flaming occurred in Experiment 20 was different. In Experiment 23, the material cracked and collapsed with the unexposed surface then igniting. In Experiment 20, the material cracked and collapsed, but since the flames from the furnace were being drawn downward due to the negative pressure, the unexposed surface of the material did not ignite. However, the radiant energy from the furnace ignited the cables on the unexposed side of the sample.

Flaming did not occur on the unexposed side during any of the experiments with the silicone elastomer and device.

Crack Formation and Structural Integrity - The same pattern of crack formation and structural collapse of the silicone material were observed in Experiments 1, 3, 5, 7, 10, 19 and 23 where flaming occurred. In all these experiments, propagation of a crack through the material was rapid, usually occurring within 5 min after crack formation. Collapse of the material occurred immediately after the crack had propagated through the material.

Openings/Flaming - Experiments 21 and 22 were conducted with two nominal 0.50 in. (12 mm) diameter holes in the silicone material created by pulling cables from the firestop after the material had been installed and cured. Experiment 21 was conducted at 0.01 in. H₂O (+2 Pa) pressure differential, while Experiment 22 was conducted at -0.05 in. H₂O (-12 Pa). During Experiment 21, smoke and hot gases issued through the holes, but flames were not seen. After about 15 min, the cable jacket/insulation materials surrounding the holes were seen melting. The gases that issued through the holes were rich in unburned fuel and could be ignited by a match. During Experiment 22, smoke and hot gases were not observed as in Experiment 21. However, after 27 min, the cable-jacket/insulation material surrounding the holes began to melt, probably due to the radiant heat from the furnace, which produced smoke on the unexposed side.

In Experiment 51, there were four holes in the concrete slab which were left unfilled. During the experiment, flames were seen issuing from each hole, but the time when they first appeared was different for each hole size. The times and the differential pressure at the observed flaming times are given in Table 21.

3.3 FIRE EXPOSURE:

Discussion

There has been interest as to the effect on firestop performance, if the firestop is exposed to a fire other than the Standard Time-Temperature Curve (ASTM E119) that is used in investigating fire resistance ratings for building assemblies. The Standard Time-Temperature Curve was developed during the early 1900's and was based upon temperatures found in the various stages of growth of actual fires in buildings. Typically, the fuel load for these fires would have wood furniture and paper with windows that provided ventilation for the fire. This exposure may not be applicable for fires in nuclear power plants since the fuel load in the plants usually consist of synthetic combustibles and the ventilation is limited.

To provide data, Experiments 24-26 were conducted using a time-temperature curve less than the Standard Time-Temperature Curve defined in ASTM E119 (Fig. 5).

Results

Unexposed Surface Temperatures - The temperatures of the unexposed surface were plotted versus time for Experiments 23-26 and 49 and are shown in Fig. 8-12. As shown, the temperatures for Experiments 24, 25 and 26 using the less (sever) temperature curve were cooler than Experiments 23 and 49 using the Standard Temperature Curve.

Flame Occurrence - The times when flaming was observed are shown in Table 22. As shown, flaming occurred later in Experiments 24 and 25 as compared to Experiment 23. No comparison could be made between Experiment 26 and Experiment 49 since flaming did not occur during the 270 min fire exposure period in Experiment 26.

3.4 SAMPLE CONSTRUCTION EXPERIMENTS:

Discussion

The construction parameters of firestop construction are numerous. The opening size, the location of the penetrating item within the opening and the type and number of penetrating items all can be different. The performance of the firestop can be different for different firestop constructions.

Experiments 27-50 were conducted to provide data to quantify the effects due to changes in firestop construction for those materials and penetrating items investigated. In twenty experiments, the penetrating items differed with respect to cable construction (conductor type, conductor size, insulation and jacket materials), conduit type and size, pipe size and cable loading. In four experiments, the size of the opening varied from 2 in. (51 mm) to 12 in. (305 mm).

Results

Conductor Size - The unexposed surface temperatures near the cable were plotted versus time. For Experiments 35, 39, 41 and 38, 40 and 42 were plotted versus time and are shown in Figs. 13 and 14. As shown, the temperatures were greater near the 300 MCM cable as compared to the 3C/12 AWG and 7C/12 AWG cables.

Conductor Type - The unexposed surface temperatures near the cable were plotted versus time for Experiments 35-38 and are shown in Figs. 15 and 16. As shown, the temperatures were greater near the copper conductor 300 MCM cable as compared to the aluminum conductor 300 MCM cable.

Cable Jacket-Insulation Materials - The conductor temperatures at the unexposed surface were plotted versus time for Experiments 31-34 and 39 are shown in Fig. 17. As shown, the temperatures were the greatest for Cable A compared to Cables G, H and F.

Also, each cable construction performed differently as the cable temperature on the unexposed side increased. Cable A melted and dripped with the molten material slowly coagulating into a puddle on the firestop material. Cable G swelled and cracked near the unexposed surface but did not melt. Cable H swelled like Cable G but did not crack.

Pipe Size - The temperatures at the firestop material/pipe interface were plotted versus time for Experiments 43 and 44 as shown in Fig. 18. These data show that the temperatures were greater at the 3 in. (76 mm) pipe as compared to the 1 in. (25 mm) pipe.

Conduit Type and Size - The temperatures at the firestop material/conduit interface were plotted versus time for Experiments 45-48, as shown in Fig. 19. As shown, the temperatures were greater at the material/conduit interface for the 3 in. (76 mm) conduits as compared to the 1 in. (25 mm) conduits. Also, temperatures were greater at the material/conduit interface for the aluminum conduit than for the steel conduit.

Cable Loading - The temperatures on the firestop material near the cables were plotted versus time for Experiments 49 and 50, in Fig. 20. The graph indicates that the temperatures were greater in Experiment 50 with three layers of cables as compared to Experiment 49 with one layer of cables.

Opening Size - The times when flaming occurred are shown in Table 23. Comparing the performance of the firestop material in Experiments 27-30, it was noted that the Experiments with the larger holes (6 in. (152 mm), 9 in. (230 mm) and 12 in. (305 mm)), the material tended to deflect downward at the center of the opening during fire exposure. The greatest deflection was for the material in the 12 in. (305 mm) hole and with the deflection being greater for the 9 in. (230 mm) hole compared to the 6 in. (152 mm) hole. The deflection tended to affect the performance of the material by causing cracks about the periphery of the hole, which in turn decreased the strength of the material and increased the deflection.

4. FINDINGS

The data and related analysis generated through this investigation and presented in this Report, lead to certain findings, substantiated by the experimental data.

4.1 DIFFERENTIAL PRESSURE:

For those materials that remained integral during fire exposure and did not allow a path for gas flow, the effect of changing the differential pressure was not significant.

(When the firestop materials remained integral, changing the differential pressure between -0.05 in. H₂O (-12 Pa) to +0.50 in. H₂O (+125 Pa) did not significantly change the unexposed surface temperatures of the firestop materials, the time when flaming occurred on the unexposed side, the formation of cracks in the firestop materials or the structural failure of the firestop materials. See Pages 10-11.)

For those materials with pre-formed holes, positive differential pressure provided a means for smoke and hot gases to penetrate through to the unexposed side.

(When holes were created in the firestop material prior to the test, positive differential pressure provided a means for gases to penetrate through the holes to the unexposed side. These gases were rich in unburned fuel and could be ignited by a match. When a negative pressure differential was used, smoke and hot gases were not observed, but the cables near the holes melted and issued smoke, probably due to the radiant heat from the furnace. See Page 11.)

With a positive pressure differential, flames penetrated through larger diameter holes sooner than through smaller diameter holes.

(During a test with positive pressure, the times when flames were observed through holes in a slab were inversely related to hole size. See Page 11.)

4.2 FIRE EXPOSURE:

When a less severe fire exposure was used, the rate of heat transmission to the unexposed surface was less and time to flaming failure longer.

(The unexposed surface temperatures for firestop materials subjected to a "cooler" time-temperature furnace curve were less than for firestop materials subjected to the Standard Time-Temperature Furnace Curve. Also for the silicone foam material, flaming occurred later for the "cooler" curve experiments as compared to the standard curve experiments. See Page 12.)

4.3 SAMPLE CONSTRUCTION:

Increasing the gauge (diameter) of the conductor of a cable, increased the unexposed surface temperature of the firestop material near the wire or cable.

(The unexposed surface temperatures of the firestop material were greater near the 300 MCM conductor than the 3C/12 AWG cable. See Page 12.)

The unexposed surface temperatures near cables were greater when the cable conductors were copper as compared to aluminum conductors.

(The temperatures were greater near the copper conductor 300 MCM cable as compared to the aluminum conductor 300 MCM cable. See Page 13.)

The conductor temperatures at the unexposed surface were different for cables of the same size, but of different jacket and insulation materials.

(The conductor temperatures were the greatest for Cable A as compared to Cables G, H and F. See Page 13.)

Each cable construction performed differently as the cable temperature on the unexposed side increased.

(The performance of the jacket and insulation materials in response to increased temperatures was different for the cable constructions tested with the same conductor size. See Page 13.)

The temperatures at the firestop material/pipe interface were greater for larger size pipe.

(The temperatures were greater for the 3 in. (76 mm) pipe as compared to the 1 in. (25 mm) pipe. See Page 13.)

The temperatures at the firestop material/conduit interface were greater for larger size conduit and were greater for aluminum as compared to steel conduit.

(The temperatures were greater for the 3 in. (76 mm) conduits as compared to the 1 in. (25 mm) conduits. Also, the temperatures were greater for the aluminum conduit as compared to the steel conduit. See Page 13.)

The temperatures on the firestop material near a cable bundle increased as the number of cables increased.

(The temperatures were greater near three layers of cables as compared to a single layer bunch. See Page 13.)

The material deflection during fire exposure increased with increasing hole size.

(The deflection was the greatest for the 12 in. (305 mm) hole as compared to the 9 in. (230 mm) and 6 in. (152 mm) holes. See Page 14.)

5. REFERENCES

1. U.S. Nuclear Regulatory Commission, "Water Reactor Safety Research Program," USNRC Report NUREG-0006, February 1979. Available for purchase from National Technical Information Service, Springfield, Virginia 22161.
2. "Physical Independence of Electric Systems, Revision 1," U.S. Nuclear Regulatory Commission, Regulatory Guide 1.75, Washington, D.C., January 1975. Available for purchase from National Technical Information Service, Springfield, Virginia 22161.
3. U.S. Nuclear Regulatory Commission, "Recommendations Related to Browns Ferry Fire," USNRC Report NUREG-0050, February 1976. Available for purchase from National Technical Information Service, Springfield, Virginia 22161.
4. U.S. Nuclear Regulatory Commission, "Guidelines for Fire Protection for Nuclear Power Plants Docketed Prior to July 1, 1976," Appendix A to Branch Technical Position APCS 9.5-1. Available for inspection and copying for a fee in the NRC Public Document Room.
5. U.S. Nuclear Regulatory Commission, "Guidelines for Fire Protection for Nuclear Power Plants," Branch Technical Position APCS 9.5-1. Available for inspection and copying for a fee in the NRC Public Document Room.
6. "Standard Methods of Fire Tests of Building Construction and Materials," ASTM E119-82. Available for purchase from the American Society for Testing and Materials, 1916 Race Street, Philadelphia, PA 19103.
7. "IEEE Standard Cable Penetration Fire Stop Qualification Test," IEEE 634-1978. Available for purchase from the Institute of Electrical and Electronics Engineers, Inc., 345 East 47th Street, New York, NY 10017.

TABLE 1

Pressure Differential Experiments

<u>Experiment</u>	<u>Sample Reference*</u>	<u>Pressure In H₂O (Pa)</u>	<u>Firestop Material</u>	<u>Cable Construction**</u>	<u>Number</u>
9	100	+0.01 (+2)	SF	A	3
1	100	+0.05 (+12)	SF	A	3
3	100	+0.05 (+12)	SF	A	3
5	100	+0.05 (+125)	SF	A	3
7	100	+0.50 (+125)	SF	A	3
10	100	+0.01 (+2)	SF	None	
2	100	+0.05 (+12)	SF	None	
4	100	+0.05 (+12)	SF	None	
6	100	+0.25 (+62)	SF	None	
8	100	+0.50 (+125)	SF	None	
12	101	+0.50 (+125)	SR	A	3
11	101	+0.01 (+2)	SR	A	3
14	101	+0.50 (+125)	SR	None	
12	101	+0.01 (+2)	SR	None	
15	102	+0.05 (+12)	D	A	3
17	102	+0.50 (+125)	D	A	3
16	102	+0.05 (+12)	D	None	
18	102	+0.50 (+125)	D	None	

SF = Silicone foam
 SR = Silicone elastomer
 D = Firestop Device

* = See Table 11.

** = See Table 9.

TABLE 2

Pressure Differential Experiments - Cracks and Holes

<u>Experiment</u>	<u>Sample Reference*</u>	<u>Pressure In H₂O (Pa)</u>	<u>Firestop Material</u>	<u>Cable Construction**</u>	<u>Number</u>
23	103	+0.01 (+2)	SF	B	1
20	103	-0.05 (-12)	SF	B	1
19	103	+0.50 (+125)	SF	B	1
21	103	+0.015 (+3)	SR	B	31
22	103	-0.05 (-12)	SR	B	31

SF = Silicone foam

SR = Silicone elastomer

* = See Table 12.

** = See Table 9.

TABLE 3

Fire Exposure Experiments

<u>Experiment</u>	<u>Sample Reference*</u>	<u>Firestop Material</u>	<u>Cable Construction**</u>	<u>Number</u>
24	104	SF	B	1
25	104	SF	P	1
26	105	SR	A	11

SF = Silicone foam

SR = Silicone elastomer

* = See Table 13.

** = See Table 9.

TABLE 4

Sample Experiments - Conductor Construction & Size

<u>Experiment</u>	<u>Sample Reference*</u>	<u>Firestop Material</u>	<u>Cable</u>	
			<u>Construction**</u>	<u>Number</u>
35	106	SR	C	1
36	106	D	C	1
37	107	SR	E	1
38	107	D	E	1
41	109	SR	B	1
39	108	SR	F	1
42	109	D	B	1
40	108	D	F	1

SR = Silicone elastomer

D = Device

* = See Table 14.

** = See Table 9.

TABLE 5

Sample Experiments - Cable Construction

<u>Experiment</u>	<u>Sample Reference*</u>	<u>Firestop Material</u>	<u>Cable Construction**</u>	<u>Number</u>
31	110	SR	A	1
33	111	SR	G	1
34	111	SR	H	1
32	110	D	A	1

SR = Silicone elastomer
D = Device

* = See Table 14.

** = See Table 9.

TABLE 6

Sample Experiments - Conduit or Pipe Type & Size

<u>Experiment</u>	<u>Sample Reference*</u>	<u>Firestop Material</u>	<u>Cable per Item</u>		<u>Pipe or Conduit</u>	
			<u>Construction**</u>	<u>Number</u>	<u>Number</u>	<u>Size, in. (mm)</u>
43	112	SR	None		3	1 (25)
44	112	SR	None		2	3 (76)
45	113	SR	A	1	3	1 (25)
47	114	SR	A	1	3	1 (25)
46	113	SR	A	3	2	3 (76)
48	114	SR	A	3	2	3 (76)

SR = Silicone elastomer

* = See Table 15

** = See Table 9

TABLE 7

Sample Experiments - Cable Loading

<u>Experiment</u>	<u>Sample Reference*</u>	<u>Firestop Material</u>	<u>Cable Construction**</u>	<u>Number</u>
49	115	SR	A	11
50	116	SR	A	33

SR = Silicone elastomer

* = See Table 16.

** = See Table 9.

TABLE 8

Sample Experiments - Size

<u>Experiment</u>	<u>Sample Reference*</u>	<u>Firestop Material</u>	<u>Hole Size, in. (mm)</u>
27	117	SF	2 (51)
28	117	SF	6 (152)
29	118	SF	9 (230)
30	119	SF	12 (305)

SF = Silicone foam

* = See Table 17.

TABLE 9

Cable Constructions

<u>Conductor</u>		<u>Cable Cross</u>	<u>Insulation/Jacket</u>	<u>Approximate</u>	<u>Cable</u>	<u>Approximate</u>
<u>No./Size</u>	<u>Type</u>	<u>Section</u>	<u>Material</u>	<u>Conductor</u>	<u>Jacket Material</u>	<u>Cable</u>
		<u>Diameter,</u>		<u>Insulation/</u>		<u>Jacket</u>
		<u>in. (mm)</u>		<u>Jacket</u>		<u>Thickness,</u>
				<u>Thickness,</u>		<u>in. (mm)</u>
				<u>in. (mm)</u>		
7/12 AWG	Cu	0.785 (19.9)	Ethylene propylene rubber/chloro- sulphonated poly- ethylene	0.028/0.017 (0.71/0.43)	Chlorosulphonated polyethylene	0.134 (3.4)
7/12 AWG	Cu	0.493 (12.5)	Crosslinked polyolefin/none	0.030/- (0.76/-)	Crosslinked polyolefin	0.054 (1.4)
7/12 AWG	Cu	0.602 (15.3)	Polyethylene/ Polyvinyl chloride	0.029/0.012 (0.74/0.31)	Polyvinyl chloride	0.062 (1.6)
7/12 AWG	Cu	0.515 (13.1)	Polyvinyl chloride nylon	0.022/0.006 (0.56/0.15)	Polyvinyl chloride	0.050 (1.3)
3/12 AWG	Cu	0.445 (11.3)	Polyethylene/ Polyvinyl chloride	0.039/0.012 (0.99/0.30)	Polyvinyl Chloride	0.056 (1.42)
300 MCM	Cu	0.821 (10.8)	Polyvinyl chloride	0.149 (2.78)	None	None
300 MCM	Al	0.832 (21.1)	Polyvinyl chloride	0.140 (3.56)	None	None
350 MCM	Cu	0.884 (22.5)	Polyvinyl chloride	0.100 (2.54)	None	None

Identification of materials was based upon the manufacturer's product literature.

TABLE 10

Conduit and PipesConduit

<u>Trade Size</u> <u>in. (mm)</u>	<u>Material</u> <u>Type</u>	<u>Inside Diameter</u> <u>in. (mm)</u>	<u>Wall Thickness</u> <u>in. (mm)</u>
1 (25)	Steel	1.049 (26.6)	0.133 (3.38)
1 (25)	Aluminum	1.049 (26.6)	0.133 (3.38)
3 (76)	Steel	3.068 (77.9)	0.216 (5.49)
3 (76)	Aluminum	3.068 (77.9)	0.216 (5.49)

Pipes

<u>Trade Size</u> <u>in. (mm)</u>	<u>Material</u> <u>Type</u>	<u>Inside Diameter</u> <u>in. (mm)</u>	<u>Wall Thickness</u> <u>in. (mm)</u>
1 (25)	Steel	1.049 (26.6)	0.133 (3.38)
3 (25)	Steel	3.068 (77.9)	0.216 (5.49)

TABLE 11

Pressure Differential Samples

<u>Sample Reference</u>	<u>Floor Slab</u>		<u>Firestop Material</u>		<u>Hole 1 Cable</u>		<u>Hole 2 Cable</u>	
	<u>Type</u>	<u>No.</u>	<u>Type</u>	<u>Thickness, in. (mm)</u>	<u>Type</u>	<u>No.</u>	<u>Type</u>	<u>No.</u>
100	*	5	SF	6.0 (150)	A	3	None	
101	I	2	SR	6.0 (150)	A	3	None	
102	I	2	D	3.75 (95)	A	3	None	

SF = Silicone foam
 SR = Silicone elastomer
 D = Firestop device

TABLE 12

Pressure Differential Samples

<u>Sample Reference</u>	<u>Floor Slab</u>		<u>Firestop Material</u>		<u>Cable</u>	
	<u>Type</u>	<u>No.</u>	<u>Type</u>	<u>Thickness, in. (mm)</u>	<u>Type</u>	<u>No.</u>
103	II	2	SF	6.0 (150)	B	1
103**	II	1	SF	6.0 (150)	B	1
103***	II	2	SR	2.5 (64)	B	31

SF = Silicone foam
 SR = Silicone elastomer

** = Firestop formed with an 0.38 in. (10 mm) wide by 9.5 in. (240 mm) long by 4 in. (100 mm) deep crack, as seen from the unexposed side, along one edge of the opening.

*** = Firestop formed with two holes caused by pulling cables out after material had cured. Cable tray used as raceway for the cable bundle.

TABLE 13

Fire Exposure Samples

Sample <u>Reference</u>	<u>Floor Slab</u>		<u>Firestop Material</u>		<u>Cable</u>	
	<u>Type</u>	<u>No.</u>	<u>Type</u>	<u>Thickness,</u> <u>in. (mm)</u>	<u>Type</u>	<u>No.</u>
104	II	2	SF	6.0 (150)	B	1
105	II	1	SR	4.0 (100)	A	11

SF = Silicone foam

SR = Silicone elastomer

TABLE 14

Sample Construction - Conductor Type & Size

Sample Reference	Floor Slab		Hole 1				Hole 2			
	Type*	No.	Firestop Material		Cable*		Firestop Material		Cable*	
			Type	Thickness, in. (mm)	Construction	No.	Type	Thickness, in. (mm)	Construction	No.
106	I	1	SR	6.0 (150)	C	1	D	3.75 (95)	C	1
107	I	1	SR	6.0 (150)	E	1	D	3.75 (95)	E	1
108	I	1	SR	6.0 (150)	F	1	D	3.75 (95)	F	1
109	I	1	SR	6.0 (150)	B	1	D	3.75 (95)	B	1
110	I	1	SR	6.0 (150)	A	1	D	3.75 (95)	A	1
111	I	1	SR	6.0 (150)	G	1	SR	6.0 (150)	H	1

SR = Silicone elastomer

D = Firestop device

* = See Table 9

TABLE 15

Sample Construction - Conduit or Pipe

<u>Sample Reference</u>	<u>Floor Slab</u>		<u>Penetrating Items</u>			<u>Cable/Item Construction</u>	
	<u>Type</u>	<u>No.</u>	<u>Type</u>	<u>No.</u>	<u>Size**</u>	<u>Construction</u>	<u>No.</u>
112	II	1	Steel Pipe	3	1	None	
			Steel Pipe	2	3	None	
113	II	1	Steel Conduit	3	1	A	1
			Steel Conduit	2	3	A	3
114	II	1	AL Conduit	3	1	A	1
			AL Conduit	2	3	A	3

Silicone elastomer, 4.0 in. (100 mm) thick, used as firestop material.

** = Trade Size (in.)

TABLE 16

Sample Construction - Cable Loading

<u>Sample Reference</u>	<u>Floor Slab</u>		<u>Cable</u>		<u>Firestop Material</u>	
	<u>Type</u>	<u>No.</u>	<u>Construction</u>	<u>No.</u>	<u>Type</u>	<u>Thickness, in. (mm)</u>
115	I	1	A	11	SR	4.0 (101)
116	I	1	A	33	SR	4.0 (101)

Cables installed in a 6 in. wide cable tray.

SR = Silicone elastomer

* = See Table 9

TABLE 17

Sample Constructions - Opening Sizes

<u>Sample Reference</u>	<u>Floor Slab</u>		<u>Opening</u>	<u>Firestop Material</u>	
	<u>Type</u>	<u>No.</u>	<u>Size in. (mm)</u>	<u>Type</u>	<u>Thickness, in. (mm)</u>
117	III	1	2 (51) and 6 (150)	SF	6.0 (150)
118	IV	1	9 (230)	SF	6.0 (150)
119	V	1	12 (300)	SF	6.0 (150)

All samples installed without cables.

SF = Silicone foam

TABLE 18

Slab Humidities

<u>Experiments</u>	<u>Slab Humidity Prior to Experiments, percent</u>
1, 2	75
3, 4	71
5, 6	75
7, 8	74
9, 10	74
11, 12	73
13, 14	70
15, 16	74
17, 18	74
19	64
20	67
21	60
22	62
23	64
24	61
25	60
26	62
27, 28	70
29	70
30	67
31, 32	73
33, 34	66
35, 36	74
37, 38	71
39, 40	73
41, 42	69
43, 44	66
45, 46	61
47, 48	61
49	66
50	61
51	60

TABLE 19

Thermocouple Locations

<u>Figure</u>	<u>Thermocouple No.</u>	<u>Location</u>
6	33	On unexposed surface of firestop material at the center
7	28	On unexposed surface of firestop material at the center.
8	24	On unexposed surface of firestop material on N-S centerline 3 in. from north edge.
	25	On unexposed surface of firestop material on E-W centerline 3 in. from east edge.
9	22	On unexposed surface of firestop material 1/2 in. from cable
	23	On unexposed surface of firestop material 3/4 in. from cable
10	24	On unexposed surface of firestop material on N-S centerline 3 in. from north edge.
	25	On unexposed surface of firestop material on E-W centerline 3 in. from east edge.
11	22	On unexposed surface of firestop material 1/2 in. from cable
	23	On unexposed surface of firestop material 3/4 in. from cable
12	26	On unexposed surface of firestop material on N-S centerline 2-1/4 in. from south edge.
	27	On unexposed surface of firestop material on E-W centerline 1-1/2 in. from east edge.
13	29	On unexposed surface of firestop material 1/16 in. from cable
14	24	On unexposed surface of firestop material 1/16 in. from cable
15	29	On unexposed surface of firestop material 1/16 in. from cable
16	24	On unexposed surface of firestop material 1/16 in. from cable
17	8 or 2	In conductor at the unexposed surface
18	3 or 9	On 1 in. pipe at the unexposed surface
	15 or 21	On 3 in. pipe at the unexposed surface
19	3 or 9	On 1 in. conduit at the unexposed surface
	15 or 21	On 3 in. conduit at the unexposed surface
20	41 or 43	On unexposed surface of firestop material 1 in. from cable

TABLE 20

Duration and Time to Flaming
For Pressure Differential Experiments

<u>Experiment</u>	<u>Experiment Duration (min)</u>	<u>Time to Flaming (min)</u>
9	215	NR
1	88	86
3	117	116
5	112	110
7	113	112
10	215	208
2	88	NR
4	117	NR
6	112	NR
8	113	NR
13, 14	270	NR
11, 12	245	NR
15, 16, 17, 18	185	NR
23	155	153
20	156	154
19	106	104
21	125	*
22	125	NR

* - After 15 min, smoke, which issued through hole, was ignited by match several times during the experiment.

NR = Flaming did not occur during experiment.

TABLE 21

Flame Occurrence Time and PressureExperiment 51

<u>Hole Diameter, in. (mm)</u>	<u>Time, s</u>	<u>Pressure, in. H₂O (Pa)</u>
6.00	2	0.0007 (0.18)
3.00	560	0.0076 (1.88)
0.75	640	0.0123 (3.05)
0.50	780	0.0161 (4.02)

TABLE 22

Duration and Time to Flaming
for Fire Exposure Experiments

<u>Experiment</u>	<u>Duration (min)</u>	<u>Time to Flaming (min)</u>
24	180	177
25	212	211
26	270	NR

NR = Flaming did not occur during experiment.

TABLE 23

Duration and Time to Flaming
for Sample Experiments

<u>Experiment</u>	<u>Duration (min)</u>	<u>Time to Flaming (min)</u>
35, 36	245	NR
37, 38	245	NR
41, 39	245	NR
42, 40	245	NR
31, 32, 33, 34	245	NR
43, 44	270	NR
45, 47	270	NR
46, 48	170	NR
49, 50	270	NR
27	120	NR
28	120	119
29	132	131
20	125	124

NR = Flaming did not occur during experiment.

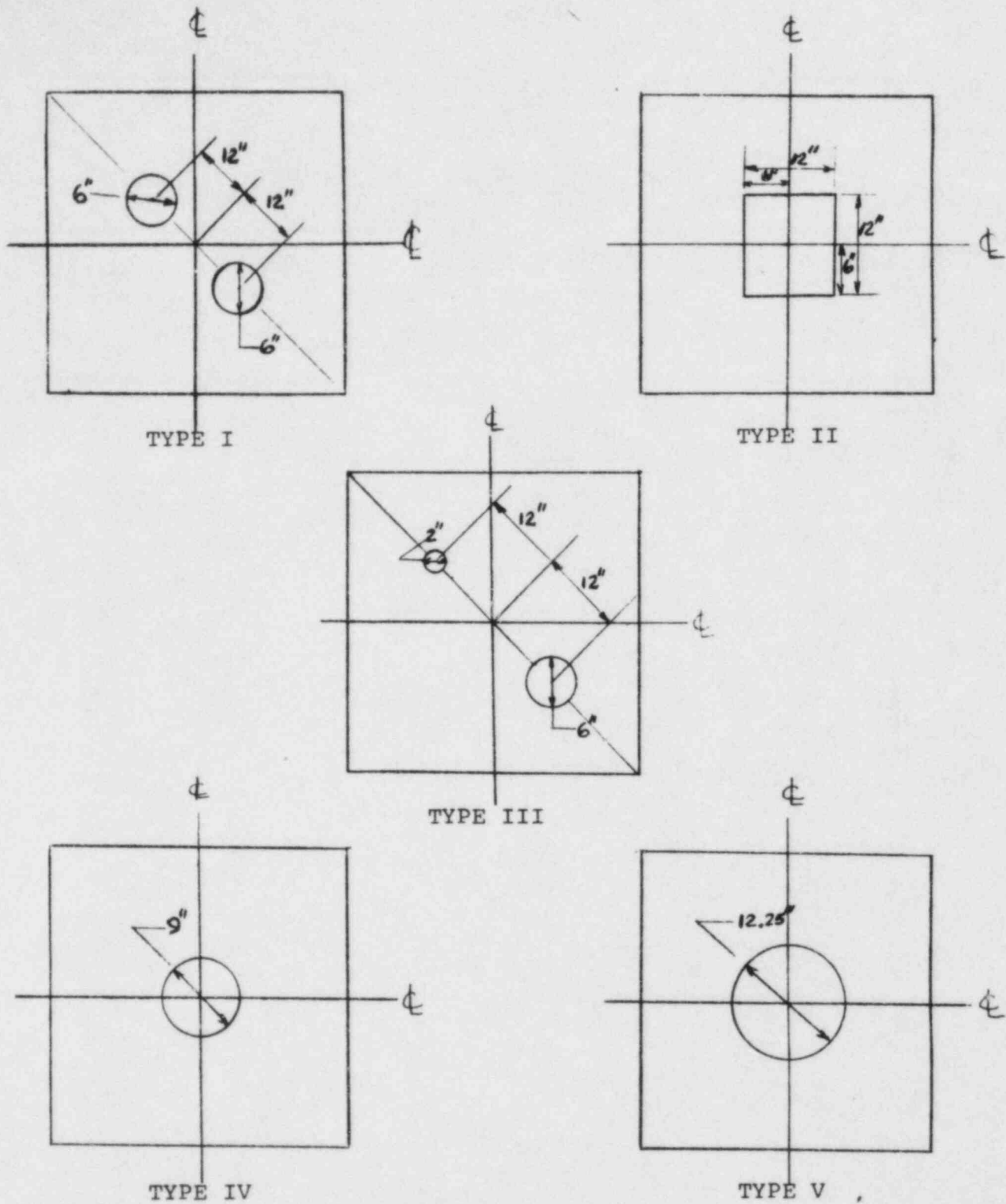

ALL SLABS - NOMINAL 36 x 36 x 6 IN. THICK

Figure 1 - Floor Slabs

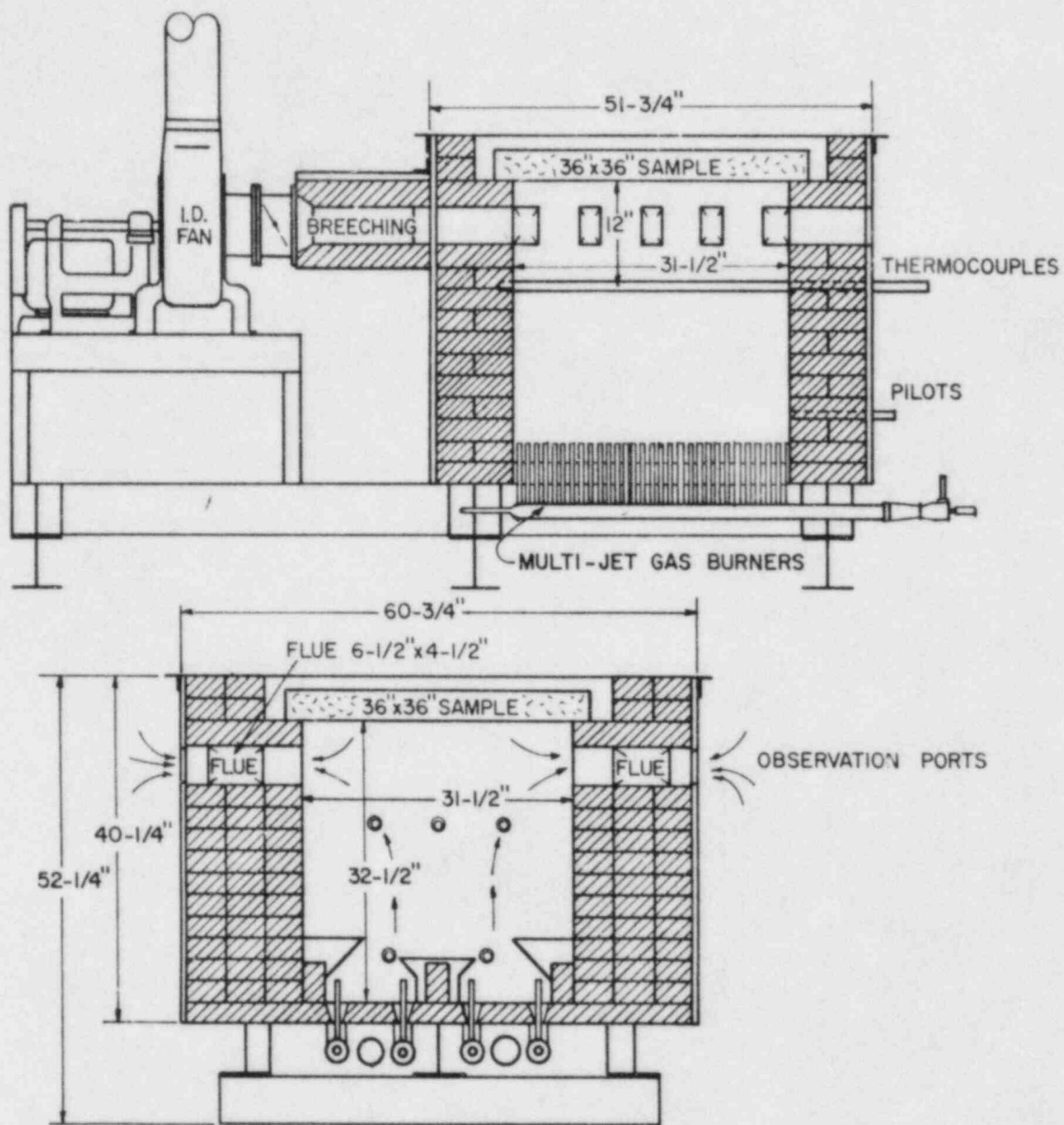
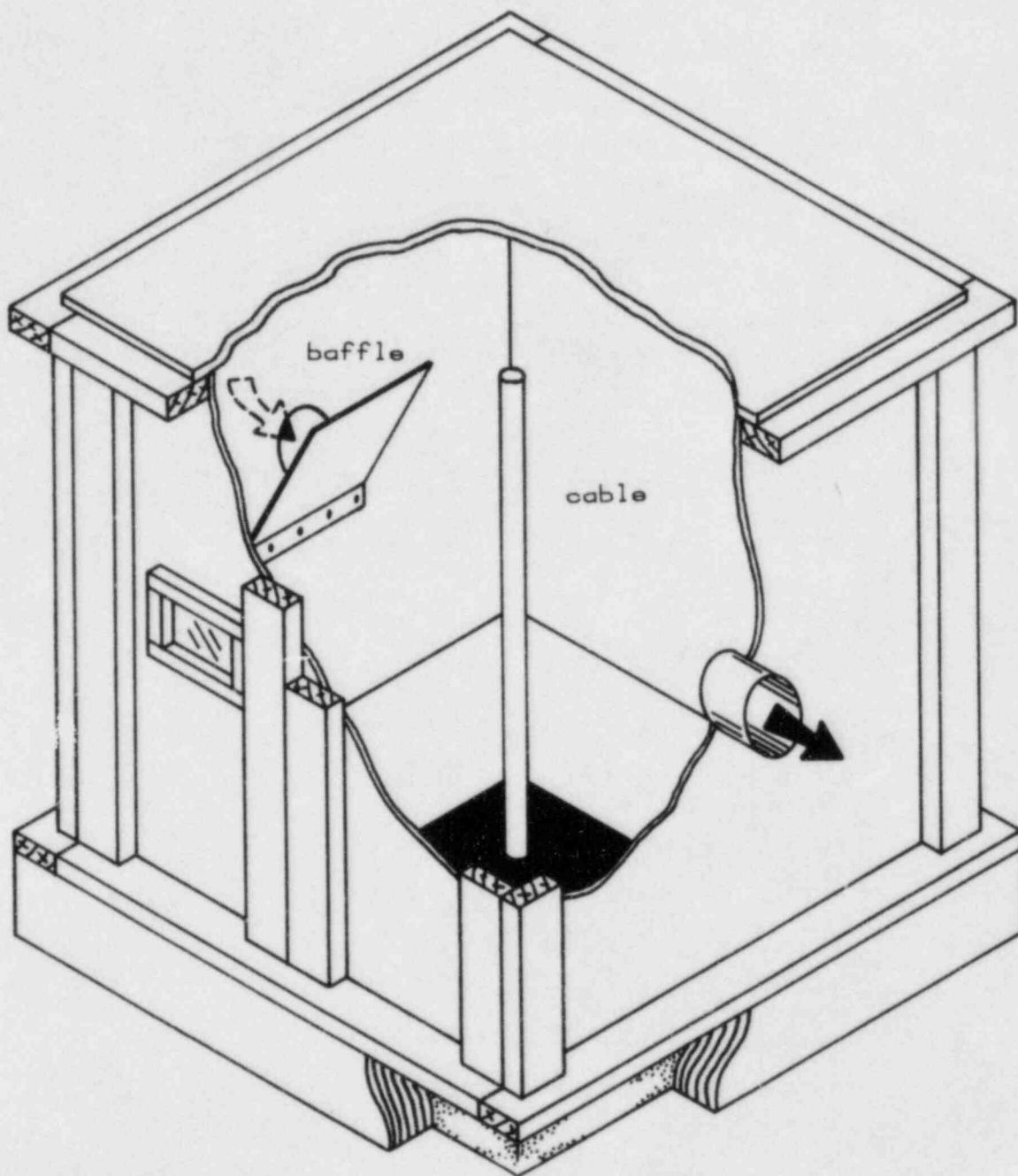

Figure 2 - Furnace



For positive pressure experiments of ≥ 0.25 in water (63 Pa) or greater, the enclosure was used with air exhausted from the enclosure. For negative pressure experiments (P8, P18), the enclosure was used with air forced into the enclosure. In the remaining experiments, the enclosure was not used.

Figure 3 - Enclosure

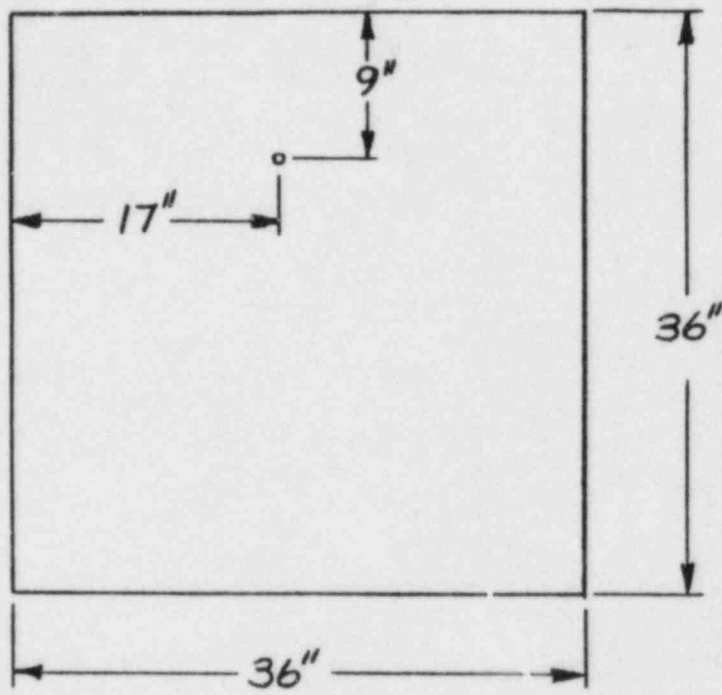

Figure 4 - Pressure Probe Locations

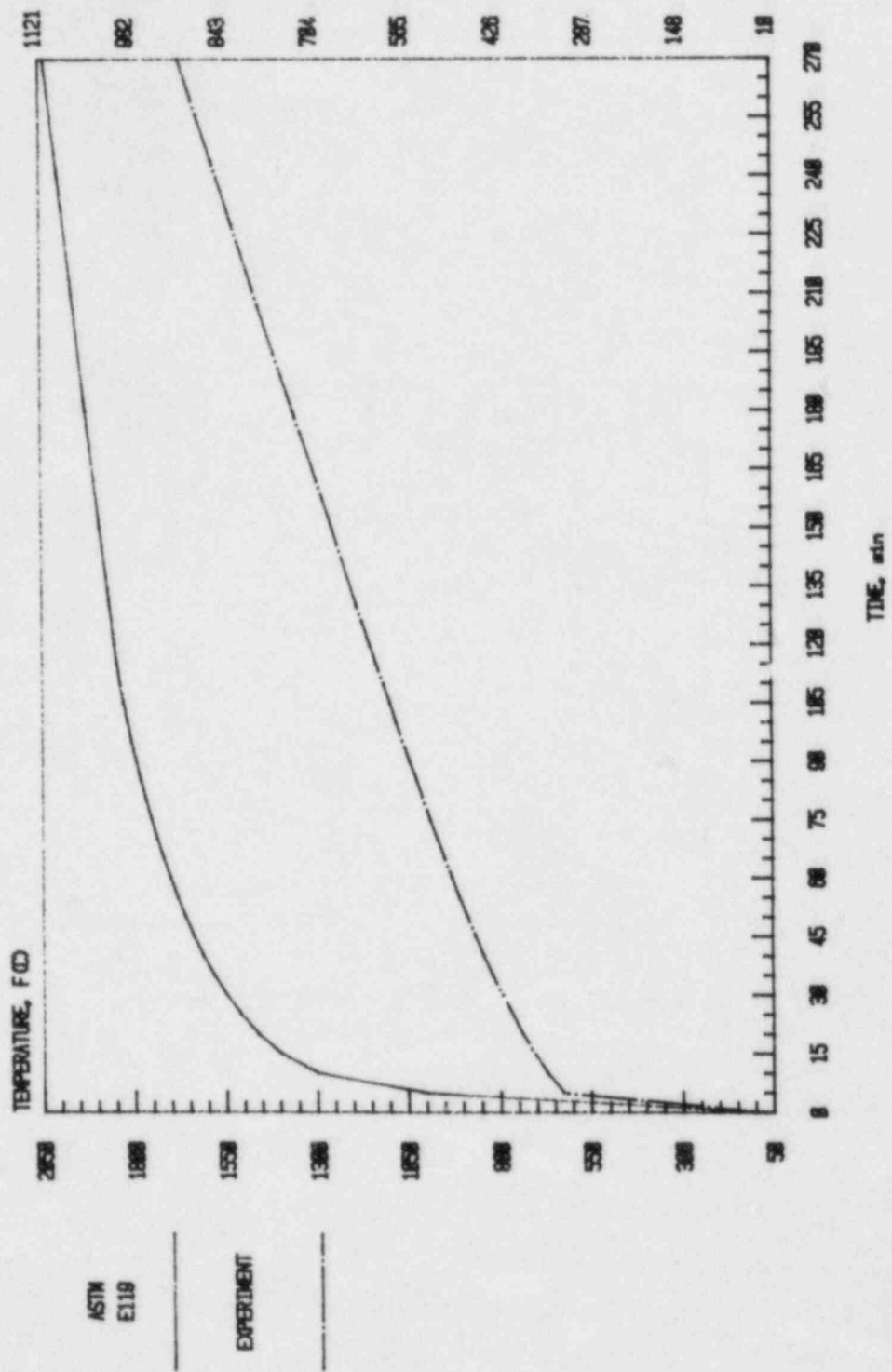

Figure 5 - Furnace Temperature Curves

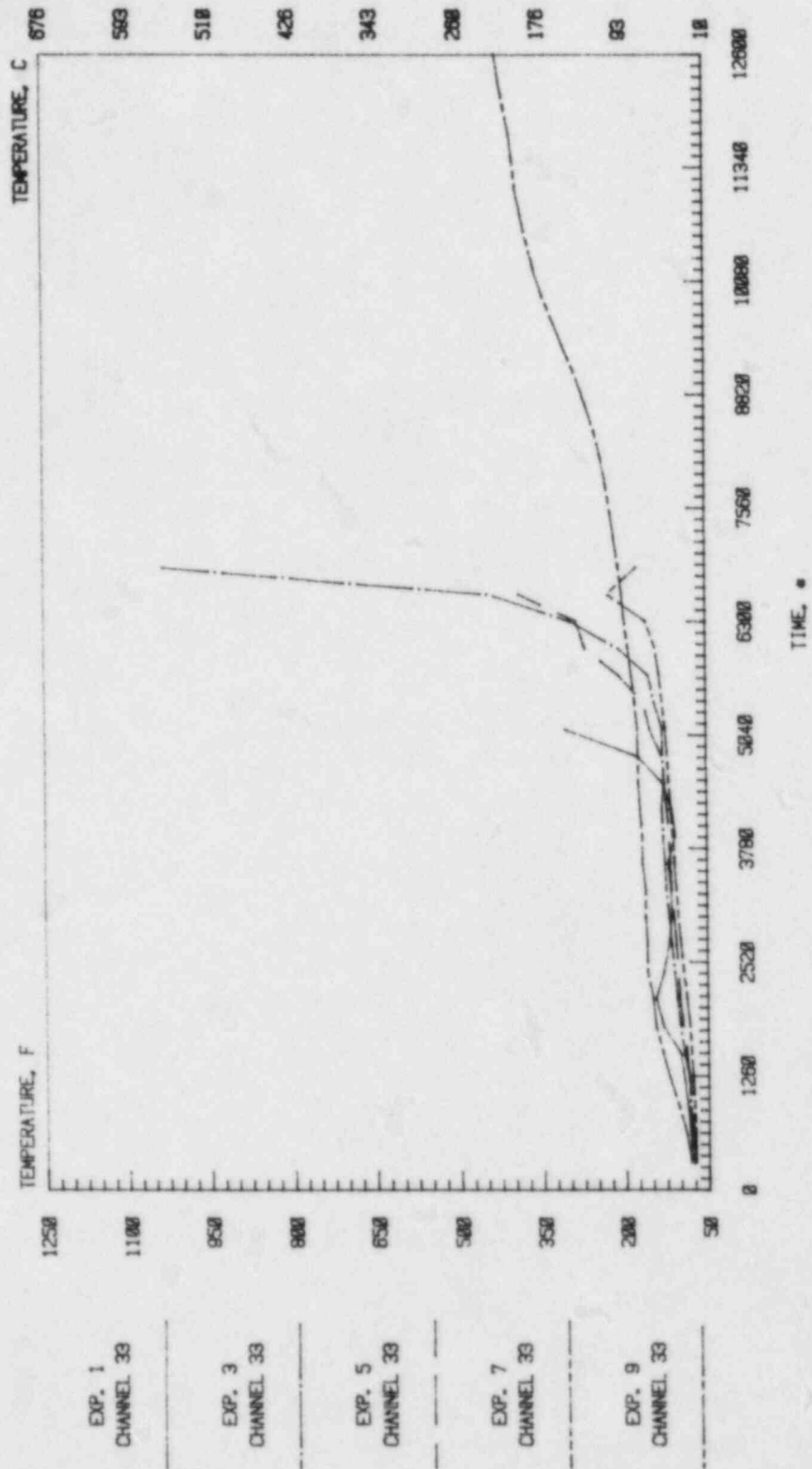

Figure 6 - Unexposed Surface Temperatures; Exps. 1,3,5,7 and 9

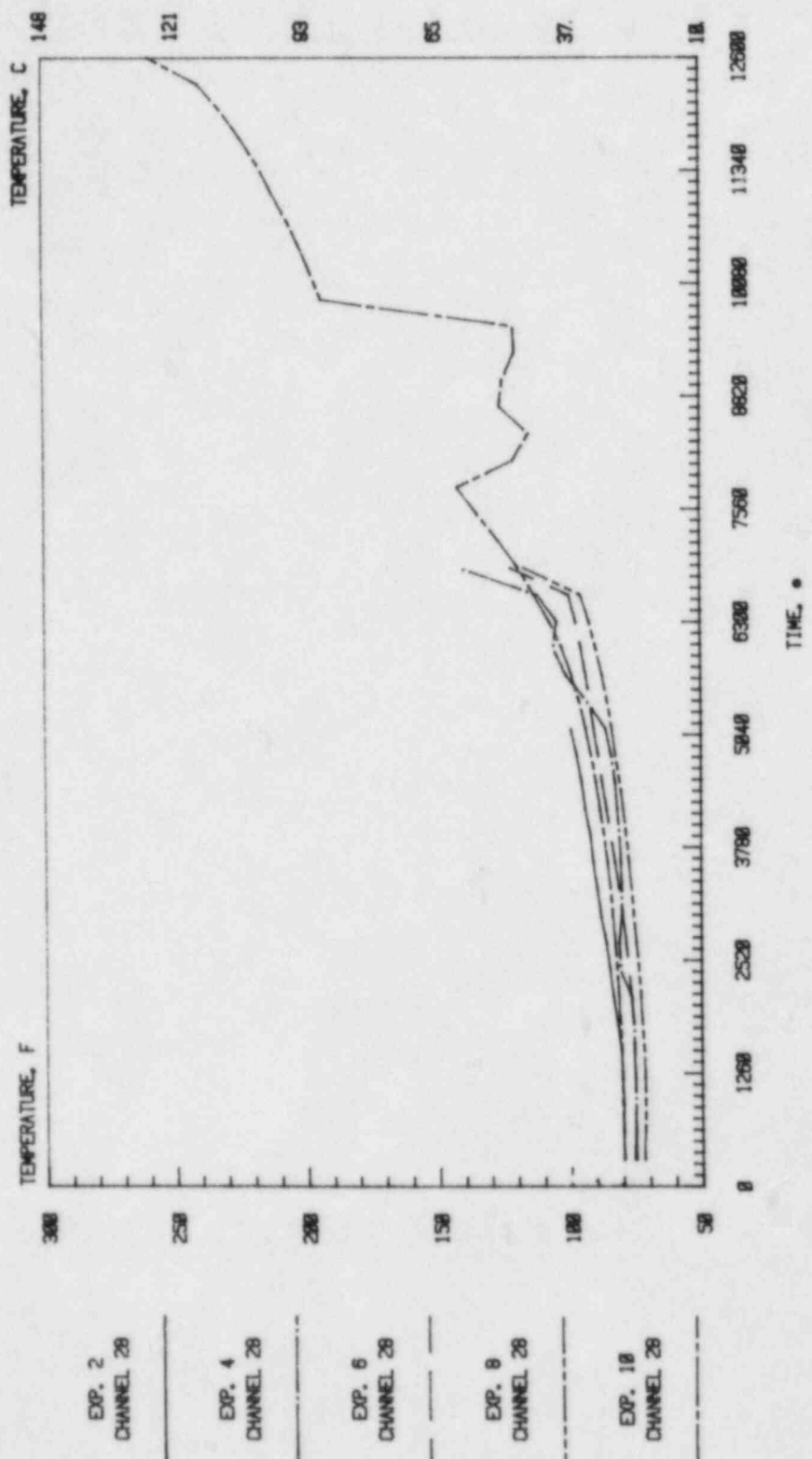

Figure 7 - Unexposed Surface Temperatures; Exps. 2,4,6,8 and 10

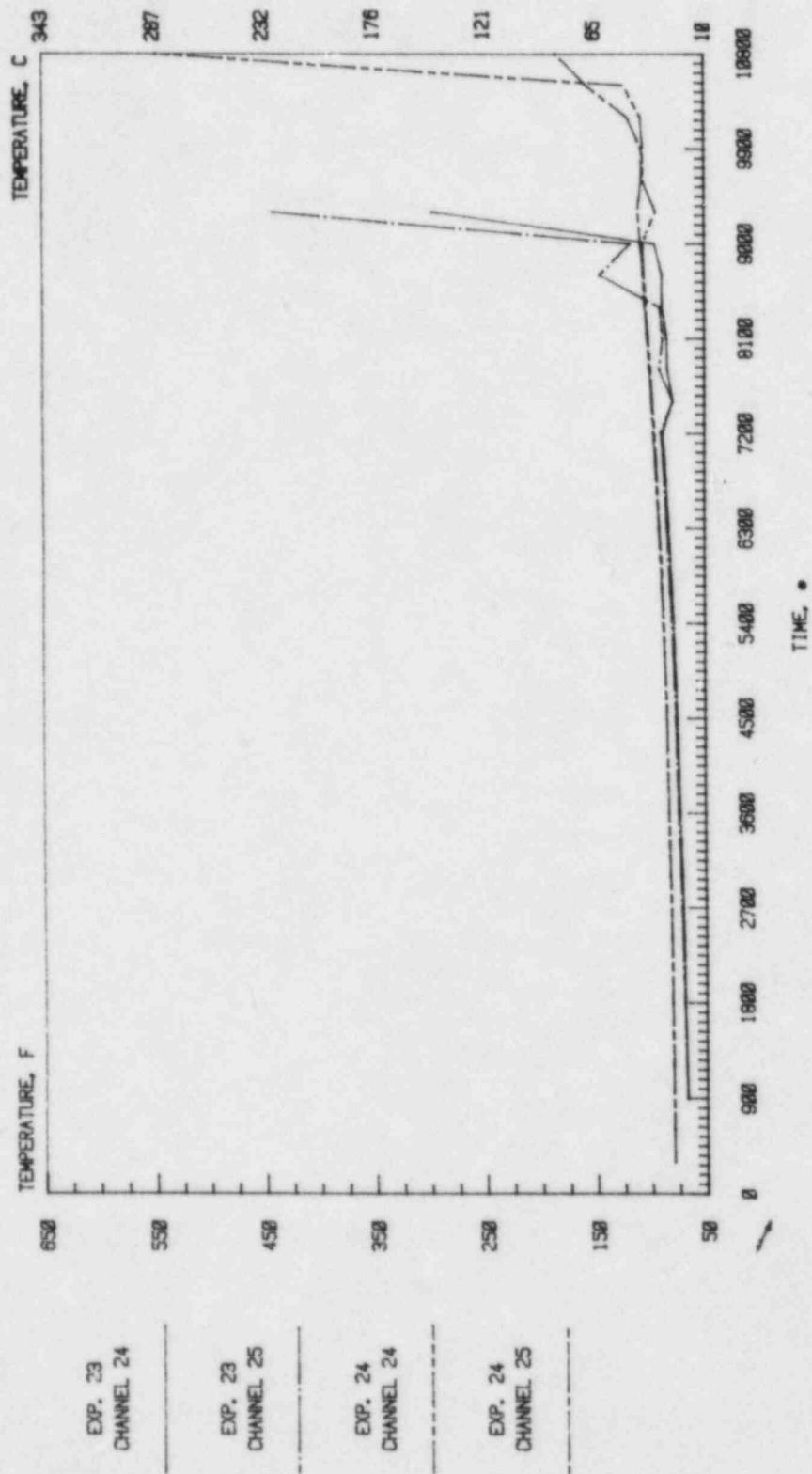

Figure 8 - Unexposed Surface Temperatures; Exps. 23 and 24

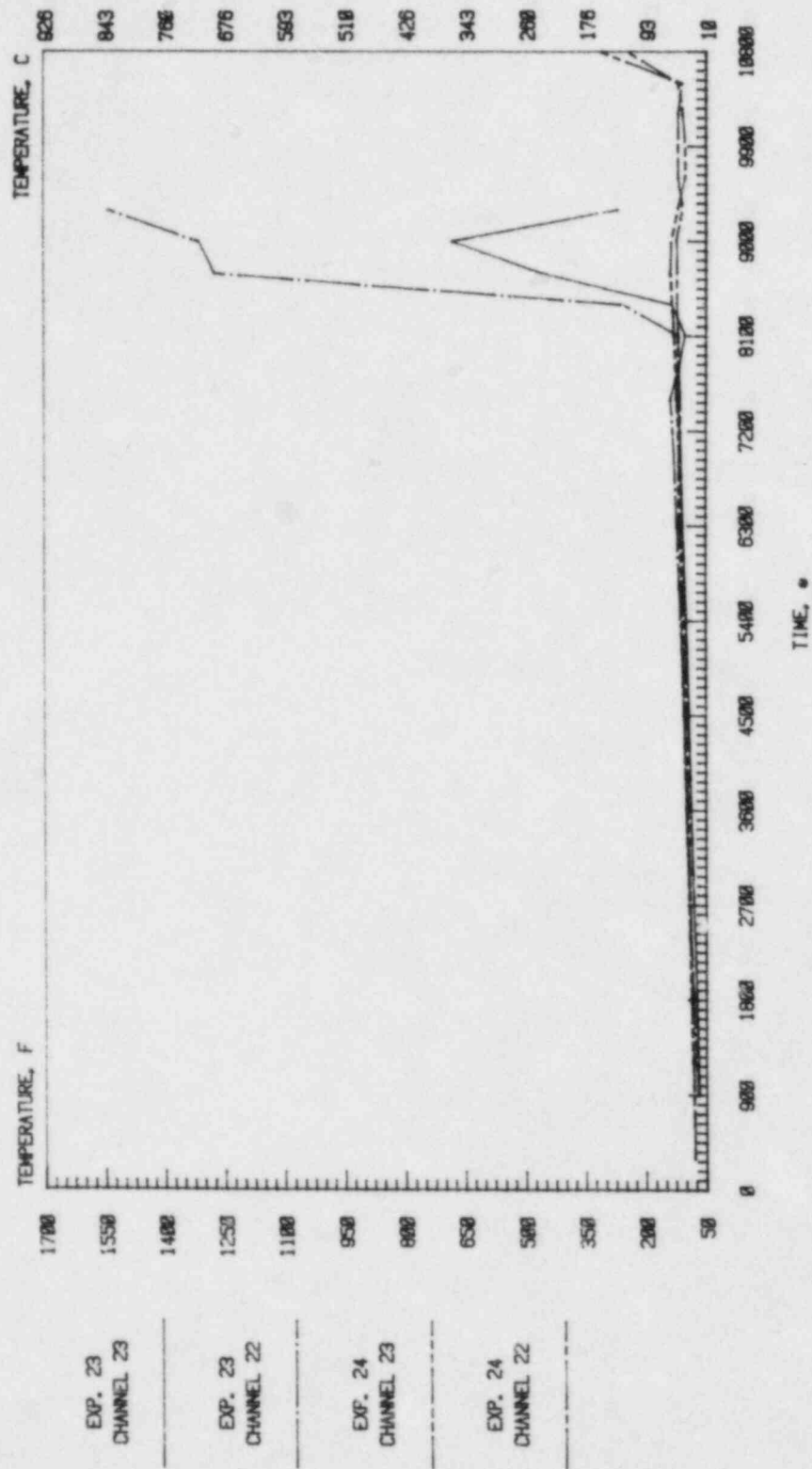

Figure 9 - Unexposed Surface Temperatures; Exps. 23 and 24

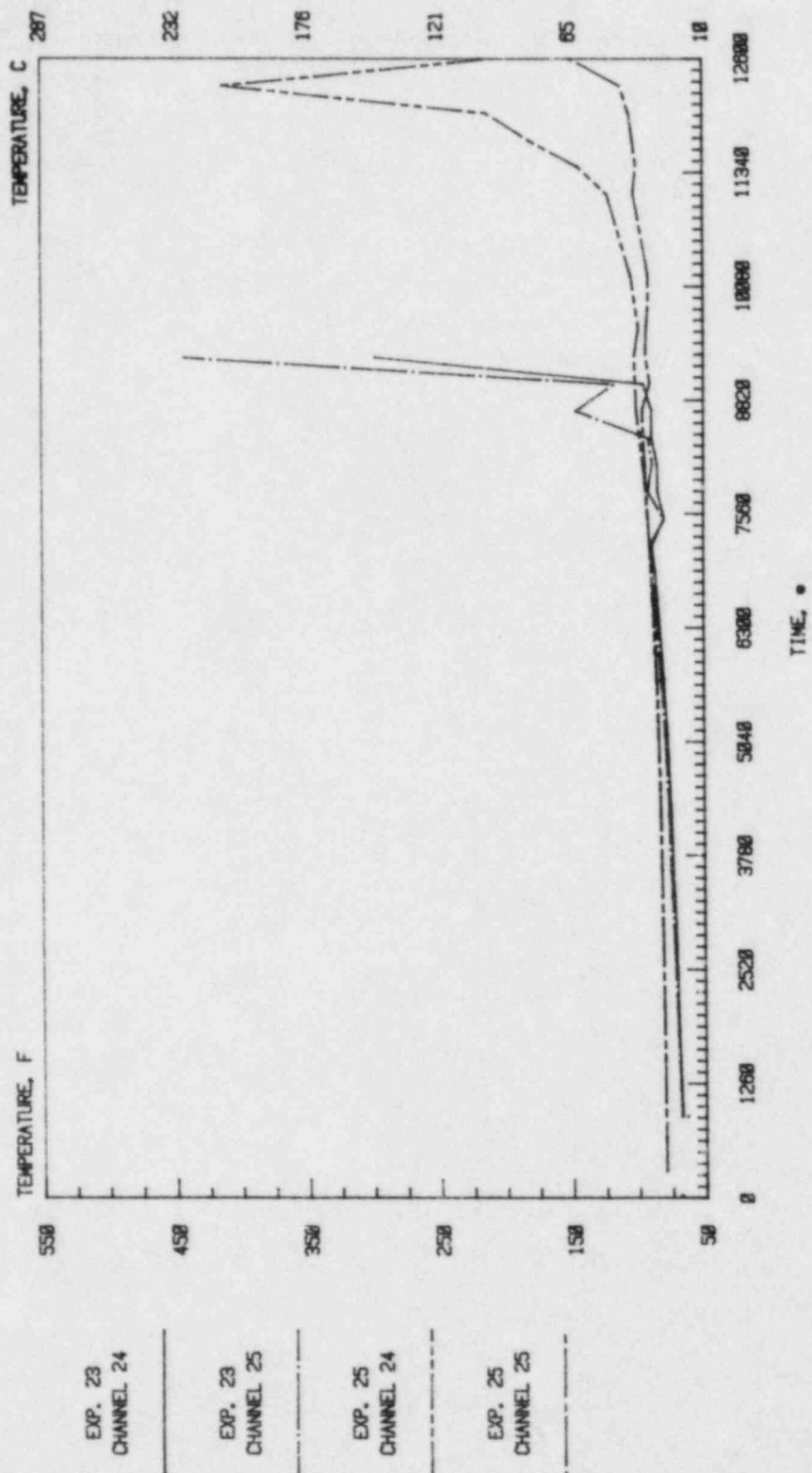

Figure 10 - Unexposed surface Temperatures; Exps. 23 and 25

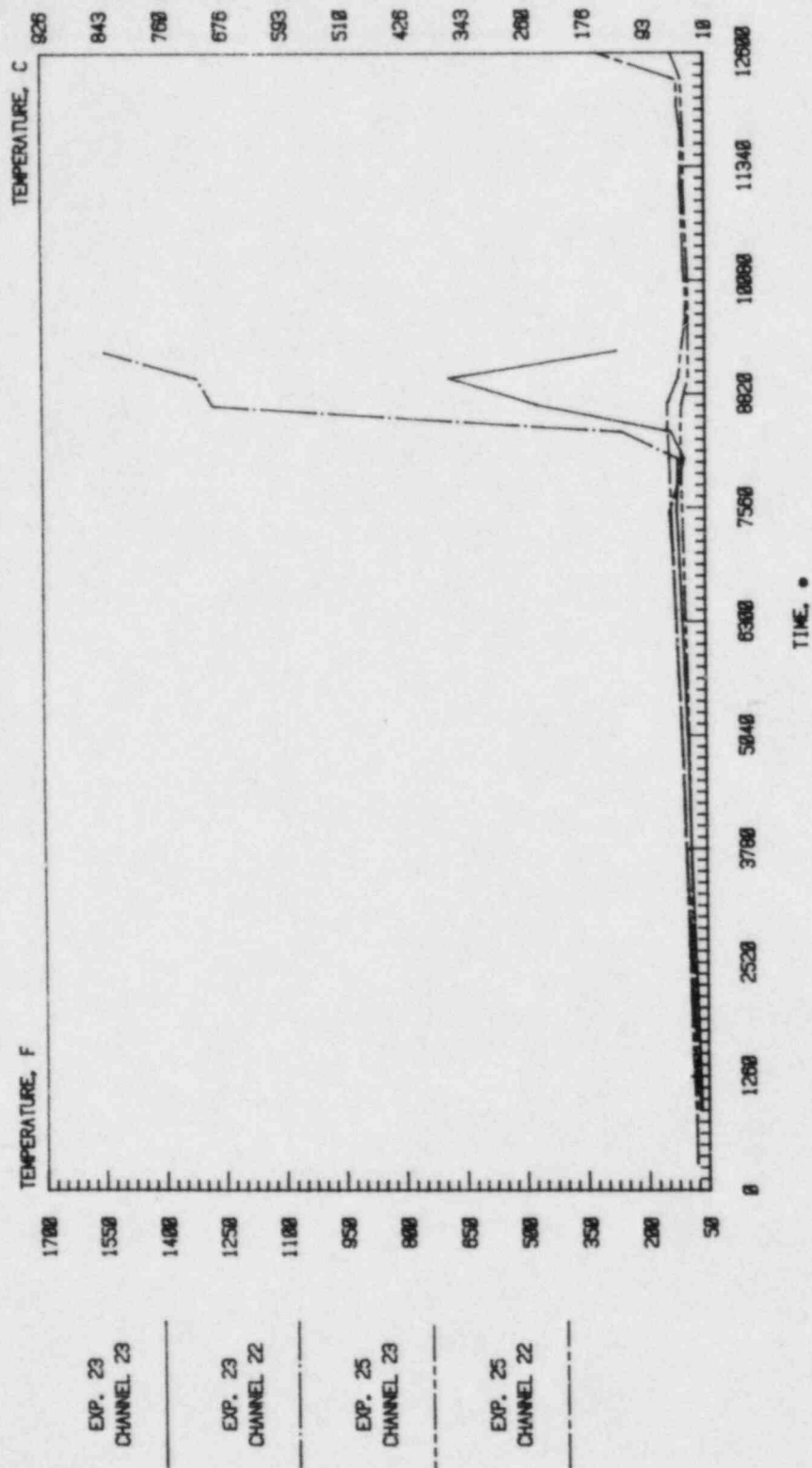

Figure 11 - Unexposed Surface Temperatures; Exps. 23 and 25

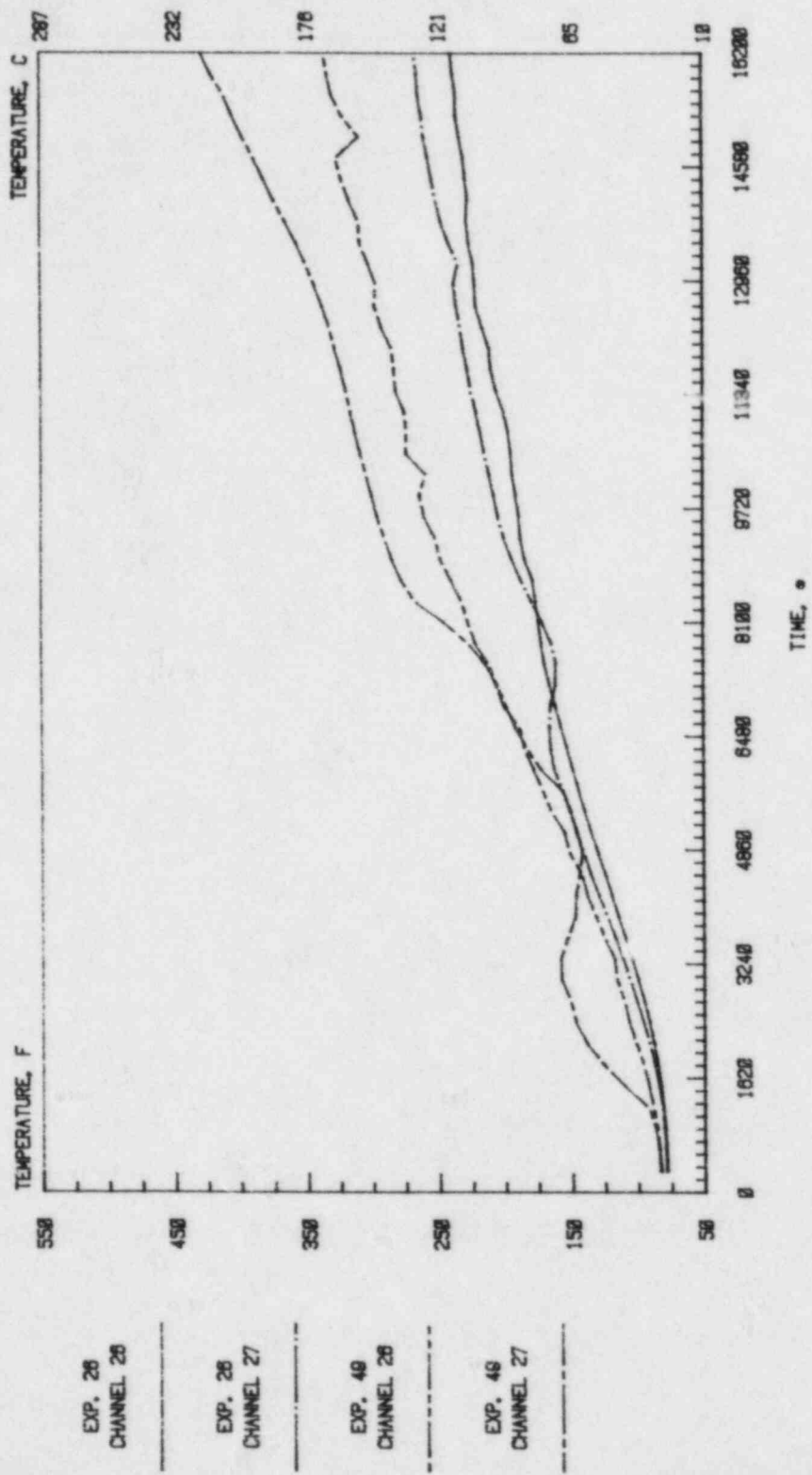

Figure 12 - Unexposed Surface Temperatures; Exps. 26 and 49

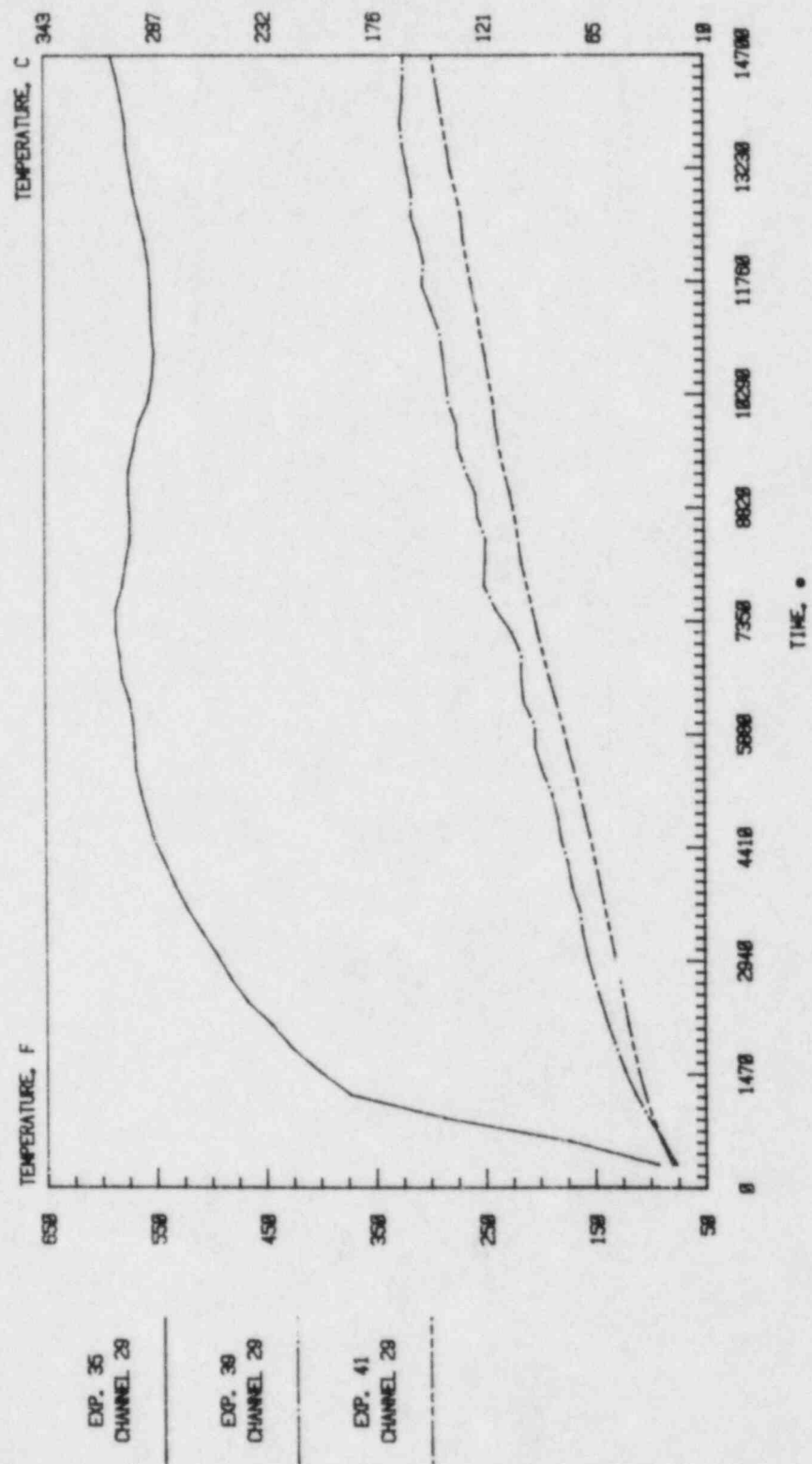

Figure 13 - Unexposed Surface Temperatures; Exps. 35, 39 and 41

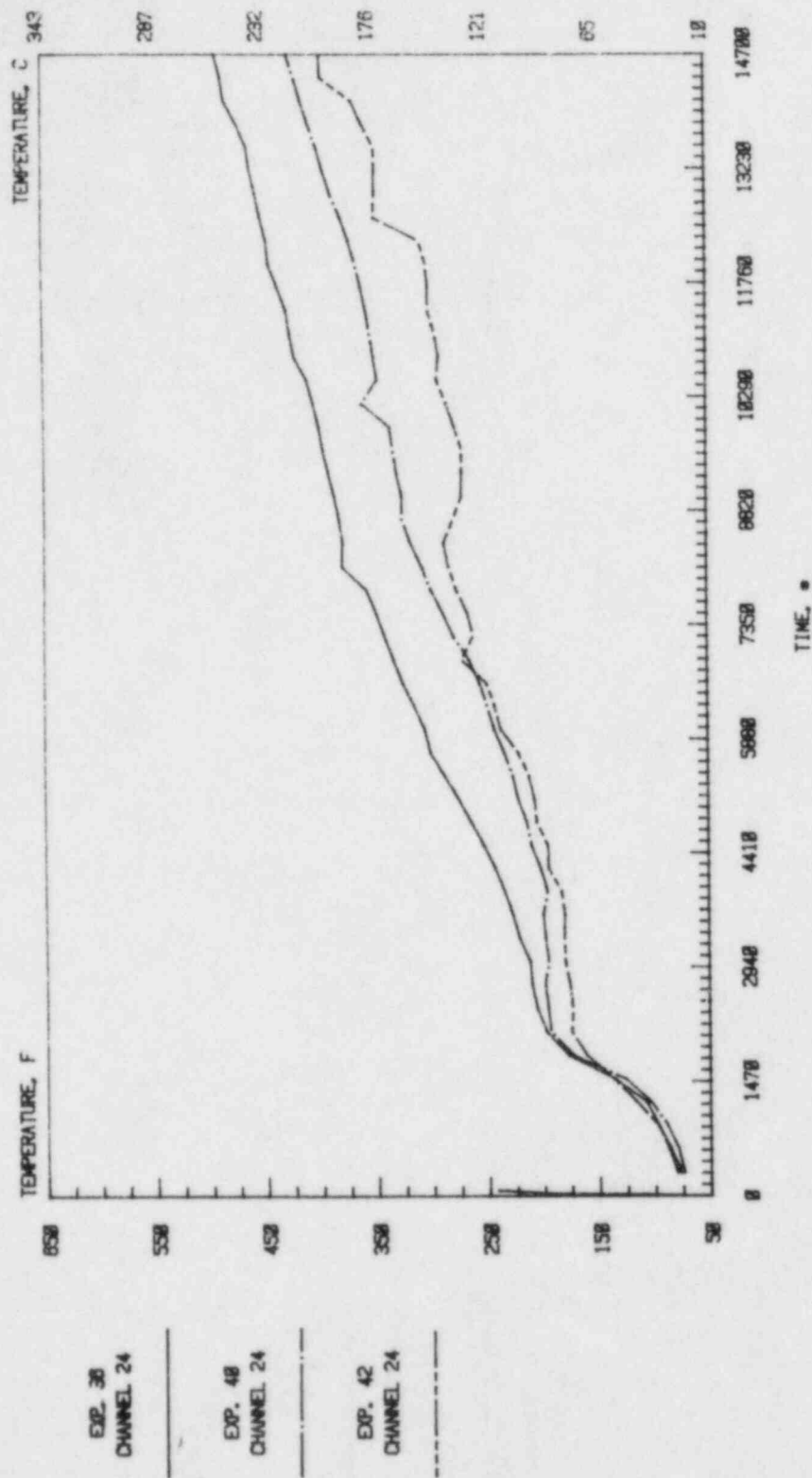

Figure 14 - Unexposed Surface Temperatures; Exps. 38, 40 and 42

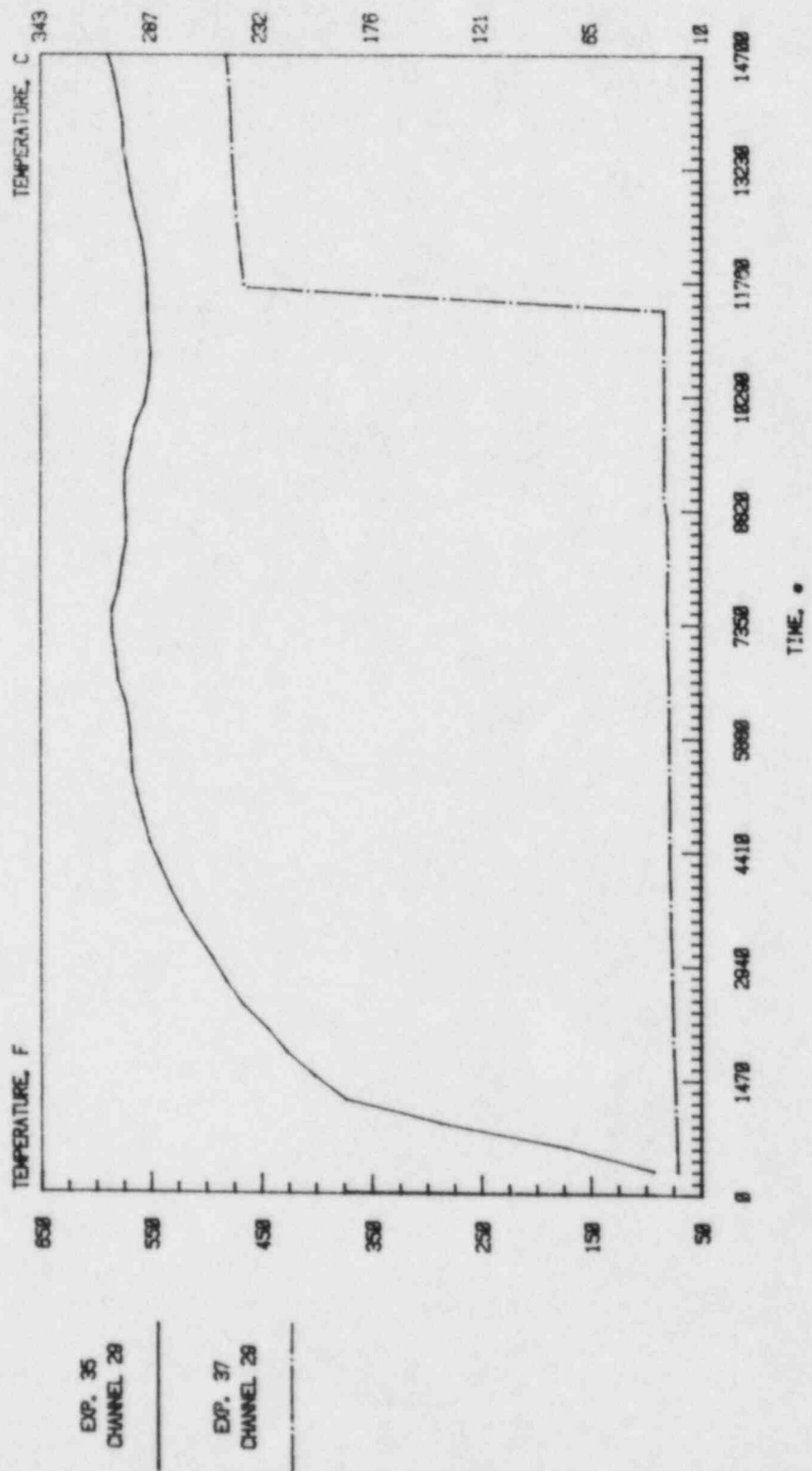

Figure 15 - Unexposed Surface Temperatures; Exps. 35 and 37

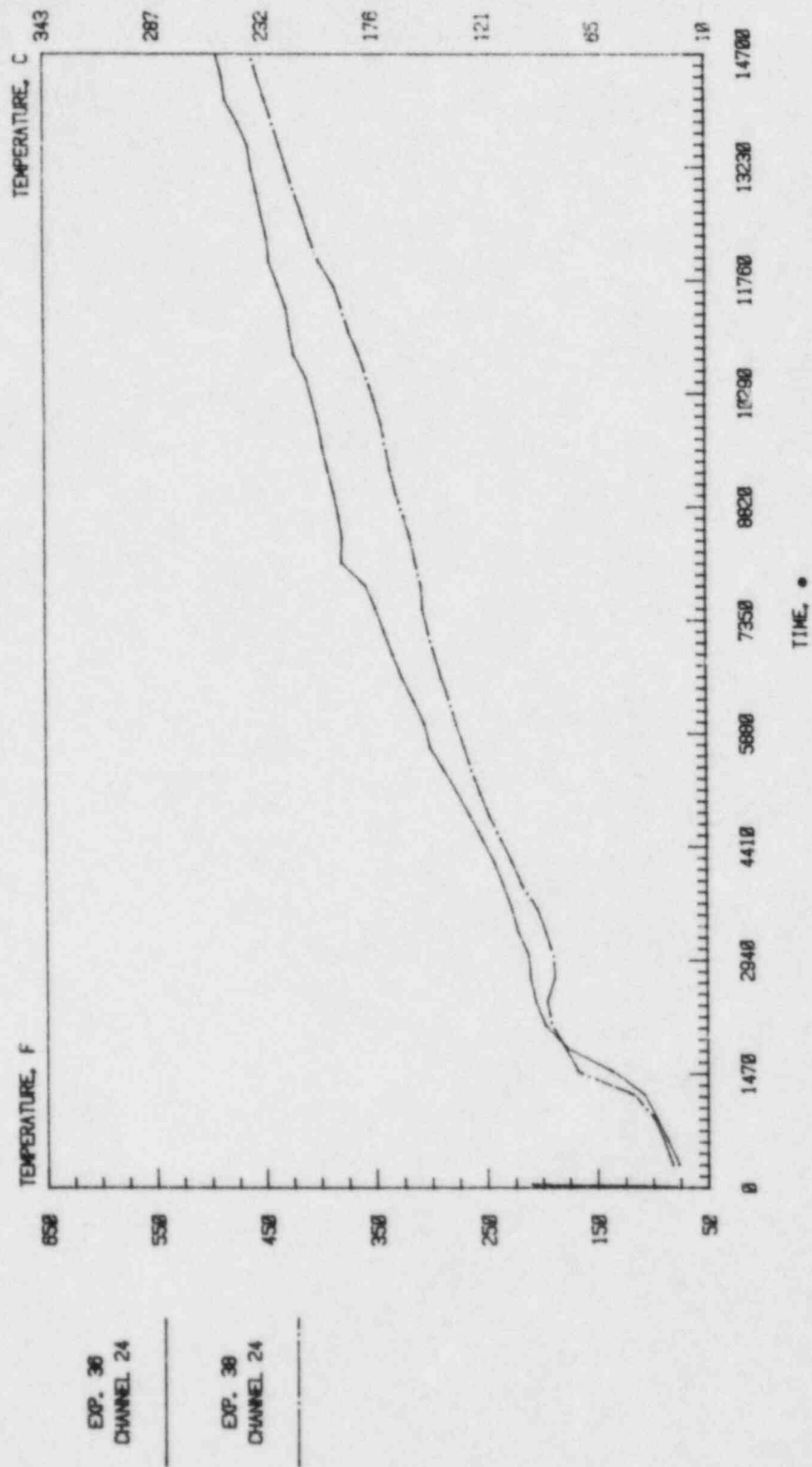

Figure 16 - Unexposed Surface Temperatures; Exps. 36 and 38

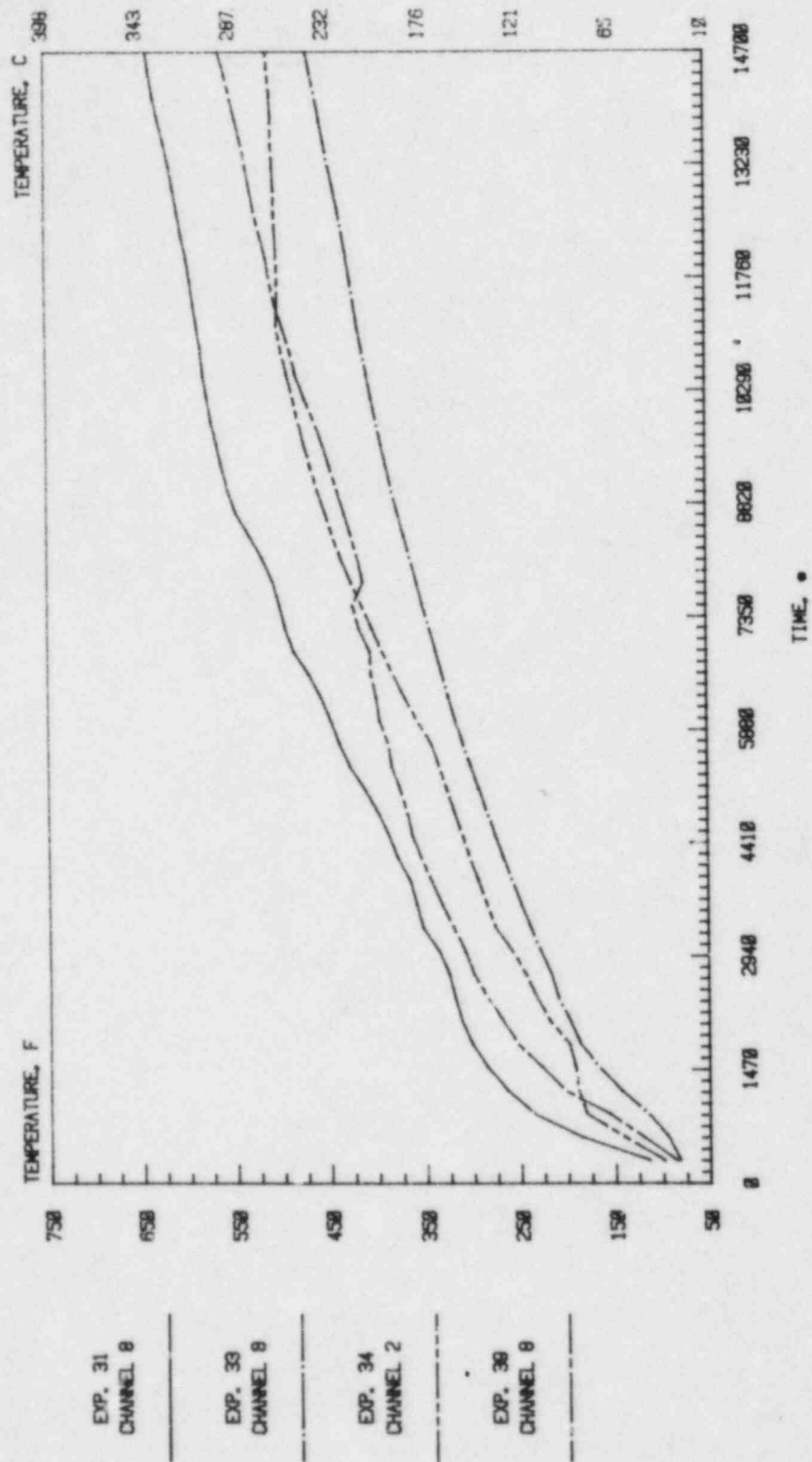

Figure 17 - Conductor Temperatures; Exps. 31, 33, 34 and 39

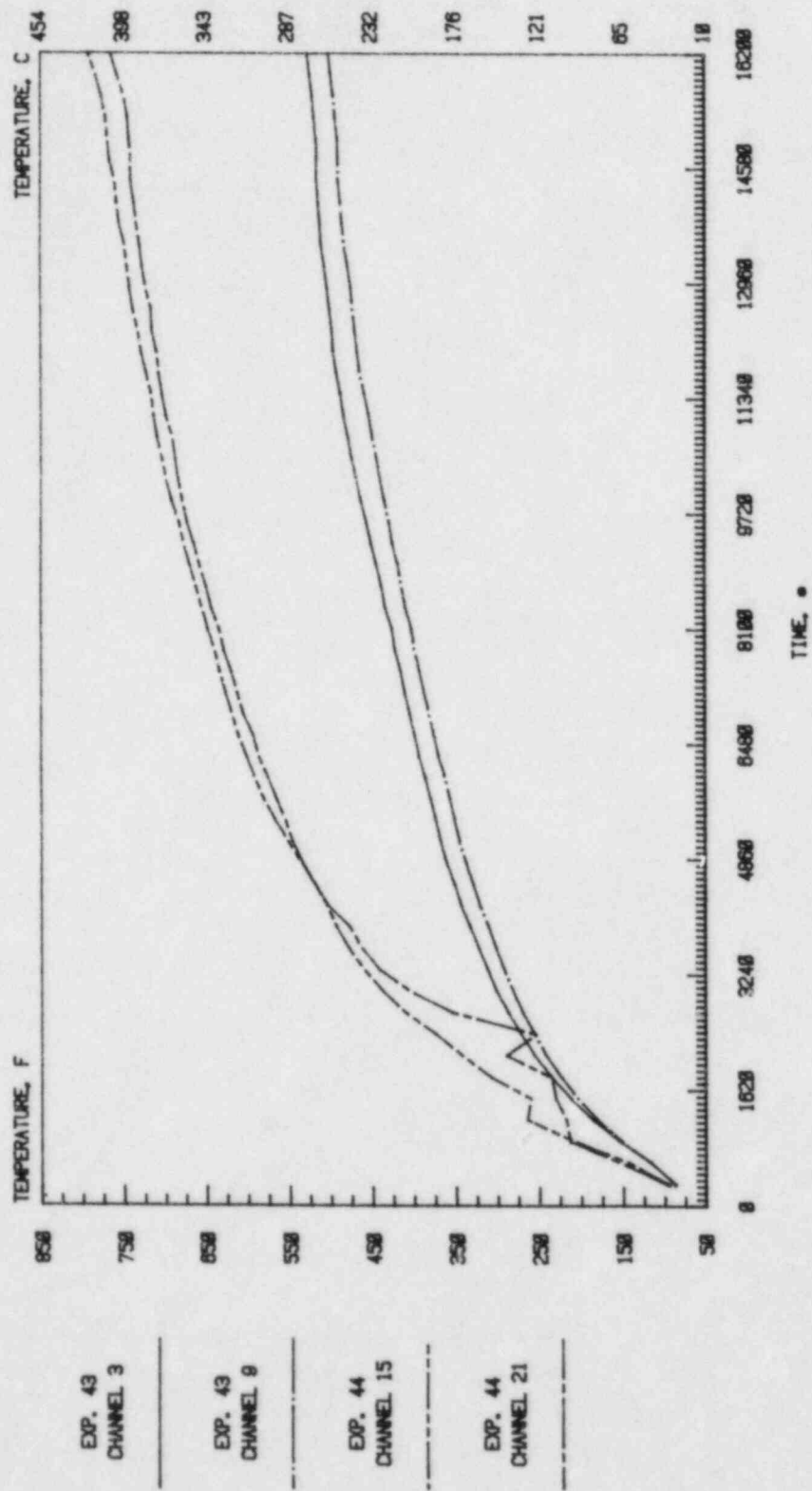

Figure 18 - Unexposed Surface Temperatures; Exps. 43 and 44

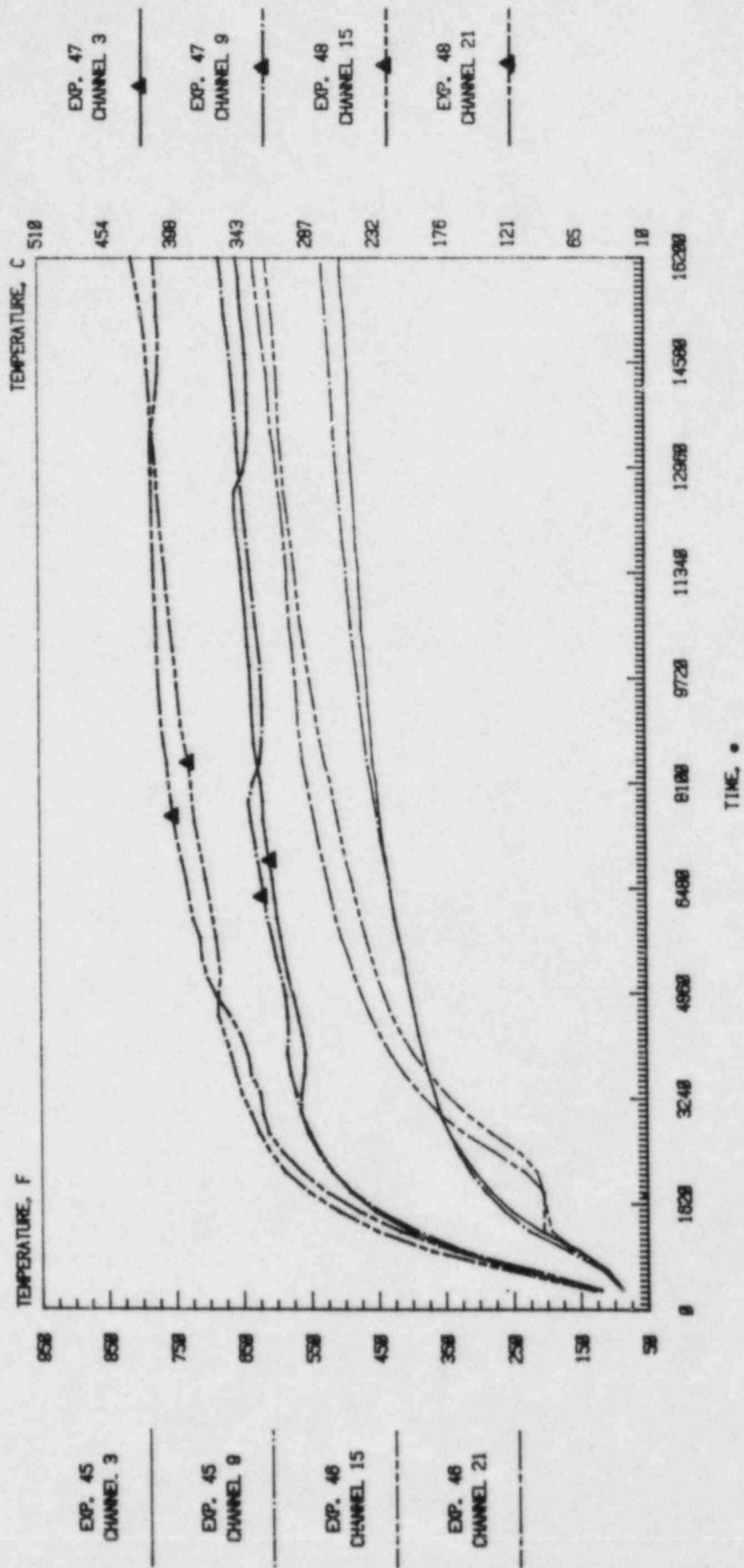
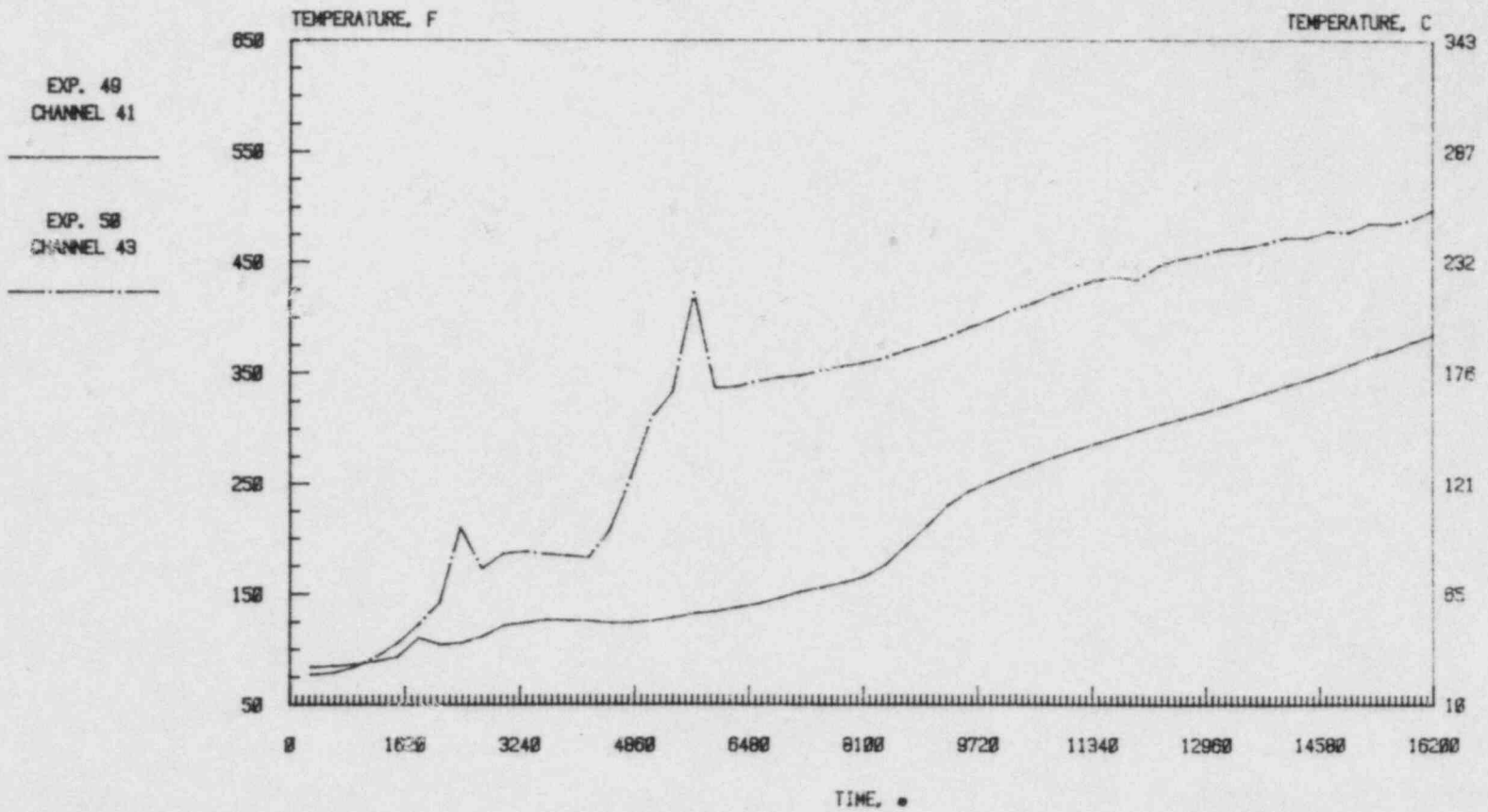

Figure 19 - Unexposed Surface Temperatures; Exps. 45, 46, 47 and 48

Figure 20 - Unexposed Surface Temperatures; Exps. 49 and 50



U.S. NUCLEAR REGULATORY COMMISSION
BIBLIOGRAPHIC DATA SHEET

1. REPORT NUMBER (Assigned by DDC)
NUREG/CR-4112, Vol. 2
US 75-2

4. TITLE AND SUBTITLE (Add Volume No., if appropriate)
Investigation of Cable and Cable System Fire
Test Parameters
Task B: Firestop Test Method

2. (Leave blank)

3. RECIPIENT'S ACCESSION NO.

7. AUTHOR(S)

5. DATE REPORT COMPLETED

MONTH | YEAR
December | 1984

9. PERFORMING ORGANIZATION NAME AND MAILING ADDRESS (Include Zip Code)

Underwriters Laboratories Inc.
333 Pfingsten Rd.
Northbrook, IL 60062

DATE REPORT ISSUED

MONTH | YEAR
January | 1985

6. (Leave blank)

8. (Leave blank)

12. SPONSORING ORGANIZATION NAME AND MAILING ADDRESS (Include Zip Code)

Division of Engineering Technology
Office of Nuclear Regulatory Research
U.S. Nuclear Regulatory Commission
Washington, DC 20555

10. PROJECT/TASK/WORK UNIT NO.

11. FIN NO.

B6197

13. TYPE OF REPORT

Final

PERIOD COVERED (Inclusive dates)

15. SUPPLEMENTARY NOTES

14. (Leave blank)

16. ABSTRACT (200 words or less)

An experimental investigation was conducted to provide data concerning the effects that changes in pressure differential, fire exposure and sample construction have on firestop performance when exposed to a standard fire test. Fifty-one fire test experiments were conducted using pressure differentials between -12 to +120 Pa, different sample constructions and two fire exposure conditions. Findings were that small changes in pressure differential did not have a significant effect on firestop materials that did not have cracks or through openings to allow passage of gases during fire exposure. If the materials allowed passage for gases through cracks or holes, such as those left open after pulling a cable, changing the pressure differential affected the firestop performance. Also, it was demonstrated that changing the size of the opening; size, location and type of the penetrating items installed through the opening; and severity of fire exposure affected the performance of the firestop.

17. KEY WORDS AND DOCUMENT ANALYSIS

17a DESCRIPTORS

Firestops, Penetrating Items, Pressure Differential, Fire Exposure Conditions, Sample Construction, Temperatures

17b. IDENTIFIERS/OPEN-ENDED TERMS

18. AVAILABILITY STATEMENT

Unlimited

19. SECURITY CLASS (This report)

UNCL

21. NO. OF PAGES

20. SECURITY CLASS (This page)

UNCL

22. PRICE
S

UNITED STATES
NUCLEAR REGULATORY COMMISSION
WASHINGTON, D.C. 20555

OFFICIAL BUSINESS
PENALTY FOR PRIVATE USE, \$300

FOURTH CLASS MAIL
POSTAGE & FEES PAID
USNRC
WASH. D.C.
PERMIT No. G-67