

DUQUESNE LIGHT COMPANY

Beaver Valley Power Station

Unit 1

INSERVICE TESTING (IST) PROGRAM FOR PUMP AND VALVES

Issue 2

Revision 8

<i>Ch. B. Baker for KLO</i> 3-11-92 Unit Operations Manager Review/Date	Pages Issued <i>i-iv</i> <i>1-180</i>	OSC Review Date <i>BU-OSC-</i> <i>10-92</i> <i>3/12/92</i>	Effective Date <i>3/13/92</i>
<i>[Signature]</i> Approved by	<i>3/12/92</i> Date		

List of Effective Pages

Page	Revision	Page	Revision
i	8	40	8
ii	8	41	8
iii	8	42	8
iv	8	43	8
1	8	44	8
2	8	45	8
3	8	46	8
4	8	47	8
5	8	48	8
6	8	49	8
7	8	50	8
8	8	51	8
9	8	52	8
10	8	53	8
11	8	54	8
12	8	55	8
13	8	56	8
14	8	57	8
15	8	58	8
16	8	59	8
17	8	60	8
18	8	61	8
19	8	62	8
20	8	63	8
21	8	64	8
22	8	65	8
23	8	66	8
24	8	67	8
25	8	68	8
26	8	69	8
27	8	70	8
28	8	71	8
29	8	72	8
30	8	73	8
31	8	74	8
32	8	75	8
33	8	76	8
34	8	77	8
35	8	78	8
36	8	79	8
37	8	80	8
38	8	81	8
39	8	82	8

INSERVICE TESTING (IST) PROGRAM FOR PUMPS AND VALVES

List of Effective Pages (Continued)

Page	Revision	Page	Revision
83	8	126	8
84	8	127	8
85	8	128	8
86	8	129	8
87	8	130	8
88	8	131	8
89	8	132	8
90	8	133	8
91	8	134	8
92	8	135	8
93	8	136	8
94	8	137	8
95	8	138	8
96	8	139	8
97	8	140	8
98	8	141	8
99	8	142	8
100	8	143	8
101	8	144	8
102	8	145	8
103	8	146	8
104	8	147	8
105	8	148	8
106	8	149	8
107	8	150	8
108	8	151	8
109	8	152	8
110	8	153	8
111	8	154	8
112	8	155	8
113	8	156	8
114	8	157	8
115	8	158	8
116	8	159	8
117	8	160	8
118	8	161	8
119	8	162	8
120	8	163	8
121	8	164	8
122	8	165	8
123	8	166	8
124	8	167	8
125	8	168	8

INSERVICE TESTING (IST) PROGRAM FOR PUMPS AND VALVES

List of Effective Pages (Continued)

Page	Revision	Page	Revision
169	8		
170	8		
171	8		
172	8		
173	8		
174	8		
175	8		
176	8		
177	8		
178	8		
179	8		
180	8		

INSERVICE TESTING (IST) PROGRAM FOR PUMPS AND VALVES

TABLE OF CONTENTS

SECTION I:	PUMP TESTING REQUIREMENTS	1
SECTION II:	PUMP TESTING OUTLINES	5
SECTION III:	PUMP TESTING RELIEF REQUESTS	38
SECTION IV:	VALVE TESTING REQUIREMENTS	47
SECTION V:	VALVE TESTING OUTLINES	54
SECTION VI:	VALVE TESTING COLD SHUTDOWN JUSTIFICATIONS	117
SECTION VII:	VALVE TESTING RELIEF REQUESTS	137

SECTION I: PUMP TESTING REQUIREMENTS

The Inservice Test (IST) Program for pumps at Beaver Valley Power Station (BVPS), Unit 1, is based on subsection IWP - Inservice Testing of Pumps of the ASME Boiler and Pressure Vessel Code, Section XI, 1983 edition through the summer 1983 addenda (the code) and Generic Letter 89-04, "Guidance on Developing Acceptable Inservice Testing Programs". The pumps included in this program are all ASME "class 1, 2, or 3 centrifugal or displacement type pumps that are required to perform a specific function in shutting down the reactor or in mitigating the consequences of an accident, and that are provided with an emergency power source" at BVPS, Unit 1.

The requirements of the code will be followed at all times unless specific relief has been granted by the NRC. An inservice test, run quarterly, to measure or observe the test quantities listed in Table IWP-3100-1, below, is required for all pumps in the IST Program by the code.

Table IWP-3100-1
INSERVICE TEST QUANTITIES

Quantity	Measure	Observe
Speed N (if variable speed)	✓	
Inlet pressure P_i	✓ (1)	
Differential pressure ΔP	✓	
Flow rate Q	✓	
Vibration amplitude V	✓	
Proper lubricant level or pressure		✓
Bearing temperature T_b	✓	

NOTE:
(1) Measure before pump startup and during test.

Table IWP-3100-2 shows the allowable ranges for test results that will be used to determine if corrective action is required following performance of BVPS-1 Surveillance Tests. The test data will be compared to the ranges applied to the reference values for each parameter. If these ranges cannot be met, reduced range limits that allow the pump to fulfill its function will be used in lieu of the ranges given in Table IWP-3100-2.

Table IWP-3100-2
ALLOWABLE RANGES OF TEST QUANTITIES

Test Quantity	Acceptable Range	Alert Range [Note (1)]		Required Action Range [Note (1)]	
		Low Values	High Values	Low Values	High Values
P_i	[Note (2)]	[Note (2)]	[Note (2)]	[Note (2)]	[Note (2)]
ΔP	$0.93-1.02\Delta P_r$	$0.90-0.93\Delta P_r$	$1.02-1.03\Delta P_r$	$<0.90\Delta P_r$	$>1.03\Delta P_r$
Q	$0.94-1.02Q_r$	$0.90-0.94Q_r$	$1.02-1.03Q_r$	$<0.90Q_r$	$>1.03Q_r$
V when $0 \leq V_r \leq 0.5$ mils	0-1 mil	None	1-1.5 mils	None	>1.5 mils
V when $0.5 \text{ mils} < V_r \leq 2.0$ mils	0-2V,mils	None	$2V_r - 1.5$ mils	None	$>3V_r$ mils
V when $2.0 \text{ mils} < V_r \leq 5.0$ mils	$0-(2 + V_r)$ mils	None	$(2 + V_r) - (4 + V_r)$ mils	None	$>(4 + V_r)$ mils
V when $V_r > 5.0$ mils	0-1.4V,mils	None	$1.4V_r - 1.8V_r$ mils	None	$>1.8V_r$ mils
T_b	[Note (3)]	[Note (3)]	[Note (3)]	[Note (3)]	[Note (3)]

NOTES:
(1) See IWP-3230.
(2) P_i shall be within the limits specified by Owner in the record of tests (IWP-6000).
(3) T_b shall be within the limits specified by Owner in the record of tests (IWP-6000).

Corrective action shall be taken if necessary using the following:

1. If deviations fall within the "Alert Range" of Table IWP-3100-2, the frequency of testing shall be doubled until the cause of the deviation is determined and corrected and either the existing reference values reverified or a new set established.
2. If the deviations fall within the "Required Action Range" of Table IWP-3100-2, the pump shall be declared inoperative immediately and an evaluation of the pump's condition with respect to system operability and technical specifications shall be made as follows:
 - a. If the inoperative pump is specifically identified in the technical specifications, then the applicable technical specification action statements must be followed.
 - b. If the inoperative pump is in a system covered by a technical specification, an assessment of its condition must be made to determine if it makes the system inoperative. If the condition of the pump renders the system inoperative, then the applicable system technical specification action statements must be followed.
 - c. Corrective action shall be either replacement or repair per IWP-3111, or shall be an analysis to demonstrate that the condition does not impair pump operability and that the pump will still fulfill its function. A new set of reference values shall be established after such analysis.
 - d. Nothing in the ASME Boiler and Pressure Vessel Code shall be construed to supercede the requirements of any technical specification.
3. When tests show deviations greater than allowed (see Table IWP-3100-2), the instruments involved may be recalibrated and the test rerun. This is an alternative to replacement or repair, not an additional action that can be taken before declaring the pump inoperative.
4. The pump shall not be returned to service until the condition has been corrected. The corrective action shall be considered completed when a satisfactory inservice test has been conducted in accordance with IWP-3111.

Per IWP-3500 each pump shall run at least 5 minutes under conditions as stable as the system permits prior to measurement of the specified parameters (when bearing temperature measurements are not required). When bearing temperature measurements are required, each pump shall be run until the bearing temperatures stabilize prior to making the specified measurements. A bearing temperature is considered stable when three successive readings taken at 10 minute intervals do not vary by more than 3%. Bearing temperature measurements are required annually (normally in August).

At certain times plant conditions may preclude returning a pump to the same reference condition for its normally scheduled surveillance. Since IWP-3112 permits the establishment of additional sets of reference values, a pump curve which is merely a graphical representation of these reference values will be used.

Records of the results of inservice tests and corrective actions as required by subsection IWP-6000 are trended in tabular form. Pump performance characteristics will be examined for trends.

The following two sections of this document are the "Pump Testing Outlines" and "Pump Relief Requests" sections. The "Pump Testing Outlines" section is a listing of all the pumps in the IST Program, their testing requirements, and their specific relief request reference numbers. The pumps are arranged according to system and pump mark number. The following abbreviations and designations are used on the Pump Testing Outlines and throughout the IST Program for pumps:

1. Under Parameter column
 - a. (N) - Speed
 - b. (Pi) - Inlet Pressure
 - c. (ΔP) - Differential Pressure
 - d. (Q) - Flowrate
 - e. (V) - Vibration
 - f. (Tb) - Bearing Temperature
 - g. (L) - Lubricant Level or Pressure
2. Under 1OST column
 - a. (1BVT) - Unit 1 Beaver Valley Test
 - b. (1OST) - Unit 1 Operating Surveillance Test
 - c. (Q) - Quarterly Test Frequency
 - d. (A) - Annual Test Frequency
 - e. (CSD) - Cold Shutdown Frequency
 - f. (R) - Refueling Test Frequency
 - g. (NA) - Not Applicable
3. Under Req'd column
 - a. (RR) - Relief Request
 - b. (X) - Meets or exceeds ASME requirements
 - c. (E) - Exempt
 - d. (NA) - Not Applicable

The "Pump Relief Requests" section contains the detailed technical description of particular conditions and equipment installations prohibiting the testing of some of the characteristics of safety-related pumps. An alternate test method and the frequency of revised testing is also included to meet the intent of 10CFR50.55a. The relief request(s) for a specific pump is referenced by the number(s) listed on the pump's testing outline sheet.

SECTION II: PUMP TESTING OUTLINES

BVPS-1 IST

PUMP TESTING OUTLINE

Pump Name: 1A, Charging Pump	Pump Number: 1CH-P-1A	Code Class: 2	Dwg. OM No.: 7-1 Dwg. Coord.: C-4	System: 7 Chemical and Volume Control
------------------------------	-----------------------	---------------	--------------------------------------	---------------------------------------

Function: To provide normal RCS inventory and Hi Head Safety Injection Type: Centrifugal Remarks: See RR1 and RR2

Parameter	1OST (Frequency)	Req'd	Comments
N	NA	NA	Constant speed induction motor.
Pi	7.4 (Q)	RR2	No installed instrumentation to measure suction pressure. Install temporary test gauge at pump suction (local) or calculate Pi using VCT level indicator [LI-1CH-115] and VCT pressure indicator [PI-1CH-117] or RWST level indicator [LI-1QS-100A], Control Room.
ΔP	7.4 (Q)	X	ΔP is calculated using the pump discharge pressure indicator [PI-1CH-151], local, and the calculated Pi, Control Room.
Q	7.4 (Q)	X	Summation of flow rates from RCP Seal Injection Flow Indicators [FI-1CH-130], [FI-1CH-127], and [FI-1CH-124] or Charging Flow Indicator [FI-1CH-122A], and RCS Loop Fill Flow Indicator [FI-1CH-160], Control Room, and assumed flow thru miniflow line.
V	7.4 (Q)	RR1	Portable monitoring equipment using velocity units.
Tb	NA	RR1	Annual pump bearing temperature measurements will not be taken since vibration is measured in velocity units.
L	7.4 (Q)	X	Lubricant oil filter pressure gauge [FI-1CH-161A1], local. Sightglass on oil reservoir, local.

BVPS-1 IST

PUMP TESTING OUTLINE

Pump Name: 1B Charging Pump		Pump Number: 1CH-P-1B	Code Class: 2	Dwg. OM No.: 7-1 Dwg. Coord.: D-4	System: 7 Chemical and Volume Control
Function: To provide normal RCS inventory and Hi Head Safety Injection			Type: Centrifugal	Remarks: See RR1 and RR2	
Parameter	1OST (Frequency)	Req'd	Comments		
N	NA	NA	Constant speed induction motor.		
Pi	7.5 (Q)	RR2	No installed instrumentation to measure suction pressure. Install temporary test gauge at pump suction (local) or calculate Pi using VCT level indicator [LI-1CH-115] and VCT pressure indicator [PI-1CH-117] or RWST level indicator [LI-1QS-100A]. Control Room.		
ΔP	7.5 (Q)	X	ΔP is calculated using the pump discharge pressure indicator [PI-1CH-152], local, and the calculated Pi, Control Room.		
Q	7.5 (Q)	X	Summation of flow rates from RCP Seal Injection Flow Indicators [FI-1CH-130], [FI-1CH-127], and [FI-1CH-124] or Charging Flow Indicator [FI-1CH-122A], and RCS Loop Fill Flow Indicator [FI-1CH-160], Control Room, and assumed flow thru miniflow line.		
V	7.5 (Q)	RR1	Portable monitoring equipment using velocity units.		
Tb	NA	RR1	Annual pump bearing temperature measurements will not be taken since vibration is measured in velocity units.		
L	7.5 (Q)	X	Lubricant oil filter pressure gauge [FI-1CH-161B1], local. Sightglass on oil reservoir, local.		

BVPS-1 IST

PUMP TESTING OUTLINE

Pump Name: 1C Charging Pump		Pump Number: 1CH-P-1C	Code Class:	Dwg. OM No.: 7-1 Dwg. Coord.: E-4	System: 7 Chemical and Volume Control
Function: To provide normal RCS inventory and Hi Head Safety Injection			Type: Centrifugal	Remarks: See RR1 and RR2	
Parameter	10ST (Frequency)	Req'd	Comments		
N	NA	NA	Constant speed induction motor.		
PI	7.6 (Q)	RR2	No installed instrumentation to measure suction pressure. Install temporary test gauge at pump suction (local) or calculate Pi using VCT level indicator [LI-1CH-115] and VCT pressure indicator [PI-1CH-117] or RWST level indicator [LI-1QS-100A], Control Room.		
ΔP	7.6 (Q)	X	ΔP is calculated using the pump discharge pressure indicator [PI-1CH-153], local, and the calculated Pi, Control Room.		
Q	7.6 (Q)	X	Summation of flow rates from RCP Seal Injection Flow Indicators [FI-1CH-130], [FI-1CH-127], and [FI-1CH-124] or Charging Flow Indicator [FI-1CH-122A], and RCS Loop Fill Flow Indicator [FI-1CH-160], Control Room, and assumed flow thru miniflow line.		
V	7.6 (Q)	RR1	Portable monitoring equipment using velocity units.		
Tb	NA	RR1	Annual pump bearing temperature measurements will not be taken since vibration is measured in velocity units.		
L	7.6 (Q)	X	Lubricant oil filler pressure gauge [FI-1CH-161C1], local. Sightglass on oil reservoir, local.		

BVPS-1 IST

PUMP TESTING OUTLINE

Pump Name: 2A Boric Acid Transfer Pump	Pump Number: 1CH-P-2A	Code Class: 3	Dwg. OM No.: 7-3 Dwg. Coord.: C-3	System: 7 Chemical and Volume Control
Function: Chemical Shim and Emergency Boration Supply		Type: Centrifugal	Remarks: See RR1, RR2 and RR3	

Parameter	ICST (Frequency)	Req'd	Comments
N	NA	NA	Constant speed induction motor.
Pi	7.1 (Q)	RR2	No installed instrumentation to measure suction pressure. Calculate Pi from the level in the Boric Acid Storage Tank, [LI-1CH-106(161)], Control Room.
	7.13 (R)	RR2	No installed instrumentation to measure suction pressure. Calculate Pi from the level in the Boric Acid Storage Tank, [LI-1CH-106(161)], Control Room.
ΔP	7.1 (Q)	X	ΔP is calculated using the pump discharge pressure indicator [PI-1CH-110], local, and the calculated Pi, Control Room.
	7.13 (R)	X	ΔP is calculated using the pump discharge pressure indicator [PI-1CH-110], local, and the calculated Pi, Control Room.
Q	7.1 (Q)	RR3	No installed instrumentation to measure flow rate quarterly.
	7.13 (R)	X	Flow rate measurement by tank level change over time performed at refuelings.
V	7.1 (Q)	RR1	Portable monitoring equipment using velocity units.
	7.13 (R)	RR1	Portable monitoring equipment using velocity units.
Tb	NA	RR1	Annual pump bearing temperature measurements will not be taken since vibration is measured in velocity units.
L	7.1 (Q)	X	Bearing housing provided with sightglass at oil level reservoir, local.
	7.13 (R)	X	Bearing housing provided with sightglass at oil level reservoir, local.

BVPS-1 IST

PUMP TESTING OUTLINE

Pump Name: 2B Boric Acid Transfer Pump	Pump Number: 1CH-P-2B	Code Class: 3	Dwg. OM No.: 7-3 Dwg. Coord.: G-3	System: 7 Chemical and Volume Control
Function: Chemical Shim and Emergency Boration Supply		Type: Centrifugal	Remarks: See RR1, RR2 and RR3	

Parameter	10ST (Frequency)	Req'd	Comments
N	NA	NA	Constant speed induction motor.
Pi	7.2 (Q)	RR2	No installed instrumentation to measure suction pressure. Calculate Pi from the level in the Boric Acid Storage Tank, [LI-1CH-106(161)], Control Room.
	7.14 (R)	RR2	No installed instrumentation to measure suction pressure. Calculate Pi from the level in the Boric Acid Storage Tank, [LI-1CH-106(161)], Control Room.
ΔP	7.2 (Q)	X	ΔP is calculated using the pump discharge pressure indicator [PI-1CH-105A], local, and the calculated Pi, Control Room.
	7.14 (R)	X	ΔP is calculated using the pump discharge pressure indicator [PI-1CH-105A], local, and the calculated Pi, Control Room.
Q	7.2 (Q)	RR3	No installed instrumentation to measure flow rate quarterly.
	7.14 (R)	X	Flow rate measurement by tank level change over time performed at refuelings.
V	7.2 (Q)	RR1	Portable monitoring equipment using velocity units.
	7.14 (R)	RR1	Portable monitoring equipment using velocity units.
Tb	NA	RR1	Annual pump bearing temperature measurements will not be taken since vibration is measured in velocity units.
L	7.2 (Q)	X	Bearing housing provided with sightglass at oil level reservoir, local.
	7.14 (R)	X	Bearing housing provided with sightglass at oil level reservoir, local.

BVPS-1 IST

PUMP TESTING OUTLINE

Pump Name: 1A Residual Heat Removal Pump		Pump Number: 1RH-P-1A	Code Class: 2	Dwg. OM No.: 10-1 Dwg. Coord.: E-3	System: 10 Residual Heat Removal
Function: Long Term Decay Heat Removal			Type: Vertical	Remarks: See RR4. Pump is tested quarterly during cold shutdowns and refueling outages.	
Parameter	10ST (Frequency)	Req'd	Comments		
N	NA	NA	Constant speed induction motor.		
PI	10.1 (CSD,R)	X	No permanently installed suction pressure gauge, temporary test gauge installed on [1RH-200] for test, local.		
ΔP	10.1 (CSD,R)	X	Calculated using pump discharge pressure indicator [PI-1RH-600], local, and pump suction pressure (local) or from temporary ΔP gauge installed between [1RH-200] and [1RH-213], local.		
Q	10.1 (CSD,R)	X	Flow indicator [FI-1RH-605], Control Room.		
V	10.1 (CSD,R)	X	Portable monitoring equipment.		
Tb	10.1 (A)	X	Pump bearings in driver. Portable monitoring equipment required (i.e., contact pyrometer) or Control Room computer address points for thermocouples provided for bearings. Motor Inboard bearing (T0686A), Motor Outboard bearing (T0687A).		
L	NA	NA	No lubricant level or pressure to observe. Lubrication is by the fluid being pumped.		

BVPS-1 IST

PUMP TESTING OUTLINE

Pump Name: 1B Residual Heat Removal Pump		Pump Number: 1RH-P-1B	Code Class: 2	Dwg. OM No.: 10-1 Dwg. Coord.: F-3	System: 10 Residual Heat Removal
Function: Long Term Decay Heat Removal			Type: Vertical	Remarks: See RR4. Pump is tested quarterly during cold shutdowns and refueling outages.	
Parameter	10ST (Frequency)	Req'd	Comments		
N	NA	NA	Constant speed induction motor.		
Pi	10.1 (CSD,R)	X	No permanently installed suction pressure gauge, temporary test gauge installed on [1RH-200] for test, local		
ΔP	10.1 (CSD,R)	X	Calculated using pump discharge pressure indicator [PI-1RH-601], local, and pump suction pressure (local) or from temporary ΔP gauge installed between [1RH-200] and [1RH-213], local.		
Q	10.1 (CSD,R)	X	Flow indicator [FI-1RH-605], Control Room.		
V	10.1 (CSD,R)	X	Portable monitoring equipment.		
Tb	10.1 (A)	X	Pump bearings in driver. Portable monitoring equipment required (i.e., contact pyrometer) or Control Room computer address points for thermocouples provided for bearings. Motor Inboard bearing (T0696A), Motor Outboard bearing (T0697A).		
L	NA	NA	No lubricant level or pressure to observe. Lubrication is by the fluid being pumped.		

Beaver Valley Power Station
 Unit 1
 INSERVICE TESTING (IST) PROGRAM FOR PUMPS AND VALVES
 Issue 2
 Revision 8
 Page 12 of 180

BVPS-1 IST

PUMP TESTING OUTLINE

Pump Name: 1A Low Head Safety Injection Pump		Pump Number: 1SI-P-1A	Code Class: 2	Dwg. OM No.: 11-1 Dwg. Coord.: F-2	System: 11 Safety Injection
Function: Low Pressure - High Volume Safety Injection and Long Term Recirculation			Type: Vertical	Remarks: Sec RR2. Pump is tested quarterly on recirculation flow and at full flow during refueling outages.	
Parameter	10ST (Frequency)	Req'd	Comments		
N	NA	NA	Constant speed induction motor.		
Pi	11.1 (Q)	RR2	No installed instrumentation to measure suction pressure. Calculate Pi using RWST level indicators [LI-1QS-100A-D], Control Room.		
	11.14 (R)	RR2	No installed instrumentation to measure suction pressure. Calculate Pi using RWST level indicators [LI-1QS-100A-D], Control Room.		
ΔP	11.1 (Q)	X	ΔP is calculated using the pump discharge pressure indicator [PI-1SI-943], local, and the calculated Pi, Control Room.		
	11.14 (R)	X	ΔP is calculated using the pump discharge pressure indicator [PI-1SI-943], local, and the calculated Pi, Control Room.		
Q	11.1 (Q)	X	Flow indicator [FI-1SI-941], local. (Mini flow and test line flow indicator).		
	11.14 (R)	X	Flow indicator [FI-1SI-941], local and [FI-1SI-945], Control Room.		
V	11.1 (Q)	X	Portable monitoring equipment - Fixed vibration probes on pump shaft.		
	11.14 (R)	X	Portable monitoring equipment - Fixed vibration probes on pump shaft.		
Tb	11.1 (A)	X	Control Room computer address points for thermocouple provided for pump bearings. Top pump bearing (T0911A).		
	NA	NA	Not required during refueling test. Bearing temperatures are obtained in quarterly test annually.		
L	NA	NA	No lubricant level or pressure to observe. Lubrication is by the fluid being pumped.		

BVPS-1 IST

PUMP TESTING OUTLINE

Pump Name: 1B Low Head Safety Injection Pump		Pump Number: 1SI-P-1B	Code Class: 2	Dwg. OM No.: 11-1 Dwg. Coord.: F-4	System: 11 Safety Injection
Function: Low Pressure - High Volume Safety Injection and Long Term Recirculation			Type: Vertical	Remarks: See RR2. Pump is tested quarterly on recirculation flow and at full flow during refueling outages.	
Parameter	10ST (Frequency)	Req'd	Comments		
N	NA	NA	Constant speed induction motor.		
Pi	11.2 (Q)	RR2	No installed instrumentation to measure suction pressure. Calculate Pi using RWST level indicators [LI-1QS-100-D], Control Room.		
	11.14 (R)	RR2	No installed instrumentation to measure suction pressure. Calculate Pi using RWST level indicators [LI-1QS-100A-D], Control Room.		
ΔP	11.2 (Q)	X	ΔP is calculated using the pump discharge pressure indicator [PI-1SI-944], local, and the calculated Pi, Control Room.		
	11.14 (R)	X	ΔP is calculated using the pump discharge pressure indicator [PI-1SI-944], local, and the calculated Pi, Control Room.		
Q	11.2 (Q)	X	Flow indicator [FI-1SI-941], local. (Mini flow and test line flow indicator).		
	11.14 (R)	X	Flow indicator [FI-1SI-941], local and [FI-1SI-946], Control Room.		
V	11.2 (Q)	X	Portable monitoring equipment - Fixed vibration probes on pump shaft.		
	11.14 (R)	X	Portable monitoring equipment - Fixed vibration probes on pump shaft.		
Tb	11.2 (A)	X	Control Room computer address points for thermocouple provided for pump bearings. Top pump bearing (T0921A).		
	11.14 (A)	NA	Not required during refueling test. Bearing temperatures are obtained in quarterly test annually.		
L	NA	NA	No lubricant level or pressure to observe. Lubrication is by the fluid being pumped.		

BVPS-1 IST

PUMP TESTING OUTLINE

Pump Name: 1A Quench Spray Pump	Pump Number: 1QS-P-1A	Code Class: 2	Dwg. OM No.: 13-1 Dwg. Coord.: D-5	System: 13 Containment Depressurization
---------------------------------	-----------------------	---------------	---------------------------------------	---

Function: To provide a flow of borated water for containment depressurization following a DBA. Type: Centrifugal. Remarks: See RR1 and RR2.

Parameter	10ST (Frequency)	Req'd	Comments
N	NA	NA	Constant speed induction motor.
Pi	13.1 (Q)	RR2	No installed instrumentation to measure suction pressure. Install temporary test gauge at pump suction (local) or calculate Pi using RWST level indicator [LI-1QS-100A-D], Control Room.
ΔP	13.1 (Q)	X	ΔP is calculated using the pump discharge pressure indicator [PI-1QS-101A], local, and the calculated Pi, Control Room.
Q	13.1 (Q)	X	Total flow calculated by summing flow rates from spray line flow indicator [FI-1QS-104] and recirculation line flow indicator [FI-1QS-103], local.
V	13.1 (Q)	RR1	Portable monitoring equipment using velocity units.
Tb	NA	RR1	Annual pump bearing temperature measurements will not be taken since vibration is measured in velocity units.
L	13.1 (Q)	X	Level indication provided at constant level oilers (local) on each bearing housing.

BVPS-1 IST

PUMP TESTING OUTLINE

Pump Name: 1B Quench Spray Pump	Pump Number: 1QS-P-1B	Code Class: 2	Dwg. OM No.: 13-1 Dwg. Coord.: D-6	System: 13 Containment Depressurization
---------------------------------	-----------------------	---------------	---------------------------------------	---

Function: To provide a flow of borated water for containment depressurization following a DBA. Type: Centrifugal Remarks: See RR1 and RR2

Parameter	10ST (Frequency)	Req'd	Comments
N	NA	NA	Constant speed induction motor.
Pi	13.2 (Q)	RR2	No installed instrumentation to measure suction pressure. Install temporary test gauge at pump suction (local) or calculate Pi using RWST level indicator [LI-1QS-100A-D], Control Room.
ΔP	13.2 (Q)	X	ΔP is calculated using the pump discharge pressure indicator [PI-1QS-101B], local, and the calculated Pi, Control Room.
Q	13.2 (Q)	X	Total flow calculated by summing flow rates from spray line flow indicator [FI-1QS-104] and recirculation line flow indicator [FI-1QS-103], local.
V	13.2 (Q)	RR1	Portable monitoring equipment using velocity units.
Tb	NA	RR1	Annual pump bearing temperature measurements will not be taken since vibration is measured in velocity units.
L	13.2 (Q)	X	Level indication provided at constant level oilers (local) on each bearing housing.

BVPS-1 IST

PUMP TESTING OUTLINE

Pump Name: 4A Chemical Injection Pump		Pump Number: 1QS-P-4A	Code Class: 2	Dwg. OM No.: 13-1 Dwg. Coord.: F-10	System: 13 Containment Depressurization
Function: Chemical Injection during Containment Depressurization.			Type: Positive Displacement	Remarks: See RR1 and RR5.	
Parameter	1QST (Frequency)	Req'd	Comments		
N	NA	NA	Constant speed induction motor.		
Pi	13.10A (Q)	RR5	Positive displacement pump. No suction pressure indication provided.		
ΔP	13.10A (Q)	RR5	Positive displacement pump. Based on pump discharge pressure indicator [PI-1QS-00A], local.		
Q	13.10A (Q)	X	Will check using recirculation line flow indicator [FI-1QS-108], local.		
V	13.10A (Q)		Portable monitoring equipment using velocity units.		
Tb	NA	RR1	Annual pump bearing temperature measurements will not be taken since vibration is measured in velocity units.		
L	NA	NA	No lubricant level or pressure to observe. Bearings are grease lubricated.		

BVPS-1 IST

PUMP TESTING OUTLINE

Pump Name: 4B Chemical Injection Pump	Pump Number: 1QS-108	Code Class: 2	Dwg. OM No.: 13-1 Dwg. Coord.: F-	System: 1. Containment Depressurization
--	-----------------------------	----------------------	--	--

Function: Chemical Injection during Containment Depressurization	Type: Positive Displacement	Remark: See RR1 and RR5
---	------------------------------------	--------------------------------

Parameter	10ST (Frequency)	Stand	Comments
N	NA	NA	Constant speed induction motor.
PI	13.10B (Q)	RR5	Positive displacement pump. No suction pressure indication provided.
ΔP	13.10B (Q)	RR5	Positive displacement pump. Based on pump discharge pressure indicator [PI-1QS-400B], local.
Q	13.10B (Q)	X	Will check using recirculation line flow indicator [FI-1QS-108], local.
V	13.10B (Q)	RR1	Portable monitoring equipment using velocity units.
Tb	NA	RR1	Annual pump bearing temperature measurements will not be taken since vibration is measured in velocity units.
L	NA	NA	No lubricant level or pressure to observe. Bearings are grease lubricated.

Beaver Valley Power Station Unit 1
 INSERVICE TESTING (IST) PROGRAM FOR PUMPS AND VALVES

INSERVICE TESTING (IST) PROGRAM FOR PUMPS AND VALVES

Pump Name: 4C Chemical Injection Pump		Pump Number: 10S-P-4C	Code Class: 2	Dwg. OM No.: 13-1	System: 13 Containment Depressurization
Function: Chemical Injection during Containment Depressurization.		Type: Positive Displacement	Remarks: See RR1 and RR5		
Parameter	10S* (Frequency)	Req'd	Comments		
N	NA	NA	Constant speed induction motor.		
PI	13 10A (Q)	RR5	Positive displacement pump No suction pressure indication provided		
ΔP	13 10A (Q)	RR5	Positive displacement pump Based on pump discharge pressure indicator [PI-10S-400A], local		
Q	13 10A (Q)	X	Will check using recirculation line flow indicator [FI-10S-108], local		
V	13 10A (Q)	RR1	Portable monitoring equipment using velocity units		
Tb	NA	RR1	Annual pump bearing temperature measurements will not be taken since vibration is measured in velocity units		
L	NA	NA	No lubricant level or pressure to observe Bearings are grease lubricated.		

BVPS-1 IST

PUMP TESTING OUTLINE

Pump Name: 4D Chemical Injection Pump		Pump Number: 1QS-P-4D	Code Class: 2	Dwg. OM No.: 13-1 Dwg. Coord.: G-9	System: 13 Containment Depressurization
Function: Chemical Injection during Containment Depressurization.			Type: Positive Displacement	Remarks: See RR1 and RR5.	
Parameter	1OST (Frequency)	Req'd	Comments		
N	NA	NA	Constant speed induction motor.		
PI	13.10B (Q)	RR5	Positive displacement pump. No suction pressure indication provided.		
ΔP	13.10B (U)	RR5	Positive displacement pump. Based on pump discharge pressure indicator [PI-1QS-400B], local.		
Q	13.10B (Q)	X	Will check using recirculation line flow indicator [FI-1QS-108], local.		
V	13.10B (Q)	RR1	Portable monitoring equipment using velocity units.		
Tb	NA	RR1	Annual pump bearing temperature measurements will not be taken since vibration is measured in velocity units.		
L	NA	NA	No lubricant level or pressure to observe. Bearings are grease lubricated.		

BVPS-1 IST

PUMP TESTING OUTLINE

Pump Name: 1A Inside Recirculation Spray Pump	Pump Number: 1RS-P-1A	Code Class: 2	Dwg. OM No.: 13-1 Dwg. Coord.: E-2	System: 13 Containment Depressurization
--	------------------------------	----------------------	---	--

Function: Circulate containment sump water for long term containment depressurization. **Type:** Vertical **Remarks:** See RR1, RR2 & RR6. Pump is normally tested dry in Modes 1 through 4, with flow during refueling outages only.

Parameter	10ST (Frequency)	Req'd	Comments
N	NA	NA	Constant speed induction motor.
Pi	13.3 (O)	RR6	Pump run dry for not more than 60 seconds and stopped when 100 rpm is reached.
	1BVT 1.13.5 (R)	RR2	Calculate Pi using the level in the sump, local.
ΔP	13.3 (O)	RR6	Pump run dry for not more than 60 seconds and stopped when 100 rpm is reached.
	1BVT 1.13.5 (R)	X	ΔP is calculated using the installed discharge pressure test gauge and the calculated Pi, local.
Q	13.3 (O)	RR6	Pump run dry for not more than 60 seconds and stopped when 100 rpm is reached.
	1BVT 1.13.5 (R)	X	Recirculation test line flow measured by differential pressure across local flow orifice.
V	13.3 (O)	RR6	Pump run dry for not more than 60 seconds and stopped when 100 rpm is reached.
	1BVT 1.13.5 (R)	RR1	Portable monitoring equipment using velocity units.
Tb	NA	RR1	Annual pump bearing temperature measurements will not be taken since vibration is measured in velocity units.
L	NA	NA	No lubricant level or pressure to observe. Lubrication is by the fluid being pumped.

BVPS-1 IST

PUMP TESTING OUTLINE

Pump Name: 1B Inside Recirculation Spray Pump		Pump Number: 1RS-P-1B	Code Class: 2	Dwg. OM No.: 13-1 Dwg. Coord.: E-3	System: 13 Containment Depressurization
Function: Circulate containment sump water for long term containment depressurization.		Type: Vertical		Remarks: See RR1, RR2 & RR6 Pump is normally tested dry in Modes 1 through 4, with flow during refueling outages only.	
Parameter	10ST (Frequency)	Req'd	Comments		
N	NA	NA	Constant speed induction motor.		
Pi	13.4 (Q)	RR6	Pump run dry for not more than 60 seconds and stopped when 100 rpm is reached		
	1BVT 1.13.5 (R)	RR2	Calculate Pi using the level in the sump, local		
ΔP	13.4 (Q)	R6	Pump run dry for not more than 60 seconds and stopped when 100 rpm is reached.		
	1BVT 1.13.5 (R)	X	ΔP is calculated using the installed discharge pressure test gauge and the calculated Pi, local.		
Q	13.4 (Q)	RR6	Pump run dry for not more than 60 seconds and stopped when 100 rpm is reached.		
	1BVT 1.13.5 (R)	X	Recirculation test line flow measured by differential pressure across local flow orifice.		
V	13.4 (Q)	RR6	Pump run dry for not more than 60 seconds and stopped when 100 rpm is reached.		
	1BVT 1.13.5 (R)	RR1	Portable monitoring equipment using velocity units.		
Tb	NA	RR1	Annual pump bearing temperature measurements will not be taken since vibration is measured in velocity units.		
L	NA	NA	No lubricant level or pressure to observe. Lubrication is by the fluid being pumped.		

Beaver Valley Power Station Unit 1
 INSERVICE TESTING (IST) PROGRAM FOR PUMPS AND VALVES
 Issue 2
 Revision 8
 Page 22 of 180

TESTING (IST) PROGRAM FOR PUMPS AND VALVES

BVPS-1 IST

PUMP TESTING OUTLINE

Pump Name	Pump Number	Code Class	Dwg. OM No.	System
2A Outside Recirculation Spray Pump	1RS-P-2A	2	13-1 F-5	13 Containment Depressurization
Function: Circulate containment sump water for long term; Type: Vertical containment depressurization.				
Remarks: See RR1 and RR7 Pump is normally tested dry in Modes 1 through 4, with flow during refueling outages only.				
Parameter	10ST (Frequency)	Req'd	Comments	
N	NA	NA	Constant speed induction motor	
Pi	13.5 (Q)	RR7	Pump run dry for not more than 60 seconds and stopped after visually observing an increase in motor amperage and pump shaft rotation.	
	13.7 (R)	X	No permanently installed suction pressure gauge, temporary test gauge installed at pump suction (Local)	
ΔP	13.5 (Q)	RR7	Pump run dry for not more than 60 seconds and stopped after visually observing an increase in motor amperage and pump shaft rotation.	
	13.7 (R)	X	ΔP is calculated using the installed Discharge Pressure Indicator [FI-1RS-156A], local, and local pressure gauge at pump suction.	
Q	13.5 (Q)	RR7	Pump run dry for not more than 60 seconds and stopped after visually observing an increase in motor amperage and pump shaft rotation.	
	13.7 (R)	X	Flow recorded using local Flow Indicator [FI-1RS-157A].	
V	13.5 (Q)	RR7	Pump run dry for not more than 60 seconds and stopped after visually observing an increase in motor amperage and pump shaft rotation.	
	13.7 (R)	PR1	Portable monitoring equipment using velocity units.	
Tb	NA	RR1	Annual pump bearing temperature measurements will not be taken since vibration is measured in velocity units.	
L	NA	NA	No lubricant level or pressure to observe. Lubrication is by the fluid being pumped.	

BVPS-1 IST

PUMP TESTING OUTLINE

Pump Name: 2B Outside Recirculation Spray Pump	Pump Number: 1RS-P-2B	Code Class: 2	Dwg. OM No.: 13-1 Dwg. Coord.: F-7	System: 13 Containment Depressurization
---	------------------------------	----------------------	---	--

Function: Circulate containment sump water for long term containment depressurization.	Type: Vertical	Remarks: See RR1 and RR7 Pump is normally tested dry in Modes 1 through 4, with flow during refueling outages only.
---	-----------------------	--

Parameter	10ST (Frequency)	Req'd	Comments
N	NA	NA	Constant speed induction motor.
PI	13.6 (Q)	RR7	Pump run dry for not more than 60 seconds and stopped after visually observing an increase in motor amperage and pump shaft rotation.
	13.7 (R)	X	No permanently installed suction pressure gauge, temporary test gauge installed at pump suction (local).
ΔP	13.6 (Q)	RR7	Pump run dry for not more than 60 seconds and stopped after visually observing an increase in motor amperage and pump shaft rotation.
	13.7 (R)	X	ΔP is calculated using the installed Discharge Pressure Indicator [FI-1RS-156B], local, and local pressure gauge at pump suction.
Q	13.6 (Q)	RR7	Pump run dry for not more than 60 seconds and stopped after visually observing an increase in motor amperage and pump shaft rotation.
	13.7 (R)	X	Flow recorded using local Flow Indicator [FI-1RS-157B].
V	13.6 (Q)	RR7	Pump run dry for not more than 60 seconds and stopped after visually observing an increase in motor amperage and pump shaft rotation.
	13.7 (R)	RR1	Portable monitoring equipment using velocity units.
Tb	NA	RR1	Annual pump bearing temperature measurements will not be taken since vibration is measured in velocity units.
L	NA	NA	No lubricant level or pressure to observe. Lubrication is by the fluid being pumped.

BVPS-1 IST

PUMP TESTING OUTLINE

Pump Name: 1A Component Cooling Water Pump		Pump Number: 1CC-P-1A	Code Class: 3	Dwg. OM No.: 15-1 Dwg. Coord.: E-6	System: 15 Reactor Plant Component Cooling Water
Function: To provide cooling water to RX Plant Components.			Type: Centrifugal	Remarks: See RR1	
Parameter	10ST (Frequency)	Req'd	Comments		
N	NA	NA	Constant speed induction motor.		
PI	15.1 (Q)	X	Local suction pressure indicators [PI-1CC-181, 183, or 185].		
ΔP	15.1 (Q)	X	Calculated using discharge pressure indicator [PI-1CC-100A] and pump suction pressure, local.		
Q	15.1 (Q)	X	Summation of total flow from indicators [FI-1CC-117], [FI-1CC-118] and [FI-1CC-119], Control Room, or local gages.		
V	15.1 (Q)	RR1	Portable monitoring equipment using velocity units.		
Tb	NA	RR1	Annual pump bearing temperature measurements will not be taken since vibration is measured in velocity units.		
L	15.1 (Q)	X	Bearing housing provided with sightglass at oil level reservoir indicator, local.		

BVPS-1 IST

PUMP TESTING OUTLINE

Pump Name: 1B Component Cooling Water Pump		Pump Number: 1CC-P-1B	Code Class: 3	Dwg. OM No.: 15-1 Dwg. Coord.: E-7	System: 15 Reactor Plant Component Cooling Water
Function: To provide cooling water to RX Plant Components.			Type: Centrifugal	Remarks: See RR1	
Parameter	10ST (Frequency)	Req'd	Comments		
N	NA	NA	Constant speed induction motor.		
PI	15.2 (Q)	X	Local suction pressure indicators [PI-1CC-181, 183, or 185].		
ΔP	15.2 (Q)	X	Calculated using discharge pressure indicator [PI-1CC-100B] and pump suction pressure, local.		
Q	15.2 (Q)	X	Summation of total flow from indicators [FI-1CC-117], [FI-1CC-118] and [FI-1CC-119], Control Room, or local gages.		
V	15.2 (Q)	RR1	Portable monitoring equipment using velocity units.		
Tb	NA	RR1	Annual pump bearing temperature measurements will not be taken since vibration is measured in velocity units.		
L	15.2 (Q)	X	Bearing housing provided with sightglass at oil level reservoir indicator, local.		

BVPS-1 IST

PUMP TESTING OUTLINE

Pump Name: 1C Component Cooling Water Pump	Pump Number: 1CC-P-1C	Code Class: 3	Dwg. OM No.: 15-1 Dwg. Coord.: E-8	System: 15 Reactor Plant Component Cooling Water
---	------------------------------	----------------------	---	---

Function: To provide cooling water to RX Plant Components. **Type:** Centrifugal **Remarks:** See RR1

Parameter	IGST (Frequency)	Req'd	Comments
N	NA	NA	Constant speed induction motor.
PI	15.3 (Q)	X	Local suction pressure indicators [PI-1CC-181, 183, or 185].
ΔP	15.3 (Q)	X	Calculated using discharge pressure indicator [PI-1CC-100C] and pump suction pressure, local.
Q	15.3 (Q)	X	Summation of total flow from indicators [FI-1CC-117], [FI-1CC-118] and [FI-1CC-119], Control Room, or local gages.
V	15.3 (Q)	RR1	Portable monitoring equipment using velocity units.
Tb	NA	RR1	Annual pump bearing temperature measurements will not be taken since vibration is measured in velocity units.
L	15.3 (Q)	X	Bearing housing provided with sightglass at oil level reservoir indicator, local.

BVPS-1 IST

PUMP TESTING OUTLINE

Pump Name: Steam Driven Auxiliary Feed Pump		Pump Number: 1FW-P-2		Code Class: 3		Dwg. OM No.: 24-2		System: 24 Auxiliary Feedwater	
Function: Provide emergency make-up during any loss of normal feedwater				Type: Centrifugal		Remarks: See RR1 and RR8. Pump is tested quarterly on recirculation flow and at full flow during cold shutdowns and refueling outages.			
Parameter	iOST (Frequency)	Req'd	Comments						
N	24.4 (Q)	X	No installed rpm indication. Use portable monitoring equipment-stroboscope.						
	24.9 (CSD,R)	X	No installed rpm indication. Use portable monitoring equipment-stroboscope.						
Pi	24.4 (Q)	X	Local suction pressure indicator [PI-1FW-156].						
	24.9 (CSD,R)	X	Local suction pressure indicator [PI-1FW-156].						
ΔP	24.4 (Q)	X	Calculated using discharge pressure indicator [PI-1FW-155] and pump suction pressure, local.						
	24.9 (CSD,R)	X	Calculated using discharge pressure indicator [PI-1FW-155] and pump suction pressure, local.						
Q	24.4 (Q)	RR8	Flow measurement performed at cold shutdowns and refueling outages.						
	24.9 (CSD,R)	X	Summation of flow to Steam Generators through flow indicators [FI-1FW-100A, B and C], Control Room.						
V	24.4 (Q)	RR1	Portable monitoring equipment using velocity units.						
	24.9 (CSD,R)	RR1	Portable monitoring equipment using velocity units.						
Tb	NA	RR1	Annual pump bearing temperature measurements will not be taken since vibration is measured in velocity units.						
L	24.4 (Q)	X	Visual check of oil level in oil pump suction line.						
	24.9 (CSD,R)	X	Visual check of oil level in oil pump suction line.						

BVPS-1 IST

PUMP TESTING OUTLINE

Pump Name: 3A Motor Driven Auxiliary Feed Pump	Pump Number: 1FW-P-3A	Code Class: 3	Dwg. OM No.: 24-2 Dwg. Coord.: F-2	System: 24 Auxiliary Feedwater
---	------------------------------	----------------------	---	---------------------------------------

Function: Provide emergency make-up during any loss of normal feedwater	Type: Centrifugal	Remarks: See RR1 and RR8. Pump is tested quarterly on recirculation flow and at full flow during cold shutdowns and refueling outages.
--	--------------------------	---

Parameter	10ST (Frequency)	Req'd	Comments
N	NA	NA	Constant speed induction motor.
PI	24.2 (Q)	X	Local suction pressure indicator [PI-1FW-156A].
	24.8 (CSD,R)	X	Local suction pressure indicator [PI-1FW-156A].
ΔP	24.2 (Q)	X	Calculated using discharge pressure indicator [PI-1FW-155A] and pump suction pressure, local.
	24.8 (CSD,R)	X	Calculated using discharge pressure indicator [PI-1FW-155A] and pump suction pressure, local.
Q	24.2 (Q)	RR8	Flow measurement performed at cold shutdowns and refueling outages.
	24.8 (CSD,R)	X	Summation of flow to Steam Generators through flow indicators [FI-1FW-100A, B and C], Control Room.
V	24.2 (Q)	RR1	Portable monitoring equipment using velocity units.
	24.8 (CSD,F)	RR1	Portable monitoring equipment using velocity units.
Tb	NA	RR1	Annual pump bearing temperature measurements will not be taken since vibration is measured in velocity units.
L	24.2 (Q)	X	Visual check of oil level in oil pump suction line.
	24.8 (CSD,R)	X	Visual check of oil level in oil pump suction line.

BVPS-1 IST

PUMP TESTING OUTLINE

Pump Name: 3B Motor Driven Auxiliary Feed Pump	Pump Number: 1FW-P-3B	Code Class: 3	Dwg. OM No.: 24-2 Dwg. Coord.: F-5	System: 24 Auxiliary Feedwater
---	------------------------------	----------------------	---	---------------------------------------

Function: Provide emergency make-up during any loss of normal feedwater
Type: Centrifugal
Remarks: See RR1 and RR8. Pump is tested quarterly on recirculation flow and at full flow during cold shutdowns and refueling outages.

Parameter	10ST (Frequency)	Req'd	Comments
N	NA	NA	Constant speed induction motor.
Pi	24.3 (O)	X	Local suction pressure indicator [PI-1FW-156B].
	24.8 (CSD,R)	X	Local suction pressure indicator [PI-1FW-156B].
ΔP	24.3 (O)	X	Calculated using discharge pressure indicator [PI-1FW-155B] and pump suction pressure, local.
	24.8 (CSD,R)	X	Calculated using discharge pressure indicator [PI-1FW-155B] and pump suction pressure, local.
Q	24.3 (O)	RR8	Flow measurement performed at cold shutdowns and refueling outages.
	24.8 (CSD,R)	X	Summation of flow to Steam Generators through flow indicators [FI-1FW-100A, B and C], Control Room.
V	24.3 (O)	RR1	Portable monitoring equipment using velocity units.
	24.8 (CSD,R)	RR1	Portable monitoring equipment using velocity units.
Tb	NA	RR1	Annual pump bearing temperature measurements will not be taken since vibration is measured in velocity units.
L	24.3 (O)	X	Visual check of oil level in oil pump suction line.
	24.8 (CSD,R)	X	Visual check of oil level in oil pump suction line.

BVPS-1 IST

PUMP TESTING OUTLINE

Pump Name: 1A River Water Pump		Pump Number: 1WR-P-1A	Code Class: 3	Dwg. OM No.: 30-1 Dwg. Coord.: B-1	System: 30 River Water
Function: To provide a source of water during normal and emergency conditions to primary plant heat exchangers and equipment.			Type: Vertical	Remarks: See RR1 and RR2	
Parameter	1OST (Frequency)	Req'd	Comments		
N	NA	NA	Constant speed induction motor.		
Pi	30.2 (Q)	RR2	No installed instrumentation to measure suction pressure. Calculate Pi using the Ohio river level recorder [LR-1CW-101], local.		
ΔP	30.2 (Q)	X	ΔP is calculated using the pump discharge pressure indicator [PI-1RW-101A] and the calculated Pi, local.		
Q	30.2 (Q)	X	Flow indicator [FI-1RW-102A], Control Room.		
V	30.2 (Q)	RR1	Portable monitoring equipment using velocity units.		
Tb	NA	RR1	Annual pump bearing temperature measurements will not be taken since vibration is measured in velocity units.		
L	NA	NA	No lubricant level or pressure to observe. Lubrication is by the fluid being pumped.		

BVPS-1 IST

PUMP TESTING OUTLINE

Pump Name: 1B River Water Pump	Pump Number: 1WR-P-1B	Code Class: 3	Dwg. OM No.: 30-1 Dwg. Coord.: C-1	System: 30 River Water
Function: To provide a source of water during normal and emergency conditions to primary plant heat exchangers and equipment.	Type: Vertical	Remarks: See RR1 and RR2		

Parameter	10ST (Frequency)	Req'd	Comments
N	NA	NA	Constant speed induction motor.
Pi	30.3 (Q)	RR2	No installed instrumentation to measure suction pressure. Calculate Pi using the Ohio river level recorder [LR-1CW-101], local.
ΔP	30.3 (Q)	X	ΔP is calculated using the pump discharge pressure indicator [PI-1RW-101B] and the calculated Pi, local.
Q	30.3 (Q)	X	Flow indicator [FI-1RW-102B], Control Room.
V	30.3 (Q)	RR1	Portable monitoring equipment using velocity units.
Tb	NA	RR1	Annual pump bearing temperature measurements will not be taken since vibration is measured in velocity units.
L	NA	NA	No lubricant level or pressure to observe. Lubrication is by the fluid being pumped.

BVPS-1 IST

PUMP TESTING OUTLINE

Pump Name: 1C River Water Pump	Pump Number: 1WR-P-1C	Code Class: 3	Dwg. OM No.: 30-1	System: 30 River Water	
			Dwg. Coord.: D-1		
Function: To provide a source of water during normal and emergency conditions to primary plant heat exchangers and equipment.		Type: Vertical	Remarks: See RR1 and RR2		

Parameter	1OST (Frequency)	Req'd	Comments
N	NA	NA	Constant speed induction motor.
PI	30.6 (Q)	RR2	No installed instrumentation to measure suction pressure. Calculate Pi using the Ohio river level recorder [LR-1CW-101], local.
ΔP	30.6 (Q)	X	ΔP is calculated using the pump discharge pressure indicator [PI-1RW-101C] and the calculated Pi, local.
Q	30.6 (Q)	X	Flow indicator [FI-1RW-102A or B], Control Room.
V	30.6 (Q)	RR1	Portable monitoring equipment using velocity units.
Tb	NA	RR1	Annual pump bearing temperature measurements will not be taken since vibration is measured in velocity units.
L	NA	NA	No lubricant level or pressure to observe. Lubrication is by the fluid being pumped.

BVPS-1 IST

PUMP TESTING OUTLINE

Pump Name: 1A DG #1 Fuel Transfer Pump		Pump Number: 1EE-P-1A	Code Class: 3	Dwg. OM No.: 36-2 Dwg. Coord.: B-4	System: 36 Station Service 4KV
Function: Transfer fuel from the underground tank to the day tank.			Type: Positive Displacement	Remarks: See RR1, RR9 and RR10. Pump is normally tested monthly.	
Parameter	10ST (Frequency)	Req'd	Comments		
N	NA	NA	Constant speed induction motor.		
Pi	36.1 (Q)	RR9	No suction pressure at pump due to physical location of suction tank (underground). Pump is self priming and no suction pressure gauge is installed (positive displacement pump).		
ΔP	36.1 (Q)	RR9	ΔP across a positive displacement pump is meaningless in determining pump degradation. Based on pump discharge pressure indicator [PI-1EE-101A], local.		
Q	36.1 (Q)	RR10	No instrumentation provided - Level change over time in the day tank will be measured and converted to flowrate.		
V	36.1 (Q)	RR1	Portable monitoring equipment using velocity units.		
Tb	NA	RR1	Annual pump bearing temperature measurements will not be taken since vibration is measured in velocity units.		
L	NA	NA	No lubricant level or pressure to observe. Lubrication is by the fluid being pumped.		

BVPS-1 IST

PUMP TESTING OUTLINE

Pump Name: 1B DG #1 Fuel Transfer Pump		Pump Number: 1EE-P-1B	Code Class: 3	Dwg. OM No.: 36-2 Dwg. Coord.: A-4	System: 36 Station Service 4KV
Function: Transfer fuel from the underground tank to the day tank.			Type: Positive Displacement	Remarks: See RR1, RR9 and RR10. Pump is normally tested monthly.	
Parameter	10ST (Frequency)	Req'd	Comments		
N	NA	NA	Constant speed induction motor.		
PI	36.1 (Q)	RR9	No suction pressure at pump due to physical location of suction tank (underground). Pump is self priming and no suction pressure gauge is installed (positive displacement pump).		
ΔP	36.1 (Q)	RR9	ΔP across a positive displacement pump is meaningless in determining pump degradation. Based on pump discharge pressure indicator [PI-1EE-101A], local.		
Q	36.1 (Q)	RR10	No instrumentation provided - Level change over time in the day tank will be measured and converted to flowrate.		
V	36.1 (Q)	RR1	Portable monitoring equipment using velocity units.		
Tb	NA	RR1	Annual pump bearing temperature measurements will not be taken since vibration is measured in velocity units.		
L	NA	NA	No lubricant level or pressure to observe. Lubrication is by the fluid being pumped.		

BVFS 1 IST

PUMP TESTING OUTLINE

Pump Name: 1C DG #2 Fuel Transfer Pump		Pump Number: 1EE-P-1C	Code Class: 3	Dwg. Ord No.: 36-2 Dwg. Coord.: F 4	System: 36 Station Service 4KV
Function: Transfer fuel from the underground tank to the day tank.			Type: Positive Displacement	Remarks: See RR1, RR9 and RR10. Pump is normally tested monthly.	
Parameter	FOST (Frequency)	Req'd	Comments		
N	NA	NA	Constant speed induction motor.		
Pi	36.2 (Q)	RR3	No suction pressure at pump due to physical location of suction tank (underground). Pump is self priming and no suction pressure gauge is installed (positive displacement pump).		
ΔP	36.2 (Q)	RR9	ΔP across a positive displacement pump is meaningless in determining pump degradation. Based on pump discharge pressure indicator [PI-1EE-102A], local.		
Q	36.2 (Q)	RR10	No instrumentation provided - Level change over time in the day tank will be measured and converted to flowrate.		
V	36.2 (Q)	RR1	Portable monitoring equipment using velocity units.		
Tb	NA	RR1	Annual pump bearing temperature measurements will not be taken since vibration is measured in velocity units.		
L	NA	NA	No lubricant level or pressure to observe. Lubrication is by the fluid being pumped.		

B/P-1: IST

PUMP TESTING OUTLINE

Pump Name: 1D DG #2 Fuel Transfer Pump		Pump Number: 1EE-P-1D	Code Class: 3	Dwg. OM No.: 36-2 Dwg. Ord.: E-4	System: 36 Station Service 4KV
Function: Transfer fuel from the underground tank to the day tank.			Type: Positive Displacement	Remarks: See RR1, RR9 and RR10. Pump is normally tested monthly.	
Parameter	10ST (Frequency)	Req'd	Comments		
N	NA	NA	Constant speed induction motor.		
Pi	36.2 (C)	RR9	No suction pressure at pump due to physical location of suction tank (underground). Pump is self priming and no suction pressure gauge is installed (positive displacement pump).		
ΔP	36.2 (C)	RR9	ΔP across a positive displacement pump is meaningless in determining pump degradation. Based on pump discharge pressure indicator [PI-1ES-102A], recall.		
Q	35.2 (Q)	RR10	No instrumentation provided - Level change over time in the day tank will be measured and converted to flowrate.		
V	36.2 (Q)	RR1	Portable monitoring equipment using velocity units.		
Tb	NA	RR1	Annual pump bearing temperature measurements will not be taken since vibration is measured in velocity units.		
L	NA	NA	No lubricant level or pressure to observe. Lubrication is by the fluid being pumped.		

SECTION III: PUMP TESTING RELIEF REQUESTS

RELIEF REQUEST 1**Pump Mark No(s):**

1CH-P-1A	1QS-P-4A	1RS-P-2B	1WR-P-1A
1CH-P-1B	1QS-P-4B	1CC-P-1A	1WR-P-1B
1CH-P-1C	1QS-P-4C	1CC-P-1B	1WR-P-1C
1CH-P-2A	1QS-P-4D	1CC-P-1C	1EE-P-1A
1CH-P-2B	1RS-P-1A	1FW-P-2	1EE-P-1B
1QS-P-1A	1RS-P-1B	1FW-P-3A	1EE-P-1C
1QS-P-1B	1RS-P-2A	1FW-P-3B	1EE-P-1D

Code Test Requirement: Quarterly Vibration amplitude measurements in mils and annual Bearing Temperature Measurements.

Basis for Relief: The mechanical characteristics of a pump can be better determined by taking vibration measurements in velocity units than by taking the vibration measurements in displacement units and by bearing temperature measurements taken annually.

Vibration severity is a function of both displacement and frequency. Therefore, vibration in velocity units is the more accurate description of the vibration. In addition, velocity measurements are more sensitive to small changes that are indicative of developing mechanical problems and hence more meaningful than displacement measurements. Velocity measurements detect not only high amplitude vibrations that indicate a major mechanical problem, but also the equally harmful low amplitude high frequency vibrations due to misalignment, imbalance or bearing wear that usually go undetected by simple displacement measurements. Also, a bearing will be seriously degraded prior to the detection of increased heat at the bearing housing. Quarterly vibration velocity readings should achieve a much higher probability of detecting developing problems than the once a year reading of bearing temperatures. Therefore, relief is requested from measuring bearing temperatures annually and from measuring pump vibration in displacement units (mils).

Alternate Test: Obtain pump vibration measurements in accordance with the vibration measurement requirements and corrective actions of ANSI/ASMF OM-6, and measure vibration in velocity units (in/sec) using the ranges listed in OM-6 (revision 8) as acceptance criteria. (See the attached table). Annual pump bearing temperature measurements will not be taken.

RELIEF REQUEST 1

TABLE

RANGES OF TEST PARAMETERS (.)

<u>PUMP TYPE</u>	<u>TEST PARAMETER</u>	<u>ACCEPTABLE RANGE</u>	<u>ALERT RANGE</u>	<u>REQUIRED ACTION RANGE</u>
Centrifugal (2) and Vertical Line Shaft (3)	Vv	$\leq 2.5 V_r$	> 2.5 Vr to 6 Vr but not > 0.325 in/sec	> 6 Vr but not > 0.70 in/sec
Reciprocating (4)	Vv	$\leq 2.5 V_r$	> 2.5 Vr to 6 Vr	> 6 Vr

Notes:

1. Vv represents the peak vibration velocity. Vr is vibration reference value in the selected units.
2. On centrifugal pumps, measurements shall be taken in a plane approximately perpendicular to the rotating shaft in two orthogonal directions on each accessible pump bearing housing. Measurement also shall be taken in the axial direction on each accessible pump thrust bearing housing.
3. On vertical line shaft pumps, measurements shall be taken on the upper motor bearing housing in three orthogonal directions, one of which is the axial direction.
4. On reciprocating pumps, the location shall be on the bearing housing of the crankshaft, approximately perpendicular to both the crankshaft and the line of plunger travel.

RELIEF REQUEST 2

Pump Mark No(s):

*1CH-P-1A	1CH-P-2B	*1QS-P-1B	1WR-P-1A
*1CH-P-1B	1SI-P-1A	1RS-P-1A	1WR-P-1B
*1CH-P-1C	1SI-P-1B	1RS-P-1B	1WR-P-1C
1CH-P-2A	*1QS-P-1A		

* Interim relief is granted for these pumps until 9R only.

Code Test Requirement: Measurement of pump suction pressure before pump startup and during test.

Basis for Relief: No installed instrumentation exists to measure suction pressure, therefore, relief is requested from this requirement.

Alternate Test: The static head from tanks or the Ohio River elevation will be used to calculate suction pressure, once per test.

RELIEF REQUEST 3

Pump Mark No(s):

1CH-P-2A
1CH-P-2B

Code Test Requirement: Measurement of flow and ΔP .

Basis for Relief: These pumps are tested in fixed resistance recirculation lines. Therefore, either the measured flowrate or the measured differential pressure can be considered constant and at its reference value. The other test quantities may then be measured or observed and recorded.

Alternate Test: Test quarterly through their recirculation lines while measuring pump ΔP per 1OST-7.1 & 2. Test during refueling outages per 1OST-7.13 & 14 by measuring pump ΔP and by calculating flow. Flow will be calculated by transferring water between boric acid tanks and measuring the change in tank level over time, when technical specifications require only one of two boric acid sources and flow paths to be operable. Testing in this manner will require partially draining down one tank to make room for the transfer.

RELIEF REQUEST 4**Pump Mark No(s):**

1RH-P-1A

1RH-P-1B

Code Test Requirement: Quarterly pump testing.

Basis for Relief: Testing the RHR pumps quarterly would require making an entry into the subatmospheric containment. In addition, any testing done at power would be limited to the pump recirculation flow path due to pressure and temperature interlocks between the RHR and RC Systems which prevent lining up the two systems at power. The pump recirculation flow path lacks the necessary instrumentation to measure pump flow rate.

Alternate Test: These pumps will be tested quarterly during cold shutdowns and refueling outages per 1OST-10.1.

RELIEF REQUEST 5**Pump Mark No(s):**

1QS-P-4A

1QS-P-4B

1QS-P-4C

1QS-P-4D

Code Test Requirement: Measure suction pressure, ΔP and flow.

Basis for Relief: The function of these pumps is to provide NaOH water to the suction of the quench spray pumps during an accident. Since these pumps are positive displacement, flow rate and differential pressure are independent variables. Unlike centrifugal style pumps, it is not necessary to measure both parameters to assess the hydraulic performance of these pumps.

Alternate Test: Pump discharge pressure and flow rate will be utilized for evaluating pump performance.

RELIEF REQUEST 6

Pump Mark No(s):

1RS-P-1A

1RS-P-1B

Code Test Requirement: Quarterly pump tests.

Basis for Relief: The function of these pumps is to take suction on the containment sump and discharge to the spray rings on the containment ceiling during a DBA. In order to test these pumps, a temporary dike must be installed in the containment around the sump to ensure adequate NPSH for each pump. Quarterly testing at power in this manner is a safety concern since it would block off the sump from the containment in the event of an accident. Pump testing during cold shutdowns, while not involving the same safety concern, would increase personnel radiation exposure, create over 2,000 gallons of additional radioactive waste, divert maintenance from higher priority items, and could extend the length of a plant shutdown due to the extensive preparatory work required to properly install the dike.

Alternate Test: Dry run quarterly per 1OST-13.3 and 13.4 for not more than 60 seconds and stopped when they reach 100 rpm. Also, run on recirculation per 1BVT 1.13.5 during refueling outages.

RELIEF REQUEST 7**Pump Mark Co(s):**

1RS-P-2A

1RS-P-2B

Code Test Requirement: Quarterly pumps test.

Basis for Relief: The function of these pumps is to take suction on the containment sump and discharge to the spray rings inside containment. The pumps are designed with a recirculation flow path for testing; however, the piping arrangement and required valve lineup for post-test system restoration prevents draining the pump casing and suction lines without returning some water to the sump in the containment building. As a result, a containment entry is required to pump the sump down. Performing this test also creates radioactive waste, increases personnel radiation exposure and could increase the maintenance required on the pump suction and discharge MOVs which must be cycled closed to perform this test placing a differential pressure across these valves not normally seen under either normal or accident conditions.

Alternate Test: Run dry quarterly per 1OST-13.5 and 13.6 for not more than 60 seconds and stopped after visually observing an increase in motor amperage and pump shaft rotation. Also, run on recirculation per 1OST-13.7 during refueling outages.

RELIEF REQUEST 8**Pump Mark No(s):**

1FW-P-2
1FW-P-3A
1FW-P-3B

Code Test Requirement: Measurement of flow and ΔP .

Basis for Relief: These pumps are tested in fixed resistance recirculation lines. Therefore, either the measured flowrate or the measured differential pressure can be considered constant and at its reference value. The other test quantities may then be measured or observed and recorded.

Alternate Test: Test quarterly through their recirculation lines while measuring pump ΔP per 1OSTs-24.2, 3, & 4. Test during cold shutdown and refueling outages when plant conditions permit directing flow to the steam generators. Measure pump ΔP and flowrate using the flow instrumentation in the S/G supply headers per 1OSTs-24.8 & 9.

RELIEF REQUEST 9**Pump Mark No(s):**

1EE-P-1A
1EE-P-1B
1EE-P-1C
1EE-P-1D

Code Test Requirement: Measure suction pressure and ΔP .

Basis for Relief: Relief is requested from measuring suction pressure and differential pressure due to a lack of installed instrumentation. Also, these are positive displacement pumps and the flowrate is more indicative of pump degradation than the pressures are.

Alternate Test: Discharge pressure is recorded and trended as a further indication of pump performance.

RELIEF REQUEST 10

Pump Mark No(s):

1EE-P-1A

1EE-P-1B

1EE-P-2

1EE-P-3

Code Test Requirement:

Flowrate shall be measured using a rate or quantity meter installed in the pump test circuit.

Basis for Relief:

There is no installed instrumentation.

Alternate Test:

The level change over time in the floor mounted day tank will be measured and converted to the flowrate.

SECTION IV: VALVE TESTING REQUIREMENTS

The Inservice Test (IST) Program for valves at Beaver Valley Power Station (BVPS), Unit 1, is based on subsection IWV - Inservice Testing of Valves of the ASME Boiler and Pressure Vessel Code, Section XI, 1983 edition through the summer 1983 addenda (the code) and Generic Letter No. 89-04, "Guidance on Developing Acceptable Inservice Testing Programs". The valves included in this section are all ASME "Class 1, 2, or 3 valves (and their actuating and position indicating systems) which are required to perform a specific function in shutting down the reactor to cold shutdown or in mitigating the consequences of an accident" at BVPS, Unit 1.

The requirements of the code will be followed at all times unless specific relief has been granted by the NRC.

- A. Category A valves are valves for which seat leakage in the closed position is limited to a specific maximum amount for fulfillment of their function. Category B valves are valves for which seat leakage in the closed position is inconsequential for fulfillment of their function. Category A and B valves will be exercised at least once every three months to the position required to fulfill their function unless such operation is not practical during plant operation. If only limited operation is practical during plant operation, the valves will be part-stroke exercised at power and full-stroke exercised during cold shutdowns. In the case of frequent cold shutdowns, these valves need not be tested more often than once every three months. For a valve in a system declared inoperable or not required to be operable, the exercising test schedule need not be followed. Within 30 days prior to return of the system to operable status, the valves shall be exercised and the schedule resumed.

The time to full-stroke exercise each power-operated valve will also be measured and compared to a limiting stroke time. Full-stroke time is that time interval from initiation of the actuating signal to the end of the actuating cycle. The stroke time of all power-operated valves shall be measured to at least the nearest second, for stroke times 10 seconds or less, or 10% of the specified limiting stroke time for full-stroke times longer than 10 seconds, whenever such a valve is full-stroke tested. Position indication lights on the control board are used for valve stroke indication for all testing of power-operated valves with remote position indicators. In addition, valves with remote position indicators will be observed at least once every 2 years (normally at refuelings) to verify that valve operation is accurately indicated.

Exception is taken to part-stroke testing motor-operated valves, unless specifically stated. This is necessary because the motor-operated valve circuitry prevents throttling of these valves. Under normal operation, the valves must travel to either the full open or shut position prior to reversing direction.

The necessary valve disk movement shall be determined by exercising the valve while observing an appropriate indicator, which signals the required change of disk position, or observing indirect evidence (such as changes in system pressure, flow rate, level, or temperature), which reflect stem or disk position.

All valves with fail-safe actuators (ie., air-operated valves) that are applicable to this program are tested from the Control Room by the remote operating switch. By placing the control switch to the closed position, or de-energizing the control power, air is vented off of the valve actuator thus positioning the valve in the fail-safe position.

Corrective action shall be taken if necessary, using the following:

1. If the stroke time of a power-operated valve exceeds its previous stroke time by 25% for valves with full-stroke times greater than 10 seconds, or 50% for valves with full-stroke times less than or equal to 10 seconds, the test frequency will be increased to monthly. Stroke times of the valves will be examined for trends. During the trend review, it will be determined if corrective action is necessary for any valve based on its stroke time history. When either the corrective action is complete or the review determines it is unnecessary, the original test frequency will be resumed.
2. If a valve fails to exhibit the required change of valve stem or disk position or exceeds its specified ASME limiting value of full-stroke time, then the valve shall be declared inoperable immediately and an evaluation of the valve's condition with respect to system operability and technical specifications shall be made as follows:
 - a. If the inoperable valve is specifically identified in the technical specifications, then the applicable technical specification action statements must be followed.
 - b. If the inoperable valve is in a system covered by a technical specification, an assessment of its condition must be made to determine if it makes the system inoperable. If the condition of the valve renders the system inoperable, then the applicable system technical specification action statements must be followed.
 - c. Corrective action (i.e., MWR) shall be initiated immediately for the valve's repair or replacement.
 - d. Nothing in the ASME Boiler and Pressure Vessel Code shall be construed to supercede the requirements of any technical specification.
 - e. If the valve is not covered by any technical specifications and the condition of the valve cannot be corrected within 24 hours, then the valve shall be declared inoperable per ASME.
3. When a valve or its control system has been replaced or repaired or has undergone maintenance that could affect its performance, and prior to the time it is returned to service, it shall be tested to demonstrate that the performance parameters, which could be affected by the replacement, repair, or maintenance, are within acceptable limits. Examples of maintenance that could affect valve performance parameters are adjustment of stem packing, removal of the bonnet, stem assembly, or actuator, and disconnection of hydraulic or electrical lines.

The ASME limiting valve stroke time is based on the following criteria:

1. The Technical Specification value.
2. ESF Response Time requirements.
3. Establishing a five (5) second limit for valves with stroke times under two (2) seconds.
4. The average of past stroke times plus 100% for valves with stroke times less than or equal to ten (10) seconds.

5. The average of past stroke times plus 50% for valves with stroke times greater than ten (10) seconds.
6. The design time listed in the UFSAR.

In addition, Category A valves are leak rate tested at the same (or greater) frequency as scheduled refueling outages, not to exceed every two years. If the leak rate exceeds the allowable limit, the valve will be repaired or replaced.

- B. Category C valves are valves which are self-actuating in response to some system characteristic, such as pressure (relief valves) or flow direction (check valves). Category C valves are divided into two groups; safety or relief valves and check valves.

Safety and relief valves are setpoint tested in accordance with ASME PTC 25.3-1976 at least once every five (5) years, with a portion of the valves from each system included in the IST Program tested during each refueling outage. If any valves fail the setpoint test, additional valves from that system must be tested in accordance with Table IWV-3510-1. If a safety or relief valve fails to function properly during a test, it will be repaired or replaced.

Check valves will be exercised to the position required to fulfill their function every three months, unless such operation is not practical during plant operation. If only limited operation is practical during plant operation, the check valve will be part-stroke exercised at power and full-stroke exercised every cold shutdown, not to exceed more than once every three months. Check valves that are normally open during plant operation and whose function is to prevent reversed flow shall be tested in a manner that proves that the disk travels to the seat promptly on cessation or reversal of flow. Check valves that are normally closed during plant operation and whose function is to open on reversal of pressure differential shall be tested by proving that the disk moves promptly away from the seat when the closing pressure differential is removed and flow through the valve is initiated, or when a mechanical opening force is applied to the disk.

If a check valve fails to exhibit the required change of disk position by this testing, then the check valve shall be declared inoperable immediately and an evaluation of the check valve's condition with respect to system operability and technical specifications shall be made as follows:

1. If the inoperable check valve is specifically identified in the technical specifications, then the applicable technical specification action statements must be followed.
2. If the inoperable check valve is in a system covered by a technical specification, an assessment of its condition must be made to determine if it makes the system inoperable. If the condition of the check valve renders the system inoperable, then the applicable system technical specification action statements must be followed.
3. Corrective action (ie., MWR) shall be initiated immediately for the check valve's repair or replacement.
4. Nothing in the ASME Boiler and Pressure Vessel Code shall be construed to supercede the requirements of any technical specification.

5. If the check valve is not covered by any technical specifications and the condition of the check valve cannot be corrected within 24 hours, then the check valve shall be declared inoperable per ASME.

Before returning the check valve to service after corrective action, a retest showing acceptable operation will be run.

- C. Category D valves are valves which are actuated by an energy source capable of only one operation, such as rupture disks or explosively actuated valves. There are no ASME Class 1, 2, or 3 Category D valves at BVPS, Unit 1.

All the inservice testing requirements for each different category of valve in the IST Program are summarized in Table IWV-3700-1. This table lists the subarticles of the code that apply to each different type of valve.

Table IWV-3700-1
INSERVICE TEST QUANTITIES (1)

Category	Valve Function (IWV-2100)	Leak Test Procedure	Exercise Test Procedure	Special Test Procedure
A	Active	IWV-3420	IWV-3410	None
A	Passive	IWV-3420	None	None
B	Active	None	IWV-3410	None
C-Safety & Relief	Active	None	IWV-3510	None
C-Check	Active	None	IWV-3520	None
D	Active	None	None	IWV-3600

NOTE:

(1) No tests required for Category B, C and D passive valves.

Passive valves are valves which are not required to change position to accomplish a specific function. As stated in the table, passive valves are not required to be exercised. Therefore, relief is not required from exercising any passive valve and no testing requirement is listed in the outline section except when remote position verification is required.

Certain exemptions from the valve testing requirements of the ASME code defined by subsection IWV-1200 are listed below:

1. Valves used only for operating convenience (ie., manual vent, drain, instrument and test valves);
2. Valves used only for system control (ie., pressure, temperature or flow regulating valves);
3. Valves used only for maintenance; and
4. External control and protection systems responsible for sensing plant conditions and providing signals for valve operation.

Records of the results of inservice tests and corrective actions as required by subsection IWV-6000 are maintained in tabular form. Stroke times of valves will be reviewed for developing trends.

If a question on valve testability exists, the IST program should be the controlling document since each component is individually assessed for testability and inclusion in the IST Program. If a valve is specifically called out in the Tech. Specs. (ie., specific valve mark number or uniquely specified by valve nomenclature) to be tested at one frequency and the IST Program endorses another frequency, then the more restrictive test frequency would be applicable.

The following three sections of this document are the "Valve Testing Outlines", "Cold Shutdown Justifications" and "Valve Relief Requests" sections.

- A. The "Valve Testing Outlines" section is a listing of all the valves in the IST Program, their class, category, size, type, NSA, drawing number and coordinates, testing requirements, specific cold shutdown justification reference numbers, relief request reference numbers, and test procedure numbers and comments.
1. The valve class will be 1, 2 or 3, corresponding to the safety classifications.
 2. The category of the valve will be A, B, C or D in accordance with the guidelines of subsection IWV-2200. In addition, combinations of categories may be utilized. If the valve is not required to change position during an accident or bring the reactor to a cold shutdown condition, the fact that it is Passive (P) will also be indicated. For example, a containment isolation check valve that does not change position would be a category A/C/P valve. From the valve mark number given, the valve actuator can be determined from the list of abbreviations below:
 - FCV - Flow Control Valve
 - HCV - Hand Control Valve
 - LCV - Level Control Valve
 - MOV - Motor Operated Valve
 - NRV - Non Return Valve
 - PCV - Pressure Control Valve
 - RV - Relief Valve
 - SOV - Solenoid Operated Valve
 - SV - Safety Valve
 - TV - Trip Valve
 - D - Damper
 3. The normal system arrangement will be listed using the abbreviations below:
 - NSA - Normal System Arrangement
 - O - Open
 - S - Shut
 - A - Automatic
 - T - Throttled
 - LO - Locked Open
 - LS - Locked Shut
 4. The drawing number and coordinates will be the ones used in the Operating Manual.

5. The test requirements will be listed using the abbreviations below:
 - QS - Quarterly Stroke
 - QST - Quarterly Stroke & Time
 - LT - Leak Rate Test
 - SPT - Set Point Test
 - LM - Leakage Monitoring
 - POS - Position Verification
 - NA - Not Applicable
 6. The specific Cold Shutdown Justification (CSJ) reference number or the Relief Request (RR) reference number will be listed.
 7. The specific test procedure number, frequency, type of testing, and any comments will be listed using the abbreviations below:
 - 1OM - Operating Manual (Unit 1)
 - 1BVT - Beaver Valley Test (Unit 1)
 - 1OST - Operating Surveillance Test (Unit 1)
 - CMP - Corrective Maintenance Procedure
 - CSD - Cold Shutdown Frequency
 - R - Refueling Frequency
 - SA - Semiannual Frequency
 - Q - Quarterly Frequency
 - M - Monthly Frequency
 - W - Weekly Frequency
 - S - Shiftly Frequency
 - FS - Full Stroke
 - PS - Partial Stroke
 - FD - Forward Direction
 - RD - Reverse Direction
 - RPV - Remote Position Verification normally at Refueling
- B. The "Cold Shutdown Justification" section contains the detailed technical description of conditions prohibiting the required testing of safety-related valves and an alternate test method to be performed during cold shutdowns. Cold Shutdown valve testing will commence within 48 hours of reaching cold shutdown conditions, but need not be completed more often than once every 92 days. Attempts will be made to complete testing prior to entering Mode 4. However, completion will not be a Mode 4 requirement. The testing will resume where left off when next entering Mode 5. For planned cold shutdowns, where ample time is available to complete testing on all valves identified for the cold shutdown test frequency, exceptions to the 48 hour requirement can be taken.
- BVPS Unit 1 reactor containment is maintained subatmospheric as required by technical specifications. The subatmospheric condition presents a hazardous working environment for station personnel and is considered inaccessible for surveillance testing. Surveillance testing that requires reactor containment entry will be performed at cold shutdown and refueling.
- C. The "Valve Relief Requests" section contains the detailed technical description of conditions prohibiting the required testing of safety-related valves, an alternate test method and frequency of revised testing.

SECTION V:

VALVE TESTING OUTLINES

BVPS-1 IST

VALVE TESTING OUTLINE

SYSTEM NAME: Reactor Coch						SYSTEM NUMBER: 6				
Valve Mark Number	Valve Class	Valve Category	Valve Size (in.)	Valve Type	NSA	Drawing		Test Requirement	CSJ or Relief Requests	Comments
						OM No.	Coord.			
1RC-68	2	A/C	3/4	Check		6-2	B-3	QS	RR2	1BVT 1.47.5-FS, RD by Leak Test (R)
								LT	RR1	1BVT 1.47.5-Leak Test (R)
1RC-72	2	A/C	3	Check		6-2	C-3	QS	RR3	1BVT 1.47.5-FS, RD by Leak Test (R)
								LT	RR1	1BVT 1.47.5-Leak Test (R)
TV-1RC-101	2	A	3/4	Globe	S	6-2	B-2	QST		1OST-47.3A(3B) Stroke & Time Closed (Q) (RPV)
								LT	RR1	1BVT 1.47.5-Leak Test (R)
SOV-1RC-102A	1	B	1	Globe	LS	6-2	A-1	QST	CSJ1	1OST-1.10-Stroke & Time Open (CSD) 1OST-6.9-(RPV)
SOV-1RC-102B	1	B	1	Globe	LS	6-2	A-1	QST	CSJ1	1OST-1.10-Stroke & Time Open (CSD) 1OST-6.9-(RPV)
SOV-1RC-103A	1	B	1	Globe	LS	6-2	A-2	QST	CSJ1	1OST-1.10-Stroke & Time Open (CSD) 1OST-6.9-(RPV)
SOV-1RC-103B	1	B	1	Globe	LS	6-2	A-2	QST	CSJ1	1OST-1.10-Stroke & Time Open (CSD) 1OST-6.9-(RPV)
SOV-1RC-104	1	B	1	Globe	LS	6-2	A-3	QST	CSJ1	1OST-1.10-Stroke & Time Open (CSD) 1OST-6.9-(RPV)
SOV-1RC-105	1	B	1	Globe	LS	6-2	B-2	QST	CSJ1	1OST-1.10-Stroke & Time Open (CSD) 1OST-6.9-(RPV)
1RC-277	2	A/P	1/8	Needle	S	6-2	F-10	LT	RR1	1BVT 1.47.5-Leak Test (R)
1RC-278	2	A/P	1/8	Globe	S	6-2	E-10	LT	RR1	1BVT 1.47.5-Leak Test (R)
PCV-1RC-455C	1	B	3	Plug	A	6-2	B-10	QST	CSJ2	1OST-6.8-Stroke & Time Open (CSD) (RPV)
PCV-1RC-455D	1	B	3	Plug	A	6-2	C-10	QST	CSJ2	1OST-6.8-Stroke & Time Open (CSD) (RPV)
PCV-1RC-456	1	B	3	Plug	A	6-2	C-10	QST	CSJ2	1OST-1.10-Stroke & Time Open (CSD) (RPV)

BVPS-1 IST

VALVE TESTING OUTLINE

SYSTEM NAME: Reactor Coolant

SYSTEM NUMBER: 6

Valve Mark Number	Valve Class	Valve Category	Valve Size (in.)	Valve Type	NSA	Drawing		Test Requirement	CSJ or Relief Requests	Comments
						OM No	Coord.			
TV-1RC-519	2	A	3	Diaphragm	S	6-2	C-1	QST		1OST-47.3A(3B)-Stroke & Time Closed (Q),(RPV)
								LT	RR1	1BVT 1.47.5-Leak Test (R)
MOV-1RC-535	1	B	3	Gate	O	6-2	B-9	QST		1OST-6.6-Stroke & Time Closed (Q) 1OST-6.8-Stroke Only Closed (CSD) (RPV)
MOV-1RC-536	1	B	3	Gate	O	6-2	C-9	QST		1OST-6.6-Stroke & Time Closed (Q) 1OST-1.10-Stroke & Time Closed (CSD) (RPV)
MOV-1RC-537	1	B	3	Gate	O	6-2	C-9	QST		1OST-6.6-Stroke & Time Closed (Q) 1OST-6.8-Stroke Only Closed (CSD) (RPV)
RV-1RC-551A	1	C	6 x 6	Relief		6-2	C-6	SPT		1BVT 1.60.5-(R)
RV-1RC-551B	1	C	6 x 6	Relief		6-2	C-7	SPT		1BVT 1.60.5-(R)
RV-1RC-551C	1	C	6 x 6	Relief		6-2	C-8	SPT		1BVT 1.60.5-(R)

Beaver Valley Power Station

Unit 1

INSERVICE TESTING (IST) PROGRAM FOR PUMPS AND VALVES

Issue 2
Revision 8
Page 56 of 180

BVPS-1 IST VALVE TESTING OUTLINE											SYSTEM NUMBER
SYSTEM NAME: Chemical and Volume Control											7
Valve Mark Number	Valve Class	Valve Category	Valve Size (in)	Valve Type	NSA	Drawing		Test Requirement	CSJ or Relief Requests	Comments	
						OM No	Coord				
1CH-22	2	C	3	Check		7-1	C-3	QS		10ST-7.4-PS, FD (Q)	
								QS		10ST-7.5(6)-FS, RD (Q)	
								QS	RR4	10ST-11.14-FS, FD (R)	
1CH-23	2	C	3	Check		7-1	D-3	QS		10ST-7.5-PS,FD (Q)	
								QS		10ST-7.4(6)-FS, RD (Q)	
								QS	RR4	10ST-11.14-FS, FD (R)	
1CH-24	2	C	3	Check		7-1	E-3	QS		10ST-7.8-PS, FD (Q)	
								QS		10ST-7.4(5)-FS, RD (Q)	
1CH-25	2	B/P	3	Gate	LO	7-1	C-2	POS		10ST-11.14-FS, FD (R)	
1CH-26	2	B/P	3	Gate	LO	7-1	D-2	POS		Locked or sealed valve log	
1CH-27	2	B/P	3	Gate	LO	7-1	E-2	POS		Locked or sealed valve log	
1CH-31	2	A/C	3	Check		7-1	C-1	C3	RR5	1BVT 1.47.11-FS, RD by Leak Test (R)	
								LF		1BVT 1.47.11-Leak Test (R)	
1CH-75	3	C	2	Check		7-3	C-4	QS		10ST-7.1-PS, FD (Q)	
								QS	CSJ3	10ST-1.10-FS, FD (CSD)	

BVPS-1 IST
VALVE TESTING OUTLINE

SYSTEM NAME: Chemical and Volume Control

SYSTEM NUMBER 7

Valve Mark Number	Valve Class	Valve Category	Valve Size (in.)	Valve Type	NSA	Drawing		Test Requirement	CSJ or Relief Requests	Comments
						OM No	Coord			
1CH-78	3	C		Check		7-3	G-4	QS		1OST-7.2-PS, FD (Q)
								QS	CSJ3	1OST-1.10-FS, FD (CSD)
1CH-84	3	C	1	Check		7-3	E-7	QS	CSJ8	1OST-1.10-FS, FD (CSD)
FCV-1CH-113A	3	B	2	Globe	A	7-3	E-7	QST		1OST-47.3A(3B)-Stroke & Time Open (Q) (RPV)
MOV-1CH-115B	2	B	8	Gate	S	7-1	E-6	QST		1OST-47.3A(3B)-Stroke & Time Open (Q) (RPV)
MOV-1CH-115C	2	B	4	Gate	O	7-1	G-5	QST	CSJ4	1OST-1.10-Stroke & Time Closed (CSD) (RPV)
MOV-1CH-115D	2	B	8	Gate	S	7-1	E-6	QST		1OST-47.3A(3B)-Stroke & Time Open (Q) (RPV)
MOV-1CH-115E	2	B	4	Gate	O	7-1	F-5	QST	CSJ4	1OST-1.10-Stroke & Time Closed (CSD) (RPV)
1CH-135	3	B	1	Diaphragm	S	7-3	E-8	QS		1OST-47.3A(3B)-Stroke Only Open (Q)
1CH-136	3	C	1	Check		7-3	F-8	QS	CSJ9	1OST-1.10-FS, FD (CSD)
1CH-141	2	C	2	Check		7-3	G-8	QS	CSJ5	1OST-1.10-FS, FD (CSD)
MOV-1CH-142	2	A/P	2	Globe	S	7-1	A-9	LT	RR1	1BVT 1.47.5-Leak Test (R), (RPV)
1CH-152	2	C	2	Check		7-1	C-3	QS		1OST-7.4-FS, FD (Q)
								QS		1OST-7.5(6)-FS, RD (Q)
1CH-153	2	C	2	Check		7-1	D-3	QS		1OST-7.5-FS, FD (Q)
								QS		1OST-7.4(6)-FS, RD (Q)

Beaver Valley Power Station
Unit 1
INSERVICE TESTING (IST) PROGRAM FOR PUMPS AND VALVES

BVPS-1 IST VALVE TESTING OUTLINE												SYSTEM NUMBER 7
SYSTEM NAME: Chemical and Volume Control												Comments
Valve Mark Number	Valve Class	Valve Category	Valve Size (in.)	Valve Type	NSA	Drawing		Test Requirement	CSJ or Relief Requests			
						OM No	Coord					
1CH-154	2	C	2	Check		7-1	E-3	QS		1OST-7.6-FS, FD (Q)		
1CH-158	2	B/P	3	Gate	LO	7-1	C-3	POS		1OST-7.4(S)-FS, RD (Q)	Locked or sealed valve log	
1CH-159	2	B/P	3	Gate	LO	7-1	D-3	POS			Locked or sealed valve log	
FCV-1CH-160	2	A/P	2	Globe	S	7-1	G-3	LT		1BVT 1.47.11-Leak Test (R)		
1CH-161	2	B/P	3	Gate	LO	7-1	E-3	POS			Locked or sealed valve log	
1CH-170	1	A/C/P	2	Check		7-1	G-2	LT		1BVT 1.47.11-Leakage corrected for functional ΔP during leak test (R)		
1CH-181	2	A/C	2	Check		7-4	B-4	QS	RR6	1BVT 1.47.11-FS, RD by Leak Test (R)		
1CH-182	2	A/C	2	Check		7-4	D-4	QS	RR6	1BVT 1.47.11-FS, RD by Leak Test (R)		
1CH-183	2	A/C	2	Check		7-4	G-4	QS	RR6	1BVT 1.47.11-Leak Test (R)		
TC-1CH-200A	2	A	2	Globe	S	7-1	A-5	QST		1OST-47.5A(3)-Stroke & Time Closed (Q)(RPV)		
TC-1CH-200B	2	A	2	Globe	O	7-1	A-6	QST	RR1,RR7	1BVT 1.47.5-Leak Test (R)		
								LT		1OST-47.3A(3B)-Stroke & Time Closed (Q)(RPV)		
								LT	RR1,RR7	1BVT 1.47.5-Leak Test (R)		

BVPS-1 IST
VALVE TESTING OUTLINE

SYSTEM NAME: Chemical and Volume Control SYSTEM NUMBER: 7

Valve Mark Number	Valve Class	Valve Category	Valve Size (in)	Valve Type	NSA	Drawing		Test Requirement	CSJ or Relief Requests	Comments
						OM No	Coord			
TV-1CH-200C	2	A	2	Globe	S	7-1	A-7	QST		1OST-47.3A(3B)-Stroke & Time Closed (Q)(RPV)
								LT	RR1,RR7	1BVT 1.47.5-Leak Test (R)
RV-1CH-203	2	A/C	2 x 3	Relief		7-1	A-5	SPT		1BVT 1.60.5-(R)
								LT	RR1	1BVT 1.47.5-Leak Test (R)
TV-1CH-204	2	A	2	Gate	O	7-1	B-10	QST	CSJ6	1OST-1.10-Stroke & Time Closed (CSD)(RPV)
								LT	RR1	1BVT 1.47.5-Leak Test (R)
RV-1CH-209	2	C	2 x 3	Relief		7-1	D-10	SPT		1BVT 1.60.5-(R)
RV-1CH-257	2	C	3 x 4	Relief		7-3	B-8	SPT		1BVT 1.60.5-(R)
MOV-1CH-275A	2	B	2	Globe	O	7-1	C-3	QST		1OST-47.3A(3B)-Stroke & Time Closed (Q)(RPV)
MOV-1CH-275B	2	B	2	Globe	O	7-1	D-3	QST		1OST-47.3A(3B)-Stroke & Time Closed (Q)(RPV)
MOV-1CH-275C	2	B	2	Globe	O	7-1	E-3	QST		1OST-47.3A(3B)-Stroke & Time Closed (Q)(RPV)
MOV-1CH-289	2	A	3	Gate	O	7-1	D-1	QST	CSJ6	1OST-1.10-Stroke & Time Closed (CSD)(RPV)
								LT		1BVT 1.47.11-Leak Test (R)
MOV-1CH-308A	2	A	2	Globe	O	7-4	B-3	QST	RR10	1CST-1.10-Stroke & Time Closed (CSD)(RPV)
								LT		1BVT 1.47.11-Leak Test (R)
MOV-1CH-308B	2	A	2	Globe	O	7-4	D-3	QST	RR10	1OST-1.10-Stroke & Time Closed (CSD)(RPV)
								LT		1BVT 1.47.11-Leak Test (R)

Beaver Valley Power Station Unit 1 Issue 2
 INSERVICE TESTING (IST) PROGRAM FOR PUMPS AND VALVES Revision 8
 Page 60 of 180

BVP5-1 IST VALVE TESTING OUTLINE												SYSTEM NUMBER
SYSTEM NAME: Chemical and Volume Control												7
Valve Mark Number	Valve Class	Valve Category	Valve Size (in)	Valve Type	NSA	Drawing		Test Requirement	CSJ or Relief Requests	Comments		
						DM No	Coord					
MOV-1CH-308C	2	A	2	Globe	O	7-4	G-3	QST	RR10	1OST-1.10-Stroke & Time Closed (CSD)(RPV)		
								LT		1BVT 1.47.11-Leak Test (R)		
MOV-1CH-310	1	B	3	Gate	O	7-1	B-2	QST	CSJ7	1OST-1.10-Stroke & Time Closed (CSD)(RPV)		
MOV-1CH-350	3	B	2	Gate	S	7-3	G-7	QST		1OST-47.3A(3B)-Stroke & Time Oper. (Q)(RPV)		
1CH-309	2	A/C	3/4	Check		7-4	D-6	QS	RR8	1BVT 1.47.5-FS, RD by Leak Test (R)		
								LT	RR1, RR9	1BVT 1.47.5-Leak Test (R)		
MOV-1CH-370	2	B	3/4	Gate	O	7-4	B-1	QST	RR11	1OST-1.10-Stroke & Time Closed (CSD)(R)(RPV)		
MOV-1CH-377	2	B	3/4	Gate	O	7-4	E-9	QST	CSJ8	1OST-1.10-Stroke & Time Closed (CSD)(RPV)		
MOV-1CH-378	2	A	3/4	Gate	O	7-4	D-8	QST	RR12	1OST-1.10-Stroke & Time Closed (CSD)(R)(RPV)		
								LT	RR1, RR9	1BVT 1.47.5-Leak Test (R)		
MOV-1CH-381	2	A	3/4	Gate	O	7-4	F-8	QST	RR12	1OST-1.10-Stroke & Time Closed (CSD)(R)(RPV)		
								LT	RR1	1BVT 1.47.5-Leak Test (R)		
RV-1CH-382A	2	C	2 x 3	Relief		7-4	C-8	SPT		1BVT 1.60.5-(R)		
RV-1CH-382B	2	C	2 x 3	Relief		7-4	E-10	SPT		1BVT 1.60.5-(R)		
RV-1CH-383	2	C	3 x 4	Relief		7-1	C-2	SPT		1BVT 1.60.5-(R)		
LCV-1CH-460A	1	B	2	Globe	O	7-1	A-2	QST	CSJ7	1OST-1.10-Stroke & Time Closed (CSD)(RPV)		
LCV-1CH-460B	1	B	2	Globe	O	7-1	A-3	QST	CSJ7	1OST-1.10-Stroke & Time Closed (CSD)(RPV)		

**BVPS-2 IST
VALVE TESTING OUTLINE**

SYSTEM NAME: Reactor Plant Vents and Drains (Aerated)

SYSTEM NUMBER: 9

Valve Mark Number	Valve Class	Valve Category	Valve Size (in.)	Valve Type	NSA	Drawing		Test Requirement	CSJ or Relief Requests	Comments
						OM No.	Coord.			
TV-1DA-100A	2	A	2	Globe	A	9-1	G-4	QST		1OST-47.3A(3B)-Stroke & Time Closed (Q)(RPV)
								LT	RR1	1BVT 1.47.5-Leak Test (R)
TV-1DA-100B	2	A	2	Globe	O	9-1	G-4	QST		1OST-47.3A(3B)-Stroke & Time Closed (Q)(RPV)
								LT	RR1	1BVT 1.47.5-Leak Test (R)

BVPS-1 IST
VALVE TESTING OUTLINE

SYSTEM NAME: Reactor Plant Vents and Drains (Non-Aerated)						SYSTEM NUMBER: 9				
Valve Mark Number	Valve Class	Valve Category	Valve Size (in)	Valve Type	NSA	Drawing		Test Requirement	CSJ or Relief Requests	Comments
						OM No	Coord.			
TV-1DG-108A	2	A	2	Globe	O	9-1	F-9	QST		1OST-47.3A(3B)-Stroke & Time Closed (Q)(RPV)
								LT	RR1	1BVT 1.47.5-Leak Test (R)
TV-1DG-108B	2	A	2	Globe	O	9-1	F-10	QST		1OST-47.3A(3B)-Stroke & Time Closed (Q)(RPV)
								LT	RR1	1BVT 1.47.5-Leak Test (R)
TV-1DG-109A1	2	A	1 1/2	Globe	A	9-1	E-9	QST		1OST-47.3A(3B)-Stroke & Time Closed (Q)(RPV)
								LT	RR1	1BVT 1.47.5-Leak Test (R)
TV-1DG-109A2	2	A	1 1/2	Globe	A	9-1	E-8	QST		1OST-47.3A(3B)-Stroke & Time Closed (Q)(RPV)
								LT	RR1	1BVT 1.47.5-Leak Test (R)

BVPS-2 IST
VALVE TESTING OUTLINE

SYSTEM NAME: Residual Heat Removal SYSTEM NUMBER: 10

Valve Mark Number	Valve Class	Valve Category	Valve Size (in)	Valve Type	NSA	Drawing		Test Requirement	CSJ or Relief Request:	Comments
						OM No	Coord			
1RH-3	2	C	10	Check		10-1	E-3	QS	CSJ10	1OST-10.1-FS,FD,RD (CSD)
1RH-4	2	C	10	Check		10-1	F-3	QS	CSJ10	1OST-10.1-FS,FD,RD (CSD)
1RH-14	2	A/P	6	Gate	S	10-1	D-8	LT	RR1	1BVT 1.47.5-Leak Test (R)
1RH-15	2	A/P	6	Gate	S	10-1	B-8	LT	RR1	1BVT 1.47.5-Leak Test (R)
1RH-16	2	A/P	4	Ball	S	10-1	C-9	LT	RR1	1BVT 1.47.5-Leak Test (R)
MOV-1RH-700	1	A	14	Gate	S	10-1	F-1	QST	CSJ11	1OST-10.4-Stroke & Time Open (CSD)(RPV)
								LM		1OST-10.5-Leakage Monitoring (R)
MOV-1RH-701	1	A	14	Gate	S	10-1	F-2	QST	CSJ11	1OST-10.4-Stroke & Time Open (CSD)(RPV)
								LM		1OST-10.5-Leakage Monitoring (R)
MOV-1RH-720A	1	A	10	Gate	S	10-1	C-9	QST	CSJ11	1OST-10.4-Stroke & Time Open (CSD)(RPV)
								LM		Continuous Monitoring of RHR System Pressure
MOV-1RH-720B	1	A	10	Gate	S	10-1	D-9	QST	CSJ11	1OST-10.4-Stroke & Time Open (CSD)(RPV)
								LM		Continuous Monitoring of RHR System Pressure
RV-1RH-721	2	C	10	Ball		10-1	D-1			1BVT 1.60.5 (R)

Beaver Valley Power Station Unit 1
INSERVICE TESTING (IST) PROGRAM FOR PUMPS AND VALVES

INSERVICE TESTING (IST) PROGRAM FOR PUMPS AND VALVES

BVPS-2 IST VALVE TESTING OUTLINE										SYSTEM NUMBER: 11	
SYSTEM NAME: Safety Injection	Valve Mark Number	Valve Class	Valve Category	Valve Size (in.)	Valve Type	NSA	Drawing		Test Requirement	CSJ or Relief Requests	Comments
							OM No.	Coord.			
	1SI-1	2	C	12	Check		11-1	G-3	QS	RR13	Sample Disassembly and Inspection per 1CMP-75-ALOYCO-CHECK-1M(R)
	1SI-2	2	C	12	Check		11-1	G-3	QS	RR13	Sample Disassembly and Inspection per 1CMP-75-ALOYCO-CHECK-1M(P)
	1SI-5	2	C	12	Check		11-1	G-2	QS		1OST-11.1(2)-PS,FD (Q)
	1SI-6	2	C	10	Check		11-1	E-2	QS	RR14	1OST-11.14-FS,FD (R)
	1SI-7	2	C	10	Check		11-1	E-4	QS	RR15	1OST-11.1 FS,FD (Q)
	1SI-10	1	A/C	6	Check		11-1	D-8	QS	RR15	1OST-11.2-PS,FD (Q)
	1SI-11	1	A/C	6	Check		11-1	D-8	QS	RR16	1OST-11.16-FS,FD by Leak Test (R)
									LT	RR16	1OST-11.14-FS,FD (R)
									LT		1OST-11.16-Leak Test (R)
									QS	RR16	1OST-11.16-FS,FD by Leak Test (R)
									QS	RR16	1OST-11.14-FS,FD (R)
									LT		1OST-11.16-Leak Test (R)

BVPS-2 IST
VALVE TESTING OUTLINE

SYSTEM NAME: Safety Injection

SYSTEM NUMBER: 11

Valve Mark Number	Valve Class	Valve Category	Valve Size (in.)	Valve Type	NSA	Drawing		Test Requirement	CSJ or Relief Requests	Comments
						OM No.	Coord.			
1SI-12	1	A/C	6	Check		11-1	C-8	QS	RR16	1OST-11.16-FS, RD by Leak Test (R)
								QS	RR16	1OST-11.14-FS, FD (R)
								LT		1OST-11.16-Leak Test (R)
1SI-13	2	A/C/P	6	Check		11-1	F-7	LT		1BVT 1.47.11-Leak Test (R)
1SI-14	2	A/C/P	6	Check		11-1	F-7	LT		1BVT 1.47.11-Leak Test (R)
1SI-15	1	A/C/P	6	Check		11-1	F-9	LT		1OST-11.19-Leak Test (R)
1SI-16	1	A/C/P	6	Check		11-1	F-9	LT		1OST-11.19-Leak Test (R)
1SI-17	1	A/C/P	6	Check		11-1	F-9	LT		1OST-11.19-Leak Test (R)
1SI-20	1	C	6	Check		11-1	F-10	QS	RR17	1OST-11.14-FS, FD (R)
1SI-21	1	C	6	Check		11-1	F-10	QS	RR17	1OST-11.14-FS, FD (R)
1SI-22	1	C	6	Check		11-1	F-10	QS	RR17	1OST-11.14-FS, FD (R)
1SI-23	1	A/C	6	Check		11-1	C-10	QS	RR18	1OST-11.16-FS, RD by Leak Test (R)
								QS	RR18	1OST-11.14-FS, FD (R)
								LT		1OST-11.16-Leak Test (R)
1SI-24	1	A/C	6	Check		11-1	D-10	QS	RR18	1OST-11.16-FS, RD by Leak Test (R)
								QS	RR18	1OST-11.14-FS, FD (R)
								LT		1OST-11.16-Leak Test (R)

Beaver Valley Power Station
 Unit 1
 INSERVICE TESTING (IST) PROGRAM FOR PUMPS AND VALVES

Issue 2
 Revision 8
 Page 66 of 180

SYSTEM NAME: Safety Injection										SYSTEM NUMBER: 11		
BVPS-2 IST										VALVE TESTING OUTLINE		
Valve Mark Number	Valve Class	Valve Category	Valve Size (in)	Valve Type	NSA	Drawing		Test Requirement	CSJ or Relief Requests	Comments		
						OM No.	Coord.					
1SI-25	1	A/C	6	Check		11-1	D-10	QS	RR18	1OST-11.16-FS, RD by Leak Test (R)		
								QS	RR18	1OST-11.14-FS, FD (R)		
								LT		1OST-11.16-Leak Test (R)		
1SI-27	2	C	6	Check		11-1	G-1	QS	RR19	1OST-7.4,5 or 6-PS, FD(Q) if RWST is supplying charging pumps.		
								QS	RR19	1OST-11.14-FS, FD (R)		
1SI-28	2	C	2	Check		11-1	F-4	QS		1OST-11.1-FS, RD (Q)		
								QS		1OST-11.2-FS, FD (Q)		
1SI-29	2	C	2	Check		11-1	F-2	QS		1OST-11.1-FS, FD (Q)		
								QS		1OST-11.2-FS, FD (Q)		
1SI-41	2	A/P	1	Globe	LS	11-2	D-6	POS		Locked or sealed valve log		
								LT	RR1	1OST-11.47.5-Leak Test (R)		
1SI-42	2	A/CIP	1	Check		11-2	D-5	LT	RR1	1BVT 1.47.5-Leak Test (R)		
1SI-48	1	A/C	12	Check		11-2	C-2	QS	RR20	1BVT 1.11.3-FS, FD (R)		
								LT		1OST-11.4B-Leak Test (R)		
1SI-49	1	A/C	12	Check		11-2	E-2	QS	RR20	1BVT 1.11.3-FS, FD (R)		
								LT		1OST-11.4B-Leak Test (R)		

BVPDS-2 IST VALVE TESTING OUTLINE											SYSTEM NUMBER
SYSTEM NAME: Safety Injection											11
Valve Mark Number	Valve Class	Valve Category	Valve Size (in)	Valve Type	NSA	Drawing		Test Requirement	CSJ or Relief Requests	Comments	
						OM No	Coord				
1SI-50	1	A/C	12	Check		11-2	G-2	QS	RR20	1BVT 1.11.3-FS,FD (R)	
1SI-51	1	A/C	12	Check		11-2	C-2	QS	RR20	1OST-11.4B-Leak Test (R)	
1SI-52	1	A/C	12	Check		11-2	E-2	QS	RR20	1BVT 1.11.3-F ² ,FD (R)	
1SI-53	1	A/C	12	Check		11-2	G-2	QS	RR20	1OST-11.4A-Leak Test (R)	
1SI-83	1	A/C	3	Check		11-1	E-7	QS	RR21	1OST-11.14-FS,FD (R)	
1SI-84	1	A/C	3	Check		11-1	F-7	QS	RR21	1BVT 1.47.11-Leak Test (R)	
1SI-94	2	A/C	3	Check		11-1	B-7	QS	RR22	1OST-11.14-FS,FD (R)	
1SI-95	2	A/C	3	Check		11-1	A-7	QS	RR22	1BVT 1.47.11-Leak Test (R)	
1SI-100	1	C	2	Check		11-1	A-9	QS	RR17	1OST-11.14-FS,FD (R)	

BVPS-2 IST
VALVE TESTING OUTLINE

SYSTEM NAME: Safety Injection SYSTEM NUMBER 11

Valve Mark Number	Valve Class	Valve Category	Valve Size (in.)	Valve Type	NSA	Drawing		Test Requirement	CSJ or Relief Requests	Comments
						OM No.	Coord.			
1SI-101	1	C	2	Check		11-1	A-9	QS	RR17	1OST-11.14-FS,FD (R)
TV-1SI-101-1	2	A	1	Globe	S	11-2	B-6	QST		1OST-47.3A(3B)-Stroke & Time Closed (Q)(RPV)
								LT	RR1	1BVT 1.47.5-Leak Test (R)
TV-1SI-101-2	2	A	1	Globe	S	11-2	B-5	QST		1OST-47.3A(3B)-Stroke & Time Closed (Q)(RPV)
								LT	RR1	1BVT 1.47.5-Leak Test (R)
1SI-102	1	C	2	Check		11-1	B-9	QS	RR17	1OST-11.14-FS,FD (R)
1SI-447	2	B/P	3/4	Globe	LO	11-1	F-3	POS		Locked or sealed valve log
1SI-448	2	B/P	3/4	Globe	LO	11-1	F-3	POS		Locked or sealed valve log
1SI-451	2	B/P	3/4	Globe	LO	11-1	F-3	POS		Locked or sealed valve log
1SI-452	2	B/P	3/4	Globe	LO	11-1	F-3	POS		Locked or sealed valve log
MOV-1SI-836	2	A	3	Gate	S	11-1	A-6	QST	CSJ12	1OST-1.10-Stroke & Time Closed (CSD)(RPV)
								LT		1BVT 1.47.11-Leak Test (R)
MOV-1SI-842	2	A	2	Globe	S	11-2	E-5	QST		1OST-47.3A(3B)-Stroke & Time Closed (Q)(RPV)
								LT	RR1	1BVT 1.47.5-Leak Test (R)
RV-1SI-845A	2	C	3/4 x 1	Relief		11-1	D-2	SPT		1BVT 1.60.5-(R)
RV-1SI-845B	2	C	3/4 x 1	Relief		11-1	D-2	SPT		1BVT 1.60.5-(R)
RV-1SI-845C	2	C	3/4 x 1	Relief		11-1	D-4	SPT		1BVT 1.60.5-(R)

**BVPS-2 IST
VALVE TESTING OUTLINE**

SYSTEM NAME: Safety Injection						SYSTEM NUMBER: 11				
Valve Mark Number	Valve Class	Valve Category	Valve Size (in.)	Valve Type	NSA	Drawing		Test Requirement	CSJ or Relief Requests	Comments
						OM No.	Coord.			
RV-1SI-857	2	C	¾ x 1	Relief		11-1	B-6	SPT		1BVT 1.60.5-(R)
RV-1SI-858A	2	C	1 x 2	Relief		11-2	A-2	SPT		1BVT 1.60.5-(R)
RV-1SI-858B	2	C	1 x 2	Relief		11-2	C-2	SPT		1BVT 1.60.5-(R)
RV-1SI-858C	2	C	1 x 2	Relief		11-2	E-2	SPT		1BVT 1.60.5-(R)
MOV-1SI-860A	2	A	12	Gate	S	11-1	F-3	QST	CSJ13	1OST-1.10-Stroke & Time Open (CSD)(RPV)
								LT		1BVT 1.47.11-Leak Test (R)
MOV-1SI-860B	2	A	12	Gate	S	11-1	F-3	QST	CSJ13	1OST-1.10-Stroke & Time Open (CSD)(RPV)
								LT		1BVT 1.47.11-Leak Test (R)
MOV-1SI-862A	2	B	12	Gate	O	11-1	G-3	QST		1OST-47.3A(B)-Stroke & Time Closed (Q)(RPV)
MOV-1SI-862B	2	B	12	Gate	O	11-1	G-3	QST		1OST-47.3A(B)-Stroke & Time Closed (Q)(RPV)
MOV-1SI-863A	2	B	6	Gate	S	11-1	E-1	QST		1OST-47.3A(B)-Stroke & Time Open (Q)(RPV)
MOV-1SI-863B	2	B	6	Gate	S	11-1	E-5	QST		1OST-47.3A(B)-Stroke & Time Open (Q)(RPV)
MOV-1SI-864A	2	B	10	Gate	O	11-1	D-2	QST		1OST-47.3A(B)-Stroke & Time Open (Q)(RPV)
MOV-1SI-864B	2	B	10	Gate	O	11-1	D-4	QST		1OST-47.3A(B)-Stroke & Time Open (Q)(RPV)
MOV-1SI-865A	2	B/P	12	Gate	O	11-2	B-2	POS		1OM-54 Log L-5 (S) & OST-11.9 (M) 1BVT 1.11.3-(RPV)
MOV-1SI-865B	2	B/P	12	Gate	O	11-2	E-2	POS		1OM-54 Log L-5 (S) & OST-11.9 (M) 1BVT 1.11.3-(RPV)
MOV-1SI-865C	2	B/P	12	Gate	O	11-2	G-2	POS		1OM-54 Log L-5 (S) & OST-11.9 (M) 1BVT 1.11.3-(RPV)

Beaver Valley Power Station
 Unit 1
 INSERVICE TESTING (IST) PROGRAM FOR PUMPS AND VALVES

Issue 2
 Revision 8
 Page 70 of 180

BVPS-2 IST
VALVE TESTING OUTLINE

SYSTEM NAME: Safety Injection						SYSTEM NUMBER 11				
Valve Mark Number	Valve Class	Valve Category	Valve Size (in.)	Valve Type	NSA	Drawing		Test Requirement	CSJ or Relief Requests	Comments
						OM No	Coord.			
MOV-1SI-867A	2	B	3	Gate	S	11-1	A-2	QST	CSJ32	1OST-1.10-Stroke & Time Open (CSD)(RPV)
MOV-1SI-867B	2	B	3	Gate	S	11-1	A-2	QST	CSJ32	1OST-1.10-Stroke & Time Open (CSD)(RPV)
MOV-1SI-867C	2	A	3	Gate	S	11-1	B-6	QST	RR24	1OST-11.14-Stroke & Time Open (R)(RPV)
								LT		1BVT 1.47.11-Leak Test (R)
MOV-1SI-867D	2	A	3	Gate	S	11-1	B-6	QST	RR24	1OST-11.14-Stroke & Time Open (R)(RPV)
								LT		1BVT 1.47.11-Leak Test (R)
MOV-1SI-869A	2	A	3	Gate	S	11-1	E-6	QST	CSJ12	1OST-1.10-Stroke & Time Closed (CSD)(RPV)
								LT		1BVT 1.47.11-Leak Test (R)
MOV-1SI-869B	2	A	3	Gate	S	11-1	E-6	QST	CSJ14	1OST-1.10-Stroke & Time Closed (CSD)(RPV)
								LT		1BVT 1.47.11-Leak Test (R)
TV-1SI-884A	2	B	1	Globe	O	11-1	C-5	QST		1OST-47.3A(3B)-Stroke & Time Closed (Q)(RPV)
TV-1SI-884B	2	B	1	Globe	O	11-1	C-5	QST		1OST-47.3A(3B)-Stroke & Time Closed (Q)(RPV)
TV-1SI-884C	2	B	1	Globe	O	11-1	C-4	QST		1OST-47.3A(3B)-Stroke & Time Closed (Q)(RPV)
MOV-1SI-885A	2	B	2	Globe	O	11-1	F-4	QST		1OST-47.3A(3B)-Stroke & Time Closed (Q)(RPV)
MOV-1SI-885B	2	B	2	Globe	O	11-1	F-4	QST		1OST-47.3A(3B)-Stroke & Time Closed (Q)(RPV)
MOV-1SI-885C	2	B	2	Globe	O	11-1	F-5	QST		1OST-47.3A(3B)-Stroke & Time Closed (Q)(RPV)
MOV-1SI-885D	2	B	2	Globe	O	11-1	F-5	QST		1OST-47.3A(3B)-Stroke & Time Closed (Q)(RPV)

BVPS-2 IST
VALVE TESTING OUTLINE

SYSTEM NAME: Safety Injection

SYSTEM NUMBER 11

Valve Mark Number	Valve Class	Valve Category	Valve Size (in.)	Valve Type	NSA	Drawing		Test Requirement	CSJ or Relief Requests	Comments
						OM No.	Coord.			
TV-1SI-889	2	A	3/4	Gate	S	11-1	G-8	QST		1OST-47.3A(3B)-Stroke & Time Closed (CSD)(RPV)
								LT	RR1	1BVT 1.47.5-Leak Test (R)
MOV-1SI-890A	2	A/P	10	Gate	S	11-1	D-3	LT		1BVT 1.47.11-Leak Test (R)(RPV)
MOV-1SI-890B	2	A/P	10	Gate	S	11-1	D-5	LT		1BVT 1.47.11-Leak Test (R)(RPV)
MOV-1SI-890C	2	A	10	Gate	C	11-1	D-6	QST	CSJ15	1OST-1.10-Stroke & Time Open (CSD)(RPV)
								LT		1BVT 1.47.11-Leak Test (R)

BVP-1 IST VALVE TESTING OUTLINE												SYSTEM NUMBER
SYSTEM NAME: Containment Vacuum												12
Valve Mark Number	Valve Class	Valve Category	Valve Size (in.)	Valve Type	NSA	Drawing		Test Requirement	CSJ or Relief Requests	Comments		
						OM No.	Coord					
TV-1CV-101A	2	A	1	Globe	O	12-1	D-6	QST		1OST-47.3A(B) Stroke & Time Closed (Q)(RPV)		
TV-1CV-101B	2	A	1	Globe	O	12-1	D-7	QST	RR1	1BVT 1.47.5-Leak Test (R)		
TV-1CV-102	2	A	1	Globe	O	12-1	E-7	QST	RR1	1OST-47.3A(B) Stroke & Time Closed (Q)		
TV-1CV-102-1	2	A	1	Globe	O	12-1	E-8	QST	RR1	1BVT 1.47.5-Leak Test (R)(RPV)		
TV-1CV-150A	2	A	2	Globe	O	12-1	F-6	QST		1OST-47.3A(B) Stroke & Time Closed (Q)		
TV-1CV-150B	2	A	2	Globe	S	12-1	F-7	QST	RR1,RR40	1BVT 1.47.5-Leak Test (R)(RPV)		
TV-1CV-150C	2	A	2	Globe	O	12-1	E-7	QST	RR1,RR40	1OST-47.3A(B) Stroke & Time Closed (Q)		
TV-1CV-150D	2	A	2	Globe	S	12-1	E-6	QST	RR1,RR41	1BVT 1.47.5-Leak Test (R)(RPV)		
HCV-1CV-151	2	A/P	6	Butterfly	LS	12-1	F-8	LT	RR1	1OST-47.3A(B) Stroke & Time Closed (Q)		
								LT		1BVT 1.47.5-Leak Test (R)(RPV)		
								LT		1BVT 1.47.5-Leak Test (R)		

BVPS-1 IST
VALVE TESTING OUTLINE

SYSTEM NAME: Containment Vacuum

SYSTEM NUMBER: 12

Valve Mark Number	Valve Class	Valve Category	Valve Size (in)	Valve Type	NSA	Drawing		Test Requirement	CSJ or Relief Requests	Comments
						GM No.	Coord.			
HCV-1CV-151-1	2	A/P	8	Butterfly	LS	12-1	F-1	LT	RR1	1BVT 1 475-Leak Test (R)

BVPS-1 IST
VALVE TESTING OUTLINE

SYSTEM NAME: Leakage Monitoring

SYSTEM NUMBER: 12

Valve Mark Number	Valve Class	Valve Category	Valve Size (in.)	Valve Type	NSA	Drawing		Test Requirement	CSJ or Relief Requests	Comments
						OM No.	Coord			
TV-1LM-100A1	1	A	3/8	Globe	S	12-1	B-2	QST		1QST-47.3A(B)-Stroke & Time Closed (Q)(RPV)
								LT	RR1	1BVT 1.47.5-Leak Test (R)
TV-1LM-100A2	2	A	3/8	Globe	S	12-1	B-3	QST		1QST-47.3A(B)-Stroke & Time Closed (Q)(RPV)
								LT	RR1	1BVT 1.47.5-Leak Test (R)

BVPS-1 IST
VALVE TESTING OUTLINE

SYSTEM NAME: Containment Depressurization (Quench Spray)						SYSTEM NUMBER 13				
Valve Mark Number	Valve Class	Valve Category	Valve Size (in.)	Valve Type	NSA	Drawing		Test Requirement	CSJ or Relief Requests	Comments
						OM No	Coord			
1QS-3	2	A/C	10	Check		13-1	B-4	QS	CSJ/16	10ST-1.10-F5,FD by Mechanical Exerciser (CSD)
								LT	RR1	1BVT 1.47.5-Leak Test (R)
1QS-4	2	A/C	10	Check		13-1	A-4	QS	CSJ/16	10ST-1.10-F5,FD by Mechanical Exerciser (CSD)
								LT	RR1	1BVT 1.47.5-Leak Test (R)
MOV-1QS-100A	2	B	12	Gate	O	13-1	D-6	QST		10ST-47.3A(3B)-Stroke & Time Open (Q)(RPV)
MOV-1QS-100B	2	B	12	Gate	O	13-1	D-6	QST		10ST-47.3A(3B)-Stroke & Time Open (Q)(RPV)
RV-1QS-100A	2	C	1 1/2 x 2 1/2	Relief		13-1	F-10	SPT		1BVT 1.60.5-(R)
RV-1QS-100B	2	C	1 1/2 x 2 1/2	Relief		13-1	F-9	SPT		1BVT 1.60.5-(R)
MOV-1QS-101A	2	A	10	Gate	S	13-1	B-5	QST		10ST-47.3A(3B)-Stroke & Time Open (Q)(RPV)
								LT	RR1	1BVT 1.47.5-Leak Test (R)
MOV-1QS-101B	2	A	10	Gate	S	13-1	A-6	QST		10ST-47.3A(3B)-Stroke & Time Open (Q)(RPV)
								LT	RR1	1BVT 1.47.5-Leak Test (R)
MOV-1QS-103A	2	B	10	Gate	O	13-1	C-5	QST		10ST-47.3A(3B)-Stroke & Time Closed (Q)(RPV)
MOV-1QS-103B	2	B	10	Gate	O	13-1	C-6	QST		10ST-47.3A(3B)-Stroke & Time Closed (Q)(RPV)
MOV-1QS-104A	2	B	3	Diaphragm	S	13-1	E-9	QST		10ST-13.10A-Stroke & Time Open (Q)(RPV)
MOV-1QS-104B	2	B	3	Diaphragm	S	13-1	E-8	QST		10ST-13.10B-Stroke & Time Open (Q)(RPV)

Beaver Valley Power Station
 Unit 1
 INSERVICE TESTING (IST) PROGRAM FOR PUMPS AND VALVES
 Issue 2
 Revision 8
 Page 76 of 180

**BVPS-1 IST
VALVE TESTING OUTLINE**

SYSTEM NAME: Containment Depressurization (Quench Spray)

SYSTEM NUMBER: 10

Valve Mark Number	Valve Class	Valve Category	Valve Size (in.)	Valve Type	KSA	Drawing		Test Requirement	CSJ or Relief Requests	Comments
						OM No	Coord			
1RS-100	2	A/C	10	Check		13-1	D-4	QS	CSJ16	10ST-1.10-FS,FD by Mechanical Exerciser (CSD)
								LT	RR1	1BVT 1.47.5-Leak Test (R)
1RS-101	2	A/C	10	Check		13-1	C-4	QS	CSJ16	10ST-1.10-FS,FD by Mechanical Exerciser (CSD)
								LT	RR1	1BVT 1.47.5-Leak Test (R)
MOV-1RS-155A	2	B	12	Gate	O	13-1	G-5	QST		10ST-47.3A(3B)-Stroke & Time Open (Q)(RPV)
MOV-1RS-155B	2	B	12	Gate	O	13-1	G-7	QST		10ST-47.3A(3B)-Stroke & Time Open (Q)(RPV)
MOV-1RS-156A	2	B	10	Gate	O	13-1	E-5	QST		10ST-47.3A(3B)-Stroke & Time Open (Q)(RPV)
MOV-1RS-156B	2	B	10	Gate	O	13-1	E-5	QST		10ST-47.3A(3B)-Stroke & Time Open (Q)(RPV)
1RS-157	2	B	6	Gate	LS	13-1	E-6	QS		10ST-47.3A(3B)-Stroke Only Open (Q)
1RS-158	2	C	6	Check		13-1	E-6	QS	RR25	Sample Disassembly and inspection per CMP 1/2-75-VELAN CHECK-1M (R)
1RS-159	2	B	6	Gate	LS	13-1	E-7	QS		10ST-47.3A(3B)-Stroke Only Open (Q)
1RS-160	2	C	6	Check		13-1	E-7	QS	RR25	Sample Disassembly and inspection per CMP 1/2-75-VELAN CHECK-1M (R)

BVPS-1 IST
VALVE TESTING OUTLINE

SYSTEM NAME: Reactor Plant Sample

SYSTEM NUMBER 14A

Valve Mark Number	Valve Class	Valve Category	Valve Size (in.)	Valve Type	NSA	Drawing		Test Requirement	CSJ or Relief Requests	Comments
						OM No.	Coord.			
TV-1SS-100A1	2	A	3/4	Globe	O	14A-1	D-3	QST		1OST-47.3A(3B)-Stroke & Time Closed (Q)(RPV)
								LT	RR1	1BVT 1.47.5-Leak Test (R)
TV-1SS-100A2	2	A	3/4	Globe	O	14A-1	D-3	QST		1OST-47.3A(3B)-Stroke & Time Closed (Q)(RPV)
								LT	RR1	1BVT 1.47.5-Leak Test (R)
TV-1SS-102A1	2	A	3/4	Globe	O	14A-1	A-3	QST		1OST-47.3A(3B)-Stroke & Time Closed (Q)
								LT	RR1	1BVT 1.47.5-Leak Test (R)(RPV)
TV-1SS-102A2	2	A	3/4	Globe	O	14A-1	A-3	QST		1OST-47.3A(3B)-Stroke & Time Closed (Q)
								LT	RR1	1BVT 1.47.5-Leak Test (R)(RPV)
TV-1SS-103A1	2	A	3/4	Globe	O	14A-1	D-3	QST		1OST-47.3A(3B)-Stroke & Time Closed (Q)(RPV)
								LT	RR1	1BVT 1.47.5-Leak Test (R)
TV-1SS-103A2	2	A	3/4	Globe	O	14A-1	D-3	QST		1OST-47.3A(3B)-Stroke & Time Closed (Q)(RPV)
								LT	RR1	1BVT 1.47.5-Leak Test (R)
TV-1SS-104A1	2	A	3/4	Globe	O	14A-1	C-3	QST		1OST-47.3A(3B)-Stroke & Time Closed (Q)(RPV)
								LT	RR1	1BVT 1.47.5-Leak Test (R)
TV-1SS-104A2	2	A	3/4	Globe	O	14A-1	C-3	QST		1OST-47.3A(3B)-Stroke & Time Closed (Q)(RPV)
								LT	RR1	1BVT 1.47.5-Leak Test (R)

**BVPS-1 IST
VALVE TESTING OUTLINE**

SYSTEM NAME: Reactor Plant Sample

SYSTEM NUMBER 14A

Valve Mark Number	Valve Class	Valve Category	Valve Size (in.)	Valve Type	NSA	Drawing		Test Requirement	CSJ or Relief Requests	Comments
						OM No.	Coord.			
TV-1SS-105A1	2	A	3/4	Globe	O	14A-1	B-3	QST		1OST-47.3A(3B)-Stroke & Time Closed (Q)
								LT	RR1	1BVT 1.47.5-Leak Test (R)(RPV)
TV-1SS-105A2	2	A	3/4	Globe	O	14A-1	B-3	QST		1OST-47.3A(3B)-Stroke & Time Closed (Q)
								LT	RR1	1BVT 1.47.5-Leak Test (R)(RPV)
TV-1SS-109A1	2	A	3/4	Globe	O	14A-1	E-3	QST		1OST-47.3A(3B)-Stroke & Time Closed (Q)(RPV)
								LT	RR1	1BVT 1.47.5-Leak Test (R)
TV-1SS-109A2	2	A	3/4	Globe	O	14A-1	E-3	QST		1OST-47.3A(3B)-Stroke & Time Closed (Q)(RPV)
								LT	RR1	1BVT 1.47.5-Leak Test (R)
TV-1SS-111A1	2	A	3/4	Globe	O	14A-1	D-3	QST		1OST-47.3A(3B)-Stroke & Time Closed (Q)(RPV)
								LT	RR1	1BVT 1.47.5-Leak Test (R)
TV-1SS-111A2	2	A	3/4	Globe	O	14A-1	D-3	QST		1OST-47.3A(3B)-Stroke & Time Closed (Q)(RPV)
								LT	RR1	1BVT 1.47.5-Leak Test (R)
TV-1SS-112A1	2	A	3/4	Globe	O	14A-1	E-3	QST		1OST-47.3A(3B)-Stroke & Time Closed (Q)(RPV)
								LT	RR1	1BVT 1.47.5-Leak Test (R)
TV-1SS-112A2	2	A	3/4	Globe	O	14A-1	E-3	QST		1OST-47.3A(3B)-Stroke & Time Closed (Q)(RPV)
								LT	RR1	1BVT 1.47.5-Leak Test (R)
TV-1SS-117A	2	B	3/4	Globe	O	14A-1	G-2	QST		1OST-47.3A(3B)-Stroke & Time Closed (Q)(RPV)

BVP-S-1 IST VALVE TESTING OUTLINE										SYSTEM NUMBER
SYSTEM NAME: Reactor Plant Sample										14A
Valve Mark Number	Valve Class	Valve Categor.	Valve Size (in.)	Valve Type	NSA	Drawing		Test Requirement	CSJ or Relief Requests	Comments
						OM No.	Coord			
TV-1SS-117B	2	B	3/4	Globe	O	14A-1	F-2	QST		10ST-47.3A(3B)- Stroke & Time Closed (Q)(RPV)
TV-1SS-117C	2	B	3/4	Globe	O	14A-1	F-2	QST		10ST-47.3A(3B)- Stroke & Time Closed (Q)(RPV)

**BVPS-1 IST
VALVE TESTING OUTLINE**

SYSTEM NAME: Reactor Plant Component Cooling Water

SYSTEM NUMBER 15

Valve Mark Number	Valve Class	Valve Category	Valve Size (in)	Valve Type	NSA	Drawing		Test Requirement	CSJ or Relief Requests	Comments
						OM No	Coord			
1CCR-4	3	C	18	Check		15-1	E-6	QS		1OST-15.1-FS,FD (Q)
								QS		1OST-15.2(3)-FS,RD (Q)
1CCR-5	3	C	18	Check		15-1	E-7	QS		1OST-15.2-FS,FD (Q)
								QS		1OST-15.1(3)-FS,RD (Q)
1CCR-6	3	C	18	Check		15-1	E-8	QS		1OST-15.3-FS,FD (Q)
								QS		1OST-15.1(2)-FS,RD (Q)
TV-1CC-103A	2	A	6	Globe	O	15-5	A-6	QST	RR26	1OST-1.10-Stroke & Time Closed (CSD)(R)(RPV)
								LT	RR1	1BVT 1.47.5-Leak Test (R)
TV-1CC-103A1	2	A	6	Globe	O	15-5	B-6	QST	RR26	1OST-1.10-Stroke & Time Closed (CSD)(R)(RPV)
								LT	RR1	1BVT 1.47.5-Leak Test (R)
TV-1CC-103B	2	A	6	Globe	O	15-5	A-4	QST	RR26	1OST-1.10-Stroke & Time Closed (CSD)(R)(RPV)
								LT	RR1	1BVT 1.47.5-Leak Test (R)
TV-1CC-103B1	2	A	6	Globe	O	15-5	B-4	QST	RR26	1OST-1.10-Stroke & Time Closed (CSD)(R)(RPV)
								LT	RR1	1BVT 1.47.5-Leak Test (R)
TV-1CC-103C	2	A	6	Globe	O	15-5	A-3	QST	RR26	1OST-1.10-Stroke & Time Closed (CSD)(R)(RPV)
								LT	RR1	1BVT 1.47.5-Leak Test (R)

Beaver Valley Power Station
Unit 1
INSERVICE TESTING (IST) PROGRAM FOR PUMPS AND VALVES

Issue 2
Revision 3
Page 61 of 180

BVPS-1 IST
VALVE TESTING OUTLINE

SYSTEM NAME: Reactor Plant Component Cooling Water						SYSTEM NUMBER: 15				
Valve Mark Number	Valve Class	Valve Category	Valve Size (in.)	Valve Type	NSA	Drawing		Test Requirement	CSJ or Relief Requests	Comments
						OM No.	Coord			
TV-1CC-103C1	2	A	6	Globe	O	15-5	B-3	QST	RR26	1OST-1.10-Stroke & Time Closed (CSD)(R)(RPV)
								LT	RR1	1BVT 1.47.5-Leak Test (R)
TV-1CC-105D1		A	6	Globe	O	15-5	F-6	QST	RR26	1OST-1.10-Stroke & Time Closed (CSD)(R)(RPV)
								LT	RR1	1BVT 1.47.5-Leak Test (R)
TV-1CC-105D2	2	A	6	Globe	O	15-5	G-6	QST	RR26	1OST-1.10-Stroke & Time Closed (CSD)(R)(RPV)
								LT	RR1	1BVT 1.47.5-Leak Test (R)
TV-1CC-105E1	2	A	4	Globe	O	15-5	F-5	QST	RR26	1OST-1.10-Stroke & Time Closed (CSD)(R)(RPV)
								LT	RR1	1BVT 1.47.5-Leak Test (R)
TV-1CC-105E2	2	A	4	Globe	O	15-5	G-5	QST	RR26	1OST-1.10-Stroke & Time Closed (CSD)(R)(RPV)
								LT	RR1	1BVT 1.47.5-Leak Test (R)
TV-1CC-107A	3	B	2	Globe	O	15-5	C-6	QST	RR26	1OST-1.10-Stroke & Time Closed (CSD)(R)(RPV)
TV-1CC-107B	3	B	2	Globe	O	15-5	D-6	QST	RR26	1OST-1.10-Stroke & Time Closed (CSD)(R)(RPV)
TV-1CC-107C	3	B	2	Globe	O	15-5	F-6	QST	RR26	1OST-1.10-Stroke & Time Closed (CSD)(R)(RPV)
TV-1CC-107D1	2	A	3	Globe	O	15-5	F-4	QST	RR26	1OST-1.10-Stroke & Time Closed (CSD)(R)(RPV)
								LT	RR1	1BVT 1.47.5-Leak Test (R)
TV-1CC-107D2	2	A	3	Globe	O	15-5	G-4	QST	RR26	1OST-1.10-Stroke & Time Closed (CSD)(R)(RPV)
								LT	RR1	1BVT 1.47.5-Leak Test (R)

BVPS-1 IST
VALVE TESTING OUTLINE

SYSTEM NAME						SYSTEM NUMBER				
Reactor Plant Component Cooling Water						15				
Valve Mark Number	Valve Class	Valve Category	Valve Size (in.)	Valve Type	NSA	Drawing		Test Requirement	CSJ or Relief Requests	Comments
						OM No	Coord.			
TV-1CC-107E1	2	A	2	Globe	O	15-5	F-3	QST	RR26	1OST-1.10-Stroke & Time Closed (CSD)(R)(RPV)
								LT	RR1	1BVT 1.47.5-Leak Test (R)
TV-1CC-107E2	2	A	2	Globe	O	15-5	G-3	QST	RR26	1OST-1.10-Stroke & Time Closed (CSD)(R)(RPV)
								LT	RR1	1BVT 1.47.5-Leak Test (R)
RV-1CC-109	3	C	¾ x 1	Relief		15-2	E-7	SPT		1BVT 1.60.5-(R)
RV-1CC-110	3	C	¾ x 1	Relief		15-2	E-6	SPT		1BVT 1.60.5-(R)
TV-1CC-110D	2	A	8	Globe	O	29-2	E-9	QST	CSJ19	1OST-1.10-Stroke & Time Closed (CSD)(RPV)
								LT	RR1	1BVT 1.47.5-Leak Test (R)
TV-1CC-110E2	2	A	8	Globe	O	29-2	A-2	QST	CSJ19	1OST-1.10-Stroke & Time Closed (CSD)(RPV)
								LT	RR1	1BVT 1.47.5-Leak Test (R)
TV-1CC-110E3	2	A	8	Globe	O	29-2	A-3	QST	CSJ19	1OST-1.10-Stroke & Time Closed (CSD)(RPV)
								LT	RR1	1BVT 1.47.5-Leak Test (R)
TV-1CC-110F1	2	A/P	8	Globe	S	29-2	E-10	LT	RR1,RR27	1BVT 1.47.5-Leak Test (R)(RPV)
TV-1CC-110F2	2	A	8	Globe	O	29-2	F-10	QST	CSJ19	1OST-1.10-Stroke & Time Closed (CSD)(RPV)
								LT	RR1	1BVT 1.47.5-Leak Test (R)
RV-1CC-111A	3	C	¾ x 1	Relief		15-2	B-6	SPT		1BVT 1.60.5-(R)

BVPS-1 IST VALVE TESTING OUTLINE										SYSTEM NUMBER 15
SYSTEM NAME	Reactor Plant Component Cooling Water									
Valve Mark Number	Valve Class	Valve Category	Valve Size (in)	Valve Type	NSA	Drawing		Test Requirement	CSJ or Relief Requests	Comments
						OM No	Coord			
TV-1CC-111A1	2	A	6	Globe	O	15-3	B-8	QST	CSJ17	10ST-1.10-Stroke & Time Closed (CSD)(RPV)
								LT	RR1	1BVT 1.47.5-Leak Test (R)
TV-1CC-111A2	2	A	6	Globe	O	15-3	B-8	QST	CSJ17	10ST-1.10-Stroke & Time Closed (CSD)(RPV)
								LT	RR1	1BVT 1.47.5-Leak Test (R)
RV-1CC-111B	3	C	1/2 x 1	Relief		15-2	B-6	SPT		1BVT 1.60.5-(R)
TV-1CC-111D1	2	A	6	Globe	O	15-3	F-4	QST	CSJ17	10ST-1.10-Stroke & Time Closed (CSD)(RPV)
								LT	RR1	1BVT 1.47.5-Leak Test (R)
TV-1CC-111D2	2	A	6	Globe	O	15-3	G-4	QST	CSJ17	10ST-1.10-Stroke & Time Closed (CSD)(RPV)
								LT	RR1	1BVT 1.47.5-Leak Test (R)
RV-1CC-112A	3	C	1/2 x 1	Relief		28-2	B-1	SPT		1BVT 1.60.5-(R)
RV-1CC-112A1	3	C	1/2 x 1	Relief		29-2	C-1	SPT		1BVT 1.60.5-(R)
MOV-1CC-112A2	2	A	18	Butterfly	S	15-5	A-7	QST		10ST-47.3A(3B)-Stroke & Time Open (Q)(RPV)
								LT	RR1	1BVT 1.47.5-Leak Test (R)
RV-1CC-112A2	3	C	1/2 x 1	Relief		29-2	E-1	SPT		1BVT 1.60.5-(R)
MOV-1CC-112A3	2	A	18	Butterfly	S	15-5	F-7	QST		10ST-47.3A(3B)-Stroke & Time Open (Q)(RPV)
								LT	RR1	1BVT 1.47.5-Leak Test (R)
RV-1CC-112B	3	C	1/2 x 1	Relief		28-2	B-4	SPT		1BVT 1.60.5-(R)

BVPS-1 IST VALVE TESTING OUTLINE												SYSTEM NUMBER
SYSTEM NAME: Reactor Plant Component Cooling Water												15
Valve Mark Number	Valve Class	Valve Category	Valve Size (in.)	Valve Type	NSA	Drawing		Test Requirement	CSJ or Relief Requests	Comments	SYSTEM NUMBER	
						OM No	Coord					
RV-1CC-112B1	3	C	1/2 x 1	Relief		29-2	D-4	SPT		1BVT 1.60.5-(R)		
MOV-1CC-112B2	2	A	18	Butterfly	S	15-5	A-8	QST		1OST-47.3A(3B) Stroke & Time Oper (Q)(RPV)		
RV-1CC-112B2	3	C	1/2 x 1	Relief		29-2	E-4	SPT		1BVT 1.47.5-Leak Test (R)		
MOV-1CC-112B3	2	A	18	Butterfly	S	15-5	F-8	QST		1OST-47.3A(3B) Stroke & Time Oper (Q)(RPV)		
RV-1CC-112C	3	C	1/2 x 1	Relief		29-2	B-6	SPT		1BVT 1.47.5-Leak Test (R)		
RV-1CC-112C1	3	C	1/2 x 1	Relief		29-2	D-6	SPT		1BVT 1.60.5-(R)		
RV-1CC-112C2	3	C	1/2 x 1	Relief		29-2	E-6	SPT		1BVT 1.60.5-(R)		
RV-1CC-113A	3	C	1/2 x 1	Relief		15-3	D-2	SPT		1BVT 1.60.5-(R)		
RV-1CC-113B	3	C	1/2 x 1	Relief		15-3	D-5	SPT		1BVT 1.60.5-(R)		
RV-1CC-113C	3	C	1/2 x 1	Relief		15-3	C-8	SPT		1BVT 1.60.5-(R)		
RV-1CC-115A	3	C	1/2 x 1	Relief		15-5	B-4	SPT		1BVT 1.60.5-(R)		
RV-1CC-115B	3	C	1/2 x 1	Relief		15-5	D-4	SPT		1BVT 1.60.5-(R)		
RV-1CC-115C	3	C	1/2 x 1	Relief		15-5	E-4	SPT		1BVT 1.60.5-(R)		
RV-1CC-116A	3	C	1/2 x 1	Relief		15-5	C-3	SPT		1BVT 1.60.5-(R)		
RV-1CC-116B	3	C	1/2 x 1	Relief		15-5	D-3	SPT		1BVT 1.60.5-(R)		

**BVPS-1 IST
VALVE TESTING OUTLINE**

SYSTEM NAME: Reactor Plant Component Cooling Water						SYSTEM NUMBER 15				
Valve Mark Number	Valve Class	Valve Category	Valve Size (in.)	Valve Type	NSA	Drawing		Test Requirement	CSJ or Relief Requests	Comments
						OM No	Coord.			
RV-1CC-116C	3	C	¾ x 1	Relief		15-5	E-3	SPT		1BVT 1.60.5-(R)
RV-1CC-117	3	C	¾ x 1	Relief		15-4	C-9	SPT		1BVT 1.60.5-(R)
RV-1CC-118	3	C	¾ x 1	Relief		15-4	C-9	SPT		1BVT 1.60.5-(R)
RV-1CC-119A	3	C	¾ x 1	Relief		15-5	C-7	SPT		1BVT 1.60.5-(R)
RV-1CC-119B	3	C	¾ x 1	Relief		15-5	E-8	SPT		1BVT 1.60.5-(R)
TV-1CC-121-1	3	B	2	Globe	O	15-4	B-1	QST		1OST-47.3A(3B)-Stroke & Time Closed (Q)(RPV)
TV-1CC-121-2	3	B	1	Globe	O	15-4	F-2	QST		1OST-47.3A(3B)-Stroke & Time Closed (Q)(RPV)
TV-1CC-125	3	B	3	Globe	O	15-2	A-3	QST		1OST-47.3A(3B)-Stroke & Time Closed (Q)(RPV)
TV-1CC-125-1	3	B	6	Globe	O	15-1	F-5	QST		1OST-47.3A(3B)-Stroke & Time Closed (Q)(RPV)
TV-1CC-125-2	3	B	6	Globe	O	15-1	F-5	QST		1OST-47.3A(3B)-Stroke & Time Closed (Q)(RPV)
TV-1CC-126	3	B	8	Globe	O	15-2	A-4	QST		1OST-47.3A(3B)-Stroke & Time Closed (Q)(RPV)
TV-1CC-126-1	3	B	8	Globe	O	15-1	G-7	QST		1OST-47.3A(3B)-Stroke & Time Closed (Q)(RPV)
TV-1CC-126-2	3	B	8	Globe	O	15-1	G-8	QST		1OST-47.3A(3B)-Stroke & Time Closed (Q)(RPV)
TV-1CC-127	3	B	8	Globe	O	15-2	D-5	QST		1OST-47.3A(3B)-Stroke & Time Closed (Q)(RPV)
TV-1CC-127-1	3	B	8	Globe	O	15-1	F-9	QST		1OST-47.3A(3B)-Stroke & Time Closed (Q)(RPV)
TV-1CC-127-2	3	B	8	Globe	O	15-1	E-9	QST		1OST-47.3A(3B)-Stroke & Time Closed (Q)(RPV)
TV-1CC-128	3	B	8	Globe	O	15-2	B-6	QST		1OST-47.3A(3B)-Stroke & Time Open (Q)(RPV)

BVPS-1 IST VALVE TESTING OUTLINE													SYSTEM NUMBER: 15
Reactor Plant Component Cooling Water													
SYSTEM NAME	Valve Mark Number	Valve Class	Valve Category	Valve Size (in.)	Valve Type	NSA	Drawing		Test Requirement	CSJ or Relief Requests	Comments	SYSTEM NUMBER: 15	
							OM No	Coord					
TV-1CC-129	3	B	6	Globe	O	15-2	A-10	QST	10ST-47.3A(3B)-Stroke & Time Closed (Q)(RPV)				
TV-1CC-129-1	3	B	6	Globe	O	15-2	B-10	QST	10ST-47.3A(3B)-Stroke & Time Closed (Q)(RPV)				
TV-1CC-129-2	3	B	6	Globe	O	15-2	E-10	QST	10ST-47.3A(3B)-Stroke & Time Closed (Q)(RPV)				
TV-1CC-130	3	B	6	Globe	O	15-2	E-6	QST	10ST-1.10-Stroke & Time Closed (CSD)(RPV)				
TV-1CC-132	3	B	3	Globe	O	15-2	E-7	QST	10ST-1.10-Stroke & Time Closed (CSD)(RPV)				
TV-1CC-133-2	3	B	1/4	Globe	O	15-2	G-9	QST	10ST-47.3A(3B)-Stroke & Time Closed (Q)(RPV)				
TV-1CC-133-3	3	B	6	Globe	O	15-2	F-10	QST	10ST-47.3A(3B)-Stroke & Time Closed (Q)(RPV)				
TV-1CC-134-1	3	B	1 1/2	Globe	O	15-2	A-7	QST	10ST-47.3A(3B)-Stroke & Time Closed (Q)(RPV)				
TV-1CC-134-2	3	B	1 1/2	Globe	O	15-2	B-7	QST	10ST-47.3A(3B)-Stroke & Time Closed (Q)(RPV)				
TV-1CC-134-5	3	B	1 1/2	Globe	O	15-2	G-8	QST	10ST-47.3A(3B)-Stroke & Time Closed (Q)(RPV)				
TV-1CC-136	3	B	12	Globe	O	15-2	A-5	QST	10ST-47.3A(3B)-Stroke & Time Closed (Q)(RPV)				
RV-1CC-136A	3	C	1/4 x 1	Relief		15-5	B-7	SPT	1BVT-1.60.5-(R)				
RV-1CC-136B	3	C	1/4 x 1	Relief		15-5	D-8	SPT	1BVT-1.60.5-(R)				
TV-1CC-137	3	B	2	Globe	O	15-5	B-1	QST	10ST-47.3A(3B)-Stroke & Time Closed (Q)(RPV)				
TV-1CC-137A	3	B	1 1/2	Globe	O	15-5	D-2	QST	10ST-47.3A(3B)-Stroke & Time Closed (Q)(RPV)				
TV-1CC-137B	3	B	1 1/2	Globe	S	15-5	E-1	QST	10ST-47.3A(3B)-Stroke & Time Closed (Q)(RPV)				
RV-1CC-139A	3	C	1/4 x 1	Relief		15-4	B-6	SPT	1BVT-1.60.5-(R)				

BVPS-1 IST VALVE TESTING OUTLINE												SYSTEM NUMBER
SYSTEM NAME: Reactor Plant Component Cooling Water												15
Valve Mark Number	Valve Class	Valve Category	Valve Size (in.)	Valve Type	NSA	Drawing		Test Requirement	CSJ or Relief Requests	Comments		
						OM No.	Coord					
RV-1CC-139B	3	C	3/4 x 1	Relief		15-4	B-6	SPT		1BVT 160.5-(R)		
RV-1CC-139C	3	C	3/4 x 1	Relief		15-4	L-6	SPT		1BVT 160.5-(R)		
RV-1CC-139D	3	C	3/4 x 1	Relief		15-4	C-6	SPT		1BVT 160.5-(R)		
RV-1CC-139E	3	C	3/4 x 1	Relief		15-4	D-6	SPT		1BVT 160.5-(R)		
RV-1CC-139F	3	C	3/4 x 1	Relief		15-4	E-6	SPT		1BVT 160.5-(R)		
RV-1CC-139G	3	C	3/4 x 1	Relief		15-4	E-6	SPT		1BVT 160.5-(R)		
RV-1CC-139H	3	C	3/4 x 1	Relief		15-4	E-6	SPT		1BVT 160.5-(R)		
RV-1CC-139I	3	C	3/4 x 1	Relief		15-4	F-6	SPT		1BVT 160.5-(R)		
RV-1CC-139J	3	C	3/4 x 1	Relief		15-4	F-6	SPT		1BVT 160.5-(R)		
RV-1CC-139K	3	C	3/4 x 1	Relief		15-4	F-6	SPT		1BVT 160.5-(R)		
RV-1CC-139L	3	C	3/4 x 1	Relief		15-4	G-6	SPT		1BVT 160.5-(R)		
RV-1CC-139M	3	C	3/4 x 1	Relief		15-4	D-6	SPT		1BVT 160.5-(R)		
RV-1CC-139N	3	C	3/4 x 1	Relief		15-4	D-6	SPT		1BVT 160.5-(R)		
RV-1CC-139P	3	C	3/4 x 1	Relief		15-4	C-6	SPT		1BVT 160.5-(R)		
RV-1CC-139R	3	C	3/4 x 1	Relief		15-4	C-6	SPT		1BVT 160.5-(R)		
RV-1CC-140A	3	C	3/4 x 1	Relief		15-4	B-3	SPT		1BVT 160.5-(R)		
RV-1CC-140B	3	C	3/4 x 1	Relief		15-4	B	SPT		1BVT 160.5-(R)		

JVPS-1 IST VALVE TESTING OUTLINE										SYSTEM NUMBER	TS
SYSTEM NAME: Reactor Plant Component Cooling Water										Comments	
Valve Mark Number	Valve Class	Valve Category	Valve Size (in.)	Valve Type	NSA	Drawing	OM No.	Coord	Test Requirement		
RV-1CC-140C	3	C	3/4 x 1	Relief		15-4	B-3		SPT	1BVT 1.60.5-(R)	
RV-1CC-140D	3	C	3/4 x 1	Relief		15-4	C-3		SPT	1BVT 1.60.5-(R)	
RV-1CC-140E	3	C	3/4 x 1	Relief		15-4	D-3		SPT	1BVT 1.60.5-(R)	
RV-1CC-140F	3	C	3/4 x 1	Relief		15-4	E-3		SPT	1BVT 1.60.5-(R)	
RV-1CC-140G	3	C	3/4 x 1	Relief		15-4	E-3		SPT	1BVT 1.60.5-(R)	
RV-1CC-140H	3	C	3/4 x 1	Relief		15-4	E-3		SPT	1BVT 1.60.5-(R)	
RV-1CC-140I	3	C	3/4 x 1	Relief		15-4	F-3		SPT	1BVT 1.60.5-(R)	
RV-1CC-140J	3	C	3/4 x 1	Relief		15-4	F-3		SPT	1BVT 1.60.5-(R)	
RV-1CC-140K	3	C	3/4 x 1	Relief		15-4	F-3		SPT	1BVT 1.60.5-(R)	
RV-1CC-140L	3	C	3/4 x 1	Relief		15-4	G-3		SPT	1BVT 1.60.5-(R)	
RV-1CC-140M	3	C	3/4 x 1	Relief		15-4	D-3		SPT	1BVT 1.60.5-(R)	
RV-1CC-140N	3	C	3/4 x 1	Relief		15-4	D-3		SPT	1BVT 1.60.5-(R)	
RV-1CC-140P	3	C	3/4 x 1	Relief		15-4	C-3		SPT	1BVT 1.60.5-(R)	
RV-1CC-140R	3	C	3/4 x 1	Relief		15-4	C-3		SPT	1BVT 1.60.5-(R)	
1CCR-247	2	A	18	Butterfly	LS	15-5	F-7		QS	10M-10.4-A-Stroke Only Open (CSD)	
									LT	RR1	1BVT 1.47.5-Leak Test (R)

BVPS-1 IST
VALVE TESTING OUTLINE

SYSTEM NAME: Reactor Plant Component Cooling Water

SYSTEM NUMBER: 15

Valve Mark Number	Valve Class	Valve Category	Valve Size (in.)	Valve Type	NSA	Drawing		Test Requirement	CSJ or Relief Requests	Comments
						OM No.	Coord.			
1CCR-248	2	A	18	Butterfly	LS	15-5	A-8	QS	CSJ18	10M-10.4 A-Stroke Only Open (CSD)
								LT	RR1	1BVT 1.47.5-Leak Test (R)
1CCR-251	2	A	18	Butterfly	LS	15-5	G-8	QS	CSJ18	10M-10.4 A-Stroke Only Open (CSD)
								LT	RR1	1BVT 1.47.5-Leak Test (R)
1CCR-252	2	A	18	Butterfly	LS	15-5	G-8	QS	CSJ18	10M-10.4 A-Stroke Only Open (CSD)
								LT	RR1	1BVT 1.47.5-Leak Test (R)
1CCR-289	3	C	2	Check		15-5	C-3	QS	RR28	1BVT 1.60.7-FS, RD by Leak Test (R)
1CCR-290	3	C	2	Check		15-5	D-3	QS	RR28	1BVT 1.60.7-FS, RD by Leak Test (R)
1CCR-291	3	C	2	Check		15-5	F-3	QS	RR28	1BVT 1.60.7-FS, RD by Leak Test (R)

INSERVICE TESTING (IST) PROGRAM FOR PUMPS AND VALVES

BVPS-1 IST VALVE TESTING OUTLINE										SYSTEM NUMBER: 20
SYSTEM NAME: Fuel Pool Cooling and Purification										Comments
Valve Mark Number	Valve Class	Valve Category	Valve Size (in.)	Valve Type	NSA	Drawing		Test Requirement	CSJ or Relief Requests	
						OM No.	Coord.			
1PC-9	2	A/P	6	Ball	LS	20-1	D-8	POS		Locked Valve Log
1PC-10		A/P	6	Ball	LS	20-1	D-7	POS	RR1	1BVT 1.47.5-Leak Test (R)
1PC-37	2	A/P	6	Ball	LS	20-1	D-8	POS		Locked Valve Log
1PC-36	2	A/P	6	Ball	LS	20-1	D-7	POS	RR1	1BVT 1.47.5-Leak Test (R)
								LT		Locked Valve Log
								LT	RR1	1BVT 1.47.5-Leak Test (R)

BVPS-1 IST
VALVE TESTING OUTLINE

SYSTEM NAME: Main Steam						SYSTEM NUMBER: 21				
Valve Mark Number	Valve Class.	Valve Category	Valve Size (in.)	Valve Type	NSA	Drawing		Test Requirement	CSJ or Relief Requests	Comments
						OM No.	Coord.			
1MS-15	2	B	3	Gate	LO	21-1	B-4	QS	CSJ21	1OST-24.4-Stroke Only Closed (Q) 1OST-24.9-Stroke Only Closed (CSD)
1MS-16	2	B	3	Gate	LO	21-1	D-4	QS	CSJ21	1OST-24.4-Stroke Only Closed (Q) 1OST-24.9-Stroke Only Closed (CSD)
1MS-17	2	B	3	Gate	LS	21-1	F-3	QS	CSJ21	1OST-24.4-Stroke Only Open (Q) 1OST-24.9-Stroke Only Open (CSD)
1MS-18	2	C	3	Check		21-1	G-4	QS		1OST-24.4-PS,FD (Q)
								QS	RR29	1OST-24.9-FS,FD (CSD)
								QS	RR29	1BVT-1.60.7-FS,RO by Leak Test (R)
1MS-19	2	C	3	Check		21-1	G-4	QS		1OST-24.4-PS,FD (Q)
								QS	RR29	1OST-24.9-FS,FD (CSD)
								QS	RR29	1BVT-1.60.7-FS,RO by Leak Test (R)
1MS-20	2	C	3	Check		21-1	G-4	QS		1OST-24.4-PS,FD (Q)
								QS	RR29	1OST-24.9-FS,FD (CSD)
								QS	RR29	1BVT-1.60.7-FS,RO by Leak Test (R)
1MS-80	2	C	3	Check		21-1	C-7	QS	RR30	Sample Disassembly and Inspection per 1CMP-75-CRANE CHECK-1M(R)
1MS-81	2	C	3	Check		21-1	C-7	QS	RR30	Sample Disassembly and Inspection per 1CMP-75-CRANE CHECK-1M(R)
1MS-82	2	C	3	Check		21-1	E-7	QS	RR30	Sample Disassembly and Inspection per 1CMP-75-CRANE CHECK-1M(R)
MOV-1MS-101A	2	B	2	Globe	S	21-1	C-8	QST		1OST-47.3A(3B)-Stroke & Time Closed (Q)(RPV)
NRV-1MS-101A	2	B/C	3/2	Check	O	21-1	B-8	QS	CSJ22	1OST-1.10-FS,RO (CSD)(RPV)

BVPS-1 IST
VALVE TESTING OUTLINE

SYSTEM NAME: Main Steam						SYSTEM NUMBER: 21				
Valve Mark Number	Valve Class	Valve Category	Valve Size (in.)	Valve Type	NSA	Drawing		Test Requirement	CSJ or Relief Requests	Comments
						OM No.	Cooru.			
PCV-1MS-101A		B	6	Globe	A	21-1	A-5	QST	CSJ23	1OST-1.10-Stroke & Time Open (C)(RPV)
SV-1MS-101A	2	C	6 x 10	Relief		21-1	B-4	SPT		1BVT 1.2.1 or 1BVT 1.2.2 (R)
TV-1MS-101A	2	B/C	32	Inverse Check	O	21-1	B-8	QST	CSJ24	1OST-21.4-Stroke & Time Closed (CSD)(RPV)
MOV-1MS-101B	2	B	2	Globe	S	21-1	E-8	QST		1OST-47.3A(3B)-Stroke & Time Closed (Q)(RPV)
NRV-1MS-101B	2	B/C	32	Check	O	21-1	D-8	QS	CSJ22	1OST-1.10-FS,RO (CSD)(RPV)
PCV-1MS-101B	2	B	6	Globe	A	21-1	C-5	QST	CSJ23	1OST-1.10-Stroke & Time Open (CSD)(RPV)
SV-1MS-101B	2	C	6 x 10	Relief		21-1	D-4	SPT		1BVT 1.21.1 or 1BVT 1.21.2 (R)
TV-1MS-101B	2	B/C	32	Inverse Check	O	21-1	D-8	QST	CSJ24	1OST-21.5-Stroke & Time Closed (CSD)(RPV)
MOV-1MS-101C	2	B	2	Globe	S	21-1	G-8	QST		1OST-47.3A(3B)-Stroke & Time Closed (Q)(RPV)
NRV-1MS-101C	2	B/C	32	Check	O	21-1	F-8	QS	CSJ22	1OST-1.10-FS,RO (CSD)(RPV)
PCV-1MS-101C	2	B	6	Globe	A	21-1	E-5	QST	CSJ23	1OST-1.10-Stroke & Time Open (CSD)(RPV)
SV-1MS-101C	2	C	6 x 10	Relief		21-1	E-4	SPT		1BVT 1.21.1 or 1EVT 1.21.2 (R)
TV-1MS-101C	2	B/C	32	Inverse Check	O	21-1	F-8	QST	CSJ24	1OST-21.6-Stroke & Time Closed (CSD)(RPV)
SV-1MS-102A	2	C	6 x 10	Relief		21-1	B-4	SPT		1BVT 1.21.1 or 1BVT 1.21.2 (R)
SV-1MS-102B	2	C	6 x 10	Relief		21-1	D-4	SPT		1BVT 1.21.1 or 1BVT 1.21.2 (R)
SV-1MS-102C	2	C	6 x 10	Relief		21-1	E-4	SPT		1BVT 1.21.1 or 1BVT 1.21.2 (R)
SV-1MS-103A	2	C	6 x 10	Relief		21-1	B-4	SPT		1BVT 1.21.1 or 1BVT 1.21.2 (R)

BVPS-1 IST
VALVE TESTING OUTLINE

SYSTEM NAME: Main Steam

SYSTEM NUMBER: 21

Valve Mark Number	Valve Class	Valve Category	Valve Size (in)	Valve Type	NSA	Drawing		Test Requirement	CSJ or Relief Requests	Comments
						OM No.	Coord			
SV-1MS-103B	2	C	6 x 10	Relief		21-1	D-4	SPT		1BVT 1.21.1 or 1BVT 1.21.2-(R)
SV-1MS-103C	2	C	6 x 10	Relief		21-1	E-4	SPT		1BVT 1.21.1 or 1BVT 1.21.2-(R)
SV-1MS-104A	2	C	6 x 10	Relief		21-1	D-3	SPT		1BVT 1.21.1 or 1BVT 1.21.2-(R)
SV-1MS-104B	2	C	6 x 10	Relief		21-1	D-3	SPT		1BVT 1.21.1 or 1BVT 1.21.2-(R)
SV-1MS-104C	2	C	6 x 10	Relief		21-1	E-3	SPT		1BVT 1.21.1 or 1BVT 1.21.2-(R)
SV-1MS-105A	2	C	6 x 10	Relief		21-1	B-3	SPT		1BVT 1.21.1 or 1BVT 1.21.2-(R)
SV-1MS-105B	2	C	6 x 10	Relief		21-1	D-3	SPT		1BVT 1.21.1 or 1BVT 1.21.2-(R)
SV-1MS-105C		C	6 x 10	Relief		21-1	E-3	SPT		1BVT 1.21.1 or 1BVT 1.21.2-(R)
TV-1MS-105A	3	B	3	Gate	S	21-1	G-4	QST		1OST-24.4-Stroke & Time Open (Q)(RPV)
TV-1MS-105B	3	B	3	Gate	S	21-1	G-5	QST		1OST-24.4-Stroke & Time Open (Q)(RPV)
MOV-1MS-105	3	B	3	Gate	O	21-1	G-4	QST		1OST-47.3A(3B)-Stroke & Time Open (Q)(RPV)
TV-1MS-111A	2	B	1 1/2	Gate	O	26-4	E-1	QST		1OST-47.3A(3B)-Stroke & Time Closed (C)(RPV)
TV-1MS-111B	2	B	1 1/2	Gate	C	26-4	C-1	QST		1OST-47.3A(3B)-Stroke & Time Closed (Q)(RPV)
TV-1MS-111C	2	B	1 1/2	Gate	O	26-4	A-1	QST		1OST-47.3A(3B)-Stroke & Time Closed (Q)(RPV)

SYSTEM NAME		BVPS-1 IST VALVE TESTING OUTLINE										SYSTEM NUMBER
Feedwater												24
Valve Mark Number	Valve Class	Valve Category	Valve Type	PISA	OM No	Coord	Test Requirement	CSJ or Relief Requests	Comments			
1FW-34	3	C	Check		24-2	E-7	QS	CSJ25	10ST-24.9-FS,FD (CSD)			
1FW-35	3	C	Check		24-2	E-2	QS	CSJ25	10ST-24.8-FS,FD (CSD)			
1FW-36	3	C	Check		24-2	E-4	QS	CSJ25	10ST-24.8-FS,FD,RD (CSD)			
1FW-37	3	B	Gate	LO	24-2	D-7	QS		10ST-24.4-Stroke Only Closed (Q)			
1FW-38	3	B	Gate	LO	24-2	D-2	QS		10ST-24.2-Stroke Only Closed (Q)			
1FW-39	3	B	Gate	S	24-2	D-4	QS		10ST-24.3-Stroke Only Open (Q)			
1FW-40	3	B	Gate	S	24-2	D-7	QS		10ST-24.4-Stroke Only Open (Q)			
1FW-41	3	B	Gate	S	24-2	D-2	QS		10ST-24.2-Stroke Only Open (Q)			
1FW-42	2	C	Check	LO	24-1	D-5	QS		10ST-24.3-Stroke Only Closed (Q)			
1FW-43	2	C	Check		24-1	B-7	QS	CSJ25	10ST-24.6-FS,FD (CSD)			
1FW-44	2	C	Check		24-1	E-7	QS	CSJ25	FS,RD by 10M-54 Log L3-16(Q) & 10ST-24.11(R)			
1FW-50	3	C	Check		24-2	E-7	QS	CSJ25	10ST-24.8-FS,FD (CSD)			
							QS		FS,RD by 10M-54 Log L3-16(Q) & 10ST-24.11(R)			
							QS		FS,RD by 10M-54 Log L3-16(Q) & 10ST-24.11(R)			
							QS		10ST-24.8-FS,FD (CSD)			
							QS		FS,RD by 10M-54 Log L3-16(Q) & 10ST-24.11(R)			
							QS		10ST-24.4-FS,FD (Q)			

BVPS-1 IST
VALVE TESTING OUTLINE

SYSTEM NAME Feedwater SYSTEM NUMBER 24

Valve Mark Number	Valve Class	Valve Category	Valve Size (in.)	Valve Type	NSA	Drawing		Test Requirement	CSJ or Relief Requests	Comments
						OM No.	Coord			
1FW-51	3	C	1	Check		24-2	E-2	QS		10ST-24.2-FS,FD (Q)
1FW-52	3	C	1	Check		24-2	E-5	QS		10ST-24.3-FS,FD (Q)
1FW-68	3	C	1	Check		24-2	E-8	QS		10ST-24.4-FS,FD (Q)
1FW-69	3	C	1	Check		24-2	E-2	QS		10ST-24.2-FS,FD (Q)
1FW-70	3	C	1	Check		24-2	E-5	QS		10ST-24.3-FS,FD (Q)
MOV-1FW-150A	3	B	20	Gate	O	24-3	C-3	QST	CSJ31	10ST-1.10-Stroke & Time Closed (CSD)(RPV)
MOV-1FW-150B	3	B	20	Gate	O	24-3	D-3	QST	CSJ31	10ST-1.10-Stroke & Time Closed (CSD)(RPV)
MOV-1FW-151A	2	B	3	Globe	O	24-2	C-3	QST		10ST-24.1-Stroke & Time Open (Q)(RPV)
MOV-1FW-151B	2	B	3	Globe	O	24-2	C-2	QST		10ST-24.1-Stroke & Time Open (Q)(RPV)
MOV-1FW-151C	2	B	3	Globe	O	24-2	B-3	QST		10ST-24.1-Stroke & Time Open (Q)(RPV)
MOV-1FW-151D	2	B	3	Globe	O	24-2	B-3	QST		10ST-24.1-Stroke & Time Open (Q)(RPV)
MOV-1FW-151E	2	B	3	Globe	O	24-2	A-3	QST		10ST-24.1-Stroke & Time Open (Q)(RPV)
MOV-1FW-151F	2	B	3	Globe	O	24-2	A-3	QST		10ST-24.1-Stroke & Time Open (Q)(RPV)
RV-1FW-155	2	C	3 x 4	Relief		24-2	F-7	SPT		1BVT 1.60.5 (R)
MOV-1FW-156A	2	B/C	16	Check	O	24-1	B-7	QST	CSJ26	10ST-1.10-Stroke & Time Closed (CSD)(RPV) 10ST-24.14A - Verify closure by Leak Test (R)
MOV-1FW-156B	2	B/C	16	Check	O	24-1	D-7	QST	CSJ26	10ST-1.10-Stroke & Time Closed (CSD)(RPV) 10ST-24.14B - Verify closure by Leak Test (R)
MOV-1FW-156C	2	B/C	16	Check	O	24-1	F-7	QST	CSJ26	10ST-1.10-Stroke & Time Closed (CSD)(RPV) 10ST-24.14C - Verify closure by Leak Test (R)

INSERVICE TESTING (IST) PROGRAM FOR PUMPS AND VALVES

BVPS-1 IST VALVE TESTING OUTLINE										SYSTEM NUMBER 24
SYSTEM NAME Feedwater										Comments
Valve Mark Number	Valve Class	Valve Category	Valve Size (in.)	Valve Type	NSA	Drawing		Test Requirement	CSJ or Relief Requests	
						OM No	Coord			
HCV-1FW-158A	2	B/P	3	Gate	O	24-1	B-7	POS	CSJ29	10ST-24-10 (M) 10ST-24-11 (RPV)
HCV-1FW-158B	2	B/P	3	Gate	O	24-1	D-7	POS	CSJ29	10ST-24-10 (M) 10ST-24-11 (RPV)
HCV-1FW-158C	2	B/P	3	Gate	O	24-1	G-7	POS	CSJ29	10ST-24-10 (M) 10ST-24-11 (RPV)
FCV-1FW-478	2	B	16	Globe	A	24-1	B-4	QST	CSJ29	10ST-1-10 Stroke & Time Closed (CSD)(RPV)
FCV-1FW-479	2	B	4	Globe	S	24-1	A-4	QST	CSJ29	10ST-47-14(3B) Stroke & Time Closed (Q)(RPV)
FCV-1FW-488	2	B	16	Globe	A	24-1	I-4	QST	CSJ29	10ST-1-10 Stroke & Time Closed (CSD)(RPV)
FCV-1FW-489	2	B	4	Globe	S	24-1	D-4	QST	CSJ29	10ST-47-3A(3B) Stroke & Time Closed (Q)(RPV)
FCV-1FW-496	2	B	16	Globe	A	24-1	F-4	QST	CSJ29	10ST-1-10 Stroke & Time Closed (CSD)(RPV)
FCV-1FW-499	2	B	4	Globe	S	24-1	F-4	QST	CSJ29	10ST-47-3A(3B) Stroke & Time Closed (Q)(RPV)
1FW-622	2	C	3	Check		24-2	C-4	QS	CSJ25	10ST-24-8-FS,FD,RO (CSD)
1FW-623	2	C	3	Check		24-2	C-4	QS	CSJ25	10ST-24-8-FS,FD,RO (CSD)
1FW-624	2	C	3	Check		24-2	B-4	QS	CSJ25	10ST-24-8-FS,FD,RO (CSD)
1FW-625	2	C	3	Check		24-2	B-4	QS	CSJ25	10ST-24-8-FS,FD,RO (CSD)
1FW-626	2	C	3	Check		24-2	A-4	QS	CSJ25	10ST-24-8-FS,FD,RO (CSD)
1FW-627	2	C	3	Check		24-2	A-4	QS	CSJ25	10ST-24-8-FS,FD,RO (CSD)

INSERVICE TESTING (IST) PROGRAM FOR PUMPS AND VALVES

BVPS-1 IST VALVE TESTING OUTLINE												SYSTEM NUMBER: 25
SYSTEM NAME: Steam Generator Blowdown												
Valve Mark Number	Valve Class	Valve Category	Valve Size (in)	Valve Type	MSA	Drawing		Test Requirement	CSJ or Relief Requests	Comments		
						OM No.	Coord.					
TV-1BD-100A	2	B	3	Globe	O	25-1	B-4	QST		*OST-47.3A(3B)-Stroke & Time Closed (Q)(RPV)		
TV-1BD-100B	2	B	3	Globe	O	25-1	D-4	QST		*OST-47.3A(3B)-Stroke & Time Closed (Q)(RPV)		
TV-1BD-100C	2	B	3	Globe	O	25-1	F-4	QST		†OST-47.3A(3B)-Stroke & Time Closed (Q)(RPV)		
TV-1BD-101A1	2	B	3	Gate	O	25-1	F-2	QST		†OST-47.3A(3B)-Stroke & Time Closed (Q)(RPV)		
TV-1BD-101A2	2	B	3	Gate	O	25-1	B-2	QST		†OST-47.3A(3B)-Stroke & Time Closed (Q)(RPV)		
TV-1BD-101B1	2	B	3	Gate	O	25-1	D-2	QST		†OST-47.3A(3B)-Stroke & Time Closed (Q)(RPV)		
TV-1BD-101B2	2	B	3	Gate	O	25-1	D-2	QST		†OST-47.3A(3B)-Stroke & Time Closed (Q)(RPV)		
TV-1BD-101C1	2	B	3	Gate	O	25-1	F-2	QST		†OST-47.3A(3B)-Stroke & Time Closed (Q)(RPV)		
TV-1BD-101C2	2	B	3	Gate	O	25-1	F-2	QST		†OST-47.3A(3B)-Stroke & Time Closed (Q)(RPV)		

INSERVICE TESTING (IST) PROGRAM FOR PUMPS AND VALVES

BVPS-1 IST VALVE TESTING OUTLINE										SYSTEM NUMBER: 27
SYSTEM NAME: Auxiliary Sys.										
Valve Mark Number	Valve Class	Valve Category	Valve Size (in.)	Valve Type	NSA	Drawing		Test Requirement	CSJ or Relief Requests	Comments
						OM No.	Coord.			
TS-1SV-100A	2	A	6	Globe	5	26-6	D-9	QST		*OST-47.3A(3B)-Stroke & Time Open/Closed (Q)(RPV)
1AS-276	2	A/C	6	Check		26-6	D-10	QS	RR1	*BVT 1.47.5-Leak Test (R)
HYV-1AS-101A	3	B	6	Gate	0	27-1	D-3	QST	RR1	*OST-47.3A(3B)-FS,FD (Q)
HYV-1AS-101B	3	B	6	Gate	0	27-1	D-2	QST		*BVT 1.47.5-Leak Test (R)
										*OST-47.3A(3R) - No Closed (Q)(RPV)
										*OST-47.3A(3B)-Stroke & Time Closed (Q)(RPV)

BVPS-1 IST VALVE TESTING OUTLINE										SYSTEM NUMBER	
SYSTEM NAME	Valve Mark Number	Valve Class	Valve Category	Valve Size (in.)	Valve Type	MSA	OM No	Coord	Test Requirement	CSJ or Relief Requests	Comments
River Water	1RW-57	3	C	20	Check		30-1	A-3	QS		10ST-30.2-FS,FD,RC (Q)
	1RW-58	3	C	20	Check		30-1	C-3	QS		10ST-30.3-FS,FD,RC (Q)
	1RW-59	3	C	20	Check		30-1	D-3	QS		10ST-30.6-FS,FD,RC (Q)
	1RW-95	3	C	3/4	Check		30-1	A-2	QS		10ST-30.2-FS,FD (Q)
	1RW-96	3	C	3/4	Check		30-1	B-2	QS		10ST-30.3-FS,FD (Q)
	1RW-97	3	C	3/4	Check		30-1	C-2	QS		10ST-30.6-FS,FD (Q)
	RV-1RW-101A	2	C	1/2 x 1	Relief		30-3	C-8	SPT		1BVT 1.60.5-(R)
	RV-1RW-101B	2	C	1/2 x 1	Relief		30-3	E-8	SPT		1BVT 1.60.5-(R)
	RV-1RW-101C	2	C	1/2 x 1	Relief		30-3	D-8	SPT		1BVT 1.60.5-(R)
	RV-1RW-101D	2	C	1/2 x 1	Relief		30-3	F-8	SPT		1BVT 1.60.5-(R)
	RV-1RW-102A	3	C	1/2 x 1	Relief		30-3	C-2	SPT		1BVT 1.60.5-(R)
	MOV-1RW-102A1	3	B	20	Butterfly	S	30-1	B-4	QST		10ST-30.2-Stroke & Time Oper (Q)(RPV)
	MOV-1RW-102A2	3	B	20	Butterfly	O	30-1	A-4	QST		10ST-30.2-Stroke & Time Oper (Q)(RPV)
	RV-1RW-102B	3	C	1/2 x 1	Relief		30-3	D-2			1BVT 1.60.5-(R)
	MOV-1RW-102B1	3	B	20	Butterfly	S	30-1	C-4	QST		10ST-30.3-Stroke & Time Oper (Q)(RPV)
	MOV-1RW-102B2	3	B	20	Butterfly	S	30-1	C-4	QST		10ST-30.3-Stroke & Time Oper (Q)(RPV)
	RV-1RW-102C	3	C	1/2 x 1	Relief		30-3	E-2	SPT		1BVT 1.60.5-(R)

**BVPS-1 IST
VALVE TESTING OUTLINE**

SYSTEM NAME River Water						SYSTEM NUMBER 30				
Valve Mark Number	Valve Class	Valve Category	Valve Size (in.)	Valve Type	NSA	Drawing		Test Requirement	CSJ or Relief Requests	Comments
						OM No.	Coord			
MOV-1RW-102C1	3	B	20	Butterfly	S	30-1	D-4	QST		1OST-30.6-Stroke & Time Open (Q)(RPV)
MOV-1RW-102C2	3	B	20	Butterfly	S	30-1	D-4	QST		1OST-30.6-Stroke & Time Open (Q)(RPV)
MOV-1RW-103A	3	B	24	Butterfly	S	30-3	B-2	QST		1OST-30.4-Stroke & Time Open (Q)(RPV)
MOV-1RW-103B	3	B	24	Butterfly	S	30-3	B-2	QST		1OST-30.4-Stroke & Time Open (Q)(RPV)
MOV-1RW-103C	3	B	24	Butterfly	S	30-3	G-2	QST		1OST-30.5-Stroke & Time Open (Q)(RPV)
MOV-1RW-103D	3	B	24	Butterfly	S	30-3	G-2	QST		1OST-30.5-Stroke & Time Open (Q)(RPV)
MOV-1RW-104	3	B	24	Butterfly	S	30-3	E-6	QST		1OST-30.4-Stroke & Time Open (Q)(RPV)
MOV-1RW-104A	2	B	14	Butterfly	O	30-3	C-6	QST		1OST-30.4-Stroke & Time Closed (Q)(RPV)
MOV-1RW-104B	2	B	14	Butterfly	O	30-3	F-6	QST		1OST-30.5-Stroke & Time Closed (Q)(RPV)
MOV-1RW-104C	2	B	14	Butterfly	O	30-3	D-6	QST		1OST-30.4-Stroke & Time Closed (Q)(RPV)
MOV-1RW-104D	2	B	14	Butterfly	O	30-3	G-6	QST		1OST-30.5-Stroke & Time Closed (Q)(RPV)
MOV-1RW-105A	2	B	14	Butterfly	O	30-3	C-9	QST		1OST-30.4-Stroke & Time Closed (Q)(RPV)
MOV-1RW-105B	2	B	14	Butterfly	O	30-3	E-9	QST		1OST-30.5-Stroke & Time Closed (Q)(RPV)
MOV-1RW-105C	2	B	14	Butterfly	O	30-3	D-9	QST		1OST-30.4-Stroke & Time Closed (Q)(RPV)
MOV-1RW-105D	2	B	14	Butterfly	O	30-3	F-9	QST		1OST-30.5-Stroke & Time Closed (Q)(RPV)
MOV-1RW-106A	3	B	24	Butterfly	O	30-3	C-1	QST		1OST-30.4-Stroke & Time Closed (Q)(RPV)
RV-1RW-106A	3	C	1/4 x 1	Relief		30-1	E-8	SPT		1BVT 1.60.5-(R)

Beaver Valley Power Station
 Unit 5
 INSERVICE TESTING (IST) PROGRAM FOR PUMPS AND VALVES

Issue 2
 Revision 8
 Page 101 of 180

BVPS-1 IST
VALVE TESTING OUTLINE

SYSTEM NAME		River Water						SYSTEM NUMBER 30		
Valve Mkt. Number	Valve Class	Valve Category	Valve Size (")	Valve Type	NSA	Drawing		Test Requirement	CSJ or Relief Requests	Comments
						OM No	Coord.			
MOV-1RW-106B	3	B	24	Butterfly	O	30-3	F-1	QST		1OST-30.5-Stroke & Time Closed (Q)(RPV)
RV-1RW-106B	3	C	1/2 x 1	Relief		30-1	E-7	SPT		1BVT 160.5 (R)
1RW-106	J	C	24	Check		30-1	A-9	QS		1OST-30.2(6)-FS,FD (Q)
								QS	RR31	1OST-30.3-FS,RD (R)
1RW-107	3	C	24	Check		30-1	D-9	QS		1OST-30.3(6)-FS,FD (Q)
								QS	RR31	1OST-30.8-FS,RD (R)
1RW-108	3	C	24	Check		30-3	E-4	QS		1OST-30.2(6)-FS,FD (Q)
1RW-109		L	24	Check		30-3	G-6	QS		1OST-30.3(6)-FS,FD (Q)
1RW-110	3	C	4	Check		30-1	F-8	QS		1OST-36.1-PS,FD (Q)
								QS	RR32	Sample Disassembly and Inspection per CMP 1/2-75-WAFER CHECK-1M (R)
1RW-111	3	C	4	Check		30-1	F-8	QS		1OST-36.1-PS,FD (Q)
								QS	RR32	Sample Disassembly and Inspection per CMP 1/2-75-WAFER CHECK-1M (R)
1RW-112	3	C	4	Check		30-1	G-8	QS		1OST-36.2-PS,FD (Q)
								QS	RR32	Sample Disassembly and Inspection per CMP 1/2-75-WAFER CHECK-1M (R)
1RW-113	3	C	4	Check		30-1	G-8	QS		1OST-36.2-PS,FD (Q)
								QS	RR32	Sample Disassembly and Inspection per CMP 1/2-75-WAFER CHECK-1M (R)
MOV-1RW-113A	3	B	4	Gate	S	30-1	F-10	QST		1OST-30.5-Stroke & Time Open (Q)(RPV)

Beaver Valley Power Station
 Unit 1
 INSERVICE TESTING (IST) PROGRAM FOR PUMPS AND VALVES
 Issue 2
 Revision 8
 Page 102 of 180

BEAVER VALLEY POWER STATION
VALVE AND PUMP SCHEDULE

SYSTEM NAME: River Water SYSTEM NUMBER: 30

Valve Mark Number	Valve Class	Valve Category	Valve Size (in)	Valve Type	NSA	Pumps		Test Requirement	CSJ or Relief Requests	Comments
						OM No	Coord.			
MOV-1RW-113B	3	B	4	Gate	S	30-1	F-10	QST		10ST-30.4-Stroke & Time Open (Q)(RPV)
MOV-1RW-113C	3	B	4	Gate	S	30-1	G-7	QST		10ST-30.5-Stroke & Time Open (Q)(RPV)
MOV-1RW-113D1	3	B	4	Gate	S	30-1	G-8	QST		10ST-30.5-Stroke & Time Open (Q)(RPV)
MOV-1RW-114A	3	B	24	Butterfly	O	30-3	B-1	QST		10ST-30.4-Stroke & Time Closed (Q)(RPV)
MOV-1RW-114B	3	B	24	Butterfly	O	30-3	F-1	QST		10ST-30.5-Stroke & Time Closed (Q)(RPV)
MOV-1RW-116	3	B	8	Butterfly	S	30-3	D-1	QST		10ST-30.4-Stroke & Time Open (Q)(RPV)
MOV-1RW-116A	3	B	24	Butterfly	S	30-1	B-10	QST		10ST-30.1A-Stroke & Time Open (Q)(RPV)
MOV-1RW-116B	3	B	24	Butterfly	S	30-1	D-10	QST		10ST-30.1B-Stroke & Time Open (Q)(RPV)
MOV-1RW-117	3	B	8	Butterfly	S	30-3	F-1	QST		10ST-30.5-Stroke & Time Open (Q)(RPV)
1RW-193	2	C	14	Check		30-3	C-7	QS		10ST-30.2(6)-FS,FD (Q)
1RW-194	2	C	14	Check		30-3	E-7	QS		10ST-30.2(6)-FS,FD (Q)
1RW-195	2	C	14	Check		30-3	F-7	QS		10ST-30.3(6)-FS,FD (Q)
1RW-196	2	C	14	Check		30-3	G-7	QS		10ST-30.3(6)-FS,FD (Q)
1RW-206	3	B	6	Butterfly	LS	24-1	F-10	QS		10ST-24.10-Stroke Only Open (M)
1RW-207	3	B	6	Butterfly	S	24-1	G-9	QS		10ST-24.10-Stroke Only Open (M)
1RW-208	3	B	6	Butterfly	S	24-1	F-8	QS		10ST-24.10-Stroke Only Open (M)
1RW-209	3	B	4	Butterfly	S	24-1	G-2	QS		10ST-24.10-Stroke Only Open (M)

Beaver Valley Power Station Unit 1
 INSERVICE TESTING (IST) PROGRAM FOR PUMPS AND VALVES
 Issue 2
 Revision 8
 Page 103 of 180

BVPS-1 IST
VALVE TESTING OUTLINE

SYSTEM NAME River Water

SYSTEM NUMBER 30

Valve Mark Number	Valve Class	Valve Category	Valve Size (in.)	Valve Type	NSA	Drawing		Test Requirement	CSJ or Relief Requests	Comments
						OM No.	Coord			
1RW-210	3	B	4	Butterfly	S	24-1	F-5	QS		1OST-24.10-Stroke Only Open (M)
1RW-466	3	C	3	Check		30-1	A-2	QS		1OST-30.2-FS,FD,RD (Q)
1RW-467	3	C	3	Check		30-1	C-2	QS		1OST-30.3-FS,FD,RD (Q)
1RW-468	3	C	3	Check		30-1	D-2	QS		1OST-30.6-FS,FD,RD (Q)
1RW-615	2	B	1	Ball	O	43-2	D-2	QS		1OST-47.3A(3B)-Stroke Only Closed (Q)
1RW-621	2	B	1	Ball	O	43-2	D-7	QS		1OST-47.3A(3B)-Stroke Only Closed (Q)
1RW-627	2	B	1	Ball	O	43-2	F-2	QS		1OST-47.3A(3B)-Stroke Only Closed (Q)
1RW-633	2	B	1	Ball	O	43-2	F-7	QS		1OST-47.3A(3B)-Stroke Only Closed (Q)
1RW-675	3	C	3/4	Check		30-1	A-2	QS	RR35	1OST-30.2-FS,FD (R)
1RW-676	3	C	3/4	Check		30-1	B-2	QS	RR35	1OST-30.3-FS,FD (R)
1RW-677	3	C	3/4	Check		30-1	D-2	QS	RR35	1OST-30.6-FS,FD (R)

INSERVICE TESTING (IST) PROGRAM FOR PUMPS AND VALVES

5/PS-1 IST VALVE TESTING OUTLINE												SYSTEM NUMBER: 33
SYSTEM NAME	Valve Mark Number	Valve Class	Valve Category	Valve Size (in.)	Valve Type	NSA	Drawing		Test Requirement	CSJ or Relief Requests	Comments	SYSTEM NUMBER: 33
							OM No.	Coord				
TV-1FP-105	2	A	4	Gate	S	33-1B	C-4	QST	RR1	1CST-47.3A(3B)-Stroke & Time Closed (Q)(RPV)		
TV-1FP-106	2	A	4	Gate	S	33-1B	C-4	QST	RR1	1BVT 1.47.5-Leak Test (R)		
TV-1FP-107	2	A	4	Globe	S	33-1B	C-5	QST	RR1	1OST-47.3A(3B)-Stroke & Time Closed (Q)(RPV)		
1FP-800	2	A/C	4	Check		33-1B	D-4	QS	RR1	1BVT 1.47.5-Leak Test (R)		
1FP-804	2	A/C	4	Check		33-1B	D-4	QS	CSJ27	1OST-1.10-FS,FD,RD by Mechanical Exerciser (CSD)		
1FP-827	2	A/C	4	Check		33-1B	D-5	QS	RR1	1BVT 1.47.5-Leak Test (R)		
								LT	RR1	1OST-1.10-FS,FD,RD by Mechanical Exerciser (CSD)		
								LT	RR1	1BVT 1.47.5-Leak Test (R)		

BVPS 1 IST VALVE TESTING OUTLINE											SYSTEM NUMBER 34
SYSTEM NAME: Compressed Air (Station Air)											Comments
Valve Mark Number	Valve Class	Valve Category	Valve Size (in.)	Valve Type	NSA	Drawings		Test Requirement	CSJ or Relief Requests		
						OM No	Coord				
1SA-14	2	A/P	2	Gate	LS	34-1	B-10	LT	RR1	1BVT 1.47.5-Leak Test (R)	
1SA-15	2	A/C/P	2	Check		34-1	B-10	LT	RR1	1BVT 1.47.5-Leak Test (R)	

BVPS-1 IST
VALVE TESTING OUTLINE

SYSTEM NAME: Compressed Air (Instrument Air) SYSTEM NUMBER 34

Valve Mark Number	Valve Class	Valve Category	Valve Size (in)	Valve Type	NSA	Drawing		Test Requirement	CSJ or Relief Requests	Comments
						OM No.	Coord.			
11A-90	2	A/P	2	Gate	LS	34-2	E-2	LT	RR1	1BVT 1.47.5-Leak Test (R)
11A-91	2	A/C/P	1	Check		34-2	E-3	LT	RR1	1BVT 1.47.5-Leak Test (R)

INSERVICE TESTING (IST) PROGRAM FOR PUMPS AND VALVES

BVPS-1 IST VALVE TESTING OUTLINE												SYSTEM NUMBER
SYSTEM NAME 4KV Station Service (Diesel Air Start)												36
Valve Mark Number	Valve Class	Valve Category	Valve Size (in.)	Valve Type	NSA	Drawing		Test Requirement	CSJ or Relief Requests	Comments		
						OM No	Coord.					
1DA-100	3	C	3/4	Check		36-1	A-2	QS		1OST-36.1-FS.RD (Q)		
1DA-101	3	C	3/4	Check		36-1	A-4	QS		1OST-36.1-FS.RD (Q)		
1DA-104	3	B/P	1 1/2	Ball	LS	36-1	B-3	POS		Locked or sealed valve log		
1DA-130	3	C	3/4	Check		36-1	A-7	QS		1OST-36.2-FS.RD (Q)		
1DA-131	3	C	3/4	Check		36-1	A-9	QS		1OST-36.2-FS.RD (Q)		
1DA-134	3	B/P	1 1/2	Ball	LS	36-1	B-8	POS		Locked or sealed valve log		
SOV-1EE-101	3	B	3/8	Solenoid	S	-1	F-2	QST	RR36	1OST-36.1-Stroke & Time Open (Bi-Monthly)		
SOV-1EE-102	3	B	3/8	Solenoid	S	36-1	F-4	QST	RR36	1OST-36.1-Stroke & Time Open (Bi-Monthly)		
SOV-1EE-103	3	B	3/8	Solenoid	S	36-1	F-7	QST	RR36	1OST-36.2-Stroke & Time Open (Bi-Monthly)		
SOV-1EE-104	3	B	3/8	Solenoid	S	36-1	F-8	QST	RR36	1OST-36.2-Stroke & Time Open (Bi-Monthly)		
RV-1EE-201A	3	C	1/2	Relief		36-1	C-1	SPT		1BVT 1.60.5-(R)		
RV-1EE-201B	3	C	1/2	Relief		36-1	D-1	SPT		1BVT 1.60.5-(R)		
RV-1EE-201C	3	C	1/2	Relief		36-1	D-1	SPT		1BVT 1.60.5-(R)		
RV-1EE-202A	3	C	1/2	Relief		36-1	C-5	SPT		1BVT 1.60.5-(R)		
RV-1EE-202B	3	C	1/2	Relief		36-1	D-5	SPT		1BVT 1.60.5-(R)		
RV-1EE-202C	3	C	1/2	Relief		36-1	D-5	SPT		1BVT 1.60.5-(R)		
RV-1EE-203A	3	C	1/2	Relief		36-1	C-6	SPT		1BVT 1.60.5-(R)		

BVPS-1 IST VALVE TESTING OUTLINE										SYSTEM NUMBER 36
SYSTEM NAME 4KV Station Service (Diesel Air Start)										
Valve Mark Number	Valve Class	Valve Category	Valve Size (in.)	Valve Type	NSA	Drawing		Test Requirement	CSJ or Relief Requests	Comments
						OM No.	Coord.			
RV-1EE-203B	3	C	1/2	Relief		36-1	D-6	SPT	1BVT 1.60.5-(R)	
RV-1EE-203C	3	C	1/2	Relief		36-1	D-6	SPT	1BVT 1.60.5-(R)	
RV-1EE-204A	3	C	1/2	Relief		36-1	C-10	SPT	1BVT 1.60.5-(R)	
RV-1EE-204B	3	C	1/2	Relief		36-1	D-10	SPT	1BVT 1.60.5-(R)	
RV-1EE-204C	3	C	1/2	Relief		36-1	D-10	SPT	1BVT 1.60.5-(R)	

BVPS-1 IST VALVE TESTING OUTLINE												SYSTEM NUMBER
SYSTEM NAME: 4KV Station Service (Diesel Fuel Oil)												36
Valve Mark Number	Valve Class	Valve Category	Valve Size (in.)	Valve Type	NSA	Drawing		Test Requirement	CSJ or Relief Requests	Comments		
						OM No	Coord					
1FO-7	3	C	3/4	Check		36-2	B-5	QS		1OST-36.1-FS,FD,RD (M)		
1FO-8	3	C	3/4	Check		36-2	A-5	QS		1OST-36.1-FS,FD,RD (M)		
1FO-9	3	C	3/4	Check		36-2	E-5	QS		1OST-36.2-FS,FD,RD (M)		
1FO-10	3	C	3/4	Check		36-2	E-5	QS		1OST-36.2-FS,FD,RD (M)		
1FO-15	3	B	3/4	Gate	S	36-2	B-5	QS		1OST-47.3A-Stroke Only Open (Q)		
1FO-16	3	B	3/4	Gate	S	36-2	D-5	QS		1OST-47.3A-Stroke Only Open (Q)		
1FO-35	3	C	2	Check		36-2	B-3	QS		1OST-36.1-FS,FD (M)		
1FO-36	3	C	2	Check		36-2	E-3	QS		1OST-36.2-FS,FD (M)		
RV-1EE-101A	3	C	3/4 x 1	Relief		36-2	B-4	SPT		1BVT 160.5-(R)		
RV-1EE-101B	3	C	3/4 x 1	Relief		36-2	A-4	SPT		1BVT 160.5-(R)		
RV-1EE-101C	3	C	3/4 x 1	Relief		36-2	E-4	SPT		1BVT 160.5-(R)		
RV-1EE-101D	3	C	3/4 x 1	Relief		36-2	E-4	SPT		1BVT 160.5-(R)		

BVPS-1 IST
VALVE TESTING OUTLINE

SYSTEM NAME: Control Area Ventilation

SYST. M NUMBER 44A

Valve Mark Number	Valve Class	Valve Category	Valve Size (in.)	Valve Type	NSA	Drawing		Test Requirement	CSJ or Relief Requests	Comments
						OM No	Coord			
RV-1VS-101A	3	C	½ x 1	Relief		44A-1	F-2	SPT		1BVT 1.60.5-(R)
TV-1VS-101A	3	B	1	Gate	S	44A-1	G-3	QST	RR37	3BVT 1.44.1-Stroke Only Open (Every 18 Months)
RV-1VS-101B	3	C	½ x 1	Relief		44A-1	F-2	SPT		1BVT 1.60.5-(R)
TV-1VS-101B	3	B	1	Gate	S	44A-1	F-3	QST	RR37	3BVT 1.44.1-Stroke Only Open (Every 18 Months)
RV-1VS-101C	3	C	½ x 1	Relief		44A-1	E-2	SPT		1BVT 1.60.5-(R)
TV-1VS-101C	3	B	1	Gate	S	44A-1	E-3	QST	RR37	3BVT 1.44.1-Stroke Only Open (Every 18 Months)
RV-1VS-101D	3	C	½ x 1	Relief		44A-1	D-2	SPT		1BVT 1.60.5-(R)
TV-1VS-101D	3	B	1	Gate	S	44A-1	D-3	QST	RR37	3BVT 1.44.1-Stroke Only Open (Every 18 Months)
RV-1VS-101E	3	C	½ x 1	Relief		44A-1	C-2	SPT		1BVT 1.60.5-(R)
TV-1VS-101E	3	B	1	Gate	S	44A-1	C-3	QST	RR37	3BVT 1.44.1-Stroke Only Open (Every 18 Months)

Beaver Valley Power Station
 Unit 1
 INSERVICE TESTING (IST) PROGRAM FOR PUMPS AND VALVES

Issue 2
 Revision 8
 Page 111 of 180

BVPS-1 IST
VALVE TESTING OUTLINE

SYSTEM NAME Containment Area Ventilation						SYSTEM NUMBER 44C				
Valve Mark Number	Valve Class	Valve Category	Valve Size (in)	Valve Type	NSA	Drawing		Test Requirement	CSJ or Relief Requests	Comments
						OM No.	Coord			
1VS-D-5-3A	2	A	42	MOV Damper	LS	44C-15	None	QST	CSJ28	1OST-1.10-Stroke & Time Closed (CSD)(RPV)
								LT	RR1,RR38	1BVT 1.47.5-Leak Test (R)
1VS-D-5-3B	2	A	42	MOV Damper	LS	44C-15	None	QST	CSJ28	1OST-1.10-Stroke & Time Closed (CSD)(RPV)
								LT	RR1,RR38	1BVT 1.47.5-Leak Test (R)
1VS-D-5-5A	2	A	42	MOV Damper	LS	44C-15	None	QST	CSJ28	1OST-1.10-Stroke & Time Closed (CSD)(RPV)
								LT	RR1,RR38	1BVT 1.47.5-Leak Test (R)
1VS-D-5-5B	2	A	42	MOV Damper	LS	44C-15	None	QST	CSJ28	1OST-1.10-Stroke & Time Closed (CSD)(RPV)
								LT	RR1,RR39	1BVT 1.47.5-Leak Test (R)
1VS-D-5-6	2	A/P	8	Manual Damper	S	44C-15	None	LT	RR1,RR39	1BVT 1.47.5-Leak Test (R)

**BVPS-1 IST
VALVE TESTING OUTLINE**

SYSTEM NAME: Post DBA Hydrogen Control

SYSTEM NUMBER: 46

Valve Mark Number	Valve Class	Valve Category	Valve Size (in.)	Valve Type	NSA	Drawing		Test Requirement	CSJ or Relief Requests	Comments
						OM No	Coord			
1HY-101	2	A	2	Ball	LS	46-1	A-3	QS		1OST-47.3A(3B)-Stroke Only Open (Q)
								LT	RR1,RR40	1BVT 1.47.5-Leak Test (R)
1HY-102	2	A	2	Ball	LS	46-1	E-3	QS		1OST-47.3A(3B)-Stroke Only Open (Q)
								LT	RR1,RR41	1BVT 1.47.5-Leak Test (R)
MOV-1HY-102A	2	B	2	Ball	S	46-1	B-5	QST		1OST-47.3A(3B)-Stroke & Time Open (Q)(RPV)
SOV-1HY-102A1	2	A	3/8	Globe	S	46-2	A-3	QST		1OST-47.3A(3B)-Stroke & Time Closed (Q)
								LT	RR1	1BVT 1.47.5-Leak Test (R)(RPV)
SOV-1HY-102A2	2	A	3/8	Globe	S	46-2	B-4	QST		1OST-47.3A(3B)-Stroke & Time Closed (Q)
								LT	RR1	1BVT 1.47.5-Leak Test (R)(RPV)
MOV-1HY-102B	2	B	2	Ball	S	46-1	E-5	QST		1OST-47.3A(3B)-Stroke & Time Open (Q)(RPV)
SOV-1HY-102B1	2	A	3/8	Globe	S	46-2	E-3	QST		1OST-47.3A(3B)-Stroke & Time Closed (Q)
								LT	RR1	1BVT 1.47.5-Leak Test (R)(RPV)
SOV-1HY-102B2	2	A	3/8	Globe	S	46-2	E-4	QST		1OST-47.3A(3B)-Stroke & Time Closed (Q)
								LT	RR1	1BVT 1.47.5-Leak Test (R)(RPV)
1HY-103	2	A	2	Ball	LS	46-1	A-3	QS		1OST-47.3A(3B)-Stroke Only Open (Q)
								LT	RR1,RR40	1BVT 1.47.5-Leak Test (R)

Beaver Valley Power Station
Unit 1
INSERVICE TESTING (IST) PROGRAM FOR PUMPS AND VALVES

Issue 2
Revision 8
Page 113 of 180

BVPS-1 IST
VALVE TESTING OUTLINE

SYSTEM NAME: Post DBA Hydrogen Control

SYSTEM NUMBER 46

Valve Mark Number	Valve Class	Valve Category	Valve Size (in.)	Valve Type	NSA	Drawing		Test Requirement	CSJ or Relief Requests	Comments
						OM No.	Coord.			
SOV-1HY-103A1	2	A	3/8	Globe	S	46-2	B-3	QST		1OST-47.3A(3B)-Stroke & Time Closed (Q)
								LT	RR1	1BVT 1.47.5-Leak Test (R)(RPV)
SOV-1HY-103A2	2	A	3/8	Gate	S	46-2	B-4	QST		1OST-47.3A(3B)-Stroke & Time Closed
								LT	RR1	1BVT 1.47.5-Leak Test (R)(RPV)
SOV-1HY-103B1	2	A	3/8	Gate	S	46-2	F-3	QST		1OST-47.3A(3B)-Stroke & Time Closed (Q)
								LT	RR1	1BVT 1.47.5-Leak Test (R)(RPV)
SOV-1HY-103B2	2	A	3/8	Gate	S	46-2	F-4	QST		1OST-47.3A(3B)-Stroke & Time Closed (Q)
								LT	RR1	1BVT 1.47.5-Leak Test (R)(RPV)
1HY-104	2	A	2	Ball	LS	46-1	E-3	QS		1OST-47.3A(3B)-Stroke Only Open (Q)
								LT	RR1,RR41	1BVT 1.47.5-Leak Test (R)
SOV-1HY-104A1	2	A	3/8	Gate	S	46-2	C-3	QST		1OST-47.3A(3B)-Stroke & Time Closed (Q)
								LT	RR1	1BVT 1.47.5-Leak Test (R)(RPV)
SOV-1HY-104A2	2	A	3/8	Gate	S	46-2	C-4	QST		1OST-47.3A(3B)-Stroke & Time Closed (Q)
								LT	RR1	1BVT 1.47.5-Leak Test (R)(RPV)
SOV-1HY-104B1	2	A	3/8	Gate	S	46-2	G-3	QST		1OST-47.3A(3B)-Stroke & Time Closed (Q)
								LT	RR1	1BVT 1.47.5-Leak Test (R)(RPV)

BVPS-1 IST
VALVE TESTING OUTLINE

SYSTEM NAME: Post DBA Hydrogen Control						SYSTEM NUMBER: 46				
Valve Mark Number	Valve Class	Valve Category	Valve Size (in.)	Valve Type	NSA	Drawing		Test Requirement	CSJ or Relief Requests	Comments
						OM No.	Coord.			
SOV-1HY-104B2	2	A	3/8	Gate	S	46-2	F-4	QST		1OST-47.3A(3B)-Stroke & Time Closed (Q)
								LT	RR1	1BVT 1.47.5-Leak Test (R)(RPV)
1HY-110	2	A	2	Ball	LS	46-1	C-2	QS		1OST-47.3A(3B)-Stroke Only Open (Q)
								LT	RR1	1BVT 1.47.5-Leak Test (R)
1HY-111	2	A	2	Ball	LS	46-1	G-2	QS		1OST-47.3A(3B)-Stroke Only Open (Q)
								LT	RR1	1BVT 1.47.5-Leak Test (R)
1HY-196	2	A	2	Ball	LS	46-1	C-3	QS		1OST-47.3A(3B)-Stroke Only Open (Q)
								LT	RR1	1BVT 1.47.5-Leak Test (R)
1HY-197	2	A	2	Ball	LS	46-1	G-3	QS		1OST-47.3A(3B)-Stroke Only Open (Q)
								LT	RR1	1BVT 1.47.5-Leak Test (R)

Beaver Valley Power Station Unit 1
 INSERVICE TESTING (IST) PROGRAM FOR PUMPS AND VALVES

Issue 2
 Revision 8
 Page 115 of 180

BVPS-1 IST VALVE TESTING OUTLINE											SYSTEM NUMBER
SYSTEM NAME: Containment											47
Valve Mark Number	Valve Class	Valve Category	Valve Size (in)	Valve Type	NSA	Drawing		Test Requirement	CSJ or Relief Requests	Comments	
						OM No.	Coord				
1VS-167	2	A/P	1 1/2	Ball	S	47-5	None	LT	RR1	1BVT 1.47.5-Leak Test (R)	
1VS-168	2	A/P	1 1/2	Ball	S	47-5	None	LT	RR1	1BVT 1.47.5-Leak Test (R)	
1VS-169	2	A/P	1 1/2	Ball	S	47-5	None	LT	RR1	1BVT 1.47.5-Leak Test (R)	
1VS-170	2	A/P	1 1/2	Ball	S	47-5	None	LT	RR1	1BVT 1.47.5-Leak Test (R)	
1VS-176	3	B/P	1 1/2	Gate	S	47-5	None	NA		NA	
1VS-177	3	B/P	1 1/2	Gate	S	47-5	None	NA		NA	
1VS-178	3	B/P	1 1/2	Gate	S	47-5	None	NA		NA	
1VS-179	3	B/P	1 1/2	Gate	S	47-5	None	NA		NA	
1VS-183	2	A/P	2	Ball	S	47-7	None	LT	RR42	1BVT 1.47.10-Type B Leak Test (SA)	
1VS-184	2	A/P	2	Ball	S	47-7	None	LT	RR42	1BVT 1.47.10-Type B Leak Test (SA)	

SECTION VI: VALVE TESTING COLD SHUTDOWN JUSTIFICATIONS

COLD SHUTDOWN JUSTIFICATION 1 **Valve No.:**

SOV-1RC-102A
SOV-1RC-102B
SOV-1RC-103A
SOV-1RC-103B
SOV-1RC-104
SOV-1RC-105

Category B **Class** 1 **Function:**

Reactor coolant system high points vents.

Test Requirement:

Quarterly full stroke and time.

Basis for CSJ:

These valves are closed during normal operation and are designed to vent the RCS in an emergency to assure that core cooling during natural circulation will not be inhibited by a buildup of noncondensable gases. Periodic stroking of these valves at power could degrade this system by repeatedly challenging the downstream valves due to a phenomenon known as "burping". This phenomenon has been previously described in ASME report "Spurious Opening of Hydraulic-Assisted, Pilot-Operated Valves - An Investigation of the Phenomenon". The phenomenon involves a rapid pressure surge buildup at the valve inlet caused by opening the upstream valve in a series double isolation arrangement or closing a valve in a parallel redundant flow path isolation arrangement. The pressure surge is sufficient enough to lift the valve plug until a corresponding pressure increase in a control chamber above the pilot and disc can create enough downward differential pressure to close the valve.

Alternate Test:

Full-stroke exercise and time open at cold shutdowns per 1OST-1.10. This frequency is consistent with T.S. 3.4.12 which was written to comply with the requirements of NUREG 0737, "Clarification of TMI Action Plant Requirements".

COLD SHUTDOWN JUSTIFICATION 2

Valve No.:

PCV-1RC-455C

PCV-1RC-455D

PCV-1RC-456

Category 1Class B

Function:

PORVs

Test Requirement:

Quarterly full stroke and time.

Basis (o. CSJ):

The PORVs are not needed for overpressure protection during power operation since the pressurizer code safety valves fulfill this function. In the event that a PORV was to fail or stick open while being cycled at power, the potential loss of RCS inventory through this relief path could lead to a forced plant shutdown. Therefore, stroking these valves at power is not considered practical.

Additionally, when the plant is shutdown only two of the three valves ([PCV-1RC-455C and D]) are actually utilized to provide protection against exceeding 10CFR50, Appendix G limits during periods of RCS water solid operation. The third PORV ([PCV-1RC-456]) does not have a low pressure set point to the logic controlling it.

Alternate Test:

Full-stroke exercise and timing open will be performed each cold shutdown per 1OST-6.8 for the two valves used for overpressure protection. The third valve will be full-stroke exercised and timed open at the normal cold shutdown frequency per 1OST-1.10.

COLD SHUTDOWN JUSTIFICATION 3**Valve No.:**

1CH-75

1CH-76

Category C**Class** 3**Function:**

Discharge check valves for the boric acid transfer pumps.

Test Requirement:

Quarterly full stroke.

Basis for CSJ:

These valves can only be full-stroke exercised by initiating flow through the emergency boration path and verifying it using the installed flow instrumentation in this flowpath. Testing in this manner would cause an undesired reactivity transient through the direct injection of 7,000 ppm borated water to the suction of the charging pumps. The resultant over boration of the RCS would cause a temperature transient as Tavg dropped to compensate and could cause a plant shutdown.

Alternate Test:

Valves to be full-stroke exercised open during cold shutdown per 1OST-1.10. Valves are part-stroke exercised open quarterly when the boric acid transfer pumps are tested through their recirculation flow paths per 1OST-7.1 & 7.2.

COLD SHUTDOWN JUSTIFICATION 4**Valve No.:**

MOV-1CH-115C

MOV-1CH-115E

Category B**Class** 2**Function:**

Volume Control Tank outlet isolation valves.

Test Requirement:

Quarterly full stroke and time.

Basis for CSJ:

These valves are normally open and cannot be exercised during power operation without isolating the Volume Control Tank from the charging pumps. This would result in a loss of normal Reactor Coolant System makeup and reactor coolant pump seal injection water causing possible pump and system degradation.

Alternate Test:

Full-stroke exercise and time closed at cold shutdown per 1OST-1.10.

COLD SHUTDOWN JUSTIFICATION 5**Valve No.:**

1CH-141

Category C**Class** 2**Function:**

Emergency boration line check valve.

Test Requirement:

Quarterly full stroke

Basis for CSJ:

This valve is closed during normal operation and can only be exercised by initiating flow through the emergency boration path. Testing in this manner would cause an undesired reactivity transient through the direct injection of 7,000 ppm borated water to the suction of the charging pumps. The resultant over-boration of the RCS would cause a temperature transient as Tavg dropped to compensate and could cause a plant shutdown.

Alternate Test:

Valve to be full-stroke exercised open during cold shutdown per 1OST-1.10.

COLD SHUTDOWN JUSTIFICATION 6**Valve No.:**MOV-1CH-289
TV-1CH-204**Category** A**Class** 2**Function:**

Reactor coolant makeup and letdown outside containment isolation valves.

Test Requirement:

Quarterly full stroke and time.

Basis for CSJ:

Quarterly stroking at power of either valve to its closed position would cause an undesirable transient in the reactor coolant makeup and letdown systems. A failure of either valve in the closed position could lead to a loss of pressurizer level control and require a plant shutdown.

Alternate Test:

Full-stroke exercise and time closed at cold shutdown per 1OST-1.10.

COLD SHUTDOWN JUSTIFICATION 7**Valve No.:**MOV-1CH-310
LCV-1CH-460A
LCV-1CH-460B**Category** B**Class** 1**Function:**

Reactor coolant makeup and letdown isolation valves.

Test Requirement:

Quarterly full stroke and time.

Basis for CSJ:

Quarterly stroking at power to their closed position would cause an undesirable transient in the reactor coolant makeup and letdown systems. A failure of one or more valves in the closed position could lead to a loss of pressurizer level control and require a plant shutdown.

Alternate Test:

Full-stroke exercise and time closed at cold shutdown per 1OST-1.10.

COLD SHUTDOWN JUSTIFICATION 8

Valve No.:

MOV-1CH-373

Category BClass 2

Function:

HHSI pump to VCT miniflow isolation valve.

Test Requirement:

Quarterly full stroke and time.

Basis for CSJ:

Quarterly full stroke testing at power is considered impractical since it would cause an undesirable flow perturbation in the reactor coolant makeup system. Also the failure of this valve in the closed position could result in damage to all three charging pumps.

Alternate Test:

Full-stroke exercise and time closed at cold shutdown per 1OST-1.10.

COLD SHUTDOWN JUSTIFICATION 9

Valve No.:

1CH-84

1CH-136

Category CClass 3

Function:

Alternate Emergency Boration Flow Path Check Valves.

Test Requirement:

Quarterly full stroke.

Basis for CSJ:

These valves must open to fulfill their safety function to provide an alternate emergency boration flow path from the boric acid tanks to the reactor coolant system. They can only be exercised by initiating flow through the emergency boration path. Testing in this manner would cause an undesired reactivity transient through the direct injection of 7,000 ppm borated water to the suction of the charging pumps. The resultant over-boration of the RCS would cause a temperature transient as Tavg dropped to compensate and could lead to a forced plant shutdown.

Alternate Test:

Full-stroke exercised open during cold shutdowns per 1OST-1.10.

COLD SHUTDOWN JUSTIFICATION 10**Valve No.:**

1RH-3

1RH-4

Category C**Class** 2**Function:**

Residual Heat Removal Pumps Discharge Check Valves.

Test Requirement:

Quarterly full stroke.

Basis for CSJ:

These valves can only be full stroke exercised when the RHR Pumps are running. The RHR Pumps are only run during cold shutdowns. Quarterly part stroking is also not possible due to the inaccessibility of the valves and pumps which are located inside the subatmospheric containment building.

Alternate Test:

Forward and reverse flow exercised per 10ST-10.1 during cold shutdown.

COLD SHUTDOWN JUSTIFICATION 11**Valve No.:**

MOV-1RH-700

MOV-1RH-701

MOV-1RH-720A

MOV-1RH-720B

Category A**Class** 1**Function:**

Residual Heat Removal System Inlet and Outlet isolation valves.

Test Requirement:

Quarterly full stroke and time.

Basis for CSJ:

Cycling these valves could subject the RHR system to pressure greater than design. These valves are normally closed and de-energized during power operation and are required to be closed during an accident.

Alternate Test:

These valves are full-stroke exercised and timed open each plant cooldown or heatup from cold shutdown per 10ST-10.4.

COLD SHUTDOWN JUSTIFICATION 12**Valve No.:**

MOV-1SI-836
MOV-1SI-869A

Category A**Class** 2**Function:**

Outside containment isolation valves from the fill and charging headers to the RCS hot and cold legs.

Test Requirement:

Quarterly full stroke and time.

Basis for CSJ:

These valves are shut at power and are required to remain shut at the onset of an accident. Cycling them at power would thermal shock the RCS cold leg nozzles and compromise system integrity.

Alternate Test:

Full-stroke exercise and time closed at cold shutdown per 1OST-1.10.

COLD SHUTDOWN JUSTIFICATION 13**Valve No.:**

MOV-1SI-860A
MOV-1SI-860B

Category A**Class** 2**Function:**

Low Head Safety Injection pump containment sump suction valves.

Test Requirement:

Quarterly full stroke and time.

Basis for CSJ:

These valves are containment isolation valves exposed to containment atmosphere. Failure of these valves in the open position during power operation would compromise containment integrity.

Alternate Test:

Full-stroke exercise and time open at cold shutdown per 1OST-1.10.

COLD SHUTDOWN JUSTIFICATION 14

Valve No.:

MOV-1SI-869B

Category AClass 2

Function:

Charging header BIT bypass to RCS hot legs outside containment isolation.

Test Requirement:

Quarterly full stroke and time.

Basis for CSJ:

This valve is shut during power operation and is not required to change position to fulfill its initial safety function. The valve is only opened during the simultaneous cold and hot leg recirculation phase. In addition, stroking this valve would thermal stress the hot leg injection nozzle.

Alternate Test:

Full-stroke exercise and time closed at cold shutdown per 1OST-1.10.

COLD SHUTDOWN JUSTIFICATION 15

Valve No.:

MOV-1SI-890C

Category AClass 2

Function:

Low Head Safety Injection outside containment isolation to RCS cold legs.

Test Requirement:

Quarterly full stroke and time.

Basis for CSJ:

This valve is open during normal operation and is required to remain open to fulfill its safety function at the onset of an accident. Failure of this valve to reopen after exercising would render LHSI cold leg injection from both trains inoperable.

Alternate Test:

Full-stroke exercise and time open at cold shutdown per 1OST-1.10.

COLD SHUTDOWN JUSTIFICATION 16**Valve No.:**

1QS-3
1QS-4
1RS-100
1RS-101

Category A/C**Class** 2**Function:**

Inside containment isolation discharge check valves for the quench spray and recirculation spray pumps.

Test Requirement:

Quarterly full stroke.

Basis for CSJ:

These valves are all physically located in the subatmospheric containment building. Also the valves cannot be full-stroked open with flow since any test requiring injecting water through the spray nozzles would cause damage to electrical equipment and result in a significant contamination cleanup effort in the containment building.

Alternate Test:

Full-stroke exercised open by mechanical exerciser utilizing their weighted swing arms at cold shutdown per 1OST-1.10.

COLD SHUTDOWN JUSTIFICATION 17**Valve No.:**

TV-1CC-111A1
TV-1CC-111A2
TV-1CC-111D1
TV-1CC-111D2

Category A**Class** 2**Function:**

Containment isolation valve for CRDM shroud cooler cooling water supply.

Test Requirement:

Quarterly full stroke and time.

Basis for CSJ:

This valve is normally open during power operation and is required to close to fulfill its safety function upon a CIB signal. Full- or part-stroke testing of this valve and isolating cooling water while the control or shutdown rods are energized, or the plant is above 250 degrees Fahrenheit, would result in component damage.

Alternate Test:

Full-stroke exercise and time closed at cold shutdown per 1OST-1.10.

COLD SHUTDOWN JUSTIFICATION 18**Valve No.:**

1CCR-247

1CCR-248

1CCR-251

1CCR-252

Category A**Class** 2**Function:**

Outside containment isolation for component cooling water supply to the RHR heat exchangers.

Test Requirement:

Quarterly full stroke.

Basis for CSJ:

These valves are normally closed during power operation but are required to open to place the residual heat removal (RHR) system in service. These valves cannot be stroked quarterly without the possibility of violating containment integrity.

Alternate Test:

Full-stroke exercise open during cold shutdowns per Operating Manual Chapter 10.4.A, "Startup of the RHR System".

COLD SHUTDOWN JUSTIFICATION 19**Valve No.:**

TV-1CC-110E2

TV-1CC-110E3

TV-1CC-110D

TV-1CC-110F2

Category A**Class** 2**Function:**

Cooling water supply and return from the containment air recirculation cooling coils and instrument air compressors containment isolation valves.

Test Requirement:

Quarterly full stroke and time.

Basis for CSJ:

These valves are normally open during power operations. The failure of any one of these valves in its closed position during quarterly stroke testing would result in the loss of containment cooling and containment instrument air and require a plant shutdown.

Alternate Test:

Full-stroke exercise and time closed at cold shutdown per 1OST-1.10.

COLD SHUTDOWN JUSTIFICATION 20**Valve No.:**

TV-1CC-130

TV-1CC-132

Category B**Class** 3**Function:**

Cooling water inlet isolation valves to the Seal Water and Non-Regenerative heat exchangers

Test Requirement:

Quarterly full stroke and time.

Basis for CSJ:

These valves are normally open during power operations and must be stroked closed to test them. Their failure in the closed position would result in the loss of cooling water to either the Seal Water or Non-Regenerative heat exchanger causing an undesirable temperature transient. Such a transient has the potential for damaging the plant demineralizers and the RCP radial bearings.

Alternate Test:

Full-stroke exercise and time closed at cold shutdowns per 1OST-1.10.

COLD SHUTDOWN JUSTIFICATION 21**Valve No.:**

1MS-15

1MS-16

1MS-17

Category B**Class** 2**Function:**

S/G Supply to 1FW-P-2 manual isolation.

Test Requirement:

Quarterly full stroke.

Basis for CSJ:

These valves will be stroked quarterly except in the event of a steam generator tube leak. In this case, the valve from the affected steam generator must remain closed to prevent the spread of radioactivity into the auxiliary feed system.

Alternate Test:

Full-stroke exercise [1MS-15, 16] closed and [1MS-17] open quarterly per 1OST-24.4 or during cold shutdowns per 1OST-24.9.

COLD SHUTDOWN JUSTIFICATION 22**Valve No.:**

NRV-1MS-101A
NRV-1MS-101B
NRV-1MS-101C

Category B/C**Class** 2**Function:**

Main steam non-return check valves.

Test Requirement:

Quarterly full stroke.

Basis for CSJ:

Full- or part-stroke testing these valves at power is not possible because these valves must be open in order to remain at power.

Alternate Test:

Full-stroke exercise closed at cold shutdown per 1OST-1.10.

COLD SHUTDOWN JUSTIFICATION 23**Valve No.:**

PCV-1MS-101A
PCV-1MS-101B
PCV-1MS-101C

Category B**Class** 2**Function:**

Atmospheric steam dump pressure control valves.

Test Requirement:

Quarterly full stroke and time.

Basis for CSJ:

In order to test these valves, manual isolation valves must first be closed. The manual valves are located in a potentially hazardous area and could be damaged when they are reopened against a 1000 psi Δp . Also, full or partial stroking the PCV valves at power could cause Reactor power transients.

Alternate Test:

Full-stroke exercise and time open at cold shutdown per 1OST-1.10.

COLD SHUTDOWN JUSTIFICATION 24**Valve No.:**

TV-1MS-101A

TV-1MS-101B

TV-1MS-101C

Category B/C**Class** 2**Function:**

Main steam line isolation valves (pneumatically opened).

Test Requirement:

Quarterly full stroke and time.

Basis for CSJ:

These valves are normally open at power but must close in the event of a high energy line break. Stroking these valves fully closed during full power operation would cause a reactor trip with the possibility of a safety injection. A review of plant history also indicates that several forced plant shutdowns have resulted from part-stroke testing these valves at power due to their inadvertent closure for reasons not related to valve operability. For these reasons, full- and part-stroke testing is not considered practical and will not be performed. This change is consistent with Technical Specification Amendment No. 162.

Alternate Test:

Full-stroke exercise and time closed in hot standby with $T_{avg} \geq 515^{\circ}\text{F}$ per 10ST-21.4, 5 and 6.

COLD SHUTDOWN JUSTIFICATION 25

Valve No.:

1FW-33	1FW-42	1FW-622	1FW-625
1FW-34	1FW-43	1FW-623	1FW-626
1FW-35	1FW-44	1FW-624	1FW-627

Category CClass 3

Function: Auxiliary feedwater pumps discharge and loop check valves.

Test Requirement: Quarterly full stroke.

Basis for CSJ: The safety position for these check valves is open for auxiliary feed system injection and closed to provide header separation in the event of a linebreak. These valves cannot be stroked at power due to the thermal shock at the auxiliary and main feedwater interface caused by the sudden injection of cold water into the steam generators. Also, feeding the steam generators with cold water would result in large level transients.

Alternate Test: All valves are full-stroke exercised in the forward direction at cold shutdowns per either 1OST-24.8 or 9. Valves [1FW-33 thru 35] and [1FW-622 thru 627] are full-stroke exercised in the reverse direction at cold shutdowns per 1OST-24.8. Reverse direction testing of [1FW-42 thru 44] will be by monitoring upstream pipe temperatures at least quarterly and by leak test per 1OST-24.11 at refuelings.

COLD SHUTDOWN JUSTIFICATION 26**Valve No.:**

MOV-1FW-156A
MOV-1FW-156B
MOV-1FW-156C

Category B/C**Class** 2**Function:**

A, B and C loop feedwater containment isolation check valves.

Test Requirement:

Quarterly full stroke and time.

Basis for CSJ:

Stroke testing these valves during power operation could cause a loss of feedwater resulting in a reactor trip. Also, the motor operator associated with these valves will only operate with a very small or no differential pressure across the valve. It is not for use at power.

Alternate Test:

Full-stroke exercise and time closed at cold shutdown per 1OST-1.10, and as an additional test of the check valve verify closure by a leak test per 1OST-24.14A, B, and C at refuelings.

COLD SHUTDOWN JUSTIFICATION 27**Valve No.:**

1FP-800

1FP-804

1FP-827

Category A/C**Class** 2**Function:**

Fire protection, deluge system to RHR area, to cable penetration area and to containment hose reels inside containment check valves.

Test Requirement:

Quarterly full stroke.

Basis for CSJ:

These valves are normally closed during power operation and are only required to open in the event fire protection water is needed. Full and part stroke exercising is not possible during power operation due to the inaccessibility of the valves.

Alternate Test:

Full-stroke exercise open and closed by mechanical exerciser utilizing their weighted swing arms at cold shutdown per 1OST-1.10.

COLD SHUTDOWN JUSTIFICATION 28**Valve No.:**

1VS-D-5-3A

1VS-D-5-3B

1VS-D-5-5A

1VS-D-5-5B

Category A**Class** 2**Function:**

Containment isolation valves for refueling purge and exhaust lines.

Test Requirement:

Quarterly full stroke and time.

Basis for CSJ:

These dampers are shut during power operation and are required to remain shut to fulfill their safety function. These dampers cannot be full or part-stroke exercised during power operation without violating containment integrity.

Alternate Test:

Full-stroke exercise and time closed at cold shutdown per 1OST-1.10.

COLD SHUTDOWN JUSTIFICATION 29

Valve No.:

FCV-1FW-478

FCV-1FW-488

FCV-1FW-498

Category BClass 2

Function:

Steam Generator main feedwater regulating valves.

Test Requirement:

Quarter to full stroke and time.

Basis for CSJ:

Valves are normally closed during power operation. Their safe operation is required for feedwater isolation. Full stroke and time testing cannot be performed at power since this would isolate feedwater flow to the steam generators resulting in a plant trip and shutdown.

Alternate Test:

Full-stroke exercise and time closed at cold shutdown per 10ST-1.10.

COLD SHUTDOWN JUSTIFICATION 30

DELETED

COLD SHUTDOWN JUSTIFICATION 31**Valve No.:**

MOV-1FW-150A
MOV-1FW-150B

Category B**Class** 3**Function:**

Main feedwater pump discharge isolation and backup feedwater isolation.

Test Requirement:

Quarterly full stroke and time.

Basis for CSJ:

During plant operation, these valves are open to supply feedwater flow to the steam generators. Their safety function is to close for backup feedwater isolation. Full-stroke and time testing cannot be performed at power since this would isolate feedwater resulting in a plant trip and shutdown.

Alternate Test:

Full-stroke exercise and time closed at cold shutdown per 1OST-1.10.

COLD SHUTDOWN JUSTIFICATION 32**Valve No.:**

MOV-1SI-867A
MOV-1SI-867B

Category B**Class** 2**Function:**

Boron Injection Tank (BIT) inlet isolation valves.

Test Requirement:

Quarterly full stroke and time.

Basis for CSJ:

These valves are shut at power but are required to open to fulfill their safety function in the event of a safety injection. Stroking these valves fully or partially at power has historically caused leakage past the BIT manway flange and the other valves in the system. In addition, stroking these valves would dilute the boron concentration of the BIT, potentially causing entry into a technical specification action statement.

Alternate Test:

Full-stroke exercise and time open during cold shutdown per 1OST-1.10.

SECTION VII: VALVE TESTING RELIEF REQUESTS

RELIEF REQUEST 1

Valve No.: See list of Containment Isolation Valves on next page.

Category A or A/C **Class** 2

Function: Containment Isolation

Test Requirement: Leak tested per IWV-3420 at least once every 2 years.

Basis for Relief: These containment isolation valves are leak tested in accordance with 10CFR50, Appendix J, Type C. Since the acceptance criteria for Appendix J, Type C is more limiting than ASME Section XI, additional leak testing in accordance with ASME Section XI would be redundant.

Alternate Test: Leak tested during refueling outages in accordance with 10CFR50, Appendix J, IWV-3426, and IWV-3427(a) per 1BVT 1.47.5. The additional requirements of IWV-3427(b) for valves six inches or larger will not be followed. The usefulness of IWV-3427(b) does not justify the burden of complying with this requirement. Unnecessary repair or replacement of a valve or additional leak testing, if attempted at cold shutdown, could delay plant startup. Per 10CFR50.55a(a)(3)(ii) compliance with the specified requirements of IWV-3427(b) would result in hardship or unusual difficulties without a compensating increase in the level of quality and safety. For the valves listed on the next page of this relief request, an asterisk to the left of the valve mark number indicates its size as six inches or larger. As a special test, after maintenance has been performed on any Type C relief valve, 1BVT 2.47.2 may also be performed to leak test the valve in lieu of 1BVT 1.47.5.

RELIEF REQUEST 1 Containment Isolation Valves

*MOV-1CC-112A2	TV-1CC-107E1	TV-1SS-109A2	1HY-101
*1CCR-247	TV-1CC-107E2	TV-1LM-100A1	TV-1CV-150A
*MOV-1CC-112F3	TV-1CC-105E1	TV-1LM-100A2	*HY-103
*1CCR-252	TV-1CC-105E2	TV-1SS-111A1	*HCV-1CV-151
*MOV-1CC-112A3	TV-1CH-200A	TV-1SS-111A2	*HCV-1CV-151-1
*1CCR-251	TV-1CH-200B	TV-1SS-100A1	SOV-1HY-102B1
*MOV-1CC-112B2	TV-1CH-200C	TV-1SS-100A2	SOV-1HY-102B2
*1CCR-248	RV-1CH-203	TV-1SS-102A1	SOV-1HY-103B1
TV-1CC-107D1	MOV-1CH-142	TV-1SS-102A2	SOV-1HY-103B2
TV-1CC-107D2	TV-1CH-204	TV-1SS-105A1	SOV-1HY-104B1
*TV-1CC-111D1	TV-1DG-108A	TV-1SS-105A2	SOV-1HY-104B2
*TV-1CC-111D2	TV-1DG-108B	*TV-1CC-103A1	TV-1SS-104A1
*TV-1CC-110D	1FP-804	*TV-1CC-103A	TV-1SS-104A2
*TV-1CC-110F1	TV-1FP-105	*1QS-4	TV-1SS-103A1
*TV-1CC-110F2	1FP-800	*MOV-1QS-101B	TV-1SS-103A2
1FP-827	TV-1FP-106	*1QS-3	*1PC-38
TV-1FP-107	TV-1DA-100A	*MOV-1QS-101A	*1PC-37
*TV-1CC-110E3	TV-1DA-100B	*1RS-101	*1PC-9
*TV-1CC-110E2	1SA-15	*1RS-100	*1PC-10
*TV-1CC-111A2	1SA-14	1HY-196	TV-1SS-112A1
*TV-1CC-111A1	TV-1CV-102-1	1HY-111	TV-1SS-112A2
*TV-1CC-103B1	TV-1CV-102	1HY-197	MOV-1SI-842
*TV-1CC-103B	TV-1CV-101A	1HY-110	TV-1SI-889
*TV-1CC-103C1	TV-1CV-101B	*AS-278	SOV-1HY-102A1
*TV-1CC-103C	1RC-72	*TV-1SV-100A	SOV-1HY-102A2
MOV-1CH-378	TV-1RC-519	*VS-D-5-3B	SOV-1HY-103A1
1CH-369	11A-91	*VS-D-5-3A	SOV-1HY-103A2
MOV-1CH-381	11A-90	*VS-D-5-5B	SOV-1HY-104A1
1SI-42	TV-1DG-109A2	*VS-D-5-5A	SOV-1HY-104A2
1SI-41	TV-1DG-109A1	*VS-D-5-6	1RC-277
*1RH-14	1RC-68	TV-1CV-150C	1RC-278
1RH-16	TV-1RC-101	1HY-102	1VS-169
*1RH-15	TV-1SI-101-2	TV-1CH-150D	1VS-170
*TV-1CC-105D1	TV-1SI-101-1	1HY-104	1VS-167
*TV-1CC-105D2	TV-1SS-109A1	TV-1CV-150B	1VS-168

* Indicates valve size six inches or larger.

RELIEF REQUEST 2

Valve No.:

1RC-68

Category A/C Class 2

Function:

Inside containment isolation on the N₂ makeup line to the Pressurizer Relief Tank.

Test Requirement:

Quarterly full stroke.

Basis for Relief:

This valve is normally closed and is opened only during nitrogen makeup to the Pressurizer Relief Tank. Its safety position is closed for containment isolation. The only means for verifying closure is during the 10CFR50, Appendix J leak rate test performed at refuelings.

Alternate Test:

Valve closure is verified by a leak test during refueling outages per 1BVT 1.47.5.

RELIEF REQUEST 3

Valve No.:

1RC-72

Category A/C Class 2

Function:

Inside containment isolation on the primary grade water supply to the Pressurizer Relief Tank.

Test Requirement:

Quarterly full stroke.

Basis for Relief:

This valve is normally closed and is opened only during makeup to or while depressurizing the Pressurizer Relief Tank. Its safety position is closed for containment isolation. The only means for verifying closure is during the 10CFR50, Appendix J leak rate test performed at refuelings.

Alternate Test:

Valve closure is verified by a leak test during refueling outages per 1BVT 1.47.5.

RELIEF REQUEST 4**Valve No.:**

1CH-22

1CH-23

1CH-24

Category C**Class** 2**Function:**

Normal pump discharge check valves for the charging pumps.

Test Requirement:

Quarterly full stroke.

Basis for Relief:

The design function of these check valves is to prevent reverse flow during pump shutdown and to stroke full open for safety injection flow. A full design flow test is required to ensure full stroke. However, during normal operation, the charging pump will not develop the required flow. Therefore, relief from quarterly full-stroke exercising is requested during normal operation. Relief is also requested from cold shutdown full-stroke exercising because full flow testing could result in a low temperature overpressurization of the RCS.

Alternate Test:

Part-stroke exercised open and full-stroke exercised closed quarterly per 1OST 7.4, 5 and 6. Full-stroke exercise open during refueling outages per 1OST-11.14.

RELIEF REQUEST 5**Valve No.:**

1CH-31

Category A/C**Class** 2**Function:**

Charging header inside containment isolation check valve.

Test Requirement:

Quarterly full stroke.

Basis for Relief:

This normally open check valve must close to fulfill its safety function. Valve closure can only be checked by a leak test and there is no instrumentation to monitor upstream pressure. Therefore, relief is requested from quarterly and cold shutdown stroke tests.

Alternate Test:

Valve closure is verified by a leak test during refueling outages per 1BVT 1.47:11.

RELIEF REQUEST 6**Valve No.:**

1CH-181

1CH-182

1CH-183

Category A/C**Class** 2**Function:**

Reactor coolant seal injection inside containment isolation check valves.

Test Requirement:

Quarterly full stroke.

Basis for Relief:

These valves are open during power operation but are required to close to fulfill their safety function. Closing the valves during power operation, or anytime the system is pressurized to greater than 100 psig, would secure seal injection water to the reactor coolant pump seals, resulting in seal damage. In addition, valve closure can only be checked by leak testing since they have no position indication or weighted arms. Therefore, relief is requested from quarterly and cold shutdown exercising.

Alternate Test:

Valve closure is verified by a leak test during refueling outages per 1BVT 1.47.11.

RELIEF REQUEST 7**Valve No.:**

TV-1CH-200A

TV-1CH-200B

TV-1CH-200C

Category A**Class** 2**Function:**

Reactor coolant letdown orifice inside containment isolation valves.

Test Requirement:

IWV-3426 and 3427(a) require Owner specified maximum permissible leakage rates for specific valves as a function of valve size and type and provide the corrective action to be followed when these limits are exceeded.

Basis for Relief:

As shown on the attached figure for penetration #28, the configuration of this containment penetration (i.e. three inside containment isolation valves in parallel) is such that individual leakage rates for each specific valve cannot be determined using the test method of 10CFR50, Appendix J. In this case, assigning maximum permissible leakage rates for each valve would not be practical.

Alternate Test:

Assign a maximum permissible leakage rate for the entire barrier to then be used as the criteria for initiating corrective action in accordance with IWV-3427(a).

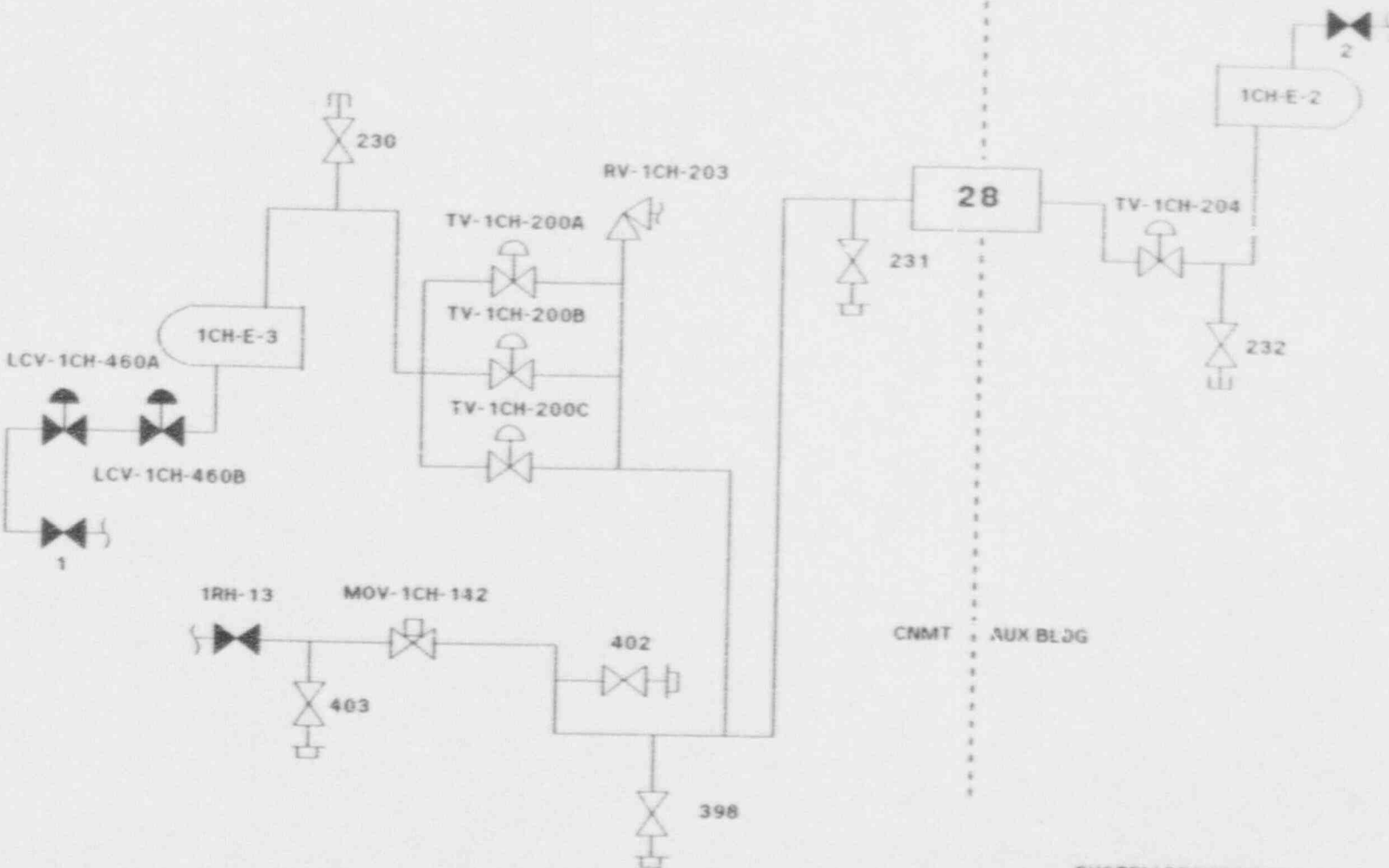

PENETRATION # 28

SYSTEM DESIGNATION
(1CH)

RELIEF REQUEST 7

RELIEF REQUEST 8**Valve No.:**

1CH-369

Category A/C**Class** 2**Function:**

Penetration 19 pressure relief check around [MOV-1CH-378]

Test Requirement:

Quarterly full stroke.

Basis for Relief:

This valve is normally closed during power operation and is required to remain closed to fulfill its safety function. Full stroking can only be verified by the leak test. Therefore, relief is requested from quarterly and cold shutdown stroke tests.

Alternate Test:

Valve closure is verified by a leak test during refueling outages per 1BVT 1.47.5.

RELIEF REQUEST 9 **Valve No.:**

MOV-1CH-378
1CH-369

Category A; A/C **Class** 2 **Function:**

RCP seal water return line inside containment isolation valves.

Test Requirement:

IWV-3426 and 3427(a) require Owner specified maximum permissible leakage rates for specific valves as a function of valve size and type and provide the corrective action to be followed when these limits are exceeded.

Basis for Relief:

As shown on the attached figure for penetration #19, the configuration of this containment penetration (i.e. two inside containment isolation valves in parallel) is such that individual leakage rates for each specific valve cannot be determined using the test method of 10CFR50, Appendix J. In this case, assigning maximum permissible leakage rates for each valve would not be practical.

Alternate Test:

Assign a maximum permissible leakage rate for the entire barrier to then be used as the criteria for initiating corrective action in accordance with IWV-3427(a).

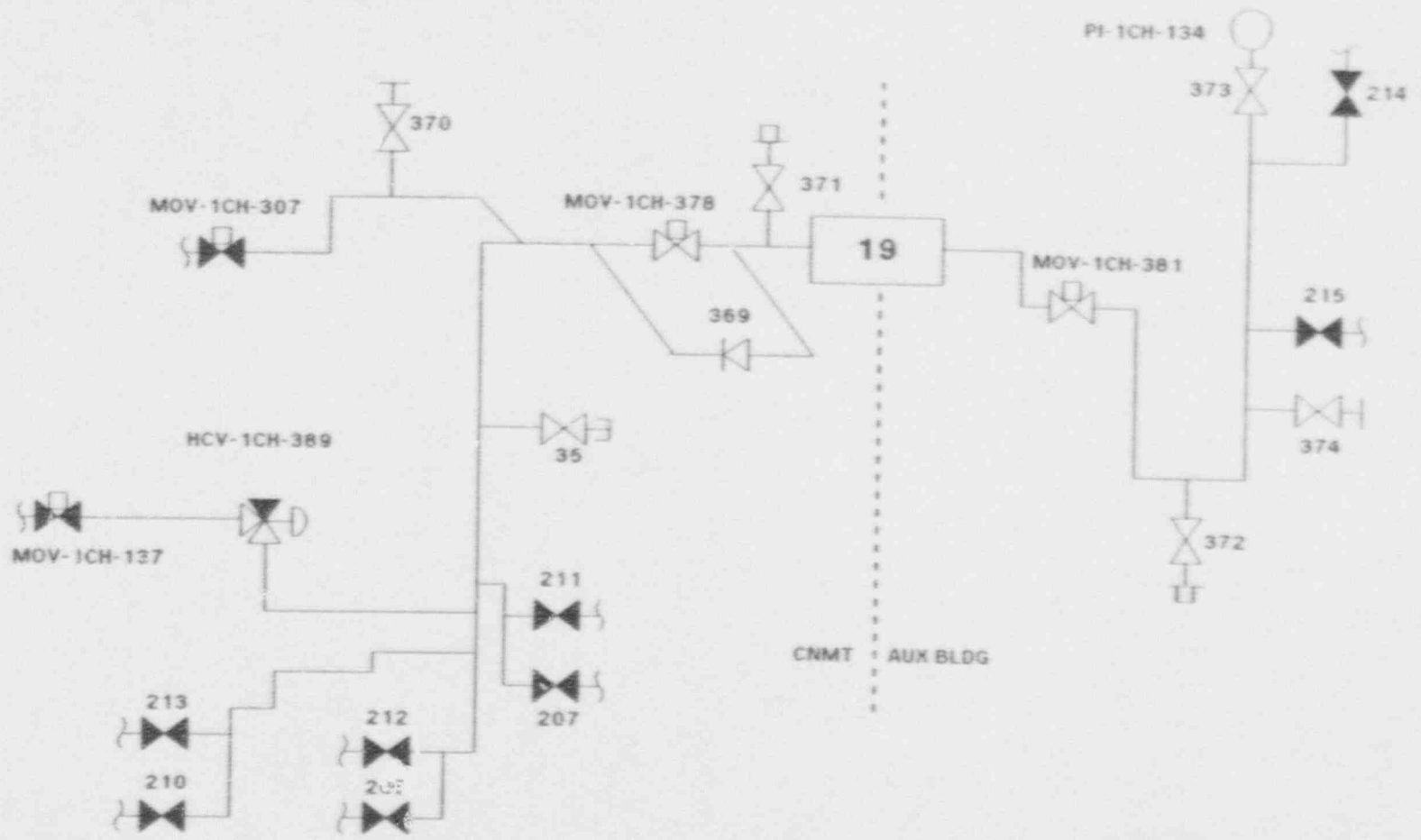

SYSTEM DESIGNATION
 (1CH)

PENETRATION # 19

RELIEF REQUEST 10**Valve No.:**

MOV-1CH-308A
MOV-1CH-308B
MOV-1CH-308C

Category A**Class** 2**Function:**

Reactor Coolant Seal Injection outside containment isolation motor-operated valves.

Test Requirement:

Quarterly full stroke and time.

Basis for Relief:

These valves are open during power operation but are required to close to fulfill their safety function. Closing the valves during power operation would secure seal injection water to the reactor coolant pump seals, resulting in seal damage. In addition, seal injection flow is required anytime the system is pressurized to greater than 100 psig.

Alternate Test:

The MOVs will be full-stroke exercised and timed closed during cold shutdowns when RCS pressure has been reduced to below 100 psig, and at refueling outages per 1OST-1.10.

RELIEF REQUEST 11**Valve No.:**

MOV-1CH-370

Category B**Class** 2**Function:**

Charging supply isolation to Reactor Coolant Pump Seal Injection.

Test Requirement:

Quarterly full stroke and time.

Basis for Relief:

This valve is normally open during power operation. Closing it during power operation would secure seal injection water to the reactor coolant pump seals, resulting in seal damage. In addition, seal injection flow is required any time the system is pressurized to greater than 100 psig.

Alternate Test:

Full-stroke exercise and time closed during cold shutdowns when RCS pressure has been reduced to below 100 psig, and at refueling outages per 1OST-1.10.

RELIEF REQUEST 12**Valve No.:**

MOV-1CH-378
MOV-1CH-381

Category A**Class** 2**Function:**

RCP seal water return line inside and outside containment isolation valves.

Test Requirement:

Quarterly full stroke and time.

Basis for Relief:

These valves are open during power operation, but are required to close to fulfill their safety function. Exercising at power would secure RCP seal water return causing seal damage. In addition, seal injection flow is required any time the RCS is pressurized to greater than 100 psig.

Alternate Test:

Full-stroke exercised and time closed during cold shutdowns when RCS pressure has been reduced to below 100 psig, and at refueling outages per 1OST-1.10.

RELIEF REQUEST 13**Valve No.:**

1SI-1
1SI-2

Category C**Class** 2**Function:**

LHSI pump suction check valves from the containment sump.

Test Requirement:

Quarterly full stroke.

Basis for Relief:

These valves are normally closed during power operation but must open to fulfill their safety function for long-term core cooling. Any type of stroke testing at power would violate containment integrity. Due to the lack of installed or test instrumentation and the impracticality of simulating actual safety injection long-term cooling, relief from quarterly and cold shutdown exercising is requested.

Alternate Test:

Maintenance is to disassemble and inspect one valve per refueling outage per 1CMP-75-ALOYCO CHECK-1M.

RELIEF REQUEST 14**Valve No.:**

1SI-5

Category C**Class** 2**Function:**

LHSI pump suction check valve from the RWST.

Test Requirement:

Quarterly full stroke.

Basis for Relief:

The function of this normally closed valve is to open to permit flow from the RWST to the LHSI pump suction. Full stroke capability can only be verified by rated safety injection flow, therefore, relief is requested from quarterly full-stroke exercising. Relief from cold shutdown full-stroke exercising is also requested because testing would require full flow injection to the RCS where there is insufficient volume to receive the additional inventory.

Alternate Test:

Part-stroke exercised quarterly in the open direction per 1OST-11.1 and 2. Full-stroked exercised open at refueling outages per 1OST-11.14.

RELIEF REQUEST 15

Valve No.:

1SI-6

1SI-7

Category CClass 2

Function:

LHSI pump discharge check valves.

Test Requirement:

Quarterly full stroke.

Basis for Relief:

These valves close when the opposite LHSI pump is operating to prevent damaging the non-running pump seals and pump suction piping, but must be fully open during an accident. These valves are part-stroked open and full-stroked closed during the quarterly pump surveillance tests; however, rated safety injection flow is needed to verify full stroke capability. Relief from stroking to the full open position at power is requested due to the inability of the LHSI pumps to overcome RCS pressure. Relief from cold shutdown stroking is also requested because testing would require full flow injection to the RCS where there is insufficient volume to receive the additional inventory.

Alternate Test:

Part-stroke exercised quarterly in the open direction per 1OST-11.1 and 2. Full-stroke exercised open at refueling outages per 1OST-11.14.

RELIEF REQUEST 16**Valve No.:**

1SI-10

1SI-11

1SI-12

Category A/C**Class** 1**Function:**

LHSI cold leg branch line check valves.

Test Requirement:

Quarterly full stroke.

Basis for Relief:

These check valves are normally shut to prevent reverse flow from the higher pressure RCS and HHSI system to the LHSI low pressure system during power operation but are required to open in the event of a safety injection. Due to the lack of installed instrumentation, and the relative system pressures, relief from quarterly full and part-stroke exercising is requested. In addition, relief is requested from full or part-stroke exercising at cold shutdown because testing would require full flow injection to the RCS where there is insufficient volume to receive the additional inventory.

Alternate Test:

Full-stroke exercised open per 1OST-11.14 and reverse flow exercised closed by leak test per 1OST-11.16 during refueling outages

RELIEF REQUEST 17**Valve No.:**

1SI-20
1SI-21
1SI-22
1SI-100
1SI-101
1SI-102

Category C**Class** 1**Function:**

SI hot and cold leg branch line check valves.

Test Requirement:

Quarterly full stroke.

Basis for Relief:

The safety function for these valves is to open in the event of a safety injection. These check valves cannot be full or part-stroked open at power at any frequency due to the potential for a premature failure of the injection nozzles caused by the thermal shock from a cold water injection. Relief from stroke testing at cold shutdowns is also requested since this could result in a low temperature overpressurization of the RCS.

Alternate Test:

Full-stroke exercised open per 1OST-11.14 during refueling outages.

RELIEF REQUEST 18**Valve No.:**

1SI-23

1SI-24

1SI-25

Category A/C**Class** 1**Function:**

SI cold leg branch line check valves.

Test Requirement:

Quarterly full stroke.

Basis for Relief:

These check valves are normally shut during power operation to prevent reverse flow from the higher pressure RCS to the lower pressure LHSI system but are required to open in the event of a safety injection. Due to the lack of installed instrumentation, the relative system pressures and the potential for a premature failure of the injection nozzles caused by the thermal shock from a cold water injection, relief from quarterly full or part-stroke testing at power is requested. In addition, relief from cold shutdown stroke testing is requested since this would require a full flow injection to the RCS where there is insufficient volume to receive the additional inventory.

Alternate Test:

Full-stroke exercised open per 1OST-11.14 during refueling outages and reverse-flow exercised closed by leak per 1OST-11.16 during refueling outages.

RELIEF REQUIST 19

Valve No.:

1SI-27

Category CClass 2

Function:

High head safety injection pump suction from RWST check valve.

Test Requirement:

Quarterly full stroke.

Basis for Relief:

This valve is normally closed during power operation but is required to open at the onset of an accident to fulfill its safety function. A full design flow test is required to ensure full stroke. However, during normal operation the charging pump will not develop the required flow. Therefore, relief from quarterly full-stroke exercising is requested during normal operation. Relief is also requested from cold shutdown exercising because full-flow testing could result in low-temperature overpressurization of the RCS.

Alternate Test:

Part-stroke exercised open quarterly if the RWST is supplying the charging pumps per 1OST-7.4, 5 and 6. Full-stroked exercised open during refueling outages per 1OST-11.14.

RELIEF REQUEST 20**Valve No.:**

1SI-48

1SI-49

1SI-50

1SI-51

1SI-52

1SI-53

Category A/C**Class** 1**Function:**

Safety injection accumulator series discharge check valve.

Test Requirement:

Quarterly full stroke.

Basis for Relief:

These valves are shut during normal power operation but are required to open to fulfill their safety function of allowing the accumulators to discharge for core flooding. Relief from full or part-stroke exercising at power is requested due to the high pressure differential between the reactor coolant system and the accumulators. Relief from exercising during cold shutdown is also requested due to a lack of installed instrumentation and an uncontrolled test volume change needed to achieve the flow required by the safety analysis.

Alternate Test:

Full-stroke exercised open during refueling outages per 1BVT 1.11.3. As a special test, after maintenance has been performed on any of these valves, 1OST-11.15 may be performed to partial-stroke exercise the applicable valve.

RELIEF REQUEST 21**Valve No.:**

1SI-83

1SI-84

Category A/C**Class** 2**Function:**

HHSI hot leg branch line inside containment isolation check valves.

Test Requirement:

Quarterly full stroke.

Basis for Relief:

These valves are normally shut but are required to open to fulfill their safety function to provide long-term recirculation in the event of a safety injection. They cannot be full or part-stroked open at power due to the potential for a premature failure of the injection nozzles caused by the thermal shock from a cold water injection. Cold shutdown full-stroke testing cannot be performed since this could result in a low temperature overpressurization of the RCS.

Alternate Test:

Full-stroke exercised open during refueling outages per 1OST-11.14.

RELIEF REQUEST 22

Valve No.:

1SI-94

1SI-95

Category A/CClass 2

Function:

BIT injection and SI fill header line inside containment isolation check valves.

Test Requirement:

Quarterly full stroke.

Basis for Relief:

These valves are normally shut during power operation but are required to open to fulfill their safety function in the event of a safety injection. These check valves cannot be full or part-stroked at power at any frequency due to the potential for a premature failure of the injection nozzles caused by the thermal shock from a cold water injection. Relief from stroke testing at cold shutdowns is also required since cold result in a low temperature overpressurization of the RCS.

Alternate Test:

Full-stroke exercised open during refueling outages per 10ST-11.14.

RELIEF REQUEST 23

DELETED

RELIEF REQUEST 24**Valve No.:**

MOV-1SI-867C

MOV-1SI-867D

Category A**Class** 2**Function:**

Boron Injection Tank (BIT) outlet isolation and outside containment isolation valves.

Test Requirement:

Quarterly full stroke and time.

Basis for Relief:

These valves are shut at power but are required to open to fulfill their safety function in the event of a safety injection. Quarterly stroking of these valves to their open safety position could result in some borated, oxygenated water from the BIT entering the piping downstream of these valves. With no means to flush out these lines, valve closure would then cause a stagnant condition to develop. IE Bulletin 79-17 has identified the combination of these three factors as one which promotes intergranular stress corrosion cracking (IGSCC). The ability to flush out the downstream piping to minimize the probability of IGSCC formation is only possible during refueling outages in conjunction with the SI full flow test, 1OST-11.14. Therefore, relief is requested from quarterly stroke testing.

Alternate Test:

Full-stroke exercised and timed open during refueling outages per 1OST-11.14.

RELIEF REQUEST 25**Valve No.:**

1RS-158

1RS-160

Category C**Class** 2**Function:**LHSI pump and Outside RS pump cross connection check
es.**Test Requirement:**

Quarterly full stroke.

Basis for Relief:

These valves are normally closed during power operation but must open to fulfill their safety function in the unlikely event that the LHSI pumps are unable to supply the HHSI pumps. No practical method of testing these valves exists. The volume of water used to test the outside RS pumps is insufficient to stroke the check valves even if it could be directed to the suction of the LHSI pumps. In addition, there is no installed instrumentation. Therefore, relief from quarterly and cold shutdown exercising is requested.

Alternate Test:

Maintenance is to disassemble and inspect one valve per refueling outage per CMP 1/2-75-VELAN CHECK-1M.

RELIEF REQUEST 26**Valve No.:**

TV-1CC-103A	TV-1CC-103C1	TV-1CC-105E2	TV-1CC-107D1
TV-1CC-103A1	TV-1CC-105D1	TV-1CC-107A	TV-1CC-107D2
TV-1CC-103B	TV-1CC-105D2	TV-1CC-107B	TV-1CC-107E1
TV-1CC-103B1	TV-1CC-105E1	TV-1CC-107C	TV-1CC-107E2
TV-1CC-103C			

Category A,B**Class** 2,3

Function: Component cooling to reactor coolant pump, stator, bearing and thermal barrier isolation valves.

Test Requirement: Quarterly full stroke and time.

Basis for Relief: Stroking these valves with the reactor coolant pumps running could cause damage to pump bearings, stator and thermal barrier if the valves would fail to reopen. Relief is requested from full- or part-stroke exercising during power operation and cold shutdown when the pump is running.

Alternate Test: Full-stroke exercised and timed closed during cold shutdowns when the reactor coolant pumps are secured, and during refueling outages per 1OST-1.10.

RELIEF REQUEST 27**Valve No.:**

TV-1CC-110F1

TV-1CC-110F2

Category A passive; A **Class** 2**Function:**

Outside containment isolation cooling water return from the containment air recirculation cooling coils to the Chilled Water and River Water Systems.

Test Requirement:

IWV-3426 and 3427(a) require Owner specified maximum permissible leakage rates for specific valves as a function of valve size and type and provide the corrective action to be followed when these limits are exceeded.

Basis for Relief:

As shown on the attached figure for Penetration #11, the configuration of this containment penetration (i.e., two outside containment isolation valves in parallel) is such that individual leakage rates for each specific valve cannot be determined using the test method of 10CFR50, Appendix J. In this case, assigning maximum permissible leakage rates for each valve would not be practical.

Alternate Test:

Assign a maximum permissible leakage rate for the entire barrier to then be used as the criteria for initiating corrective action in accordance with IWV-3427(a).

RELIEF REQUEST 27

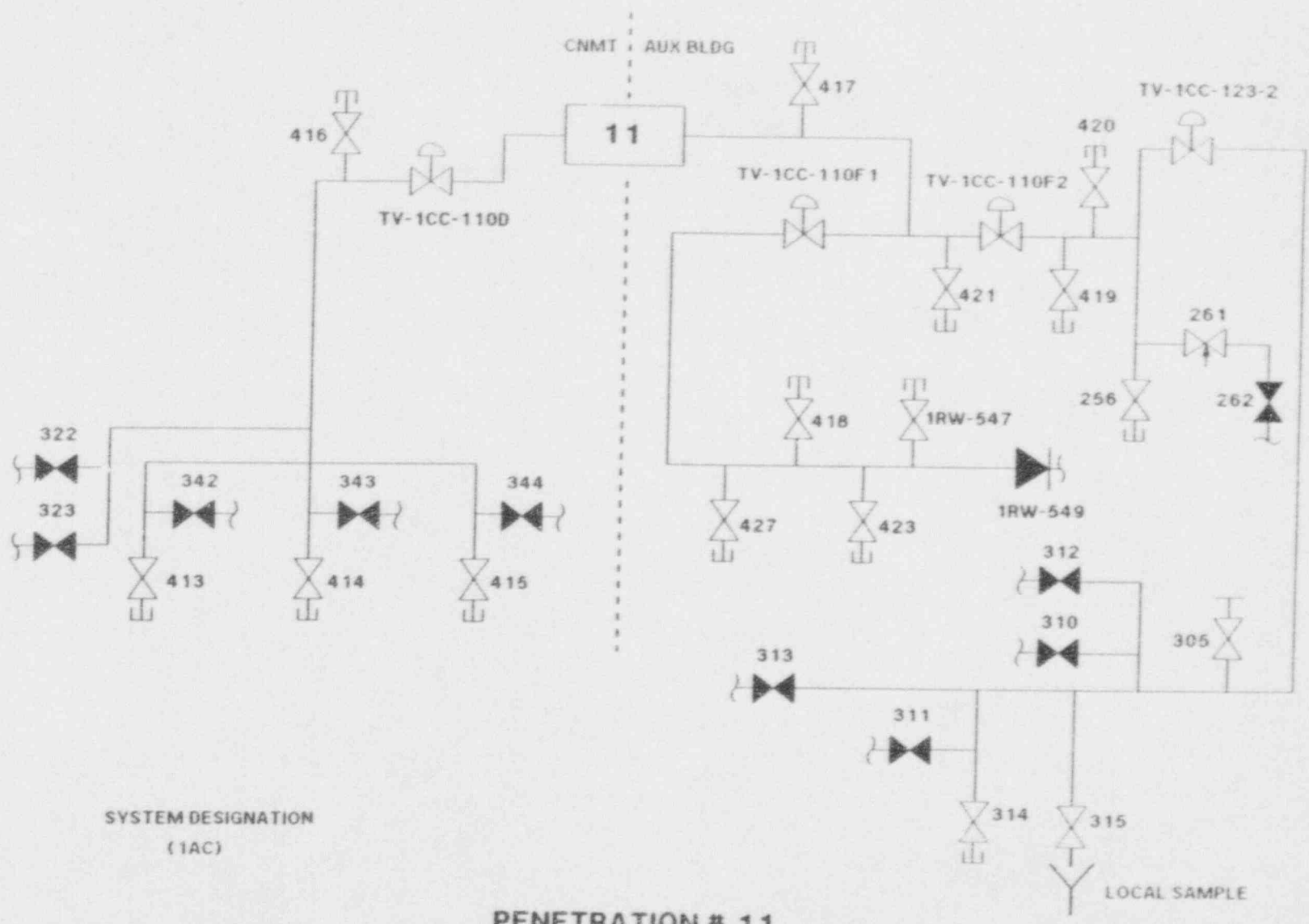

SYSTEM DESIGNATION
 (1AC)

PENETRATION # 11

RELIEF REQUEST 28**Valve No.:**

1CCR-289

1CCR-290

1CCR-291

Category C**Class** 3**Function:**

Reactor coolant pump thermal barrier supply check valves.

Test Requirement:

Quarterly full stroke.

Basis for Relief:

The safety function of these valves is to close to prevent reverse flow to the low pressure CCR system in the event a thermal barrier leaks. The only way to test for closure is to perform a leak test on the valves or by valve disassembly and inspection. Therefore, relief is requested from quarterly and cold shutdown stroke tests.

Alternate Test:

Valve closure is verified by a leak test at refueling outages per 1BVT 1.60.7.

RELIEF REQUEST 29**Valve No.:**

1MS-18

1MS-19

1MS-20

Category C**Class** 2**Function:**

Main steam to auxiliary feed pump check valves.

Test Requirement:

Quarterly full stroke.

Basis for Relief:

The function of these valves is to open to allow steam flow to run the turbine-driven auxiliary feedwater pump and to close to prevent steam generator cross connection in the event of a high energy line break. A full-stroke to the opened position can only be verified by a full-flow test of the turbine-driven auxiliary feedwater pump performed during startup from cold shutdown. The quarterly pump test runs the pump on recirculation only and does not require full steam flow. A full-stroke to the closed position can only be verified by a leak test to be performed during refueling outages.

NOTE:

To prevent the loss of all three steam generators in the event of a line break, one of the manual isolation valves upstream of the check valves is locked shut during normal operation.

Alternate Test:

Two of the valves will be part-stroke exercised open during the quarterly pump test per 1OST-24.4. The third valve will not be part-stroke exercised because the manual isolation valve is locked closed.

All three valves will be full-stroke exercised open each startup from cold shutdown when the turbine-driven auxiliary feed water pump is full flow tested per 1OST-24.9.

The valves will be full-stroke exercised closed during refueling outages by leak test per 1BVT 1.60.7.

RELIEF REQUEST 30**Valve No.:**

1MS-80

1MS-81

1MS-82

Category C**Class** 2**Function:**

The A, B and C loop residual heat release reverse flow check valves.

Test Requirement:

Quarterly full stroke.

Basis for Relief:

The safety function of these valves is to close to prevent steam generator cross connection in the event of a high energy line break. Relief is requested from at power and cold shutdown full-stroke closure testing because there is no installed instrumentation to check for reverse flow and the headers are normally cross connected and pressurized. No way exists to isolate and systematically check operation of these valves.

Alternate Test:

Maintenance is to disassemble and inspect one valve per refueling outage per 1CMP-75-CRANE CHECK-1M.

RELIEF REQUEST 31**Valve No.:**

1RW-106

1RW-107

Category C**Class** 3**Function:**

River water supply header check valves.

Test Requirement:

Quarterly full stroke.

Basis for Relief:

The safety function of these valves is to open to permit river water to safety-related components during an accident and to close if the auxiliary river water pumps are supplying the river water headers. The closure of these valves can only be verified by valve disassembly and internal inspection or by reverse flow leak testing.

Alternate Test:

Full-stroke exercised open quarterly per 1OST-30.2, 3 and 6. Full-stroke exercised closed during refueling outages in conjunction with 1OST-30.8.

RELIEF REQUEST 32**Valve No.:**

1RW-110

1RW-111

1RW-112

1RW-113

Category C**Class** 3**Function:**

Diesel generator heat exchanger river water inlet check valves.

Test Requirement:

Quarterly full stroke.

Basis for Relief:

The safety function of these valves is to permit river water flow to the diesel generator heat exchangers. In order to fulfill their function, as per IE Bulletin 83-03, the integrity of these valves must be verified. The valve integrity can only be verified through valve disassembly and internal inspection.

Alternate Test:

Part-stroke exercised open quarterly per 1OST-36.1 & 2. Full-stroke exercised in both the open and closed directions through a sample valve disassembly and inspection program per CMP 1/2-75-WAFER CHECK-1M. One to two check valves will be disassembled and inspected every refueling outage not to exceed a 5 year frequency per IE Bulletin 83-03.

RELIEF REQUEST 33

DELETED

RELIEF REQUEST 34

DELETED

RELIEF REQUEST 35

Valve No.:

1RW-675

1RW-676

1RW-677

Category CClass 3

Function:

Unfiltered river water supply to the river water pump seals which is the backup to the normal filtered water supply check valves.

Test Requirement:

Quarterly full stroke.

Basis for Relief:

The only method for testing the valves in the backup seal water supply system involves putting unfiltered river water into the pump seals. In order to minimize the degradation to the pump seals that this causes and to reduce maintenance, relief is requested from quarterly and cold shutdown stroke testing.

Alternate Test:

Full-stroke exercised open during refueling outages per 1OST-30.2, 3 and 6.

RELIEF REQUEST 36**Valve No.:**

SOV-1EE-101
SOV-1EE-102
SOV-1EE-103
SOV-1EE-104

Category B**Class** 3**Function:**

Diesel Generator Air Start SOVs

Test Requirement:

Quarterly full stroke and time.

Basis for Relief:

These valves are quick acting and do not have position indication. The operation of these valves will be monitored by each individual diesel generator's start failure alarm circuit. Malfunctions which will cause the annunciator panel START FAILURE light to come on and the alarm bell to ring are:

1. Engine fails to crank above 40 RPM within 3 seconds after a start signal is received or
2. Engine cranks above 40 RPM within 3 seconds, but fails to exceed 2000 RPM within 4 seconds after a start signal is received.

Individual valves will be tested monthly on an alternating frequency by using a different set of air starting motors each month to crank the engine. This will ensure each bank is capable of starting the diesel generator in the required time and that the air start SOVs are not degrading.

Alternate Test:

Stroked and indirectly timed by the START FAILURE annunciator on an alternating frequency in conjunction with monthly diesel generator IOSTs 36.1 & 2 to ensure compliance with the ASME XI requirement for stroke testing on a quarterly frequency.

RELIEF REQUEST 37**Valve No.:**

TV-1VS-101A
TV-1VS-101B
TV-1VS-101C
TV-1VS-101D
TV-1VS-101E

Category B**Class** 3**Function:**

Control room emergency air bottle outlet trip isolation valves.

Test Requirement:

Quarterly full stroke and time.

Basis for Relief:

These valve are shut at power but are required to open to fulfill their safety function. Quarterly full or part stroke exercising is not possible without risking violating technical specification bottle pressure and time requirements. In addition, the air bottles are now shared between Unit 1 and 2, making testing during cold shutdowns impracticable. Also, these valves do not have control switches and lack valve position indicating lights in the control room.

Alternate Test:

Full-stroke exercised but not timed every 18 months per 3BVT 1.44.1.

RELIEF REQUEST 38**Valve No.:**

1VS-D-5-3A

1VS-D-5-3B

Category A**Class** 2**Function:**

Containment purge exhaust fan containment isolation dampers.

Test Requirement:

IWV-3426 and 3427(a) require Owner specified maximum permissible leakage rates for specific valves as a function of valve size and type and provide the corrective action to be followed when these limits are exceeded.

Basis for Relief:

As shown on the attached figure for Penetration #90, the configuration of this containment penetration (i.e., a single test connection located between two containment isolation dampers in series) is such that individual leakage rates for each specific damper cannot be determined using the test method of 10CFR50, Appendix J. In this case, assigning maximum permissible leakage rates for each damper would not be practical.

Alternate Test:

Assign a maximum permissible leakage rate for the entire penetration to then be used as the criteria for initiating corrective action in accordance with IWV-3427(a).

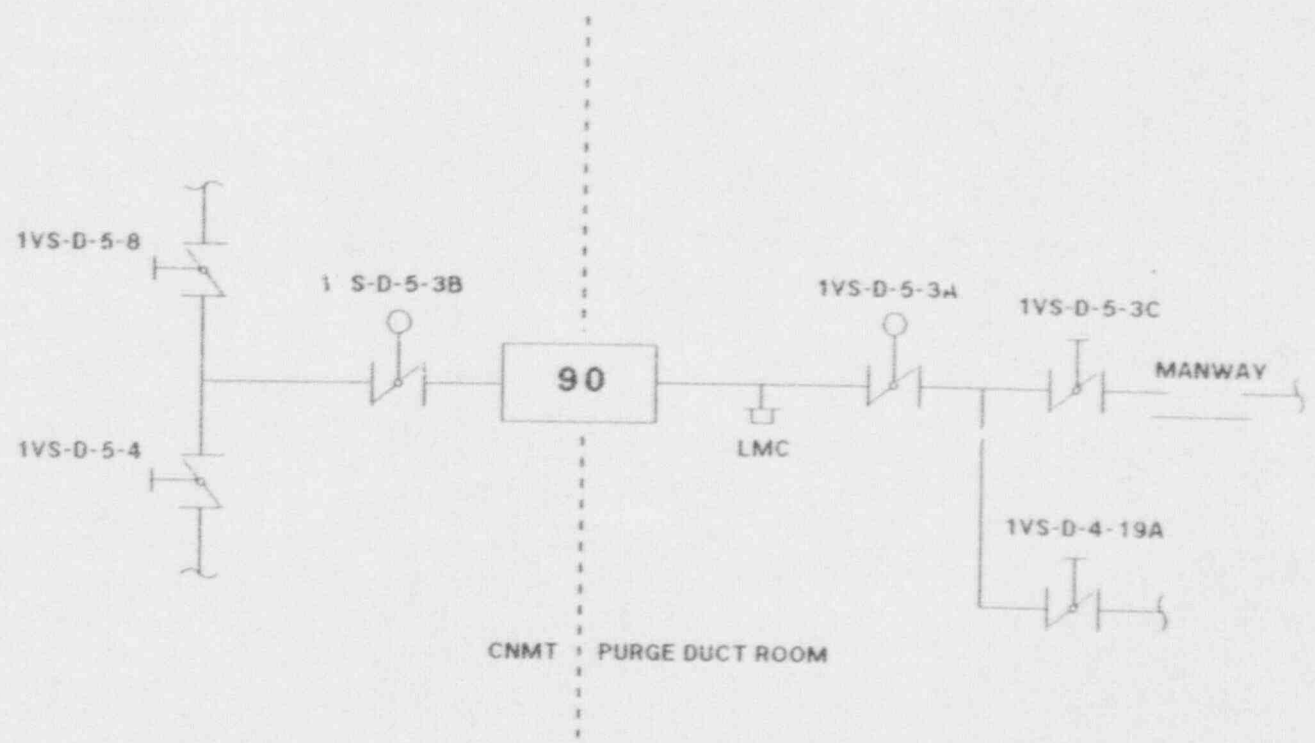

PENETRATION # 90

RELIEF REQUEST 39**Valve No.:**

1VS-D-5-5A

1VS-D-5-5B

1VS-D-5-6

Category A**Class** 2**Function:**

Containment purge supply fan containment isolation dampers.

Test Requirement:

IWV-3426 and 3427(a) require Owner specified maximum permissible leakage rates for specific valves as a function of valve size and type and provide the corrective action to be followed when these limits are exceeded.

Basis for Relief:

As shown on the attached figure for Penetration #91, the configuration of this containment penetration (i.e., a single test connection located between three penetration isolation dampers) is such that individual leakage rates for each specific damper cannot be determined using the test method of 10CFR50, Appendix J. In this case, assigning maximum permissible leakage rates for each damper would not be practical.

Alternate Test:

Assign a maximum permissible leakage rate for the entire penetration to then be used as the criteria for initiating corrective action in accordance with IWV-3427(a).

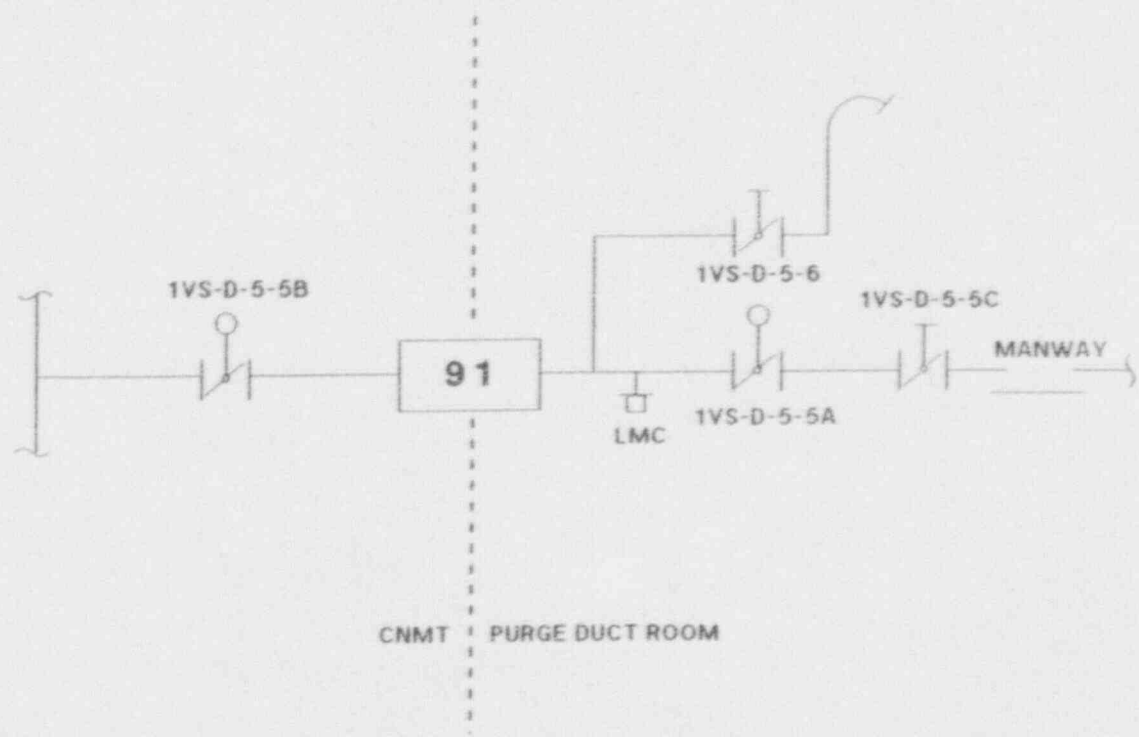

PENETRATION # 91

RELIEF REQUEST 40**Valve No.:**

TV-1CV-150A

TV-1CV-150B

1HY-101

1HY-103

Category A**Class** 2**Function:**

Containment Vacuum Pump 1A and Hydrogen Recombiner 1A suction containment isolation valves.

Test Requirement:

I WV-3426 and 3427(a) require Owner specified maximum permissible leakage rates for specific valves as a function of valve size and type and provide the corrective action to be followed when these limits are exceeded.

Basis for Relief:

As shown on the attached figure for Penetration #93, the configuration of this containment penetration (i.e., two in-series isolation valves in each of two parallel branch lines) is such that individual leakage rates for each specific damper cannot be determined using the test method of 10CFR50, Appendix J. In this case, assigning maximum permissible leakage rates for each damper would not be practical.

Alternate Test:

Assign a maximum permissible leakage rate for the two valve combinations of [TV-1CV-150B & 1HY-101] and [TV-1CV-150A & 1HY-103] to then be used as the criteria for initiating corrective action in accordance with I WV-3427(a).

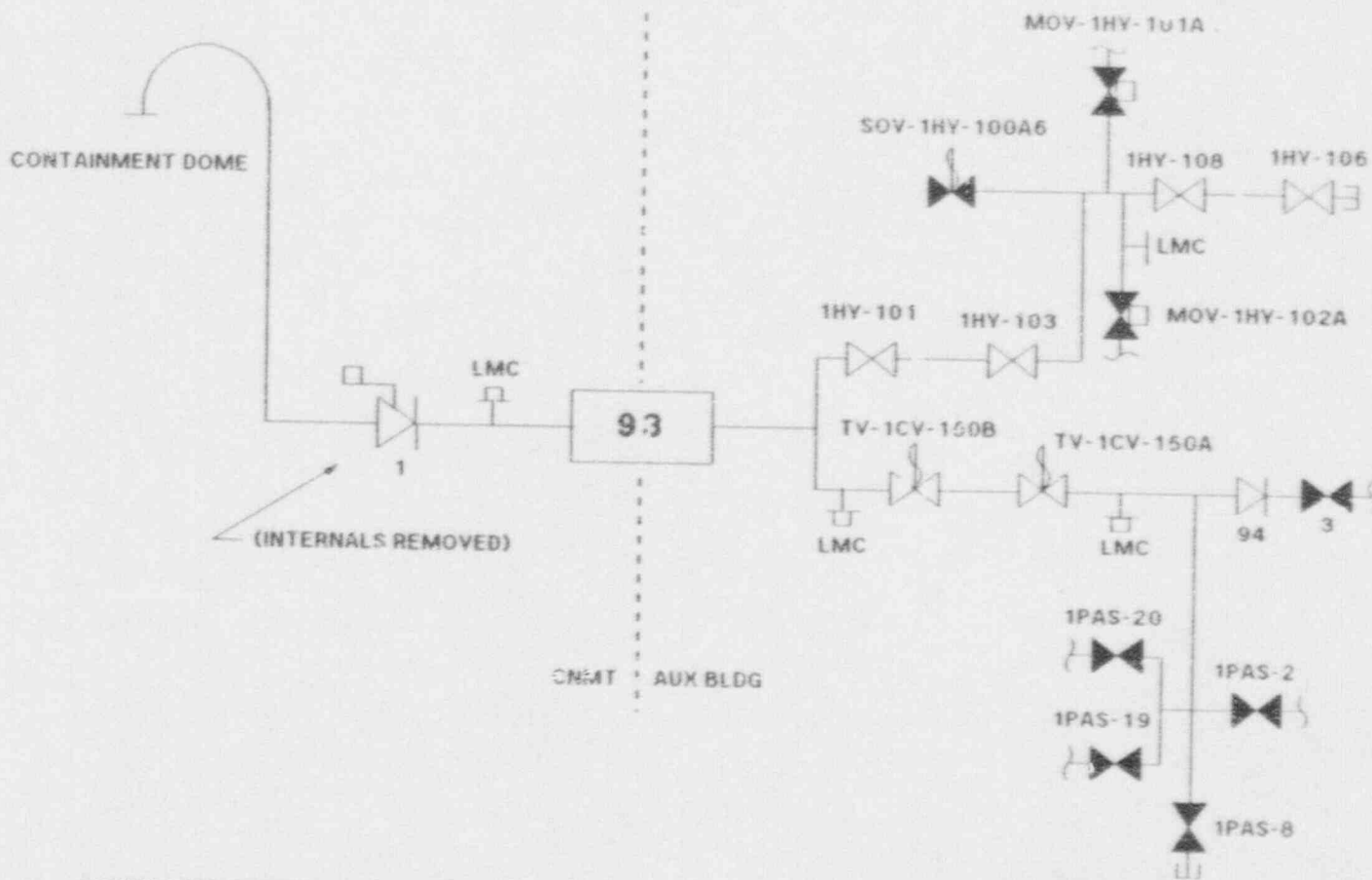

SYSTEM DESIGNATION
(1CV)

PENETRATION # 93

RELIEF REQUEST 41**Valve No.:**

TV-1CV-150C

TV-1CV-150D

1HY-102

1HY-104

Category A**Class** 2**Function:**Containment Vacuum Pump 1B and Hydrogen Recombiner
1B suction containment isolation valves.**Test Requirement:**IWV-3426 and 3427(a) require Owner specified maximum
permissible leakage rates for specific valves as a function of
valve size and type and provide the corrective action to be
followed when these limits are exceeded.**Basis for Relief:**As shown on the attached figure for Penetration #92, the
configuration of this containment penetration (i.e., two
in-series isolation valves in each of two parallel branch lines)
is such that individual leakage rates for each specific damper
cannot be determined using the test method of 10CFR50,
Appendix J. In this case, assigning maximum permissible
leakage rates for each damper would not be practical.**Alternate Test:**Assign a maximum permissible leakage rate for the two
valve combinations of [TV-1CV-150C & 1HY-102] and
[TV-1CV-150D & 1HY-104] to then be used as the criteria for
initiating corrective action in accordance with IWV-3427(a).

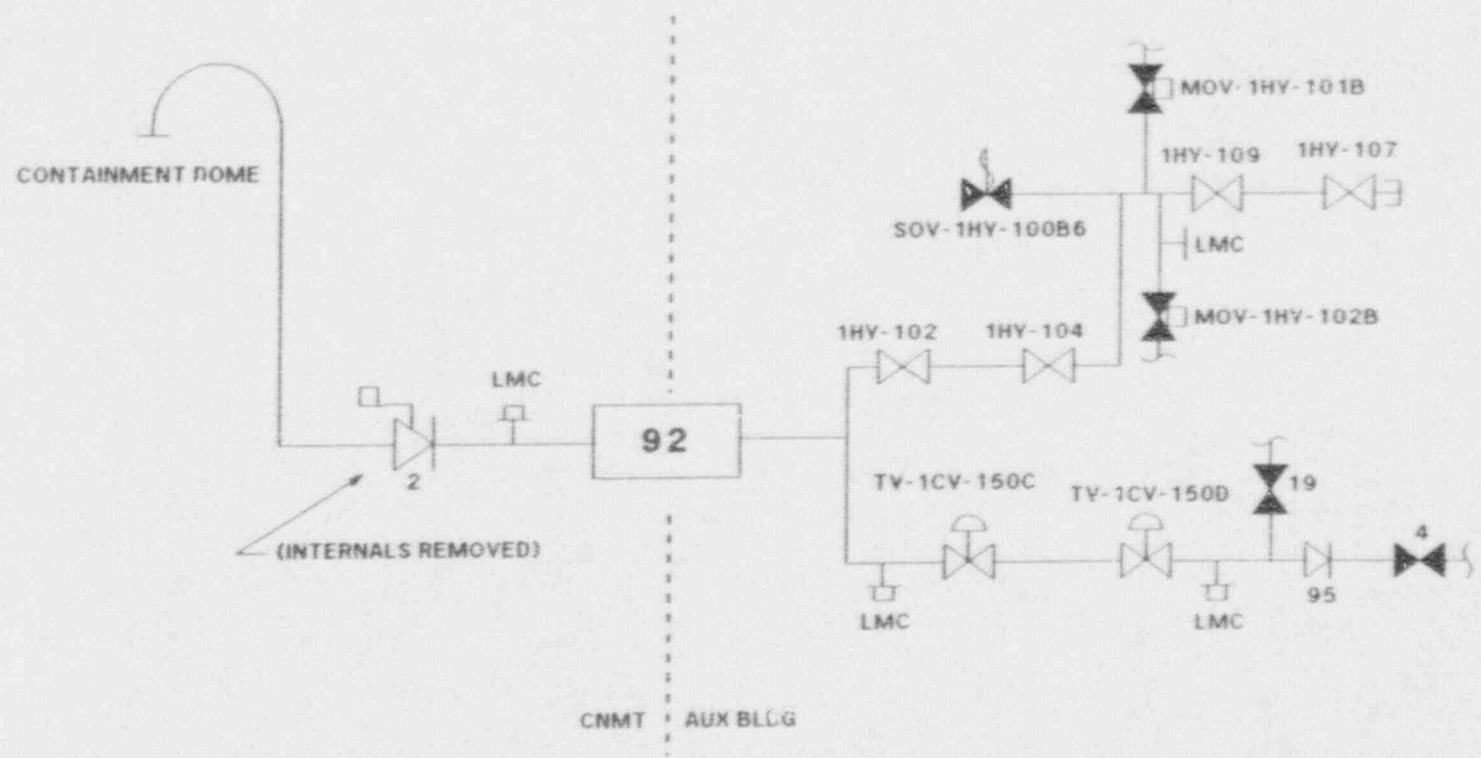

PENETRATION # 92

SYSTEM DESIGNATION
 (1CV)

RELIEF REQUEST 42**Valve No.:**

1VS-183

1VS-184

Category A**Class** 2**Function:**

Containment Isolation (Emergency Air Lock)

Test Requirement:

Leak tested per IWV-3420. In addition IWV-3426 and 3427(a) require Owner specified maximum permissible leakage rates for specific valves as a function of valve size and type and provide the corrective action to be followed when these limits are exceeded.

Basis for Relief:

These containment isolation valves are leak tested in accordance with 10CFR50, Appendix J, Type B. Since the acceptance criteria for Appendix J, Type B testing is more limiting than ASME Section XI, additional leak testing in accordance with ASME Section XI would be redundant. In addition, as shown on the attached figure for the Emergency Air Lock, the configuration of this containment penetration (i.e., a single test connection located in the emergency airlock between two airlock equalization valves) is such that individual leakage rates for each specific valve cannot be determined using the test method of 10CFR50, Appendix J. In this case, assigning maximum permissible leakage rates for each valve would not be practical.

Alternate Test:

Leak test semi-annually in accordance with Technical Specification 4.6.3.1.b.1, 10CFR50, Appendix J and IWV-3426 per 1BVT 1.47.10. In addition, assign a maximum permissible leakage rate for the entire airlock to then be used as the criteria for initiating corrective action in accordance with IWV-3427(a).

RELIEF REQUEST 42

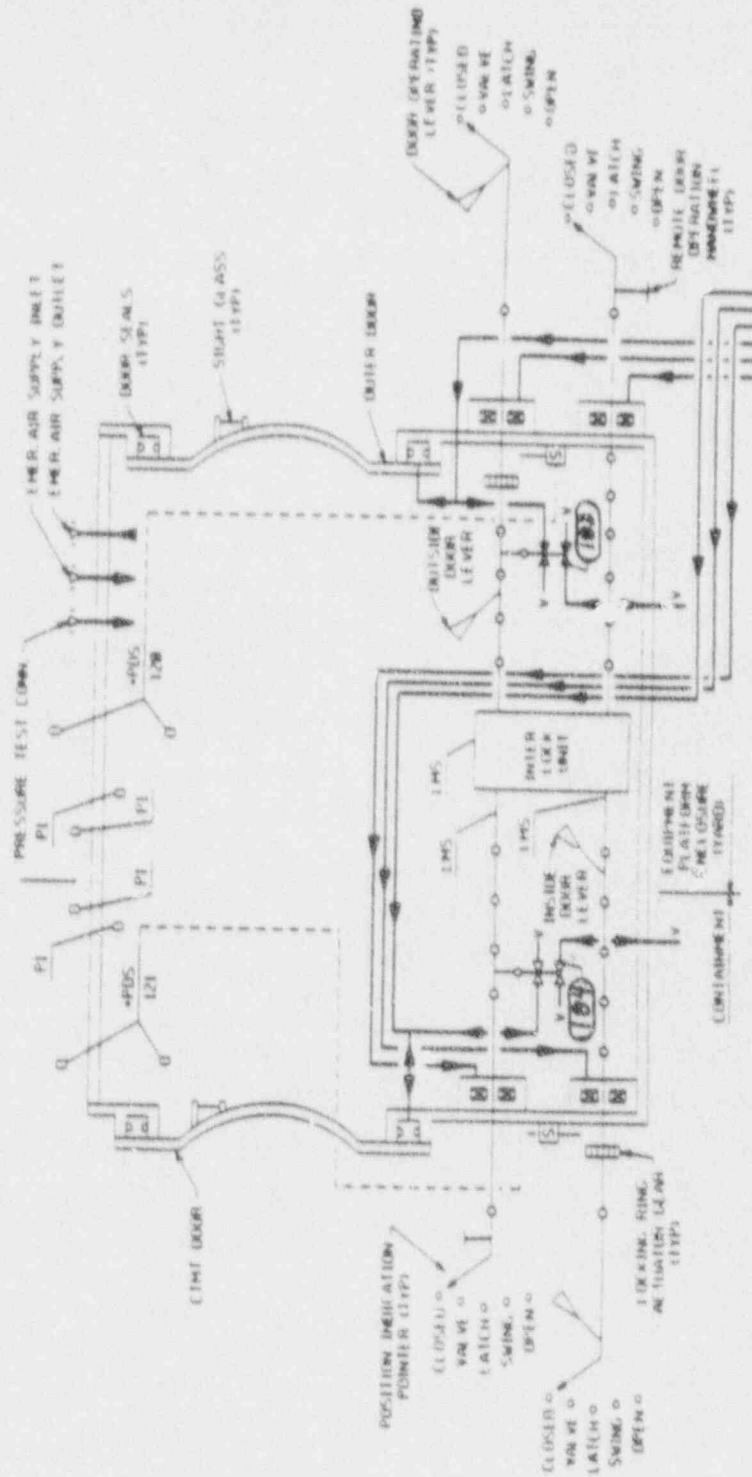

EMERGENCY AIR LOCK