



Clinton Power Station
Individual Plant Examination
Final Report
September 1992

<u>Section</u>	<u>Title</u>	<u>Page</u>
1.	Executive Summary.....	i-1
1.1	Background and Objectives.....	1-1
1.2	Plant Familiarization.....	1-4
1.3	Overall Methodology.....	1-5
1.4	Summary of Major Findings.....	1-7
1.4.1	Clinton Specific Level 1 Analysis.....	1-7
1.4.2	Clinton Specific Level 2 Analysis.....	1-15
1.4.3	Containment Performance Findings.....	1-16
1.4.4	Consistency With Other PRA's.....	1-19
2.	Examination Description.....	2-1
2.1	Introduction.....	2-1
2.2	Conformance with Generic Letter and Supporting Material.....	2-1
2.3	General Methodology.....	3-2
2.3.1	Initiating Events.....	2-2
2.3.2	Event Trees.....	2-3
2.3.3	Fault Trees.....	2-3
2.3.4	Data Analysis.....	2-5
2.3.5	Quantification.....	2-6
2.3.6	Containment Analysis.....	2-6
2.3.7	Documentation.....	2-8
2.4	Information Assembly.....	2-9
2.4.1	Plant Layout.....	2-9
2.4.2	IPE/PRA Review.....	2-10
2.4.3	Reference Documentation	2-11
2.4.4	Walkdowns.....	2-14

<u>Section</u>	<u>Title</u>	<u>Page</u>
3.	Front-End Analysis.....	3-1
3.1	Accident Sequence Delineation.....	3-1
3.1.1	Initiating Events.....	3-1
3.1.2	Front-Line Event Trees.....	3-15
3.1.3	Special Event Trees.....	3-33
3.1.4	Support System Event Trees.....	3-34
3.1.5	Sequence Grouping and Back-End Interfaces.....	3-34
3.2	System Analysis.....	3-63
3.2.1	System Descriptions.....	3-63
3.2.2	Fault Tree Methodology.....	3-91
3.2.3	Dependency Matrices.....	3-94
3.3	Sequence Quantification.....	3-162
3.3.1	List of Generic Data.....	3-164
3.3.2	Plant-Specific Data and Analysis.....	3-165
3.3.3	Human Failure Data (Generic and Plant-Specific).....	3-167
3.3.4	Common-Cause Failure Data.....	3-183
3.3.5	Quantification of Unavailability of Systems and Functions.....	3-185
3.3.6	Generation of Support System States and Quantification of Their Probabilities.....	3-187
3.3.7	Quantification of Sequence Frequencies.....	3-187
3.3.8	Internal Flooding Analysis.....	3-182
3.4	Results and Screening Process.....	3-212
3.4.1	Application of Generic Letter Screening Criteria.....	3-213
3.4.2	Vulnerability Screening.....	3-228

<u>Section</u>	<u>Title</u>	<u>Page</u>
	3.4.3 Decay Heat Removal Evaluation.....	3-229
	3.4.4 Unresolved Safety Issue and Generic Safety Issue Screening.....	3-232
4.	Back-End Analysis.....	4-1
4.1	Plant Data and Plant Description.....	4-3
4.1.1	Clinton Power Station Containment.....	4-3
4.1.2	Containment Systems.....	4-5
4.1.3	Systems Credited After Containment Failure.....	4-11
4.2	Plant Models and Methods for Physical Processes.....	4-18
4.2.1	Plant Models.....	4-18
4.2.2	General Assumptions.....	4-18
4.3	Bins and Plant Damage States.....	4-22
4.3.1	Methodology.....	4-22
4.3.2	Front-to-Back End Interfaces.....	4-23
4.3.3	Plant Damage States.....	4-24
4.3.4	Release Mode.....	4-25
4.3.5	Assessment of Source Term Importance.....	4-26
4.4	Containment Failure Characterization.....	4-33
4.4.1	Direct Containment Bypass.....	4-33
4.4.2	Vessel Blowdown.....	4-34
4.4.3	Steam Explosions.....	4-35
4.4.4	Penetration Thermal Attack.....	4-39
4.4.5	Containment Isolation.....	4-40
4.4.6	Direct Containment Heating.....	4-41
4.4.7	Molten Core-Concrete Interaction.....	4-44

<u>Section</u>	<u>Title</u>	<u>Page</u>
	4.4.8 Hydrogen Combustion.....	4-50
	4.4.9 Containment Overpressurization.....	4-51
4.5	Containment Event Trees.....	4-56
	4.5.1 Introduction.....	4-56
	4.5.2 CET Headings.....	4-57
	4.5.3 Containment Event Trees.....	4-60
	4.5.4 Assumptions.....	4-60
	4.5.5 Plant Damage States.....	4-60
	4.5.6 Release Modes.....	4-61
	4.5.7 Source Terms.....	4-61
4.6	Accident Progression and CET Quantification.....	4-68
	4.6.1 Accident Progression.....	4-68
	4.6.2 Accident Sequence Recovery Actions, Post Core Damage.....	4-71
	4.6.3 CET Quantification.....	4-76
4.7	Radionuclide Release Characterization.....	4-110
	4.7.1 Introduction.....	4-110
5.	Utility Participation and Project Reviews.....	5-1
	5.1 IPE Program Organization.....	5-1
	5.2 Composition of Project Review Teams.....	5-3
	5.2.1 System Engineer Review.....	5-4
	5.2.2 IPE Independent Review Team (IIRT).....	5-5
	5.2.3 Senior Management Review Team..... (SMRT)	5-6
	5.2.4 Consultant Involvement.....	5-7
	5.2.5 Engineering Assurance Review.....	5-8
	5.3 Areas of Review and Major Comments.....	5-8
	5.4 Resolution of Comments.....	5-8

<u>Section</u>	<u>Title</u>	<u>Page</u>
6.	Plant Improvements and Unique Safety Features.....	6-1
6.1	Introduction.....	6-1
6.2	Clinton Unique Safety Features.....	6-2
6.2.1	Equipment Independence.....	6-2
6.2.2	Feedwater Delivery System.....	6-3
6.2.3	Containment Design.....	6-4
6.3	Evaluation of Important Features Affecting Core Damage Risk.....	6-4
6.3.1	Loss of Off-Site Power.....	6-5
6.3.2	High Pressure Core Spray Failures.....	6-6
6.3.3	Reactor Core Isolation Cooling Failures.....	6-7
6.3.4	Depressurization Failures.....	6-8
6.3.5	Transient Initiators.....	6-10
6.3.6	Failures of the Fire Protection System as a Core Cooling System.....	6-11
6.3.7	Power Recovery Failures Under LOOP Conditions.....	6-14
6.3.8	Shutdown Service Water Starting Failure.....	6-15
6.4	Evaluation of Important Features Affecting Risk of Radioactivity Release From The Containment.....	6-17
6.4.1	Loss of Off-Site Power.....	6-17
6.4.2	Recovery of AC Power.....	6-18
6.4.3	Failure to Isolate the Containment Under Station Blackout Conditions.....	6-19
6.4.4	High Pressure Core Spray and Reactor Core Isolation Cooling Failures.....	6-20
6.4.5	SCRAM Hardware Failures.....	6-20

<u>Sect.on</u>	<u>Title</u>	<u>Page</u>
6.5	Additional Risk Evaluations.....	6-22
6.5.1	Preventive Maintenance Outage Time....	6-22
6.5.2	Adequacy of Safety Related DC Power Supplies.....	6-23
6.5.3	Hydrogen Control Measures and Effects of Hydrogen Burns on Safety Equipment.....	6-23
6.5.4	Containment Improvements.....	6-24
6.6	Model Improvements.....	6-25
6.6.1	Diesel Recovery Failures.....	6-25
6.6.2	Manual Initiation of Suppression Pool Cooling.....	6-26
6.6.3	Other Improvements.....	6-26
7.	Summary and Conclusions.....	7-1

<u>Figure</u>	<u>Title</u>	<u>Page</u>
1.4-1	Core Damage Frequency by Initiator Category.....	1-11
1.4-2	Transient Core Damage Frequency by Specific Initiator	1-12
1.4-3	Core Damage Frequency by Accident Class.....	1-13
1.4-4	Containment Failure Fraction.....	1-17
1.4-5	Containment Failure	1-18
3.1-1	Transient Without Isolation Event Tree.....	3-46
3.1-2	Loss of Feedwater Event Tree.....	3-47
3.1-3	Loss of Non-Safety DC Bus Event Tree.....	3-48
3.1-4	Transient With Isolation Event Tree.....	3-49
3.1-5	Loss of Instrument Air Event Tree.....	3-50
3.1-6	Loss of Service Water Event Tree.....	3-51
3.1-7	Loss of Offsite Power Event Tree.....	3-52
3.1-8	Station Blackout Event Tree.....	3-53
3.1-9	Small Break LOCA Event Tree.....	3-54
3.1-10	Medium Break LOCA Event Tree.....	3-55
3.1-11	Large Break LOCA Event Tree.....	3-56
3.1-12	Interfacing System LOCA Event Tree.....	3-57
3.1-13	Inadvertent Open Relief Valve Event Tree.....	3-58
3.1-14	Anticipated Transient Without Scram Event Tree -Sheet A.....	3-59
3.1-15	Anticipated Transient Without Scram Event Tree -Sheet B.....	3-60
3.1-16	Anticipated Transient Without Scram Event Tree -Sheet C.....	3-61
3.1-17	Anticipated Transient Without Scram Event Tree -Sheet D.....	3-62
3.2-1	Simplified Scram Logic.....	3-106
3.2-2	Division 1 Scram Seal-In/Reset Logic.....	3-107

<u>Figure</u>	<u>Title</u>	<u>Page</u>
3.2-3	Scram Discharge Volume.....	3-108
3.2-4	ARI/RR Pump Trip Logic.....	3-109
3.2-5	Division 1 Initiation Logic - Sheet 1.....	3-110
3.2-6	Division 1 Initiation Logic - Sheet 2.....	3-111
3.2-7	Division 1 Initiation Logic - Sheet 3.....	3-112
3.2-8	Division 2 Initiation Logic - Sheet 1.....	3-113
3.2-9	Division 2 Initiation Logic - Sheet 2.....	3-114
3.2-10	Division 2 Initiation Logic - Sheet 3.....	3-115
3.2-11	Divisions 3 and 4 Initiation Logic.....	3-116
3.2-12	Reactor Core Isolation Cooling Initiation Logic..	3-117
3.2-13	Condensate System.....	3-118
3.2-14	Condensate Polisher System.....	3-119
3.2-15	Condensate Booster System.....	3-120
3.2-16	Feedwater System.....	3-121
3.2-17	Main Steam System.....	3-122
3.2-18	Condenser Air Removal System.....	3-123
3.2-19	Off Gas System.....	3-124
3.2-20	Gland Seal Steam System - Sheet 1.....	3-125
3.2-21	Gland Seal Steam System - Sheet 2.....	3-126
3.2-22	Circulating Water System.....	3-127
3.2-23	High Pressure Core Spray System.....	3-128
3.2-24	Reactor Core Isolation Cooling System.....	3-129
3.2-25	Low Pressure Core Spray System.....	3-130
3.2-26	Residual Heat Removal System.....	3-131
3.2-27	Engineered Safety Feature Actuation Logic.....	3-132
3.2-28	ADS Actuation Logic.....	3-133

<u>Figure</u>	<u>Title</u>	<u>Page</u>
3.2-29	Standby Liquid Control System.....	3-134
3.2-30	Control Rod Drive System.....	3-135
3.2-31	Containment Venting to Spent Fuel Storage Pool...3-136	
3.2-32	Containment Venting to Spent Fuel Storage Pool...3-137	
3.2-33	Auxiliary Power System - Sheet 1.....	3-138
3.2-34	Auxiliary Power System - Sheet 2.....	3-139
3.2-35	Auxiliary Power System - Sheet 3.....	3-140
3.2-36	Auxiliary Power System - Sheet 4.....	3-141
3.2-37	Division 1 DC Distribution System.....	3-142
3.2-38	Division 2 DC Distribution System.....	3-143
3.2-39	Division 3 DC Distribution System.....	3-144
3.2-40	Division 4 DC Distribution System.....	3-145
3.2-41	Balance of Plant DC Distribution System -..... Sheet 1	3-146
3.2-42	Balance of Plant DC Distribution System -..... Sheet 2	3-147
3.2-43	Division 1 Shutdown Service Water System -..... Sheet 1	3-148
3.2-44	Division 1 Shutdown Service Water System -..... Sheet 2	3-149
3.2-45	Division 2 Shutdown Service Water System -..... Sheet 1	3-150
3.2-46	Division 2 Shutdown Service Water System -..... Sheet 2	3-151
3.2-47	Division 3 Shutdown Service Water System.....	3-152
3.2-48	Plant Service Water System - Sheet 1.....	3-153
3.2-49	Plant Service Water System - Sheet 2.....	3-154
3.2-50	Plant Service Water System - Sheet 3.....	3-155
3.2-51	Plant Service Water System - Sheet 4.....	3-156
3.2-52	Instrument Air/Service Air System.....	3-157

<u>Figure</u>	<u>Title</u>	<u>Page</u>
3.2-53	Component Cooling Water System.....	3-158
3.2-54	Turbine Building Closed Cooling Water System.....	3-159
3.2-55	Fire Protection System.....	3-160
3.2-56	Containment CCP Vent Pathway.....	3-161
4.1-1	Clinton Containment.....	4-14
4.1-2	SRV Discharge Locations.....	4-15
4.1-3	Typical SRV Quencher.....	4-16
4.1-4	Containment Combustible Gas Control Flowpath.....	4-17
4.3-1	Containment Release Mode Example.....	4-32
4.4-1	Cumulative Probability Distribution Function for Failure of the CPS Containment.....	4-55
4.5-1	Class IA CET.....	4-62
4.5-2	Class IB CET.....	4-63
4.5-3	Class ID CET.....	4-64
4.5-4	Class IIIB CET.....	4-65
4.5-5	Class IIIC CET.....	4-66
4.5-6	Class IV CET.....	4-67
4.6-1	Typical High Pressure RPV Failure Sequence.....	4-93
4.6-2	Typical High Pressure RPV Failure Sequence.....	4-94
4.6-3	Typical High Pressure RPV Failure Sequence.....	4-95
4.6-4	Typical Station Black Out Sequence.....	4-96
4.6-5	Typical Station Black Out Sequence.....	4-97
4.6-6	Typical Station Black Out Sequence.....	4-98
4.6-7	Typical Low Pressure RPV Failure Sequence.....	4-99
4.6-8	Typical Low Pressure RPV Failure Sequence.....	4-100
4.6-9	Typical Low Pressure RPV Failure Sequence.....	4-101
4.6-10	Typical High Pressure RPV Failure LOCA Sequence...4-102	
4.6-11	Typical High Pressure RPV Failure LOCA Sequence...4-103	

4.6-12	Typical High Pressure RPV Failure LOCA Sequence...	4-104
4.6-13	Typical Low Pressure LOCA Sequence.....	4-105
4.6-14	Typical Low Pressure LOCA Sequence.....	4-106
4.6-15	Typical Low Pressure LOCA Sequence.....	4-107
4.6-16	Typical ATWS Sequence.....	4-108
4.6-17	Typical ATWS Sequence.....	4-109
4.7-1	Containment Failure Graphs.....	4-115
5.1-1	Organizational Chart of IPE Team.....	5-9
5.2-1	Organizational Chart of SMRT.....	5-10

<u>Table</u>	<u>Title</u>	<u>Page</u>
1.4-1	Core Damage Frequency by Initiator.....	1-9
1.4-2	Core Damage Frequency by Initiator Category.....	1-10
1.4-3	Core Damage Frequency by Accident Class.....	1-10
1.4-4	Dominant Accident Sequences.....	1-14
2.4-1	Reference Documentation.....	2-12
3.1-1	Initiating Event Grouping Guidelines.....	3-36
3.1-2	CPS Initiating Events with Initiating Event Frequencies and Event Tree Designators.....	3-37
3.1-3	Clinton IPE Interfacing Systems LOCA Frequencies.....	3-39
3.1-4	Comparison of Industry and Clinton Plant Specific Transient Frequency Data.....	3-40
3.1-5	CPS Front-Line and Critical Support Systems.....	3-41
3.1.6	Accident Sequence Classes.....	3-42
3.1.7	Accident Sequence Subclasses.....	3-44
3.2-1	CPS IPE Fault Trees	3-95
3.2-2	Components/Failure Modes/Transfers Included in the PRA Fault Trees.....	3-96
3.2-3	Initiating Event to Front-line System Dependency Matrix.....	3-97
3.2-4	Front-Line System to Frontline System Dependency Matrix.....	3-100
3.2-5	Front-Line to Support System Dependency Matrix.....	3-103
3.3-1	Generic Component Failure Rate Data.....	3-192
3.3-2	Restoration and Calibration Errors	3-195
3.3-3	Post-Initiator Human Interactions	3-197
3.3-4	Sensitivity Analysis of Important Human Interactions.....	C-198
3.3-5	Results of Detailed Human Reliability Analysis...	3-199

<u>Table</u>	<u>Title</u>	<u>Page</u>
3.3-6	List of Major HRA Events Based Upon the CPS Sensitivity Analysis.....	3-200
3.3-7	Non-Recovery Probabilities for Significant Basic Events.....	3-201
3.3-8	Conditional Probabilities for Recovery of Off-Site Power.....	3-204
3.3-9	Time-Phased Recovery for Short Term Station Blackout Sequence TLU1U2.....	3-205
3.3-10	Time-Phased Recovery for Long Term Station Blackout Sequence TLU1L4DG1DG2.....	3-205
3.3-11	Common Cause Component Groups.....	3-206
3.3-12	Common Cause Failure Rate Estimates.....	3-207
3.3-13	Maintenance Unavailabilities Derived From Plant Data.....	3-209
3.3-14	Internal Flooding Event Data.....	3-211
3.4-1	Core Damage Frequency by Accident Class.....	3-233
3.4-2	Accident Sequences Contributing to Core Damage Frequency Which Meet the Screening Criteria.....	3-234
3.4-3	Internal Flooding Dominant Core Damage Sequences	3-235
4-1	Comparison of BWR-6 Containment Capacities.....	4-1
4.1-1	Principal Dimensions and Parameters for CPS Containment.....	4-13
4.3-1	Front-to-Back End Interface.....	4-27
4.3-2	Level 1 to Level 2 System Dependencies.....	4-28
4.3-3	Plant Damage State Codes.....	4-29
4.3-4	Release Modes.....	4-30
4.3-5	Level 2 Release Categories.....	4-31
4.4-1	Drywell and Containment Penetration Elastomers....	4-54
4.6-1	Time-Phased Recovery for Station Blackout Sequence TLU1U3.....	4-92
4.6-2	Time-Phased Recovery for Station Blackout Sequence TLU1L4DG1DG2.....	4-92

<u>Table</u>	<u>Title</u>	<u>Page</u>
4.7-1	Source Term Release Data.....	4-112
4.7-2	Containment Sequence Performance Summary.....	4-114
6-1	Basic Events With Highest Fussel-Vesely Importance Measures for Core Damage Cutsets.....	6-27
6-2	Basic Events With Highest Fussel-Vesely Importance Measures for Class 1B Core Damage Cutsets.....	6-28
6-3	Basic Events With Highest Fussel-Vesely Importance Measures for Class 1A Core Damage Cutsets.....	6-30
6-4	Basic Events With Highest Fussel-Vesely Importance Measures for Containment Failure Cutsets.....	6-31

ACRONYM	MEANING
AC	Alternating Current
ADS	Automatic Depressurization System
ARI	Alternate Rod Insertion
ARSAP	Advanced Reactor Severe Accident Program
ASEI	Accident Sequence Evaluation Program
ATWS	Anticipated Transient Without Scram
BOP	Balance of Plant (non-NSSS systems)
BWR	Boiling Water Reactor
BWROG	Boiling Water Reactor Owner's Group
CA	Condenser Vacuum System
CAFTA	Computer Aided Fault Tree Analysis
CB	Condensate Booster (system)
CCF	Common Cause Failure
CCI	Core-Concrete Interaction
CD	Condensate (system)
CDF	Core Damage Frequency
CET	Containment Event Tree
CM	Corrective Maintenance
CPS	Clinton Power Station
CRD	Control Rod Drive (system)
CS	Containment Spray (mode of RHR)
CSF	Critical Safety Function
CW	Circulating Water System
CY	Cycled Condensate (system)
DC	Direct Current (supply or system)
DCH	Direct Containment Heating
DDT	Deflagration to Detonation Transition
DG	Diesel Generator
ECCS	Emergency Core Cooling System(s)
EOP	Emergency Operating Procedure
EPG	Emergency Procedure Guidelines
EPRI	Electric Power Research Institute
ERAT	Emergency Reserve Auxiliary Transformer
ESW	Extremely Severe Weather (>125 mph)
ET	Event Tree
FP	Fire Protection (system)
FT	Fault Tree
FTR	Fail to Run
FTS	Fail to Start
F	Feedwater (system)
GE	General Electric Company
GESSAR	General Electric Standard Safety Analysis Report
GG	Grand Gulf (Nuclear Station)
GS	Main Turbine Generator System
GSI	Generic Safety Issue
HCOG	Hydrogen Control Owner's Group
HEP	Human Error Probability
HP	High Pressure Core Spray
HPCS	High Pressure Core Spray
HRA	Human Reliability Analysis
HVAC	Heating, Ventilation, and Air Conditioning

ACRONYM	MEANING
IA	Instrument Air
IDCOR	Industry Degraded Core Rulemaking Effort
IE	Initiating Event
IIRT	IPE Independent Review Team
IN	ECCS/RCIC/ARI/PI; Initiation Logic
IORV	Inadvertent Open Relief Valve
IPE	Individual Plant Examination
IPEEE	Individual Plant Examination for External Events
IPEM	Individual Plant Evaluation Methodology (by IDCOR,
ISLOCA	Interfacing System LOCA
IST	Independent Sub-Tree
LCO	Limiting Conditions for Operation (Technical Specifications)
LLOCA	Large LOCA
LLRT	Local Leak Rate Test
LOCA	Loss of Coolant Accident
LOOP	Loss of Offsite Power
LP	Low Pressure Core Spray
LPCI	Low Pressure Coolant Injection (Mode of RHR)
LPCS	Low Pressure Core Spray
LTSB	Long Term Station Blackout
MAAP	Modular Accident Analysis Program
MGL	Multiple Greek Letter Common Cause Probability Model
MLOCA	Medium LOCA
MOV	Motor-Operated Valve
MS	Main Steam (system)
MSCWL	Minimum Steam Cooling Water Level
MSIV	Main Steam Isolation Valve
MWth	Mega-Watts, Thermal
NB	Nuclear Boiler (system)
NPSH	Net Positive Suction Head
NSAC	Nuclear Safety Analysis Center
NSED	Nuclear Station Engineering Department
NSPS	Nuclear System Protection System
NSSS	Nuclear Steam Supply System
OG	Off Gas System
OS	Operational Schematic Drawings
OSP	Off-Site Power
PCS	Power Conversion System (BOP)
PDS	Plant Damage State
PM	Preventive Maintenance
PRA	Probabilistic Risk Assessment
PSF	Performance Shaping Factor(s)
PWR	Pressurized Water Reactor
RAT	Reserve Auxiliary Transformer
RCIC	Reactor Core Isolation Cooling System
RD	Control Rod Drive (system)
RFP	Recovery Failure Probability
RH	Residual Heat Removal (system)
RHR	Residual Heat Removal (system)
RI	Reactor Core Isolation Cooling System

ACRONYM	MEANING

RPS	Reactor Protection System
RPT	Recirculation Pump Trip
RPV	Reactor Pressure Vessel
RT	Reactor Water Cleanup System
RWCU	Reactor Water Cleanup System
S&L	Sargent & Lurdy (Plant Designer)
SA	Service Air
SBO	Station Black Out
SC	Standby Liquid Control (system)
SCRAM	Safety Control Rod Axe Man (Rapid Reactor Shut Down)
SE	System Engineer
SETS	Set Equation Transformation System
SJAE	Steam Jet Air Ejector
SLC	Standby Liquid Control (system)
SLOCA	Small LOCA
SMRT	Senior Management Review Team
SPC	Suppression Pool Cooling (mode of RHR)
SPMU	Suppression Pool Make-Up
SRO	Senior Reactor Operator
SRV	Main Steam Safety Relief Valve
SSPR	Safety System Performance Review
STA	Shift Technical Advisor
STSB	Short-Term Station Blackout
SX	Shutdown Service Water (system)
TBCCW	Turbine Building Closed Cooling Water
TOAF	Top of Active Fuel (Reactor Water Level)
UAT	Unit Auxiliary Transformer
UHC	Ultimate Hydrogen Concentration
USAR	Updated Safety Analysis Report
USI	Unresolved Safety Issue
WS	Plant Service Water

Accident Class Core damage bin for similar effects on containment systems and function, grouping of end states for level 1 event trees.

Accident Sequence A specific path through the event trees representing a unique combination of success or failure of the headings. The headings represent the systems functions necessary to mitigate the consequences of the accident.

Cutset A combination of failures which, if they all occur, will cause the undesirable outcome being evaluated to occur. For example, a core damage cutset is a combination of failures that can cause core damage.

Independent Sub-Tree Portions of a fault tree that may be repeated in different parts of a fault tree or on different trees but always in the same form. Identified as an entity by the quantification software and subsequently treated as a value for computational efficiency.

Plant Damage State Bin of combinations of core damage and containment conditions from the end state of containment event trees.

Release Mode Description of containment failure mode and fission product release pathway bins, such as scrubbed or not, early or late, etc.

1. EXECUTIVE SUMMARY

This document provides the results of the Individual Plant Examination (IPE) of internal accident initiating events performed for Illinois Power Company's (IP's) Clinton Power Station in response to the August 1985 NRC Policy Statement on issues related to severe accidents in NUREG-1070 and 10CFR50. A comprehensive and systematic plant analysis has been performed, employing the accepted principles of Level I and II Probabilistic Risk Assessment (PRA). The focus of this analysis was to identify the existence of any potential plant vulnerabilities to severe accidents and determine cost-effective safety improvements that could reduce or eliminate the impact of any such vulnerabilities. No such vulnerabilities were found. Instead the IPE has shown that the Clinton Power Station has been well designed and that its containment is robust. The safety improvements identified by the IPE involved only small reductions in the overall plant risk.

1.1 Background and Objectives

The Severe Accident Policy Statement issued in 1985 and implemented by the NRC staff in its Generic Letter 88-20 stated that on the basis of information available at that time, existing nuclear plants pose "no undue risk" to the health and safety of the public. Thus, the Commission found that its announced intention to conduct rulemaking was unwarranted at that time and rescinded the rulemaking notification. The commission's conclusion of "no undue risk" was based upon extensive actions taken as a result of the Three Mile Island action plan (NUREG-0737) and joint investigation by NRC and the industry-sponsored IDCOR¹ program of the large body of available information on

¹ (IDCOR - Industry Degraded Core Rulemaking Program began in 1981 and concluded in 1988. It worked in cooperation with the NRC to resolve the issues of Nuclear Plant Safety with regard to severe accidents)

severe accidents. The information evaluated included NRC and industry-sponsored research, published PRAs and operating experience. The investigation was conducted on four representative nuclear plants by IDCOR and six by NRC. On the basis of the results of these investigations, the generic conclusion of "no undue risk" was developed.

Although the Severe Accident Policy rescinded rulemaking, the Commission noted that the NRC staff, while performing PRAs on certain plants, had found instances of relatively plant-unique vulnerabilities that were correctable at low cost. The Commission concluded that these systematic studies should be done at other plants to determine whether plant-unique vulnerabilities existed and to identify cost-effective means to eliminate or mitigate them.

In November 1988, the NRC staff issued Generic Letter 88-20 to formally request that each utility perform a systematic plant examination under 10CFR50.54(f) to satisfy the intent of the policy. The Generic Letter requested the search for vulnerabilities, the identification of potential improvements, and the implementation of improvements that the utility believes to be appropriate. It also requested that each utility develop an overall appreciation for Severe Accident Behavior.

In August of 1989, the NRC issued the specific guidance for utility IPE performance and submittals in a supplement to the Generic Letter (NUREG-1335). The CPS IPE effort was begun in 1989 and the first phase, the analysis of internally initiated accident events, has been completed.

IP's Clinton Power Station (CPS) IPE was performed to develop an improved understanding of the plant's response to potential accident conditions by CPS personnel and to identify any significant vulnerabilities to severe accidents that may have been unknowingly included in the Clinton design. The specific

objectives of the IPE are summarized below. Each of these objectives is addressed by the report sections indicated in parentheses.

- Identify any dominant accident sequence that occurs with a frequency significantly higher than similar sequences at other plants which may therefore identify potential plant weaknesses (Section 1.4).
- Identify the potential accident sequences that contribute to the overall core damage frequency (Section 1.4).

Identify any instances of unusually poor containment performance for these dominant accident sequences (Section 1.4).

- Identify any cost-effective modifications to the plant design, operating procedures, training or maintenance practices that would reduce the likelihood of any accident sequence identified to be highly significant (Sections 6.3 and 6.4).
- Maximize participation in the evaluation process by CPS personnel and communicate the results of the IPE to departments and personnel that can use the information. Ensure that the implications of the IPE findings are understood by CPS management and personnel (Section 5.1).
- Establish a realistic estimate of the frequency of a core damage event (Section 3.4).
- Determine the timing and nature of any radionuclide releases to the environment that might be associated with the identified dominant accident sequences (Section 4.6).

- Develop risk-based tools and documentation to ensure the IPE can be maintained and understood by IPE personnel and to support resolution of future operational, safety, or regulatory issues for CPS.

1.2 Plant Familiarization

Illinois Power assembled an IPE team from among the plant operations and engineering staff. This team brought to the IPE project an extensive background in CPS design, systems, operating procedures, and technical specifications. Plant information was assembled from a variety of sources such as piping and electrical drawings, operating and emergency procedures, vendor manuals, and system descriptions. This information was analyzed for applicability and summarized in the IPE system notebooks. Plant walkdowns were conducted which provided additional familiarization with system layouts, conditions under which the systems must operate, and the physical arrangement of support systems and the opportunity to verify the overall accuracy of plant system information.

The IPE team maintained its integration in the CPS organization through continually participating in ongoing activities such as requalification training and proficiency watches. This contact with other CPS organizations allowed maintenance of a thorough familiarization with plant status, planned design changes, plant history, and plant problems throughout the performance of the IPE.

The IPE in-house review team is also composed of knowledgeable plant personnel who are intimately familiar with and active in all aspects of the plant design and operation.

The individuals and organizations composing the CPS IPE team and review teams are discussed further in Sections 5.1 and 5.2.

Detailed discussion of information assembly is provided in Section 2.4.

The composition of the IPE and in-house review teams allowed continuous access to on-shift operating crews, the plant engineering staff and to most plant areas. This access resulted in the application of the PRA to situations in which plant modifications have been contemplated. The usefulness of the CPS PRA has thus been demonstrated, and it is intended to be a living document used to support future plant operations.

1.3 Overall Methodology

The IPE program for the Clinton Power Station is based on level 1 and level 2 PRA methods described in the following NUREGS.

- NUREG/CR-2300, "PRA Procedures Guide"
- NUREG/CR-2815, "Probabilistic Safety Analysis Procedures Guide", and
- NUREG-1335, "Individual Plant Examination Submittal Guidance".

The CPS level 1 study started by determining initiating events, which are occurrences that can disrupt normal plant operation and result in a plant trip. A logic diagram (event tree) was constructed for each initiating event using nodes (branches) to depict success or failure of various systems or actions used to mitigate the unwanted effects of the initiating event.

Individual system fault-tree models were developed and then linked to properly account for system dependencies due to initiating events. The CPS level 1 model is based on a large fault tree and small event tree approach.

Single component failure probabilities were included as well as common cause failure data. The "Multiple Greek Letter" (MGL) method was used to model common cause failure.

Human error events were modeled in the fault trees as occurring prior to or after an initiating event. Screening values were used during the initial quantification to determine which human errors were significant. The human errors determined to be important were then evaluated in detail with the methodology described in NUREG/CR-4772, "Accident Sequence Evaluation Program (ASEP)".

Plant specific data were collected and used to calculate system unavailabilities and to support success criteria. Industry data were used for situations in which insufficient CPS data existed.

Containment Event Trees (CETs) were developed to characterize the containment response to severe accidents for the level 2 or "back-end" analysis. Certain severe accident phenomena were examined in detail, using past industry or CPS experiences, analytical work and CPS-specific parameters. Phenomenology evaluation summaries were developed for these phenomena to describe their applicability to Clinton and, if necessary, incorporation into the appropriate CET headings.

The level 1 and level 2 portions of the IPE were integrated by using the same analysts to perform both evaluations and continuing the sequence equations from the level 1 results through the sequences in the CETs. This assured continuity, consistency, and accuracy of the overall project.

A variety of software was used during the course of the IPE study. The Electric Power Research Institute's (EPRI's) Computer Aided Fault Tree Analysis (CAFTA) program was used for development and linking of the system fault trees and manipulations of the results (cutsets) developed from the fault trees. The personal computer (PC) version of Sets Equation Transformation System (PCSETS) software was used to generate the system and level 1 sequence equations from the fault and event trees and then solve the equations in order to determine

numerical frequencies for each sequence. Another EPRI code, the Modular Accident Analysis Program (MAAP), was used to support success criteria and to determine best estimate analysis of reactor and containment response during accident sequences. PCSETS was used to quantify the CETs, carrying the level 1 equations through to final containment results.

A review and update of the level 1 system models and documentation to incorporate recent modifications, procedure changes, and recent operating history were conducted prior to final quantification of the front-end analysis. This was done to ensure that the IPE accurately modeled the current plant configuration. Sensitivity studies were conducted to assess the impact of key assumptions.

A more detailed discussion of the methodology used and the products developed by the IPE study is found in Section 2.3.

1.4 Summary of Major Findings

1.4.1 Clinton-Specific Level 1 Analysis

No vulnerabilities or new or unusual means were discovered by which core damage or containment failure could occur.

The overall mean core damage frequency (CDF) for CPS is 2.6×10^{-5} per reactor year. This includes internal flooding, but not other external events such as earthquakes. These will be analyzed in the Individual Plant Examination for External Events (IPEEE). The CPS CDF for internal events is well below the NRC's proposed safety goal of 1×10^{-4} per year. The Clinton IPE results were thoroughly examined for design conditions and operating modes that contribute unduly to core damage or poor containment performance. The most significant contributor to core damage was determined to be station blackout (SBO). This result is typical for many boiling water reactor (BWR) PRAs. The low probability of this sequence shows good plant capability to

respond to this potentially hazardous loss of power event. Chapter 6 provides additional discussion on significant sequences and insights.

Figures 1.4-1 through 1.4-3 and Tables 1.4-1 through 1.4-3 show that station blackout and transients are the most significant contributors to CDF. CDF due to anticipated transients without SCRAM (ATWS), loss of coolant accidents (LOCA), and internal flooding are of much less importance.

Of the set of core damage sequences composing the overall CDF, six sequences, as shown on Table 1.4-4, were above the sequence screening criteria from Appendix 2 of Generic Letter 88-20 of $1.0E-6$ per reactor year. These and other sequences which CPS considers important are examined in more detail in Section 3.4.1.

A breakdown of CDF by initiating events is presented in the following table.

TABLE 1.4-1

CORE DAMAGE FREQUENCY BY INITIATOR

<u>Initiating Event</u>	<u>Initiating Event Frequency*</u>	<u>Core Damage Frequency*</u>	<u>Percent of Total</u>
Transients			
Without Isolation	4.7	4.8E-06	18%
With Isolation	1.7	4.2E-06	16%
Loss of Feedwater	0.6	9.6E-07	4%
Loss of DC Bus	1.39E-02	1.2E-06	5%
Loss of Instrument Air	4.32E-03	1.0E-08	0%
Loss of Service Water	1.75E-03	1.9E-07	1%
Total Transients		<u>1.1E-05</u>	<u>43%</u>
Loss of Off-Site Power			
Non-SBO	8.40E-02	2.4E-06	9%
SBO	N/A	9.8E-06	37%
Total LOOP		<u>1.2E-05</u>	<u>46%</u>
Loss of Coolant Accidents			
Large	1.00E-04	<1 E-09	0%
Medium	3.00E-04	1.3E-08	0%
Small	1.00E-03	<1 E-09	0%
IORV	1.00E-01	1.1E-06	4%
Total LOCA	1.01E-01	<u>1.1E-06</u>	<u>4%</u>
ATWS	N/A	1.4E-07	1%
Interfacing System LOCA	5.00E-06	<1 E-09	0%
Internal Flooding		1.6E-06	6%
Total Core Damage Frequency		<u>2.6E-05/Reactor Year</u>	

* Frequencies are per reactor year

TABLE 1.4-2

CORE DAMAGE FREQUENCY BY INITIATOR CATEGORY

<u>Initiator Class</u>	<u>Core Damage Frequency</u>	<u>Percent of Total</u>
Transients (including non-SBO LOOP)	1.4E-05	52%
LOCA (including IORV & ISLOCA)	1.1E-06	4%
SBO	9.8E-06	37%
ATWS	1.4E-07	1%
Internal Flooding	1.6E-06	6%

TABLE 1.4-3

CORE DAMAGE FREQUENCY BY ACCIDENT CLASS

<u>Accident Class</u>	<u>Core Damage Frequency</u>	<u>Percent of Total</u>
Transients - high pressure (IA)	9.8E-06	37%
Station Blackout (IB)	9.8E-06	37%
Transients - low pressure (ID)	5.7E-06	21%
LOCAs - high pressure (IIIB)	1.3E-08	0%
LOCAs - low pressure (IIIC)	1.1E-06	4%
ATWS events (IV)	1.4E-07	1%
Containment bypass (V)	<1.0E-09	0%
Overall Core Damage Frequency	2.6E-05/reactor year	

Pie Charts developed from the above data are shown in Figures 1.4-1, 1.4-2, and 1.4-3.

CORE DAMAGE FREQUENCY

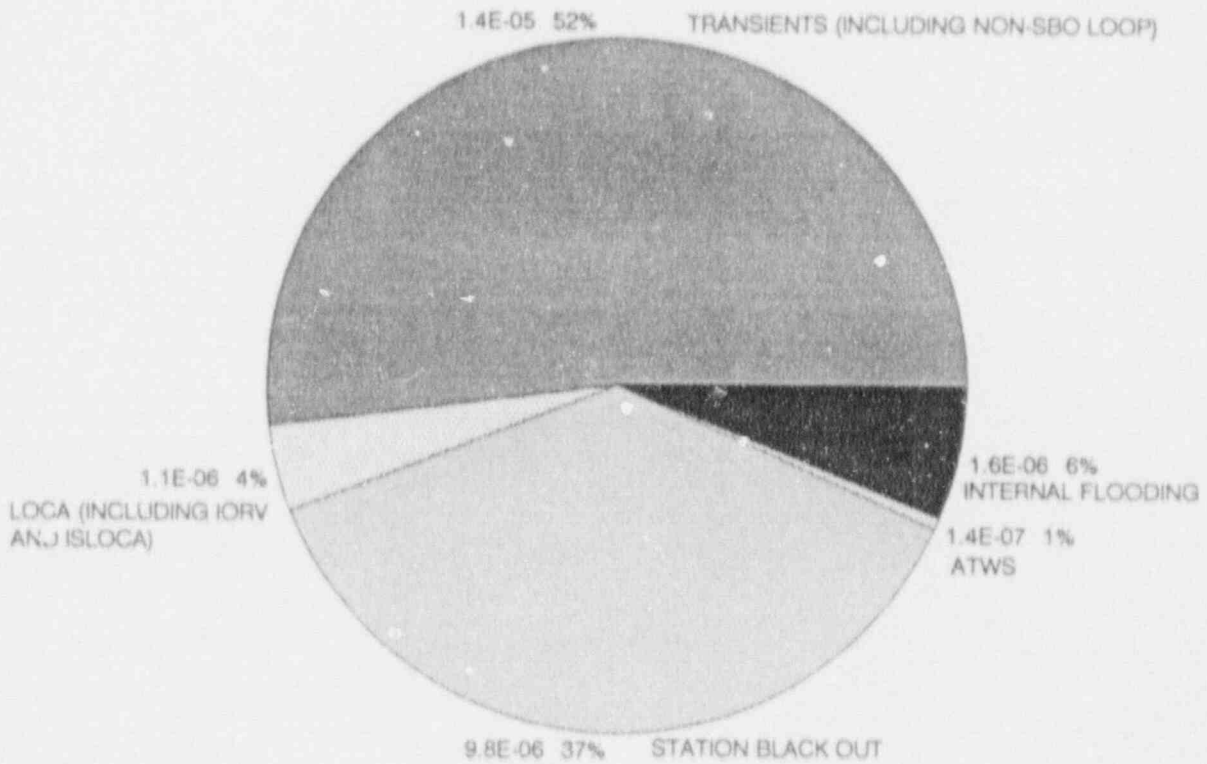

Figure 1.4-1
Core Damage Frequency by Initiator Category

CORE DAMAGE FREQUENCY

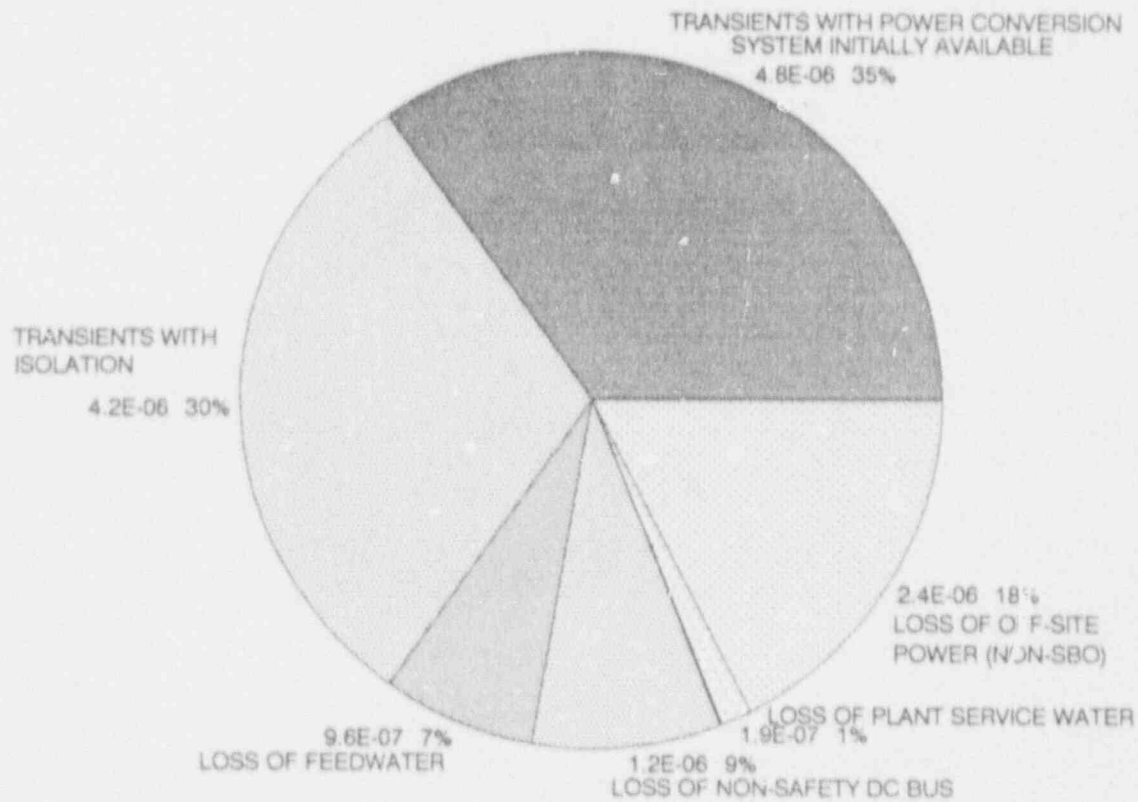

Figure 1.4-2
Transient Core Damage Frequency by Specific Initiator

CORE DAMAGE FREQUENCY

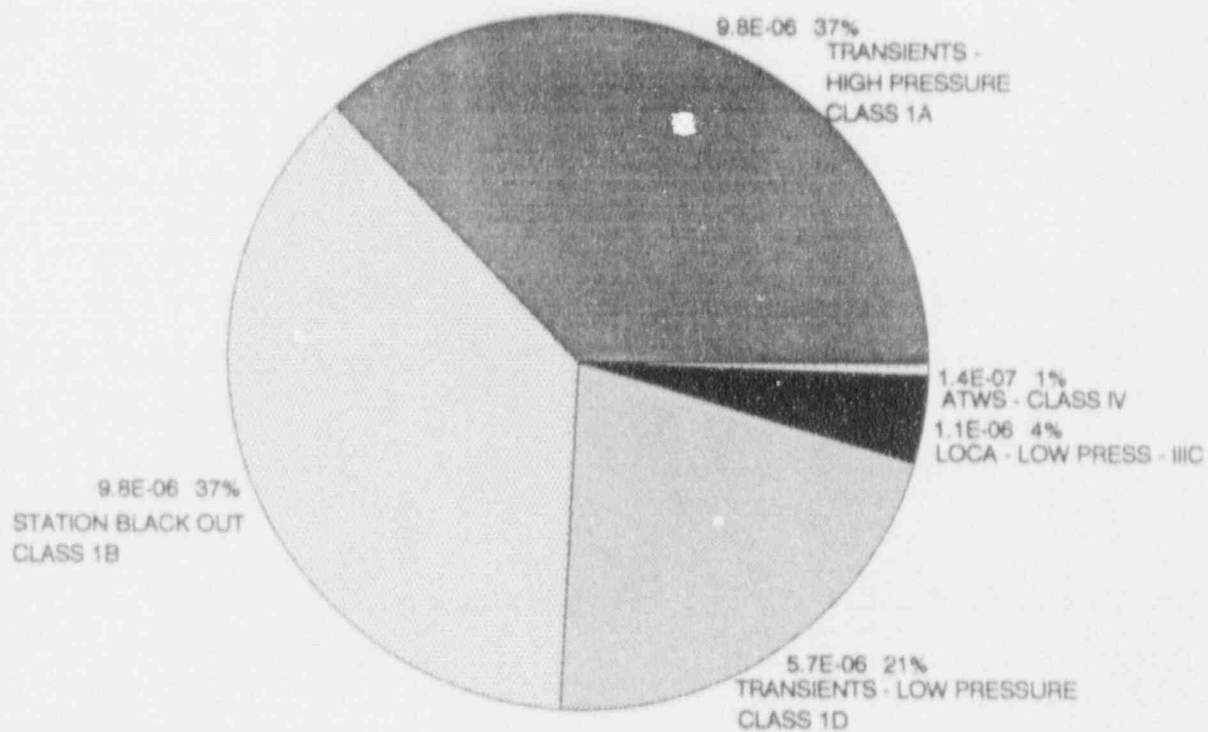

Figure 1.4-3
Core Damage Frequency by Accident Class

TABLE 1.4-4

Dominant Accident Sequences

<u>Sequence</u>	<u>Description</u>	<u>Frequency/ Percent</u>
TLU1U3	Short-term Station Blackout, initiated by Loss Of Off-site Power, SCRAM successful, both division 1 & 2 Diesel Generators fail, HPCS & RCIC fail.	5.24E-06/ 20.1%
TLU1L4DG1DG2	Long-term SBO, initiated by LOOP, SCRAM successful, division 1 & 2 DGs fail, HPCS fail RCIC runs until battery fail.	4.59E-06/ 17.6%
T2U2UX1	Transient without isolation, all high pressure injection fails, depressurization fails, low pressure injection systems not able to be effective.	3.39E-06/ 13.0%
T3U2UX1	Identical to T2U2UX1, except main condenser is also lost; results are the same.	3.03E-06/ 11.6%
INTERNAL FLOODING	Combination of several scenarios, predominantly Feedwater line break in steam tunnel which disables RCIC as well as Feedwater	1.60E-06/ 6.1%
DCQ2U2UV	Loss of non-safety DC bus with SCRAM caused by loss of FW control, main condenser is lost, all injection sources lost	1.14E-06/ 4.4%
T4Q1U1V	Open relief valve initiator with loss of feedwater delivery & a1 high and low pressure injection systems. In many cases, failure of injection is because of lack of AC power. These sequences are included here instead of in the SBO sequences because of the LOCA effects of the open relief valve.	1.06E-06/ 4.1%

No sequences fall into accident Class II (Loss of Containment Heat Removal) because analysis (Section 3.1.2.3) shows that the Emergency Core Cooling System (ECCS) pumps are capable of pumping from the suppression pool even under saturated conditions.

The analysis of CDF yields, in addition to the identification of sequence contributions, a way to measure the importance of various systems in averting core damage. No single component, system, or action was found to predominate in contribution to core damage. The following list shows the most important systems from this analysis.

- High Pressure Core Spray
- Reactor Core Isolation Cooling
- Diesel Generators
- Automatic Depressurization System
- Fire Protection Injection

The human interaction events which have the greatest effect on core damage frequency are as follows:

- Manual reactor depressurization.
- Recovery of off-site power and diesel generators and
- Manual back-up to the automatic start of the shutdown service water pumps

1.4.2 Clinton-Specific Level 2 Analysis

The level 1 core damage state sequences are binned (grouped) based on the potential impact on containment functions so that the level 1 results are carried over into the containment analysis. These bins are illustrated in Figure 1.4-3. Details of the binning process are contained in Section 4.3.

Event trees were then constructed to evaluate actions or events that directly affect containment performance. An individual containment event tree (CET) was then constructed to model each accident class. Progression through the CETs eventually reaches an end condition referenced as a plant damage state.

1.4.3 Containment Performance Findings

For plant damage states for which containment failure occurs, the radionuclide release mode is also determined for use in the calculation of the radionuclide release source term. The containment fails in only 5% of the sequences in which core damage occurs (Figure 1.4-4). The conditional containment failure frequency is very small for CPS primarily because the containment is very large compared to similar plants and has greater strength than other BWR-6 plants because of additional concrete reinforcement.

Figure 1.4-5 shows the fractions of containment failures that fall into various classifications. The upper left figure shows the containment conditions at the end of the sequence (plant damage state, Section 4.3.3). The upper right figure shows the fraction by release mode (i.e., scrubbed or not, etc., Section 4.3.4). The lower figure shows the fractions that can be classified as moderate release (ST II) or major release (ST III) (Section 4.3.5). As the figure shows, the frequency of major release is $7.52E-7$, which is well below the NRC goal of $1.0E-6$. Further analysis of insights relating to containment failure is included in Section 6.4.

CONTAINMENT FAILURE

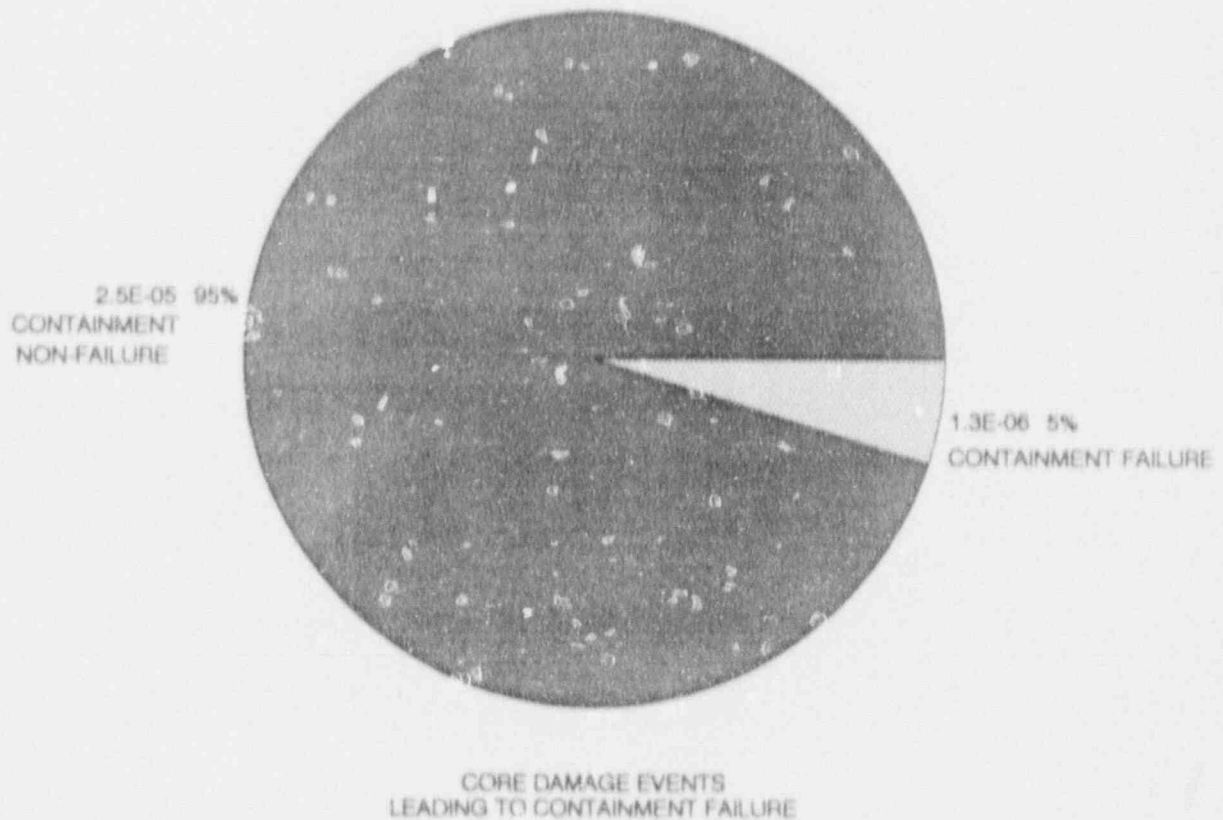

Figure 1.4-4
Containment Failure Fraction

CONTAINMENT FAILURE

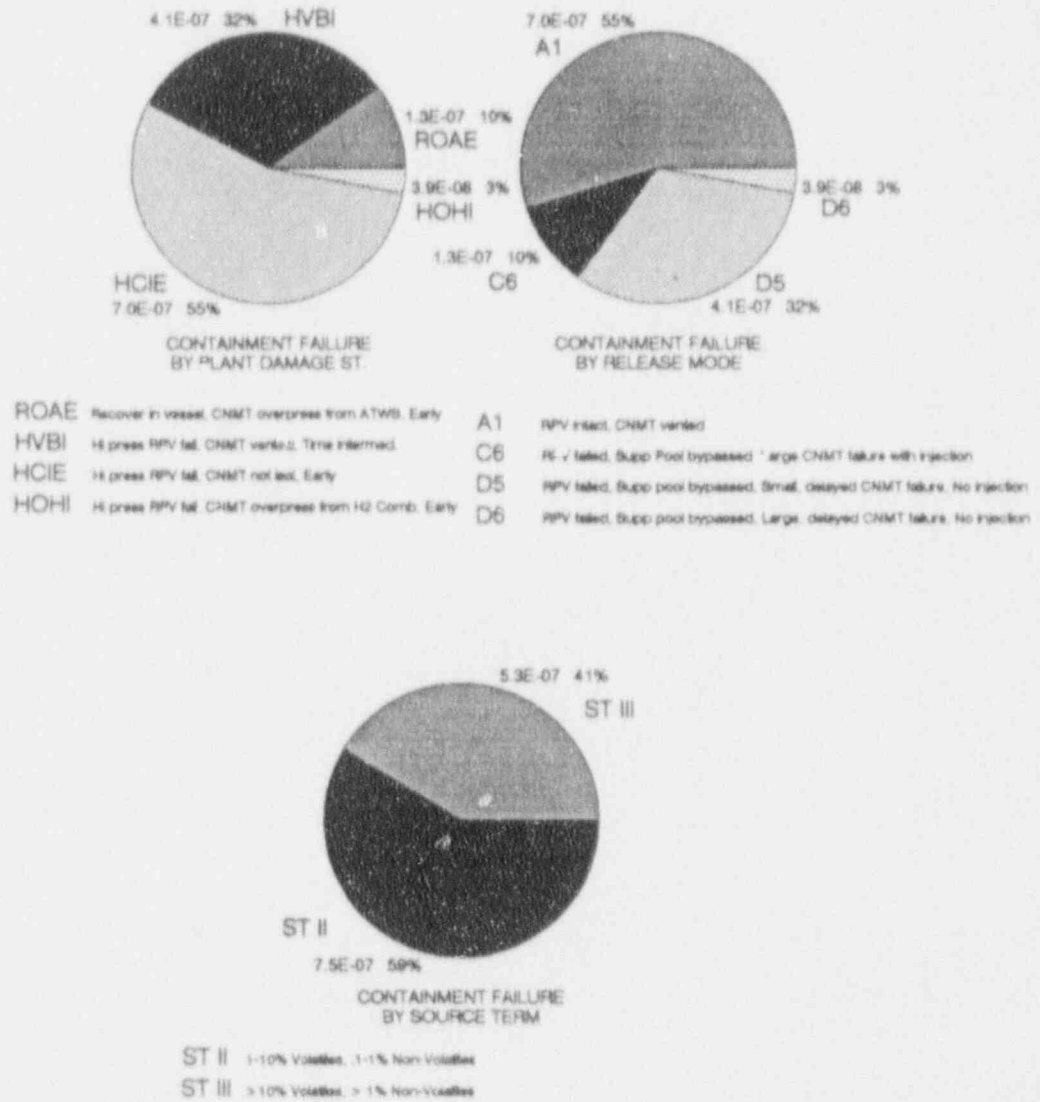

Figure 1.4-5

1.4.4 Consistency With Other PRAs

Several PRAs have been performed on a variety of plants over the years. These studies resulted in core damage frequency estimates from $2.8E-4$ to $4.0E-6$. Many of these studies were for PWRs. The BWR results ranged from $5.5E-5$ to $4.0E-6$. The CPS result of $2.6E-5$ falls within both ranges. Other BWR-6 studies, including Kuosheng and Perry, ranged from $3.4E-5$ to $4E-6$.

THIS PAGE

INTENTIONALLY

LEFT BLANK

2. EXAMINATION DESCRIPTION

2.1 Introduction

This section describes how the IPE analysis was performed in order to ensure that the objectives of NRC Generic Letter 88-20 were met. In addition to compliance with the Generic Letter, the IPE was developed to provide a decision optimization tool that can be used to aid in achieving corporate goals related to the continuation and enhancement of the safe, reliable, and efficient operation of the plant.

2.2 Conformance with Generic Letter and Supporting Material

The program objectives for the CPS IPE are as follows:

- 1) Develop an overall appreciation of severe accident behavior,
- 2) Understand the most likely severe accident sequences that could occur at the Clinton Power Station,
- 3) Gain a more quantitative understanding of the overall probability of core damage and radioactive material releases, and
- 4) If indicated, reduce the overall probability of core damage and radioactive material releases by appropriate modification to hardware and procedures.

To accomplish the IPE program objectives, a level 1 PRA was performed with containment performance analysis in accordance with Generic Letter 88-20. The evaluation was performed and controlled by a team of IP engineers intimately familiar with CPS. An independent in-house review was performed at several key stages of the process. Review and technical advice were supplied, as necessary, by consultants. Specific information on the team makeup, structure, and experience level, and the review processes is included in Sections 5.1. and 5.2. Containment

severe accident phenomenological issues, as identified in Generic Letter 88-20, were analyzed during the course of the CPS IPE. Other specific issues, such as unresolved safety issue (USI) A-45, "Shutdown Decay Heat Removal Requirements", were also addressed in the CPS IPE.

This submittal is formatted in accordance with the guidance of NUREG-1335, "Individual Plant Examination Submittal Guidance".

The CPS IPE results will be used in an Accident Management Program as guidance on this matter is developed.

2.3 General Methodology

The Level 1 PRA conforms to guidelines provided in NUREG/CR-2300, "PRA Procedures Guide"; NUREG/CR-2815, "Probabilistic Safety Analysis Procedures Guide"; and NUREG-1335, "Individual Plant Examination Submittal Guidance".

The following paragraphs highlight the main topics of the methodology used to perform the CPS evaluation.

2.3.1 Initiating Events

The CPS IPE study was started with a review of industry and plant-specific data to determine what occurrences can disrupt normal plant operation sufficiently to induce a plant trip. CPS Licensee Event Reports (LERs) were reviewed for events which did happen (or could have happened) at power and caused (or could have caused) a plant shutdown. Industry data included other published PRAs, NUREGs, EPRI documents, etc., in addition to domestic BWR-6 LERs.

There were three phases in the initiating event identification process: (1) identification of possible events as indicated above, (2) grouping of the identified events based on their similarity for modeling and impact on risk, and (3) quantification of the frequency of initiating events. The initiating events that are identified in Section 3.1 were used to develop the CPS event trees.

2.3.2 Event Trees

The Level 1 event trees model the plant's major systems or functions that are available to prevent core damage for a given initiating event. Event trees generally start with an initiating event and are logic diagrams using branches (nodes) to depict success or failure of various systems or actions used to mitigate the effects of the initiating event. Each combination of successes and failures, called accident sequences, was evaluated to determine whether it would lead to core damage. Event trees were developed for each of the initiating event groups. The level 1 event trees address event sequences up to the point at which core cooling is lost. The event trees are based on the small event tree approach which includes certain operator actions, where appropriate.

2.3.3 Fault Trees

In order to evaluate the branches of the event trees, system failure diagrams were developed. These diagrams of systems are called fault trees and contain detailed system failure information. Section 3.2 discusses the front-line and support systems modeled during this study. Fault trees were developed for each of the front-line and support systems. These system fault trees were then linked to properly account for system dependencies under different initiating events.

Failure modes in the fault trees include hardware failures, maintenance unavailabilities, support and dependency failures, common cause failures, and human errors.

In order to facilitate future applications of the IPE, maintenance unavailabilities are separated into two subgroups, preventive and corrective, either of which can cause a component to be unavailable when required during plant operation. Restoration from maintenance errors is also modeled for cases in which component non-operability is not readily apparent.

The treatment of dependent failures is considered throughout the analysis. Dependencies between components tend to increase the frequency of multiple, concurrent component failures. Since essentially all important accident sequences that can be postulated for nuclear reactor systems involve the hypothesized failure of multiple components, systems, and containment barriers, dependent-failure analysis is an extremely important aspect of the PRA study.

Dependent failures are included in the IPE by two primary methods, fault tree linking and common cause modeling. In addition, dependency among human failure actions is included in the sequence evaluation as discussed in Section 3.3.3.1.7.

Fault tree linking ensures that all support system and front-line interconnection dependencies in each fault tree are complete.

Common cause failure analysis involves defining additional events to be included in the system fault trees. The primary benefit from this analysis is the modeling, in the fault trees, of potential failure of redundant components from a single event. This is a more realistic treatment of the important combinations of failures for plant risk than one in which the failures of redundant components are assumed to be independent events.

Common cause failure analysis used the "Multiple Greek Letter" (MGL) model to define conditional probabilities of the failure of additional components in a common cause group, given that at least one has failed.

Human Reliability Analysis is necessary to consider the human tasks that are performed under normal and abnormal operating conditions. The tasks considered fall into three groups as follows:

- 1) Pre-accident errors, such as improper calibration and failure to restore equipment after maintenance or testing.
- 2) Operator acts of omission, which are failures to take required actions. (Acts of commission, taking incorrect or wrong actions where none are required, are not modeled.)
- 3) Repair and recovery of failed systems.

Errors might be made during or after maintenance, calibration, or testing in the normal operation of the plant and may occur both inside or outside the main control room. For abnormal operations, most of the safety-significant errors modeled occur in the main control room.

2.3.4 Data Analysis

After the development of the fault trees, probabilities were assigned to each of the modeled component or human failures. These probabilities were required in order to determine the overall failure probability of a system. Data for quantitative evaluation of the models were collected at various stages of the study. Even though limited operating history for Clinton was available, plant-specific data were analyzed and used in appropriate cases. Industry generic data were used for most component failure rates. The methodology used to analyze data

has been documented in order to provide the foundation for future updates of the PRA as more plant-specific data becomes available.

2.3.5 Quantification

After failure probabilities are determined for each basic event, the fault tree and event tree models are solved. This is done using PCSETS. Each system is first solved with all its dependencies. Then the event tree headings are solved by combining systems as necessary (e.g., V [low pressure injection] heading - Low Pressure Core Spray, Residual Heat Removal, Condensate, and Condensate Booster). Then, each sequence on the event trees is solved by combining the initiation frequency with appropriate system failures and successes based on the event tree structure. SETS is also used to combine similar sequences (i.e., all high pressure sequences) and to apply recoveries. Recoveries include both restoration of faulted systems and power recovery based on empirical data; and use of additional systems per procedure, such as Control Rod Drive (CRD) and Fire Protection. Finally, SETS is used to create cutsets which are imported into the CAPTA cutset editor for review and evaluation.

2.3.6 Containment Analysis

The general approach in the containment analysis is the simplified containment performance methodology discussed in EPRI RP 3114-29, "Generic Framework for Individual Plant Examination (IPE) back-end (level 2) analysis". This methodology starts with a review of the plant conditions existing in the various level 1 event tree end states that identify core damage. These end states were then grouped (binned) by common thermal-hydraulic, equipment availability and timing characteristics. The various groups of level 1 event tree end states, called accident classes, form the beginning states for the containment event trees (CETs).

CETs provide a quantitative logic model for examining the spectrum of plausible severe accident progressions and provide the framework for evaluating the deterministic outcomes of specific accident sequences.

The CET structure emphasizes what an operator can see and control rather than phenomena (e.g., "Is reactor at high or low pressure?" versus, "Does direct containment heating occur or not?"). Therefore, the headings on the CETs emphasize sources of water and methods to control production and removal of energy.

Progression through the CETs eventually reaches a plant damage state (CET end state). For sequences in which containment failure occurs, the release mode is also determined for use in the calculation of the radionuclide release source term.

Release mode defines whether the release is scrubbed or not, timing of the release, and size of the release. Accident sequences are grouped by plant-damage states, and containment failure/release modes are combined into release categories for off-site consequence analysis. The Modular Accident Analyses Program (MAAP) was the principal tool used to determine the end state of each CET sequence. CET end states and containment release modes are discussed in more detail in the back-end analysis, Section 4.3. CETs have a structure similar to that of the level 1 event trees. However, the CETs begin with an end state from the level 1 analysis and represent containment performance as well as radionuclide release source term estimates resulting from containment failure.

Containment phenomenology issues, including the specific issues identified in Generic Letter 88-20, Attachment 2, were evaluated for applicability to Clinton. Where applicable, they have been included in the appropriate CET headings. The present understanding of some severe accident phenomena is still limited. Therefore, the generic framework employed in this study was

designed to facilitate sensitivity analyses to reflect different viewpoints on the severe accident phenomena. The phenomenology issues were evaluated in detail, not only for applicability to CPS, but also for the extent of the impact of certain issues on the containment results.

2.3.7 Documentation

In order to capture the thought processes and methods as the study progressed, reports were developed during the different stages of the study. These reports are referred to as interim products and include the following:

- Initiating Events Report
- Event Tree Report
- System Fault Tree Report
- Data Analysis Report
- Quantification Report
- Containment Analysis Report

System Notebooks were developed during the course of the IPE to document information used in the study.

Each of the above-listed reports has been reviewed as described in Section 5.1 for accuracy and completeness. These reports form part of the second tier of documentation and serve as the foundation for future applications and updates. They are structured specifically to document methods which can be used for subsequent applications.

Information from these reports has been directly used in development of this submittal.

2.4 Information Assembly

2.4.1 Plant Layout

Clinton is a Boiling Water Reactor (BWR) rated at 2894 megawatts thermal (Mwt). It is a BWR-6 with a Mark III containment. Some of the major plant features include the following:

Inventory Make-up Systems

- 4 motor driven low pressure ECCS trains (LPCS & LPCI) rated approximately 5000 gpm each.
- 1 motor driven high pressure ECCS train (HPCS) rated approximately 5000 gpm.
- 1 steam driven high pressure system (RCIC) rated approximately 600 gpm.
- Feedwater delivery system consisting of 2 turbine driven and 1 motor driven pump with 4 sets of motor driven condensate/condensate booster pumps.

Main Steam System

- 16 safety/relief valves, 7 of which are Automatic Depressurization System (ADS) Valves.
- 35% turbine bypass capability.

Electric Power Systems

- 4 off-site power circuits (3 lines at 345 kv through the switchyard and 1 line at 138 kv bypassing the switchyard).
- 3 emergency, safety-related AC buses.
- 3 standby diesels.
- 4 safety-related batteries.
- 2 non-safety-related batteries.
- 4 hour battery life (with load shedding).
- Dedicated switchyard with 2 separate buses.

* CPS Mark III Containment

- Steel-lined reinforced concrete containment, with a volume of 1,550,000 ft³.
- Drywell structure with a volume of 246,500 ft³ enclosed by the containment.
- Suppression pool with a volume of 135,700 ft³, which communicates between the drywell and containment.
- 2 trains of containment spray, suppression pool cooling or shutdown heat removal.
- A reinforced concrete basement of over 10 feet in depth.

Various support systems which are directly necessary to support front-line system operation, including cooling water, air, room cooling, are not mentioned here explicitly but are included in the IPE model. The IPE is based on the plant as described in the USAR and currently configured and operated.

2.4.2 IPE/PRA Review

No previous PRA evaluation has been performed on CPS. However, two BWR-6 PRAs were reviewed as part of this project. These were the Kuosheng PRA and NUREG 4550 on Grand Gulf.

PRAs have been previously completed for several different reactor types using different risk analysis methods. These sources were carefully screened to determine applicability of the information to Clinton.

A source that was reviewed extensively throughout the IPE for applicability to Clinton was the documentation of the NRC risk study performed on Grand Gulf, another BWR-6. System comparisons between the two plants were performed and documented in the IPE system notebooks. Generally, the CPS IPE used more detailed system models incorporating more common cause failures, human actions, and support system dependencies. Several balance of

plant (BOP) system models were constructed for CPS that the Grand Gulf study did not include.

A second important source of information was the Boiling Water Reactor Owners Group (BWROG) IPE subcommittee. Since 1989, representatives of the four domestic BWR-6s have been sharing IPE insights, problems, and results. Potentially significant dependencies or insights found at any of the BWR-6 plants were reviewed for applicability to the other plants. If a difference was found, then the reasons for the difference were determined for greater understanding.

Another useful source of information was an EPRI IPE Technical Assistance Package. This source included a repository of prior PRA results, including NUREG-1150, as well as summaries of NRC reviews of earlier industry-sponsored PRAs. The IDCOR Technical Report 86.3, "IPE Methodology", provides a source of information from previously published PRAs. These packages, along with the results of the Grand Gulf PRA, were referenced frequently during the course of the CPS IPE effort.

Comparisons were also made to results of PRAs that were issued by the BWR Owners' Group and by individual utilities, such as the Kuosheng Nuclear Station Unit 1 PRA, mentioned previously. Reference works were used to gain insights from the analysis techniques and assumptions used by the studies, rather than the numerical results.

2.4.3 Reference Documentation

Documents used during the course of this IPE are listed below. These documents are maintained either in the IPE team library, on-site departmental libraries, or on the Illinois Power mainframe computer.

TABLE 2.4-1

REFERENCE DOCUMENTATION

<u>DOCUMENT</u>	<u>INFORMATION</u>
System Descriptions	General System Design Capabilities, Operating Features
Clinton Drawings Piping and Instrument Drawings Electrical Drawings Vendor Drawings	System Components and System Interconnections
Master Equipment List	Instrument and Equipment Lists Hardware Characteristics
Maintenance Work Requests	CPS-Specific Failure Data
Operations Tagout Logs	System and Component Unavailability data
Surveillance Logs	Test Frequencies
Updated Safety Analysis Report	Initiating Events, Success Criteria, and Plant Response
Technical Specifications	Test Frequencies
Procedures Normal Off-Normal Emergency Maintenance	System Operations, Maintenance Activities, Operator Actions, and Plant Information
Licensee Event Reports, Post Scram Trip Reviews, and Significant Operating Event Reports	Initiating Events, Failure Data and Plant Response
Nuclear Power Reliability Data System (NPRDS)	Generic Failure Data
Other Reports BWR Owners Group Nuclear Safety Analysis Center Industry Degraded Core Rulemaking Electric Power Research Institute NUREG (Various) Nuclear Management and Resources Council	Submittal contents, Organization, Guidance, and Technical Details

TABLE 2.4-1 (Cont'd)

REFERENCE DOCUMENTATION

<u>DOCUMENT</u>	<u>INFORMATION</u>
Computer based Modular Accident Analysis Program (MAAP)	Success Criteria
EPRI NP-3835, "Determination of Several LWR Realistic Success Criteria for PRA"	Success Criteria

2.4.4 Walkdowns

Plant walkdowns were performed for the IPE to verify system information accuracy, identify spatial or unusual characteristics of individual components or their locations, and identify potential recovery actions. A flooding walkdown determined both the sources and potential effects of flooding including Interfacing System Loss of Coolant Accident (ISLOCA) effects. Internal flooding data were collected to supplement the Sargent & Lundy Internal Flooding Report. The containment and drywell walkdowns were conducted to evaluate building characteristics and validate Modular Accident Analysis Program (MAAP) parameter file information. A Human Reliability Assessment (HRA) walkdown included an expert in this field to assist the IPE team. Simulator walkdowns by a member of the IPE team and a consultant were also included for operator actions, both when an operating crew was in training and when no simulations were in progress.

Documentation of observations and insights obtained during the walkdowns was accomplished mainly through the use of checklists. A walkdown report was developed from the observations of the walkdowns and includes the checklists. A videotaped recording of the containment and some of the ECCS rooms is part of the IPE reference documentation. The walkdowns provided an overall verification of system models, operator actions, and flooding events. The IPE team, located at the plant site, performed additional walkdowns as necessary to answer specific questions as they arose.

The combination of interim products, referenced documents, and collective experience of the IPE team provides an excellent foundation for the IPE and future PRA analyses and applications. It is IP's intent to periodically update the CPS PRA and use it to improve plant safety and economy.

3. Front-End Analysis

This section contains a description of the Clinton Power Station (CPS) Level 1 Probabilistic Risk Assessment (PRA). A discussion on the identification of CPS initiating events, development of fault trees, and quantification results is included.

3.1 Accident Sequence Delineation

3.1.1 Initiating Events

The first step taken in the development of the CPS accident sequence definitions was the identification of initiating events. An initiating event results in a reactor trip, either automatically or by manual action. A reactor trip is defined as a rapid shutdown of the reactor and does not include controlled orderly shutdowns such as those required by technical specifications. The study considered only those events which can occur during power operation. Initiating events which have occurred during plant shutdown or refueling were also reviewed to determine if they could initiate a reactor trip during power operation.

The CPS Individual Plant Examination (IPE) team developed a comprehensive initiating event list to assure completeness of the CPS PRA. This list was used to define the accident sequence event trees which, in turn, were used to determine what system fault trees were necessary.

The initiating event identification process began by defining the general categories of plant events to be considered as initiating events in the PRA. This task consisted of the following four sub-tasks:

- a. Developing an initiating event identification flow chart.

- b. Reviewing existing PRAs and other industry information sources.
- c. Reviewing CPS operating experience and the operating experience of plants with similar design. This included a review of Licensee Event Reports (LERs) from the other domestic Boiling Water Reactor (BWR) Mark III plants; River Bend, Grand Gulf, and Perry.
- d. Obtaining feedback from IPE team members and plant operating personnel.

The initiating events were then grouped based on their general effect on the plant. Initiating event grouping guidelines, shown in Table 3.1-1, were used to accomplish this task. The four categories used at C 3 are 1) loss of coolant accidents (LOCAs), 2) Transients, 3) Special Initiators, 4) Other. The "other" category includes anticipated transient without SCRAM (ATWS) and station blackout (SBO). The above categories were analyzed as part of the internal events PRA. External events, with the exception of internal flooding, are not part of the CPS IPE. External events will be studied and reported separately in the CPS Individual Plant Examination for External Events (IPEEE).

Critical support system failures are treated as initiating events if their failure results in a reactor trip and causes the degradation or loss of one or more front-line systems. These events are called special initiators. Critical support systems that meet this definition include Plant Service Water (WS), Instrument Air (IA), and non-safety D.C power. A description of the front-line and support systems is contained in Section 3.2.

Table 3.1-2 lists the initiating events in their appropriate grouping, along with the initiating event frequency. Justification for grouping the initiating events in this manner is as follows:

3.1.1.1 Loss of Coolant Accidents (LOCAs)

This category is divided into two sub-categories which have significantly different effects on plant response. These sub-categories are Loss of Coolant Accidents (LOCAs) which release primary system coolant inside containment and LOCAs which release primary system coolant outside containment. The initiating events causing a loss of primary system inventory inside containment were further sub-divided into small, medium and large break LOCAs, and inadvertent/stuck open relief valve. The subcategory of LOCA identified which would release primary coolant outside the containment is an interfacing system LOCA (ISLOCA). The definition of these events is as follows:

1. Small Break LOCA - A break in a primary system in which the capacity the Reactor Core Isolation Cooling (RCIC) system is sufficient to maintain coverage of the core. The reactor does not rapidly depressurize.
2. Medium Break LOCA - A break in a primary system in which the capacity of the RCIC System is not sufficient to maintain coverage of the core. If the High Pressure Core Spray (HPCS) system is unavailable, the reactor must be depressurized so that low pressure injection systems can be used.
3. Large Break LOCA - A break in a primary system in which the reactor vessel will rapidly depressurize and the low pressure injection systems are used to maintain coverage of the core.
4. Interfacing System LOCA - A breach of a high pressure to low pressure interface on systems that connect with the primary system and penetrate the primary containment.

5. Inadvertent/Stuck Open Safety Relief Valve (IORV) - While this event is initiated as a transient, it is included here because many of the characteristics of this event are similar to other types of LOCAs. These events occur when a safety relief valve opens or remains open when not required due to operator error or equipment failure. The resulting uncontrolled steam flow from the reactor vessel is such that the capacity of the RCIC system is insufficient to maintain coverage of the core.

3.1.1.2 Transients

Transients are events in which the loss or degradation of a system or function results in a reactor SCRAM. Transients analyzed include the following:

1. Loss of Off-site Power (LOOP) - All power to the plant from external sources (345 KV and 138 KV transmission lines) is lost due to off-site or onsite failures. Modeling the loss of off-site power (LOOP) in this manner is conservative because the loss of the 138 KV source alone would not cause a reactor SCRAM and the safety related buses would remain energized from the 345 KV source. The loss of the 345 KV source alone would lead to a reactor SCRAM, but the safety related buses would remain energized from the 138 KV source. However, since specific data was not available to quantify the loss of only one bus, the loss of both sources was modeled. Note that this event assumes that either the division 1 or 2 diesel generator successfully starts and runs. If neither succeeds then the event is evaluated as a station blackout (SBO).
2. Loss of Feedwater - A transient that causes a complete or partial loss of Feedwater (FW) flow to the reactor

resulting in a reactor SCRAM due to low reactor water level. Events in this group include the following:

- a) Loss of All Feedwater - The simultaneous loss of all main FW flow to the reactor (Except that loss of FW caused by a loss of off-site power was modeled in the Loss of Off-site Power Event).
 - b) Low Feedwater Flow - Insufficient FW flow to the reactor for a given reactor power resulting in a SCRAM on low reactor water level. Included are all events which lead to insufficient FW flow except those which result from a loss of an operating FW pump.
 - c) Partial Loss of Feedwater - The loss of one FW pump, one Condensate (CD) pump or one Condensate Booster (CB) pump resulting in a reduction of FW flow to the reactor. The reactor SCRAMs on low reactor water level.
3. Transients with Isolation - The isolation of the reactor from the main condenser so that the main condenser is not available as a heat sink for reactor vessel pressure/temperature control after a reactor SCRAM. In this situation, the safety relief valves (SRVs), RCIC, and Emergency Core Cooling (ECCS) systems are used for reactor pressure/temperature control. Events in this group include the following:
- a) Main Steam Isolation Valve (MSIV) Closure - The closure of all main steam isolation valves (MSIVs) either automatically or by operator action.

- b) Inadvertent Closure of One MSIV - The closure of one MSIV due to operator error or equipment failure.
- c) Partial MSIV Closure - The partial closure of one MSIV due to operator error or equipment failure.
- d) Loss of Condenser Vacuum - Vacuum in the main condenser is lost due to equipment failure. The MSIVs will eventually close.
- e) Turbine Trip with Turbine Bypass Valve Failure - An automatic or manual trip of the main turbine with the turbine bypass valves failing to open. Events included are generator load rejection and an intentional turbine trip.
- f) Turbine Bypass Valves Fail Open - The inadvertent opening of turbine bypass valves due to equipment failure or operator error. This results in a decrease in the reactor vessel level, MSIV closure on low main stream line pressure, and reactor SCRAM.
- g) Turbine Pressure Regulator Failure - The controlling pressure regulator or backup pressure regulator fails in an open or closed direction. Failure in the open direction will cause the main turbine control valves and bypass valves to open resulting in a low main steam line pressure isolation of the main condenser. Failure in the closed direction will result in closure of the main turbine control valves and inhibit opening of the turbine bypass valves. This causes high reactor pressure.

4. Transients Without Isolation - The main condenser remains potentially available as a heat sink for reactor vessel pressure/temperature control after a reactor SCRAM. The main condenser is considered only potentially available because other failures independent of the transient without isolation initiator may eventually cause a loss of the main condenser. Events in this group include:
- a) Manual Shutdown - The initiation of a manual SCRAM either as required by plant events or due to operator error.
 - b) Turbine Trip with Turbine Bypass Valves Open - An automatic or manual trip of the main turbine either due to equipment failure or operator error. The turbine bypass valves function as designed. Events included are generator load rejections and intentional main turbine trips.
 - c) Reactor Recirculation Control Failure - The failure of a flow controller, either in one Reactor Recirculation (RR) loop or the master flow controller, causing an increase or decrease in flow to the reactor core. An increase in flow results in a high neutron flux SCRAM of the reactor. A decrease in flow results in a reactor vessel level transient with a reduction in reactor power. The main condenser remains available as a heat sink in either case.
 - d) Trip of Both Reactor Recirculation Pumps - The simultaneous loss of both RR pumps and resultant reactor vessel level swell.

- e) Abnormal Startup of an Idle Reactor Recirculation Pump - An idle RR pump starts at an improper power and flow condition resulting in a neutron flux spike.
- f) Feedwater Flow Increase - An event that causes an inadvertent increase in FW flow at power resulting in a high reactor vessel water level and/or neutron flux spike.
- g) Loss of Feedwater Heating - The loss of FW heating such that the reactor vessel receives cooler feedwater causing an increase in reactor power.
- h) Inadvertent Startup of the High Pressure Core Spray System - The High Pressure Core Spray (HPCS) system inadvertently starts, supplying high pressure, cold water to the reactor vessel resulting in a water level transient and possibly high neutron flux.
- i) Rod Withdrawal at Power - This transient occurs when one or more control rods are inadvertently withdrawn when the reactor is operating.

3.1.1.3 Special Initiators

Special Initiators are the failure of a support system which adversely affects a front-line system and results in a reactor SCRAM. Events in this category include the following:

- 1) Loss of Instrument Air - A loss of Instrument Air (IA) results in balance of plant (BOP) equipment and system failures. In this case, FW control would be lost and the reactor would automatically SCRAM on low reactor water level. A partial loss of IA (i.e., loss of IA to

the containment) would result in the closure of the MSIVs, reactor SCRAM, and the loss of the main condenser as a heat sink.

2. Loss of Service Water - A loss of Plant Service Water (WS) causes a loss of cooling to plant components. Various BOP equipment and system failures occur.
3. Loss of Non-Safety DC Bus - This event is defined as the loss of a single bus of non-safety DC power. A loss of FW control and automatic reactor SCRAM would occur on a high or low reactor water level.
4. Internal Flooding - A break in a system pipe or component which could cause flooding in an area that would disable important equipment. Flooding could also be caused by the failure to properly restore equipment after maintenance or tagging errors. A flood in one area could affect important equipment in another area. Although internal flooding meets the definition of a special initiator, it was not treated with an event tree like the other special initiators because it really is a composite of many scenarios. The treatment of internal flooding is discussed in section 3.3.8.

3.1.1.4 Other

These events are not initiating events but events that cause a particular challenge to safety systems subsequent to or in conjunction with another initiating event. Included in this group are the following:

1. Anticipated Transient Without SCRAM (ATWS) - The failure of the reactor to SCRAM either manually or automatically after the occurrence of another initiating event.

2. Station Blackout (SBO) - The failure of the division 1 and 2 diesel generators to start or to run after starting concurrent with a loss of off-site power.

3.1.1.5 Initiating Event Data

Initiating event frequencies are in units of average frequency per calendar year of plant operation. Methods of estimating initiating event frequencies differ among the different categories of initiators because of plant design, plant operating history and industry experience.

Some initiating events, such as anticipated transients, can be expected to occur during the life of a plant. After several years of operating experience, the initiating event frequency for these events can be derived from plant-specific data.

Some initiators are less common so that a frequency based on plant specific data would not be meaningful. The frequency of some of these initiators is assumed to relate strongly to plant-specific features so that averages based on industry data are not applicable. For example, industry experience with loss of off-site power shows a correlation between the event frequency and plant exposure to severe weather as well as grid stability. The initiating event frequency for CPS was derived from industry data and the location of the CPS site.

Other initiators, which are not expected to occur over the life of the plant, have little accumulated data to derive a frequency estimate. An example is a loss of coolant accident (LOCA) which has not occurred at a boiling water reactor (BWR). Therefore, LOCA frequencies are based on data from other industries. Interfacing system LOCA frequencies are based on plant-specific modeling of potential scenarios based on precursor events in nuclear plant industry experience.

The following is a brief discussion on the derivation of initiating event frequencies used in the CPS IPE. The initiating event frequencies for the CPS IPE are included in Table 3.1-2.

3.1.1.5.1 Loss of Coolant Accidents (LOCA) inside Containment

This category includes large, medium and small LOCAs. No plant-specific or industry data exists which directly applies to the CPS IPE. Several different industry sources such as PRAs performed at other plants were reviewed to determine the source of the initiator frequencies. The initiating event frequencies in the WASH-1400, "A Reactor Safety Study", have a factor of 10 uncertainty. Since the LOCA initiators in the other reports fell within this uncertainty range and the values from WASH-1400 were used in the Grand Gulf PRA, it was decided to also use these frequencies in the CPS IPE.

3.1.1.5.2 LOCA Outside Containment

The LOCA outside containment modeled in the CPS IPE is the interfacing system LOCA (ISLOCA). This scenario can arise only if specific combinations of component failures or human errors occur in specific plant systems. The frequency of the scenario is estimated by modeling the series of events that must occur, assessing the likelihood of each event, and using the model to estimate the expected frequency of the initiator. The methods of NUREG/CR-5124, "Interfacing Systems LOCA, Boiling Water Reactors", with additional input from WASH-1400, "Reactor Safety Study", the IDCOR BWR IPE Methodology (IPEM), EPRI pipe failure data, and the GESSAR PRA, were used to perform this analysis.

The analysis began by considering the containment penetrations to identify which lines are susceptible to ISLOCA. Lines eliminated from further consideration include high energy lines, lines with a diameter of less than one and one half inches, Control Rod

Drive (CRD) injection lines, lines connected to primary systems with a normally closed isolation valve, lines not connected to primary systems, and open ended lines that could not be overpressurized. An analysis was performed on the remaining lines to determine the ISLOCA initiating event frequency.

Table 3.1-3 identifies those lines susceptible to ISLOCA and the initiating event frequency for each.

3.1.1.5.3 Loss of Off-site Power (LOOP)

A total loss of off-site power (LCCP) has not occurred at CPS so the frequency for this initiating event was determined using the model and data in NUREG/CR-1032, "Evaluation of Station Blackout Accidents at Nuclear Power Plants". Supporting data from Nuclear Management and Resources Council (NUMARC) 87-00, "Guidelines and Technical Basis for NUMARC Initiative Addressing Station Blackout at Light Water Reactors," was also used. The frequency of LOOP is evaluated from the following four variables:

- 1) Grid-related factors
- 2) Extremely severe weather factors
- 3) Severe weather factors
- 4) Plant centered factors

Grid related off-site power events are those related to insufficient generation, excessive loads, or dynamic instability. Extremely severe weather factors are the probability of storms occurring with winds greater than 125 mph. Severe weather factors consider the probability of storms that include excessive snowfall, tornadoes, other storms with winds between 75 and 124 mph, and salt spray. Plant-centered factors for LOOP include

events such as switching errors, hardware failures, design deficiencies, and local weather induced effects such as lightning strikes.

The total LOOP initiating event frequency was derived by summing the frequency contributions from the four frequency factors discussed above.

3.1.1.5.4 Transient Initiators

Transient initiating events occur with greater frequency than other initiators and are expected to occur during the life of the plant. Plants with several years of operating history can derive valid transient initiator frequency estimates based on plant-specific data. CPS has been operating only a few years so industry data was used primarily.

The CPS IPE uses data from NUREG/CR-4550, "Analysis of Core Damage Frequency Grand Gulf, Unit 1 Internal Events". The transient initiators in this report were based on industry data compiled in NUREG/CR-3862, "Development of Transient Initiating Event Frequencies for use in Probabilistic Risk Assessments". To determine if significant deviations exist between these estimates and the limited CPS data, CPS-specific initiator frequencies were derived and compared with Grand Gulf data. In each case, the industry estimates fell within the confidence bands associated with the CPS data. Table 3.1-4 contains the results of the analysis.

As CPS accumulates more years of operating data, plant-specific estimates will be developed to replace the industry estimates when the PRA is updated.

3.1.1.5.5 Special Initiators

Included in this category are support system failures that lead to a reactor SCRAM and cause the unavailability of front-line systems. Initiator frequencies were based on plant data, if available, or quantification of a system model. Industry data for these initiators are not easily applied because support systems have different configurations, success criteria, and operating conditions at different plants.

The following is a brief discussion of the initiating event frequency for the special initiators.

Loss of Plant Service Water - The Plant Service Water (WS) system consists of three pumps which pump lake water through two strainers to cool BOP loads. Two pumps are normally running with the third in standby. The system fails if all three pumps fail. Other system failure modes include plugging of the intake travelling screens or discharge strainers. This simplified WS system model was used to determine the initiating event frequency.

The CPS estimate is lower than the estimate in the boiling water reactor (BWR) individual plant examination methodology (IPEM). The IPEM estimate is conservative and is based on an empirical estimate from a database with no loss of WS events occurring in over 400 years of plant operation. Additionally, since the design of WS systems varies from plant to plant, it is difficult to apply generic estimates to a specific plant. The Grand Gulf analysis does not include this initiating event.

Loss of a Non-Safety DC Bus - An event of this type did occur at CPS during the first year of operation. However, using one event to develop an initiator frequency would distort the event. Therefore, data from NUREG-0666, "A Probabilistic Safety Analysis of DC Power Supply Requirement for Nuclear Power Plants" was used. The values for the loss of a DC bus from a combination of hardware failures and a LOOP was combined with the loss of a DC bus due to operator and maintenance errors to arrive at an initiator frequency. Although the NUREG addresses safety-related buses, it is appropriate to use these values for the CPS IPE because the models in the NUREG are similar to the non-safety DC buses at CPS. The frequency obtained from the NUREG was increased based on the actual event that occurred at CPS.

This initiator was not included in the Grand Gulf analysis.

Loss of Instrument Air - A fault tree model was developed for the CPS Instrument Air (IA) system. This model was quantified to estimate the IA system unavailability during power operation by removing events such as LOOP which would be the result of another initiator.

The Grand Gulf analysis initiator frequency estimate was based on a simple model that assessed the probability that all the compressors in the system are unavailable. However, other failures in the system could result in a loss of IA so a frequency estimate based only on compressor failures does not accurately model the system.

3.1.2. Front-Line Event Trees

Event trees are logic diagrams which depict the success or failure of various systems or actions which may result in core damage. The initiating event frequencies together with the probabilities of the system successes and failures were evaluated to determine the overall probability of core damage.

Figure 3.1-1 through 3.1-17 are the event trees used to represent the CPS response to the transient and accident initiators identified in the previous section. The functional headings of the event trees are defined and important assumptions made in the development of the event trees are identified in this section.

A mission time of twenty-four hours is assumed for the level 1 accident sequences. Many events are resolved in much less time, but systems required to operate for long periods of time will be modeled as failing if they do not operate for the entire mission time. The basis for this assumption is that after twenty-four hours the amount of decay heat that must be removed to prevent core damage has been reduced such that a significant amount of time is available to repair critical equipment. Alternate systems could also be used at this point to remove decay heat. Additionally, after twenty-four hours, a substantial amount of resources would be available to resolve the problem which initially caused the scenario. Therefore, the probability of repair or restoration of systems which failed or were unavailable early in the event is high. Likewise, the probability that alternate systems which perform the same critical safety function could be put into service is high. A twenty-four hour mission time has been used in other similar studies which have shown that there is a negligible increase in risk when the mission time is extended beyond twenty-four hours.

3.1.2.1 Critical Safety Functions

Critical safety functions (CSFs) are defined as those conditions which, if satisfied, limit the potential for breaching (or mitigate challenges to) the fission product barriers, namely the fuel cladding, the reactor coolant pressure boundary and the containment. These barriers can be fulfilled by automatic initiation of plant systems, by passive system performance, or by operator action.

This section provides a general description of each CSF considered in the CPS IPE. The CSFs that provide the framework for the safe operation of CPS include the following:

1. Reactivity control
2. Reactor pressure vessel (RPV) pressure control
3. High pressure coolant injection
4. RPV depressurization
5. Low pressure coolant injection
6. Containment pressure control

Each CSF is described below.

Reactivity Control - During postulated accident sequences, an important safety function is to insert a sufficient amount of negative reactivity to bring the reactor subcritical. After a transient, this is normally done by automatically or manually initiating a SCRAM signal which causes the rapid insertion of control rods.

The Reactor Protection System (RPS) and Control Rod Drive (CRD) System are the systems designed to insert negative reactivity. Since both are highly reliable systems, reactivity control is not broken down further in the event trees except for anticipated transient without SCRAM (ATWS). If an automatic SCRAM is not successful, then the event is transferred to the ATWS event tree for further analysis. There are basic events for the failure to SCRAM due to a mechanical failure and the failure to SCRAM due to an electrical failure. The backup for the mechanical failure is the injection of a neutron absorber solution by the Standby Liquid Control (SLC) system. The backup for the electrical

failure is SLC and the Alternate Rod Insertion (ARI) system. The Reactor Recirculation (RR) Pump Trip (RPT) system assures that the RR pumps trip to reduce reactor power. The safety relief valves (SRVs) can be used to dump steam into the suppression pool if the main condenser is not available.

Success for reactivity control is automatic or manual insertion of all control rods to at least position 00 or insertion of all except a maximum of eight rods, each at least two cells apart.

Reactor Pressure Vessel (RPV) Pressure Control - Reactor pressure vessel (RPV) pressure control is necessary to ensure that nuclear system pressure does not increase to the point at which the integrity of the reactor coolant pressure boundary could be lost. There are a number of transients in which the main steam isolation valves (MSIVs) close and the main condenser is not available. The SRVs are then used to control RPV pressure. At least one of the sixteen SRVs must function to successfully control RPV pressure. Additionally, the SRVs must also close. Otherwise, the Reactor Core Isolation Cooling (RCIC) system does not have the steam pressure to enable it to make up the coolant inventory loss. If the SRVs do not close, analysis would transfer to the inadvertent/stuck open relief valve event tree.

Success for pressure control is that at least one of the 16 SRV's opens to prevent reactor pressure vessel overpressurization for all initiators except ATWS. For ATWS at least four SRV's must function. Any SRVs that open must also close so that RCIC is able to function.

With the MSIVs open, the Circulating Water (CW) system operating, and vacuum maintained, the turbine bypass valves may be opened to use the main condenser as a heat sink.

High Pressure Coolant Injection - The high pressure coolant injection systems provide reactor coolant makeup after a transient without depressurizing the RPV. Transients such as a turbine trip will require inventory makeup at the rate of boil off from decay heat generation.

Success for high pressure injection is operation of the Feedwater (FW) delivery system, the High Pressure Core Spray (HPCS), or RCIC system. If these systems do not function properly, it would be necessary to depressurize the RPV so that low pressure systems could provide makeup.

Credit was also taken for the Control Rod Drive (CRD) system providing high pressure make-up after a reactor SCRAM. CRD is used only after some other system has successfully functioned for some period of time so that the decay heat generation rate is reduced.

RPV Depressurization - The RPV is depressurized by manually or automatically opening SRVs so that low pressure systems can provide reactor coolant makeup. This is accomplished with the Automatic Depressurization System (ADS). One relief valve is required to function in order to successfully depressurize the reactor in time to allow low pressure systems to function preventing core damage. The relief valves are located on the Main Steam (MS) lines in the drywell and discharge to the suppression pool. In a large break loss of coolant accident (LOCA), the RPV would rapidly depressurize so the SRVs would not be required to function.

Emergency Operating Procedures (EOPs) direct the operator to manually control reactor pressurize using SRV's if needed. The EOP's also direct the operators to inhibit ADS during an ATWS or if reactor vessel water level cannot be held above the top of the active fuel. Successful manual operation of SRVs is assumed for any event in which high pressure injection is lost and low

reactor vessel water level occurs. The functioning of an SRV when reactor pressure reaches the SRV setpoint is not affected by operating the valves manually.

Low-Pressure Coolant Injection - Low pressure coolant injection is used following depressurization of the RPV below the maximum operating pressure for these systems, through normal cooldown, actuation of ADS or a large break LOCA. The low pressure injection systems can provide adequate core cooling once the RPV is depressurized.

The systems used for low pressure coolant injection include the following:

- 1) The Residual Heat Removal (RHR) system operating in the low pressure coolant injection (LPCI) mode.
- 2) Low Pressure Core Spray (LPCS)
- 3) Condensate Booster (CB) pumps in conjunction with the Condensate (CD) pumps
- 4) CD Pumps without CB
- 5) The diesel driven fire pumps in conjunction with the Plant Service Water, (WS) Shutdown Service Water (SX) and RHR system piping and valves.

Each system can inject water into the vessel once reactor pressure is reduced to the operating range of that system. The fire pumps require several hours to align before injection into the RPV can begin. The fire pumps as an injection source are not modeled as a front-line system but are used as a recovery upon delayed failure of other systems.

Success for low pressure injection is successful operation of LPCS or any one of the three low pressure Coolant Injection (LPCI) train: or CD/CB.

Containment Pressure Control- Containment heat removal is required to maintain containment pressure below pressure limits and ensure that containment integrity is maintained. Venting the containment is an alternate method of heat removal/pressure control.

Decay heat is normally removed through the main condenser. This requires that the MSIVs remain open and the MS, CD, CB, FW, Condenser Air Removal (CA), and Circulating Water (CW) Systems be in service. If the main condenser is not available, the RHR system is used to remove decay heat.

There are three operating modes of the RHR system for removing decay heat. They are shutdown cooling, suppression pool cooling, and containment spray. Once the RPV has been depressurized, the RHR system can be placed in shutdown cooling to remove heat from the reactor core. If the SRVs were used to depressurize the reactor or if the RCIC system were in operation, then at least one loop of the RHR system is aligned in the suppression pool cooling mode to remove heat from containment. If there is a large break LOCA and pressure is increasing inside containment, the RHR system can be aligned to the containment spray mode. Suction is taken from the suppression pool and discharged through the heat exchangers to spray headers in the containment dome. Successful decay heat removal depends on successful operation of either the Plant Service Water (WS) or Shutdown Service Water (SX) systems.

Only the suppression pool cooling mode of RHR is modeled in the level 1 PRA and only as support for successful RCIC operation. The shutdown cooling mode of RHR is not included in the model because it is not needed to prevent core damage during the 24

hour mission time of the IPE. The containment spray function is modeled in the containment analysis because its primary function is to maintain containment integrity.

Success for containment heat removal is successful operation of one train of RHR in the suppression pool cooling mode.

In the event that the main condenser and the RHR system are not available to remove heat or non-condensable gas production has resulted in increasing containment pressure, the containment must be vented to maintain integrity. There are six vent paths available but only the largest three are modeled. The other three do not have sufficient capacity, by themselves, to vent containment. The three modeled paths are 1) The RHR system through the Fuel Pool Cooling and Cleanup (FC) system and through the spent fuel pool, 2) The FC system through the spent fuel pool, 3) Through a hole cut in the exterior duct work in the Containment Continuous Purge systems.

3.1.2.2 Level 1 Event Trees

For each initiating event, including Anticipated Transient Without SCRAM (ATWS) and station blackout (SBO) identified in section 3.1.1 but excluding internal flooding, an event tree was constructed. The level 1 event trees are described below:

Anticipated Transients and Special Initiators - The form of the event tree for each of these initiating events is similar. Three of these events which have identical structure and the corresponding figures are as follows:

- * Transient without Isolation (Figure 3.1-1)
- * Loss of Feedwater (Figure 3.1-2)
- * Loss of a non-Safety DC Bus (Figure 3.1-3)

Once the initiating event has occurred, the reactor automatically SCRAMs. If an automatic SCRAM does not occur the sequence transfers to the ATWS event tree. After a successful SCRAM, the event tree evaluates the availability of the main condenser as a heat sink. If the main condenser is available, then the event tree transfers to RCIC injection, high pressure injection, depressurization of the reactor and finally low pressure injection. If the main condenser is not available, the event tree transfers to pressure control using the SRVs. After successful operation of the SRVs (success includes both opening and closing), the event tree proceeds as above except that suppression pool cooling must be available to support successful RCIC operation. If no SRVs open, then the sequence transfers to the large break loss of coolant accident (LOCA) event tree because some component in the primary system will fail resulting in a loss of reactor coolant with depressurization. If a SRV opens but fails to close, then the sequence transfers to the inadvertent/stuck open relief valve event tree.

There is another group of identically structured event trees in this category. These event trees and the corresponding figure numbers are as follows:

- * Transient with Isolation (Figure 3.1-4)
- * Loss of Instrument Air (Figure 3.1-5)
- * Loss of Service Water (Figure 3.1-6)

These event trees are similar to the other event trees in this group except that the availability of the main condenser sequence is not included. In these events, the main steam isolation valves (MSIVs) close, isolating the reactor from the main condenser. Pressure is controlled with the SRVs.

Loss of Off-site Power (LOOP) - Since on-site and off-site power sources have a significant effect on the front-line & support systems, the loss of off-site power (LOOP) event tree is significantly different from other event trees (Figure 3.1-7).

Once off-site power is lost, the reactor automatically SCRAMS. If an automatic SCRAM does not occur, then the sequence transfers to the ATWS event tree. After a successful SCRAM, the event tree models reactor pressure control. A branch is added which evaluates the probability that off-site power is recovered within one-half hour. If off-site power is recovered within one-half hour then the sequence transfers to the transient with isolation event tree. Industry experience shows that many LOOP events are short duration and analysis shows that core damage can be averted if injection can be started in less than a half-hour. The status of the division 1 and 2 diesel generators is then evaluated. If neither diesel generator is available then the sequence transfers to the station blackout (SBO) event tree for further analysis. If either diesel generator is available, then the LOOP event tree continues through high pressure injection with the RCIC system, with suppression pool cooling, HPCS, manual depressurization, and finally low pressure injection. System availabilities in these event trees differ depending on whether one or two diesel generators are available.

The main condenser and FW delivery systems will be lost early in the event. Once off-site power is recovered, the probability of system unavailability may be different from values used earlier because operators must take actions such as starting a pump to recover lost systems. These actions are dependent on location of the equipment and plant conditions which would affect system unavailability. While CPS recognized different operator dependencies, they could not be fully incorporated into the models.

Station Blackout (SBO) - The event tree is entered from the LOOP event tree after both the division 1 and 2 diesel generators fail to start or fail to run (Figure 3.1-8). The event tree evaluates the success of HPCS providing makeup. HPCS is dependant on the

division 3 diesel generator which may be available under SBO conditions. If HPCS fails, then RCIC is evaluated. RCIC depends on only DC power in the short term. Recovery of off-site power and the division 1 or 2 diesel generator is evaluated next. After recovery of off-site power, the event tree evaluates core cooling maintenance using FW and suppression pool cooling. If these are not successful, then the reactor is manually depressurized and core cooling is maintained with low pressure injection systems.

If off-site power is not recovered but a diesel generator is, then suppression pool cooling is placed in service. This is to support operation of RCIC. The event trees proceed as above except that FW is not available. FW is not supported by the diesel generators.

Loss of Coolant Accidents (LOCAs) - The event trees for LOCA initiating events vary depending on the size of the pipe break. All five LOCA event trees transfer to the ATWS event tree if an automatic SCRAM is not successful. A description of the five event trees is as follows:

1. Small Break LOCA - A small break LOCA does not depressurize the reactor to the point at which low pressure systems can provide makeup (Figure 3.1-9). High pressure injection systems initially provide makeup. If FW fails, then RCIC provides makeup with suppression pool cooling in operation. If RCIC fails, then HPCS provides makeup. If HPCS fails, then the reactor must be manually depressurized before low pressure injection systems can supply makeup.
2. Medium Break LOCA - A medium break LOCA also does not depressurize the reactor to the point at which low pressure injection systems can provide makeup (Figure 3.1-10). Additionally, RCIC does not have sufficient capacity to maintain coverage of the core. FW is not available because

makeup to the condenser maybe insufficient. Therefore, the medium break LOCA is similar to the small break LOCA event tree except FW, RCIC and suppression pool cooling are not included.

3. Large Break LOCA - A large break LOCA depressurizes the reactor to the point which low pressure injection systems can provide makeup (Figure 3.1-11). HPCS can also supply makeup. The large break LOCA is similar to the medium break LOCA except that manual depressurization of the reactor is not required.
4. Interfacing System LOCA - An interfacing system LOCA does not depressurize the reactor to the point at which low pressure injection systems can provide makeup (Figure 3.1-12). RCIC capacity is insufficient to provide makeup. The interfacing system LOCA event tree is similar to the small break LOCA event tree except that RCIC and suppression pool cooling are not included.
5. Inadvertent/Stuck Open Relief Valve (IORV) - An inadvertent/stuck open relief valve (IORV) results in uncontrolled steam flow to the suppression pool depressurizing the reactor. RCIC capacity is insufficient to provide make up (Figure 3.1-13). FW makeup is evaluated first. If FW is not successful, then HPCS and finally low pressure injection systems are used to provide makeup. There is no need to depressurize before placing low pressure injection systems in service since only one SRV is needed to depressurize the reactor prior to placing these systems in service.

Anticipated Transients without SCRAM (ATWS) - All of the event trees except station black out transfer to the ATWS event trees on a failure to SCRAM (Figures 3.1-14 through 3.1-17). The frequency of these initiators when coupled with the failure to

insert control rods, results in initiators with a very low frequency of occurrence. However, ATWS could result in a challenge to containment in addition to the demands on the core cooling systems.

The ATWS tree starts with a manual SCRAM or Alternate Rod Insertion (ARI). If these actions are successful then the event proceeds as a normal cooldown. If the reactor is not shutdown, the event tree proceeds to reactor pressure control using the safety relief valves (SRVs). If the SRVs fail to open then the event proceeds as an ATWS with a large break loss of coolant accident (LOCA). The event tree proceeds to power control even if SRV operation is not successful (open/close). Both branches of this event tree from this point are identical.

The first event under power control is Reactor Recirculation (RR) pump trip. This action will reduce reactor power but not bring the reactor subcritical. The next event is injection of a neutron absorber with the Standby Liquid Control (SLC) system. If SLC is successful, the sequence continues to inhibiting the Automatic Depressurization System (ADS). If successful, the sequence continues on sheet B on a path similar to the transient without isolation event tree (Figure 3.1-15), except that the pressure control questions have already been evaluated and RCIC is not included. If ADS is not inhibited, the sequence continues on sheet C on a path similar to a large break LOCA event tree (Figure 3.1-16).

If both trains of SLC are not successful, then one train of SLC is sufficient to shut down the reactor. However in this case, the operator has less time to start SLC in order to prevent containment failure. The sequence then proceeds as above through inhibiting ADS to shutdown. If SLC is not successful, then the event tree proceeds to the manual insertion of control rods. If successful, the event tree proceeds to a sequence similar to a large break LOCA. If not successful, the sequence proceeds to

shear+ D (Figure 3.1-17). Reactor power is reduced by lowering level in the reactor. The sequence then proceeds similar to a transient without isolation sequence without pressure control using SRVs or RCIC. However whether lowering reactor vessel level is successful or not, core damage is assumed to result unless the main condenser and feedwater system are available. The other branches on this sheet were retained for evaluation of potential impact on containment response.

3.1.2.3 Assumptions

Below are a number of assumptions used in developing the event tree success criteria. Assumptions that apply to specific event trees are included with the specific event tree to which they apply.

1. Low Pressure Core Spray (LPCS), High Pressure Core Spray (HPCS), and Residual Heat Removal (RHR) Pumps (in the low pressure coolant injection (LPCI) mode) do not lose suction after loss of containment heat removal or containment depressurization following containment venting or containment failure unless the failure is in the suppression pool. If the suppression pool were at saturation conditions, analysis (USAR 6.3.1.1.3) shows that sufficient net positive suction head remains available.
2. Loss of the steam suppression system (i.e., bypassing the suppression pool) is postulated to occur only after drywell temperature reaches 700°F because of potential penetration failure. This temperature occurs only after core damage. Loss of steam suppression could also be postulated to occur either by bypassing the suppression pool or by a loss of pool inventory. Bypass of the drywell at lower temperatures is not considered feasible because two vacuum breakers in series which are used to vent into the drywell would have to fail. Loss of suppression pool inventory, such that the

weir vents become uncovered, is only expected to occur if containment pressure reaches 93.75 psig. Failure of Emergency Core Cooling System (ECCS) suction piping which penetrates containment below the suppression pool water level is not considered credible because this piping is exposed to low pressure conditions and is seismically qualified. The treatment of steam suppression capability is consistent with the assumption made for Grand Gulf in NUREG/CR-4500.

3. The Reactor Core Isolation Cooling (RCIC) system is assumed to fail when suppression pool temperature reaches 155°F because oil temperature for the RCIC pump must be maintained below 175°F. This requirement is contained in the RCIC operating procedures and discussed in the vendor manual. The difference in temperatures is to account for inefficiencies in the lube oil cooler heat exchanger. Net positive suction head and turbine discharge back pressure are also affected at higher temperatures. Therefore the RCIC system is assumed to fail after some period of operation if suppression pool cooling is unavailable.
4. Upper pool dump is not required for maintaining adequate net positive suction head for the Emergency Core Cooling System (ECCS) pumps in the event of various loss of coolant accidents (LOCAs). A conservative calculation was performed to determine the minimum suppression pool inventory following a LOCA. This calculation assumed that the drywell volume to the top of the weir wall was completely filled with water from the suppression pool following a LOCA. Additionally, the suppression pool inventory was assumed to be further reduced by ECCS System operation to restore reactor vessel inventory. This calculation proved that the suppression pool inventory is sufficient to provide adequate NPSH to all ECCS pumps and maintain adequate weir vent coverage.

5. Core damage is assumed to be averted if the core is continuously covered to at least two-thirds the length of the active fuel. It is also assumed that core damage is averted if the duration that water level is below this limit is less than four minutes. This is based on conservative calculations assuming heatup of an uncovered core with no spray or steam cooling for a decay heat level typical of conditions immediately after reactor trip. Calculations predict a small amount of cladding damage (<10%) under these conditions. For some cases in which the above criteria could not be met, Modular Accident Analysis Program (MAAP) simulations were used to determine if core damage occurred, and the extent of the damage.

6. The amount of water required to remove decay heat two minutes after shutdown is 597.9 gallons per minute (gpm). After 102 minutes, 200 gpm are required, and after 24.5 hours 100 gpm are required based on a simplified decay heat calculation method. These flow rates were used to establish the systems that could be used to maintain reactor inventory under different scenarios. Subsequent MAAP simulations indicate that Control Rod Drive (CRD) with one pump running (140 gpm @ 1000 psi) is adequate after one hour to avert core damage, assuming reactor vessel level started at level 8.

7. Each SRV can relieve 15,086 pounds of steam per minute at 1136 psig. 1820 gallons per minute (gpm) of makeup is required to maintain reactor inventory under these conditions. Calculations were performed to determine the number of functioning SRVs necessary to reduce reactor

pressure. One SRV is adequate to depressurize the reactor sufficiently to allow low pressure systems (LPCS, LPCI, Condensate (CD) with Condensate Booster (CB)) to provide adequate make-up to the reactor in time to prevent core damage.

8. The Cycled Condensate (CY) system can provide 951 gpm to the main condenser if there is no main condenser vacuum. 1683 gpm can be provided if main condenser vacuum is present. For events in which make-up to the main condenser, from the main steam or CY systems, is at least as great as the flow needed to the reactor, the Feedwater (FW) system is modeled into the sequence.
9. In general, the FW system is dependent upon operation of the CD and CB systems to maintain adequate net positive suction head at the FW pumps. CD and the CD/CB combination can supply water to the reactor if the reactor is depressurized and if a flow path through the CD, CB and FW systems is available. With one CD pump running, up to 6000 gpm can be provided to the reactor at 60 psig reactor pressure. With one CD and one CB pump running, up to 9000 gpm can be provided to the reactor at 300 psig reactor pressure.
10. Shutdown Service Water (SX) can provide up to 1000 gpm to the reactor through the RHR system when the reactor pressure is below 50 psig. Achieving this flow rate would require the isolation of all other heat loads except diesel generator cooling and the control room heating, ventilating and air conditioning (HVAC) heat exchangers. This requirement for heat load isolation is not presently incorporated in CPS procedures so SX flow to the reactor was not modeled in the IPE.

11. The Control Rod Drive (CRD) and the Standby Liquid Control (SLC) systems can deliver water to the vessel at normal operating pressures. These systems are potential sources of high pressure coolant injection. The CRD system's flow rate to the core, following a reactor SCRAM, is about 140 gpm with one pump running and reactor pressure at 1000 psig, and about 150 gpm with two pumps running. There is not a significant increase in flow with two pumps in operation because of high flow resistance in the lines. The SLC pumps can each provide approximately 42 gpm. These systems together are capable of maintaining coolant inventory one hour after a reactor trip.

12. Although the ECCS logic automatically initiates the Automatic Depressurization System (ADS) timer on high drywell pressure or low reactor water level conditions, emergency operating procedures (EOPs) direct the operator to inhibit ADS during an anticipated transient without SCRAM (ATWS) or a transient in which the reactor vessel level cannot be maintained greater than -162.5 inches (top of active fuel). If depressurization is subsequently required, an additional operator action is needed to initiate ADS or to open the required number of SRVs. The assessment of the depressurization function in the CPS event trees assumes that the operator follows procedures and successfully inhibits ADS.

13. The Fire Protection (FP) system can provide adequate flow to the reactor vessel (e.g., 600 gpm at approximately 73 psig) to provide core cooling. The flow path is through Plant Service Water (WS) to SX and RHR. This alignment requires several hours to accomplish. Therefore, FP was only considered as a core cooling success path for sequences in which several hours of core cooling have been provided by another system.

14. In some event trees, headings representing individual systems or groups of systems are arranged in an order that is not precisely consistent with the expected chronological order of initiation. This is done to simplify the quantification and is permissible if the reordering does not affect the success criteria for systems considered later in the event tree, i.e., no system dependencies found in the event tree logic.

For example, in the transient without isolation event tree, the success or failure of the RCIC system is considered before the success or failure of other injection sources. This is even before FW which would normally be the first system operators would consider. The order of these systems in the event tree does not affect the core damage sequences and the success or failure of RCIC does not affect the other core cooling systems (Motor Driven FW pump, HPCS, LPCI, LPCS, etc.). However if core cooling systems were considered ahead of reactor SCRAM or pressure control systems (main condenser, SRVs), this would create problems in correctly evaluating core damage sequences, as the success criteria for core cooling is strongly affected by the success or failure of the SCRAM and pressure control functions.

3.1.3 Special Event Trees

Special attention was applied to the anticipated transient without scram (ATWS) and to the station blackout (SBO) event trees. The ATWS event tree contains more detail than most event trees because the emergency operating procedures (EOP) require a significant amount of operator action. These events include the various methods to control reactor power such as initiation of Standby Liquid Control (SLC), manually inserting control rods, reactor water level control, and inhibiting the Automatic

Depressurization System (ADS). ATWS events could result in a challenge to containment in addition to the demands on core cooling.

The SBO event tree evaluates various recoveries of off-site and onsite power sources before evaluating status of core cooling. This is because analysis has shown that if an injection source can be restored in a half hour, core damage will be averted. Additionally, industry experience has shown that loss of off-site power (LOOP) events are usually of short duration.

3.1.4 Support System Event Trees

Fault tree linking was used to model the support systems and their interdependencies for the CPS PRA. Fault trees for the support systems were developed concurrently with the front-line systems. The support system fault trees were then linked with the front-line systems. In this way, support systems are explicitly modeled with front-line system fault trees, and no support system event trees are required. Table 3.1-5 outlines which CPS systems are considered front-line and which are considered support. Fault trees and their quantification are discussed in subsequent sections of this report.

3.1.5 Sequence Grouping and Back-End Interfaces

The accident sequences leading to core damage are categorized into classes and subclasses. Grouping or binning of similar core damage sequences into classes is performed based on the following criteria:

- Containment integrity
- Primary system integrity

- Relative timing of core damage.
- Primary system pressure
- Failure of critical functions leading to core damage.

The core damage sequence bins used in the Clinton Power Station (CPS) Individual Plant Examination (IPE) follow the guidance contained in Nuclear Management & Resources Council (NUMARC) 91-04, "Severe Accident Issue Closure Guidelines". The core damage bins are called accident classes and serve as input to the Level 2 Containment Analysis. Table 3.1-6 illustrates the grouping process.

The five classes are further divided into subclasses based upon the unavailability of key functions. Table 3.1-7 provides a description of those sub-classes.

In summary, the event tree sequence end states are either a safe shutdown condition or one in which core damage occurs. The core damage sequences are binned to provide a discrete representation of the spectrum of possible core damage states. The core damage classes provide the entry conditions to the containment event trees discussed in Chapter 4.

TABLE 3.1-1

INITIATING EVENT GROUPING GUIDELINES

The following guidelines were used to group initiating events for detailed evaluation. If any of the following criteria is met, the initiating event is put into a new group.

1. Plant response following the event cannot be adequately characterized by an event tree for any other initiating event.
2. Mitigating system requirements following the initiating event are unique.
3. The event directly degrades the operation of important mitigating systems (front-line or support) in a manner that cannot be adequately addressed by another initiating event.
4. The event directly degrades the operation of important mitigating systems in a manner that is significantly different than for other initiating events.
5. Operator response to the initiating event is unique due to any of the following reasons: (1) plant response following the initiating event requires unique operator actions; (2) the initiating event disables instrumentation which is required for successful operator action; or (3) the initiating event changes the likelihood of successful operator performance by some other mechanism.
6. The event alters the physical environment in which mitigating systems or operators must function in a manner that cannot be adequately addressed by another initiating event.
7. The event affects the consequences of core damage in a manner that cannot be adequately addressed by an event tree for another initiating event. (Specifically, the amount of radioactive material released beyond the primary system pressure boundary, either on-site or off-site, is significantly different; the timing of the release is significantly different; the systems available to prevent or mitigate a release are significantly different, etc.)

TABLE 3.1-2

CPS INITIATING EVENTS
WITH INITIATING EVENT FREQUENCIES AND
EVENT TREE DESIGNATORS

<u>Initiating Event</u>	<u>Initiating Event Frequency *</u>
1. <u>Loss of Coolant Accidents (LOCA)</u>	
S2 - Small Break LOCA	1.00E-03
S1 - Medium Break LOCA	3.00E-04
A - Large Break LOCA	1.00E-04
T9 - Interfacing System LOCA	5.00E-06
T4 - Inadvertent/Stuck Open Safety Relief Valve (IORV)	1.00E-01
2. <u>Transients</u>	
TP - Loss of Offsite Power (includes transients due to both external sources and onsite failures, but not station blackout)	8.4E-02
T5 - Loss of Feedwater	0.6
* Total Loss of Feedwater	
* Low Feedwater Flow	
* Partial Loss of Feedwater	
T3 - Transient With Isolation	1.7
* Main Steam Isolation Valve (MSIV) Closure (all MSIVs close)	
* Inadvertent Closure of One MSIV	
* Partial MSIV Closure	
* Loss of Condenser Vacuum	
* Turbine Trip with Turbine Bypass Valve Failure (including generator load rejection and intentional turbine trip)	
* Turbine Bypass Valves Fails Open	
* Turbine Pressure Regulator Failure (open and closed)	

* Per Reactor Year

TABLE 3.1-2 (cont.)

CPS INITIATING EVENTS WITH INITIATING EVENT FREQUENCIES2. Transients (Cont'd)

T2 - Transient Without Isolation 4.7

- * Manual Shutdown
- * Turbine Trip with Turbine Bypass Valves Open (including generator load rejection and intentional turbine trip)
- * Reactor Recirculation Control Failure (increasing and decreasing flow)
- * Trip of Both Reactor Recirculation Pumps
- * Abnormal Startup of Idle Reactor Recirculation Pump
- * Feedwater Flow Increase
- * Loss of Feedwater Heating
- * Inadvertent Startup of the High Pressure Core Spray System
- * Control Rod Withdrawal at Power

3. Special Initiators

IA - Loss of Instrument Air 4.32E-03

SW - Loss of Service Water 1.75E-03

DC - Loss of Non-Safety DC Bus 1.39E-02

4. Other

ATW - Anticipated Transient Without Scram (ATWS) *

TL - Station Blackout (loss of off-site power with the simultaneous failure of the division 1 and 2 diesel generators)

- * There is not an initiating event for station blackout or ATWS. The station blackout event tree is entered from the loss of all off-site power event tree in the event that division I and II diesel generators do not function. The ATWS tree is entered in the case in which any other transient occurs and a SCRAM is not successful.

TABLE 3.1-3

CLINTON IPE INTERFACING SYSTEMS LOCA FREQUENCIES

<u>System (Number of Lines)</u>	<u>Frequency per Line (per year)</u>	<u>Total Frequency (per year)</u>
LPCI Injection Lines (3)	4.9E-8	1.47E-7
LPCS Injection Line (1)	2.86E-8	2.86E-8
Shutdown Cooling Suction Line (1)	2.54E-6	2.54E-6
RPV Head Spray Line (1)		4.94E-11
RCIC Pump Suction	4.53E-11	
LPCI Loop B	4.11E-12	
HPCS Line (1)	1.98E-9	1.98E-9
Feedwater Lines (2)	--	2.28E-6
Shutdown Cooling Return Lines (2)	3.74E-11	3.31E-11

TOTAL ISLOCA FREQUENCY		5.00E-6

TABLE 3.1-4

COMPARISON OF INDUSTRY AND CLINTON PLANT SPECIFIC
TRANSIENT FREQUENCY DATA

<u>TRANSIENT CATEGORY</u>	<u>NUREG/CR-4550 ESTIMATE (per yr.)¹</u>	<u>NUMBER OF EVENTS IN CLINTON DATA</u>	<u>PLANT SPECIFIC ESTIMATE (per yr.)¹</u>	<u>90% CONFIDENCE INTERVAL²</u>
Transient Without Isolation	4.7	11	3.8	2.1, 6.3
Transient With Isolation	1.7	5	1.7	0.68, 3.6
Loss of Feedwater	0.6	1	0.34	0.018, 1.6
Inadvertent Open Relief Valve	0.1	0	0.17 ³	-----, 1.0

Notes:

1. All frequencies are per reactor year. Clinton plant data covers 11/24/87 through 7/12/90 (2.89 years).
2. Confidence interval bounds are lower and upper 95% confidence limits. No lower limit is calculable for zero events in the data.
3. Clinton plant-specific inadvertent open relief valve frequency estimate, based on zero events, was derived by assuming 0.5 "events" have occurred (to avoid a trivial solution), and calculating the frequency estimate with this as the numerator.

TABLE 3.1-5

CPS FRONT-LINE AND CRITICAL SUPPORT SYSTEMSFront-Line Systems

1. Reactor Protection System (RP)
2. Main Feedwater System (FW)
3. High Pressure Core Spray System (HP)
4. Reactor Core Isolation Cooling System (RI)
5. Low Pressure Core Spray System (LP)
6. Residual Heat Removal system (RHR) including Low Pressure Coolant Injection (LPCI), Containment Spray, Suppression Pool Cooling, and Shutdown Cooling.
7. Automatic Depressurization System (ADS)
8. Condensate System (CD)
9. Condensate Booster (CB)
10. Standby Liquid Control System (SLC)

Critical Support Systems

1. Auxiliary AC Power System/Onsite, Offsite, Switchyard (AP/SY)
2. Emergency AC Power System (DG)
3. DC Power System (DC)
4. Shutdown Service Water System (SX)
5. Plant Service Water System (WS)
6. Service/Instrument Air System (SA/IA)
7. Component Cooling Water System (CC)
8. Turbine Building Closed Cooling Water System (WT)
9. Essential Switchgear Heat Removal System (VX)
10. Fire Protection System (FP)
11. ECCS Equipment Room HVAC (VY)

Table 3.1-6
ACCIDENT SEQUENCE CLASSES

ACCIDENT CLASS DESIGNATOR	DESCRIPTION	PHYSICAL BASIS FOR CLASSIFICATION	REPRESENTATIVE ACCIDENT SEQUENCES
Class I	Transients Involving Loss of Coolant Makeup	Fuel will melt rapidly if cooling systems are not recovered; containment is intact at low pressure initially and at core melt; release pathway early in the event is from the vessel to the suppression pool through SRVs	Transients involving loss of high pressure inventory makeup and failure to depressurize RPV; transients involving loss of both high and low pressure injection.
Class II	Transients Involving Loss of Containment Heat Removal	Fuel will melt relatively slowly due to lower decay heat level if cooling systems are not recovered; containment is breached prior to core melt; release pathway is from the vessel to the suppression pool through SRVs during initial stages of core damage	Not applicable at CPS.
Class III	LOCAs	Fuel will melt rapidly if cooling systems are not recovered; containment intact at core melt, but initially at high internal pressure; involves a release from the vessel to the drywell	Large and medium LOCAs with insufficient high or low pressure coolant makeup; small and medium LOCAs with failure of the SRVs to actuate and loss of high pressure inventory makeup; RPV failure with insufficient coolant makeup
Class IV	ATWS	Fuel will melt rapidly if cooling systems are not recovered; containment fails prior to core melt due to overpressure; initial release pathway is from the vessel to the suppression pool through SRVs	Transients involving loss of SCRAM function and backup reactivity control

Table 3.1-6
ACCIDENT SEQUENCE CLASSES

ACCIDENT CLASS DESIGNATOR	DESCRIPTION	PHYSICAL BASIS FOR CLASSIFICATION	REPRESENTATIVE ACCIDENT SEQUENCES
Class V	Unisolated LOCAs Outside Containment	Fuel will melt rapidly if cooling systems are not recovered; containment failed from initiation of accident due to containment bypass involves a release pathway from the vessel which bypasses the containment	LOCAs outside containment with insufficient coolant makeup; interfacing system LOCAs with insufficient coolant makeup

Table 3.1-7

ACCIDENT SEQUENCE SUBCLASSES

ACCIDENT SEQUENCE CLASS	ACCIDENT SEQUENCE SUBCLASS	DEFINITION
CLASS I	A	Accident Sequences Involving Loss of Inventory Makeup in which Reactor Pressure Remains high
	B	Accident Sequences Involving a Loss of AC Power and Loss of Coolant Inventory Makeup
	C	Accident Sequences Involving a Failure to Scram (ATWS) with a Coincident Loss of All Inventory Makeup
	D	Accident Sequences Involving a Loss of Coolant Inventory Makeup in which Reactor Pressure has been Successfully Reduced to Low pressure.
CLASS II	-	Accident Sequences Involving a Loss of Containment Heat Removal
CLASS III	A	Accident Sequences Initiated by Reactor Pressure Vessel Rupture where Containment Integrity is not Breached in the Initial Phases of the Accident
	B	Accident Sequences Initiated or Resulting in Small or Medium LOCAs for which the Reactor Pressure Vessel is not Depressurized
	C	Accident Sequences Initiated or Resulting in Medium or Large LOCAs for which the Reactor Pressure Vessel is Depressurized and All Low Pressure Injection Fails

Table 3.1-7

ACCIDENT SEQUENCE SUBCLASSES

ACCIDENT SEQUENCE CLASS	ACCIDENT SEQUENCE SUBCLASS	DEFINITION
CLASS III (Cont.)		
	D	Accident Sequences which are Initiated by a LOCA or Reactor Pressure Vessel Failure and for which the Vapor Suppression System has failed, Challenging the Containment Integrity
CLASS IV	-	Accident Sequences Involving Failure to Scram and Failure to Inject Boron Leading to a High Pressure challenge to the Containment Resulting from Power Generation into the Containment.
CLASS V	-	Unisolated LOCA Outside Containment

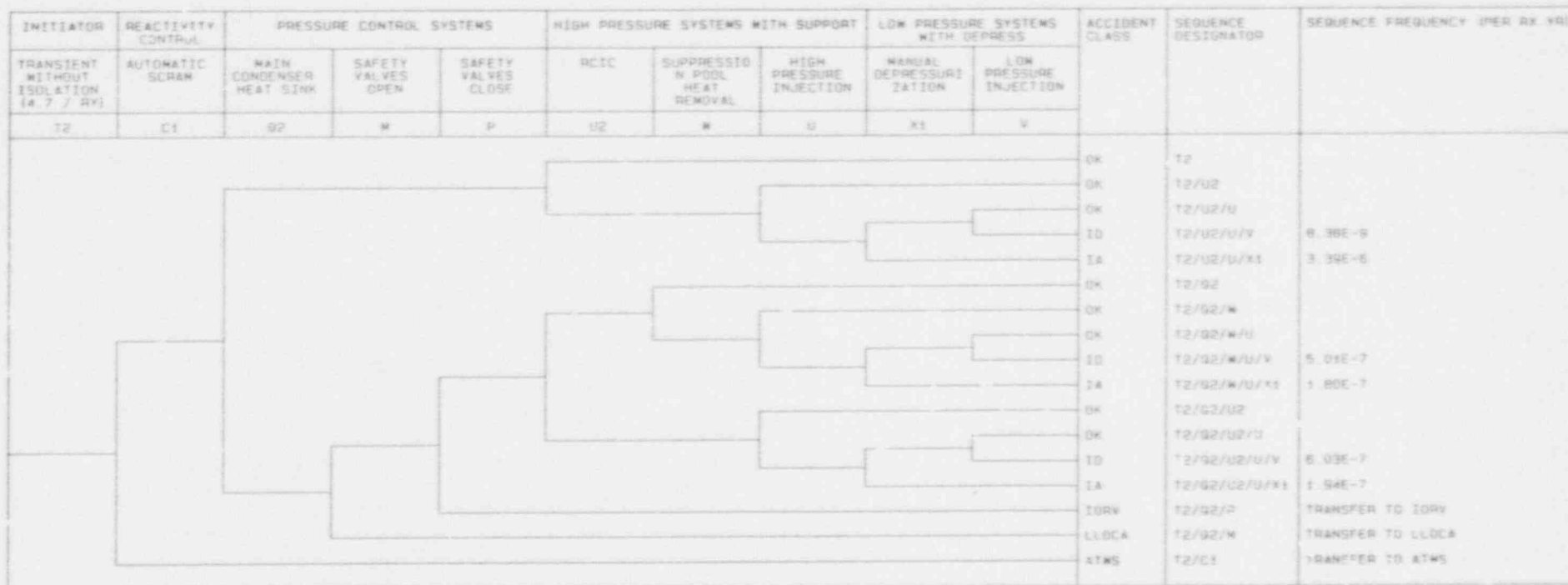

Figure 3.1-1

Transient Without Isolation
Event Tree



Figure 3.1-2

Loss of Feedwater
Event Tree

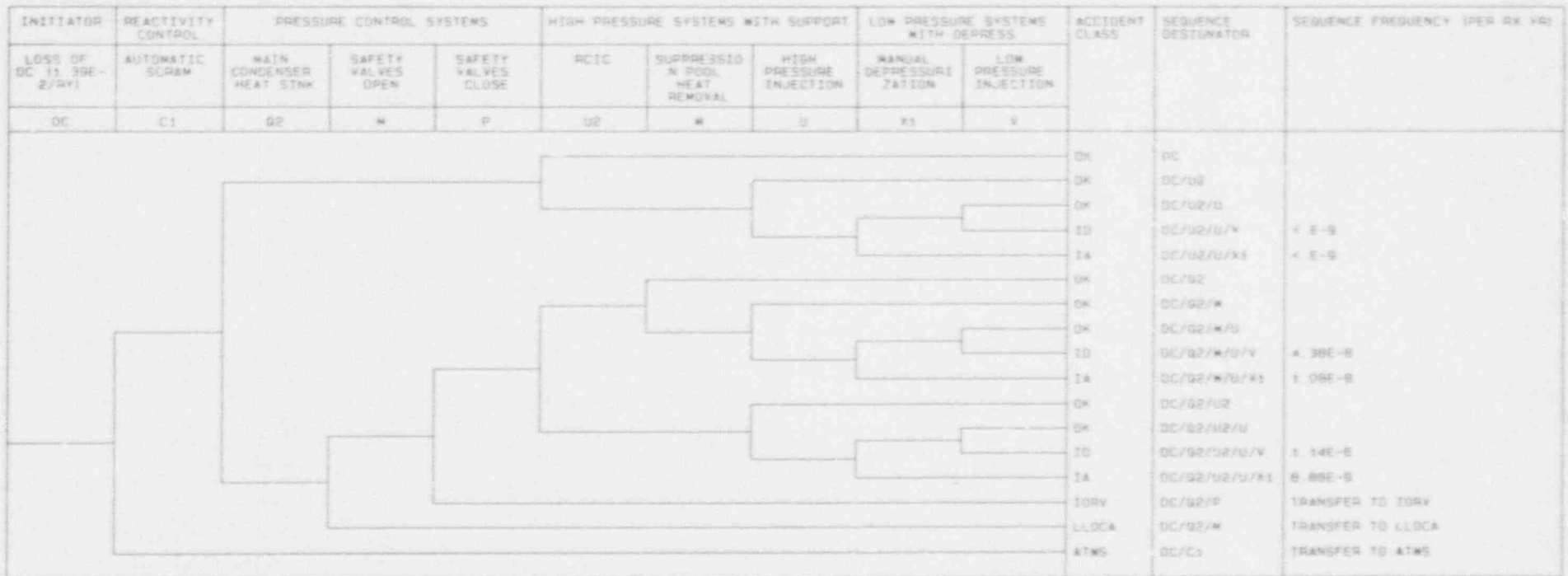

Figure 3.1-3

Loss of Non-Safety DC
Bus Event Tree

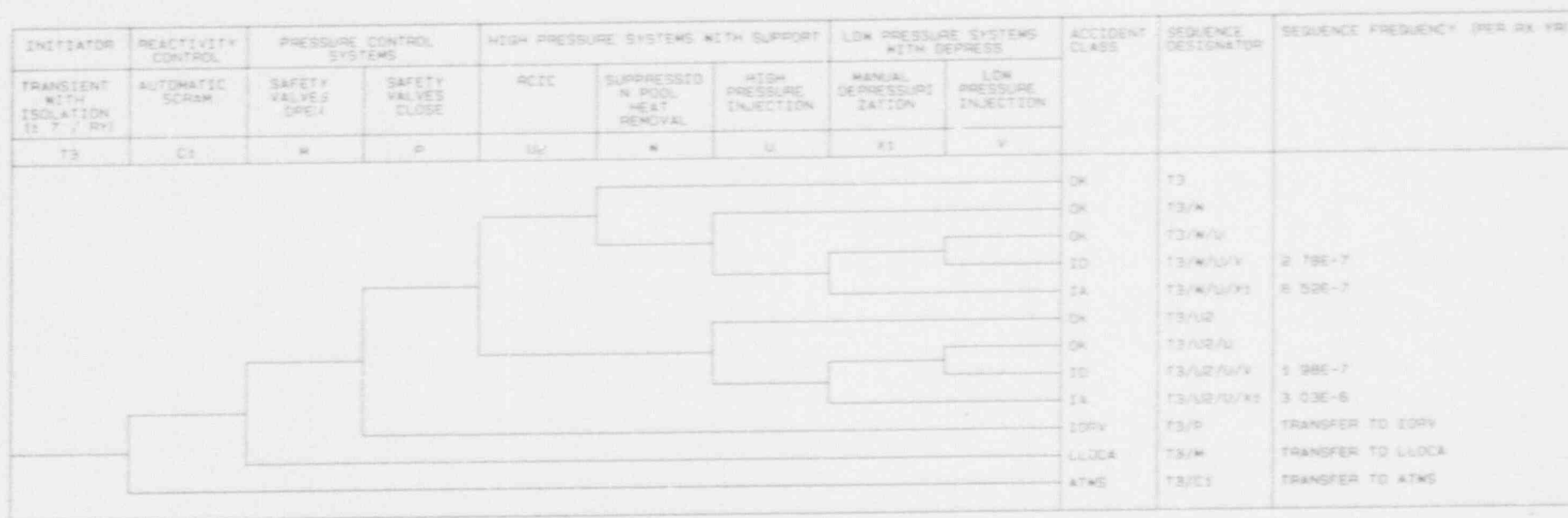

Figure 3.1-4

Transient With Isolation
Event Tree

INITIATOR	REACTIVITY CONTROL	PRESSURE CONTROL SYSTEMS		HIGH PRESSURE SYSTEMS WITH SUPPORT			LOW PRESSURE SYSTEMS WITH DEPRESS		ACCIDENT CLASSES	SEQUENCE DESIGNATOR	SEQUENCE FREQUENCY (PER RX YR)	
		SAFETY VALVES OPEN	SAFETY VALVES CLOSE	HCIC	SUPPRESSED N POOL HEAT REMOVAL	HIGH PRESSURE INJECTION	MANUAL DEPRESSURIZATION	LOW PRESSURE INJECTION				
LOSS OF INSTRUMENT AIR (4.3E-3/RY)	AUTOMATIC SCRAM											
IA	C1	M	P	UR	M	U	X1	Y				
										OK	IA	
										OK	IA/W	
										OK	IA/W/U	
										CC	IA/W/U/Y	> 0.3E-8
										IA	IA/W/U/X1	< E-9
										OK	IA/GE	
										OK	IA/UR/U	
										IC	IA/UR/U/Y	< E-9
										IA	IA/UR/U/X1	< E-9
										IDRV	IA/P	TRANSFER TO IDRV
LLOCA	IA/M	TRANSFER TO LLOCA										
ATWS	IA/C1	TRANSFER TO ATWS										

Figure 3.1-5

Loss of Instrument Air
Event Tree

INITIATOR	REACTIVITY CONTROL	PRESSURE CONTROL SYSTEMS		HIGH PRESSURE SYSTEMS WITH SUPPORT			LOW PRESSURE SYSTEMS WITH DEPRESS		ACCIDENT CLASS	SEQUENCE DESIGNATOR	SEQUENCE FREQUENCY (PER RX YR)
		SAFETY VALVES OPEN	SAFETY VALVES CLOSE	RCIC	SUPPRESSOR POOL HEAT REMOVAL	HIGH PRESSURE INJECTION	MANUAL DEPRESSURIZATION	LOW PRESSURE INJECTION			
LOSS OF SERVICE WATER (4 2 E-4/RX)	AUTOMATIC SCRAM										
SW	C1	M	P	U2	M	U	X1	V			

The event tree diagram shows the progression of an accident sequence starting from the initiator 'SW'. The tree branches into several paths, each leading to a specific accident class and sequence designator. The paths are as follows:

- SW (OK) leads to SW/X (OK)
- SW/X (OK) leads to SW/W/U (OK)
- SW/W/U (OK) leads to SW/W/U/V (ID) with a frequency of 1×10^{-9}
- SW/W/U (OK) leads to SW/W/U/X1 (IA) with a frequency of 1×10^{-9}
- SW/W/U (OK) leads to SW/U2 (OK)
- SW/U2 (OK) leads to SW/U2/U (OK)
- SW/U2/U (OK) leads to SW/U2/U/V (ID) with a frequency of 1×10^{-7}
- SW/U2/U (OK) leads to SW/U2/U/X1 (IA) with a frequency of 1×10^{-9}
- SW (IDRV) leads to SW/P (IDRV) with a frequency of 1×10^{-9}
- SW (LLOCA) leads to SW/X (LLOCA) with a frequency of 1×10^{-9}
- SW (ATWS) leads to SW/C1 (ATWS) with a frequency of 1×10^{-9}

Figure 3.1-6

Loss of Service Water
Event Tree

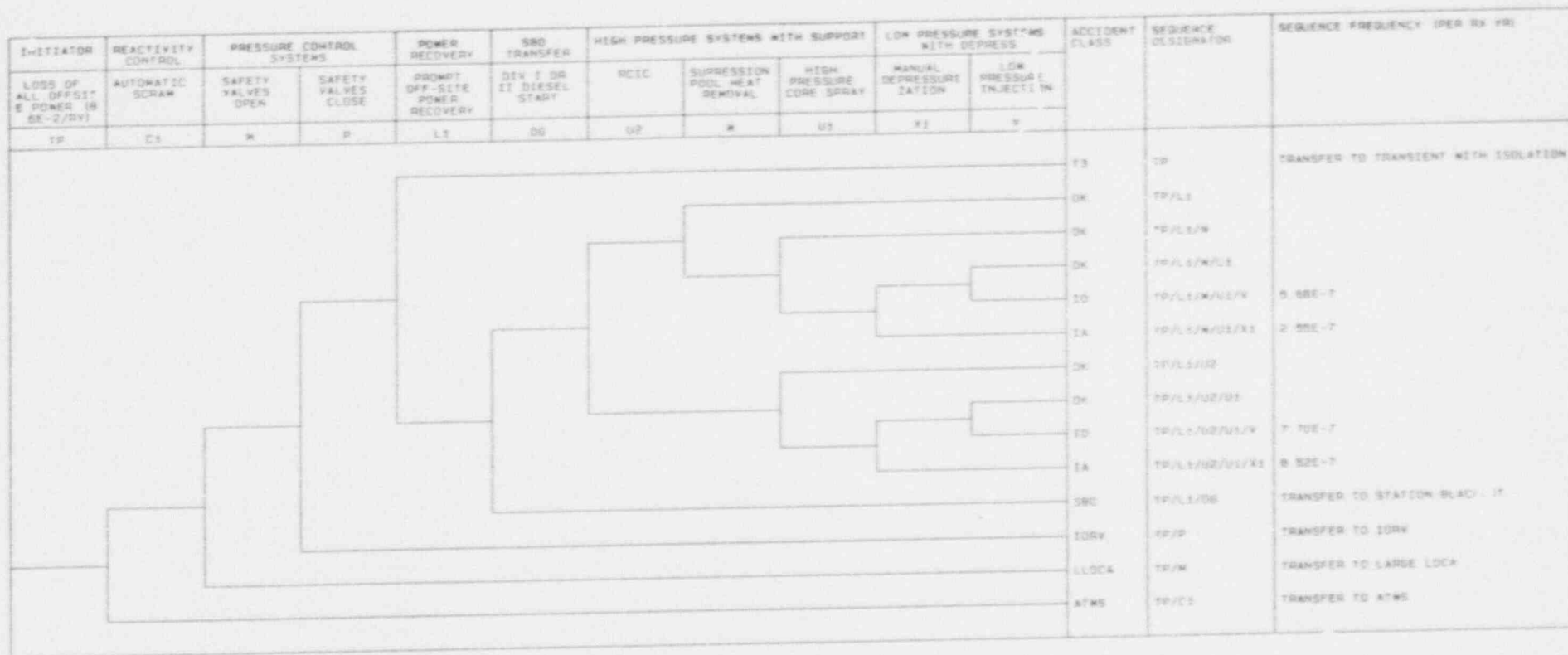

Figure 3.1-7

Loss of Off-site Power
Event Tree

TRANSFER FROM LOOP	HIGH PRESSURE SYSTEMS		POWER RECOVERY ACTIONS			CORE COOLING MAINTENANCE		DEPRESSURIZATION	CORE COOLING MAINTENANCE	ACCIDENT CLASS	SEQUENCE DESIGNATOR	SEQUENCE FREQUENCY (PER RX YR)
STATION BLACKOUT (1.4E-3/YR)	HIGH PRESSURE CORE SPRAY	RCIC	RECOVER OFFSITE POWER	RECOVER DIV 1 DIESEL GENERATOR	RECOVER DIV 2 DIESEL GENERATOR	SUPPRESSION POOL HEAT REMOVAL	FEEDWATER INJECTION	MANUAL DEPRESSURIZATION	LOW PRESSURE INJECTION			
TL	U1	U3	L4	DG1	DG2	W2	Q1	X1	V			
										OK	TL	
										OK	TL/U1	
										OK	TL/U1/W2	
										OK	TL/U1/W2/Q1	
										10	TL/U1/W2/Q1/V	< E-9
										1A	TL/U1/W2/Q1/X1	< E-9
										OK	TL/U1/L4	
										OK	TL/U1/L4/W2	
										10	TL/U1/L4/W2/V	< E-9
										1A	TL/U1/L4/W2/X1	< E-9
										OK	TL/U1/L4/DG2	
										OK	TL/U1/L4/DG2/W2	
										10	TL/U1/L4/DG2/W2/V	< E-9
										1A	TL/U1/L4/DG2/W2/X1	< E-9
										OK	TL/U1/L4/DG1	
										10	TL/U1/L4/DG1/V	< E-9
										1A	TL/U1/L4/DG1/X1	< E-9
										1B	TL/U1/L4/DG1/DG2	4.59E-6
										1B	TL/U1/VIS	5.24E-6

Figure 3.1-8

Station Blackout
Event Tree

INITIATOR	REACTIVITY CONTROL	HIGH PRESSURE SYSTEMS WITH SUPPORT				LOW PRESSURE SYSTEMS WITH SUPPORT		CLASS	SEQUENCE DESIGNATOR	SEQUENCE FREQ (NCY (PER RX YR))
		FEEDWATER INJECTION	REACTOR CORE ISOLATION COOLING	SUPPRESSOR POOL HEAT REMOVAL	HIGH PRESSURE CORE SPRAY	MANUAL DEPRESSURIZATION	LOW PRESSURE INJECTION			
SMALL BREAK LOCA (1E-3/RY)	AUTOMATIC SCRAM									
S2	C1	Q	U2	W	U1	X1	V			
								OK	S2	
								OK	S2/Q	
								OK	S2/Q/W	
								OK	S2/Q/W/U1	
								IIIIC	S2/Q/W/U1/V	< E-9
								IIIB	S2/Q/W/U1/X1	< E-9
								OK	S2/Q/U2	
								OK	S2/Q/U2/U1	
								IIIIC	S2/Q/U2/U1/V	< E-9
								IIIB	S2/Q/U2/U1/X1	< E-9
ATWS	S2/C1	TRANSFER TO ATWS								

Figure 3.1-9

Small Break LOCA
Event Tree

INITIATOR	REACTIVITY CONTROL	HIGH PRESSURE SYSTEM	LOW PRESSURE SYSTEMS WITH SUPPORT		CLASS	SEQUENCE DESIGNATOR	SEQUENCE FREQUENCY (PER RX YR)
MEDIUM BREAK LOCA (3E-4/YR)	AUTOMATIC SCRAM	HIGH PRESSURE CORE SPRAY	MANUAL DEPRESSURIZATION	LOW PRESSURE INJECTION			
S1	C1	U1	X1	V			
					OK	S1	
					OK	S1/U1	
					IIIIC	S1/U1/V	< E-9
					IIIB	S1/U1/X1	1.34E-8
					ATWS	S1/C1	TRANSFER TO ATWS

Figure 3.1-10

Medium Break LOCA
Event Tree

INITIATOR	REACTIVITY CONTROL	HIGH PRESSURE SYSTEM	LOW PRESSURE SYSTEMS	CLASS	SEQUENCE DESIGNATOR	SEQUENCE FREQUENCY (PER RX YR)
LARGE BREAK LOCA (1E-4/R)	AUTOMATIC SCRAM	HIGH PRESSURE CORE SPRAY	LOW PRESSURE INJECTION			
A	C1	U1	V	OK	A	
				OK	A/U1	
				IIIC	A/U1/V	< E-9
				ATWS	A/C1	TRANSFER TO ATWS

Figure 3.1-11

Large Break LOCA
Event Tree

INITIATOR	REACTIVITY CONTROL	CORE COOLING SYSTEMS				CLASS	SEQUENCE DESIGNATOR	SEQUENCE FREQUENCY (PER RX YR)
		FEEDWATER INJECTION	HIGH PRESSURE CORE SPRAY	MANUAL DEPRESSURIZATION	LOW PRESSURE INJECTION			
INTERFACING SYSTEM LOCA (5.00E-6)	MANUAL OR AUTOMATIC SCRAM							
T9	C	Q1	U1	X1	V			
						OK	T9	
						OK	T9/Q1	
						OK	T9/Q1/U1	
						III C	T9, Q1/U1/V	< E-9
						III B	T9/Q1/U1/X1	< E-9
						ATWS	T9/C	TRANSFER TO ATWS

Figure 3.1-12

Interfacing System LOCA
Event Tree

INITIATOR	REACTIVITY CONTROL	HIGH PRESSURE SYSTEMS WITH SUPPORT		LOW PRESSURE SYSTEMS	CLASS	SEQUENCE DESIGNATION	SEQUENCE FREQUENCY (PER RX YR)
		FEEDWATER INJECTION	HIGH PRESSURE CORE SPRAY	LOW PRESSURE INJECTION			
T4	C1	Q1	U1	V			
					OK	T4	
					OK	T4/Q1	
					OK	T4/Q1/U1	
					IIIC	T4/Q1/U1/V	1.06E-6
					ATWS	T4/C1	TRANSFER TO ATWS

Figure 1-13

Inadvertent Open Relief Valve
Event Tree

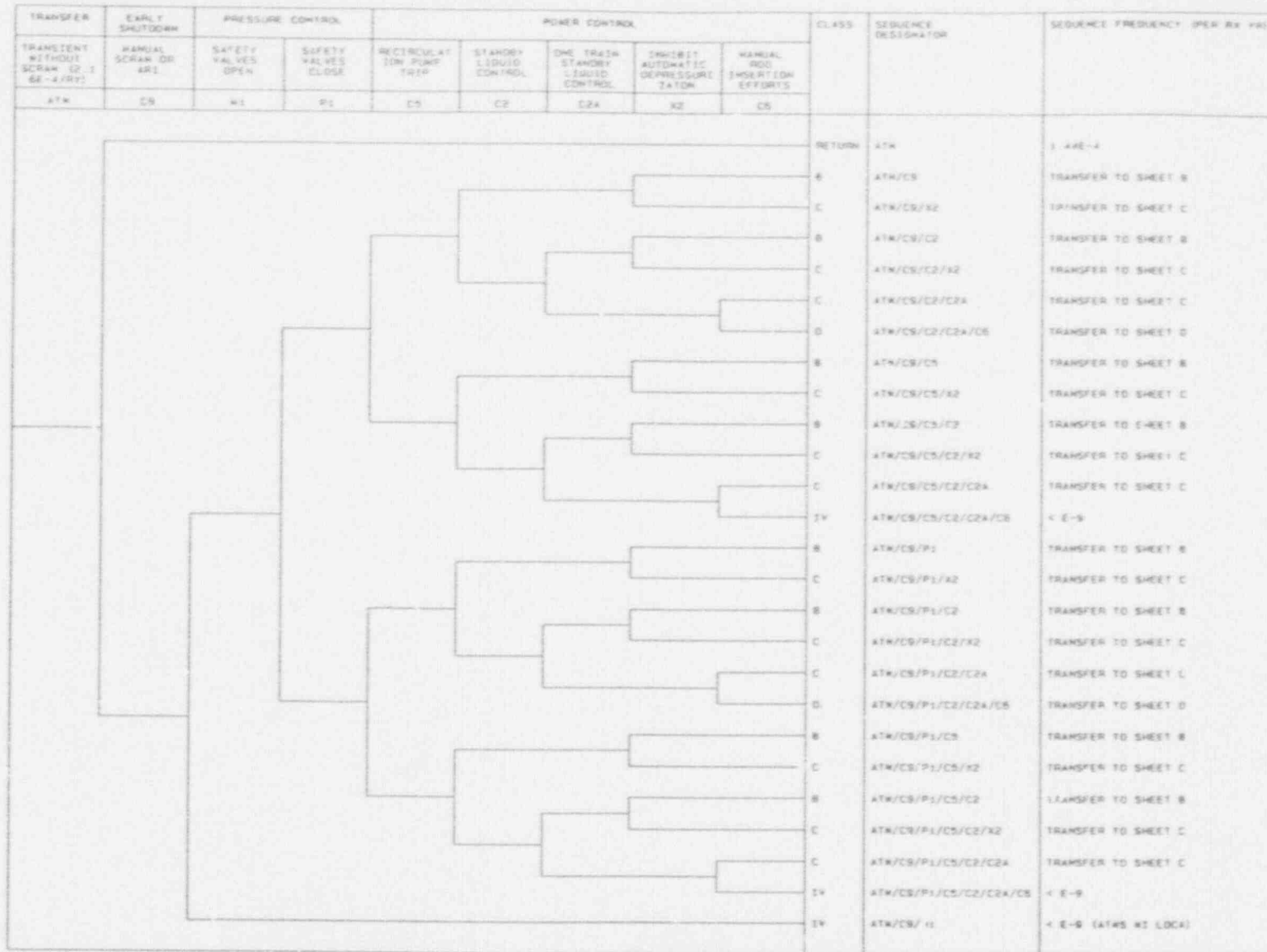

Figure 3.1-14

Anticipated Transient Without Scram
Event Tree-Sheet A

TRANSFER	CORE COOLING SYSTEMS					CLASS	SEQUENCE DESIGNATOR	SEQUENCE FREQUENCY (PER RX YR)
	ATWS HIGH PRESSURE TRANSFER (7.35E-5/R ⁴)	MAIN CONDENSER HEAT SINK	FEEDWATER INJECTION	HIGH PRESSURE INJECTION	MANUAL DEPRESSURIZATION			
B	Q2	Q	U	X1	V			
						OK	B	
						OK	B/Q	
						OK	B/Q/U	
						ID	B/Q/U/V	< E-9
						IA	B/Q/U/X1	< E-9
						OK	B/Q2	
						OK	B/Q2/U	
						ID	B/Q2/U/V	< E-9
						IA	2/U/X1	< E-9

Figure 3.1-15

Articipated Transient Without
Scram Event Tree-Sheet B

TRANSFER	CORE COOLING SYSTEMS		CLASS	SEQUENCE DESIGNATOR	SEQUENCE FREQUENCY (PER RX YR)
ATWS LOW PRESSURE TRANSFER (7.34E-7/RX)	HIGH PRESSURE INJECTION	LOW PRESSURE INJECTION			
C	U	V			
			OK	C	
			OK	C/U	
			ID	C/U/V	< E-9

Figure 3.1-16

Anticipated Transient Without
Scram Event Tree-Sheet C

TRANSFER	POWER CONTROL	RESPONSE SYSTEMS						CLASS	SEQUENCE DESIGNATOR	SEQUENCE FREQUENCY (PER RX YR)
ATWS NO SHUTDOWN TRANSFER (2 42E-7/RV)	ATWS WATER LEVEL CONTROL	MAIN CONDENSER HEAT SINK	FEEDWATER INJECTION	SUPPRESSOR POOL COOLING	HIGH PRESSURE INJECTION	REACTOR DEPRESSURIZATION	LOW PRESSURE INJECTION			
D	H1	G2	G	W1	U	X1	V			
								OK	D	
								IV	D/G	1.28E-8
								IV	D/G/U	< E-9
								IV	D/G/U/V	< E-9
								IV	D/G/U/X1	< E-9
								IV	D/G/W1	< E-9
								IV	D/G2	7.15E-8
								IV	D/G2/U	< E-9
								IV	D/G2/U/V	< E-9
								IV	D/G2/U/X1	< E-9
IV	D/G2/W1	5.57E-9								
IV	D/H1	6.45E-8								

Figure 3.1-17

Anticipated Transient Without
Scram Event Tree-Sheet D

3.2 System Analysis

This section provides a brief description of front-line and support systems as well as a discussion on how they were modeled in the Clinton Power Station (CPS) Individual Plant Examination (IPE). Also included is a discussion on the methods used to develop this information.

3.2.1 System Descriptions

System notebooks were developed for each of the systems modeled in the IPE. These notebooks are used as a collection point for the various pieces of information which describe the function of a system as well as its effect on core damage frequency.

The primary documents reviewed by the IPE analysts were the CPS piping and instrumentation drawings, electrical schematics, operating procedures, system description and one-line drawings. These documents describe the normal operation of the system as well as abnormal line ups that can be used to mitigate a transient. The system descriptions in the Updated Safety Analysis Report (USAR) and other design criteria and documents were also reviewed. These information sources provide a basic understanding of system operation.

The system models were reviewed by the system engineers in order to verify that modeling was correct and to incorporate insights from operations and failure history. The systems were also walked down in order to develop further insights on spatial dependencies such as room cooling, potential flooding sources, etc.

A system narrative was developed using the information referenced above. This narrative is a summary and describes the specific system functions modeled in the IPE. Also included are

interfaces and dependencies, success criteria, and significant assumptions made in developing the system models.

The following is a brief description of systems modeled in the IPE.

3.2.1.1 Reactor Protection System (RPS), Control Rod Drive (CRD) and Emergency Core Cooling Systems (ECCS) Initiation

The Reactor Protection System (RPS) initiates a rapid insertion of control rods (SCRAM) to shutdown the reactor if monitored system variables exceed pre-established limits. This action prevents the reactor from operating under conditions which threaten the integrity of the fuel cladding, the reactor coolant pressure boundary, or the containment building.

The RPS is primarily a logic system utilizing solid state components. The RPS is divided into four divisions which use four input sensor channels for each trip function (Figure 3.2-1). When more than four sensors are utilized for a trip function, the signals are combined into four input channels. Each instrument inputs to each of the divisions for that parameter. A signal from any two instruments for a parameter is required to produce a SCRAM signal (2 out of 4 logic). The signal can only be reset in the main control room after 10 seconds and after the abnormal condition that initially caused the SCRAM signal is cleared (Figure 3.2-2).

The RPS SCRAM signal de-energizes the A and B solenoids of the SCRAM pilot valves, SCRAM discharge volume (SDV) vent and drain pilot valves, and energizes the solenoids for the back up SCRAM valves (Figure 3.2-3). When the SCRAM pilot solenoids are de-energized, air is rapidly vented from the Control Rod Drive (CRD) System SCRAM valves causing them to open. The opening of the SCRAM valves results in a large differential pressure across the CRD piston, caused by applying high pressure water on the bottom

of the piston and the venting of the top side to the SCRAM discharge volume. The differential pressure causes rapid insertion of control rods into the core, thereby shutting down the reactor. Section 3.2.1.10 describes CRD as an injection source.

The Alternate Rod Insertion (ARI) subsystem is another method to initiate a SCRAM independent of the RPS. The purpose of this system is to mitigate the consequences of an Anticipated Transient Without Scram (ATWS). The ARI actuates on low reactor level or high reactor pressure. This system operates on a two out of two logic (Figure 3.2-4). When a trip signal is initiated, solenoid operated SCRAM pilot air header vent valves open to exhaust air from the pilot air header (the three way solenoid valve actuates to block the instrument air supply) and actuates two solenoid operated valves per system. The pilot air header vent valves also allow air to be exhausted from the air header to the SCRAM discharge volume vent and drain valves permitting these valves to close. These actions will rapidly reduce the water pressure on the top side of the CRD piston which will permit the control rods to be inserted into the core.

The ARI subsystem is modeled in the IPE with a single estimated failure probability. The RPS system is modeled as two basic events. One is the failure to SCRAM resulting from an electrical failure and the other is the failure to SCRAM resulting from a mechanical failure. The failure probability for these events was taken from NUREG/CR-4550, Analysis of Core Damage Frequency: Grand Gulf, Unit 1 Internal Events.

The Emergency Core Cooling Systems (ECCS) initiation system includes the automatic initiation logic for the High Pressure Core Spray (HPCS), Low Pressure Core Spray (LPCS), Residual Heat Removal (RHR), Reactor Core Isolation Cooling (RCIC), and diesel generators (DGs).

The ECCS initiation system consists of four divisions which monitor reactor water level, and drywell and containment pressure. If abnormal conditions are detected, an initiation signal is sent to the ECCS, RCIC, or DG systems as appropriate. The signal is sealed-in until the abnormal condition clears.

LPCS and the "A" loop of RHR will automatically start in the low pressure injection (LPCI) mode if a low reactor vessel level of -145.5" (Level 1) or high drywell pressure (1.68 psig) is detected. These parameters are monitored by four sensors which are physically separated from each other. These sensors are supplied by the division 1 DC bus. The output of these sensors are electrically combined in a series parallel configuration. This arrangement precludes the possibility that one single failure will prevent or cause an initiation (Figure 3.2-5).

The division 1 containment spray will initiate automatically if all of the following conditions are detected:

1. LPCI initiated for 10.17 minutes (either automatically or manually).
2. High drywell pressure (1.68 psig).
3. High containment pressure (22.3 psia).

Each of the above pressure parameters is monitored by two sensors. A trip of either sensor will cause a valid signal for that parameter. This precludes the possibility that a single failure will prevent an initiation (Figures 3.2-6 and 3.2-7).

The "B" and "C" loops of RHR are initiated in the LPCI mode in a manner similar to LPCS and RHR "A". Four separate instruments are used to monitor the same parameters and are physically separated from one another. These sensors are supplied by the division 2 DC bus. The logic is also similar to division 1 (Figure 3.2-8).

The division 2 loop of the containment spray is initiated in a manner similar to division 1. Different instruments than those used in division 1 are used to monitor the same parameters. These instruments are physically separated from one another and are fed from the division 2 DC bus. The logic is also similar to division 1 (Figures 3.2-9 and 3.2-10).

HPCS initiation occurs if a low reactor water level of -45.5" (level 2) or high drywell pressure is detected. Each parameter is monitored by four sensors which are physically and electrically separated from each other. The sensors are supplied by the Division 3 and 4 DC busses. The output of the sensors is combined in a series-parallel combination known as one out of two taken twice logic. This logic precludes the single failure of one sensor from preventing an initiation signal (Figure 3.2-11).

RCIC is automatically initiated if a low reactor level of -45.5" (level 2) is detected. This parameter is monitored by four sensors which also supply the initiation logic for division 1 and 2 LPCI. The output from these sensors is combined in a series-parallel configuration known as one out of two taken twice logic (Figure 3.2-12).

The ECCS initiation system is modeled in the IPE by the transmitters which sense reactor and containment parameters. The trip modules and the rest of the circuitry are not included in the model. This simplification is not expected to significantly affect the probability of failure because of the reliability and continual self-test feature of the solid state logic. These initiation logic circuits were modeled together to facilitate common cause modeling between the divisions. Additionally, only the automatic initiation logic is modeled. Manual initiation, if modeled, is included with the system fault trees or in recovery actions. Finally, although drywell pressure signals were built into the models, they were later disabled for HPCS, LPCS, and LPCI initiation, in order to facilitate quantification. This

deletion was shown to be acceptable by the fact that ECCS initiation failure events are relatively unimportant in the final results.

3.2.1.2 Feedwater Delivery System

The Feedwater (FW) delivery system provides continuously purified, heated, pressurized water from the main condenser hotwell to the reactor pressure vessel (RPV) during normal plant operation. Following a reactor trip, the FW delivery system provides a source of high pressure coolant. This is the normal means of ensuring proper reactor coolant inventory control during power operation and reactor shutdown and cooldown. The systems that are included in the FW delivery system include Condensate (CD), Condensate Polisher (CP), Condensate Booster (CB), and FW.

Four CD pumps, each rated at 33% capacity, take suction on the main condenser hotwell from a common suction header. Three of the four are normally running while the fourth is in standby. The pumps discharge water through the tube side of the steam packing exhausters, steam jet air ejectors (SJAEs) and off gas recombiners. Finally, the discharge reaches nine condensate polishers. The condensate polishers can be bypassed and the water discharged to the suction of the CB pumps (Figure 3.2-13).

The condensate polishers (Figure 3.2-14) purify the water by filtration and ion exchange and discharge to the suction of the CB pumps (Figure 3.2-15). There are four CB pumps rated at 33% capacity which discharge through two FW heater trains of 50% capacity each (Figure 3.2-15). Three of the four CB pumps are normally running. Each train consists of a heater drain cooler and five FW heaters. The heated water is discharged to the suction of two 50% capacity turbine driven reactor feed pumps (TDRFP) and a 33% capacity motor driven reactor feed pump (MDRFP).

The feedpumps discharge into a common header which supplies two high pressure FW heaters. The FW heaters discharge into a common header and then split into two lines before passing through containment penetrations and to the reactor. There are two containment isolation check valves in each line, one outside containment and the other inside the drywell (Figure 3.2-16).

The CB pumps can be used to inject into the RPV, when RPV pressure is less than approximately 725 psig. One pair of CD and CB pumps are used in this mode. The CD pumps can also be used to inject into the RPV if pressure is less than 250 psig.

Any one of the three feedpumps can be used for decay heat removal if the main condenser is available as a heat sink. If the main condenser is unavailable, makeup to the RPV can still be provided if water from the cycled condensate storage tank is used to provide makeup to the hotwell.

The FW Delivery System is modeled with two CD, two CB, and one FW pump initially running. Credit is taken for a TDRFP running only in an Anticipated Transient Without Scram (ATWS) scenario. All other events rely on the MDRFP being started, because steam flow is assumed insufficient to operate the TDRFPs for the 24 hour mission time in the IPE. Also modeled is one CB and one CD pump or one CD pump providing injection if the reactor can be sufficiently depressurized. All CP flow paths have been modeled as one basic event which is several flow paths plugged. Flow diversion has also been modeled since eleven potentially significant bypass flow paths exist. These flow paths could open as result of a support system failure such as loss of Instrument Air (IA) or loss of control power. These events would cause valves to fail open and result in diversion of flow back to the main condenser.

3.2.1.3 Main Steam

The Main Steam (MS) system delivers steam from the RPV to the main turbine during normal plant operation. After a reactor SCRAM, the MS system is the preferred method of removing decay heat from the RPV via the turbine bypass valves to the main condenser. Sixteen safety relief valves are located on the four MS lines before the inboard main steam isolation valves (MSIVs). Systems required for decay heat removal include MS, Condenser Air Removal (CA), Off Gas (OG), Turbine Gland Seal (GS) and Circulating Water (CW).

The main condenser is designed to condense the turbine exhaust steam and turbine bypass steam. It can accept up to 35% of rated steam flow through the bypass valves during normal and transient conditions. A vacuum must exist in the main condenser in order for it to perform this function. The CD, CW, and GS systems must operate successfully as well as either the CA or OG systems, to maintain condenser vacuum.

The MS system consists of four main steam lines starting at the RPV, penetrating the containment with inboard and outboard MSIVs and an outboard motor operated valve (MOV). Downstream of the MOV, the lines terminate at an equalizing header that distributes steam to the main turbine, bypass valve manifolds, steam jet air ejectors (SJAE), GS system, and TDRFPs (Figure 3.2-17).

Two SJAE trains are designed to remove non-condensable gases from the main condenser and exhaust to the OG System. Only one SJAE is required during normal plant operation. Two mechanical condenser vacuum pumps are also available to establish condenser vacuum when reactor power is less than 5%. One pump is sufficient to perform this function (Figure 3.2-18).

The OG system processes and controls the release of effluents from the SJAE trains. This is accomplished by processing the gases through components such as the recombiners, cooling condenser, gas dryers, charcoal adsorbers, and high efficiency

particulate (HEPA) filters. The OG system exhausts to the plant ventilation stack (Figure 3.1-19).

The SS System is designed to prevent air leakage into and radioactive steam leakage out of the main turbine. It provides non-radioactive seal steam to the main turbine shaft glands and valve stems (main stop, control, combined stop and intercept) from the normal seal steam source (steam seal evaporator). Heating steam is provided to the steam seal evaporator by MS or seventh leakage extraction steam. In the event that the normal steam source is lost, seal steam can be supplied by the Auxiliary Steam (AS) boilers or directly from the MS system (Figures 3.2-20 and 3.2-21).

The CW System is designed to deliver cooling water from Clinton Lake to the main condenser for condensing steam from the main turbine exhaust. The CW system is able to provide cooling water during normal and transient conditions. Although the CW System is not required to perform nuclear safety related functions, it is required when the main condenser is used as a heat sink. Four MS lines and three CW pumps are modeled in the CPS IPE. One MS line and one CW pump are necessary to remove decay heat. Additionally, one SJAE train or vacuum pump is in service to maintain condenser vacuum (Figure 3.2-22).

Safety Relief Valves and the Automatic Depressurization System (ADS) are not included in this model. These are discussed in section 3.2.1.8.

3.2.1.4 High Pressure Core Spray (HPCS)

The High Pressure Core Spray (HPCS) consists of a single motor-driven centrifugal pump which discharges through a series of valves and piping to a spray sparger located inside the reactor vessel (Refer to Figure 3.2-23). The system is designed to operate from normal off-site auxiliary power or from a

dedicated standby diesel generator. A keep full system ensures that the system is full of water to eliminate water hammer and ensure immediate response on system startup.

HPCS pump suction is either from the Reactor Core Isolation Cooling (RCIC) storage tank (primary source) or the suppression pool. If water level in the RCIC storage tank is low, or a high suppression pool level is detected, suction is automatically transferred to the suppression pool.

The HPCS system is designed to pump water into the reactor vessel over a wide range of pressures. Flow rates vary from 467 gallons per minute (gpm) at 1177 psid to 5010 gpm at 363 psid with a total runout flow of 6400 gpm at atmospheric conditions. The system is designed to deliver rated flow into the reactor vessel within 27 seconds of an initiation signal. HPCS will automatically initiate on a level 2 low reactor water level signal (-45.5") or a high drywell pressure (1.68 psig). The system can also be manually initiated.

When the HPCS pump receives an initiation signal, the minimum flow valve opens and diverts flow to the suppression pool. The valve closes when a normal discharge flow path is available which passes a minimum of 625 gpm. This protects the pump from damage if a normal flow path is not available.

Operation of the HPCS at the rated flow rates will provide emergency core cooling, aid in reactor vessel depressurization, and maintain vessel level following a large and medium break loss of coolant accident (LOCA).

The HPCS pump, motor, valves and keep full system are modeled in the CPS IPE. The initiation circuitry is modeled as part of the Emergency Core Cooling System initiation circuitry model.

3.2.1.5 Reactor Core Isolation Cooling

The Reactor Core Isolation Cooling (RCIC) consists of a turbine driven pump that receives its motive power from reactor decay heat and/or reactor fission steam. The steam is exhausted to the suppression pool. The pump discharges to the reactor pressure vessel (RPV) head spray. Suction sources for the pump include the RCIC storage tank (primary source) or the suppression pool (Figure 3.2-24).

RCIC will automatically initiate on a level 2 low reactor water level signal (-45.5") or high drywell pressure (1.68 psig) and supply make up water from the RCIC storage tank. The system can also be manually initiated. Injection will terminate when RPV water reaches +52" (level 8). When a low RCIC storage tank level or a high suppression pool level is detected, suction will automatically switch to the suppression pool.

The RCIC pump is protected by a minimum flow valve which will allow flow to the suppression pool. If RCIC pump discharge pressure is greater than 125 psig and flow is less than 120 gpm, the minimum flow valve will open. When flow reaches 240 gpm, the minimum flow valve closes.

The RCIC system is designed to assure that sufficient reactor vessel water inventory is maintained so that adequate core cooling is assured. The operation of this system will prevent core damage under the following conditions:

1. The reactor vessel is isolated and maintained in hot standby.
2. The reactor vessel is isolated and coolant flow from the Feedwater (FW) delivery system is lost.
3. A SCRAM is initiated due to the loss of normal FW flow and the reactor is not depressurized to the point at

which the Residual Heat Removal (RHR) system can be placed in shutdown cooling.

Flow from the RCIC system is sufficient to supply make up for a small break LOCA.

The RCIC gland seal system prevents the leakage of radioactive steam past the RCIC turbine seals into the room. However, the gland seal compressor is designed to trip when reactor water level reaches level 2. The tripping of this compressor is assumed not to affect the length of time that the pump may continue to operate provided room cooling is available.

The RCIC pump, tank, turbine, valves, and fill system are all modeled in the Individual Plant Examination (IPE). Initiation circuitry for RCIC is included in the Emergency Core Cooling System initiation circuitry fault tree.

3.2.1.6 Low Pressure Core Spray

The Low Pressure Core Spray (LPCS) system consists of a centrifugal, four stage vertical pump that takes suction from the suppression pool. The discharge of the pump is routed into a spray sparger directly over the reactor core (Figure 3.2-25).

The LPCS is designed to provide a high quantity of water at low pressure. The system provides about 5,000 gpm to the core and will automatically initiate when reactor pressure vessel (RPV) level reaches -145.5" (level 1) or a high drywell pressure (1.68 psig) signal is received. The system can also be initiated manually. Water cannot be injected into the vessel until the RPV injection valve receives an open signal. This signal is generated when RPV pressure decreases to 472 psig. Additionally, the injection check valve will not open until LPCS pressure is

greater than reactor pressure. The pump is protected from damage when not injecting to the RPV by a minimum flow line that allows water to be recirculated back to the suppression pool. There are interconnections between the LPCS and the "A" train of the Residual Heat Removal (RHR) system. A suction line connection between the LPCS pump suction and the suction of the A RHR pump is provided to allow full flow RPV to RPV testing of the LPCS System. A spectacle flange is installed between the two systems when testing is not in progress. A keep full system is shared between the LPCS and the "A" RHR systems as are flushing lines, minimum flow lines, and test return lines.

The LPCS pump, motor, and valve interdependencies are modeled where appropriate in the Individual Plant Examination. Initiation circuitry for LPCS is modeled in the Emergency Core Cooling System initiation circuitry fault tree.

3.2.1.7 Residual Heat Removal

The Residual Heat Removal (RHR) is composed of three trains of safety related components. Trains "A" and "B" are able to operate in 4 modes as follows: 1) low pressure coolant injection (LPCI), 2) containment spray, 3) suppression pool cooling, and 4) shutdown cooling. Train "C" will only operate in the LPCI mode. Each RHR Train is independent (Figure 3.2-26) with the following exceptions: 1) RHR "A" and "B" trains share a common shutdown cooling suction line, 2) RHR "B" and "C" share a common power source, room cooling water supply, and a common fill pump. RHR "A" also shares a fill system and room cooling water supply with the Low Pressure Core Spray (LPCS) system.

The LPCI mode of RHR is designed to pump water directly from the suppression pool to the reactor core if reactor pressure is below 472 psig. When initiated, the pumps are protected by a minimum flow line that diverts flow back to the suppression pool until the LPCI injection valve opens. The LPCI injection valve will

not open until it receives an open permissive signal when reactor pressure is below 472 psig. Additionally, the injection check valve will not open until RHR pressure is greater than reactor pressure.

Initiation logic for LPCI is included in the ECCS initiating events model. The systems can be manually initiated if the pumps fail to start automatically.

The containment spray mode uses the "A" or "B" RHR pump to pump water from the suppression pool through the respective heat exchanger to the containment spray header. Operation in this mode reduces temperature in the containment building. The system initiates 10 minutes after LPCI initiates and a signal for high drywell and containment pressure (1.68 and 7.6 psig respectively) is received. The delay allows LPCI to ensure that the core remains covered. Upon receipt of the initiation signal, train A will initiate immediately while train B has a 90 second delay. Containment spray can also be initiated manually.

The suppression pool cooling mode is similar to the containment spray mode except that the water is discharged directly to the suppression pool. The reactor injection valves and containment spray valves remain closed. This mode of operation removes heat from operation of the safety relief valves or Reactor Core Isolation Cooling (RCIC). This mode of operation must be manually initiated.

The shutdown cooling mode is used to cool the reactor core when reactor pressure is below 135 psig. The "A" or "B" RHR pump takes suction from the "B" Reactor Recirculation (RR) line and discharges through the respective heat exchanger back to the reactor via the feedwater system. Shutdown cooling must be manually initiated.

The LPCI and suppression pool cooling modes of RHR are modeled in the front end analysis of the Individual Plant Examination. The containment spray mode of RHR is modeled in the back end analysis. Shutdown cooling was not modeled because it is not needed to prevent core damage during the 24 hour mission time of the IPE. Automatic initiation of the RHR modes is modeled in the Emergency Core Cooling System initiation circuitry fault tree. One RHR heat exchanger is necessary to ensure proper system operation in all modes except LPCI.

3.2.1.8 Automatic Depressurization System (ADS)

The Automatic Depressurization System (ADS) is composed of seven safety relief valves (SRVs) each with an associated air accumulator; a parallel bank of twelve air amplifiers; and two divisions of backup air bottles with associated control circuitry. When open, the SRVs discharge steam from the reactor pressure vessel (RPV) to the suppression pool. The purpose of the ADS system is to reduce reactor pressure in the event of a Loss of Coolant Accident (LOCA) coincident with a failure of the High Pressure Core Spray (HPCS) system so that Low Pressure Coolant Injection (LPCI) systems are able to inject water into the RPV (Figure 3.2-26). Two low level setpoint SRVs are also included in the model because they are connected to the backup air supply.

ADS control circuitry sends an open signal to both of the solenoids for each of the seven SRVs. The open signal is produced in several ways (Figures 3.2-27 and 3.2-28). If reactor level is sensed at level 1 and level 3 concurrent with high drywell pressure, ADS will initiate 105 seconds after receiving the signal. The time delay allows HPCS to reflood the vessel. If a level 1 and level 3 low reactor water level is sensed without high drywell pressure, ADS will initiate after six minutes. This is an initiation sequence for accidents that do not involve a pipe break inside the drywell. Also included is a permissive

interlock that allows ADS to initiate after at least one of the three Residual Heat Removal (RHR) pumps have started in the LPCI Mode or the Low Pressure Core Spray (LPCS) pump has started. In practice, the CPC EOP's direct the operators to inhibit the automatic actuation function of the ADS system. This requires ADS actuations to be manually initiated.

Upon actuation an open signal is sent to both solenoids on each SRV, however only one solenoid is necessary for the SRV to open. Analysis has shown that only one of the nine modeled SRVs is required for successful system operation. The motive power for each SRV is provided by the Instrument Air (IA) system. The IA system pressure is raised by air amplifiers to SRV operating pressure. If the IA system is lost, each SRV is connected to one of two separate divisions of compressed air bottles. The ADS/Low Low Setpoint (ADS/LLS) motor-operated backup air supply isolation valves can be opened from the Main Control Room. Each ADS/LLS SRV has an air accumulator that will allow SRV operation if both the normal and back up air supply were lost. These air accumulators provide for uninterrupted operation of the SRVs in the event the motor-operated valves cannot be opened during loss of power, and allow sufficient time for operator action to manually open the valves. However, the air accumulators are assumed to be inadequate for the entire mission time of the SRVs and are not included in the system model as a source of compressed air.

The remaining 7 SRVs are capable of being operated as power operated relief valves. These valves have air accumulators which are smaller and are not connected to the backup air supplies. The valves will open automatically upon receipt of a high reactor pressure signal from the Nuclear Boiler system. Additionally, the valves will open automatically without the benefit of an air supply to prevent overpressurization of the RPV. These valves would be isolated from their normal sources of IA upon a level 2 low reactor water level. This level 2 signal will be present

under accident conditions when ADS would be required. Since these SRVs are not connected to the backup supply and their accumulators are not large enough to supply air for the entire mission time, they are not included in the model.

3.2.1.9 Standby Liquid Control (SLC) System

The Standby Liquid Control (SLC) System consists of two injection pumps and a storage tank that contains a neutron absorber solution (sodium pentaborate). This system provides a method to shutdown the reactor if a sufficient number of control rods can not be inserted (Figure 3.2-29).

A common suction header comes from the storage tank and branches into two lines with a normally closed motor operated valve on each. Two parallel positive displacement pumps rated at 43 gallons per minute at 1220 psig. pump the solution into the reactor via the High Pressure Core Spray sparger. Downstream of the pumps are two explosive valves. A crosstie exists between the discharge lines upstream of the explosive valves so that flow from the pumps will reach the reactor if an explosive valve fails to open. The system can only be manually initiated.

Both pumps are modeled in the Individual Plant Examination (IPE). Successful reactor shutdown is achieved if one or both pumps operate and inject the neutron absorber solution into the reactor pressure vessel, although the time available for the operator to manually start this system is less if only one pump functions.

3.2.1.10 Control Rod Drive (CRD) Injection

The Control Rod Drive (CRD) System, under normal plant operating conditions, provides a means of controlling reactor power by inserting and withdrawing control rods from the reactor core.

The system consists of two 100% capacity pumps that supply water to the Hydraulic Control Units (HCUs). The HCUs are used to control the flow of water to the control rod drives (Figure 3.2-30).

As part of the design, the CRD system provides a small continuous flow of purified water to the reactor vessel (approximately 47 gpm). This flow provides cooling for the CRD mechanisms. The flow of water to the reactor could be increased to approximately 150 gpm to provide makeup to the reactor. To achieve this higher system flow rate the standby pump would have to be manually placed in service and flow control valves opened. If the operators took no action to increase CRD flow, CRD flow would automatically increase to approximately 140 gpm after a reactor SCRAM at rated pressure. This is the flow rate used in the IPE model.

The CRD system has been modeled to provide post SCRAM flow to the reactor vessel. Other functions of the system such as level control and a source of cooling water for the Reactor Recirculation (RR) pump seals have not been modeled.

3.2.1.11 Containment Vent Capability

Emergency containment venting is used during accident conditions when all other decay heat removal mechanisms are inadequate, when primary containment pressure is well beyond calculated values for any design basis accident, when containment structural integrity is directly or indirectly threatened, or as a method to reduce hydrogen concentration with the containment.

The CPS containment control emergency operating procedure (EOP) directs the operator to vent the containment via any path not necessary for core cooling when containment pressure approaches 45 psig and suppression pool level is less than 54 feet. If containment pressure exceeds the above limit, then the operator

is directed to vent via all available paths regardless of whether or not the system is necessary for core cooling. There are six possible paths to vent the containment, but only three are of sufficient size to independently vent the containment when pressurized due to decay heat, up to 40 hours following a SCRAM. The three vent paths modeled are described below.

The flow path for venting containment to the spent fuel pool via the RHR system is through the containment spray sparger, through the RHR piping to the RH/FC system cross connection, through the FC system to the spent fuel pool (Figure 3.2-31). All valves that must be opened are modeled in the IPE.

The flow path for venting containment to the spent fuel pool via the FC system is through the scuppers and skimmers in the upper containment pool, down the FC return header to the spent fuel pool (Figure 3.2-32). All valves that must be opened are modeled in the IPE.

Both of the above paths allow the releases to be scrubbed by water in the spent fuel pool.

The flow path for venting the containment through the CCP system is through the CCP system piping then through a hole cut into the duct work (Figure 3.2-56). This results in an unscrubbed release to the atmosphere. Both Containment Building Ventilation (VR) system valves and cutting of the hole are modeled in the IPE.

3.2.1.12 Hydrogen Igniters

The Hydrogen Igniter (HI) system is used to maintain post accident hydrogen concentration below 4%. The HI system contains 115 glow plug type igniters split into two independently powered divisions. The igniters are located throughout the drywell and

containment with at least one igniter from each division located with a maximum separation distance of 30 ft. in each general area. The igniter system is designed to conduct a slow burn of any hydrogen present in the drywell and containment.

The complete system is modeled in the IPE.

3.2.1.13 Auxiliary AC Power System (On-site, Off-site and Switchyard).

The Auxiliary Power (AP) system at Clinton Power Station includes all major Alternating Current (AC) power supplies. Safety-related buses are supplied from two off-site power sources and three on-site diesel generators. The non-safety buses can be supplied by one off-site source and, when the unit is operating, from the output of the main generator through the unit auxiliary transformers (UATs) (Figures 3.2-33, 3.2-34, 3.2-35, and 3.2-36). After a plant trip, the non-safety buses automatically switch to the Reserve Auxiliary Transformer (RAT).

Off-site power sources consist of a 345 KV switchyard feeding the RAT and a 138 KV transmission line serving the emergency reserve auxiliary transformer (ERAT). The 345 KV switchyard is fed from three independent transmission lines each terminating in a breaker and a half ring bus. This provides redundancy and flexibility in switching power sources. The RAT feeds 6.9 KV non-safety and 4.16 KV non-safety and safety related buses. The 138 KV transmission line, which is fed from two different substations and is independent of the switchyard, feeds the ERAT which in turn feeds the safety-related 4.16 KV buses. The normal supply for the safety-related buses is the RAT. If the P. is lost, the bus automatically transfers to the ERAT, if available, or to its respective diesel generator.

The onsite emergency power sources are three diesel generators with their independent auxiliaries. The division 1 and 2 diesel generators are tandem 12 and 16 cylinder diesel engines with a generating capacity near 4 Megawatts (MW) at 4.16 KV. The Division III diesel generator is a single 16 cylinder diesel engine with a capacity of just over 2 MW at 4.16 KV. Each diesel generator is located in an isolated room with independent fuel supplies, cooling water supplies, heating ventilating and air conditioning systems, air start systems and other utilities.

The diesel generators will automatically start if one of the following signals is received:

1. Loss of off-site power
2. Low reactor water level (level 2 for Division 3, level 1 for Divisions 1 and 2)
3. High drywell pressure
4. Degraded bus voltage

After each diesel generator has accelerated to approximately the rated frequency and voltage, the feed breaker will close if normal off-site power has not been restored. Each diesel generator, once started, must be manually shutdown.

The system is modeled in the IPE with the RAT and ERAT available unless a loss of off-site power (LOOP) is initiated. Auto transfer of the non-safety buses from the UATs to the RAT after a plant trip is also included in the model.

3.2.1.14 Direct Current (DC) and Nuclear System Protection System (NSPS) Power Supplies

The Direct Current (DC) power system at Clinton Power Station (CPS) consists of six independent 125 VDC battery systems with their chargers, motor control centers and auxiliaries. There are eight 120 volt Alternating Current (AC) buses supplied

independently by various solid-state inverters. Four of the DC and inverter supplied buses are safety related with safety related power supplies. Two additional buses are safety related, although they are supplied by multiple non-safety power sources. The remaining two buses are non-safety related (Figures 3.2-37 through 3.2-42).

Each divisional battery is designed to supply all necessary loads on its bus for four hours following a loss of its AC power supply if load shedding is performed by the operators within one hour. Each battery charger is designed to supply all loads on its bus and simultaneously charge the respective battery. The four safety related battery chargers are supplied from their respective divisional safety related AC sources. There are no cross connections between these buses. However the two non-safety DC buses can be manually cross connected.

The four safety related 120 volt AC buses supply the Nuclear System Protection System (NSPS). Each NSPS bus is supplied by its own inverter. An alternate power supply is provided from a safety related AC bus. Each inverter contains a solid state selector switch for the supply. The DC battery and inverter source is the normal supply, however the selector switch will automatically transfer to the AC source if the inverter output is unavailable or is out of specification. Additionally, there is a manual transfer switch in the event the solid state selector switch fails.

There are two non-divisional safety related inverter supplied buses for loads such as the main steam isolation valves and SCRAM solenoids. These buses have inverters powered by the non-safety related batteries with backup from an AC supply. These inverters have a manual transfer switch.

The last two inverter supplied buses are for balance of plant (BOP) loads, such as the process computer, and are similarly

supplied from the two non-safety related DC buses with a solid-state and manual bypass supplies from an AC bus.

The batteries, battery chargers, and inverters systems are modeled in the Individual Plant Examination. The support systems modeled include the AC power supplies and three redundant cooling systems for each inverter.

3.2.1.15 Shutdown Service Water System (SX)

The Shutdown Service Water System (SX) provides cooling water to safety related equipment used to maintain the reactor and containment in a safe condition when the normal balance of plant (BOP) systems are not capable of performing their intended functions. Cooling loads typically served by SX include the Residual Heat Removal (RHR) heat exchangers, the emergency diesel generator heat exchangers, the RHR pump seal coolers, and numerous area coolers. These coolers are used to cool areas of the plant where safety related equipment with significant heat loads are located. Coolers are provided in areas such as Emergency Core Cooling System (ECCS) rooms, Reactor Core Isolation Cooling room, safety related switchgear areas, and Standby Gas Treatment Rooms. These cooling system dependencies are modeled in the Individual Plant Examination.

The SX system is composed of three independent subsystems corresponding to the three electrical safety divisions. Each division consists of a pump that takes suction from the ultimate heat sink and pumps through basket type strainers to the cooling loads (Figures 3.2-43 through 3.2-47).

During normal plant operation, the SX system is in standby and the Plant Service Water System (WS) provides flow to each SX division through crosstie valves. Upon receipt of a Loss of Coolant Accident (LOCA) signal (high drywell pressure or low reactor water level) the SX pumps start and the WS/SX cross tie

valves close. The SX pumps will also start upon receipt of low header pressure signal. This would occur under loss of off-site power (LOOP) conditions, for example, when the WS pumps would be unavailable. The pumps can also be manually started. These are the functions of the SX system modeled in the Individual Plant Examination.

The SX system also can supply cooling flow to the control room chillers, fuel pool cooling heat exchangers and reactor recirculation pump seals and motor bearings; and make up water to the reactor pressure vessel, suppression pool, or spent fuel pools. These functions have not been modeled in the Individual Plant Examination.

3.2.1.16 Plant Service Water System (WS)

The Plant Service Water (WS) System is a large capacity lake water cooling system that supplies cooling flow to primarily balance of plant (BOP) systems. The WS system also supplies cooling flow to safety related loads during normal plant operation through cross ties to the SX system (Figures 3.2-48 to 3.2-51).

The system consists of three pumps which take suction from the lake and discharge into a common header. Lake water flows through two strainers both of which are usually in service, and into the plant. During winter months only one pump would normally be required. During summer months, two pumps would normally be required for full power operation but up to three can be used.

For the purposes of the Clinton Power Station IPE only one WS pump and one WS strainer is needed to supply the necessary flow to those support systems in service.

3.2.1.17 Service Air/Instrument Air (SA/IA)

The Service Air System (SA) provides a source of clean dry air to the Instrument Air System (IA) and to various other plant components. The IA system is the source of clean dry, compressed air for plant instrumentation and operation of pneumatic equipment.

The system consists of three centrifugal, four stage compressors that discharge into a common header. The header discharges into three identical Service Air (SA) dryers and then into various ring headers (Refer to Figure 3.2-52).

The compressors are sized so that only one compressor is necessary to supply normal system loads and maintain IA and SA system pressure between 80 and 100 psig. While one compressor is running, one of the remaining two is in standby. The third is isolated. The standby compressor will automatically start if system pressure drops below 80 psig.

The dryers are dual chamber desiccant type rated at 1836 scfm at 120°F and 120 psig at a dewpoint of -40°F. If system pressure drops below 70 psig, the drying chambers isolate and an automatic bypass valve opens to prevent reducing the efficiency of the desiccant beds. The dryers are also equipped with pre- and after-cartridge filters.

The SA dryer outlet header supplies the IA ring headers on two different branches. The first branch consists of the turbine building ring header supplying the auxiliary/fuel building ring header. The second branch consists of the radwaste ring header supplying the control building ring header. Containment and drywell ring headers are supplied from the auxiliary/fuel building ring header. The two branches are cross connected between the auxiliary/fuel building and control building ring headers. The radwaste and control building ring headers are

equipped with auto isolation valves which close when air pressure in either header drops to 70 psig. Auto isolation valves are not provided in the turbine building or auxiliary/fuel building ring headers so that IA supplies to loads in the containment and drywell are most reliable.

The three SA compressors, the SA dryers, and the ring headers are modeled in the Individual Plant Examination.

3.2.1.18 Component Cooling Water System (CC)

The Component Cooling Water (CC) system is a closed cooling water system consisting of three pumps and two heat exchangers which remove heat from plant equipment. Examples of served equipment include the Service Air (SA) compressors and Reactor Recirculation (RR) pump seal coolers. Plant Service Water (WS) cools the CC System (Figure 3.2-53).

CC water is discharged from the three pumps into a common header. Two heat exchangers operate in parallel between the pump discharge header and a common system header. Two pumps are normally in service with both heat exchangers. One pump and one heat exchanger are necessary to remove the required heat load and are modeled in the IPE.

3.2.1.19 Turbine Building Closed Cooling Water System (WT)

The Turbine building Closed Cooling Water (WT) System is a closed cooling system serving major components in the turbine building. Example components served include the Condensate Booster pumps and motor driven Feedwater pump. WT is cooled by Plant Service Water (Figure 3.2-54).

Two pumps discharge to a common header which in turn discharges to two heat exchangers. Normally one pump and one heat exchanger is required for system operation. One of each in service to remove heat loads is modeled in the IPE.

3.2.1.20 Fire Protection (FP)

The primary purpose of the Fire Protection (FP) System is to detect and extinguish a fire throughout the plant and adjoining structures. The system consists of three diesel driven fire pumps, a keep full pump, and an extensive network of ring headers throughout the plant and site connecting to fire hose stand pipes and sprinkler systems (Figure 3.2-55). One of the diesel fire pumps is located in the make up water pumphouse and is normally valved out of service. The remaining two pumps, located in the screenhouse, will start when a drop in system pressure is detected. They can also be manually started.

The FP system is cross connected to the WS system. This cross connection allows the fire pumps to be used as a source of injection into the reactor pressure vessel. The flow path would be through FP, into WS and into SX and finally into RHR. A check valve between the WS and FP system would need to be disassembled to use this injection source. This is the only function of the FP system modeled in the Individual Plant Examination.

3.2.1.21 Containment Isolation

The Containment and Reactor Vessel Isolation Control (CRVIC) system provides the instrumentation required to actuate the closure of containment isolation valves in the event of gross fuel cladding failures and/or breach of the reactor coolant pressure boundary. This prevents the gross release of radioactive material to the environment by closing isolation valves which isolate piping that penetrates primary and secondary

containment and/or the drywell whenever monitored parameters exceed limits.

During normal plant operation, the CRVIC logic systems are energized. When abnormal conditions are detected, the associated logic channel trips to the deenergized state and initiates group isolations.

The isolation signals from the CRVIC system are assigned to 20 individual groups. Each group has specific parameters which feed its isolation logic. Groups 1 through 13 are containment isolation, groups 14 through 18 are drywell isolation and group 19 is secondary containment isolation. Group 20 is miscellaneous valves which close on a containment isolation signal but are not containment isolation valves.

Four sensor channels (one for each division) are provided for each parameter in the group 1 Main Steam (MS) isolation logic. With one exception, these channels feed into a two out of four logic configuration resulting in closure of all inboard and outboard MSIVs. The exception is the MS line high flow trip function which has four sensors, one for each division, on each main steam line. Any two out of four on any line, will result in the closure of all MSIVs.

For all remaining groups, a trip in the division 1 logic will cause closure of the outboard isolation valves and division 2 logic will close the inboard isolation valves. The logic is generally one of two taken twice.

The Containment isolation is successful if either the inboard or outboard isolation valve in each line closes.

The CRVIC system includes the following instrumentation subsystems.

1. Reactor vessel low water level
2. High MS line radiation
3. High MS line flow
4. Low MS line pressure
5. Low main condenser vacuum
6. High MS tunnel ambient temperature
7. High turbine building area temperature
8. High drywell pressure
9. High Reactor Water Cleanup (RWCU) flow
10. High RWCU area temperature
11. High Residual Heat Removal (RHR) system area temperature
12. High Reactor Core Isolation Cooling (RCIC) room temperature
13. Low RCIC steam line pressure
14. High RCIC steam line flow
15. High RCIC turbine diaphragm pressure
16. High RCIC steam tunnel temperature
17. High radiation in ventilation systems penetrating secondary containment
18. High containment pressure

System components were included in the model if the failure could potentially disable the system. Components which have more than one failure mode which could disable the system have each failure mode modeled individually. Components whose failure rates are extremely low were not included in the model.

3.2.2 Fault Tree Methodology

Fault trees were used in the probabilistic risk assessment (PRA) to model plant systems and to determine system failure probabilities. The fault trees were then linked together to accurately reflect intersystem dependencies. They were then quantified to determine core damage probabilities as dictated by

event tree logic. Fault trees developed for the Clinton Power Station (CPS) Individual Plant Examination (IPE) are shown in Table 3.2-1.

Front-line systems are generally characterized as providing a critical safety function relating to accident mitigation. Examples include reactor depressurization or coolant injection. Support systems provide functions necessary to ensure operability of front-line systems. System fault trees were developed using the Electric Power Research Institute (EPRI) Computer Aided Fault Tree Analysis (CAFTA) fault tree manager. These fault trees were linked together with CAFTA and then quantified using the personal computer version of Set Equation Transformation System (PCSETS). The front-line system fault trees were developed to allow the support system fault tree to be linked directly into the logic when quantification is performed. This assures that system interdependencies are correctly modeled.

A prime consideration in developing fault trees is the level of detail to be included. One criterion is the availability of reliability data for components. For example it is not necessary to model a pump down to its bearings or a control circuit down to its contacts if reliability data for these smaller components are not available. If all failures of the pump and control circuit are included in one failure of interest (e.g., pump fails to start), then that is the level of detail used.

Data were also used to determine what component/failures to model based on relative importance. Faults associated with passive components, such as pipes or manual valves, were eliminated from further consideration if, for example, the system contains a pump with a particular failure mode of $1E-2$ compared with $1E-7$ for pipe rupture, or $1E-5$ for the manual valve failing to remain open. These passive failure modes do not contribute

significantly to the system failure rate when compared to the pump failure and are excluded from the model.

Transfers are used to connect different sections of a fault tree or to connect one fault tree to another. Transfers are also used to duplicate logic that may appear two or more times in a fault tree. For any situation in which a front-line system requires a support system in order to function correctly, a transfer from the appropriate portion of the fault tree for that support system is used.

A basic event describes a component fault or human error that requires no further development. Basic events were not defined below the level of detail for which component failure data was available. For example, plant records are typically maintained for motor operated valves failing to open or close, but not for all the specific causes of failure. Therefore, motor operated valves were not modeled in detail. Each basic event was assigned a failure probability before an estimate of the system failure probability could be determined. Generic data was used for component reliability data except for the diesel generators. Plant specific data was used for the diesel generators as well as maintenance intervals and system downtime for the other systems. Table 3.2-2 is a summary of components and failure modes for basic events that were generally included in the fault tree models.

The time required to fail a component is an important consideration. Failure of a support requirement such as motive or control power typically results in immediate component failure. However, failure of support requirements such as loss of lubrication or seal failure may allow the component to operate for some period of time and accomplish its required function.

To assess the affect that redundant components have on the total failure probability for a system, common cause failure was

considered. The approach for modeling and quantifying common cause failures is discussed in Section 3.3.4.

High Pressure Core Spray (HPCS), Low Pressure Core Spray (LPCS), Reactor Core Isolation Cooling (RCIC), Alternate Rod Insertion (ARI), and Residual Heat Removal (RHR) initiation logic were included in one model along with the auto start logic for the diesel generators. The initiation logic was modeled in this manner because one train of logic produces an initiation signal for more than one system. This method accurately reflects system dependencies. For example Division 1, supplies an initiation signal to LPCS, RHR "A", and RCIC, Division 2 supplies an initiation signal to RCIC and RHR "B", and "C" Divisions 3 and 4 provide an initiation signal to HPCS. This also facilitated common cause failure modeling for similar components.

3.2.3 Dependency Matrices

Dependency matrices are shown in Tables 3.2-3 through 3.2-5. Table 3.2-3 shows which initiating events have an influence on a front-line system. Table 3.2-4 shows which front-line systems have an influence on other front-line systems. Table 3.2-5 shows which support systems have an influence on front-line systems. These tables are useful for visualizing dependencies and performing a completeness review. To ensure that all intended links between various fault trees were included in the model, a computer program was developed that checks inputs to each gate from another fault tree to ensure that all required inputs actually exist.

Table 3.2-1

CPS IPE Fault TreesFront Line Systems

Feedwater Delivery (includes Feedwater, Condensate Booster, Condensate, and Feedwater Control)
High Pressure Core Spray
Low Pressure Core Spray
Main Steam (includes Main Steam, Main Condenser, Condenser Air Removal, and Circulating Water)
Automatic Depressurization (includes Safety Relief Valves and Air Accumulators Back-up Air Bottles)
Residual Heat Removal (includes Low Pressure Coolant Injection, Containment Spray, and Suppression Pool Cooling)
Reactor Core Isolation Cooling
Emergency Core Cooling System/Alternate Rod Insertion Initiation
Standby Liquid Control
Fire Protection (as an injection source)
Control Rod Drive (as an injection source)
Hydrogen Igniters
Containment Venting
Containment Isolation

Support Systems

Auxiliary Power (includes Auxiliary Power, Switchyard, Diesel Generator, Diesel Oil, and Diesel Ventilation)
Direct Current Power (includes Inverter, Nuclear System Protection System Power Supplies, and Switchgear Heat Removal)
Instrument Air (does not include Automatic Depressurization System Air)
Shutdown Service Water (includes Emergency Core Cooling System Heat Removal)
Miscellaneous Support (includes Plant Service Water, Turbine Building Closed Cooling Water, Plant Chilled Water, and Component Cooling Water)

Table 3.2-2
Components/Failure Modes/Transfers Included in the PRA Fault
 Trees

<u>Component</u>	<u>Failure Mode</u>	<u>Support System</u>
Pump*, Fan*, Air Compressor*	Fails to Start Fails to Run	Lube Oil Cooling AC DC (May be required for breaker operation)
Diesel Generator	Fails to Start Fails to Run	Engine Cooling DC HVAC Diesel Oil
Motor Operated Valve*	Fails to Open Fails to Close Changes Position Plugged	AC DC
Air Operated Valve (Includes Solenoid Valve)	Fails to Open Fails to Close Fails to Remain Open Fails to Remain Closed Plugged	AC or DC (for Solenoid Operation) Instrument Air
Check Valve	Fails to Open Fails to Close	
Manual Valve	Leakage Plugged Fails to Open	
Filter/Screen/ Heat Exchanger	Plugged	
Bus, Battery, Inverter Charger, Transformer	Output failure	AC DC
Basket Strainer	Plugged Motor Fails to Run Motor Fails to Start	AC
Analog Trip Module	Failure	

* Associated circuit breakers were not explicitly modeled for these components although those in the power distribution system were modeled..

TABLE 3.2-3

INITIATING EVENT TO FRONT-LINE DEPENDENCY SYSTEM MATRIX

INITIATING EVENT	FEEDWATER DELIVERY	HPCS	LPCS	MS	ADS INITIATION SUPPORT	RHR	RCIC	ECCS ARE INITIATION	SLC	FP	RD	HI	CNMT VENT	CNMT ISOLATION
LOSS OF SERVICE WATER	X(21)			D(2)	D(20)						X			
LOSS OF INSTRUMENT AIR	X(19)			X(18)	D(20)						X		P(8)	
LOSS OF DC	X(16)	P(7)	P(7)	D(17)	X	P(7)	X	X			X			
LOSS OF FEEDWATER	X			D(2)										
TRANSIENT WITH ISOLATION	P(1)			X										
LARGE BREAK LOCA	X(5)						X(4)		X(4)	X(4)	X(4)			
MEDIUM BREAK LOCA	X(5)		X(8)			X(8)	X(4)		X(4)	X(4,8)	X(4)			
SMALL BREAK LOCA			X(8)			X(8)			X(4)	X(4,8)	X(4)			
INADVERTENT/ OPEN SRV							X(4)		X(4)	X(4)	X(4)			
LOSS OF OFFSITE POWER	X			P(22)	P(13)						X			P(3)
STATION BLACKOUT	X	P(10)	X	P(22)	P(13)	X	D(12)	P(14)	X	P(11)	X	X	P(15)	X
ANTICIPATED TRANSIENT WITHOUT SCRAM														
TRANSIENT WITHOUT ISOLATION														
INTERFACING SYSTEM LOCA	P(9)	P(9)	P(9)	P(9)		P(9)	X(4)		X(4)	X(4)	X(4)			

X - COMPLETE DEPENDENCE - Front-line system not available following initiation.

P - PARTIAL DEPENDENCE - Front-line system partially unavailable following initiator (e.g. one loop or division available).

D - DELAYED DEPENDENCE - Delayed impact on front-line system unavailability (e.g. loss of component cooling).

Table 3.2-3
Initiating Event to Front-line System
Dependency Matrix

- (1) The turbine driven reactor feed pumps would not be available. However, the motor driven pump would be available for reactor makeup.
- (2) The Main Steam Isolation Valves (MSIVs) will eventually close since Feedwater (FW), Condensate Booster (CB) and Condensate (CD) are not able to pump down the hotwell.
- (3) If either the Division 1 or 2 Diesel Generator fails to start then only one of two Containment Isolation Valves would close.
- (4) System capacity is insufficient for makeup in this transient.
- (5) Capacity in hotwell is insufficient to bring plant to safe shutdown condition. Makeup can be made from the cycled condensate storage tank but makeup rate is also insufficient.
- (6) Instrument Air (IA) is needed to open Containment Continuous Purge (CCP) valves.
- (7) Loss of DC will prevent the starting or stopping of an Emergency Core Cooling System (ECCS) pump but it will not trip a running pump.
- (8) System will not inject into the reactor unless the reactor is depressurized.
- (9) System would be unavailable if the boundary break occurred in that system.
- (10) High Pressure Core Spray (HPCS) is available if Division III diesel generator is available. Station blackout only considers loss of off-site power with Division I and II diesel generators unavailable as defined by NUMARC 87-00, "Guidelines and Technical Basis for NUMARC Initiatives Addressing Station Blackout at Light Water Reactors".
- (11) Fire Protection is available as an injection source if both HPCS and RCIC have failed and reactor pressure is low. However, it would take several hours to align the system for injection.
- (12) RCIC will fail in 4 hours upon battery depletion.

Table 3.2-3 (Cont.)
Initiating Event to Front-line System
DC Dependency Matrix

- (13) Availability of ADS would be reduced because under loss of off-site power or station blackout conditions, Instrument Air (IA), which is the normal air source, would be unavailable. The backup air bottles would be needed.
- (14) Emergency core cooling initiation would be available as long as the batteries are available. Operators to complete shedding DC loads within one hour of a station blackout to prolong battery life.
- (15) Only one containment vent path through the Fuel Pool Cooling and Cleanup (FC) System is available under station blackout condition.
- (16) Loss of either non-safety DC bus results in loss of FW.
- (17) Depending on which DC bus is lost, one or two circulating water pumps would be lost. This could lead to loss of main condenser as a heat sink.
- (18) Loss of IA results in loss of condenser vacuum and main steam isolation valve (MSIV) closure.
- (19) FW would be lost because air operated control valves fail open resulting in a flow diversion.
- (20) Automatic Depressurization (ADS) would be lost once the air in the backup air bottles was expended.
- (21) Loss of Plant Service Water (WS) results in a total loss of balance of plant equipment.
- (22) Under loss of off-site power or station blackout conditions, the MSIVs would close due to a loss of IA.
- (23) Operators are not allowed to use systems to inject into the reactor shroud during an anticipated transient without SCRAM (ATWS) until reactor water level is lowered to below top of active fuel and the reactor is depressurized.

TABLE 3.2-4
FRONT-LINE SYSTEM TO FRONT-LINE SYSTEM DEPENDENCY MATRIX

FRONTLINE SYSTEM	REACTIVITY CONTROL		HIGH PRESSURE INJECTION				RPV DEPR	LOW PRESSURE INJECTION				CONTAINMENT CONTROL					
	RP	SC	HP	RI	FW	CRD	ADS/SRV	LPCS	LPCI	CD/CB	FP	MS	RHR SPRAY	RHR SP PL COOL	HI	CNMT VENT	CNMT ISOL
RP																	
SC																	
HP																	
RI																	
FW									X		P(8)						
CRD																	
ADS/SRV				D(3)				P(5)	P(5)	P(5)	D(21)						
LPCS							P(6)	P(10)			P(9)	P(10)	P(10)				
LPCI							P(6)	P(10)		X(12)	P(9)	X(17)	X(19)			X(18)	
CD/CB					X(1)	D(7)					X(8)						
FP																	
MS				X(11)	P(2)			P(5)	P(2.5)	P(5)	X(14)						
RHR CNMT SPRAY								X(17)		X(12)						X(15,16)	
RHR SUPP POOL COOL				D(4)				X(19)		X(12)						X(18)	
HI																	
CNMT VENT							D(16)	X(16)				X(18)	X(18)				P(20)

X - COMPLETE DEPENDENCE - Front-line system not available following failure of other front-line system.
P - PARTIAL DEPENDENCE - Front-line system partially unavailable following (e.g. one loop or division available).
D - DELAYED DEPENDENCE - Delayed impact on front-line system unavailability.

Table 3.2-4

Front-Line System to Front-Line System Dependency Matrix

- (1) Loss of Condensate (CD) or Condensate Booster (CB) will cause loss of Feedwater (FW).
- (2) Closure of the main steam isolation valves (MSIVs) will limit the amount of makeup available from the hotwell and will cause a loss of steam to the turbine driven reactor feed pumps. Makeup is available from the cycled condensate storage tank.
- (3) Reactor Core Isolation Cooling (RCIC) does not have the capacity to provide water at a sufficient rate to make up the inventory lost from a stuck open relief valve at normal operating pressure. Additionally, if ADS successfully reduced pressure then RCIC would be unavailable.
- (4) If RCIC provides high pressure injection, then suppression pool cooling must be provided within 24 hours.
- (5) Low pressure injection systems cannot provide injection if reactor vessel pressure cannot be reduced using Automatic Depressurization (ADS)/Safety Relief Valves (SRVs) or main condenser.
- (6) ADS will not automatically initiate unless a signal is received that at least one Residual Heat Removal (RHR) pump starts in the Low Pressure Coolant Injection (LPCI) mode or the Low Pressure Core Spray (LPCS) pump started.
- (7) Pump is normally aligned to the cycled condensate storage tank. Suction can be switched to the CD system if the cycled condensate tank is not available.
- (8) The main condenser relies on the CD/CB systems to remove condensate from the hotwell.
- (9) The MSIVs receive an automatic isolation upon receipt of a low reactor water level (level 1) signal. This signal also causes the LPCS and the RHR pumps to start in the LPCI mode. The main condenser would be lost as a heat sink.
- (10) The "A" RHR loop shares a keep full pump and full flow test line with the LPCS system.
- (11) Steam supply for the RCIC turbine is from the "A" main steam line before the inboard MSIV.

Table 3.2-4 (Cont.)

Front-line System to Front-Line System Dependency Matrix

- (12) Fire protection can be aligned to inject water into the reactor pressure vessel through Plant Service Water (WS) to Shutdown Service Water (SX) to the "B" RHR loop in the LPCI mode.
- (13) CD must be available to remove condensate from the main condenser.
- (14) One main steam line and one Circulating Water (CW) pump must be available to remove decay heat from the reactor via the main condenser after a plant trip.
- (15) The RHR, in conjunction with the Fuel Pool Cooling and Cleanup System (FC), provide a flow path for venting the containment to the spent fuel pool.
- (16) If containment pressure rises above 55 psig, the SRVs will not remain open.
- (17) A loop of RHR can not operate in the containment spray and LPCI mode concurrently
- (18) When RHR is used for containment venting, that loop can not be used for LPCI or containment spray.
- (19) A loop of RHR can not operate in the suppression pool cooling and LPCI mode concurrently.
- (20) Containment venting requires isolated valves to be opened.
- (21) Failure of SRVs/ADS could result in a MS line rupture.

Table 3.2-5

Front-Line to Support System Dependency Matrix

- (1) Condensate Booster (CB)/Condensate (CD) minimum flow valves fail open on a loss of Instrument Air (IA).
- (2) Shutdown Service Water (SX) is the primary source of room cooling. The pump will continue to run for a period of time after SX is lost.
- (3) Supplies power to the pump room cooling fan, keep full pump and system isolation motor operated valves.
- (4) Plant Service Water (WS) provides a back up source of cooling.
- (5) IA is used to operate drain valves while the system is in standby. IA is not needed when the system is in operation.
- (6) Turbine Building Closed Cooling Water (WT) provides cooling water to all motor driven pumps for lube oil cooling.
- (7) Provides cooling to the Turbine Oil (TO) System which is used for the flow regulating valve on the motor driven reactor feed pump.
- (8) Instrument air would have to be restored to flow control valves 1C11F00?A and B if reactor low water level isolations had occurred to maximize the use of the Control Rod Drive (CRD) pumps as an injection source.
- (9) 480 VAC is needed to open the valves to the backup air accumulators.
- (10) Can be used to recharge air accumulators.
- (11) Shutdown Service Water (SX) provides cooling water to the pump motor lube oil cooler. SX is also a source of cooling water for room cooling. The pumps will continue to run for a period of time after SX is lost.
- (12) Fire Protection (FP) can be aligned to inject into the reactor pressure vessel through WS to SX to the "B" loop of the Residual Heat Removal (RHR) System in the Low Pressure Core Injection (LPCI) mode if reactor pressure is low. Division II 480 VAC power is needed to open motor operated valves that are normally closed.

Table 3.2-5 (Cont.)

Front-Line to Support System Dependency Matrix

- (13) SX provides cooling to the "A" and "B" RHR heat exchangers. SX also supplies cooling water to the RHR pump motor lube oil coolers and room cooling. The pumps will continue to run for a period of time after room cooling is lost.
- (14) IA provides a source of air to the main steam isolation valve (MSIV) air accumulators.
- (15) AC and DC power must be available to run one Circulating Water (CW) pump and to operate various motor operated valves.
- (16) The 480 VAC system is normally used to provide power to the Containment Continuous Purge (CCP), RHR, and Fuel Pool Cooling and Cleanup System (FC) valves. Containment isolation valves require both Division 1 and Division 2 to operate. If 480 VAC is not available then backup measures are available to open the valves.
- (17) IA is normally used to open CCP Containment isolation valves. If IA is not available then backup measures are available to open the valves.
- (18) FC provides a flow path for venting the containment to the spent fuel pool either by itself or with the RHR system.
- (19) The CCP system provides the piping and isolation valves for venting the containment directly to the atmosphere.
- (20) A loss of balance of plant (BOP) AC and DC power results in an automatic reactor SCRAM. A loss of two Nuclear System Protection System (NSPS) power supplies result in an automatic reactor SCRAM.
- (21) Divisions 3 and 4 supply an initiation signal to the High Pressure Core Spray (HPCS) system.
- (22) Division 1 and 2 supply an initiation signal to the Reactor Core Isolation Cooling System.

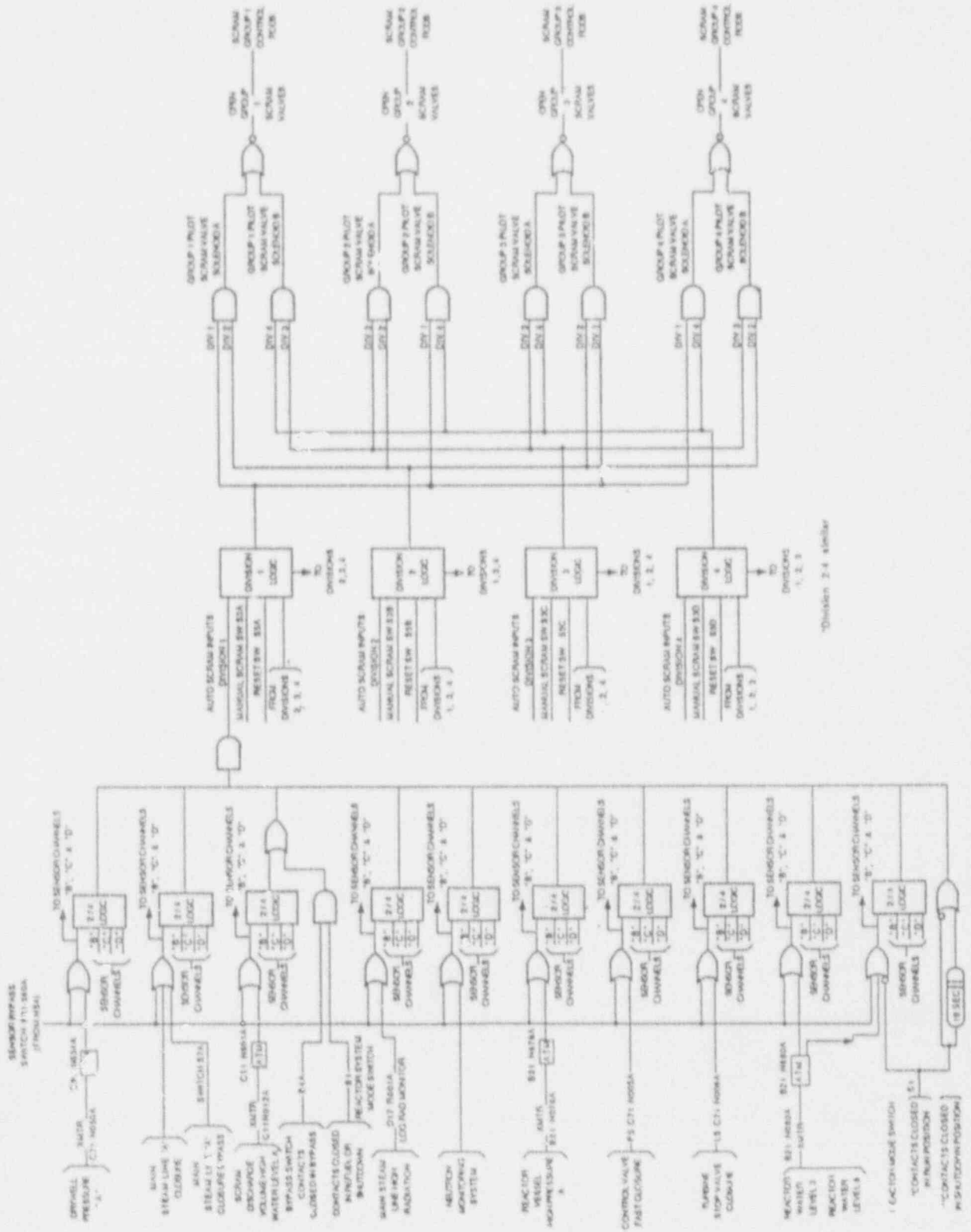

Figure 3.2-1
Simplified Scram Logic

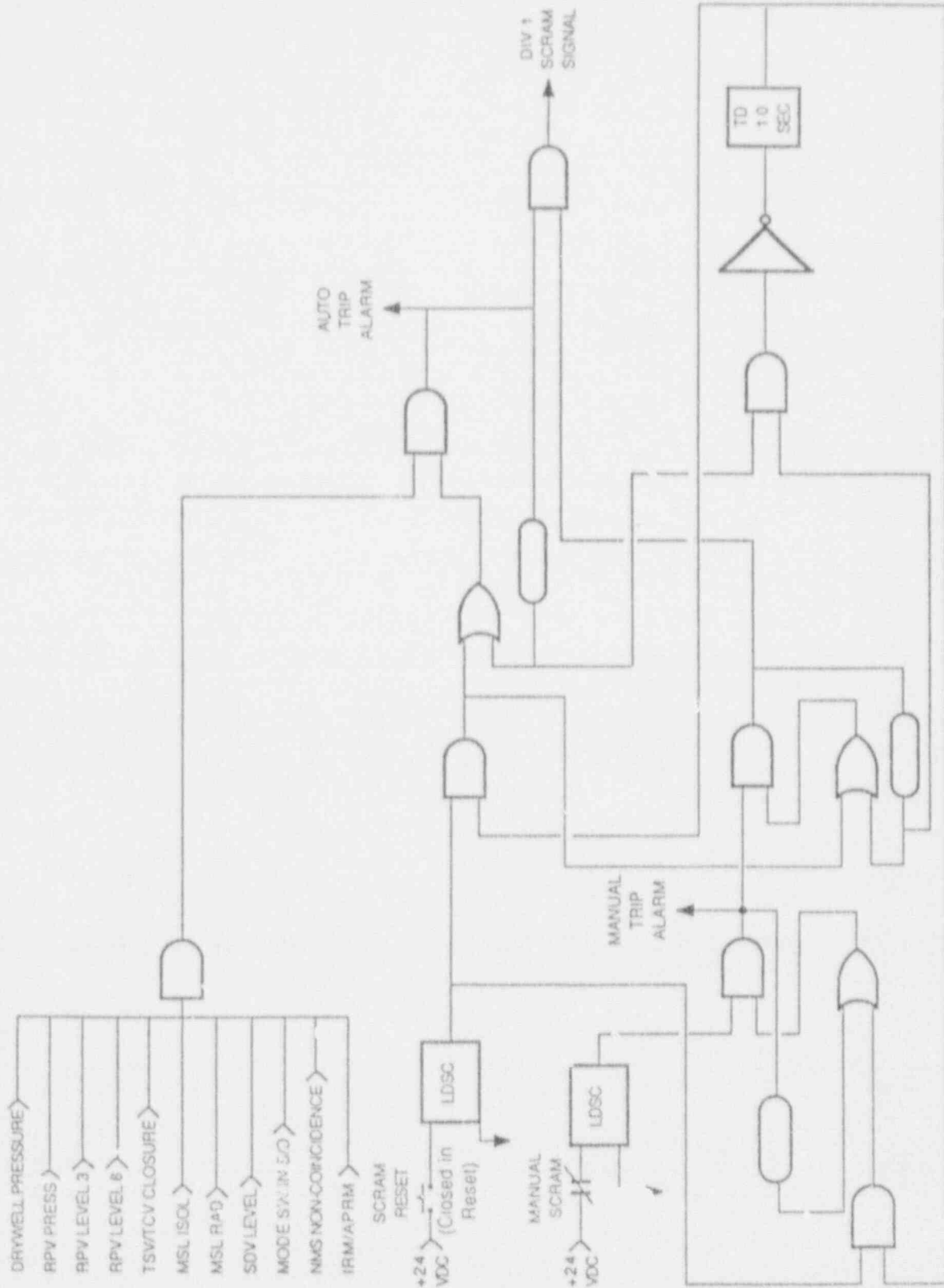

Figure 3.2-2
Division 1 Scram Seal-In/Reset Logic

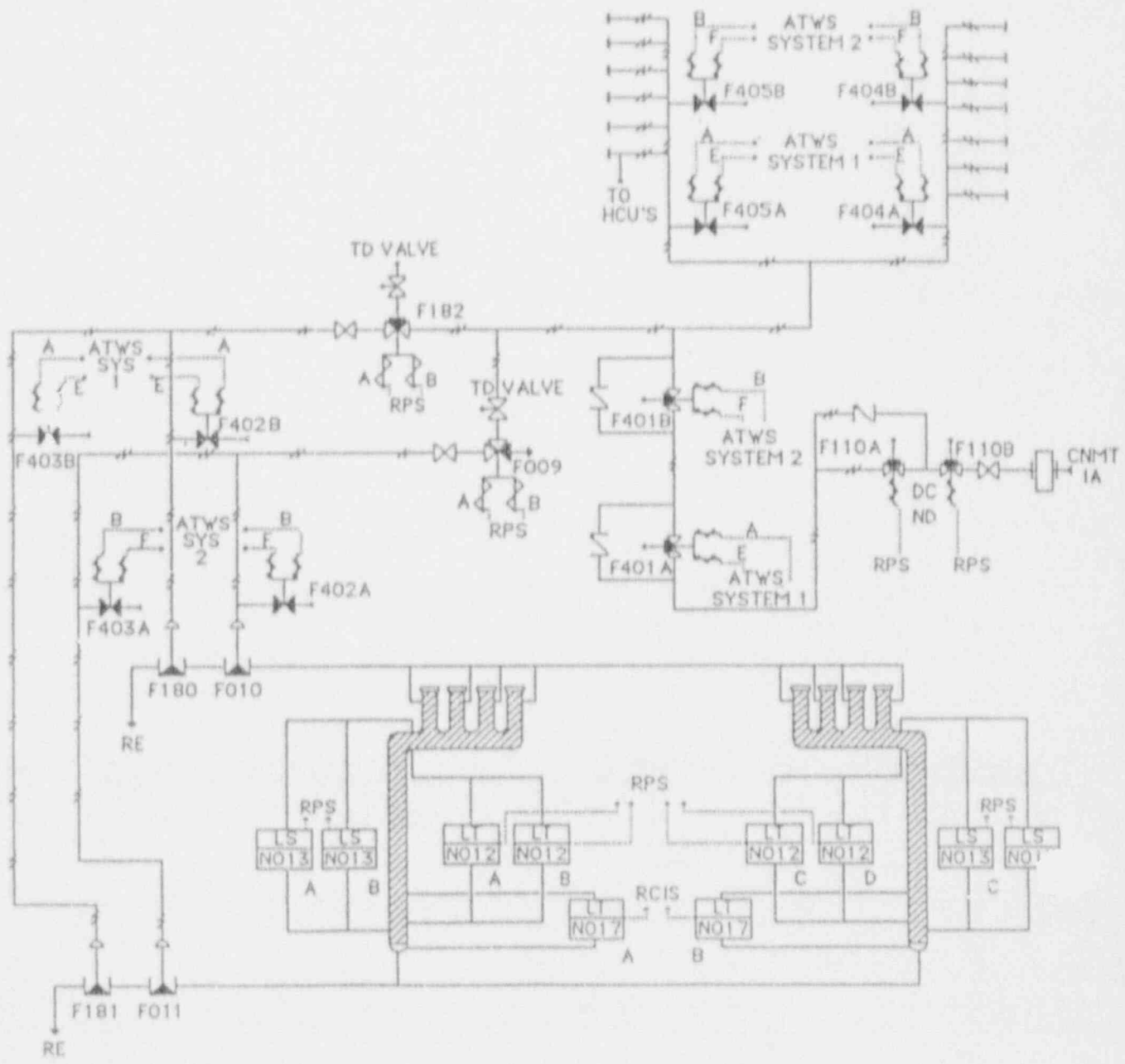

Figure 3.2-3
Scram Discharge Volume

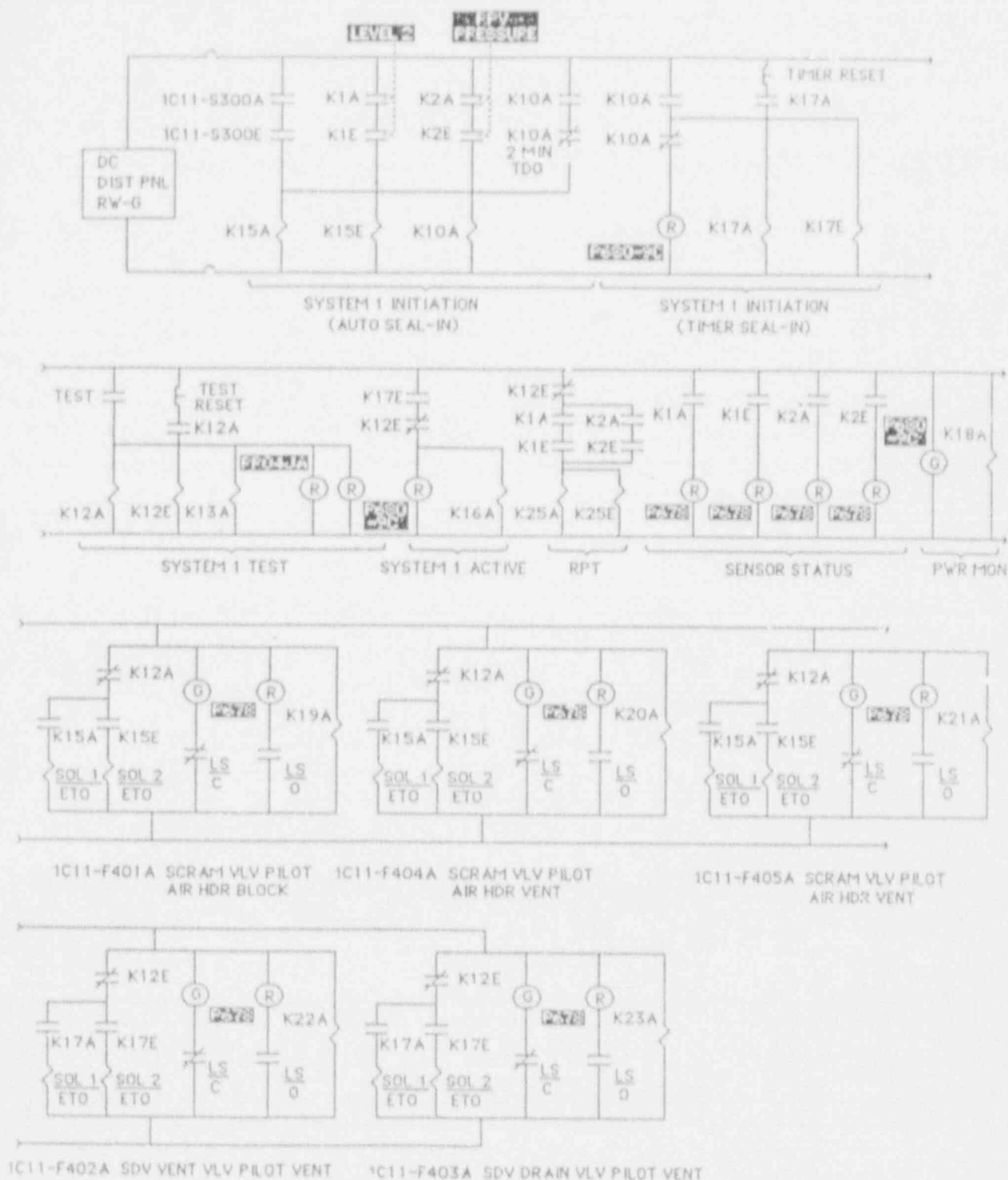

Figure 3.2-4
ARI/RR Pump Trip
Logic

Legend

FIG 2 = Figure 3.2-6
 FIG 3 = Figure 3.2-7

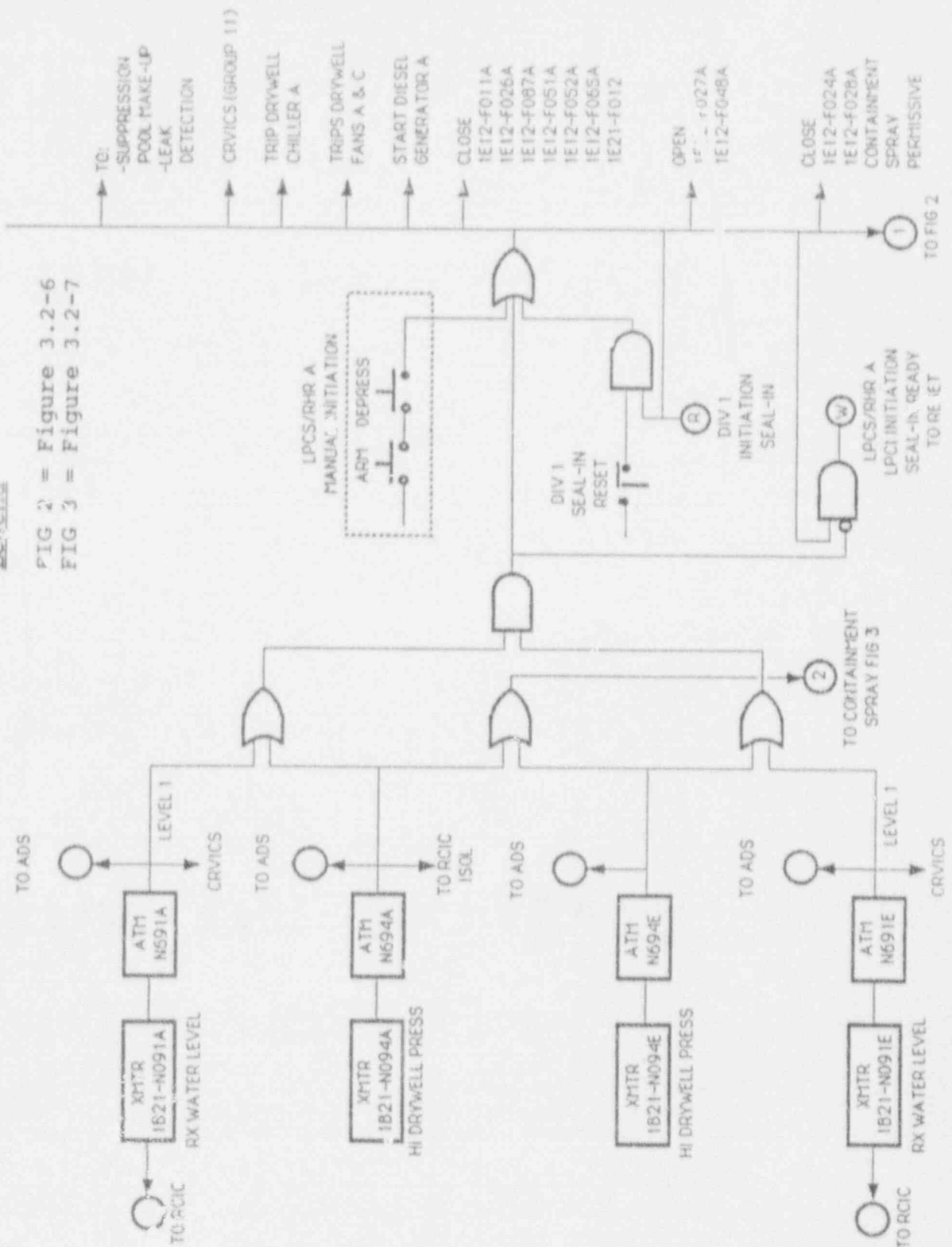
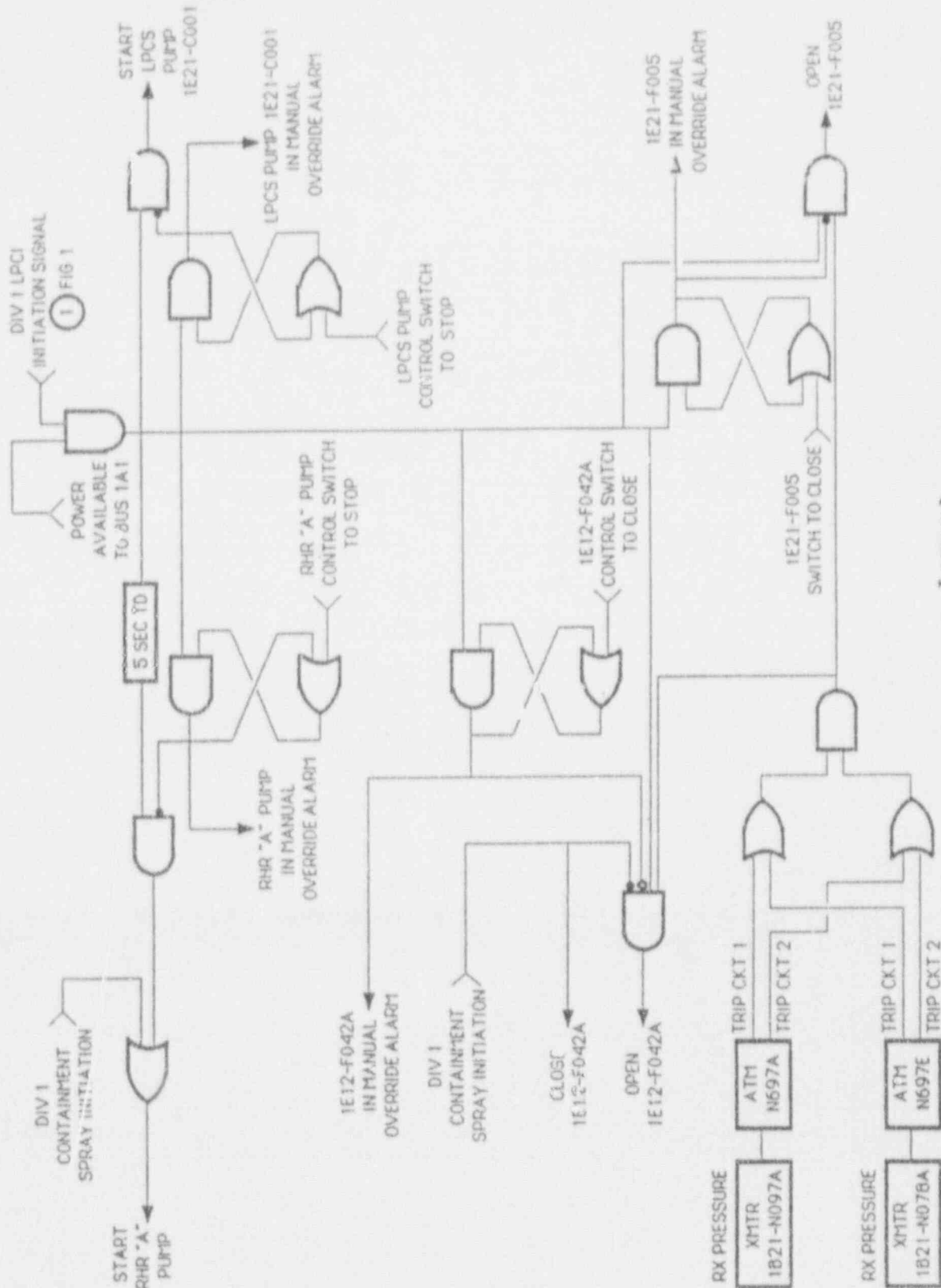

Figure 3.2-5
 Division 1 Initiation Logic
 Sheet 1



Legend

Figure 3.2-6
Division 1 Initiation Logic
Sheet 2

FIG 1 = Figure 3.2-5

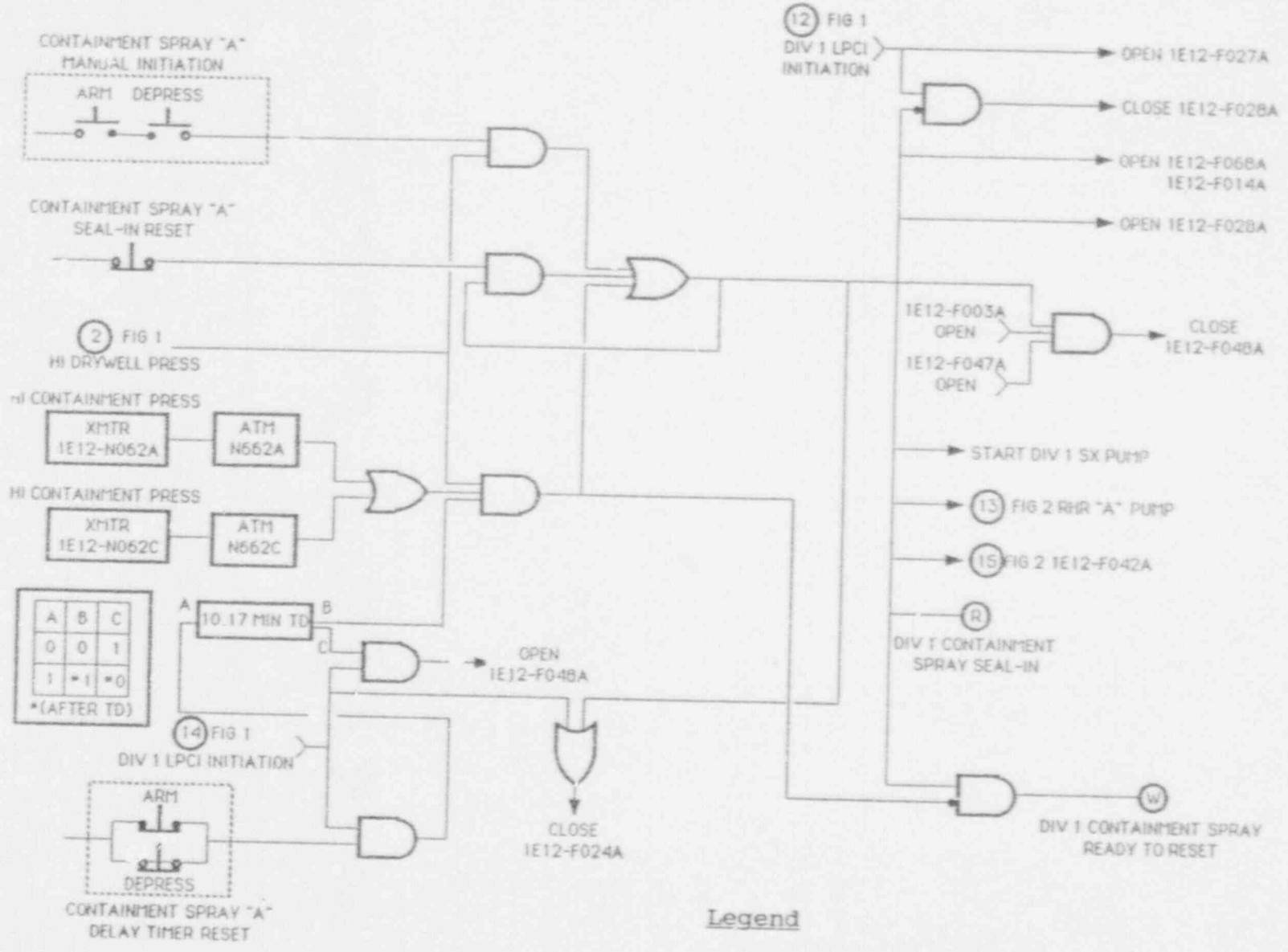

Legend

FIG 1 = Figure 3.2-5
 FIG 2 = Figure 3.2-6

Figure 3.2-7
 Division 1 Initiation Logic
 Sheet 3

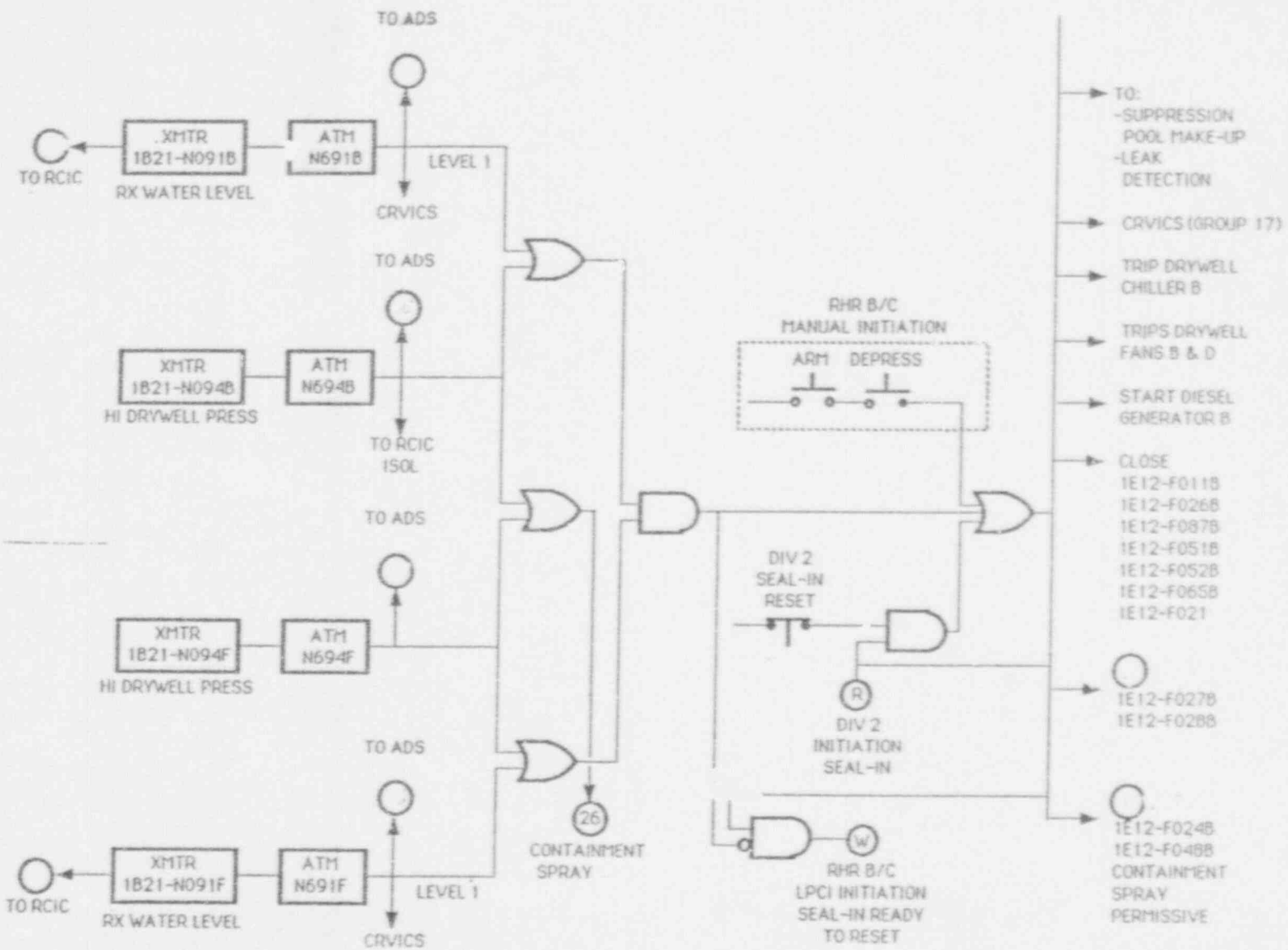

Figure 3.2-8
Division 2 Initiation Logic
Sheet 1

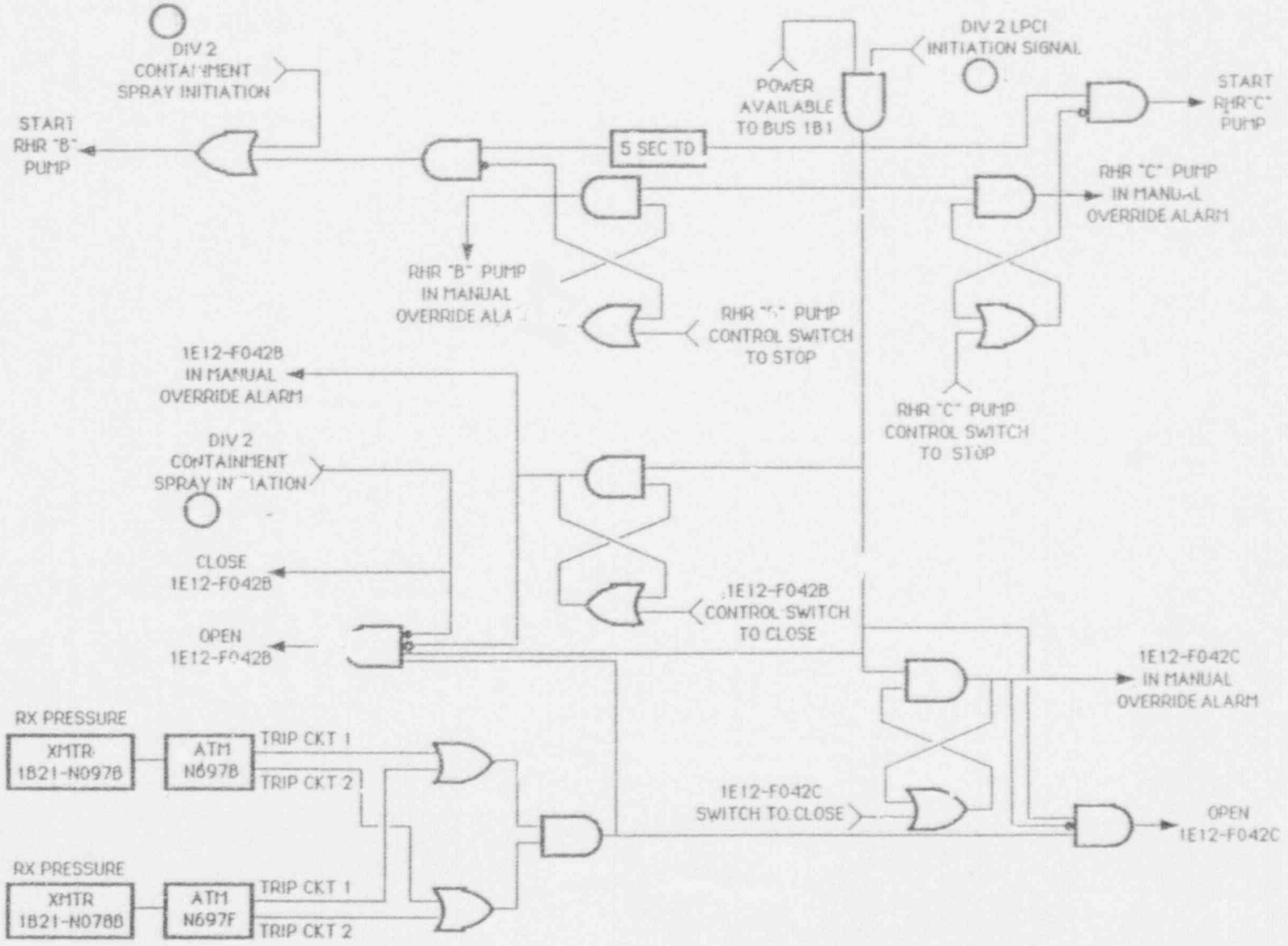

Figure 3.2-9
Division 2 Initiation Logic
Sheet 2

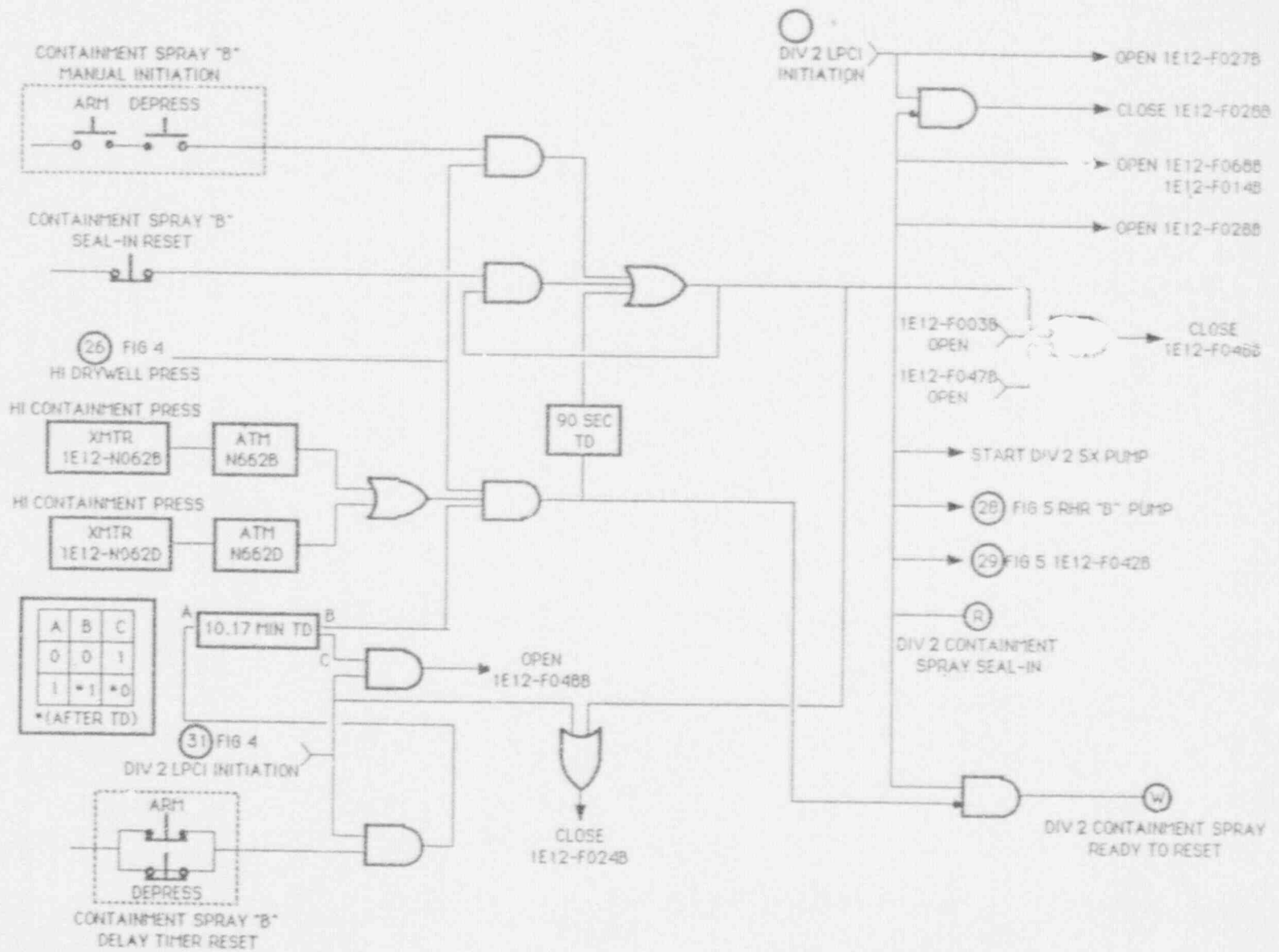

Figure 3.2-10
Division 2 Initiation Logic
Sheet 3

3-115

A	B	C
0	0	1
1	1	0

*(AFTER TD)

Figure 3.2-11
Divisions 3 and 4 Initiation Logic

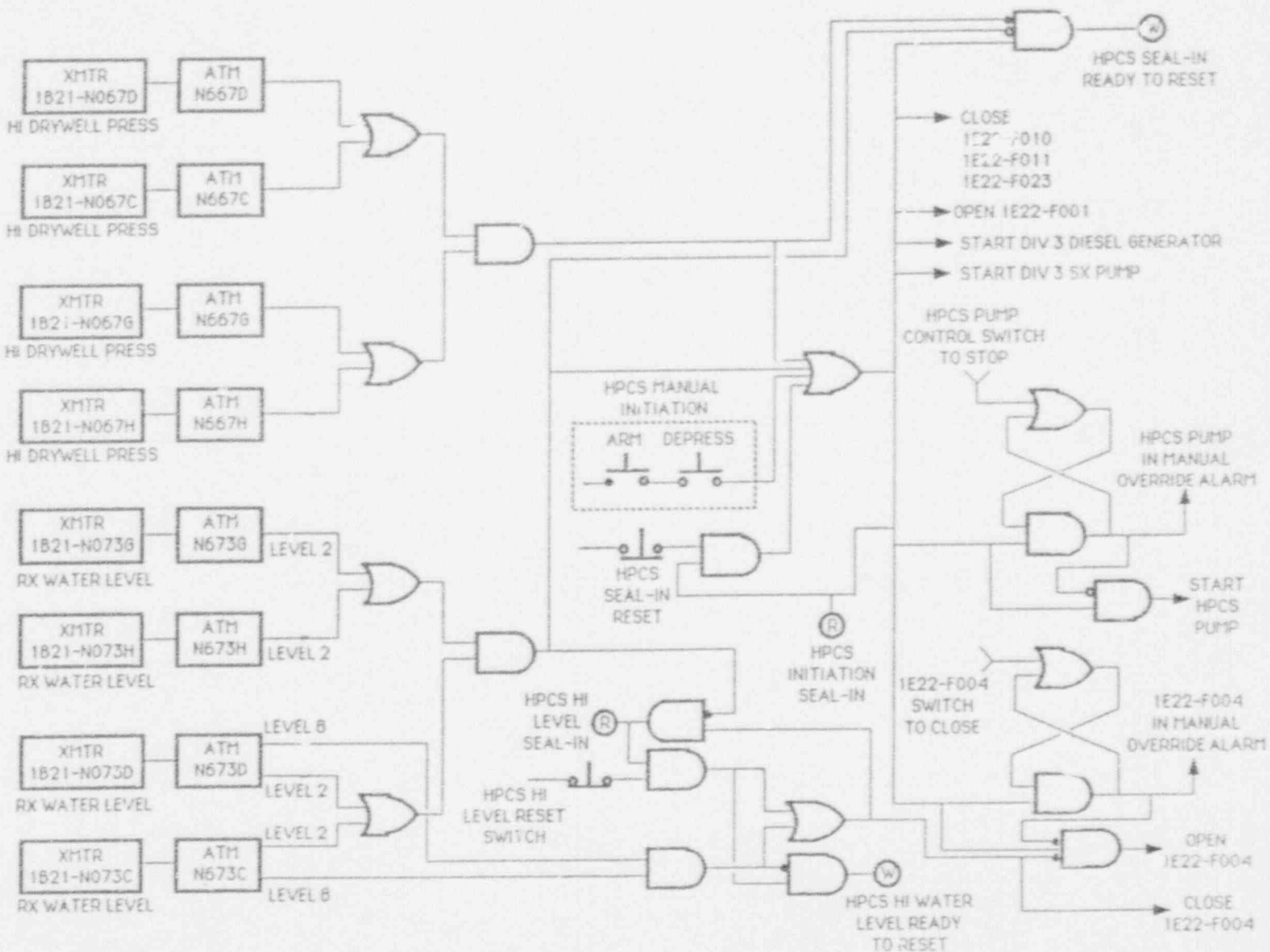

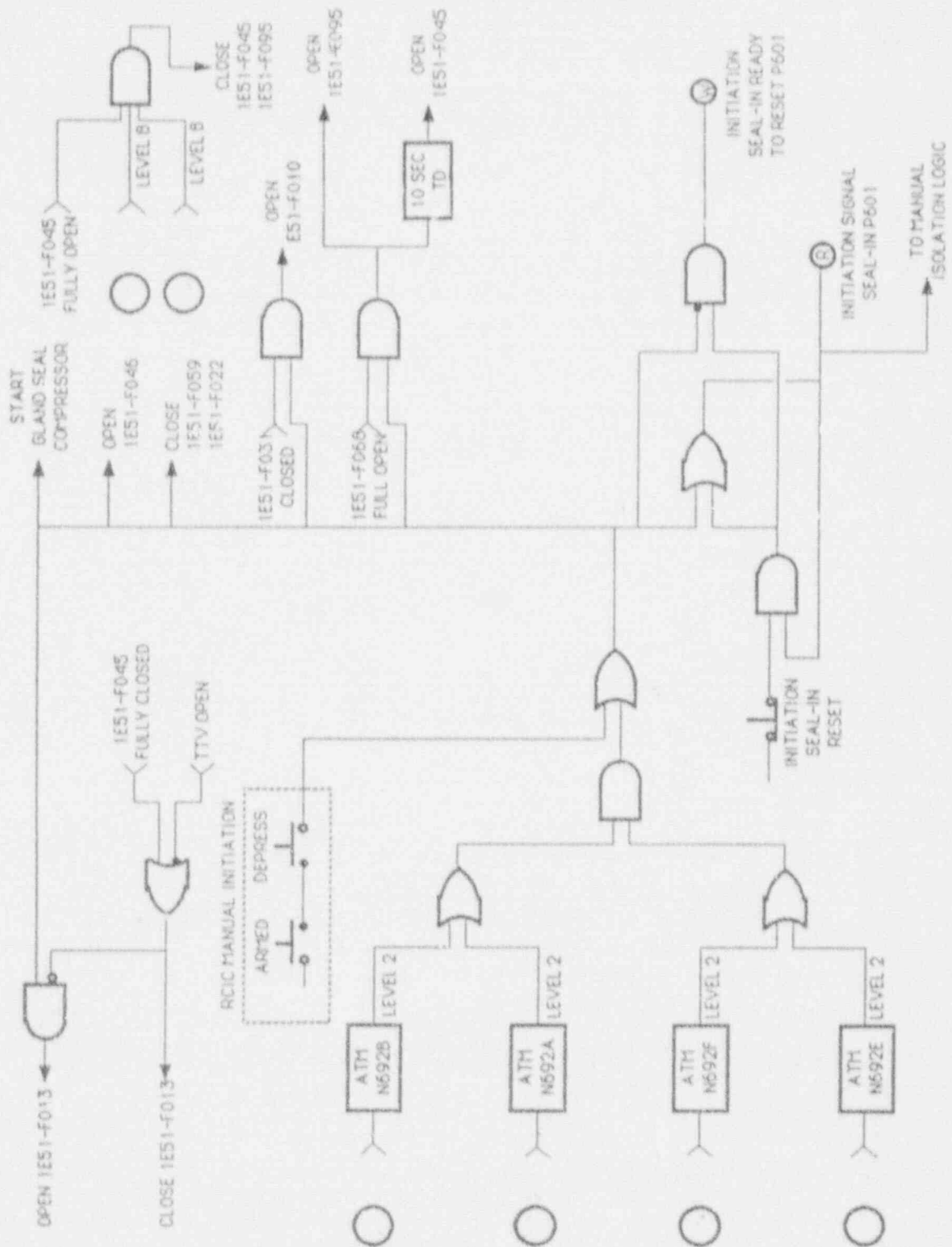

Figure 3.2-12
Reactor Core Isolation Cooling Initiation Logic

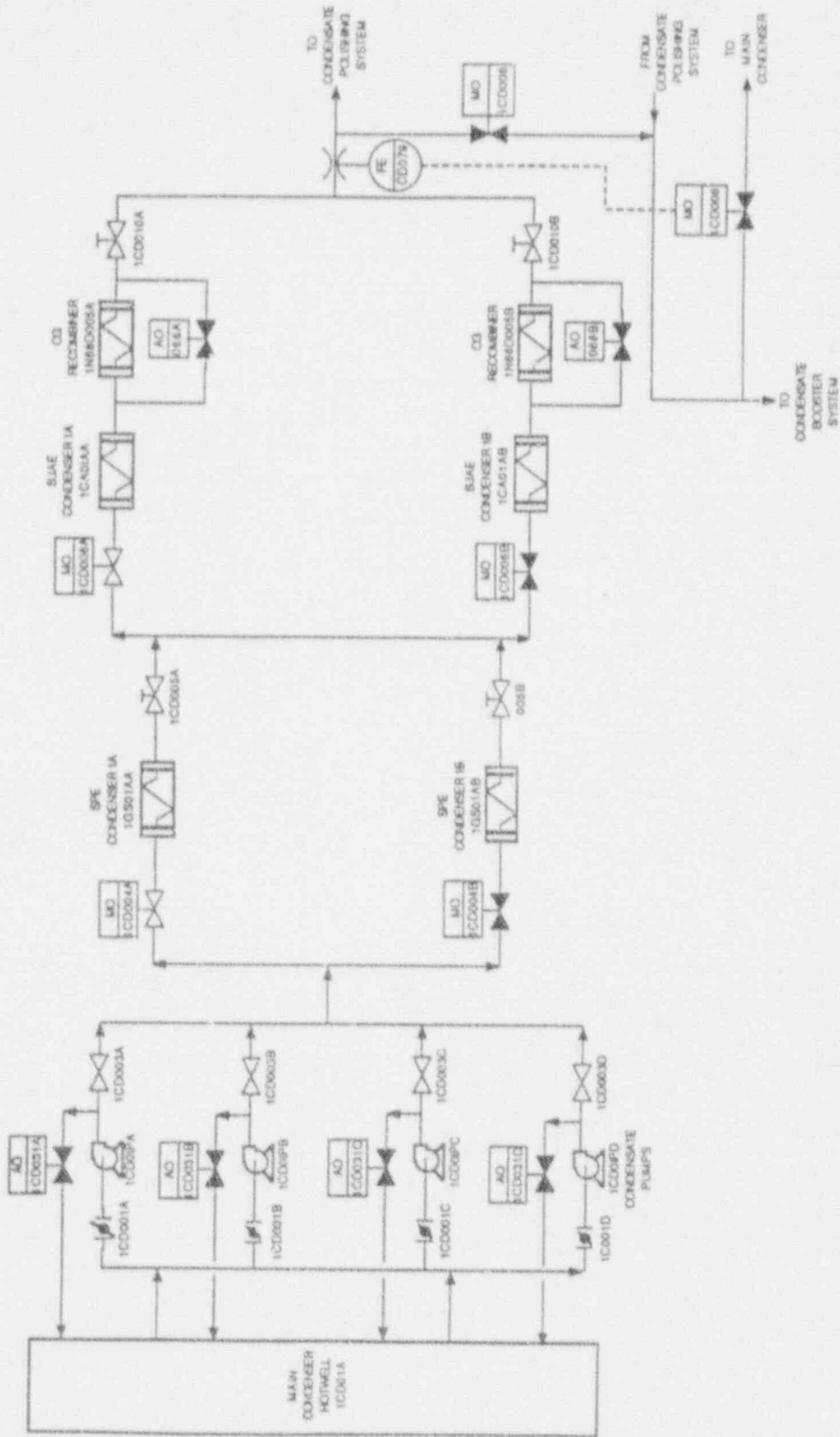

Figure 3.2-13
Condensate System

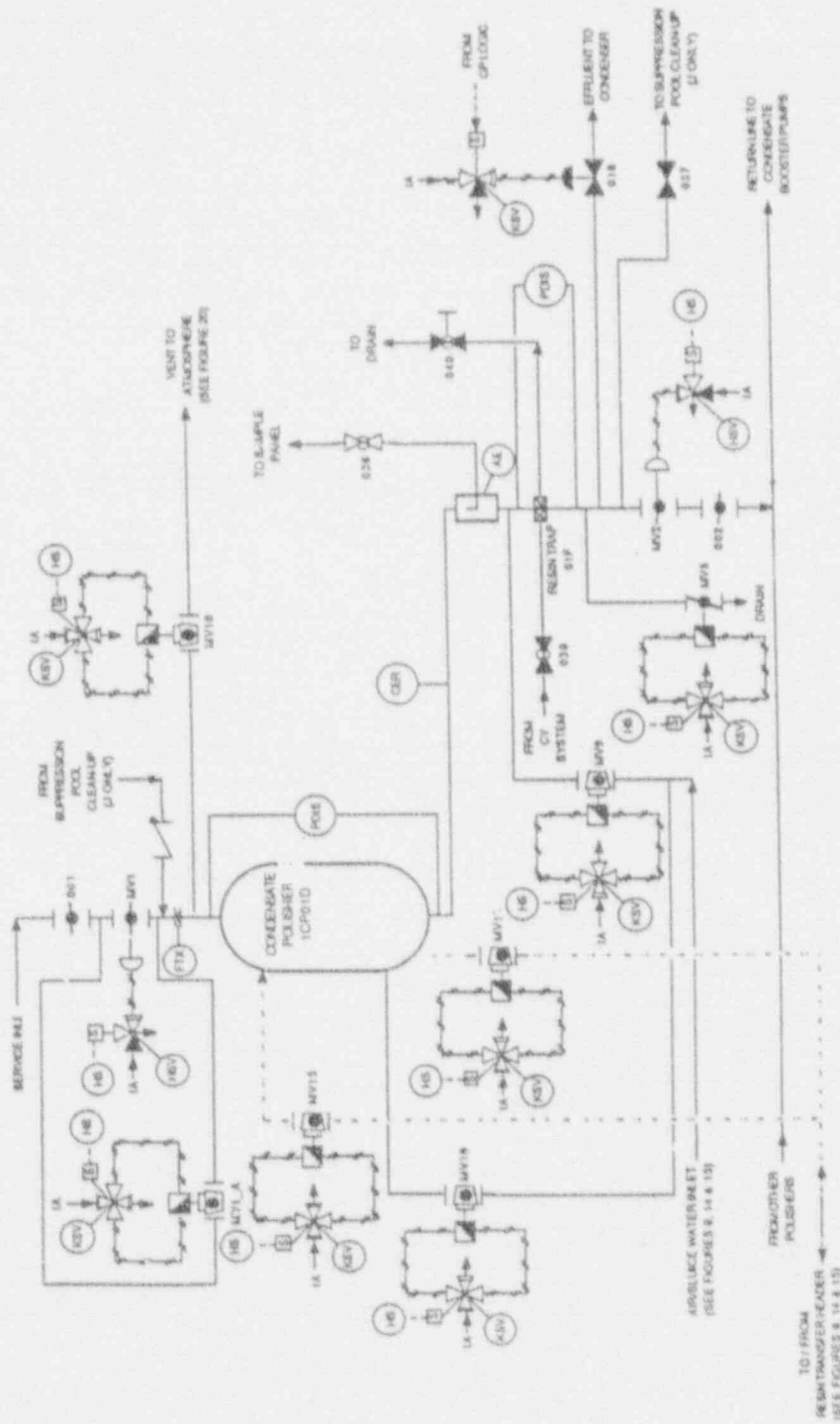

Figure 3.2-14
Condensate Polisher System

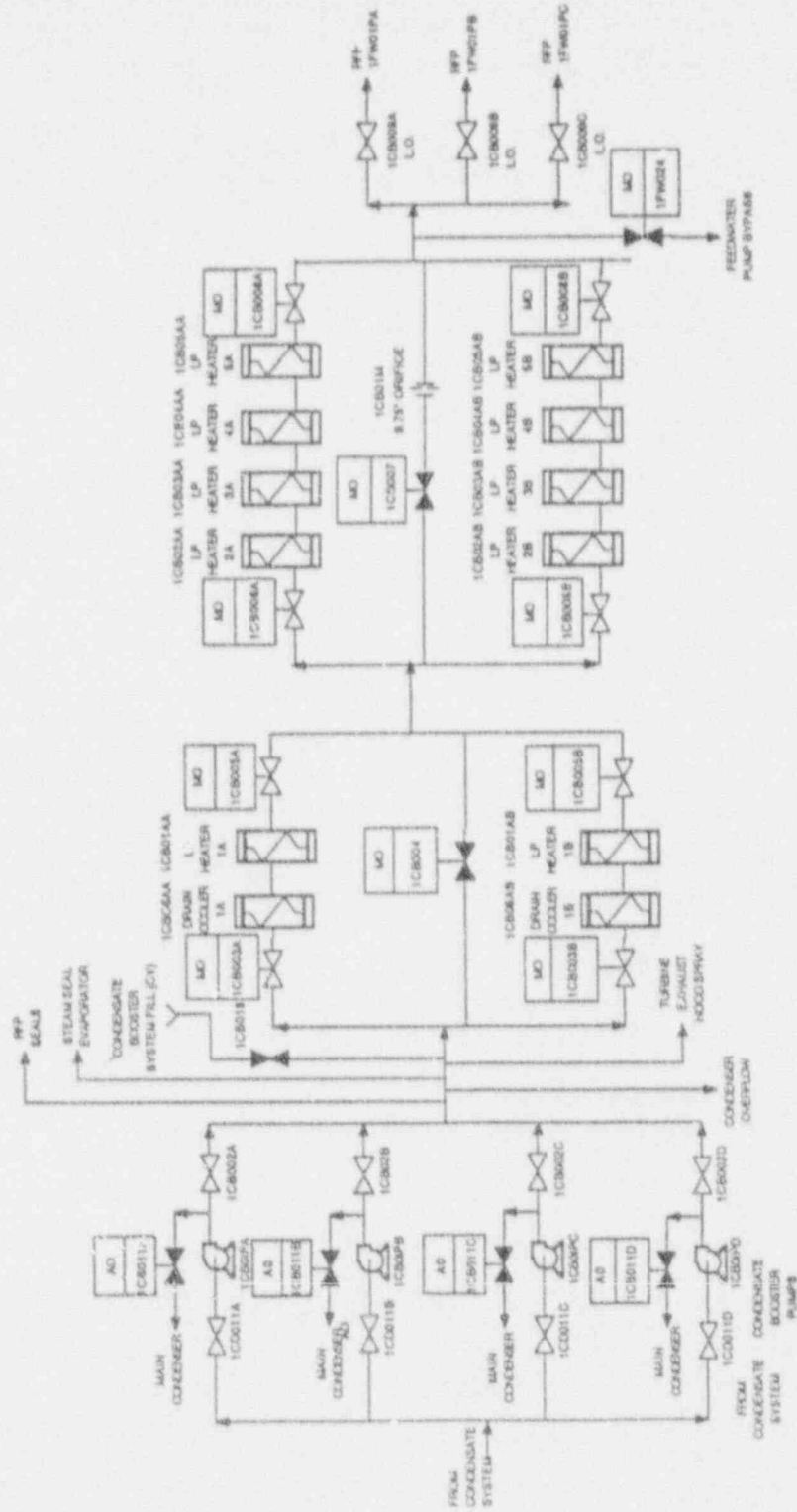

Figure 3.2-15
Condensate Booster System

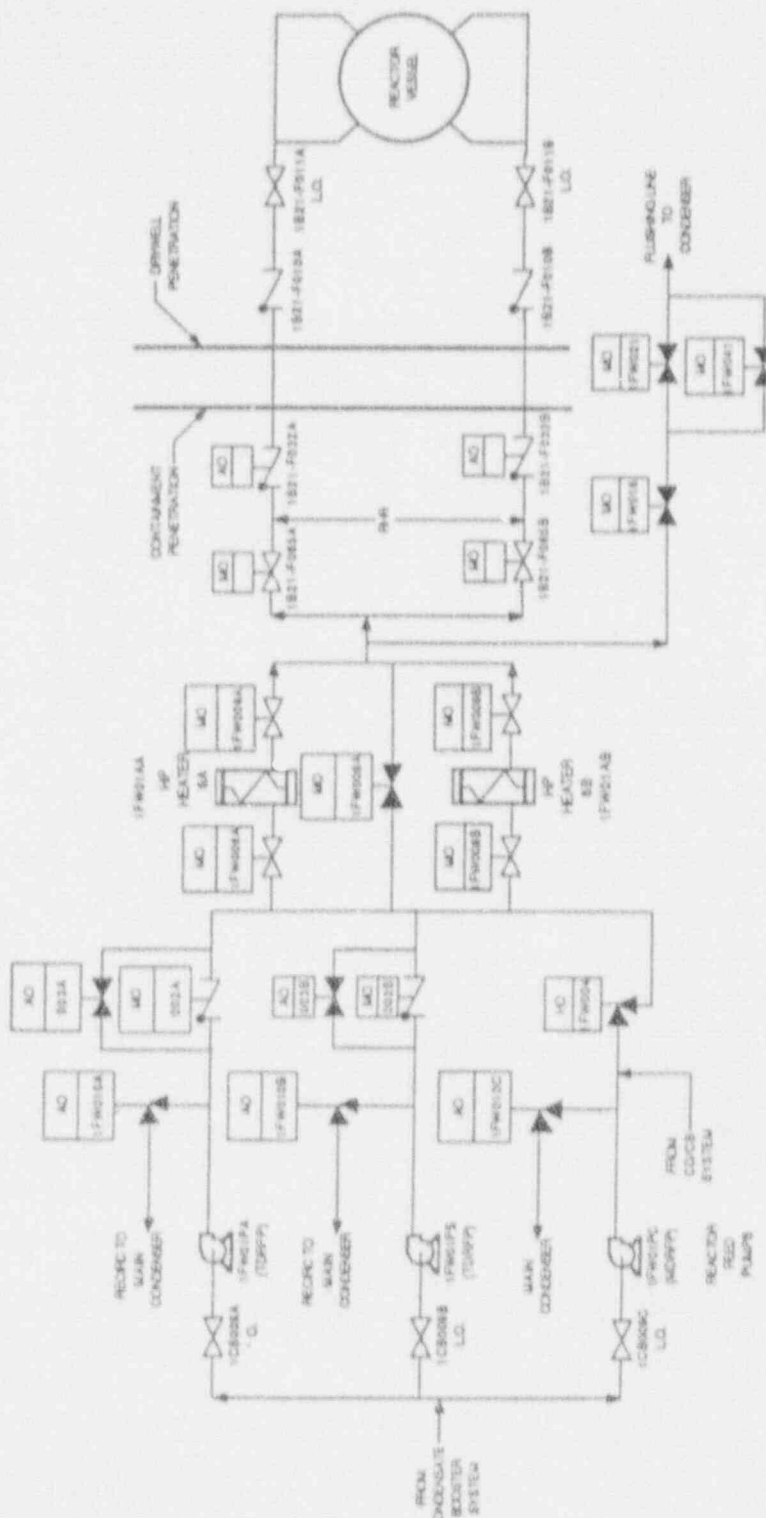

Figure 3.2-16
Feedwater System

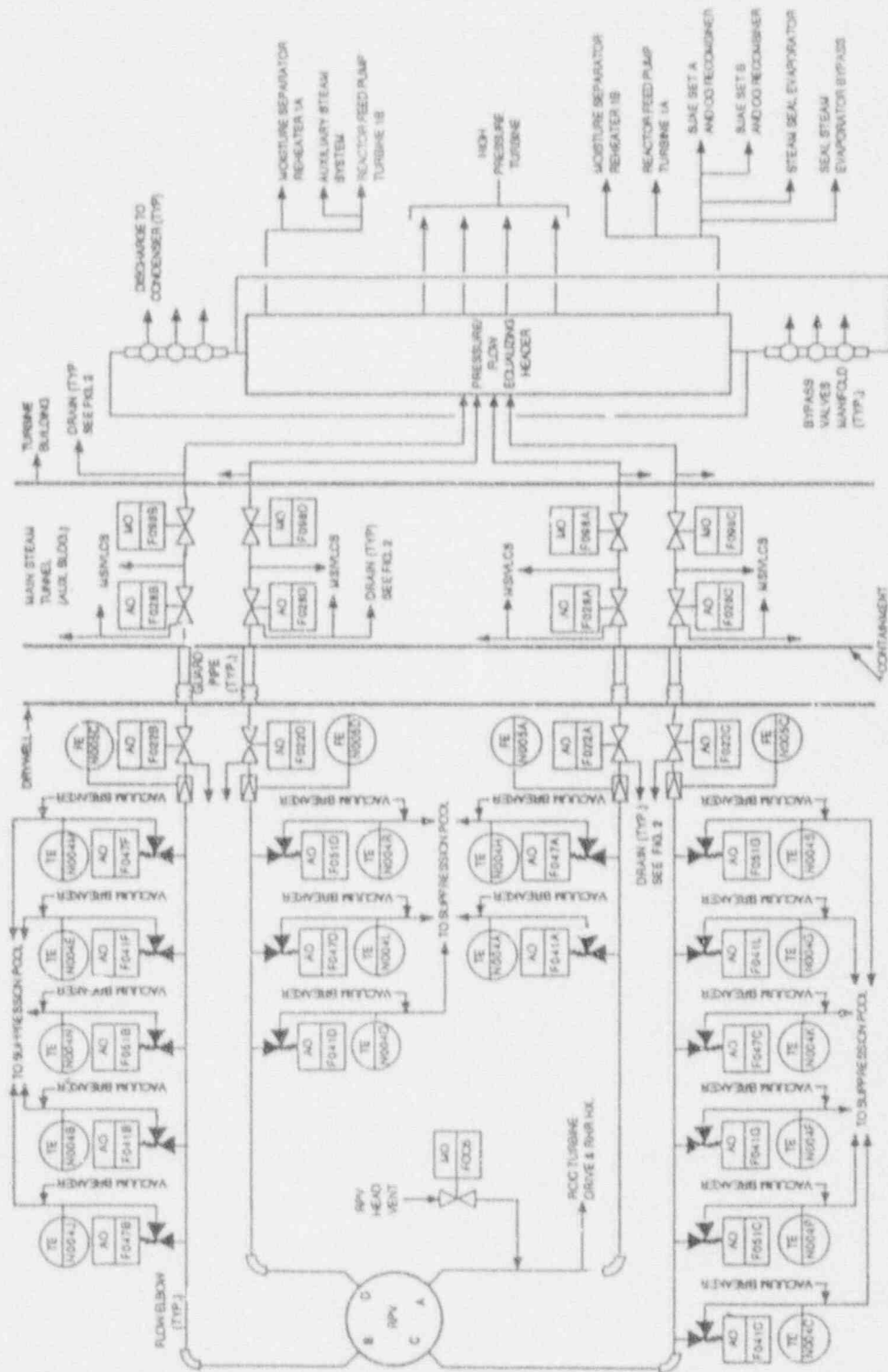

Figure 3.2-17
Main Steam System

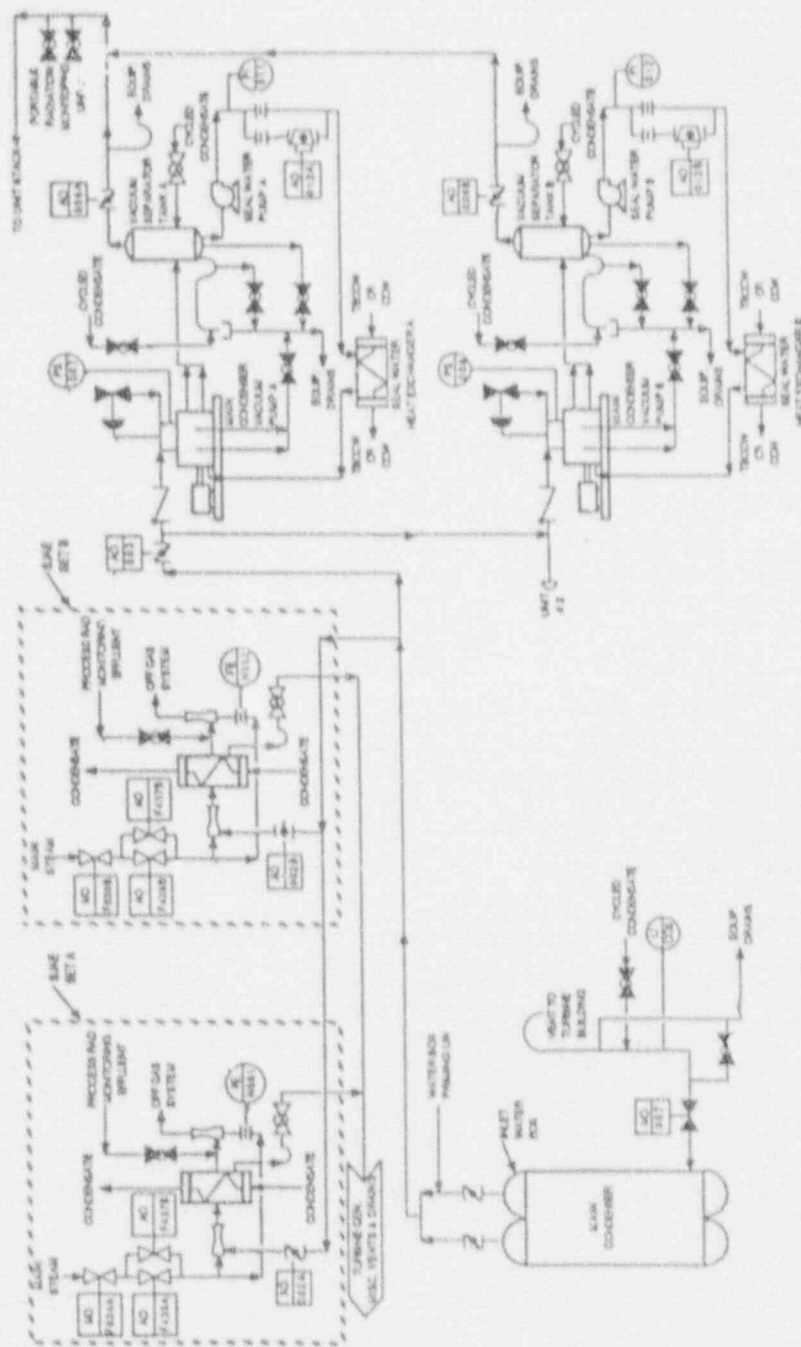

Figure 3.2-18
Condenser Air Removal System

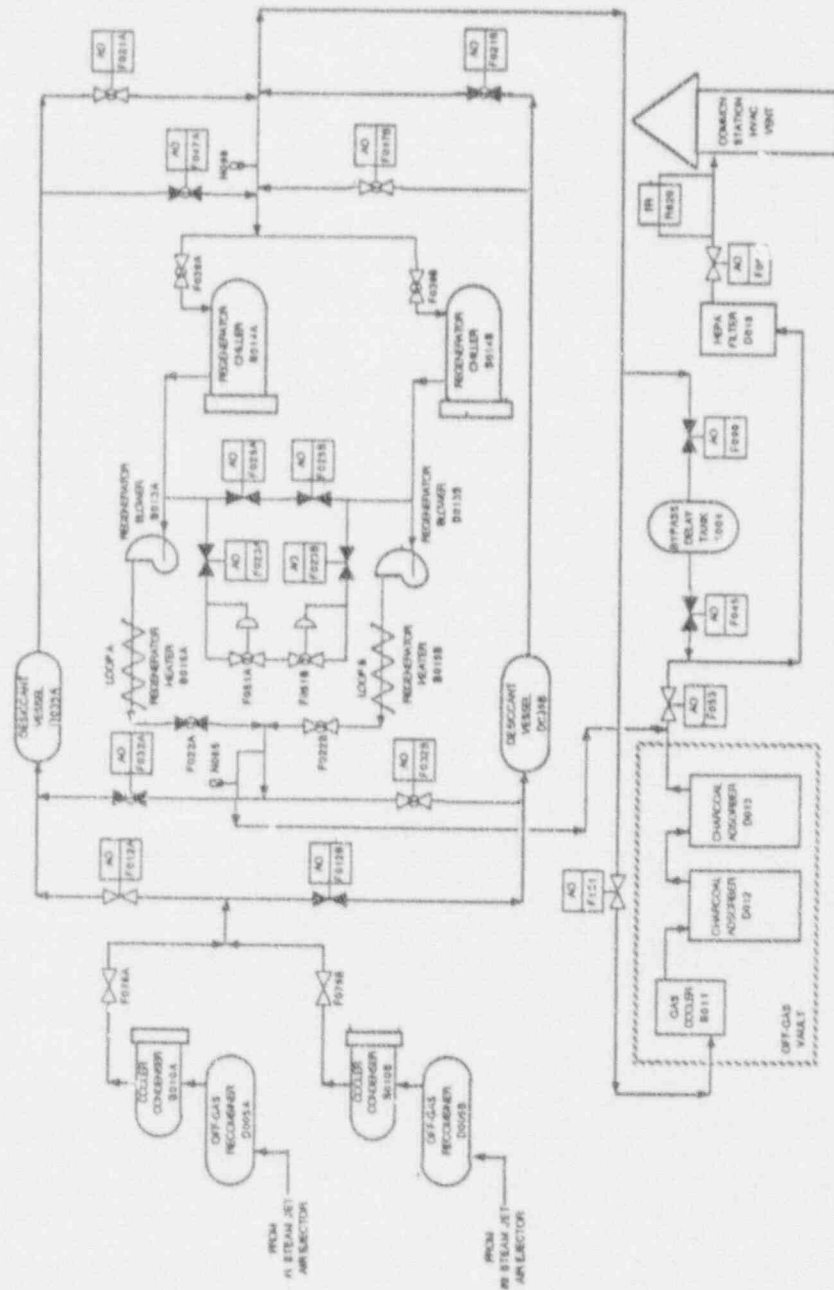

Figure 3.2-19
Off Gas System

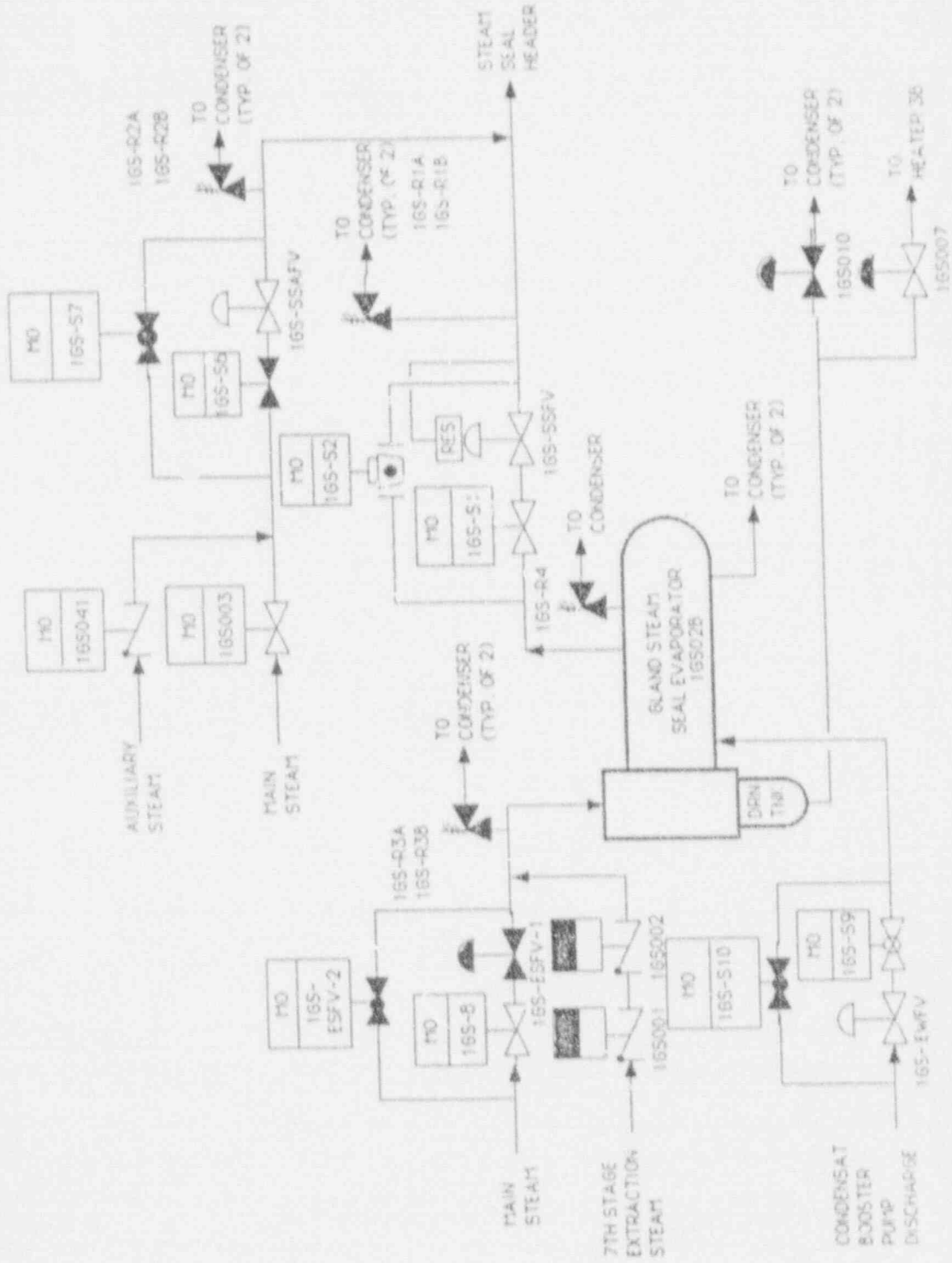

Figure 3.2-20
Gland Seal Steam System
Sheet 1

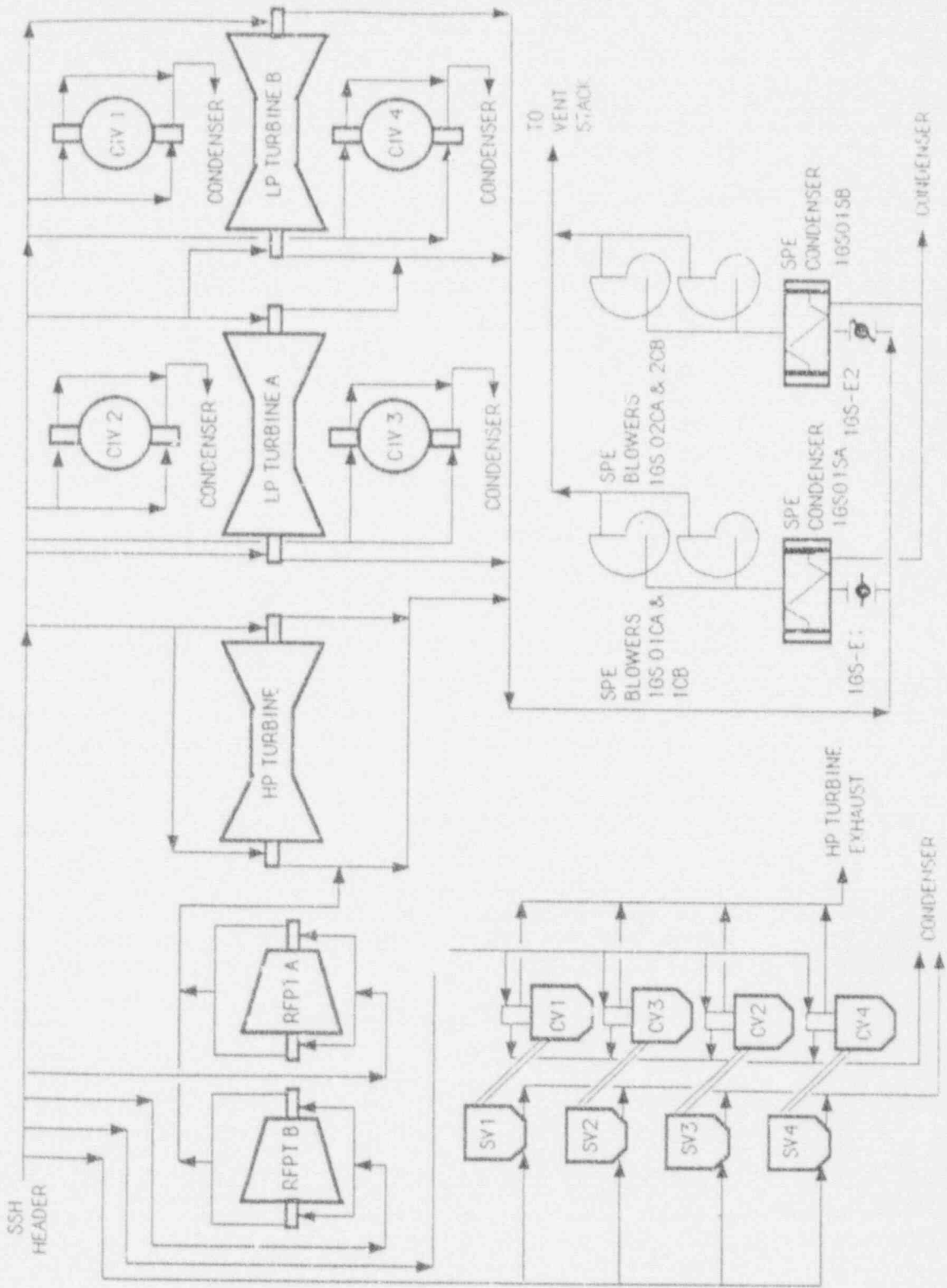
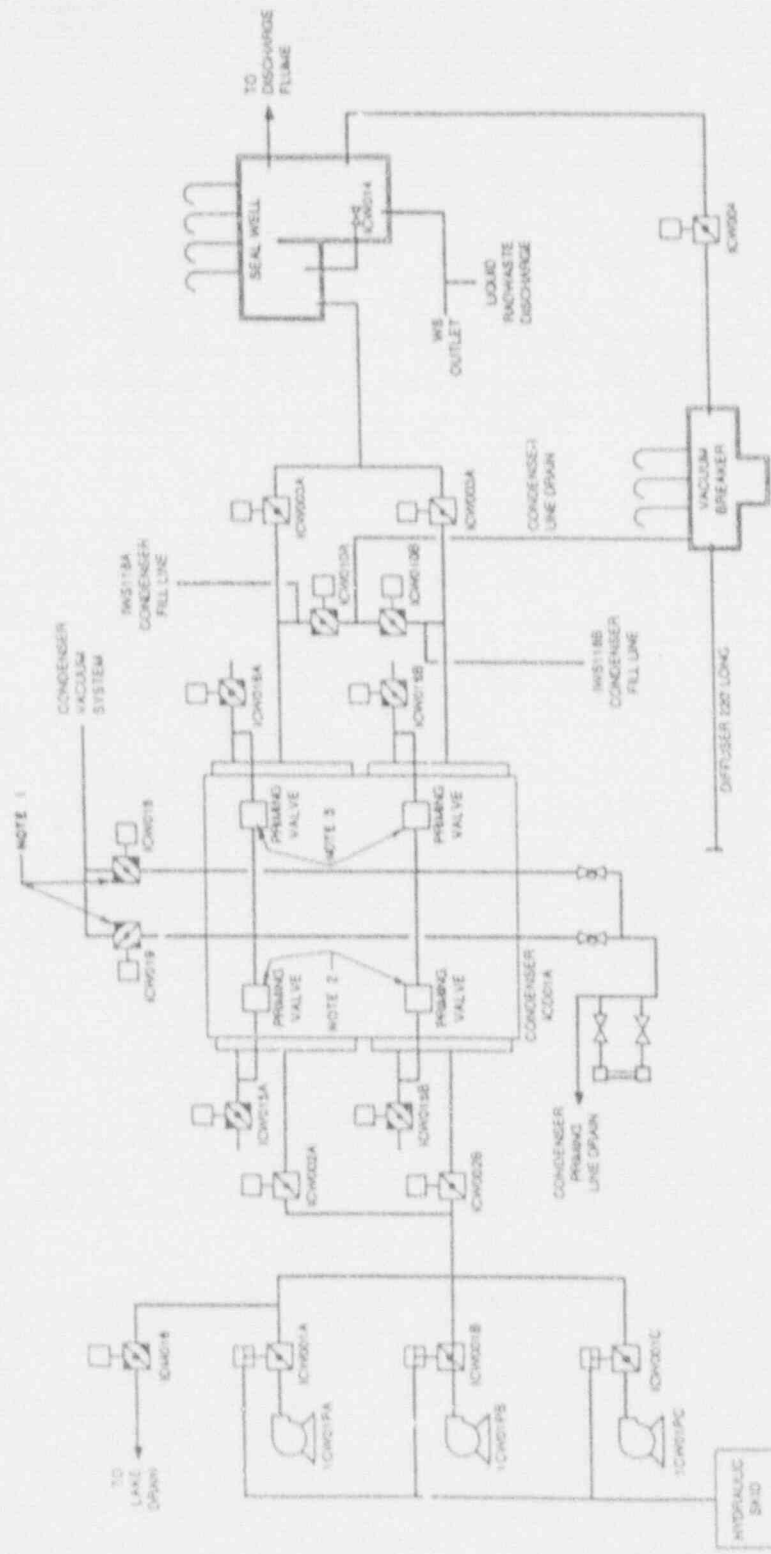

Figure 3.2-21
Gland Seal Steam System
Sheet 2



- NOTES
1. BLANK FLANGES INSTALLED ON WATER SIDE OF VALVES ICW018, 19.
 2. A BLANK FLANGE HAS BEEN INSTALLED ON EACH BOTH HALVES OF VALVES ICW010, B & C.
 3. VALVES ICW014, B HAVE OPERATING FLOAT INTERNALS REMOVED.

Figure 3.2-22
Circulating Water System

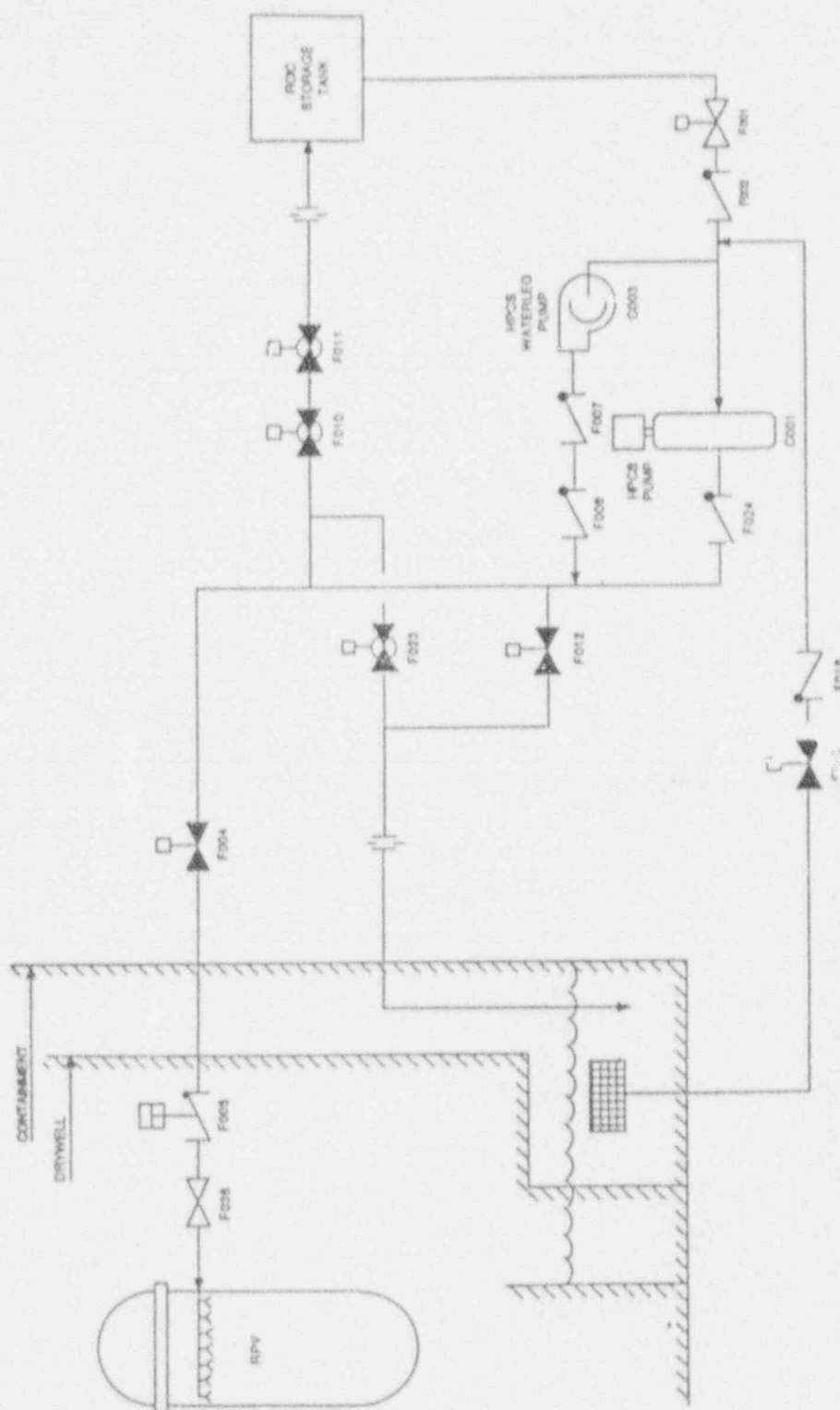

Figure 3.2-23
High Pressure Core Spray System

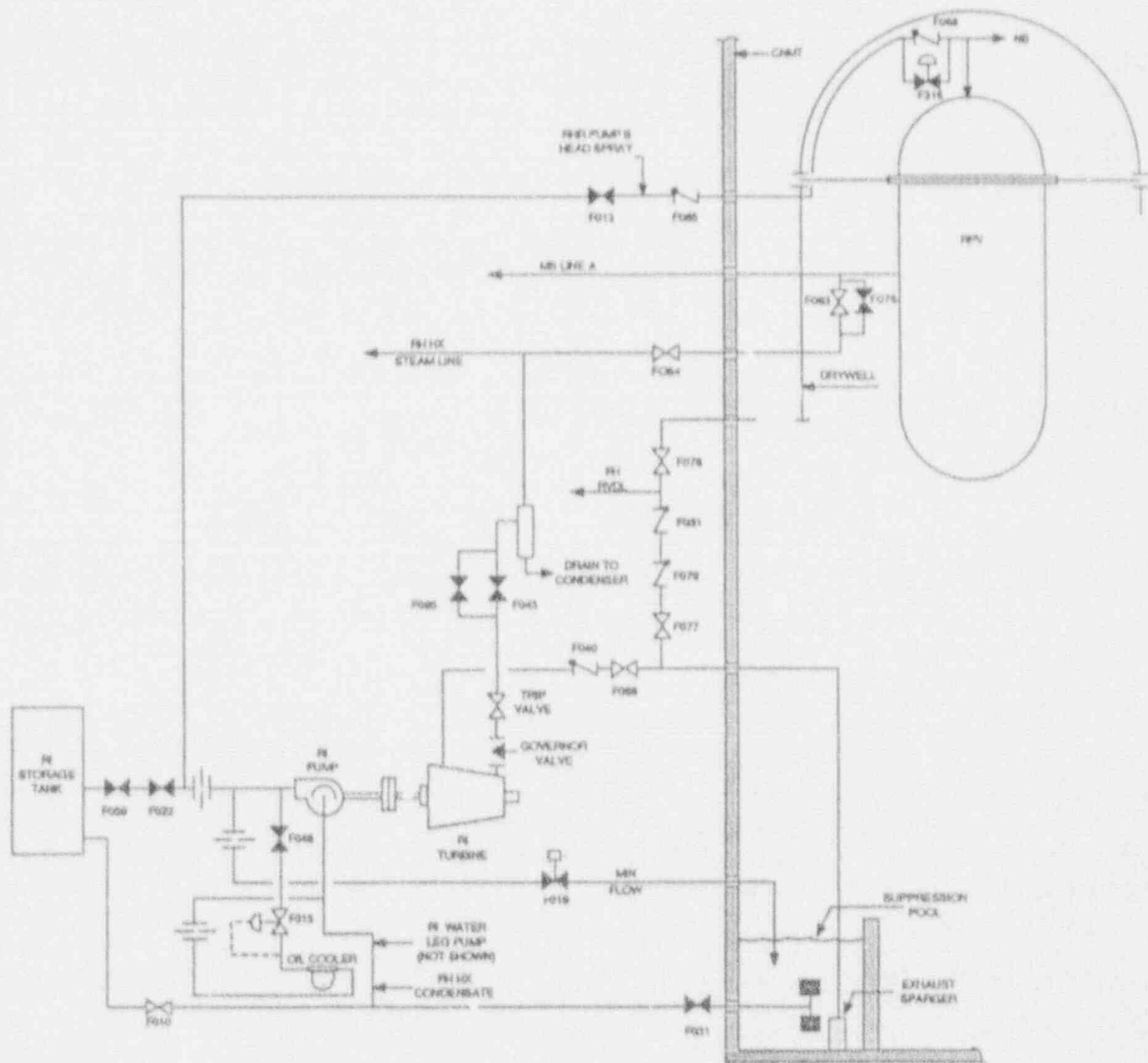

Figure 3.2-24
 Reactor Core Isolation Cooling System

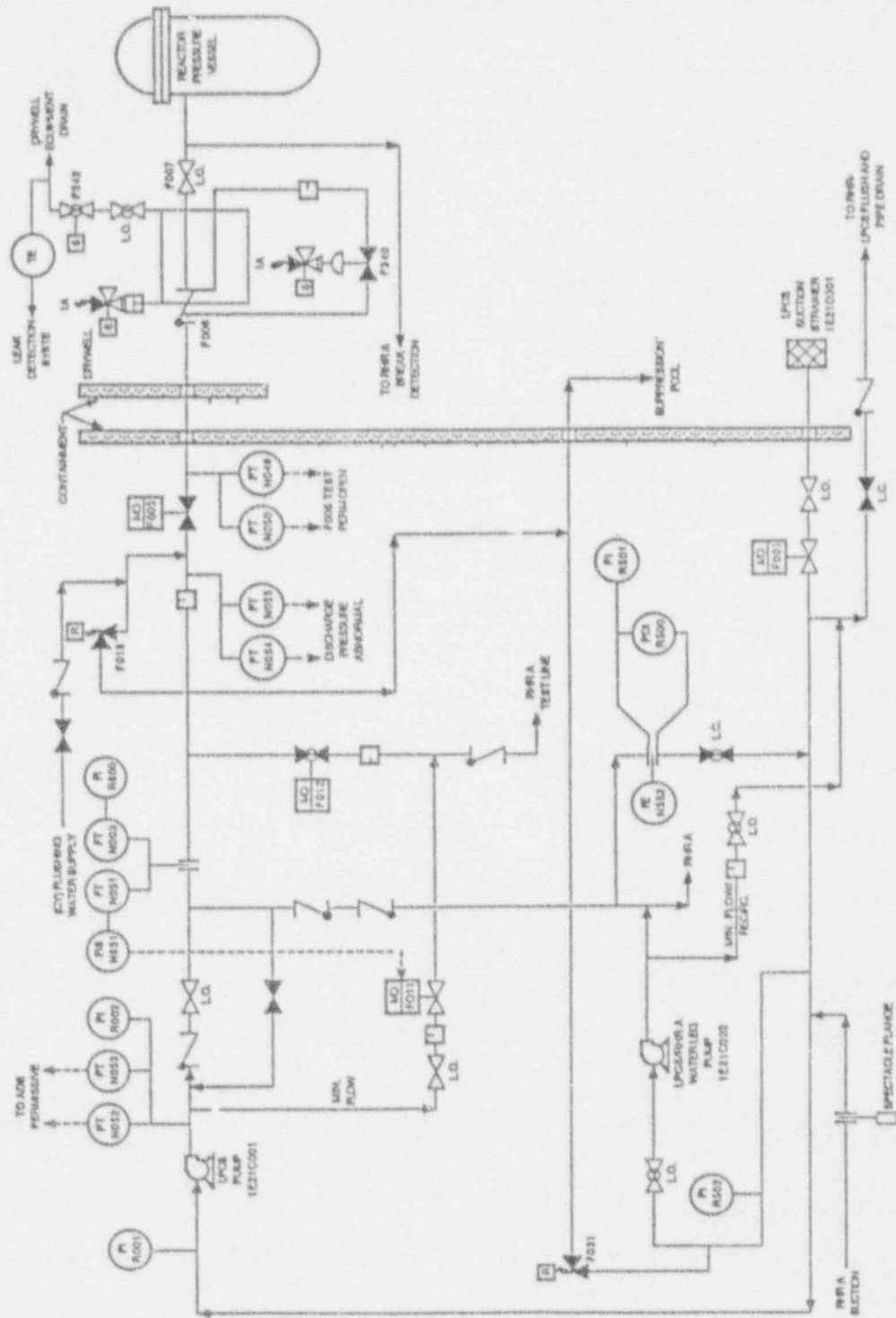

Figure 3.2-25
Low Pressure Core Spray System

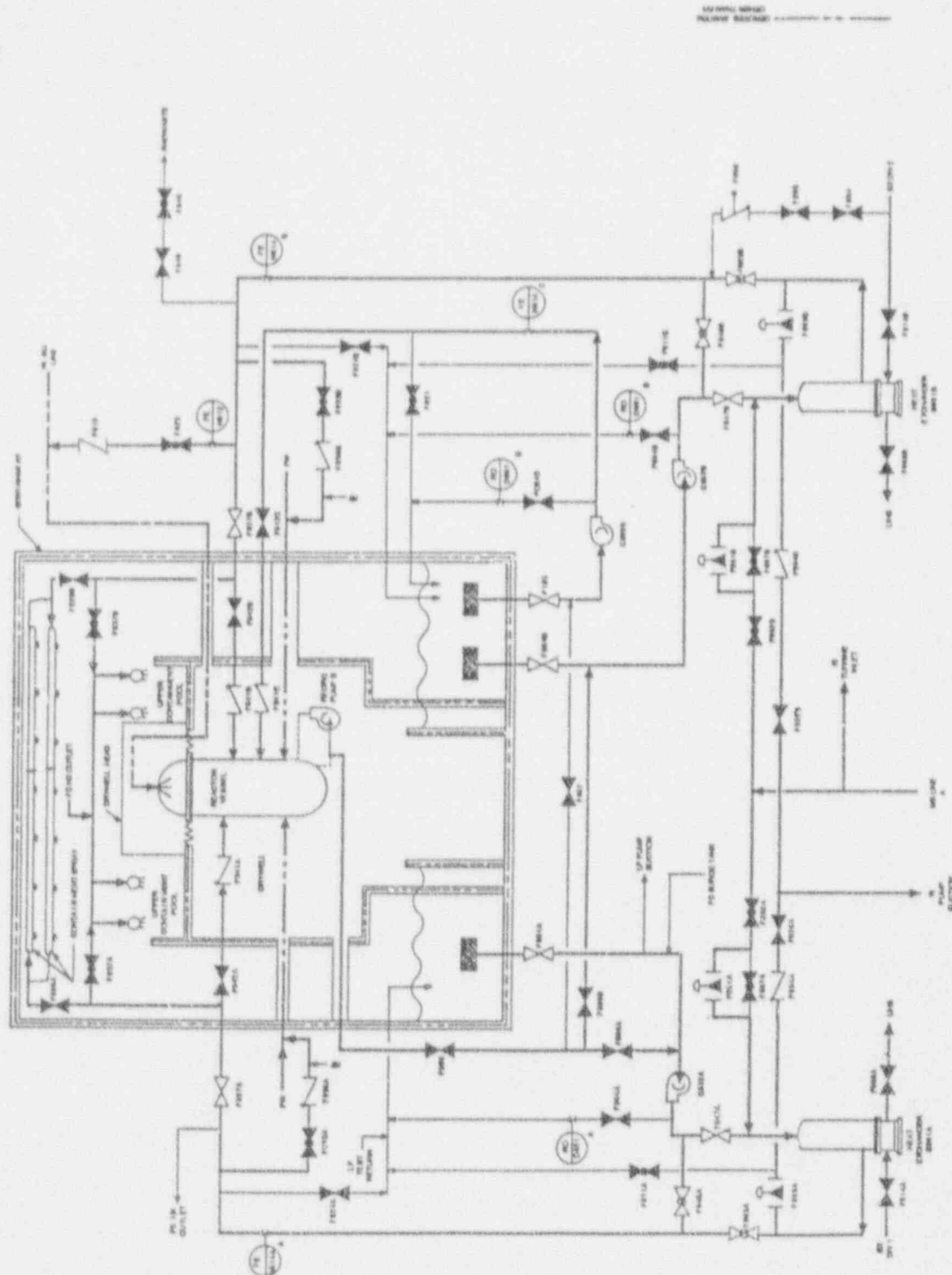

Figure 3.2-26
Residual Heat Removal System

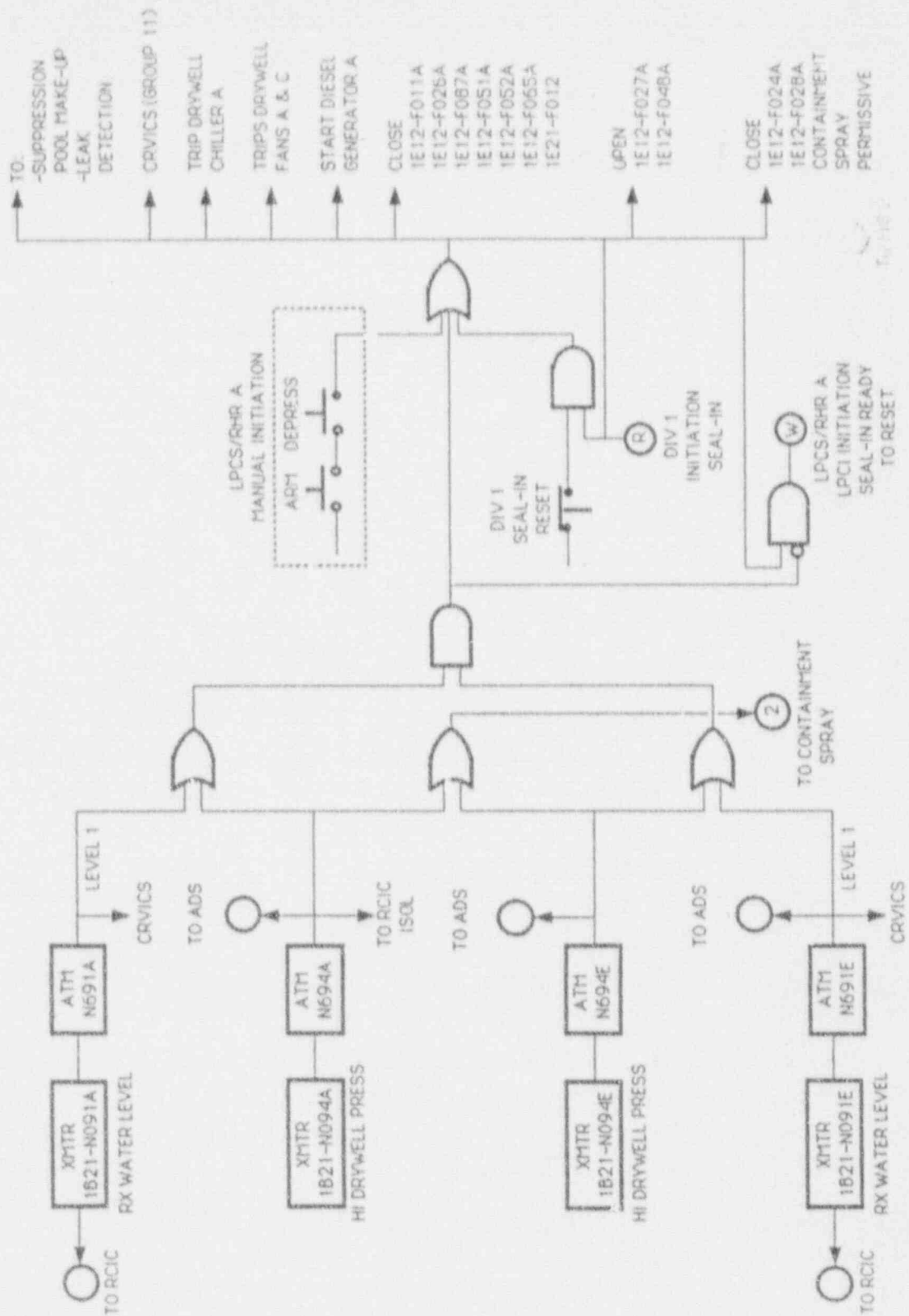

Figure 3.2-27
Engineered Safety Feature
Actuation Logic

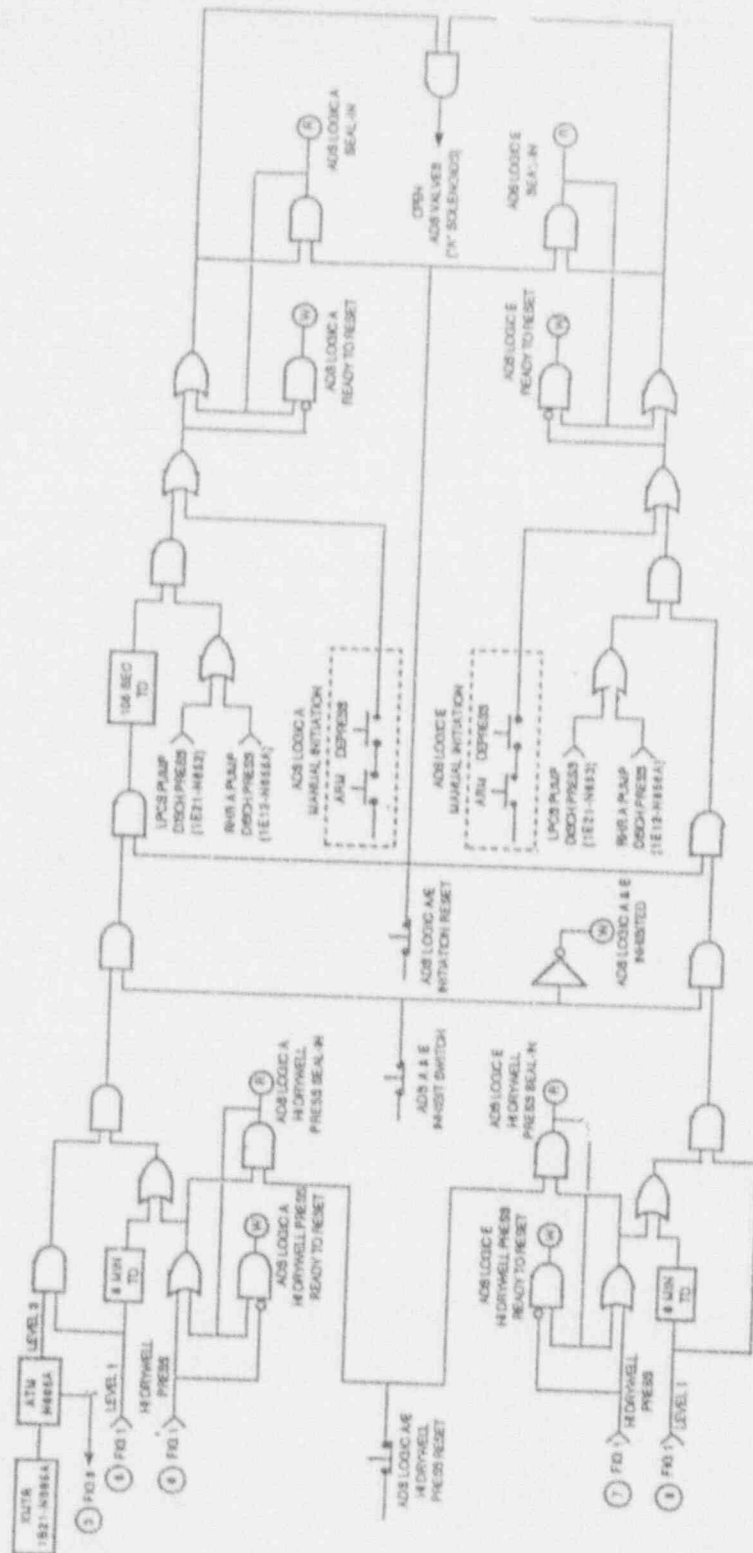

Figure 3.2-28
 ADS Actuation Logic
 (Total of 2)

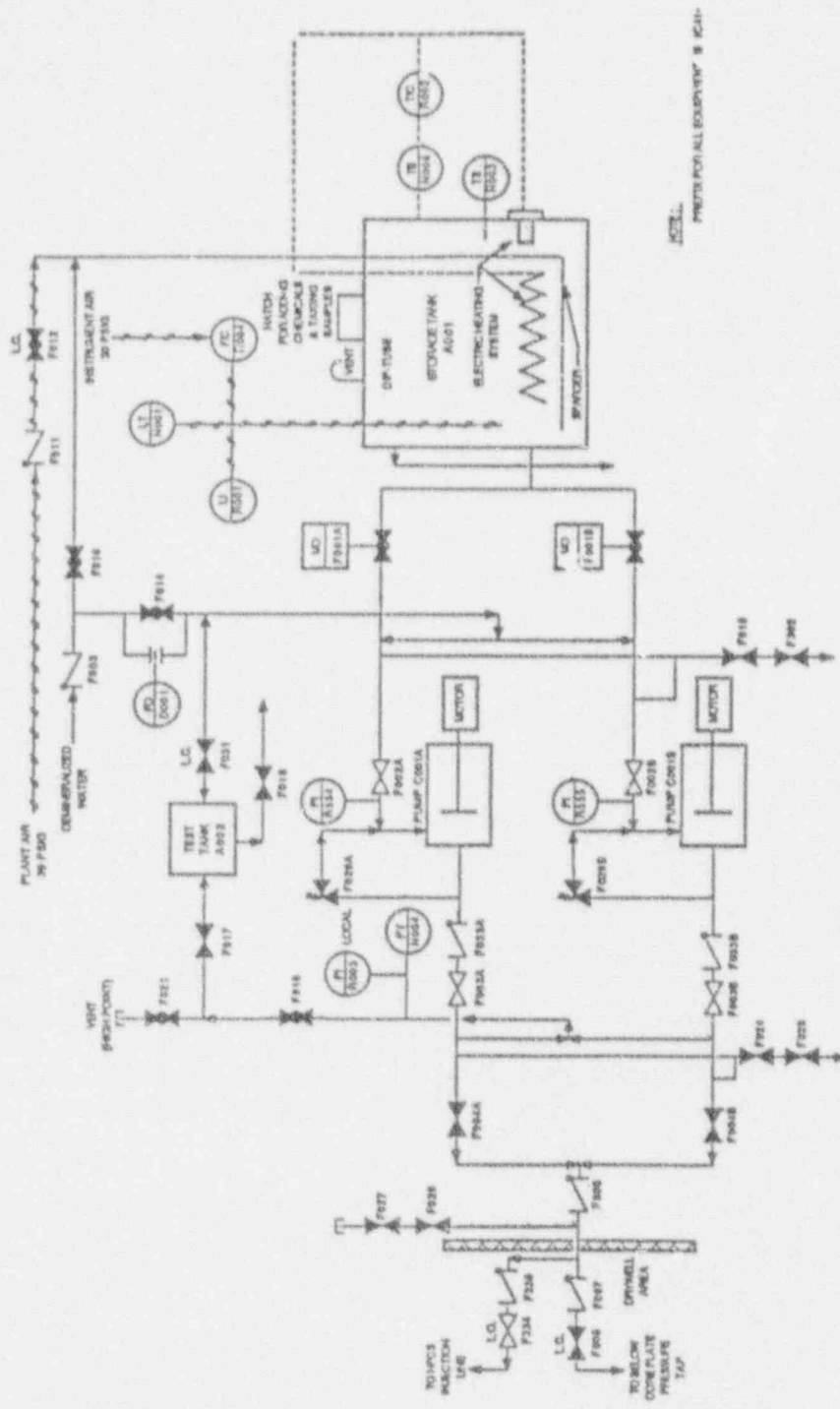

Figure 3.2-29
Standby Liquid Control System

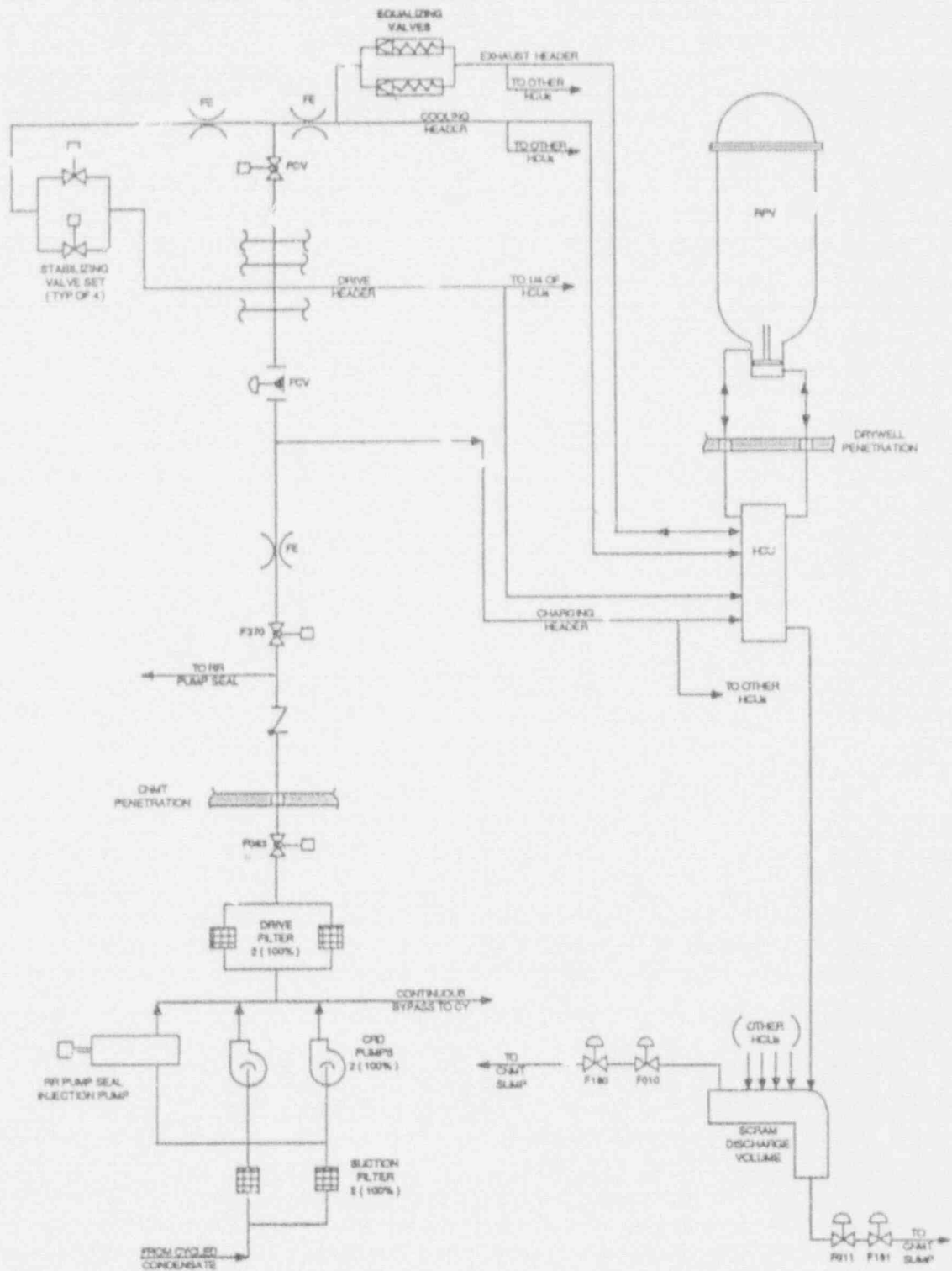

Figure 3.2-30
Control Rod Drive System

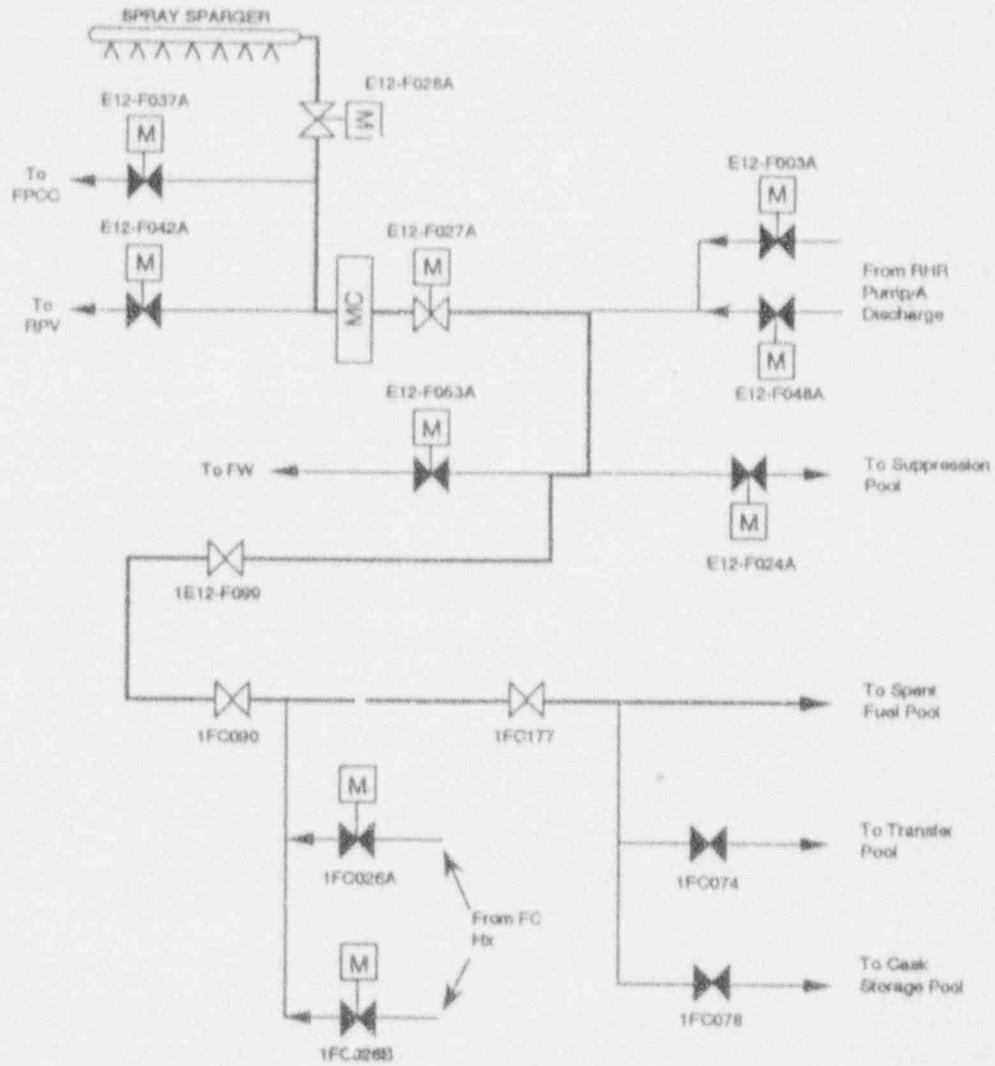

Figure 3.2-31
Containment Venting to Spent
Fuel Storage Pool

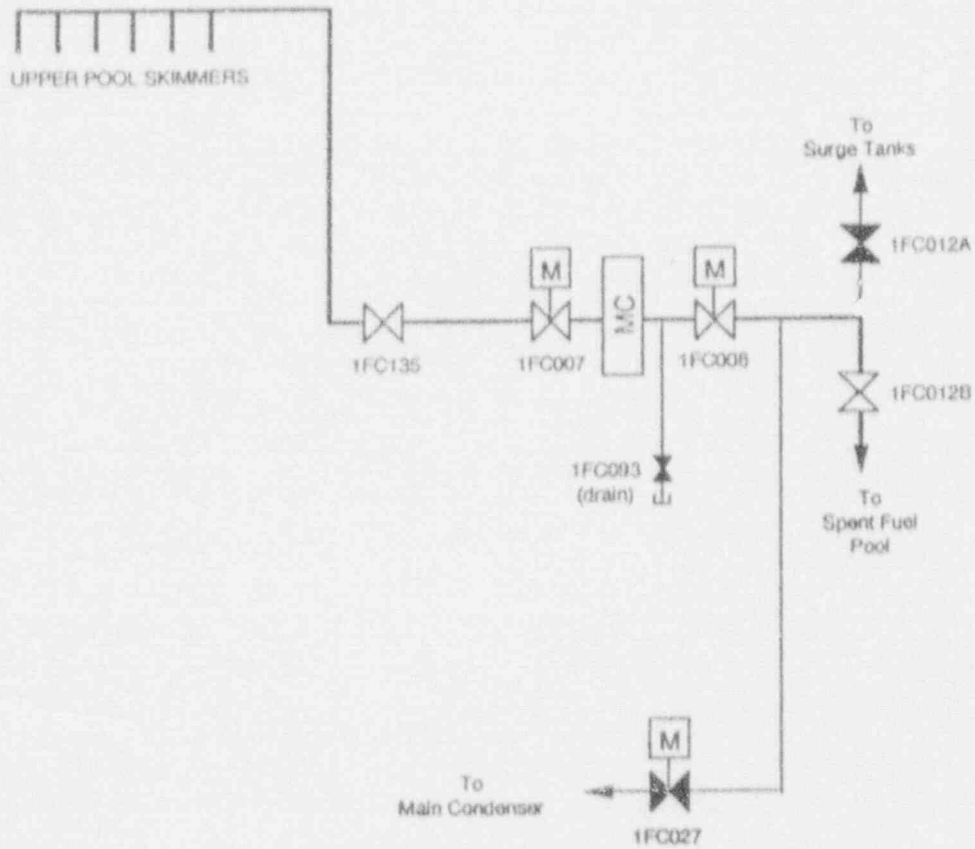

Figure 3.2-32
Containment Venting To
Spent Fuel Storage Pool

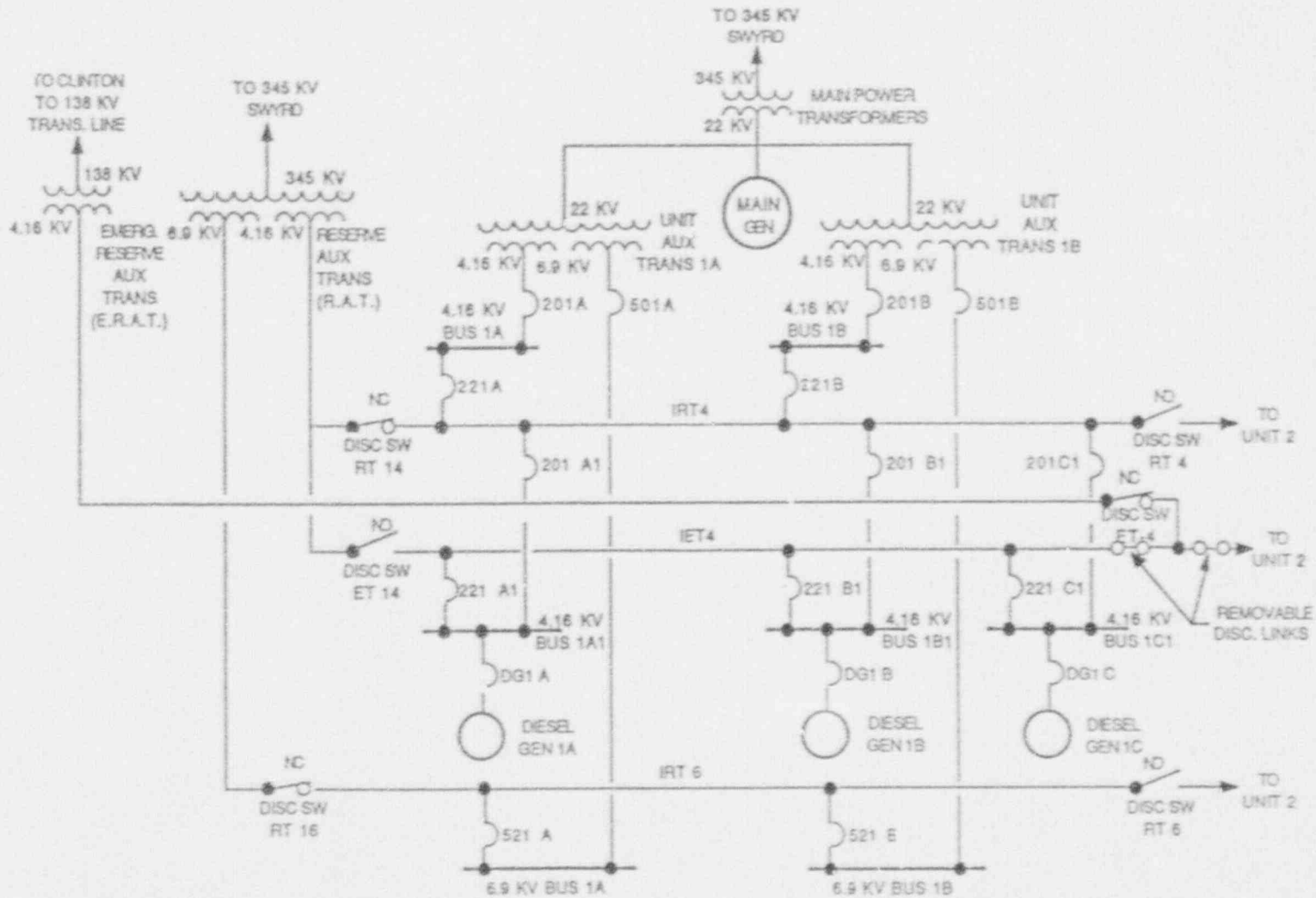

Figure 3.2-33
Auxiliary Power System
Sheet 1

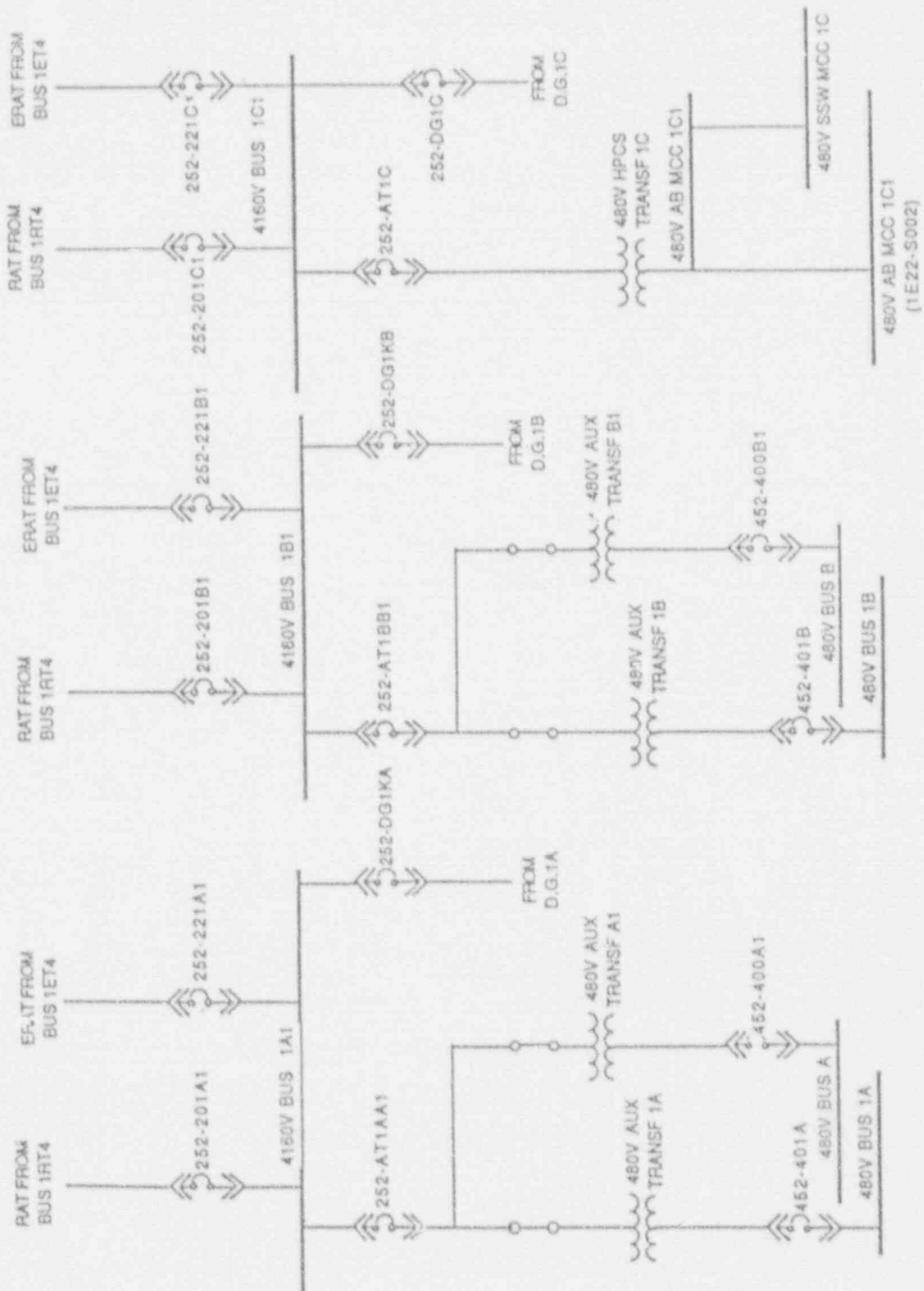

Figure 3.2-34
 Auxiliary Power System
 Sheet 2

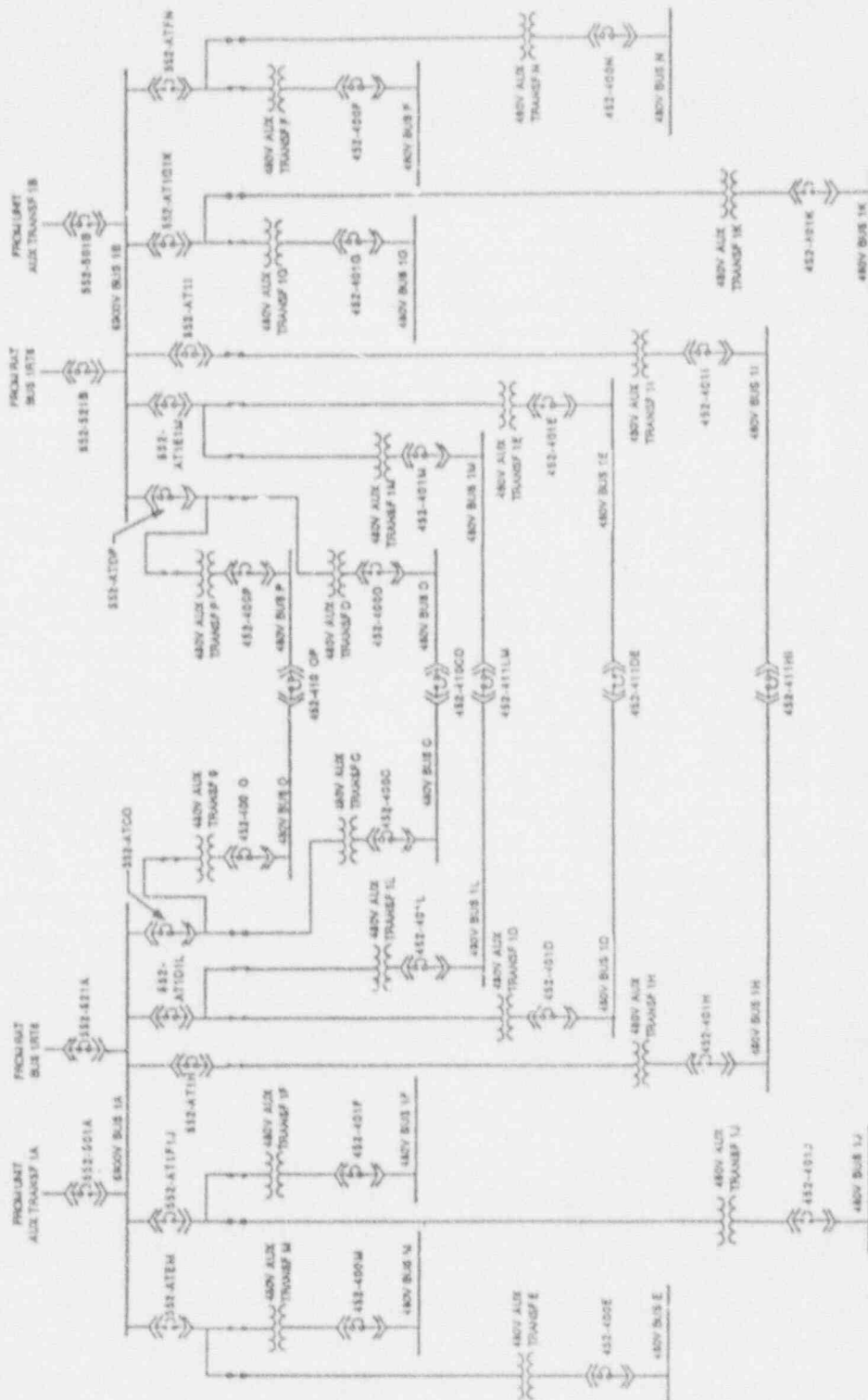

Figure 3.2-35
 Auxiliary Power System
 Sheet 3

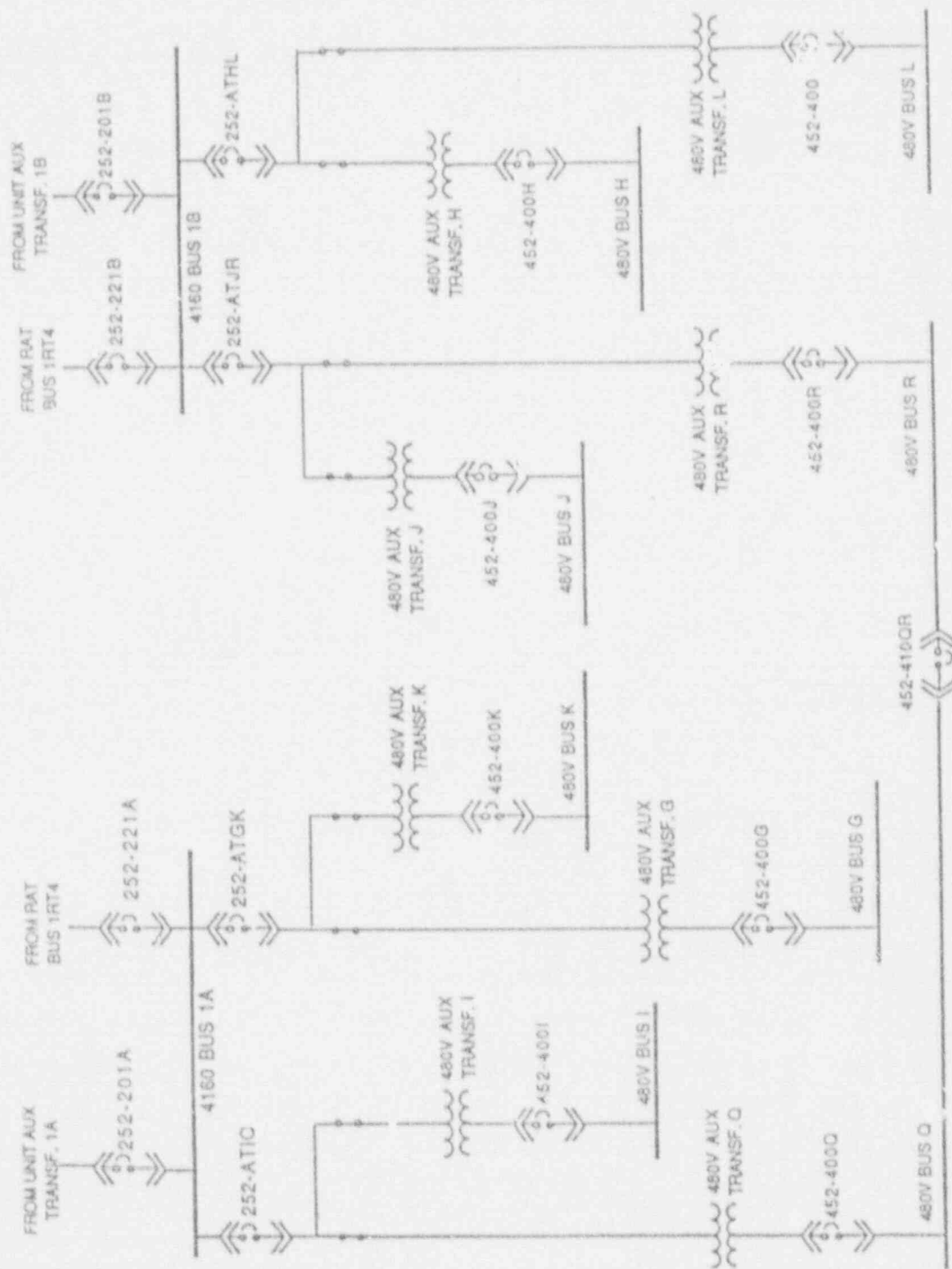

Figure 3.2-36
Auxiliary Power System
Sheet 4

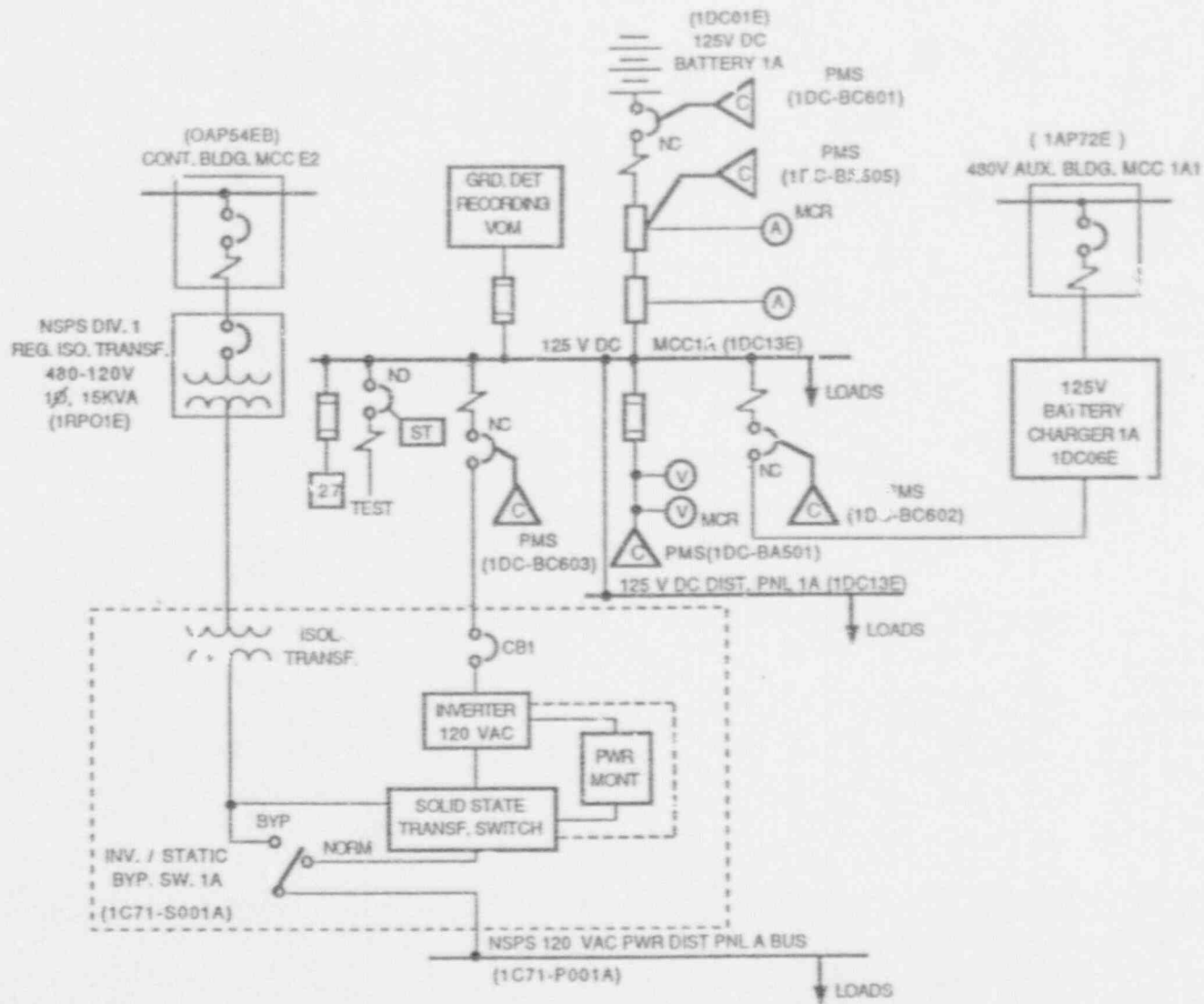

Figure 3.2-37
Division 1 DC Distribution System

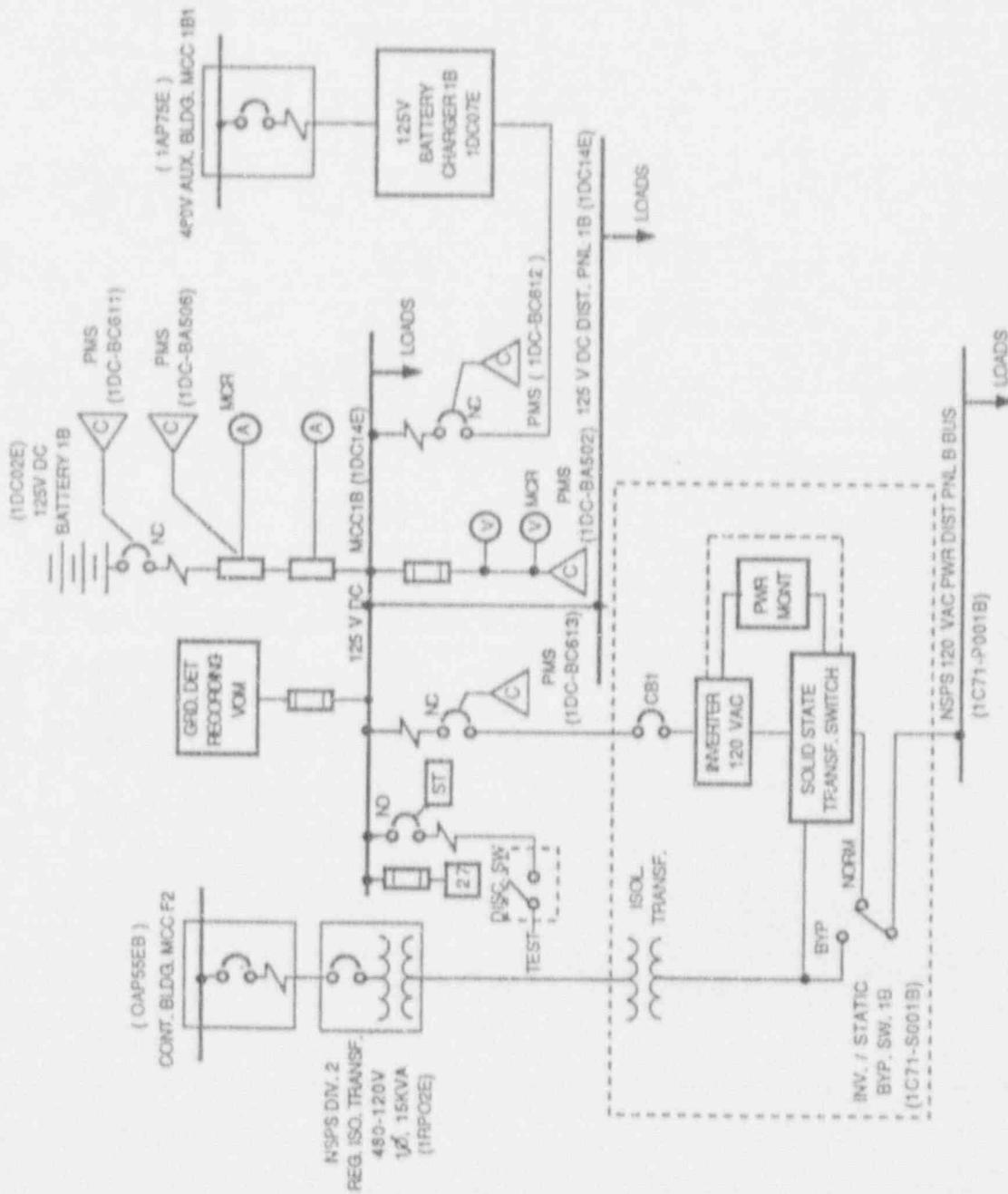

Figure 3.2-38
Division 2 DC Distribution System

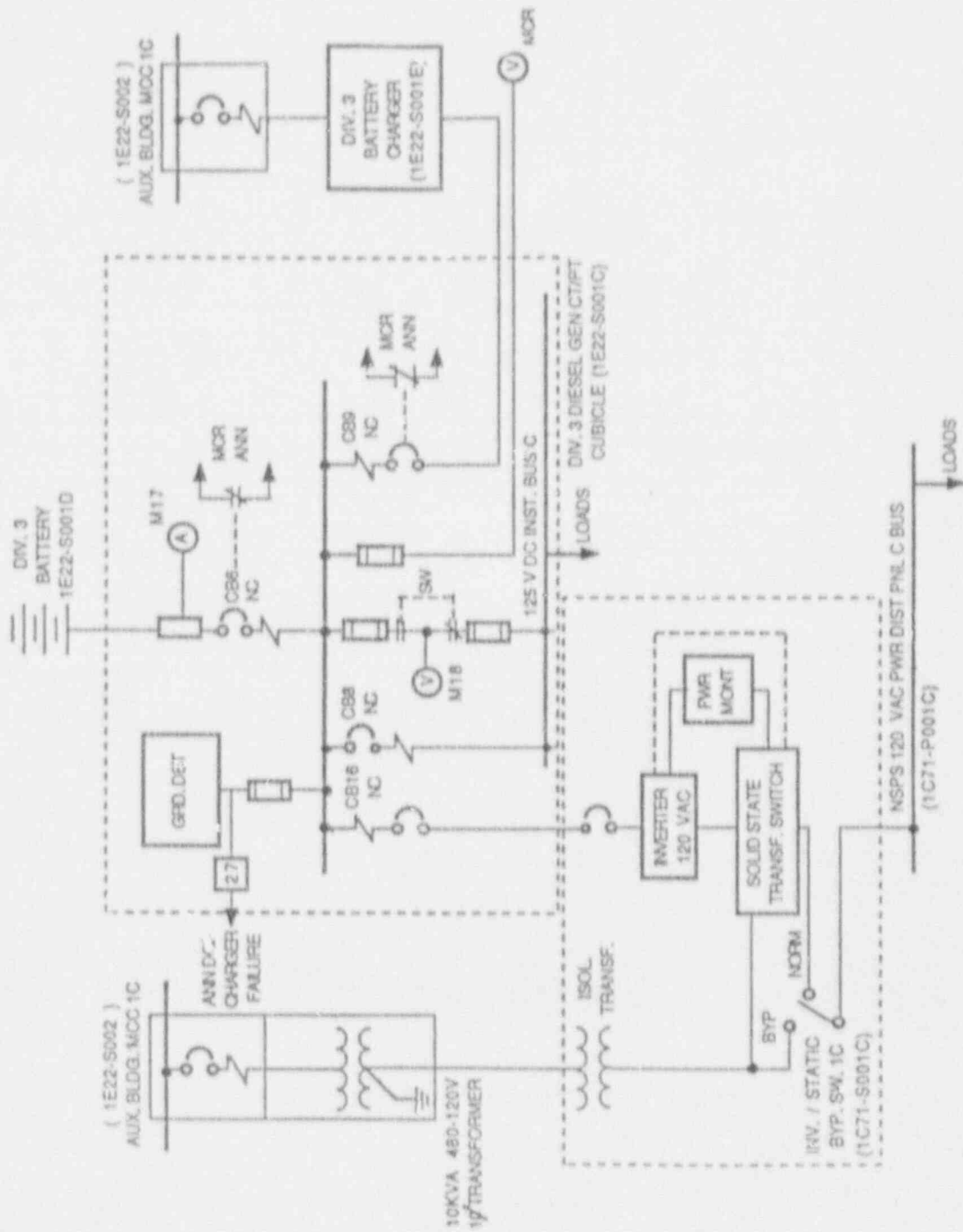

Figure 3.2-39
Division 3 DC Distribution System

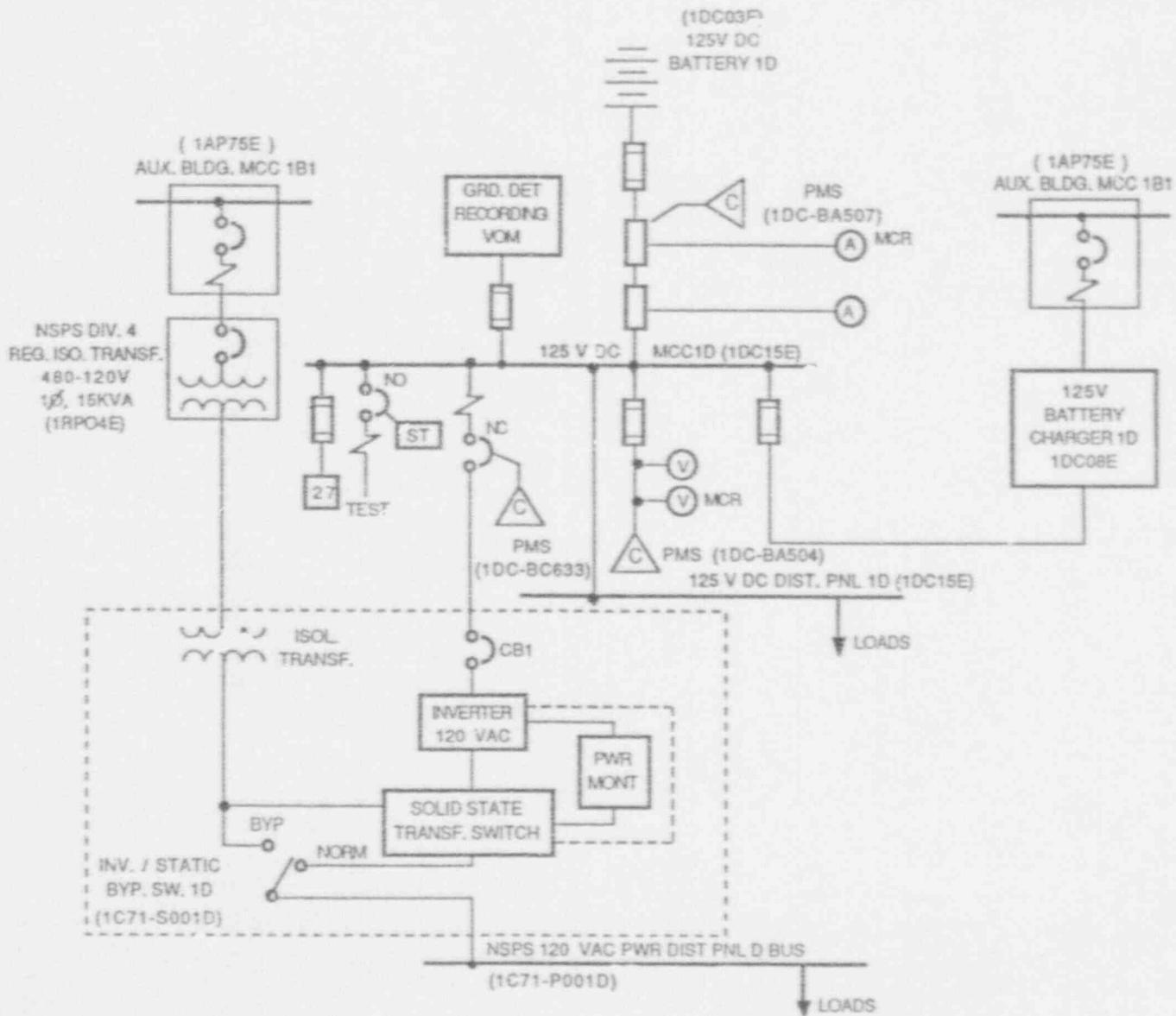

Figure 3.2-40
Division 4 DC Distribution System

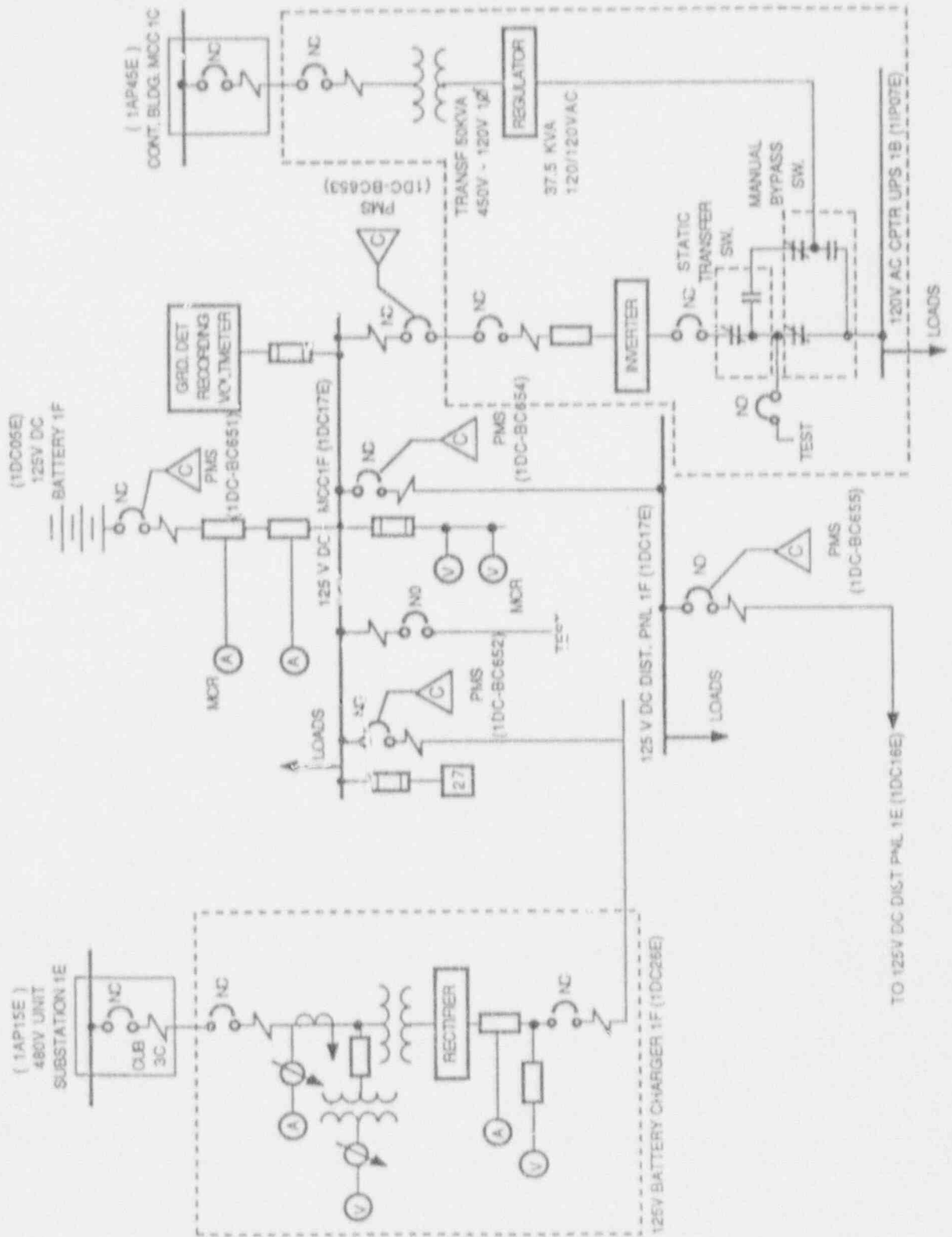

Figure 3.2-41
Balance of Plant DC Distribution System
Sheet 1

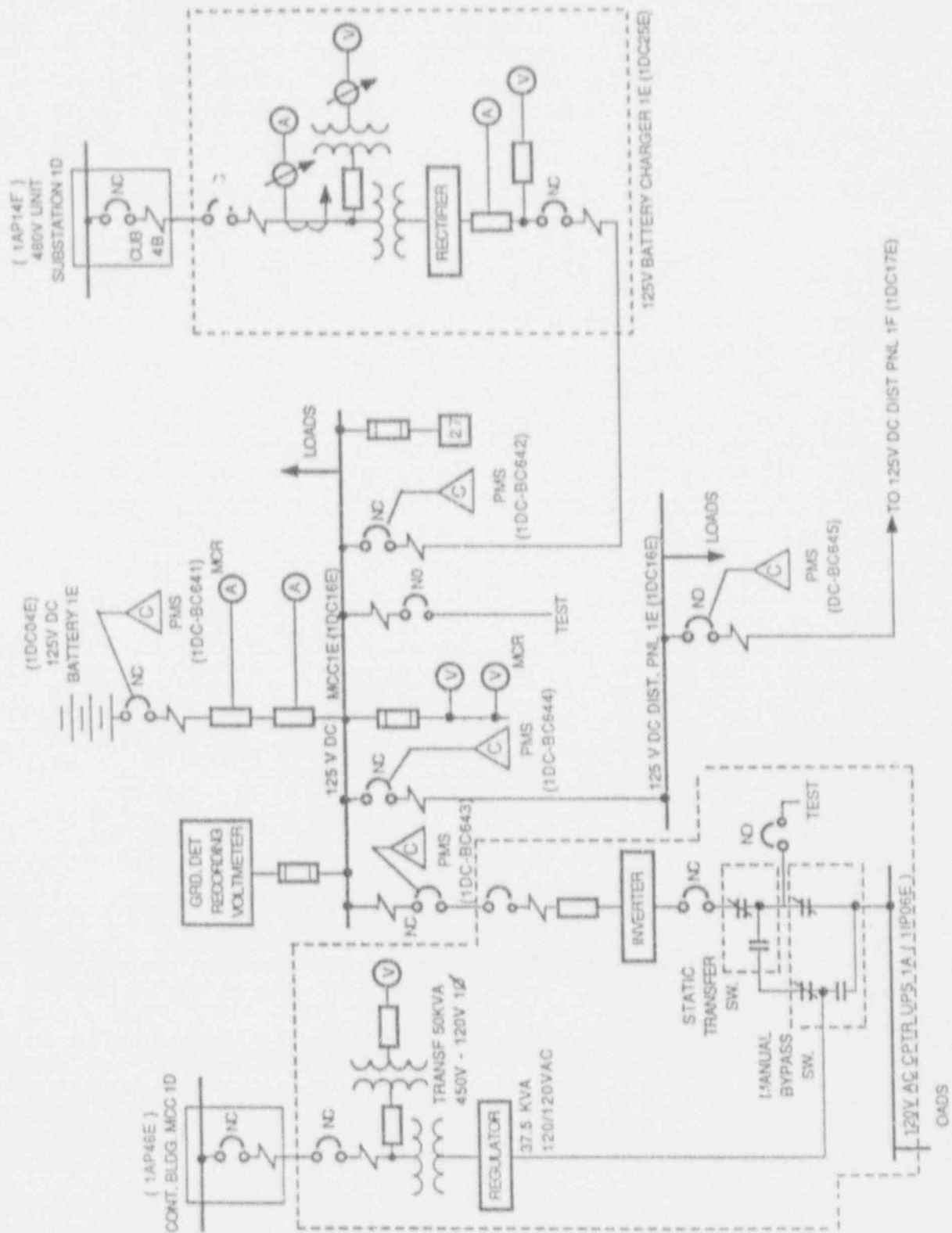
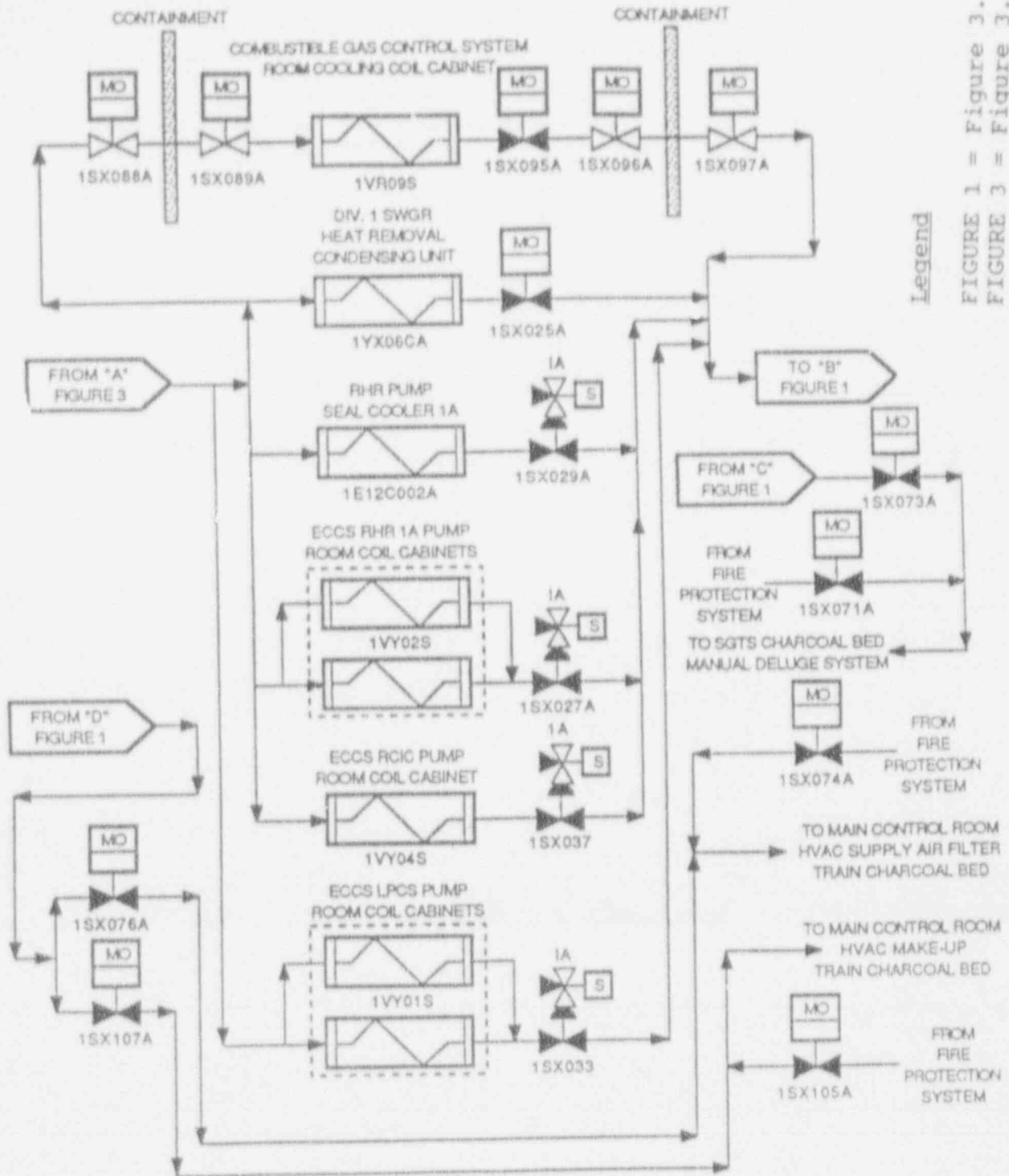

Figure 3.2-42
Balance of Plant DC Distribution System
Sheet 2



Legend

FIGURE 1 = Figure 3.2-43
 FIGURE 3 = Figure 3.2-45

Figure 3.2-44
 Division 1 Shutdown Service Water System
 Sheet 2

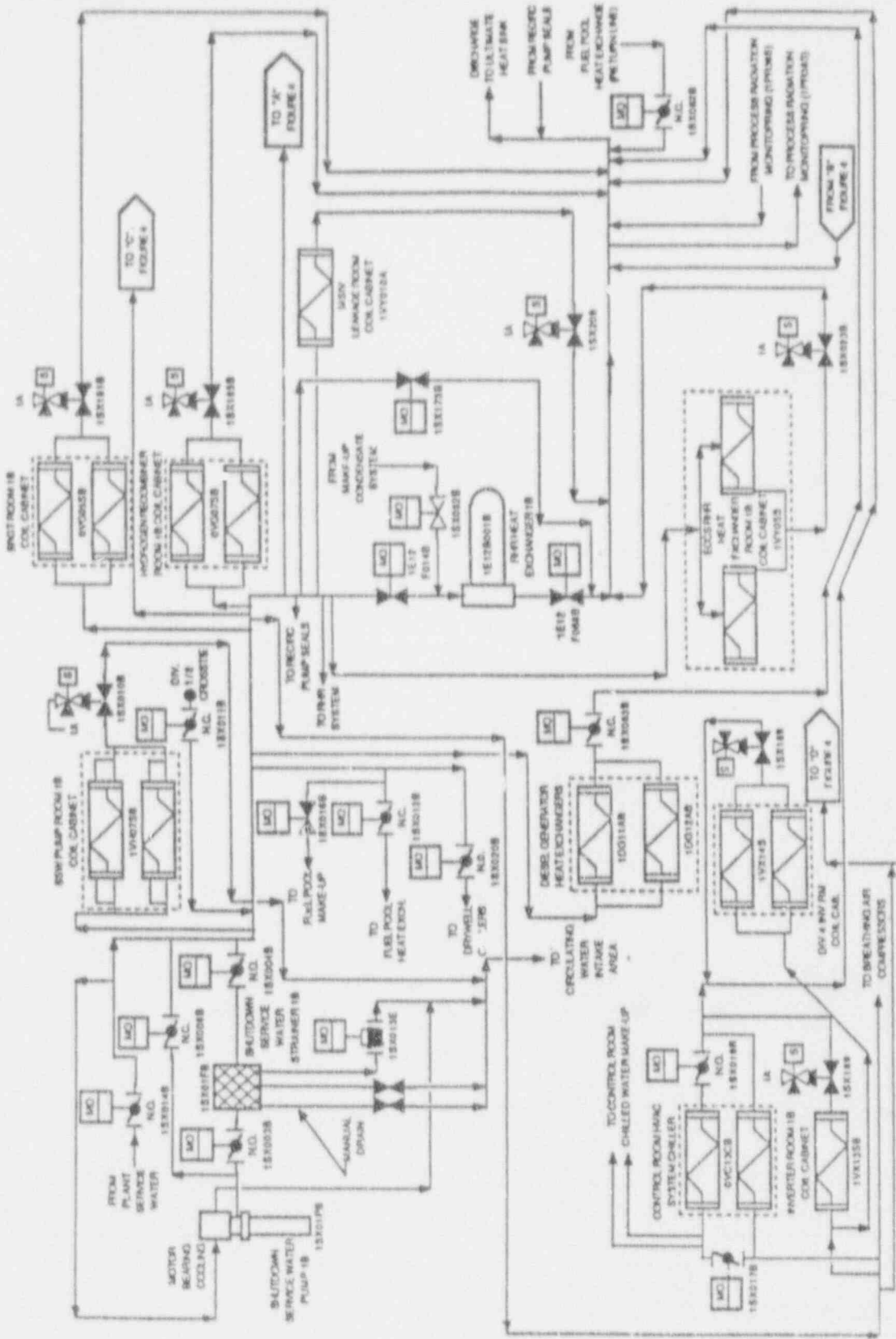

Figure 3.2-45
 Division 2 Shutdown Service Water System
 Sheet 1

Legend

FIGURE 4 = Figure 3.2-46

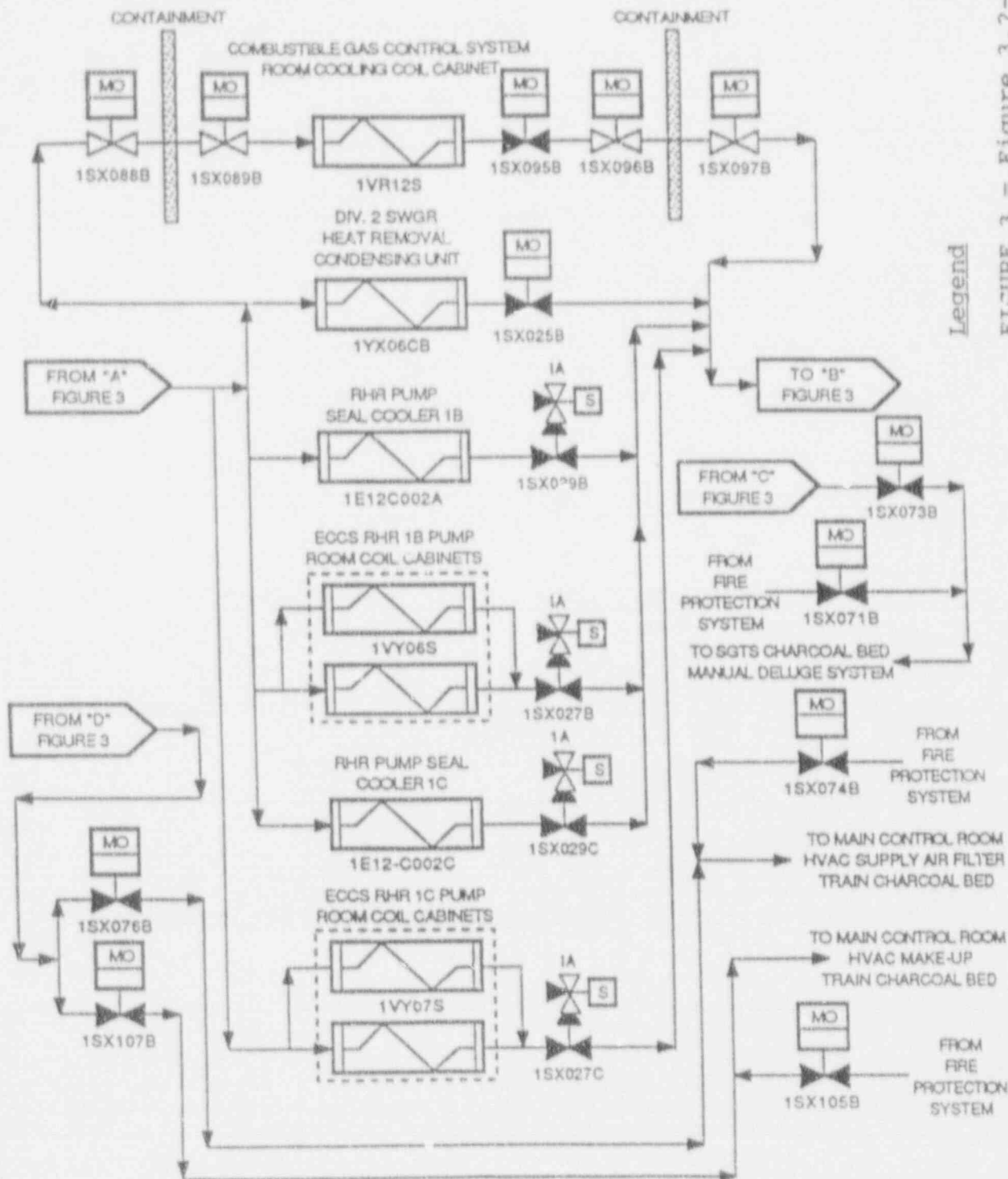

FIGURE 3 = Figure 3.2-45

Figure 3.2-46
 Division 2 Shutdown Service Water System
 Sheet 2

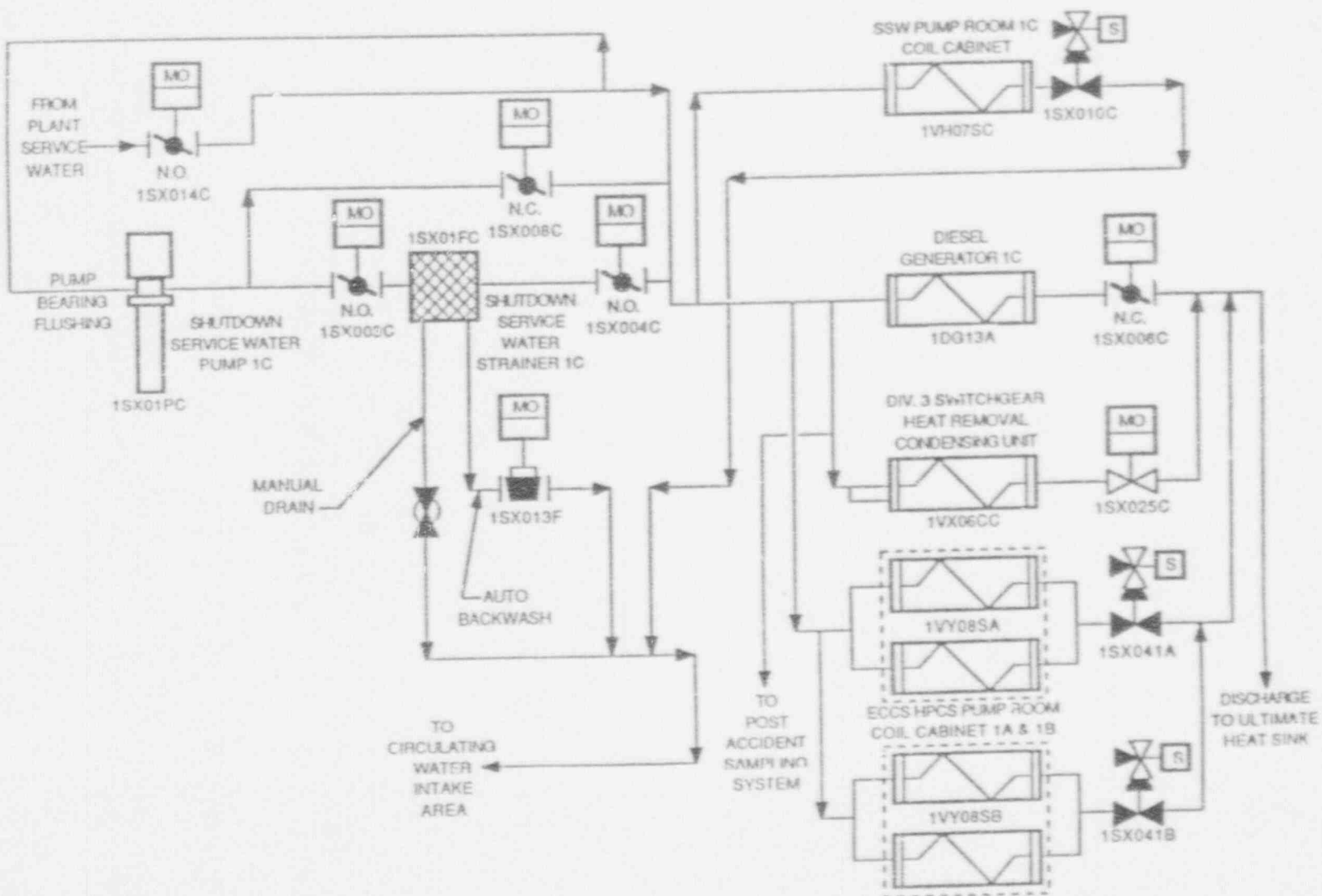
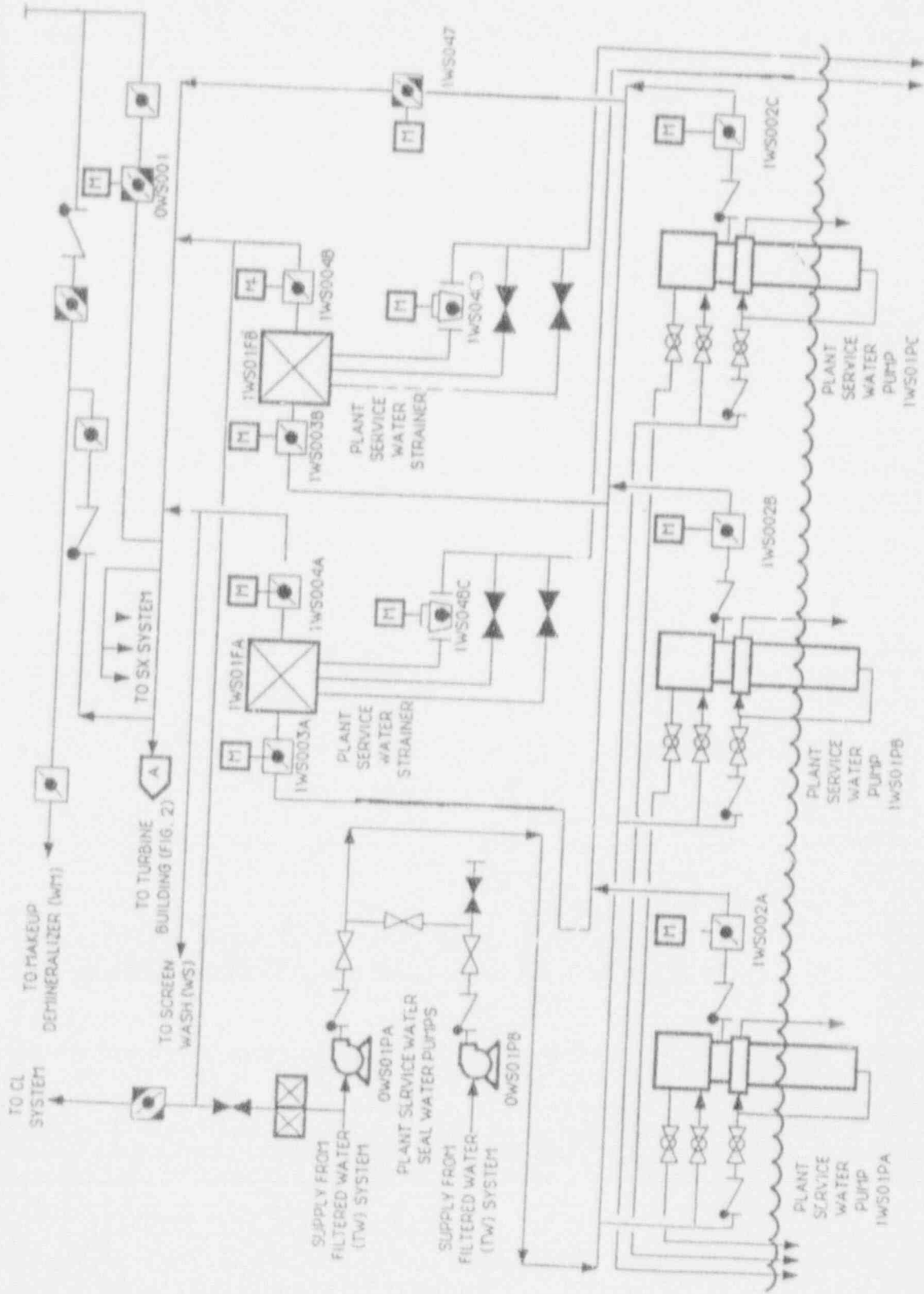

Figure 3.2-47
Division 3 Shutdown Service Water System



Legend

Figure 3.2-48
Plant Service Water System
Sheet 1

FIGURE 2 = Figure 3.2-49

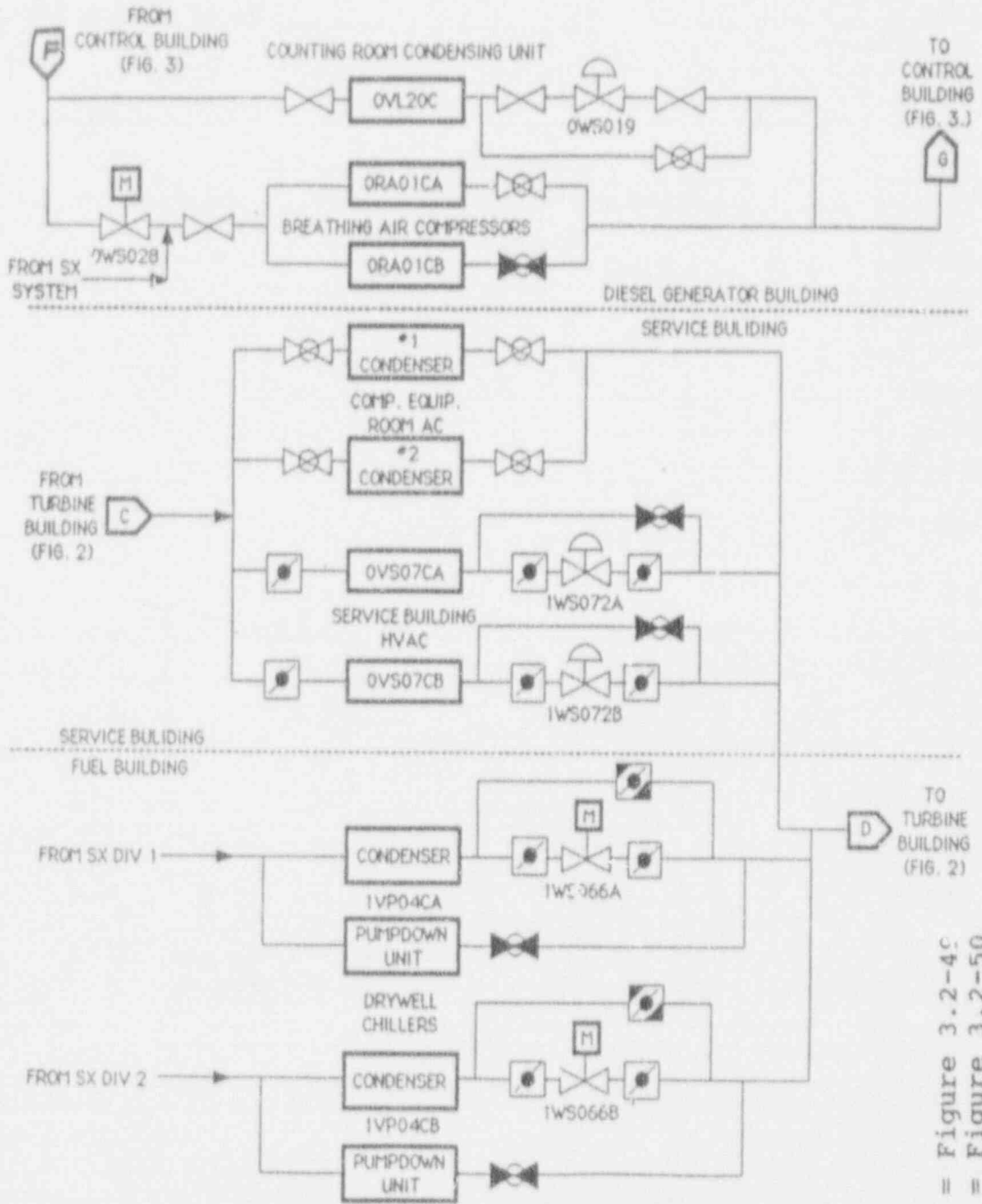

Legend

FIGURE 2 = Figure 3.2-4c
FIGURE 3 = Figure 3.2-50

Figure 3.2-51
Plant Service Water System
Sheet 4

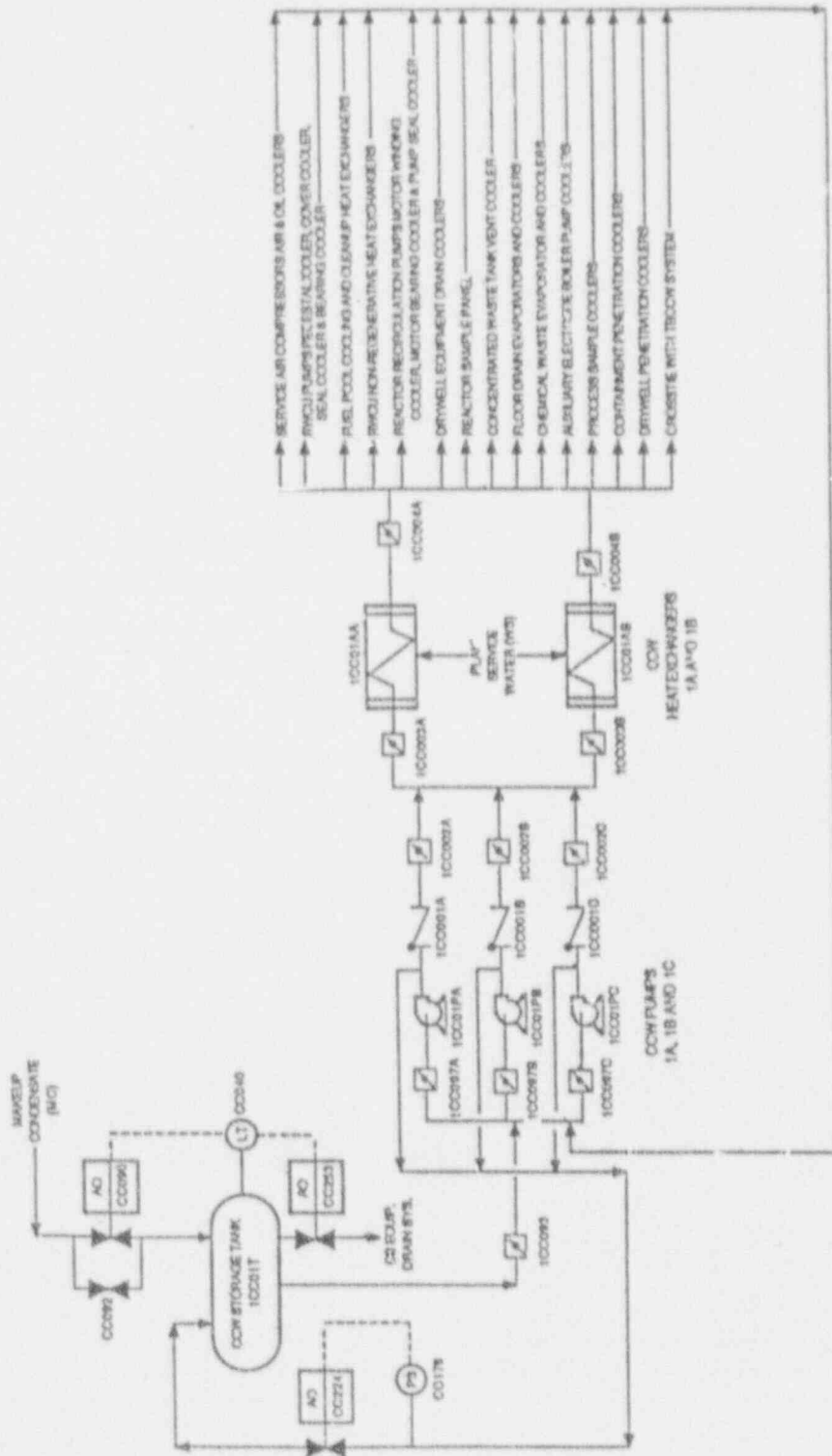

Figure 3.2-53
Component Cooling Water System

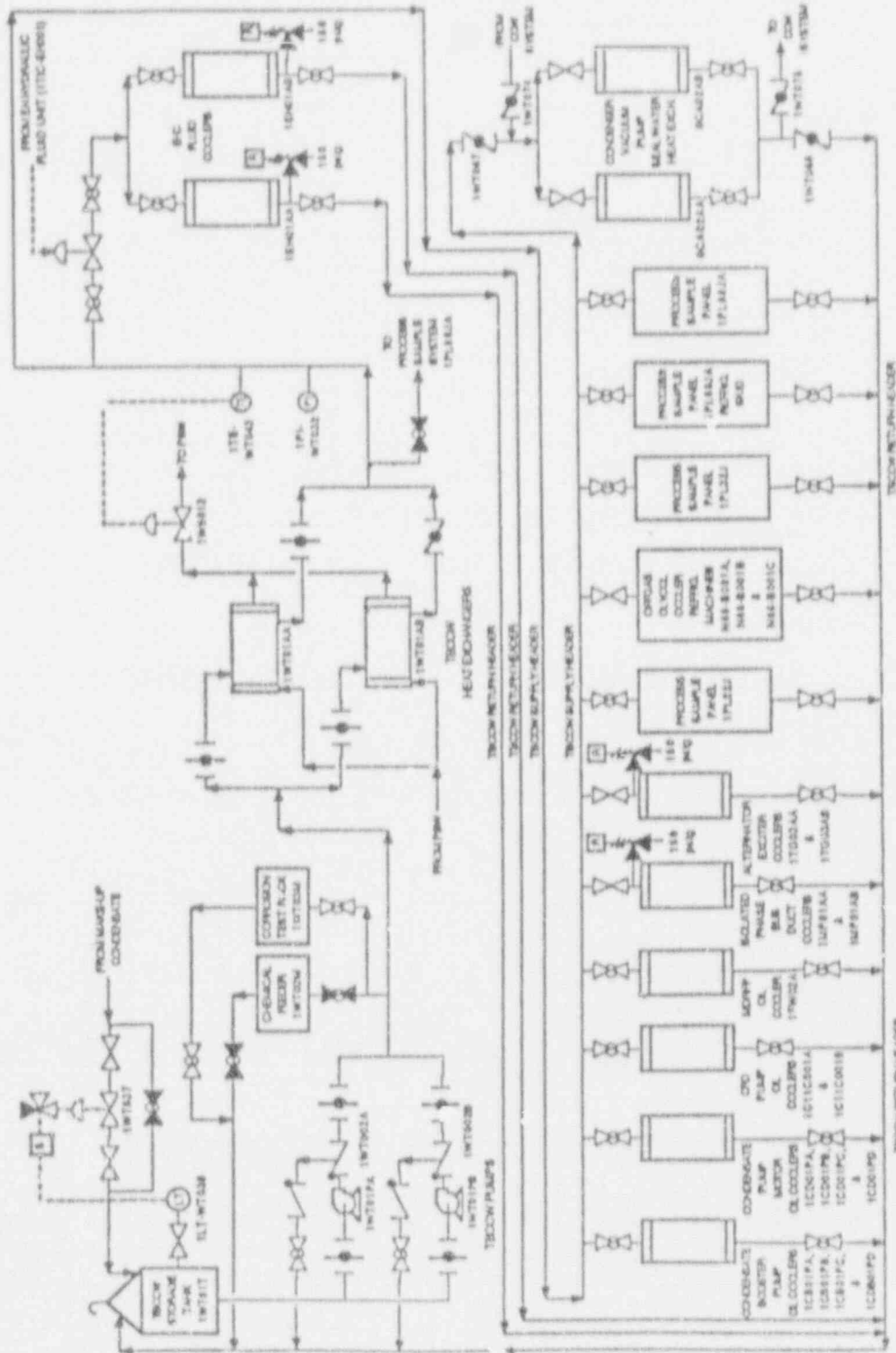

Figure 3.2-54
Turbine Building Closed Cooling Water System

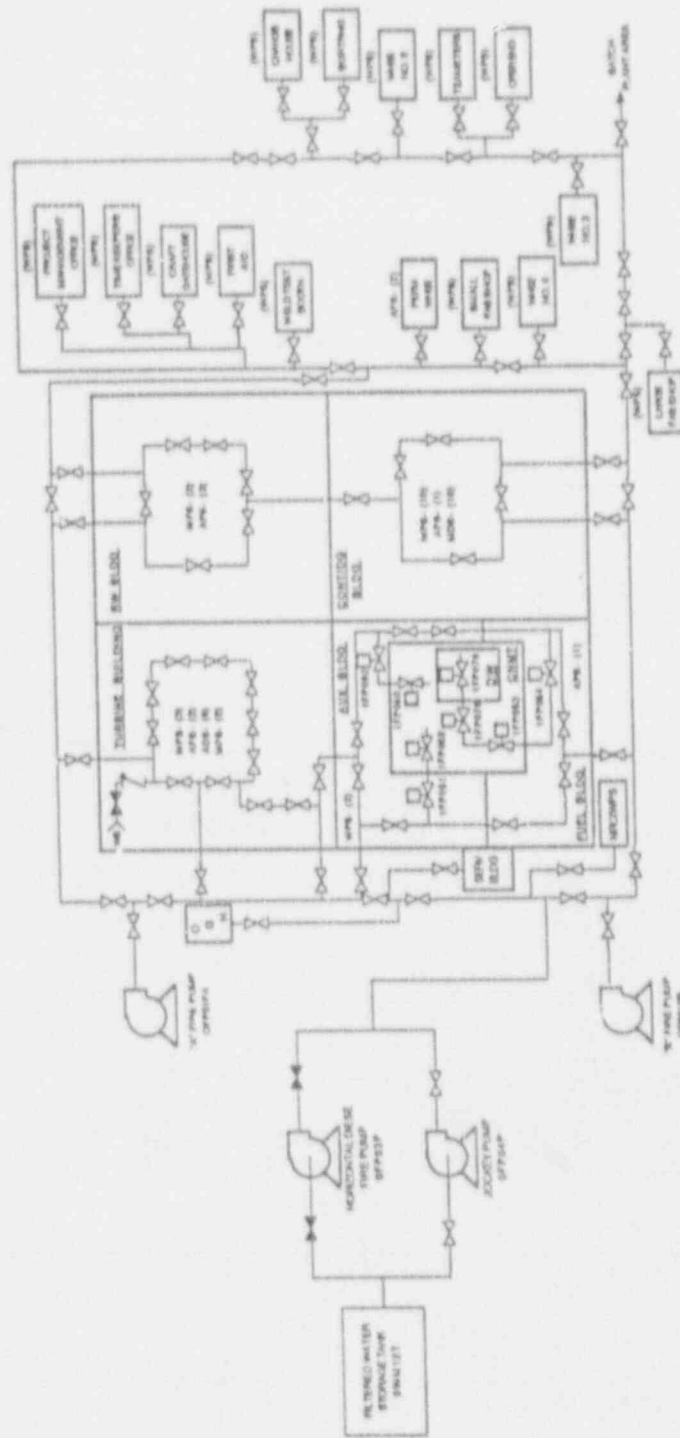

Figure 3.2-55
Fire Protection System

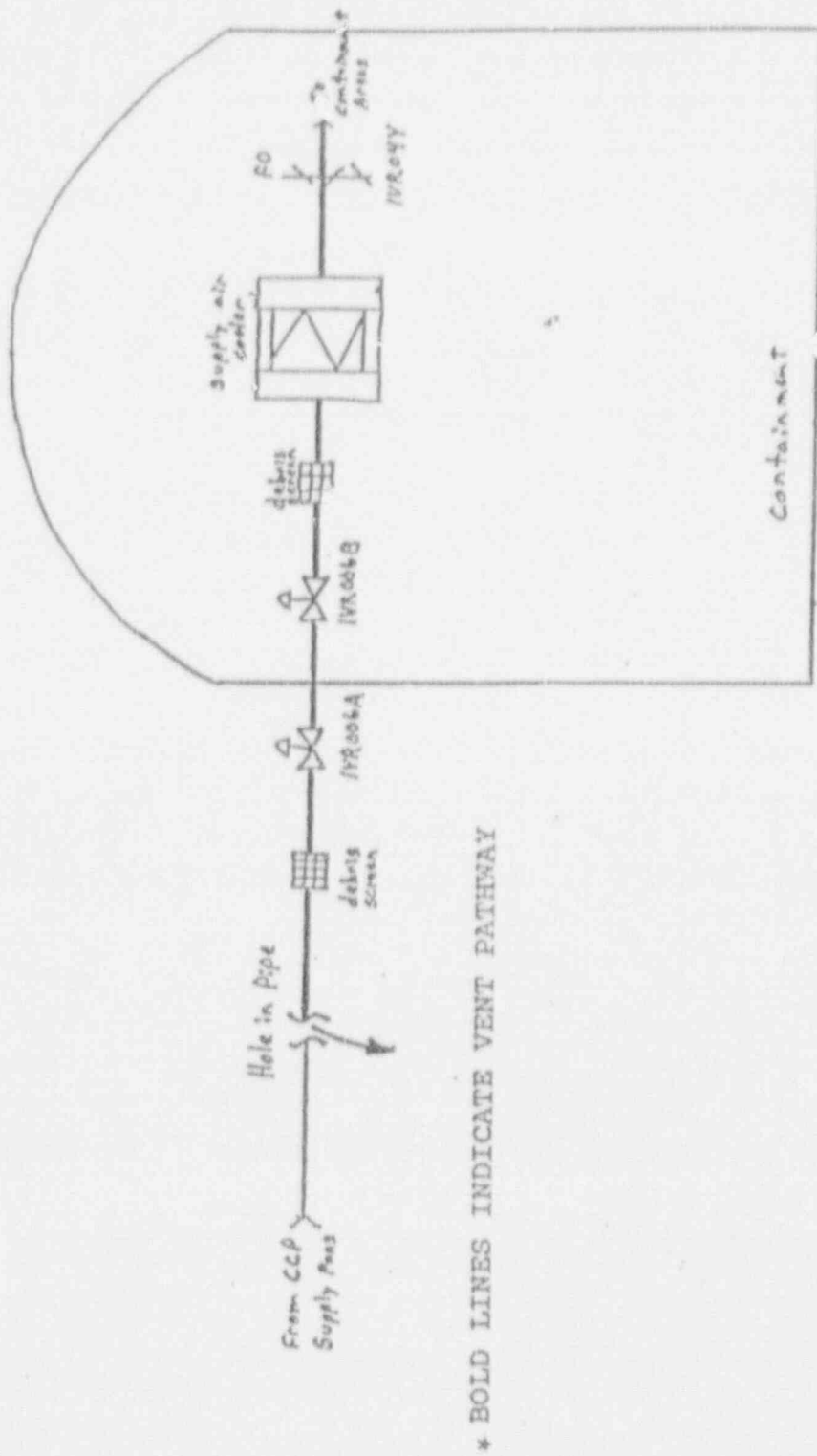

Figure 3.2-56
Containment CCP Vent Pathway

3.3 Sequence Quantification

This section discusses the derivation of component failure probabilities assigned to basic events in the Clinton Power Station (CPS) Probabilistic Risk Assessment (PRA) and the quantification of the system models and event tree sequences using this data. The basic event probabilities represent the likelihood that components modeled in the fault trees are unavailable due to hardware failure or out of service due to maintenance or testing. Failure events are defined by a specific component and failure mode (e.g., pump fails to start, valve fails to remain open, etc.).

Failure probabilities can be determined from plant specific or generic data. The use of plant specific data is preferred because this would allow a greater potential to gain insights into CPS's response to transients. However, due to the limited operating experience at CPS (<6 years), inherent uncertainties in plant specific data leave generic data as the best choice.

Plant specific or generic component failure rates fall into one of two categories.

1. Demand failures - a component fails to perform its intended function on demand (e.g., pump fails to start, valve fails to open).
2. Time dependent failures - failures occur at a constant rate in time, the probability of failure is independent of the time of previous failures, if any.

The demand failure probability model assumes a constant probability of failure at each demand on a component regardless of the time between demands. However, the generic demand failure probability estimates include failures that occur between demands, but are only discovered when a component is called on to perform its intended function. This type of failure is more

likely to occur if the time between demands is long. Therefore, the actual unavailability of components due to demand failure is not completely independent of the time between demands. Conversely, if components are operated on demand several times in a short period, then the probability of failure is not completely proportional to the number of demands. The failure mechanism occurring between demands is not as likely on a per demand basis when the interval between demands is short. This affects the assignment of demand failure probabilities to components that undergo multiple demands such as safety relief valves (SRVs). These refinements to the generic demand failure were not exploited, however.

The constant time failure rate model assumes failures occur at a constant rate in time; the probability of failure in an interval is independent of the time of a potential previous failure. The time between failures follows an exponential distribution. The model parameter estimated is the hourly rate of component failure.

One version of this model assumes that the status of the component is checked periodically. Periodic tests verify the operability of the components, but the component remains failed between the time it initially fails and discovery of the failure during testing. If it is assumed that failures occur with uniform likelihood between tests, then the average time the standby component is unavailable is approximated as the product of the failure rate and one half the time between tests ($\lambda \times \text{test interval}/2$). This version of the time failure rate model was applied to standby and passive failure modes such as failure of manual, motor operated, and air-operated valves to remain open. Valve position is verified by periodic system flow tests.

In another version of the constant time failure rate model used for components that must operate for a substantial period of time after starting or must remain in a changed state, unavailability is approximated as the product of failure rate and mission time.

Mission time is defined as the time that a component is required to operate successfully. This version of the model is used for the failure to run of pumps or diesel generators, failure of valves to remain open or closed, and filters or heat exchangers becoming plugged. For the CPS IPE, the mission time is 24 hours.

3.3.1 List of Generic Data

Generic estimates were used in most cases to derive the failure probabilities for the Clinton Power Station (CPS) Probabilistic Risk Assessment (PRA) basic events. These estimates were obtained from industry recognized sources. The decision to use generic rather than plant specific data was based on two major factors:

1. CPS had been operating for approximately six calendar years when the basic event probabilities were derived. This short period of time is unlikely to provide sufficient data for most plant specific estimates in the PRA. It is expected that these failure rates over time will not be statistically different from generic data.
2. Component failure data from the first years of plant operation is typically excluded from failure rate estimates because components typically experience a higher than normal number of failures during this break-in period. This data is usually not representative of component long term reliability and is not used to predict future reliability.

The sources of generic failure rate data used for the CPS IPE are as follows:

1. NUREG R-4550, Volume 1, Revision 1, "Analysis of Core Damage Frequency Grand Gulf Unit 1 - Internal Events",

2. NUREG/CR-2815, "Probabilistic Safety Analysis Procedures Guide"
3. Institute of Electrical and Electronics Engineers (IEEE) Standard 500, "IEEE Guide to the Collection and Presentation of Electrical, Electronic, and Sensing Components Reliability Data for Nuclear Power Generating Stations".
4. General Electric reliability data reports.

Table 3.3-1 provides the events which used generic data and the source of the data.

3.3.2 Plant-Specific Data and Analysis

Components and systems can be out of service either because of failure or for maintenance and testing. The following is a brief discussion on the derivation of data for these two categories.

3.3.2.1 Failure Rates

Plant-specific failure rate estimates were derived for the failure of the diesel generators to start. The diesel generators have been started a sufficient number of times (306) during the plant operating history (9/1/86 - 3/7/92) for surveillance testing to determine a plant-specific failure rate estimate. Generic data was used for other components.

The number of valid start failures and demands for each diesel was determined from plant logs. Post maintenance testing and trouble shooting starts were not counted as valid demands. If a diesel successfully started but did not start within a prescribed time, this failure was not counted as a valid failure for the purpose of this study.

The number of valid start failures and demands for each diesel was reviewed to determine if there was a marked difference in reliability for each diesel. No such differences were found. The data for all three diesels were combined to determine a single failure rate estimate for all three diesels. This resulted in a demand failure probability estimate of $2.0E-02$ which compares closely with the generic estimate of $3E-02$ in NUREG/CR-4550.

3.3.2.2 Maintenance and Testing

There are two general categories of maintenance actions:

1. Routinely scheduled maintenance - Maintenance occurring periodically which is intended to ensure that a component operates at peak efficiency (preventative maintenance). Examples include oil changes, bearing replacement, filter replacement, etc.
2. Unscheduled maintenance - Maintenance involving repair or replacement of a component due to failure during normal operation or upon detection during periodic testing (corrective maintenance).

Unscheduled maintenance activities usually require a longer period of time to complete than scheduled activities. The frequency of both scheduled and unscheduled maintenance can vary significantly from system to system depending on operating philosophy, e.g., waiting until scheduled outages rather than taking components out of service during normal plant operations.

Plant specific data was used to derive the fraction of time a given component or train of equipment could be expected to be out of service for maintenance. Plant data was assembled for the time period 10/15/87 through 1/4/92, exclusive of planned and forced outages.

Testing actions refer to periodic operations or inspections of components that verify they can perform their intended function. These acts are usually performed to satisfy requirements contained in the CPS technical specifications. In many cases the systems are designed to automatically realign if an accident sequence were to occur during a routine test and, if so, testing time was not counted as unavailable time. Information used to derive component unavailability during testing was obtained from a review of CPS surveillance procedures.

3.3.3 Human Failure Data (Generic and Plant-Specific)

Human error has been included in the Clinton Power Station (CPS) probabilistic risk assessment (PRA) in several ways. First, routine actions such as testing and maintenance result in the unavailability of systems and equipment. Second, errors made by personnel, either before, during, or after an event, could affect the outcome. Recovery actions possibly taken to restore failed equipment or to correct errors are also included.

The human reliability analysis (HRA) for the CPS PRA entails the estimation of human error probabilities (HEPs) for various operator and other plant staff actions which affect the model. These personnel actions are called human interactions (HI). The HI basic events were identified and defined in the development of both the system models (fault trees) and the failure sequences (event trees).

3.3.3.1 Types of Human Errors Modeled

Numerous human interactions are relevant to the successful operation of plant systems modeled in the CPS PRA. Those interactions which have a crucial effect on systems, trains, or components are represented by human error events in the fault trees. Additionally, some operator actions are modeled

individually as event tree headings, particularly in the station blackout (SBO) and anticipated transient without SCRAM (ATWS) event trees.

Three categories of human interactions were considered for the CPS PRA model. These are

- Pre-initiating event interaction,
- Human actions which lead to an event, and
- Post-initiating event interactions.

The first category includes failures to restore equipment properly following testing or maintenance and failure to calibrate instruments correctly. Human errors that lead to initiating events are captured in the initiating event frequency estimates derived for accident sequence quantification. Since initiating event frequencies are determined empirically, these events will not be discussed further. Finally, the post-initiating event human interactions include operators failing to take the necessary action to ensure successful system operation. This includes failures to initiate system operation manually, failure to take actions to ensure continued system operability during the system mission time, and restoration of failed systems.

3.3.3.1.1 Pre-Initiation

A number of systems and components are susceptible to the failure to properly restore following testing and maintenance, or improper instrument calibrations. Provisions may exist for automatic override of the system to the required configuration when an initiating event occurs. If this occurs, the restoration error event is eliminated from the fault tree. If the system is normally manually started and the steps required to start the system include the necessary lineups, then the improper restoration error was not included. Otherwise if the system is not automatically aligned to its proper configuration, the probability that the system will not be manually restored

following test or maintenance was determined. Table 3.3-2 contains the restoration and calibration error probabilities. There is a total of approximately 131 pre-initiation events in the models.

3.3.3.1.2 Post-Initiation

Post-initiator events include two categories, procedural actions and restoration of failed components or systems.

The first type of action relates to proceduralized actions that are taken by the operator in response to an event. These are primarily in the emergency operating procedures (EOPs), but include steps in support procedures. They include manual alignment of systems into configurations different from their normal (design) alignment; For, example, the alignment of the Fire Protection (FP) system as a source of injection to the reactor vessel or manual starting of the Standby Liquid Control (SLC) system. There are about 33 procedural events modeled. Table 3.3-3 contains these post-initiator human interaction probabilities.

The second type of action involves the repair or restoration of systems assumed in the event trees or fault trees to have failed. For example, recovery factors can be applied to the restoration or repair of the Residual Heat Removal (RHR) or the diesel generators after failure has been previously assumed. There are about 44 repair or recovery actions. These are further discussed in section 3.3.3.2.

3.3.3.1.3 Human Error Probability

The determination of human error probabilities (HEP) followed two general methods. The first method is for pre-initiator actions and post-initiator actions that are proceduralized. This method is described in the following sections. A different method was used for recovery of failed components and systems. This method is described in section 3.3.3.2.1. The determination of the appropriate human error probability (HEP) for each identified operator action was accomplished in five major steps. First, a conservative screening value was derived for each human interaction using the methodology discussed below. After quantification, a sensitivity analysis was performed to identify the more important actions. These were then analyzed using a more detailed human error evaluation method. Fourthly, a dependency analysis was performed to account for the interaction when the operating crew must accomplish two or more actions in one sequence. Finally, near the end of the project after the models had been refined over several months, sensitivity analysis were reperformed. These steps and the results are discussed below:

3.3.3.1.4 Screening HRA

The screening methodology develops HEPs that are conservative in comparison to estimates that might be realized by following more detailed methods. The method relies principally on the NUREG/CR-1278, "Handbook of Human Reliability Analysis with Emphasis on Nuclear Power Plants", developed by Swain and Guttman. This document explains the basic terms, discusses performance-shaping factors, and human performance models. The various models allow the development of HEPs under a variety of conditions that may be encountered in nuclear plants.

Later methods have attempted to refine the ideas presented in NUREG/CR-1278 by developing more detailed human performance models and including supporting data (for example, by observing training exercises and evaluating the responses). These generally have tended to produce lower failure estimates than direct application of NUREG/CR-1278.

Three categories of human actions were considered for assigning screening analysis HEPs. These categories are as follows:

- 1) Failure to align systems and/or components properly following test or maintenance;
- 2) Manual alignment of systems into configurations different from their normal alignment; and
- 3) Actions that are taken by the operator in response to a transient that are specified by the Emergency Operating Procedures and the satellite procedures.

To treat these categories of human actions consistently, an HRA guideline was prepared for the CPS IPE derived mainly from NUREG/CR-1278. This was necessary because NUREG/CR-1278 contains such a large amount of information on human failures that there may be several interpretations of the data or methods used to apply the data.

The guidelines for the screening HRA consist of flow charts and tables designed to determine which of the human actions are involved, then assess the conditions, performance shaping factors, or the particular situation. For example, the flow charts ask whether the action is a simple manual task specified by EOPs, whether the available time to accomplish the action to prevent core damage is short, whether sufficient information is available to correctly diagnose the situation, and whether the stress of the initiator is high. Based on the responses to these questions, the analyst

is either routed to tables of time dependent values of HEPs or led to an assigned HEP value. These values are taken from the information presented in the NUREG.

The model utilized in the HRA guideline for the time dependent HEPs for routine operator actions performing simple tasks was taken from the industry degraded core rulemaking committee (IDCOR) individual plant examination methodology (IPEM) for boiling water reactors (BWRs). The methodology taken from this report was actually derived from and applied consistently with NUREG/CR-1278. The data taken from NUREG/CR-1278 was extrapolated in the IDCOR Technical Report 86.3B1, Individual Plant Evaluation Methodology for Boiling Water Reactors, Volumes I & II, cover the very early period of time after an event occurred while remaining consistent with basic HEPs in WASH-1400 and NUREG/CR-1278 (i.e., operator actions required within the first minute were assigned a HEP of 1.0). Thus the CPS screening process is essentially based on the models and conditions specified in NUREG/CR-1278.

3.3.3.1.5 HRA Sensitivity

After core damage sequences were quantified using screening HEPs, the core damage sequence frequency results were reviewed to determine the significant human actions which should be subjected to detailed analysis and derivation of more representative HEP. The purpose in performing more detailed HRA evaluation on those human actions determined to be significant was to assure that the plant procedures, training and equipment were appropriately represented by the HRA model. In addition, constructing a detailed HRA analysis that fairly represents the plant allows more appropriate insights to be drawn. Two primary criteria were used to select human actions for more detailed analysis.

First, actions were selected that appeared to have a significant affect on the core damage frequency. Detailed analysis of every action could lead to a refinement in core damage frequency and a more thorough understanding of the plant's ability to withstand accidents through its operation, training and equipment. However, many possible human errors have an inconsequential effect on plant risk. With limited time and resources, only those errors that could have a significant impact on core damage frequency were considered for detailed analysis.

Human interactions which had a Fussell-Vesely importance measure of greater than or equal to 0.1 were selected for sensitivity analysis. If the sensitivity study resulted in a change in core damage frequency greater than $5E-06$, the human interaction was selected for the more detailed analysis.

Second, the core damage sequence results were examined to see if potentially non-conservative HEP estimates for any operator actions could have led to non-conservative sequence quantification results.

Table 3.3-4 contains the sensitivity analysis of important human interactions.

3.3.3.1.6 Detailed HRA

For the detailed analysis, the derivation of HEPs was performed according to the Accident Sequence Evaluation Program (ASEP) human reliability analysis method as described in NUREG/CR-4772, "Accident Sequence Evaluation Program Human Reliability Analysis Procedure". This method bases human error probability estimates on the time available to complete the action, the procedural guidelines available for the action, the training of operators on the action, the stress associated with the action, and the potential for different operating crew members to correct mistakes. These characteristics were assessed for each action

analyzed under this method, and probability estimates were derived.

The techniques that have been developed for human reliability analysis involve the following steps: 1) breaking down the human action into smaller constituent actions, 2) evaluating the likelihood of errors in these individual actions, and 3) deriving the total human error probability by combining the probabilities of the individual action errors. The error probabilities are derived by considering performance shaping factors (PSFs) that influence the likelihood of errors. PSFs considered include procedures, training, the complexity of the required action, the time available to perform the action, and the likely stress of the situation.

The first step of the ASEP methodology is to specify the initial conditions and assumptions that apply to each individual human action. Next, applicable emergency, off-normal, operating and annunciator procedures were reviewed. Aspects of procedures that affect task performance include the following:

- Existence of symptom-oriented EOPs
- The degree to which non-EOP procedures are required
- The clarity of the referenced procedures
- How well the procedures "tie" together
- How the individual procedures are organized internally

Review of procedures allows an assessment of the quality of the guidance given to the operators when a particular action is required. If procedures offer clear and unambiguous guidance, a lower probability is assigned; if procedures do not clearly point toward appropriate action, then a higher failure probability is assigned.

The plant procedures also provided the basis for determining what subtasks composed the modeled actions. Many of the modeled human actions required an operator to perform multiple tasks or require two operators to perform tasks in parallel.

Another area that affects the assignment of human error probabilities in the ASEP method is operating crew training. In general, actions that are emphasized in training receive lower HEP assignments, while actions that are not covered receive higher HEP assignments.

Following the procedure and training review, an in-depth system analysis of annunciators and instrumentation was performed to identify which indications provide signals that allow and/or assist in the diagnosis of an event. From the set of all indications that occur as a result of a modeled event, a single signal which is viewed as the earliest or most informative signal was chosen as the "compelling" signal.

The ASEP procedure utilizes several time intervals in the calculation of the diagnosis HEP. These intervals are as follows:

T_a - Time needed to reach a particular location and perform a required action once a correct diagnosis of an initiating event has been made.

T_m - Maximum time available for diagnosis and performance of an action following the initiating event that will prevent core damage.

T_d - Maximum time available for diagnosis which will still allow performance of the specific human action. T_d equals $T_m - T_a$.

T_a was measured through actual walkdowns of equipment for locations outside the main control room, and by operator and training instructor's estimates for actions performed inside the main control room. T_m was determined using the Modular Accident Analysis Program (MAAP) and a variety of system/equipment specific engineering calculations. Computation of an overall HEP using the ASEP methodology involves the calculation of HEPs specifically related to diagnosis, performance, and performance recovery.

A careful selection process for appropriate HEPs was carried out using ASEP. Each human action selected for the detailed HRA was evaluated against six performance shaping factors. In addition, an interview was held in the CPS simulator with an operating crew (control room and unit attendants) and two training instructors. The human actions under analysis and their associated PSFs were reviewed by the crew and instructors. Utilizing comments from the crew and instructors with the documents referenced above, the ASEP methodology was applied for the six selected actions. Table 3.3-5 contains the results of this analysis.

As part of the Detailed HRA, an expert consultant, D.G. Hoecker, of Westinghouse Electric Corporation, was retained to perform an additional review of the detailed HRA process and results. His conclusion was that the detailed HRA was properly performed and his results corroborated the results obtained by the CPS ASEP application.

3.3.3.1.7 Assessment of Dependency Among Human Error Events

Since the operating crew must detect, diagnose, decide, and act upon all actions which take place early in the scenario, it is reasonable to assume that interaction among HIs is possible. It is possible that groups of human actions in the IPE models are dependent, so that the conditional probability of one human error given that others have occurred would be higher than the unconditional probability of a single human error. If

combinations of dependent human error events occur in core damage sequence cut sets, then assigning to each event its unconditional HEP would underestimate the probability of that sequence cut set.

The HRA included investigation of dependent post-initiator human errors. HEPs were adjusted for combinations of dependent events found in the core damage sequence cut sets. The first step in this investigation was to determine the combinations of human error events that occur together in sequence cut sets. These combinations were determined by setting all HEPs to 1.0 for potentially dependent human error events. The IPE models were quantified with these HEPs and sequence cut sets were derived. Because the HEPs were set to 1, no potentially dependent combinations of human error events were lost as a result of truncation.

The resulting sequence cut sets were searched for combinations of human error events, and any combinations were noted. The degree of dependence between such events was assessed and conditional HEPs for the events given occurrence of the other events in the combination were assessed. The five levels of dependency described in NUREG/CR-1278 were employed. The following factors were considered:

- * Coincidence or close proximity in time
- * Same procedure or EOP path
- * Common diagnosis of need for operator action

The formulae from the Technique for Human Error Rate Prediction (THERP) (NUREG-2254, "Handbook of Human Reliability Analysis with Emphasis on Nuclear Power Plants") dependency model were used to determine the conditional HEP for dependent actions.

For those cutsets which had two or more dependent human actions, the dependent failure probability was inserted into the cutsets in place of the 1.0 value that had been applied to investigate these actions. The remaining HIs were reset to their prior value (screening or detailed HRA as appropriate). After these replacements, the cutsets were re-evaluated.

3.3.3.1.6 Final HRA Analysis

Since the HRA sensitivity analysis described earlier (3.3.3.1.5) was completed relatively early in the project (before several model refinements and recoveries were completed), the HRA sensitivity analysis was reperformed. All HEPs were reset to the original screening values and the model was requantified. The importance measures of basic events in the core damage results were analyzed. All post initiator HRA events with an achievement or reduction worth equal to or greater than 1.1 were retained for further review. These events have the potential for changing core damage frequency results by as much as ten percent in either direction. These events are shown in Table 3.3-6.

Basic events 6 to 12 in Table 3.3-6 were derived from empirical data as described in section 3.3.3.2.1 and were not considered further for detailed HRA. Basic events 2 through 5 in Table 3.3-6 were the result of the previous detailed HRA (3.3.3.1.6). Basic event 1 is a newly identified event resulting from this analysis. This event was scrutinized using the ASEP screening methodology. It was discovered that this event had a non-conservative value (based on the ASEP screening) which was corrected for in the final results.

3.3.3.2 Recovery Actions

Initial quantification results are generally conservative for several reasons. One is that many initial failures can be recovered by probable operator action. The initial sequence cut

sets were examined to assess the events which contribute most to core damage frequency. These events were examined to define recovery actions and assign probabilities of successful recovery.

Three types of recoveries of failed components were considered as follows:

1. Repair and restoration of failed components, such as a pump that fails to start or a valve that fails to stroke.
2. Manual initiation of systems for cases in which automatic initiation has failed and other manual system recoveries from the main control room.
3. Use of alternate systems or actions, such as using Fire Protection (FP) or Control Rod Drive (CRD) as injection sources.

These are discussed oelow.

3.3.3.2.1 Repair and Restoration of Failed Components

Basic events with Fussell-Vesely importance values greater than or equal to $1.0E-02$ were initially considered in the recovery analysis.

For components in systems that act directly as potential core cooling sources, the correct time threshold for recovery is approximately one-half hour. This is based on CPS MAAP analysis, which shows that no significant core damage results following a transient with no injection for one-half hour.

For components related to room cooling for injection systems, an appropriate time threshold is 4 hours. If such components fail, then several hours pass before injection system components in the affected rooms potentially fail because of high temperatures.

Diesel generator recovery probabilities were initially determined for one and four hours, corresponding to the time considered in the event tree for AC power recovery in time to prevent battery depletion.

The Recovery Failure Probabilities (RFPs) for significant component failure basic events were determined by utilizing the results from Electric Power Research Institute (EPRI) RP-3000-34, draft report, "Faulted Systems Recovery Experience". This method classified components into three categories by system, failure mode, and equipment type. If data for more than one category fit the component being considered for recovery, then the most appropriate value was chosen by considering the composition of the data used to derive the non-recovery probability in each category. The results are tabulated in Table 3.3-7.

Up to two recoveries per cut set have been included in this study, based on the demonstrated capability of CPS to control multiple field teams during emergency exercises, including graded exercises.

3.3.3.2.1.1 Recovery of Loss of Feedwater

EPRI RP-3000-34, "Faulted Systems Recovery Experience", had no data for recoveries of feedwater. Therefore, to quantify the recovery from loss of Feedwater (FW) initiator, the operating experience of other BWR's was evaluated to estimate the probability that FW can be recovered rapidly. Using this data, a recovery failure probability of .21 was obtained.

3.3.3.2.1.2 Recovery of AC Power Supplies

Several recovery probabilities of off-site power were developed for different time periods using NUREG-1032, "Evaluation of Station Blackout Accidents at Nuclear Power Plants". These values are contained in Table 3.3-8. A time-phased recovery was utilized for station blackout cut sets. Station blackout (SBO)

sequences involving failure to recover AC Power (off-site or division 1 or 2 diesel generators) include some failures that can occur at any point in time over the 24 hour mission time following the loss of off-site power (LOOP) initiator.

An example of the above is the failure of the diesel generators to run. Depending on when in the mission time these failures occur, more time may be available for AC power recovery; consequently the probability of failing to recover AC power may be lower. For example, if a diesel generator fails to run after running successfully for 4 hours, the amount of time available for off-site power recovery is increased by 4 hours. Because the probability of recovering off-site power increases markedly over time after the LOOP initiator, the time at which the diesel fails has a significant effect on the overall probability of any sequence cut set involving the diesel failure and LOOP. Probabilities were derived for cut sets involving diesel generator failure to run events along with failure to recover off-site or failed diesels, taking into account a time-phased recovery probability. These probabilities are for the diesel failure and the failure to recover off-site power and the failure to recover the failed diesel. Tables 3.3-9 and 3.3-10 list the time-phased recoveries for the two applicable station blackout sequences.

3.3.3.2.2 Manual Initiation Recovery Events

To determine the failure probability for the manual initiation of Emergency Core Cooling Systems (ECCS) recovery action, the methodology from IDCOR Technical Report 86,3B1, "Individual Plant Examination Methodology for Boiling Water Reactors", was used. This is the guidance used in the screening analysis discussed in Section 3.3.3.1.4. A MAAP simulation which involved a transient with no injection shows that the operator would have approximately 12 minutes before reactor water level would reach the top of active fuel. This results in a failure to recover probability of 0.009.

For manual initiation of Division I or II Shutdown Service Water (SX), the initial screening value obtained as described in Section 3.3.3.1.4 was retained.

3.3.3.2.3 Recovery Using Alternate Systems

In the event of loss of all safety-related injection systems (i.e., a common cause Shutdown Service Water (SX) failure) and loss of Condensate (CD)/Feedwater (FW) (such as by DC bus failure), Control Rod Drive (CRD) could be used for make-up. This is possible because SX failures would not disable primary injection systems for several hours, even though diesel generator engine cooling would be lost. During this time, decay heat would decrease to a point at which CRD injection is adequate with no operator action. For these cases, a recovery based on CRD system reliability is added.

In a similar fashion for sequences in which delayed failure of injection systems has occurred and reactor depressurization is available. The fire protection system was applied as an injection recovery source.

3.3.3.2.4 Recovery Sensitivity

NUREG-1335, "Individual Plant Examination: Submittal Guidance" states: "... any sequence that drops below the core damage frequency criteria [of $1E-07$] because the frequency has been reduced by more than an order of magnitude by credit taken for human recovery actions should be discussed [in the IPE submittal]." Therefore, a special sensitivity analysis was done in which any recovery actions with a value of less than .1 was set to 0.1. The total model was requantified with these values. The frequency of each sequence was compared to the frequency for the base case.

The results of this analysis showed that none of the base case probabilities was changed by an order of magnitude. The frequency of one sequence, T5Q2629V (loss of feedwater), increased by a factor of 5.8. Several other sequences increased by less than a factor of 2 and overall cc damage frequency increased by only 4%.

3.3.4 Common-Cause Failure Data

This section discusses the evaluation of component common cause failure probabilities. Common cause failures represent the failure of multiple redundant components from a common failure mechanism. Common cause failure probabilities are treated as basic events in the level 1 Probabilistic Risk Assessment (PRA).

The common cause failure analysis is part of a wider evaluation aimed at analyzing and estimating the effects of dependencies in and among plant systems. Important dependencies are those which compromise the redundancy of a system's ability to prevent or mitigate a severe accident.

The common cause failure analysis identified those dependencies which are not explicitly evaluated in other parts of the PRA. Listed below are dependencies explicitly treated in other phases of the PRA and their method of treatment.

Support System Dependencies - Transfers to support system fault trees are included at appropriate points in system fault trees. Linking fault trees during fault tree reduction and cut set generation ensures such dependencies are expressed correctly in PRA results.

Shared Components Among Front-line Systems - This type of dependency is evaluated correctly by linking fault trees in the sequence quantification phase of the analysis in the same manner as support system dependencies.

Human Errors - Some human error dependencies are included in the common cause failure evaluation. Human errors such as incorrect calibration of sensors or instruments are included as basic events in system models. Human errors such as failure to restore components to service after isolation for maintenance are also explicitly included as basic events in system models. Operator errors occurring subsequent to an accident initiator are explicitly treated in plant sequence models as discussed in Section 3.3.3.1.7.

Maintenance and Testing - Unavailability of multiple components due to preventive maintenance, repair (unscheduled, corrective maintenance), and testing are included as separate events in the system fault tree. However, multiple unavailabilities which are prohibited by technical specifications have been excluded.

External Events - Dependencies among component failures due to the effects of external events (earthquake, fire, external flood, tornado, and heavy wind) are excluded from the PRA at this time. The effects of these events will be evaluated in the Individual Plant Examination for External Events (IPEEE).

The common cause failure analysis involves defining additional basic events that represent common cause failures of components, and adding them to the system fault trees. Common cause events are defined and their probabilities estimated in order to capture the dependency among component failures (both within a system and among separate systems) arising from causes other than those listed above. Some additional causes include common design, manufacturer, installation errors, adverse environment, internal physical similarities such as identical parts, and human errors during maintenance, testing, or operation.

The common cause failure analysis for the CPS PRA used the multiple Greek letter (MGL) model. This model's parameters (the Greek letters beta, gamma, delta, etc.) are defined as conditional probabilities of failure of additional components. For example, the MGL parameter beta is defined as the probability of the common cause failure of two components in a common cause group given that one has failed; gamma is defined as the probability of the common cause failure of three components, given the failure of at least two. The basic event probabilities of the common cause events were the product of the single component failure probability estimated from plant data or generic sources and the MGL estimates.

The component groups for which common cause events were defined are largely those that have proved important in previous PRAs and reliability studies. Table 3.3-11 provides these component groups.

After common cause events were included in the system models, probability estimates were calculated for each event for fault tree quantification and cut set generation. This required analysis of generic industry data to derive parameter estimates for the model.

Table 3.3-12 summarizes the results of the CPS common cause failure analysis. Common cause failure probabilities are derived from the failure rates discussed in section 3.3.1. The common cause failure rates can be per demand or per hour depending on the failure mode.

3.3.5 Quantification of Unavailability of Systems and Functions

Maintenance unavailabilities represent the probability that system trains are inoperable because of the performance of maintenance. Only maintenance activities that can disable the

train's function were considered in deriving these unavailabilities. Plant specific data was used to determine maintenance unavailabilities for the CPS PRA.

Unavailabilities were derived separately for preventive and corrective maintenance so that the effects of either one on core damage frequency can be determined. Preventive maintenance consists of periodic maintenance activities that disable or isolate a train, causing it to be unavailable without recovery actions. Corrective maintenance consists of unscheduled activities that are performed in response to specific problems or conditions noted in the train's components. Corrective maintenance includes both planned and unplanned maintenance activities. Recovery actions are required to return the train to service.

Maintenance unavailabilities are estimated using plant data as the product of average maintenance frequency and average maintenance duration.

The tag out log for the period 10/15/87 through 1/4/92 was the primary source of data used for system unavailability data. The raw data required screening to reduce the data to a set appropriate for estimating unavailabilities. The criteria used to reduce the raw data were as follows:

1. Maintenance performed during cold shutdown was eliminated. Maintenance performed partially during plant operation and partially during cold shutdown was counted, but only the portion performed during plant operation was used in the estimate.
2. Maintenance that did not disable or isolate a train was not counted towards maintenance unavailability estimates.

If no maintenance events were found in the data for a train and performance of preventive or corrective maintenance is possible during plant operation, then the unavailability estimate was based on data from similar trains or systems. For example, estimates for safety-related DC battery chargers preventative maintenance were based on that of non-safety battery chargers because the safety related DC battery chargers have not been removed from service during plant operation.

Table 3.3-13 contains the maintenance unavailabilities used in the PRA which were derived from CPS-plant data.

3.3.6 Generation of Support System States and Quantification of Their Probabilities

Fault trees were developed for support systems required by front-line systems. The effect that support system component failure had on front-line systems and sequences was modeled by linking the support system fault tree directly into the front-line and other affected support systems. The use of the linking process eliminates the need to produce support state event tree models to account for the affects of support systems.

3.3.7 Quantification of Sequence Frequencies

After the system fault trees were completed, minimal cutset equations for the top events were produced. Equations for the functional headings of the fault trees were derived for situations in which combinations of more than one fault tree top event for a given safety function was required. The functional equations for the headings in the level 1 event trees were then combined with the various initiating events to produce core damage frequencies.

The Computer Aided Fault Tree Analysis (CAFTA) program was used to develop and link the fault trees. The personal computer version of Set Equation Transformation System (PCSETS) was used to quantify the fault trees. Cutsets for systems and functions were retained down to $1.0E-09$, with one exception. The low pressure injection function consisting of Low Pressure Core Spray (LPCS), three trains of Residual Heat Removal (RHR), and Condensate/Condensate Booster (CD/CB) systems could be retained to only $7.5E-09$ because of computer limitations. Cutsets for level 1 sequences were retained to $1.1E-09$ because of computer limitations.

The linked fault tree methodology, as used by PCSETS, properly models situations in which the same heading may appear twice in a sequence due to a transfer. The quantification software ensures that the failure of a component is counted only once. For example, in the transient with isolation tree, if SRVs don't open, a transfer to the large break LOCA tree occurs. For this sequence, the question of whether a SCRAM is successful occurs twice, once on the transient with isolation event tree and again on the large break LOCA event tree. The linked fault tree methodology only considers it once.

3.3.8 Internal Flooding Analysis

The Clinton Power Station (CPS) Individual Plant Examination (IPE) internal flooding analysis was conducted to determine the likelihood of core damage sequences initiated by flooding of equipment needed for core cooling or other critical safety functions. Flooding can be initiated by piping leaks, tank overfilling, maintenance errors, mispositioned valves, or pump seal leaks.

Plant locations were included in the flooding analysis if a flood in that location could lead to a SCRAM or shutdown requiring core cooling systems. Plant walkdowns, Sargent & Lundy Report "Internal Flooding Calculations", and input by the IPE Senior Reactor Operator were used to analyze and screen plant locations for vulnerabilities to flooding and determine what equipment would be effected by flooding. The components and systems that could fail if submerged by a flood were identified.

The frequency of flooding at these locations was estimated based on the components (piping, valves, components undergoing maintenance, etc.) that could rupture and cause a flood. If the flood could propagate to other locations, as identified by walkdowns and analysis performed, then components and systems that may be submerged and fail in those locations were also identified. Flood zones in the containment building were not included in this analysis. No safe shutdown system or component could be found that would be disabled by submergence due to any credible flood originating in the containment.

Estimation of the frequency (per year) of a flood in the locations meeting the criteria outlined above was determined by summing the frequency of component failures (pipe breaks, catastrophic valve ruptures, etc.) and the frequency of isolation failures related to maintenance activities. The frequency of component failures was estimated by considering the components in each location using failure data in Table 3.3-14. A section of piping was defined as a run of pipe between major discontinuities (e.g., pumps, valves, etc.). A section of piping may have any number of welds, flanges or bends.

Maintenance data evaluated for each location included activities that opened the system as well as maintenance on electrical components or instruments that did not cause a system breach. The frequency of maintenance activities in a location were derived from the CPS specific maintenance unavailability data for systems and components in a specific location. Since it was not

possible to determine from the data which activities actually breached a system, engineering judgement was used to determine that less than 50% of the maintenance activities would be in this category. The maintenance frequency estimates were multiplied by 0.5 to account for this effect.

The maintenance frequency estimates were also multiplied by an estimate of the probability of an operator failing to isolate the system prior to maintenance. This would create the potential for water to flow from a line that was opened for maintenance. A factor of 0.003 was derived for maintenance on safety systems and 0.01 for balance of plant systems. The difference reflects the more extensive requirements for safety systems.

Also considered was the effect a flood in one location could have on equipment in an adjacent location. If a location was connected to another location that could flood, then it was assumed that equipment in the adjacent location were failed by the flood. Connections that could lead to flood propagation include doorways, hatches, stairwells and shared floor drains. These connections were verified by a review of drawings as well as plant walkdowns. Propagation of flooding from one area to another through an intermediate area or areas was also considered.

For each area, an initiating event was developed for groups of one or more systems in each area. The Plant Service Water (WS) and Plant Chilled Water (WO) systems run throughout the plant. These systems run through locations where no safe shutdown equipment is located. Including an initiating event for each area in the plant for the WS and WO systems would result in unrealistically high flooding frequencies which would distort the flood analysis. If a rupture of a WS or WO line could affect other systems modeled in the IPE, then the analysis was performed as described. A system wide initiator of $1E-03$ per reactor year was included in the model to account for the fact that a rupture in one of these systems could occur in an area where no critical

equipment was located. This is the same frequency used for a small break loss of coolant accident (LOCA) and is conservative because a rupture would probably be isolated before the system was lost.

Upon completion of the flooding initiator analysis, sequence quantification was performed using the internal events sequence results as a basis. Failures postulated to occur as a result of the flood were related to components represented by basic events in the sequence cut sets. Detailed results from the flooding analysis are provided in section 3.4.1.12.

Table 3.3-1

GENERIC COMPONENT FAILURE RATE DATA

Component Type Failure Mode	Failure Rate	Date	Notes
	Estimate (per hour or per demand)	Source	
Pumps:			
Diesel-driven pump fails to run	8E-4/H	NUREG CR-4550 Vol. 1 Rev. 1	
Diesel-driven pump fails to start	5E-2/D	NUREG CR-4550 Vol. 1 Rev. 1	
Motor-driven pump fails to run	3E-5/H	NUREG CR-4550 Vol. 1 Rev. 1	
Motor-driven pump fails to start	3E-3/D	NUREG CR-4550 Vol. 1 Rev. 1	
Turbine-driven pump fails to run (First hour)	5E-3/H	NUREG CR-4550 Vol. 1 Rev. 1	
Turbine-driven pump fails to run (subsequent hours)	2E-5/H	NUREG CR-2815	
Turbine-driven pump fails to start	3E-2/D	NUREG CR-4550 Vol. 1 Rev. 1	
Valves:			
Air-op. valve fails to close	2E-3/D	NUREG CR-4550 Vol. 1 Rev. 1	
Air-op. valve fails to open	2E-3/D	NUREG CR-4550 Vol. 1 Rev. 1	
Air-op. valve plugged	1E-7/H	NUREG CR-4550 Vol. 1 Rev. 1	
Air-op. valve improper transfer	5E-7/H	NUREG CR-4550 Vol. 1 Rev. 1	[1]
Air-op. valve improper closure	1E-7/H	NUREG CR-4550 Vol. 1 Rev. 1	
Check valve fails to close	1E-3/D	NUREG CR-4550 Vol. 1 Rev. 1	
Check valve fails to open	1E-4/D	NUREG CR-4550 Vol. 1 Rev. 1	
Explosive valve fails to open	3E-3/D	NUREG CR-4550 Vol. 1 Rev. 1	
Explosive valve plugged	1E-7/H	NUREG CR-4550 Vol. 1 Rev. 1	
Flow control valve fails to open	3E-3/D	NUREG CR-4550 Vol. 1 Rev. 1	
Hydraulic valve fails to open	2E-3/D	NUREG CR-4550 Vol. 1 Rev. 1	
Hydraulic valve plugged	1E-7/H	NUREG CR-4550 Vol. 1 Rev. 1	
Hydraulic valve improper transfer	1E-7/H	NUREG CR-4550 Vol. 1 Rev. 1	[2]
Motor-op. valve fails to close	3E-3/D	NUREG CR-4550 Vol. 1 Rev. 1	
Motor-op. valve fails to open	3E-3/D	NUREG CR-4550 Vol. 1 Rev. 1	
Motor-op. valve plugged	1E-7/H	NUREG CR-4550 Vol. 1 Rev. 1	
Motor-op. valve improper transfer	5E-7/H	NUREG CR-4550 Vol. 1 Rev. 1	[3]
Safety relief valve fails to open	1E-2/D	NUREG CR-4550 Vol. 1 Rev. 1	
Safety relief valve fails to close	1.6E-2/D	NUREG CR-4550 Vol. 1 Rev. 1	
Relief valve transfer open	3.9E-6/H	NUREG CR-4550 Vol. 1 Rev. 1	
Solenoid valve fails to close	2E-3/D	NUREG CR-4550 Vol. 1 Rev. 1	
Solenoid valve fails to open	2E-3/D	NUREG CR-4550 Vol. 1 Rev. 1	
Solenoid valve plugged	1E-7/H	NUREG CR-4550 Vol. 1 Rev. 1	
Solenoid Valve improper transfer	5E-7/H	NUREG CR-4550 Vol. 1 Rev. 1	[1]
Manual valve fails to close	1E-4/D	NUREG CR-4550 Vol. 1 Rev. 1	[4]
Manual valve fails to open	1E-4/D	NUREG CR-4550 Vol. 1 Rev. 1	
Manual valve plugged	1E-7/H	NUREG CR-4550 Vol. 1 Rev. 1	

Table 3.3-1 (Cont.)

GENERIC COMPONENT FAILURE RATE DATA

Component Type Failure Mode	Failure Rate		Data Source	Notes
	Estimate	(per hour or per demand)		
Electrical Components:				
Battery charger output failure	1E-6/H		NUREG CR-4550 Vol. 1 Rev. 1	
DC bus failure	1E-7/H		NUREG CR-4550 Vol. 1 Rev. 1	
AC bus failure	1E-7/H		NUREG CR-4550 Vol. 1 Rev. 1	
Battery output failure	1E-6/H		NUREG CR-4550 Vol. 1 Rev. 1	
Circuit breaker fails to close	3E-3/D		NUREG CR-4550 Vol. 1 Rev. 1	
Circuit breaker fails to remain closed	1E-6/H		NUREG CR-4550 Vol. 1 Rev. 1	
Circuit breaker fails to open	3E-3/D		NUREG CR-4550 Vol. 1 Rev. 1	[5]
Transformer fails to provide power	2E-6/H		NUREG CR-4550 Vol. 1 Rev. 1	
Diesel generator fails to run	2E-3/H		NUREG CR-4550 Vol. 1 Rev. 1	
Diesel generator fails to start	2E-2/D		Plant Data	
Inverter output failure	1E-4/H		NUREG CR-4550 Vol. 1 Rev. 1	
Instrumentation and Control Components:				
ATM fails (any mode)	1.87E-6/H		GE NSPS Failure Report 19DEC88	
Dig. Sig. cond. fails	1.79E-6/H		GE NSPS Failure Report 19DEC88	
Logic module fails to operate	2.34E-6/H		GE NSPS Failure Report 19DEC88	
Flow switch fails any mode	3E-6/H		NUREG CR-4550 Vol. 1 Rev. 1	[6]
Flow controller fails to operate	1E-4/D		NUREG CR-4550 Vol. 1 Rev. 1	
Temperature Transmitter signal fails	3E-6/H		NUREG CR-4550 Vol. 1 Rev. 1	[6]
Limit switch fails open	6E-6/H		NUREG CR-2815	
Limit switch fails closed	6E-6/H		NUREG CR-2815	
Level switch fails to operate	2.66E-6/H		NUREG CR-4550 Vol. 6 Rev. 1	
Pressure switch fails to operate	2.66E-6/H		NUREG CR-4550 Vol. 6 Rev. 1	
Relay switch fails to operate	3E-4/D		NUREG CR-4550 Vol. 6 Rev. 1	
Static transfer switch fails open	1E-3/D		NUREG CR-4550 Vol. 1 Rev. 1	
Static transfer switch improper transfer	1E-6/H		NUREG CR-4550 Vol. 1 Rev. 1	[7]
Manual Switch Fails	1E-6/H		NUREG CR-2815	
HVAC Components:				
Fan fails to run	1E-5/H		NUREG CR-4550 Vol. 1 Rev. 1	
Fan fails to start	3E-4/D		NUREG CR-4550 Vol. 1 Rev. 1	
Room cooler fails to operate	1.0E-6/H		NUREG CR-4550 Vol. 1 Rev. 1	
Chiller unit fails to run	2.4E-4/H		IEEE-500/1984	
Chiller unit fails to start	3E-4/D		NUREG CR-4550 Vol. 1 Rev. 1	
Damper fails to open	3E-3/D		NUREG CR-4550 Vol. 1 Rev. 1	
Damper fails to close	3E-3/D		NUREG CR-4550 Vol. 1 Rev. 1	

Table 3.3-1 (Cont.)

GENERIC COMPONENT FAILURE RATE DATA

Component Type Failure Mode	Failure Rate	Data	Notes
	Estimate (per hour or per demand)	Source	
Miscellaneous Components:			
Compressor fails to run	2E-4/H	MUREG CR-4550 Vol. 1 Rev. 1	
Compressor fails to start	8E-2/D	MUREG CR-4550 Vol. 1 Rev. 1	
Strainer/filter plugged	3E-5/H	MUREG CR-4550 Vol. 1 Rev. 1	
Strainer motor fails to run	3E-5/H	MUREG CR-4550 Vol. 1 Rev. 1	[8]
Strainer motor fails to start	3E-3/D	MUREG CR-4550 Vol. 1 Rev. 1	[9]
Heat exchanger blockage	5.7E-6/H	MUREG CR-4550 Vol. 1 Rev. 1	
Orifice plugged	6E-7/H	MUREG CR-2815	
Rupture disk fails	3.9E-6/H	MUREG CR-4550 Vol. 1 Rev. 1	[10]
Pipe/component leak	3E-6/H	MUREG CR-4550 Vol. 1 Rev. 1	[11]

Notes to Table 3.3.1:

- [1] Uses "air-operated valve spuriously opens" failure rate.
- [2] Uses "air-operated valve spuriously closes" failure rate as hydraulic valve data were not available.
- [3] Uses "motor-operated valve spuriously opens" failure rate.
- [4] Uses "manual valve fails to open" failure rate.
- [5] Uses "circuit breaker fails to close" failure rate.
- [6] Uses "instrumentation (sensor, transmitter, process switch) failure to operate" failure rate.
- [7] Uses "circuit breaker fail to remain closed" failure rate.
- [8] Uses "motor-operated pump fails to run" failure rate.
- [9] Uses "motor-operated valve fail to open" failure rate.
- [10] Uses "relief valve spurious open" failure rate.
- [11] Uses "heat exchanger rupture" failure rate.

Table 3.3-2

RESTORATION AND CALIBRATION ERRORS

OPERATOR ACTION	FAILURE PROB	DISCUSSION
Failure to restore DG after maintenance	.003	Screening Value
Failure to restore FP pump after maintenance	.003	Screening Value
Failure to restore CD system after maintenance	.003	Screening Value
Failure to restore CB system after maintenance	.003	Screening Value
Failure to restore CP system after maintenance	.003	Screening Value
Failure to restore FW system after maintenance	.003	Screening Value
HPCS not properly restored from maintenance	.003	Screening Value
IA system not properly restored from maintenance	.003	Screening Value
LPCS system not properly restored from maintenance	.003	Screening Value
Failure to restore SX valve F032 after maintenance	.003	Screening Value
ECCS initiation logic division failure to properly restore from maintenance	.003	Screening Value
HPCS initiation logic, failure to properly restore from maintenance	.003	Screening Value
Containment isolation circuit failure to restore from maintenance	.003	Screening Value
Failure to restore DG initiation logic division after maintenance	.003	Screening Value
ARI initiation logic, failure to properly restore from maintenance	.003	Screening Value
RCIC, failure to properly restore from maintenance	.003	Screening Value
Failure to restore LPCI C after maintenance or testing	.003	Screening Value
Failure to restore RK? A or B after maintenance or testing	.003	Screening Value
Failure to restore SLC train after maintenance or testing	.003	Screening Value
VA, VX, VY, VG, VH cooler improperly restored from maintenance	.003	Screening Value
RHR heat exchanger improperly restored from maintenance	.003	Screening Value

Table S.3-2 (Cont'd)

RESTORATION AND CALIBRATION ERRORS

OPERATOR ACTION	FAILURE PROB	DISCUSSION
Failure to restore SX Division A, B, or C after maintenance	.003	Screening Value
DG heat exchanger improperly restored from maintenance	.003	Screening Value
Cooler 1E12C002A, B, or C improperly restored from maintenance	.003	Screening Value
Miscalibration of HPCS flow transmitter	.003	Screening Value
RCIC tank low level transmitter A, C, E, G miscalibrated	.003	Screening Value
Switch OPS-SA038, ZPS-SA038 miscalibrated	.01	Screening Value
Switch IA052, IA053 miscalibrated	.01	Screening Value
Switch 1PSL-SA075 miscalibrated	.01	Screening Value
Switch 1PSL-IA076 miscalibrated	.01	Screening Value

Table 3.3-3

POST-INITIATOR HUMAN INTERACTIONS

OPERATOR ACTION	FAILURE PROB	DISCUSSION
Failure to Initiate RHR Suppression Pool Cooling	.05	Low stress; complex procedure; routine task
Operator failure to open air bottle isolation valve Failure to line up isolated SA Compressor Failure to place SA compressor in standby Operator fails to line up isolated SA dryer Operator fails to line up CC to vacuum pumps Failure to line up vacuum pumps Operator fails to align MS seal steam line Operator fails to align SJAE B	.12	Low stress; simple; routinely performed/practiced
Operators Fail to Shed Battery Loads	.9	High stress
Failure to Start RHR Shutdown Cooling	.003	Low stress; complex procedure; routine task
Operator Fails to Restart RCIC Compressor if Needed	.1	Low stress; simple; outside control room (transients)
	.5	Medium stress; simple; outside control room (LOCA)
Operator fails to Align FP System for Core Injection	.5	High stress; complex
Operator fails to Initiate SLC A&B	.01	High stress; simple; trained upon
Manual Rod Insertion Efforts	1.0	Due to uncertainty regarding effectiveness of this step, given an ATWS

Table 3.3-4

SENSITIVITY ANALYSIS OF IMPORTANT HUMAN INTERACTIONS

OPERATOR ACTION	SCREENING HEP	MAGNITUDE OF HEP CHANGE*	CHANGE IN CORE DAMAGE FREQUENCY	SELECTED FOR DETAILED HRA
Manually Initiating Div I or II SX	5.0E-1	5	1.5E-5	NO
Operator mispositions UPS 1A Bypass Switch	1.0	10	6.1E-6	NO
Operator Fails to Place a Feedpump Back in Service	8.4E-3	3	1.1E-5	YES
Operator Fails to Manually Initiate ADS	2.8E-3	10	6.1E-5	YES
HPCS System Improperly Restored From Maintenance	3.0E-3	3	4.5E-6	NO
Miscalibration of HPCS Flow Transmitter	3.0E-3	3	Approx. 2E-6	NO
Common Cause Miscalibration of RCIC Tank Level Transmitters	3.0E-3	3	4.5E-6	NO
Operator Fails to Restart RCIC Gland Seal Compressor***	1.0E-1	2	1.7E-5	YES
Div 2, Failure to Properly Restore From Maintenance	3.0E-3	3	Approx. 2E-6	NO
Operator Fails to Initiate SLC A & B	1.0E-2	**	**	YES
Failure to Restore SX Division 1A After Maintenance	3.0E-3	3	Approx. 1E-6	NO
Failure to Restore SX Division 2 After Maintenance	3.0E-3	3	Approx. 1E-6	NO
Failure to Restore SX Division 3 After Maintenance	3.0E-3	3	Approx. 1E-6	NO
Common Cause Operator Fails to Manually Open 1SX014A, B, & C	1.0E-1	2	7.3E-6	YES
Room Cooler 1VH075A Improperly Restored from Maintenance	3.0E-3	3	Approx. 1E-6	NO
Room Cooler 1VH075B Improperly Restored from Maintenance	3.0E-3	3	Approx. 1E-6	NO

Table 3.3-4 (Cont'd)

SENSITIVITY ANALYSIS OF IMPORTANT HUMAN INTERACTIONS

OPERATOR ACTION	SCREENING HEP	MAGNITUDE OF HEP CHANGE*	CHANGE IN CORE DAMAGE FREQUENCY	SELECTED FOR DETAILED HRA
Room Cooler 1VH075C Improperly Restored from Maintenance	3.0E-3	3	Approx. 1E-6	NO
Room Cooler 1VY085A Improperly Restored from Maintenance	3.0E-3	3	4.5E-6	NO
DC Load Shedding per CPS 4200.01 Not Successful	9.0E-1	10	1.8E-5	YES

* Screening human error probabilities (HEPs) were divided by the factors in this column to derive new HEPs. The HEPs were used in sensitivity studies to determine the resulting change in core damage frequency.

** No sensitivity analysis performed, Engineering judgement was used to select this event because of its significance in ATWS sequences.

*** Subsequent analysis has determined that loss of the RCIC Bland Seal Compressor does not render RCIC inoperable.

Table 3.3-5

RESULTS OF DETAILED HUMAN RELIABILITY ANALYSIS

	INITIAL SCREENING VALUE	FINAL VALUE
Operator Fails to Initiate SLC A & B	1.0E-2	4.03E-4
Operator Fails to Manually Initiate ADS	2.8E-3	5.0E-4
Operator Fails to Place a Feedpump Back in Service	8.4E-3	5.0E-4
Common Cause Operator Fails to Manually Open 1SX014A, B & C	1.0E-1	2.5E-3
DC Load Shedding per CPS 4200.01 Not Successful	9.0E-1	2.98E-2
Operator Fails to Restart RCIC Gland Seal Compressor	1.0E-1	1.0***

*** Subsequent analysis has determined that loss of the RCIC Bland Seal Compressor does not render RCIC inoperable.

Table 3.3-6

List of Major HRA Events Based
Upon The CPS Sensitivity Analysis

	<u>Basic Event</u>	<u>Description</u>
1.	RSPCOOLSWW	Failure to initiate Residual Heat Removal (RHR) in Suppression Pool Cooling mode
2.	FISIRESTRB	HRA Dependent failure to restore tripped Feedwater (FW) System
3.	GADSMANSYW	Operator fails to manually initiate the Automatic Depressurization System (ADS)
4.	SAS01ABSWW	Operator fails to initiate Standby Liquid Control (SLC) trains A & B
5.	YDCLOADSWH	DC load shedding not successful
6.	B3DGCCDDRI	Failure to recover from the common cause failure of three diesel generator to run in one hour
7.	BDGRUNDDR1	Failure of time phased diesel run in one hour
8.	BISTHPINJR	Operator fails to recover failed High Pressure Core Spray System
9.	BISTRINJR	Operator fails to recover failed Reactor Core Isolation Cooling system
10.	YLI	Failure to recover off-site power within one-half hour of loss
11.	YOSCO04SWH	Failure to recover off-site power within one hour
12.	YOSOTO4SWH	Failure to recover off-site power within four hours

Table 3.3-7

NON-RECOVERY PROBABILITIES FOR SIGNIFICANT BASIC EVENTS

Basic Event Name	Description	Non-Recovery Probability
ADG01KnDGR	.5 hour recovery: Diesel DG01Kn fails to run	.3e
ADG01KnDGR	2 hour recovery: Diesel DG01Kn fails to run	.1e
ADG01KnDGS	.5 hour recovery: Diesel DG01Kn fails to start	.3e
ADG01KnDGS	2 hour recovery: Diesel DG01Kn fails to start	.1e
F1CD020AVC	Condenser overflow valve 1CD020 fails to close	0.90b
F1CD039AVC	SJAE min flow to condenser valve 1CD039 fails to close	0.90b
FCB011nAVC	Condenser flow return valve 1CB011n fails to close	0.90b
FCD031nAVC	Min flow valve 1CD031n fails to close	0.90b
FFW010nAVC	Condenser flow return valve 1FW010n fails to close	0.90b
GCC1312MVO	.5 hr recovery: Common cause failure of ADS containment isol valves 013A/012A to open	0.34c
GCC1312MVO	2 hr recovery: Common cause failure of ADS containment isol valve 013A/012A to open	0.28c
GXCL69SRVD	Common cause failure of at least 6 of 9 SRVs to open	0.33c
HPXC001MPR	HPCS pump fails to run	0.57b
HPXC001MPS	HPCS pump fails to start	0.60b
HPXF004MVO	HPCS Injection valve F004 fails to open	0.34c
HPXF012MVC	HPCS pump min flow valve fails to close	0.34c
HPXF012MVO	HPCS Min flow to supp pool valve fails to open	0.34c
HPXF015MVO	HPCS Suppression pool suction valve fails to open given signal	0.34c
HRITKCCLSZ	Common cause failure of RCIC tank level transmitters to actuate	0.30c
IM035CCLSZ	Common cause failure of RCIC tank level switches to actuate	0.30c
IRIC001TPR	RCIC pump fails to run	0.73c

Table 3.3-7 (Cont'd)

NON-RECOVERY PROBABILITIES FOR SIGNIFICANT BASIC EVENTS

Basic Event Name	Description	Non-Recovery Probability
IRIC001TPS	RCIC pump fails to start	0.73c
IRIF031MVO	RCIC suction valve fails to open	0.34c
IRIF045MVO	Steam supply isolation valve fails to open	0.34c
IRIF068MVO	RCIC Turbine exhaust valve fails to open	0.34c
RABCLCCMPS	Common cause RHR A, B, and C fail to start	0.60b
WSABCCMPR	.5 hr recovery: Common cause failure of WS pumps A, B, and C	0.58b
WSABCCMPR	2 hr recovery: Common cause failure of WS pumps A, B, and C	0.25b
XBPFLCCMVC	RHR heat exchanger bypass flow valve fails to open common cause	0.13c
XDPABCCGTX	Common cause failure Div 1 and 2 discharge pressure instrumentation	0.10c
XDSPRCCGTX	Common cause failure Div. 1, 2 and 3 discharge pressure instrumentation	0.10c
XSX003rMVT	MOV 15X003n fails to remain open	0.13c
XSX004rMVT	MOV 15X004n fails to remain open	0.13c
XSX010nAVC	Discharge Valve 15X010n fails to open	0.36b
XSX01PrMPPR	Pump 15X01Pn fails to run	0.25b
XSX01PrMPPS	Pump 15X01Pn fails to start	0.43b
XSX041nAVO	Discharge valve 15X041n fails to open	0.36b
XSX063nMVO	Discharge valve 15X063n fails to open	0.13c
XSX173nMVO	Min flow valve 15X173n fails to open	0.13c
XSXABCCMPS	Common cause failure of SX A and B pumps to run	0.43b

Table 3.3-7 (Cont'd)

NON-RECOVERY PROBABILITIES FOR SIGNIFICANT BASIC EVENTS

Basic Event Name	Description	Non-Recovery Probability
XXSK02BGTX	Failure of A strainer discharge pressure instrument (SX02B)	0.10c
XXSK030GTX	Failure of B strainer discharge pressure instrument (SX030)	0.10c

- Notes: a Value taken from system category of Electric Power Research Institute (EPRI) RP-3000-34, "Faulted Systems Recovery Experience Draft Report"
- b Value taken from failure mode category of EPRI RP-3000-34
- c Value taken from type of equipment category of EPRI-3000-34

Table 3.3-8

CONDITIONAL PROBABILITIES FOR RECOVERY OF OFF-SITE POWER

Fail to Restore Within (Hrs)	Given not Restored Within (Hrs)	Conditional Probability
.5	0	.421
1	0	.25
2	0	.049
3	0	.036
4	0	.023
5.25	0	.019
6	0	.018
8	0	.012
16	0	.0061
1	.5	.594
5.25	.5	.045
6	4	.78
3	1	.14

Table 3.3-9

TIME-PHASED RECOVERY FOR SHORT TERM STATION BLACKOUT SEQUEL 5 TLU1U2

DESCRIPTION	LEVEL 1 RECOVERY	CONTAINMENT RECOVERY
DG01KA or B fails to run	.2	.34
DG01KC fails to run	.1	.34
Common cause failure of any 2 or all 3 Diesel Generators to run	.1	.34
Diesel A, B, or C fuel oil pump fails	.538	.75
Common cause failure of any 2 or all 3 Diesel fuel oil pumps to start	.12	.47
Common cause failure of any 2 or all 3 Diesel fuel oil pumps to run	.3	.75

Table 3.3-10

TIME-PHASED RECOVERY FOR LONG TERM STATION BLACKOUT SEQUENCE TLU1L4DG1DG2

DESCRIPTION	LEVEL 1 RECOVERY		CONTAINMENT RECOVERY	
	1 HOUR	4 HOUR	1 HOUR	4 HOUR
DG01KA, B, or C fails to run	.14	.191	.52	.87
Common cause failure of any 2 or all 3 Diesel Generators to run	.03	.09	.52	.87
Diesel A, B, or C fuel oil pump fails	.54	.75	.81	.84
Common cause failure of any 2 or all 3 Diesel fuel oil pumps to start	.02	.19	.42	.52
Common cause failure of any 2 or all 3 Diesel fuel oil pumps to run	.0052	.078	.81	.84

Table 3.3-11

COMMON CAUSE COMPONENT GROUPS

1. Diesel generators (failure to start and run)
2. Pumps (failure to start and run)
3. Motor-operated valves (failure to open or close on demand)
4. Circuit breakers (failure to open or close on demand)
5. Batteries
6. Battery chargers
7. Air-operated valves (failure to open or close on demand)
8. Safety relief valves (failure to open or reclose on demand)
9. Check valves (failure to open on demand; failure to remain closed)
10. Instrumentation and control components (failure to send signal or actuate equipment)

Table 3.3-12

COMMON CAUSE FAILURE RATE ESTIMATES

Component/failure Mode	Failure Rate Estimates				per demand (d) or hour (h)	Notes
	Number of Components Failing					
	1	2	3	4		
Diesel generator fails to start	2.9E-2	3.1E-4	2.9E-4	--	d	
Diesel generator fails to run	1.9E-3	5.3E-5	3.4E-5	--	h	
RHR/LPCS pump fails to start	2.7E-3	5.7E-5	0	1.1E-4	d	(1)
RHR/LPCS pump fails to run	2.6E-5	6.1E-7	1.8E-7	1.2E-6	h	
Shutdown service water pump fails to start	2.5E-3	4.4E-4	--	--	d	(2)
Shutdown service water pump fails to run	2.8E-5	1.6E-6	--	--	h	(2)
Standby liquid control pump fails to start and run	2.5E-3	5.0E-4	--	--	d	
Circulating water pump fails to run	2.8E-5	4.0E-7	1.3E-6	--	h	
Check valve fails to open	5.0E-5	5.0E-5	--	--	d	
Check valve fails to close	9.6E-4	4.0E-5	--	--	d	
Air-op. valve fails to operate	1.7E-3	2.9E-4	--	--	d	
Motor-op. valve fails to operate						
6-valve group	2.8E-3	3.7E-5	1.3E-6	7.4E-7	d	(3)
4-valve group	2.8E-3	6.2E-5	4.2E-6	1.1E-5	d	
3-valve group	2.8E-3	9.4E-5	2.1E-5	--	d	
2-valve group	2.0E-3	1.0E-3	--	--	d	
Explosive valve fails to open	2.0E-3	1.0E-3	--	--	d	
Inverter fails to operate						
4-inverter group	8.3E-5	4.3E-6	5.3E-7	2.1E-6	h	
2-inverter group	8.7E-5	1.3E-5	--	--	h	
Battery charger fails to operate						
2-charger group	9.6E-7	3.91E-8	--	--	h	
4-charger group	9.4E-7	1.5E-8	3.2E-9	1.3E-8	h	
Circuit breaker fails to operate (open or close)	2.9E-3	3.2E-5	3.0E-5	--	h	
Relay fails to operate						
2-relay group	2.8E-4	1.7E-5	--	--	d	
3-relay group	2.8E-4	8.3E-6	2.8E-6	--	d	
6-relay group	2.7E-4	3.3E-6	2.6E-7	3.6E-7	d	(4)
Fan fails to start						
3-fan group	2.5E-4	9.4E-6	2.8E-5	--	d	
2-fan group	2.8E-4	2.1E-5	--	--	d	
Fan fails to run						
3-fan group	8.6E-6	2.9E-7	8.6E-7	--	h	
2-fan group	9.4E-6	6.3E-7	--	--	h	
Damper fails to operate (open/close)	2.6E-3	1.4E-4	7.1E-5	--	d	
CD/CB pump fails to run	2.3E-5	--	7.5E-6	--	h	
CD/CB pump fails to start	2.0E-3	--	1.0E-3	--	d	
Solenoid valve fails to open	1.1E-3	1.2E-4	5.4E-4	--	d	
Level switch fails to operate	2.0E-6	3.1E-8	6.9E-9	3.5E-9	h	(5)
Pressure switch fails to operate	1.3E-6	2.2E-8	--	6.7E-7	h	
Level transmitter fails	7.8E-7	4.7E-8	1.7E-8	2.3E-8	h	
Pressure transmitter fails	8.9E-7	2.6E-8	--	2.6E-8	h	

Table 3.3-12 (Cont.)

COMMON CAUSE FAILURE RATE ESTIMATESNOTES

- [1] The 3 RHR pumps and the LPCS pump are grouped together as a component common cause group. No record was found for exactly three pumps failing to start, leading to the MGL parameters estimate of zero.
- [2] Division I and II SX pumps are grouped together as a common cause group. Division III is considered independent, because of its physical separation from the other SX pumps and its substantial difference in size.
- [3] CCF Rate for 5 out of 6 motor-operated valves failing is $4.0E-7$; rate for all 6 out of 6 MOVs failing is $7.2E-6$. These failure rates are per demand.
- [4] CCF rate for 5 out of 6 relays failing is $8.7E-7$; rate for 6 out of 6 failings $5.4E-6$. Rates are per demand.
- [5] CCF rate for 5 of 8 pressure switches failing is $1.7E-9$; rate for 6 of 8 is $1.4E-9$; rate for 7 of 8 is $2.1E-9$; rate for all 8 failing is $1.5E-8$. Rates are per hour.

Table 3.3-13

MAINTENANCE UNAVAILABILITIES
DERIVED FROM CPS PLANT DATA

System/Train	Maintenance Unavailability		Notes
	Corrective	Preventive	
Water Leg Pumps	1.7E-3	2.7E-3	
HPCS (HP)	8.8E-3	6.1E-3	
LPCS (LP)	3.43E-3	1.72E-4	
RCIC (RI)	6.3E-3	4.6E-3	
RHR (RH) (per train)	2.86E-3	5.72E-4	
Diesel Generators	2.63E-2	4.22E-3	
Shutdown Service Water (SX)	7.9E-3	1.7E-3	[1]
Service Air Compressors	1.44E-1	1.8E-2	
Service Air Dryer Trains	8.64E-2	1.1E-2	
Battery Chargers (safety-related)	2.54E-4	1.27E-4	
Battery Chargers (non-safety)	1.0E-3	7.6E-4	
Batteries (non-safety)	7.5E-3	1.5E-3	
Batteries (safety-related)	3.8E-3	5.1E-4	
DC Bus (safety-related)	1.9E-4		
DC Bus (non-safety)	3.8E-4		
Inverters	8.8E-5		[2]
Turbine Building Closed Cooling Water (WT)	1.4E-2	5.0E-3	
Condensate (CD)	7.8E-2	9.5E-3	
CD Train	1.3E-1	5.8E-3	
Component Cooling Water (CC)	2.6E-2	5.8E-3	
Condensate Booster (CB)	5.1E-2	1.4E-2	
CB Drain Cooler	2.0E-3		
CB Heaters 2-5	2.0E-3		
CB Train	9.5E-2	2.1E-2	
Condensate Polishers (CP)	5.1E-4	5.6E-5	
Plant Service Water (WS)	3.5E-2	5.1E-4	
WS Water Seal Pumps	5.6E-2	7.5E-3	
Plant Chilled Water (WO)	5.6E-2	5.6E-3	
Feedwater Pump Trains (motor-driven)	6.0E-2	1.03E-3	
Feedwater Pump Trains (turbine driven)	1.1E-2	3.4E-4	
Circulating Water (CW)	1.9E-2	2.3E-3	
Fire Protection (FP)	1.54E-1	1.72E-3	
Condenser Vacuum Pumps	1.5E-2	1.0E-2	
Steam Jet Air Ejectors	2.3E-3		
Off-Gas Dryer Trains	3.84E-2		
Automatic Depressurization System	8.6E-4		

Table 3.3-13 (Cont.)

MAINTENANCE UNAVAILABILITIES
DERIVED FROM CPS PLANT DATA

Notes to Table 3.3-13:

- [1] SX filter PMs not included because of the existing bypass capability. Unavailability would be $1.25E-2$ if these PMs were included.
- [2] No maintenance events (PM or CM) recorded in plant records. See calculation for unavailability estimate deviation.

Table 3.3-14

INTERNAL FLOODING EVENT DATA

Component	Failure Mode	Failure Rate	Sources
Air Operated Valve	Rupture	2.0E-7/hr	NUREG/CR-1363 (BWR)
Manual Valve	Rupture	3.0E-8/hr	NUREG/CR-1363 (BWR)
Motor-Operated Valve	Rupture	8.0E-8/hr	NUREG/CR-1363 (BWR)
Check Valves	Rupture	8.0E-8/hr	NUREG/CR-1363 (BWR)
Tank	Rupture	2.7E-8/hr	Seabrook PRA
Piping (>3" Diameter) (<3" Diameter)	Rupture	3.5E-10/section-hr 8.5E-9/section-hr	WASH-1400 WASH-1400
Expansion Joints	Rupture	2.5E-4/expansion joint-year	Oconee 3 PRA

3.4 Results and Screening Process

This section summarizes the overall findings from the quantification of the Clinton Power Station (CPS) front-end analysis (level 1 probabilistic risk assessment). Detailed descriptions of the dominant functional accident sequences are provided in this section. Dominant functional sequences are represented by accident class and subclasses as defined in Section 3.1.5. Table 3.4-1 contains a summary of core damage frequency (CDF) by accident classes. Specific items discussed for each sequence are as follows:

1. Description of accident progression, event timing, and containment failure mode applicable.
2. Efforts which were made to make assumptions consistent with the best-estimate information and assumptions to which the results are sensitive.
3. Significant initiating events, human actions, and sensitive parameters.

The Individual Plant Examination (IPE) results focused on plant design features and operating characteristics most important to preventing core damage.

The total CDF for CPS resulting from internal events and internal flooding is $4.6E-05$ per reactor year. Core damage is defined as reactor level less than two thirds the length of active fuel for more than 4 minutes or Modular Accident Analysis Program results with fuel temperature of 2200°F or more. The Critical Safety Function success criteria are discussed in Section 3.1.2.1.

3.4.1 Application of Generic Letter Screening Criteria

The screening criteria contained in Appendix 2 of Generic Letter 88-20, "Individual Plant Examination for Severe Accident Vulnerabilities", was used to determine those accident sequences to be discussed in this section. The screening criteria are as follows:

1. Functional sequences with a core damage frequency greater than $1.0E-07$ per reactor year. The functional sequences are grouped into accident classes. Within each accident damage class, sequences were generally identified by the dominant initiating events.
2. Functional sequences that contribute 5% or more to CDF. Any sequence greater than $1.2E-06$ per reactor year will be discussed. This criteria is enveloped by criterion 1 above.
3. Sequences determined by Illinois Power Company to be important contributors to CDF.

These screening criteria meet the requirements of NUREG 1335, and the sequences that meet this criteria are contained in Table 3.4-2. Sequences below the screening value of $1.0E-07$ were also reviewed to determine if any sequences had interesting insights or differed substantially from the dominant sequences. There are some sequences above $1.0E-08$ that are due to loss of a non-safety DC bus or anticipated transient without SCRAM (ATWS) but no new insights were gained. No additional sequences were found that met this criterion. The results of all sequences are included in the event trees (Figures 3.1-1 through 3.1-17).

The following is a brief discussion of the sequences in Table 3.4-2:

3.4.1.1 Class 1A

The sequences in this class include a loss of high pressure inventory makeup (U2,U) with a failure to depressurize the reactor vessel (X1). These sequences are typified by the symbols T,U2,U and X1 from the failure headings of the event trees presented in Section 3.1. Class 1A sequences had a total core damage frequency (CDF) of $9.8E-06$ per reactor year or 37% of the internal events CDF, including internal flooding.

Significant initiating events contributing to the class 1A CDF were transient without isolation (41%), transient with isolation (40%), loss of off-site power (12%), and loss of Feedwater (FW) (7%).

For these sequences, reactivity control was successful (event tree heading C1) and the safety relief valves cycled (event tree headings M and P) to control reactor vessel pressure. Loss of the main condenser as a heat sink was the first functional failure that occurred for the transient without isolation event (event tree heading Q2). The event trees proceed in the same path for the remainder of the initiating events in this class. Loss of high pressure injection is the next failure that occurs. FW, Reactor Core Isolation Cooling (RCIC), and High Pressure Core Spray (HPCS) are unable to perform their safety function which is to maintain reactor water level because of equipment failure or maintenance unavailability (event tree headings U2 and U). Failure of high pressure injection sources requires that the reactor vessel be depressurized when water level reaches the top of active fuel so that low pressure injection sources can restore water level. Operator action is required to depressurize the vessel since the emergency operating procedures (EOPs) require the operator to inhibit the Automatic Depressurization System (ADS) once the timer starts. However, in this sequence, depressurizing the reactor is not successful. Control Rod Drive (CRD) is providing makeup in the post-SCRAM mode. CRD alone can

not supply sufficient makeup to keep the core covered unless high pressure systems operate successfully for a period of time. Without sufficient high capacity injection, water level will steadily decrease due to cycling of the SRVs until the core is uncovered and fuel damage occurs. Containment is intact at this point. Without reactor depressurization and high pressure injection other than CRD, active fuel will be uncovered in approximately 28 minutes. If CRD is not available, then fuel would be uncovered in approximately 25 minutes.

Assumptions applicable to this class are as follows:

1. ADS is always inhibited by the operators as directed by EOPs. Inhibiting ADS, which makes depressurization a manually controlled action, is considered a conservative bounding assumption.
2. HPCS and RCIC were not recovered before core damage occurred.
3. The end state involves reactor water level below the top of active fuel, which is the initiation of core damage. This point was reached between 25 and 32 minutes after the initiating event occurred depending on whether or not CRD is available for injection. Core damage was assumed to occur at this point, with containment intact. No environmental conditions of concern existed within containment at the point of core damage.

4. Failure of the rapid recovery of FW following the loss of FW initiating event was based on the experience at other operating plants. This data shows that of 14 loss of FW events, 11 were immediately recovered from the control room.
5. The main steam isolation valves (MSIVs) close on a low-low reactor water level (level 1).
6. FW availability during manual shutdown or turbine trip is conservatively modeled. The Turbine Driven Reactor Feedpumps (TDRFP) are not included in the model. Only the Motor Driven Reactor Feedpump (MDRFP) is available to provide high pressure makeup through FW.
7. The potential for recovery of off-site power within a half hour is considered for loss of off-site power events. If recovery is successful, then the analysis continues as a transient with isolation event and FW can also be recovered.
8. ADS is assumed to be available for four hours after a loss of off-site power initiating event provided the following occurs:
 - a) The back up air bottles are manually valved in. This operator action is shown as a basic event in the model.
 - b) If off-site power is restored, then the accumulators can be recharged using Instrument Air (IA).
9. A loss of a non-safety DC bus results in a loss of FW and a reactor SCRAM.

5.4.1.2 Class 1B

Sequences in this class were characterized by a loss of off-site and on-site AC power and a loss of coolant inventory makeup. In addition to those events initiated by a loss of off-site power (LOOP), other initiating events combined with a subsequent random LOOP are included in this class. This is conservative in that in the event of a LOOP occurring several hours after the initial SCRAM, core decay heat loads would be much lower than immediately following the SCRAM and much longer recovery times would be available. These sequences were combined this way to facilitate the modeling of off-site power recovery. Following a LOOP, the division 1, 2, and 3 diesel generators receive a start signal. If both division 1 and 2 diesel generators fail to start or start and fail to run, then a station blackout (SBO) occurs. This is the definition of SBO contained in Nuclear Management and Resources Council (NUMARC) 87-00, "Guidelines and Technical Basis for Addressing Station Blackout at Light Water Reactors".

Class 1B sequences make up approximately 37% of the total internal event core damage frequency (CDF), including internal flooding, with a CDF from all Class 1B sequences of $9.8E-06$ per reactor year.

The SBO event tree is entered from the LOOP tree. A SCRAM and initial pressure control have already successfully occurred. If off-site power is not promptly recovered and the division 1 and 2 diesel generators fail to start or run, then the SBO event tree is entered.

The first functional failure that occurs is the loss of high pressure injection (event tree headings U1 and U3). The first systemic failure is failure of the High Pressure Core Spray (HPCS) system. This could be from the unavailability of the system because of maintenance or the failure of the division 3 diesel generator to start or run. A component failure in the HPCS system could also occur. The next systemic failure would be the failure of the Reactor Core Isolation Cooling (RCIC) system. This would occur if the batteries were depleted, the batteries or the RCIC system were unavailable due to maintenance, or a failure occurred in either the RCIC or DC system. Water level in the reactor would reach top of active fuel between 25 minutes and 5.25 hours depending on the length of time between the initiating event and the failure of RCIC.

The next functional failures evaluated are recovery actions (event tree headings L4, DG1, and DG2). Core damage occurs because RCIC has failed due to an equipment failure or depletion of the batteries, and neither off-site power nor the division 1 or 2 diesel generators are recovered. Therefore no core cooling systems are available.

Assumptions applicable to this class are as follows.

1. If AC power to the battery chargers is not available, then the batteries will eventually be depleted. No credit in the model is taken for replacing the batteries with other charged batteries.
2. The batteries are assumed to be available for four hours if load shedding is performed by the operators in one hour. If load shedding is not performed, then the batteries are assumed to fail after one hour.
3. Low pressure injection systems are not available unless the off-site power is recovered, because air supplies for opening the SRV's to depressurize the reactor vessel would be depleted. The off site power or division 1 or 2 diesel generators need to be recovered to provide a power source for the low pressure injection systems.
4. If a random failure of HPCS and RCIC occurs early in the event, then level would reach top of active fuel in approximately 25 minutes after the initiating event.
5. If RCIC is initially available, then after the batteries are depleted and if HPCS is not available, the level would reach top of active fuel in approximately 1.25 hours.
6. The diesel driven fire pumps could be used as a low pressure injection source. However, since it takes several hours to align for reactor injection, it is not modeled for this event (see #3 and section 3.1.2.3).

3.4.1.3 Class 1C

Sequences in this class were characterized by an Anticipated Transient Without SCRAM (ATWS) with a coincident loss of all inventory makeup. All events in this class were included in the analysis for class IV, section 3.4.1.10.

3.4.1.4 Class 1D

Sequences in this class were characterized by an initiating transient with successful reactor depressurization but both high and low pressure inventory makeup systems are lost. Class 1D sequences contributed 22% to the core damage frequency (CDF) at Clinton Power Station (CPS). The CDF, including internal flooding, is 5.7E-6 per reactor year.

Significant initiating events for the class 1D accident class include loss of a non-safety DC bus (21%), loss of off-site power (24%), transients without isolation (20%), transients with isolation (9%) and loss of feedwater (7%).

These accident sequences proceed similar to the Class 1A sequences except that depressurization is successful and after depressurization the low pressure injection systems also fail so that no makeup is available. Emergency operating procedures (EOPs) direct the operators not to depressurize the reactor until level is below the top of active fuel so the time to core damage is the same as high pressure events (approximately 25 to 32 minutes depending on the status injection from the of Control Rod Drive (CRD) system).

Assumptions associated with this class are as follows:

1. Shutdown Service Water (SX) could be aligned to provide low pressure makeup through the Residual Heat Removal (RHR) system. This source of injection is not modeled.

2. Diesel driven fire pumps can be aligned to provide reactor vessel inventory makeup. However, since it takes several hours to align the fire pumps in this mode, this is included only as a recovery after some other system successfully operated for some period of time.
3. CRD can provide makeup to preclude core damage only if other systems have been removing decay heat for a period of time.
4. If off-site power is recovered in 30 minutes then analysis continues as a transient with isolation event.

3.4.1.5 Class II

Events in this class are characterized by a loss of containment heat removal. Analysis has shown that the Emergency Core Cooling System (ECCS) pumps can take suction from the suppression pool even under saturation conditions. This is discussed further in section 3.1.2.2, assumption 1. Therefore this class of accident is not applicable to CPS.

3.4.1.6 Class IIIA

This class contains accident sequences involving reactor vessel rupture and the failure of ECCS injection systems. Containment remains intact after the rupture. These events were evaluated as a large break loss of coolant accident (LOCA) as a Class IIIC sequence.

3.4.1.7 Class IIIB

This class contains accident sequences resulting from small or medium LOCAs for which the reactor is not depressurized and inadequate coolant inventory makeup is available.

This class contributed much less than 1% of the CDF with a CDF of $1.3E-08$ per reactor year. This is far below the criteria and CPS does not consider the possibility of a LOCA and all SRVs failing to open to be a significant contributor.

3.4.1.8 Class IIIC

Accident sequences resulting from LOCAs for which reactor depressurization is caused by the event or is successful. Inadequate coolant inventory makeup is available from Emergency Core Cooling Systems (ECCS), RCIC, or Feedwater Delivery systems.

This class contributed approximately 4% of the total CDF with a CDF of $1.1E-06$ per reactor year. The main contributor is an inadvertent/stuck open relief valve (IORV). The remaining sequences contribute less than $1.0E-09$ per reactor year to the overall CDF.

The important sequence in this class was characterized by an initiating event and a successful reactor SCRAM (event heading C1). The first functional failure which occurs is the loss of high pressure injection systems (event heading Q1 and U1). Both HPCS and the FW delivery systems fail. If either system succeeds, then core damage is averted. The next functional failure is failure of low pressure injection (event heading V). This includes all three trains of LPCI, LPCS, CD and CB. If all these systems fail, then core damage occurs.

Assumptions associated with this class are as follows:

1. RCIC does not have sufficient capacity to maintain coverage of the core.
2. The reactor does not need to be depressurized for low pressure coolant injection since the opening of one SRV is sufficient to depressurize the reactor.

3. Core damage occurs between twenty-five and thirty-two minutes after the initiating event, depending on the status of CRD as an injection source.
4. Diesel driven fire pumps can be aligned to provide reactor vessel inventory makeup. However since it takes several hours to align the fire pumps in this mode, this is included only as a recovery for long-term failures.

3.4.1.9 Class IIID

This class contains accident sequences initiated by a large break LOCA or reactor vessel rupture for which containment heat removal was inadequate. Large break LOCAs were evaluated in Class IIIC.

3.4.1.10 Class IV

This class contains accident sequences involving an ATWS leading to containment failure due to high pressure and core damage resulting from subsequent loss of inventory makeup.

These sequences contributed less than 1% of the total CDF with a frequency of $1.4E-07$ per reactor year. Since the individual sequences which contribute to this CDF are less than $1.0E-07$ this class will not be further discussed here. It should be noted that a significant percentage of containment failures result from ATWS events (see section 4.6).

3.4.1.11 Class V

This class contains accident sequences involving an unisolated LOCA outside containment coupled with the loss of inventory makeup. These sequences contributed much less than 1% of the

total CDF and were outside the screening criteria and will not be further discussed here.

3.4.1.12 Internal Flooding

The CPS IPE internal flooding analysis was conducted to investigate the likelihood of core damage sequences initiated by flooding of equipment needed for core cooling or other critical safety functions. Areas of the plant that contain equipment which meet the above criteria were analyzed to determine the likelihood of flooding and the affect on core damage frequency. Piping and components in these areas were analyzed to determine which failures could contribute to flooding. This analysis is discussed in detail in Section 3.3.8.

The total core damage frequency (CDF) for internal flooding events is estimated at $1.6E-06$ per reactor year. This represents approximately 6% of the total core damage frequency. Table 3.4-3 contains the five most significant sequences.

Each of these five sequences is discussed below:

3.4.1.12.1 Feedwater Line Break in the Main Steam Tunnel

A Feedwater (FW) line break in the main steam tunnel has the highest internal flooding core damage frequency and constitutes approximately 25 percent of the CPS internal flooding core damage frequency. The CDF from this scenario is $4.17E-07$ per reactor year. This scenario involves a loss of FW injection and potentially affects Emergency Core Cooling System (ECCS) equipment located below the main steam tunnel. A two inch space between the containment wall and the floors and walls of auxiliary building allows water discharged from a line break to drain to the Reactor Core Isolation Cooling (RCIC) pump room. A conservative assumption was made that the gap is of sufficient

size so that flow to the RCIC room is not limited. Other paths allow water to flow into the Low Pressure Core Spray (LPCS) and the "A" Residual Heat Removal (RHR) pump rooms. Calculations reveal that if all the water from a FW line break entered only one room, the depth of the water would be 44 inches in the RCIC room, or 42 inches in the LPCS room, or 35 inches in the RHR "A" room. This is a conservative assumption because it assumes the entire inventory fills one room. The FW inventory would actually be distributed among the three rooms with most of the inventory located in the RCIC room.

Operators are not expected to quickly diagnose a FW line break. A variety of annunciators require diagnosis to reach this conclusion. This is based on simulator observations during FW line break scenarios. Emergency operating procedures (EOPs) do not require a FW isolation unless a line break is diagnosed by the operator. It is likely, therefore, that this diagnosis would take longer than the time to flood the RCIC room to the critical height of 42". This height is critical because it is the height of the RCIC lube oil cooler inlet motor operated valve. Therefore, RCIC is conservatively assumed to fail before FW is isolated.

The critical height for LPCS and RHR "A" pump rooms is nine feet which is much higher than the calculated flood level. During the initial flood analysis, it was assumed that LPCS and RHR "A" failed because of the flood. The core damage frequency for this flood scenario was recalculated assuming that LPCS and RHR "A" did not fail. No appreciable difference in core damage frequency was found since the major effects of the scenario are loss of FW, Condensate Booster (CB), Condensate (CD), and RCIC.

3.4.1.12.2 Component Cooling Water (CC) line Break or
Maintenance Error in the CC Pump and Tank Room

This flood scenario had a high CDF estimate due to a high initiation frequency estimate. The initiating frequency was dominated by maintenance errors during Component Cooling Water (CC) pump maintenance. This requires the failure to close a CC pump manual isolation valve (suction or discharge) prior to maintenance activities which open the system. Further analysis indicates that if this occurred, maintenance personnel could be in close proximity to the pump and would immediately detect the flood. It is also highly likely that the maintenance personnel would shut the isolation valves which are located close to the pumps.

Calculations indicate that water would reach a level of 5 inches one hour after the initiation of the flood. It is highly likely that a flood initiated by a maintenance error would be detected and recovered before water reached the level that would fail CC components. Therefore, maintenance errors were removed from the flood initiator for this area. The revised flood initiator frequency is $1.3E-02$ per reactor year and the revised core damage frequency is $1.55E-07$ per reactor year.

The major contribution to core damage for this flood initiator is loss of the Instrument Air (IA) compressors since CC cools the IA compressors. Loss of IA leads to loss of FW and main steam isolation valve (MSIV) closure.

3.4.1.12.3 Plant Service Water (WS) Line Break in the CC
Pump/Tank Area.

A break in a Plant Service Water (WS) line in the CC pump/tank area has an initiator frequency of $1.4E-03$ per reactor year.

This results in a CDF of $2.24E-07$ per reactor year. The primary effect from this initiator is the same as in Section 3.4.1.12.2, loss of the IA compressors because of a loss of CC.

3.4.1.12.4 Pipe Ruptures in the High Pressure Core Spray (HPCS) Pump Room

There are two dominant sequences which result in a flood in the High Pressure Core Spray (HPCS) room. They are a break in a Plant Service Water (WS) pipe or a break in a HPCS pipe. Floods in this room are important because the loss of HPCS significantly affects the core damage frequency. Upon detection of a WS line break, it is expected that the operator would begin tripping WS pumps to mitigate the line break. If an unisolable leak occurred, all the running pumps would be tripped, resulting in a loss of WS. Loss of WS affects other potential core cooling sources such as FW, CD, and Control Rod Drive (CRD) because WS provides a source of cooling for these systems. The loss of WS also affects the probability of losing other ECCS systems, because WS is a back up to Shutdown Service Water (SX) system.

A line break in the HPCS pump room results in a complete loss of HPCS because the break may not be isolable. If the break occurs on the HPCS suction line between the containment wall and the first isolation valve, the leak is not isolable and the room would flood with suppression pool water.

A break in a WS system pipe has an initiating event frequency of $8.2E-05$ per reactor year resulting in a CDF of $2.23E-07$ per reactor year. A break in a HPCS system pipe has an initiating event frequency of $1.3E-02$ resulting in a CDF of $1.79E-07$ per reactor year.

The above described internal flooding analysis addresses the resolution of unresolved safety issue A-17. This was closed by generic letter 89-18 with the suggestion that licensees review potential water intrusion and internal flooding as part of the IPE.

3.4.2 Vulnerability Screening

An analysis was performed to determine if any new vulnerabilities were discovered as a result of the Individual Plant Examination (IPE). The criteria used to determine if vulnerabilities exist are as follows:

1. Are there any new or unusual means by which core damage or containment failure occur as compared to those identified in other probabilistic risk assessments (PRAs)?
2. Do the results suggest that the Clinton Power Station (CPS) core damage frequency would not be able to meet the Nuclear Regulatory Commission's (NRC) safety goal for core damage?
3. Are there any systems, components, or operator actions that control the core damage result (i.e., greater than 90%)?

None of these criteria lead to the identification of potential vulnerabilities for CPS. The accident classes that contribute to the potential for core damage are similar to those identified in probabilistic risk assessments (PRAs) of comparable facilities such as NUREG/CR-4550, "Analysis of Core Damage Frequency Grand Gulf, Unit 1-Internal Events". Also, while it does not include the contribution from external events, the overall core damage frequency of $2.6E-05$ per reactor year is less than the NRC's safety goal for core damage of $1E-04$ per reactor year. This leaves ample margin for accommodating risks of other events such as earthquakes or fires.

Another term frequently used is "significant insight". In general, a significant insight is a system, component, or action which influences the results of this study more than other events. A significant insight may involve any of the following:

1. A unique safety feature which significantly drove risk either by limiting the potential for or contribution to core damage.
2. A system interaction effect which had a relatively important impact on the overall results of this study.
3. A component failure mode or operator action which had a significant impact on the results of an accident class or the overall results.
4. A failure or operator action worthy of consideration of a recommendation.
5. A critical operator action which had limited procedural guidance.

Detailed discussion of insights discovered during the performance of the CPS IPE are presented in Chapter 6.

3.4.3 Decay Heat Removal Evaluation

3.4.3.1 Introduction

An evaluation of decay heat removal capabilities has been performed as part of the Clinton Power Station (CPS) Individual Plant Examination (IPE). The purpose of this evaluation is to identify potential decay heat removal vulnerabilities that may exist during 24 hours after a plant trip and to examine whether

or not risks associated with the loss of decay heat removal can be lowered in a cost effective manner. This evaluation is required by Generic Letter 88-20, "Individual Plant Examination for Severe Accident Vulnerabilities".

Following is a brief discussion of the decay heat removal functions at CPS.

3.4.3.2 Discussion

Decay heat removal during the first twenty-four hours after a plant trip is accomplished by the following key functions.

1. After a plant trip without isolation of the main steam lines initiator, decay heat is removed through the main condenser. This is accomplished with the Main Steam (MS) and Feedwater (FW) delivery systems (Condensate (CD), Condensate Booster (CB) and FW). After the reactor has been depressurized the Residual Heat Removal (RHR) system is placed in the shutdown cooling mode.
2. After a plant trip due to a transient with isolation initiator, the MS and FW delivery systems will not be available to remove decay heat, RHR in the shutdown cooling mode would be used to remove decay heat after the reactor is depressurized using safety relief valves (SRVs) or Reactor Core Isolation Cooling (RCIC). If the reactor can not be depressurized, then RCIC along with Control Rod Drive (CRD) is used to remove decay heat. Either train of RHR would need to be in the suppression pool cooling mode sometime after RCIC is started.
3. After a loss of off-site power initiator, decay heat is removed as in the transient with isolation scenario. If the division 1 and 2 diesels fail to start, then RCIC is used to

remove decay heat. RCIC is successful for four hours if DC loads are shed by the operators within 1 hour of the initiator.

4. The safety relief valves (SRVs) can be used to remove decay heat to the suppression pool. A source of reactor makeup water such as RCIC, High Pressure Core Spray (HPCS), Low Pressure Core Spray (LPCS), etc, would be used. If RHR were not available in the suppression pool cooling mode, then heat from the containment would be removed by containment spray or venting.

3.4.3.3 Methodology

The results of the level 1 analysis were used to evaluate the potential for loss of decay heat removal. The cutsets for the overall core damage frequency were used in this analysis. Failure of systems which cannot remove decay heat were eliminated from the model. These systems include HPCS, RCIC, LPCS, Automatic Depressurization (ADS), and Fire Protection (FP). The resulting core damage frequency due to loss of decay heat removal is estimated at $5.2E-06$ per reactor year.

Additional methods to remove decay heat such as Reactor Water Cleanup (RWCU) blowing down to the main condenser and RHR lined up through the Fuel Pool Cooling and Cleanup (FC) system heat exchangers were not included in the model. Therefore the model used for the loss of decay heat removal evaluation is conservative. If these additional methods of decay heat removal were added, the core damage frequency due to loss of decay heat removal could be reduced further.

3.4.3.4 Conclusions

Unresolved Safety Issue A-45, "Shutdown Decay Heat Removal Requirements", recommends that core damage frequency because of failures of the decay heat removal systems should not be greater than $1E-05$ per reactor year. This analysis shows the core damage frequency due to the loss of decay heat removal at CPS is no greater $5.2E-06$ per reactor year. No vulnerabilities were discovered during this analysis. Since the CPS core damage frequency is much less than the target recommended by the Nuclear Regulatory Commission (NRC), no cost effective measures to further reduce the core damage frequency are anticipated.

3.4.4 Unresolved Safety Issue and Generic Safety Issue Screening

Other than Unresolved Safety Issue (USI), A-45, Shutdown Heat Removal Requirements, just discussed, there are no open Generic Safety Issues (GSI) for the Clinton Power Station. This USI was discussed in the previous section.

Table 3.4-1

Core Damage Frequency by Accident Class

<u>Accident Class</u>	<u>Core Damage Frequency*</u>	<u>Percent of Total</u>
Transients - high pressure (IA)	9.8E-06	37%
Station Blackout (IB)	9.8E-06	37%
Transients - low pressure (ID)	5.7E-06	22%
LOCAs - high pressure (IIIB)	1.3E-08	0%
LOCAs - low pressure (IIIC)	1.1E-06	4%
ATWS events (IV)	1.4E-07	1%
Containment bypass (V)	<1.0E-09	0%
Overall Core Damage Frequency	2.6E-05	

* Per reactor year

Table 3.4-2
Accident Sequences Contributing to
Core Damage Frequency Which Meet
the Screening Criteria

<u>Accident Class</u>	<u>Accident Sequence</u>	<u>Core Damage Frequency*</u>	<u>Type</u>
IA	T2U2UX1	3.4E-6	Transient Without Isolation
	T3U2UX1	3.0E-6	Transient With Isolation
	TPL1U2U1X1	8.6E-7	Loss of Off-Site Power
	T5Q2U2UX1	1.8E-7	Loss of Feedwater
IB	TLU1U3	5.2E-6	Short-Term Station Blackout
	TLU1L4DG1DG2	4.6E-6	Long-Term Station Blackout
ID	DCQ2U2UV	1.1E-6	Loss of Non-Safety D.C. Bus
	TPL1U2U1V	7.7E-7	Loss of Off-site Power
	TPL1WU1V	5.7E-7	Loss of Off-site Power
	T2Q2U2UV	6.0E-7	Transient Without Isolation
	T2Q2WUV	5.0E-7	Transient Without Isolation
	T3WUV	2.8E-7	Transient With Isolation
	T5U2UX1	4.6E-7	Loss of Feedwater
	T5Q2WUV	3.5E-7	Loss of Feedwater
	III	LOQU1V	1.06E-6

* Per Reactor Year

Table 3.4-3

Internal Flooding
Dominant Core Damage Sequences

<u>Flood Location Description</u>	<u>Core Damage Frequency (per reactor year)</u>
Feedwater Line Break in Main Steam Tunnel	4.17E-07
Component Cooling Water (CC) Line Break in the CC Pump and Tank Area (Control Building Elevation 762)	1.55E-07
Plant Service Water (WS) Line Break in CC Pump and Tank Area	2.24E-07
WS Line Break in High Pressure Core Spray (HPCS) Pump Room	2.23E-07
HPCS Line Rupture in HPCS Pump Rooms	1.79E-07

HIS PAGE

INTENTIONALLY

LEFT BLANK

4. BACK-END ANALYSIS

The previous sections of this report have described the methods used to arrive at the probability of core damaging events and the actions and events that are most likely contributors. This section describes the "back-end" analysis, that is, the process of obtaining an understanding of potential challenges to the containment. This analysis evaluates the role of plant features and the effects of phenomena in preventing or mitigating challenges to containment integrity and limiting off-site releases. The impact of operator actions when dealing with challenges to the containment is also considered in the level 2 analysis.

The Clinton Power Station (CPS) containment analysis results show that the containment is particularly robust with a low conditional failure frequency and source term release as detailed in Section 4.7. Several significant factors contribute to this conclusion. First, the containment pressure capacity is very high (93.8 psig - see Section 4.4.9) with respect to other BWR-6s. Second, the CPS containment is very large with respect to the thermal rating of the reactor. Third, the suppression pool volume is also large with respect to the thermal rating of the reactor. Table 4-1 compares these factors.

Table 4-1

Comparison of BWR-6 Containment Capacities

	<u>CPS</u>	<u>PERRY</u>	<u>GRAND GULF</u>	<u>RIVER BEND</u>
Estimated Containment Failure Pressure (psig)	93.8	64	67	63
Containment Free Volume/Thermal Power Rating (ft ³ /kw)	.62	.399	.36	.501
Suppression Pool Volume/Thermal Power Rating (ft ³ /kw)	.047	.033	.035	.044

The CPS and Grand Gulf containment designs are similar in that both are steel lined, reinforced concrete structures. The River Bend and Perry containments are free-standing steel structures. The most notable difference between the CPS containment and the Grand Gulf containment, other than those identified above, is that Grand Gulf used number 18 reinforcing steel on 18 inch centers and CPS used number 18 reinforcing steel on 12 inch centers.

4.1 Plant Data and Plant Description

This section describes the containment geometry and that of other structures internal to containment that are important in assessing severe accident progression. A discussion of systems and assumptions regarding operability of equipment in harsh environments is also provided. Table 4.1-1 tabulates some important dimensions and capacities for the containment, drywell and suppression pool.

4.1.1 Clinton Power Station Containment

CPS is a General Electric BWR-6 rated at 2894 Mwt with a Mark III containment as shown in Figure 4.1-1. This design incorporates a large pool of water, the Suppression Pool, for condensing steam from the reactor vessel relief valves and from postulated pipe breaks.

The containment consists of a right circular cylinder, 124 feet inside diameter, with a hemispherical domed roof and a flat base slab. The containment wall is constructed of reinforced concrete, completely lined internally with 1/4 inch thick steel plate. The lower section of the containment wall acts as the outer boundary of the suppression pool. Two double-door airlocks provide for personnel access and a sealed equipment hatch is provided for movement of large equipment.

All the power block structures are supported by a single common basemat. The basemat is considered to be an integral part of the containment boundary; it is constructed of reinforced concrete 9.7 feet thick.

The drywell is also a right circular cylinder located within and concentric to the containment. The inside diameter of the drywell is 69 feet and the wall is steel-lined reinforced concrete 5 feet thick. The drywell wall is rigidly attached to

the containment basemat and has a 6 foot thick annular concrete slab top. A removable head is bolted over an opening in the top slab for access to the reactor vessel for refueling operations. The lower portion of the drywell wall is submerged in the suppression pool. Three rows of 27.5 inch diameter vents, 34 vents per row, penetrate the drywell wall below the normal level of the suppression pool. Access to the drywell is via a double-door airlock, a double-gasketed, flanged and bolted dished equipment hatch, and the removable steel head previously discussed.

The suppression pool is supported by the containment basemat. The weir wall, located inside the drywell, forms the inner boundary of the suppression pool and is supported by the drywell sump floor. The weir wall is 1 foot, 10 inch thick reinforced concrete, steel clad on the suppression pool side. The inside diameter of the weir wall is 61 feet and the wall height is 23 feet, 9 inches above the basemat. The suppression pool is open to the atmosphere of containment and drywell, and contains approximately 146,000 ft³ of water.

The drywell sump floor is a donut shaped reinforced concrete slab, approximately 11 feet thick which rests on the basemat and supports the suppression pool weir wall and reactor pedestal. It is steel lined on the suppression pool side.

The drywell sump floor is bounded by the inner wall of the suppression pool with an outside diameter of 64 feet, 8 inches, and an inside diameter of 18 feet, 6 inches. The floor contains several drain sumps with a total volume of 720.5 ft³. The principal sump is the floor drain sump which has a volume of 569 ft³ and is connected to the Pedestal Cavity by a 6 inch diameter pipe.

The Pedestal Cavity (void area below the Reactor Pressure Vessel and inside the drywell floor) has a capacity of approximately

2400 ft³ from the cavity floor to the bottom of the opening for maintenance access.

The Reactor Pedestal supports the Reactor Pressure Vessel and Reactor Shield Wall. The pedestal consists of two concentric cylindrical steel shells connected by radial steel diaphragms. The annulus between the shells is filled with concrete. The top of the pedestal consists of a ring girder on which the Reactor Pressure Vessel rests. The vessel is bolted to the ring girder by 120, 3 inch diameter bolts. There are two openings through the pedestal shells for CRD piping, each measuring 44.3 ft², and located 12.8 feet above the drywell floor. There is also a maintenance access opening measuring 18.6 ft². The bottom of this opening is 9.1 feet above the pedestal cavity floor and 12 inches above the drywell floor (USAR, Figure 3.8-1).

4.1.2 Containment Systems

A description of the systems required to mitigate a severe accident are included in the front-end analysis section (Section 3.2) of this report. The majority of these systems are located external to the containment, and environmental extremes in containment and drywell during a severe accident will not impair the capability of these systems to perform their required safety function. The exceptions are:

- * Inboard containment isolation valves for various systems,
- * Automatic Depressurization System (ADS),
- * Combustible Gas Control System (CGCS),
- * Drywell and Containment Atmosphere, Mixing
- * Hydrogen Ignitors,
- * Suppression Pool,
- * Suppression Pool Makeup,
- * Containment Vent System, and
- * Containment/Drywell Ventilation Systems.

A detailed discussion of each of these systems with associated assumptions is presented in the following paragraphs.

4.1.2.1 Inboard Containment Isolation Valves

Included in this grouping are valves located on all lines which penetrate containment regardless of the safety importance of the system. All of these isolation valves are qualified for accidents under the provisions of 10CFR50.49, but are assumed to fail under the extremes of a severe accident such as postulated in this report. However, all of these valves either move to the required position early in an event or are already in the required position and are therefore assumed to successfully complete their required safety function. This assumption is valid for all events except Station Blackout (SBO).

Under an SBO condition, all valves are either in or fail to the required position or are an integral part of a closed-loop system with the exception of two valves (1FC007 and 1FC008). 1FC008 is the outboard isolation valve (located in the Fuel Building) for this containment penetration. It provides a flow path from the upper pool skimmers to the Fuel Pool Cooling and Cleanup Surge Tanks. Off-Normal Procedures address actions to check and, if necessary, manually close this valve.

For success, only 1 of the 2 (inboard/outboard) isolation valves must move to the required position.

4.1.2.2 Automatic Depressurization System (ADS)

Sixteen Safety-Relief Valves (SRVs) are mounted on the main steam lines between the Reactor Pressure Vessel (RPV) and the inboard Main Steam Isolation Valves (MSIVs). These SRVs are provided to prevent overpressurization of the RPV and, in the event of a need for makeup with concurrent loss of high pressure injection capability, to automatically depressurize the RPV to allow low

pressure systems to inject water into the vessel. The description of the ADS system and how it is modeled is in Section 3.2.1.8.

The discharge of all 16 SRVs is directed to the suppression pool through discharge quencher assemblies to condense steam and scrub radionuclides. The 9 ADS/LLS SRVs discharge into the suppression pool at locations as far as possible from ECCS pump suctions to prevent the pumps from pumping hot water and to provide thermal mixing of pool water. The SRVs are fully qualified for accident conditions, even though they would not be required to actuate following KPV breach. Figure 4.1-2 shows the SRV locations relative to the main steam lines and radial locations of the quenchers in the suppression pool. Figure 4.1-3 shows a typical SRV discharge quencher and the location relative to pool level and vent openings.

4.1.2.3 Combustible Gas Control System (CGCS)

The Combustible Gas Control System (CGCS) is designed to maintain the hydrogen concentration in the drywell and containment atmospheres below the combustible hydrogen level during post-LOCA conditions. The CGCS is in a standby condition during normal plant operation. The system consists of three sub-systems, including the following:

- * Drywell and Containment Atmosphere Mixing
- * Hydrogen Ignitors
- * Hydrogen Recombiners

The Hydrogen Recombiners are located outside the containment boundary but were not considered in the IPE because of their low capacity.

* Drywell and Containment Atmosphere Mixing

Two independent hydrogen mixing compressors, located in containment, take suction from high in the drywell, and discharge through 6 inch diameter piping to sparger assemblies located below the surface of the suppression pool. This serves to scrub radionuclides and condense steam before release to containment atmosphere. In order to relieve the pressure differential caused by removing air from the drywell, four parallel sets of two in series 10-inch diameter Vacuum Relief Valves begin opening at 0.2 psid and are fully open at 0.5 psid.

This open circulation system mixes the atmosphere in the drywell and containment and dilutes hydrogen concentrations. No credit was taken for the Drywell and Containment Atmosphere Mixing Compressors and Vacuum Relief Valves as a system capable of mitigating the severity of an accident because of the relatively low capacity of the system. Failure of two Vacuum Relief Valves in the same set would bypass the suppression pool and provide an unscrubbed release path to the containment atmosphere. This scenario was evaluated and determined to have a negligible probability. Therefore, it was not modeled in the Containment Event Trees (CETs). See Figure 4.1-4 Containment Combustible Gas Control Flowpath.

* Hydrogen Igniters

The Hydrogen Igniters are glow-plug type igniters designed to maintain post-LOCA hydrogen concentrations in the drywell and containment below 4% by a controlled burn of the hydrogen present in localized areas. The igniters are qualified for 330°F for 7 days and therefore are assumed to remain operable for their required mission time. The ignitor system is described in section 3.2.1.12.

Large quantities of hydrogen can be produced as a result of metal-water reaction in the Reactor Pressure Vessel during a degraded core event and from Core-Concrete Interaction (CCI) in the event the RPV is breached and corium material comes in contact with the Drywell Sump Floor or Reactor Vessel Pedestal Cavity. The hydrogen ignitors are designed to burn hydrogen at low concentrations, thereby maintaining the concentration below the detonable limit and preventing overpressurization that could occur as a result of a hydrogen detonation. CPS Emergency Operating Procedure EOP-7 requires the Hydrogen Ignitors to be turned off and/or not be energized if the hydrogen concentrations in containment/drywell are unknown or if the level exceeds the deflagration limits for a given containment pressure.

4.1.2.4 Suppression Pool

The Suppression Pool is an annular pool of demineralized water bounded on the outside by the containment wall and on the inside by the weir wall. It contains 146,000 ft³ of water, and the maximum design temperature is 185°F.

The Suppression Pool provides (a) a means to condense steam released in the drywell during a LOCA, (b) a heat sink for RCIC turbine exhaust steam, (c) a heat sink for SRV discharge to prevent containment temperature and pressure excursions, and (d) a source of water to Emergency Core Cooling Systems. The Suppression Pool is very effective in retaining fission products and condensible vapors from drywell venting and SRV discharges. The possibility of containment breach in the suppression pool area was modeled in the Containment Event Trees and truncated out for all events except for ATWS. It was calculated that 14% of containment failures from overpressure could be in the suppression pool area (section 4.4.9). This low value is partially because the liner of the suppression pool is made of stainless steel, which is more ductile than the carbon steel with which the remainder of containment is lined. Additionally, there

are fewer and less complex penetrations in the suppression pool. A breach in this area resulting in a significant loss of volume beyond the capability of Suppression Pool Makeup systems could result in unscrubbed release to the containment atmosphere as well as loss of core cooling/containment spray capability.

4.1.2.5 Suppression Pool Makeup

The normal suppression pool fill/makeup is via a 6 inch diameter line from the Cycled Condensate Storage Tank. This system is used to initially fill the suppression pool and make up for evaporative losses. The emergency suppression pool makeup is via a gravity dump of a portion of the Upper Containment Pool through two 24 inch diameter lines. The volume in the upper pool is sufficient to account for all conceivable post-accident entrapment volumes and still maintain long-term coverage of the drywell vents. Neither the CY system supply or gravity dump of the Upper Containment Pool were modeled because the suppression pool level is not expected to drop below that required to maintain NPSH to the ECCS pumps.

4.1.2.6 Containment Vent System

The purpose of emergency containment venting is to relieve containment pressure during accident conditions (1) when all other decay heat removal mechanisms combined are inadequate, (2) containment pressure is well beyond that calculated for any design basis accident, or (3) the structural capability of the containment is threatened, directly or indirectly. Additionally, containment venting is a means of removing hydrogen from the containment atmosphere.

CPS Containment Control Emergency Operating Procedure (CPS 4402.01) directs the operator to vent the containment via any vent path not necessary for core cooling before containment pressure reaches specified limits. If containment pressure

exceeds the specified value the operator is instructed to vent the containment by all pathways regardless of whether the system used for venting is needed for core cooling. Modeling of containment venting is discussed in section 3.2.1.11.

4.1.2.7 Containment/Drywell Ventilation

The Containment HVAC system (VR), Drywell Purge system (VQ), and Drywell Cooling System (VP) are not required or designed to function under Design Basis Accident conditions with the exception of their containment isolation valves. These systems have limited capacity and may not be available under Post-Accident conditions and therefore were not modeled.

4.1.3 Systems Credited After Containment Failure

The Core Spray and RHR systems were credited with continued operability following containment failure under all circumstances with the exception of loss of Suppression Pool level due to a breach of containment in the Suppression Pool. A breach into one of the adjacent ECCS pump rooms is assumed to flood the compartment and thus render the flooded train inoperable. Since each ECCS room is separate and water-tight, the Suppression Pool water loss from uncontrolled flooding within any individual ECCS pump room is limited, and redundant equipment in adjacent rooms is protected from flooding. Flooding of the drywell inside the weir wall in conjunction with flooding of the largest ECCS pump room will result in Suppression Pool level dropping below the minimum drywell vent coverage level, but will not result in loss of suction for other ECCS pumps. A breach of containment in the Suppression Pool at a location other than an ECCS pump room (e.g. into Fuel Building) could result in complete loss of Suppression Pool level. However, breach of the Suppression Pool into the Fuel Building is unlikely because there are fewer liner strain discontinuities in this area.

Other equipment of the Core Spray and RHR systems are either in their required positions, or move to their required positions shortly after containment failure. It is assumed any harsh environmental conditions would not degrade these components during the short time between containment failure and component actuation.

The suction and injection lines for these systems are expected to remain intact. Continued operation is assured with an assumed 50% suction strainer plugging (USAR section 6.2).

Table 4.1-1

Principal Dimensions and Parameters

	CPS	GG NUREG 1.50
<u>Containment</u>		
* Height above basemat (ft)	215	206.75
* Inside diameter (ft)	124	124
* Wall thickness (ft)	3	3.5
* Dome thickness (ft)	2.5	2.5
* Total free air volume (ft ³)	1.55E+6	1.4E+6
* Design pressure - internal (psig)	15	15
* Design pressure - external (psig)	3	3
* Cont volume/thermal power rating (ft ³ /kw)	.62	.36
* DBA peak response (psig)	3.7	---
* Maximum leakage (% vol/day)	.65	.437
* Internal Design Temperature (°F)	185	185
<u>Drywell</u>		
* Inside diameter (ft)	69	73
* Wall thickness (ft)	5	5
* Top slab thickness (ft)	6	6
* Design Pressure - Internal (psig)	30	30
* Design Pressure - External (psig)	17	17
* Design differential pressure (psid)	30	21
* Total free air volume (ft ³)	2.46E+5	2.7E+5
* Internal Design Temperature (°F)	330	330
* DBA Peak Response (psig)	18.9	---
<u>Suppression Pool</u>		
* Design Pressure (psig)	15	15
* Internal Design Temperature (°F)	185	185
* Water Volume (ft ³)	1.46E+5	1.36E+5
* Cont. Pool Volume/Thermal power rating (ft ³ /kw)	0.0504	0.035

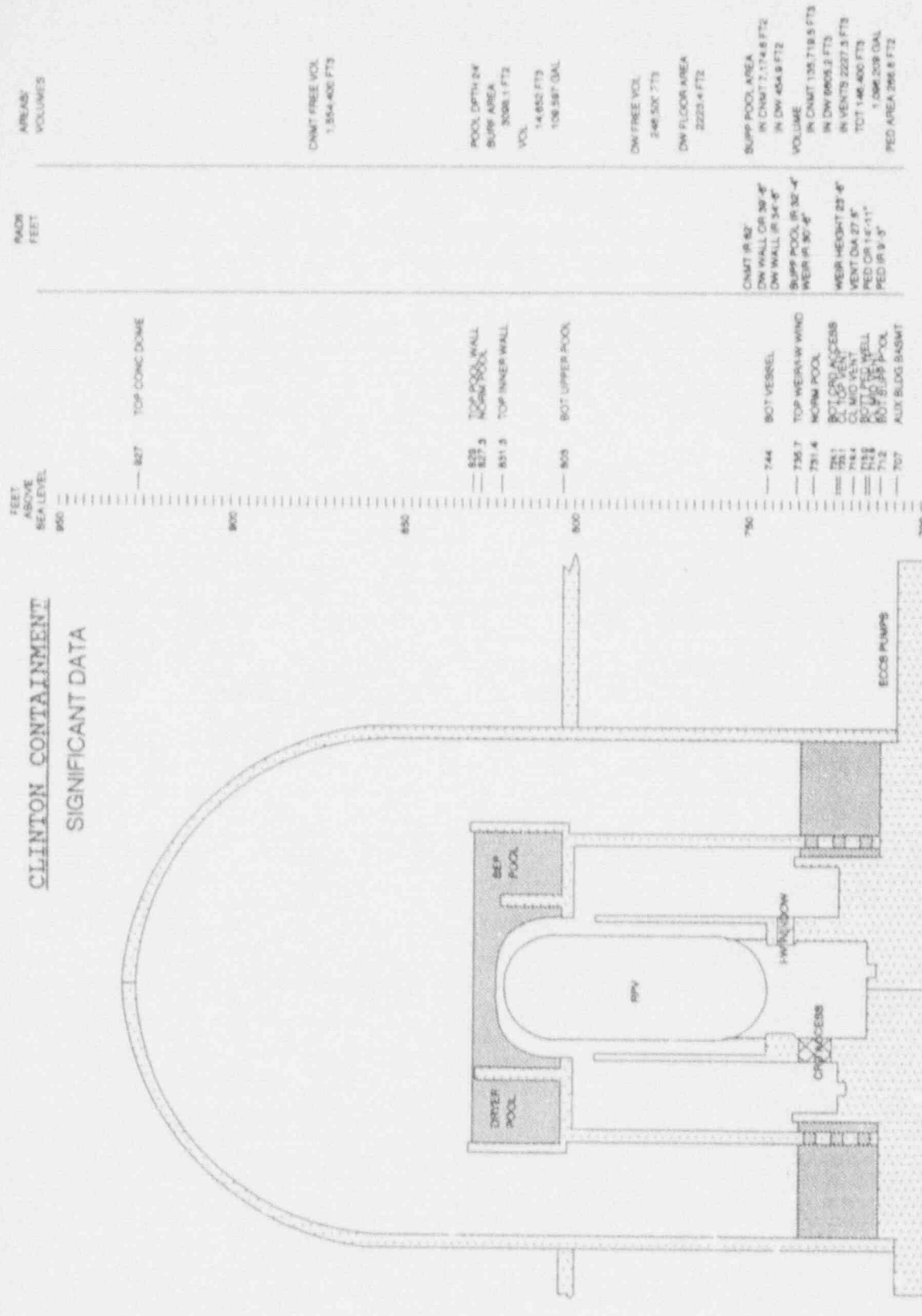

CLINTON CONTAINMENT
SIGNIFICANT DATA

FEET ABOVE SEA LEVEL	MARK FEET	AREAS/ VOLUMES
827		DNMT FREE VOL 1,354,400 FT ³
827.3		POOL DEPTH 24" SUPP AREA 3081.1 FT ² VOL 14,652 FT ³ 108,587 GAL
831.3		POOL DEPTH 24" SUPP AREA 3081.1 FT ² VOL 14,652 FT ³ 108,587 GAL
803		DNMT FREE VOL 248,527 FT ³ DNV FLOOR AREA 2223.4 FT ²
744		SUPP POOL AREA IN DNMT 1,174.8 FT ² IN DNV 404.8 FT ² VOLUME IN DNMT 135,718.5 FT ³ IN DNV 8605.3 FT ³ IN VENTS 2227.3 FT ³ TCT 146,400 FT ³ 1,086,209 GAL PED AREA 296.8 FT ²
736.7		DN WALL CR 30'-4" DN WALL IR 34'-4" SUPP POOL IR 32'-4" WEIR IR 30'-4"
731.4		DNMT IR 32' DN WALL CR 30'-4" DN WALL IR 34'-4" SUPP POOL IR 32'-4" WEIR IR 30'-4"
721		DNMT IR 32' DN WALL CR 30'-4" DN WALL IR 34'-4" SUPP POOL IR 32'-4" WEIR IR 30'-4"
718		DNMT IR 32' DN WALL CR 30'-4" DN WALL IR 34'-4" SUPP POOL IR 32'-4" WEIR IR 30'-4"
712		DNMT IR 32' DN WALL CR 30'-4" DN WALL IR 34'-4" SUPP POOL IR 32'-4" WEIR IR 30'-4"
707		DNMT IR 32' DN WALL CR 30'-4" DN WALL IR 34'-4" SUPP POOL IR 32'-4" WEIR IR 30'-4"

827 TOP CONC DOME

827.3 TOP POOL WALL

831.3 TOP INNER WALL

803 BOT UPPER POOL

744 BOT VESSEL

736.7 TOP WEIR/WIND

731.4 NORM POOL

721 BOT CR/ACCESS

718 CL. MOUNT

712 SCUT. P. WELL

707 BOT SUPP P-VOL

AUX BLDG BASMT

ECCS PUMPS

MOI-1101, Srs 4, Rev B 527-1901, Rev R 527-1964, Rev N USAR 4.2

MOI-1111, Srs 4, Rev D 527-1902, Rev T 527-1965, Rev Y

MOI-1112, Srs 4, Rev D 527-1428, Rev T USAR Fg 3.9-2

MOI-1113, Srs 2, Rev C 527-1833, Rev AW 581, Cal. 3C10-1963-002 Rev 6

Figure 4.1-1

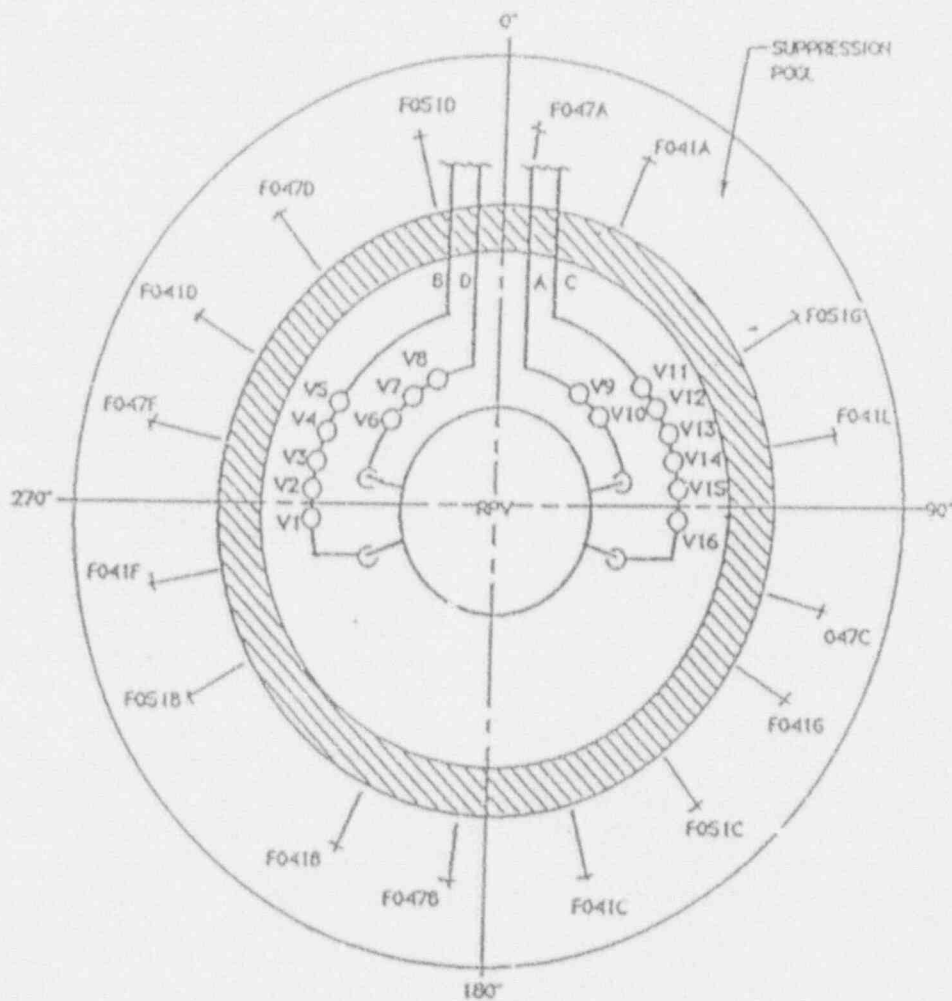

NOXEMCLATURE

V1 - F047B	V5 - F047E	V9 - F047A	V13 - F047C
V2 - F041B	V6 - F041D	V10 - F041A	V14 - F041G
V3 - F051B	V7 - F047D	V11 - F051G	V15 - F051C
V4 - F041F	V8 - F051D	V12 - F041L	V16 - F041C

Figure 4.1-2

SRV Discharge Locations

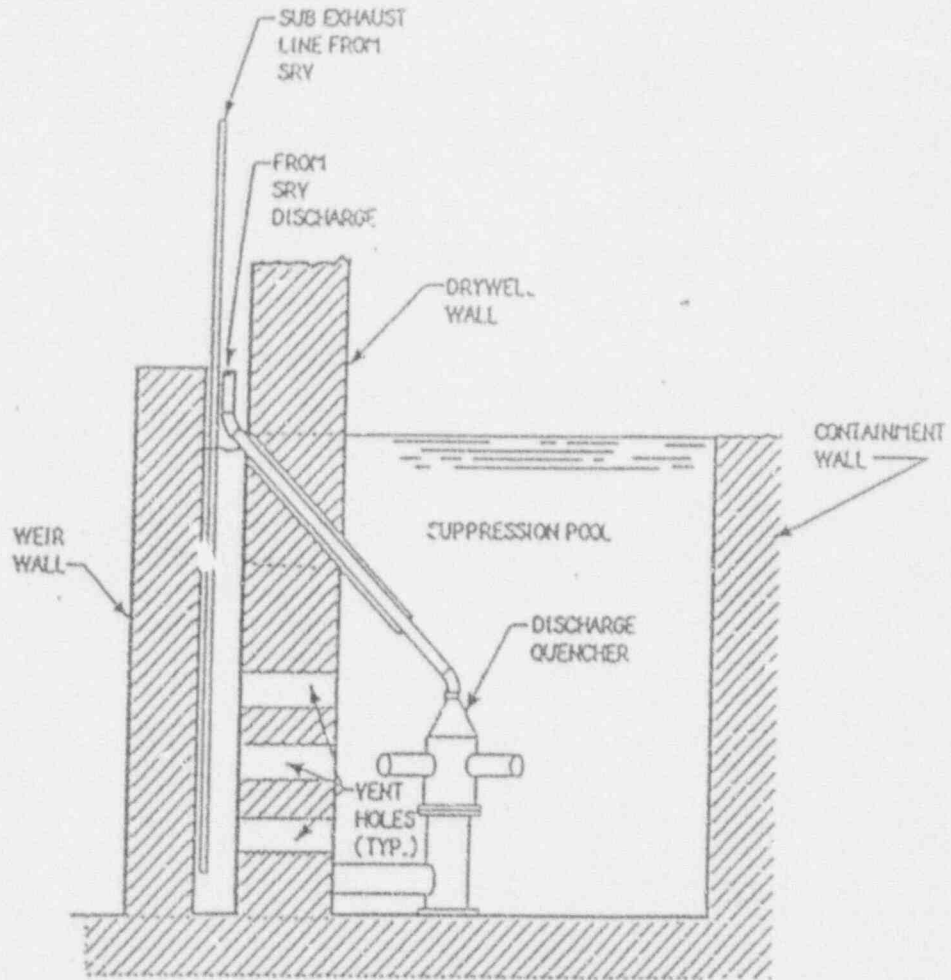

Figure 4.1-3

Typical SRV Quencher

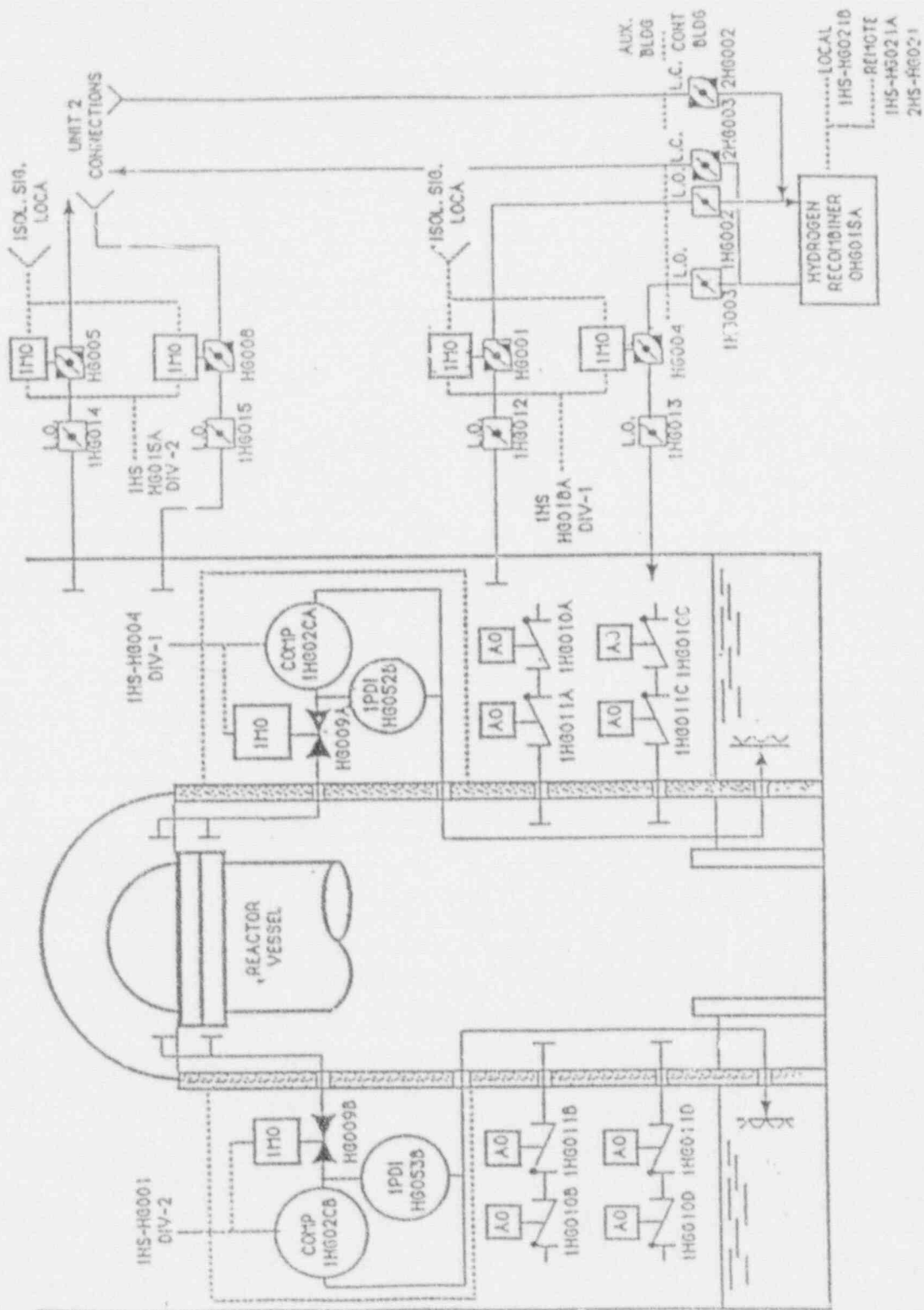

Figure 4.1-4
Containment Combustible Gas Control Flowpath

4.2 Plant Models and Methods for Physical Processes

This section documents the analytical models used in the accident progression analysis. General assumptions used in the modeling of phenomenology are also described.

4.2.1 Plant Models

The Modular Accident Analysis Program (MAAP) was the primary code used for the containment performance analysis. CPS specific data, including Containment, Drywell and Suppression Pool parameters, were used as input to the MAAP parameter file to provide the most accurate output achievable. The Computer Aided Fault Tree Analysis (CAFTA) and Set Equation Transformation System (SETS) were used for the containment systems and event tree sequence quantification.

4.2.2 General Assumptions

Important assumptions used in the level 2 analysis in addition to those listed in section 3.1.2.3 are listed below.

1. Medium/large LOCAs and IORVs are assumed to depressurize the vessel without additional operator action.
2. For ATWS sequences, the Containment is assumed to fail prior to vessel failure or core damage, given unsuccessful SLC injection.
3. Suppression Pool bypass by loss of suppression pool inventory is modeled in the CETS. The radionuclide scrubbing capability of containment spray is not modeled upon loss of suppression pool inventory because the sprays are inoperable without suppression pool inventory. However the sprays may be available early in an event.

4. The Late Injection heading on CET's is applicable to cooling core debris after vessel failure.
5. A release of radionuclides is modeled as a certainty if containment isolation fails following core damage. The release will occur regardless of the operation of core cooling systems or the availability of containment systems, however the systems can affect the magnitude of the release.
6. Motor operators for containment inboard isolation valves are assumed to fail under the extreme environmental conditions postulated during a severe accident. However all of these valves are either in the required position or move to the required position early in an event, and are assumed to complete the required function before degradation occurs. This assumption is valid for all events except Station Blackout (SBO). See section 4.1.2.1 for the discussion of isolation in a SBO.
7. The Hydrogen Igniters were assumed to maintain hydrogen concentrations below the detonable limit if all igniters in one division fail, and less than 6 igniters in the redundant division fail. This assumption is based on the results of the NSAC 106 study at the 1/4 scale test facility for hydrogen ignitions with additional conservatisms for Perry versus CPS configuration.

8. Potential for containment failure in the Suppression Pool area was modeled in the CET's.
9. Only three of the available six containment venting pathways are modeled. All RHR, FC and VR system components that must reposition to initiate venting via the modeled pathways are also modeled. Pipe rupture in these systems is not modeled as this failure would not prevent venting of the containment.
10. Failure of drywell and containment penetrations due to reaction forces on the RPV during high pressure blowdown is not a significant threat to containment integrity at CPS. Calculations show that under the worst case blowdown scenario, the thrust and lift force are less than 10% of the reactor vessel hold-down bolt and weight forces (section 4.4.2).
11. Direct Containment Heating (DCH) is not regarded as a significant challenge to containment integrity for CPS plant. Calculations show that for core melt and vessel failure, this phenomenon will not lead to suppression pool saturation and will cause only a few psi increase in containment pressure. Containment pressurization due to DCH is not included in the Containment Event Trees (section 4.4.6).

12. Steam explosions were evaluated for both In-vessel and Ex-vessel events as potential mechanisms for containment failure. Neither of these sequences provide sufficient energy to breach containment, therefore the CETs for CPS do not include a node for in-vessel or ex-vessel steam explosions (section 4.4.3).
13. All Direct Containment Bypass (ISLOCA) sequences vanished in truncation in the level 1 analysis (section 3.4.1.1 and figures 3.1-12).
14. Containment Penetration failure because of thermal attack is not expected at CPS. Therefore containment penetration failure from high temperature is not included in the CETs (section 4.4.4).
15. Containment failure from a Molten Core-Concrete Interaction (MCCI) has been shown not to be a likely failure mode. In the event the core is ejected into the Reactor Vessel cavity and is not coolable, the containment would have failed by other means before basemat penetration occurs. Therefore, MCCI was not nodalized in the CPS CET's (section 4.4.7).
16. Hydrogen detonation and subsequent containment failure are of concern only during a long term SBO. A node for hydrogen control has been included in the CPS CET's (section 4.4.8).
17. The most probable containment failure location from overpressure is a tear in the liner above the suppression pool at a penetration. The pressure at which the containment has a 50% probability of failure was calculated to be approximately 93.8 psig (section 4.4.9).

4.3 Bins and Plant Damage States

This section covers the methodology and results of binning sequences from the front end analysis (level 1) for evaluation in the back end analysis (level 2) and binning of the results from the back end sequence quantification. The bins are organized by factors such as timing, reactor condition and containment conditions. A discussion of the binning process is presented for the following level 1 and level 2 results:

- Accident Classes
- Containment Failure Modes
- Release Modes

4.3.1 Methodology

The level 2 analysis follows the EPRI simplified methodology discussed in RP 3114-29, "Generic Framework for Individual Plant Examination (IPE) Back-end (Level 2) Analysis". Containment event trees were constructed emphasizing things the operator could see and control, such as containment pressure and temperature, system operation, etc.

A CET was developed for each accident class described in section 3.1.5. The sequence equations from the level 1 analysis for each accident class were used as input for each CET.

The CET sequences are built based on success or failure of the headings identified as listed above. The mission time used for the level 2 analysis was 48 hours, based on the high likelihood of repair and external resources in that time period.

Each sequence in the CETs was quantified. Those that survived truncation at $1E-9$ were all classified for plant damage state, release mode, and source term, as discussed in sections 4.3.3, 4.3.4, and 4.3.5.

4.3.2 Front-to-Back End Interfaces

Five major classes of accidents were used to categorize the level 1 accident sequence results. These categories were further subdivided into subclasses. The accident classes were previously discussed in paragraph 3.1.5. Those which had cutsets from the level 1 analysis are presented in Table 4.3-1. The predominant accident class and subclasses are dependent on failures identified in the level 1 sequences that are assumed to lead to core damage. These accident classes are convenient for characterizing the level 1 results and identifying plant design and operating characteristics that drive the potential for core damage.

The accident classes are also useful for transferring the results of the level 1 PRA into the level 2 Containment Event Trees (CET). This transfer is accomplished by simply using the equations from the level 1 sequences by accident class as inputs for each CET. Fault tree linking allows dependencies and failures important to the level 1 results to be carried directly into the level 2 sequence analysis. Fault trees developed for the level 2 event tree headings which are similar to level 1 fault trees, allow for these dependencies to be represented in the level 2 sequence analysis. The level 2 analysis contains additional sequence and timing dependencies. Some systems that may not have been modeled in level 1 sequences were modeled in the level 2 analysis. For example, low pressure injection systems are of no help in preventing core damage if the vessel cannot be depressurized, but may be useful for debris cooling after vessel failure. Similarly, if a system had failed and could not be recovered in time to prevent core damage, additional time is available for recovery in order to prevent containment failure. This additional conditional recovery is applied to the appropriate failure events in the sequences. Table 4.3-2 is provided to summarize these types of modeling dependencies.

4.3.3 Plant Damage States

Plant Damage States (PDS) are identified for each sequence of the level 2 CET's which was not eliminated from consideration by truncation. A four letter code (A BB C) was used to identify the Plant Damage State (CET end state). These codes are identified in Table 4.3-3.

The first letter (A) defines the state of the reactor at the time of vessel penetration, whether the event was recovered within the vessel or vessel penetration was assumed to occur at either high or low pressure.

The second two letters (BB) are used to define the state of the containment at the end of each of the containment event tree sequences. Whether the containment is intact or failed as a result of various severe accident phenomena is identified. The containment failure modes identified by this two letter code are patterned after the phenomenological challenges identified in NUREG-2300, "PRA Procedures Guide". In this manner, the CET sequences are categorized into functional causes for containment failure much in the way the level 1 sequences were classified with respect to functional challenges to core cooling.

The last letter (C) in the plant damage state identifier represents the timing of the event. It should be noted that the timing specified in this identifier is relative to the onset of core damage.

4.3.4 Release Mode

The release mode describes the type of releases for source term binning, and is shown for each sequence on the CET that was not eliminated by truncation. The release mode codes are alphanumeric (eg. D5). The alphabetical designators are used to describe the containment status as follows.

1. A - Containment or reactor vessel is intact at accident termination.
2. B - Containment failure occurs with release scrubbed through the suppression pool.
3. C - Containment failure precedes or is concurrent with reactor vessel failure. The suppression pool is bypassed.
4. D - Containment failure is delayed after reactor vessel failure. The suppression pool is bypassed.
5. E - Radionuclides exit the reactor directly to atmosphere through an unisolated LOCA outside containment.

Subcategories of the release modes are identified by numeric designators 0-12. Generally speaking, odd numbers indicate a small containment failure and even numbers indicate a large containment failure.

Table 4.3-4 shows the relationship between the various conditions of the containment and release locations. Figure 4.3-1 is an example of a CET showing the Release Mode and the logic and assumptions used.

4.3.5 Assessment of Source Term Importance

Determination of the actual source term resulting from the level 2 sequences is based on the relative amounts of various types of fission products released from containment. Fission products are categorized into the following three groups:

- Noble Gases - This group includes inert gases. A large fraction of this group is released during any containment failure scenario. From a hazard standpoint, they are relatively unimportant because of their chemically inert nature.
- Volatiles - This group is composed of CsI, RbI, TeO₂, CsOH and Te₂. This group represents the greatest hazard because it contains the important Cesium, Iodine and Tellurium isotopes.
- Non-Volatiles - This group is composed of SrO, MoO₂, BaO, lanthanides, CeO₂, Sb and Uranium/transuranics. There is not ordinarily any large amount of these fission products released.

The amount of these fission products released from containment in the level 2 sequences is calculated by the MAAP code.

Using the release percentages of the different fission product categories, a release category is determined for each level 2 sequence. Table 4.3-5 presents the guidelines for determining the sequence release category.

Table 4.3-1

Front-to-Back End Interface

<u>Containment Event Tree</u>	<u>Input</u>
IA	Class IA - Containment intact at core melt, RPV at high pressure.
IB	Class IB - Containment intact at core melt, Station Blackout
ID	Class ID - Containment intact at core melt, RPV at low pressure.
IIIB	Class IIIB - Small/medium LOCA, No depressurization of RPV.
IIIC	Class IIIC - Medium/large LOCA, RPV at low pressure.
IV	Class IV - ATWS
-	Class V - ISLOCA, occurring outside containment. No CET was developed for ISLOCA because all of these sequences truncated out in the level 1 analysis.

Level 1 to Level 2 System Dependencies

ACCI DENT CLASS	DEPRESS	* * * * DEBRIS COOLING * * * *							
	ADS	HPCS	RCIC	FW	LPCS	LPCI	CD/CB	CRD	FP
IA	1	1	4	1	6	6	6	9	11
IB	10	2	4	2	7	7	7	10	11
ID	NR	1	4	1	1	1	1	9	9
IIIB	1	1	4	5	6	6	6	9	11
IIIC	NR	1	4	1	1	1	1	9	9
IV	1	3	4	1	3	3	6	8	6

KEY:

- 1 FAILED IN LEVEL 1 (RECOVERABLE)
- 2 FAILED (RECOVERABLE) OR NO POWER (RECOVERABLE)
- 3 SUPPRESSION POOL SUCTION SOURCE UNAVAILABLE
- 4 NOT CREDITED (HIGH STEAM LINE RADIATION)
- 5 INADEQUATE AT LEVEL 1, CREDITED IN LEVEL 2
- 6 AVAILABLE AFTER DEPRESSURIZATION OR VESSEL FAILURE
- 7 NO POWER AT LEVEL 1, AVAILABLE AFTER POWER RECOVERY AND DEPRESSURIZATION OR VESSEL FAILURE
- 8 NOT CREDITED IN LEVEL 1, AVAILABLE IN LEVEL 2
- 9 INADEQUATE ALONE, USED FOR DELAYED FAILURE RECOVERY IN LEVEL 1, ALLOWED FOR LEVEL 2
- 10 NO POWER AT LEVEL 1, AVAILABLE AFTER POWER RECOVERY
- 11 INADEQUATE ALONG, USED FOR DELAYED FAILURE RECOVERY IN LEVEL 1, AVAILABLE AFTER DEPRESSURIZATION OR VESSEL FAILURE
- NR NOT REQUIRED

Table 4.3-2

Plant Damage State Codes

A is the reactor status, either:

- R - Recover in vessel
- L - Vessel penetration at low RPV pressure
- H - Vessel penetration at high RPV pressure

BB is the containment status:

- XX - Containment intact
- VS - Vent through suppression pool
- VB - Vent bypassing suppression pool
- OD - Overpressure failure due to decay heat
- OA - Overpressure failure due to ATWS
- OH - Overpressure failure due to hydrogen combustion
- OV - Overpressure failure due to loss of vapor suppression
- CI - Containment isolation failure
- CB - Isolation failure with suppression pool bypass

C is the timing of the event:

- X - Not applicable
- E - Early (< 6 hours)
- I - Intermediate (6 to 24 hours)
- L - Late (> 24 hours)

CODE = **A BB C**

Table 4.3-3

RELEASE MODES

CONTAINMENT STATUS		RELEASE LOCATION FROM VESSEL	SMALL CONTAINMENT FAILURE		LARGE CONTAINMENT FAILURE	
			BEFORE VESSEL FAILURE	DELAYED AFTER VESSEL FAILURE	BEFORE VESSEL FAILURE	DELAYED AFTER VESSEL FAILURE
INTACT	ISOLATED		A0			
	VENTED		A1		A2	
FAILED	THRU SP		B1		B2	
FAILED BYPASSING SUPPRESSION POOL	WITH SPRAY	WETWELL	C1	D1	C2	D2
		DRYWELL	C3		C4	
	WITH INJECTION	WETWELL	C5	D3	C6	D4
		DRYWELL	C7		C8	
	NO INJECTION	WETWELL	C9	D5	C10	D6
		DRYWELL	C11		C12	
CONT BYPASS			E1		E2	

Table 4.3

Table 4.3-5

Level 2 Release Categories

<u>Category</u>	<u>Noble Gases</u>	<u>Volatiles</u>	<u>Non-Volatiles</u>
NR	0	0	0
I	$\leq 100\%$	$\leq 1\%$	$\leq 0.1\%$
II	$\leq 100\%$	1-10%	0.1-1.0%
III	$\leq 100\%$	$> 10\%$	$> 1.0\%$

Utilizing this categorization scheme, a release category was assigned to each level 2 sequence that was not truncated out. Table 4.7-1 displays the source term information for all evaluated sequences.

It also includes the Plant Damage State, Release Mode, vessel failure time, and containment failure time. Event timing was calculated to within a few minutes.

Release Mode Example

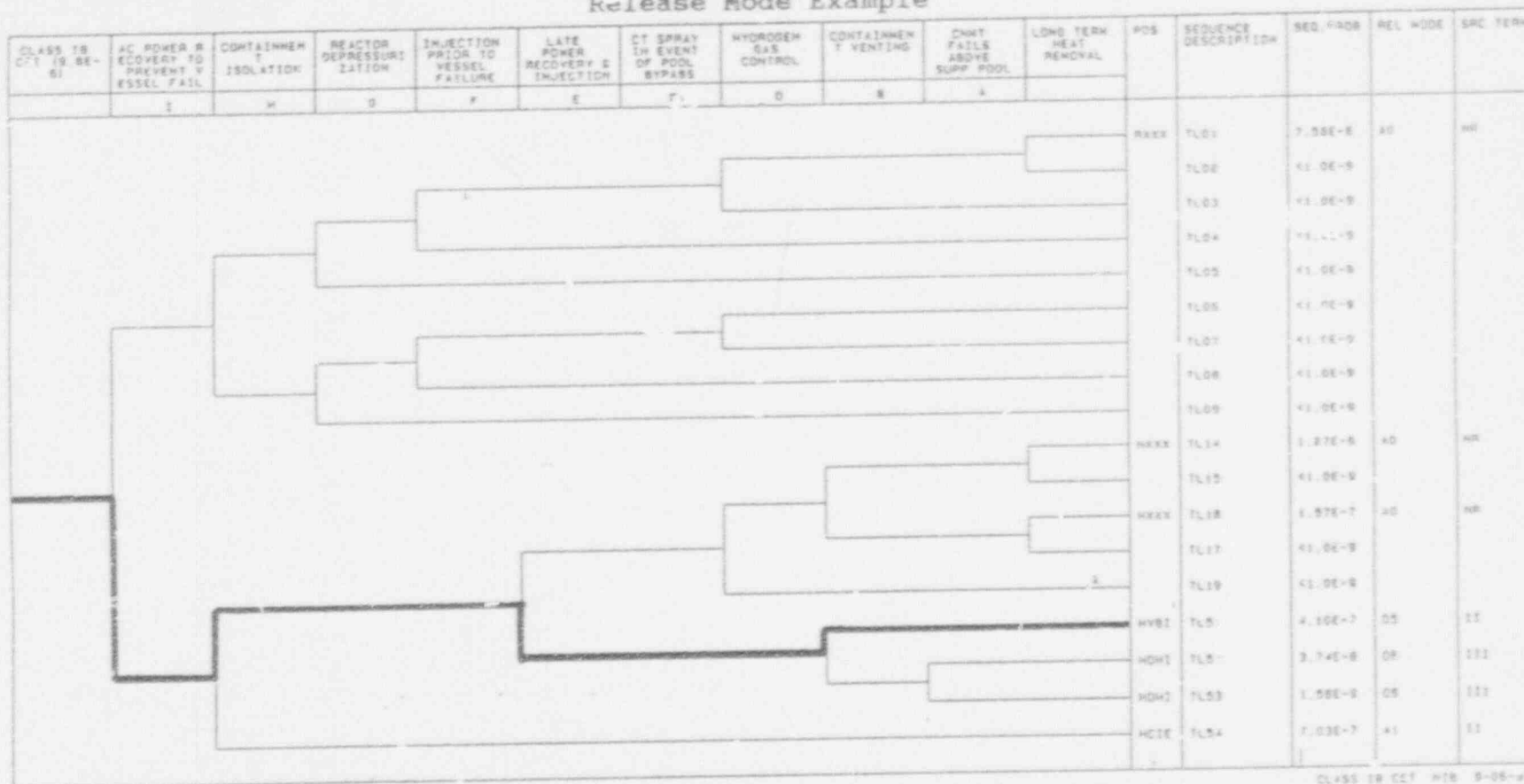

CLASS IS CCI H10 9-06-82

Description - AC power recovery in time to prevent vessel failure unsuccessful, containment isolation successful, no RPV depressurization, late power recovery & injection unsuccessful, containment venting available if required.

Results - RPV failure occurred at 2.7 hours, peak drywell temperature reached 1309F with the onset of drywell penetration seal failure from thermal attack occurring at 11.4 hours, containment venting began at 13 hours using a 4 inch vent path, peak containment pressure reached 22.4 psig.

Plant Damage State - HXBI

Release Mode - 05 (modeled as a containment failure instead of venting since suppression pool bypass occurs)

Figure 4.3-1

4.4 Containment Failure Characterization

This section presents discussions of the various potential containment failure mechanisms and summaries of the evaluations which were performed to determine the applicability of the phenomena to the CPS Mark III containment.

4.4.1 Direct Containment Bypass

Direct Containment Bypass refers to accident sequences that involve releases of fission products from the primary system directly to the outside of the Containment. Such scenarios require the occurrence of an opening in the primary system pressure boundary outside of the Containment that creates an unisolated flow path. Typical initiating events for such sequences include steam line breaks outside of Containment that are coincident with failure of the Main Steam Isolation Valves (MSIV) and low pressure system piping failures induced by inadvertent exposure to full primary system pressure, e.g., Interfacing System Loss of Cooling Accidents, ISLOCA. Subsequent system failures are required that prevent coolant make-up to the reactor vessel. Regardless of the hypothesized sequence of events, however, the common feature of all of these scenarios is that the substantial fission product retention capabilities of the Containment are ineffective.

The screening criterion for Direct Containment Bypass sequences (Class V) is $1.0E-7$ per year of reactor operation. For CPS, all Class V (ISLOCA) sequences truncated out in the level 1 analysis at $1.1E-9$. The break locations considered were for all piping external to containment that tie in directly to the Reactor Pressure Vessel or Recirculation System piping, including Main Steam and Feedwater piping in the steam tunnel (section 3.1.J.5.2)

4.4.2 Vessel blowdown

Vessel Blowdown is the high pressure ejection of the reactor vessel contents, including molten core debris from a failed reactor vessel. The concern is that jet thrust forces would be large enough to cause vessel movement on its foundation and tear drywell and containment penetrations. An analysis was performed to assess whether the CPS RPV and supporting structures could withstand the upper bound thrust that would be expected at the time of vessel breach.

The forces from the upper bound combination of jet thrust from the vessel penetration and lift forces from differential pressure between the pedestal area and the drywell were calculated to be 577,500 lb_f assuming a 2 psi differential between the pedestal area and drywell. MAAP analysis supports the 2 psid value. The forces opposing the blowdown force are the weight of the vessel and internals, and the tensile strength of the 120 vessel holddown bolts. The holddown bolts force was calculated to be 102.6 million lb_f and the vessel/internals were estimated to weigh 1 million pounds. Thus the forces opposing vessel movement are approximately 180 times the force that could cause vessel movement. A similar calculation was performed using 200 psid between the pedestal area and the drywell. Even using this extreme value, the holddown forces greatly exceed the forces that could cause vessel movement.

Based on the preceding discussion and previous calculations, this issue does not represent a credible challenge to the containment integrity at CPS. The maximum amount of force that could be produced from vessel blowdown with uncertainties considered has been shown to be considerably less than the vessel holddown force from the bolts alone.

4.4.3 Steam Explosions

Steam explosion events were evaluated for both in-vessel and ex-vessel as potential mechanisms for containment failure under severe accident conditions and, therefore, as potential causes for radioactive releases to the environment.

4.4.3.1 In-vessel

The issue for in-vessel steam explosions is whether an explosion of sufficient magnitude to fail the reactor vessel, with consequential failure of the containment, could occur. This was addressed by evaluating the fundamental physical processes required to create an explosion that could result in vessel failure. The analysis closely follows the IDCOR assessment of this phenomenon and indicates that explosions of this magnitude are not likely to occur within the CPS reactor vessel. This is in agreement with the findings of the NRC sponsored Steam Explosion Review Group (SERG) which concluded that the likelihood of an in-vessel steam explosion leading to alpha mode containment failure, was very unlikely.

Experimental evidence has demonstrated that a relatively high reactor coolant system pressure prevents explosions altogether. For conditions in which reactor pressure exceeds 150 psia, steam explosions are not considered possible.

For events in which reactor pressure is likely to be low, a number of conditions must be met in order to produce an energetic fuel-coolant interaction that might jeopardize the integrity of the reactor vessel:

- Large amount of core debris entering the lower plenum at once.
- Fragmentation of the hot material within the water in the lower plenum.
- A trigger to initiate the explosion.
- Efficient energy transfer from the debris to the coolant.
- An overlying slug of water to transmit energy in a coherent fashion.
- The ability of the slug to be transmitted through the upper structures within the reactor pressure vessel.

All of these factors must have the right parameters to create an event with enough magnitude to rupture a reactor pressure vessel. The failure of any of them to achieve the proper conditions precludes the possibility of generating a missile that could presumably impact the containment boundary and thus induce an alpha-mode containment failure. At CPS, because of the lower core plate design, a large amount of core debris entering the lower plenum at one time is unlikely. The internal core configuration, steam separators and dryers greatly reduce the probability of a water slug reaching the vessel head with sufficient energy to displace it.

As a result, conditions which could lead to vessel rupture due to an in-vessel steam explosion are not expected for CPS. In addition, the drywell head that is located above the RPV has a pool of water above it. These are barriers that would be in the path of a missile before the containment boundary is approached. In view of the Mark III design, the alpha mode failure mechanism is not a credible containment failure mechanism. Consequently,

on the basis of design and the preceding discussion, no node was included for in-vessel steam explosions in the CPS containment event trees.

4.4.3.2 Ex-vessel

Ex-vessel steam explosions are theoretically possible and may be an important mechanism for the quenching of core debris discharged from the reactor vessel. There are two aspects to be addressed: (1) potential overpressure in the containment due to rapid steam generation and (2) shock waves which could be created by the interactions.

1. Containment Overpressure

Containment overpressurization may occur as a result of rapid and extensive steam generation because of molten metal deposition into a pool of water. For CPS, the following assumptions were used to calculate the pressure increase in drywell and containment.

- molten material = $\frac{1}{4}$ the core; $\frac{1}{4}$ the lower core plate; $\frac{1}{4}$ of CRD Mechanisms; $\frac{1}{4}$ the lower vessel head
- Water = Vessel pedestal full of water up the lower edge of CRD cart opening.

Drywell pressure increase, given the above conservative assumptions, is 1.036 psi. This value is well below the design pressure of the drywell. Containment pressure increase was calculated by adding containment volume to the drywell/pedestal volumes. The containment pressure increase is 0.15 psi. This value is well below the design pressure of 15 psig, and is insignificant when compared to the containment expected failure pressure of 93.8 psig.

2. Shock Waves

Drywell failure could be postulated to occur as a result of shock waves generated during an ex-vessel steam explosion. The same assumptions given above for containment overpressurization were used. Additionally, it was conservatively assumed that (1) a peak pressure of 1450 psi occurs in the interaction zone (2) vessel failure occurs within 5 ft of vessel vertical centerline and radially in line with the pedestal opening to the drywell and (3) shock wave originates at the pedestal floor elevation. The distance to the drywell wall is 32 feet, and calculations show the maximum peak instantaneous pressure rise at the drywell wall, at a location above the weir wall, is 3.6 psid, well below the design pressure. A similar calculation for shock wave pressure on the pedestal yielded a maximum peak instantaneous pressure on the pedestal wall of 43.4 psi. This pressure is not expected to cause damage to the pedestal, the vessel lower head, or the vessel skirt. Pressure attenuation over distance was considered in the calculation, however obstacles in the path of the pressure wave which could also attenuate the pressure were not considered.

The two preceding paragraphs provide conservative estimates for the two pressurization mechanisms associated with potential ex-vessel steam explosions. The 1.036 psi increase due to pressurization and 3.6 psi pressure from shock waves, yields approximately 4.6 psid at the drywell wall which has a design pressure of 30 psid. This value is not detrimental to the integrity of the drywell and therefore the CETs for CPS do not include a node for ex-vessel steam explosion.

4.4.4 Penetration Thermal Attack

Drywell and containment electrical and mechanical penetrations may be exposed to high temperature following reactor vessel breach during a severe accident. Atmospheric heating of the drywell by molten core debris and the resulting high drywell gas temperature could affect the sealing capabilities of elastomers used in various drywell penetrations. This could result in eventual degradation of containment penetrations, ultimately allowing a release path to secondary containment. The degree and timing of this postulated failure mode is dependent on (1) the gas temperature achieved, (2) the duration, or exposure time at elevated temperature, and (3) the characteristics of the elastomeric materials involved.

Drywell and containment penetrations have pathways that allow the atmosphere to come into direct contact with penetration inboard non-metallic seal materials. Heat transfer to the inboard seal material would be by convection as the high temperature gas comes in contact with exposed seal materials.

Heat transfer to the penetration outboard seal materials would be almost exclusively by conduction through the metallic parts of the penetration. The overall convective contribution to penetration outboard seal material is expected to remain small, even after significant degradation of penetration inboard seal material.

Table 4.4-1 lists the various non-metallic materials in CPS drywell and containment penetrations, the tested temperature for each material, the expected temperature during severe accident conditions, and the anticipated life of the materials at the expected temperature as calculated by the Arrhenius equation.

The life expectancy for the drywell materials at 700°F exceeds two weeks. This is much longer than expected for a recovery of core cooling.

The maximum containment temperature seen in the MAAP runs was less than the tested temperatures for all but one sealing material, (Bisco LOCASEAL). This material (LOCASEAL) was actually tested to 355°F for short periods of time. It is the pressure retaining part of the containment electrical penetrations and failure in itself would not cause a leak out of the containment. Its life expectancy in the containment environment is 504 days.

Failure of the containment because of penetration seal failures due to elevated temperatures is not expected at CPS.

Based upon experimental data and CPS MAAP runs, under worst case conditions, drywell temperature is expected to exceed 700°F about 11 hours into an SBO with no operator actions. Drywell non-metallic seal degradation will not result in a significant increase in drywell leakage prior to 700°F.

It is concluded that a release from the reactor to the drywell can propagate to the containment via drywell penetration failures after drywell temperature reaches 700°F. This release would bypass the suppression pool but would be retained within the containment since no containment penetration failure is expected because of elevated temperatures. Because of this penetration failure, the drywell and suppression pool were assumed bypassed for sequences in which drywell temperature exceeds 700°F.

4.4.5 Containment Isolation

Failure to isolate refers to several accident sequences that involve a mechanical or operational failure to achieve containment isolation prior to the onset of core damage.

As described in section 4.1.2, only one of the two series isolation valves (inboard/outboard) is required to close to effect isolation. A Fault Tree (section 3.2.1.2) considering instrumentation power dependency, operator actions and valve failure was used to evaluate the probability that at least one of these valves would move to the required position early during an event, and thus successfully complete its safety function. This Fault Tree was used for all accident scenarios except for Station Blackout (SBO) when motive power would not be available. This method is probably conservative, considering the results of the following paragraph for SBO sequences.

An analysis was performed for each motor operated containment isolation valve that is normally open during power operation, and would therefore not close during an SBO. The results of this analysis showed only one penetration, containing valves 1FC007 and 1FC008, which is the line between the upper pool skimmers and Fuel Pool Cooling and Cleanup surge tank, that could be a potential bypass pathway and would require operator action to isolate. Existing Emergency Operating Procedures address operator actions to check and manually close, if necessary, isolation valve 1FC008 located in this line. All other valves are either required to be open during accident sequences or are part of a closed-loop which would prevent release of containment atmosphere to the environment.

Failure of containment to isolate is modeled as a branch in the CPS IPE Containment Event Trees.

4.4.6 Direct Containment Heating

Direct containment heating (DCH) is a potential early containment failure mode that would be expected to occur immediately after reactor vessel failure. The largest potential for the occurrence of direct containment heating is expected during core melt sequences that maintain a high (greater than 200 psia) reactor

vessel pressure until the time of vessel failure. The containment failure mechanism associated with direct containment heating is overpressurization of the containment shell due to rapid increases in gas temperatures as the corium energy and metal oxidation energy are released. The extent of pressurization depends upon the amount of debris which is discharged at vessel failure; the configuration of the plant which may enhance or hinder dispersal beyond the pedestal; the fraction of the debris which can be finely fragmented and dispersed throughout the containment atmosphere; and the ability of debris to transfer heat into various areas of containment.

BWR Mark III containments have several design characteristics that significantly limit the magnitude of the pressure rise associated with direct containment heating among which are:

- Suppression Pool
- Reactor Depressurization System

The most significant means of preventing direct containment heating is to assure reactor depressurization (<200 psia). The CPS plant has sixteen SRVs, any one of which is capable of assuring low reactor pressure at the time of vessel penetration. The CETs explicitly account for the potential for depressurization with this system. The effects of direct containment heating apply only to those accident sequences in which depressurization is unsuccessful.

The CPS containment also has the suppression pool to absorb the heat that is released from the reactor during blowdown. The suppression pool is very effective at removing the debris mass and energy during the blowdown phase. Because of the rapid flows, however, there could be a certain amount of debris that escapes the scrubbing effect of the pool during the initial blowdown phase. The method by which this could occur is that aerosols could be trapped within gas bubbles that do not condense

or collapse during travel through the suppression pool. The mass of debris aerosols would be small, and likely to have been cooled somewhat by radiative heat transfer, thereby reducing the energy escaping the water scrubbing. Any impact on the thermal-hydraulic effects downstream of the suppression pool are not expected to be significant since essentially all of the energy from the debris will remain in the pool.

A calculation was performed in order to quantify the suppression pool temperature following a reactor vessel breach at high pressure. The assumptions used in this calculation were that $\frac{1}{4}$ the core, $\frac{1}{4}$ the lower core plate and $\frac{1}{4}$ the lower vessel head were ejected; the suppression pool is at an initial temperature of 122.5°F; and all debris energy is transferred directly to the suppression pool, with no energy lost to surrounding structures. The results of this calculation shows a suppression pool temperature increase of only 22.2°F.

This increase does not raise the temperature of the suppression pool to saturation temperature and, therefore, is not expected to produce any corresponding containment pressurization effects.

DCH is not regarded as a significant containment integrity challenge for the CPS plant, based on the results of the above bounding calculations which show that for core melt and vessel failure, this phenomenon will not lead to suppression pool saturation.

4.4.7 Molten Core-Concrete Interaction

Molten core debris ejected from a failed reactor vessel would come into contact with the containment floor and may eventually erode a large enough volume of concrete that either (1) the reactor pedestal walls would lose their load-carrying capability; (2) the basement would be penetrated and core debris would exit the containment; or (3) sufficient non-condensable gases would be

generated to fail the containment on overpressure. The effect of non-condensable gas build up is implicitly included in the pressure calculations in MAAP and is not discussed further here.

Extensive erosion of concrete by high temperature core debris is a potential late containment failure mechanism that would be expected to occur many hours after reactor vessel failure and debris release into the containment. Two failure mechanisms are discussed as a result of concrete erosion, one is penetration of the containment basemat and the other is sufficient deterioration of the load-carrying capability of the pedestal walls that the reactor vessel moves and causes gross mechanical failures of penetrations for piping connected to the reactor vessel. Both of these containment failure mechanisms would be expected to result in large containment failure areas.

In a BWR Mark III plant, the concrete surface that experiences the most severe thermal attack is the pedestal floor. The heat transfer between the core debris and concrete drives the thermal decomposition and erosion of the concrete. The thermal attack on the concrete can be broken up into three different phases:

1. a short-term, localized attack as debris leaves the reactor pressure vessel;
2. an aggressive attack by high-temperature debris immediately after the core material leaves the reactor; and
3. a long-term attack in which the debris temperature would remain essentially constant and the rate of attack is determined by the internal heat generation.

Of the three different phases of thermal attack, the long term behavior is the process which ultimately results in threatening containment integrity.

4.4.7.1. Localized Attack

Immediately after vessel failure, debris is discharged from the vessel into the pedestal region. This molten material induces an aggressive localized jet attack upon the concrete surface. The thermal attack is confined to the area where the jet impinges. Estimates of this attack based on analyses show the eroded depth to be perhaps 10 to 20 centimeters, depending upon the primary system conditions at vessel failure. This phase is the least damaging of the three phases, and no failures result during this phase.

4.4.7.2 Attack by High-Temperature Debris

After the jet attack, the reactor cavity or pedestal region may be covered by high-temperature debris which aggressively attacks the concrete substrate. Free water, bound water, and other gases generated by concrete decomposition are then released. The gases agitate the melted material and promote convective heat transfer between the debris and the concrete. The aggressive attack generally absorbs more energy than is generated by the decay power. Additional internal heat generation in the melt can result from the oxidation of metallic constituents by the gases released from the concrete substrate.

Typically, the high-temperature, aggressive attack is driven by the internal heat generation from metal oxidation and to a lesser extent by the initial stored energy of the debris. This phase of concrete attack terminates when metal oxidation is completed. The calculated depth of concrete erosion in the pedestal area at this time is 1.71 feet and in the floor drain sump, 2.34 feet.

4.4.7.3 Long-Term Attack

During the long-term attack, the debris remains at an essentially constant temperature, and the rate of attack is determined by the difference between the internal heat generation and the heat losses to the containment environment. These heat losses are principally due to convection of high-temperature gases throughout the containment. The resulting concrete attack rate is much reduced from that typical of the high-temperature attack phase and occurs over a much longer interval.

It is assumed that all of the corium will deposit in the pedestal cavity and, via 6" interconnecting piping, in the floor drain sump. This assumption yields a melt depth in the pedestal cavity of 14.6 inches and in the floor drain sump, of 49.6 inches. The depth of molten debris bed in both the pedestal and floor drain sump are greater than the NRC defined coolable depth of 25 cm (approximately 10 inches). Volumetrically, 62% of the corium remains in the pedestal cavity and the remaining 38% is in the floor drain sump (including interconnecting piping).

As previously stated, the core-concrete interaction is hypothesized to be able to cause containment failure by weakening the reactor pedestal sufficiently that the reactor vessel and attached piping moves and tears out associated penetrations through the drywell and containment shells, or by penetrating the containment floor through the basemat.

The likelihood of experiencing the first of these potential failure modes, pedestal wall weakening, is expected to be negligible in BWR plants equipped with Mark III containments, including CPS, due to the unique pedestal region geometry involved. The floor elevation of the pedestal region is far below that of the drywell floor; for CPS, the difference is 8.1 feet. In contrast, the greatest pedestal debris depth is expected to account for less than 10% of this difference, or less

than 1.25 feet. It can be inferred from this situation that even assuming that sideward MCCI concrete erosion proceeds horizontally across the entire width of the pedestal wall, 5.67 feet in CPS case, the pedestal wall will remain physically attached to the drywell floor across a vertical distance of at least 6 feet around the entire circumference. For a failure to occur, wall loading due to its own deadweight and that of the reactor vessel, biological shield, and other miscellaneous attached structures would have to generate shear stresses of sufficient magnitude to fail both the concrete and the imbedded steel reinforcing rods over the entire vertical attachment area between the pedestal wall and the drywell floor concrete. A thorough review of the applicable containment structural drawings, as well as direct observations made during the CPS primary containment walkdown, do not support the assumption that the potential shear loads would approach such levels. Although a detailed and exhaustive structural analysis of this topic has not been performed, the information available fully supports a judgement that MCCI sideward erosion will not significantly jeopardize the pedestal walls' vertical load carrying capability, and thus this particular failure mode need not be considered further.

Because of the assumption that the corium goes into the pedestal and flows to the Reactor Floor (RF) sump after vessel failure, the corium is split between the pedestal and the sump. The elevation of the top of the corium is the same in both locations, but the depths of the corium are different because of different concrete elevations. The thickness of the basemat at these points is 10.2 feet under the sump and 13.2 feet under the pedestal.

Calculations show containment failure by basemat penetration (assuming non-coolable debris beds) in the pedestal cavity area would occur in 19.8 days, and in the floor drain sump area, in 8.1 days. Considering the lesser, 8.1 days, its magnitude

clearly suggests that the potential for MCCI induced fission product releases from the primary containment would exist only long after much more rapidly occurring mechanisms, such as containment pressurization, have precipitated containment failure.

Considering the magnitude of this estimate, combined with the vast amount of concrete erosion that must take place (in both downward and sideward directions) to reach basemat penetration, there is some doubt about the validity of the basic assumption that initially non-coolable debris beds will remain uncoolable until containment breach occurs. As the debris bed grows by incorporating concrete decomposition products, its surface area to volume ratio will increase and the decay power concentration will be diluted. It is therefore imperative to examine the alternative outcome, specifically that initially non-coolable debris beds could at some later point acquire a coolable configuration, thus allowing for the potential to terminate MCCI prior to containment breach.

An evaluation was performed using CPS specific data to determine if a coolable configuration may be attained at some time following the initial melt and prior to basemat penetration. The results of this evaluation concluded that it is highly likely that a coolable configuration would be attained after 3.78 days in the pedestal cavity area during which time 3.76 feet of basemat erosion had occurred. A coolable configuration for the floor drain sump would occur in 7 days at which time 9.35 feet of the 10.2 foot thick basemat had been eroded. This coolable configuration was based on melt spread into sideways eroded areas, upward heat losses to drywell atmosphere from an increased surface area, debris decay power decline over time, and the ability of exposed concrete areas to accept additional decay power over an extended time.

It was also observed during the MCCI evaluation that aside from the containment failure timing question, the possibility that initially non-coolable debris beds could become coolable later can have a bearing on the overall number and location of containment release paths that may arise during severe accident sequences. If the debris can be cooled prior to basemat penetration as the CPS evaluation suggests, releases will be limited to gas space paths caused by phenomena other than MCCI. conversely, should the debris remain non-coolable or if actions are not taken to assure that an adequate flow of cooling water is provided to the debris beds to compensate for boil off, additional releases to the ground below the basemat could eventually occur. In the CPS case however, all indications are that such an outcome would be unlikely.

For the majority of sequences, sufficient amounts of water will either exist in the pedestal cavity prior to vessel failure or will enter this cavity (with the debris) through the failed vessel to initially quench the debris. Energy removed from the debris beds in this fashion was not deducted from either the MCCI containment failure timing or termination evaluations. In addition, there are several CPS cooling water supplies, including firewater, that are thoroughly addressed in the plant's Emergency Operating Procedures (EOPs). An extensive time period is expected to be available (a maximum of 8.1 days) for actions to recover and activate these facilities, and there is strong evidence that the debris will become coolable well within this time frame (at least 24 hours). The overall situation thus indicates that the likelihood of realizing MCCI induced basemat penetration and related fission product releases is sufficiently remote to eliminate the need for MCCI nodalization in the CPS CETs.

4.4.8 Hydrogen Combustion

Hydrogen combustion is one of two events with the potential for raising containment pressure to the failure point.

The Hydrogen Igniters are expected to remain operable during all events with the exception of SBO, thus limiting hydrogen combustion to localized burns instead of global burns and detonation. The probability of failure of the hydrogen igniters has been modeled by a Fault Tree (section 3.2.1.12)

Hydrogen ignition early in an SBO (within about the first 4 hours) will not result in containment failure because of the limited time for hydrogen generation. Hydrogen ignition later in an SBO or in other sequences with failed igniters could result in failure of the containment. When this would occur is a function of the containment ambient pressure and the hydrogen concentration just before hydrogen ignition. Emergency Operations Procedure EOP-7 directs operations personnel to de-energize (or not energize) Hydrogen Igniters if the hydrogen concentration is unknown or if the hydrogen concentration exceeds the deflagration limits for a given containment pressure. This analysis agrees with the HCOG position on hydrogen detonation at BWR Mark III containments.

A node for hydrogen control has been included in the Containment Event Trees.

4.4.9 Containment Overpressurization

Explicit consideration was given to the potential for containment pressurization from various sources depending on the characteristics of the accident sequence in question. Pressurization challenges to the containment include the following:

- * Vessel blowdown (4.4.2)
- * Steam generation from ATWS (SRVs)
- * Ex-vessel steam explosion (4.4.3)
- * Hydrogen combustion (4.4.8)
- * Non-Condensable gases produced by molten core-concrete interaction (MCCI) (4.4.7)
- * Steam generation from decay heat

Only two of these events, hydrogen combustion and steam generation from ATWS, were found to have any likely capability of raising containment pressure to the failure point within the first 48 hours after event initiation.

Failure of containment from hydrogen combustion could occur under certain circumstances as early as 4 hours after event initiation, and failure from steam generation due to ATWS could occur approximately 2 hours after event initiation.

Each of the components believed to be controlling the containment ultimate pressure capability were evaluated in order to determine a best estimate failure pressure along with any uncertainties associated with each location. The CPS USAR overpressurization analysis, section 3.8.1.4.8, (which is based on Sargent and Lundy calculations for containment and Chicago Bridge & Iron assessments of the containment Equipment Hatch and Personnel Airlocks), and the results of Sandia National Laboratory 1/6th scale test of Reinforced Concrete Containments were used as the basis for probable failure locations and pressures.

The results of these evaluations were that the containment would have a 50% probability of failure at 93.8 psig, with the most likely failure mode being a tear in the liner in the vicinity of a containment penetration. The containment shell (rebar) is estimated to begin yielding at 95 psig at the hoop reinforcement at mid-height of containment, and be expected to fail (break) at

a significantly higher pressure. The containment equipment hatch and personnel airlocks were both estimated to have capabilities beyond that of the containment liner. Because of the large uncertainties associated with the foregoing estimates it is difficult to predict a specific failure location and failure pressure. Therefore, the estimated capabilities of the various controlling components along with the uncertainties associated with these estimates were combined using Monte Carlo methods to obtain the cumulative failure probability curve shown in Figure 4.4-1.

As stated earlier in this report, the CPS Containment is particularly robust because of the close spacing of reinforcing steel (i.e. 12 in center-lines). The phenomenological considerations are also not as critical because of the larger volume and lower power than other BWR-6s.

For purposes of assigning a generalized size to the containment breach, the following assumptions can be made. Failures of the containment shell or equipment hatch can be assumed to be gross failures, i.e., large failure that would rapidly depressurize the containment. Failures of the containment liner can be assumed to be limited in size, such that further containment pressurization would be prevented, or a gradual containment depressurization may occur.

The equipment hatch and shell failure locations are above the suppression pool and as such would result in a "scrubbed" release. Liner failures are more likely to occur above the suppression pool surface because the stainless steel liner in the suppression pool is more ductile than the carbon steel of which the rest of the liner is made and the calculated radial containment wall deflections are larger at the mid-height of the containment compared to the suppression pool area. In addition, the number and complexity of mechanical penetrations below the suppression pool surface is less which would tend to make liner

failure less likely in the suppression pool. For these reasons it is assessed that 14% of the likely failures could be below the surface of the suppression pool and the remaining failures above the pool surface.

Containment Overpressurization is not included as a node in the Containment Event Trees (CETs). However, during quantification of the CETs, information from the probability distribution function was considered in each sequence to determine the final containment end state.

Table 4.4-1

Drywell and Containment Penetration Elastomers

<u>Material</u>	<u>Tested Temp</u>	<u>Expected Temp</u>	<u>Calculated Life</u>
<u>Drywell</u>			
Bisco SF-150NH	1900°F	700°F	8.14 yrs.
Silicone Rubber	437°F	700°F	17.8 days
<u>Containment</u>			
Bisco LOCASEAL	266°F	300°F	503.74 days
Viton	600°F	300°F	107.7 yrs.
Kapton	572°F	300°F	1.1E9 yrs
Polysulfane	410°F	300°F	9.0E2 yrs.

CUMULATIVE PROBABILITY DISTRIBUTION FUNCTION
FOR FAILURE OF THE CPS CONTAINMENT

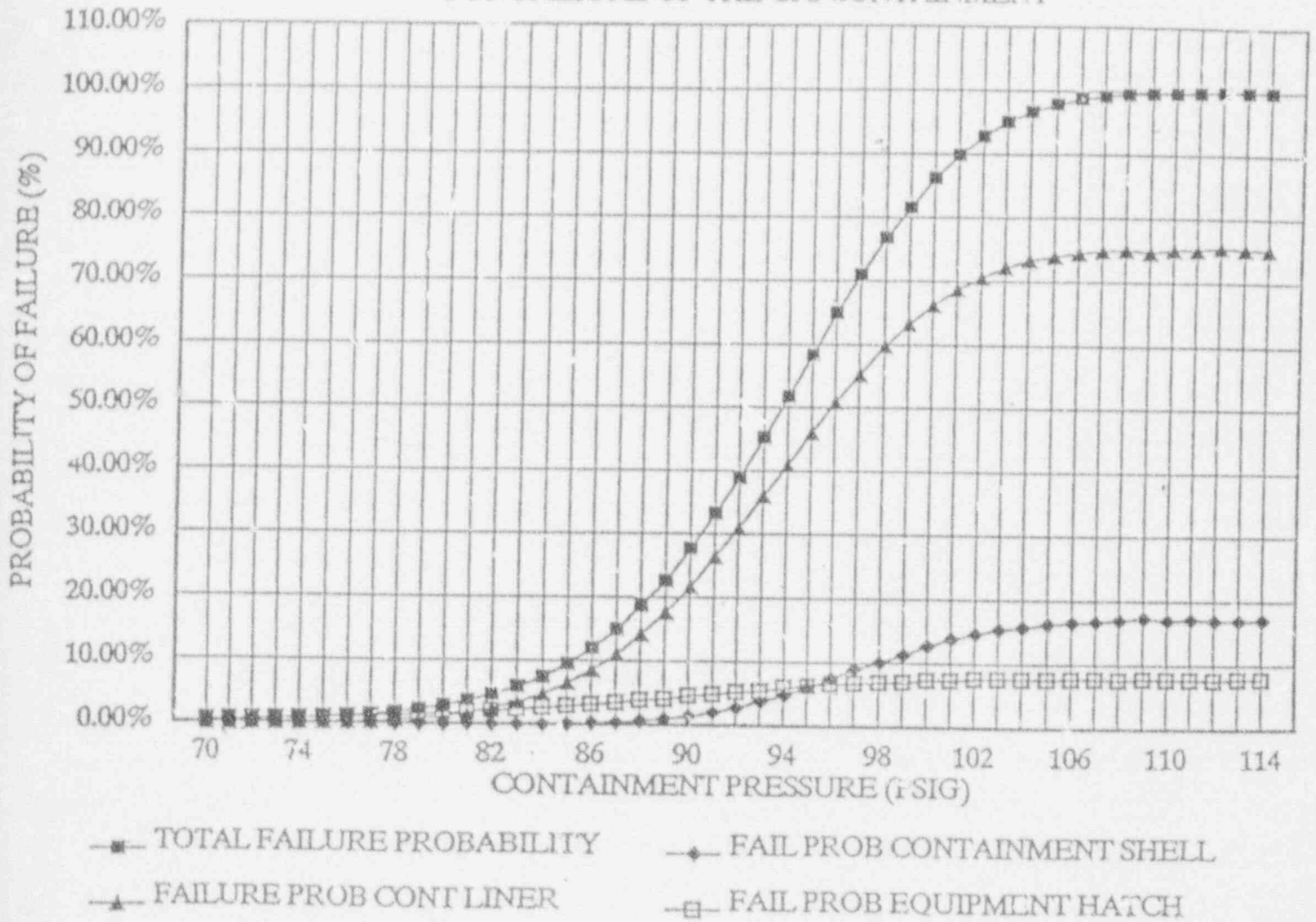

Figure 4.4-1
Cumulative Probability Distribution Function
For Failure of the CPS Containment

4.5 Containment Event Trees

4.5.1 Introduction

As discussed in section 4.3.1, the general approach used in the construction of the CETs was to include headings for events and parameters that plant operators could detect or control.

Progression through the CETs eventually reaches a plant damage state (PDS) (CET end state). Each plant damage state is represented by a four letter code which identifies RPV and containment status as well as sequence timing. The plant damage state codes were presented earlier in Table 4.3-3.

For sequences in which containment failure occurs, the release mode is also determined for use in the calculation of the radionuclide release source term. A matrix classifying possible release modes was presented earlier in Table 4.3-4. The method for categorizing source terms was presented in section 4.

As discussed in section 4.3.2, PC SETS was used to evaluate the branch and sequence frequencies of the Containment Event Trees. Systems such as containment venting and hydrogen ignition that were not included in the level 1 PRA were modeled and analyzed for their effect on containment performance.

The Modular Accident Analysis Program (MAAP) code was used to determine CET sequence timing as well as plant damage states, release modes and radionuclide release source terms for the sequences that survived frequency truncation.

CETs have been prepared to address each level 1 PRA accident class. The event tree headings, assumptions, plant damage states, and release modes are described in the following paragraphs.

4.5.2 CET Headings

This section discusses the headings used in the CETs. The headings describe actions or events which plant operators could detect or control and that have a direct effect on containment performance.

CONTAINMENT ISOLATION - Applicable to CET IA, IB, ID, IIIB, and IIIC. This branch addresses the closure of all required containment isolation valves. If all valves in a given penetration fail to close, the containment is assumed breached. Actuation of either one of the series valves (inboard or outboard) for all penetrations is required for success in this heading. For CET IB (SBO), when motive power is not available, only one valve, 1FC008 - Outboard isolation valve on the line from the upper pool skimmers to the Fuel Pool Cooling and Cleanup (FC) surge tank, was cause for concern because it is not part of a closed-loop system and it is normally open. CPS ECPs direct verifying all isolations and manually closing any valves that have not closed.

REACTOR DEPRESSURIZATION - Applicable to CET IA, IB, IIIB, and IV. This branch addresses reactor depressurization prior to the core slumping to the bottom head. Even though core melt has begun, recovery of ADs and operation of low pressure injection systems could terminate core melt within the vessel in a manner similar to the way the core melt sequence at Three Mile Island occurred. Failing arrest of damage in-vessel, depressurization would limit the containment pressure spike should vessel failure occur.

INJECTION PRIOR TO VESSEL FAILURE - Application to CET IA, IB, ID, IIIB, IIIC, and IV. This branch addresses injection into the reactor vessel prior to vessel failure. Repair/recovery of injection systems could allow termination of core melt within the

vessel or provide enough cooling to prevent containment failure. Systems considered in this branch for all CETs are HPCS, FW, LPCS, LPCI, CD, CB and CRD. Success for this heading is injection within 72 minutes from event initiation.

LATE INJECTION - Applicable to CET IA, ID, IIIB, IIIC. This branch addresses delayed injection into the reactor vessel. Injection is delayed for either repair or recovery of systems that would normally be available, or due to delay in lining up a system for injection. Injection via the vessel onto core debris below the vessel could provide enough cooling to prevent containment failure. Based on MAAP runs, a delay of 4 hours was used before injection begins. Systems considered in this branch are HPCS, FW, LPCS, LPCI, CD, CB, FP and CRD.

CONTAINMENT SPRAY IN EVENT OF POOL BYPASS - Applicable to CET IA, IB, ID, IIIB, IIIC and IV. This branch addresses initiation of the containment spray mode of RHR. The use of containment sprays can have a strong effect on any subsequent release due to radionuclide scrubbing in the containment airspace.

HYDROGEN GAS CONTROL - Applicable to CET IA, ID, IIIB and IIIC. This branch addresses the availability of hydrogen ignitors, and is included because hydrogen control has a strong effect on containment performance and any subsequent release source term. For CET IB (SBO), success for this heading is disabling the ignitors prior to recovery of AC power, and not energizing ignitors if hydrogen concentrations are too high, or are unknown.

CONTAINMENT VENTING - Applicable to CET IA, IB, ID, IIIB, and IIIC. This branch addresses the availability of containment venting capability. Selectively venting the containment, rather than allowing the containment to fail, has a great impact on the radionuclide release mode.

CONTAINMENT FAILS ABOVE SUPPRESSION POOL - Applicable to CET IA, IB, ID, IIIB, IIIC and IV. This branch addresses the potential for the containment to fail above, rather than below, the surface of the suppression pool. Failure of containment with concurrent loss of the suppression pool greatly affects the radionuclide release source term and containment heat removal capability.

LONG TERM HEAT REMOVAL - Applicable to CET IA, IB, ID, IIIB, IIIC and IV. This branch primarily addresses the availability of the suppression pool cooling mode of RHR for sustained operation following an accident. Other methods of heat removal, such as containment flooding, fuel pool cooling, feed and bleed, etc. within 48 hours of event initiation, also contribute to success in this heading.

AC POWER RECOVERY TO PREVENT VESSEL FAILURE - Applicable to CET IB (SBO) only. This branch addresses the recovery of AC power in time to prevent vessel failure. Success in this heading is recovery of AC power within 40 minutes from event initiation. Several additional MAAP runs confirm the 40 minutes is a conservative interval.

LATE POWER RECOVERY AND INJECTION - Applicable to CET IB (SBO) only. This branch addresses AC power recovery and injection into the reactor vessel in time to avoid containment failure. Injection is delayed for either repair and recovery of systems that would normally be available, or due to delays in lining up a system for injection. Injection via the vessel onto core debris below the vessel could provide enough cooling to prevent containment failure. Based on MAAP runs, a delay of 4 hours was used before injection begins. Systems considered in this branch are HPCS, FW, LPCS, LPCI, CD, CB, FP, and CRD.

SUPPRESSION POOL COOLING - Applicable to CET IV (ATWS) only - This branch addresses the immediate availability of the suppression pool cooling mode of RHR.

4.5.3 Containment Event Trees

The containment event trees for all accident classes are shown on Figures 4.5-1 through 4.5-6. Note that there is no CET for accident class V because all of these sequences truncated out during the level 1 analysis.

4.5.4 Assumptions

Significant assumptions used in the CETs were previously identified in section 4.2.2.

4.5.5 Plant Damage States

Potential damage states for the various CET sequences are shown on Table 4.3-3. The actual end states for the significant sequences are included on the CETs.

4.5.6 Release Modes

The release mode is used to describe the type of release for use in calculating the radionuclide source term. Table 4.3-4 contains the matrix of potential release modes. Sequence release modes are included on the CETs.

4.5.7 Source Terms

The source term release category is based on the amount of core material released outside the containment. Table 4.3-5 describes the source term release categories. Source term release categories are included on the CETs.

Class IA CET

CLASS IA CET (9 PE- 6)	CONTAINMEN T ISOLATION	REACTOR DEPRESSURI ZATION	INJECTION PRIOR TO VESSEL FAILURE	LATE INJECTION	CT SPRAY IN EVENT OF POOL BYPASS	HYDROGEN GAS CONTROL	CONTAINMEN T VENTING	CT FAILS ABOVE SUPP POOL	LONG TERM HEAT REMOVAL	POS	SEQUENCE DESCRIPTION	SEQ. PF. JB	REL. MODE	SRC. TERM.
	M	G	F	E	C	D	B	A						
	RXXX	IA01	1.6E-7	AD	NR									
		IA02	<1.0E-9											
		IA03	<1.0E-9											
		IA04	<1.0E-9											
	RXXX	IA05	2.69E-6	AD	NR									
		IA06	<1.0E-9											
		IA07	<1.0E-9											
	HXXX	IA08	4.72E-6	AD	NR									
		IA09	<1.0E-9											
		IA10	<1.0E-9											
		IA11	<1.0E-9											
		IA12	<1.0E-9											
		IA13	<1.0E-9											
		IA14	<1.0E-9											
		IA15	<1.0E-9											

CLASS IA CET - This CET begins with the containment building intact at the time core melt begins. The reactor vessel is at high pressure. The core melt at high pressure sequences from all non-LOCA non-ATWS transient initiators in the level 1 PRA were combined to establish the input frequency for this CET.

Figure 4.5-1

Class IB CET

CLASS IB CET (9 SE- 8)	AC POWER & DELIVERY TO PREVENT V ESSEL FAIL	CONTAINMEN T ISOLATION	REACTOR DEPRESSURI ZATION	INJECTION PRIOR TO VESSEL FAILURE	LATE POWER RECOVERY & INJECTION	DI SPRAY IN EVENT OF POOL BYPASS	HYDROGEN GAS CONTROL	CONTAINMEN T VENTING	NHT P (1) 0 AE 1/2 SUPP POOL	LONG TERM HEAT REMOVAL	POS	SEQUENCE DESCRIPTION	SEQ PROB	RCL MODE	SRC TERM
	I	H	G	F	E	C1	D	B	A						
											RXXX	TL01	7.56E-6	A0	NR
												TL02	<1.0E-9		
												TL03	<1.0E-9		
												TL04	<1.0E-9		
												TL05	<1.0E-9		
												TL06	<1.0E-9		
												TL07	<1.0E-9		
												TL08	<1.0E-9		
												TL09	<1.0E-9		
												TL14	1.27E-6	A0	NR
												TL15	<1.0E-9		
												TL16	1.57E-7	A0	NR
												TL17	<1.0E-9		
												TL19	<1.0E-9		
	HVBI	TL51	4.10E-7	D5	III										
	HDHI	TL52	3.74E-8	D6	III										
	HDHI	TL53	1.55E-9	D6	III										
	HCIE	TL54	7.03E-7	A1	III										

CLASS IB CET - This CET begins with the containment building intact at the time core melt begins. A station blackout condition exists. The core melt sequences from the level 1 PRA that include the loss of off-site power and failure of the Division I and II diesels are combined to determine the input frequency for this CET

Figure 4.5-2

Class ID CCT

CLASS ID CET 15 7E-6)	CONTAINMENT ISOLATION	INJECTION PRIOR TO VESSEL FAILURE	LA E INJECTION	CT SPRAY IN EVENT OF POOL BYPASS	HYDROGEN GAS CONTROL	CONTAINMENT VENTING	DNMT FAILS ABOVE SUPP POOL	LONG TERM HEAT REMOVAL	POS	SEQUENCE DESCRIPTION	SEQ PROB	REL MODE	SRC TERM
	H	F	E	C1	D	B	A						
									RXXX	ID01	3.08E-6	AO	NR
										ID02	<1.0E-9		
										ID03	<1.0E-9		
										ID14	<1.0E-9		
										ID15	<1.0E-9		
										ID16	<1.0E-9		
									LXXX	ID41	2.83E-8	AO	NR
										ID42	<1.0E-9		
										ID43	<1.0E-9		
									LXXX	ID47	1.73E-8	AO	NR
										ID48	<1.0E-9		
									LXXX	ID49	9.76E-8	AO	NR
										ID50	<1.0E-9		
										ID51	<1.0E-9		

CLASS ID CET - This CET begins with the containment building intact at the time core melt begins. The reactor vessel is at low pressure. The various core melt at low pressure sequences from all non-LOCA non-ATWS transient initiators in the level 1 PRA were combined to establish the input frequency for this CET.

Figure 4.5-3

Class IIB CET

CLASS IIB CET (1.3E-4)	CONTAINMENT ISOLATION	REACTOR DEPRESSURIZATION	INJECTION PRIOR TO VESSEL FAILURE	LATE INJECTION	CT SPRAY IN EVENT OF POOL BYPASS	HYDROGEN GAS CONTROL	CONTAINMENT VENTING	TWMT FAILS ABOVE SUPR POOL	LONG TERM HEAT REMOVAL	POS	SEQUENCE DESCRIPTION	SEQ PROB	REL MODE	SAC TERM
	H	G	F	E	C1	D	B	A						
										LB01	<1 0E-9			
										LB02	<1 0E-9			
										LB03	<1 0E-9			
										LB15	<1 0E-9			
										HXXX	LB26	3.45E-9	AD	NR
										LB27	<1 0E-9			
										LB28	<1 0E-9			
										HXXX	LB31	1.08E-9	AD	NR
										LB32	<1 0E-9			
										LB33	<1 0E-9			
LB34	<1 0E-9													
LB50	<1 0E-9													

CLASS IIB CET - This CET begins with the small to medium sized LOCA that does not depressurize the reactor vessel. The various level I PRA core melt sequences involving LOCAs that do not depressurize the vessel were combined to determine the input frequency for this CET.

Figure 4.5-4

Class IIIC CET

CLASS IIIC CET (1.1E-8)	CONTAINMENT ISOLATION	INJECTION PRIOR TO VESSEL FAILURE	LATE INJECTION	CT SPRAY IN EVENT OF POOL BYPASS	HYDROGEN GAS CONTROL	CONTAINMENT VENTING	DNMT FAILS ABOVE SUPP POOL	LONG TERM HEAT REMOVAL	POS	SEQUENCE DESCRIPTION	SEQ PROB	REL MODE	SRC TERM
	H	F	E	C1	D	B	A						
									LXXX	LC01	9.00E-7	AD	NR
										LC02	<1.0E-9		
										LC03	<1.0E-9		
										LC14	<1.0E-9		
										LC15	<1.0E-9		
										LC16	<1.0E-9		
										LC37	<1.0E-9		
									LXXX	LC42	2.08E-8	AD	NR
										LC43	<1.0E-9		
										LC44	<1.0E-9		
	LC46	<1.0E-9											
	LC50	<1.0E-9											

CLASS IIIC CET - This CET begins with the medium to large sized LOCA which depressurizes the reactor vessel or a small LOCA with successful depressurization. The various level 1 PRA core melt sequences involving LOCAs that depressurize the reactor vessel were combined to determine the input frequency for this CET.

Figure 4.5-5

Class IV CET

CLASS IV EVENT (ATWS) (1.4E-7)	DNNT FAILS ABOVE SUPP POOL	REACTOR DEPRESSURIZATION	INJECTION PRIOR TO VESSEL FAILURE	CT SPRAY IN EVENT OF POOL BYPASS	SUPPRESSION POOL COOLING FAILURE	LONG TERM HEAT REMOVAL	POS	SEQUENCE DESCRIPTION	SEQ. PROB.	REL. MODE	SRI TERM
	A	B	F	D1	C						
							ROAE	AT01	1.20-7	C6	11
								AT02	<1.0E-9		
								AT03	<1.0E-9		
								AT04	<1.0E-9		
								AT05	<1.0E-9		
							ROAE	AT15	1.02E-8	C6	11
								AT40	<1.0E-9		
								AT50	<1.0E-9		

CLASS IV CET - This CET begins with an ATWS. The containment is assumed failed from overpressure prior to core damage or vessel failure. The various ATWS sequences from all initiators were combined to determine the input frequency for this CET.

Figure 4.5-6

4.6 Accident Progression and CET Quantification

This section provides a brief description of the accident progression for any sequences in each CET that survived truncation at 1E-9/reactor year. This section also discusses specific containment sequence recovery actions since substantial time is available following core damage in which operators may respond and prevent or mitigate containment failure.

This section discusses the evaluations of significant CET sequences, the ones that survived truncation. The frequencies of all such sequences as well as their respective Plant Damage State (PDS), Release Modes (RM) and Source Terms (ST) are shown on the CETs (figures 4.5-1 through 4.5-6 of section 4.5).

4.6.1 Accident Progression

CET IA. High Pressure transient, non-LOCA, non-ATWS.

None of the three significant sequences in this CET result in a release from containment. In two of these sequences (IA01, IA15), recovery is probable in-vessel. The third sequence (IA30) is a vessel breach at high pressure (>200 psi) but the release is retained in the containment. Containment pressure resulting from this event reaches approximately 25 psia and is well below the containment failure pressure. Figures 4.6-1, 4.6-2 and 4.6-3 show containment pressure, containment, and drywell temperatures and containment hydrogen mass present for a typical sequence on this event tree (IA54).

CET IB. Station Blackout (SBO).

Four of the seven significant sequences in this CET result in a release from containment (TL51, 52, 53, 54). The first node for each of these sequences assumes failure to restore AC Power in time to prevent RPV breach. One of these sequences (TL54) is a containment isolation failure resulting in a category III

release. The second sequence (TL51) is a delayed containment venting release (manually initiated) which bypasses the suppression pool in order to prevent failure of the containment by overpressurization. This sequence results in a category II release. The remaining two sequences consider power recovery at 24 hours with an essentially simultaneous hydrogen burn that fails the containment by overpressurization. These sequences result in a Category III release. The only difference in these two sequences is failure above or below the surface of the suppression pool. Figures 4.6-4, 4.6-5, and 4.6-6, show the containment pressure, temperature, hydrogen mass present and drywell temperature for a typical sequence on this event tree (TL51). Procedures CPS 4200.01, "Loss of AC Power", and CPS 4411.06, "Emergency Containment Venting, Purging and Vacuum Relief", address operator actions to manually actuate valves during SBO events.

CET ID. Low Pressure Transient, non-LOCA, non-ATWS.

None of the four significant sequences in this CET result in a release from containment. In two of these sequences, (ID47 and ID49) containment venting is available if required, but is assumed unused since containment pressure only reaches 32.7 psia. In this CET, all of the sequences for which venting is unsuccessful truncated out. Various procedures address arresting core damage in-vessel. Assuming failure to arrest damage in-vessel, none of these sequences provide conditions sufficient to challenge the containment integrity. Figures 4.6-7, 4.6-8, and 4.6-9 show the containment pressure, temperature and hydrogen as well as drywell temperature for a typical sequence on this event tree (ID47).

CET IIIB. LOCA, RPV at high pressure (>200 psi).

This CET assumes a small to medium sized LOCA that does not depressurize the RPV along with failure to depressurize. Neither of the two significant sequences in this CET result in a release from containment. Failure of containment to isolate at the first node on this CET truncated out. EOP-1, "RPV Control"; EOP-2, "RPV Flooding"; EOP-3, "Emergency RPV Depressurization", and EOP-7, "Hydrogen Control" address actions to recover from this event. Figures 4.6-10, 4.6-11, and 4.6-12 show the containment pressure, temperature and hydrogen, and drywell temperature for a typical sequence on this Event Tree (LB31).

CET IIIC. Medium to large LOCA, RPV at Low Pressure (<200 psi). In this event, the LOCA is of sufficient size, or operator action is successful to depressurize the RPV. Only two of the identified sequences survived the truncation criteria, and neither of these result in a containment failure or release to the environment. As in CET IIIB, Containment Failure to Isolate at the first node truncated out. The same procedures identified for CET IIIB are also applicable for the various sequences in this CET. Figures 4.6-13 through 4.6-15 show containment pressure, containment and drywell temperatures and containment hydrogen mass for a representative sequence (LC42).

CET IV. ATWS

In this event, the containment is assumed to fail from overpressure prior to core damage or vessel breach. Only two of the identified sequences (AT01, AT15) are significant and result in releases from containment. Both failures are classified as large containment failures caused by overpressurization from SRV discharge to suppression pool. In one of these sequences (AT15) the containment is assumed to fail below the surface of the suppression pool, allowing a category III release. The other significant sequence is a containment failure above the level of

the suppression pool, resulting in a category II release. CPS procedures, CPS 4009.01, "Inadvertent Opening Safety/Relief Valve"; CPS 4411.06, "Emergency Containment Venting, Purging and Vacuum Relief"; CPS 4411.08, "Alternate Rod Insertion"; CPS 4411.10, "EOP Standby Liquid Control Operation"; EOP-1A, "ATWS RPV Control"; and EOP-3, "Emergency Depressurization", address actions to recover from these events. These procedures direct actions to prevent containment failure from overpressurization prior to reaching 45 psig. This value is well below the predicted containment failure pressure of 93.8 psig. Figures 4.6-16 and 4.6-17 show the containment pressure and temperature as well as the drywell temperature for a typical sequence (AT01).

Refer to section 4.2.1 for Plant Models used to support the Containment Event Trees.

4.6.2 Accident Sequence Recovery Actions, Post-Core Damage

Many of the systems used for mitigating an accident after core damage are the same ones that would have been used for preventing core damage. In the case that core damage has occurred, these systems must have failed. However, in evaluating the sequences for the containment Event Trees, additional time is available for recovery of these failed systems after core damage, but before vessel failure or in time to prevent containment failure. Recovery events may be applied to basic events which are recoverable over time in order to reflect the improved probability of success for these systems. Recovery by human intervention is addressed in the applicable Emergency Operating Procedure (Note: human error probabilities were developed to account for operator error in recoveries). CPS has fully implemented the recommendations of revision 4 of the BWROG Emergency Procedure Guidelines (EPG's) in its EOPs. The procedures have been fully verified and validated, and extensive

training of appropriate personnel (including simulator training) has been conducted. These procedural changes are incorporated into lesson plans for periodic training.

4.6.2.1 Power Recoveries to Prevent Reactor Vessel Failure Following Core Damage

Time-phased recoveries were employed for AC electrical power recovery in the level 1 part of the IPE (section 3.3.3.3). This resulted in different recoveries being applied to different sequences and cut sets in the station blackout sequences in the level 1 analysis. Different additional conditional recoveries were applied to the containment Event Tree analysis in order to be accurate and maintain consistency. Recovery probabilities are based on historical values from NUREG-1032, "Evaluation of Station Blackout Accidents at Nuclear Power Plants ... Final Report".

The derivation of recovery failure probabilities is done in cases for which 1) off-site power is not recovered within four hours, 2) battery load shedding is not successful and off-site power is not recovered within 1 hour, and 3) High pressure Core Spray (HPCS) and Reactor Core Isolation Cooling (RCIC) both fail and off-site power is not recovered within one-half hour. Both non-time-phased and time-phased recoveries were employed, as was done for the level 1 analysis.

The time available to recover AC power in order to recover injection systems in time to prevent reactor vessel failure following core damage for high pressure sequences is estimated at

1

IMAGE EVALUATION TEST TARGET (MT-3)

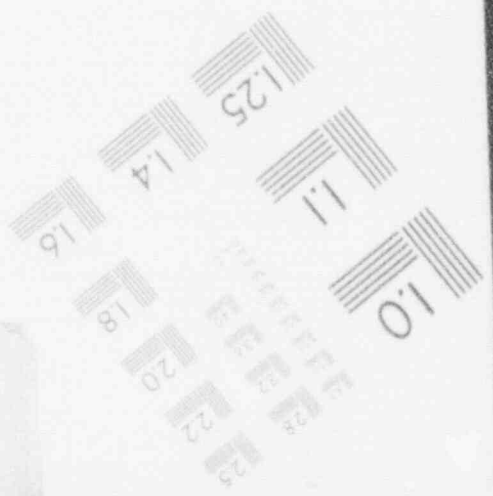
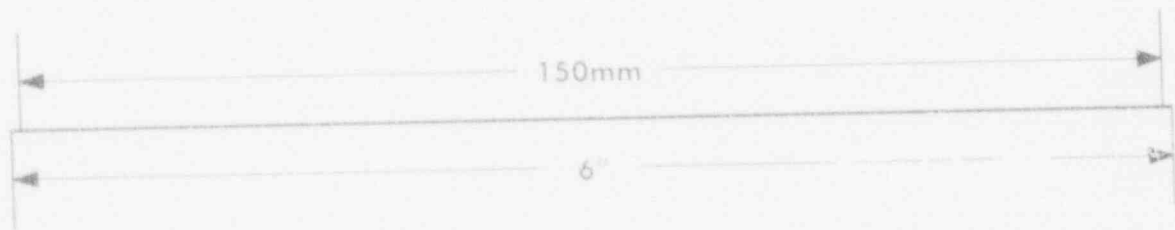
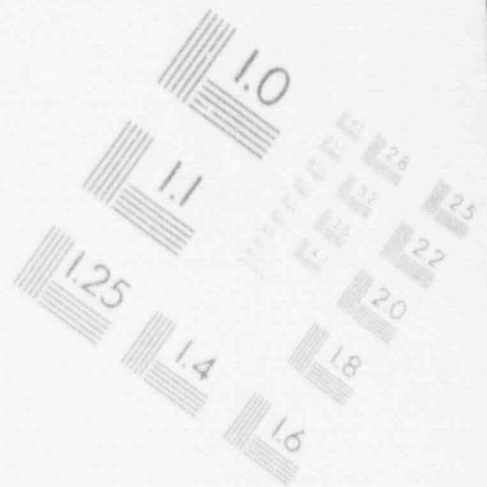
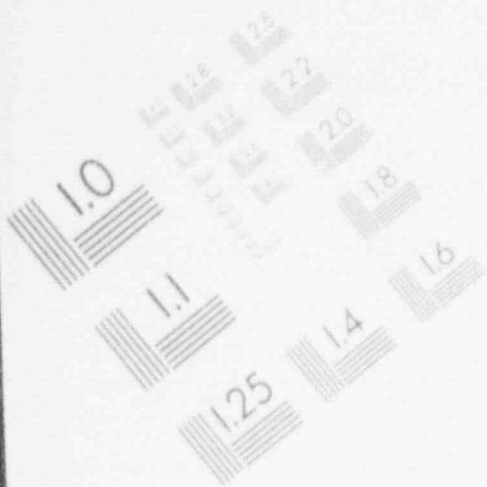

1

IMAGE EVALUATION TEST TARGET (MT-3)

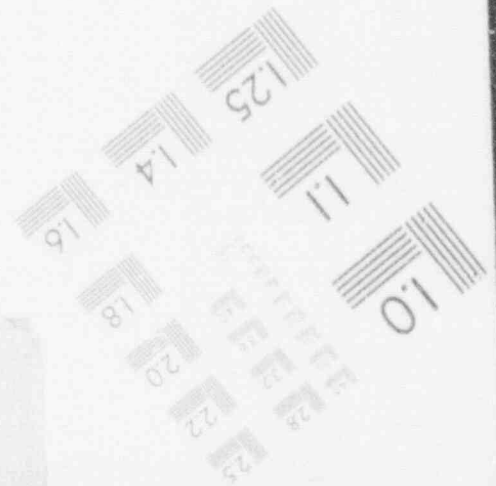
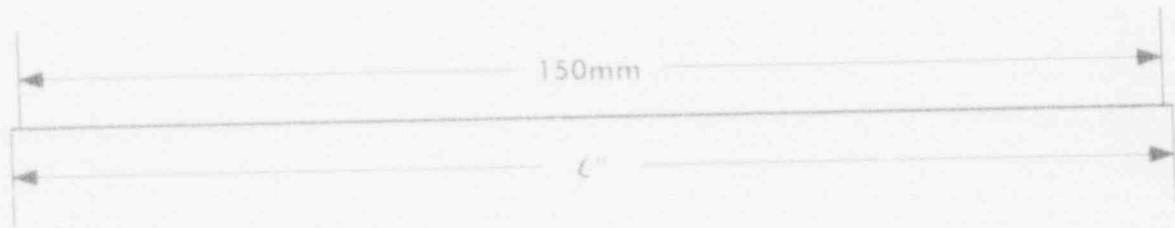
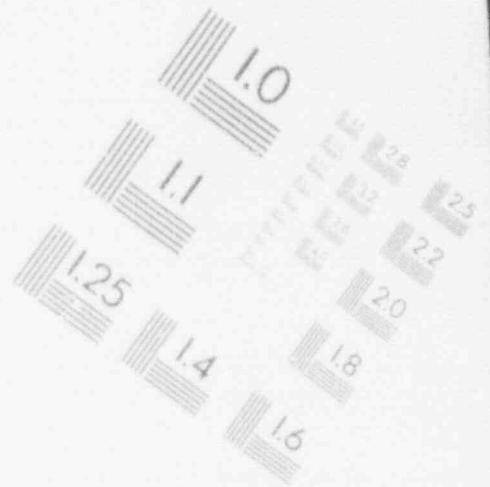
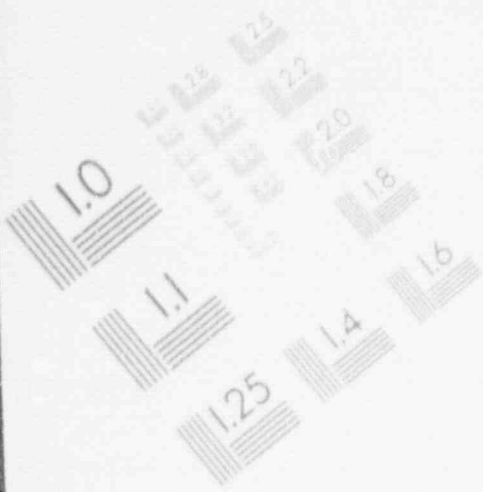

1

IMAGE EVALUATION TEST TARGET (MT-3)

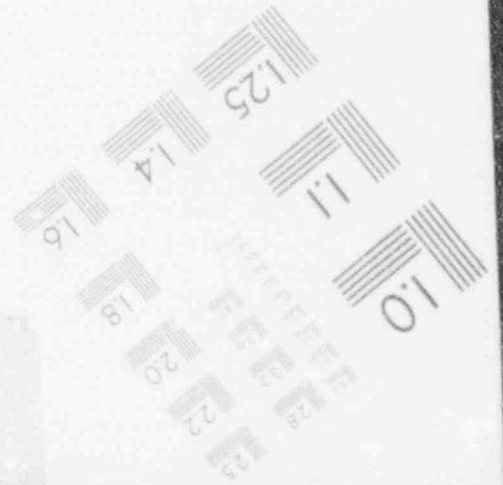
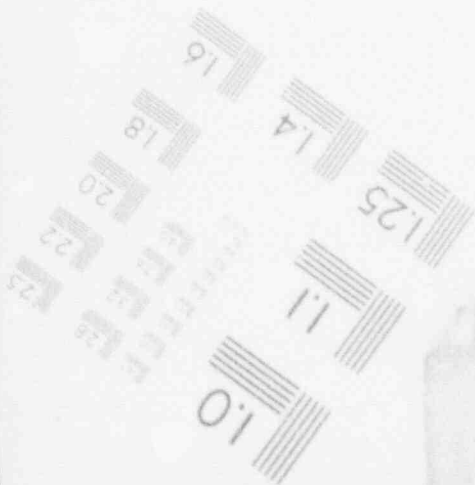
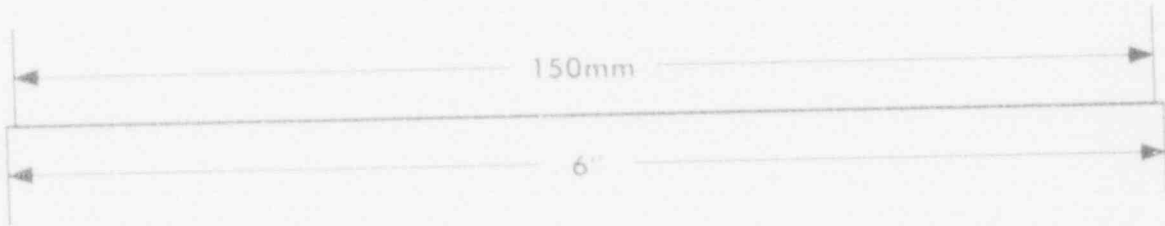
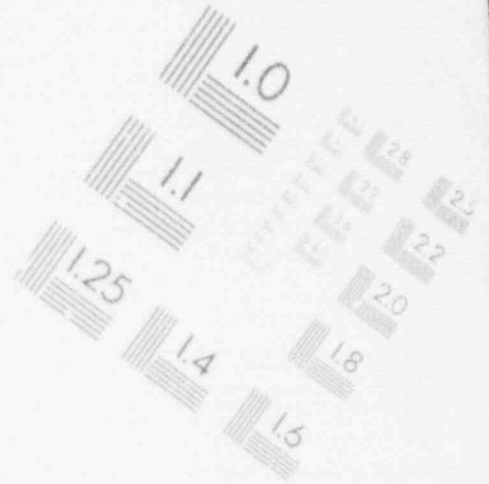
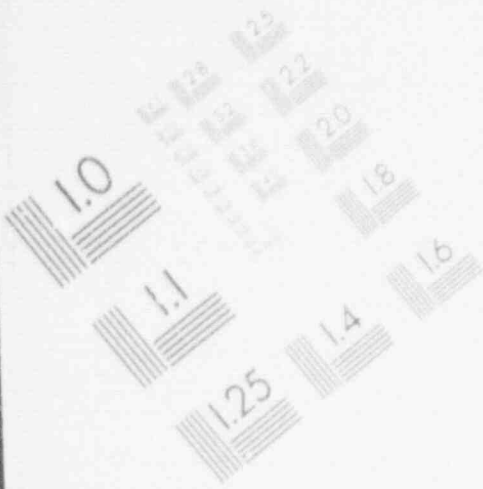

two hours. This was derived using MAAP, which shows that vessel failure occurs approximately 2.6 hours after the start of a station blackout.

Given that two hours¹ are available to recover off-site power to prevent reactor vessel failure once core damage has occurred, conditional probabilities were developed to extend the level 1 cases.

The time-phased recoveries of off-site power for the containment analysis follow the same pattern as they did for the level 1 sequences, keeping in mind that the recoveries at the later time are conditional on failure of recovery at the earlier times. Again, the recoveries must be sequence-dependent. The power recovery factors for combinations of loss of off site power and specific additional events are shown in Tables 4.6-1 and 4.6-2.

4.6.2.2 Power Recoveries to Prevent Containment Failure for Containment Event Trees in Which Containment Isolation is Successful or for Late Injection for Debris Cooling or Scrubbing on the Non-Isolated Cases

Power recovery at approximately 4 hours in a sequence is based on the time at which restoration would not result in containment failure from a global hydrogen burn. Restoring power beyond the 4 hour time frame could cause a hydrogen burn of sufficient magnitude to initiate a pressure spike which could fail containment. A conditional recovery failure probability of .469 was applied to the recovery at 4 hours.

¹ Some time is allotted to align systems once power is restored.

4.6.2.3 Recovery for Failure to Recover Injection Systems Before and After Reactor Vessel Failure Following Core Damage.

All of the sequences leading to core damage resulted from failure of injection systems or depressurization and failure to recover them in time to prevent core damage. If injection systems are recovered even after core damage, reactor vessel failure can be averted if injection is restored within two hours for high pressure sequences. However, if the reactor is depressurized, only about 15 minutes are available between core damage and vessel failure, based on MAAP analysis.

Even if injection systems are not recovered before vessel failure, containment failure can still be averted in most cases if injection is restored within thirteen hours (4 hours for SBO as indicated above).

Because of these various times and effects, separate recovery factors are required for the cases in which core damage occurred at high or low pressure and for recovery after vessel failure. In addition, if the recovery of depressurization fails in the Containment Event Trees, low pressure systems are not available at all before vessel failure. However, all systems are potentially available after vessel failure.

4.6.2.4 Failure to Initiate Containment Spray

Since containment spray is manually initiated, an HEP for this event was obtained by the HRA screening method described in section 3.3.3.1.4. A conditional recovery probability of .3 was applied for containment sprays.

4.6.2.5 Failure to Isolate Containment in Case of Station Blackout (SBO)

A review of the containment penetrations which would be expected to be open during normal operation and would not close on loss of power identified only one line which could lead to containment bypass (section 4.1.2.1)

The HEP for manually closing 1FC008 was determined by the methods described in section 3.3.3.1.4. The task is a manual alignment of a system, directed in procedure CPS 4200.01, performed in the Fuel Building, relatively simple, and at least one-half hour is available for the action, yielding a HEP of .4. Estimates of radiation levels in this location, while high, would not preclude access.

4.6.2.6 Failure to Recover Long-Term Containment Heat Removal in 48 Hours

Because no data is available for 48 hour recovery of power or failed equipment, a value for recovery at this point was estimated. By that time, all the resources of the Emergency Response Organization, not only CPS resources, but also state, local, and national agencies, as well as the Institute of Nuclear Power Operations (INPO), General Electric (GE), etc. would be available. Additionally, time would be available to ship any necessary equipment to the site. A failure to recover at this point was estimated to be $1E-3$.

4.6.2.7 Failure to Open ADS Backup Air Bottles Isolation Valve on Loss of Power

The ADS/LLS motor-operated backup air supply isolation valves are opened from the Main Control Room if normal Instrument Air supply to the SRV's is lost. During Station Blackout, power is not available to open the MOV's, and operators must open the valves

manually before the air accumulators are depleted. The HEP for this action is 0.12.

4.6.2.8 Failure to Vent Containment

Venting of containment is one of the methods to control containment pressure. Three separate vent paths were modeled. The HEP for venting of containment is .25. This action is included in the appropriate procedures, but is not sequenced, leaving the timing to the judgement of the individual.

4.6.3 CET Quantification

4.6.3.1 System Survivability

At CPS, the majority of equipment necessary for accident control is located outside the containment boundary, and will not be exposed to the extreme environmental conditions that are expected during a severe accident. The exceptions are identified in section 4.1.2. Plots generated from MAAP runs which describe important environmental parameters for various accident sequences are included as Figures 4.6-1 through 4.6-17. A brief discussion of the availability/survivability of each of these systems follows.

- Inboard Isolation valves - These valves and valve actuators are qualified for accidents under the provisions of 10CFR50.49. However, all of these valves are either in the required position to perform the required safety function or move to the required position early in an event (except during an SBO), and are expected to successfully complete their required safety function before any potential degradation occurs. The valve actuators are qualified in CPS EQ Binder EQ-CL027 for 340°F, 100% Relative Humidity and 2×10^8 RADS.

- ADS Safety/Relief Valves - System/containment conditions up to the point at which SRV's are no longer required (vessel failure) are below the accident conditions for which the SRV's have been qualified.

- Combustible Gas Control and Associated Components - The Drywell and Containment Mixing Compressors were not modeled because of limited capacity and are not discussed in this section. However, the Vacuum Breakers must be addressed because they provide a path directly bypassing the Suppression Pool. The Vacuum Breaker elastomer seals are qualified in EQ Binder MEQ-CL096 to 500°F for 65 hours. Under the severe conditions in the drywell, the inboard (drywell side) Vacuum Breaker seal is expected to fail early and the outboard (containment side) at some time later. Degradation of the inboard vacuum breaker seals is caused by direct contact with the drywell atmosphere. Initially, heat transfer to the outboard seal material would be exclusively by conduction through the metallic parts of the vacuum breaker penetration. Even after failure of the inboard seal, convective heat transfer to the outboard seal is expected to be small resulting in a significantly longer life for this seal. Seal failure and suppression pool bypass are assumed after drywell temperature reaches 700°F.

The Hydrogen Igniters are qualified in EQ Binder EQ-CL091. They were tested in 100% steam at 330°F for 3 hours, plus 300°F for 3 hours, plus 250°F for 7 days. Therefore the igniters located in the wetwell are expected to survive under all accident scenarios.

- Suppression Pool and Suppression Pool Makeup - The suppression pool make up system was not modeled, and no credit was taken for operability. The 24 inch motor operated valves for Emergency Makeup are qualified for the

same environmental conditions identified earlier for inboard isolation valves. The suppression pool is anticipated to reach saturation temperature during certain accident sequences. Saturation conditions in the suppression pool do not affect the ability of the pumps drawing suction from the pool since all such pumps are designed to pump saturated mixtures (section 3.1.2.3).

Electrical/Mechanical Penetrations - Other than the vacuum breakers discussed earlier, the vulnerable parts of drywell and containment penetrations are the elastomers used for sealing. Penetration Thermal Attack is described in detail in section 4.4.4 of this report. Summarizing the data in that section, drywell penetrations are expected to survive for > 2 weeks at 700°F. Containment penetrations are not expected to fail due to temperature, humidity, and radiation. EQ Binders EQ-CL037, 038 and 039 qualify the penetration seals at 253.5°F, 100% Relative Humidity, 20 psi pressure, and 2.2×10^8 RADs for a 40 year service life.

Containment Vent System - The only parts of the Containment Vent System impacted by severe accident conditions are motor-operated valves. The valves are qualified for the same environmental conditions identified earlier for inboard isolation valves. Venting via the Spent Fuel Pool, using RHR Containment Spray Spargers is through normally closed MOV 1E12F028A. If containment temperature exceeds 340°F, this valve may fail to open on demand, rendering this vent path inoperable. The other two vent paths utilize valves that are normally open, or air operated valves that fail open, and would not impact the capability to vent during extreme environmental conditions.

Containment/Drywell Ventilation Systems - The Containment HVAC System (VR), Drywell Purge System (VQ), and Drywell Cooling System (VP) are not required or designed to operate

under severe accident conditions with the exception of their containment isolation valves. The isolation valves are addressed previously in this section.

Instrumentation Required for Recoveries - Due to the nature of the recoveries the number of instruments required to perform these actions is very limited. This required instrumentation includes RPV Level instruments, RPV pressure instruments, containment pressure instruments, containment hydrogen monitors, suppression pool level and temperature and containment isolation valve position indication. These instruments are all qualified to the requirements of 10CFR50.49, i.e., to perform their respective function during the most severe design basis accident. Based on the timing and containment conditions of the non-truncated level 2 sequences, this instrumentation would be available when required for the respective recovery.

4.6.3.2 Interfacing System LOCA (ISLOCA)

An ISLOCA is not regarded as a significant release mode for CPS. Due to the low frequency of occurrence and available recovery actions, all sequences involving an ISLOCA truncated out in the level 1 analysis (Section 3.1.2.2 and Fig. 3.1-12 for ISLOCA Event Tree).

4.6.3.3 Phenomenological Uncertainties

Section 4.4 discussed treatment of some phenomenological issues for the CPS Containment Analysis. The reported containment results are based on these evaluations. Additional analysis was done to evaluate different assumptions or conditions. Special attention was applied to developing insights into the attributes that affect the estimation of the low containment failure rate. Many MAAP runs were performed with varying parameters in order to determine sensitivity of modeling CPS containment performance to

these various parameters. Cases for MAAP evaluation were based on the EPRI "Recommended Sensitivity Analysis for an IPE using MAAP 3.0B" as well as cases that appeared of concern to the analysis team, such as expected containment failure pressure.

4.6.3.3.1 Hydrogen Sensitivity to Channel Blockage

MAAP is capable of modeling fuel channel blockage by the molten core material, thus preventing further flow in the blocked channels. Several MAAP runs were performed using a localized fuel coolant flow blockage option. The output is consistent with the result expected from the occurrence of local blockage. RPV failure occurs slightly sooner than the unblocked condition which is consistent with the reduction in steam cooling available in the core due to blockage (Note: the non-block option was used for all standard level 2 runs).

Peak drywell temperatures are higher in the blockage case since the vessel fails earlier and therefore more decay heat is retained in the drywell. Hydrogen production is much higher in the no blockage case due to the enhanced contact of Zircaloy and water. This comparison shows that the no blockage model which was used for the basic level 2 analysis is conservative since, for most sequences, more than twice the mass of hydrogen is generated than in the blockage case. For large break LOCAs, use of the blockage model has no material effect on hydrogen production. This result is due to the rapid loss of vessel inventory through the break which sharply limits the amount of hydrogen generated by the Zr metal-water reaction. The small difference in RPV failure time is consistent with the reduction in boiling and inventory loss that would be anticipated with certain core flow channels blocked.

4.6.3.3.2 Source Term Sensitivity to Containment Failure (Vent) Size

Two MAAP runs were performed using containment failure/vent areas differing from the initially assumed area of 0.1963 ft². One run assumed a failure area of 1.0 ft² and the second used a value of 0.1 ft². Venting in all runs was modeled to occur at the start of the run. Vessel failure and suppression pool bypass timings were essentially identical in all runs. The output from these MAAP runs showed no significant difference in the release source term by having a failure area larger than the default area. The source term calculated for the 1.0 ft² area was actually slightly smaller than the base case. Reduction of the vent size did, however, reduce the resultant source by slightly less than an order of magnitude. The 0.1 ft² failure run was reperformed over a longer time interval to determine if the source term would eventually reach approximately the same magnitude as the larger vent runs. A time frame of 72 hours was used and it was noted that while the magnitude of the release was somewhat higher than the 48 hour run, it was still significantly less than the larger containment vent size runs.

4.6.3.3.3 Effect on Containment Performance if In-vessel Recovery Fails

Two MAAP runs were performed to examine the effect on the containment if in-vessel recovery were unsuccessful. The first differed from the second only in the time at which RPV injection was recovered. The first run initiated RPV injection at 180 minutes as opposed to the 72.2 minutes used in the second run.

The results of these runs show that while failure to recover in-vessel did have an effect, it did not pose any significant additional risk to containment integrity. Hydrogen generation is only slightly higher than the recovery in-vessel case and the

peak containment pressure of 28 psia is still far below the containment failure pressure.

4.6.3.3.4 Effect of Using Higher (than CRD) Capacity Recovery Systems

In order to limit the number of MAAP runs required, but yet provide a bounding analysis, CRD, alone, was used as the post accident injection source for all base case analyses.

Two MAAP runs were performed to analyze the effect of using a higher capacity injection system than CRD. The first models a high pressure core damage sequence using HPCS as the recovered injection system. The second is a large LOCA sequence (low pressure) using HPCS as the recovered injection system.

Use of HPCS versus CRD for those sequences most strongly affected hydrogen generation. Significantly less hydrogen is generated using HPCS due to the much more rapid quenching of the fuel. This behavior is consistent with the fuel peak and average fuel temperature plots for the runs which show fuel temperatures reduced to approximately 500°F within a few minutes of HPCS initiation. Using the CRD system, fuel temperatures do not decrease to 500°F for approximately 7 hours following CRD initiation.

4.6.3.3.5 Effect of Varying LOCA Size in Class IIIC Sequences

Two MAAP runs were performed to model large break LOCAs with varying break sizes. The base case large break LOCA utilized a break size equivalent to a shear break of a 18.155 inch I.D. pipe (Reactor Recirculation Pump Suction line). The first run specified a break size equivalent to a 24 inch I.D. pipe and the second run specified a break size equivalent to a 10 inch I.D. pipe.

A review of these runs shows that the core and containment behavior is relatively insensitive to the size of the LOCA in the large break range. No significant differences were noted for the parameters between the runs.

4.6.3.3.6 Effect On Source Term of Leak Before Break

A MAAP run was performed to determine the effect on the release source term for the containment leaking before gross failure. The run utilized a containment failure size of .054 ft² to model containment leakage as compared to a sudden failure size of 0.1 ft². Vessel failure and suppression pool timings were essentially the same in both runs. The leak before break scenario did, however, result in a significantly smaller source term than the base case over the period of analysis.

4.6.3.3.7 Effect of Degree of Revaporization on the Source Term

A MAAP run was performed to determine the effect of reducing the revaporization vapor pressure multiplier on the resultant source term. A SBO sequence with the RPV failing at high pressure was chosen for this run.

Analysis of the fission product release shows that reduction of the revaporization vapor pressure multiplier by a factor of 10 resulted in a reduction in the radionuclide release by approximately a factor of 3. Level 2 analysis runs using the default revaporization vapor pressure multiplier are conservatively modeled in regards to revaporization.

4.6.3.3.8 Effect of Core Melt Progression on Revaporization/ Source Term

A significant factor affecting primary system temperature and the degree of revaporization is the mass of fuel retained within the original core boundaries for an extended length of time. MAAP

predicts that a relatively large mass of fuel slumps to the lower plenum with a drawn out melt of the remaining core material. To analyze the effect of the remaining core material not remaining within the core after core slump, a MAAP run was performed to "dump" the remainder of the core material after 80% of the core mass is in the lower plenum.

Review of these results showed a reduction in the resultant source term by a factor of roughly 2 to 10. Additionally, significantly higher drywell temperatures (1421°F vs 1139°F) were generated in the core dump scenario.

4.6.3.3.9 Effect of Debris Coolability on Containment Performance

To analyze the effect of the degree of core debris coolability on containment performance, two MAAP runs were performed utilizing different critical heat flux parameter (FCHF) values. (FCHF is the critical heat flux parameter used in MAAP to calculate the heat transfer between debris and water) The first was performed with FCHF reduced to 0.10 and the second was performed with FCHF set to 0.02 to model an uncoolable core debris configuration. The original base run used an FCHF value of 0.14. All three of these base runs had temperature spikes in excess of 700°F at vessel failure but are not classified as suppression pool bypass (Penetration Thermal Attack) because of the extremely short time that the drywell gass temperature remained above 700°F

Comparison of the first run, with FCHF at 0.10 with the base case showed the results of the two runs were nearly identical. Correspondingly, it can be seen that moderate reductions in the critical heat flux parameter have a miniscule effect on containment performance. Analysis of the run with FCHF set to 0.02 (uncoolable case) showed a significant increase in hydrogen generation. Additionally, drywell gas temperature was slightly higher (300°F vs. 280°F) and containment pressure was significantly higher (31 psig vs. 19.5 psig) than the base case

at the same point in time. While the uncoolable debris cooling case did result in higher pressure values, the containment structure was still far from the failure threshold pressure (estimated 33 psig vs. 93.8 psig).

4.6.3.3.10 Effect of Rapid Steaming Period Following RPV Failure

Following RPV failure, a short period of rapid steaming can occur when molten corium drops into an existing pool of water. To determine the effect on containment pressure and hydrogen ignition (effect of possible steam inerting) from this rapid steaming, a MAAP run was performed with FCHF set to 2.0.

Analysis of this run showed only a limited and insignificant effect on containment performance and hydrogen ignition from rapid steaming following RPV failure.

4.6.3.3.11 Effect of Varying Vent Timing On Release Source Term

To determine the effect on the fission product release of the timing of containment venting, two additional MAAP runs were performed. The first initiated venting at 6 hours and the second initiated venting at 24 hours. These runs were compared against the base case which initiated venting at 13 hours.

Overall, vent timing had only a small and insignificant effect on the fission product release fractions. There appeared to be a small increase in the volatile fractions for later venting times which is assumed to be due to the higher containment (driving) pressure at the time of venting. Non-volatile species appeared to have slightly smaller release fractions for later vent times. This effect is assumed to be mainly a result of the increased time available for the slower reduction mechanisms associated with non-volatile radionuclides.

4.6.3.3.12 Effect of DW Penetration Failure Size On Release Source Term

To determine the effect on the fission product release fraction of the size of the drywell penetration failure, two additional MAAP runs were performed. One run modeled the drywell penetration failure area at an initial 0.05 ft² and the second run modeled the failure area initially at 1.5 ft². The base case utilized an initial penetration failure size of 0.533 ft² with an additional failure area of 0.533 ft² added at both 800°F and 900°F (Note: the failure area of 0.533 ft² was based on a calculation of the area required to sustain choke flow from the drywell to containment). The two additional runs increased the failure size proportionally at 800°F and 900°F also.

A review of the results shows very little effect on the source term from varying the drywell penetration seal failure area. A slight but insignificant reduction in the release fractions can be seen for the reduced area case while the expanded area case is essentially identical to the base case.

4.6.3.3.13 Effect of Power Recovery Timing On Containment Performance

To analyze the effect of recovering power at some interim time during an SBO several MAAP runs were performed. Since it is assumed that energized equipment could provide an ignition source for hydrogen combustion, this recovery can potentially have a strong effect on containment performance. The MAAP runs and their respective recovery times were as follows:

- TL52-16 - Sequence TL52 with recovery at 16 hrs.
- TL52-24 - Sequence TL52 with recovery at 24 hrs.
- TL52-162 - Sequence TL52 with recovery at 16 hrs and parameter DXHIG set to 0.02
- TL52-242 - Sequence TL52 with recovery at 24 hrs and parameter DXHIG set to 0.02

DXHIG is the MAAP parameter for percent hydrogen concentration at which combustion will occur without energized ignitors.

Analysis of the MAAP runs showed that containment failure from overpressure occurred shortly after power recovery for all cases. The overpressure was a result of hydrogen combustion.

Due to internal MAAP parameters outside of code limits, it was not possible to determine the release source term from the run output. To estimate the release, two additional runs were set up in which power was recovered at 16 and 24 hours but with MAAP parameter DXHIG kept at 0.99 and manual containment venting with a 1 ft² area started at 16 or 24 hours as appropriate. This circumvented the MAAP code problems and allowed a source term to be determined. While this source term has some degree of inaccuracy since the pressure spike associated with containment failure is not present, the long time period following failure should allow these estimation runs to approach the release fractions of the failure runs. Additionally, since the estimation runs resulted in the most severe release class (Class III), use of these estimates for sequence grouping will not result in any error in release category quantification.

Peak drywell temperature and peak containment pressure both increased slightly for the 24 hour restoration sequence. The release fractions for the 16 hour and 24 hour estimation runs are as follows:

<u>Parameter</u>	<u>16 hour</u>	<u>24 hour</u>
Frac. Nobles	0.96	0.91
Frac. CsI/RbI	0.19	0.17
Frac. TeO ₂	1.1E-02	8.0E-03
Frac. CsOH	0.19	0.17
Frac. Te ₂	9.7E-03	2.5E-03
Frac. SrO	3.0E-06	8.5E-07
Frac. MoO ₂	1.2E-05	5.6E-06
Frac. BaO	2.8E-05	2.0E-05

Frac. Lanthanides	1.8E-07	4.6E-08
Frac. CeO ₂	1.3E-06	3.2E-07
Frac. Sb	2.1E-02	6.6E-03
Frac. U/Trans U	5.5E-08	3.0E-08

Additional review of SBO scenarios, sequence modeling and recoveries determined that recovery of power to some equipment in containment during the period of interest (48 hours) was highly likely. This energization of equipment was viewed as having the potential to act as an ignition source. Correspondingly, the base case sequence modeling was changed to include power recovery at some point in the sequence by setting DXHIG to 0.0 at the desired time.

Based on the power recovery runs at 16 and 24 hours, all of which resulted in containment failure, an additional series of scoping runs was performed to determine at what point power could be recovered and still maintain containment integrity. These runs showed that at 4 hours, power could be recovered with concurrent hydrogen ignition without containment overpressure failure occurring from the hydrogen combustion pressure spike.

4.6.3.3.14 Effect of a Stuck Open SRV Concurrent With An SBO

A MAAP run was performed to determine the effect on containment performance of a stuck open SRV occurring during an SBO. A comparison of this run with the base case SBO was performed.

Review of the run results showed that while there is some difference in the time of RPV failure and the peak temperature in the drywell, there is little material difference from a containment performance standpoint. Hydrogen generation is almost identical in both cases and the containment pressures generated in both runs are far below the overpressure failure threshold.

4.6.3.3.15 Effect of a Large Break LOCA With Concurrent SBO

A MAAP run was performed to determine the effect on containment performance of a large LOCA occurring simultaneously with a SBO. A comparison of this run with the base case LOCA event was performed.

Review of these runs shows that the only significant difference between the two cases was in the mass of hydrogen generated. While the LOCA with SBO resulted in substantially more hydrogen present in containment than in the base case, the amount of hydrogen was insufficient to fail the containment as a result of a hydrogen burn.

4.6.3.3.16 Effect of Altering Hydrogen Concentrations In SBO Sequences

Two MAAP runs were performed keeping the value of parameter DXHIG (% H₂) at 0.0 and 0.02. Increasing parameter DXHIG requires a higher hydrogen concentration be present for combustion to occur. Increasing DXHIG to a small positive value simulates the situation in which hydrogen igniters are not energized and the ignition source for hydrogen is energized equipment inside the containment. This treatment differs from the base case in that it used DXHIG set to 0.99 with power to containment off to simulate no ignition source.

Using the default value of DXHIG (0.0) results in a lower peak hydrogen mass in containment. To a large degree this effect is due to a number of smaller hydrogen burns that consume hydrogen. The run which utilized a DXHIG of 0.02 has the effect of delaying hydrogen combustion until higher hydrogen concentrations are reached. Peak hydrogen masses in the different containment areas reflects a smaller amount of hydrogen removed through combustion in this run. Peak containment pressure is higher (58.2 psia vs. 31.8 psia or 29.9 psia) in this sequence than either of the other

noted runs (i.e. DXHIG at 0.0 or .99) due to a larger pressure spike associated with the delayed hydrogen burn (due to the larger DXHIG value), however this increased pressure is still significantly below the containment overpressure failure threshold.

4.6.3.3.17 Effect of a Reduced Containment Overpressure Failure Threshold

A review of the MAAF runs performed for both the level 2 analysis and the previously mentioned sensitivity runs showed that none of the non-failure cases exceeded approximately 59 psia containment pressure. Per the containment overpressurization summary evaluation, the probability of containment failure at this pressure is essentially zero. Correspondingly, further analysis of the overpressurization threshold pressure would provide no additional insight.

4.6.3.3.18 Conclusion

A comparison of worst case scenarios to the base case revealed only one change of assumption (Effect of Debris Coolability) that significantly changed parameters that could challenge containment integrity. However, if this assumption were applied to all CET sequences, it would not significantly increase the containment failure probability.

4.6.3.4 Containment Isolation Failure Analysis

A detailed analysis was performed to determine the conditions and probability that the containment would fail to isolate, given a core melt sequence. The Fault Tree analysis discussed in Section 3.2.1.2.1 included power supply and instrumentation vulnerabilities due to miscalibration, failure to restore from maintenance and common mode failures. Each containment isolation

valve is tested as part of the CPS Technical Specification Surveillance Program at an 18 month frequency, and each valve is included in the CPS Inservice Inspection (ISI) Program. In addition, each valve is included in the Generic Letter 89-10 Program. Each motor-operated valve has a switch located in the Main Control Room that bypasses the motor overload trip function. The switches are in the "normal" (overload bypassed) position unless the valve is being tested.

Only one line at CPS has the potential to provide a containment bypass pathway during a Station Blackout event (valves 1FC007 and 1FC008) (Section 4.1.2.1). These valves are located in a 10 inch schedule 40 pipe line, with an inside diameter of 10.02 inches ($.55 \text{ ft}^2$). Based on this information, the conditional probability of the containment failing to isolate in a SBO was calculated as 0.4 (Section 4.6.2.5).

Table 4.6-1

Time-Phased Power Recovery For Station Blackout Sequence TLU1U3

DESCRIPTION	LEVEL 1 RECOVERY	CONTAINMENT RECOVERY
DG01KA or B fails to run	.2	.34
DG01K fails to run	.1	.34
Common cause failure of any 2 or all 3 Diesel Generators to run	.1	.34
Diesel A, B, or C fuel oil pump fails	.538	.75
Common cause failure of any 2 or all 3 Diesel fuel oil pumps to start	.12	.47
Common cause failure of any 2 or all 3 Diesel fuel oil pumps to run	.34	.75

Table 4.6-2

Time-Phased Power Recovery For Station Blackout Sequence TLU1L4DG1DG2

DESCRIPTION	LEVEL 1 RECOVERY		CONTAINMENT RECOVERY	
	1 HOUR	4 HOUR	1 HOUR	4 HOUR
DG01KA, B, or C fails to run	.14	.191	.52	.87
Common cause failure of any 2 or all 3 Diesel Generators to run	.03	.09	.52	.87
Diesel A, B, or C fuel oil pump fails	.54	.54	.81	.84
Common cause failure of any 2 or all 3 Diesel fuel oil pumps to start	.02	.19	.42	.52
Common cause failure of any 2 or all 3 Diesel fuel oil pumps to run	.0052	.078	.81	.84

CLASS 1A CET
SEQUENCE 1A54
TYPICAL HIGH PRESSURE RPV FAILURE SEQUENCE
CONTAINMENT PRESSURE

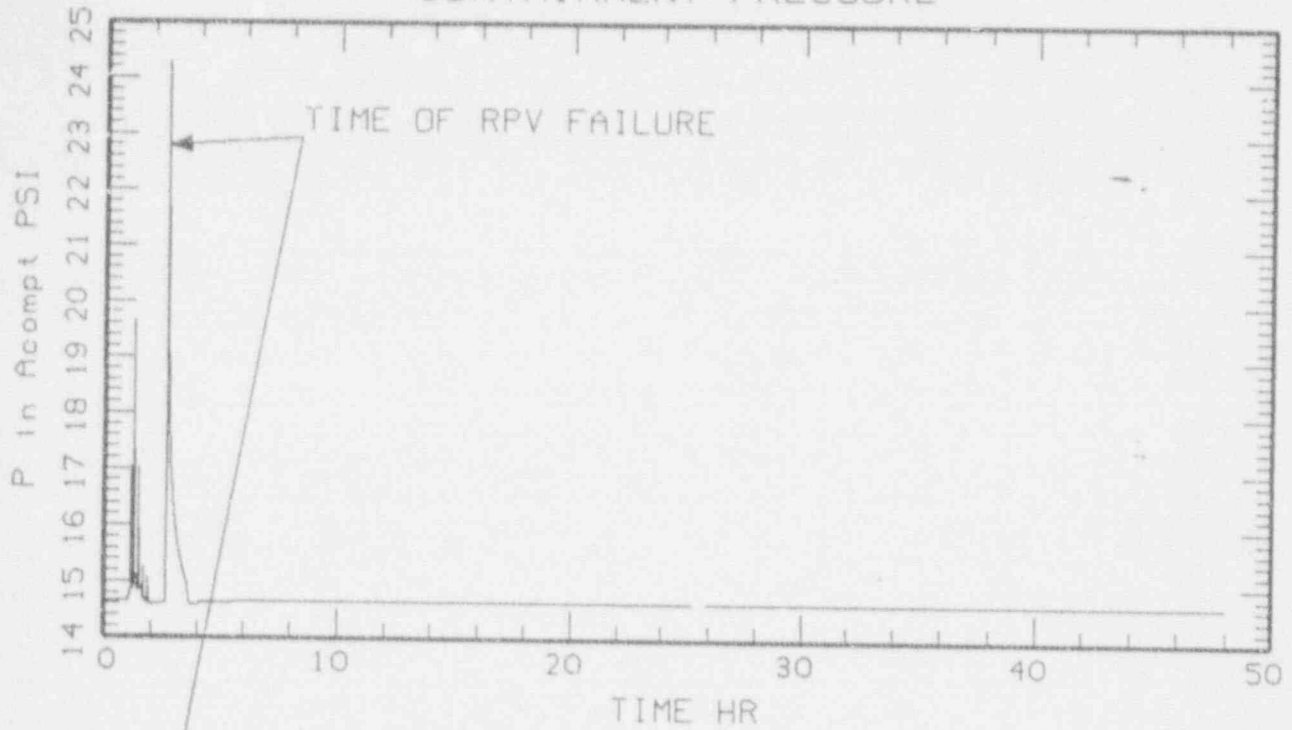

CONTAINMENT TEMPERATURE

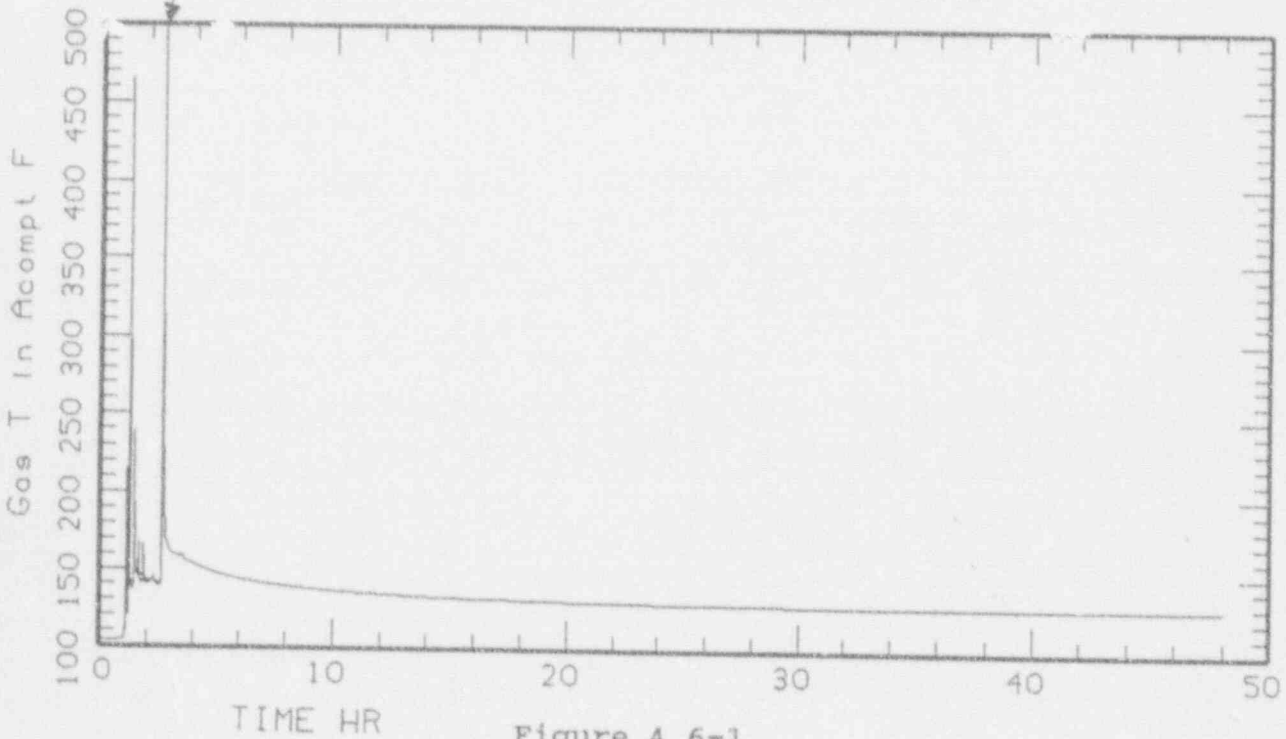

Figure 4.6-1

A Compt - Portion of containment below elevation 828' and above elevation 755'.

CLASS IA CET
SEQUENCE IA54
TYPICAL HIGH PRESSURE RPV FAILURE SEQUENCE

DRYWELL TEMPERATURE

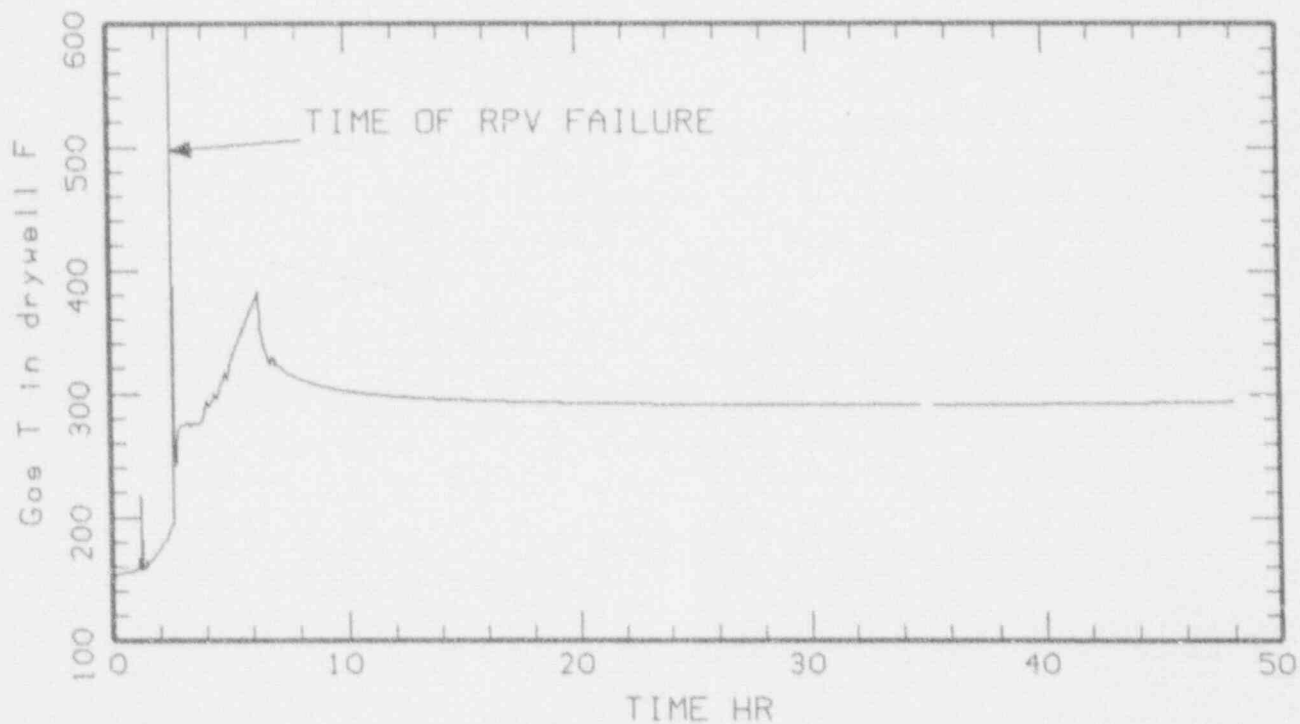

Figure 4.6-2

CLASS IA CET
SEQUENCE 1A54
TYPICAL HIGH PRESSURE RPV FAILURE SEQUENCE

CONTAINMENT HYDROGEN

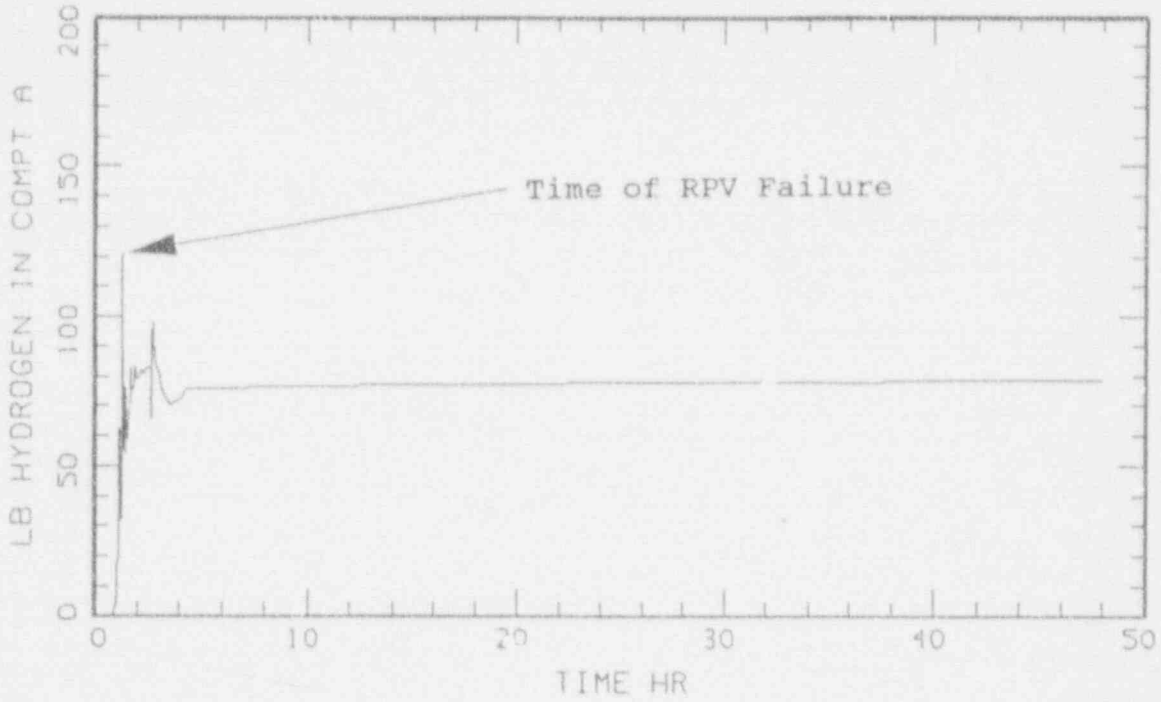
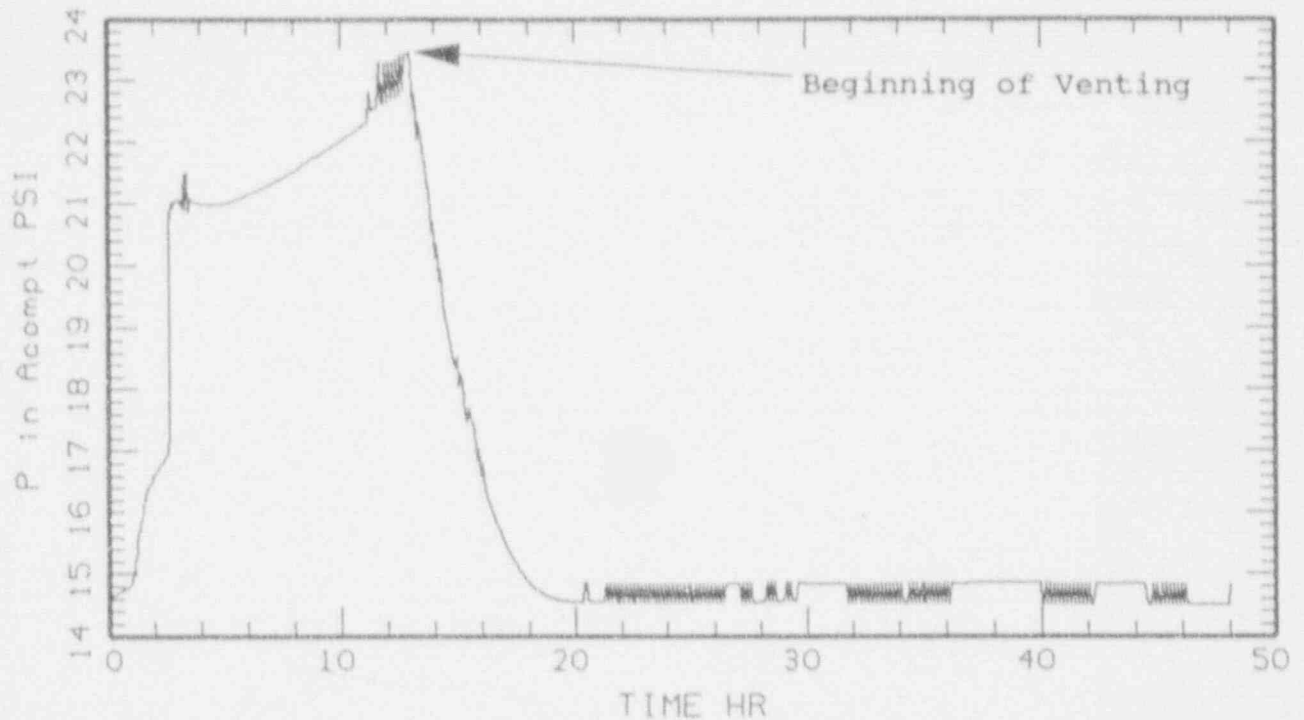

Figure 4.6-3

Compt A - Portion of containment, below elevation 828' and above elevation 755'.

CLASS 1B CET
 SEQUENCE TL51
 TYPICAL STATION BLACK OUT SEQUENCE

CONTAINMENT PRESSURE



CONTAINMENT TEMPERATURE

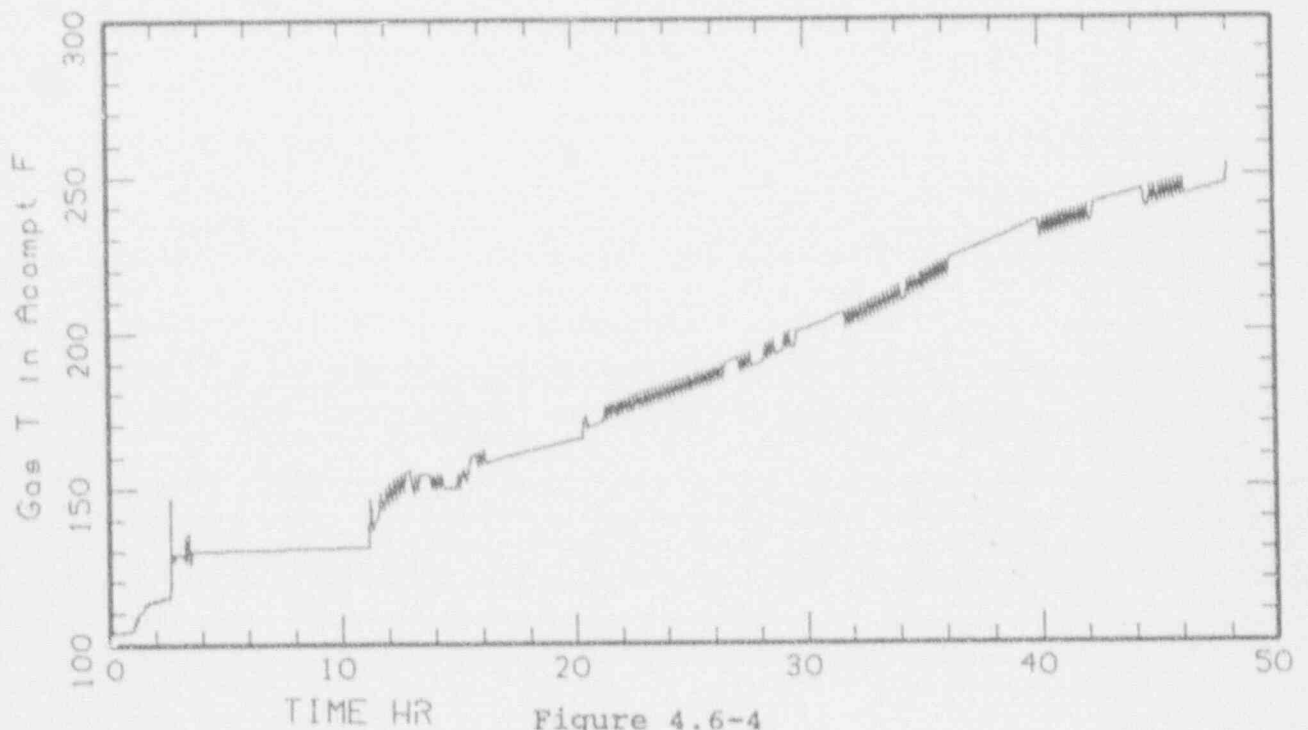
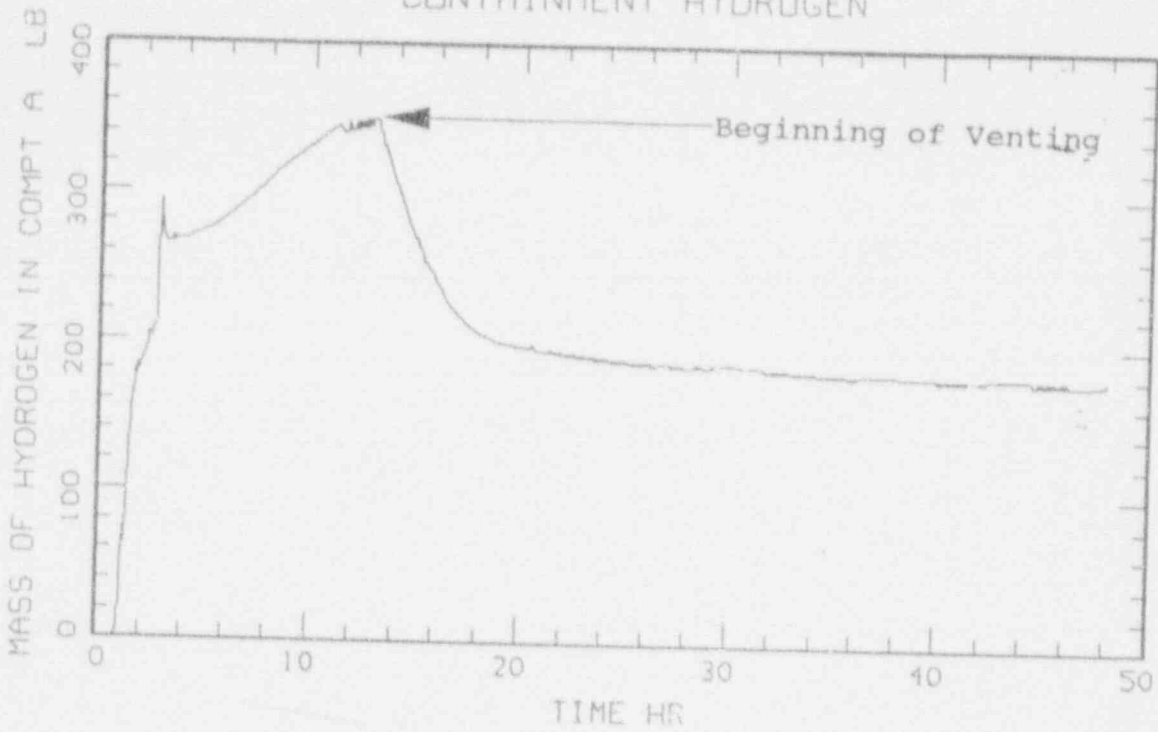

Figure 4.6-4

A compt - Portion of containment below elevation 828' and above elevation 755'.

CLASS 1B CET
 SEQUENCE T151
 TYPICAL STATION BLACK OUT SEQUENCE

CONTAINMENT HYDROGEN



CONTAINMENT HYDROGEN

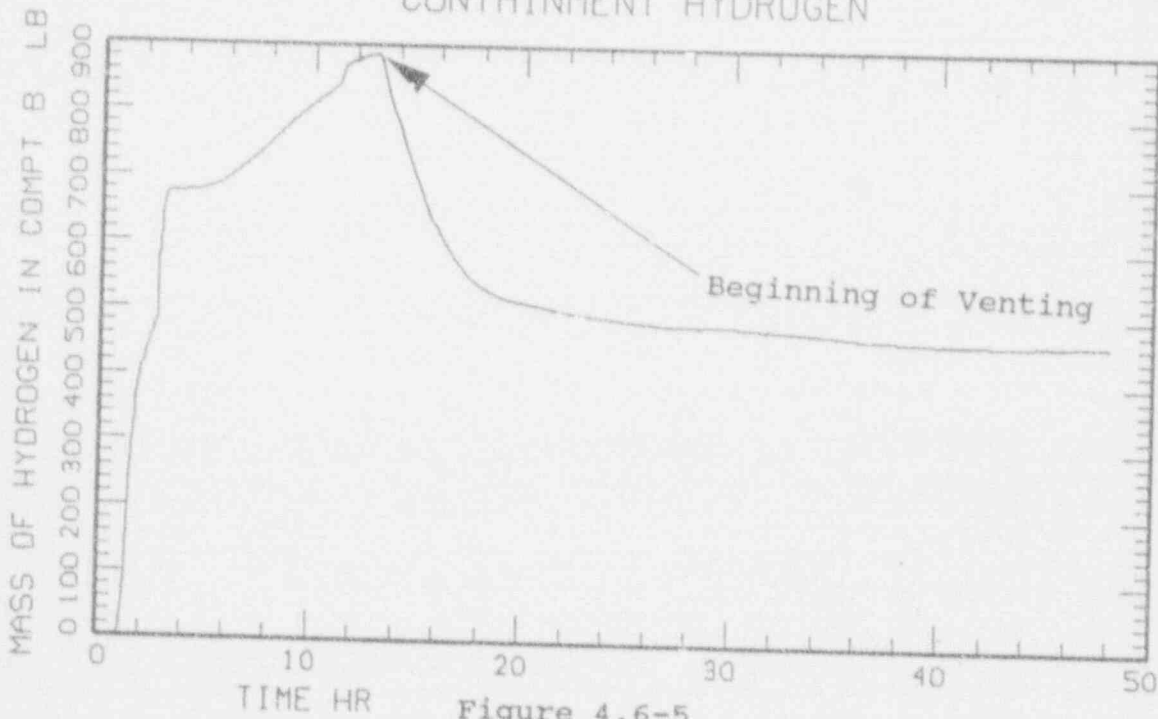

Figure 4.6-5

Compt B - Portion of containment above elevation 828'.
 Compt A - Portion of containment below elevation 828' and above elevation 755'.

CLASS 1B CET
SEQUENCE T1S;
TYPICAL STATION BLACK OUT SEQUENCE

DRYWELL TEMPERATURE

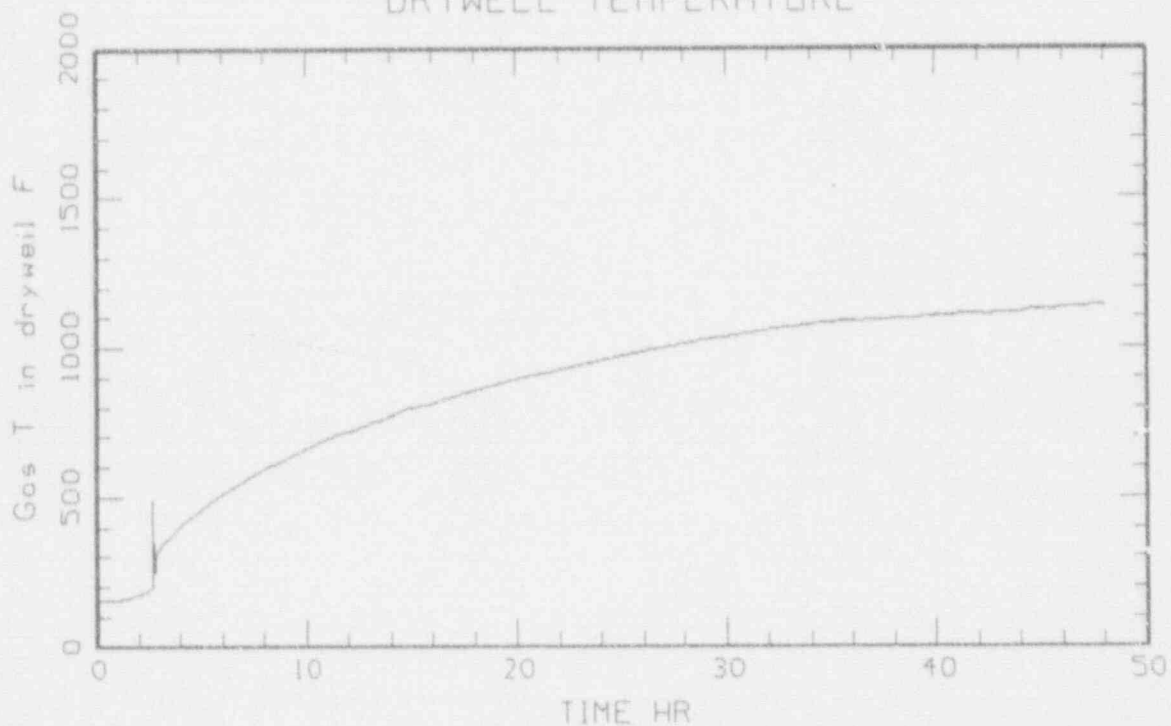
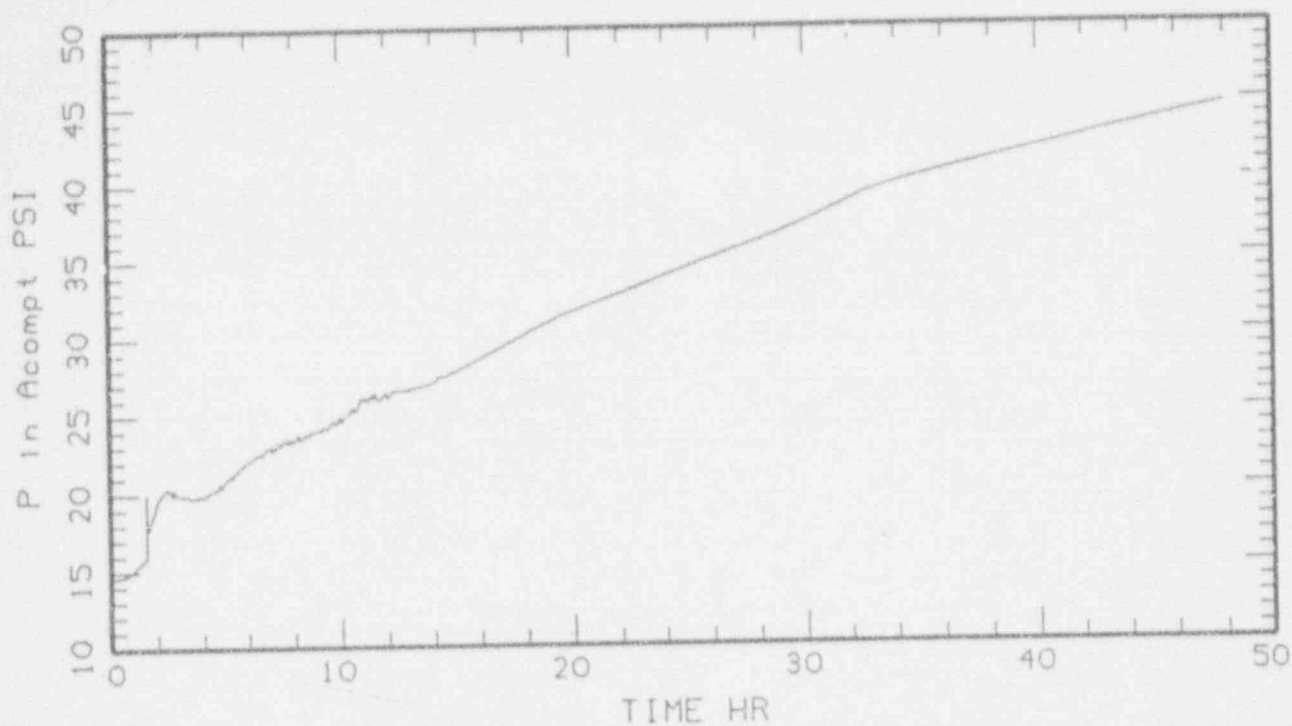

Figure 4.6-6

CLASS 10 CET
SEQUENCE 1047
TYPICAL LOW PRESSURE RPV FAILURE SEQUENCE

CONTAINMENT PRESSURE



CONTAINMENT TEMPERATURE

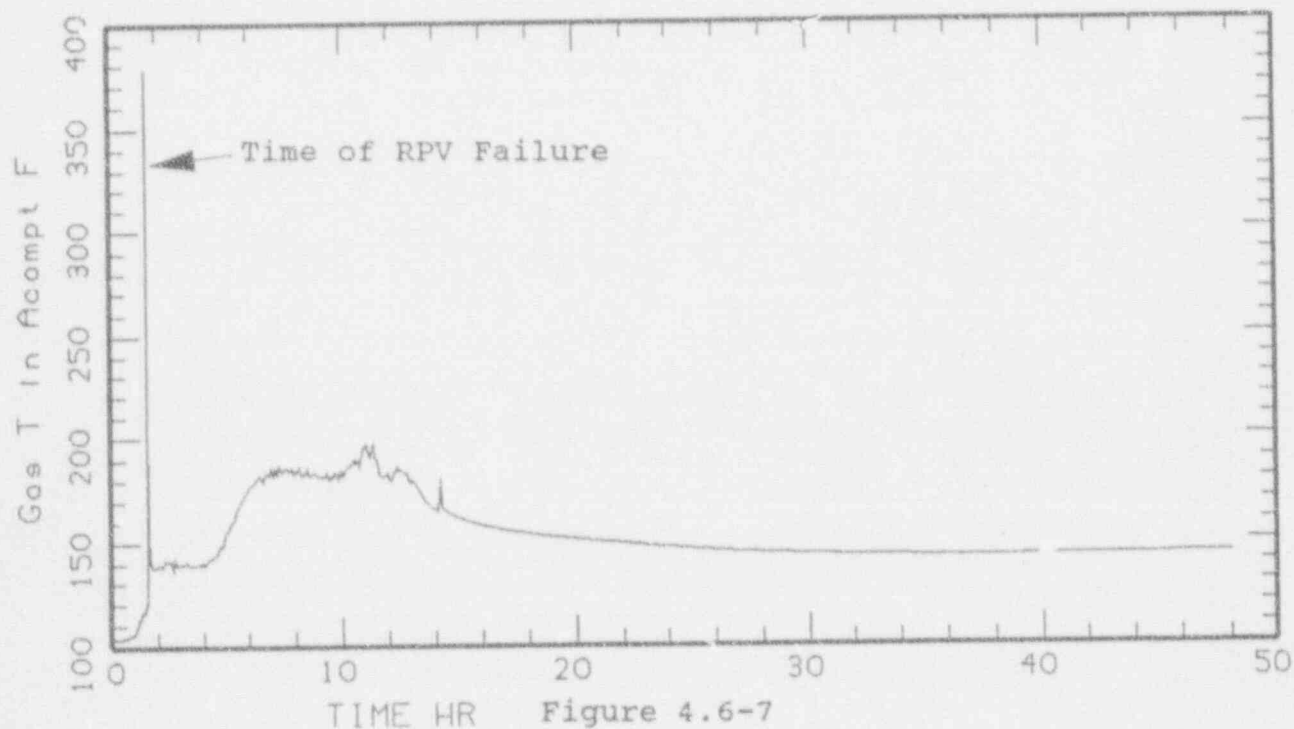

TIME HR Figure 4.6-7

A compt - Portion of containment below elevation 828' and above elevation 755'.

CLASS ID CET
SEQUENCE ID47
TYPICAL LOW PRESSURE RPV FAILURE SEQUENCE

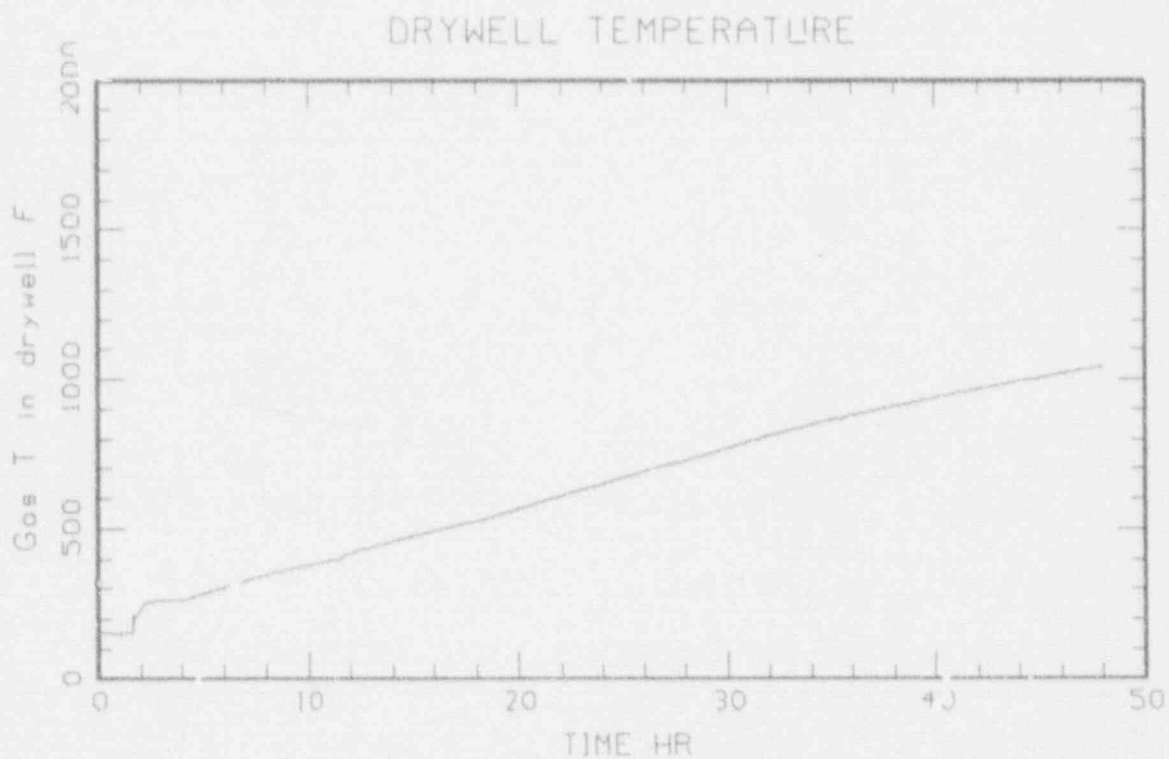

Figure 4.6-8

CLASS ID CET
SEQUENCE ID47
TYPICAL LOW PRESSURE RPV FAILURE SEQUENCE

CONTAINMENT HYDROGEN

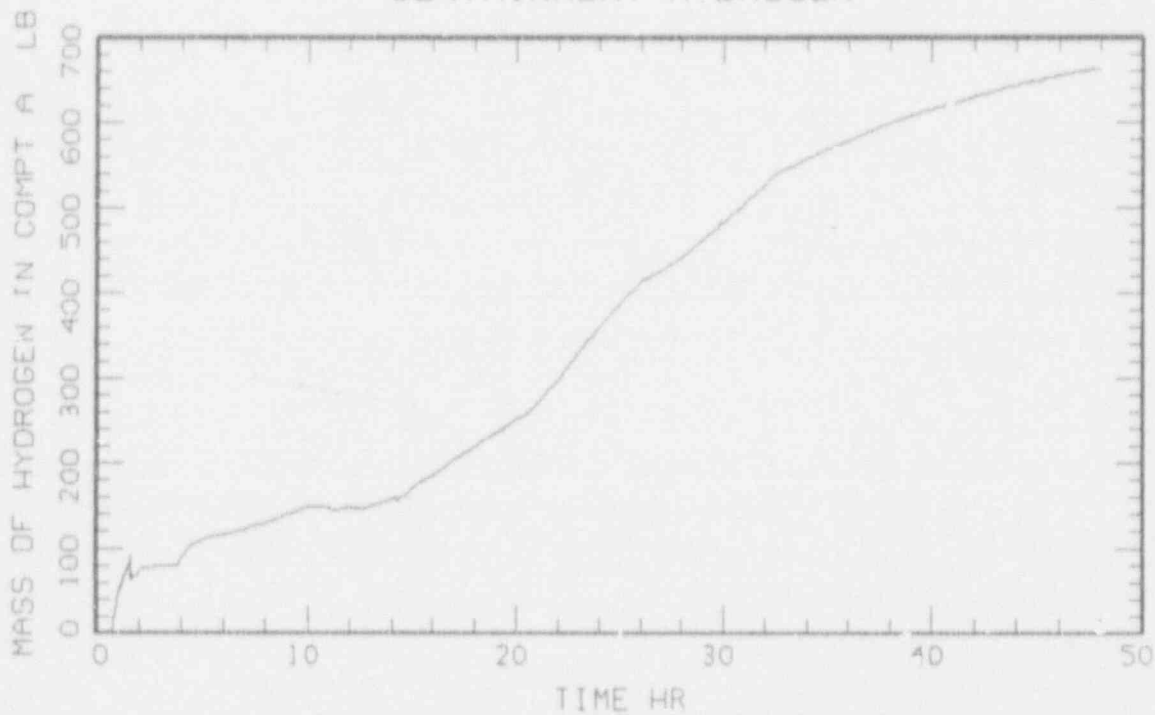
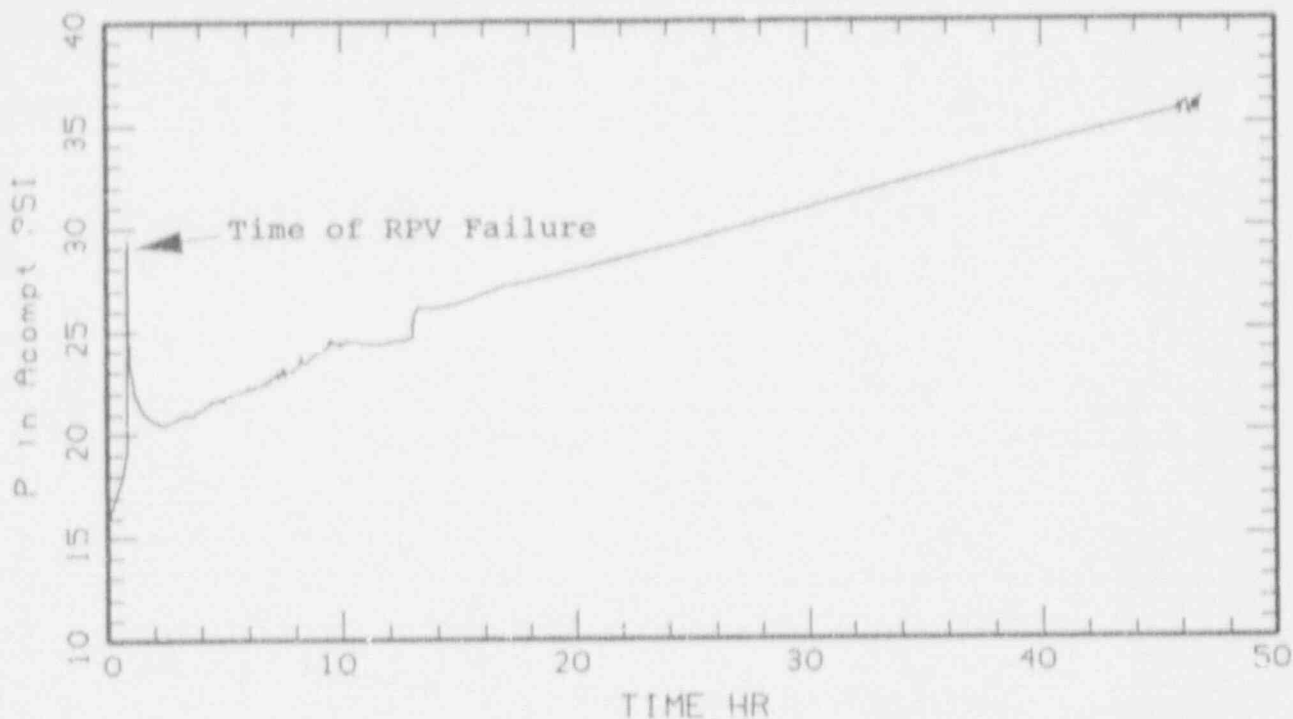

Figure 4.6-9

Compt A - portion of containment below elevation 828' and above elevation 755'.

CONTAINMENT PRESSURE



CONTAINMENT TEMPERATURE

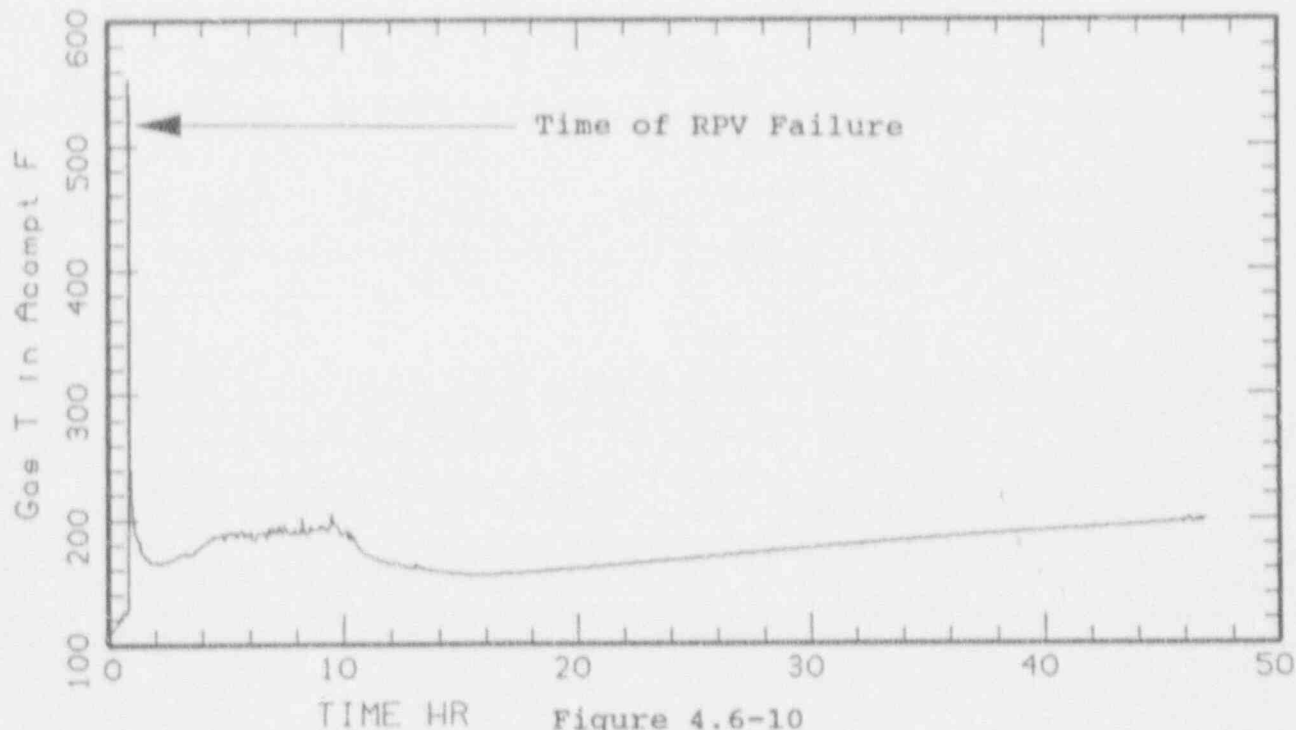

Figure 4.6-10

A compt - Portion of containment below elevation 828' and above elevation 755.

CLASS 3B CET
SEQUENCE LB31
TYPICAL HIGH PRESSURE RPV FAILURE LOCA SEQUENCE

DRYWELL TEMPERATURE

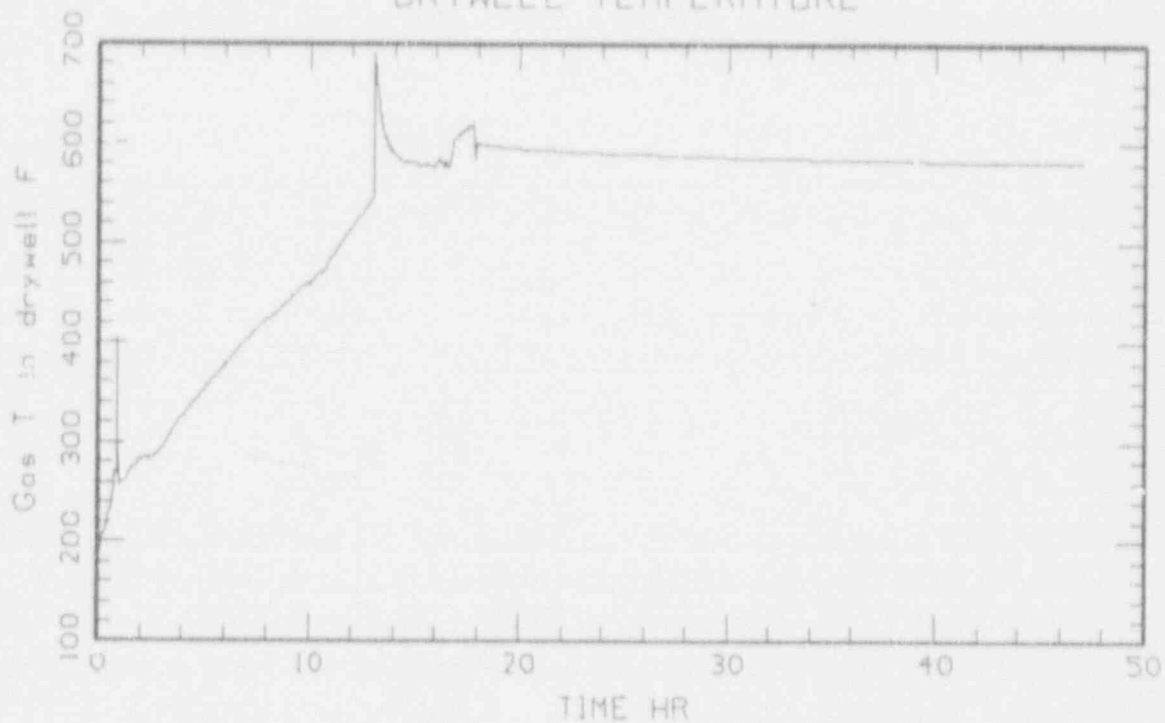

Figure 4.6-11

CLASS 3B CET
SEQUENCE LB31
TYPICAL HIGH PRESSURE RPV FAILURE LOCA SEQUENCE

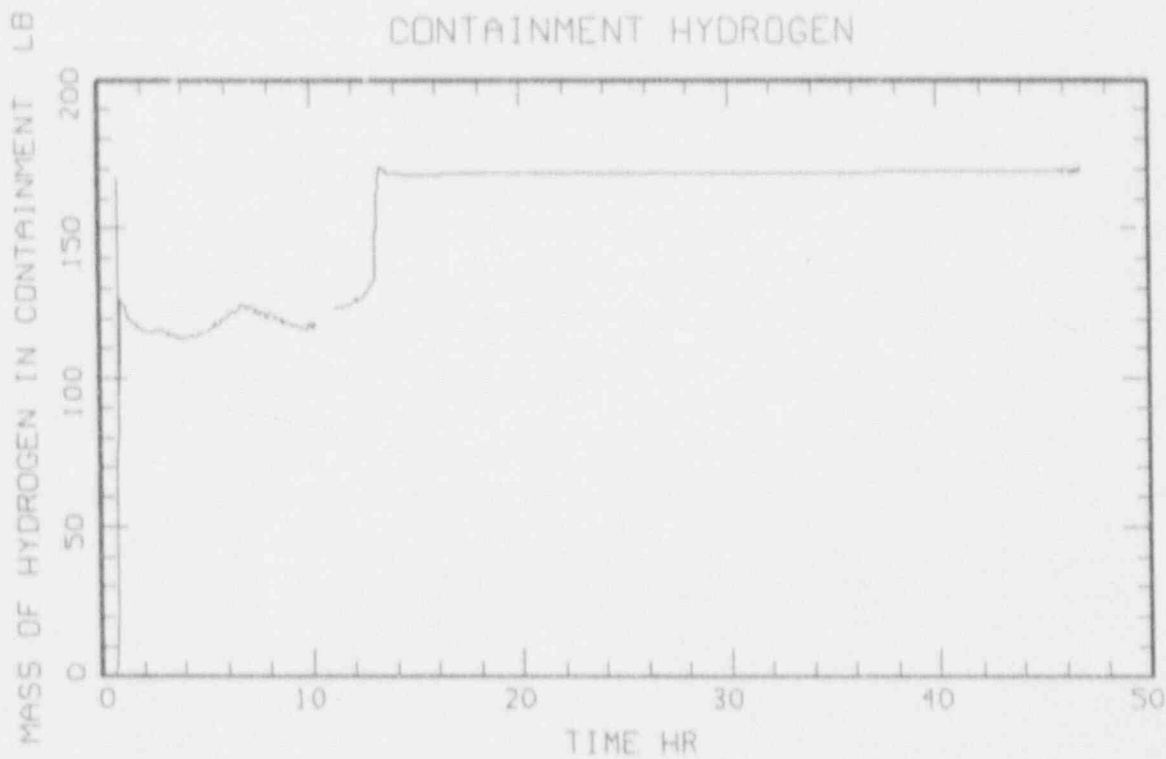
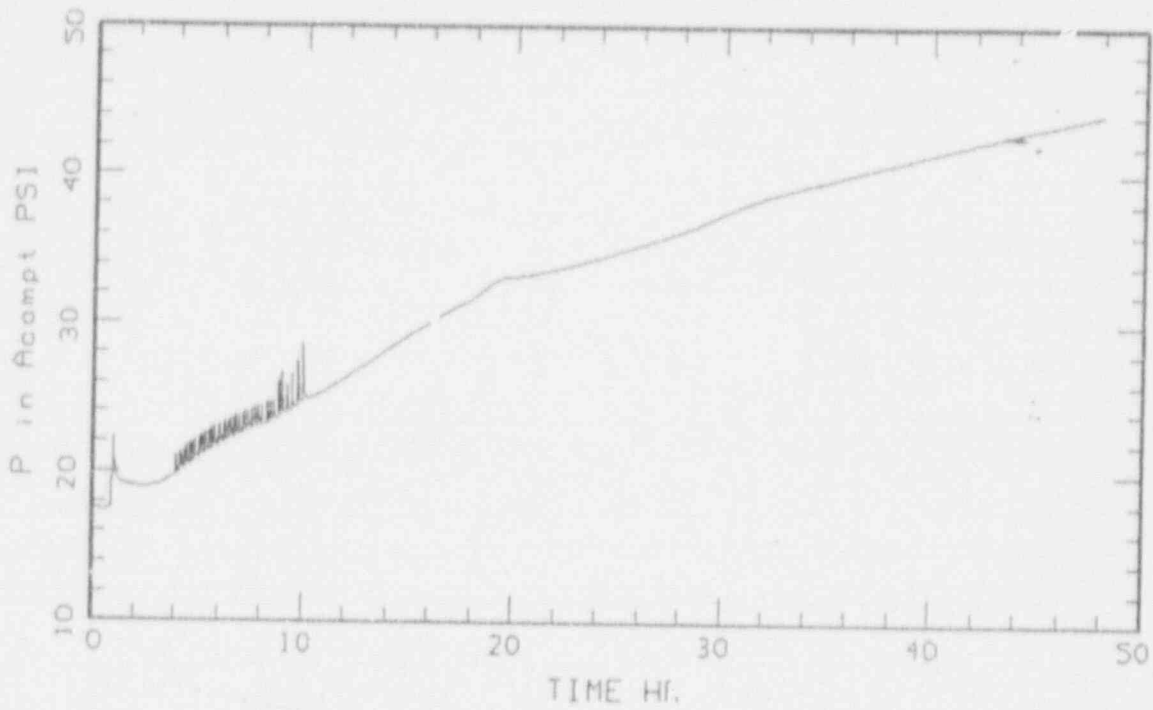

Figure 4.6-12

CLASS 3C CET
SEQUENCE LC42
TYPICAL LOW PRESSURE LOCA SEQUENCE

CONTAINMENT PRESSURE



CONTAINMENT TEMPERATURE

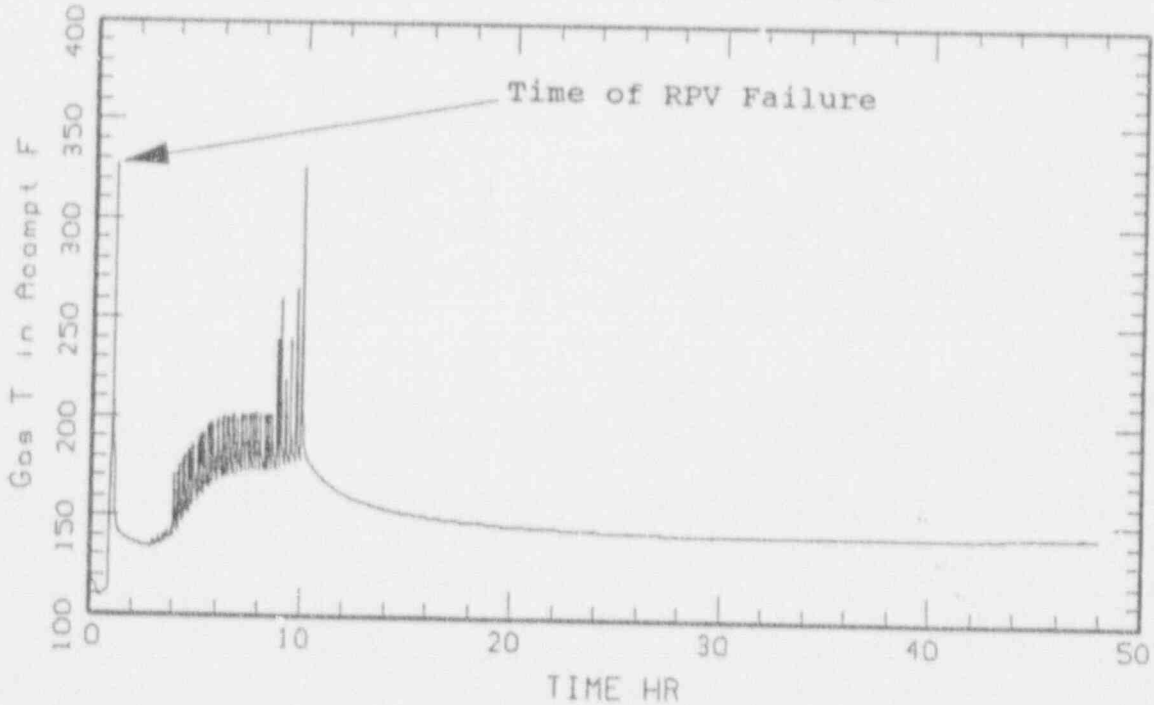

Figure 4.6-13

A compt - Portion of containment below elevation 828' and above elevation 755'.

CLASS 30 CE1
SEQUENCE LC42
TYPICAL LOW PRESSURE LOCA SEQUENCE

DRYWELL TEMPERATURE

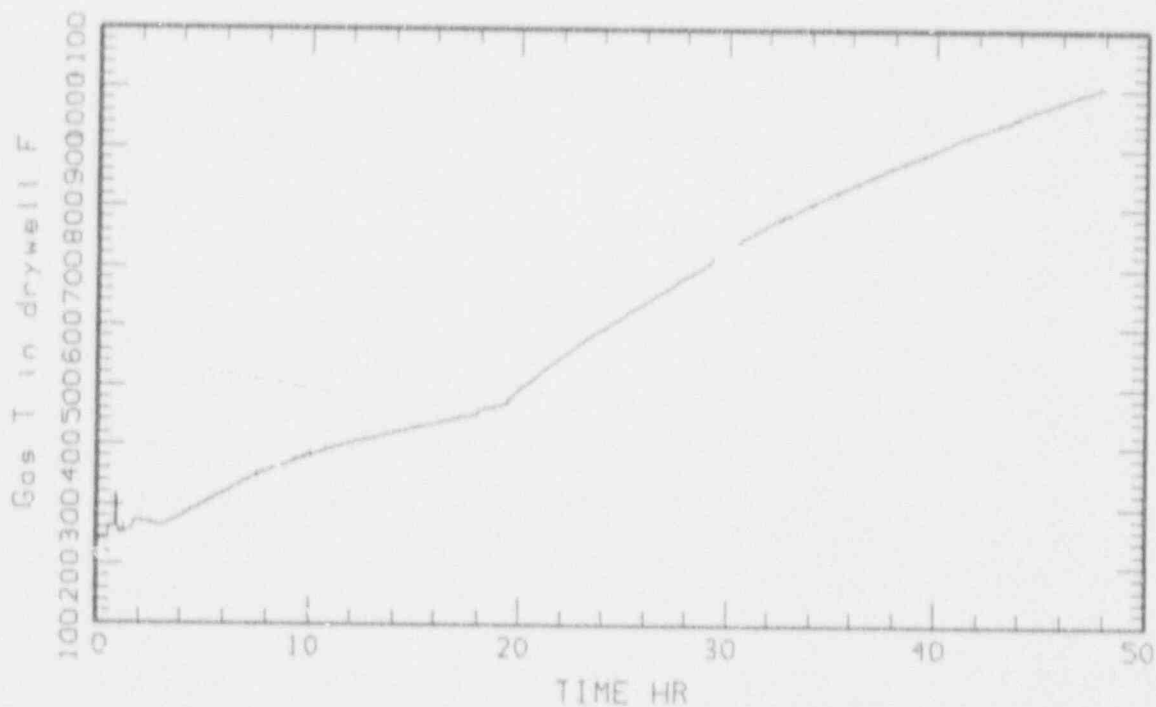

Figure 4.6-14

CLASS 30 CET
SEQUENCE LC42
TYPICAL LOW PRESSURE LOCA SEQUENCE

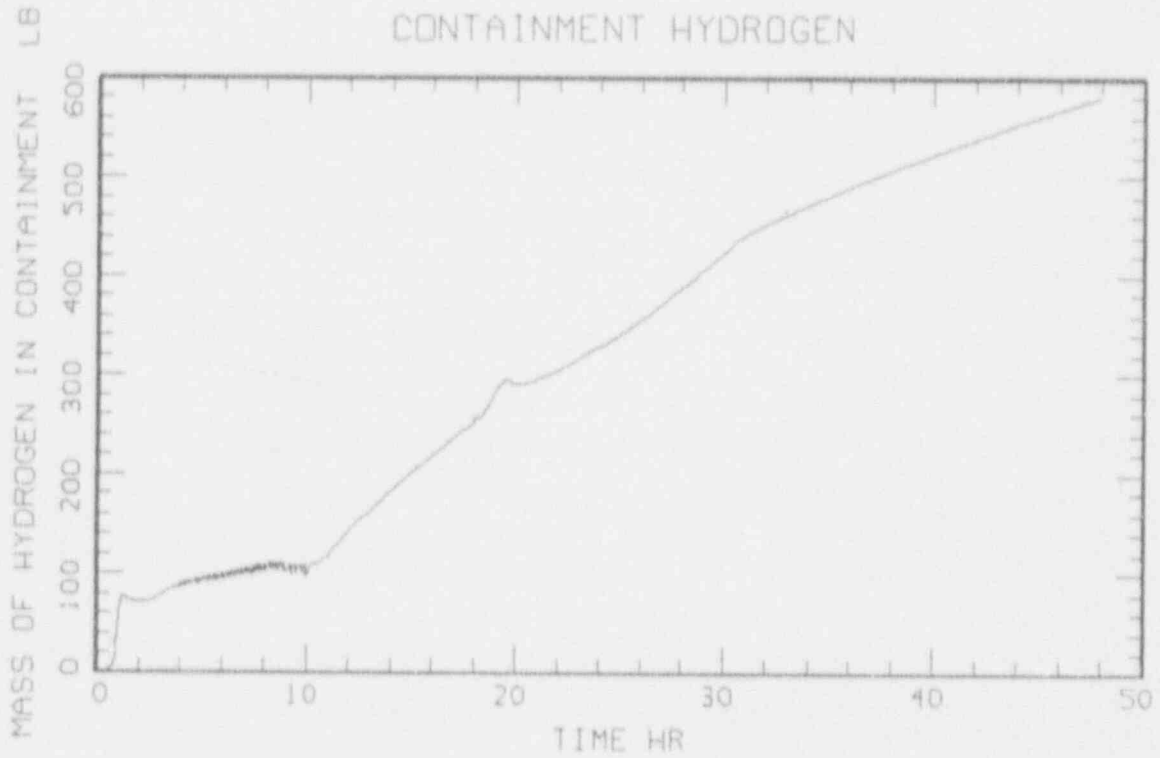
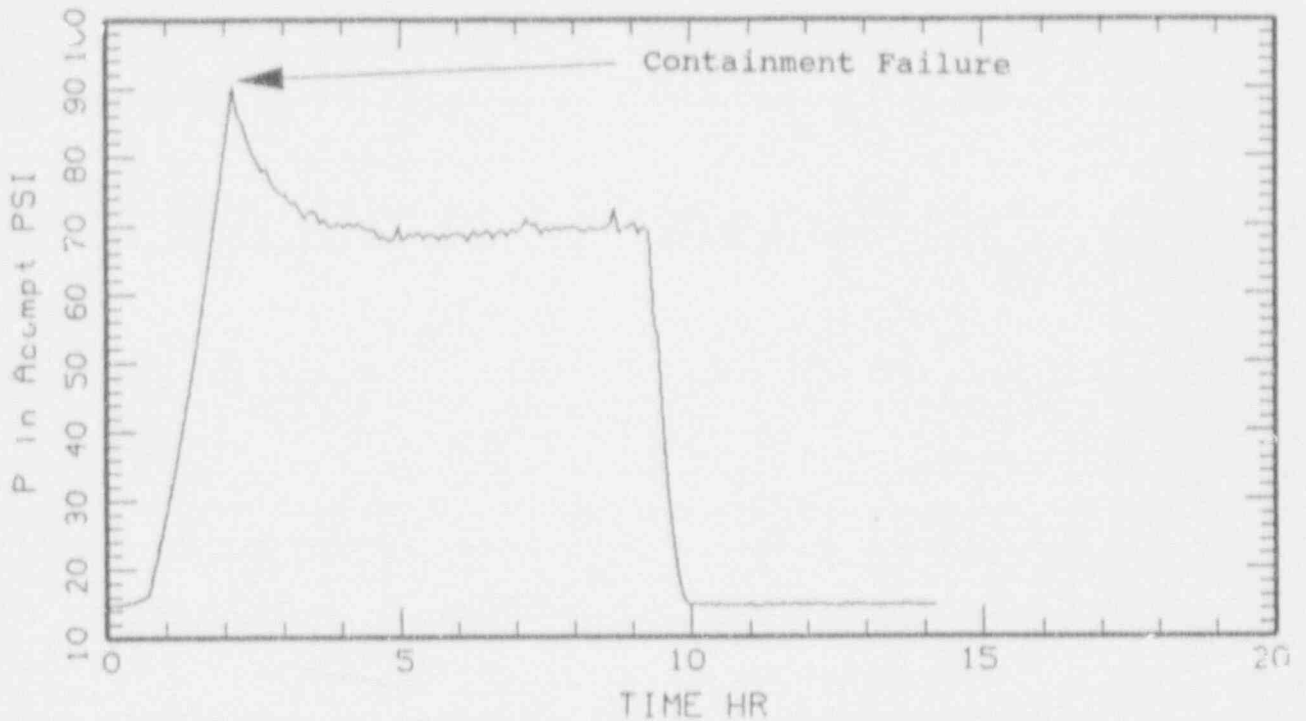

Figure 4.6-15

CLASS IV CET
 SEQUENCE ATO1
 TYPICAL ATWS SEQUENCE

CONTAINMENT PRESSURE



CONTAINMENT TEMPERATURE

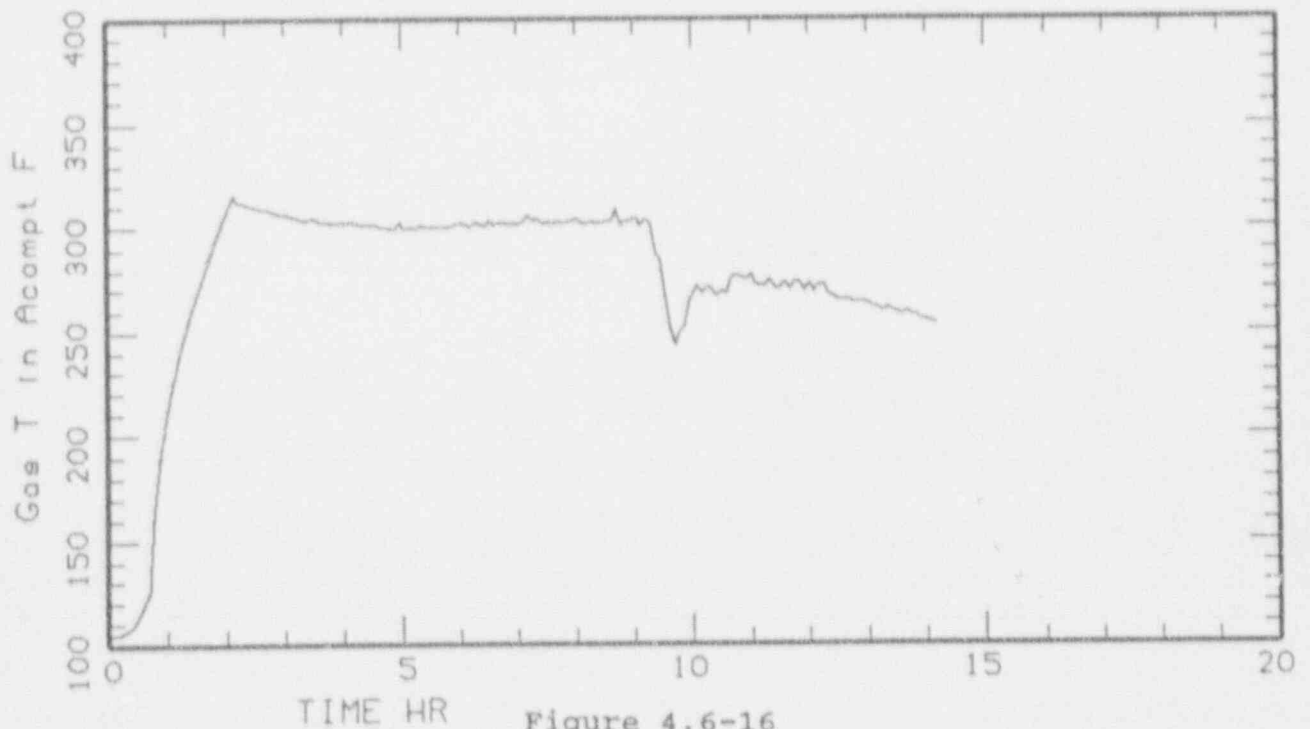

Figure 4.6-16

A compt - Portion of containment below elevation 828' and above elevation 755'.

CLASS IV CET
SEQUENCE ATO1
TYPICAL ATWS SEQUENCE

DRYWELL TEMPERATURE

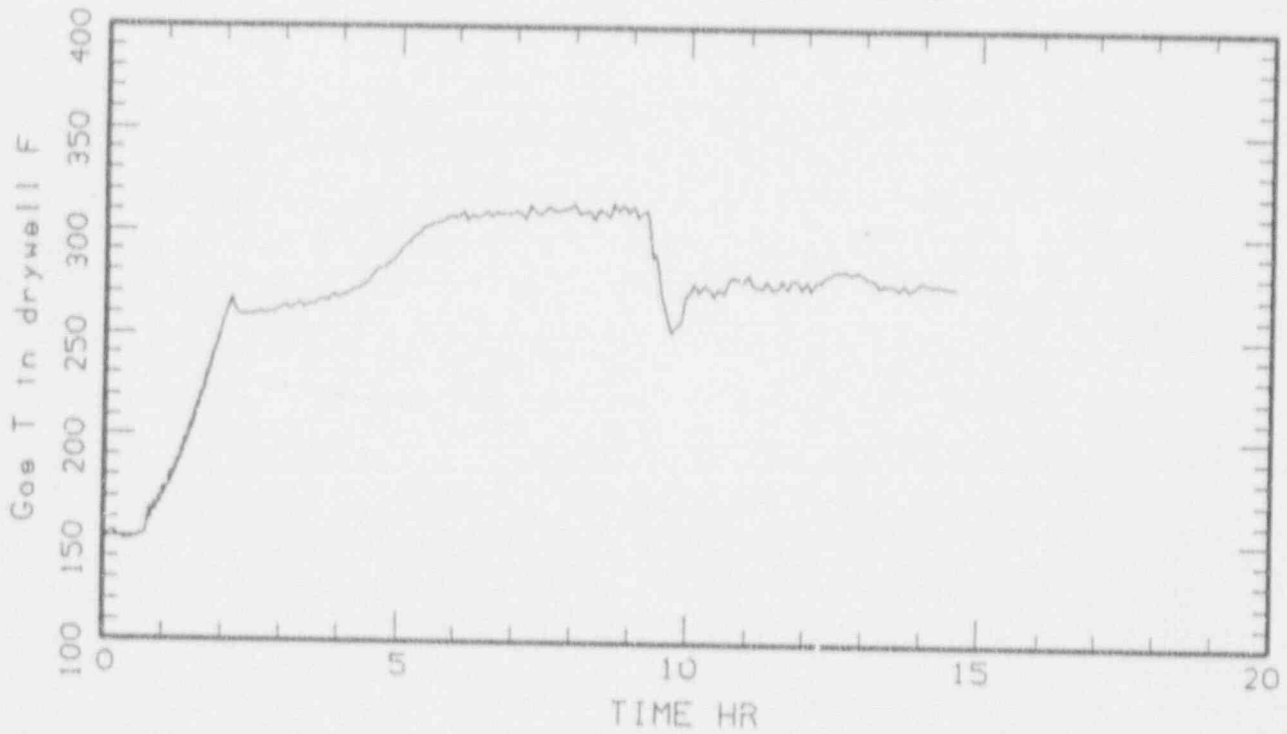

Figure 4.6-17

4.7 Source Term

4.7.1 Introduction

The release mode associated with each level 2 sequence is a description of the performance of various containment structures and systems that can affect the magnitude of a radionuclide release. The following questions regarding status of containment structures and systems determine the release mode:

- Containment building - Is the containment isolated, vented, failed or bypassed? If the containment building is failed, does the failure bypass the suppression pool? If the failure occurs in conjunction with suppression pool bypass, is vessel injection or containment sprays available?
- Release location prior to vessel failure - Is the release occurring in the drywell or the wetwell?
- Size of the containment failure - Does a large or a small containment failure occur? Note: it is assumed that containment failure from ATWS or hydrogen combustion results in a large containment failure. Failure to isolate is a small failure.
- Timing of the containment failure - does containment failure occur before or after vessel failure?

Table 4.3-4 contains a matrix used to assign sequence release modes. Once determined, the sequence release modes provide a general means of categorizing release source terms.

Source term categories are based on the percent of core inventory released to the environment. For additional detail see the discussion in section 4.3.5.

Based on the level 2 quantification results, 20 sequences were identified as significant (i.e. survived truncation at $1E-9$). No significant sequences were identified in the class V (ISLOCA) event tree and no further analysis was performed on this class of events. These 20 sequences were all identified on the CETs, Figures 4.5-1 through 4.5-6. Table 4.7-2 summarizes the containment status and release categories for the 20 significant sequences evaluated.

Figure 4.7-1 graphically shows the Plant Damage States, the Accident Release Modes, and Accident Source Terms for cases in which containment failure occurred.

A review of the source terms resulting from the containment failure sequences shows that the source terms are fairly large (all Class II & III). Determination of these source terms does, however, have a number of conservatisms incorporated. For sequence TL51, venting would be performed using a pathway through the spent fuel pool. The spent fuel pool would have essentially the same effect of scrubbing the volatile and non-volatile fission products as the suppression pool and would significantly reduce the source term. This same effect would be seen for sequence TL54 since the containment isolation failure path in a SBO would also be through the spent fuel pool.

Another conservatism is involved in the modeling of failure of the drywell penetration seals from PTA. This modeling assumed complete failure of both the inner and outer seals when 700°F was reached inside the drywell. Failure of only the inner seal from PTA would significantly reduce the release source term in containment overpressure sequences (TL52, TL53) since less of the volatile fission products would be present in the containment airspace at containment failure.

Table 4.7-1

Source Term Release Data

(Fraction of Inventory Released to Environment)

SEQUENCE	1A01	1A15	1A30	TL01	TL14	TL16	TL51	TL52	TL53	TL54
Plant Damage State	RXXX	RXXX	HXXX	RXXX	HXXX	HXXX	HVBI	NOHI	NOHI	HCIE
Release Mode	A0	A0	A0	A0	A0	A0	D5	D6	D6	A1
RPV Failure Time	N/A	N/A	2.6HR	N/A	2.7HR	2.6HR	2.7HR	2.6HR	2.6HR	2.6HR
CT Failure Time	N/A	N/A	N/A	N/A	N/A	N/A	13HR	4.1HR	4.1HR	0.0HR
					*(VENT)					
NOBLES	0.0	0.0	0.0	0.0	0.0	0.0	0.65	0.91	0.91	0.98
VOLATILES	(Fraction of initial inventory released)									
CsI, RbI	0.0	0.0	0.0	0.0	0.0	0.0	4.2E-2	0.17	0.17	2.1E-1
TeO2	0.0	0.0	0.0	0.0	0.0	0.0	5.9E-3	8.0E-3	8.0E-3	3.9E-3
CsOH	0.0	0.0	0.0	0.0	0.0	0.0	4.3E-2	0.17	0.17	2.1E-1
Te2	0.0	0.0	0.0	0.0	0.0	0.0	8.9E-3	2.5E-3	2.5E-3	2.7E-2
NON-VOLATILES	(Fraction of initial inventory released)									
SrO	0.0	0.0	0.0	0.0	0.0	0.0	2.8E-5	8.5E-7	8.5E-7	6.6E-5
MoO2	0.0	0.0	0.0	0.0	0.0	0.0	1.8E-5	5.6E-6	5.6E-6	1.8E-5
BaO	0.0	0.0	0.0	0.0	0.0	0.0	7.1E-5	2.0E-5	2.0E-5	8.0E-5
Lanthanides	0.0	0.0	0.0	0.0	0.0	0.0	1.8E-7	4.6E-8	4.6E-8	3.1E-7
CeO2	0.0	0.0	0.0	0.0	0.0	0.0	1.4E-5	3.2E-7	3.2E-7	2.6E-5
Sb	0.0	0.0	0.0	0.0	0.0	0.0	2.2E-2	6.6E-3	6.6E-3	5.0E-2
U/Trans-U	0.0	0.0	0.0	0.0	0.0	0.0	2.6E-8	3.0E-8	3.0E-9	7.1E-8
Release Category	NR	NR	NR	NR	NR	NR	II	III	III	III

* TL14 - No release in this sequence. The (vent) at containment failure time indicates venting option was available but not used because containment pressure did not reach venting pressure. No release indicates venting was not used.

Table 4.7-1

Source Term Release Data

(Fraction of Inventory Released to Environment)

SEQUENCE	ID01	ID41	ID47	ID49	LB26	LB31	LC01	LC42	AT01	AT15
Plant Damage State	RXXX	LXXX	LXXX	LXXX	HXXX	HXXX	LXXX	LXXX	ROAE	ROAE
Release Mode	A0	A0	A0	A0	A0	A0	A0	A0	D4	D4
RPV Failure Time	N/A	1.6HR	1.6HR	1.6	0.9HR	0.87HR	0.89HR	0.89HR	N/A	N/A
CT Failure Time	N/A	N/A	N/A	N/A	N/A	N/A	N/A	N/A	2.14HR	2.14HR
NOBLES	0.0	0.0	0.0	0.0	0.0	0.0	0.0	0.0	0.20	0.20
VOLATILES	(fraction of initial inventory released)									
CeI, RbI	0.0	0.0	0.0	0.0	0.0	0.0	0.0	0.0	2.9E-2	>0.1
TeO2	0.0	0.0	0.0	0.0	0.0	0.0	0.0	0.0	<1.0E-3	>0.1
CsOH	0.0	0.0	0.0	0.0	0.0	0.0	0.0	0.0	2.9E-2	>0.1
Te2	0.0	0.0	0.0	0.0	0.0	0.0	0.0	0.0	<1.0E-3	>0.1
NON-VOLATILES	(fraction of initial inventory released)									
SrO	0.0	0.0	0.0	0.0	0.0	0.0	0.0	0.0	2.7E-5	>0.1
MoO2	0.0	0.0	0.0	0.0	0.0	0.0	0.0	0.0	1.4E-3	>0.1
BaO	0.0	0.0	0.0	0.0	0.0	0.0	0.0	0.0	2.4E-4	>0.1
Lanthanides	0.0	0.0	0.0	0.0	0.0	0.0	0.0	0.0	1.3E-7	>0.1
CeO2	0.0	0.0	0.0	0.0	0.0	0.0	0.0	0.0	1.4E-7	>0.1
Sb	0.0	0.0	0.0	0.0	0.0	0.0	0.0	0.0	3.9E-3	>0.1
U/Trans-U		0.0	0.0	0.0	0.0	0.0	0.0	0.0	<1.0E-3	>0.1
Release Category	NR	NR	NR	NR	NR	NR	NR	NR	II	III

Table 4.7-2

Containment Sequence Performance Summary

Number of Sequences Resulting in Each Category

Containment Status

<u>Intact</u>	<u>Fail</u>	<u>Isolation Failure</u>	<u>Vented</u>
14	4	1	1

Release Category

<u>No Release</u>	<u>Class I</u>	<u>Class II</u>	<u>Class III</u>
14	0	2	4

CONTAINMENT FAILURE

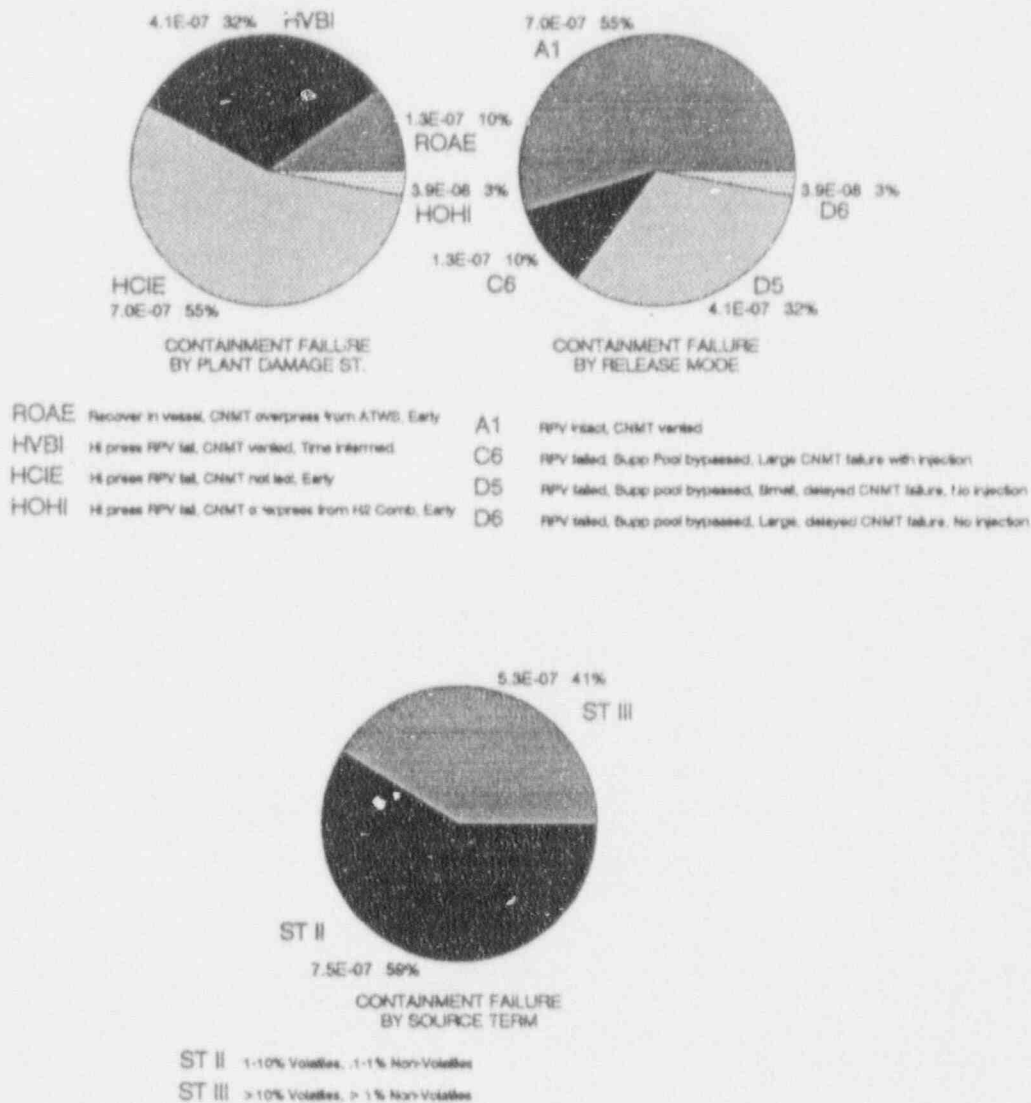

FIGURE 4.7-1

THIS PAGE

INTENTIONALLY

LEFT BLANK

5.0 Utility Participation and Project Reviews

5.1 IPE Program Organization

The Clinton Power Station IPE program was performed and managed by Illinois Power Company. The entire IPE team is located at the plant site and the members have been involved in all aspects of Clinton activities. IP Nuclear Station Engineering is the lead department for the program and all IPE team members are located in this department. Two team members maintain active qualifications for performing shift duties in the main control room, one a Senior Reactor Operator (SRO) and the other a Shift Technical Advisor (STA). This involvement enhances the ability of the IPE team to remain well informed of actual plant conditions and assures accurate modeling. Licensing and Safety, Clinton Plant Staff, Quality Assurance, and Nuclear Training departments provided support during the study.

A second team composed of senior IP personnel performed an independent review of the IPE products. This team was composed of supervisors and a director from the various on-site departments. Most of the review team held SRO licenses at CPS. Similar to the IPE team, all members of the review team are located at the plant site.

A management oversight team was also formed with various department managers and a vice-president of IP to review IPE progress and interim product reports. All of these members are also located at the plant site.

Consultants were used to augment technical expertise and provide technical advice, training, and review of the interim products. The consultants used were from the Individual Plant Evaluation Partnership (IPEP) which is composed of Tenera, L.P., Fauske and Associates, and Westinghouse Electric Corporation. These organizations were the primary contractors to the Industry

Degraded Core Rulemaking (IDCOR) program and have had extensive experience in risk assessment and perspectives that come only from experience with analysis of many plants. The IPEP provided technical people that were experts in specific aspects of PRA and also provided a Senior Management Support Team to provide technical review of the IPE program products, periodic program direction review and management assistance as requested by the Program Manager. IPEP also provided HRA expertise to assist in walkdowns, modeling, evaluating, and reviewing HRA aspects of the IPE.

Technology transfer from the consultant to IP employees was considered a very important part of the IPE program. All of the major work tasks were performed by the CPS IPE team members. Technology was transferred and experience gained throughout the IPE program. This approach will enable IP to use and enhance the risk assessment tool without external dependency.

The IPE organization chart is presented in Figure 5.1-1.

As mentioned earlier, the primary IPE team members have been at CPS since construction and start-up testing. They are listed below along with a brief description of their applicable experience:

P. E. Walberg, Technical Lead, Bachelor of Science degree in Mechanical Engineering, 26 years experience in nuclear power in the following areas: nuclear navy, engineering, and licensing and safety.

E. E. Tiedemann, Project Engineer, Bachelor of Science degree in Mechanical Engineering, active STA certification, 14 years experience in nuclear power in the following areas: construction, system engineering, and operations.

C. H. Mathews, Project Engineer, Bachelor of Science degree in Nuclear Engineering, active SRO license, 12 years experience in nuclear power in the following areas: reactor engineering, plant operations, plant startup testing and control room simulation.

M. E. O'Flaherty, Project Engineer, Bachelor of Science degree in Nuclear Engineering, 11 years experience in nuclear power in the following areas: naval prototype operations, nuclear and reactor engineering.

A. J. Hable, Project Engineer, Bachelor of Science degree in Mechanical Engineering, 10 years experience in nuclear power in the following areas: technical assessment of licensing issues and independent safety engineering group.

R. T. Kerestes, Project Manager, Bachelor of Science degree, 20 years experience in nuclear power in the following areas: nuclear navy prototypes, construction, start-up, field engineering, and engineering projects.

5.2 Composition of Project Review Teams

As indicated above, Illinois Power has had the primary role in each phase of the IPE, including overall project management, detailed review of interim products at every step, and critical analysis and evaluation of all results. The following sections discuss the various review groups used in support of the IPE project along with relevant information on the members. None of the IP review teams had previous PRA experience, but reviewed the IPE to ensure that it accurately modeled the CPS plant and the way it is operated. As the program developed, IP review team members gained a substantial appreciation for PRA methods. Their direct involvement in the process is expected to pay significant dividends in any future PRA applications. The consultant team has extensive PRA experience and reviewed the various products for consistency and adequacy with respect to PRA practices.

5.2.1 System Engineer Review

The CPS Nuclear Station Engineering organization includes a system engineering section. Each plant system is assigned to a system engineer. This system "expert" maintains a notebook of design features, characteristics, operation, testing, etc. for the assigned system. This system notebook contains a system description which included the following:

- 1) USAK references
- 2) Technical specification requirements
- 3) Power supply list
- 4) System interlocks
- 5) Drawing, procedure, and equipment lists, and
- 6) Surveillance and maintenance schedules and history.

The system description was used as one of the primary sources of modeler information for each system.

The system engineer functioned as a consultant to the IPE system modeler to answer questions about design, capability, and function of the system. He also reviewed each system model, including the fault tree and narrative, in order to ensure that the system was accurately modeled. In order for the system engineers to do this job effectively, they were trained in PRA terminology and methods.

Initial training for the system engineers was conducted by Tenera, with subsequent training performed by the IPE technical lead.

Comments generated by the system engineers during the course of this review were resolved and changes were made to the model as appropriate.

5.2.2 IPE Independent Review Team (IIRT)

The IPE Independent Review Team (IIRT) is an internal group of experienced IP personnel at the supervisor and director level and is located at the CPS site. The purpose of the team is to review the interim and final products that are listed in Section 2.3.7 in order to assure accurate representation of CPS design, operating history, operator response, maintenance and surveillance schedules, and recovery actions in the IPE study. In order to assure independence, none of the IIRT members were involved with producing any of the products reviewed.

Training for the IIRT team was conducted at several stages as the IPE progressed and as products were made ready for review. This training was performed by the IPE Technical Lead with assistance from IPEP, and afterward in conjunction with the frequently held IIRT meetings over the two year span of IPE review.

The IIRT is composed of six members. The chairman is the Director of Nuclear Safety, four of the other members have CPS SRO licenses, while the sixth member has extensive maintenance experience.

The IIRT members have diverse backgrounds and represent the following departments: operations, engineering, maintenance, licensing and safety, and nuclear training. The position titles of the members are listed below along with a short summary of their experience.

Director of Nuclear Safety (L&S), review team chairman, 20 years experience in BWR engineering and nuclear licensing, Master of Science degree in Nuclear Engineering.

Operations Task Coordinator (OPS), licensed SRO, 21 years nuclear navy and operations experience, including shift supervisor.

Senior Instructor-Training (NTD), licensed SRO, 22 years experience in nuclear navy, operations, and nuclear training.

Supervisor of NSSS Systems (NSED), licensed SRO, 14 years nuclear navy, operations, and engineering experience, Bachelor of Science degree in Nuclear Engineering.

Supervisor of Nuclear Engineering (NSED), licensed SRO, 18 years nuclear fuels and reactor engineering experience, Master of Science degree in Nuclear Engineering.

Supervisor C&I Maintenance (Maint), 18 years nuclear navy, CPS start-up, field engineering, and maintenance experience.

The diverse background and extensive experience of this review group provided many substantive technical, editorial, and program enhancing comments during the course of the IPE evaluation.

5.2.3 Senior Management Review Team (SMRT)

The purpose of the Senior Management Review Team (SMRT) is to provide program oversight and to review progress and results. The SMRT provided assurance that results were reasonable and bases for these results were adequately documented, facilitating future use by IP personnel. Insights developed during the course of the IPE study, including the capability of the plant to respond to severe accidents, were presented to SMRT.

The SMRT is made up of five department managers and is chaired by the Senior Vice-President of the Nuclear Program, see Figure 5.2-1. The department managers involved are the managers of Clinton Power Station, Nuclear Station Engineering, Quality Assurance, Licensing and Safety, and Nuclear Training. All SMRT members are located at the plant site. Training of the SMRT on various aspects of the IPE was provided by the IPE technical lead during the quarterly meetings.

5.2.4 Consultant Involvement

The prime consultant for the Clinton IPE was the Individual Plant Evaluation Partnership (IPEP), made up of Tenera, L.P., Fauske and Associates, Inc. (FAI), and Westinghouse Electric Corporation. These organizations were key contractors for the IDCOR program. As such, they have extensive experience in PRA methods and applications.

The primary interface between IP and the IPEP was the IPEP project advisor. He reported directly to the IP technical lead and served as the focal point for all interaction between IP and the IPEP. The IPEP had several major responsibilities.

- 1) Assist in correct and consistent implementation and interpretation of PRA guidance as applied to Clinton.
- 2) Provide training to the IPE group and assist the technical lead with providing training to review groups.
- 3) Provide an IPEP Senior Management Support Team (SMST) consisting of senior IDCOR people to provide a quasi-independent review of the CPS IPE. This role helps to provide the IPE with an industry overview perspective.
- 4) Provide a Human Reliability Assessment (HRA) expert to assist the IPE team with that portion of the evaluation.

The role that the IPEP performed helped to ensure the program was conducted and managed in a manner that fully satisfies the intent of the IPE program, as well as produce an integrated and consistent package of risk models for use by IP personnel.

5.2.5 Engineering Assurance Review

This review was performed by an on-site group that reviewed IPE program compliance with applicable instructions and procedures. Documentation techniques were reviewed for interim products, calculations, and updates to material.

5.3 Areas of Review and Major Comments

The areas of review were previously discussed under the respective review teams in Sections 5.2 and 2.3.7. Primary comments concerned modeling accuracy, additional justification and explanation.

5.4 Resolution of Comments

Comments were incorporated into the interim products at each stage of the project, before approval of each respective product. The final reports were more readable and more complete after inclusion of review teams' comments. This will assist the ongoing effort of the IPE as it will be easier for additional IP personnel to use the results of the IPE study.

To summarize, the independent review teams concluded that the study included sufficient information to constitute a thorough study that meets the intent of G.L. 88-20.

ILLINOIS POWER COMPANY
INDIVIDUAL PLANT EXAMINATION
PROGRAM MANAGEMENT ORGANIZATION

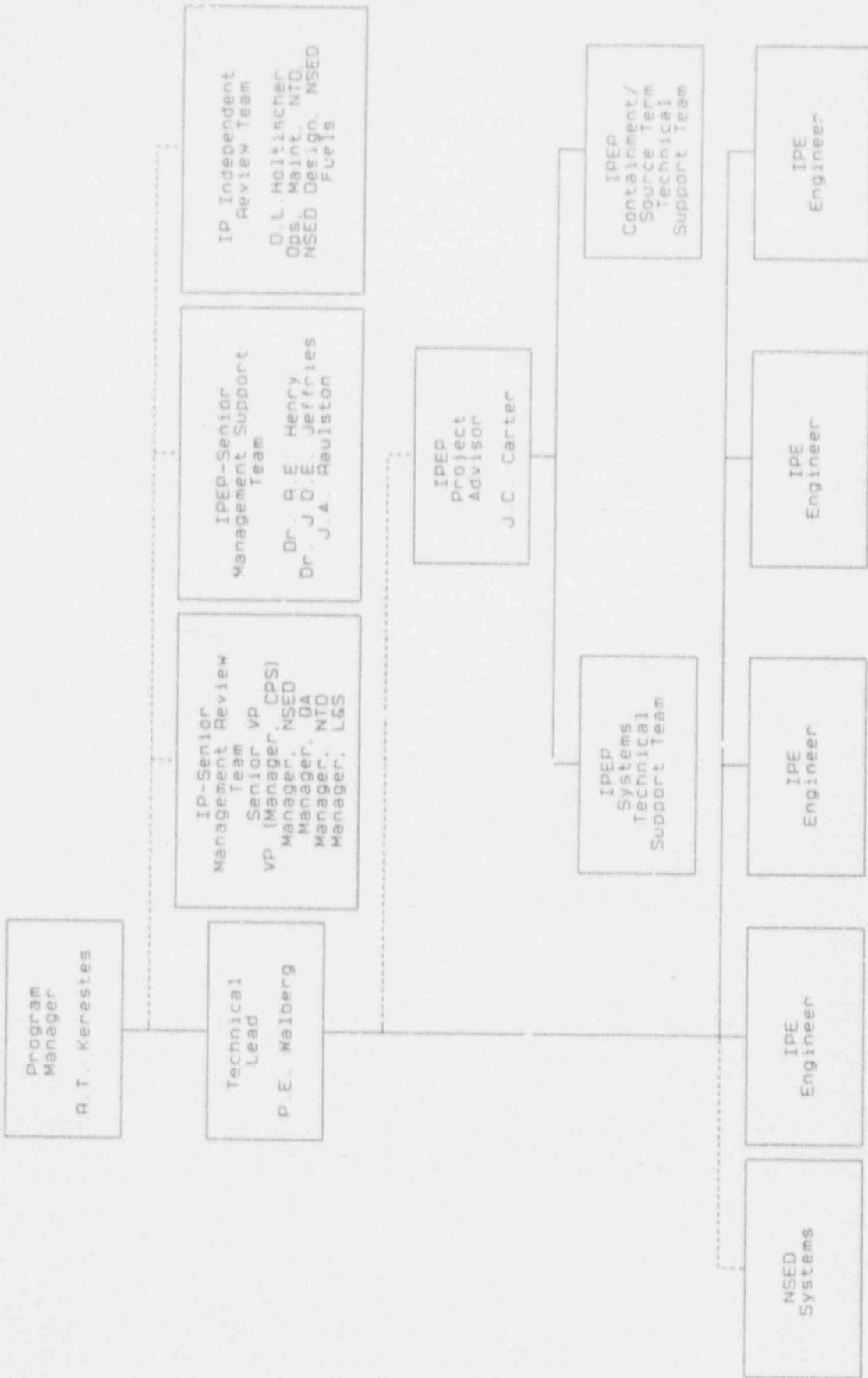

Figure 5.1-1

ILLINOIS POWER COMPANY
NUCLEAR PROGRAM ORGANIZATION

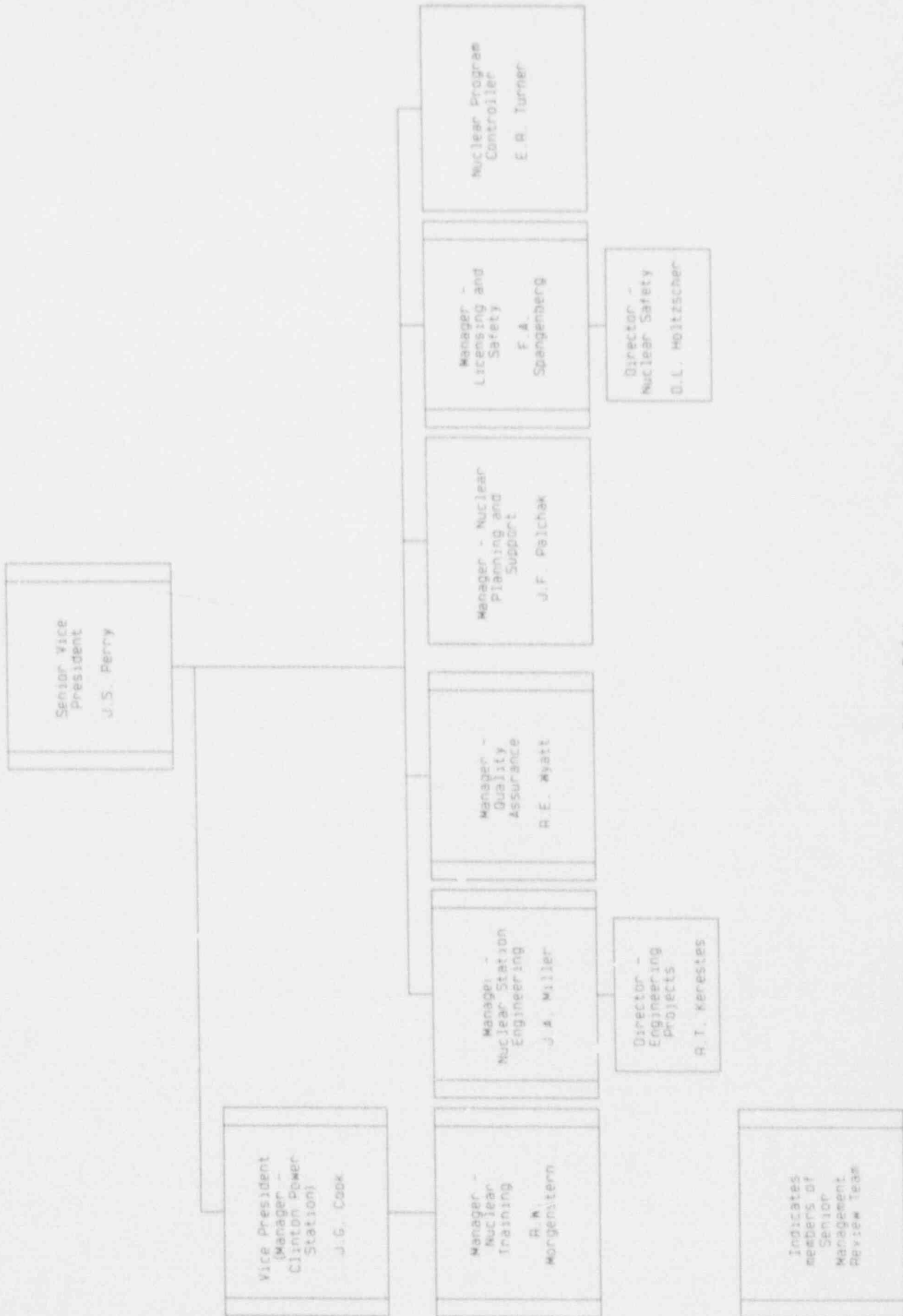

Figure 5 2-1

6.0 PLANT IMPROVEMENTS AND UNIQUE SAFETY FEATURES

6.1 Introduction

The purpose of this section is to present important features of the Clinton Power Station (CPS) design or operating practice that control the progression of core damage accidents and releases of radioactive material from the containment. Also identified are insights gained through performance of the IPE which could reduce or control plant risk.

The second section of this chapter (6.2) discusses unique and/or important CPS safety features which are important for understanding the CPS IPE results.

The third section of this chapter (6.3) discusses aspects of plant design and operation that are important for controlling the plant's core damage risk. These features were identified by the relatively high importance measures for their associated basic events. Potential cost-effective changes are identified, where applicable, which could reduce the core damage risk associated with these plant features. However, it should be noted that no vulnerabilities have been identified, and therefore, no immediate changes are required (see Section 3.4.2).

The fourth section of this chapter (6.4) discusses aspects of plant design and operation that are important for controlling the release of radioactive material from the containment in a severe accident. These features were identified by the relatively high importance measures for their associated basic events. Potential cost-effective changes are identified, where applicable, which could reduce the risk of radioactive release associated with these plant features.

The fifth section of this chapter (6.5) discusses issues to be addressed in the IPE which were identified by the Nuclear Regulatory Commission (NRC) in their correspondence with Illinois Power. Risk evaluations of these issues are provided as appropriate.

The sixth section of this chapter (6.6) discusses some further improvements that can be made to the CPS IPE model that have not been incorporated at the time of this report.

6.2 Unique or Important Safety Features For Clinton Power Station

This section discusses CPS plant features that tend to have a positive effect on plant safety. These features are not always obvious from a review of the cutsets produced during the quantification of the PRA because the PRA is quantified in "failure space", with the result being a list of combinations of failures (cutsets) that can cause core damage or containment radioactive release.

6.2.1 Equipment Independence

CPS utilizes three safety-related divisions of core cooling equipment that each have their own emergency diesel generators and cooling water pumps. No division relies on another to the extent that if equipment in one division were to fail it would cause failure of another. Spatial separation of the divisions is such that major mechanical and electrical equipment of each division are located in separate rooms. No internal flooding sources were identified that could cause the loss of more than one division.

The major things these divisions have in common are an off-site power supply (accounted for in the plant model by the LOOP initiator), the ultimate heat sink, the non-safety plant service

water system, the suppression pool, and the reactor vessel. It is very unlikely that any of these common factors could cause failure of all the safety-related divisions of equipment. These systems do have a similarity in design and components used, the same maintenance personnel, and the same operating personnel. These last three are accounted for in the IPE by common cause modeling.

Balance of Plant (BOP) systems that can provide cooling water to the reactor (Feedwater, Condensate, Condensate Booster, Fire Protection and Control Rod Drive), are independent of the safety-related systems. They are located in different areas of the plant and generally rely on different supporting systems. They do, however, (with the exception of Fire Protection) rely on the Plant Service Water system and the off-site power supplies which support the safety-related systems as well. The safety-related systems do not rely on Plant Service Water or off-site power supplies exclusively because they can be supplied from the safety-related Shutdown Service Water system and the emergency diesel generators.

The results of the CPS IPE support the conclusion that the CPS systems have a high degree of independence. The most likely combination of failures (cutset) leading to core damage contributes less than 2% of the total core damage risk. If there were a stronger dependence among systems, one would very likely be able to identify failure combinations that contribute heavily to the risk of core damage.

6.2.2 Feedwater Delivery System

In addition to the two turbine driven reactor feedwater pumps (TDRFP), CPS has a motor driven reactor feedwater pump (MDRFP). The MDRFP can supply water to the reactor regardless of the availability of motive steam and the main condenser, which are required for operation of the TDRFPs. Thus, the feedwater system

can provide core cooling water for transients with and without main steam line isolation. These transients account for the large majority of the initiating events the plant is expected to see. The value of the feedwater system as a core cooling system has been borne out by past CPS operating experience. In the approximately four and a half years CPS has been operating, only one instance has occurred in which a system other than feedwater was used for providing makeup water to the reactor after a reactor shutdown. In this event, in which Main Steam Isolation Valve (MSIV) closure eventually occurred, feedwater was used initially and was terminated minutes later in order to use RCIC for pressure and level control. The feedwater delivery system remained available and was subsequently put back into service after reactor pressure and level parameters stabilized.

6.2.3 Containment Design

CPS has a strong containment design in that it has the largest free air volume and suppression pool volume to rated thermal power of any domestic Mark III containment. These factors allow for a slower containment pressurization for a given accident sequence. The pressure retention capability of the CPS containment is estimated to be approximately 94 psig (the pressure at which the containment is estimated to have a 50% chance of failing). See Section 4.4.6 for further details. Few core damage accident sequences exceeded the pressure retention capability of the containment within the 48-hour mission time for the containment analysis.

6.3 Evaluation of Important Features Affecting Core Damage Risk

An evaluation was performed of the core damage cutsets to analyze those basic events or independent sub-trees with the highest importance measures. The core damage cutsets are the summation of all the failure sequence cutsets from all the core damage event trees. Thus, the importance measures for the core damage

cutsets reflect those features which have the greatest effect on the overall core damage risk. In the following discussion, if a particular plant feature has a much greater effect for a certain initiator or accident class, this will also be noted.

Table 6-1 shows the basic events or independent sub-trees with the highest Fussel-Vesely importance measures. Conceptually, the Fussel-Vesely importance measure means that the associated basic event appears in cutsets that constitute a fraction of the total probability equal to the Fussel-Vesely value. (Thus, if the failure probability of a basic event with a Fussel-Vesely value of 0.1 can be reduced by a factor of four (75% reduction), a 7.5% reduction in the top event probability would occur). The basic events or independent sub-trees with the highest Fussel-Vesely importance measures are good candidates for reliability improvements. The following discussion identifies potentially cost-effective improvements or other actions to be evaluated by CPS as applicable.

6.3.1 Loss of Off-site Power

The first two events, YLOOPXXTRX and YL1, are the Loss of Off-site Power (LOOP) initiator and the probability that off-site power will not be recovered in one half hour, respectively. These events are contained in virtually every class 1B (Station Blackout) cutset. See Table 6-2 for class 1B Fussel-Vesely values. These events are also important to a lesser extent to the transients. See Table 6-3 for class 1A (High Pressure) Transients. Loss of Off-site Power sequences that did not meet the CPS definition for Station Blackout were classified as transients (class 1A or 1D). The CPS definition for Station Blackout is a LOOP with both division 1 and division 2 diesel generator failures.

The LOOP initiator is significant because it makes unavailable all Balance Of Plant (BOP) systems, which are powered from the

off-site power supply after a generator trip. At the same time, it increases the likelihood of failure of safety-related systems because they now would depend on only their respective diesel generators for AC power.

The LOOP initiator highlights the importance of activities associated with the switchyard and transmission system supplying CPS. Industry experience has demonstrated that the majority of LOOP events are caused by plant centered factors such as switching errors, hardware failures, design deficiencies, and local weather-induced effects. This insight has been provided to the CPS training department, and they are evaluating what changes are appropriate to be made to the training program for emphasizing the care that should be given to activities associated with the off-site power system.

The LOOP initiator frequency used for CPS is $8.4E-2$ events per year and was derived primarily from industry data for different types of LOOP failures that have occurred at other sites. The specifics of the CPS off-site power connections were not taken into account under this derivation. Data from NSAC (Nuclear Safety Analysis Center) 182, "Losses of Off-Site Power at U.S. Nuclear Power Plants Through 1991", indicates that the industry average frequency for LOOP is approximately 0.03-0.04 events per unit year. Some of this difference can be accounted for by the difference in reporting the data on the basis of site years versus unit years. NSAC 182 uses the per unit basis because there have been few instances in which both units at a double unit site have lost off-site power at the same time. In any case, the strong off-site power supply design utilized at CPS makes the $8.4E-2$ value conservative.

6.3.2 High Pressure Core Spray Failures

The next two events, HISTINJECT and BISTHPINJR, are an independent sub-tree composed primarily of High Pressure Core

Spray (HPCS) hardware failures and a basic event representing recovery of HPCS failures. The HPCS system is important because it is a high pressure vessel inventory makeup system that is capable of responding to any initiating event. The HPCS system is not susceptible to the failures that can disable the BOP equipment (e.g. LOOP, loss of plant service water, and loss of BOP DC power).

The basic events composing independent sub-tree HISTINJECT were reviewed to see if any cost-effective reliability improvements could be identified. Basic event HPXF314XVP, SUPPRESSION POOL SUCTION ISOLATION VALVE OBSTRUCTED, was identified as a candidate for improvement. Valve 1E22F314 is on the HPCS pump suction line from the suppression pool. Because there is no requirement to test the suction supply from the suppression pool in any normally scheduled surveillance run of the HPCS pump, it is possible that obstructions of the suction isolation valve or line could go undetected for the remaining life of the plant. Therefore, because of the failure model used, obstruction of the suction isolation valve had a relatively large estimated failure rate. To correct this situation, CPS could modify the surveillance procedure for HPCS to periodically test the suction line from the suppression pool. For example, testing this suction line flow path at an interval of once per four years would result in an estimated 12.8% reduction in overall core damage risk. A proposed procedure change to provide for periodic testing of the HPCS suppression pool suction flow path has been provided to CPS plant staff, and they are evaluating it in their overall program for procedure maintenance.

6.3.3 Reactor Core Isolation Cooling Failures

The next two events, IISTINJECT and BISTRINJR, are an independent sub-tree composed primarily of Reactor Core Isolation Cooling (RCIC) hardware failures and a basic event representing recovery of RCIC failures. Like HPCS, RCIC is important because

it is a high pressure vessel inventory makeup system that can provide water to the reactor even when conditions that can impair BOP equipment occur. Like HPCS, it does not rely on reactor depressurization for operation.

RCIC has a higher importance than HPCS in Station Blackout (SBO) sequences because, unlike HPCS, it does not have an immediate dependency on AC power or service water. HPCS relies on the division 3 diesel generator and Shutdown Service Water under LOOP conditions.

These division 3 support systems also have some common cause failure potential with divisions 1 and 2 (divisions 1 and 2 must have failed for an SBO to occur), which RCIC does not. RCIC does have long-term dependencies on AC power (e.g. RCIC room cooling, Suppression Pool cooling and power for the battery chargers), but because of the generally favorable prospects of AC power recovery over the time which RCIC would be able to run without AC power, this dependency is less significant.

6.3.4 Depressurization Failures

The seventh and twelfth events, GADSMANSYW and GISTADSHDW, are respectively, a basic event representing operator failure to manually depressurize the reactor and an independent sub-tree representing a group of Automatic Depressurization System (ADS) hardware failures. These events are important because, in the current plant PRA model, either one of these failures can render low pressure injection systems (i.e. Low Pressure Core Spray, Low Pressure Coolant Injection, Condensate Booster, Condensate, and even Fire Protection) unavailable for the large majority of initiating events. Consequently these two events appear in cutsets composing 93% of the class 1A (high pressure transients) probability.

Basic event GADSMANSYW, OPERATOR FAILS TO MANUALLY INITIATE ADS, has a high Fussel-Vesely importance measure even though it has a low failure probability (5E-4). The need for a manual depressurization is caused by the Emergency Operating Procedures (EOPs) that direct ADS to be inhibited for virtually all scenarios. As a result, when low pressure systems are needed, ADS needs to be manually initiated. Without being inhibited, ADS would be truly automatic. The failure probability for GADSMANSYW was determined through a detailed Human Reliability Assessment (HRA) of this activity (See Section 3.3.3 of this report for a discussion of the HRA methods). Manual initiation of ADS has a low failure rate because:

- It is proceduralized,
- It is a simple operator action,
- Operators are well trained on the performance of initiating ADS, and
- Operators understand the relationship of reactor pressure and injection capabilities of low pressure systems.

The technical bases for the EOPs provide justification for inhibiting the automatic initiation of ADS, and CPS does not intend to modify this aspect of the EOPs at the present time. Although this operator action has a low estimated failure rate, this is an operator action that deserves attention because an increase in the failure rate of this activity could cause a large increase in the risk of core damage. GADSMANSYW has a relatively high Achievement Worth of 480. The Achievement Worth importance measure is the factor by which the risk (in this case, risk of core damage) would increase if the basic event had a failure probability of 1 (failed on every occasion). Because this is a crucial operator action for which the failure probability needs to be maintained low, the importance of this action has been emphasized to the CPS training department, and they are

evaluating whether any changes are appropriate to be made to the training programs to continue this emphasis.

GISTADSHDW represents a group of independent hardware failures associated with ADS. In the existing CPS PRA, the importance of ADS hardware failures is somewhat overstated because ADS was the only means of depressurization modeled, when in fact, there are other means available. For example, in situations in which the main condenser is available (which it would be under most transients) the reactor could be depressurized using the reactor pressure regulator which controls the turbine bypass valves. Alternately, the Turbine Driven Reactor Feedpumps (TDRFPs) could be run until they deplete sufficient steam pressure to allow the Condensate Booster system to supply the reactor without the feedwater pumps. (The TDRFPs have not been modeled as a high pressure makeup system for most scenarios because it is unclear whether the steam production rate of the reactor under decay heat conditions would produce sufficient steam to allow operation of the TDRFPs for the assumed 24-hour mission time.) The first of these methods (use of the pressure regulator) is far more typical of the way the reactor is depressurized during a normal shutdown of the plant. It is estimated that approximately a 3% reduction in calculated core damage risk could be obtained through the addition to the plant model of the pressure regulator as a means of depressurization.

6.3.5 Transient Initiators

The eighth and ninth events, YTRANSYTRX AND YTRANISTRX, are the transient without isolation and transient with isolation initiators, respectively. These are important because of the high frequency of the initiators, 4.7 and 1.7 events per year, respectively. These are by far the most likely of all CPS initiating events. They emphasize the importance of reliable plant operation, not only in achieving the company's economic goals, but in improving plant safety as well. These initiating

event frequencies are based on generic industry data because of the relatively short operating experience of CPS (approximately five years). Although there have been wide variations in performance, CPS has generally seen an improving trend (i.e. a reduction in these transient frequencies) in recent years.

6.3.6 Failures of the Fire Protection System as a Core Cooling System

The Fire Protection (FP) system has been modeled as a long-term core cooling system for low pressure transient sequences in which some other core cooling system runs for a period of time. Low reactor vessel pressure is required because the fire protection system pumps are low pressure pumps. Another system is required to run for a period of time because use of the fire protection system requires removal of the internals from a check valve to allow fire protection water to be supplied to the Plant Service Water system from which it can be directed to the reactor. Long-term-type failures for which the Fire Protection system was used for recovery include failures such as loss of room cooling, or failures of RCIC because of the failure of suppression pool cooling.

The importance of the Fire Protection system in low pressure transient sequences indicates that a large fraction of the low pressure core damage failure sequences involve these delayed failures. The importance of the FP system in these sequences is somewhat overstated; first, because these sequences are based on the assumption that loss of room cooling will necessarily cause failure of the equipment in the room being cooled, and second, because the FP system has been assumed to be the primary means of recovery for these failures. CPS utilizes individual ECCS and RCIC pump rooms each with their own room cooler supplied with cooling water from Shutdown Service Water. While this arrangement provides good separation between divisions and provides protection against flooding failures, it results in

areas that are not as readily cooled through natural heat transfer mechanisms as are some of the more "open" designs. The equipment located in these rooms has been environmentally qualified for high temperatures because of design basis conditions such as Loss of Coolant Accidents and High Energy Line Breaks. The room temperature rise expected to occur as a result of loss of room cooling with the associated ECCS pump running is estimated to exceed the environmental qualification envelope of the room only after a number of hours. Therefore, without performing further analysis, the equipment in these rooms was assumed to fail. This approach is somewhat conservative in that exceeding the equipment qualification envelope will not necessarily cause failure of the equipment. Because, at minimum, several hours are available before equipment in these rooms would fail, sufficient time would be available to make fire protection water available to the reactor. This period of time could also be used to address the room temperature problem directly by fixing the source of the room cooling problems or by propping doors open and using temporary fans.

The Fire Protection system's strength as a core cooling system is that it has few operational dependencies on other systems. Its operational dependencies are limited to the piping and valves from other systems that are used to transport fire protection water to the reactor. Usefulness of the Fire Protection system as a core cooling system is diminished by the fact that it is a low pressure system, and therefore, relies on reactor depressurization and by the time it takes to align it to supply water to the reactor. For example, the Fire Protection system has minimal value in Station Blackout sequences because the ADS SRVs will likely reclose after the batteries that support the ADS SRVs are depleted (see section 6.5.4.2). After the SRVs reclose, the reactor would repressurize making Fire Protection injection unavailable.

To make the Fire Protection system more useful as a core cooling system, a change to the piping could be made. Currently, to use the Fire Protection system as a core cooling system, the internals of check valve 1FP036 (a 12" check valve) have to be removed and the valve reassembled so that backflow can occur from the FP system into the Plant Service Water (WS) system. The check valve is installed such that WS is capable of flowing into the FP system from WS but not in the opposite direction. A bypass line could be installed around check valve 1FP036 with a normally closed valve in it. Then, if the FP system were required as a core cooling system, the bypass valve could be opened instead of performing the time-consuming task of removing the check valve internals. This would have two effects in reducing the core damage risk. First, it would dramatically reduce the amount of time required to align the FP system for injection into the reactor. This may make the FP system available for all low pressure sequences, because it is possible that the FP system could be aligned in time to prevent core damage with no other injection systems available. Second, it would make the alignment process more reliable (less failure prone) because opening a valve is much simpler than removing the internals from a check valve.

The reduction in core damage risk from such a change is estimated as follows. If the failure rate for establishing flow from the Fire Protection system to the Plant Service Water system can be reduced by a factor of two (from 0.5 to 0.25) by installation of the check valve bypass line, this would result in approximately a 6% reduction in the risk of core damage. If, in addition to this reliability improvement, the FP system is applied to all low pressure sequences (i.e. to both short-term and long-term failures of other makeup systems), the core damage risk would be reduced by a total (from both effects) of approximately 13%. To take credit for the FP system in instances in which the other reactor coolant makeup systems fail immediately would take a change in operating procedures and training. The plant operators

will very likely apply their efforts first to recovering some of the multiple equipment failures that would have occurred, rather than aligning the FP system for injection into the reactor. Thus, even though the operators could have aligned the FP system in time for reactor injection if they had begun from the onset of the loss of reactor coolant makeup, any delays associated with other recovery activities could make the availability of Fire Protection water too late to prevent core damage. To make Fire Protection available as a short-term cooling source would require procedure and training changes that would instill the operating philosophy of aligning the FP system immediately for injection into the reactor when the loss of injection occurred.

CPS will consider this hardware change as a possible future improvement in the plant design. However, this evaluation will be held in abeyance until completion of the Individual Plant Examination for External Events (IPEEE) and development of the Severe Accident Management Plan.

6.3.7 Power Recovery Failures Under LOOP Conditions

A number of power recovery basic events were used in the CPS IPE (YDG2R04DGH is associated with recovering the division 2 diesel generator within four hours.). Some of these events are diesel generator recoveries, some are recoveries of off-site power, and some involve both. They account for the increasing likelihood of recovering these power sources over time. These recovery events are sequence dependent and, in general, are conditional on the other power recovery events contained in a given cutset. Collectively, they are responsible for a large reduction in the core damage risk due to Station Blackout. The power recovery factors were determined from empirical industry data regarding recovery of off-site power and electrical power systems. The risk reduction these power recovery factors provide shows the significance of these power recovery headings.

Although the results of the IPE are not detailed enough to indicate which specific failures are most likely to occur, it would appear that a strong understanding of diesel generator and auxiliary power system operation would provide operations and maintenance personnel with the best opportunity for power recovery. The CPS Nuclear Training department has been made aware of this insight, and they are evaluating what changes are appropriate to be made to the training programs for diesel generator and auxiliary power system operation and maintenance.

6.3.8 Shutdown Service Water Starting Failures

Support system failures can contribute significantly to core damage sequences because they can disable several trains of core cooling systems. Therefore, fewer total independent failures would need to occur in order to cause core damage, and the resultant core damage cutsets tend to have higher probability. In addition to AC power systems discussed in some of the sections above, service water systems have also shown up as significant support systems. A typical combination of failures would be an initiating event (e.g. LOOP) that causes failure of Plant Service Water, which is a non-safety system, followed by a combination of failures that disable the Shutdown Service Water system (SX).

One of the leading failure modes for the SX System in the CPS IPE is the failure of SX pumps to start when required. The three SX pumps receive start signals when LOCA conditions exist (high drywell pressure or low reactor water level) or when the associated SX header pressure switches sense low header pressure. Because scenarios exist which may not result in the generation of a LOCA signal until significantly after the initiating event, the LOCA start signals were not modeled. The low header pressure signals were modeled because these provide a direct indication of the need for an SX pump start. Failure of the SX pump start on low header pressure was evaluated as being significant (especially common cause failures of the header pressure

instruments). Basic event BSXMANSTRT represents an operator action to recover from a failed SX discharge pressure instrument or instruments by manually starting the associated SX pump or pumps.

The probability value used for BSXMANSTRT is 0.5 which is a Human Reliability Assessment screening value. To improve the likelihood of successfully responding to a failure of SX automatic initiation, the procedures that would be used to identify and respond to SX initiation failures were reviewed. CPS procedure 3506.01, "Diesel Generator And Support Systems", was identified as a procedure in which improvement could be made. The diesel generators are particularly critical components in that they would fail within a short period of time without cooling water flow available because of their relatively high heat loads. CPS procedure 3506.01 already includes a provision to send an area operator to the diesel generator room anytime a manual or automatic initiation of any of the diesels occurs. The area operator's presence in the room should be sufficient to detect a lack of cooling water supply to the diesel. To improve the likelihood that SX initiations will occur in time to prevent damage to the diesel generator, a proposed procedure change to confirm that the SX pump has started when required has been provided to CPS plant staff, and they are evaluating it in their overall program for procedure maintenance.

For non-LOOP sequences, the time available to detect a lack of SX flow would generally be much longer because the failures associated with loss of room cooling would take longer to occur. Given the time available until failures would be expected to occur, the likelihood of detection in time to prevent equipment failures due to lack of room cooling is high.

6.4 Evaluation of Important Features Affecting Risk of Radioactive Release From the Containment

An evaluation was performed on the containment failure cutsets to analyze those basic events or independent sub-trees with the highest importance measures. Table 6-4 shows the basic events or independent sub-trees with the highest Fussel-Vesely values for the containment failure cutsets. These are the items that contribute most significantly to the containment radioactive release risk. The containment failure cutsets are the summation of all the containment failure sequence cutsets from all the containment failure event trees. Thus, the importance measures for the containment failure cutsets reflect those features which have the greatest effect on the overall containment radioactive release risk.

6.4.1 Loss of Off-site Power

The Loss of Off-site Power (LOOP) initiator YLOOPXXTRX is the dominant initiator leading to radioactive release from the containment. Event YL1 represents the probability that off-site power will not be recovered within 0.5 hours given that a LOOP has occurred. Station Blackout sequences, which originate from the LOOP initiator, can impair the containment isolation function because there are containment isolation valves that would fail open under loss of power conditions. Containment isolation valves would have to be manually isolated to ensure that a radioactive release from the containment would not occur. Because manually isolating valves that would not close automatically would involve local manual actions by area operators, this action has a high assumed failure rate. Other initiators have proven to be much less important because, with AC power available, the likelihood of a successful containment isolation is fairly high. Once containment isolation has occurred, containment failure is required for a radioactive release. Because of the robust containment design at CPS, decay

heat power levels alone will be insufficient to cause failure of the containment due to overpressurization within the period covered by the containment analysis (48 hours after event initiation). Under certain conditions, a hydrogen burn could cause a sufficient containment pressure rise to cause containment failure, but under non-Station Blackout conditions the hydrogen ignitors would generally be available to prevent the containment hydrogen concentration from reaching a level at which containment failure could occur due to a hydrogen burn.

The importance of the LOOP initiator to the occurrence of containment radioactive release reemphasizes the benefit of maintaining the exposure to loss of off-site power events low. Care should be given to the performance of activities involving the switchyard or the plant connection to the off-site power system. As mentioned above in Section 6.3.1, this insight has been transmitted to the CPS Nuclear Training department for emphasis to the plant operators.

6.4.2 Recovery of AC Power

There are a number of basic events appearing in the containment failure cutsets that represent recovery of AC power sources after a specified period of time. The containment analysis used more of these power recoveries than did the core damage study because, in addition to the events that represent power recovery in time to prevent core damage, the containment study also included events representing power recovery in time to protect radioactive release barriers once fuel damage has occurred (e.g., power recovery in time to prevent reactor vessel breach). Some events involve recovery of off-site power, some represent recovery of emergency diesel generators, and some represent both. In general, the recovery events are conditional on failure of previous recovery events. Collectively these power recovery events are important in preventing the release of radioactive materials from the containment. This is to be expected because

they are associated with SBO events which, as previously noted, are the leading risk contributor to radioactive release at CPS.

The recovery events show that, in addition to being able to prevent a Loss of Off-site Power or Station Blackout in the first place, the ability to recover power within a reasonable time period is also important. To provide the best opportunity for power recovery, a strong understanding of AC power system and diesel generator system operation would be beneficial. The CPS Nuclear Training department has been made aware of this insight, as mentioned in Section 6.3.7.

6.4.3 Failure to Isolate the Containment Under Station Blackout Conditions

BNOSBOISOL is a recovery event representing the operator actions to manually complete a containment isolation under Station Blackout (SBO) conditions. Many of the key containment isolation valves are closed during power operation. Others are air operated and fail closed upon loss of off-site power (e.g., the main steam isolation valves and the Containment Continuous Purge system isolation valves). Other containment penetrations involve closed piping systems through which radioactive material could not pass unless a breach in the piping occurred. After these containment release paths are eliminated from consideration, only one release path remains. A containment release flow path would exist in the Fuel Pool Cooling and Cleanup (FC) line that returns overflow water from the upper containment pools to the surge tanks which are located outside of the containment. This containment release path could be isolated by manually closing valve 1FC008 (a 10" gate valve), which is located in the Fuel Building. BNOSBOISOL represents the probability that the operators will fail to isolate this containment release path in time to prevent a release of radioactive material from the containment under SBO conditions. BNOSBOISOL has been assigned a failure probability of 0.4, which is an HRA screening value.

This activity is covered in the Loss of AC Power procedure which directs that appropriate containment isolation valves be manually positioned as required. Valve 1FC008 is included in the list of containment isolation valves in this procedure. Time would generally be available for performing these manual isolations because about two hours elapse before significant amounts of radioactive material are released into the containment atmosphere. The key nature of valve 1FC008 for containment isolation in event of station blackout has been emphasized to the CPS training department, and they are evaluating what changes are appropriate to be made to the training programs concerning station blackout.

6.4.4 High Pressure Core Spray and Reactor Core Isolation Cooling Failures

HPCS and RCIC failures are important failures associated with Station Blackout (See Table 6-2). Because SBO sequences are the dominant contributors to containment failures, HPCS and RCIC failures also show up as being important in preventing containment radioactive release. See the discussion on HPCS and RCIC failures in Section 6.3.

6.4.5 SCRAM Hardware Failures

Although Anticipated Transient Without SCRAM (ATWS) sequences contribute relatively little to the overall core damage risk, they are noticeable contributors to the risk of a radioactive release from the containment. Essentially, the containment systems are much better at responding to other sequences such that SBO and ATWS sequences are the primary core damage sequences left that contribute to a containment radioactive release.

ATWS sequences appear in the containment failure cutsets because of the large amount of energy that can be produced by a reactor that has not been shutdown. If the main condenser heat sink

becomes unavailable during ATWS sequences, this energy is released to the containment in the form of steam. Under these conditions, it has been assumed that containment heat removal systems would be inadequate to prevent containment heatup and pressurization (e.g., even both trains of suppression pool cooling together were assumed to be inadequate to remove the heat generated from an ATWS event with loss of the main condenser). With this large power input into the containment, the temperature of the suppression pool would increase and containment failure due to overpressurization would occur before the 48 hours assumed as the mission time for the containment analysis.

An examination of the ATWS containment failure cutsets reveals the following general combinations of events that cause containment failure. A transient initiator with SCRAM hardware failures, failure of Standby Liquid Control, and failures that impair the Feedwater/Main Condenser combination. The Feedwater/Main Condenser combination can remove energy from the containment at a sufficient rate to prevent safety relief valves from opening and the containment from being over-pressurized even if the reactor can not be shut down.

SCRAM hardware failures (e.g. failures of the SCRAM discharge volume) are the primary means whereby an ATWS can occur. SCRAM initiation failures are less likely because multiple means of SCRAM initiation exist. Maintaining a highly reliable SCRAM system is a good defense against ATWS scenarios. Care should be exercised in the maintenance and operation of SCRAM equipment, and any design changes to this equipment should be carefully reviewed for possible reductions in the reliability of this equipment. The impact of SCRAM system failures has been emphasized to the CPS training department, and they are evaluating what changes are appropriate to be made to the training programs concerning SCRAM hardware.

6.5 Additional Risk Evaluations

Sections 6.3 and 6.4 discussed plant features which significantly affect the plant's risk as evidenced by the Fussel-Vesely importance measures for the associated basic events or independent sub-trees. This section discusses the safety significance of some other aspects of CPS that were evaluated in the process of performing the IPE. These issues were raised in various supplements to Generic Letter 88-20 or other correspondence from the NRC.

6.5.1 Preventive Maintenance Outage Time

Preventive maintenance outage basic events individually have relatively low Fussel-Vesely values such that they do not appear in the list of basic events with leading Fussel-Vesely values contained in Table 6-1. There are, however, a number of preventive maintenance events, so they collectively could be significant.

CPS utilizes a 12-week rolling schedule for performing many preventive maintenance tasks. An evaluation was performed of the impact of the system outage times associated with the 12-week rolling schedule on the core damage probability. The results of this study show that even if the duration of out-of-service time for preventive maintenance for systems in the 12-week rolling schedule were reduced by a factor of two, the core damage probability would decrease by less than 5%. This analysis was simplified in that it neglected the increase in corrective maintenance and random failure probability due to this reduction in preventive maintenance. Therefore, this estimated reduction in core damage probability is considered conservative. CPS concluded that the concept of the 12-week rolling maintenance schedule is not a significant safety issue.

6.5.2 Adequacy of Safety-Related DC Power Supplies

Generic Letter 91-06 requested information concerning design and maintenance practices for DC power supplies (Unresolved Safety Issue A-30). Illinois Power letter U-601899, dated October 28, 1991, provided the CPS response to this request with justification for the CPS design. In addition, the results of the IPE show that all DC failures, including equipment failures (e.g. breakers, batteries, and chargers), operator errors and maintenance unavailabilities contribute to cutsets composing approximately 5% of the total core damage frequency. Therefore, no weakness in the CPS DC power supplies is evident.

6.5.3 Hydrogen Control Measures and Effects of Hydrogen Burns on Safety Equipment

As part of the closure in Unresolved Safety Issue A-48, the NRC requested in NUREG 1417, "Safety Evaluation Report Related to Hydrogen Control Owners Group Assessment of Mark III Containments", that licensees consider the evaluation of an alternate power supply for the hydrogen ignition system as part of the IPE. Although the frequency of severe accident sequences leading to containment failure at CPS is very low, it could be lowered further by installation of a backup power supply to the ignitors. Sequences TL51, TL52 and TL53 from Figure 4.5-2, which are now release sequences, could be eliminated as containment failure sequences if the ignitors were continuously energized. This could result in a reduction of the containment release frequency from $1.28E-6$ to $8.76E-7$, assuming a 90% availability of the alternate power source. Under the same assumptions, it would reduce the frequency of a large release (class III) from $7.52E-7$ to $7.4E-7$. However, the current large release frequency is below the NRC safety goal of less than $1E-6$; therefore, CPS concluded that alternate ignitor power supplies are not justified.

6.5.4 Containment Improvements

Supplement 3 to Generic Letter 88-20 requested utilities with Mark III containments to evaluate backup power to the hydrogen ignitors; evaluate Mark I improvements from supplement 1 of Generic Letter 88-20; and evaluate containment heat removal as specified for Mark II containments. Each of these is discussed below.

6.5.4.1 Hydrogen Ignitor Backup Power

The impact of backup power to hydrogen ignitors was previously discussed in section 6.5.3.

6.5.4.2 Mark I Improvements

Enclosure 2 to supplement 1 to Generic Letter 88-20 listed the following improvements to be considered in the IPEs.

<u>IMPROVEMENT</u>	<u>STATUS</u>
(a) Alternate Water Supply	The Fire Protection System as defined in CPS procedures was included in the IPE. (See Section 6.3.6)
(b) Enhanced Depressurization Reliability	The backup air supply for the Automatic Depressurization System (ADS) has been included in the IPE models. No backup currently exists for depletion of batteries for the ADS function. Such a backup could reduce the frequency of sequence TLU1L4DG1DG2 on Figure 3.1-8 by approximately a factor of 2, reducing the core damage frequency of Station Blackout sequences by about 25% and overall core damage frequency by about 10%. Changes to extend the duration of the power supply for the ADS Safety Relief Valves may

be considered as part of the Severe Accident Management Plan.

(c) Emergency Procedures and Training

CPS has fully implemented Revision 4 to the BWR Emergency Procedure Guidelines and this is reflected in the IPE.

6.5.4.3 Mark II Containment Heat Removal

Analysis discussed in section 3 demonstrated that adequate containment heat removal is not a significant factor in the CPS IPE except in ATWS scenarios. Venting and suppression pool cooling, although directed by Emergency Operating Procedures, have not been demonstrated as being effective in preventing containment failure for ATWS scenarios. As a result, credit for these was not taken in the IPE analysis. Despite this, the CPS containment failure probability is relatively low.

6.6 Model Improvements

Some potential modeling improvements have been identified too late to be included in this report. Some of these would eliminate unnecessary conservatism in the results, while other improvements would make the models more accurate for future applications but are not expected to significantly change the results. Some of these have already been discussed in sections 6.3 and 6.4. However, two others are noteworthy.

6.6.1 Diesel Recovery Failures

Some double counting of diesel recovery failures was detected in the IPE results (i.e., there are some cutsets that are illogical and could be eliminated). Elimination of the double counting could reduce the frequency of sequence TLU1L4DG1DG2 from 4.59E-6 to 3.9E-6, reducing the Station Blackout core damage frequency by about 7% and overall core damage frequency by about 3%.

6.6.2 Manual Initiation of Suppression Pool Cooling

Section 3.3.3.1.8 identified the importance of manual initiation of suppression pool cooling to the success of long-term RCIC operation. The Human Reliability Assessment (HRA) screening value assigned to this action is felt to be very conservative. It is expected that a detailed HRA would reduce its frequency by about an order of magnitude. This would affect several sequences and it is expected that overall core damage frequency could be reduced by about 4 percent.

6.6.3 Other Improvements

Other potential modeling improvements would aid in future applications of the IPE, but would not likely have significant impact on overall core damage frequency or radioactivity release.

Table 6-1

Basic Events or Independent Sub-trees

With Highest Fussel-Vesely Importance

Measures for the Core Damage Cutsets

Basic Event or IST Designator	Fussel- Vesely Value	Probability or Frequency*	Basic Event or Independent Sub-tree Description
YL1	5.01E-1	4.21E-1	FAILURE TO RECOVER OFF-SITE POWER IN 0.5 HOURS
YLOOPXXTRX	5.00E-1	8.4E-2/yr	LOSS OF OFF-SITE POWER INITIATOR
HISTINJECT	4.15E-1	5.00E-2	INDEPENDENT SUB-TREE CONSISTING OF HPCS FAILURE BASIC EVENTS
BISTHPINJR	4.15E-1	7.18E-1	BASIC EVENT REPRESENTING RECOVERY OF HPCS FAILURES IN HISTINJECT
IISTINJECT	2.88E-1	5.46E-2	INDEPENDENT SUB-TREE CONSISTING OF RCIC FAILURE BASIC EVENTS
BISTRINJR	2.88E-1	7.56E-1	BASIC EVENT REPRESENTING RECOVERY OF RCIC FAILURES IN IISTINJECT
GADSMANSYW	2.41E-1	5.00E-4	OPERATOR FAILS TO MANUALLY INITIATE ADS
YTRANSYTRX	1.85E-1	4.70E+0/yr	TRANSIENT WITHOUT ISOLATION INITIATOR
YTRANISTRX	1.60E-1	1.70E+0/yr	TRANSIENT WITH ISOLATION INITIATOR
EISTFIREPR	1.30E-1	5.06E-1	INDEPENDENT SUB-TREE CONSISTING OF FIRE PROTECTION SYSTEM (AS A CORE COOLING SYSTEM) FAILURES
YDG2R04DGH	1.29E-1	8.00E-1	FAILURE TO RECOVER THE DIVISION 2 DIESEL WITHIN FIRST 4 HOURS OF STATION BLACKOUT
GISTADSHDW	1.05E-1	3.63E-4	INDEPENDENT SUB-TREE CONSISTING OF ADS HARDWARE FAILURES
BSXMANSTRT	1.01E-1	5.00E-1	BASIC EVENT REPRESENTING RECOVERY FROM SHUTDOWN SERVICE WATER (SX) AUTOMATIC INITIATION FAILURES BY MANUAL INITIATION OF SX

* All initiating events have units of 1/yr, all other events are unitless.

Table 6-2

Basic Events or Independent Sub-trees
With Highest Fussel-Vesely Importance
Measures for the Class 1B (Station Blackout)

Core Damage Cutsets

Basic Event or IST Designator	Fussel- Vesely Value	Probability or Frequency*	Basic Event or Independent Sub-tree Description
YL1	1.00E+0	4.21E-1	FAILURE TO RECOVER OFF-SITE POWER IN 0.5 HOURS
YLOOPXXTRX	9.99E-1	8.4E-2/yr	LOSS OF OFF-SITE POWER INITIATOR
IISTINJECT	4.05E-1	5.46E-2	INDEPENDENT SUB-TREE CONSISTING OF RCIC FAILURE BASIC EVENTS
BISTRIINJR	4.05E-1	7.56E-1	BASIC EVENT REPRESENTING RECOVERY OF RCIC FAILURES IN IISTINJECT
YDG2R04DGH	3.46E-1	8.00E-1	FAILURE TO RECOVER THE DIVISION 2 DIESEL WITHIN FIRST 4 HOURS OF STATION BLACKOUT
YDG1R04DGH	2.58E-1	8.00E-1	FAILURE TO RECOVER THE DIVISION 1 DIESEL WITHIN FIRST 4 HOURS OF STATION BLACKOUT
YOSOTO4SWH	2.58E-1	4.50E-2	FAILURE TO RECOVER OFF-SITE POWER WITHIN FIRST 4 HOURS OF STATION BLACKOUT (CONDITIONAL TO FAILURE TO RECOVER WITHIN 0.5 HOURS)
HISTINJECT	2.17E-1	5.00E-2	INDEPENDENT SUB-TREE CONSISTING OF HPCS FAILURE BASIC EVENTS
BISTHPINJR	2.17E-1	7.18E-1	BASIC EVENT REPRESENTING RECOVERY OF HPCS FAILURES IN HISTINJECT
YDCLOADSWH	2.10E-1	2.98E-2	FAILURE TO SHED DC LOADS TO PROLONG DIVISIONAL BATTERY LIFE
YDG1R01DGH	2.09E-1	9.90E-1	FAILURE TO RECOVER THE DIVISION 1 DIESEL WITHIN FIRST HOUR OF STATION BLACKOUT

* All initiating events have units of 1/yr, all other events are unitless.

Table 6-2 Continued

Basic Event or IST Designator	Fussel- Vesely Value	Probability or Frequency	Basic Event or Independent Sub-tree Description
YOSOTO1SWH	2.09E-1	5.94E-1	FAILURE TO RECOVER OFF-SITE POWER WITHIN FIRST HOUR OF SBO (CONDITIONAL TO FAILURE TO RECOVER WITHIN 0.5 HOURS)
AISTDGASTR	1.43E-1	2.31E-2	INDEPENDENT SUB-TREE CONSISTING OF DIVISION 1 DIESEL GENERATOR FAILURES
AISTDGBSTR	1.41E-1	2.31E-2	INDEPENDENT SUB-TREE CONSISTING OF DIVISION 2 DIESEL GENERATOR FAILURES
A2DG1KADGM	1.39E-1	2.63E-2	DIVISION 1 DIESEL GENERATOR OUT FOR CORRECTIVE MAINTENANCE
AISTDGCSTR	1.25E-1	2.31E-2	INDEPENDENT SUB-TREE CONSISTING OF DIVISION 3 DIESEL GENERATOR FAILURES
YDG2R01DGH	1.21E-1	9.90E-1	FAILURE TO RECOVER THE DIVISION 2 DIESEL WITHIN FIRST HOUR OF SBO
A2DG1KCDGM	1.18E-1	2.63E-2	DIVISION 3 DIESEL GENERATOR OUT FOR CORRECTIVE MAINTENANCE
BSXMANSTRT	1.18E-1	5.00E-1	BASIC EVENT REPRESENTING FAILURE TO RECOVER FROM SHUTDOWN SERVICE WATER (SX) AUTOMATIC INITIATION FAILURE, BY MANUAL INITIATION OF SX

* All initiating events have units of 1/yr, all other events are unitless.

Table 6-3

Basic Events or Independent Sub-trees
 With Highest Fussel-Vesely Importance
Measures for the Class 1A (High Pressure)

Core Damage Cutsets

Basic Event or IST Designator	Fussel- Vesely Value	Probability or Frequency*	Basic Event or Independent Sub-tree Description
GADSMANSYW	6.47E-1	5.00E-4	OPERATOR FAILS TO MANUALLY INITIATE ADS
HISTINJECT	6.08E-1	5.00E-2	INDEPENDENT SUB-TREE CONSISTING OF HPCS FAILURE BASIC EVENTS
BISTHPINJR	6.08E-1	7.18E-1	BASIC EVENT REPRESENTING RECOVERY OF HPCS FAILURES IN HISTINJECT
YTRANSYTRX	3.76E-1	4.70E+0/yr	TRANSIENT WITHOUT ISOLATION INITIATOR
YTRANISTRX	3.75E-1	1.70E+0/yr	TRANSIENT WITH ISOLATION INITIATOR
IISTINJECT	3.67E-1	5.46E-2	INDEPENDENT SUB-TREE CONSISTING OF RCIC FAILURE BASIC EVENTS
BISTRINJR	3.67E-1	7.56E-1	BASIC EVENT REPRESENTING RECOVERY OF RCIC FAILURES IN IISTINJECT
GISTADSHDW	2.85E-1	3.63E-4	INDEPENDENT SUB-TREE CONSISTING OF ADS HARDWARE FAILURES
FISTRESTRB	2.39E-1	1.23E-1	FAILURE TO RECOVER FEEDWATER TRIP GIVEN FAILURE OF MANUAL ADS
FFWCCORTRM	2.36E-1	6.00E-2	MOTOR DRIVEN REACTOR FEEDWATER PUMP OUT FOR CORRECTIVE MAINTENANCE
YRIPRORFRC	1.85E-1	1.00E-1	BASIC EVENT REPRESENTING FRACTION OF TRANSIENTS WITH ISOLATION THAT RESULT IN LOSS OF RCIC
RSPCOOLSWW	1.29E-1	5.04E-2	FAILURE TO INITIATE RHR SUPP POOL COOLING
YL1	1.16E-1	4.21E-1	FAILURE TO RECOVER OFF-SITE POWER IN 0.5 S
YLOOPXXTRX	1.16E-1	8.40E-2	LOSS OF OFF-SITE POWER INITIATOR

* All initiating events have units of 1/yr, all other events are unitless.

Table 6-4

Basic Events or Independent Sub-trees
With Highest Fussel-Vesely Importance
Measures for the Containment Failure
(Radioactive Release) Cutsets

Basic Event or IST Designator	Fussel-Vesely Value	Probability or Frequency*	Basic Event or Independent Sub-tree Description
YLCOPXXTRX	9.00E-1	8.4E-2/yr	LOSS OF OFF-SITE POWER INITIATOR
YL1	8.96E-1	4.21E-1	FAILURE TO RECOVER OFF-SITE POWER IN 0.5 HOURS
YDG2R04DGH	7.44E-1	8.00E-1	FAILURE TO RECOVER THE DIVISION 2 DIESEL WITHIN FIRST 4 HOURS OF STATION BLACKOUT
YDG1R04DGH	7.28E-1	8.00E-1	FAILURE TO RECOVER THE DIVISION 1 DIESEL WITHIN FIRST 4 HOURS OF STATION BLACKOUT
YOSOTO4SWH	7.28E-1	4.50E-2	FAILURE TO RECOVER OFF-SITE POWER WITHIN FIRST 4 HOURS OF STATION BLACKOUT (CONDITIONAL TO FAILURE TO RECOVER WITHIN 0.5 HOURS)
BNCSBOISOL	5.66E-1	4.00E-1	FAILURE OF CONTAINMENT ISOLATION IN STATION BLACKOUT SEQUENCES (MANUAL ISOLATION BY OPERATORS)
BOSOTO4SWH	5.47E-1	7.60E-1	FAILURE TO RECOVER OFF-SITE POWER IN TIME TO PREVENT RPV FAILURE (CONDITIONAL TO FAILURE TO RECOVER WITHIN 4 HOURS)
BLATERKCVY	3.30E-1	4.69E-1	CONDITIONAL FAILURE TO RECOVER OFF-SITE POWER IN 4 HOURS GIVEN FAILURE TO RECOVER IN 2
BSBOISOLOK	3.30E-1	6.00E-1	COMPLEMENT EVENT FOR FAILURE OF STATION BLACKOUT CONTAINMENT ISOLATION FAILURE
HISTINJECT	2.06E-1	5.00E-2	INDEPENDENT SUB-TREE CONSISTING OF HPCS FAILURE BASIC EVENTS

* All initiating events have units of 1/yr, all other events are unitless.

Table 6-4 Continued

Basic Event or IST Designator	Fussel- Vesely Value	Probability or Frequency*	Basic Event or Independent Sub-tree Description
BISTHPINJR	2.06E-1	7.18E-1	BASIC EVENT REPRESENTING RECOVERY OF HPCS FAILURES IN HISTINJECT
BDGRCTDDR4	1.30E-1	8.70E-1	FAILURE TO RECOVER DIESEL GENERATOR ISTS IN TIME TO AVOID RPV FAILURE
BDGRUNDDR4	1.30E-1	1.91E-1	FAILURE OF TIME-PHASED DIESEL RUN RECOVERY IN FOUR HOURS
AISTDGARUN	1.14E-1	5.41E-2	INDEPENDENT SUB-TREE CONSISTING OF DIVISION 1 DIESEL GENERATOR RUNNING FAILURE BASIC EVENTS
AGABCCCDJS	1.13E-1	2.00E-4	EMERGENCY DIESEL GENERATOR DIVISIONS 1, 2 AND 3 FAIL TO START COMMON CAUSE
IISTINJECT	1.13E-1	5.46E-2	INDEPENDENT SUB-TREE CONSISTING OF RCIC FAILURE BASIC EVENTS
BISTRIINJR	1.13E-1	7.56E-1	BASIC EVENT REPRESENTING RECOVERY OF RCIC FAILURES IN HISTINJECT
AISTDGBRUN	1.08E-1	5.41E-2	INDEPENDENT SUB-TREE CONSISTING OF DIVISION 2 DIESEL GENERATOR RUNNING FAILURE BASIC EVENTS
AISTDGASTR	1.06E-1	2.31E-2	INDEPENDENT SUB-TREE CONSISTING OF DIVISION 1 DIESEL GENERATOR FAILURES
AISTDGCSTR	1.06E-1	2.31E-2	INDEPENDENT SUB-TREE CONSISTING OF DIVISION 3 DIESEL GENERATOR FAILURES
A2DG1KADGM	1.04E-1	2.63E-2	DIVISION 1 DIESEL GENERATOR OUT FOR CORRECTIVE MAINTENANCE
YXSCRAMTRX	1.04E-1	1.00E-5	SCRAM SYSTEM HARDWARE FAILURES

* All initiating events have units of 1/yr, all other events are unitless.

7. SUMMARY AND CONCLUSIONS

The CPS internal events PRA consisting of a level 1 systems analysis and a level 2 containment performance analysis has been completed using current acceptable methods. It was intended to determine whether plant-unique vulnerabilities exist and to develop an appreciation for the behavior of CPS during severe accident conditions. The major conclusions of this study are that CPS design and operation provide good protection against core damaging accidents with a calculated core damage frequency of $2.6E-5$ events/reactor year. This value is below the NRC safety goal of $1.0E-4$ events/reactor year for core damaging events and is well within the range of recent published PRAs. There are no particular combinations of failures that stand out as dominant contributors to core damage. CPS has a robust containment design with a resultant low, calculated containment failure rate amounting to approximately 1 core damage event in 20 leading to containment failure. This result shows that the expected CPS containment failure rate is lower than that of many other nuclear plants. There are no plant vulnerabilities identified in the course of this study.

The CPS IPE was performed by a team of CPS employees, along with extensive CPS management involvement throughout the development process. This team was supplemented with contract personnel with PRA experience to assure that the CPS IPE followed standard PRA practices. The CPS IPE Team members have the technical and operational background and experience to examine and understand the plant design, operations, maintenance, emergency procedures, and surveillances, which allowed them to identify initiating events applicable to CPS; model the plant based upon practical experience concerning equipment and operator behavior; develop system and support system dependencies with assurance of completeness; and develop insight into the complexity, strengths and weaknesses of the plant response to a variety of severe accident conditions.

The formal in-house reviews performed during the course of the IPE resulted in assurance of the accuracy of the IPE documentation as well as a validation of the IPE process and results. These reviews also helped disseminate knowledge about the IPE and plant accident behavior.

The CPS IPE project accomplished the following objectives:

1. Developed an appreciation of severe accident behavior at CPS.
2. Developed understanding of the most likely severe accident sequences that could occur at CPS.
3. Gained a more quantitative understanding of the overall probabilities of core damage sequences and fission product releases from CPS.
4. Identified potential hardware and procedure modifications that could be implemented to further reduce the likelihood of core damage or containment failure.
5. Enhanced internal risk assessment skills and knowledge, established a baseline database, developed a set of risk models and instructions so that CPS will be able to use and maintain the CPS IPE for applications such as evaluating potential modifications, procedure changes, or material conditions.

The CPS IPE used an integrated systematic approach to examine the Clinton Power Station (CPS) for possible significant risk contributions. Development of the CPS IPE began by identification of the comprehensive initiating event list upon which all subsequent work was built. Then the potential progression of events that lead to either a safe shutdown condition or a core damage situation was ascertained. The modeling and evaluation of plant systems or major operator actions that could mitigate the effects of the different initiating events were then performed using event trees as tools. The logic structure of the event trees is generally consistent with the operating approach taken in the Emergency Operating Procedures (EOPs). Their consistency in structure with the EOPs

makes these tools useful in evaluating operations-related safety issues. The event trees were reviewed for agreement with the appropriate system procedures and the Emergency Operating Procedures by experienced IPE analysts and in-house review team members to ensure that they included the appropriate operational perspectives and adequately addressed the important operator actions. NUREG/CR-4550, "Analysis of Core Damage Frequency: Grand Gulf, Unit 1 Internal Events", was used as a pattern for the event trees. After the structure of the event trees was determined, system fault trees were developed. The fault trees provide detail on each of the systems modeled in the CPS IPE to show important components and how failure could affect the system. Failures modeled include human errors, hardware failures, and common cause failures. This resulted in a detailed study of the failure mechanisms of each system.

The CPS IPE level 2 containment performance analysis used the same integrated systematic approach as the level 1 analysis described above. The containment performance analysis began with the level 1 sequence end states, grouped (binned) according to their expected effect on containment response. Next, containment event trees were developed for each bin of core damage sequence end states. These event trees were then solved to determine the containment failure probability and the release source term, if applicable.

The development of the CPS IPE and its results received extensive internal and external reviews by technical and management level individuals. The final results represent an accurate model of Clinton Power Station with which PRA applications have been performed. While the final numerical values for core damage and containment failure probabilities may be subject to change as models are refined through application and maintenance, the relative order and importance of the sequences are considered reasonable and not subject to significant change due to minor assumption revisions. No single initiator dominates the core

damage frequency, and no severe accident vulnerabilities requiring immediate corrective action were identified.

The CPS IPE results indicate a core damage frequency of $2.6E-5$ per year based upon the present, as-operated, CPS reactor, plant, and containment capabilities. The significant core damage contributors are Station Blackout (long and short term) and Transients. These contributors account for 37.2% and 52.0% of the total core damage frequency. The results from the containment performance analysis indicate a containment failure rate of 5%. Containment failures were determined to occur in ATWS, and some SBO and low pressure core damage sequences.

The low core damage and containment failure probabilities are attributable to the fact that CPS is one of the newest design BWR-6 plants with a Mark III containment. Features built into the plant that contribute to these lower probabilities include the following:

1. Three separate emergency electrical buses, each with their own Diesel Generator.
2. Pressure suppression containment design.
3. A strong and large volume containment relative to similar pressure suppression designs.
4. Compartmentalized ECCS systems for physical and flood separation.
5. Three ECCS divisions.
6. Two separate divisions of Hydrogen Igniters.
7. A motor driven feedwater pump in addition to the two turbine driven feedwater pumps.

The CPS IPE program has to date produced several interim reports. These reports, based upon CPS IPE results, have been provided for use to the Operations Training department and the Emergency Planning Organization for generating realistic scenarios for operator training and Emergency Plan drills. These documents,

along with a number of other supporting documents, provide the reference basis for the IPE and are available at CPS.

Insights were also generated during the CPS IPE development. These insights represent an accumulation of observations and calculations that may provide the means to reduce the core damage frequency. Several potential changes were evaluated in accordance with NUMARC 91-04, "Severe Accident Issue Closure Guidelines". However, any commitment for specific action will be reserved until severe accident management program development after completion of the IPE for External Events (IPEEE).

The only open Unresolved Safety Issue (USI) or Generic Safety Issue (GSI) for CPS was USI A-45, "Loss of Decay Heat Removal". The result of this evaluation was that the design of CPS shows no vulnerabilities in this area and this issue should be considered closed by this submittal.

The completion of this CPS IPE report does not represent the end of the CPS IPE. CPS intends to maintain and apply the PRA as a management tool. Specific policies on updates and future uses of the CPS IPE are yet to be determined; however, implementation of the maintenance rule, review of plant modifications, studies to support licensing actions, and reactor SCRAM reduction are expected to be among the uses of the CPS PRA.

THIS PAGE

INTENTIONALLY

LEFT BLANK