

CPS/USAR

CHAPTER 12 RADIATION PROTECTION

TABLE OF CONTENTS

| | | <u>PAGE</u> |
|------------|---|-------------|
| 12.1 | <u>ENSURING THAT OCCUPATIONAL RADIATION EXPOSURES ARE AS LOW AS REASONABLY ACHIEVABLE (ALARA)</u> | 12.1-1 |
| 12.1.1 | Policy Considerations | 12.1-1 |
| 12.1.1.1 | Organizational Structure | 12.1-1 |
| 12.1.1.2 | Personnel Responsibilities | 12.1-1 |
| 12.1.2 | Design Considerations | 12.1-2 |
| 12.1.2.1 | Facility Design Considerations | 12.1-2 |
| 12.1.2.1.1 | Site and Restricted Area | 12.1-2 |
| 12.1.2.1.2 | Plant Access Control | 12.1-2 |
| 12.1.2.1.3 | Controls Within the Radiological Control Boundary | 12.1-3 |
| 12.1.2.1.4 | Radiation Protection Facilities | 12.1-3 |
| 12.1.2.1.5 | Drain Systems | 12.1-3 |
| 12.1.2.1.6 | Ventilation Systems | 12.1-4 |
| 12.1.2.2 | Equipment Design Considerations | 12.1-4 |
| 12.1.2.2.1 | Mechanical Systems Design | 12.1-4 |
| 12.1.2.2.2 | Equipment Layout | 12.1-4 |
| 12.1.2.2.3 | Equipment Design | 12.1-4 |
| 12.1.2.2.4 | Control of Radioactive Fluids and Effluents | 12.1-5 |
| 12.1.2.3 | Design Considerations Based Upon Past Experience | 12.1-5 |
| 12.1.2.4 | Guidance for Designers | 12.1-5 |
| 12.1.2.5 | Design Features to Reduce Maintenance Dose | 12.1-6 |
| 12.1.2.6 | Design Considerations for Decommissioning | 12.1-6 |
| 12.1.2.7 | Design Review | 12.1-6 |
| 12.1.3 | Operational Considerations | 12.1-7 |
| 12.2 | <u>RADIATION SOURCES</u> | 12.2-1 |
| 12.2.1 | Contained Sources | 12.2-1 |
| 12.2.1.1 | Reactor Core Sources | 12.2-1 |
| 12.2.1.2 | Spent Fuel Assembly Sources | 12.2-1 |
| 12.2.1.3 | Reactor Water Sources | 12.2-1 |
| 12.2.1.4 | Reactor Steam Sources | 12.2-2 |
| 12.2.1.5 | Off-Gas Sources | 12.2-2 |
| 12.2.1.6 | Condensate Sources | 12.2-2 |
| 12.2.1.7 | Spent Fuel Pool Water Sources | 12.2-2 |
| 12.2.1.8 | Source from Crud Buildup | 12.2-2 |
| 12.2.1.9 | Radioisotope Inventories in Major Pieces of Equipment | 12.2-3 |
| 12.2.1.10 | Traversing Incore Probe (TIP) System Sources | 12.2-3 |
| 12.2.2 | Airborne Radioactive Material Sources | 12.2-3 |
| 12.2.2.1 | Production of Airborne Sources | 12.2-3 |

CPS/USAR

TABLE OF CONTENTS (Cont'd)

| | | <u>PAGE</u> |
|-------------|--|-------------|
| 12.2.2.2 | Model for Calculating Airborne Concentrations | 12.2-4 |
| 12.2.2.3 | Airborne Sources During Power Operation | 12.2-6 |
| 12.2.2.4 | Airborne Sources During Refueling | 12.2-6 |
| 12.2.2.5 | Sources from Relief Valve Venting | 12.2-7 |
| 12.2.3 | References | 12.2-7 |
| 12.3 | <u>RADIATION PROTECTION DESIGN FEATURES</u> | 12.3-1 |
| 12.3.1 | Facility Design Features | 12.3-1 |
| 12.3.1.1 | Radiation Zones | 12.3-1 |
| 12.3.1.2 | Mechanical System Design Features | 12.3-2 |
| 12.3.1.3 | Equipment Layout Features | 12.3-2 |
| 12.3.1.3.1 | Shielding | 12.3-2 |
| 12.3.1.3.2 | Separation | 12.3-2 |
| 12.3.1.3.3 | Sampling and Instrument Locations | 12.3-3 |
| 12.3.1.3.4 | Skyshine | 12.3-3 |
| 12.3.1.3.5 | Steam Separator and Dryer Transfer | 12.3-3 |
| 12.3.1.4 | Personnel Access | 12.3-3 |
| 12.3.1.4.1 | Labyrinths | 12.3-3 |
| 12.3.1.4.2 | Hatches | 12.3-4 |
| 12.3.1.4.3 | Ladders and Galleries | 12.3-4 |
| 12.3.1.5 | Equipment Removal | 12.3-4 |
| 12.3.1.5.1 | Hatches | 12.3-4 |
| 12.3.1.5.2 | Removable Block Walls | 12.3-4 |
| 12.3.1.5.3 | Cranes and Pull Spaces | 12.3-4 |
| 12.3.1.6 | Remote Operation | 12.3-5 |
| 12.3.1.7 | Radioactive Crud Control | 12.3-5 |
| 12.3.1.7.1 | Material Selection | 12.3-6 |
| 12.3.1.7.2 | Equipment and System Design | 12.3-6 |
| 12.3.1.7.3 | Packaging and Handling Practices | 12.3-7 |
| 12.3.1.7.4 | Cleanup Features | 12.3-7 |
| 12.3.1.8 | Decontamination Facilities | 12.3-7 |
| 12.3.1.8.1 | Coating | 12.3-7 |
| 12.3.1.8.2 | Equipment Decontamination Facilities | 12.3-8 |
| 12.3.1.9 | High-Exposure Risk Operations | 12.3-8 |
| 12.3.1.9.1 | Fuel Transfer | 12.3-8 |
| 12.3.1.9.2 | Inservice Inspection | 12.3-9 |
| 12.3.1.10 | Radiation Protection Facilities | 12.3-9 |
| 12.3.1.10.1 | Radiation Protection Offices | 12.3-9 |
| 12.3.1.10.2 | Access Control Point | 12.3-9 |
| 12.3.1.10.3 | Radchem Laboratories | 12.3-10 |
| 12.3.1.10.4 | Counting Room | 12.3-10 |
| 12.3.1.10.5 | Laundry | 12.3-10 |
| 12.3.1.10.6 | Personnel Decontamination and Change Rooms | 12.3-10 |
| 12.3.1.10.7 | Radiation Protection Instrument Calibration Facility | 12.3-10 |
| 12.3.2 | Shielding | 12.3-10 |
| 12.3.2.1 | Codes and Standards | 12.3-10 |

CPS/USAR

TABLE OF CONTENTS (Cont'd)

| | | <u>PAGE</u> |
|--------------|---|-------------|
| 12.3.2.2 | Design Bases | 12.3-11 |
| 12.3.2.2.1 | Operating Conditions | 12.3-11 |
| 12.3.2.2.2 | Radiation Sources | 12.3-11 |
| 12.3.2.2.3 | Operating Experience | 12.3-11 |
| 12.3.2.3 | Design Criteria | 12.3-11 |
| 12.3.2.4 | Criteria for Penetrations in Shields | 12.3-11 |
| 12.3.2.5 | Shielding Materials | 12.3-12 |
| 12.3.2.6 | Calculational Techniques | 12.3-12 |
| 12.3.2.7 | CPS Shielding Design | 12.3-12 |
| 12.3.2.8 | Design and Evaluation of Drywell Penetrations | 12.3-13 |
| 12.3.3 | Ventilation | 12.3-14 |
| 12.3.3.1 | Design Objectives | 12.3-14 |
| 12.3.3.2 | Design Criteria | 12.3-14 |
| 12.3.3.3 | Special Ventilation Design Features | 12.3-16 |
| 12.3.3.3.1 | Control Room Ventilation | 12.3-16 |
| 12.3.3.3.2 | Drywell Purge System | 12.3-16 |
| 12.3.3.3.3 | Containment Building Ventilation and Purge Systems | 12.3-16 |
| 12.3.3.3.3.1 | Containment Building Ventilation System | 12.3-16 |
| 12.3.3.3.3.2 | Continuous Containment Purge System | 12.3-17 |
| 12.3.3.3.4 | Radwaste Building Ventilation | 12.3-17 |
| 12.3.3.3.5 | Fuel Building Ventilation | 12.3-17 |
| 12.3.3.3.6 | Laboratory System | 12.3-18 |
| 12.3.3.3.7 | Standby Gas Treatment System | 12.3-18 |
| 12.3.3.3.8 | Auxiliary Building Ventilation | 12.3-18 |
| 12.3.4 | Area Radiation and Airborne Radioactivity Monitoring Instrumentation | 12.3-19 |
| 12.3.4.1 | Area Radiation Monitoring Instrumentation | 12.3-19 |
| 12.3.4.1.1 | Area Radiation Monitoring Equipment Design | 12.3-20 |
| 12.3.4.1.1.1 | Energy Dependence | 12.3-20 |
| 12.3.4.1.1.2 | Range | 12.3-20 |
| 12.3.4.1.1.3 | Sensitivity | 12.3-20 |
| 12.3.4.1.1.4 | Setpoints | 12.3-20 |
| 12.3.4.1.1.5 | Power Supply | 12.3-20 |
| 12.3.4.1.1.6 | Calibration | 12.3-20 |
| 12.3.4.1.2 | Area Radiation Monitoring Instrumentation Description | 12.3-21 |
| 12.3.4.1.3 | Functioning of ARM's During and After an Accident | 12.3-21 |
| 12.3.4.2 | Continuous Airborne Radioactivity Monitoring Instrumentation | 12.3-21 |
| 12.3.4.2.1 | Continuous Airborne Radioactivity Monitoring Equipment Design | 12.3-22 |
| 12.3.4.2.1.1 | Detector Types, Ranges, and Alarms | 12.3-22 |
| 12.3.4.2.1.2 | Power Supply | 12.3-22 |
| 12.3.4.2.1.3 | Calibration | 12.3-22 |
| 12.3.4.2.1.4 | Sample Lines | 12.3-22 |
| 12.3.4.2.2 | Continuous Airborne Radioactivity Monitoring Instrumentation System Description | 12.3-22 |
| 12.3.4.2.3 | Criteria for Continuous Airborne Radioactivity Monitoring Locations | 12.3-23 |

CPS/USAR

TABLE OF CONTENTS (Cont'd)

| | | <u>PAGE</u> |
|--------------|---|-------------|
| 12.3.4.2.3.1 | Selection of Locations for Fixed Continuous Airborne Monitoring Locations | 12.3-24 |
| 12.3.4.2.3.2 | Selection of Locations for Portable Continuous Airborne Radioactivity Monitors | 12.3-24 |
| 12.3.4.2.4 | Functioning of CAM's During and After an Accident | 12.3-24 |
| 12.3.4.3 | Special Application Instrumentation | 12.3-25 |
| 12.3.4.3.1 | Fuel Handling Equipment Associated Monitors | 12.3-25 |
| 12.3.4.3.1.1 | Equipment Design | 12.3-25 |
| 12.3.4.4 | Conformance to Specific Regulatory Requirements | 12.3-25 |
| 12.3.4.4.1 | Regulatory Guide 8.2 | 12.3-25 |
| 12.3.4.4.2 | Regulatory Guide 8.8 | 12.3-26 |
| 12.3.4.4.2.1 | Position C.2.G | 12.3-26 |
| 12.3.4.4.2.2 | Position 4B | 12.3-26 |
| 12.3.4.4.3 | Regulatory Guide 8.12 | 12.3-26 |
| 12.3.4.5 | Compliance with Industry Standards | 12.3-26 |
| 12.3.4.5.1 | ANSI N13.1 | 12.3-26 |
| 12.3.4.5.1.1 | Representative Samples | 12.3-26 |
| 12.3.4.5.1.2 | Methods | 12.3-26 |
| 12.3.4.5.1.3 | Validation of Sampling Effectiveness | 12.3-26 |
| 12.3.5 | References | 12.3-27 |
| 12.4 | <u>DOSE ASSESSMENT</u> | 12.4-1 |
| 12.4.1 | Dose Within the Station | 12.4-1 |
| 12.4.1.1 | Dose Rate Criteria | 12.4-1 |
| 12.4.1.2 | Dose from Contained Sources | 12.4-2 |
| 12.4.1.3 | Dose from Airborne Radioactivity Sources | 12.4-2 |
| 12.4.1.3.1 | Dose From Leakage Sources | 12.4-2 |
| 12.4.1.3.2 | Dose From SRV Blowdown Sources | 12.4-2 |
| 12.4.1.4 | Design Improvements | 12.4-3 |
| 12.4.1.4.1 | Modifications Implemented to Reduce Doses | 12.4-3 |
| 12.4.1.4.2 | Engineering Techniques for Reducing Occupational Radiation Exposure | 12.4-4 |
| 12.4.1.4.3 | Mark III Containment and Innovations for Reducing Occupational Radiation Exposure | 12.4-5 |
| 12.4.2 | Annual Dose at the Restricted Area Boundary | 12.4-5 |
| 12.4.2.1 | Dose from Skyshine | 12.4-5 |
| 12.4.2.2 | Dose from Cycled Condensate Storage Tank | 12.4-5 |
| 12.4.2.3 | Dose from Gaseous Effluents | 12.4-6 |
| 12.4.3 | Annual Dose at the Site Boundary | 12.4-6 |
| 12.4.4 | Compliance with Regulatory Guide 8.19 | 12.4-6 |
| 12.4.4.1 | Reactor Operations and Surveillance | 12.4-6 |
| 12.4.4.2 | Routine Maintenance | 12.4-7 |
| 12.4.4.3 | Waste Processing | 12.4-7 |
| 12.4.4.4 | Refueling | 12.4-7 |
| 12.4.4.5 | Inservice Inspection | 12.4-7 |
| 12.4.4.6 | Special Maintenance | 12.4-8 |

CPS/USAR

TABLE OF CONTENTS (Cont'd)

| | | <u>PAGE</u> |
|------------|--|-------------|
| 12.4.5 | References | 12.4-8 |
| 12.5 | <u>RADIATION PROTECTION PROGRAM</u> | 12.5-1 |
| 12.5.1 | Organization | 12.5-1 |
| 12.5.2 | Equipment, Instrumentation, and Facilities | 12.5-1 |
| 12.5.3 | Procedures | 12.5-2 |
| 12.5.3.1 | Radiation Surveys | 12.5-3 |
| 12.5.3.2 | Procedures and Methods Ensuring ALARA | 12.5-3 |
| 12.5.3.2.1 | Refueling | 12.5-3 |
| 12.5.3.2.2 | Inservice Inspection | 12.5-3 |
| 12.5.3.2.3 | Radwaste Handling | 12.5-3 |
| 12.5.3.2.4 | Spent Fuel Handling, Loading, and Shipping | 12.5-4 |
| 12.5.3.2.5 | Normal Operation | 12.5-4 |
| 12.5.3.2.6 | Routine Maintenance | 12.5-4 |
| 12.5.3.2.7 | Sampling | 12.5-4 |
| 12.5.3.2.8 | Calibration | 12.5-4 |
| 12.5.3.3 | Controlling Access | 12.5-4 |
| 12.5.3.4 | Area, Equipment, and Personnel Contamination Control | 12.5-5 |
| 12.5.3.5 | Training Programs | 12.5-5 |
| 12.5.3.6 | Personnel Monitoring | 12.5-6 |
| 12.5.3.6.1 | Personnel External Exposure | 12.5-6 |
| 12.5.3.6.2 | Personnel Internal Exposure | 12.5-6 |
| 12.5.3.7 | Evaluation and Control of Potential Airborne Radioactivity | 12.5-6 |
| 12.5.3.8 | Radioactive Source Control | 12.5-7 |

CPS/USAR

CHAPTER 12 RADIATION PROTECTION

LIST OF TABLES

| <u>NUMBER</u> | <u>TITLE</u> | <u>PAGE</u> |
|---------------|--|-------------|
| 12.2-1 | Basic Reactor and Drywell Data | 12.2-8 |
| 12.2-2 | Spent Fuel Source Spectra per Fuel Assembly | 12.2-11 |
| 12.2-3 | Reactor Water Sources | 12.2-12 |
| 12.2-4 | Coolant Activation Products in Reactor Steam | 12.2-14 |
| 12.2-5 | Design Basis Emission Rate of Noble Gases | 12.2-15 |
| 12.2-6 | Radioisotope Concentrations in the Spent Fuel Pool Water | 12.2-16 |
| 12.2-7 | N-16 Inventory in Equipment Containing Reactor Water and Steam | 12.2-18 |
| 12.2-8 | Radioisotope Inventories in Miscellaneous Equipment | 12.2-19 |
| 12.2-9 | Radwaste Equipment Locations and Source Geometries for Shielding | 12.2-22 |
| 12.2-10 | Design Basis Inventories of Radioactive Nuclides in Major Liquid Waste Subsystem Components with Resin Regeneration | 12.2-23 |
| 12.2-10A | Design Basis Inventories of Radioactive Nuclides in Major Liquid Waste Subsystem Components Without Resin Regeneration | 12.2-26 |
| 12.2-11 | Design Basis Inventory of Radioactive Nuclides in Major Gaseous Waste Subsystem Components | 12.2-29 |
| 12.2-12 | Design Basis Inventories of Radioactive Nuclides in Major Wet Solid Waste Subsystem Components | 12.2-31 |
| 12.2-13 | Airborne Radioactivity Concentration in Plant Areas | 12.2-35 |
| 12.2-14 | Activity Inventories Released to the Suppression Pool from Relief Valves after Scram | 12.2-43 |
| 12.2-15 | Traversing Incore Probe (TIP) System Radiation Levels | 12.2-44 |
| 12.3-1 | Computer Codes Used in Shielding Design | 12.3-28 |
| 12.3-2 | Locations of Fixed Area Radiation Monitors | 12.3-29 |
| 12.3-3 | Continuous Airborne Radioactivity Monitor Channel Characteristics | 12.3-30 |
| 12.3-4 | Locations of Fixed Continuous Airborne Radioactivity Monitors | 12.3-31 |
| 12.3-5 | Deleted | 12.3-32 |
| 12.3-6 | Sample Taps for Use with Portable Continuous Airborne Radioactivity Monitors | 12.3-33 |
| 12.4-1 | Data From Operating BWRs for 1977 | 12.4-9 |
| 12.4.2 | Data From Operating BWRs for 1977: Percentages of Doses by Work Function | 12.4-10 |
| 12.4-3 | Estimates of Occupational Radiation Dose From Contained Sources | 12.4-11 |
| 12.4-4 | Occupational Radiation Dose By Work Functions | 12.4-13 |
| 12.4-5 | Estimates of Occupational Radiation Dose From Airborne Radioactivity | 12.4-14 |
| 12.4-6 | Estimate of Occupational Radiation Dose From A Safety/Relief Valve Blowdown Event | 12.4-15 |

CPS/USAR

CHAPTER 12 RADIATION PROTECTION

LIST OF TABLES

| <u>NUMBER</u> | <u>TITLE</u> | <u>PAGE</u> |
|---------------|---|-------------|
| 12.4-7 | Estimated Annual Doses at the Restricted Area Boundary | 12.4-16 |
| 12.4-8 | Estimated Annual Doses at the Site Boundary | 12.4-17 |
| 12.4-9 | Deleted | 12.4-18 |
| 12.5-1 | Deleted | 12.5-8 |
| 12.5-2 | Portable and Laboratory Technical Equipment and Instrumentation | 12.5-9 |

CPS/USAR

CHAPTER 12 RADIATION PROTECTION

LIST OF FIGURES

| <u>NUMBER</u> | <u>TITLE</u> |
|-------------------------------|---|
| 12.2-1 | Basic Reactor and Drywell Model |
| 12.3-1 through 12.3-29 | Deleted |
| 12.3-30 | Isometric View of the RWCU Filter Demineralizer and Associated Equipment |
| 12.3-31 | Spent Resin Tank and Pump Cubicles |
| 12.3-32 | Isometric View of the Chemical Waste Evaporator |
| 12.3-33 | Charcoal Adsorber Room |
| 12.3-34 | Desiccant Dryer and Regenerator Rooms |
| 12.3-35 | Desirable Entrance Locations |
| 12.3-36 | Typical Design of a Radioactive Tank That Minimizes Crud Pockets |
| 12.3-37 | Layout of the Equipment Decontamination Room and Unit 2 Decon/Change Facility |
| 12.3-38 through 12.3-63 | Deleted |
| 12.3-64 | Typical Filter Package |

CPS/USAR

CHAPTER 12 RADIATION PROTECTION

DRAWINGS CITED IN THIS CHAPTER*

* The listed drawings are included as "General References" only; i.e., refer to the drawings to obtain additional detail or to obtain background information. These drawings are not part of the USAR. They are controlled by the Controlled Documents Program.

| <u>DRAWING*</u> | <u>SUBJECT</u> |
|-----------------|---|
| M01-1101 | Site Development |
| M01-1500 | Radiation Shielding Design - Roof Plan |
| M01-1501 | Radiation Shielding Design - Turbine Building El. 712'-0" |
| M01-1502 | Radiation Shielding Design - Radwaste Building El. 702'-0" |
| M01-1504 | Radiation Shielding Design - Fuel, Containment & Auxiliary Buildings El. 712'-0" & 707'-6" |
| M01-1505 | Radiation Shielding Design - Containment & Diesel Generator Buildings El. 702'-0" & 712'-0" |
| M01-1507 | Radiation Shielding Design - Turbine Building El. 737'-0" |
| M01-1508 | Radiation Shielding Design - Radwaste Building El. 737'-0" |
| M01-1510 | Radiation Shielding Design - Containment & Auxiliary Buildings El. 737'-0" |
| M01-1511 | Radiation Shielding Design - Containment & Diesel Generator Buildings El. 737'-0" |
| M01-1513 | Radiation Shielding Design - Turbine Building El. 762'-0" |
| M01-1514 | Radiation Shielding Design - Radwaste Building El. 762'-0" |
| M01-1516 | Radiation Shielding Design - Fuel, Containment & Auxiliary Buildings El. 755'-0" & 762'-0" |
| M01-1517 | Radiation Shielding Design - Containment & Diesel Generator Buildings El. 762'-0" |
| M01-1519 | Radiation Shielding Design - Turbine Building El. 800'-0" |
| M01-1521 | Radiation Shielding Design - Turbine Building El. 781'-0" |
| M01-1522 | Radiation Shielding Design - Containment Building El. 803'-3" |
| M01-1524 | Radiation Shielding Design - Containment Building El. 800'-0" |
| M01-1526 | Radiation Shielding Design - Containment Building El. 825'-0" |
| M01-1527 | Radiation Shielding Design - Fuel, Containment & Auxiliary Buildings El. 778'-0" & 781'-0" |
| M01-1530 | Radiation Shielding Design - Containment Building El. 828'-3" |
| M01-1531 | Radiation Shielding Design - Radwaste Building El. 720'-0" |
| M01-1532 | Radiation Shielding Design - Control & Diesel Generator Buildings El. 719'-0" |
| M01-1533-2 | Radiation Shielding Design - Fuel, Containment & Auxiliary Buildings N-S Section |
| M05-1037 | Fuel Pool Cooling and Cleanup System |
| M05-1060 | Suppression Pool Cleanup System |
| M05-1076 | Reactor Water Clean-up System |
| S27-1933 | Drywell Wall Developed Elevation Showing Penetrations and Occupancy Area Locations |
| S27-1934 | Drywell Wall Developed Elevation Showing Penetrations and Occupancy Area Locations |

CPS/USAR

CHAPTER 12 - RADIATION PROTECTION

12.1 ENSURING THAT OCCUPATIONAL RADIATION EXPOSURES ARE AS LOW AS REASONABLY ACHIEVABLE (ALARA)

12.1.1 Policy Considerations

It is Exelon's intention to ensure that all aspects of Clinton Power Station (CPS) design and operation are conducted in a manner such that occupational exposure will be "as low as is reasonably achievable" (ALARA). The ALARA commitment is applied to individual and collective (person-rem) exposures. CPS's commitment to ALARA is established and managed by the corporate Radiological Protection Program and implemented through department procedures by responsible individuals. Each individual, supervisor and manager must demonstrate support for this commitment by actively pursuing radiation exposure reduction. The development of the proper attitudes toward, and awareness of, the ALARA policy is accomplished by providing appropriate training for all plant personnel. The program provides for the design review of plant systems, facilities, equipment and modifications to them for incorporation of ALARA principles. All work performed at CPS is required to comply with CPS procedures which are reviewed to ensure that the intentions of ALARA are met. Suggestions to reduce exposure are accepted and reviewed to find ways to reduce exposure, and to assure the CPS ALARA Program involves all station personnel in efforts to minimize radiation exposure.

12.1.1.1 Organizational Structure

The minimum organizational structure of the management individuals having responsibility for ALARA is implemented through station procedures.

12.1.1.2 Personnel Responsibilities

A Site Vice President directs the implementation of the ALARA program and is responsible for its overall effectiveness. The overall ALARA program is the responsibility of the Manager - Clinton Power Station. Responsibility for design and engineering aspects is assigned to the Manager - Nuclear Station Engineering Department (NSED). All Nuclear Program Department Managers and Directors are responsible for assuring the work performed by their departments is accomplished in accordance with ALARA principles and procedures. Each radiation worker is instructed in personal responsibilities for following radiation protection procedures, notifying Radiation Protection personnel of any problems involving radiation or radioactive material, minimizing his/her individual cumulative dose, and making recommendations to accomplish improvements in ALARA procedures and practices.

The designated Radiation Protection Manager is responsible for implementation of all aspects of the Radiological Protection Program. Administrative procedures dealing with ALARA were developed and are reviewed under cognizance of the designated Radiation Protection Manager.

The technical portions of the ALARA program are the responsibility of the designated Radiation Protection Manager normally through an ALARA Coordinator, including:

- a. monitoring design and construction of major modifications for incorporation of ALARA considerations of Regulatory Guides 8.8 and 8.10;
- b. writing implementation procedures for the ALARA program;

CPS/USAR

- c. establishing a suitable CPS occupational dose accounting system;
- d. conducting ALARA reviews for the purpose of identifying potential or actual situations of significant radiation exposures to personnel.

12.1.2 Design Considerations

The objectives of the radiological protection design are the following:

- a. Meeting the requirements set forth in 10 CFR 20 and 10 CFR 50, Appendix A, Criterion 19.
- b. Complying with the guidance given in Regulatory Guides 1.3, 1.5, 1.13, 1.25, 1.69 and 8.8
- c. Complying with industry standards where applicable.

Design goals are not only to meet the requirements of 10CFR, but also to reduce the radiation exposure to plant personnel and the general public to ALARA levels as recommended by Regulatory Guides 8.8 and 8.10. These objectives and goals of the design are realized through the steps described in the following subsections.

12.1.2.1 Facility Design Considerations

Careful consideration is given to achieving ALARA radiation doses through an efficient facility design and plant layout. Given below are some highlights. Further details are given in Subsection 12.3.1.

12.1.2.1.1 Site and Restricted Area

The Clinton Power Station (CPS) site is described in Chapter 1.0 and identified in Drawing M01-1101. It includes all of the cooling lake. The exclusion area falls completely within the site boundary, and the land in the exclusion area is owned by Exelon. The restricted area is described in Subsection 2.1.1.3. The cycled condensate storage tank is located within the protected area boundary.

12.1.2.1.2 Plant Access Control

Personnel access to the plant Radiological Control Area (RCA) is managed by both Protected Area and RCA access control procedures. Entry to the Protected Area occurs through a Main Access Facility or gatehouse where access is controlled by the Station Security Force. Access to the RCA is based upon radiological control criteria (such as training and exposure status).

In the design for the plant RCA, consideration was given to minimizing exposure as well as the spread of contamination in any area of the plant. The objective is to maintain as many of the plant areas free of contamination as is practicable, and to contain contamination within defined boundaries. In particular, the following design considerations are employed for access control:

- a. All general-use parking lots are outside the Protected Area.

CPS/USAR

- b. All Protected Area Access/Egress Facilities are equipped with portal radiation monitors or portable monitoring equipment. All personnel leaving the Protected Area are required (unless exempted by the designated Radiation Protection Manager) to pass through a portal radiation monitor or use portable equipment as a final check to prevent the removal of radioactive material from the Protected Area.
- c. A limited number of RCA access control points are established as the only points of RCA entry and exit. Other access points, which are required for trucks and railcars, are normally closed and used only with the knowledge and concurrence of Radiation Protection supervisory personnel.
- d. Individual exposure information is available at the Radiation Protection Office. Radiological survey data of Radiological Control Areas is available at the Service Building and Radwaste Building access points, for personnel to review upon entering the RCA. Radiation Protection personnel are available to answer any questions personnel may have about specific areas or requirements.
- e. Personnel shall exit the RCA via one of the access control points mentioned in Subparagraph c. Radiation monitoring equipment, either portal radiation monitors or portable monitoring equipment, is used to check each person for radioactive contamination before leaving the RCA.

12.1.2.1.3 Controls Within The Radiological Control Area

a. Personnel Decontamination Facilities

Two personnel decontamination rooms have been provided. One is located in the Radwaste Building near the Machine Shop. This facility will be used as the primary during normal operations. A second facility may be used near the refueling floor access/egress point during major outage activities.

b. Access to High Radiation Areas

Access to High Radiation Areas is controlled in accordance with the Clinton Power Station Technical Specifications, Section 5.7.

12.1.2.1.4 Radiation Protection Facilities

Adequate radiation protection facilities are provided for an efficient radiation protection operation. Major facilities are provided in the service building, radwaste building, and laboratories are provided in the control building. Details are given in Subsection 12.3.1.

12.1.2.1.5 Drain Systems

Floor drains from areas with potential for contamination are collected in drain tanks or sumps through the floor drain system. Similarly, the equipment drains from equipment handling potentially radioactive fluids are also collected through the equipment drain system. Liquid from both the floor drains and the equipment drains is then processed through the liquid radwaste processing system and is either reused or discharged. Traps and seals are provided in the drain piping to maintain ventilation barriers between general access areas and contamination areas.

12.1.2.1.6 Ventilation Systems

The plant ventilation systems are designed to keep any airborne radioactivity away from the general access areas, and to maintain its concentration below the airborne concentration limits defined in 10 CFR 20. Detailed radiation protection features of the ventilation system are given in Subsection 12.3.3.

12.1.2.2 Equipment Design Considerations

12.1.2.2.1 Mechanical Systems Design

Although the prime consideration in a mechanical system design is its safe and efficient operation to fulfill its intended function, consideration is given to the radiological protection aspects in the design of the system. Two examples are noted here. First, in the fuel pool cooling and cleanup system (see Subsection 9.1.3), the filter demineralizers are installed upstream of the heat exchangers, to minimize the radiation levels and potential crud buildup in and near the heat exchangers and associated piping. Second, 100% of the condensate, including the drains from the high-pressure and low-pressure heaters (see Subsection 10.4.7.2), is passed through the condensate polisher units to minimize the radioactive sources in the feedwater stream.

In addition, isolation valves, etc., are provided where practical to avoid dead legs in radioactive streams and incorporate other radiation protection considerations.

12.1.2.2.2 Equipment Layout

All the components belonging to a mechanical system that handles radioactive streams are laid out in close proximity to each other, where practicable. Another consideration in the layout is to avoid routing radioactive pipes through cubicles where it can be avoided. Other details of the equipment layout features, such as separation of high maintenance items from low maintenance items, etc., are given in Subsection 12.3.1.

12.1.2.2.3 Equipment Design

Regulatory Guide 8.8 guidance is followed in designing and specifying equipment that handles radioactive streams. Traditionally high maintenance items such as valves and pumps are selected for long life and ease of maintenance. Tanks are designed to be vertical with conical bottoms and with all the interior corners rounded off to 1/2-inch radius in order to minimize crud pockets. Flushing connections are provided for the tanks and other major pieces of equipment for decontamination prior to maintenance.

In the laboratories, laundry, and decontamination rooms, the sinks and counter tops are specified to be made of stainless steel or other smooth, non-porous material for ease of decontamination. For the same purpose, walls and floors are coated to a smooth finish in plant areas where contamination is possible.

Processing liquid radwaste and the processing and drumming of radwaste sludges and slurries are done remotely, as are spent fuel transfer and storage operations.

CPS/USAR

12.1.2.2.4 Control of Radioactive Fluids and Effluents

Radioactive process fluid streams are processed by the liquid radwaste processing systems and reused to the extent possible. Liquid radwaste is batch sampled and analyzed prior to discharge into the environment and the effluent is continuously monitored during discharge.

12.1.2.3 Design Considerations Based Upon Past Experience

History and data of radiation exposure at the operating BWR's is reported in "Occupational Radiation Exposure at Light Water Cooled Power Reactors 1969 - 1975," NRC Publication NUREG-0109. That information, supplemented by information received through frequent conversations with personnel from utilities with operating BWR's and PWR's, forms the basis for many improvements in the CPS design, aimed towards attaining ALARA occupational doses. Past experience is utilized specifically in areas listed in the following and in Subsection 12.1.2.4:

- a. Consideration is given in the selection of equipment to the prior history of its failure and ease of maintenance.
- b. Shielding is added where experience has shown that it is necessary for protection from radioactive crud buildup and other sources of radiation.
- c. Sufficient equipment decontamination areas are provided to avoid delays and congestion.
- d. Improved radiation protection, personnel decontamination, and laboratory facilities are provided.

12.1.2.4 Guidance for Designers

ALARA design guidance is given to the individual designers by several methods, including the following:

- a. incorporation of principles in formal training lectures;
- b. participation of professionals competent in radiation protection in regular project team meetings;
- c. distribution of copies of federal regulations, NRC regulatory guides, industry standards and documents to individuals for their use, as needed;
- d. distribution of design criteria documents specifically prepared for the purpose of ALARA implementation, by personnel competent in radiation protection;
- e. review of mechanical, electrical and structural criteria by competent professionals to assure that ALARA principles and requirements are incorporated;
- f. providing designers with design information (based on analysis and operational feedback data) to permit proper and improved designs;
- g. schedule reviews of drawings and specification documents to assure incorporation of ALARA principles and requirements; and

CPS/USAR

- h. participation of radiation protection personnel in safety reviews of systems, equipment and facility designs, and making recommendations to correct deficiencies in areas of non-compliance to implement ALARA.

Regulatory Guide 8.8 is used as guidance in the above processes.

12.1.2.5 Design Features to Reduce Maintenance Dose

Several features are added to the CPS design specifically to reduce the maintenance dose, which past experience indicates has been a significant source of personnel exposure. The following are examples of such features:

- a. Separation of equipment: to the extent practicable, each piece of radioactive equipment is separately located in its own cubicle, thus providing shielding and ventilation isolation from other radioactive equipment. Special care is taken to shield the high maintenance items such as pumps and valves from associated tanks. Details are given in Subsection 12.3.1.
- b. Temporary shielding: where space limitations do not allow housing the equipment in separate cubicles, either a shadow shield is erected between the equipment, or sufficient room is provided for temporary shielding.
- c. Redundant equipment: where past experience shows that a piece of equipment requires frequent maintenance, redundant equipment is provided. This serves both to prevent the disruption of plant operation and to reduce the need for hasty repairs, thus allowing more time for planning of maintenance and decontamination. Examples of such redundant equipment at CPS are the reactor water cleanup heat exchangers and the radwaste pumps.
- d. Flushing connections are provided where practicable for on-location decontamination of equipment.
- e. Equipment removal: unmortared block wall sections, built by stacking loose concrete blocks together supported by metal gratings, are provided for equipment removal. This design reduces the time required for equipment removal.

12.1.2.6 Design Considerations for Decommissioning

The various design considerations discussed in this Section 12.1.2, and Section 12.3.1 are applicable to and helpful in maintaining doses ALARA during decommissioning. Of particular interest for the decommissioning considerations are the design features discussed in Sections 12.1.2.5, 12.3.1.2, 12.3.1.3, 12.3.1.4, 12.3.1.5, 12.3.1.6, 12.3.1.7, and 12.3.1.8.

12.1.2.7 Design Review

The CPS design has been reviewed in every major phase by competent reviewers, consisting of people with nuclear power station design experience and certified health physicists. IPs personnel with prior experience in plant operation and design have also participated in the design reviews.

CPS/USAR

The design review procedure has involved independent detailed review of different design aspects such as shielding, radiation monitoring, radiation protection, ventilation and intermittent operations by reviewers who have not contributed significantly to the design. After the independent review, design review meetings have been held to resolve the reviewers' comments and seek solutions for any areas of concern.

12.1.3 Operational Considerations

The designated Radiation Protection Manager is responsible for developing detailed plans and procedures to ensure that occupational radiation exposures are ALARA. Designs are reviewed with the intention of further reducing dose rates, and Radiation Protection personnel routinely explore means to reduce exposures. When it is shown that the radiation exposure is unavoidable or the cost of reducing radiation exposure is unreasonable in comparison with the expected benefit, then by definition the exposure is ALARA. The same review process also applies to review of procedures. The impact of operational requirements is reflected in the design considerations described in Subsection 12.1.2 and the radiation protection design features described in Subsection 12.3.1. Regulatory Guides 8.8 and 8.10 are consulted for guidance on operational considerations.

Operating procedures and techniques which deal with systems that contain, collect, store or transport radioactive liquids, gases, and solids have been given ALARA consideration when applicable. These procedures and techniques, as initially formulated, draw on the operational experience of CPS operators and other BWR power stations. ALARA Program effectiveness will be determined by evaluation of radiation work permits and other radiological performance indicators and as part of the periodic Radiological Protection Program audit. Subsection 12.5.3.2 describes the means for planning and developing procedures for certain radiation-exposure-related operations.

Person-rem tracking will be performed using station procedures which control work within Radiological Control Areas. In addition to these procedures, CPS has in place programs which address person-rem tracking, post-maintenance reviews and provides the criteria for a management review of exposure related to maintenance activities.

CPS also utilizes Job History packages, which includes previous post-maintenance reviews, as an aid in the planning of maintenance activities.

The use of secondary dosimeters (e.g., self-reading pocket dosimeters or electronic dosimeters) is implemented by station procedures (Q&R 471.05).

12.2 RADIATION SOURCES

Radiation sources reported in this section form the basis of the design of shielding and the radiological protection aspects of ventilation and instrument systems. The radiation sources reported are conservative and are generally not exceeded either during normal plant operation or anticipated abnormal occurrences.

The radiation sources reported in the ANSI Standard N237, which are also built into the BWR-GALE Code (Subsection 11.2.4), have been used in calculating the "expected" radioactivity releases from the station, as reported in Chapter 11. The sources reported in this section are higher in magnitude than the ANSI N237 sources. Thus, Clinton's shielding and radiological protection design is more conservative than it would have been if based upon the N237 sources.

12.2.1 Contained Sources

The basic data needed for determining the contained sources of radiation is taken from Reference 1. The following subsections give the bases and magnitudes of various distinct types of contained sources.

12.2.1.1 Reactor Core Sources

The licensed thermal power level of the CPS reactor is 3473 MW. Details of the fuel assemblies, core structure and uranium enrichment are given in Chapter 4. The basic reactor model for source evaluation appears in Figure 12.2-1, while the geometric parameters, material densities and typical core power distributions are given in Table 12.2-1.

The gamma dose rate and the fast neutron (>1 MeV) flux outside the reactor shield wall at the core midplane are determined, using the ANISN computer code (Reference 2), to be 54 R/hr and 2.8×10^5 n/cm²-sec, respectively, with the reactor operating at the licensed power level.

12.2.1.2 Spent Fuel Assembly Sources

Table 12.2-2 gives the spectra of the radioactive sources in one fuel assembly, both with zero-time decay and after decay of 1 day. These sources are calculated using the RIBD subroutine of the ISOSHLD computer code (Reference 3) and assuming that the fuel assembly has been in the core for 3 1/3 years at full-power operation. The sources with 1-day decay are used in designing shielding for the fuel transfer and storage operations.

12.2.1.3 Reactor Water Sources

Reactor water becomes radioactive through its own activation, the leakage of fission products from defective fuel rods, and the addition of products of activation of impurities and structural components (noncoolant material). All the radioisotopes of significance thus added to the primary coolant are listed in Table 12.2-3. The data given here are taken from Reference 1 and are based upon measurements taken at operating plants over the years.

The values given in Table 12.2-3 pertain to equilibrium conditions at full-power operation with the reactor water cleanup (RWCU) system working at full capacity. After reactor shutdown, the activation process ceases, and the leakage rate of fission products from the fuel changes. The prominent effect is that the short-lived activation products, such as N-16 ($t_{1/2} = 7.13$ sec), die

out. The fission product balance will also change, and the concentrations will decrease. However, a conservative assumption is made in the shielding design of systems such as residual heat removal (RHR) that the concentrations of fission and noncoolant activation products remain unchanged.

12.2.1.4 Reactor Steam Sources

Reactor steam becomes radioactive through the same sources as does reactor water. The concentrations of isotopes are different from those in reactor water and depend upon the carryover factors from liquid to vapor phase. The carryover factor for halogens (fission products) is less than 2%, and that for other fission and noncoolant activation products is less than 0.1%. The coolant activation product concentrations in steam and their release rates are given in Table 12.2-4.

12.2.1.5 Off-Gas Sources

Noble gases, which are products of nuclear fission, leak out of defective fuel rods and leave the vessel along with steam. They separate from the latter in the condenser and are then routed to the off-gas treatment system along with other noncondensable gases. The design-basis radioactivity of the noble gases released from the fuel is given in Table 12.2-5 for various decay times. A fraction of the halogen content of the reactor steam also accompanies the off-gas. This fraction of halogens is estimated to be (1/200) of the reactor steam content.

12.2.1.6 Condensate Sources

The radioactive source concentrations in the condensate are the same as those in reactor steam by weight, except for the noble gases, which are not retained in the condensate. The condensate is held up in the condenser hotwell for more than 2 minutes. This holdup time allows N-16 and other short-lived isotopes to decay to insignificant activity. The longer-lived isotopes form the significant part of the source.

12.2.1.7 Spent Fuel Pool Water Sources

Leakage from spent fuel assemblies stored in the pool and cleanup of water through a filter demineralizer result in an equilibrium concentration of radioisotopes in the pool water. Design-basis values of such concentrations are given in Table 12.2-6.

12.2.1.8 Source From Crud Buildup

Crud buildup occurs in all systems that handle radioactive fluids. Since no theoretical model is available that can predict the crud buildup, data from operating nuclear plants, with some extrapolation, forms the basis of design.

The data available from operating plants are almost always in the form of contact dose rates on equipment in which crud has accumulated. The following data from Dresden Nuclear Power Station and Quad-Cities station are typical of such equipment and systems.

CPS/USAR

| Component | Contact Dose Rate, mrem/hr |
|-----------------------------------|-------------------------------|
| RHR heat exchanger | 120-2,000 |
| RHR piping | 100-5,000 |
| Fuel pool heat exchanger | 120-2,000 |
| Fuel pool piping | 60-150 |
| Reactor building equipment drains | 100-400 |
| Strainers | to 10,000 |

The high values occur at crud traps (pipe elbows, pipe reducers, etc.) and the data are for 2 to 3 years of operation. Some of the values may also include standing radioactive water.

12.2.1.9 Radioisotope Inventories in Major Pieces of Equipment

Tables 12.2-7 and 12.2-8 give the design-basis radioisotope inventories for major equipment other than radwaste handling equipment. Table 12.2-7 lists only N-16 inventories for those components in which the N-16 contribution to the dose rate dominates the total dose rate. Table 12.2-8 lists the inventories for components which contain no significant amount of N-16. These tables also give the locations and source geometries used in shielding calculations for the components listed.

Table 12.2-9 gives locations and source geometries for liquid, gaseous, and solid radwaste handling equipment. The source inventories for these components are given in Tables 12.2-10, 12.2-11, and 12.2-12 respectively.

12.2.1.10 Traversing Incore Probe (TIP) System Sources

The TIP system is discussed in Subsection 7.7.1.6. There are two distinct sources of radiation associated with the TIP system, namely, the detector and the part of the drive cable which enters the reactor vessel. The radiation sources are generated through the fission of the U-235 contained in the detector and the neutron activation of the detector housing and the cable. The sources depend upon the material compositions of the components, neutron flux, activation time, and the decay time. The material compositions and the radiation levels from the sources at several decay times are presented in Table 12.2-15. The radiation levels (and not the source strengths of individual nuclides) are provided here for the convenience of presentation and use.

12.2.2 Airborne Radioactive Material Sources

Airborne radioactive source determination is based upon certain conservative assumptions and experience at operating plants.

12.2.2.1 Production of Airborne Sources

Design efforts are directed towards keeping contained all the radioactive material, whether it is in a solid, liquid or gaseous form. However, the unavoidable leaks from process systems and some processes of refueling and decontamination lead to airborne radioactivity.

CPS/USAR

Leakage of radioactive gases leads directly to airborne activity. Leakage of liquids leads to airborne radioactivity through evaporation and suspension in air, the extent of which depends upon the temperature and pressure of the fluid. Water under high pressure, for example, flashes to steam and can result in high airborne activity, whereas water at approximately room temperature and pressure leads to low airborne activity through evaporation. This phenomenon is expressed in terms of a partition factor, which is discussed in Subsection 12.2.2.2.

Radioactive or contaminated solid materials usually do not lead to airborne sources, unless they are exposed to elevated temperatures or affected by mechanical action. Airborne sources are produced, for example, from solid crud deposited on the vessel head and internals, when they are allowed to dry up.

12.2.2.2 Model for Calculating Airborne Concentrations

The isotopic airborne concentration in a room is a function of the initial airborne concentration in air being supplied, the air flow rate, the room volume, total leakage rate of radioactive material, concentration of isotopes in the leaking material and the partition factors (fraction of the liquid concentration that is released to air). The differential equation for the isotope inventory in the room may be written as follows, assuming complete mixing:

$$\frac{dS}{dt} + S + \frac{SF}{V} = A + \sum_i (LIP)_i$$

This leads to the airborne concentration in the room at equilibrium to be:

$$C = \frac{S}{VK_1} = \frac{A + \sum_i (LIP)_i}{(V + FK_2) K_1}$$

Where:

- C = room airborne concentration, $\mu\text{Ci}/\text{cm}^3$
- S = isotope inventory in the room at equilibrium, μCi ;
- V = room volume, ft^3 ;
- K_1 = conversion factor, $2.83 \times 10^4 \text{ cm}^3/\text{ft}^3$;
- A = rate of isotope entry via the incoming air, $\mu\text{Ci}/\text{sec}$;
- i = number of leak paths in the room;
- L = leak rate for each path, g/sec ;
- I = isotope concentration in each leak path, $\mu\text{Ci}/\text{g}$;
- P = partition factor;
- λ = decay constant of the isotope, sec^{-1} ;

CPS/USAR

F = air flow rate through the room, ft³/min; and

K₂ = conversion factor, $\frac{1}{60 \text{ sec/min.}}$

Room volume can be neglected in most cases (it is important only for isotopes with short half lives and large room volumes).

Activity of incoming air, A, can be excluded from the formula because in the areas which have been considered there is no ventilation ganging, or supplied air is clean.

Leak rate, L, for each leak path is represented by an estimated overall release rate for each room or area. Applicable release rates are as follows:

| SOURCE | LEAK RATE |
|-----------------------|---|
| Off-gas sources | 1.25 cm ³ /sec |
| Drywell steam | 252 g/sec (4.0 gpm) (used for drywell purge) |
| Water and steam | 1.25 g/sec (0.02 gpm) |
| Fuel pool evaporation | 63 g/sec (1 gpm) (cont. bldg. during refueling) |
| High-level lab | 0.5 g/sec (.008 gpm) |
| Radchem lab | 0.1 g/sec (.0016 gpm) |
| Hot laundry | 0.1 g/sec (.0016 gpm) |

Isotopic concentrations in the leaking fluid, I in the above equation, are derived from source terms in reactor water (Table 12.2-3) and noble gas emission rates given in Table 12.2-5. Isotopes with an insignificant inhalation hazard potential were eliminated from the list. That is, those with a short half-life were eliminated (<1 min), as well as those with a low hazard index (product of DAC and concentration <0.01 x max. value). Concentrations in reactor steam were obtained as discussed in Subsection 12.2.1.4.

Concentrations in releases in the radchem lab, the high-level lab, and the hot laundry are assumed to be the same as in reactor water. Source terms in the fuel pool for the primary containment during refueling were obtained from Table 12.2-6. Sources terms in the fuel pool for the primary containment during power operation were based on the activity in the suppression pool water. The sources for the capping station were obtained from activity in the sludge tank, given in Table 12.2-12. The source terms for the equipment drain stream are given in Table 11.2-1. The chemical waste system source terms were obtained from Table 11.2-1. The source terms for the condensate filter and condensate demineralizer stream are given in Table 12.2-8. The source terms for the radwaste demineralizer are given in Table 12.2-10. The source terms for the floor drain stream are given in Table 11.2-1.

Partition factors, P, in the above equation, are as follows:

| SOURCE | PARTITION FACTOR (P) |
|---|----------------------|
| Noble gases | 1.0 |
| Iodines and N-16 in high-energy fluids (RWCU, RHR, RCIC cubicles) | 0.1 |

CPS/USAR

| | |
|--|--------|
| Iodines and particulates in low-energy fluids (cubicles and areas, unless otherwise noted) | 0.001 |
| Iodines and particulates in resins (demineralizer valve aisle) | 0.0001 |
| Iodines, particulates and noble gas from steam to air (drywell and condenser cavity) | 1.0 |

Exhaust air flow rates, F in the above equation, were obtained from the HVAC P&ID's given in Chapter 9.

12.2.2.3 Airborne Sources During Power Operation

Design criteria and means to control and minimize airborne sources in plant areas are described in Subsection 12.3.3. One major contributor of airborne sources, viz., the vents from tanks and sumps, is eliminated at CPS by connecting the vents through hard pipes to the ventilation exhaust ducts where practical and will not conflict with other safety concerns.

The general access areas of the plant are not likely to contain airborne radioactive sources under normal ventilation system operation, since (a) the air supply for these areas is taken from outside, (b) the potential for radioactive leaks has been minimized, (c) air is directed from the general access areas to the potentially contaminated cubicles. Very minor airborne contamination in general access areas can be expected when the doors to the contaminated cubicles are opened for access. Airborne contamination can also be expected for a short time when there is some failure of the ventilation system. Minor airborne activity can also be expected in equipment decontamination and hot laboratory areas. Table 12.2-13 lists calculated airborne activity concentrations in various representative plant areas during normal operation.

The cycled condensate storage tank, which receives potentially contaminated water, is located inside of a containment tank within the station Protected Area fence. The airborne radioactivity caused by this tank is greatly diluted in the outside environment, and hence is of no significance for personnel exposures. The RCIC storage tank is located inside the protected area fence and is surrounded by a dike.

12.2.2.4 Airborne Sources During Refueling

Airborne radioactivity in the CPS containment during refueling is expected to be a moderate risk where it can come from hot water in the reactor cavity, and flaking of cobalt oxides from the dryer and separator when their surfaces are allowed to dry. Other potential airborne sources are vessel head venting and fuel movement.

The potential airborne sources in the CPS Mark III Containment will be manageable because of the following design features:

- a. The steam dryer and separator will be out of water for only a short time, as explained in Subsection 12.3.1.3.5.
- b. Provisions are in place to ensure the dryer and separator will be kept moist if transfer sequence is interrupted

CPS/USAR

- c. The fuel pool cooling system has a 200% capacity.
- d. The refueling pool area ventilation system is designed to sweep air from the pool surface and keep potential airborne contamination away from the occupied areas.
- e. The vessel head vent may be connected to the drywell purge system prior to the removal of the head as described in Subsection 9.4.7.2; thus release of airborne contaminants from the vessel to the occupied areas are kept to a minimum. (Q&R 471.07)

12.2.2.5 Sources from Relief Valve Venting

Varying quantities of radioisotopes are released to the suppression pool with the venting of the relief valves. The highest amount of sources are released during a scram from full power. The time history of release of I-131 and Xe-133 to the suppression pool following a scram is given in Table 12.2-14.

Provisions are made to remove the radioisotopes, halogens in particular, from the suppression pool water to minimize their release to the containment atmosphere. For this purpose, the suppression pool water is cleaned by circulating it through one or more fuel pool filter demineralizers or a condensate polisher as needed (see Drawing M05-1060).

12.2.3 References

1. Radiation Sources, General Electric Company Document No. 22A 2703R, Rev. 6 (CPS Master Parts List No. A62-4100).
2. W. W. Engle, Jr., "A Users Manual for ANISN, A One Dimensional Discrete-Ordinates Transport Code With Anisotropic Scattering, " K-1693, Union Carbide Corporation, Nuclear Division, March 30, 1967.
3. R. L. Engle, J. Greenborg, and M. M. Hendrickson, "ISOSHLD". A computer Code for General-Purpose Isotope Shielding Analysis," BNWL-236, Pacific Northwest Laboratory, Richland, Washington, June 1966; Supplement 1, March 1967; Supplement 2, April 1969.

CPS/USAR

TABLE 12.2-1
BASIC REACTOR AND DRYWELL DATA*

A. PHYSICAL DIMENSIONS

| RADII | | INCHES |
|------------|---|--------|
| 1. | Core Equivalent Radius | 84.56 |
| 2. | Inside Shroud Radius | 91.00 |
| 3. | Outside Shroud Radius | 93.00 |
| 4. | Inside Vessel Radius | 109.00 |
| 5. | Outside Vessel Radius | 114.41 |
| 6. | Outside Vessel Radius-reinforced | 114.81 |
| 7. | Shroud Head Inside Radius | 176.00 |
| 8. | Vessel Top Head Inside Radius | 109.00 |
| 9. | Vessel Bottom Head Inside Radius | 117.25 |
| 32. | Reactor Shield Wall Inside Radius | 155.00 |
| 33. | Reactor Shield Wall Outside Radius | 179.00 |
| | Reactor Shield Wall Inner Liner Thickness | 1.50 |
| | Reactor Shield Wall Outer Liner Thickness | 1.50 |
| 34. | Drywell Wall Inside Radius | 414.00 |
| 35. | Drywell Wall Outside Radius | 474.00 |
| ELEVATIONS | | INCHES |
| 10. | Outside of Vessel Bottom Head | -8.77 |
| 11. | Inside of Vessel Bottom Head | -2.09 |
| 12. | Vessel Bottom Head Tangent | 115.16 |
| 13. | Bottom of Core Support Plate | 197.63 |
| 14. | Top of Core Support Plate | 199.63 |
| 15. | Bottom of Active Fuel | 208.56 |
| 16. | Top of Reinforced Vessel Wall | 202.09 |
| 17. | Top of Active Fuel | 358.56 |
| 18. | Bottom of Top Guide | 366.38 |
| 19. | Top of Fuel Channel | 372.94 |
| 20. | Shroud Head Tangent | 420.22 |

* See Figure 12.2-1 for locations and regions.

CPS/USAR

TABLE 12.2-1 (Cont'd)

| ELEVATIONS | | INCHES |
|------------|--------------------------------|--------|
| 21. | Inside of Shroud Head | 445.57 |
| 22. | Outside of Shroud Head | 447.57 |
| 23. | Normal Vessel Water Level | 557.40 |
| 24. | Top of Steam Dryer | 713.13 |
| 25. | Vessel Top Head Tangent | 722.75 |
| 26. | Inside of Vessel Top Head | 831.75 |
| 27. | Outside of Vessel Top Head | 834.53 |
| 28. | Core Midplane | 283.56 |
| 29. | Top of the Reactor Shield Wall | 600.50 |
| 30. | Drywell Head at Centerline | 880.00 |
| 31. | Water Level in Refueling Pool | 999.00 |

B. MATERIAL DENSITY
(grams/cm³ of region volume)

| REGION | COOLANT | UO2 | ZIRCALLOY | 304-STAINLESS |
|--------|---------|-------|-----------|---------------|
| A | 0.740 | 0.0 | 0.000 | 0.178 |
| B | 0.338 | 0.0 | 0.000 | 4.349 |
| C | 0.318 | 2.334 | 0.978 | 0.056 |
| C-1 | 0.597 | 0.0 | 0.166 | 1.697 |
| C-2 | 0.234 | 0.0 | 1.099 | 0.255 |
| D | 0.240 | 0.0 | 1.004 | 1.209 |
| E | 0.390 | 0.0 | 0.000 | 0.000 |
| F | 0.669 | 0.0 | 0.000 | 0.200 |
| G | 0.036 | 0.0 | 0.000 | 0.000 |
| H | 0.74 | 0.0 | 0.000 | 0.000 |
| I | 0.74 | 0.0 | 0.000 | 0.260 |

CPS/USAR

TABLE 12.2-1 (Cont'd)

C.TYPICAL CORE POWER DISTRIBUTIONS

| RADIAL POWER DISTRIBUTION | | AXIAL POWER DISTRIBUTION (typical end-of-life) | |
|---------------------------|----------------|---|----------------|
| % OF EQUIVALENT RADIUS | RELATIVE POWER | ELEVATION (in.) | RELATIVE POWER |
| 0.0 | 1.200 | -75 | 0.343 |
| 20.0 | 1.200 | -68 | 0.755 |
| 35.0 | 1.190 | -60 | 1.055 |
| 50.0 | 1.170 | -48 | 1.190 |
| 60.0 | 1.150 | -36 | 1.200 |
| 70.0 | 1.120 | -24 | 1.190 |
| 80.0 | 1.050 | -12 | 1.170 |
| 85.0 | 0.995 | 0 | 1.155 |
| 90.0 | 0.778 | 12 | 1.140 |
| 92.5 | 0.590 | 24 | 1.105 |
| 95.0 | 0.430 | 36 | 1.055 |
| 97.0 | 0.375 | 48 | 0.945 |
| 98.0 | 0.395 | 60 | 0.715 |
| 99.0 | 0.432 | 68 | 0.462 |
| 100.0 | 0.518 | 75 | 0.212 |

D.REACTOR THERMAL POWER

3473 MW

E.AVERAGE POWER DENSITY

62.9 W/cm³

CPS/USAR

TABLE 12.2-2
SPENT FUEL SOURCE SPECTRA PER FUEL ASSEMBLY

| GROUP AVERAGE ENERGY (MeV) | TOTAL GROUP PRODUCTION RATE (photons/sec) | |
|----------------------------------|--|-------------|
| | NO DECAY | 1-DAY DECAY |
| 1.500-02* | 3.437+17 | 2.526+16 |
| 2.500-02 | 9.984+16 | 1.482+16 |
| 3.500-02 | 7.990+16 | 2.148+16 |
| 4.500-02 | 4.244+16 | 6.586+15 |
| 5.500-02 | 3.267+16 | 4.911+15 |
| 6.500-02 | 2.445+16 | 1.922+15 |
| 7.500-02 | 2.520+16 | 1.577+15 |
| 8.500-02 | 2.796+16 | 6.944+15 |
| 9.500-02 | 5.820+16 | 4.528+15 |
| 1.500-01 | 1.471+17 | 2.347+16 |
| 2.500-01 | 1.147+17 | 1.846+16 |
| 3.500-01 | 9.806+16 | 1.259+16 |
| 4.750-01 | 1.477+17 | 3.113+16 |
| 6.500-01 | 1.646+17 | 4.514+16 |
| 8.250-01 | 1.145+17 | 3.418+16 |
| 1.000+00 | 5.578+16 | 4.980+15 |
| 1.225+00 | 5.955+16 | 3.467+15 |
| 1.475+00 | 6.804+16 | 1.384+16 |
| 1.700+00 | 1.899+16 | 3.567+14 |
| 1.900+00 | 1.046+16 | 5.998+14 |
| 2.100+00 | 1.375+16 | 2.844+14 |
| 2.300+00 | 7.265+15 | 1.267+14 |
| 2.500+00 | 8.426+15 | 4.385+14 |
| 2.700+00 | 4.185+15 | 3.463+12 |
| 3.000+00 | 7.835+15 | 1.436+13 |
| 6.143+00 | 3.407+15 | 3.644+10 |
| 7.112+00 | 0.000 | 0.000 |
| TOTAL | 1.779+18 | 2.771+17 |

* 1.500-2 = 1.500 x 10⁻²

CPS/USAR

TABLE 12.2-3
REACTOR WATER SOURCES

A. REACTOR WATER - COOLANT ACTIVATION PRODUCTS
(equilibrium values - entering recirculation lines)

| <u>ISOTOPE</u> | <u>HALF LIFE</u> | <u>CONCENTRATION</u> ($\mu\text{Ci/g}$) |
|----------------|------------------|--|
| N-13 | 10 min | 7.1 - 2 * |
| N-16 | 7.1 sec | 3.5 + 1 |
| N-17 | 4.1 sec | 1.3 - 2 |
| F-18 | 110 min | 4.8 - 2 |
| O-19 | 26.8 sec | 2.7 |
| TOTAL | | 3.8 + 1 |

B. REACTOR WATER - NONCOOLANT ACTIVATION PRODUCTS

| <u>ISOTOPE</u> | <u>HALF LIFE</u> | <u>CONCENTRATION</u> ($\mu\text{Ci/g}$) |
|----------------|------------------|--|
| Na-24 | 15 hr | 2.0 - 3 |
| P-32 | 14.3 day | 2.0 - 5 |
| Cr-51 | 27.8 day | 5.0 - 4 |
| Mn-54 | 313 day | 4.0 - 5 |
| Mn-56 | 2.6 hr | 5.0 - 2 |
| Co-58 | 71.4 day | 5.0 - 3 |
| Co-60 | 5.3 yr | 5.0 - 4 |
| Fe-59 | 45 day | 8.0 - 5 |
| Ni-65 | 2.6 hr | 3.0 - 4 |
| Zn-65 | 244 day | 2.0 - 6 |
| Zn-69m | 13.7 hr | 3.0 - 5 |
| Ag-110m | 253 day | 6.0 - 5 |
| W-187 | 23.9 hr | 3.0 - 3 |
| TOTAL | | 6.2 - 2 |

C. DESIGN-BASIS REACTOR WATER FISSION PRODUCTS - HALOGENS

| <u>ISOTOPE</u> | <u>HALF LIFE</u> | <u>CONCENTRATION</u> ($\mu\text{Ci/g}$) |
|----------------|------------------|--|
| Br-83 | 2.4 hr | 1.7 - 2 |
| Br-84 | 31.8 min | 3.5 - 2 |
| Br-85 | 3.0 min | 2.2 - 2 |
| I-131 | 8 day | 1.5 - 2 |
| I-132 | 2.3 hr | 1.5 - 1 |
| I-133 | 21 hr | 1.0 - 1 |
| I-134 | 52.8 min | 3.0 - 1 |
| I-135 | 6.7 hr | 1.5 - 1 |
| TOTAL | | 8.0 - 1 |

* (7.1 - 2 = 7.1×10^{-2})

CPS/USAR

TABLE 12.2-3 (Cont'd)

D. DESIGN-BASIS REACTOR WATER FISSION PRODUCTS - OTHER ISOTOPES

| ISOTOPE | HALF LIFE | CONCENTRATION (μ Ci/g) |
|---------|-----------|--------------------------------|
| Sr-89 | 52 day | 3.3 - 3 |
| Sr-90 | 27.7 yr | 2.5 - 4 |
| Sr-91 | 9.7 hr | 8.1 - 2 |
| Sr-92 | 2.7 hr | 1.4 - 1 |
| Zr-95 | 65 day | 4.3 - 5 |
| Zr-97 | 17 hr | 3.6 - 5 |
| Nb-95 | 35 day | 4.5 - 5 |
| Mo-99 | 67 hr | 2.5 - 2 |
| Tc-99m | 6 hr | 9.4 - 2 |
| Tc-101 | 14 min | 2.0 - 1 |
| Ru-103 | 39.6 day | 2.1 - 5 |
| Ru-106 | 367 day | 2.8 - 6 |
| Te-129m | 34 day | 3.7 - 4 |
| Te-132 | 78 hr | 1.5 - 2 |
| Cs-134 | | 1.7 - 4 |
| Cs-136 | | 1.1 - 4 |
| Cs-137 | 30 yr | 2.6 - 4 |
| Cs-138 | 32.2 min | 2.5 - 1 |
| Ba-139 | 82.9 min | 2.0 - 1 |
| Ba-140 | 12.8 day | 9.5 - 3 |
| Ba-141 | 18 min | 2.4 - 1 |
| Ba-142 | 11 min | 2.3 - 1 |
| Ce-141 | 32.5 day | 4.3 - 5 |
| Ce-143 | 33 hr | 3.9 - 5 |
| Ce-144 | 284 day | 3.8 - 5 |
| Pr-143 | 13.6 day | 4.1 - 5 |
| Nd-147 | 11.1 day | 1.5 - 5 |
| Np-239 | 235 day | 2.6 - 1 |
| TOTAL | | <u>1.7 + 0</u> |

CPS/USAR

TABLE 12.2-4
COOLANT ACTIVATION PRODUCTS IN REACTOR STEAM**

| ISOTOPE | HALF LIFE | CONCENTRATION ($\mu\text{Ci/g}$) | RELEASE RATE ($\mu\text{Ci/sec}$) |
|---------|-----------|---------------------------------------|--|
| N-13 | 10 min | 1.5 - 3 | 2.4 + 3 |
| N-16 | 7.1 sec | 5.0 + 1** | 8.2 + 7** |
| N-17 | 4.1 sec | 3.5 - 2 | 5.7 + 4 |
| F-18 | 110 min | 4.4 - 4 | 7.2 + 2 |
| O-19 | 26.8 sec | 7.8 - 1 | 1.2 + 6 |

* The steam also carries the following sources:

- a. 100% of noble gases from Table 12.2-5,
- b. 2% of halogens from Table 12.2-3 part C, and
- c. 0.1% of particulates from Table 12.2-3 parts B and D.

** When hydrogen water chemistry is operating, these values are expected to increase by less than a factor of two.

CPS/USAR

TABLE 12.2-5
DESIGN-BASIS EMISSION RATE OF NOBLE GASES
 (Release Rate at Various Decay Times, $\mu\text{Ci}/\text{sec}$)

| ISOTOPE | HALF LIFE | t=0 | t=1 min | t=30 min | t=24 hr |
|---------|-----------|-----------|-----------|-----------|-----------|
| Kr-83m | 1.9 hr | 3.4 + 3 | 3.4 + 3 | 2.9 + 3 | --- |
| Kr-85m | 4.4 hr | 6.1 + 3 | 6.1 + 3 | 5.6 + 3 | 1.4 + 2 |
| Kr-85 | 10.8 yr | 10 to 20* | 10 to 20* | 10 to 20* | 10 to 20* |
| Kr-87 | 76 min | 2.0 + 4 | 1.9 + 4 | 1.5 + 4 | --- |
| Kr-88 | 2.8 hr | 2.0 + 4 | 2.0 + 4 | 1.8 + 4 | 1.1 + 2 |
| Kr-89 | 3.2 min | 1.3 + 5 | 1.0 + 5 | 1.8 + 2 | --- |
| Kr-90 | 33 sec | 2.8 + 5 | 7.7 + 4 | --- | --- |
| Kr-91 | 9.8 sec | 3.3 + 5 | 2.6 + 3 | --- | --- |
| Kr-92 | 3.0 sec | 3.3 + 5 | --- | --- | --- |
| Kr-93 | 2.0 sec | 9.3 + 4 | --- | --- | --- |
| Kr-94 | 1.4 sec | 2.3 + 4 | --- | --- | --- |
| Kr-95 | Short | 2.1 + 3 | --- | --- | --- |
| Kr-97 | 1 sec | 1.4 + 1 | --- | --- | --- |
| Xe-131m | 11.8 day | 1.5 + 1 | 1.5 + 1 | 1.5 + 1 | 1.4 + 1 |
| Xe-133m | 2.3 day | 2.9 + 2 | 2.9 + 2 | 2.8 + 2 | 2.1 + 2 |
| Xe-133 | 5.3 day | 8.2 + 3 | 8.2 + 3 | 8.2 + 3 | 7.2 + 3 |
| Xe-135m | 15.6 min | 2.6 + 4 | 2.5 + 4 | 6.9 + 3 | --- |
| Xe-135 | 9.1 hr | 2.2 + 4 | 2.2 + 4 | 2.2 + 4 | 3.6 + 3 |
| Xe-137 | 3.9 min | 1.5 + 5 | 1.3 + 5 | 6.7 + 2 | --- |
| Xe-138 | 17.5 min | 8.9 + 4 | 8.5 + 4 | 2.1 + 4 | --- |
| Xe-139 | 43 sec | 2.8 + 5 | 9.8 + 4 | --- | --- |
| Xe-140 | 16.0 sec | 3.0 + 5 | 1.6 + 4 | --- | --- |
| Xe-141 | 1.7 sec | 2.4 + 5 | --- | --- | --- |
| Xe-142 | 1.5 sec | 7.3 + 4 | --- | --- | --- |
| Xe-143 | 1 sec | 1.2 + 4 | --- | --- | --- |
| Xe-144 | ~1 sec | 5.6 + 2 | --- | --- | --- |
| | | ~2.5 + 6 | ~6.1 + 5 | ~1.0 + 5 | ~1.4 + 4 |

* Estimated from experimental observations.

CPS/USAR

TABLE 12.2-6
RADIOISOTOPE CONCENTRATIONS IN THE SPENT FUEL POOL WATER*

| ISOTOPE | CONCENTRATION $\mu\text{Ci}/\text{cm}^3$ |
|---------|---|
| Br-83 | 7.4-10** |
| Sr-89 | 7.3-5 |
| Y*-89 | 1.5-8 |
| Sr-90 | 8.5-6 |
| Sr-91 | 8.0-5 |
| Y*-91 | 5.1-5 |
| Y-91 | 1.6-5 |
| Sr-92 | 1.2-8 |
| Y-92 | 6.5-7 |
| Zr-95 | 7.0-7 |
| Nb*95 | 4.4-9 |
| Nb-95 | 4.1-8 |
| Zr-97 | 9.9-8 |
| Nb*-97 | 8.9-8 |
| Nb-97 | 1.1-7 |
| Mo-99 | 3.4-6 |
| Tc*-99 | 1.1-4 |
| Tc-99 | 1.4-11 |
| Ru-103 | 6.0-7 |
| Rh*-103 | 6.0-7 |
| Ru-106 | 2.9-7 |
| Rh-106 | 2.9-7 |
| Te*-129 | 4.2-6 |
| Te-129 | 4.2-6 |
| I-129 | 2.7-15 |
| I-131 | 2.5-4 |
| Te-132 | 2.3-3 |
| I-132 | 4.0-3 |
| I-133 | 2.5-3 |
| I-135 | 8.8-5 |

CPS/USAR

TABLE 12.2-6 (Cont'd)

| ISOTOPE | CONCENTRATION $\mu\text{Ci}/\text{cm}^3$ |
|---------|---|
| Cs-135 | 1.4-12 |
| Cs-137 | 1.2-5 |
| Ba*-137 | 1.1-5 |
| Ba-139 | 1.5-13 |
| Ba-140 | 1.4-4 |
| La-140 | 8.4-5 |
| La-141 | 6.8-8 |
| Ce-141 | 2.2-6 |
| La-142 | 2.4-14 |
| Ce-143 | 2.3-7 |
| Pr-143 | 6.0-7 |
| Ce-144 | 5.3-7 |
| Pr-144 | 5.3-7 |
| Nd-147 | 2.3-7 |
| Pm-147 | 3.4-10 |

* The activation products are not included in this list. Their concentrations are expected to be small.

** 7.4-10 should be read as 7.4×10^{-10} .

CPS/USAR

TABLE 12.2-7
N-16 INVENTORY IN EQUIPMENT CONTAINING
REACTOR WATER AND STEAM

| COMPONENT | LOCATION DRAWING | SOURCE GEOMETRY | N-16 INVENTORY, Ci |
|--------------------------------|---------------------|--------------------|-----------------------|
| RWCU regen. heat ex. | M01-1522 | Cylindrical | 29.2 |
| RWCU pump | M01-1510 | Cylindrical | 2.2 |
| Main steamlines | M01-1533 | Cylindrical | 0.12(per foot) |
| HP turbine | M01-1519 | Annular | 8.6 |
| LP turbine | M01-1519 | Annular | 8.4 |
| Intercept valve | M01-1519 | Cylindrical | 5.4 |
| Moisture separator/reheater | M01-1513 | Cylindrical | 67.6 |
| Condenser | M01-1501 | Cylindrical | 296.0 |
| Steam jet air ejector | M01-1521 | Cylindrical | 0.3 |

CPS/USAR

TABLE 12.2-8
RADIOISOTOPE INVENTORIES IN MISCELLANEOUS EQUIPMENT (Ci)* (1)

| SOURCE INVENTORY | RHR PUMP | RHR HEAT EXCHANGER | RWCU FILTER/ DEMINERALIZER | RWCU BACKWASH RECEIVING TANK | FUEL POOL FILTER/DEMIN UNIT | (2, 3) CONDENSATE FILTER | (2) CONDENSATE DEMIN. | CYCLED CONDENSATE STORAGE TANK |
|------------------|----------|--------------------|----------------------------|------------------------------|-----------------------------|--------------------------|-----------------------|--------------------------------|
| F-18 | 1.3-2 | 5.6-2 | 2.7-1 | 6.5-1 | - | - | 8.57E-01 | - |
| Na-24 | 6.7-3 | 2.8-2 | 1.1+0 | 2.6+0 | - | - | 3.20E-02 | 4.1-5 |
| P-32 | 6.7-5 | 2.8-4 | 7.2-2 | 1.7-1 | - | - | 7.32E-03 | - |
| Cr-51 | 1.7-3 | 7.0-3 | 1.9+0 | 4.6+0 | - | 2.76E-01 | - | - |
| Mn-54 | 1.3-4 | 5.6-4 | 1.7-1 | 4.1-1 | - | 3.99E-02 | - | - |
| Mn-56 | 1.7-1 | 7.0-1 | 4.7+0 | 1.1+1 | - | 1.38E-01 | - | - |
| Co-58 | 1.7-2 | 7.0-2 | 2.1+1 | 5.0+1 | - | 4.03E+00 | - | 2.4-2 |
| Co-60 | 1.7-3 | 7.0-3 | 2.1+0 | 5.0+0 | - | 5.27E-01 | - | 2.7-3 |
| Fe-59 | 2.7-4 | 1.1-3 | 3.2-1 | 7.7-1 | - | 5.54E-02 | - | 3.9-4 |
| Ni-65 | 1.0-3 | 4.2-3 | 2.8-2 | 6.7-2 | - | 8.07E-04 | - | - |
| Zn-65 | 6.7-6 | 2.8-5 | 8.4-3 | 2.0-2 | - | - | 1.19E-02 | - |
| Zn-69m | 1.0-4 | 4.2-4 | 1.5-2 | 3.6-2 | - | - | 4.41E-04 | - |
| Br-83 | 6.0-2 | 2.5-1 | 1.6+0 | 3.8+0 | 5.3-7 | - | 8.71E-01 | - |
| Br-84 | 1.2-1 | 5.2-1 | 6.9-1 | 1.7+0 | - | - | 3.96E-01 | - |
| Br-85 | 8.4-2 | 3.5-1 | 3.8-2 | 9.1-2 | - | - | 2.35E-02 | - |
| Sr-89 | 1.1-2 | 4.6-2 | 1.3+1 | 3.1+1 | 2.6+0 | - | 4.27E+00 | 1.7-2 |
| Sr-90 | 8.4-4 | 3.5-3 | 1.1+0 | 2.6+0 | 3.2-1 | - | 4.69E+00 | 1.3-3 |
| Sr-91 | 2.7-1 | 1.1+0 | 2.8+1 | 6.7+1 | 2.5-1 | - | 8.21E-01 | 8.2-5 |
| Sr-92 | 4.7-1 | 2.0+0 | 1.4+1 | 3.4+1 | 1.1-5 | - | 4.05E-01 | - |
| Zr-95 | 1.4-4 | 6.0-4 | 1.8-1 | 4.3-1 | 2.5-2 | 3.37E-02 | - | - |
| Zr-97 | 1.2-4 | 5.0-4 | 2.2-2 | 5.3-2 | 5.5-4 | 6.46E-04 | - | 1.3-6 |
| Nb-9 | 1.5-4 | 6.3-4 | 1.9-1 | 4.6-1 | 3.1-3 | 2.81E-02 | - | - |
| Mo-99 | 8.0-2 | 3.4-1 | 4.8+1 | 1.2+2 | 6.1-2 | 1.76E+00 | - | 3.6-2 |
| Tc-99m | 1.1+0 | 4.6+0 | 1.2+2 | 2.9+2 | 2.7-1 | - | 6.02E-01 | 5.1-7 |

CPS/USAR

TABLE 12.2-8
RADIOISOTOPE INVENTORIES IN MISCELLANEOUS EQUIPMENT (Continued)

| SOURCE INVENTORY | RHR PUMP | RHR HEAT EXCHANGER | RWCU FILTER/DEMINERALIZER | RWCU BACKWASH RECEIVING TANK | FUEL POOL FILTER/DEMIN UNIT | (2, 3) CONDENSATE FILTER | (2) CONDENSATE DEMIN. | CYCLED CONDENSATE STORAGE TANK |
|------------------|----------|--------------------|---------------------------|------------------------------|-----------------------------|--------------------------|-----------------------|--------------------------------|
| Tc-101 | 6.7-1 | 2.8+0 | 1.6+0 | 3.8+0 | - | - | 5.05E-02 | - |
| Ru-103 | 7.0-5 | 2.9-4 | 8.4-2 | 2.0-1 | 2.1-2 | 1.38E-02 | - | - |
| Ru-106 | 9.4-6 | 3.9-5 | 1.2-2 | 2.9-2 | 1.1-2 | 2.82E-03 | - | - |
| Ag-110m | 2.0-4 | 8.4-4 | 2.5-1 | 6.0-1 | - | 5.89E-02 | - | 3.2-4 |
| Te-129m | 1.4-4 | 3.9-4 | 1.7-1 | 4.1-1 | 1.5-1 | 2.26E-01 | - | 1.8-3 |
| Te-132 | 1.8-1 | 7.4-1 | 1.2+2 | 2.9+2 | 4.5+1 | 1.25E+00 | - | 2.9-2 |
| I-131 | 5.0-2 | 2.1-1 | 4.8+1 | 1.2+2 | 6.5+0 | - | 6.18E+01 | 5.1-2 |
| I-132 | 5.0-1 | 2.1+0 | 1.3+2 | 3.1+2 | 4.7+1 | - | 7.62E+00 | - |
| I-133 | 3.4-1 | 1.4+0 | 7.6+1 | 1.8+2 | 1.5+1 | - | 4.44E+01 | 1.0-2 |
| I-134 | 1.2+0 | 5.2+0 | 1.2+1 | 2.9+1 | - | - | 5.55E+00 | - |
| I-135 | 5.0-1 | 2.1+0 | 3.7+1 | 8.9+1 | 1.7-1 | - | 2.11E+01 | - |
| Cs-134 | 5.7-4 | 2.4-3 | 7.2-1 | 1.7+0 | - | - | 2.08E+00 | 8.9-3 |
| Cs-136 | 3.7-4 | 1.5-3 | 3.9-1 | 9.4-1 | - | - | 3.66E-02 | - |
| Cs-137 | 8.7-4 | 3.6-3 | 1.1+0 | 2.6+0 | 4.5-1 | - | 4.89E+00 | 1.3-2 |
| Cs-138 | 8.7-1 | 3.6+0 | 5.0+0 | 1.2+1 | - | - | 1.43E-01 | - |
| Ba-139 | 7.0-1 | 2.9+0 | 1.1+1 | 2.6+1 | 6.7-11 | - | 2.96E-01 | - |
| Ba-140 | 3.2-2 | 1.3-1 | 3.4+1 | 8.2+1 | 4.4+0 | - | 3.11E+00 | 3.9-2 |
| La-140 | - | - | - | - | 4.1+0 | 3.00E+00 | - | - |
| Ba-141 | 8.4-1 | 3.5+0 | 2.7+0 | 6.5+0 | - | - | 1.01E+00 | - |
| Ba-142 | 8.0-1 | 3.4+0 | 1.5+0 | 3.6+0 | - | - | 3.79E-01 | - |
| Ce-141 | 1.4-4 | 5.9-4 | 5.3-1 | 1.3+0 | 7.7-2 | 2.58E-02 | - | - |
| Ce-143 | 1.3-4 | 5.5-4 | 4.4-2 | 1.1-1 | 2.4-3 | 1.37E-03 | - | - |
| Ce-144 | 1.3-4 | 5.3-4 | 1.6-1 | 3.8-1 | 2.0-2 | 3.77E-02 | - | 2.0-4 |
| Pr-143 | 1.4-4 | 5.7-4 | 1.6-1 | 3.8-1 | 2.0-2 | 1.36E-02 | - | - |
| Nd-147 | 5.0-5 | 2.1-4 | 5.2-2 | 1.2-1 | 7.0-3 | 4.67E-03 | - | - |

CPS/USAR

TABLE 12.2-8

RADIOISOTOPE INVENTORIES IN MISCELLANEOUS EQUIPMENT (Continued)

| SOURCE INVENTORY | RHR PUMP | RHR HEAT EXCHANGER | RWCU FILTER/DEMINERALIZER | RWCU BACKWASH RECEIVING TANK | FUEL POOL FILTER/DEMIN UNIT | (2, 3) CONDENSATE FILTER | (2) CONDENSATE DEMIN. | CYCLED CONDENSATE STORAGE TANK |
|------------------|----------|--------------------|---------------------------|------------------------------|-----------------------------|--------------------------|-----------------------|--------------------------------|
| W-187 | 1.0-2 | 4.2-2 | 2.6+0 | 6.2+0 | - | 7.65E-02 | - | 4.8-4 |
| Np-239 | 9.0-1 | 3.8+0 | 4.9+2 | 1.2+3 | - | - | 1.57E+01 | 3.2-1 |

Notes

1. Source geometry and location reference for each equipment source are as follows:

| | RHR PUMP | RHR HEAT EXCHANGER | RWCU FILTER/DEMIN. | RWCU BACKWASH RECEIVING TANK | FUEL POOL FILTER/DEMIN UNIT | CONDENSATE FILTER | CONDENSATE DEMIN. | CYCLED CONDENSATE STORAGE TANK |
|--------------------|------------------|--------------------|--------------------|------------------------------|-----------------------------|-------------------|-------------------|--------------------------------|
| Source Geometry | Cylindrical | Cylindrical | Cylindrical | Cylindrical | Cylindrical | Cylindrical | Cylindrical | Cylindrical |
| Location Reference | Drawing M01-1504 | Drawing M01-1504 | Drawing M01-1522 | Drawing M01-1527 | Drawing M01-1531 | Drawing M01-1501 | Drawing M01-1501 | Drawing M01-1103 |

2. Assume 60 days hold up for filter, 3 years hold up for demineralizer.

3. This table assumes that nine filters are installed for conservatism.

CPS/USAR

TABLE 12.2-9
RADWASTE EQUIPMENT LOCATIONS
AND SOURCE GEOMETRIES FOR SHIELDING**

| TANK | LOCATION DRAWING | SOURCE GEOMETRY |
|--------------------------------------|---------------------|-----------------|
| Waste collector | M01-1502 | Cylindrical |
| Waste surge | M01-1502 | Cylindrical |
| Waste sample | M01-1514 | Cylindrical |
| Excess water | M01-1514 | Cylindrical |
| Floor drain collector | M01-1502 | Cylindrical |
| Floor drain surge | M01-1502 | Cylindrical |
| Floor drain evaporator feed | M01-1502 | Cylindrical |
| Floor drain evaporator monitor (RLR) | M01-1514 | Cylindrical |
| Chemical waste collector | M01-1502 | Cylindrical |
| Chemical waste processing | M01-1502 | Cylindrical |
| Chemical waste evaporator monitor | M01-1514 | Cylindrical |
| Phase separator | M01-1502 | Cylindrical |
| Concentrated waste | M01-1514 | Cylindrical |
| Spent resin | M01-1502 | Cylindrical |
| Fuel pool F/D sludge | M01-1502 | Cylindrical |
| Waste filter | M01-1531 | Cylindrical |
| Waste demineralizers | M01-1531 | Cylindrical |
| Chemical waste evaporator | M01-1508 | Cylindrical |
| Floor drain evaporator (RLR) | M01-1508 | Cylindrical |
| Desiccant dryer | M01-1521 | Cylindrical |
| Charcoal adsorber beds | M01-1502 | Cylindrical |

* The radioisotope inventories in radwaste handling equipment are given in Tables 12.2-10 through 12.2-12.

CPS/USAR

TABLE 12.2-10
DESIGN-BASIS INVENTORIES OF RADIOACTIVE NUCLIDES IN
MAJOR LIQUID WASTE SUBSYSTEM COMPONENTS (Ci)
WITH RESIN REGENERATION

| ISOTOPE | WASTE COLLEC. TANK | WASTE SURGE TANK | WASTE SAMPLE TANK | EXCESS WATER TANK | FLOOR DRAIN COLLEC. TANK | FLOOR DRAIN EVAP. FEED TANK | FLOOR DRAIN EVAP. MONITOR TANK | CHEM. WASTE COLLEC. TANK | CHEM. WASTE PROCESS TANK | CHEM. WASTE EVAP. MONITOR TANK | LAUNDRY DRAIN COLLEC. TANK | LAUNDRY SAMPLE TANK | WASTE FILTER | WASTE DEMINER-ALIZER | CHEM. WASTE EVAPO-RATOR | FLOOR DRAIN EVAPO-RATOR |
|---------|--------------------|------------------|-------------------|-------------------|--------------------------|-----------------------------|--------------------------------|--------------------------|--------------------------|--------------------------------|----------------------------|---------------------|--------------|----------------------|-------------------------|-------------------------|
| F-18 | 1.5-2 | 1.8-2 | 9.8-9 | 9.3-9 | 2.5-3 | 5.5-5 | 9.9-6 | 2.3-3 | 1.9-4 | 3.6-5 | 1.4-6 | 5.4-9 | 0.0 | 1.6-2 | 0.0 | 0.0 |
| Na-24 | 5.9-2 | 7.4-2 | 5.6-8 | 7.6-8 | 1.0-2 | 1.9-3 | 1.0-7 | 5.9-2 | 2.6-2 | 3.6-6 | 3.8-6 | 1.1-7 | 1.3-2 | 5.3-1 | 2.1-2 | 2.9-3 |
| P-32 | 2.2-3 | 3.4-3 | 2.5-9 | 3.6-9 | 5.2-4 | 4.7-4 | 3.1-8 | 2.3-2 | 1.6-2 | 5.2-6 | 6.0-8 | 1.3-8 | 8.7-4 | 1.5-1 | 1.7-2 | 1.4-2 |
| Cr-51 | 5.8-2 | 8.9-2 | 6.8-9 | 9.7-9 | 1.4-2 | 1.3-2 | 8.7-7 | 9.4-1 | 6.7-1 | 2.2-4 | 1.5-6 | 3.6-8 | 7.1-1 | 4.3-1 | 7.1-1 | 5.6-1 |
| Mn-54 | 4.9-3 | 7.5-3 | 5.7-10 | 8.2-10 | 1.2-3 | 1.2-3 | 7.9-8 | 1.4-1 | 9.9-2 | 3.3-5 | 1.2-7 | 3.1-9 | 6.0-2 | 4.0-2 | 1.1-1 | 7.6-2 |
| Mn-56 | 2.6-1 | 3.2-1 | 1.9-8 | 2.1-8 | 4.5-2 | 1.4-3 | 3.3-8 | 5.7-2 | 6.7-3 | 1.8-7 | 2.5-5 | 1.3-8 | 4.4-1 | 4.1-2 | 1.8-3 | 3.7-4 |
| Co-58 | 6.0-1 | 9.3-1 | 7.0-8 | 1.0-7 | 1.4-1 | 1.4-1 | 9.5-6 | 1.4+1 | 9.9+0 | 3.3-3 | 1.5-5 | 3.8-7 | 7.4+0 | 4.7+0 | 1.1+1 | 7.9+0 |
| Fe-59 | 9.5-3 | 1.5-2 | 1.1-5 | 1.6-9 | 2.3-3 | 2.2-3 | 1.5-7 | 1.9-1 | 1.4-1 | 4.5-5 | 2.4-7 | 5.9-9 | 1.2-1 | 7.3-2 | 1.5-1 | 1.1-1 |
| Co-60 | 6.1-2 | 9.5-2 | 7.2-9 | 1.0-8 | 1.5-2 | 1.5-2 | 9.9-7 | 1.8+0 | 1.3+0 | 4.4-4 | 1.5-6 | 3.9-8 | 7.6-1 | 5.0-1 | 1.4+0 | 9.9-1 |
| Ni-65 | 1.5-3 | 1.9-3 | 1.2-10 | 1.2-10 | 2.7-4 | 8.1-6 | 1.9-10 | 3.4-4 | 4.0-5 | 1.0-9 | 1.5-7 | 7.9-11 | 2.6-3 | 2.4-4 | 1.0-5 | 2.2-6 |
| Zn-65 | 2.4-4 | 3.8-4 | 2.7-10 | 3.9-10 | 5.8-5 | 5.9-5 | 3.9-9 | 6.8-3 | 4.8-3 | 1.6-6 | 6.1-9 | 1.5-9 | 9.8-5 | 1.9-2 | 5.2-3 | 3.7-3 |
| Zn-69m | 8.1-4 | 1.6-3 | 7.7-10 | 1.0-9 | 1.4-4 | 2.3-5 | 1.2-9 | 7.7-4 | 3.3-4 | 4.2-8 | 5.5-8 | 1.5-9 | 1.7-4 | 6.7-3 | 2.5-4 | 3.3-5 |
| Zn-69 | 8.1-4 | 1.0-3 | 8.0-10 | 1.1-9 | 1.4-4 | 2.5-5 | 1.3-9 | 8.2-4 | 3.5-4 | 4.5-8 | 5.3-8 | 1.6-9 | 1.8-4 | 7.2-3 | 2.7-4 | 3.6-5 |
| Br-83 | 8.6-2 | 1.1-1 | 6.2-8 | 6.5-8 | 1.5-2 | 4.3-4 | 9.8-9 | 3.6-1 | 4.0-2 | 9.6-7 | 8.4-6 | 4.1-8 | 4.5-3 | 1.2-1 | 9.8-3 | 1.1-4 |
| Br-84 | 3.9-2 | 4.9-2 | 1.2-8 | 5.2-9 | 6.8-3 | 4.3-5 | 2.3-10 | 3.6-2 | 8.7-4 | 4.7-9 | 3.8-6 | 4.1-9 | 4.5-4 | 1.2-2 | 4.8-5 | 2.4-6 |
| Br-85 | 2.5-3 | 3.1-3 | 7.5-11 | 3.3-12 | 4.3-4 | 2.6-7 | 1.3-13 | 2.1-4 | 5.0-7 | 2.5-13 | 2.4-7 | 2.5-11 | 2.7-6 | 7.5-5 | 2.6-9 | 1.3-9 |
| Sr-89 | 3.9-1 | 6.1-1 | 4.4-7 | 6.3-7 | 9.4-2 | 9.2-2 | 6.1-6 | 8.3+0 | 5.9+0 | 2.0-3 | 1.0-5 | 2.4-6 | 1.6-1 | 2.9+1 | 6.4+0 | 4.8+0 |
| Y-89m | 3.9-5 | 6.1-5 | 4.4-11 | 6.3-11 | 9.4-6 | 9.2-6 | 6.1-10 | 8.3-4 | 5.9-4 | 2.0-7 | 1.0-9 | 2.4-10 | 1.6-5 | 2.9-3 | 6.4-4 | 4.8-4 |
| Sr-90 | 3.1-2 | 4.7-2 | 3.4-8 | 5.0-8 | 7.4-3 | 7.4-3 | 5.0-7 | 9.2-1 | 6.6-1 | 2.2-4 | 7.6-7 | 1.9-7 | 1.2-2 | 2.4+0 | 7.1-1 | 5.0-1 |
| Y-90 | 1.1-2 | 2.0-2 | 1.4-8 | 2.0-8 | 3.3-3 | 5.1-3 | 3.5-7 | 8.7-1 | 6.3-1 | 2.1-4 | 8.6-8 | 1.2-7 | 5.7-3 | 1.7+0 | 6.8-1 | 4.8-1 |
| Sr-91 | 1.6+0 | 1.9+0 | 1.4-6 | 1.9-6 | 2.7-1 | 3.1-2 | 1.5-6 | 1.2+0 | 4.1-1 | 3.9-5 | 1.2-4 | 2.4-6 | 2.7-1 | 9.1+0 | 2.7-1 | 3.1-2 |
| Y-91m | 9.1-1 | 1.1+0 | 8.8-7 | 1.2-6 | 1.6-1 | 2.0-2 | 9.7-7 | 7.4-1 | 2.7-1 | 2.5-5 | 7.0-5 | 1.5-6 | 1.7-1 | 5.8+0 | 1.8-1 | 2.0-2 |
| Y-91 | 5.6-2 | 8.9-2 | 6.5-8 | 9.4-8 | 1.4-2 | 1.5-2 | 1.0-6 | 1.5+0 | 1.0+0 | 3.5-4 | 8.1-7 | 3.9-7 | 2.5-2 | 5.0+0 | 1.1+0 | 8.5-1 |

CPS/USAR

TABLE 12.2-10 (Cont'd)

| ISOTOPE | WASTE COLLEC. TANK | WASTE SURGE TANK | WASTE SAMPLE TANK | EXCESS WATER TANK | FLOOR DRAIN COLLEC. TANK | FLOOR DRAIN EVAP. FEED TANK | FLOOR DRAIN EVAP. MONITOR TANK | CHEM. WASTE COLLEC. TANK | CHEM. WASTE PROCESS TANK | CHEM. WASTE EVAP. MONITOR TANK | LAUNDRY DRAIN COLLEC. TANK | LAUNDRY SAMPLE TANK | WASTE FILTER | WASTE DEMINER-ALIZER | CHEM. WASTE EVAPO-RATOR | FLOOR DRAIN EVAPO-RATOR |
|---------|--------------------|------------------|-------------------|-------------------|--------------------------|-----------------------------|--------------------------------|--------------------------|--------------------------|--------------------------------|----------------------------|---------------------|--------------|----------------------|-------------------------|-------------------------|
| Sr-90 | 7.5-1 | 9.4-1 | 5.6-7 | 6.1-7 | 1.3-1 | 4.2-3 | 1.1-7 | 1.8-1 | 2.2-2 | 6.0-7 | 7.4-5 | 4.0-7 | 4.4-2 | 1.2+0 | 6.1-3 | 1.2-3 |
| Y-92 | 7.5-1 | 9.4-1 | 7.3-7 | 9.7-7 | 1.3-1 | 9.8-3 | 3.7-7 | 4.0-1 | 8.6-2 | 3.7-6 | 7.1-5 | 9.1-7 | 1.0-1 | 2.8+0 | 3.5-2 | 4.8-3 |
| Zr-95 | 5.1-3 | 7.9-3 | 6.0-10 | 8.6-10 | 1.2-3 | 1.2-3 | 8.1-8 | 1.2-1 | 8.3-2 | 2.8-5 | 1.3-7 | 3.2-9 | 6.4-2 | 4.1-2 | 8.9-2 | 6.7-2 |
| Nb-95m | 2.9-5 | 5.2-5 | 3.8-12 | 5.6-12 | 8.7-6 | 1.4-5 | 9.8-10 | 2.2-3 | 1.6-3 | 5.3-7 | 2.1-10 | 3.3-11 | 4.7-4 | 5.1-4 | 1.7-3 | 1.3-3 |
| Nb-95 | 5.5-3 | 8.5-3 | 6.4-10 | 9.3-10 | 1.3-3 | 1.3-3 | 8.9-8 | 1.5-1 | 1.1-1 | 3.6-5 | 1.4-7 | 3.5-9 | 6.8-2 | 4.5-2 | 1.2-1 | 8.4-2 |
| Zr-97 | 1.2-3 | 1.5-3 | 1.2-10 | 1.6-10 | 2.1-4 | 4.3-5 | 2.4-9 | 1.3-3 | 6.0-4 | 8.9-8 | 7.2-8 | 2.5-10 | 8.5-3 | 1.3-3 | 4.9-4 | 7.5-5 |
| Nb-97m | 1.2-3 | 1.5-3 | 1.2-10 | 1.6-10 | 2.1-4 | 4.2-5 | 2.4-9 | 1.3-3 | 6.0-4 | 8.9-8 | 7.2-8 | 2.5-10 | 8.4-3 | 1.3-3 | 4.9-4 | 7.5-5 |
| Nb-97 | 1.2-3 | 1.5-3 | 1.2-10 | 1.7-10 | 2.1-4 | 4.6-5 | 2.5-9 | 1.4-3 | 6.5-4 | 9.6-8 | 6.8-8 | 2.7-10 | 9.0-3 | 1.4-3 | 5.3-4 | 8.1-5 |
| Mo-99 | 1.9+0 | 2.7+0 | 2.1-7 | 3.0-7 | 4.0-1 | 2.3-1 | 1.5-5 | 5.1+0 | 3.3+0 | 8.6-4 | 6.5-5 | 7.7-7 | 2.0+1 | 7.0+0 | 3.3+0 | 1.6+0 |
| Tc-99m | 2.7+0 | 3.7+0 | 2.5-6 | 3.2-6 | 5.4-1 | 2.3-1 | 1.4-5 | 3.5+0 | 3.2+0 | 8.3-4 | 1.4-4 | 2.4-6 | 1.2+1 | 1.6+1 | 3.2+0 | 1.5+0 |
| Tc-99 | 6.6-8 | 1.1-7 | 8.0-14 | 1.2-13 | 1.9-8 | 2.6-8 | 1.8-12 | 4.2-6 | 3.0-6 | 1.0-9 | 7.8-13 | 3.4-13 | 8.6-8 | 6.4-6 | 3.2-6 | 2.3-6 |
| Tc-101 | 1.0-1 | 1.3-1 | 1.4-8 | 2.9-9 | 1.8-2 | 5.0-5 | 1.2-10 | 2.1-3 | 2.2-5 | 5.2-11 | 1.0-5 | 4.7-9 | 5.1-4 | 1.4-2 | 5.4-7 | 1.2-6 |
| Ru-103 | 2.5-3 | 3.8-3 | 2.9-10 | 4.2-10 | 5.9-4 | 5.7-4 | 3.8-8 | 4.7-2 | 3.4-2 | 1.1-5 | 6.4-8 | 1.5-9 | 3.1-2 | 1.9-2 | 3.6-2 | 2.8-2 |
| Rh-103m | 2.5-3 | 3.8-3 | 2.9-10 | 4.1-10 | 5.8-4 | 5.7-4 | 3.8-8 | 4.7-2 | 3.4-2 | 1.1-5 | 6.0-8 | 1.5-9 | 3.1-2 | 1.9-2 | 3.6-2 | 2.8-2 |
| Ru-106 | 3.4-4 | 5.3-4 | 4.0-11 | 5.8-11 | 8.2-5 | 8.2-5 | 5.5-9 | 9.7-3 | 7.0-3 | 2.3-6 | 8.5-9 | 2.2-10 | 4.2-3 | 2.8-3 | 7.5-3 | 5.4-3 |
| Rh-106 | 3.4-4 | 5.3-4 | 4.0-11 | 5.8-11 | 8.2-5 | 8.2-5 | 5.5-9 | 9.7-3 | 7.0-3 | 2.3-6 | 8.5-9 | 2.2-10 | 4.2-3 | 2.8-3 | 7.5-3 | 5.4-3 |
| Ag-110m | 7.3-3 | 1.1-2 | 8.6-10 | 1.2-9 | 1.8-3 | 1.8-3 | 1.2-7 | 2.0-1 | 1.5-1 | 4.9-5 | 1.8-7 | 4.7-9 | 9.1-2 | 5.9-2 | 1.6-1 | 1.1-1 |
| Ag-110 | 9.5-5 | 1.5-4 | 1.1-11 | 1.6-11 | 2.3-5 | 2.3-5 | 1.5-9 | 2.6-3 | 1.9-3 | 6.3-7 | 2.4-9 | 6.1-11 | 1.2-3 | 7.7-4 | 2.0-3 | 1.5-3 |
| Te-129m | 4.4-2 | 6.7-2 | 4.9-8 | 7.0-8 | 1.0-2 | 9.9-3 | 6.6-7 | 7.8-1 | 5.5-1 | 1.8-4 | 1.1-6 | 2.6-7 | 1.7-2 | 3.2+0 | 5.9-1 | 4.6-1 |
| Te-129 | 2.7-2 | 4.2-2 | 3.1-8 | 4.5-8 | 6.5-3 | 6.4-3 | 4.2-7 | 5.0-1 | 3.5-1 | 1.2-4 | 6.6-7 | 1.7-7 | 1.1-2 | 2.0+0 | 3.8-1 | 3.0-1 |
| I-129 | 8.9-12 | 1.7-11 | 1.3-17 | 2.0-17 | 2.9-12 | 5.8-12 | 3.9-15 | 3.2-9 | 2.3-9 | 7.8-12 | 5.4-17 | 1.3-16 | 5.0-12 | 2.2-9 | 2.5-9 | 1.5-9 |
| I-131 | 1.6+0 | 2.3+0 | 1.8-6 | 2.6-6 | 3.6-1 | 2.9-1 | 1.9-4 | 2.0+2 | 1.4+2 | 4.3-1 | 4.4-5 | 8.1-6 | 5.9-1 | 9.6+1 | 1.5+2 | 5.7+0 |
| Te-132 | 1.4+0 | 1.9+0 | 1.4-6 | 2.1-6 | 2.9-1 | 1.8-1 | 1.1-5 | 4.0+0 | 2.6+0 | 7.2-4 | 4.4-5 | 5.6-6 | 4.7-1 | 5.3+1 | 2.6+0 | 1.4+0 |
| I-132 | 2.0+0 | 2.8+0 | 1.9-6 | 2.6-6 | 4.0-1 | 1.9-1 | 4.8-5 | 6.8+0 | 3.0+0 | 1.4-3 | 1.1-4 | 6.0-6 | 5.1-1 | 5.5+1 | 2.8+0 | 1.5+0 |
| I-133 | 3.9-1 | 5.1-1 | 3.9-7 | 5.4-7 | 7.2-2 | 1.8-2 | 1.0-5 | 9.7+0 | 4.9+0 | 8.3-3 | 2.2-5 | 9.1-7 | 1.0-1 | 5.1+0 | 4.2+0 | 3.8-2 |
| I-134 | 5.5-1 | 6.9-1 | 2.5-7 | 1.6-7 | 9.6-2 | 9.9-4 | 8.7-8 | 8.2-1 | 3.3-2 | 2.9-6 | 5.4-5 | 9.5-8 | 1.0-2 | 2.9-1 | 3.0-3 | 8.9-5 |

CPS/USAR

TABLE 12.2-10 (Cont'd)

| ISOTOPE | WASTE COLLEC. TANK | WASTE SURGE TANK | WASTE SAMPLE TANK | EXCESS WATER TANK | FLOOR DRAIN COLLEC. TANK | FLOOR DRAIN EVAP. FEED TANK | FLOOR DRAIN EVAP. MONITOR TANK | CHEM. WASTE COLLEC. TANK | CHEM. WASTE PROCESS TANK | CHEM. WASTE EVAP. MONITOR TANK | LAUNDRY DRAIN COLLEC. TANK | LAUNDRY SAMPLE TANK | WASTE FILTER | WASTE DEMINER-ALIZER | CHEM. WASTE EVAPO-RATOR | FLOOR DRAIN EVAPO-RATOR |
|---------|--------------------|------------------|-------------------|-------------------|--------------------------|-----------------------------|--------------------------------|--------------------------|--------------------------|--------------------------------|----------------------------|---------------------|--------------|----------------------|-------------------------|-------------------------|
| Cs-134 | 2.1-2 | 3.2-2 | 2.3-6 | 3.4-6 | 5-0-3 | 5.0-3 | 3.4-7 | 6.1-1 | 4.4-1 | 1.5-4 | 5.2-7 | 1.3-7 | 8.3-3 | 1.6+0 | 4.7-1 | 3.3-1 |
| I-135 | 2.0+0 | 2.5+0 | 1.8-6 | 2.3-6 | 3.5-1 | 2.8-2 | 1.2-5 | 2.2+1 | 6.2+0 | 4.2-3 | 1.8-4 | 2.4-6 | 2.7-1 | 8.1+0 | 3.4+0 | 1.9-2 |
| Cs-135 | 3.5-9 | 5.7-9 | 8.2-13 | 1.2-12 | 9.1-10 | 1.1-9 | 4.6-12 | 2.8-6 | 2.0-6 | 1.8-8 | 3.1-14 | 2.7-14 | 1.5-9 | 7.5-7 | 2.2-6 | 7.5-8 |
| Cs-136 | 1.2-2 | 1.8-2 | 1.4-6 | 1.9-6 | 2.8-3 | 2.5-3 | 1.7-7 | 1.2-1 | 8.2-2 | 2.6-5 | 3.3-7 | 6.8-8 | 4.7-3 | 7.8-1 | 8.7-2 | 7.1-2 |
| Cs-137 | 3.2-2 | 4.9-2 | 3.6-6 | 5.1-6 | 7.6-3 | 7.7-3 | 5.2-7 | 9.6-1 | 6.9-1 | 2.3-4 | 7.9-7 | 2.0-7 | 1.3-2 | 2.5+0 | 7.4-1 | 5.2-1 |
| Ba-137m | 3.0-2 | 4.6-2 | 3.3-6 | 4.8-6 | 7.1-3 | 7.2-3 | 4.8-7 | 8.9-1 | 6.4-1 | 2.2-4 | 7.4-7 | 1.9-7 | 1.2-2 | 2.3+0 | 6.9-1 | 4.9-1 |
| Cs-138 | 2.9-1 | 3.6-1 | 8.9-6 | 3.9-6 | 5.0-2 | 3.2-4 | 1.7-9 | 1.3-2 | 3.3-4 | 1.8-9 | 2.8-5 | 3.1-8 | 3.3-3 | 9.2-2 | 1.8-5 | 1.8-5 |
| Ba-139 | 6.0-1 | 7.5-1 | 3.5-7 | 2.9-7 | 1.1-1 | 1.7-3 | 2.4-8 | 7.2-2 | 4.6-3 | 6.4-8 | 5.9-5 | 1.6-7 | 18.-2 | 5.0-1 | 6.6-4 | 2.5-4 |
| Ba-140 | 1.1+0 | 1.6+0 | 1.2-6 | 1.7-6 | 2.5-1 | 2.2-1 | 1.4-5 | 1.0+1 | 7.1+0 | 2.2-3 | 2.9-5 | 5.9-6 | 4.1-1 | 6.9+1 | 7.5+0 | 6.1+0 |
| La-140 | 5.3-1 | 9.2-1 | 6.5-7 | 9.5-7 | 1.5-1 | 1.9-1 | 1.3-5 | 1.0+1 | 7.4+0 | 2.4-3 | 4.9-6 | 4.6-6 | 2.6-1 | 6.3+1 | 7.9+0 | 6.8+0 |
| Ba-141 | 1.5-1 | 1.9-1 | 2.8-8 | 7.2-9 | 2.7-2 | 9.6-5 | 2.9-10 | 4.0-3 | 5.6-5 | 1.7-10 | 1.5-5 | 9.2-9 | 1.0-3 | 2.8-2 | 1.7-6 | 3.0-6 |
| La-141 | 1.5-1 | 1.9-1 | 1.3-7 | 1.6-7 | 2.7-2 | 1.4-3 | 4.4-8 | 5.6-2 | 9.9-3 | 3.9-7 | 1.5-5 | 1.3-7 | 1.4-2 | 3.9-1 | 3.7-3 | 5.5-4 |
| Ce-141 | 1.6-2 | 2.4-2 | 2.0-9 | 3.0-9 | 3.8-3 | 3.8-3 | 2.5-7 | 2.9-1 | 2.1-1 | 6.8-5 | 3.5-7 | 2.6-8 | 1.9-1 | 1.7-1 | 2.2-1 | 1.7-1 |
| Ba-142 | 8.7-2 | 1.1-1 | 9.7-9 | 1.5-9 | 1.5-2 | 3.3-5 | 6.2-11 | 1.4-3 | 1.2-5 | 2.2-11 | 8.6-6 | 3.2-9 | 3.5-4 | 9.6-3 | 2.2-7 | 6.3-7 |
| La-142 | 8.7-2 | 1.1-1 | 5.9-8 | 5.3-8 | 1.5-2 | 3.1-4 | 4.8-9 | 1.3-2 | 9.3-4 | 1.4-8 | 8.6-6 | 3.0-8 | 3.2-3 | 9.0-2 | 1.5-4 | 5.0-5 |
| Ce-143 | 2.2-3 | 2.9-3 | 2.2-10 | 3.2-10 | 4.1-4 | 1.5-4 | 9.1-9 | 3.5-3 | 2.0-3 | 4.2-7 | 9.5-8 | 6.3-10 | 1.9-2 | 4.4-3 | 1.9-3 | 5.1-4 |
| Pr-143 | 4.8-3 | 7.3-3 | 5.5-10 | 8.0-10 | 1.1-3 | 1.0-3 | 6.8-8 | 5.0-2 | 3.5-2 | 1.1-5 | 1.2-7 | 2.8-9 | 5.8-2 | 3.4-2 | 3.7-2 | 3.1-2 |
| Ce-144 | 4.6-3 | 7.2-3 | 5.4-10 | 7.8-10 | 1.1-3 | 1.1-3 | 7.5-8 | 1.3-1 | 9.3-2 | 3.1-5 | 1.6-7 | 3.0-9 | 5.7-2 | 3.8-2 | 1.0-1 | 7.2-2 |
| Pr-144 | 4.6-3 | 7.1-3 | 5.4-10 | 7.8-10 | 1.1-3 | 1.1-3 | 7.5-8 | 1.3-1 | 9.3-2 | 3.1-5 | 1.1-7 | 3.0-9 | 5.7-2 | 3.8-2 | 1.0-1 | 7.2-2 |
| Nd-147 | 1.6-3 | 2.5-3 | 1.9-10 | 2.7-10 | 3.8-4 | 3.3-4 | 2.2-8 | 1.4-2 | 9.7-3 | 3.0-6 | 4.4-8 | 9.2-10 | 1.9-2 | 1.1-2 | 1.0-2 | 8.3-3 |
| Pm-147 | 2.3-6 | 4.3-6 | 3.3-13 | 4.8-13 | 7.3-7 | 1.4-6 | 9.5-11 | 4.7-4 | 3.4-4 | 1.2-7 | 1.5-11 | 3.1-12 | 3.9-5 | 5.1-5 | 3.7-4 | 2.5-4 |
| W-187 | 1.3-1 | 1.7-1 | 1.3-8 | 1.9-8 | 2.4-2 | 6.7-3 | 3.9-7 | 1.7-1 | 9.2-2 | 1.7-5 | 6.7-6 | 3.3-8 | 1.1+0 | 2.0-1 | 8.0-2 | 1.7-2 |
| Np-239 | 2.0+1 | 2.8+1 | 2.1-5 | 3.0-5 | 4.1+0 | 2.1+0 | 1.4-4 | 4.7+1 | 2.9+1 | 7.4-3 | 4.2-4 | 7.3-5 | 6.6+0 | 6.3+2 | 2.9+1 | 1.3+1 |
| TOTAL | 4.2+1 | 5.7+1 | 5.8-5 | 7.1-5 | 8.4+0 | 4.1+0 | 4.5-4 | 3.6+2 | 2.3+2 | 4.6-1 | 2.0-3 | 1.2-4 | 5.4+1 | 1.4+3 | 2.4+2 | 5.6+1 |

CPS/USAR

TABLE 12.2-10A
DESIGN-BASIS INVENTORIES OF RADIOACTIVE NUCLIDES IN
MAJOR LIQUID WASTE SUBSYSTEM COMPONENTS (Ci)
WITHOUT RESIN REGENERATION (See Sec. 11.2.2.8)

| ISOTOPE | WASTE COLLEC. TANK | WASTE SURGE TANK | WASTE SAMPLE TANK | EXCESS WATER TANK | FLOOR DRAIN COLLEC. TANK | FLOOR DRAIN EVAP. FEED TANK | FLOOR DRAIN EVAP. MONITOR TANK | CHEM. WASTE COLLEC. TANK | CHEM. WASTE PROCESS TANK | CHEM. WASTE EVAP. MONITOR TANK | LAUNDRY DRAIN COLLEC. TANK | LAUNDRY SAMPLE TANK | WASTE FILTER | WASTE DEMINER-ALIZER | CHEM. WASTE EVAPO-RATOR | FLOOR DRAIN EVAPO-RATOR |
|---------|--------------------|------------------|-------------------|-------------------|--------------------------|-----------------------------|--------------------------------|--------------------------|--------------------------|--------------------------------|----------------------------|---------------------|--------------|----------------------|-------------------------|-------------------------|
| F-18 | 1.5-2 | 1.8-2 | 9.8-9 | 9.3-9 | 2.5-3 | 5.5-5 | 9.9-6 | 1.0-3 | 1.4-5 | 3.6-5 | 1.4-6 | 5.4-9 | 0.0 | 1.6-2 | 0.0 | 0.0 |
| Na-24 | 5.9-2 | 7.4-2 | 5.6-8 | 7.6-8 | 1.0-2 | 1.9-3 | 1.0-7 | 4.2-3 | 4.6-4 | 3.6-6 | 3.8-6 | 1.1-7 | 1.3-2 | 5.3-1 | 7.1-4 | 2.9-3 |
| P-32 | 2.2-3 | 3.4-3 | 2.5-9 | 3.6-9 | 5.2-4 | 4.7-4 | 3.1-8 | 5.0-4 | 3.1-4 | 5.2-6 | 6.0-8 | 1.3-8 | 8.7-4 | 3.0-1 | 9.4-3 | 1.4-2 |
| Cr-51 | 5.8-2 | 9.0-2 | 6.8-9 | 9.7-9 | 1.4-2 | 1.3-2 | 8.7-7 | 1.5-2 | 9.7-3 | 2.2-4 | 1.5-6 | 3.6-8 | 7.1-1 | 9.9-1 | 4.2-1 | 5.6-1 |
| Mn-54 | 4.9-3 | 7.5-3 | 5.7-10 | 8.2-10 | 1.2-3 | 1.2-3 | 7.9-8 | 1.4-3 | 9.8-4 | 3.3-5 | 1.2-7 | 3.1-9 | 6.0-2 | 1.0-1 | 6.3-2 | 7.6-2 |
| Mn-56 | 2.6-1 | 3.2-1 | 1.9-8 | 2.1-8 | 4.5-2 | 1.4-3 | 3.3-8 | 1.8-2 | 3.4-4 | 1.8-7 | 2.5-5 | 1.3-8 | 4.4-1 | 4.1-2 | 9.0-4 | 3.7-4 |
| Co-58 | 6.0-1 | 9.3-1 | 7.0-8 | 1.0-7 | 1.4-1 | 1.4-1 | 9.5-6 | 1.6-1 | 1.1-1 | 3.3-3 | 1.5-5 | 3.8-7 | 7.4+0 | 1.2+1 | 6.3+0 | 7.9+0 |
| Fe-59 | 9.5-3 | 1.5-2 | 1.1-5 | 1.6-9 | 2.3-3 | 2.2-3 | 1.5-7 | 2.5-3 | 1.7-3 | 4.5-5 | 2.4-7 | 5.9-9 | 1.2-1 | 1.7-1 | 8.7-2 | 1.1-1 |
| Co-60 | 6.1-2 | 9.5-2 | 7.2-9 | 1.0-8 | 1.5-2 | 1.5-2 | 9.9-7 | 1.7-2 | 1.2-2 | 4.4-4 | 1.5-6 | 3.9-8 | 7.6-1 | 1.3+0 | 8.3-1 | 9.9-1 |
| Ni-65 | 1.5-3 | 1.9-3 | 1.2-10 | 1.2-10 | 2.7-4 | 8.1-6 | 1.9-10 | 1.1-4 | 2.0-6 | 1.0-9 | 1.5-7 | 7.9-11 | 2.6-3 | 2.4-4 | 5.3-7 | 2.2-6 |
| Zn-65 | 2.4-4 | 3.8-4 | 2.7-10 | 3.9-10 | 5.8-5 | 5.9-5 | 3.9-9 | 6.8-5 | 4.9-5 | 1.6-6 | 6.1-9 | 1.5-9 | 9.8-5 | 4.9-2 | 3.1-3 | 3.7-3 |
| Zn-69m | 8.1-4 | 1.8-3 | 7.7-10 | 1.0-9 | 1.4-4 | 2.3-5 | 1.2-9 | 5.8-5 | 5.7-6 | 4.2-8 | 5.5-8 | 1.5-9 | 1.7-4 | 6.7-3 | 8.2-6 | 3.3-5 |
| Zn-69 | 8.1-4 | 1.0-3 | 8.0-10 | 1.1-9 | 1.4-4 | 2.5-5 | 1.3-9 | 5.8-5 | 6.1-4 | 4.5-8 | 5.3-8 | 1.6-9 | 1.8-4 | 7.2-3 | 8.8-6 | 3.6-5 |
| Br-83 | 8.1-2 | 1.1-1 | 6.2-8 | 6.5-8 | 1.4-2 | 4.1-4 | 9.8-9 | 5.8-3 | 1.0-4 | 9.6-7 | 8.4-6 | 4.1-8 | 4.2-3 | 1.2-1 | 2.5-5 | 1.1-4 |
| Br-84 | 3.7-2 | 4.6-2 | 1.2-8 | 5.2-9 | 6.4-3 | 4.1-5 | 2.3-10 | 2.6-3 | 1.0-5 | 4.7-9 | 3.8-6 | 4.1-9 | 4.2-4 | 1.2-2 | 5.5-7 | 2.4-6 |
| Br-85 | 2.5-3 | 2.7-3 | 7.5-11 | 3.3-12 | 3.8-4 | 2.3-7 | 1.3-13 | 1.6-4 | 5.6-8 | 2.5-13 | 2.4-7 | 2.5-11 | 2.4-6 | 6.6-5 | 2.9-10 | 1.2-9 |
| Sr-89 | 3.9-1 | 6.1-1 | 4.4-7 | 6.3-7 | 9.4-2 | 9.2-2 | 6.1-6 | 1.0-1 | 7.2-2 | 2.0-3 | 1.0-5 | 2.4-6 | 1.6-1 | 7.2+1 | 3.8+0 | 4.8+0 |
| Y-89m | 3.9-5 | 6.1-5 | 4.4-11 | 6.3-11 | 9.4-6 | 9.2-6 | 6.1-10 | 1.0-5 | 7.2-6 | 2.0-7 | 1.0-9 | 2.4-10 | 1.6-5 | 7.2-3 | 3.8-4 | 4.8-4 |
| Sr-90 | 3.1-2 | 4.7-2 | 3.4-8 | 5.0-8 | 7.4-3 | 7.4-3 | 5.0-7 | 8.7-3 | 6.3-3 | 2.2-4 | 7.6-7 | 1.9-7 | 1.2-2 | 6.3+0 | 4.2-1 | 5.0-1 |
| Y-90 | 1.1-2 | 2.0-2 | 1.4-8 | 2.0-8 | 3.3-3 | 5.1-3 | 3.5-7 | 6.5-3 | 5.5-3 | 2.1-4 | 8.6-8 | 1.2-7 | 5.7-3 | 5.5+0 | 4.2-1 | 4.8-1 |
| Sr-91 | 1.6+0 | 1.9+0 | 1.4-6 | 1.9-6 | 2.7-1 | 3.1-2 | 1.5-6 | 1.1-1 | 7.7-3 | 3.9-5 | 1.2-4 | 2.4-6 | 2.7-1 | 9.1+0 | 7.7-3 | 3.1-2 |
| Y-91m | 9.1-1 | 1.1+0 | 8.8-7 | 1.2-6 | 1.6-1 | 2.0-2 | 9.7-7 | 6.5-2 | 4.9-3 | 2.5-5 | 7.0-5 | 1.5-6 | 1.7-1 | 5.8+0 | 5.0-3 | 2.0-2 |
| Y-91 | 5.6-2 | 8.9-2 | 6.5-8 | 9.4-8 | 1.4-2 | 1.5-2 | 1.0-6 | 1.7-2 | 1.2-2 | 3.5-4 | 8.1-7 | 3.9-7 | 2.5-2 | 1.2+1 | 6.7-1 | 8.5-1 |

CPS/USAR

TABLE 12.2-10 A (Cont'd)

| ISOTOPE | WASTE COLLEC. TANK | WASTE SURGE TANK | WASTE SAMPLE TANK | EXCESS WATER TANK | FLOOR DRAIN COLLEC. TANK | FLOOR DRAIN EVAP. FEED TANK | FLOOR DRAIN EVAP. MONITOR TANK | CHEM. WASTE COLLEC. TANK | CHEM. WASTE PROCESS TANK | CHEM. WASTE EVAP. MONITOR TANK | LAUNDRY DRAIN COLLEC. TANK | LAUNDRY SAMPLE TANK | WASTE FILTER | WASTE DEMINER-ALIZER | CHEM. WASTE EVAPO-RATOR | FLOOR DRAIN EVAPO-RATOR |
|---------|--------------------|------------------|-------------------|-------------------|--------------------------|-----------------------------|--------------------------------|--------------------------|--------------------------|--------------------------------|----------------------------|---------------------|--------------|----------------------|-------------------------|-------------------------|
| Sr-90 | 7.5-1 | 9.4-1 | 5.6-7 | 6.1-7 | 1.3-1 | 4.3-3 | 1.1-7 | 5.3-2 | 1.0-3 | 6.0-7 | 7.4-5 | 4.0-7 | 4.4-2 | 1.2+0 | 2.9-4 | 1.2-3 |
| Y-92 | 7.5-1 | 9.4-1 | 7.3-7 | 9.7-7 | 1.3-1 | 9.8-3 | 3.7-7 | 5.3-2 | 2.4-3 | 3.7-6 | 7.1-5 | 9.1-7 | 1.0-1 | 2.8+0 | 1.2-3 | 4.8-3 |
| Zr-95 | 5.1-3 | 7.9-3 | 6.0-10 | 8.6-10 | 1.2-3 | 1.2-3 | 8.1-8 | 1.4-3 | 9.6-4 | 2.8-5 | 1.3-7 | 3.2-9 | 6.4-2 | 9.9-2 | 5.3-2 | 6.7-2 |
| Nb-95m | 2.9-5 | 5.2-5 | 3.8-12 | 5.6-12 | 8.8-6 | 1.4-5 | 9.8-10 | 1.9-5 | 1.6-5 | 5.3-7 | 2.1-10 | 3.3-11 | 4.7-4 | 1.6-3 | 1.1-3 | 1.3-3 |
| Nb-95 | 5.5-3 | 8.5-3 | 6.4-10 | 9.3-10 | 1.3-3 | 1.3-3 | 8.9-8 | 1.5-3 | 1.1-3 | 3.6-5 | 1.4-7 | 3.5-9 | 6.8-2 | 1.1-1 | 6.9-2 | 8.4-2 |
| Zr-97 | 1.2-3 | 1.5-3 | 1.2-10 | 1.6-10 | 2.1-4 | 4.3-5 | 2.4-9 | 8.6-5 | 1.1-5 | 8.9-8 | 7.2-8 | 2.5-10 | 8.5-3 | 1.3-3 | 1.9-5 | 7.5-5 |
| Nb-97m | 1.2-3 | 1.5-3 | 1.2-10 | 1.6-10 | 2.1-4 | 4.2-5 | 2.4-9 | 8.6-5 | 1.1-5 | 8.9-8 | 7.2-8 | 2.5-10 | 8.4-3 | 1.3-3 | 1.9-5 | 7.5-5 |
| Nb-97 | 1.2-3 | 1.5-3 | 1.2-10 | 1.7-10 | 2.1-4 | 4.6-5 | 2.5-9 | 8.6-5 | 1.1-5 | 9.6-8 | 6.8-8 | 2.7-10 | 9.0-3 | 1.4-3 | 2.0-5 | 8.1-5 |
| Mo-99 | 2.0+0 | 2.8+0 | 2.1-7 | 3.0-7 | 4.1-1 | 2.4-1 | 1.5-5 | 2.3-1 | 8.6-2 | 8.6-4 | 6.5-5 | 7.7-7 | 2.1+1 | 8.8+0 | 6.0-1 | 1.7+0 |
| Tc-99m | 2.7+0 | 3.8+0 | 2.5-6 | 3.2-6 | 5.5-1 | 2.4-1 | 1.4-5 | 2.8-1 | 8.5-2 | 8.3-4 | 1.4-4 | 2.4-6 | 1.3+1 | 1.8+1 | 5.7-1 | 1.6+0 |
| Tc-99 | 6.6-8 | 1.1-7 | 8.0-14 | 1.2-13 | 1.9-8 | 2.7-8 | 1.8-12 | 3.3-8 | 2.7-8 | 1.0-9 | 7.8-13 | 3.4-13 | 8.8-8 | 1.7-5 | 2.0-6 | 2.4-6 |
| Tc-101 | 9.3-2 | 1.2-1 | 1.4-8 | 2.9-9 | 1.6-2 | 4.5-5 | 1.2-10 | 6.6-3 | 1.1-5 | 5.2-11 | 1.0-5 | 4.7-9 | 4.7-4 | 1.3-2 | 2.7-7 | 1.1-6 |
| Ru-103 | 2.5-3 | 3.8-3 | 2.9-10 | 4.2-10 | 5.9-4 | 5.7-4 | 3.8-8 | 6.5-4 | 4.4-4 | 1.1-5 | 6.4-8 | 1.5-9 | 3.1-2 | 4.5-2 | 2.1-2 | 2.8-2 |
| Rh-103m | 2.5-3 | 3.8-3 | 2.9-10 | 4.1-10 | 5.8-4 | 5.7-4 | 3.8-8 | 6.4-4 | 4.4-4 | 1.1-5 | 6.0-8 | 1.5-9 | 3.1-2 | 4.5-2 | 2.1-2 | 2.8-2 |
| Ru-106 | 3.4-4 | 5.3-4 | 4.0-11 | 5.8-11 | 8.2-5 | 8.2-5 | 5.5-9 | 9.6-5 | 6.9-5 | 2.3-6 | 8.5-9 | 2.2-10 | 4.2-3 | 7.1-3 | 4.5-3 | 5.4-3 |
| Rh-106 | 3.4-4 | 5.3-4 | 4.0-11 | 5.8-11 | 8.2-5 | 8.2-5 | 5.5-9 | 9.6-5 | 6.9-5 | 2.3-6 | 8.5-9 | 2.2-10 | 4.2-3 | 7.1-3 | 4.5-3 | 5.4-3 |
| Ag-110m | 7.3-3 | 1.1-2 | 8.6-10 | 1.2-9 | 1.8-3 | 1.8-3 | 1.2-7 | 2.1-3 | 1.5-3 | 4.9-5 | 1.8-7 | 4.7-9 | 9.1-2 | 1.5-1 | 9.3-2 | 1.1-1 |
| Ag-110 | 9.5-5 | 1.5-4 | 1.1-11 | 1.6-11 | 2.3-5 | 2.3-5 | 1.5-9 | 2.7-5 | 1.9-5 | 6.3-7 | 2.4-9 | 6.1-11 | 1.2-3 | 2.0-3 | 1.2-3 | 1.5-3 |
| Te-129m | 4.4-2 | 6.7-2 | 4.9-8 | 7.0-8 | 1.0-2 | 9.9-3 | 6.6-7 | 1.1-2 | 7.5-3 | 1.8-4 | 1.1-6 | 2.6-7 | 1.7-2 | 7.4+0 | 3.5-1 | 4.6-1 |
| Te-129 | 2.7-2 | 4.2-2 | 3.1-8 | 4.5-8 | 6.5-3 | 6.4-3 | 4.2-7 | 7.1-3 | 4.8-3 | 1.2-4 | 6.6-7 | 1.7-7 | 1.1-2 | 4.8+0 | 2.2-1 | 3.0-1 |
| I-129 | 8.9-12 | 1.7-11 | 1.3-17 | 2.0-17 | 2.9-12 | 5.8-12 | 3.9-15 | 0 | 0 | 7.8-12 | 5.4-17 | 1.3-16 | 5.0-12 | 1.0-8 | 1.5-9 | 1.5-9 |
| I-131 | 1.6+0 | 2.3+0 | 1.8-6 | 2.6-6 | 3.6-1 | 2.9-1 | 1.9-4 | 3.0-1 | 1.7-1 | 4.3-1 | 4.4-5 | 8.1-6 | 5.9-1 | 1.6+2 | 3.2+0 | 5.7+0 |
| Te-132 | 1.4+0 | 1.9+0 | 1.4-6 | 2.1-6 | 2.7-1 | 1.7-1 | 1.1-5 | 1.6-1 | 6.4-2 | 7.2-4 | 4.4-5 | 5.6-6 | 4.4-1 | 6.3+1 | 5.2-1 | 1.3+0 |
| I-132 | 2.0+0 | 2.8+0 | 1.9-6 | 2.6-6 | 3.8-1 | 1.7-1 | 4.8-5 | 2.1-1 | 6.7-2 | 1.4-3 | 1.1-4 | 6.0-6 | 4.8-1 | 6.5+1 | 5.4-1 | 1.4+0 |
| I-133 | 3.9-1 | 5.1-1 | 3.9-7 | 5.4-7 | 7.2-2 | 1.8-2 | 1.0-5 | 3.0-2 | 4.4-3 | 8.3-3 | 2.2-5 | 9.1-7 | 1.0-1 | 5.1+0 | 9.7-5 | 3.8-2 |
| I-134 | 5.5-1 | 6.9-1 | 2.5-7 | 1.6-7 | 9.0-2 | 9.3-4 | 8.7-8 | 3.7-2 | 2.3-4 | 2.9-6 | 5.4-5 | 9.5-8 | 1.0-2 | 2.7-1 | 2.1-5 | 8.4-5 |

CPS/USAR

TABLE 12.2-10 A (Cont'd)

| ISOTOPE | WASTE COLLEC. TANK | WASTE SURGE TANK | WASTE SAMPLE TANK | EXCESS WATER TANK | FLOOR DRAIN COLLEC. TANK | FLOOR DRAIN EVAP. FEED TANK | FLOOR DRAIN EVAP. MONITOR TANK | CHEM. WASTE COLLEC. TANK | CHEM. WASTE PROCESS TANK | CHEM. WASTE EVAP. MONITOR TANK | LAUNDRY DRAIN COLLEC. TANK | LAUNDRY SAMPLE TANK | WASTE FILTER | WASTE DEMINER-ALIZER | CHEM. WASTE EVAPO-RATOR | FLOOR DRAIN EVAPO-RATOR |
|---------|--------------------|------------------|-------------------|-------------------|--------------------------|-----------------------------|--------------------------------|--------------------------|--------------------------|--------------------------------|----------------------------|---------------------|--------------|----------------------|-------------------------|-------------------------|
| Cs-134 | 2.1-2 | 3.2-2 | 2.3-6 | 3.4-6 | 5.0-3 | 5.0-3 | 3.4-7 | 5.9-3 | 4.2-3 | 1.5-4 | 5.2-7 | 1.3-7 | 8.3-3 | 4.2+0 | 2.8-1 | 3.3-1 |
| I-135 | 2.0+0 | 2.5+0 | 1.8-6 | 2.3-6 | 3.5-1 | 2.8-2 | 1.2-5 | 1.4-1 | 6.8-3 | 4.2-3 | 1.8-4 | 2.4-6 | 2.7-1 | 8.1+0 | 4.8-3 | 1.9-2 |
| Cs-135 | 3.5-9 | 5.7-9 | 8.2-13 | 1.2-12 | 9.1-10 | 1.1-9 | 4.6-12 | 1.2-9 | 1.0-9 | 1.8-8 | 3.1-14 | 2.7-14 | 1.4-9 | 8.6-7 | 6.4-8 | 7.5-8 |
| Cs-136 | 1.2-2 | 1.8-2 | 1.4-6 | 1.9-6 | 2.8-3 | 2.5-3 | 1.7-7 | 2.6-3 | 1.6-3 | 2.6-5 | 3.3-7 | 6.8-8 | 4.7-3 | 1.6+0 | 4.6-2 | 7.1-2 |
| Cs-137 | 3.2-2 | 4.9-2 | 3.6-6 | 5.1-6 | 7.7-3 | 7.7-3 | 5.2-7 | 9.1-3 | 6.5-3 | 2.3-4 | 7.9-7 | 2.0-7 | 1.3-2 | 6.5+0 | 4.4-1 | 5.2-1 |
| Ba-137m | 3.0-2 | 4.6-2 | 3.3-6 | 4.8-6 | 7.2-3 | 7.2-3 | 4.8-7 | 8.5-3 | 6.1-3 | 2.2-4 | 7.4-7 | 1.9-7 | 1.2-2 | 6.0+0 | 4.1-1 | 4.9-1 |
| Cs-138 | 2.9-1 | 3.6-1 | 8.9-6 | 3.9-6 | 4.7-2 | 3.0-4 | 1.7-9 | 1.9-2 | 7.3-5 | 1.8-9 | 2.8-5 | 3.1-8 | 3.1-3 | 8.5-2 | 4.1-6 | 1.7-5 |
| Ba-139 | 6.0-1 | 7.5-1 | 3.5-7 | 2.9-7 | 9.6-2 | 1.6-3 | 2.4-8 | 3.9-2 | 3.9-4 | 6.4-8 | 5.9-5 | 1.6-7 | 1.6-2 | 4.6-1 | 5.5-5 | 2.3-4 |
| Ba-140 | 1.1+0 | 1.6+0 | 1.2-6 | 1.7-6 | 2.4-1 | 2.2-1 | 1.4-5 | 2.3-1 | 1.4-1 | 2.2-3 | 2.9-5 | 5.9-6 | 4.1-1 | 1.4+2 | 3.9+0 | 6.0+0 |
| La-140 | 5.3-1 | 9.2-1 | 6.5-7 | 9.5-7 | 1.5-1 | 1.9-1 | 1.3-5 | 2.0-1 | 1.4-1 | 2.4-3 | 4.9-6 | 4.6-6 | 2.6-1 | 1.4+2 | 4.4+0 | 6.7+0 |
| Ba-141 | 1.5-1 | 1.9-1 | 2.8-8 | 7.2-9 | 2.5-2 | 8.9-5 | 2.9-10 | 1.0-2 | 2.2-5 | 1.7-10 | 1.5-5 | 9.2-9 | 1.0-3 | 2.6-2 | 6.8-7 | 2.8-6 |
| La-141 | 1.5-1 | 1.9-1 | 1.3-7 | 1.6-7 | 2.5-2 | 1.2-3 | 4.4-8 | 1.0-2 | 3.1-4 | 3.9-7 | 1.5-5 | 1.3-7 | 1.3-2 | 3.6-1 | 1.2-4 | 5.1-4 |
| Ce-141 | 1.6-2 | 2.4-2 | 2.0-9 | 3.0-9 | 3.6-3 | 3.6-3 | 2.5-7 | 4.0-3 | 2.7-3 | 6.8-5 | 3.5-7 | 2.6-8 | 1.9-1 | 3.8-1 | 1.2-1 | 1.7-1 |
| Ba-142 | 8.7-2 | 1.1-1 | 9.7-9 | 1.5-9 | 1.5-2 | 3.2-5 | 6.2-11 | 5.9-3 | 7.8-6 | 2.2-11 | 8.6-6 | 3.2-9 | 3.3-4 | 9.2-3 | 1.5-7 | 6.1-7 |
| La-142 | 8.7-2 | 1.1-1 | 5.9-8 | 5.3-8 | 1.5-2 | 3.0-4 | 4.8-9 | 5.9-3 | 7.3-5 | 1.4-8 | 8.6-6 | 3.0-8 | 3.1-3 | 8.7-2 | 1.2-5 | 4.8-5 |
| Ce-143 | 2.2-3 | 2.9-3 | 2.2-10 | 3.2-10 | 4.1-4 | 1.5-4 | 9.1-9 | 1.8-4 | 4.1-5 | 4.2-7 | 9.5-8 | 6.3-10 | 1.9-2 | 4.6-3 | 1.4-4 | 5.1-4 |
| Pr-143 | 4.8-3 | 7.3-3 | 5.5-10 | 8.0-10 | 1.1-3 | 1.0-3 | 6.8-8 | 1.1-3 | 6.8-4 | 1.1-5 | 1.2-7 | 2.8-9 | 5.8-2 | 6.8-2 | 2.0-2 | 3.1-2 |
| Ce-144 | 4.6-3 | 7.2-3 | 5.4-10 | 7.8-10 | 1.1-3 | 1.1-3 | 7.5-8 | 1.3-3 | 9.3-4 | 3.1-5 | 1.6-7 | 3.0-9 | 5.7-2 | 9.6-2 | 6.0-2 | 7.2-2 |
| Pr-144 | 4.6-3 | 7.1-3 | 5.4-10 | 7.8-10 | 1.1-3 | 1.1-3 | 7.5-8 | 1.3-3 | 9.3-4 | 3.1-5 | 1.1-7 | 3.0-9 | 5.7-2 | 9.6-2 | 6.0-2 | 7.2-2 |
| Nd-147 | 1.6-3 | 2.5-3 | 1.9-10 | 2.7-10 | 3.8-4 | 3.3-4 | 2.2-8 | 3.4-4 | 2.0-4 | 3.0-6 | 4.4-8 | 9.2-10 | 1.9-2 | 2.0-2 | 5.2-3 | 8.3-3 |
| Pm-147 | 2.3-6 | 4.3-6 | 3.3-13 | 4.8-13 | 7.4-7 | 1.4-6 | 9.5-11 | 2.1-6 | 2.0-6 | 1.2-7 | 1.5-11 | 3.1-12 | 3.9-5 | 2.1-4 | 2.3-4 | 2.5-4 |
| W-187 | 1.3-1 | 1.7-1 | 1.3-8 | 1.9-8 | 2.4-2 | 6.7-3 | 3.9-7 | 1.0-2 | 1.7-3 | 1.7-5 | 6.7-6 | 3.3-8 | 1.1+0 | 2.0-1 | 4.2-3 | 1.7-2 |
| Np-239 | 2.0+1 | 2.8+1 | 2.1-5 | 3.0-5 | 4.0+0 | 2.1+0 | 1.4-4 | 2.0+0 | 6.9-1 | 7.4-3 | 7.2-4 | 7.3-5 | 6.4+0 | 6.9+2 | 4.0+0 | 1.2+1 |
| TOTAL | 4.2+1 | 5.7+1 | 5.8-5 | 7.1-5 | 8.4+0 | 4.1+0 | 4.5-4 | 4.7+0 | 1.7+0 | 4.6-1 | 2.0-3 | 1.2-4 | 5.5+1 | 1.4+3 | 3.3+1 | 5.6+1 |

CPS/USAR

TABLE 12.2-11
DESIGN-BASIS INVENTORY OF RADIONUCLIDES
IN MAJOR GASEOUS WASTE SYSTEM COMPONENTS (Ci)

| DESICCANT DRYER | | | |
|-----------------|------------------|----------|-------------------|
| ISOTOPE | DESICCANT VESSEL | CHARCOAL | CHARCOAL ADSORBER |
| Br-83 | 1.89-4 | 4.10-2 | 4.53-3 |
| Kr-83m | 2.16-1 | 1.46+0 | 3.84+1 |
| Br-84 | 3.75-4 | 1.83-2 | 1.95-3 |
| Br-85 | 1.73-1 | 8.06-4 | 6.75-5 |
| Kr-85m | 3.91-1 | 2.69+0 | 1.58+2 |
| Kr-85 | 1.29-3 | 8.98-3 | 3.03+0 |
| Kr-87 | 1.26+0 | 8.46+0 | 1.53+2 |
| Kr-88 | 1.28+0 | 8.74+0 | 3.39+2 |
| Rb-88 | 1.16+0 | 8.86+0 | 3.39+2 |
| Kr-89 | 5.63+0 | 1.91+1 | --- |
| Rb-89 | 5.09+0 | 3.70+0 | --- |
| Sr-89 | 2.64+0 | 1.02-3 | --- |
| Y-89m | 9.79-4 | 2.05-3 | 1.51-3 |
| Kr-90 | 2.29+0 | 2.03+0 | 4.59-1 |
| Rb-90 | 2.10+0 | 2.21+0 | 4.59-1 |
| Sr-90 | 2.61-2 | 2.85-2 | 2.75-2 |
| Y-90 | 2.56-2 | 2.80-2 | 2.75-2 |
| Kr-91 | 4.03-2 | 1.12-2 | 1.75-3 |
| Rb-91m | 1.83-2 | 7.51-3 | 8.74-4 |
| Rb-91 | 1.88-2 | 6.94-3 | 8.74-4 |
| Sr-91 | 3.63-2 | 1.52-2 | 1.41-3 |
| Y-91m | 2.14-2 | 8.96-3 | 1.03-3 |
| Y-91 | 2.40-2 | 7.76-3 | 9.03-4 |
| I-131 | 1.59-4 | 1.80+0 | 1.99+0 |
| Xe-131m | 9.68-4 | 9.70-2 | 1.38+1 |
| I-132 | 1.58-1 | 3.28-1 | 3.61-2 |
| I-133 | 1.06-2 | 2.00+1 | 2.23+0 |
| Xe-133m | 1.74-2 | 1.73+0 | 8.35+1 |
| Xe-133 | 5.29-1 | 5.29+1 | 4.56+3 |

CPS/USAR

TABLE 12.2-11 (Cont'd)

DESICCANT DRYER

| ISOTOPE | DESICCANT VESSEL | CHARCOAL | CHARCOAL ADSORBER |
|---------|------------------|----------|-------------------|
| I-134 | 3.30-3 | 2.65-1 | 2.88-2 |
| I-135 | 1.59-3 | 9.58-1 | 1.06-2 |
| Xe-135m | 1.55+0 | 3.64+1 | 9.03+0 |
| Xe-135 | 1.43+0 | 1.35+2 | 1.22+3 |
| Cs-135 | --- | --- | 3.65-4 |
| Xe-137 | 6.96+0 | 4.49+1 | 3.18+0 |
| Cs-137 | 7.40-2 | 5.39-1 | 1.74-1 |
| Ba-137m | 6.81-2 | 4.96-1 | 1.60-1 |
| Xe-138 | 5.23+0 | 1.10+2 | 2.40+1 |
| Cs-138 | 4.71+0 | 1.11+2 | 2.40+1 |
| Xe-139 | 3.31+0 | 3.79+0 | 7.93-2 |
| Cs-139 | 3.00+0 | --- | 7.93-2 |
| Ba-139 | 2.98+0 | 4.13+0 | 7.93-2 |
| Xe-140 | 3.85-1 | 1.73-1 | 2.45-3 |
| Cs-140 | 3.60-1 | 1.98-1 | 2.45-3 |
| Ba-140 | 2.06-1 | 1.25-2 | 1.45-3 |
| La-140 | 1.88-1 | 1.14-1 | 1.31-3 |
| Total | 5.36+1 | 5.82+2 | 6.97+3 |

CPS/USAR

TABLE 12.2-12
DESIGN-BASIS INVENTORIES OF RADIOACTIVE NUCLIDES
IN MAJOR WET SOLID WASTE SUBSYSTEM COMPONENTS, IN CURIES

| ISOTOPE | PHASE SEPARATOR TANK | CONCENTRATED WASTE TANK | SPENT RESIN TANK | WASTE SLUDGE TANK | FUEL POOL F/D SLUDGE TANK |
|---------|-------------------------|----------------------------|---------------------|----------------------|------------------------------|
| H-3 | - | 5.2E-02 | 7.5E+01 | 1.5E+02 | - |
| C-14 | 7.6E+00 | 6.9E-02 | 7.0E+00 | 5.0E-01 | - |
| F-18 | 5.0E-09 | - | 2.4E-02 | - | - |
| Na-24 | 1.9E-01 | 2.6E-02 | 5.7E-01 | 9.0E-02 | - |
| P-32 | 1.8E+00 | 4.6E-02 | 1.5E-01 | 6.1E-03 | - |
| Cr-51 | 1.1E+04 | 1.8E+00 | 1.1E+03 | 5.1E+02 | - |
| Mn-54 | 1.5E+04 | 2.2E+01 | 6.1E+01 | 1.8E+02 | 2.9E+03 |
| Mn-56 | 1.3E-05 | 2.5E-03 | 1.8E-01 | 3.1E+00 | - |
| Fe-55 | 2.0E+04 | 1.0E+02 | 7.4E+01 | 2.8E+03 | 3.6E+03 |
| Co-57 | 2.9E+01 | 3.9E-02 | 1.0E-01 | 2.8E-01 | 2.3E+00 |
| Co-58 | 3.5E+03 | 2.6E+01 | 2.3E+01 | 5.2E+01 | 6.2E+02 |
| Fe-59 | 2.8E+02 | 3.7E-01 | 1.8E+01 | 1.1E+01 | 1.2E+02 |
| Co-60 | 3.0E+04 | 6.9E+01 | 1.5E+02 | 7.1E+02 | 4.8E+03 |
| Ni-63 | 3.3E+02 | 1.3E+00 | - | - | 1.1E+02 |
| Ni-65 | 6.4E-08 | 1.5E-05 | 1.1E-03 | 1.8E-02 | - |
| Zn-65 | 8.6E+02 | 6.0E-01 | 2.8E+00 | 1.2E+01 | 1.3E+02 |
| Zn-69m | 2.0E-03 | 3.2E-04 | 7.2E-03 | 1.2E-03 | - |
| Zn-69 | 2.2E-03 | 3.4E-04 | 7.6E-03 | 1.3E-03 | - |
| Br-83 | 1.7E-06 | 1.0E-02 | 1.0E+00 | 3.1E-02 | 5.3E-07 |
| Br-84 | - | 5.3E-05 | 4.3E-01 | 3.1E-03 | - |

CPS/USAR

TABLE 12.2-12 (Cont'd)

| ISOTOPE | PHASE SEPARATOR TANK | CONCENTRATED WASTE TANK | SPENT RESIN TANK | WASTE SLUDGE TANK | FUEL POOL F/D SLUDGE TANK |
|---------|----------------------|-------------------------|------------------|-------------------|---------------------------|
| Br-85 | - | 5.3E-09 | 2.6E-02 | 1.9E-05 | - |
| Sr-89 | 7.4E+02 | 1.6E+01 | 3.2E+01 | 1.1E+00 | 1.1E+01 |
| Y-89m | 1.5E-01 | 1.6E-03 | 3.2E-03 | 1.1E-04 | 1.1E-03 |
| Sr-90 | 8.9E+01 | 1.7E+00 | 2.7E+00 | 8.6E-02 | 1.6E+00 |
| Y-90 | 8.7E+01 | 1.6E+00 | 2.0E+00 | 4.0E-02 | 1.4E+00 |
| Sr-91 | 1.1E+00 | 3.4E-01 | 9.9E+00 | 1.9E+00 | 2.5E-01 |
| Y-91m | 7.3E-01 | 2.2E-01 | 6.3E+00 | 1.2E+00 | 1.6E-01 |
| Y-91 | 1.3E+02 | 2.8E+00 | 5.4E+00 | 1.7E-01 | 2.6E+00 |
| Sr-92 | 6.4E-05 | 8.5E-03 | 1.6E+00 | 3.1E-01 | 1.1E-05 |
| Y-92 | 4.3E-03 | 4.5E-02 | 3.2E+00 | 7.0E-01 | 7.6E-04 |
| Zr-95 | 1.1E+01 | 2.2E-01 | 7.4E-02 | 4.4E-01 | 1.1E-01 |
| Nb-95m | 2.1E-01 | 4.3E-03 | 1.1E-03 | 3.3E-03 | 2.0E-03 |
| Nb-95 | 1.4E+01 | 2.8E-01 | 8.7E-02 | 4.8E-01 | 3.8E-02 |
| Zr-97 | 5.6E-03 | 6.4E-04 | 1.9E-03 | 5.9E-02 | 5.5E-04 |
| Nb-97m | 5.1E-03 | 6.4E-04 | 1.9E-03 | 5.9E-02 | 5.5E-04 |
| Nb-97 | 6.1E-03 | 6.9E-04 | 2.0E-03 | 6.3E-02 | 5.9E-04 |
| Mo-99 | 1.7E+02 | 6.4E+00 | 8.7E+00 | 1.4E+02 | 7.4E-02 |
| Tc-99m | 1.7E+02 | 6.3E+00 | 1.8E+01 | 8.6E+01 | 2.8E-01 |
| Tc-99 | 3.8E-01 | 7.9E-06 | 3.5E+00 | 9.6E+00 | 2.7E-01 |
| Tc-101 | - | 2.9E-06 | 6.8E-02 | 3.6E-03 | - |
| Ru-103 | 4.2E+00 | 9.2E-02 | 3.3E-02 | 2.1E-01 | 8.5E-02 |
| Rh-103m | 4.2E+00 | 9.2E-02 | 3.3E-02 | 2.1E-01 | 8.5E-02 |

CPS/USAR

TABLE 12.2-12 (Cont'd)

| ISOTOPE | PHASE SEPARATOR TANK | CONCENTRATED WASTE TANK | SPENT RESIN TANK | WASTE SLUDGE TANK | FUEL POOL F/D SLUDGE TANK |
|---------|----------------------|-------------------------|------------------|-------------------|---------------------------|
| Ru-106 | 9.3E-01 | 1.8E-02 | 5.6E-03 | 3.0E-02 | 5.3E-02 |
| Rh-106 | 9.3E-01 | 1.8E-02 | 5.6E-03 | 3.0E-02 | 5.3E-02 |
| Ag-110m | 9.4E+01 | 3.8E-01 | 3.8E-01 | 2.2E+00 | - |
| Ag-110 | 3.9E-01 | 5.0E-03 | 1.5E-03 | 8.2E-03 | - |
| Te-129m | 7.6E+00 | 1.5E+00 | 3.4E+00 | 1.2E-01 | 5.7E-01 |
| Te-129 | 7.6E+00 | 9.7E-01 | 2.2E+00 | 7.7E-02 | 3.6E-01 |
| I-129 | - | 5.6E-09 | 3.1E-09 | 3.5E-11 | 1.7E-09 |
| I-131 | 6.5E+02 | 1.6E+02 | 1.6E+02 | 4.1E+00 | 1.4E+01 |
| Te-132 | 5.2E+02 | 5.5E+00 | 5.4E+01 | 3.3E+00 | 5.8E+01 |
| I-132 | 5.3E+02 | 5.8E+00 | 6.4E+01 | 3.6E+00 | 6.1E+01 |
| I-133 | 3.3E+01 | 4.3E+00 | 9.5E+00 | 7.0E-01 | 1.6E+01 |
| I-134 | - | 3.2E-03 | 6.1E+00 | 7.2E-02 | - |
| Cs-134 | 5.9E+01 | 1.1E+00 | 1.8E+00 | 5.8E-02 | - |
| I-135 | 2.6E-01 | 3.4E+00 | 2.9E+01 | 1.9E+00 | 1.7E-01 |
| Cs-135 | - | 2.3E-06 | 1.5E-06 | 1.0E-08 | 2.6E-07 |
| Cs-136 | 8.8E+00 | 2.3E-01 | 8.2E-01 | 3.3E-02 | - |
| Cs-137 | 9.3E+01 | 1.8E+00 | 2.8E+00 | 9.0E-02 | 2.3E+00 |
| Ba-137m | 8.5E+01 | 1.7E+00 | 2.6E+00 | 8.4E-02 | 2.1E+00 |
| Cs-138 | - | 5.4E-05 | 2.5E-01 | 2.3E-02 | - |
| Ba-139 | 8.7E-10 | 1.2E-03 | 8.2E-01 | 1.3E-01 | 6.7E-11 |
| Ba-140 | 7.2E+02 | 2.0E+01 | 7.2E+01 | 2.9E+00 | 1.2E+01 |
| La-140 | 8.4E+02 | 2.1E+01 | 6.6E+01 | 1.8E+00 | 1.3E+01 |

CPS/USAR

TABLE 12.2-12 (Cont'd)

| ISOTOPE | PHASE SEPARATOR TANK | CONCENTRATED WASTE TANK | SPENT RESIN TANK | WASTE SLUDGE TANK | FUEL POOL F/D SLUDGE TANK |
|------------|----------------------|-------------------------|------------------|-------------------|---------------------------|
| Ba-141 | - | 7.7E-06 | 1.1E-01 | 7.0E-03 | - |
| La-141 | 5.4E-04 | 4.8E-03 | 4.7E-01 | 9.7E-02 | 8.6E-05 |
| Ce-141 | 2.5E+01 | 5.7E-01 | 2.6E-01 | 1.4E+00 | 2.9E-01 |
| Ba-142 | - | 1.5E-06 | 5.6E-02 | 2.4E-03 | - |
| La-142 | 2.0E-10 | 2.5E-04 | 1.4E-01 | 2.3E-02 | 1.2E-11 |
| Ce-143 | 5.0E-02 | 2.9E-03 | 5.8E-03 | 1.4E-01 | 2.5E-03 |
| Pr-143 | 3.8E+00 | 9.8E-02 | 4.8E-02 | 4.1E-01 | 5.5E-02 |
| Ce-144 | 1.2E+01 | 2.4E-01 | 7.5E-02 | 4.0E-01 | 9.6E-02 |
| Pr-144 | 1.2E+01 | 2.4E-01 | 7.5E-02 | 4.0E-01 | 9.6E-02 |
| Nd-147 | 9.9E-01 | 2.7E-02 | 1.5E-02 | 1.4E-01 | 1.8E-02 |
| Pm-147 | 4.8E-02 | 8.7E-04 | 1.8E-04 | 2.7E-04 | 3.6E-04 |
| W-187 | 1.5E+00 | 1.1E-01 | 2.7E-01 | 7.5E+00 | - |
| Np-237 | - | - | 5.8E-01 | - | - |
| Np-239 | 1.3E+03 | 5.4E+01 | 6.5E+02 | 4.6E+01 | - |
| Pu-238 | - | 7.0E-02 | - | - | - |
| Pu-239 | - | 1.8E-04 | - | - | - |
| Pu-241 | - | 1.6E-01 | - | - | - |
| Am-241 | 6.0E-02 | - | - | - | 1.8E-02 |
| Cm-242 | 2.0E-03 | - | - | - | 9.0E-04 |
| Cm-243/244 | - | - | - | - | 3.8E-04 |
| TOTAL | 8.7E+04 | 5.4E+02 | 2.7E+03 | 4.8E+03 | 1.2E+04 |

CPS/USAR

TABLE 12.2-13
AIRBORNE RADIOACTIVITY CONCENTRATIONS ($\mu\text{Ci}/\text{cm}^3$) IN PLANT AREAS

| ISOTOPE | DRYWELL PURGE | GENERAL AREA | | RWCU F/D VALVE RM | RWCU HX A&B VALVE RM | RWCU HOLD PUMP CUB. |
|-------------------------------|------------------|--------------|--------|----------------------|-------------------------|------------------------|
| | | POWER | REFUEL | | | |
| I. PRIMARY CONTAINMENT | | | | | | |
| I-131 | 1.1-08 | 1.0-09 | 1.1-12 | 1.1-08 | 7.9-09 | 6.6-09 |
| I-133 | 7.1-08 | - | 1.1-11 | 7.6-08 | 5.3-08 | 4.4-08 |
| I-135 | 1.1-07 | - | 3.9-13 | 1.1-07 | 7.9-08 | 6.6-08 |
| Kr 85 | 4.3-10 | - | - | - | - | - |
| Kr 87 | 4.3-07 | - | - | - | - | - |
| Kr 88 | 4.3-07 | - | - | - | - | - |
| Kr 89 | 2.2-06 | - | - | - | - | - |
| Kr 90 | 1.7-06 | - | - | - | - | - |
| Xe 133 | 1.8-07 | - | - | - | - | - |
| Xe 135m | 5.3-07 | - | - | - | - | - |
| Xe 135 | 4.6-07 | - | - | - | - | - |
| Xe 137 | 2.8-06 | - | - | - | - | - |
| Xe 138 | 1.8-06 | - | - | - | - | - |
| Na 24 | 7.1-11 | - | - | 1.5-11 | 1.1-11 | 8.8-12 |
| Mn 56 | 1.8-09 | - | - | 3.8-10 | 2.6-10 | 2.2-10 |
| Co 58 | 1.8-10 | - | - | 3.8-11 | 2.6-11 | 2.2-11 |
| Co 60 | 1.8-11 | - | - | 3.8-12 | 2.6-12 | 2.2-12 |

CPS/USAR

TABLE 12.2-13 (Cont'd)

| ISOTOPE | DRYWELL PURGE | GENERAL AREA | | RWCU F/D VALVE RM | RWCU HX A&B VALVE RM | RWCU HOLD PUMP CUB. |
|---------|------------------|--------------|--------|----------------------|-------------------------|------------------------|
| | | POWER | REFUEL | | | |
| W 187 | 1.1-10 | - | - | 2.3-11 | 1.6-11 | 1.3-11 |
| Sr 89 | 1.2-10 | - | 3.2-13 | 2.5-11 | 1.7-11 | 1.5-11 |
| Sr 90 | 8.9-12 | - | 3.8-14 | 1.9-12 | 1.3-12 | 1.1-12 |
| Sr 91 | 2.9-09 | - | 3.6-13 | 6.1-10 | 4.3.10 | 3.6-10 |
| Sr 92 | 5.0-09 | - | 5.3-14 | 1.1-09 | 7.4-10 | 6.2-10 |
| Mo 99 | 8.5-10 | - | 1.5-14 | 1.8-10 | 1.3-10 | 1.1-10 |
| Tc 101 | 7.8-09 | - | - | 1.7-09 | 1.2-09 | 9.7-10 |
| Te 129M | 1.3-11 | - | 1.9-14 | 2.8-12 | 2.0-12 | 1.6-12 |
| Te 132 | 5.7-10 | - | 1.0-11 | 1.2-10 | 8.5-11 | 7.1-11 |
| Cs 134 | 6.0-12 | - | - | 1.3-12 | 9.0-13 | 7.5-13 |
| Cs 137 | 9.3-12 | - | 5.3-14 | 2.0-12 | 1.4-12 | 1.1-12 |
| CS 138 | 9.6-09 | - | - | 2.0-09 | 1.4-09 | 1.2-09 |
| Ba 139 | 7.8-09 | - | - | 1.7-09 | 1.2-09 | 9.7-10 |
| Ba 140 | 5.7-11 | - | 6.2-13 | 1.2-11 | 8.5-12 | 7.1-12 |
| Ba 141 | 9.3-09 | - | - | 2.0-09 | 1.4-09 | 1.1-09 |
| Ba 142 | 8.5-09 | - | - | 1.8-09 | 1.3-09 | 1.1-09 |
| Np 239 | 9.6-09 | - | - | 2.9-09 | 1.4-09 | 1.2-09 |

CPS/USAR

TABLE 12.2-13 (Cont'd)

| ISOTOPE | GENERAL AREAS | RHR HX CUB. A | RHR HX CUB. B | RHR PUMP CUBS. A&B | RCIC CUBICLE |
|--------------------------------------|---|------------------|--------------------|-----------------------|-----------------|
| II. <u>AUXILIARY BUILDING</u> | | | | | |
| I 131 | The general areas of the auxiliary building are fed with outside air. | 1.3-08 | Same as for RHR Hx | Same as for RHR Hx | 4.8-09 |
| I 133 | | 9.0-08 | Cubicle A | Cubicle A | 3.2-08 |
| I 135 | | 1.3-07 | | | 4.8-08 |
| Kr 85 | Airborne concentrations are negligible. | | | | 1.9-10 |
| Kr 87 | | - | | | 1.9-07 |
| Kr 88 | | - | | | 1.9-07 |
| Kr 89 | | - | | | 9.8-07 |
| Kr. 90 | | - | | | 7.5-07 |
| Xe 133 | | - | | | 8.0-08 |
| Xe 135m | | - | | | 2.4-07 |
| Xe 135 | | - | | | 2.1-07 |
| Xe 137 | | - | | | 1.3-06 |
| Xe 138 | | - | | | 8.3-07 |
| Na 24 | | 1.8-11 | | | 3.2-11 |
| Mn 56 | | 4.5-10 | | | 8.0-10 |
| Co 58 | | 4.5-11 | | | 8.0-11 |
| Co 60 | | 4.5-12 | | | 8.0-12 |
| W 187 | | 2.3-11 | | | 4.8-11 |
| Sr 89 | | 2.9-11 | | | 5.3-11 |
| Sr 90 | | 2.2-12 | | | 4.0-12 |
| Sr 91 | | 7.3-10 | | | 1.3-09 |
| Sr 92 | | 1.3-09 | | | 2.2-09 |
| Mo 99 | | 2.2-10 | | | 3.9-10 |
| Tc 101 | | 1.9-09 | | | 3.5-09 |
| Te 129m | | 3.3-12 | | | 5.9-12 |
| Te 132 | | 1.4-10 | | | 2.6-10 |
| Cs 134 | | 1.5-12 | | | 2.7-12 |
| Cs 137 | | 2.3-12 | | | 4.2-12 |
| Cs 138 | | 2.4-09 | | | 4.3-09 |
| Ba 139 | | 2.0-09 | | | 3.5-09 |
| Ba 140 | | 1.4-11 | | | 2.6-11 |
| Ba 141 | | 2.3-09 | | | 4.2-09 |
| Ba 142 | | 2.2-09 | | | 3.9-09 |
| Np 239 | | 2.4-09 | | | 4.3-09 |

CPS/USAR

TABLE 12.2-13 (Cont'd)

| ISOTOPE | GENERAL AREA | FUEL POOL COOLING PUMP ROOM | EQUIP. DRAIN PUMP ROOM | FLOOR DRAIN PUMP CUBICLE |
|----------------------------------|--|-----------------------------|--|---|
| III. <u>FUEL BUILDING</u> | | | | |
| I 131 | The general areas of the fuel building are fed by outside air. | 8.8-13 | Same airborne concentration as for Fuel Pool Cooling Pump Room | Same airborne concentration as for Fuel Pool Cooling Pump Room. |
| I 133 | | 8.8-12 | | |
| I 135 | | 3.1-13 | | |
| | Airborne concentration are negligible. | | | |
| Kr 85 | | - | | |
| KR 87 | | - | | |
| KR 88 | | - | | |
| Kr 89 | | - | | |
| Kr 90 | | - | | |
| Xe 133 | | - | | |
| Xe 135m | | - | | |
| Xe 135 | | - | | |
| XE 137 | | - | | |
| Xe 138 | | - | | |
| Na 24 | | - | | |
| Mn 56 | | - | | |
| Co 58 | | - | | |
| Co 60 | | - | | |
| W 187 | | - | | |
| Sr 89 | | 3.6-13 | | |
| Sr 90 | | 3.0-14 | | |
| Sr 91 | | 2.8-13 | | |
| Sr 92 | | 4.2-17 | | |
| Mo 99 | | 1.2-14 | | |
| Tc 101 | | - | | |
| Te 129m | | 1.5-14 | | |
| Te 132 | | 8.1-12 | Same airborne concentration as for Fuel Pool Cooling Pump Room | Same airborne concentration as for Fuel Pool Cooling Pump Room |
| Cs 134 | | - | | |
| Cs 137 | | 4.2-14 | | |
| Cs 138 | | - | | |
| Ba 139 | | 5.3-22 | | |
| Ba 140 | | 4.9-13 | | |
| Ba 141 | | - | | |
| Ba 142 | | - | | |
| Np 239 | | - | | |

CPS/USAR

TABLE 12.2-13 (Cont'd)

| ISOTOPE | GENERAL AREA | CAPPING STATION | EQUIP. DRAIN PUMP ROOM | FLOOR DRAIN PUMP ROOM |
|-------------------------------------|--|-----------------|------------------------|-----------------------|
| IV. <u>RADWASTE BUILDING</u> | | | | |
| I 131 | The general areas of Radwaste Building are fed by outside air. | 2.4-08 | 8.4-11 | 2.0-11 |
| I 133 | | 8.6-11 | 5.8-11 | 1.4-11 |
| I 135 | | 2.6-11 | 2.4-10 | 2.9-10 |
| Kr 85 | Airborne concentrations are negligible. | - | - | - |
| Kr 87 | | - | - | - |
| Kr 88 | | - | - | - |
| Kr 89 | | - | - | - |
| Kr 90 | | - | - | - |
| Xe 133 | | - | - | - |
| Xe 135m | | - | - | - |
| Xe 135 | | - | - | - |
| Xe 137 | | - | - | - |
| Xe 138 | | - | - | - |
| Na 24 | | 2.0-12 | 1.1-11 | 2.7-12 |
| Mn 56 | | 2.4-13 | 2.8-10 | 6.6-11 |
| Co 58 | | 6.6-09 | 2.8-11 | 6.6-12 |
| Co 60 | | 9.2-10 | 2.8-12 | 6.6-13 |
| W 187 | | 1.1-11 | 1.7-11 | 4.1-12 |
| Sr 89 | | 4.1-09 | 1.8-11 | 4.4-12 |
| Sr 90 | | 4.6-10 | 1.4-12 | 4.8-13 |
| Sr 91 | | 2.1-11 | 4.6-10 | 1.1-10 |
| Sr 92 | | 7.9-13 | 7.9-10 | 1.9-10 |
| Mo 99 | | 1.2-09 | 1.4-10 | 3.3-11 |
| Tc 101 | | 7.3-16 | 1.2-09 | 3.0-10 |
| Te 129m | | 4.1-10 | 2.1-12 | 4.8-13 |
| Te 132 | | 1.0-09 | 9.0-11 | 2.2-11 |
| Cs 134 | | 3.2-10 | 9.5-13 | 2.3-13 |
| Cs 137 | | 4.6-10 | 1.5-12 | 3.5-13 |
| Cs 138 | | 2.0-14 | - | - |
| Ba 139 | | 1.6-13 | 1.2-09 | 3.0-10 |
| Ba 140 | | 5.0-09 | 5.3-11 | 3.5-11 |
| Ba 141 | | 1.9-15 | 1.5-09 | 3.5-10 |
| Ba 142 | | 4.1-16 | 1.4-09 | 3.3-10 |
| Np 239 | | 9.2-09 | 1.5-09 | 3.7-10 |

CPS/USAR

TABLE 12.2-13 (Cont'd)

| ISOTOPE | CHEM WASTE SYSTEM | EQUIP. DRAIN SYSTEM | DEMINERALIZER |
|---|----------------------|------------------------|---------------|
| V. <u>RADWASTE BUILDING VALVE AISLES</u> | | | |
| I 131 | 8.0-09 | 8.4-11 | 2.6-09 |
| I 133 | 6.4-10 | 5.8-11 | 2.6-10 |
| I 135 | 8.5-10 | 2.4-10 | 2.6-10 |
| Kr 85 | - | | |
| Kr 87 | - | - | - |
| Kr 88 | - | - | - |
| Kr 89 | - | - | - |
| Kr 90 | - | - | - |
| Xe 133 | - | - | - |
| Xe 135m | - | - | - |
| Xe 135 | - | - | - |
| Xe 137 | - | - | - |
| Xe 138 | - | - | - |
| Na 24 | 4.4-12 | 1.1-11 | 1.7-11 |
| Mn 56 | 1.9-11 | 2.8-10 | 1.2-12 |
| Co 58 | 5.8-10 | 2.8-11 | 1.3-10 |
| Co 60 | 7.4-11 | 2.8-12 | 1.4-11 |
| W 187 | 1.0-11 | 1.7-11 | 5.8-12 |
| Sr 89 | 3.3-10 | 1.8-11 | 8.2-10 |
| Sr 90 | 3.6-11 | 1.4-12 | 6.6-11 |
| Sr 91 | 1.2-10 | 4.6-10 | 2.9-10 |
| Sr 92 | 5.8-11 | 7.9-10 | 3.7-11 |
| Mo 99 | 2.4-10 | 1.4-10 | 1.9-10 |
| Tc 101 | 7.4-12 | 1.2-09 | 4.2-13 |
| Te 129m | 3.1-11 | 2.1-12 | 8.7-11 |
| Te 132 | 1.8-10 | 9.0-11 | 1.5-09 |
| Cs 134 | 2.4-11 | 9.5-13 | 4.2-11 |
| Cs 137 | 3.8-11 | 1.5-12 | 6.6-11 |
| Cs 138 | - | - | 2.9-12 |
| Ba 139 | 4.4-11 | 1.2-09 | 1.5-11 |
| Ba 140 | 4.2-10 | 5.3-11 | 2.0-09 |
| Ba 141 | 1.2-11 | 1.5-09 | 8.5-13 |
| Ba 142 | 6.4-12 | 1.4-09 | 2.9-13 |
| Np 239 | 2.2-09 | 1.5-09 | 1.8-08 |

CPS/USAR

TABLE 12.2-13 (Cont'd)

| ISOTOPE | GENERAL AREAS* | CONDENSER CAVITY | CONDENSATE POL. SUMP RM. | EQUIP. DRAIN PUMP ROOM** |
|------------------------------------|---|---------------------|-----------------------------|-----------------------------|
| VI. <u>TURBINE BUILDING</u> | | | | |
| I 131 | The general areas of the turbine building are fed by outside air. | 7.7-11 | 3.9-09 | 4.2-11 |
| I 133 | | 5.1-10 | 2.9-10 | 2.9-11 |
| I 135 | | 7.7-10 | 1.4-09 | 4.2-10 |
| | Airborne concentrations are negligible. | | | |
| Kr 85 | | 3.8-12 | 4.2-12 | - |
| Kr 87 | | 3.8-09 | - | - |
| Kr 88 | | 3.8-09 | - | - |
| Kr 89 | | 1.6-08 | - | - |
| Kr 90 | | 1.2-08 | - | - |
| Xe 133 | | 1.3-09 | 2.9-07 | - |
| Xe 135m | | 3.9-09 | 4.2-07 | - |
| Xe 135 | | 3.3-09 | 1.4-06 | - |
| Xe 137 | | 2.0-08 | - | - |
| Xe 138 | | 1.3-08 | - | - |
| Na 24 | | 5.1-13 | 2.1-12 | 5.6-12 |
| Mn 56 | | 1.3-11 | 9.0-12 | 1.4-10 |
| Co 58 | | 1.3-12 | 2.6-10 | 1.4-11 |
| Co 60 | | 1.3-13 | 3.4-11 | 1.4-12 |
| W 187 | | 7.7-13 | 5.0-12 | 8.5-12 |
| Sr 89 | | 8.5-13 | 1.6-10 | 9.2-13 |
| Sr 90 | | 6.4-14 | 1.7-11 | 7.2-13 |
| Sr 91 | | 2.1-11 | 5.6-11 | 2.3-10 |
| Sr 92 | | 3.6-11 | 5.3-12 | 4.0-10 |
| Mo 99 | | 6.2-12 | 1.1-10 | 6.9-11 |
| Tc 101 | | 5.6-11 | 3.7-12 | 6.1-10 |
| Te 129m | | 9.5-14 | 1.5-11 | 1.0-12 |
| Te 132 | | 4.1-12 | 8.7-11 | 4.5-11 |
| Cs 134 | | 4.3-14 | 1.1-11 | 4.8-13 |
| Cs 137 | | 6.7-14 | 1.8-11 | 7.4-13 |
| Cs 138 | | 6.9-11 | 1.0-11 | - |
| Ba 139 | | 5.7-11 | 2.1-11 | 6.1-10 |
| Ba 140 | | 4.1-13 | 2.0-10 | 2.6-11 |
| Ba 141 | | 6.7-11 | 5.6-12 | 7.4-10 |
| Ba 142 | | 6.1-11 | 3.2-12 | 6.9-10 |
| Np 239 | | 6.9-11 | 1.1-09 | 7.7-10 |

* Includes turbine-driven feed pump room

** Same concentrations in floor drain pump room

CPS/USAR

TABLE 12.2-13 (Cont'd)

| ISOTOPE | GENERAL AREAS* | CONDENSER CAVITY | CONDENSATE POL. SUMP RM. | EQUIP. DRAIN PUMP ROOM** |
|------------------------------|--|---|-----------------------------|-----------------------------|
| VII. CONTROL BUILDING | | | | |
| I 131 | The general areas of the control building are fed with outside air. | 4.6-12 | 4.0-13 | 1.4-12 |
| I 133 | | 3.0-11 | 2.6.12 | 1.4-11 |
| I 135 | | Airborne concentrations are negligible. | 4.6-11 | 4.0-12 |
| Kr 85 | | - | - | - |
| Kr 87 | | - | - | - |
| Kr 88 | | - | - | - |
| Kr 89 | | - | - | - |
| Kr 90 | | - | - | - |
| Xe 133 | | - | - | - |
| Xe 135m | | - | - | - |
| Xe 135 | | - | - | - |
| Xe 137 | | - | - | - |
| Xe 138 | | - | - | - |
| Na 24 | | 6.1-13 | 5.3-14 | 1.9-13 |
| Mn 56 | | 1.5-11 | 1.3-12 | 4.8-12 |
| Co 58 | | 1.5-12 | 1.3-13 | 4.8-13 |
| Co 60 | | 1.5-13 | 1.3-14 | 4.8-14 |
| W 187 | | 9.2-13 | 8.0-14 | 2.8-13 |
| Sr 89 | | 1.0-12 | 8.7-14 | 3.2-13 |
| Sr 90 | | 7.6-14 | 6.6-15 | 2.4-14 |
| Sr 91 | | 2.5-11 | 2.1-12 | 7.8-12 |
| Sr 92 | | 4.3-11 | 3.7-12 | 1.3-11 |
| Mo 99 | | 7.3-12 | 6.4-13 | 2.3-12 |
| Tc 101 | | 6.7-11 | 5.8-12 | 2.1-11 |
| Te 129m | | 1.1-13 | 9.8-15 | 3.5-14 |
| Te 132 | | 4.9-12 | 4.2-13 | 1.5-12 |
| Cs 134 | | 5.2-14 | 4.5-15 | 1.6-14 |
| Cs 137 | | 7.9-14 | 6.9-15 | 2.5-14 |
| Cs 138 | | 8.2-11 | 7.2-12 | 2.6-11 |
| Ba 139 | | 6.7-11 | 5.8-12 | 2.1-11 |
| Ba 140 | | 4.9-13 | 4.2-14 | 1.5-13 |
| Ba 141 | | 7.9-11 | 6.9-12 | 2.5-11 |
| Ba 142 | | 7.3-11 | 6.4-12 | 2.3-11 |
| Np 239 | | 8.2-11 | 7.2-12 | 2.6-11 |

CPS/USAR

TABLE 12.2-14
ACTIVITY INVENTORIES RELEASED TO THE SUPPRESSION POOL
FROM RELIEF VALVES AFTER SCRAM

| TIME (hrs) | CUMULATIVE ACTIVITY INVENTORIES (curies) | |
|---------------|---|----------|
| | Xe 133 | I 131 |
| 0.00102 | 1.03E-03 | 1.26E-03 |
| 0.00383 | 1.83E-01 | 2.24E-01 |
| 0.1 | 4.11E-01 | 5.03E-01 |
| 0.2 | 6.47E-01 | 7.93E-01 |
| 0.3 | 8.84E-01 | 1.08E+00 |
| 0.4 | 1.12E+00 | 1.37E+00 |
| 0.5 | 1.36E+00 | 1.66E+00 |
| 0.75 | 1.88E+00 | 2.30E+00 |
| 1 | 2.40E+00 | 2.93E+00 |
| 1.5055 | 3.45E+00 | 4.22E+00 |
| 2 | 4.01E+00 | 4.91E+00 |
| 2.7277 | 4.84E+00 | 5.94E+00 |
| 3.0055 | 5.20E+00 | 6.37E+00 |
| 3.5 | 5.82E+00 | 7.14E+00 |
| 3.6277 | 5.99E+00 | 7.33E+00 |

Notes: The above activities are based on plant operation at Technical Specification concentrations.

The release is not corrected for radioactive decay, nor is it corrected for evolution to the containment air.

These are not "equivalent" activities.

Reference: IP Calculation M/NSED IP-M-0313

These values are based on the SRV Mass Blowdown rate at 2894 MWt per USAR Table 15.2.4-2.

CPS/USAR

TABLE 12.2-15
TRAVERSING INCORE PROBE (TIP) SYSTEM RADIATION LEVELS

A. Material Compositions

1. Detector Region

| | |
|----------------------------|------------|
| AISI 304 Stainless Steel | 3.27 gm |
| Commercially Pure Titanium | 1.73 gm |
| Forsterite Ceramic | 0.181 gm |
| Nichrome | 0.048 gm |
| Uranium 235 | 0.00075 gm |
| Nickel | 0.026 gm |
| Alumina | 0.348 gm. |

2. Cable Region

| | |
|---------------------------|--------------------|
| AISI 304L Stainless Steel | 0.254 gm per inch |
| AISI C1070 Carbon Steel | 2.16 gm per inch |
| Magnesium Oxide | 0.0495 gm per inch |

B. Radiation Levels

| Decay Time, Days | Exposure Rate, Rem/hr | | |
|---------------------|-----------------------|--------------------|-------|
| | Detector ¹ | Cable ² | Total |
| 0.01 | 2.32 | 81.5 | 84.1 |
| 0.1 | 1.2 | 44.5 | 45.7 |
| 0.25 | 0.5 | 17.2 | 17.7 |
| 0.5 | 0.12 | 3.77 | 3.9 |
| 1.0 | 0.04 | 0.57 | 0.62 |
| 1.5 | 0.04 | 0.45 | 0.49 |
| 2.0 | 0.04 | 0.44 | 0.48 |

1 At one meter from a TIP detector.

2 At six feet down the cable from a twelve foot portion of the activated cable.

CPS/USAR

12.3 RADIATION PROTECTION DESIGN FEATURES

This section enumerates specific features provided in the CPS design for the purpose of maintaining personnel radiation exposures as low as reasonably achievable (ALARA) in accordance with the guidance provided in Regulatory Guide 8.8. The general considerations, design objectives and criteria are given in Subsection 12.1.2.

12.3.1 Facility Design Features

The radiation level experience gained from operating plants and an analysis of the personnel exposure records, in addition to the calculation of radiation source values, have formed the basis for design of various radiation protection features at CPS. Specific design features are described below under different categories.

12.3.1.1 Radiation Zones

From the plant design considerations, five radiation zones are defined. The dose rate criterion used for general access areas, such as hallways and corridors, is 0.5 mrem/hr or less, in keeping with the ALARA design philosophy. Dose rates and access control criteria for all the zones are given below.

| Zone Designation | Maximum Dose Rate (mrem/hr) | Access Control |
|------------------|--------------------------------|--|
| A | 0.5 | Controlled, unlimited access |
| B | 2.5 | Controlled, limited access |
| C | 20 | Controlled, limited access |
| D | 100 | Controlled, limited access |
| E | Over 100 | Areas locked when over 1000 mrem/hr, Authorization Required for Access (see Subsection 12.5.2) |

- a. Zone A designates regions such as office areas, operating areas, and passageways designed to a peak dose rate of 0.5 mrem/hr, a condition permitting continuous occupancy on a 40-hour-per-week, 50-week per-year basis such that access to these areas is not limited from a radiation exposure standpoint.
- b. Zone B designates regions designed to a peak dose rate of 2.5 mrem/hr requiring personnel access where operations are of a transient nature.
- c. Zone C is used to indicate areas within the station which are "radiation areas," as defined in Section 20.1003 of 10 CFR 20, but with peak dose rates less than 20 mrem/hr. Frequent access or extended occupancy is not expected in such areas. Certain administrative controls are necessary for entry. Whenever

CPS/USAR

possible, based on design and construction considerations, auxiliary equipment requiring manual operation, inspection or maintenance during unit operation is not located in Zone C areas.

- d. Zone D is used to indicate areas within the station which are "radiation areas" having peak dose rates less than 100 mrem/hr. All the restrictions described above for Zone C areas apply equally to Zone D areas except that permitted occupancy times are less for Zone D than for Zone C.
- e. Areas designated as Zone E are "high radiation areas," as defined in Section 20.1003 of 10 CFR 20. The design dose rate in Zone E areas may exceed 100 mrem/hr. Access to each Zone E area is controlled by suitable means (see Subsection 12.5.2). Occupancy of such areas is limited as to both frequency and duration and is controlled by a Radiation Work Permit.

The actual zones are to be determined by periodic measurements. The actual access control and posting is to be done based upon the operating radiation zones.

12.3.1.2 Mechanical System Design Features

Redundant equipment, isolation valves to avoid dead legs, and the use of filter/demineralizers to remove radioactive material have been employed in the CPS design. Drawing M05-1076 shows the use of redundant RWCU heat exchangers, for example, and Drawing M05-1037 shows the use of liquid filter/demineralizers.

12.3.1.3 Equipment Layout Features

Figures 12.3-30 through 12.3-35 give illustrations of equipment layout features for various pieces of equipment and subsystems at CPS. The features employed are described briefly in Subsection 12.1.2 and are illustrated here.

12.3.1.3.1 Shielding

Shielding is provided for all equipment and pipes such that the radiation zone criteria of Subsection 12.3.1.1 are met. Details of shielding design are given in Subsection 12.3.2.

12.3.1.3.2 Separation

To the extent practical, each piece of equipment is separated from the other with shield walls and slabs, with particular emphasis given to separating the high-maintenance items such as valves and pumps from the low-maintenance items such as tanks. This feature is illustrated in Figures 12.3-30 through 12.3-32. For two pieces of equipment located in the same room, a permanent shadow shield is provided where practical, or sufficient space is provided for temporary shielding and maintenance operations. Valves are located in separate valve aisles as in Figure 12.3-30, or otherwise in the pump cubicles, but not in tank cubicles to the extent practicable.

12.3.1.3.3 Sampling and Instrument Locations

Sample panels are provided at various places in the plant for taking grab samples. The criteria used in locating the sample panels are that they should be in a close proximity to the high-level radioactive sample origins, and should allow grouping of several sample taps to facilitate proper ventilation. Figure 12.3-31 illustrates the location of the sample panel for the spent resin tank. Flushing connections are provided for all high-level sample lines. Tanks designed to receive lead shot as radiation shielding have been built into process sample panels expected to have high radiation levels during use. The use of additional shielding in these panels aids in keeping personnel exposures ALARA.

Local instrument panels are located outside the high radiation areas; specific examples are illustrated on Figures 12.3-31, 12.3-32, and 12.3-33. Provisions are made, where practical, to remotely monitor the liquid flows and resin levels.

12.3.1.3.4 Skyshine

Most steam cycle equipment subject to N-16 radiation which contribute to skyshine (i.e., feedwater heaters, moisture separator/reheaters, etc.) are shielded on all sides as necessary except the low-pressure and high-pressure turbines and the turbine driven reactor feed pumps (which have no shielding in the overhead). Hence the question of skyshine dose arises only for the latter pieces of equipment. In order to limit the onsite and offsite doses from skyshine to acceptable levels, the solid angle of skyshine radiation from the turbines is controlled by providing 15-foot-high concrete walls around them.

12.3.1.3.5 Steam Separator and Dryer Transfer

The transfer of steam separators and dryers from the vessel to their temporary locations during refueling can give rise to airborne radioactivity on the refueling floor. At CPS, this possibility is minimized by reducing the amount of time these components are not covered with water. Both storage pools are kept full of water before, during, and after the transfer sequence so that the dryer and separator are shielded by water and surfaces do not dry out. In addition, provisions are in place to ensure these components will be kept moist if there is a delay in the transfer sequence, and thus also minimize the potential for airborne radioactivity.

12.3.1.4 Personnel Access

Personnel access control design considerations are discussed in Subsection 12.1.2. The following provisions are made for personnel access in the design.

12.3.1.4.1 Labyrinths

Entrance to cubicles containing radiation is primarily through doors for ease of access. Labyrinths are provided at cubicle entrances to shield station personnel from direct radiation should the radiation levels inside the cubicle warrant such controls. The following features have been provided at CPS:

- a. To the extent practical, entrance to a cubicle is provided in the area with potentially lowest radiation level in the cubicle. Figure 12.3-35 illustrates this

CPS/USAR

principle and the desirable access locations for a tank and related pump cubicles. Figure 12.3-31 illustrates one of the places at CPS where this principle has been used.

- b. Labyrinths are provided with sufficient overlapping walls (overlap is 1-1/2 times the door width in most cases) and ceilings to shield against scattered radiation.
- c. Double labyrinths are used when single labyrinths may not provide sufficient protection against scattered radiation. Such is the case for strong sources of gamma rays of low energies (Reference 1) as found in the radwaste building. Figure 12.3-31 provides an illustration of this feature.

12.3.1.4.2 Shield Plugs

Concrete shield plugs are provided for access in cases where frequent access is neither required nor desired. Access to all the liquid filter/demineralizer cubicles has been provided through shield plugs in the ceiling, as illustrated in Figure 12.3-30. In the case of the Condensate Polishers with the Condensate Filters installed an additional access has been provided via a door.

12.3.1.4.3 Ladders and Galleries

Permanent access ladders and galleries are provided in most radiation areas where occasional access is required for maintenance and inspection. This helps to reduce the time spent in radiation areas and hence reduce personnel radiation exposure.

12.3.1.5 Equipment Removal

Equipment removal features which are important from radiological protection considerations are described below.

12.3.1.5.1 Hatches/Shield Plugs

Where periodic equipment or filter removal is involved, hatches or shield plugs are employed for the purpose of saving time and minimizing exposure. The Drywell and Containment buildings are equipped with equipment removal hatches and liquid filter/demineralizer cubicles and the desiccant dryer cubicle (Figure 12.3-34) are equipped with shield plugs. Removable steel shields are provided for turbine removal.

12.3.1.5.2 Removable Block Walls

When equipment removal is not periodic but can be expected occasionally for maintenance purposes, removable block wall sections are employed as illustrated in Figure 12.3-32 for the radwaste evaporator. For easy and quick removal, the block wall sections are constructed of unmortared concrete blocks stacked together and supported by a steel frame.

12.3.1.5.3 Cranes and Pull Spaces

Where movement of heavy components is involved, cranes and trolley beams are provided. Clear pull spaces are also provided for the removal of heat exchanger and condenser tubes.

12.3.1.6 Remote Operation

Radwaste solidification (i.e., processing and monitoring) is performed remotely to the extent practical. Fuel inspection and handling and inservice inspection of the reactor vessel and associated piping are also performed remotely with special tools.

12.3.1.7 Radioactive Crud Control

Deposition of radioactive corrosion and activation products, commonly referred to as crud, on internal surfaces of equipment is recognized as a major source of radiation exposure, particularly during maintenance operations. Efforts have been made to minimize the crud problem in the station through the selection of materials with minimum possible amounts of nickel and cobalt, design of equipment and systems that minimize crud traps, use of packaging and handling practices that minimize the introduction of foreign materials, and provision of cleanup and decontamination facilities for crud removal.

Dissolved oxygen (DO) is monitored during most modes of unit operation. Continuous DO monitoring capability is provided for: reactor water, control rod drive water, condensate pump discharge header, condensate polisher outlet header, and reactor feedwater. DO control during operation is provided by steam jet air ejectors on the condenser and the feedwater oxygen injection skid, Ref. Drawing M05-1005 Sht 3.

To minimize radiation dose rates, a passive GE zinc injection passivation (GEZIP) system injects small amounts of depleted zinc oxide (DZO) into the feedwater during normal operation. Depleted zinc oxide injection will reduce shutdown dose rates in the drywell because the zinc forms a thin protective oxide layer on the primary system piping and reduces Co-60 buildup. Co-60 buildup is the major source of shutdown radiation fields and occupational radiation exposure

During start up evolutions, the Auxiliary Steam (AS) System supplies steam for main condenser and condensate deaeration. Feedwater DO is further controlled by circulating the feedwater back to the condenser hotwell prior to injection into the reactor vessel.

When practicable during shutdown periods, a continuous flow of high purity water will be maintained through the feedwater systems. By maintaining a continuous closed loop recirculation through the condensate polishers, oxygen corrosion cells on metal surfaces are minimized from forming and corrosion rates are significantly reduced. This practice will also minimize startup concentrations of corrosion products following shutdown periods.

As a BWR, CPS will not be using chemical additions to the reactor coolant to adjust pH. Chemistry control is effected by maintenance of water quality in accordance with the plant Technical Specifications, Regulatory Guide 1.56, Operational Requirements Manual (ORM), Fuel Warranty, and selected BWR Water Chemistry Guidelines. (Q&R 471.09).

Further reduction of crud buildup is accomplished by design features as described in the CPS response to Grand Gulf Question 331.15, which was incorporated into revised Subsection 12.3.1.7.

CPS/USAR

12.3.1.7.1 Material Selection

- a. The majority of materials for the piping and fittings in contact with the reactor coolant are carbon steel SA-106 (Grade B or C) and SA-105, respectively. These materials contain only trace amounts of nickel and cobalt.
- b. Stainless steel is used in instrument piping, to minimize corrosion products from piping that may enter that instrument, and in feedwater heaters and other heat exchanger tubes to minimize corrosion products. Stainless steel contains 10 to 15.0 percent nickel.

Reactor recirculation system and most of the vessel internal components are made of stainless steel. A small amount of nickel base material (Inconel 600) is employed in the reactor vessel internal components. Inconel 600 is required where components are attached to the reactor vessel shell, and the coefficient of expansion must match the thermal expansion characteristics of the low alloy vessel steel. Inconel 600 was selected because it provides the proper thermal expansion characteristics, adequate corrosion resistance, and can be readily fabricated and welded. Alternate low nickel materials which meet the above requirements and are suitable for long-term reactor service are not available.

- c. The plant was constructed with Stellite as the preferred valve hard facing material due to its superior wear resistance property. However, operational experience has shown that about ninety percent of radiation exposure is caused by activated cobalt. Much of this is thought to come from corrosion and the small amount of wear of Stellite (approximately 55% cobalt) hard facing on valves. To reduce this source of activated corrosion products, Stellite hard facing may be replaced with no hard facing or with suitable low or no cobalt hard facing as appropriate by engineering evaluation. The engineering evaluation among other things will ensure the material is compatible with the reactor coolant and the needs of the Generic Letter 89-10 program are met if 89-10 valves are affected. Materials for all safety-related valves conform to the requirements of Section III of the ASME Boiler and Pressure Vessel Code.
- d. Valve packing selected is the braided packing without any loose filler material. Where possible, packing material selected is John Crane 187, Grafoil or Chesterton Graphite acceptable for nuclear service. The packing is chloride free with minimal halogens to prevent stem pitting. In other cases, the valve packing will be at the recommendation of the manufacturer.

12.3.1.7.2 Equipment and System Design

To the extent practical, equipment and system design minimizes crud pockets.

- a. Welded joints are made without backing rings. Flange connections are avoided as much as practicable.
- b. Drains and other piping are routed with sufficient slopes, where necessary, to minimize plateout on internal surfaces.

CPS/USAR

- c. Valves with minimal amounts of internal crevices are used. Practically all valves in the radwaste systems are plug type valves. Also, full ported valves are used extensively.
- d. Radioactive tanks designed to contain liquids and/or sludges with higher activity levels are designed to be vertical with conical bottoms, as illustrated in Fig. 12.3-36. In the exceptional case of the backwash receiving tank of the reactor water cleanup system (Fig. 12.3-30), the tank is horizontal but has a sloped bottom. A 1/2-inch inside radius is provided on all inner corners of tanks. Holding tanks designed for lower activity liquids (such as the waste sample and excess water tanks) are horizontal.

12.3.1.7.3 Packaging and Handling Practices

- a. Guidance provided in ANSI standard N45.2.2-1972 was followed. Materials used for cleaning were chosen so as to limit films and contamination that could become radioactive. Stainless steel components were handled using non-ferrous strings and ropes to prevent ferrous contamination.
- b. For any pipe or valve surface that came in contact with reactor water, chrome plating and treatment with halogens and nitrides were prohibited.

12.3.1.7.4 Cleanup Features

- a. Reactor water cleanup system is provided to filter and demineralize reactor coolant continuously and thus reduce the contaminants in the water.
- b. A full flow condensate polisher system is provided to clean and demineralize all of the condensate before it is returned to the reactor vessel. In addition, modifications to the Condensate Polisher system were performed to install prefilters upstream of several polishers primarily for the removal of iron prior to passing through the associated polisher. Refer to Subsection 10.4.6.2.
- c. Provisions are made in the design of equipment and systems for the removal of crud before it settles on the surfaces. Such provisions consist of flushing lines and connections in most of the radioactive systems, and spargers in the radwaste tanks. Fuel pools are cleaned by pumping their water through filter/demineralizers, and mixing in the pools is achieved by separated locations of water outlet connections and inlet spargers.

12.3.1.8 Decontamination Facilities

Decontamination is important to keep the plant clean through several years of operation. The following features are provided to facilitate effective decontamination.

12.3.1.8.1 Coating

All concrete surfaces which have a potential for contamination are coated to a smooth nonporous finish. In general, floors and walls inside cubicles are coated to an 8-foot wainscot. Cubicles which house equipment and pipes carrying radioactive fluids at high pressures are fully

CPS/USAR

coated, including the ceiling. Many ceilings and walls above the wainscot are sealed to enhance decontamination and prevent dusting of the concrete.

Sinks provided in radchem laboratories and sample panels are constructed of stainless steel or other smooth, nonporous material.

12.3.1.8.2 Equipment Decontamination Facilities

A fully equipped equipment decontamination room is provided whose size and equipment are based upon experience from operating plants. Figure 12.3-37 gives the details of the equipment decontamination room. In addition, an equipment decontamination pit is provided on the turbine building main floor, and a fuel cask washdown area is provided in the fuel building. For dry cask storage operations in the fuel building the cask washdown area will be utilized for staging/preparation of the Transfer Cask/Multi-Purpose Canister (MPC) assembly for fuel loading, for closure of the MPC post fuel loading, and for decontamination of the Transfer Cask.

12.3.1.9 High Exposure Risk Operations

The following operations have a potential for high radiation exposures because of the presence of strong radiation sources and work in high radiation areas. Also included below are descriptions of design features employed to minimize risk.

12.3.1.9.1 Fuel Transfer

The spent fuel assemblies are the strongest radiation sources in the station. Special shielding and other design features are provided, as suggested in the Regulatory Guide 8.8, Section C.2.a(1), for the transfer of the spent fuel assemblies within the station, with the objective of minimizing the dose and the potential for inadvertent exposure to plant personnel. Following is a description of such design features.

- a. The fuel assemblies are moved under water in such a way that there is sufficient water shielding at all times to reduce the dose rate at the operator location to a few mrem/hr.
- b. An area radiation monitor is provided on both the refueling and fuel handling platforms and is interlinked with the crane hoist. The monitor acts to stop the upward movement of the hoist when the area radiation level exceeds a predetermined value. (See Subsection 12.3.4)
- c. In the vicinity of the refueling pool bellows, the water or concrete shielding is not sufficient to protect the people occupying certain areas of the drywell during the movement of irradiated fuel. Permanent lead shielding is provided in this area, which is 4 inches thick, encased in stainless steel, and covers a 180° sector around the fuel transfer gate. (See Drawing M01-1533-2) With this shielding in place permanently, the dose rates in the accessible areas of the drywell will not exceed 160 mrem/hr when the fuel assembly is passing over the bellows.

CPS/USAR

- d. The fuel transfer tube is shielded on all sides with concrete and/or steel shielding, as shown in Drawing M01-1533-2, such that the contact dose rates, on the shielding are limited to a few mrem/hr.
- e. There are two accessible areas within the transfer tube shielding envelope, one in the containment building and the other in the fuel building, as seen in Drawing M01-1533-2. There is an area radiation monitor with audible and visible alarms near the containment access shield. Access can be gained to these areas only through the removal of massive shield plugs. Access to these areas is administratively controlled. The following features are provided at the entrances to these areas to protect personnel from an inadvertent high exposure while they occupy these areas.
 - (i) Signs specified by 10CFR20.1902 are posted stating that potentially lethal radiation fields are possible inside during fuel transfer.
 - (ii) Interlocking mechanisms are provided between these shield plugs and the fuel transfer tube operating mechanism, such that the power to the transfer tube mechanism is cut off when either one of the shield plugs is removed. (Q&R 471.08)

12.3.1.9.2 Inservice Inspection

The inservice inspection (ISI) of the reactor pressure vessel (RPV) and its associated piping involves work in high-radiation areas. The CPS design employs the following features designed to minimize the time spent in high-radiation areas:

- a. Taking advantage of the 3-foot-wide annulus between the RPV and the reactor shield wall, provisions are made for ISI personnel to quickly enter the annulus and exit after mounting the ISI equipment.
- b. Galleries are provided inside the reactor shield wall for quick access to the ISI sites.
- c. Removable insulation sections are provided.

12.3.1.10 Radiation Protection Facilities

Sufficiently large radiation protection (RP) facilities are provided in the CPS design to enable an efficient operation of the RP program. Specific features are described below.

12.3.1.10.1 Radiation Protection Offices

The RP offices are located in the Administration Building. The office complex near the main entrance of the plant consists of the RP technician work area and RP Supervisor's office. The main access control point is visible from the RP technician work area.

12.3.1.10.2 Access Control Point

There are normally four personnel access control points into the Radiological Control Area (RCA) and two egress points from the RCA. Traffic patterns within the RCA will be established

CPS/USAR

along general access hallways having radiation zone designation A (<0.5 mrem/hr). Radiological access control is further described in Subsection 12.1.2.1.

12.3.1.10.3 Radchem Laboratories

The Chemistry laboratory complex is located on the 737' elevation of the Control Building. All the facilities have been sized based upon experience at operating plants, and have been laid out to permit an efficient operation.

All the surfaces are designed to be smooth and nonporous to facilitate decontamination. The ventilation system is designed to maintain a comfortable environment in these working areas. The radchem labs are maintained at a slightly negative pressure to keep any airborne contamination from escaping to the general areas.

12.3.1.10.4 Counting Room

The counting room, a part of the Chemistry laboratory Complex, is shielded on all sides to maintain a low background radiation level and make it less sensitive to changes in the radiation levels outside. Furthermore, the ventilation system is designed to supply filtered outside air and maintain a slightly positive pressure to help keep out any airborne contamination.

12.3.1.10.5 Laundry

The laundry facility designed for CPS is not currently in use (laundry services are provided by an off-site vendor). There is the capability to perform small scale laundry for clothing decontamination by the use of a home-size washer and dryer.

12.3.1.10.6 Personnel Decontamination and Change Rooms

As described in Subsection 12.1.2, personnel decontamination rooms have been provided in the vicinity of the machine shop and near the refuel floor access point. Their layout has been designed to maintain distinctly separate clean and contaminated areas, with special consideration given to personnel convenience. Privacy can be assured by appropriate scheduling and administrative controls.

12.3.1.10.7 Radiation Protection Instrument Calibration Facility

The Radiation Protection Instrument Calibration Facility is located along the east wall of the Control Building on the 737' elevation. The facility accommodates gamma sources (in-air and enclosed calibrators) and neutron sources. Some other sources are also used or stored in this area. The use and control of these sources is in accordance with the Operating License and/or station procedures. Room shielding consists of three 16-inch solid block concrete walls, a 20-inch thick floor, and a 12-inch thick ceiling (all nominal dimensions)

12.3.2 Shielding

12.3.2.1 Codes and Standards

Shielding is designed to enable plant operation with personnel exposures kept well within the requirements set forth in 10 CFR 20, and in accordance with the guidance provided in Regulatory Guide 8.8. The control room shielding is designed to meet Criterion 19 of 10 CFR

50, Appendix A. Concrete shields have been designed in accordance with the guidance provided in Regulatory Guide 1.69.

12.3.2.2 Design Bases

12.3.2.2.1 Operating Conditions

The control room and the containment building shielding are designed to meet accident conditions. All other shielding design is based upon normal operating conditions. Normal operating conditions are defined to include full-power operation, normal shutdown, refueling, testing and inservice inspection, and any abnormal occurrences that can be anticipated in connection with any of the above operations. Shielding for the individual components is designed for the particular operating condition which gives the highest radiation source inventory for the component. For example, shielding for the reactor water cleanup system is based upon full-power operation, while that for the residual heat removal system is based upon the initial stages of shutdown.

12.3.2.2.2 Radiation Sources

The radiation sources which form the basis of shielding design are discussed in Section 12.2.

12.3.2.2.3 Operating Experience

Experience from operating nuclear power plants has formed one of the bases for the shielding design. Most significantly, the knowledge of radioactive crud buildup at different places has resulted in several shielding changes, as discussed in Subsection 12.1.3.4. For components which handle highly radioactive fluids, the crud sources are insignificant, but in some cases they require the addition of shadow shield walls between redundant components located in the same cubicle. On the other hand, for components which handle slightly radioactive fluids, such as the condensate and floor drain tanks and pumps, the crud sources are significant, and frequently form the sole basis for shielding.

12.3.2.3 Design Criteria

Shielding is provided to meet the dose rate criterion of 0.5 mrem/hr in the general access areas of the plant. In addition, the design is also dedicated to reducing, in individual cubicles, the radiation levels which result from components located in adjacent cubicles. This latter feature of the shielding design is geared specifically to reducing maintenance exposures.

For cubicles where frequent maintenance access can be anticipated, such as the valve aisles and the pump cubicles, the shielding is designed to reduce the radiation levels to 2-5 mrem/hr. For the tanks and heat exchangers cubicles, the shielding is designed for approximately a 15-mrem/hr dose rate criterion.

12.3.2.4 Criteria for Penetrations in Shields

Shield penetrations (for pipe, cable trays, and entrances) compromise the shielding to some extent and create local hot spots. Efforts are made in the CPS design to minimize such hot spots by the use of labyrinths on entrances, and shielding and judicious locations for the penetrations. The following criteria are used for design:

CPS/USAR

- a. Labyrinths are provided on all necessary doorways, as discussed in Subsection 12.3.1.4.1. In some cases the entrances are covered with hatches. The design criterion used is that the dose rate shall not exceed 2-5 mrem/hr within local hot spots in the general access areas.
- b. The pipe, duct, and cable tray penetrations are located, to the extent practical, 10 feet off the floor of the general access areas, so that a person at the location is not affected by any direct radiation from the shielded sources.
- c. In many cases, penetrations are slanted at an angle to reduce radiation streaming.
- d. Shielding is provided between the pipe and the penetration sleeve, where necessary.

12.3.2.5 Shielding Materials

The primary shielding material used in the CPS is ordinary concrete. All the floors and slabs are made of poured-in-place concrete. Walls are either poured in place or built with concrete blocks. Poured concrete density is 140 lb/ft³, and concrete block density is 120 lb/ft³.

Other shielding materials used are water, steel and lead. Water is the basic shielding material for spent fuel and the drywell head area. Steel and lead shields are used only where space limitations do not permit the use of concrete.

The compositions, densities and neutron and gamma ray cross sections of these materials are taken from standard handbooks, and from the libraries built into the computer codes discussed in Subsection 12.3.2.6.

12.3.2.6 Calculational Techniques

Techniques employed for both the source and shielding calculations have been the standard techniques which are well recognized in the industry. Most of the calculations have been performed using computer codes available from the Radiation Shielding Information Center. Some special computer codes, which have been developed at Sargent & Lundy, have also been used in certain calculations. The various computer codes employed for calculations, their type, reference and typical uses are tabulated in Table 12.3-1.

12.3.2.7 CPS Shielding Design

The CPS shield wall and slab thicknesses are shown in Figure 12.3-40 and Drawings M01-1500, M01-1501, M01-1502, M01-1504, M01-1505, M01-1507, M01-1508, M01-1510, M01-1511, M01-1513, M01-1514, M01-1516, M01-1517, M01-1519, M01-1521, M01-1522, M01-1524, M01-1526, M01-1527, M01-1530, M01-1531, M01-1532, M01-1533, S27-1933, and S27-1934. The concrete used is of two different densities at different places as described in Subsection 12.3.2.5. The choice of the type of concrete is made based upon other than shielding considerations. Hence, the shielding drawings here give both the thickness based on 140-pcf density concrete and the "mass thicknesses" of concrete, which are defined as the products of multiplication of the thicknesses and densities. The correct thickness is arrived at by dividing the "mass thickness" by the correct density of concrete being used.

CPS/USAR

Figure 12.3-40 and Drawings M01-1500, M01-1501, M01-1502, M01-1504, M01-1505, M01-1507, M01-1508, M01-1510, M01-1511, M01-1513, M01-1514, M01-1516, M01-1517, M01-1519, M01-1521, M01-1522, M01-1524, M01-1526, M01-1527, M01-1530, M01-1531, M01-1532, M01-1533, S27-1933, and S27-1934 give the shielding requirements. The actual wall and slab thicknesses may be higher because of structural and other requirements.

12.3.2.8 Design and Evaluation of Drywell Penetrations

All routinely visited areas in the containment are designed to 2.5 mrem/hr with an allowable local hot spot criterion of 12.5 mrem/hr. These routinely visited areas include the following areas: reactor water cleanup and standby liquid control system, TIP station (personnel and equipment lock, dry-well penetrations, etc.), CRD hydraulic control units, the CRD master control and the containment personnel lock area. Drywell shield penetrations are described in Table 3.8-5.

The majority of drywell penetrations met the criteria for routinely visited areas in the containment by applying Penetration Screening Criteria for shielding (Reference 12). This calculation provided the historical methodology initially used for reviewing each of the drywell penetrations. The criteria used to screen out those penetrations that would not require a detailed, individual analysis are listed below:

- a. Penetrations filled with concrete-equivalent (for example, spare penetration sleeves).
- b. Electrical conduits which are sealed with appropriate radiation shielding/sealing material.
- c. Penetrations that terminate in a specially shielded high radiation zone area (for example the main steam tunnel).
- d. Penetrations that terminate in the suppression pool.
- e. Penetrations that are filled with water during reactor operation.
- f. Penetrations in which total radiation streaming is equal to or less than 12-1/2 mrem per hour.

Those drywell penetrations not meeting the above criteria required detailed, individual analysis to determine whether special shielding was required to reduce radiation streaming for routinely visited areas in the containment. Detailed analyses revealed that the allowable local hot spot criterion for routinely visited areas was satisfied for most of these penetrations.

The following shielding provisions have been made for specific drywell penetrations (or types of penetrations) in order to meet the criteria for routinely visited areas in the containment:

- a. The drywell personnel and equipment hatches are shielded by 4 foot-6 inch thick removable reinforced concrete slabs, as shown in Drawing M01-1510.
- b. The drywell head penetration is shielded with water, as shown in Drawing M01-1533.
- c. The drywell vacuum breakers include compensatory shielding to reduce radiation streaming to acceptable dose rate levels, where necessary.

CPS/USAR

- d. The manhole penetration is shielded with a cover.
- e. The annular gap between the penetration sleeves and the pipes going through them are filled with a concrete-equivalent shielding material.

12.3.3 Ventilation

12.3.3.1 Design Objectives

The design of station ventilation systems is designed to achieve the following objectives:

- a. Provide environmental conditions suitable for operating personnel and equipment.
- b. Provide effective protection for operating personnel by removing potential airborne radioactivity from areas where it may occur by maintaining air flow from clean areas to areas of progressively greater potential for contamination.
- c. Ensure that the maximum airborne activity levels are within the limits of 10 CFR 20, Appendix B, and are as low as reasonably achievable (ALARA) per Regulatory Guide 8.8.
- d. Ensure compliance with normal operation offsite release limits in accordance with 10 CFR 20, Appendix B, and 10 CFR 50, Appendix I.
- e. Provide a suitable environment for equipment and continuous personnel occupancy in the main control room under post-accident conditions in accordance with 10 CFR 50, Appendix A, Criterion 19, and Regulatory Guide 1.52.

12.3.3.2 Design Criteria

The following general guidelines are incorporated in the systems to accomplish the design objectives:

- a. Airflow patterns are maintained such that air flows from areas of low potential airborne radioactivity to areas of higher potential airborne radioactivity. Exhaust is through filters, if necessary.
- b. The staging of air from one cubicle to another has been avoided to the extent practicable. This has been done to prevent the spread of airborne radioactivity.
- c. As a minimum, the quantity of airflow is designed to maintain potential airborne radioactivity below 30% of the Derived Air Concentration as described in the tables of Subsection 12.2.2.
- d. A negative pressure differential, with respect to surrounding areas is maintained inside potentially contaminated cubicles by means of backdraft dampers or airflow patterns.
- e. Fume hoods or direct connections to sample panel fans, at sample stations and at sample panels, are utilized in the laboratories to facilitate safe processing of

CPS/USAR

radioactive samples by directing contaminants away from the breathing zone to the filtering and ventilation system.

- f. Equipment decontamination facilities are ventilated to ensure control of released contamination and prevent personnel exposure and the spread of contamination.
- g. Exhaust air is routed through HEPA filters or a combination of HEPA and charcoal filters where necessary before release to the atmosphere to minimize onsite and offsite radioactivity levels.
- h. Air is supplied to each principal building via separate supply intakes and duct systems to prevent the spread of airborne radioactivity from one building to another.
- i. The fresh air supply to the control room is designed to be operable during loss of offsite power. The air is filtered and can be passed through charcoal adsorbers to prevent contamination of the control room by excessive radioactive material
- j. All exhaust treatment systems designed to handle potentially contaminated air in the plant are of similar design. A typical filtration system is equipped with a demister and/or prefilter, a set of prefilters, and a set of HEPA filters. In addition, filter systems designed to remove radioiodine are equipped with a charcoal filter bank, a heater for humidity control, and a second set of HEPA filters to collect charcoal fines emerging from the charcoal filters. Dampers are provided before and after the filter train to isolate the train during filter changes. See Figure 12.3-64 for typical filter package.
- k. All filter systems in which radioactive materials could accumulate to produce significant radiation fields external to the ductwork are designed to be easily maintained and appropriately located and shielded to minimize exposure to personnel and equipment.
- l. Filters in all systems are designed to be easily changed if airflow is too low or the pressure drop across the filter bank is excessive. In the case of the prefilters, a pressure drop of 1 inch of water equivalent across the bank is cause for changeout. HEPA filters are changed when the pressure drop across the HEPA filters reaches 2 inches of water equivalent. Charcoal adsorbers are changed based on the residual adsorption capacity of the bed as measured by test samples or canisters which are to be periodically removed for analysis.
- m. While the majority of the activity in the filter train is removed by simply removing the contaminated filters, further decontamination of the internal structure is facilitated by the proximity of electrical outlets for operation of decontamination equipment, and water supply for washdown of the interior, if necessary. Drains are provided on the filter housing for removal of contaminated water.

The detailed design of the heating, ventilating, and air conditioning systems are described in Section 9.4.

Conformance with Regulatory Guide 1.52 is provided in Table 6.5-3.

Conformance with other Regulatory Guides is contained in Section 1.8 of this USAR.

12.3.3.3 Special Ventilation Design Features

12.3.3.3.1 Control Room Ventilation

Two, 100% capacity, redundant HVAC systems with a common duct and controls set to ensure habitability and integrity of equipment and components inside the control room and other areas served by the system under all the station conditions. Outside air is supplied from one of the two separate air intake louvers, each capable of providing 100% supply air. A radiation monitoring system is provided to monitor the radiation levels in the control room and outside air intakes. A high radiation signal in the outside air intake alarms in the control room, closes the normal supply of outside air to the control room, and automatically starts one of the two redundant emergency HEPA and charcoal filter trains for removal of contamination from the outside air before it is supplied to the control room HVAC system. A slightly positive pressure is maintained in the main control room to prevent infiltration of potential contaminants.

A complete description of the control room system is found in Subsection 9.4.1.

12.3.3.3.2 Drywell Purge System

The drywell purge system is designed to purge the drywell at a nominal rate of greater than three air changes per hour. The containment building can also be purged through this system when necessary. The purged air is filtered through HEPA and charcoal filters and exhausted to the common station HVAC vent where it is monitored for radioactivity. The drywell atmosphere can be purged through the standby gas treatment system, if necessary.

A complete description of drywell cooling and purge system is given in Subsection 9.4.7.

12.3.3.3.3 Containment Building Ventilation and Purge Systems

12.3.3.3.3.1 Containment Building Ventilation System

The containment building ventilation system serves the containment building during plant refueling, cold shutdown, normal plant operation, and before and during drywell occupancy for pressure control, ALARA, or air quality considerations for personnel entry. The outside air is filtered, tempered, and delivered to different areas through a supply air duct system. Most of the air travels to the operating floor where it is exhausted through vents embedded in the fuel pool interior walls just above the water level. The air exhausted from the pools is monitored for radiation. The ducts between this monitor and the containment building isolation damper are sized to prevent release of radioactivity during the damper closure time. An exhaust air duct system and fans are used to exhaust the containment building ventilation air to the common station HVAC vent where it is monitored for radiation. The air movement is directed from areas of lower contamination potential to areas of higher contamination potential. The containment building negative pressure, with respect to outside, is maintained by damper control.

Equipment and piping heat removal from the containment building is accomplished by providing air handling and fan-coil units in individual areas. These air handling units and fan-coil units are served by the plant chilled water system.

The containment building exhaust air can be purged through the drywell purge units if necessary, to remove radioactivity.

A complete description of the containment building ventilation system is given in Subsection 9.4.6.

12.3.3.3.3.2 Continuous Containment Purge System

The continuous containment purge system serves the containment building during plant refueling, cold shutdown, and normal plant operation. The outside air is filtered, tempered, and delivered to general areas through a supply air piping and ductwork system. Air flows from general areas to equipment cubicles from which it is exhausted. The purge air exhausted is monitored for radiation. High radiation signals isolate the purge lines supply and exhaust isolation valves. An exhaust air piping system and blowers are used to exhaust the containment building purge air to the common station HVAC vent where it is sampled for radiation. The containment building negative pressure, with respect to outside, is maintained by a pressure control damper.

Equipment and piping heat removal from the containment building is accomplished by providing air handling and fan-coil units in individual areas. These air handling units and fan-coil units are served by the plant chilled water system.

The containment building exhaust air can be purged through two of the three drywell purge units if necessary, to remove radioactivity.

A complete description of the continuous containment purge system is given in Subsection 9.4.6.

12.3.3.3.4 Radwaste Building Ventilation

The radwaste building ventilation system serves the radwaste building. The outside air is filtered, tempered, and delivered in different areas through a supply air duct system. An exhaust air duct system and fans are used to exhaust the radwaste building ventilation air to the common station HVAC vent where it is monitored for radiation. The airflow is maintained from clean areas to potentially contaminated areas. The radwaste building negative pressure, with respect to outside is maintained by damper control. Sump and tank vents, ducted directly to the exhaust ductwork, reduce the amount of airborne radioactivity within plant areas.

Fan-coil units and air handling units served by the plant chilled water system are utilized to dissipate heat from piping, valves, and equipment in generally accessible areas and cubicles.

A complete description of the radwaste building ventilation system is found in Subsection 9.4.13.

12.3.3.3.5 Fuel Building Ventilation

The fuel building ventilation system serves the fuel building and that part of the auxiliary building within the secondary containment. Outside air is filtered, tempered, and delivered to different areas via a supply air duct system. An exhaust air duct system and fans are used to exhaust the fuel building ventilation air to the common station HVAC vent where it is monitored for radioactivity. The air movement is maintained from clean areas to potentially contaminated

areas. The fuel building is maintained at a negative pressure, with respect to outside, by damper control.

Some of the supply air is distributed to the main floor where it is subsequently exhausted through vents embedded in the fuel pool interior walls, just above the water level. The air exhausted from the pools is monitored for radiation. Upon detection of high radiation, this duct monitor actuates an alarm in the main control room, isolates the fuel building HVAC system, and starts the standby gas treatment system. The ducts between this monitor and the fuel building isolation damper are sized to prevent a release of radioactivity during the damper closure time.

The equipment and piping heat removal from the fuel building is accomplished by providing fan-coil units in individual areas. The fan-coil units are served by the station chilled water system.

A complete description of the fuel building ventilation system is given in Subsection 9.4.2.

12.3.3.3.6 Laboratory System

The laboratory HVAC system serves the laundry area, laboratory area, bioassay area (including storage rooms, laboratory and offices) and the counting room. Outside air is filtered, tempered, and delivered to different areas via a supply air duct system. A separate redundant HVAC system is provided for the counting room. This system supplies 100% outside air which is cleaned with HEPA filters and tempered for the counting room.

12.3.3.3.7 Standby Gas Treatment System

The standby gas treatment system serves to keep the secondary containment under negative pressure. This is done by exhausting air from the fuel building, auxiliary building, and the containment gas control boundary. The standby gas treatment system also is a backup to the combustible gas control system.

12.3.3.3.8 Auxiliary Building Ventilation

The auxiliary building ventilation system serves that part of the auxiliary building outside of secondary containment and portions of the control building. The outside air is filtered, tempered, and delivered to different areas via a supply air duct system. An exhaust air duct system and fans are used to exhaust the auxiliary building ventilation air to the common station HVAC vent where it is monitored for radioactivity. The airflow is maintained from clean areas to potentially contaminated areas. The Auxiliary Building and Control Building general access areas are maintained at an ambient or slightly positive pressure, with respect to outside, by damper control, while some areas within the buildings are maintained at a negative pressure, with respect to adjacent areas, to control airborne radioactivity. Process sampling panel vents and potential radioactive tank vents, (except those in secondary containment), ducted directly to the exhaust ductwork, reduce the amount of airborne radioactivity within plant areas.

Fan-coil units and air handling units served by the plant chilled water system are utilized to dissipate heat from piping, valves, and equipment in generally accessible areas and cubicles.

A complete description of the auxiliary building ventilation system is found in Subsection 9.4.3.

12.3.4 Area Radiation and Airborne Radioactivity Monitoring Instrumentation

The following systems are provided to monitor radiation/radioactivity levels within the plant:

- a. fixed and portable area radiation monitors (ARM's);
- b. fixed and portable continuous airborne radioactivity monitors (CAM's); and
- c. special application instrumentation.

The ARM's are provided to continuously measure, indicate, and record the levels of radiation and to activate alarms when predetermined levels are exceeded. The general objective is to keep operating personnel informed of the radiation levels in the selected areas and thus assist in avoiding unnecessary or inadvertent exposure.

The CAM's are provided to measure, indicate, and record the levels of airborne radioactivity at locations where airborne radioactivity is likely. Each CAM actuates an alarm when preset levels are exceeded. Portable CAM's, personnel lapel air samplers or air samples by Radiation Protection personnel may be utilized to monitor for airborne radioactivity in work areas where the potential exists to exceed expected levels by a significant margin.

Fixed CAM's provide a means for sampling ducts in the plant to provide information regarding the presence of airborne contamination in plant cubicles.

Special application area radiation monitors are provided for the containment building polar crane, containment building fuel handling platform, the fuel building fuel handling platform, and the new fuel storage vault. The purpose is to alert operating personnel to potentially hazardous conditions associated with fuel handling and storage. Containment Building post-accident radiation monitoring is performed by the high range gamma radiation monitoring system, which is a subsystem of the containment atmosphere monitoring system and is discussed in Subsection 7.6.1.10.

12.3.4.1 Area Radiation Monitoring Instrumentation

The ARMs which communicate with the central control terminal are provided to fulfill the following specific radiological design objectives (stand-alone ARMs fulfill objectives b, e, and f):

- a. Provide warning in the Main Control Room in the event that preset gamma radiation levels are exceeded in work areas where radioactive materials may be stored or handled.
- b. Provide local alarms and indicators at key points where radiation levels might be of immediate importance to personnel in or entering the area.
- c. Provide operating personnel with indication and a record in the Main Control Room of radiation levels at selected locations throughout the plant. Data is also available at a CRT on work station 1CX16J in the Plant Process Computer Room.
- d. Provide information to Main Control Room operators, and support personnel to assist in making decisions for deployment of personnel in the event of an excessive increase of radiation levels in the plant.

CPS/USAR

- e. Supplement other systems, including Process Radiation Monitoring and Leak Detection, in detecting abnormal leakage of any radioactive material from the process streams.
- f. Assist in maintaining exposure to personnel as low as is reasonably achievable (ALARA).
- g. Interlock the raising control circuits of the hoists of each of the fuel handling bridges and Polar Crane. This safety interlock functions to limit the radiation dose rates to personnel on the refuel floor during the hoist raising of reactor components.

To implement these objectives, fixed area radiation monitors are provided throughout the plant at locations indicated in Table 12.3-2. Portable area radiation monitors may be placed in any plant location. They may operate as stand alone units or be tied in with the central control terminal via a communication plug.

12.3.4.1.1 Area Radiation Monitoring Equipment Design

12.3.4.1.1.1 Energy Dependence

The reading in mr/hr is within $\pm 20\%$ of the actual exposure rate over a gamma radiation energy range of 0.195 to 1.2 MeV.

12.3.4.1.1.2 Range

ARMs have a range of 10^{-1} to 2.2×10^3 mR/hr. The microprocessor associated with each ARM is designed to accept input from a second detector with a range from 10^1 to 10^4 R/hr.

12.3.4.1.1.3 Sensitivity

ARMs have a sensitivity of 84 ± 14 cpm/mR/hr on the lower range and 800 cpm/R/hr on the extended range discussed in Section 12.3.4.1.1.2.

12.3.4.1.1.4 Setpoints

Alarm setpoints are established and controlled based upon design and/or actual radiation levels.

12.3.4.1.1.5 Power Supply

Fixed ARMs receive power from a (non-essential) 120-Vac instrument bus. Portable ARMs receive power from 120-Vac convenience outlets. All ARMs have integral battery power backup which can provide eight hours of operation as described in 12.3.4.1.2.

12.3.4.1.1.6 Calibration

ARMs are periodically calibrated to an NBS traceable source using fixed geometry. For ARMs listed in the Operational Requirements Manual (ORM) the calibration frequency is as listed. For all other ARMs the calibration frequency is determined by Plant Engineering personnel.

CPS/USAR

Channel operation checks may be done at any time by substitution of an electronic pulse generator for the detector or by actuating a check source mechanism by controls located locally or in the main control room.

12.3.4.1.2 Area Radiation Monitoring Instrumentation Description

Each ARM consists of a GM tube detector and a local digital processor. Certain fixed ARMs communicate with the central control terminal located in the main control room. Portable ARMs may be connected to communication outlets located throughout the plant to communicate with the central control terminal. All ARMs are capable of stand-alone operation.

Refer to Table 12.3-2 for a listing of ARMs that are

- a. Stand-alone operation only.
- b. Normally are operated in stand-alone mode but can communicate with central control terminal.

The local digital processor displays the most current reading and maintains a history data file. Status lights are provided. Locally, a visual and an audible alarm are actuated when the high radiation setpoint is exceeded or upon failure of the ARM.

ARM data and status (including alarms) are provided to the central control terminal via digital communication links. Current and historical data are available on the main control room central control terminal.

Each fixed digital ARM (or portable digital ARM connected to a communication plug) is independent and is isolated from the central control terminal and other digital ARM's by optical isolators in the communication links.

On loss of 120Vac power, digital ARM's continue to function as described except that local audible and visual alarms cannot be actuated. The status lights will, however, indicate alarms.

12.3.4.1.3 Functioning of ARM's During and After an Accident

Most of the area monitors will be expected to remain serviceable and provide personnel with the capability to access the potential radiation hazards in the plant following accidents. It is expected that most areas which may require access following an accident will be less than 10 R/hr (the upper detection limit of most ARMs). In addition, the digital microprocessor associated with each ARM is designed to accept input from a second high range detector with a range of 10^1 to 10^4 R/hr. High range detectors can be added as needed. A high fail alarm (off scale) will be received locally and at the main control room if the ARM is connected to a communication plug. Area monitors can be readily checked with a portable survey meter to see if they are operating properly.

12.3.4.2 Continuous Airborne Radioactivity Monitoring Instrumentation

Constant air monitors (CAM) are provided to fulfill the following radiological design objectives:

CPS/USAR

- a. Provide ambient air monitoring for detecting airborne particulate radiation, iodine, and noble gases in plant areas or cubicles.
- b. Provide capability to monitor air in ventilation ducts or process lines to detect radioactivity which may be released due to malfunctions of equipment. Taps for connecting the portable CAM's are provided at selected locations throughout the plant.

Fixed (in-place) CAM's are permanently connected in selected exhaust ventilation ducts to measure airborne radioactivity in those ducts and alarm when it exceeds a fraction of the derived airborne concentration for radionuclides of interest (considering dilution of airborne radioactivity in individual station areas before it reaches the monitored duct). The portable CAM's may be used to locate and monitor the specific cubicle responsible for the increased activity if a fixed CAM indicates significant airborne contamination. The portable CAM's may also be used for ambient air monitoring.

12.3.4.2.1 Continuous Airborne Radioactivity Monitoring Equipment Design

12.3.4.2.1.1 Detector Types, Ranges, and Alarms

Detector types, ranges, and alarm setpoints are presented in Table 12.3-3.

12.3.4.2.1.2 Power Supply

Power for fixed CAM's is from a 120-Vac (non-essential) instrument bus. Power for portable CAMs is from 120-Vac convenience outlets.

12.3.4.2.1.3 Calibration

Each channel is calibrated using NBS traceable standards at intervals recommended by the manufacturer or established by engineering evaluation. Special calibration factors may be determined from laboratory isotopic analysis of grab samples taken from the monitored process stream. Operational checks are as described for the ARM's in Subsection 12.3.4.1.1.6.

12.3.4.2.1.4 Sample Lines

Sample lines have been designed, fabricated, and installed to meet the recommendations of ANSI N13.1 and minimize sample plateout, to the extent practical. The location of the CAM sample probe has been chosen to minimize the potential for moisture in the duct air to foul the monitor's filters.

12.3.4.2.2 Continuous Airborne Radioactivity Monitoring Instrumentation System Description

Each CAM consists of five detectors and a local digital processor.

Three detectors are provided on each CAM to monitor different species:

- a. Particulate: beta scintillation detector.
- b. Iodine: gamma scintillation detector, gain stabilized with adjacent channel for subtraction of noble gas contribution.

CPS/USAR

- c. Noble gas: beta scintillation detector.

Two detectors are provided on each CAM to measure background radiation:

- a. Gamma (external): G-M tube detector.
- b. Alpha (naturally occurring Rn and Th): alpha scintillation detector.

The local digital processor provides conversion of detector outputs to radioactivity concentrations using correlation coefficients determined from calibrations. Digital displays of particulate iodine activity deposited on the filters (μCi), and noble gas concentrations ($\mu\text{Ci/cc}$) (corrected for background) are available locally or at the central terminal.

Refer to Table 12.3-4 for a listing of CAMs that are;

- a. Stand-alone operation only.
- b. Normally are operated in stand-alone mode but can communicate with central control terminal.

Time-based rate-of-rise for particulates, iodine and noble gas may be displayed at the central control terminal. The local processor maintains a history data file. In addition, portable CAM's contain a strip chart recorder for recording the three detector outputs of particulate, iodine, and noble gas. Status lights are provided.

A visual and an audible alarm are actuated when the alert or high radiation setpoint of any channel (except background channels) is exceeded. A visual and an audible alarm are also actuated upon failure of a CAM channel.

CAM data and status (including alarms) may be provided to the central control terminal in the Main Control Room via digital communication link for certain fixed CAM (or portable CAM when connected to a communication plug). CAM data is only available locally for those CAMs which are operating in the stand-alone mode, see Table 12.3-4.

Each fixed CAM (or portable CAM connected to a communication plug) is independent and is electrically isolated from the central control terminal and other CAMs by optical isolators in the communication links. Each CAM is capable of stand-alone operation.

The fixed and portable CAMs communicate with the central control terminal and portable control terminals as described in Subsection 12.3.4.1.2 for the fixed and portable ARMs.

12.3.4.2.3 Criteria for Continuous Airborne Radioactivity Monitoring Locations

Locations for continuous Airborne Radiation Monitors are determined based upon the following criteria:

- a. Areas or cubicles are to be monitored where personnel are present or may wish to enter with capability of detecting maximum Derived Air Concentrations (DAC) of particulates and iodines in 10 hours or less.

CPS/USAR

- b. Provide capability to determine radioactivity source location if the occurrence of significant rise in airborne radioactivity is indicated.
- c. Areas are to be monitored to detect radioactivity which may be released due to malfunctions of equipment.

12.3.4.2.3.1 Selection of Locations for Fixed Continuous Airborne Monitoring Locations

Fixed (in-place) CAM's are provided to fulfill the first and third criteria listed in Subsection 12.3.4.2.3. Fixed CAM's are provided for the following buildings:

- a. auxiliary building,
- b. fuel building,
- c. control building,
- d. containment building,
- e. turbine building,
- f. radwaste building, and
- g. technical support center.

The location of the fixed CAM's and the areas sampled by them are listed in Table 12.3-4. Each CAM monitors selected exhaust ducts for the building at points upstream of any filters and isolation valves. The sample point for each monitor was chosen based upon assessments of potential contamination in areas or cubicles, ventilation air flow rate, and the lower limit of detectability of monitors.

12.3.4.2.3.2 Selection of Locations for Portable Continuous Airborne Radioactivity Monitors

Sample taps are provided in HVAC ducts for connection of portable CAM's to fulfill the second criterion listed in Subsection 12.3.4.2.3. The locations of these sample taps are listed in Table 12.3-6.

12.3.4.2.4 Functioning of CAM's During and After an Accident

The CAM's are not designed to operate in high radiation backgrounds or to monitor high airborne activity levels. For example, a 10 Rem/hr background would saturate all monitor channels. Also particulate and iodine air concentrations corresponding to the range (which may be orders of magnitude below accident concentrations) limits would saturate the detectors in minutes.

Nevertheless, some of the monitors would remain serviceable and be useful for the purpose of protecting operating personnel in the event of an accident. For example, the noble gas monitor range extends to 3.7×10^{-2} $\mu\text{Ci/cc}$, a concentration which would seriously limit or prohibit access, even with respiratory protection. Most areas which would require access after an accident would not be expected to experience or sustain such high levels..

Thus, in some areas, the monitors may be operating satisfactorily, or portable monitors moved in, to provide personnel with the capability to continuously assess airborne hazards in areas which may require access during the course of an accident. In addition, sample points for portable CAM's are located in general access areas so that cubicles with high background radiation may be monitored remotely.

Portable survey meters can be used to see if monitors are functional and can be used.

12.3.4.3 Special Application Instrumentation

Radiation monitoring instrumentation is also provided for accident considerations to interlock fuel handling equipment under abnormal conditions. High-range instrumentation, as in the Containment Atmosphere Monitoring System, is discussed in Section 7.6. A fixed CAM is provided to monitor the drywell atmosphere to supplement the leak detection monitor described in Subsection 5.2.5.

12.3.4.3.1 Fuel Handling Equipment Associated Monitors

Two monitors are provided to interlock the raising control circuits of the hoists of the fuel building fuel handling platform and containment building fuel handling platform. Another monitor is provided on the operating cabin of the containment building polar crane to warn the operator of high radiation and to interlock with the lifting mechanism to prevent further lifting in the event of radiation detection at or above a pre-established level. These monitors are provided for the safety of the crane operator. The instrument numbers and locations are provided in Table 12.3-2.

12.3.4.3.1.1 Equipment Design

The radiation monitoring instrumentation consists of one GM tube detector and a local analog indicator trip unit. Energy dependence is as described in Subsection 12.3.4.1.1.1. Range of these monitors is 0.1 to 2.2×10^3 mR/hr. Power is supplied from the source supplying power for the controls and interlocks of the associated crane or platform. Calibration is as described in Subsection 12.3.4.1.1.6 except that channel operational checks may only be done from local controls.

Analog indication for the monitors is provided near the operator controls for the associated crane or platform. A local audible and visual alarms are provided for each monitor on the indicator trip unit.

The monitors are independent of each other and do not communicate with the central control terminal previously described.

12.3.4.4 Conformance to Specific Regulatory Requirements

12.3.4.4.1 Regulatory Guide 8.2

Compliance is achieved by incorporating the guidance supplied by this regulatory guide into station procedures, with the exception noted in Section 1.8.

CPS/USAR

12.3.4.4.2 Regulatory Guide 8.8

12.3.4.4.2.1 Position C.2.G

Compliance is achieved by providing a central monitoring system which provides readout capability at the main control room.

Placement of detectors is provided to obtain optimum coverage of the areas.

Failure and high radiation alarms and radiation or radioactivity concentration data are provided for readout locally.

Ranges have been chosen on all monitors to provide indication, with sufficient margin, of the highest anticipated radiation levels and to ensure positive readout at the lowest anticipated levels consistent with the available instrumentation.

12.3.4.4.2.2 Position 4B

Portable area radiation monitoring equipment described in Section 12.3.4.1.1 provides indications of 10^{-1} to 2.2×10^3 mR/hr. Portable CAM's described in Subsection 12.3.4.2 provide sampling for short-term use. Monitors are provided with particulate filters and iodine cartridges.

12.3.4.4.3 Regulatory Guide 8.12

Compliance to this Regulatory Guide is discussed in Section 1.8.

12.3.4.5 Compliance with Industry Standards

12.3.4.5.1 ANSI N13.1

12.3.4.5.1.1 Representative Samples

Sampling in a zone occupied by workers will be done insofar as practicable in accordance with the recommendations given. Sampling from ventilation ducts is done in general conformance with the guides. In all cases in-line mounted sample probes with sample transport lines between the probe and the monitor are provided. Flow is measured at the monitor itself, giving a correlation between the duct flow and the sample flow rates.

12.3.4.5.1.2 Methods

Sampling from ducts is provided by placing probes in the ducts with sampling lines to the monitor. Particulate filters and iodine cartridges are provided on the monitors. Flow measuring rotameters are provided downstream of all sampling filters. These rotameters have been calibrated to a standard instrument. Pressure measurement is provided at the rotameter to provide correction of reading to standard conditions. Flow regulators are provided to control the flow through the filters at a constant rate.

12.3.4.5.1.3 Validation of Sampling Effectiveness

Data from the radiation monitors is periodically checked against analysis data obtained from laboratory analysis of grab samples.

CPS/USAR

12.3.5 References

1. M. Kaiseruddin, "Labyrinth Design in Nuclear Power Plants", Proceedings of the special session on plant and equipment design features for radiation protection, ANS-SD-15 (1975).
2. D. L. Strenge, M. M. Hendrickson, and E. C. Watson, "RACER A Computer Program for Calculating Potential External Dose from Airborne Fission Products Following Postulated Reactor Accidents," BNWL-B-69, Battelle Memorial Institute, Pacific Northwest Laboratories, Richland, Washington, 1971.
3. D. J. Pichurski, "A Program to Compute Radioactive Decay in Fluid Flow Systems," Sargent & Lundy Program No. 9.8.060-1.0, 1976.
4. R. L. Engle, J. Greenborg, and M. M. Hendrickson, "ISOSHLA A Computer Code for General-Purpose Isotope Shielding Analysis," BNWL-236, Pacific Northwest Laboratory, Richland, Washington, June 1966; Supplement 1, March 1967; Supplement 2, April 1969.
5. R. E. Malenfant, "QAD: A Series of Point-Kernel General Purpose Shielding Programs," LA-3573, Los Alamos Scientific Laboratory, April 5, 1967.
6. R. E. Malenfant, "G³: A General-Purpose Gamma-Ray Scattering Program," LA-5176, Los Alamos Scientific Laboratory, June 1973.
7. W. W. Engle, Jr., "A Users Manual for ANISN, A One Dimensional Discrete-Ordinates Transport Code with Anisotropic Scattering," K-1693, Union Carbide Corporation, Nuclear Division, March 30, 1967.
8. S. T. Weinstein, "NAC: Neutron Activation Code," NASA TM X-52460, Lewis Research Center, 1968.
9. J. H. Price, D. G. Collins, and M. B. Wells, "SKYSHINE - A Computer Program for the Monte Carlo Integration of 6-MeV Gamma Ray Transmission, Reflection, and Air Scattered Data to Compute Dose Rates," RRA-N760S, Radiation Research Associates, 1979.
10. NUREG-0016, Rev. 1, "Calculation of Releases of Radioactive Materials in Gaseous and Liquid Effluents from Boiling Water Reactors (BWR-GALE Code)," U.S. Nuclear Regulatory Commission, 1979.
11. R. S. Hubner, "CONLAB - A BWR Power Plant Dose After Design Basis Accident Code," Sargent & Lundy Program No. 09.8.057-12, 1978.
12. Calculation NB-015, "Clinton Drywell Penetration Review".
13. GE BWR Owners' Group Report MPR-2392, "Radiation Monitoring System Reliability Improvements for Boiling Water Reactors," September 10, 2002.
14. DC-ME-05-CP, Clinton Power Station Unit 1 "Radiation Protection Design Criteria Radiation Shielding & Access Control," Sargent & Lundy

CPS/USAR

15. MCNP, S&L Computer Program No. 03.7.511-4.0C, "MCNP-4C3 Monte Carlo N-Particle Transport Code System," July 2002
16. MicroShield, S&L Program No. 03.7.508-5.05, Version 5.05

CPS/USAR

TABLE 12.3-1
COMPUTER CODES USED IN SHIELDING DESIGN

| NAME | REFERENCE | TYPE | TYPICAL USE |
|-------------|-----------|------------------------------------|-----------------------------------|
| RACER | 2 | Accumulation and decay | Post-LOCA distribution of sources |
| DIJESTER | 3 | Accumulation and decay | Liquid radwaste sources |
| ISOSHLD | 4 | Point kernel with buildup | Shielding walls and slabs |
| QAD | 5 | Point kernel with buildup | Shielding walls and slabs |
| GGG | 6 | Single scatter | Labyrinths and penetrations |
| ANISN | 7 | One-dimensional discrete ordinates | Reactor shield wall |
| NAC | 8 | Neutron activation | Activation of separators |
| SKYSHINE | 9 | Monte Carlo | Skyshine |
| BWR-GALE | 10 | Expected release | Radioactive releases |
| CONLAB | 11 | Finite cloud immersion | Control room dose |
| MCNP | 15 | Monte Carlo | Direct and Scatter Dose Rates |
| MicroShield | 16 | Point Kernel | Shielding Dose Rates |

CPS/USAR

TABLE 12.3-2
LOCATIONS OF FIXED AREA RADIATION MONITORS

| INSTRUMENT NUMBER | SERVICE/AREA COVERED | APPROXIMATE LOCATION (ELEVATION/COLUMN/ROW) |
|-----------------------------|-----------------------------------|---|
| <u>Auxiliary Building</u> | | |
| 1RE-AR010 | Outside RHR B Equipment Room Area | 737/U/105 |
| 1RE-AR013 | Outside RCIC Equipment Room Area | 707/U/114 |
| <u>Control Building</u> | | |
| 1RE-AR035 | Control Room | 800/V/128 |
| <u>Fuel Building</u> | | |
| 1RE-AR019 | New Fuel Storage Area | 755/AK-AL/112 |
| 1RE-AR052 | New Fuel Storage Area | 755/AK/110 |
| 1RE-AR016 | Spent Fuel Storage Area | 755/AH/121 |
| *1RE-AR024 | Fuel Bldg. Fuel Handling Platform | 755 |
| <u>Containment Building</u> | | |
| 1RE-AR001 | CRD Hydraulic Units East Side | 755/AD/121 |
| 1RE-AR002 | CRD Hydraulic Units West Side | 755/AD-AE/104.5 |
| 1RE-AR012 | Containment Elevation 737'-0" | 737/AC-AD/107 |
| 1RE-AR003 | Tip Drive Mechanism Area | 737/AB-AC/117 |
| *1RE-AR025 | Containment Polar Crane | 828 |
| *1RE-AR037 | Containment Refueling Platform | 828 |

* These are analog ARMS that operate in stand-alone mode only and are not connected to the central control terminal. They provide local alarms and annunciation only.

CPS/USAR

TABLE 12.3-3
CONTINUOUS AIRBORNE RADIOACTIVITY MONITOR
CHANNEL CHARACTERISTICS

| CHANNEL | DETECTOR TYPE | NOMINAL RANGE | ALARMS AND TRIPS |
|-------------|--|--|--------------------------------|
| Particulate | Beta Scintillation | 8.1×10^{-12} to 1.2×10^{-7} $\mu\text{Ci/cc}$ | Fail Alert High Trend |
| Iodine | Gamma Scintillation (Sodium Iodide) | 9.43×10^{-12} to 3.71×10^{-7} $\mu\text{Ci/cc}$ | Fail Alert High Trend |
| Noble Gas | Beta Scintillation | 8.4×10^{-7} to 3.7×10^{-2} $\mu\text{Ci/cc}$ | Fail Alert High Trend |

CPS/USAR

TABLE 12.3-4
LOCATIONS OF FIXED CONTINUOUS AIRBORNE RADIOACTIVITY MONITORS

| Monitor Number | Description | Areas Sampled | Duct Flow Rate (CFM) | Skid Location Elev./Col./Row |
|----------------|-----------------------------|-----------------------------------|----------------------|------------------------------|
| **1PR13S | Turbine Building CAM #4 | Turbine Bldg. Ventilation Exhaust | 52,100 | 737/S/129.7 |
| **1PR18S | Auxiliary Building CAM | Aux. Bldg. Ventilation Exhaust | 16,600 | 781/AF/124 |
| **1PR19S | Fuel Building CAM | Fuel Bldg. Ventilation Exhaust | 24,000 | 781/AE-AF/124 |
| **1PR20S | Control Building CAM | Laboratory Ventilation Exhaust | 32,900 | 762/V/128 |
| 1PR23S | Containment Building CAM #3 | Leak Detection | Not Applicable | 803-3/AZ.50° |
| *1PR043 | TSC CAM | TSC | Not Applicable | TSC Document Room |

* This CAM is normally operated in the stand-alone mode and is not polled by the central control terminal. It provides local alarms and annunciation only, when operated in the stand-alone mode.

** These CAMs are operated in the stand-alone mode only and are not connected to the central control terminal. They provide local alarms and annunciation only.

NOTE: TABLE 12.3-5 has been deleted. USAR Table 3.8-5 shows the drywell penetrations.

CPS/USAR

TABLE 12.3-6
SAMPLE TAPS FOR USE WITH PORTABLE
CONTINUOUS AIRBORNE RADIOACTIVITY MONITORS

| PORTABLE CAM TAP NUMBER | CAM TAP VALVE STATION LOCATION (ELEV/COLUMN/ROW) | AREAS SAMPLED |
|----------------------------|--|--|
| Radwaste Bldg. 01 | RW 702'/F.7/122 | <ul style="list-style-type: none"> a) Spent Resin Tank Vent b) Demin.Valve Aisle 725' Elev. c) Radwaste Bldg. Demin. Cubicle d) Waste Demin. Regen. Area 720' Elev. e) Radwaste Bldg. Tunnel 725' Elev. |
| 02 | RW 702'/H/124.9 | <ul style="list-style-type: none"> a) Unit 1 Off-Gas Refrig. Charcoal Vault Ceiling Space 720' Elev. b) Unit 1 Charcoal Absorber Vault c) Unit 1 Off-gas Refrig. Skid Room 702' Elev. d) Unit 1 After Filter Room 702' Elev. e) Cement Silo Cubicle |
| 03 | RW 702'/H/129.7 | <ul style="list-style-type: none"> a) Evap. Cond. Drain Tank Cubicle 720' Elev. b) Evap. Cond. Drain Tank Pump Cubicle 720' Elev. c) Evap. Cond. Drain Valve Aisle d) Reboiler Area |
| 04 | RW 702'/H.9/124.9 | <ul style="list-style-type: none"> a) Spent Resin Tank Cubicle b) Spent Resin Decant/Sludge Pump Cubicle |
| 05 | RW 702'/H.9/127 | <ul style="list-style-type: none"> a) Radwaste Bldg. Equip. Drain Tank Cubicle b) Radwaste Bldg. Equip. Drain Pump Cubicle c) Radwaste Bldg. Equip. Drain Tank Vent |
| 06 | RW 702'/H.9-J.8/129.7 | <ul style="list-style-type: none"> a) East Phase Separator Tank/Pump Cubicle b) West Phase Separator Tank/Pump Cubicle c) URC Tank Cubicle d) URC Receiving Tank Vent e) URC Storage Tank Vent f) URC Collector Tank Vent g) Phase Separator Tanks Vent |

CPS/USAR

TABLE 12.3-6
SAMPLE TAPS FOR USE WITH PORTABLE
CONTINUOUS AIRBORNE RADIOACTIVITY MONITORS (Continued)

| PORTABLE CAM TAP NUMBER | CAM TAP VALVE STATION LOCATION (ELEV/COLUMN/ROW) | AREAS SAMPLED |
|----------------------------|--|---|
| Radwaste Bldg. 07 | RW 702'/N/126.1-127 | <ul style="list-style-type: none"> a) Chem. Waste Collector/Process Tank/Pump Cubicle North b) Chem. Waste Collector/Process Tank/Pump Cubicle South c) Chem. Waste Collector/Process Tanks Vent d) Chem. Waste Valve Aisle 720' Elev. |
| 08 | RW 702'/N.8/128.7 | <ul style="list-style-type: none"> a) Floor Drain Evap. Feed Tank Cubicle East b) Floor Drain Evap. Feed Tank Cubicle West c) Floor Drain Evap. Feed Pump Cubicle d) West Floor Drain Surge/Collector Tanks Cubicle e) West Floor Drain Surge/Collector Pump Cubicle f) West Floor Drain Surge/Collector Tanks Vent g) Floor Drain Evap. Feed Tanks Vent h) Floor Drain Valve Aisle |
| 09 | RW 702'/N/129.7-131 | <ul style="list-style-type: none"> a) Waste Surge/Collector Tank Cubicle South b) Waste Surge/Collector Tank Cubicle North c) Waste Surge/Collector Pumps Cubicle d) Waste Surge/Collector Tanks Vent e) Radwaste Bldg. Equip. Drain/Floor Drain/Chem. Waste Sump Vents |
| 10 | RW 702'/N-N.8/131 | <ul style="list-style-type: none"> a) East Floor Drain Surge/Collector Tank Cubicle b) East Floor Drain Surge/Collector Pump Cubicle c) East Floor Drain Surge/Collector Tanks Vent d) Floor Drain Valve Aisle e) Radwaste Bldg. Floor Drain Tank Cubicle |

CPS/USAR

TABLE 12.3-6
SAMPLE TAPS FOR USE WITH PORTABLE
CONTINUOUS AIRBORNE RADIOACTIVITY MONITORS (Continued)

| PORTABLE CAM TAP NUMBER | CAM TAP VALVE STATION LOCATION (ELEV/COLUMN/ROW) | AREAS SAMPLED |
|----------------------------|--|---|
| Radwaste Bldg. | | f) Radwaste Bldg. Floor Drain Pump Cubicle g) Radwaste Bldg. Floor Drain Tank Vent h) Laundry Drain Filter Room i) Laundry Sample Tank Room j) Laundry Sample Tank Vent k) Laundry Drain Collector Tank Room l) Laundry Drain Collector Pump Room m) Laundry Drain Collector Tank Vent n) Laundry R.O. & Package Room |
| 11 | RW 762'/E-F/122-124 | a) High Level Drain Storage b) Low Level Drain Storage c) Baler Room d) Truck Aisle |
| 12 | RW 762'/E-F/124 | a) North Waste Mixing Tank Cubicle b) South Waste Mixing Tank Cubicle c) Waste Mixing Tanks Vent d) Fill Port Stations e) Process Mixing Pump Cubicle f) Sodium Silicate Tank Cubicle |
| 13 | RW 762'/J.9-J.8/122 | a) Concentrated Waste Tanks Cubicle b) Concentrated Waste Pumps Cubicle c) Concentrated Waste Tanks Vents d) Air Compressor Area |
| 14 | RW 762'/L.2-M.7/124 | a) Floor Drain/Chem. Waste Evap. Monitor Tank Cubicle North b) Floor Drain/Chem. Waste Evap. Monitor Tanks Vent c) Chem. Waste Condensor/Subcooler Cubicle d) Chem. Waste Separator/Evap. Cubicle e) Chem. Waste Evap. Monitor Tank South f) West Floor Drain Condensor/Subcooler Cubicle |

CPS/USAR

TABLE 12.3-6
SAMPLE TAPS FOR USE WITH PORTABLE
CONTINUOUS AIRBORNE RADIOACTIVITY MONITORS (Continued)

| PORTABLE CAM TAP NUMBER | CAM TAP VALVE STATION LOCATION (ELEV/COLUMN/ROW) | AREAS SAMPLED |
|----------------------------|--|---|
| | | g) East Floor Drain Condensor/Subcooler Cubicle |
| | | h) West Floor Drain Separator/Evap. Cubicle |
| | | i) East Floor Drain Separator/Evap. Cubicle |
| | | j) Excess Water Tank Vent |
| 15 | RW 737'/N-P/124 | a) F/P Filter Demin. Cubicle (4) b) Waste Filter Demin. Cubicle (3) c) Demin. Filter Cubicle d) Demin. Filter Valve Aisle 725' Elev. e) Gen. Area 725' Elev. f) Radwaste Bldg. Pipe Tunnel 720' Elev. |
| 16 | RW 762'/N.8/127 | a) Floor Drain Evap. Monitor Tank Cubicle South b) Waste Sample Tanks Cubicle 762' Elev. c) Waste Sample Tanks Vent |
| 17 | RW 737'/R/128.7 | a) Equip. Decon. Exh. Air Filter 737' Elev. b) Equip. Decon. Room 737' Elev. c) Machine Shop 737' Elev. |
| 18 | RW 737'/N.4/132.4 | a) Machine Shop 737' Elev. b) Personnel Decon/Change Facility c) Personnel Decon./Exh. Air Filter Package 737' Elev. |
| 19 | RW 762'/R/124.9 | a) Mechanical Vacuum Pump |
| Control Bldg. | | |
| 26 | CB 702'/AA/125 | a) 'A' Drywell Purge Cubicle 702' Elev. b) 'B' Drywell Purge Cubicle 702' Elev. c) 'C' Drywell Purge Cubicle 702' Elev. d) H2 Recombiner Area 702' Elev. e) Gen. Floor Area 702' Elev. |
| 27 | CB 702'/AC-AD/124-125 | a) Drywell Purge Units A,B,&C |

CPS/USAR

TABLE 12.3-6
SAMPLE TAPS FOR USE WITH PORTABLE
CONTINUOUS AIRBORNE RADIOACTIVITY MONITORS (Continued)

| PORTABLE CAM TAP NUMBER | CAM TAP VALVE STATION LOCATION (ELEV/COLUMN/ROW) | AREAS SAMPLED |
|----------------------------|--|---|
| 28 | CB 719'/AA/125 | a) Gen. Floor Area 719' Elev. b) SGTS Rooms 719' Elev. |
| 29 | CB 719'/AA/129 | a) Radwaste Bldg. Exh. Fans/Filters Package |
| 30 | CB 762'/Y/128 | a) Dryers Exhaust |
| 31 | CB 762'/Y/128 | a) Radchem Lab Hoods (4) b) High Level Area Hoods (2) c) Cold Lab Hoods (4) |
| 32 | CB 737'/S-T/132-133 | a) Change Room 737' Elev. b) Hot Laundry Hoods (2) c) Contaminated Clothing Draw Receiving Room |
| Fuel Bldg. | | |
| 33 | CB 737'/Y/135 | a) Bioassay Lab and Hoods |
| 34 | CB 737'/AC/129-130 | a) Suction of SGTS Units from Drywell Purge Units A,B,&C |
| 35 | CB 737'/AC/130-132 | a) Suction of SGTS Units from Drywell Purge Units A,B,&C |
| 41 | FB 712'/AK-AL/106.5 | a) Gen. Floor Area 712' Elev. b) Transfer Tube Drain Pump c) Fuel Pool Cooling Pump 'A' d) Fuel Pool Cooling Pump 'B' |
| 42 | FB 737'/AH/114-116 | a) Spent Fuel Storage Pool b) Fuel Cask Storage Pool c) Fuel Transfer Pool |
| 43 | FB 737'/AH/121 | a) Gen. Floor Area 712' Elev. b) Floor Drain Tank Cubicle c) Floor Drain Pump Cubicle d) Equip. Drain Tank Cubicle e) Equip. Drain Pump Cubicle f) Storage Vault g) Floor Drain Tank Vent |

CPS/USAR

TABLE 12.3-6
SAMPLE TAPS FOR USE WITH PORTABLE
CONTINUOUS AIRBORNE RADIOACTIVITY MONITORS (Continued)

| PORTABLE CAM TAP NUMBER | CAM TAP VALVE STATION LOCATION (ELEV/COLUMN/ROW) | AREAS SAMPLED |
|----------------------------|--|---|
| 44 | FB 737'/AL-AM/112.1-116 | a) Fuel Transfer Pool b) Change Area 737' Elev. c) Fuel Pool H/X 'A' Cubicle d) Fuel Pool H/X 'B' Cubicle e) Gen. Area 737' Elev. |
| Fuel/Aux Bldg. | | |
| 45 | FB 737'/AH.AK 121-124 | a) Spent Fuel Storage Pool b) Main Steam Tunnel c) RCIC Pump Room d) HPCS Pump Room e) RHR Pump Rooms A,B,&C f) RHR H/X Rooms A&B g) LPCS Pump Room |
| 46 | FB 737'/AH/121-124 | a) RWCU Pump Rooms A,B,&C b) Radwaste Pipe Tunnel 750' Elev. |
| Containment | | |
| 53 | CT 828'/AC/114 | a) Main Steam Pipe Tunnel b) East Gen. Area Sample Panel 1PL-425 750' Elev. |
| 54 | CT 828'/AC/117 | a) Reg./Non Reg. H/X Cubicle 'B' b) RWCU Valve Room 'B' 789' Elev. |
| 55 | CT 828'/AF/109.5 | a) Refueling Pool |
| 56 | CT 828'/AE/107 | a) Reg./Non Reg. H/X Cubicle 'A' b) RWCU Valve Room Above Holding Pump 814' Elev. c) Filter/Demin Holding Pump Cubicle d) Filter/Demin Vessel Cubicle 'IA' e) Filter/Demin Vessel Cubicle '1B' f) RWCU Valve Room 'A' 789' Elev. |
| 57 | CT 828'/AE/107 | a) RWCU F/O Backwash Receiving Tank Cubicle b) RWCU Backwash Receiving Pump Cubicle c) Pipe Cubicle 789' Elev. d) Containment Floor Drain Sump Vent |

CPS/USAR

TABLE 12.3-6
SAMPLE TAPS FOR USE WITH PORTABLE
CONTINUOUS AIRBORNE RADIOACTIVITY MONITORS (Continued)

| PORTABLE CAM TAP NUMBER | CAM TAP VALVE STATION LOCATION (ELEV/COLUMN/ROW) | AREAS SAMPLED |
|----------------------------|--|--|
| Turbine Bldg. | | |
| 62 | TB 712'/L/104 | a) Condensate Pump Room 712' Elev. b) Toilet 712' Elev. c) Condensate Polishers Sump 712' Elev. d) Condensate Resin Room 712' Elev. e) Condensate Polishers A,B,C, & D 712' Elev. |
| 63 | TB 712'/M/104 | a) Condensate Polishers E,F,G,H,&J 712' Elev. |
| 64 | TB 712'/P/115 | a) Gen. Area 712' Elev. b) Equip. Drain Pumps Cubicle 712' Elev. c) Equip. Drain Tanks Cubicle 712' Elev. d) Floor Drain Pumps Cubicle 712' Elev. e) Floor Drain Tanks Cubicle 712' Elev. |
| 65 | TB 762'/F-G/118.5 | a) Cond. Cavity 762' Elev. b) Toilet 762' Elev. c) Motor Drive Rx Feed Pump 762' Elev. |
| 66 | TB 781'/N/102 | a) Gland Steam Evap. 751' Elev. b) Steam Jet Air Ejec. South 781' Elev. c) Steam Jet Air Ejec. North 781' Elev. d) Gland Steam Cond. South 781' Elev. e) Gland Steam Cond. North 781' Elev. f) Regenerator 781' Elev. g) Desic. Dryer South 781' Elev. h) Desic. Dryer North 781' Elev. |
| 67 | TB 762'/S/114 | a) Steam Tunnel 755' Elev. |
| 68 | | a) Gland Seal System |

12.4 DOSE ASSESSMENT

Dose assessment is an important part of determining and projecting that the plant design and proposed methods of operation assures that occupational radiation exposures will be as low as reasonably achievable. Dose assessment depends upon estimates of occupancy, dose rates in various occupied areas, number of personnel involved in reactor operations and surveillance, routine maintenance, waste processing, refueling, in-service inspection, and special maintenance.

In assessing the collective occupational dose at CPS, the architect-engineer and/or Illinois Power Company evaluated each potentially significant dose-causing activity. Specific items such as design, shielding, plant layout, traffic patterns, expected maintenance, and radioactivity sources were evaluated. The goal was to reduce the exposure associated with each phase of plant operation and maintenance to the minimum level consistent with practical considerations for accomplishing each task. To achieve this goal, the plant design includes numerous significant design improvements to reduce occupational exposures.

Dose assessment is categorized into dose within the station, dose at the restricted area and site boundaries and dose to construction personnel working on the site. Dose assessment for each category is covered in the following subsections.

12.4.1 Dose Within the Station

People working at the station will be exposed to direct radiation from contained sources of radioactivity, and to small amounts of airborne sources which arise from equipment leakage or safety-relief valve blowdown.

The dose assessment and design improvements to reduce the annual dose are based upon data from other operating BWR's. Such data is available from Reference 1, and is summarized in Tables 12.4-1 and 12.4-2.

12.4.1.1 Dose Rate Criteria

Five radiation zones are defined from the design considerations and are described in Subsection 12.3.1.1. Radiation sources used in establishing these zones are given in Subsection 12.2.1 and form the basis of shielding design. Reference 2 provides radiation sources in reactor water and steam for use in estimating "expected" releases through the effluent streams. A comparison of these "expected" sources with the design-basis sources indicates that in general the "expected" sources are smaller than the design-basis sources by a factor of 3 to 20. Hence, for the purpose of annual dose assessment, the expected dose rate criteria for Zones A, B, C, and D have been assumed to be a factor of 3 lower than the design basis criteria. Portions of Zone E areas where access may be required are assumed for dose assessment to have dose rates < 100 mrem/hr, except for some local spots with higher dose rates. Thus, the expected dose rate criteria used in dose assessment are as follows:

CPS/USAR

| Zone | Expected Dose Rate, mrem/hr |
|------|-----------------------------|
| A | 0.17 |
| B | 0.83 |
| C | 6.70 |
| D | 33.00 |
| E | 100.00 |

(Note: A Zone E dose rate of 200 mrem/hr will be used for time spent by inservice inspection personnel working on or near reactor coolant system components.)

Airborne radioactivity concentrations in different accessible areas of the station are given in Table 12.2-13. In general, the airborne radioactivity concentrations are below the Derived Air Concentrations (DACs) given in 10 CFR 20.

12.4.1.2 Dose From Contained Sources

Annual man-rem estimates of dose from contained sources during the performance of reactor operations and surveillance, routine maintenance, waste processing, refueling, inservice inspection, and special maintenance, are given in Table 12.4-3. These dose estimates are calculated from the dose rate criteria discussed above and the best estimates of occupancy requirements in different zones, which are listed in the table. The occupancy estimates are based upon data from the operating stations and reflect improvements made at CPS in the design, radiation monitoring and radiation protection program.

The occupational personnel dose from contained sources is estimated to be 650.5 man-rem/yr/unit, or 0.94 man-rem/MW-yr with a 70% capacity factor. A breakdown of the dose by work functions is provided in Table 12.4-4.

12.4.1.3 Dose From Airborne Radioactivity Sources

Airborne radioactivity is produced by leakage of radioactive materials and from safety-relief valve blowdown.

12.4.1.3.1 Dose From Leakage Sources

Airborne radioactivity produced by equipment leakage is handled by the station ventilation system, as discussed in Subsection 12.3.3. The station ventilation system is designed to maintain air flow patterns so as to prevent the spread of contamination to accessible areas, and to maintain the airborne radioactivity concentrations in the accessible areas below DACs. Therefore, occupancy in areas with potential for any significant exposure to airborne radioactivity is small. Estimates of occupancy in such areas, dose rates derived from airborne radioactivity information of Table 12.2-13, and annual estimated doses to thyroid, lung, and whole body are given in Table 12.4-5. Doses have been calculated using the methodology of Reference 3.

12.4.1.3.2 Dose from SRV Blowdown Sources

Safety/relief valve (SRV) blowdown gives rise to significant amount of airborne radioactivity in the containment for a short period of time after a blowdown event. Effective measures are

CPS/USAR

incorporated in the CPS design to minimize the potential dose to any of the workers who may happen to be in the containment at the time of blowdown initiation, and to those who will enter the containment after the event is over. These measures include the suppression pool cleanup system to remove iodines, which might otherwise become airborne. Administratively, the workers will be instructed to exit through the refueling floor hatch, where the air is expected to remain relatively clean during the egress period. Only the workers occupying the TIP drives area can be expected to exit through the lower hatch, as it is located on the same floor as the TIP drives.

The estimate of dose to workers as a function of time after the blowdown event and the location in the containment is reported in Reference 6. The dose analysis reported in Reference 6 is applicable to the General Electric Company's standard plant design. The results of this analysis have been used in estimating the doses for the CPS because of the similarity of design.

The blowdown event considered in the analysis is the power isolation event, in which the reactor pressure is controlled by the cyclic lifting of the SRV's in the first 30 minutes. The discharge of the low set SRV, which is expected to cycle longer than others, is located under the main steam tunnel, such that it is removed from areas of significant occupancy. The radioactive source terms are based upon the design basis sources for the normal operation as reported in Section 12.2 (and Table 11.1-3), and the equilibrium core inventory with a 95 percentile fuel release. The iodine carryover factor of 2% is used. The pool retention factors used are based upon the partition coefficients of 2×10^{-4} for inorganic iodines, 0.5 for the methyl iodine and 20.0 for krypton. The distribution of airborne sources in the containment is calculated based upon the normal ventilation. Plateout of the airborne sources is neglected.

The representative occupancy locations in the containment are the CRD hydraulic control units area, the refueling floor and the TIP drives area. Egress times for workers occupying each of the areas are estimated based upon the CPS design. The operator egress time for the TIP drives area is expected to be much smaller than 4 minutes, but the latter is assumed to obtain an upper bound dose estimate. The exit times and the estimates of operator doses during egress from different locations in the containment are provided in Table 12.4-6.

12.4.1.4 Design Improvements

Occupational dose reports from operating stations were used for guidance in planning the design improvements. Since maintenance contributes the majority of the man-rem dose, design improvements were introduced to reduce the dose due to maintenance. Some of these improvements consist of installation of spare equipment and the installation of or provisions for shield walls between redundant equipment and between the valves, pumps and tanks belonging to the same systems. Design features such as these are discussed in detail in Section 12.3.

To minimize the airborne radioactivity and thus the dose in the containment following blowdown, cleanup of the suppression pool is provided.

12.4.1.4.1 Modifications Implemented to Reduce Doses

Changes resulting from dose assessment or ALARA reviews are as follows:

- a. CRD scram discharge volume header. The low velocity flushing lines and associated valving were removed and replaced by Hydrolyze connection installed on existing blind flanges in each SDV header. This was installed as a source term reduction modification.

CPS/USAR

- b. Dryer-separator transfer. Incorporated a remote crane operating station.
- c. Fuel Shuffle - Drywell Access - Area Radiation Monitors are placed in the drywell with the sole purpose of providing personnel warning in the event of a dropped fuel bundle during fuel shuffle activities in the RPV/RPV refueling pool.
- d. Radioactive waste storage facilities. Incorporated quick opening access covers on tanks, adequate shield walls, and a station painting and coating code for ease of decontamination.
- e. TIP system. Addressed radiological concerns into operating procedures, and performed an engineering evaluation of the design for manual changeover for storing TIP's in the suppression pool.

12.4.1.4.2 Engineering Techniques for Reducing Occupational Radiation Exposure

Several engineering techniques identified in Reference 4 are already incorporated into CPS design as follows:

- a. A 50% reduction in exposure was realized by designing the CPS evaporators as multi-skid units fabricated from improved material, and by shielding them individually. The anticipated exposure reduction is estimated at 6 man-rem per year.
- b. The major source of personnel exposure for the solid radwaste management system has been associated with the handling of the waste containers during and after they have been filled with spent resins or evaporator bottoms. The CPS design incorporates remote handling, filling, smear and radiation surveys, and loading. The anticipated exposure reduction is estimated at approximately 6 man-rem per year.
- c. Recirculation pump modifications will result in reduced occupational exposure by installation of a clean seal injection system water supply to purge the pump seals, which should result in a 50% reduction in pump seal maintenance. The anticipated exposure reduction is estimated at approximately 12 man-rem per year. Also, a permanent work platform in the vicinity of the pump seals, provided for ease of maintenance, should result in a 10% reduction in the total job time, or a minimum of about 2 man-rem per year.
- d. Safety/relief valve maintenance exposure was reduced by installing a permanent hoisting system on the drywell to aid in the removal and installation of SRV's. The anticipated exposure reduction is estimated at approximately 2 man-rem per year based upon an approximate 25% reduction in transportation time of valves within the drywell.
- e. Main steam isolation valve maintenance exposure was reduced by installing a monorail hoisting system. The exposures received are due largely to the amount of time spent on MSIV maintenance. The anticipated exposure reduction is estimated at approximately 5 man-rem per year based upon an approximate 10% reduction in maintenance repair time.

12.4.1.4.3 Mark III Containment and Innovations for Reducing Occupational Radiation Exposure

Several innovations unique to the Mark III containment are incorporated into CPS design as follows:

- a. The refueling platform incorporates the latest state-of-the-art electrical and mechanical improvements. Principal features include 1) improved structural strength for accuracy in movement from one position to another, 2) use of digital readout devices for platform position determination with greater accuracy and repeatability, and 3) use of a hoisting system for the fuel grapple which is easily controlled. The estimated exposure reduction of 2 man-rem per year is based on approximately a 20% reduction in time spent on the refueling platform.
- b. Reduction of mechanical problems associated with previous designs, remote cable cutting, and disposal techniques have been adapted to the Mark III TIP system design resulting in an estimated exposure reduction of approximately 2 man-rem per year.
- c. A multi-stud tensioner developed for the Mark III accommodates eight studs and includes rapid attachment features. The exposure reduction estimate of approximately 11 man-rem per refueling is based on approximately a 10% reduction in the total tensioning and detensioning time per stud.
- d. A new handling tool has been developed for the Mark III which provides a semi-remote means of removing and replacing a CRD. This air-operated machine is capable of raising and lowering the CRD, torquing the bolts, and transferring the CRD outside the vessel pedestal area. This represents both a significant reduction in crew size and a time savings. The estimated exposure reduction is approximately 10 manrem per year.

12.4.2 Annual Dose at the Restricted Area Boundary

The restricted area boundary is defined in Subsection 2.1.1.3. The estimates of annual doses at the boundary are given in Table 12.4-7. The major sources that contribute significantly to the dose at this boundary are given in the following subsections.

12.4.2.1 Dose from Skyshine

As discussed in Subsection 12.3.1.3.4, the skyshine from the radioactivity in the high-pressure and low pressure turbines, the intercept valves and the associated piping located on the main floor of the turbine building could contribute to the dose at the restricted area boundary. The source inventory in these pieces of equipment is listed in Table 12.2-7. The maximum skyshine dose will be experienced on the southwest side of the boundary and is listed in Table 12.4-7.

12.4.2.2 Dose from Cycled Condensate Storage Tank

The design-basis radiation sources in the cycled condensate storage tank is listed in Table 12.2-8, and the estimated annual dose at the restricted area boundary from this tank is listed in Table 12.4-7.

12.4.2.3 Dose from Gaseous Effluents

The expected radiation sources in the gaseous effluents are listed in Table 11.3-8, and the estimated annual dose at the restricted area boundary from these sources is listed in Table 12.4-7.

12.4.3 Annual Dose at the Site Boundary

The site boundary is defined and discussed in Subsection 2.1.1.3. The major contributors to the dose at this boundary are the same as those given in the previous section. Estimated annual doses are listed in Table 12.4-8.

12.4.4 Compliance with Regulatory Guide 8.19

Since insufficient data is available to provide the occupational dose assessment in accordance with the guidance in Regulatory Guide 8.19, the following comparative method is used. The dose assessment in Table 12.4-3 was derived from the average number of personnel, average length of time to perform each particular function and average dose rate. The occupational dose assessment process is then completed by multiplying the assumed occupancy times the dose rate for the area. Due to variations in operational modes and unknowns associated with equipment maintenance requirements, it was not possible to definitely specify occupancy times in each given area of the plant. Prior plant experience provided useful information on the numbers of personnel needed for jobs, the duration of different jobs, and the frequency of the jobs. Reference 4 provided a job or task approach for estimating annualized man-rem reductions in which each of the tasks was modeled to show man-rem, manhours, and manpower requirements similar to those typically observed at operating stations. The actual man-rem received will depend upon operating experience and maintenance and repair problems encountered. The average man-rem exposure basis for the AIF study (Reference 4) was 625 man-rem/BWR unit. The Table 12.4-1 average for 20 BWR's was 828.6 man-rem/unit. The CPS dose assessment total of 650.5 man-rem is a realistic estimate based upon the radiation protection design features described in Section 12.3, the radiation protection program outlined in Section 12.5, and the ALARA program described in Section 12.1. The dose reductions that may be expected to result from this evaluation process are the principal objective of the dose assessment. The bases for the dose assessment of each category are covered in the following subsections.

12.4.4.1 Reactor Operations and Surveillance

Reactor operations consists primarily of remote operation of equipment from the main control room and periodic roving tours to visually check equipment and areas for any abnormalities. Surveillance consists of regular checks on instrumentation and emergency equipment to ensure proper operation and reliability.

The dose assessment was based on the expected dose rates, typical time periods for operation and surveillance, and 2080 hours per individual. Reference 6 provided the assumed containment operator occupancy during normal operation which was derived from GE experience with previous plants, with consideration given to the equipment found in the Mark III Containment. The values given on Table 4-7, Containment Occupancy Normal Operation, of Reference 6 were considered the maximum expected yearly occupancy during normal operation.

CPS/USAR

12.4.4.2 Routine Maintenance

The dose assessment for routine maintenance was based upon the major tasks being performed at operating BWR's on a routine basis. The major tasks evaluated were control rod drive removal and maintenance, recirculation pump maintenance, MSIV maintenance, safety/relief valve maintenance, snubber inspection/maintenance, RWCU pump maintenance, and TIP repairs.

Any improvements in design or operating procedures incorporated into CPS which were not utilized at other BWR's were included in the dose assessment. These improvements resulted in a major reduction in exposures for certain maintenance tasks. Reference 6 provided useful assumed containment occupancy during normal operation for maintenance personnel involved with RWCU, CRD, refueling equipment, sumps, containment cooling, TIP, I&C panels, ECCS, and process equipment. Exposures were calculated based on 2080 hours per individual.

12.4.4.3 Waste Processing

Waste processing includes operations such as solid waste packaging and transfer, filter replacement and packaging, demineralizer regeneration, and liquid waste processing. Since radwaste operations will be provided round the clock by shift crews with at least one operator in the radwaste operations center (ROC) and one rover, the following assumptions were incorporated:

- a. Zone A - most of the time spent in corridors and at a desk (ROC).
- b. Zones B and C - twice per shift check of equipment.
- c. Zone D - once per shift check of equipment.
- d. Zone E - once per shift check of 1/3 of equipment, thereby checking all equipment each day.

12.4.4.4 Refueling

Refueling of the reactor consists of two distinct major phases: 1) removal replacement of the reactor head and the transferring of the dryer and separator; and 2) fuel handling operations.

The majority of the exposure associated with removal and reassembly of components can be attributed to the close proximity of personnel to the highly activated vessel internals. The total exposure resulting from the actual fuel movement is due to the large number of man-hours needed to complete that task. Exposures were calculated based on 160 hours per individual to accomplish refueling.

12.4.4.5 Inservice Inspection

Inservice inspection required by the ASME Boiler and Pressure Vessel Code requires a detailed examination of Class 1, 2, and 3 pressure boundary components in accordance with a detailed schedule. The examination will be accomplished utilizing teams of examiners typically composed of two inspectors and one assistant. There will be a supervisor overseeing operations of the teams.

CPS/USAR

The dose assessment was based upon typical manpower requirements at various BWR's. Additional data was utilized from Reference 8. Exposures were calculated based on 320 hours per individual to accomplish inservice inspection.

12.4.4.6 Special Maintenance

Special maintenance is generally of a non-recurring nature and is not readily predictable. It includes retrofit of systems, design changes, and unexpected replacement or repair of equipment and components. Since CPS is of a new BWR design, many of the problems which have occurred at operating BWR's should not occur at this facility.

For purpose of estimating a dose assessment for special maintenance (see Table 12.4-2), an average percentage of the total annual 1977 operating exposure from the 20 BWR's listed in Table 12.4-1 was utilized. This average percentage of the annual operating exposure due to special maintenance was 45.7%.

12.4.5 References

1. NUREG-0482, "Occupational Radiation Exposure At Light Water Cooled Power Reactors," Annual Report, 1977.
2. ANS 18.1-ANSI N237-1976, "Source Term Specification."
3. NRC Regulatory Guide 1.109, "Calculation of Annual Doses to Man From Routine Releases of Reactor Effluents for the Purpose of Evaluating Compliance With 10 CFR 50, Appendix I," March 1976.
4. Atomic Industrial Forum, "Engineering Techniques for Reducing Radiation Exposure," Draft III.
5. Electric Power Research Institute, "Evaluation of Operational Techniques that can Reduce Radiation Fields in LWRs During Maintenance," EPRI NP-332, Project 820-1, Final Report, March 1979.
6. General Electric, "Mark III Containment Dose Reduction Study," 22A5718, December 5, 1977.
7. Southwest Research Institute, "Access and Design Considerations for Inservice Inspection - Boiling Water Reactor Systems."
8. General Electric, "Inservice Inspection," 22A2756, Rev. 2.

CPS/USAR

TABLE 12.4-1
DATA FROM OPERATING BWR's FOR 1977*

| PLANT SITE | TOTAL MAN-REM | MAN-REM/MW - YR |
|-------------------|---------------|-----------------|
| Cooper | 197 | 0.37 |
| Vermont Yankee | 258 | 0.61 |
| Duane Arnold | 299 | 0.85 |
| Millstone 1 | 392 | 0.68 |
| Hatch 1 | 465 | 1.04 |
| Browns Ferry 1, 2 | 863 | 0.65 |
| Monticello | 1000 | 2.35 |
| Quad Cities 1, 2 | 1031 | 1.06 |
| Fitzpatrick | 1080 | 2.35 |
| Brunswick | 1119 | 3.84 |
| Nine Mile Point | 1383 | 3.98 |
| Oyster Creek | 1614 | 4.18 |
| Dresden 1, 2, 3 | 1693 | 1.49 |
| Peach Bottom 2, 3 | 2036 | 1.93 |
| Pilgrim | 3142 | 9.92 |

* Taken from Reference 1. BWR's with capacity < 100 Mwe have not been listed.

CPS/USAR

TABLE 12.4-2
DATA FROM OPERATING BWR's FOR 1977
PERCENTAGES OF DOSES BY WORK FUNCTION

| WORK FUNCTION | DOSE, MAN-REM | PERCENTAGE |
|-------------------------------------|---------------|------------|
| Reactor operations and surveillance | 1435 | 9.5 |
| Routine maintenance | 4523 | 30.0 |
| Waste processing | 1092 | 7.2 |
| Refueling | 526 | 3.5 |
| Inservice inspection | 614 | 4.1 |
| Special maintenance | 6888 | 45.7 |
| TOTAL | 15,078 | 100.00 |

CPS/USAR

TABLE 12.4-3
ESTIMATES OF OCCUPATIONAL RADIATION
DOSE FROM CONTAINED SOURCES

| <u>FUNCTION</u> | <u>RADIATION ZONE</u> | <u>DOSE RATE (Mrem/hr)</u> | <u>NO. OF PERSONS</u> | <u>OCCUPANCY %</u> | <u>DOSE (man-rem/yr-unit)</u> |
|-------------------------------------|-----------------------|----------------------------|-----------------------|--------------------|-------------------------------|
| Reactor operations and surveillance | A | 0.17 | 60 | 83.4 | 17.7 |
| | B | 0.83 | 60 | 14.0 | 14.5 |
| | C | 6.70 | 60 | 2.0 | 16.7 |
| | D | 33.00 | 60 | 0.5 | 20.6 |
| | E | 100.00 | 60 | 0.1 | 12.5 |
| | | | | | Total |
| Routine maintenance | A | 0.17 | 72 | 87.3 | 22.2 |
| | B | 0.83 | 72 | 7.6 | 9.4 |
| | C | 6.70 | 72 | 3.3 | 33.1 |
| | D | 33.00 | 72 | 1.5 | 74.1 |
| | E | 100.00 | 72 | 0.3 | 44.9 |
| | | | | | Total |
| Waste processing | A | 0.17 | 5/5 | 94/100 | 3.43 |
| | B | 0.83 | 5 | 2.0 | 0.13 |
| | C | 6.70 | 5 | 2.0 | 1.41 |
| | D | 33.00 | 5 | 1.2 | 4.13 |
| | E | 100.00 | 5 | 0.8 | 8.50 |
| | | | | | Total |

CPS/USAR

TABLE 12.4-3 (Cont'd)

| FUNCTION | RADIATION ZONE | DOSE RATE (Mrem/hr) | NO. OF PERSONS | OCCUPANCY % | DOSE (man-rem/yr-unit) |
|-------------------------|-------------------------|---------------------|-------------------|-------------|------------------------|
| Refueling | A | 0.17 | 41 | 30.0 | 0.3 |
| | B | 0.83 | 41 | 40.0 | 2.2 |
| | C | 6.70 | 41 | 24.0 | 10.6 |
| | D | 33.00 | 41 | 4.0 | 8.7 |
| | E | 100.00 | 41 | 2.0 | 13.1 |
| | | | | Total | 34.9 |
| Inservice inspection | A | 0.17 | 16 | 92.6 | 0.8 |
| | B | 0.83 | 16 | 1.5 | 0.1 |
| | C | 6.70 | 16 | 1.7 | 0.6 |
| | D | 33.00 | 16 | 1.1 | 1.9 |
| | E | 100.00* | 16 | 3.1 | 31.7 |
| | | | | Total | 35.1 |
| Special maintenance | UNKNOWN - Average 45.7% | | From Table 12.4-2 | | 297.3 |
| Total for all functions | | | | | 650.5 |

* See Section 12.5.2

CPS/USAR

TABLE 12.4-4
OCCUPATIONAL RADIATION DOSE BY WORK FUNCTIONS

| FUNCTION | DOSE man-rem/yr/unit | PERCENTAGE OF TOTAL DOSE |
|-------------------------------------|-------------------------|-----------------------------|
| Reactor operations and surveillance | 81.9 | 12.6 |
| Routine maintenance | 183.7 | 28.2 |
| Waste processing | 17.6 | 2.7 |
| Refueling | 34.9 | 5.4 |
| Inservice inspection | 35.1 | 5.4 |
| Special maintenance | 297.3 | 45.7 |
| Total | 650.5 | 100.0 |

CPS/USAR

TABLE 12.4-5
ESTIMATES OF OCCUPATIONAL RADIATION DOSE FROM AIRBORNE RADIOACTIVITY

| LOCATION | DOSE RATE, rem/hr | | | | Occupancy (man-hr/yr) | DOSE (man-rem/yr) | | | |
|--|-------------------|-------|--------|---------------|--------------------------|-------------------|-------|--------|---------------|
| | Thyroid | Lung | b-Skin | Whole Body | | Thyroid | Lung | b-Skin | Whole Body |
| 1. Containment- General Area | 1.4-3 | 5.0-7 | - | - | 33,850 | 4.7+1 | 1.7-2 | - | - |
| 2. Containment - Radiation Areas | 3.9-2 | 3.6-5 | - | - | 400 | 1.6+1 | 1.4-2 | - | - |
| 3. Drywell | 3.8-2 | 1.7-4 | 9.5-3 | 7.5-3 | 400 | 1.5+1 | 6.8-2 | 3.8+0 | 3.0+0 |
| 4. Auxiliary Bldg - Radiation Areas | 4.6-2 | 4.2-5 | - | - | 675 | 3.1+1 | 2.8-2 | - | - |
| 5. Fuel Bldg - Radiation Areas | 3.4-6 | 4.3-7 | - | - | 490 | 1.6-3 | 2.1-4 | - | - |
| 6. Radwaste Bldg - Radiation Areas | 1.2-2 | 2.8-4 | - | - | 1,040 | 1.2+1 | 2.9-1 | - | - |
| 7. Turbine Bldg - Radiation Areas | 2.6-4 | 1.2-6 | 6.8-5 | 5.5-5 | 1,040 | 2.7-1 | 1.2-3 | 7.1-2 | 5.7-2 |
| TOTAL | | | | | | 1.2+2 | 4.2-1 | 3.8+0 | 3.0+0 |

CPS/USAR

TABLE 12.4-6
ESTIMATE OF OCCUPATIONAL RADIATION DOSE
 FROM A SAFETY/RELIEF VALVE BLOWDOWN EVENT

| LOCATION | EGRESS TIME, MIN. | MAXIMUM*** OPERATOR DOSE, MREM | | |
|--|----------------------|--------------------------------|--------|-------------|
| | | THYROID | 8-SKIN | LENS OF EYE |
| TIP Drive Area, El. 737'-0" | 4* | 8.1-1** | 3.9+2 | 1.4+2 |
| CRD Hydraulic Control Unit Area, El. 755'-0" | 2.85 | 7.0-2 | 1.1+0 | 1.7+0 |
| Refueling Floor, El. 828'-3" | 2.25 | 4.6-2 | 1.6-2 | 2.1-1 |

* Conservative value to obtain an upper bound of the radiation dose value.

** 8.1-1 should be read as 8.1×10^{-1} .

*** Based on a 95 percent cumulative probability fuel release.

CPS/USAR

TABLE 12.4-7
ESTIMATED ANNUAL DOSES AT THE RESTRICTED AREA BOUNDARY

| | SOURCE | DOSE (man-rem/yr) |
|----|---------------------------------|-------------------|
| 1. | Skyshine | 6.5-4 |
| 2. | Cycled Condensate Storage Tank. | 5.2-3 |
| 3. | Gaseous Effluents (gamma Dose) | 8.4-5 |
| | TOTAL | 5.9-3 |

Assumptions Used

1. Radiation sources used for items 1 and 2 are given in Section 12.2, and for item 3 are given in Section 11.3.
2. Occupancy at the restricted area boundary is assumed to be 0.5 hrs/wk.

CPS/USAR

TABLE 12.4-8
ESTIMATED ANNUAL DOSES AT THE SITE BOUNDARY

| | SOURCE | DOSE (man-rem/yr) |
|----|---------------------------------|-------------------|
| 1. | Skyshine | 2.4-6 |
| 2. | Cycled Condensate Storage Tank. | 3.1-7 |
| 3. | Gaseous Effluents (gamma dose) | 3.9-6 |
| | TOTAL | 6.6-6 |

Assumptions Used

1. Radiation sources used for items 1 and 2 are given in Section 12.2, and for item 3 are given in Section 11.3.
2. Occupancy at the site boundary is assumed to be 0.5 hrs/wk.

CPS/USAR

Table 12.4-9 has been deleted intentionally.

12.5 RADIATION PROTECTION PROGRAM

12.5.1 Organization

The administrative organization for the Radiological Protection Program is shown in site organization charts. The functions, qualifications, and responsibilities for personnel are in accordance with the guidelines of Regulatory Guide 1.8.

The Radiation Protection Shift Supervisors are responsible for the performance of assigned duties consistent with the Radiological Protection Program during their shift period. The Radiation Protection Shift Supervisors supervise the RP technicians in monitoring the radiological conditions of CPS, handling radioactive materials, and controlling radiation zone work. The Radiation Protection Shift Supervisors have the authority to stop any work in any Radiological Control Area, or order its evacuation, when, in their judgment, the radiological conditions warrant such an action and such actions are consistent with plant safety. Whenever work in progress or station operations require the presence of more than one RP technician, the designated Radiation Protection Manager may require at least one individual qualified as a Radiation Protection Shift Supervisor assigned to each shift to provide radiological controls and advice. This individual shall coordinate radiological control activities, initiate actions to prevent or mitigate radiological problems and keep the Shift Supervisor advised of significant events and problems. The Radiation Protection Shift Supervisors report to the Radiation Protection Manager for all administrative matters and normal technical direction, and implement special technical directions from Health Physics Analysis Group personnel and such special orders and directions as the Shift Supervisor may issue during unusual or emergency situations.

The Radiation Protection Technicians (RP Technicians) are responsible for monitoring the radiological conditions of CPS, handling radioactive material, and controlling radiation zone work. RP Technicians have the authority to stop any work in a Radiological Control Area, or order its evacuation, when, in their judgment, the radiological conditions warrant such an action and such actions are consistent with plant safety. RP Technicians report to the Radiation Protection Shift Supervisor.

Refer to Section 13.1.2.2 for minimum RP shift coverage.

12.5.2 Equipment, Instrumentation, and Facilities

The selection of radiological equipment and instrumentation considers the following:

- a. operational reliability,
- b. instrument response,
- c. frequency and type of calibration,
- d. ease of maintenance,
- e. ease of mobility in the case of portable instruments and equipment,

CPS/USAR

- f. user performance evaluation, and
- g. economic considerations.

The Plant Radiation Protection department maintains sufficient radiological analysis capability. This capability includes Chemistry's gross counting and spectral analysis capability utilizing a number of different technologies. In addition, a facility exists for instrument maintenance, calibration, and storage. Facilities for both these functions are located on El. 737 ft 0 in. elevation of the Control Building.

Respiratory protection equipment is maintained and stored in a facility normally in the unit 2 crossover respirator issue room just off the Radwaste building general access hallway at El. 737 ft 0 in. reserved for this function. Respiratory equipment maintenance and storage meet industry quality standards to assure the readiness of the equipment when used.

Protective clothing storage locations are located for ease of access and to provide assurance of the readiness for immediate use. Protective clothing storage locations are normally located at: (1) El. 737 ft 0 in. Turbine Building; (2) El. 737 ft 0 in Auxiliary Building; and (3) El. 828 ft 0 in. Control Building (outside the entrance to the Containment Building). Secondary locations are utilized as the need dictates.

In addition, CPS has committed to and will comply with the requirements of Regulatory Guide 8.8 (Revision 4) C.4.d.(1) and (2) (Q&R 471.17).

Pertinent information regarding portable and laboratory technical equipment and instrumentation is given in Table 12.5-2. The number of portable radiation detection instruments is listed in Table 12.5-2. The need for spare, operational instruments is satisfied through the availability of emergency kits (Q&R 471.13).

The implementation of station radiological control procedures assures compliance with the applicable provisions of Regulatory Guides 1.33 (for radiological controls program), 4.1, 4.13, 4.15, 7.1, 7.3 (with exceptions), 7.4, 8.1, 8.2 (with exception), 8.4, 8.5, 8.6, 8.7, 8.8 (with exceptions), 8.9, 8.10, 8.12 (with exception), 8.13, 8.15, 8.27 (with exception), 8.28 (with exception), and 8.29. Regulatory Guides 8.3, 8.11, 8.14, 8.18, 8.20, 8.21, 8.22, 8.23, 8.24, 8.25, 8.26, 8.30 and 8.31 do not apply to operations at Clinton Power Station. The CPS position on Regulatory Guide 1.97 is covered in Sections 1.8 and 7.1.2.6.23. The noted exceptions to Regulatory Guide 8.8 involve Section C.2.a and the use of more stringent design and administrative controls for high radiation areas with 1000 mrem/hr or greater (called locked high radiation areas) than for high radiation areas with 100 mrem/hr or greater but less than 1000 mrem/hr. The noted exception to Regulatory Guide 8.12 involves the use of design features and administrative controls to preclude the possibility of accidental criticality rather than using an installed criticality accident alarm system. See Section 1.8 of this SAR for further information on Regulatory Guide applicability and exceptions. The noted exception to Regulatory Guide 8.28 involves the use of self performance checks for determining if electronic dosimetry is properly operating rather than use of a radiation source.

12.5.3 Procedures

Adherence to radiological protection procedures and operating and maintenance procedures containing radiological protection requirements will ensure that personnel radiation exposures

CPS/USAR

are within the limits of 10 CFR 20 and are ALARA. Policy and operational considerations for keeping exposures ALARA are set forth in Subsections 12.1.1 and 12.1.3.

12.5.3.1 Radiation Surveys

Radiation Protection personnel perform surveys of areas where radiation levels are less than 100 mrem/hour at a frequency that may vary from once each shift to once each year depending on the frequency of entries into the area and the probability of radiological conditions changing. Special surveys related to specific operations and maintenance activities are performed prior to, during, and/or after the activity, based on the information required for keeping exposures ALARA. Continuing surveys are made in occupied areas when it is possible that the radiological conditions may change while the area is occupied. The conduct of radiological surveys is described in station procedures.

12.5.3.2 Procedures and Methods Ensuring ALARA

Radiation Safety and ALARA principles are incorporated into procedures which may result in personnel radiation exposure or challenge routine radiation safety. Procedures which fall into this category are reviewed by RP personnel and are denoted as such in the procedure coding. Examples of such considerations are discussed for the following categories.

12.5.3.2.1 Refueling

Prior to reactor head removal the void for collection of gases has been reduced by filling the Reactor Pressure Vessel to just below the RPV flange to reduce the possibility of significant airborne radioactivity. Provision has been made to use the Drywell Purge System to evacuate potentially radioactive gases from the reactor vessel head area prior to removal of the reactor head if warranted. The refueling pool water is filtered and demineralized to remove particulate activity and is then passed through a heat exchanger to cool the water once the RPV has been disassembled and the pool filled.

The HVAC system provides an air sweep of the water surface, to control airborne radioactivity. These procedures minimize the probability of exposure from direct radiation and airborne radioactivity. Strict adherence to approved station procedures for refueling operations and to the radiological considerations addressed in the Radiation Work Permit will assure that exposures to radiation are ALARA.

12.5.3.2.2 Inservice Inspection

Preparation for entry into a radiation area may require review of system drawings, pictures, previous inspection reports, and radiation and contamination survey data. Time necessary for job completion, and thereby personnel exposure, will be minimized by proper advance planning. A Radiation Work Permit will be issued when necessary to cover the details necessary to keep personnel exposures ALARA.

12.5.3.2.3 Radwaste Handling

The handling of high activity radwaste by individuals has been minimized by incorporating the processing of liners inside shielded casks. Strict adherence to approved station procedures assuring the maximizing of remote operations and to the radiological considerations addressed in the Radiation Work Permit will assure that exposure to radiation is ALARA.

CPS/USAR

12.5.3.2.4 Spent Fuel Handling, Loading, and Shipping

Spent fuel handling and loading is performed under at least 8 feet of water. The fuel pool water is filtered and demineralized to reduce activity. Cooling of the pool water and an air sweep of its surface minimize inhalation dose. While moving fuel periodic air samples are analyzed to evaluate airborne activity. In addition, provisions are made to continuously monitor airborne radioactivity. Strict adherence to approved station procedures and to the radiological considerations addressed in the Radiation Work Permit assures the maximizing of remote operations and will assure that exposure to radiation is ALARA.

12.5.3.2.5 Normal Operation

The station is designed so that significant radiation sources are separately shielded or located in cubicles. Most monitoring of equipment in shielded cubicles is performed by remote readout. Where remote readout is not possible, operators will enter cubicles with high radiation levels in accordance with an approved Radiation Work Permit or Radiological Surveillance Permit which assure that exposure to radiation is ALARA.

12.5.3.2.6 Routine Maintenance

Where applicable, instructions will specify portions of radioactive systems and components which are to be isolated, flushed, and/or drained in order to reduce the radiation levels in the maintenance area. Special tools and provision for component removal limit the radiation dose received by reducing the time spent in the radiation area. Preplanning of any maintenance action requires review of procedure, prints, and equipment history. Specific Radiation Work Permits are normally issued for any maintenance performed on systems containing radioactive material or maintenance performed in Radiological Control Areas involving moderate or significant radiological risk.

12.5.3.2.7 Sampling

Routine sampling of radioactive systems is performed inside sample sinks which are ventilated to remove airborne activity which may be released. Procedures specify the appropriate radiological controls to be utilized to preclude the spread of contamination and maintain exposures ALARA.

12.5.3.2.8 Calibration

Calibration of most of the portable gamma-detection instruments is performed inside a shielded calibrator, thus nearly eliminating personnel exposure. High activity portable sources are transported in shielded containers. Where possible, instruments requiring routine calibration are placed outside of high radiation areas and the necessary valves and/or electrical connections are provided so that test signals can be inserted to safely calibrate the instrument in place. Station procedures incorporate steps to utilize any applicable ALARA design considerations. Special notes, cautions and warnings contained in procedures alert personnel to dangerous situations or special conditions.

12.5.3.3 Controlling Access

Radiological Control Areas (RCAs) are posted and postings indicate minimum entry requirements. Radiation Work Permits (RWPs) are normally required for work, or other

CPS/USAR

activities which involve the accumulation of radiation exposure. Work involving moderate or significant radiological risk (as defined in station procedures) normally requires an RWP to be in place to ensure the necessary radiological controls are in place. The RWP will provide a means to authorize those who may enter and provides other pertinent information to ensure the activity is performed in keeping with ALARA. RWP approval is from a Radiation Protection Shift Supervisor or individuals designated by the Radiation Protection Manager. For High Radiation/Locked High Radiation Areas, further access control is afforded in accordance with the Clinton Power Station Technical Specifications, Section 5.7.

Radiological Control Area occupancy restrictions are described in orientation training to ensure that personnel are familiar with these restrictions.

12.5.3.4 Area, Equipment, and Personnel Contamination Control

Area contamination surveys are performed on a frequency based on the likelihood of levels increasing or based on the likelihood of the spread of contamination to non-contaminated areas. Additional surveys may be performed after maintenance activities or after a specific operation which may have increased the contamination levels. Where it is considered impractical to decontaminate an area to general occupancy values, the boundaries of the area are defined and posted and a step-off-pad is used (when feasible) to prevent the spread of contamination.

Tools and equipment used in Contamination or Airborne Radioactivity Areas are monitored and/or bagged prior to being removed from these areas. Monitoring and/or bagging is not required for tools and equipment which remain within these areas. Contamination and/or radiation surveys are performed on tools and equipment prior to release of the item for unrestricted use. Plant procedures state the method and levels to which items must be decontaminated before release and state the method of control for those items which are not released.

Protective clothing, engineering or process controls, respirators, and training are provided to minimize the possibility of external and internal personnel contamination. However, the total effect (e.g., total effective dose equivalent and health risk) is factored into the selection process when prescribing protective requirements. As a result of this total effect evaluation, minor personnel contaminations and/or minor intakes may result. It is the individual's responsibility to frisk (either automated or manual frisking) at a frisking station located in the vicinity of Contamination Areas and to use the provided monitors prior to exiting the Radiological Control Area (RCA) at the egress point located near the Radiation Protection Office or the RCA egress point located near the Mechanical Maintenance area in the southeast corner of the Radwaste Building. Temporary RCA egress points may be established to support plant activities with the approval of the designated Radiation Protection Manager. When contamination is found, radiation protection personnel will direct the decontamination in accordance with station procedures.

12.5.3.5 Training Programs

All personnel assigned to CPS are required to receive radiological control training. The training shall be commensurate with the requirements of the employee's specific job/function. Specific training requirements are outlined in Exelon procedure TQ-AA-118, Nuclear General Employee Training - NGET.

CPS/USAR

12.5.3.6 Personnel Monitoring

Exposure data for those personnel receiving occupational exposure at CPS is maintained on Form NRC-5, "Occupational Radiation Exposure For A Monitoring Period", or the equivalent. Occupational exposures incurred by individuals prior to working at CPS is summarized on Form NRC-4, "Cumulative Occupational Radiation Exposure History", or the equivalent. These records are maintained at the plant. The monitoring results are analyzed and necessary reports are generated to comply with 10 CFR 20. Current exposure status is made available to the individual and supervisory/foreman personnel to assist in keeping individual exposures ALARA.

12.5.3.6.1 Personnel External Exposure

All personnel entering any RCA are required to wear dosimetry prescribed by RP personnel, normally consisting of a dosimeter of legal record (DLR). Activities which require the individual to access an RWP will require a pocket ionization chamber or electronic dosimeter. When personnel who have not completed radiation worker training need to enter an RCA, they will be escorted by a radiation worker. CPS shall use DLRs for external radiation exposure that are processed by a Dosimetry Processor, accredited by the National Institute of Standards and Technology National Voluntary Laboratory Accreditation Program (NVLAP) in Categories I through VIII.

Radiation surveys provide a means of estimating personnel external radiation exposure. Routine and special dose rate surveys are taken to provide detailed information for in-plant exposure evaluation.

12.5.3.6.2 Personnel Internal Exposure

Bioassays are performed as appropriate for personnel entering any Radiological Control Area. Station procedures describe the criteria for which personnel entering any RCA receive baseline, termination, and/or diagnostic bioassays.

12.5.3.7 Evaluation and Control of Potential Airborne Radioactivity

The Continuous Airborne Radioactivity Monitors (CAM's) provide information concerning airborne radioactivity concentrations as described in Subsection 12.3.4. Routine portable air samples and special samples give additional data to Radiation Protection personnel for evaluation of the plant situation and application of appropriate protective measures. Control is normally accomplished by the application of engineering controls, including process, containment, and ventilation equipment. When it is impracticable to apply process or other engineering controls to limit concentrations of airborne radioactivity, other precautionary procedures, such as increased surveillance, limitation of working times, or respiratory protective equipment, are used to maintain exposures ALARA. The selection of the proper respiratory device for radiological applications is the responsibility of Radiation Protection personnel. All inspection and testing of respiratory protection equipment is performed by trained individuals. No attempts are made to repair or make adjustments to a respiratory protective device beyond the manufacturer's recommendations.

CPS/USAR

12.5.3.8 Radioactive Source Control

Various types and quantities of radioactive sources are employed to calibrate the process radiation monitors and the portable and laboratory radiation detectors. Specific radioactive sources that are integral to process radiation monitors that consist of exempt quantities of byproduct isotopes do not require special handling, or use procedures for radiation protection purposes. Recognized methods for the safe handling of radioactive materials are implemented to maintain potential external and internal doses ALARA.

All radioactive sources procured under the CPS Operating License will be controlled according to NRC regulations. At a minimum these controls include:

- a. Monitoring all packages containing radioactive material prior to shipment and upon receipt for external dose rates and removable contamination.
- b. Leak testing of sealed sources shall be conducted consistent with the Operational Requirements Manual.
- c. Conducting periodic inventories of all non-exempt quantity sources.
- d. Storing in a controlled storage area all sources that are not installed in an instrument or other piece of equipment.

Radioactive sources are subject to additional controls commensurate with the radiological risk/hazard. Individuals handling non-exempt radioactive sources have received training which familiarizes them with the radiological restrictions and limitations associated with the use of the sources.

CPS/USAR

TABLE 12.5-1

DELETED

CPS/USAR

TABLE 12.5-2
PORTABLE AND LABORATORY TECHNICAL EQUIPMENT AND INSTRUMENTATION

| NAME | TYPE OF DETECTOR | ACCURACY | RANGE | QUANTITY | REMARKS |
|--|---|-------------------------------|----------------------------|----------|--|
| Alpha Survey Meter | Scintillation | ±10% of full scale being read | 0-5 x 10 ⁵ cpm | 2 | Eberline PRM-6 with AC-3 probe or equivalent |
| Neutron Survey Meter (Fast-Slow/ Rem Counter) | Cd-Loaded Polyethylene Sphere with BF ₃ Tube | ±20% directional response | 0 mrem/hr-5 rem/hr | 2 | Eberline PNR-4 with NRD probe or equivalent |
| Count Rate Meter (Frisker) | Geiger-Mueller | ±10% of full scale | 0-50,000 cpm 0-500,000 cpm | 23 | Eberline RM-14/RM-20 with HP260 or HP210 or equivalent |
| Intermediate Range Survey Meter, Beta-Gamma | Geiger-Mueller | ±10% of full scale being read | 0-2000 mR/hr | 4 | Eberline E520 or equivalent |
| Intermediate Range Dose Rate Meter, Beta-Gamma | Ionization Chamber | ±10% of full scale being read | 0-5000 mR/hr | 11 | Eberline RO-2 or equivalent |
| High Range Survey Meter, Beta-Gamma | Geiger-Mueller with extendable probe | ±10% of full scale being read | 0.1 mR/hr - 1000 R/hr | 3 | Telectector or equivalent |
| High Range Dose Rate Meter, Beta-Gamma | Ionization Chamber | ±10% of full scale being read | 0-50 R/hr | 3 | Eberline RO-2A or equivalent |

CPS/USAR

TABLE 12.5-2
PORTABLE AND LABORATORY TECHNICAL EQUIPMENT AND INSTRUMENTATION (Continued)

| NAME | TYPE OF DETECTOR | ACCURACY | RANGE | QUANTITY | REMARKS |
|--|---|--------------------|--|----------|--|
| Portable Counting Equipment, Beta-Gamma | Geiger-Mueller | ±10% of full scale | scaler 0-10 ⁵ cpm | 2 | Eberline BC-4 or equivalent |
| Portable Counting Equipment, Alpha | Scintillation | ±10% of full scale | scaler 0-10 ⁵ cpm | 1 | Eberline SAC-4 or equivalent |
| Portable Area Radiation Monitor | Geiger-Mueller | ±20% of indication | 0.1 to 2.2x10 ³ mR/hr | 5 | Stored in a convenient location for use throughout the Station |
| Portable Continuous Air Monitor (three primary channels) | Particulate (B scintillation) | ±20% of indication | 8.1x10 ⁻¹² to 1.2x10 ⁻⁷ µCi/cc | 4 | |
| | Iodine – 131 (SCA-Nal) with noble gas subt. | ±20% of indication | 9.43x10 ⁻¹² to 3.71x10 ⁻⁷ µCi/cc | | |
| | Noble gas (B scintillation) | ±20% of indication | 8.4x10 ⁻⁷ to 3.7x10 ⁻² µCi/cc | | |
| Portal Monitor | Solid Scintillant | | | 4 | |
| Air Sampler - Regulated | Not applicable | Not applicable | 1-3 CFM | 9 | Radeco H809V-1 or equivalent |
| Air Sampler - Low Volume | Not applicable | Not applicable | 1-2 LPM | 2 | MSA Lapel or equivalent |

CPS/USAR

TABLE 12.5-2
PORTABLE AND LABORATORY TECHNICAL EQUIPMENT AND INSTRUMENTATION (Continued)

| NAME | TYPE OF DETECTOR | ACCURACY | RANGE | QUANTITY | REMARKS |
|----------------------|---|----------|---------------|----------|---------------------------|
| DLR | Thermoluminescent material or optically stimulated luminescence | | | 800 | |
| Electronic Dosimeter | Solid State Silicon | | 0 - 9999 mRem | 200 | MGP DMC-100 or equivalent |

NOTE: Equipment and instrumentation shown in this table may be used throughout the plant and in the local environment.

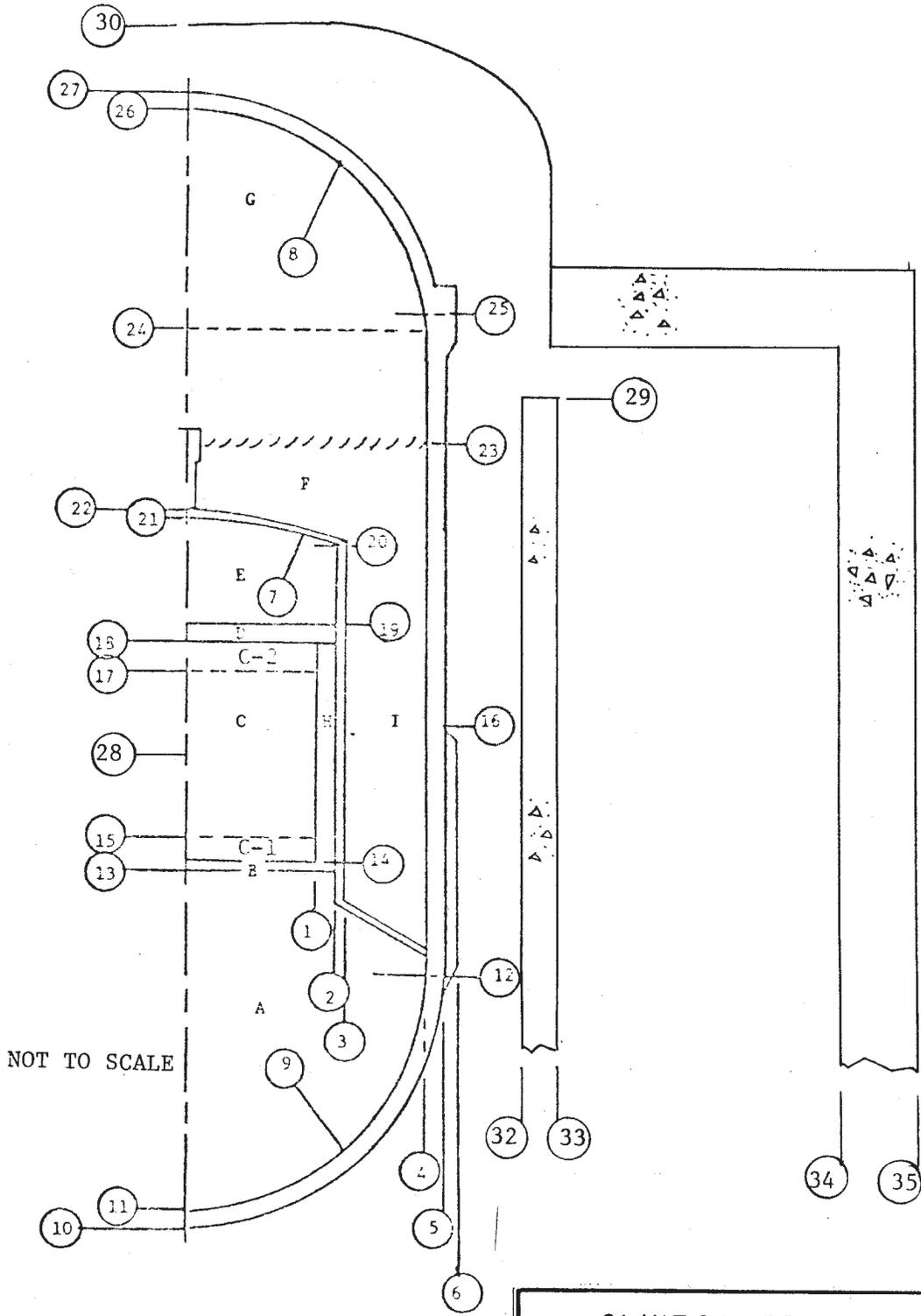

See Table 12.2-1 for dimensions

CLINTON POWER STATION
UPDATED SAFETY ANALYSIS REPORT

FIGURE 12.2-1

BASIC REACTOR AND DRYWELL MODEL

FIGURES 12.3-1 THROUGH 12.3-29
HAVE BEEN DELETED

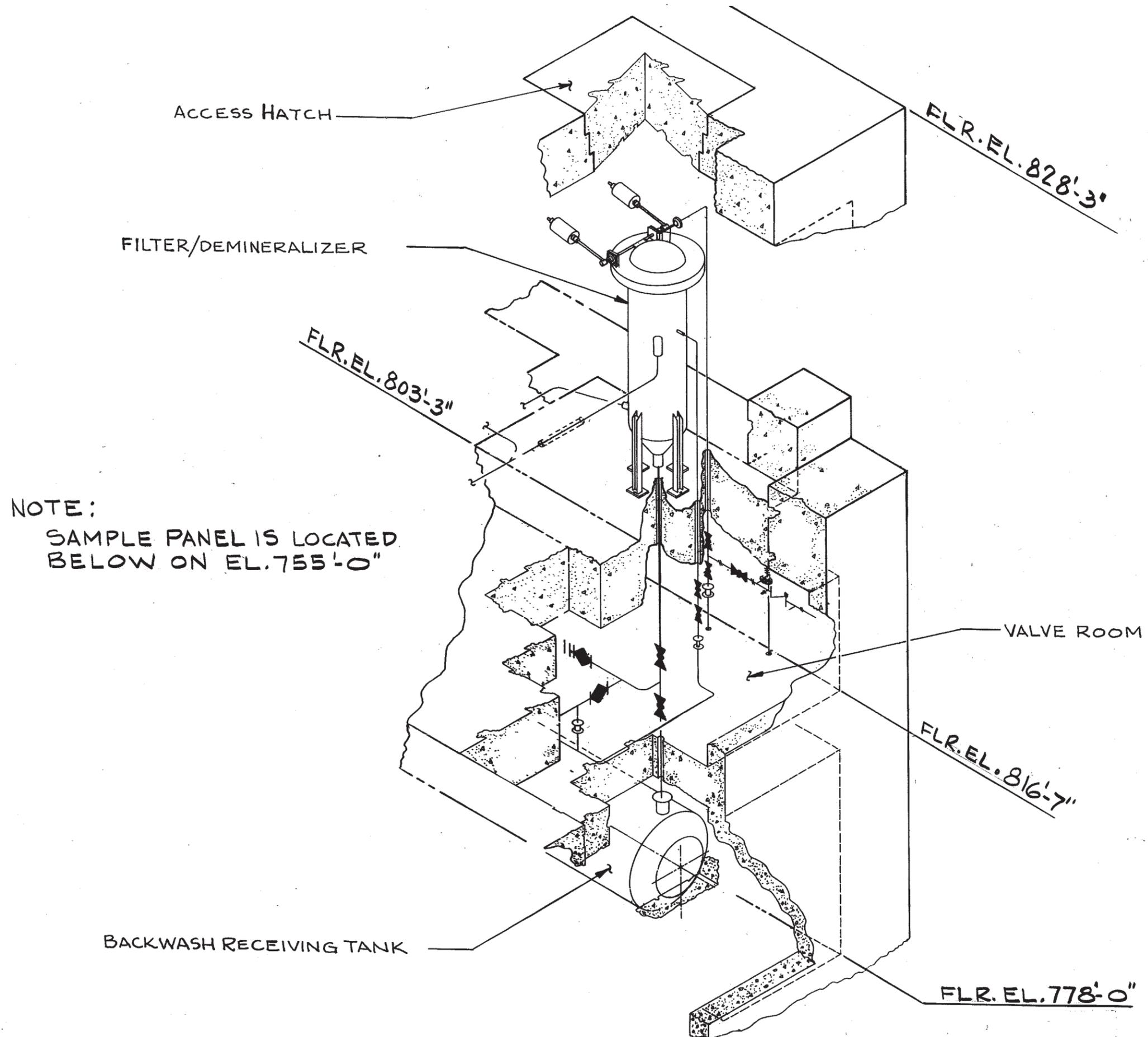

CLINTON POWER STATION
 UPDATED SAFETY ANALYSIS REPORT

FIGURE 12.3-30

ISOMETRIC VIEW OF THE RCU
 FILTER/DEMINERALIZER AND
 ASSOCIATED EQUIPMENT

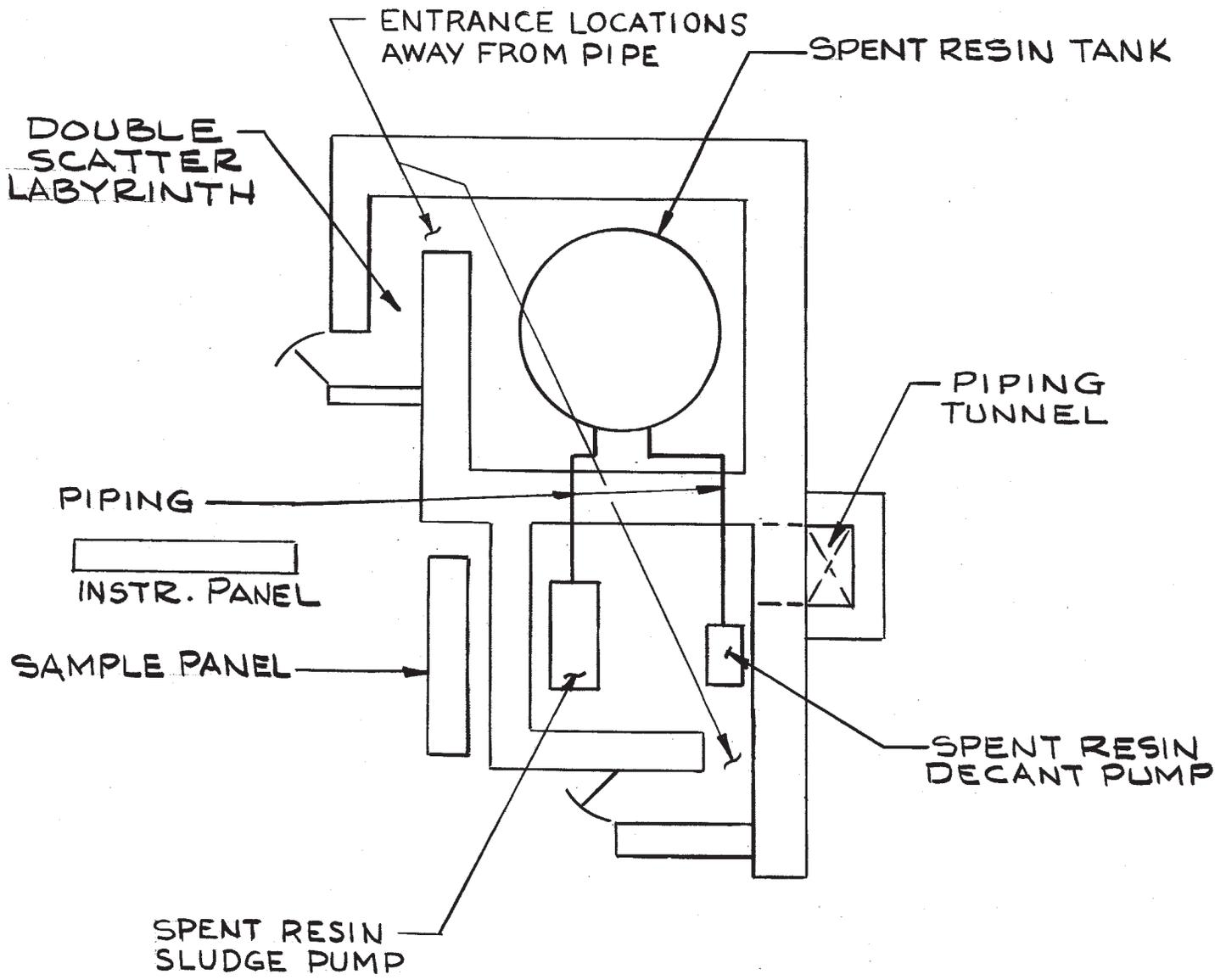

CLINTON POWER STATION
 UPDATED SAFETY ANALYSIS REPORT

FIGURE 12.3-31

SPENT RESIN TANK AND PUMP CUBICLES

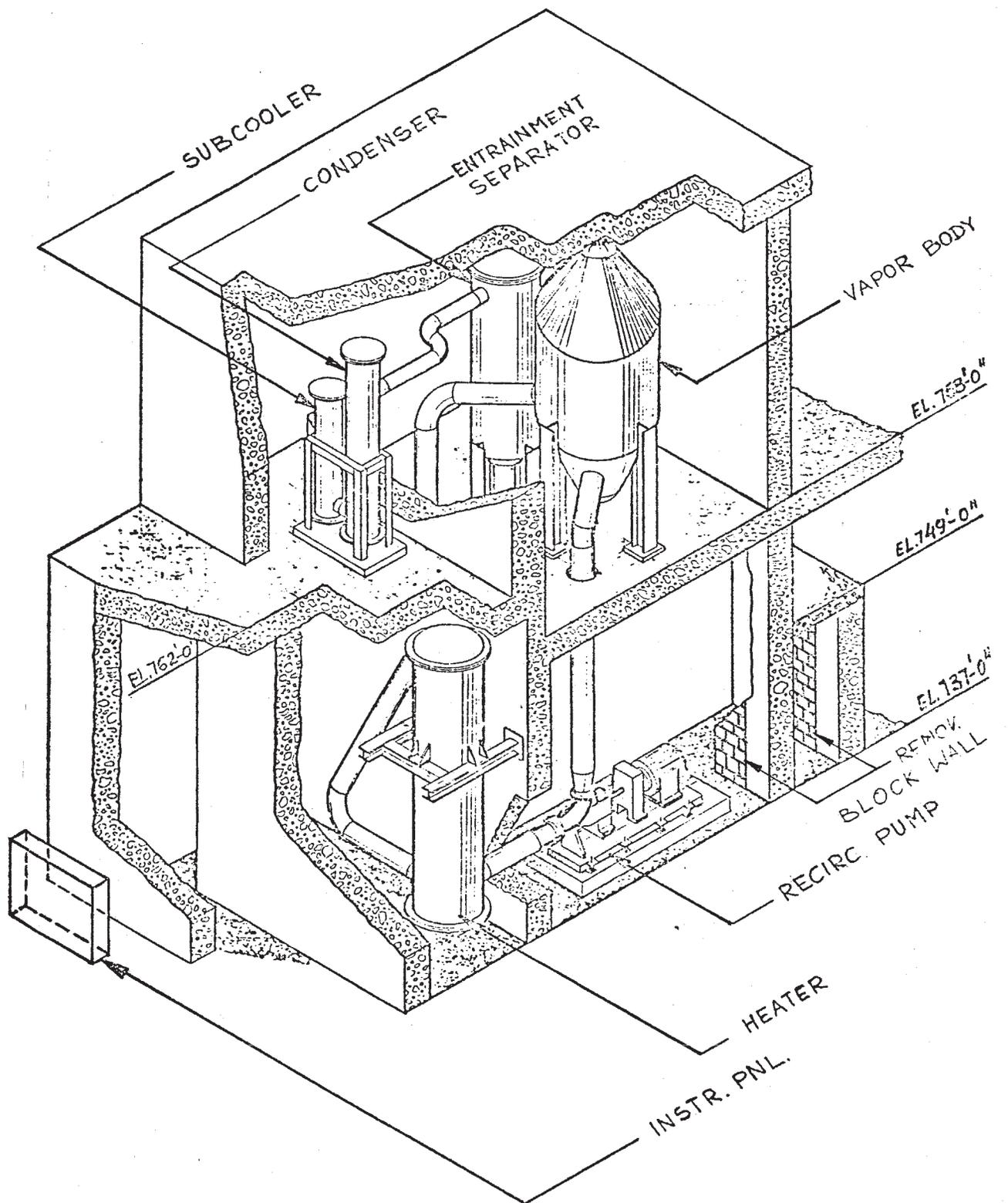

CLINTON POWER STATION
 UPDATED SAFETY ANALYSIS REPORT

FIGURE 12.3-32

ISOMETRIC VIEW OF THE CHEMICAL
 WASTE EVAPORATOR

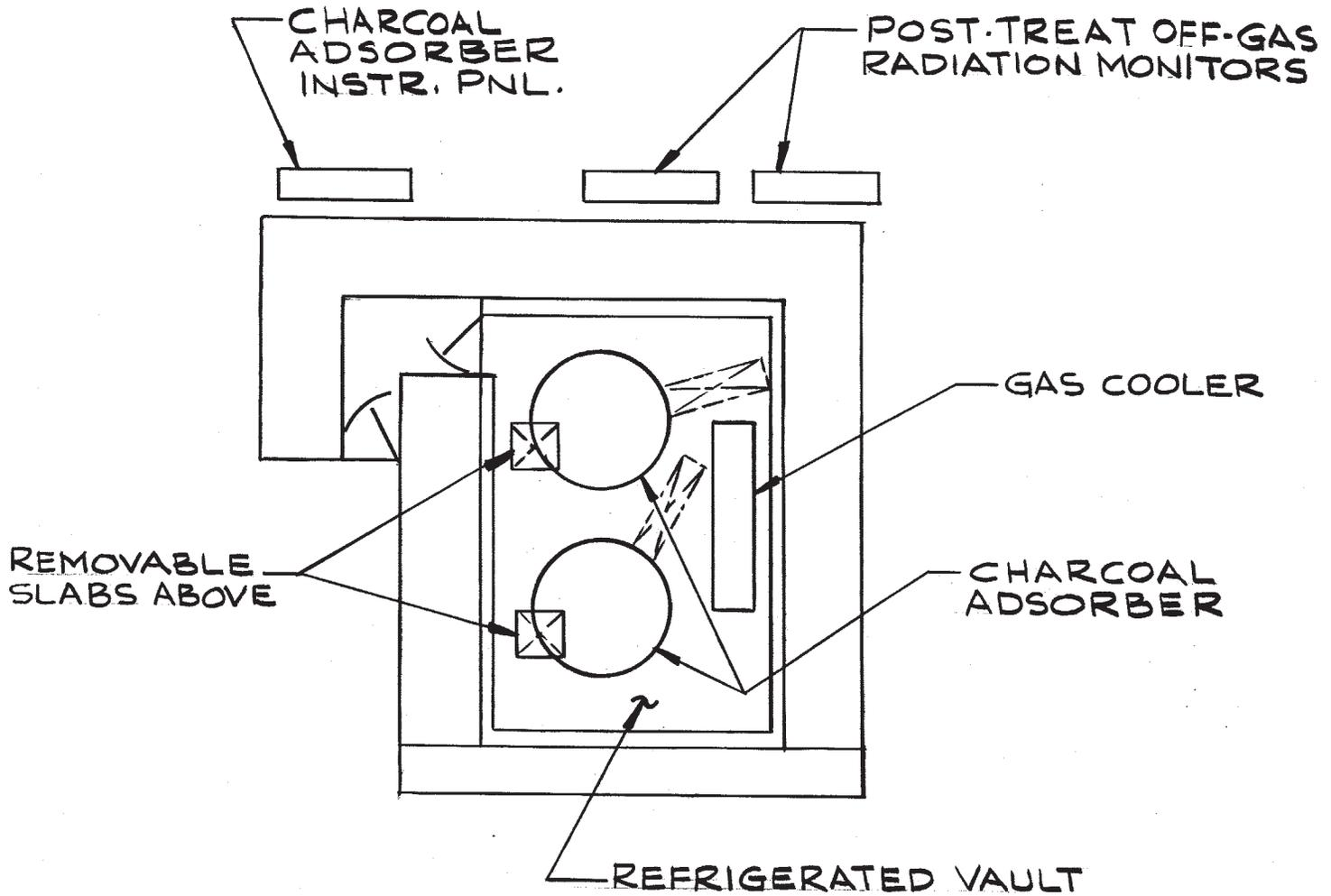

| |
|--|
| <p>CLINTON POWER STATION UPDATED SAFETY ANALYSIS REPORT</p> |
| <p>FIGURE 12.3-33</p> |
| <p>CHARCOAL ADSORBER ROOM</p> |

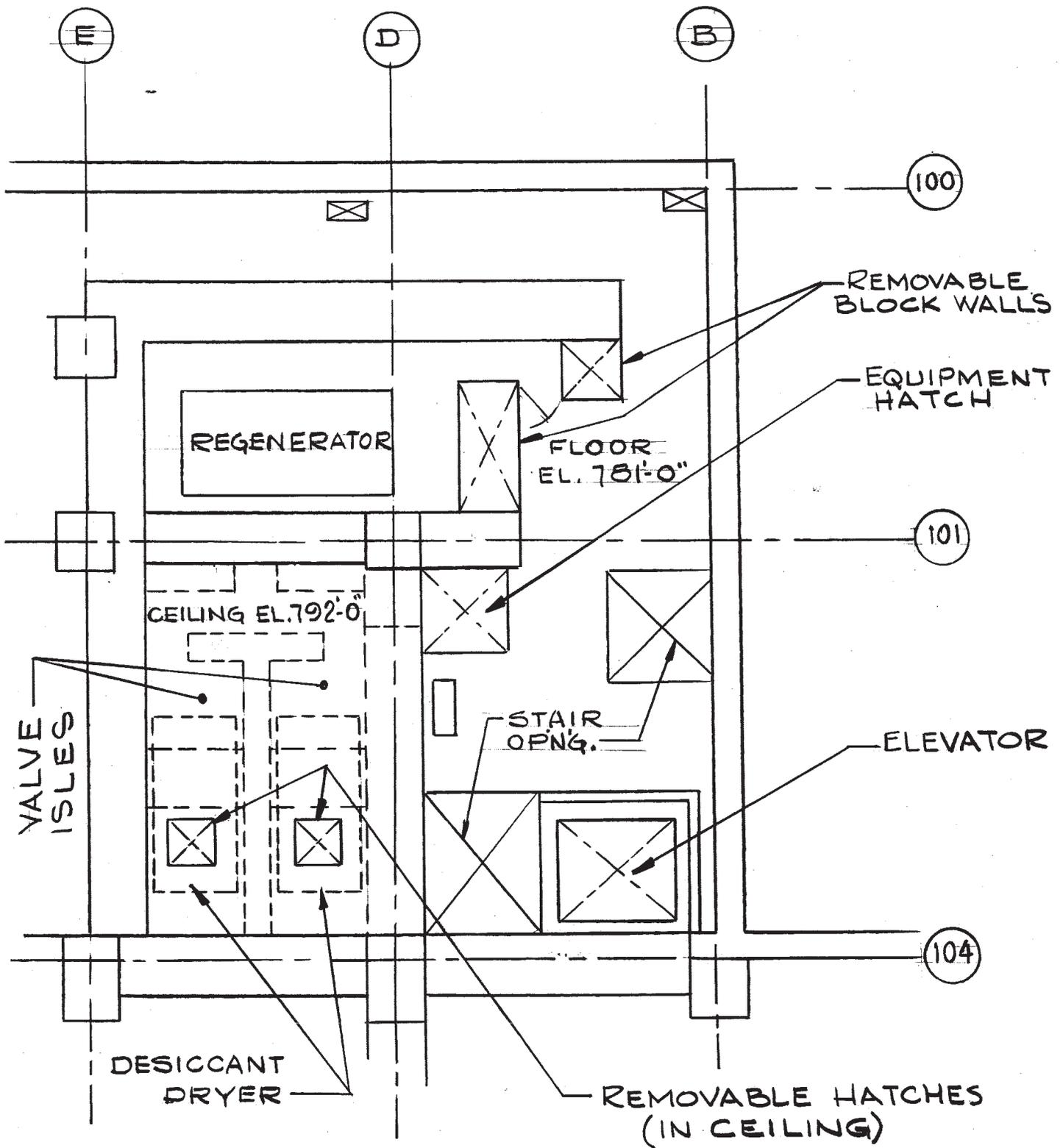

CLINTON POWER STATION
 UPDATED SAFETY ANALYSIS REPORT

FIGURE 12.3-34

DESICCANT DRYER AND REGENERATOR ROOMS

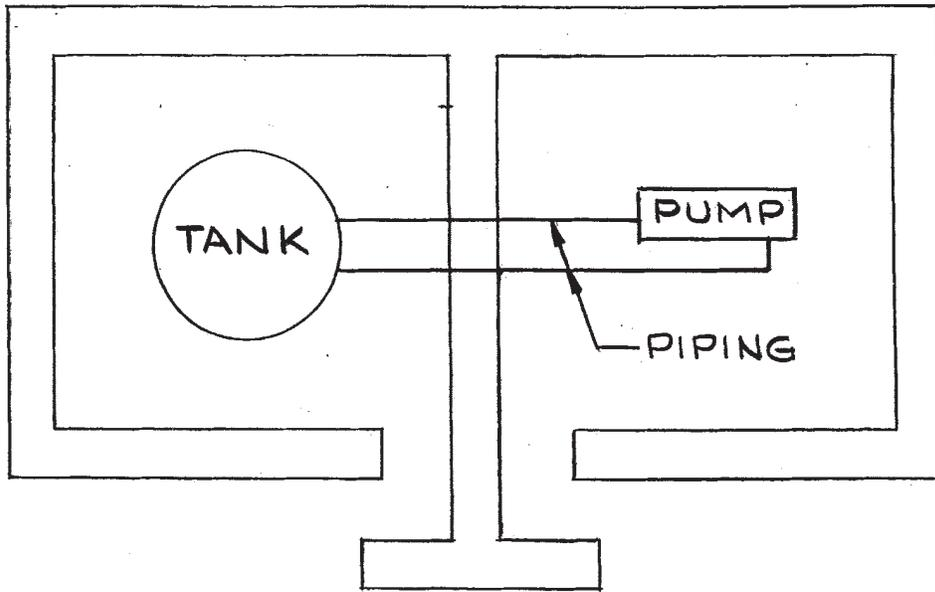

A. UNDESIRABLE ENTRANCE LOCATIONS

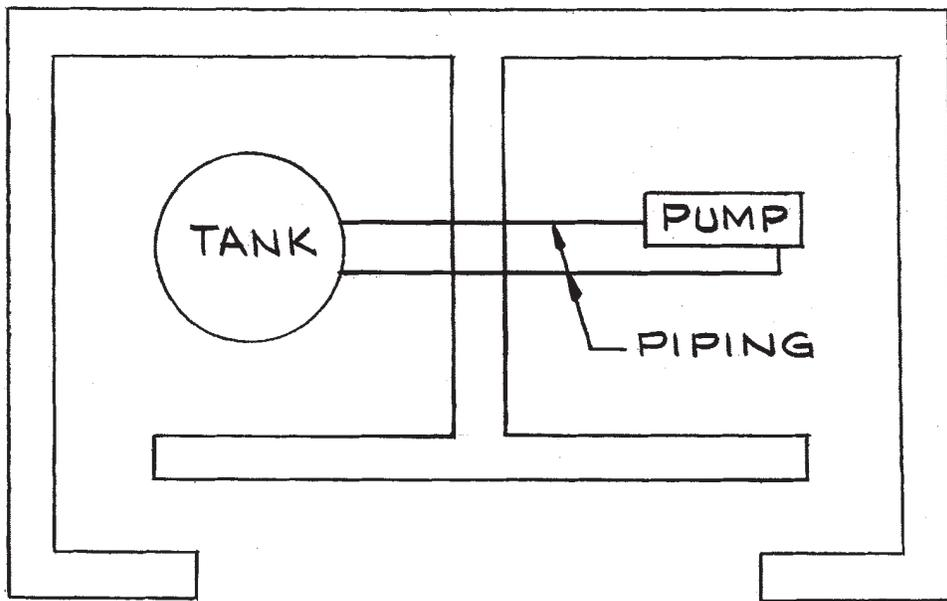

B. DESIRABLE ENTRANCE LOCATIONS

CLINTON POWER STATION
 UPDATED SAFETY ANALYSIS REPORT

FIGURE 12.3-35

DESIRABLE ENTRANCE LOCATIONS

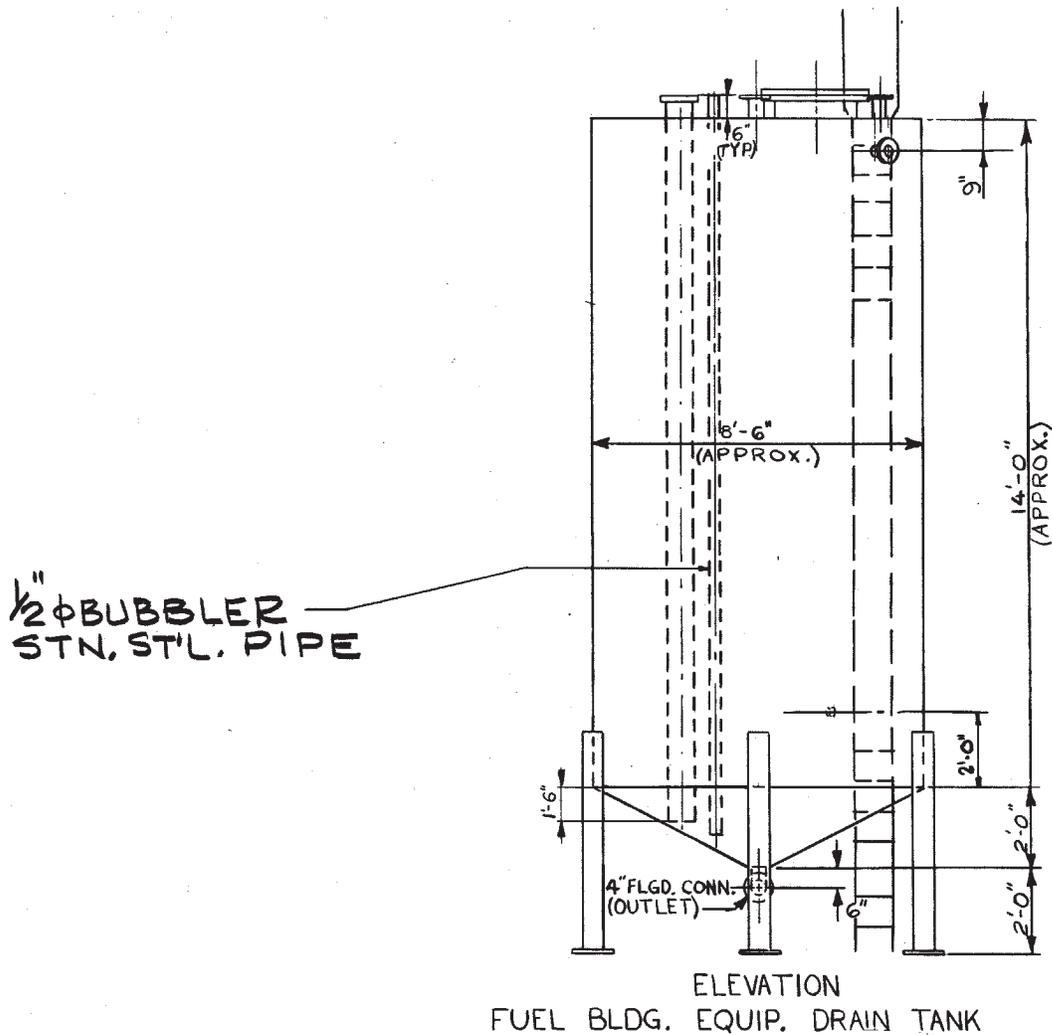

NOTE:
 VERTICAL TANK WITH CONICAL BOTTOM
 MINIMIZES CRUD BUILDUP.

CLINTON POWER STATION
 UPDATED SAFETY ANALYSIS REPORT

FIGURE 12.3-36

TYPICAL DESIGN OF A RADIOACTIVE TANK
 THAT MINIMIZES CRUD POCKETS

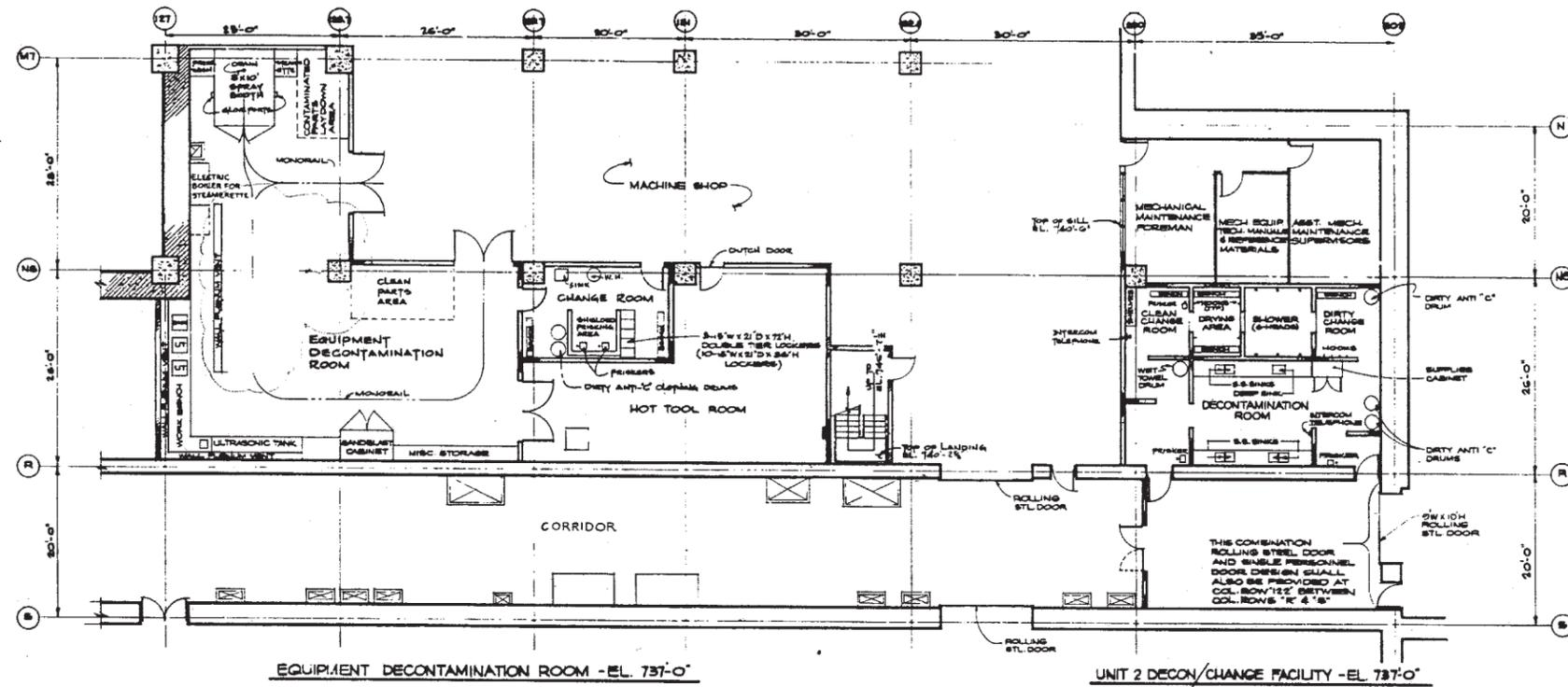

CLINTON POWER STATION
 UPDATED SAFETY ANALYSIS REPORT

FIGURE 12.3-37

LAYOUT OF THE EQUIPMENT
 DECONTAMINATION ROOM AND
 UNIT 2 DECON./CHANGE FACILITY

CPS/USAR

Revision 12
January 2007

Figures 12.3-38 through 12.3-63 have been deleted.

|

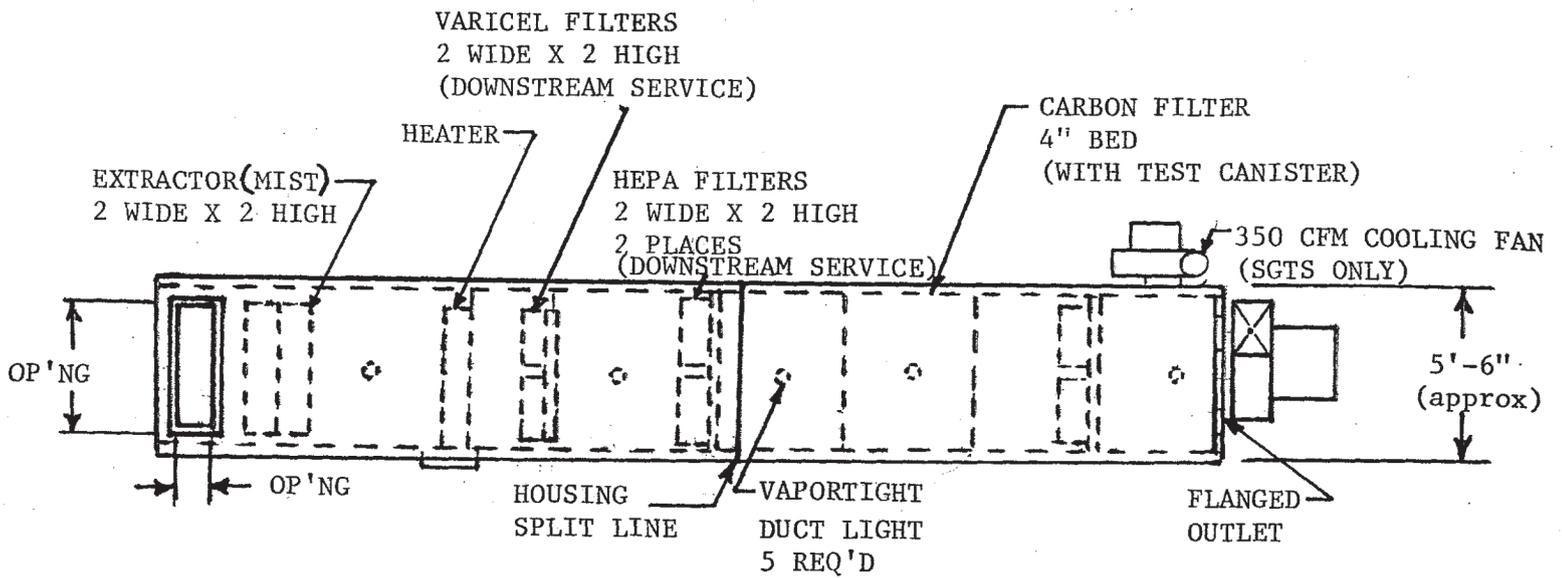

PLAN

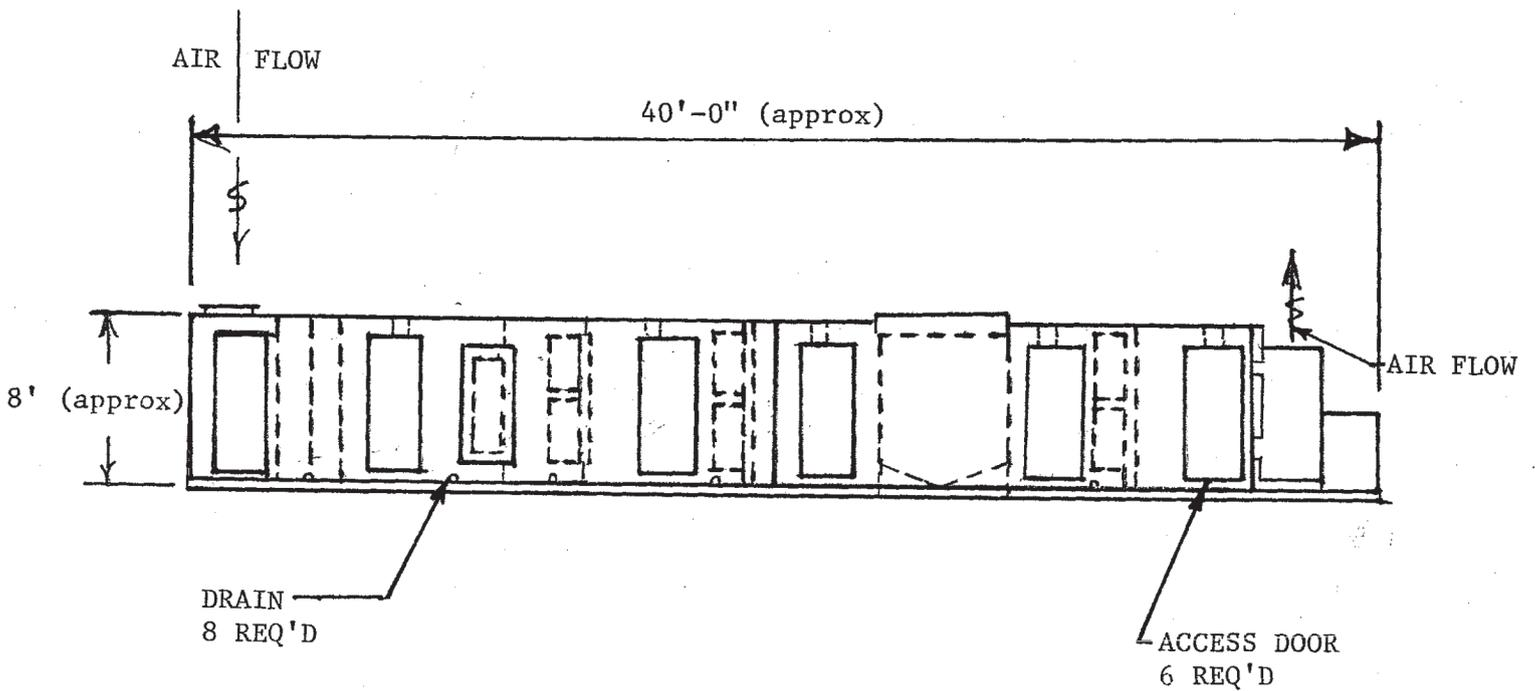

SIDE ELEVATION

| |
|---|
| <p>CLINTON POWER STATION UPDATED SAFETY ANALYSIS REPORT</p> |
| <p>FIGURE 12.3-64</p> |
| <p>TYPICAL FILTER PACKAGE</p> |