

SUPPLEMENT I.1: GENERAL DESCRIPTION OF 24PT1-DSC CANISTER

I.1.0 GENERAL INFORMATION

The HI-STORM UMAX System stores a sealed canister containing spent nuclear fuel in an in-the-ground Vertical Ventilated Module (VVM). The HI-STORM UMAX system including the MPC-37 and MPC-89 canisters is described in the main body of this report. The format of this supplement follows the same format as the main body of the report, based on the content suggested in NRC Regulatory Guide 3.61 and NUREG-1536, with the addition of a material compatibility chapter as suggested by ISG-15.

Supplement I adds the 24PT1-DSC canister to the HI-STORM UMAX system [I.1.2.1]. Only those design features of “UMAX” that are revised or added to incorporate the 24PT1-DSC canister are described in this supplement. This supplement also references to the main body of the FSAR where existing safety analyses are bounding, as applicable.

Since the 24PT1-DSC canister has already been approved by the NRC for storage under Part 72, (and is presently in active use) under Docket No. 72-1029, much of the safety analysis information is incorporated herein by reference to the NUHOMS FSAR [I.1.2.1], as described specifically in each chapter. For clarity, a table in the beginning of each chapter (Table I.1.0.1 below) identifies the information incorporated by reference, the source of the information, a reference to the NRC approval of the information (SER), where in this supplement it is incorporated, and a discussion of the applicability of the previously approved information.

It is noted that the information incorporated herein by reference is based on the docketed, NRC-approved licensing basis. If any change is made to a canister under the original licensing basis under 10 CFR 72.48, such change will need to be evaluated against the HI-STORM UMAX before the canister can be stored in a HI-STORM UMAX system. The material in this supplement is organized to mirror the corresponding material in the main body of the FSAR with the letter I. inserted before each chapter/section/subsection/paragraph number. Thus the numeric sequence I.m.n.p.r indicates that the material belongs to Supplement I, Chapter #m, Section #n, sub-section# p and paragraph # r. (m, n, p and r are numeric values). Thus, the numbering of the material in the supplement is readily distinguished from the main FSAR’s while the content correspondence is maintained.

HOLTEC INTERNATIONAL COPYRIGHTED MATERIAL	
HI-2115090	Proposed Rev. 3.E
I.1-1	

Table I.1.0.1: Material Incorporated by Reference

Information Incorporated by Reference	Source of the Information	NRC Approval of Material Incorporated by Reference	Location in this FSAR where Material is Incorporated	Technical Justification of Applicability to HI-STORM UMAX
Canister Description	Section 1.2.1.1 Reference [I.1.2.1]	SER Advanced NUHOMS Amendment 0, Reference [I.1.2.2]	I.1.2.1.1	The canister is the same as the one described in the FSAR and originally approved in the referenced SER.
HI-TRAC VW design	Section 1.2.1.3 Reference [I.1.2.3]	SER HI-STORM FW Amendment 0, Reference [I.1.2.3]	I.1.2.1.3	The HI-TRAC VW used with the 24PT1-DSC is the same as the one originally approved in the referenced SER. The Cask Handling Apparatus (CHA) is fully evaluated in this supplement.
Criticality Safety	Section 1.2.2.3.1 Reference [I.1.2.1]	SER Advanced NUHOMS Amendment 0, Reference [I.1.2.2]	I.1.2.2.3.1	Criticality is controlled by geometry and neutron absorbing materials in the fuel basket. The basket is made from stainless steel, with a fixed borated neutron absorbing material known as Boral™, which ensures criticality control of the fuel. The canister is maintained in a sealed, dried condition, so the criticality evaluations are unchanged.

HOLTEC INTERNATIONAL COPYRIGHTED MATERIAL	
HI-2115090	Proposed Rev. 3.E
I.1-2	

I.1.1 INTRODUCTION

The HI-STORM UMAX System is described in Section 1.1 in the main body of the FSAR. This supplement only describes the information related to the 24PT1-DSC canister. The 24PT1-DSC canister has previously been qualified for both storage (under 10 CFR Part 72) and transportation (under 10 CFR Part 71). The safety evaluations performed in support of these original approvals remain applicable for the 24PT1-DSC canisters to be stored in the HI-STORM UMAX Storage System. Throughout this appendix, this information from previously reviewed and approved material is incorporated by reference, and is identified in tables at the beginning of each chapter. Safety evaluations have not been re-performed if the previously evaluated and approved conditions bound those for the canister in the HI-STORM UMAX System. New safety evaluations have been performed as described in this appendix, only if the original evaluations are not applicable to the 24PT1-DSC canister in the HI-STORM UMAX System. These evaluations are based on the design basis 24PT1-DSC canister, note that if an individual canister has been modified under the provisions of 10 CFR 72.48, those modifications will also need to be evaluated against this HI-STORM UMAX FSAR before storage of that canister.

The information in this supplement is based on the operational process starting from removing the 24PT1-DSC canister from its current storage module, placing it in a HI-TRAC transfer cask, and moving it to a HI-STORM UMAX VVM storage cavity. This supplement does not describe transportation operations, as that is outside the HI-STORM UMAX Part 72 generic license. Additionally, this appendix only considers canisters that have been loaded, sealed, and dried in accordance with CoC 72-1029, which is a condition for storing the 24PT1-DSC canister in a HI-STORM UMAX.

The 24PT1-DSC canister is designed to store 24 intact, or up to 4 damaged and remainder intact, standard PWR fuel assemblies. The 24PT1-DSC is designed for a maximum heat load as listed in Subsection I.2.1.9. The fuel which may be stored in the 24PT1-DSC canister within the HI-STORM UMAX system is identified in Section I.2.1.

HOLTEC INTERNATIONAL COPYRIGHTED MATERIAL	
HI-2115090	Proposed Rev. 3.E
I.1-3	

I.1.2 GENERAL DESCRIPTION OF THE 24PT1-DSC CANISTER

I.1.2.1 System Characteristics

The HI-STORM UMAX System consists of interchangeable canisters, which maintain the configuration of the fuel and is the confinement boundary between the stored spent nuclear fuel and the environment. The storage VVM is described in Subsection 1.2.2 of the main body of this report and is not repeated herein. In addition, the previously certified transfer cask, HI-TRAC VW, that provides the structural and radiation protection to the canister during its transfer to the storage overpack is also used to effectuate the transfer of the subject canister to the “UMAX” VVM.

I.1.2.1.1 The 24PT1-DSC Canister

The 24PT1-DSC enclosure vessels are cylindrical weldments with a fixed outside diameter. Each canister is an assembly consisting of a fuel basket, a cylindrical shell, a bottom cover plate, and a top cover plate with redundant closures. The canister has 24 SNF storage locations.

The 24PT1-DSC enclosure vessel is a fully welded enclosure, which provides the confinement for the stored fuel and radioactive material. The 24PT1 is equipped with two shield plugs so that occupational doses at the ends are minimized. The canister cover plates and shell are made of stainless steel. The cylindrical shell and the top and bottom cover plate assemblies form the pressure retaining confinement boundary for the spent fuel.

The 24PT1-DSC has redundant welds which join the shell and the top cover plate assemblies to form the confinement boundary. The cylindrical shell and inner bottom cover plate confinement boundary welds are fully compliant to Subsection NB of the ASME Code and are made during fabrication. The top closure confinement welds are made after fuel loading. Both top plug penetrations (siphon and vent ports) are welded after drying operations are complete. There are no credible accidents which could breach the confinement boundary of the 24PT1-DSC.

Subsection I.1.2.3 summarizes the allowable contents for the canister. Section I.2.1 provides the detailed specifications for the contents authorized for storage in the HI-STORM UMAX system.

The internal basket assembly contains a storage cell for each fuel assembly. The criticality analysis credits the fixed borated neutron absorbing material Boral™, placed between the fuel assemblies.

Structural support for the PWR fuel and basket cells is provided by circular spacer disc plates. Axial support for the basket assembly is provided by four support rods, which extend over the full length of the cavity with appropriate allowance for thermal growth of the rods.

There are no permanent lifting devices used for lifting a loaded 24PT1-DSC, as the canister is always within a transfer cask, and a custom engineered *Canister Handling Apparatus* is used during handling.

HOLTEC INTERNATIONAL COPYRIGHTED MATERIAL	
HI-2115090	Proposed Rev. 3.E
I.1-4	

A detailed description of the canister is found in Reference [I.1.2.1], with key parameters shown in Table I.1.2-1.

I.1.2.1.2 HI-STORM UMAX VVM

The generic design of the HI-STORM UMAX VVM, described in Section 1.2 (in the main body of the FSAR) is used in the storage of the 24PT1-DSC canisters, with the following modifications. The “UMAX” is designed to have improved seismic resistance by using a *Top Seismic Restraint Assembly* (TSRA) which interfaces with the *Divider Shell Appurtenance* (DSA) to eliminate the canister-to-CEC Shell gap within the VVM at the canister’s top lid elevation. [

PROPRIETARY INFORMATION WITHHELD PER 10CFR2.390

]

As can be seen from the licensing drawings in Section I.1.5, the radial thickness of the TSRA can be selected to accord with the diameter of the canister. Thus, this design feature will apply to all currently certified canisters as well as those that may be added to the systems’ Technical Specification in the future.

From the thermal-hydraulics standpoint, the TSRA is an inconsequential change because it does not materially increase or reduce flow resistance to the ventilation action. Additionally, it has no consequence to other safety metrics of the system such as shielding and criticality.

HOLTEC INTERNATIONAL COPYRIGHTED MATERIAL	
HI-2115090	Proposed Rev. 3.E
I.1-5	

1.2.1.2.1 Canister Licensing Basis

As the 24PT1-DSC is originally fabricated and loaded under CoC 72-1029, prior to being transferred to the HI-STORM UMAX system, the licensing basis for these canisters includes the NUHOMS FSAR as incorporated by reference into this supplement. However, each individual canister may have screenings and evaluations under the allowances of 10CFR72.48 as part of the canister licensing basis. Therefore, prior to transferring a 24PT1-DSC canister into the HI-STORM UMAX system, these 72.48s must be reviewed. Any changes outside of the information described in this FSAR (including the licensing drawings), will be evaluated under 10CFR72.48 against the HI-STORM UMAX FSAR to determine if the canister can be stored in the HI-STORM UMAX system or if further NRC approval is required.

1.1.2.1.3 The HI-TRAC VW Transfer Cask

The HI-TRAC VW, as described in Section 1.2 of the UMAX FSAR, (and originally licensed in the HI-STORM FW FSAR (Reference [I.1.2.3]) is engineered to be used to perform all short-term operations on the 24PT1-DSC, which begin with removal of the loaded, sealed, dry canister from its existing location (for example, NUHOMS transfer cask) and end with the emplacement of the canister in the HI-STORM UMAX VVM. The transfer cask is also used for short term unloading operations beginning with the removal of the canister from the storage overpack and ending with fuel unloading.

The HI-TRAC VW is designed to meet the following specific performance objectives that are centered on ALARA and physical safety of the plant's operations staff.

- a. Provide maximum shielding to the personnel engaged in conducting short-term operations.
- b. Provide protection of the canister against extreme environmental phenomena loads, such as tornado-borne missiles, during short-term operations.
- c. Provide the means to restrain the canister from sliding and protruding beyond the shielding envelope of the transfer cask under a (postulated) handling accident.
- d. Facilitate the transfer of a loaded canister to or from the HI-STORM UMAX VVM.

A structural ancillary termed the "Canister Handling Apparatus" (or CHA) is needed to enable the HI-TRAC VW cask to receive the horizontal canister, upright it, and deliver it to the "UMAX" storage cavity. The CHA is engineered to serve as a special lifting device, meeting the criteria in Sub-section 1.2.1.5 of [I.1.2.3], capable of handling the loaded weight of the canister in full accord with the stress limits of ANSI-N14.6 [I.1.2.4], which requires minimum safety factors of six and ten, respectively, against the material yield and ultimate strength of the primary load bearing members at ambient temperature.

1.1.2.1.3 Design Life

The Design Life of the HI-STORM UMAX System is discussed in Subsection 1.2.3.4 of the main body of this FSAR. The design life of the 24PT1-DSC canister is 50 years, due to the use

HOLTEC INTERNATIONAL COPYRIGHTED MATERIAL	
HI-2115090	Proposed Rev. 3.E
I.1-6	

of materials known to withstand their operating environments with little to no degradation, as described in Reference [I.1.2.1].

The licensing life of the canister is based on the license life of the canister and its initial loading date. This submittal does not seek a life extension of the licensed life of the 24PT1-DSC canister. Thus the license life of the HI-STORM UMAX VVM may be different from that of the canister.

I.1.2.2 Operational Characteristics

The HI-TRAC VW equipped with the above-mentioned Canister Handling Apparatus is used for on-site transport of the loaded canister to the ISFSI from its previous NUHOMS module to HI-STORM UMAX. The changes to the principal operational evolutions for the HI-STORM UMAX System to store 24PT1-DSC canisters are presented in Supplement I.9.

I.1.2.2.1 Design Features

The design features of the overall HI-STORM UMAX System are described in Paragraph 1.2.4.1. The design features of the 24PT1 canister are specifically related to maintaining subcriticality, confinement of radioactive material, and ensuring retrievability of contents.

Supplement I.11 identifies the many design features built into the HI-STORM UMAX system containing a 24PT1-DSC canister to minimize dose and maximize personnel safety. Among the design features intrinsic to the system that facilitate meeting the above objectives are:

1. The loaded canister is always handled using the HI-TRAC transfer cask and its ANSI N14.6 compliant CHA, which ensures full structural lifting support for the 24PT1 as it is transferred from the horizontal to vertical position.
2. Almost all personnel activities during canister transfer occur at ground level, which helps promote personnel safety and ALARA.

I.1.2.2.2 Sequence of Operations

A detailed sequence of steps for transfer and handling operations is provided in Supplement I.9 aided by illustrative figures, to serve as the guidance document for preparing site-specific implementation procedures. The transfer sequence described therein underscores the inherent simplicity of the evolutions and their compliance with ALARA principles.

It is important to note that this supplement only covers the operations for transfer of a previously loaded, sealed, dried, and backfilled 24PT1-DSC canister. It is a condition of the HI-STORM UMAX license that the 24PT1-DSC canister be previously loaded and certified to an approved Part 72 license, prior to transfer under the HI-STORM UMAX license.

HOLTEC INTERNATIONAL COPYRIGHTED MATERIAL	
HI-2115090	Proposed Rev. 3.E
I.1-7	

I.1.2.2.3 Identification of Subjects for Safety and Reliability Analysis

I.1.2.2.3.1 Criticality

Criticality is controlled by geometry and neutron absorbing materials in the fuel basket. The basket is made from stainless steel, with a fixed borated neutron absorbing material known as Boral™, which ensures criticality control of the fuel. The canister is maintained in a sealed, dried condition, so the criticality evaluations are unchanged. The criticality safety of the DSC-24PT1 canister has been demonstrated in Chapter 6 of [I.1.2.1].

I.1.2.2.3.2 Chemical Safety

There are no chemical safety hazards associated with operations of the 24PT1 canister within the HI-STORM UMAX System.

I.1.2.2.3.3 Operation Shutdown Modes

The HI-STORM UMAX System is totally passive and consequently there are no operational shutdown modes to evaluate.

I.1.2.2.3.4 Instrumentation

The 24PT1-DSC canister provides the confinement for the radioactive contents. The HI-STORM UMAX with the 24PT1-DSC canister is a completely passive system with appropriate margins of safety; therefore it is not necessary to deploy any instrumentation to monitor the cask in the storage mode. At the option of the user, temperature elements may be utilized to monitor the air temperature of the HI-STORM UMAX outlet vents in lieu of routinely inspecting the vents for blockage.

I.1.2.2.3.5 Maintenance Technique

Because of its passive nature, the HI-STORM UMAX System with the 24PT1-DSC canister requires minimal maintenance over its lifetime. The maintenance program for the system, specific to those bearing the 24PT1-DSC canister is addressed in Supplement I.10.

I.1.2.3 Cask Contents

The 24PT1-DSC is designed to house PWR spent nuclear fuel assemblies. A complete description of acceptable fuel assemblies for storage in the 24PT1-DSC canister is provided in Section I.2.1. This description includes any fuel assemblies classified as damaged or fuel debris, as applicable. All fuel assemblies, non-fuel hardware, and neutron sources authorized for packaging in the 24PT1-DSC canister within the HI-STORM UMAX system must meet the fuel specifications provided in Section I.2.1.

HOLTEC INTERNATIONAL COPYRIGHTED MATERIAL	
HI-2115090	Proposed Rev. 3.E
I.1-8	

Table I.1.2.1 Key System Data for 24PT1 Canister

Parameter	24PT1 Canister
Design Temperature, max / min (°F) (Note 2)	Off normal (ambient): 100 / -40 Normal (ambient): 80 / -40 Extreme (ambient): 125/-40 Component design temperatures in Table 4.1-3 of Reference [I.1.2.1]
Design internal pressure (psig) (Note 2)	(from Table 3.1-6 of Reference [I.1.2.1])
Normal Conditions	10
Off-normal Conditions	20
Accident Conditions	60
Total heat load, max (Kw)	14
Maximum permissible peak fuel cladding temperature:	
Long Term Normal (°F)	752 (Note 1)
Short Term Operations (°F)	1058 (Note 1)
Off-normal and Accident (°F)	1058 (Note 1)
Maximum permissible multiplication factor (k_{eff}) including all uncertainties and biases (Note 2)	<0.95
Neutron Absorber ¹⁰ B Areal Density (g/cm ²) (Note 2)	0.019 (from Table 6.5-4 of Reference [I.1.2.1])
End closures (Note 2)	Welded
Heat dissipation (Note 2)	Passive

Note 1: Fuel Temperature limits aligned with ISG-11, Rev. 3 [I.2.0.5] mandated limits.

Note 2: HI-STORM UMAX operating temperature limits adopted herein

HOLTEC INTERNATIONAL COPYRIGHTED MATERIAL	
HI-2115090	Proposed Rev. 3.E
I.1-9	

I.1.3 Identification of Agents and Contractors

As described in Section 1.3, Holtec International is the company responsible for the design and fabrication of the HI-STORM UMAX System. The Holtec quality assurance program, which satisfies all 18 criteria in 10 CFR 72, Subpart G, that apply to the design, fabrication, construction, testing, operation, modification, and decommissioning of structures, systems, and components important to safety is incorporated by reference into this FSAR. Holtec International’s QA program has been certified by the US NRC (Docket Number 71-0784).

The 24PT1-DSC canister is an NRC-approved canister that was manufactured under Areva’s NRC-approved QA program and as such is admissible for storage in another NRC-approved storage system (HI-STORM UMAX), following performance of appropriate evaluations. Holtec International does not plan to manufacture the 24PT1-DSC canister; this FSAR is limited to demonstrating the regulatory compliance of the loaded 24PT1-DSC canisters at ISFSIs that meet the content conditions and other requirements summarized in the associated Technical Specifications.

HOLTEC INTERNATIONAL COPYRIGHTED MATERIAL	
HI-2115090	Proposed Rev. 3.E
I.1-10	

I.1.4 Generic Cask Arrays

The 24PT1-DSC canister is stored in a vertical configuration within the HI-STORM UMAX system. The required center-to-center spacing between the modules (layout pitch) is guided by operational considerations such as size, accessibility, security, dose, and functionality. The 24PT1-DSC canister may be deployed within a HI-STORM UMAX in a cask array as described in Section 1.4 of the main body of this FSAR, and no additional requirements apply to HI-STORM UMAX systems loaded with 24PT1-DSC canisters.

HOLTEC INTERNATIONAL COPYRIGHTED MATERIAL	
HI-2115090	Proposed Rev. 3.E
I.1-11	

I.1.5 Figures and Drawings

The licensing drawing for the HI-STORM UMAX System, pursuant to the requirements of 10CFR72.24(c)(3), is provided in Section 1.5 of the main body of this FSAR, with additional drawings applicable to the storage of the 24PT1-DSC canister contained in this section. The material list of the licensing drawing contains sufficient information to articulate major design features and general operational characteristics of the “UMAX” system. Further, it is intended to serve as the control information to guide the preparation of the documents required to manufacture the components under Holtec’s Quality Assurance Program. Holtec’s Quality Assurance Program requires that the entire array of manufacturing documents must remain in complete conformance with the Licensing Drawing Package at all times.

[PROPRIETARY DRAWINGS WITHHELD PER 10CFR2.390]

HOLTEC INTERNATIONAL COPYRIGHTED MATERIAL	
HI-2115090	Proposed Rev. 3.E
I.1-12	

I.1.6 References

- [I.1.2.1] AREVA Inc. (formerly Transnuclear, Inc.), “Updated Final Safety Analysis Report for the Standardized Advanced NUHOMS Horizontal Modular Storage System for Irradiated Nuclear Fuel”, Revision 6 (Non-Proprietary Version), Docket 72-1029, August 2014. Compiled from ML050410252, ML031040379, ML031040312, ML040910311, ML082341022, ML102290084, ML12229A121, and ML14226A790

- [I.1.2.2] U.S. Nuclear Regulatory Commission, “Final Safety Evaluation Report Transnuclear, Inc. Standardized Advanced NUHOMS Horizontal Modular Storage System for Irradiated Nuclear Fuel”, Amendment No. 3, Docket 72-1029, February 20, 2015.

- [I.1.2.3] Holtec International, “Final Safety Analysis Report on the HI-STORM FW MPC Storage System”, HI-2114830 Revision 4, Docket 72-1032, ML15177A246..

- [I.1.2.4] American National Standards Institute “American National Standard for Radioactive Materials – Special Lifting Devices for Shipping Containers Weighing 10,000 Pounds (4,500 Kg) or More”, ANSI/ANS N14.6-1993, New York, New York.

HOLTEC INTERNATIONAL COPYRIGHTED MATERIAL	
HI-2115090	Proposed Rev. 3.E
I.1-13	

SUPPLEMENT I.2: PRINCIPAL DESIGN CRITERIA

I.2.0 OVERVIEW OF THE PRINCIPAL DESIGN CRITERIA*

I.2.0.1 General

This supplement provides a systematic presentation of the loadings that must be considered for a complete safety evaluation of the 24PT1-DSC canister in the context of its storage within the HI-STORM UMAX System. As discussed in Section I.1.0, this Supplement incorporates the previously approved DSC under Docket No. 72-1029 to be stored in a HI-STORM UMAX Vertical Ventilated Module (VVM). Although the safety analyses of this previously certified canister are described in the Standardized Advanced NUHOMS FSAR [I.1.2.1], additional safety evaluations are necessary to ensure that the canister continues to meet all design criteria when stored in the HI-STORM UMAX VVM.

Section I.1.5 contains the licensing drawings for UMAX system components specific to transfer and storage of the 24PT1-DSC within the HI-STORM UMAX VVM, including relevant details of the canister. Licensing drawings for generic system components (VVM and HI-TRAC) utilized during storage of all authorized canisters are provided in Section 1.5 of this FSAR.

For components that are common to all canisters allowable for storage in the HI-STORM UMAX System (specifically the VVM and HI-TRAC), design criteria are referenced in this supplement, as appropriate, back to the main body of this HI-STORM UMAX FSAR. In addition, as the 24PT1-DSC canister has already been approved by the NRC for storage under Part 72, much of the safety analysis information is incorporated by reference into this Supplement as documented in Table I.2.0.1.

The 24PT1-DSC canister design life pursuant to the provisions in 10 CFR 72, is discussed in Subsection I.1.2.1. The adequacy of the 24PT1-DSC canister to meet the above design life is discussed in Section 3.4 of the Standardized Advanced NUHOMS FSAR [I.1.2.1]. The design characteristics of the 24PT1-DSC canister are described in Section I.1.2 of this Supplement.

The applicable loads, affected parts under each loading condition, and the applicable structural acceptance criteria are compiled in this Supplement (I.2) to provide a complete framework for the required qualifying safety analyses in the rest of this Supplement to the Safety Analysis Report. Information consistent with the regulatory requirements related to shielding, thermal performance, criticality, confinement, radiological, and operational considerations is also provided.

Supplement I adds the 24PT1-DSC canister to the HI-STORM UMAX system. Only those design features, analyses and evaluations of “UMAX” that are revised or added to incorporate the 24PT1-DSC canister are described in this supplement. This supplement also references to the main body of the FSAR where existing safety analyses are bounding, as applicable.

* The reader should refer to Section 1 in Chapter 1 of this supplement (identified as Section I.1.0) for the numbering convention for chapters, sections, etc.

HOLTEC INTERNATIONAL COPYRIGHTED MATERIAL	
HI-2115090	Proposed Rev. 3.E
HI-STORM UMAX Supplement I Rev 3I	I.2.1 14 of 282

I.2.0.2 Structural

As documented in NRC Docket Number 72-1029, the design criteria for the 24PT1-DSC canister satisfy the requirements of 10 CFR Part 72, when stored in the NUHOMS modules. These criteria include the effects of normal operation, natural phenomena, and postulated accidents. The loading conditions, classified by Service Level consistent with Section III of the ASME Boiler and Pressure Vessel Code [I.2.0.2] for storage in the HI-STORM UMAX are evaluated in this supplement. The type and magnitude of stresses in the canister's Confinement Boundary resulting from the application of these loads are then evaluated based on the rules for a Class I nuclear component prescribed by Subsection NB of the Code.

The welding materials required to make the closure welds on the 24PT1-DSC canister inner and outer top cover plates are evaluated to the same ASME Code criteria as the canister shell (Subsection NB, Class 1). Per [I.2.0.3], the Confinement Boundary welds were inspected, tested and examined in accordance with the ASME Code Subsection NB.

The 24PT1-DSC canister provides the fuel assembly support required to maintain the fuel geometry for criticality control. The 24PT1-DSC canister also provides the confinement boundary for radioactive materials. Therefore, the 24PT1-DSC canister is designed to remain intact under all accident conditions identified in Supplement I.12 without failing in its mission to provide confinement of the spent fuel assemblies.

As demonstrated in Chapter I.3 of this supplement, the inertia loads on the canister are significantly lower than those for which it is qualified in its native docket because the canister is restrained from any kinematic movement during the seismic event (see Supplement I.3). Likewise, the subterranean configuration of the canister storage in the "UMAX" VVM protects the canister from other mechanical and inertial loadings. Thus the analytical evaluation of the canister's structural safety reduces to its seismic analysis under the specified design basis earthquake (denoted as the Most Severe Earthquake or MSE in this FSAR).

I.2.0.3 Thermal

The temperature criteria used in the 24PT1-DSC canister thermal evaluation are intended to ensure safe storage and handling of spent fuel assemblies in accordance with the requirements of 10 CFR 72 in order to reduce the probability of rod failure during normal, off-normal, short-term operations and hypothetical accident conditions to extremely low levels. The acceptance criteria apply for the fuel types listed in Table I.2.1.1.

The thermal design and operation of the 24PT1-DSC canister in the HI-STORM UMAX System must meet the intent of the guidance contained in ISG-11, Revision 3 [I.2.0.5]. Specifically, provisions in Subsection 2.0.3 of the main body of this FSAR may be applied to the 24PT1-DSC canister; with the following modifications:

- a) Maximum burnup of approved assemblies is less than or equal to the burnup provided in Table I.2.1.2. High burnup fuel (HBF) is not authorized for storage in the 24PT1-DSC.
- b) Canister drying operations are not applicable to this supplement, as this supplement permits storage of a previously loaded canister in the UMAX.

HOLTEC INTERNATIONAL COPYRIGHTED MATERIAL	
HI-2115090	Proposed Rev. 3.E
I.2-2	

c) The maximum decay heat per assembly and maximum heat load per canister are provided in Table I.2.1.2 (for UO₂ and MOX assemblies).

The thermal evaluation for the 24PT1-DSC canister containing the design basis fuel for storage within the HI-STORM UMAX is performed in Supplement I.4.

I.2.0.4 Shielding

The design criteria, including the dose rate limits at the controlled area boundary, as described in Section 2.0.4 of the main body of this FSAR applies to the shielding of the 24PT1-DSC canister within the HI-STORM UMAX. The shielding evaluation for the 24PT1-DSC containing the design basis fuel for storage within the HI-STORM UMAX is reported in Chapter I.5 of this Supplement.

I.2.0.5 Criticality

The 24PT1-DSC canister provides criticality control for all design basis normal, off-normal, short-term operations and hypothetical accident conditions, as described in the Standard NUHOMS FSAR [I.1.2.1] and incorporated herein by reference, Table I.2.0.1 contains summary information. The design criterion for criticality calls for the effective neutron multiplication factor, k_{eff} , including statistical uncertainties and bias, to be less than 0.95 for all postulated arrangements of fuel within the canister. The 24PT1-DSC canister incorporates Boral sheets as fixed neutron absorbing materials to provide criticality control.

As the canisters are loaded in an approved configuration such as to maintain the spent fuel in a subcritical state following the methodology and criteria described in the NRC approved FSAR [I.1.2.1], there are no deviations from the criticality control design and procedures resulting from storage in the HI-STORM UMAX. Additionally, the same allowable contents are authorized in storage in the HI-STORM UMAX as in the original license, which ensures there are no new criticality evaluations needed. The HI-STORM UMAX VVM does not perform criticality control function. Accordingly, reference to Section 2.3.4 of the Standardized Advanced NUHOMS FSAR [I.1.2.1] is made for the design criteria on criticality control.

I.2.0.6 Confinement

The confinement design criteria are incorporated by reference from the Standardized Advanced NUHOMS FSAR [I.1.2.1], specifically as described in Table I.2.0.1. The canisters are designed and analyzed to maintain the confinement of the radioactive materials (spent fuel assemblies and associated contaminated or activated materials) following the methodology and design configuration described in the NRC approved FSAR. The 24PT1-DSC canister is designed and tested to be “leak-tight” as defined in ANSI N14.5 [I.2.2.3]. There are no deviations from the confinement barriers and system design caused by storage in the HI-STORM UMAX, which does not perform confinement function. Accordingly, reference is made to Section 2.3.2 of the Standardized Advanced NUHOMS FSAR [I.1.2.1] for the design criteria on confinement barriers and systems.

HOLTEC INTERNATIONAL COPYRIGHTED MATERIAL	
HI-2115090	Proposed Rev. 3.E
I.2-3	

I.2.0.7 Operations

The design criteria as described in Section 2.0.7 of the main body of this FSAR applies to the operations pertaining to the 24PT1-DSC canister stored within the HI-STORM UMAX. Generic operating procedures for the HI-STORM UMAX System are provided in Chapter 9 of the main body FSAR and any specific operations or deviations relating to the handling of the 24PT1-DSC canister are provided in Chapter I.9 of this Supplement. Detailed operating procedures will be developed by the licensee using the information provided in Chapter 9 and Supplement I.9 along with the site-specific ISFSI requirements that comply with applicable Certificate(s) of Compliance (CoC).

I.2.0.8 Acceptance Tests and Maintenance

The acceptance tests for the 24PT1-DSC canister, including all pre-operational tests, are performed prior to the spent fuel loading and are therefore covered by the Standardized Advanced NUHOMS CoC as described in the FSAR [I.1.2.1]. Therefore, this FSAR does not need to address the pre-operational testing program.

The requirements for the maintenance program as described in Subsection 2.0.8 of the main body of this FSAR also apply to the 24PT1-DSC canister stored within the HI-STORM UMAX. The maintenance program for the HI-STORM UMAX System is provided in Chapter 10 of the main body FSAR and any specific requirements or deviations relating to the maintenance of the 24PT1-DSC canister or aging management are provided in Chapter I.10 of this Supplement.

I.2.0.9 Decommissioning

The 24PT1-DSC canister may be transported off-site for decommissioning in a suitably certified HI-STAR, or the MP187 transport cask (NRC Docket 71-9255, [I.2.0.4]) approved for transport of the 24PT1-DSC. The decommissioning considerations for the HI-STORM UMAX including the 24PT1-DSC canister are discussed in Section I.2.10.

HOLTEC INTERNATIONAL COPYRIGHTED MATERIAL	
HI-2115090	Proposed Rev. 3.E
I.2-4	

Table I.2.0.1: Material Incorporated by Reference

Information Incorporated by Reference	Source of the Information	NRC Approval of Material Incorporated by Reference	Location in this FSAR where Material is Incorporated	Technical Justification of Applicability to HI-STORM UMAX
Canister Criticality Criteria	Standardized Advanced NUHOMS FSAR Section 2.3.4 [I.1.2.1]	Standardized Advanced NUHOMS SER, Amendment 0, Reference [I.2.0.3]	I.2.0.5	The canister is loaded under the NUHOMS CoC (NRC Docket 72-1029) following the design criteria described in the NUHOMS FSAR. Storage within the HI-STORM UMAX will not affect the criticality of the spent nuclear fuel stored in the canister, since the UMAX VVM does not perform criticality control.
Confinement Barriers and System Criteria	Standardized Advanced NUHOMS FSAR Section 2.3.2 [I.1.2.1]	Standardized Advanced NUHOMS SER, Amendment 0, Reference [I.2.0.3]	I.2.0.6, I.2.6.2	The canister is loaded under the NUHOMS CoC (NRC Docket 72-1029) following the design criteria described in the NUHOMS FSAR. Storage within the HI-STORM UMAX will not affect the confinement barriers of the spent nuclear fuel stored in the canister, since the UMAX VVM does not perform confinement function.
Canister Acceptance Test Criteria	Standardized Advanced NUHOMS FSAR Sections 9.1 & 9.2 [I.1.2.1]	Standardized Advanced NUHOMS SER, Amendment 0, Reference [I.2.0.3]	I.2.0.8	The fabrication and performance of the canister is evaluated against the acceptance criteria prior to loading or storage. Therefore, it is ensured that the canister has met the acceptance criteria before it is placed for storage within the HI-STORM UMAX.
Canister Criticality Analysis	Standardized Advanced NUHOMS FSAR Chapter 6 [I.1.2.1]	Standardized Advanced NUHOMS SER, Amendment 0, Reference [I.2.0.3]	I.2.7	The canister is loaded under the NUHOMS CoC (NRC Docket 72-1029) following the design criteria and analyses described in the NUHOMS FSAR. Storage within the HI-STORM UMAX will not affect the criticality of the spent nuclear fuel stored in the canister.
Design Internal	Table 3.1.6 of Ref	Advanced	I.2.2.2.1	The canister is loaded and sealed under Docket

HOLTEC INTERNATIONAL COPYRIGHTED MATERIAL

HI-2115090

Proposed Rev. 3.E

Information Incorporated by Reference	Source of the Information	NRC Approval of Material Incorporated by Reference	Location in this FSAR where Material is Incorporated	Technical Justification of Applicability to HI-STORM UMAX
DSC Pressure	[I.1.2.1]	NUHOMS SER, Amendment 0, Reference [I.2.0.3]		Number 72-1029, and there is no change to the contents, including helium gas, fuel rods, or their fill gas. Therefore, the only parameter relating to the pressure inside the DSC that may be different during storage in the HI-STORM UMAX System is the MPC temperature. The analyses in Supplement I.4 show that all temperatures of the DSC in the HI-STORM UMAX are bounded by those already approved in the NUHOMS module.

HOLTEC INTERNATIONAL COPYRIGHTED MATERIAL

HI-2115090

Proposed Rev. 3.E

I.2.1 SPENT FUEL TO BE STORED AND SERVICE LIMITS

I.2.1.1 Determination of Design Basis Fuel

The 24PT1-DSC canister has currently been designed for the storage of 24 Westinghouse 14x14 (WE 14x14) PWR fuel assemblies. This payload consists of intact and/or damaged WE 14x14 assemblies including stainless steel or zircaloy cladding, UO₂ or mixed-oxide (MOX) fuel pellets, with or without integral control components, and/or damaged fuel. Integral control components, otherwise known as Non-Fuel Hardware (NFH), stored in the 24PT1-DSC are limited to Rod Cluster Control Assemblies (RCCAs), Thimble Plug Assemblies (TPAs), and Neutron Source Assemblies (NSAs). Payload may include fuel assemblies utilizing boron coated fuel pellets.

The thermal and radiological characteristics for the PWR spent fuel were generated using the SCALE computer code package. Spent fuel with various combinations of burnup, decay heat, enrichment, and cooling time can be stored in the 24PT1-DSC as long as the values for decay heat, gamma and neutron sources, including spectra, remain within the design limits specified in Table I.2.1.2. Specific gamma and neutron source spectra are given in Supplement I.5.

Although analyses in the approved Standardized Advanced NUHOMS FSAR and in Supplement I are performed only for the design basis fuel, any other PWR fuel which falls within the geometric, thermal, and nuclear limits in Tables I.2.1.1, I.2.1.2 and I.2.1.3 can be stored in the 24PT1-DSC canister. As can be observed in Table I.2.1.2, high burnup fuel is not authorized for storage in the 24PT1-DSC.

I.2.1.2 Undamaged/Intact SNF Specifications

Undamaged or Intact SNF assembly is defined as fuel assembly without known or suspected cladding defects greater than pinhole leaks or hairline cracks.

I.2.1.3 Damaged SNF and Fuel Debris Specifications

Damaged fuel may include assemblies with known or suspected cladding defects greater than hairline cracks or pinhole leaks, up to and including broken rods, portions of broken rods and rods with missing sections. Damaged fuel assemblies are encapsulated in individual failed fuel cans that confine any loose material and gross fuel particles to a known, subcritical volume during normal, off-normal and accident conditions and to facilitate handling and retrievability. The criticality analysis provided in Chapter 6 of the Standardized Advanced NUHOMS FSAR [I.1.2.1] requires that no more than 14 fuel pins (rods) in each assembly exhibit damage. A visual inspection of assemblies was performed prior to placement of the fuel in the 24PT1-DSC, which may then be placed in storage or transported anytime thereafter without further fuel inspection.

Each 24PT1-DSC canister can accommodate a maximum of four damaged WE 14x14 stainless steel clad (SC) fuel assemblies, with the remaining assemblies intact WE 14x14 SC assemblies. One damaged MOX assembly may also be accommodated, with the remaining assemblies (up to 23) intact WE 14x14 SC fuel assemblies.

HOLTEC INTERNATIONAL COPYRIGHTED MATERIAL	
HI-2115090	Proposed Rev. 3.E
I.2-7	

I.2.1.4 Structural Parameters for Design Basis SNF

The main physical parameters of an SNF assembly applicable to the structural evaluation are the fuel assembly length, cross sectional dimensions, and weight. These parameters, which define the mechanical and structural design, are specified in Table I.2.1.1.

The stainless steel clad fuel assembly without Rod Cluster Control Assemblies (RCCAs), Neutron Source Assemblies (NSAs), or Thimble Plug Assemblies (TPAs) is used for stability calculations (wind, tornado, missiles, flood and seismic) due to the lighter weight of the contents and the slightly higher center of gravity.

As specified in the canister's native FSAR [I.2.0.3], the 24PT1-DSC canister may also include two empty fuel slots and/or multiple dummy fuel assemblies. Dummy assemblies have approximately the same weight and center of gravity as a SC fuel assembly. The empty slots must be located at symmetrical locations about the 0-180° and 90-270° axes.

As the NUHOMS FSAR states, the reduction in weight due to two empty slots will tend to slightly reduce stresses for the 24PT1-DSC canister for the various load conditions. Empty slots and/or multiple dummy fuel assemblies will not have any other impact on the structural analysis based on the controls imposed on the dummy assembly size and center of gravity, and the center of gravity location for a 24PT1-DSC with empty slots.

I.2.1.5 Thermal Parameters for Design Basis SNF

The principal thermal design parameter for the stored fuel is the fuel's peak cladding temperature (PCT). To ensure the permissible PCT limits are not exceeded, Subsection I.2.1.9 specifies the maximum allowable decay heat per assembly for the 24PT1-DSC canister.

The thermal characteristics for the design basis spent fuel assembly are provided in Table I.2.1.2. The thermal characteristics for the non-fuel assembly hardware are provided in Table I.2.1.3. The values reported for the non-fuel assembly hardware are consistent with the cumulative exposures and cooling times of the fuel assemblies. As described in Supplement I.4, a heat generation rate is applied to the design basis fuel for the UMAX thermal analysis that bounds the axial heat generation rate profile in the NUHOMS FSAR [I.1.2.1]. The distribution is for analysis only, and does not provide criteria for fuel assembly acceptability for storage in the HI-STORM UMAX System. Bounding axial heat generation distribution is based on Reference [I.2.1.1] and provided in Table I.2.1.4.

The effect of two empty slots and/or multiple dummy fuel assemblies on the thermal analysis is bounded by the 24 fuel assembly analyses since these configurations result in heat loads less than the design basis, thus reducing the 24PT1-DSC and by extension the UMAX VVM temperatures. The effect of these configurations on the 24PT1-DSC thermal stresses may result in a slight increase in spacer disc thermal stresses if the empty slots and/or dummy assemblies are located on the outer perimeter of the 24PT1-DSC. However, this effect is localized and will not impact the controlling 24PT1-DSC canister structural analysis load combinations (these load conditions exclude thermal stresses).

HOLTEC INTERNATIONAL COPYRIGHTED MATERIAL	
HI-2115090	Proposed Rev. 3.E
I.2-8	

I.2.1.6 Radiological Parameters for Design Basis SNF

The principal radiological design criteria for the HI-STORM UMAX System are the 10CFR72 §104 and §106 operator-controlled boundary dose rate limits and the requirement to maintain operational dose rates as low as reasonably achievable (ALARA). The radiation dose is directly affected by the gamma and neutron source terms of the assembly, which is a function of the assembly type, and the burnup, enrichment and cooling time of the assemblies. Dose rates are further directly affected by the size and arrangement of the ISFSI and the specifics of the loading operations. All these parameters are site-dependent, and the compliance with the regulatory dose rate requirements are performed in site-specific calculations. The evaluations here are therefore performed with reference fuel assemblies and with parameters that result in reasonably conservative dose rates.

The radiological characteristics for the 24PT1-DSC canister design basis spent fuel assembly are provided in Table I.2.1.2. The radiological characteristics for the non-fuel assembly hardware are provided in Table I.2.1.3. The values reported for the non-fuel assembly hardware are consistent with the cumulative exposures and cooling times of the fuel assemblies. A bounding axial burnup distribution profile for the radiological source terms is identical to that provided in the main body of this report in Table 2.1.5 and Figure 2.1.1. The distribution is used for analysis purposes only, and does not provide a criterion for fuel assembly acceptability for storage in the HI-STORM UMAX.

The effect of two empty slots and/or multiple dummy fuel assemblies on the shielding analysis is bounded by the 24 fuel assembly analyses since the neutron and gamma source terms are reduced.

I.2.1.7 Criticality Parameters for Design Basis SNF

Criticality control in the 24PT1-DSC canister is provided by the basket structural components that maintain the relative position of the spent fuel assemblies under all normal, off-normal and accident conditions and by fixed neutron absorbing materials.

The effect of two empty slots and/or multiple dummy fuel assemblies on the criticality analysis is bounded by the analyses for 24 fuel assemblies due to the reduction in the source of neutrons. The storage location in which the dummy assembly or empty slot is located sees the same number of neutrons entering the region from adjacent assemblies but does not generate additional neutrons since no fuel is present. The analyzed case of the 24PT1-DSC DSC loaded to capacity with fuel and moderated in the NUHOMS FSAR [I.1.2.1] bounds the unmoderated case when the canister is partially loaded.

I.2.1.8 Summary of Authorized Contents

Tables I.2.1.1 through I.2.1.3 specify the limits for spent fuel and non-fuel hardware authorized for storage in the 24PT1-DSC canister within the HI-STORM UMAX System. The limits in

HOLTEC INTERNATIONAL COPYRIGHTED MATERIAL	
HI-2115090	Proposed Rev. 3.E
I.2-9	

these tables are derived from the safety analyses described in Supplement I of this FSAR as well as in the NRC approved Standardized Advanced NUHOMS FSAR [I.1.2.1].

I.2.1.9 Permissible Heat Load for the 24PT1-DSC Canister

The 24PT1-DSC canister is previously licensed in USNRC Docket 72-1029 for storage of spent fuel with design basis decay heat per assembly/canister as specified in Table I.2.1.2.

HOLTEC INTERNATIONAL COPYRIGHTED MATERIAL	
HI-2115090	Proposed Rev. 3.E
I.2-10	

Table I.2.1.1 Spent Fuel Assembly Physical Characteristics

Parameter	WE 14 x 14 SC	WE 14 x 14 MOX ⁽¹⁾
Number of Rods	180	180
Number of Guide Tubes/ Instrument Tubes	16	16
Cross Section (in)	7.763	7.763
Unirradiated Length (in)	138.5	138.5
Fuel Rod Pitch (in)	0.556	0.556
Fuel Rod Outer Diameter (in)	0.422	0.422
Clad Material	Type 304 SS	Zircaloy-4
Clad Thickness (in)	0.0165	0.0243
Pellet Outer Diameter (in)	0.3835	0.3659
Max. Initial ²³⁵ U Enrichment (% wt)	4.05	Note 2
Theoretical Density (%)	93-95	91
Active Fuel Length (in)	120	119.4
Max. U Content (kg)	375	Note 3
Average U Content (kg)	366.3	Note 3
Assembly Weight (lbs)	1210	1150
Max. Assembly Weight including NFAH ⁽⁴⁾ (lbs)	1320	1320

- (1) Nominal values shown unless otherwise stated
- (2) Mixed-Oxide assemblies with 0.71 weight % U-235 and fissile Pu weight of 2.84 weight % (64 rods), 3.10 weight % (92 rods), and 3.31 weight % (24 rods)
- (3) Total weight of Pu is 11.24 kg and the total weight of U is 311.225 kg
- (4) Weights of TPAs and NSAs are enveloped by RCCAs

HOLTEC INTERNATIONAL COPYRIGHTED MATERIAL	
HI-2115090	Proposed Rev. 3.E
I.2-11	

Table I.2.1.2 Spent Fuel Assembly Thermal and Radiological Characteristics

Parameter	WE 14 x 14 SC	WE 14 x 14 MOX ⁽¹⁾
Initial ²³⁵ U Enrichment (% wt)	3.12 – 4.05	Note 1
Maximum Burnup (MWd/MTU)	45,000	25,000
Minimum Cooling Time (years)	20 ⁽⁵⁾	20
Maximum Decay Heat (kW/Canister) ⁽⁴⁾	14	13.706
Maximum Decay Heat (kW/assembly) ⁽⁴⁾	0.581 ⁽³⁾ or less	0.292 ⁽³⁾ or less
Gamma Source (γ /sec/assembly) ⁽²⁾	3.43E+15	9.57E+14
Neutron Source (n/sec/assembly) ⁽²⁾	2.84E+08	4.90E+07

- (1) Mixed-Oxide assemblies with 0.71 weight % U-235 and fissile Pu weight of 2.84 weight % (64 rods), 3.10 weight % (92 rods), and 3.31 weight % (24 rods).
- (2) Gamma/neutron source spectrum by energy group is presented in Supplement I.5.
- (3) Decay heat for fuel assembly excluding control components. Decay heat for control components is specified in Table I.2.1.3.
- (4) Decay heat limits provided in this table is applicable damaged and intact fuel assemblies.
- (5) Historically, all United States commercial reactors that had used stainless steel cladding have been shut down, with the last such plant being Connecticut Yankee (Haddam Neck), which shut down in 1996 [I.2.1.2],[I.2.1.3]. For this reason, there is no discharged spent fuel with stainless steel cladding in storage that has a cooling time shorter than that displayed above in Table I.2.1.2.

HOLTEC INTERNATIONAL COPYRIGHTED MATERIAL	
HI-2115090	Proposed Rev. 3.E
I.2-12	

**Table I.2.1.3 Non-Fuel Assembly Hardware Thermal and Radiological Characteristics
(Note 1)**

Parameter	RCCAs	TPAs	NSAs
Gamma Source (γ /sec/assembly)(Note 2)	7.60E+12	5.04E+12	1.20E+13
Decay Heat (Watts)	1.90	1.2	1.66

Notes:

- (1) The thermal and radiological source terms for Non-Fuel Assembly Hardware (NFAH) includes Rod Cluster Control Assemblies (RCCAs), Neutron Source Assemblies (NSAs) or Thimble Plug Assemblies (TPAs).
- (2) Gamma source by energy group is presented in Supplement I.5.

HOLTEC INTERNATIONAL COPYRIGHTED MATERIAL	
HI-2115090	Proposed Rev. 3.E
I.2-13	

Table I.2.1.4 Thermal Axial Burnup Profile (Note 1)

Axial Position (% of Core Height)	Normalized Burnup (Fraction of Assembly Average)
2.78	0.652
8.33	0.967
13.89	1.074
19.44	1.103
25.00	1.108
30.56	1.106
36.11	1.102
41.67	1.097
47.22	1.096
52.78	1.094
58.33	1.095
63.89	1.096
69.44	1.095
75.00	1.086
80.56	1.059
86.11	0.971
91.67	0.738
97.22	0.462

Note 1: The information in this table is incorporated verbatim from [I.2.1.1], which is referenced by the Standardized Advanced NUHOMS System FSAR [I.1.2.1].

HOLTEC INTERNATIONAL COPYRIGHTED MATERIAL	
HI-2115090	Proposed Rev. 3.E
I.2-14	

I.2.2 SERVICE CONDITIONS AND APPLICABLE LOADS

I.2.2.1 Service Conditions

The loading categories as described in Section 2.2 and Subsection 2.3.1 of the main body of this FSAR apply to the service conditions of the HI-STORM UMAX VVM. These service conditions apply to the safety evaluation of the HI-STORM UMAX VVM for all the stored canisters, including the 24PT1-DSC.

I.2.2.2 Loadings Applicable to Normal Conditions of Storage

I.2.2.2.1 Pressure

The canister internal pressure is dependent on the initial volume of cover gas (helium), the volume of fill gas in the fuel rods, the fraction of fission gas released from the fuel matrix, the number of fuel rods assumed to have ruptured, and temperature.

For normal conditions, with the canister loaded with intact fuel rods/assemblies, 1% failure of the fuel rods and control components is assumed. For the ruptured rods, 100% release of the fuel rod fill gas and 30% release of the fission gas is assumed, based on the guidance in NUREG-1536 [I.2.2.1].

The canister is loaded and sealed under Docket Number 72-1029, and there is no change to the contents, including helium gas, fuel rods, or their fill gas. Therefore, the only parameter relating to the pressure inside the DSC that may be different during storage in the HI-STORM UMAX System is the DSC temperature. The analyses in Supplement I.4 show that all temperatures of the DSC in the HI-STORM UMAX are bounded by those already approved in the NUHOMS module. Therefore, all maximum internal pressures in the 24PT1-DSC will be less than the design pressures presented in Table 3.1-6 of Reference [I.1.2.1].

The pressure loading parameters in Subsection I.2.2.4 (100% Fuel Rod Rupture) bound the case for normal conditions, with the canister loaded with damaged fuel rods/assemblies.

I.2.2.2.2 Environmental Temperatures and Pressures

The ambient temperatures and pressures as described in Section 2.3.2.2 of the main body of this FSAR apply to the environmental loading evaluations of the HI-STORM UMAX VVM. These conditions apply to the safety evaluation of the HI-STORM UMAX VVM for all the stored canisters, including the 24PT1-DSC.

I.2.2.2.3 Design Temperatures

The ASME Boiler and Pressure Vessel Code (ASME Code) requires that the value of the vessel design temperature be established with appropriate consideration for the effect of heat generation internal or external to the vessel. The decay heat load from the spent nuclear fuel is the internal heat generation source for the HI-STORM UMAX System. Table 2.3.7 contains the Design Temperatures for the HI-STORM UMAX system and its associated systems, structures and

HOLTEC INTERNATIONAL COPYRIGHTED MATERIAL	
HI-2115090	Proposed Rev. 3.E
I.2-15	

components (SSCs). The Design Temperatures for the additional parts and components specific to the transfer and storage of the 24PT1-DSC canister are provided in Table I.2.2.1 for normal operating conditions.

I.2.2.2.4 Snow and Ice

The criteria for withstanding snow and ice loads as described in Paragraph 2.3.2.4 of the main body of this FSAR apply to the environmental loading evaluations of the HI-STORM UMAX VVM. These conditions apply to the safety evaluation of the HI-STORM UMAX VVM for all the stored canisters, including the 24PT1-DSC. The HI-STORM UMAX VVM and the HI-TRAC protect the 24PT1-DSC canister from snow and ice loads.

I.2.2.2.5 Dead Weight

The criteria for the HI-STORM UMAX System for withstanding the static loads of its components as described in Paragraph 2.3.2.5 of the main body of this FSAR apply to the loading evaluations of the HI-STORM UMAX VVM. These conditions apply to the safety evaluation of the HI-STORM UMAX VVM for all stored canisters types, including the 24PT1-DSC. When applying these conditions to the 24PT1-DSC, the components in the licensing drawings in Section I.1.5 shall be considered.

I.2.2.2.6 Handling Loads

The criteria for the HI-STORM UMAX System for withstanding loads during handling as described in Section 2.3.2.6 of the main body of this FSAR apply to the safety evaluation of the HI-STORM UMAX VVM for all the stored canisters, including the 24PT1-DSC. When demonstrating structural compliance, the design of the Canister Handling Apparatus (CHA) introduced in Supplement I.1 and illustrated in the licensing drawing package in Section I.1.5 is considered.

I.2.2.2.7 Sustained Wind Conditions

The criteria for the HI-STORM UMAX System for withstanding sustained wind conditions as described in Section 2.3.2.7 of the main body of this FSAR apply to the environmental loading evaluations of the HI-STORM UMAX VVM. These conditions apply to the safety evaluation of the HI-STORM UMAX VVM for all the stored canisters, including the 24PT1.

I.2.2.3 Loadings Applicable to Off-Normal Conditions of Storage

I.2.2.3.1 Pressure

The stored canister in the HI-STORM UMAX System must withstand off-normal pressure condition without exceeding its allowable stress limit. The off-normal condition for the 24PT1 canister internal design pressure bounds the cumulative effects of the maximum fill gas volume, normal environmental ambient temperatures, the maximum canister heat load, and an assumed 10% of the fuel rods and control components ruptured with 100% of the fill gas and 30% of the significant radioactive gases (e.g., H³, Kr, and Xe) released as suggested in NUREG-1536.

HOLTEC INTERNATIONAL COPYRIGHTED MATERIAL	
HI-2115090	Proposed Rev. 3.E
I.2-16	

The canister is loaded and sealed under Docket Number 72-1029, and there is no change to the contents, including helium gas, fuel rods, or their fill gas. Therefore, the only parameter relating to the pressure inside the DSC that may be different during storage in the HI-STORM UMAX System is the DSC temperature. The analyses in Supplement I.4 show that all temperatures of the DSC in the HI-STORM UMAX are bounded by those already approved in the NUHOMS module. Therefore, all maximum internal pressures in the 24PT1-DSC will be less than the design pressures presented in Table 3.1-6 of Reference [I.1.2.1].

I.2.2.3.2 Environmental Temperatures

The off-normal environmental temperatures as described in Section 2.3.3.2 of the main body of this FSAR apply to the environmental loading evaluations of the HI-STORM UMAX VVM. These conditions apply to the safety evaluation of the HI-STORM UMAX VVM for all the stored canisters, including the 24PT1-DSC.

I.2.2.3.3 Design Temperatures

In addition to the normal condition design temperatures, which apply to long-term storage and short-term operating conditions, an off-normal/accident condition temperature pursuant to the provisions of NUREG-1536 is also defined. This is the temperature which may exist during an event of limited duration.

Paragraph 2.3.3.3 and Table 2.3.7 of the main body of this FSAR provide the Design Temperatures for the standard components in the HI-STORM UMAX System. Table I.2.2.1 provides the off-normal/accident condition temperature limits for the 24PT1-DSC canister and the associated SSCs needed for loading and long term storage.

I.2.2.3.4 Seal Leakage

The 24PT1-DSC canister has been designed as a welded confinement pressure vessel with no mechanical or electrical penetrations and is tested to demonstrate that it is leak-tight in accordance with ANSI N14.5 requirements [I.2.2.3]. The canister does not contain seals or gaskets. Because the material of construction (stainless steel) is known from extensive industrial experience to lend to high integrity, high ductility and high fracture strength welds, the canister enclosure vessel welds provide a secure barrier against leakage, over its licensed life.

As stated in the NRC reviewed NUHOMS FSAR, the 24PT1-DSC canister itself has a series of barriers to ensure the confinement of radioactive materials. The cylindrical shell is fabricated from a rolled ASME stainless steel plate which is joined with full penetration welds that are 100% inspected by non-destructive examination. All top and bottom end closure welds are multiple-layer welds. This effectively eliminates any pinhole leaks which might occur in a single pass weld, since the chance of pinholes being in alignment on successive weld passes is not credible. Furthermore, the cover plates are sealed by separate, redundant closure welds. Pressure boundary welds and welders are qualified in accordance with Section IX of the ASME B&PV Code and inspected according to the appropriate articles of Section III, Division 1, Subsection

HOLTEC INTERNATIONAL COPYRIGHTED MATERIAL	
HI-2115090	Proposed Rev. 3.E
I.2-17	

NB [I.2.2.]. These criteria insure that the as-deposited weld filler metal is as sound as the parent metal of the pressure vessel.

I.2.2.3.5 Partial Blockage of VVM Air Inlets and Outlets

Pursuant to NUREG-1536, 50% of the inlet and outlet ducts are assumed to be blocked under an off-normal storage condition. The HI-STORM UMAX must withstand 50% blockage without exceeding allowable temperature and pressure limits specified for the off-normal condition.

I.1.2.2.4 Extreme Environmental Phenomena and Accident Conditions

The loadings corresponding to the extreme environmental phenomena and accident events, collectively referred to as Faulted States, are discussed as a part of load combinations.

I.2.2.4.1 Confinement Boundary Leakage

None of the postulated environmental phenomena or accident conditions, as stated in Paragraph 2.3.4.2 of the main body of this FSAR, will cause failure of the confinement boundary of the stored canister. Chapter 7 of the NUHOMS FSAR [I.1.2.1] which contains the confinement boundary design and evaluation for the 24PT1-DSC canister remains applicable to its storage in HI-STORM UMAX, and is further described in Supplement I.7. Therefore, Confinement Boundary leakage is designated as non-credible for 24PT1-DSC stored in the HI-STORM UMAX.

I.2.2.4.2 Handling Accident

The criteria for the HI-STORM UMAX System for withstanding loads during lifting/handling operations as described in Paragraph 2.3.4.3 of the main body of this FSAR apply to the safety evaluation of the HI-STORM UMAX System for all the stored canisters, including the 24PT1-DSC, during vertical lifting/handling operations. Vertical lifting and handling equipment (typically lift beams of cask transporter) are required to have built-in redundancy against uncontrolled lowering of the load.

Because the 24PT1-DSC contains no provision for attaching a lift rig, its lifting and handling will be carried out using a specially engineered Canister Handling Apparatus (CHA) which will be used to transfer the canister from its storage module to the HI-TRAC VW transfer cask and to protect it during the transfer casks upending operation. The CHA is also used to lower the canister in the "UMAX" cavity. The design of the CHA is required to meet the following criteria:

- The stresses in the CHA's primary members and welds must meet ANSI N14.6 limits
- No primary loaded member is subject to compressive stresses that may cause structural instability (viz., buckling)
- All materials of construction used in the CHA are long history of successful usage in the nuclear industry

HOLTEC INTERNATIONAL COPYRIGHTED MATERIAL	
HI-2115090	Proposed Rev. 3.E
I.2-18	

The handling operations involved for the change in orientations of the 24PT1-DSC canister during lifting/handling are described in Supplement I.9.

I.2.2.4.3 Non-Mechanistic Tip-Over

Because the HI-STORM UMAX VVM is situated underground and cannot be moved, a tip-over event is not a credible accident for this design.

I.2.2.4.4 Tornado

The pressures, wind loadings, and missiles generated by a tornado as described in Paragraph 2.3.4.5 of the main body of this FSAR of the HI-STORM UMAX system don't challenge the integrity of the canister ensconced below-grade inside the VVM cavity. Therefore, such loads are not germane to the safety evaluation of the various canister types stored and thus do not need to be re-evaluated in this supplement.

I.2.2.4.5 Short-Term Operations

Short-term operations and their safety considerations are discussed in Chapter 9 of the main body FSAR and Supplement I.9. Short-term operations system components temperature limits are provided in Table I.2.2.1.

I.2.2.4.6 100% Fuel Rod Rupture

For accident conditions, 100% failure of the fuel rods and control components is assumed. For the ruptured rods, 100% release of the fill gas from fuel rod and control component rods and 30% release of the fission gas is assumed, which is based on the guidance in NUREG-1536 [I.2.2.1]. The limiting accident pressure is established by adding additional margin to the calculated values to account for the presence of fission gases in the 24PT1-DSC cavity which might reduce the effective cover gas conductivity, and thus increase temperatures and pressures. The acceptance criterion for this condition is that the applicable Design Pressure of the canister is not exceeded.

The canister is loaded and sealed under Docket Number 72-1029, and there is no change to the contents, including helium gas, fuel rods, or their fill gas. Therefore, the only parameter relating to the pressure inside the DSC that may be different during storage in the HI-STORM UMAX System is the DSC temperature. The analyses in Supplement I.4 show that all temperatures of the DSC in the HI-STORM UMAX are bounded by those already approved in the NUHOMS module. Therefore, all maximum internal pressures in the 24PT1-DSC will be less than the design pressures presented in Table 3.1-6 of Reference [I.1.2.1].

HOLTEC INTERNATIONAL COPYRIGHTED MATERIAL	
HI-2115090	Proposed Rev. 3.E
I.2-19	

I.2.2.4.7 100% Blockage of Air Inlets and Outlets

The HI-STORM UMAX is postulated to be subject to a complete blockage of the inlet and outlet ducts. Supplement I.4 contains the appropriate thermal analysis and evaluation of this accident.

HOLTEC INTERNATIONAL COPYRIGHTED MATERIAL	
HI-2115090	Proposed Rev. 3. <u>E</u>
I.2-20	

Table I.2.2.1 [PROPRIETARY INFORMATION WITHHELD PER 10CFR2.390]

HOLTEC INTERNATIONAL COPYRIGHTED MATERIAL	
HI-2115090	Proposed Rev. 3. <u>E</u>
I.2-21	

I.2.3 STRUCTURALLY SIGNIFICANT LOAD COMBINATIONS AND ACCEPTANCE CRITERIA

The general criteria for structurally significant load combinations as described in Section 2.4 of the main body of this FSAR apply to the structural loading evaluations of the HI-STORM UMAX VVM for all the stored canisters, including the 24PT1-DSC.

I.2.3.1 Load Case 01: Dead Load plus Design Basis Explosion Pressure

The load case of overpressure due to an explosion near the HI-STORM UMAX VVM acting concurrently with the dead load of the system is analyzed for the HI-STORM UMAX containing the 24PT1-DSC canister storing spent nuclear fuel. This load case is analyzed according to the criteria listed in Subsection 2.4.1 and Table 2.4.1 of the main body of this FSAR.

The data specific to the 24PT1-DSC canister design is used in the design basis explosion evaluation contained in Supplement I.3. This data includes the licensing basis external pressure load under the accident flood condition.

I.2.3.2 Load Case 02: Design Basis Missile Loadings

The load case of a tornado and the accompanying missiles is provided in Subsection 2.4.2 and Table 2.4.1 of the main body of this FSAR. The HI-STORM UMAX System is protected from the effects of a tornado and accompanying missiles by virtue of its underground configuration. The only VVM component that warrants evaluation for the effects of a tornado-induced missile strike is the Closure Lid, which is made of a steel weldment with encased concrete. The Closure Lid has been demonstrated in Chapter 3 of the FSAR to be able to block all Design Basis Missiles (DBMs) from reaching the stored canister. Therefore, the 24PT1-DSC, like other certified canisters in this docket, will not be subject to the structural hazard posed by a DBM.

I.2.3.3 Load Case 03: Design Basis Seismic Event

The applicable design basis seismic event for the HI-STORM UMAX is the Most Severe Earthquake (MSE) described in Subparagraph 3.4.4.1.2 in the main body of this FSAR. The same earthquake and settlement is applicable to the system storing a 24PT1-DSC.

The “UMAX” VVM assembly has been qualified for the MSE and permitted long term settlement in the main body of this FSAR and first certified in Amendment 1 of the HI-STORM UMAX system. This qualification remains applicable to storage of the 24PT1-DSC canister because:

- This canister is substantially lighter in weight compared to the Design Basis canister.
- [

PROPRIETARY INFORMATION WITHHELD PER 10CFR2.390

]

Therefore, the structural integrity of the “UMAX” VVM assemblage under the seismic loading and long term settlement does not need to be re-visited in this supplement.

HOLTEC INTERNATIONAL COPYRIGHTED MATERIAL	
HI-2115090	Proposed Rev. 3.E
I.2-22	

The stresses developed in the Confinement Boundary of the canister, however, must be computed and compared with the ASME Subsection NB stress intensity limits for Level D condition as is done for other canister types in the main body of the FSAR. This evaluation is documented in Supplement I.3.

I.2.3.4 Load Case 04: Design Basis Handling and Impact Events

As the HI-STORM UMAX VVM is situated underground and cannot be moved, drop and tip-over events are not credible accidents for this design. The Closure Lid cannot strike the canister lid in the wake of an accidental drop event due to geometry constraints. Further, because the load handling device and lifting equipment are required to meet the defense-in-depth criteria set down in this FSAR, the drop of the Closure Lid, HI-TRAC transfer cask, Canister Handling Apparatus (with or without the 24PT1-DSC canister), or Top Seismic Restraint Assembly during handling operation is termed non-credible. The CHA is defined as a special lifting device in accordance with ANSI N14.6, qualified for a bounding load that exceeds the DSC design weight in Table I.3.2.1. Lifting and handling devices shall be designed and qualified in accordance with Supplement I.3 to accommodate handling of horizontally oriented HI-TRAC during transfer of a 24PT1-DSC canister from its host storage overpack to the HI-TRAC. Uncontrolled lowering of the horizontally oriented HI-TRAC cask is therefore termed non-credible. The assessment for the design basis handling of the loaded 24PT1-DSC is contained in Supplement I.3.

The load case of a design basis handling and impact event is defined as Load Case 04 and is discussed in Subsection 2.4.4 and Table 2.4.1 of the main body of this FSAR for the HI-TRAC and VVM Closure Lid. The assessment for the design basis handling load of the lid is applicable to the HI-STORM UMAX System for all of the stored canisters, including the 24PT1-DSC.

I.2.3.5 Load Case 05: Design Basis Fire Event

The criteria and approach for the evaluation of the design basis fire for the HI-STORM UMAX System are provided in Subsection 2.4.5 of the main body of this FSAR.

This criteria and approach are applicable to the HI-STORM UMAX System for all the stored canisters, including the 24PT1-DSC. The design basis fire event analysis for the HI-STORM UMAX containing the 24PT1-DSC is provided in Supplement I.4.

I.2.3.6 Load Case 06: Live Load on VVM During Canister Transfer

The criteria and approach for the evaluation of the live load evaluation for the HI-STORM UMAX System are provided in Subsection 2.4.6 of the main body of this FSAR. The safety evaluation for the live load on the HI-STORM UMAX ISFSI pad bounds that for 24PT1-DSC because the canister weighs far less than the design basis canister weight used in the qualification of the reinforced concrete structure that comprises the HI-STORM UMAX Storage System.

I.2.3.7 Load Case 07: Design Basis Flood

The criteria and approach for the evaluation of the design basis flood for the HI-STORM UMAX System are provided in Subsection 2.4.7 of the main body of this FSAR. The Design Basis Flood

HOLTEC INTERNATIONAL COPYRIGHTED MATERIAL	
HI-2115090	Proposed Rev. 3.E
I.2-23	

has been shown in the main body of this FSAR to produce no limit condition for any of the canister certified for the “UMAX” system. Because the safety analyses for flood are canister-independent, the safety case of 24PT1-DSC is covered by the analyses previously documented in this FSAR.

HOLTEC INTERNATIONAL COPYRIGHTED MATERIAL	
HI-2115090	Proposed Rev. 3. <u>E</u>
I.2-24	

I.2.4 THERMALLY SIGNIFICANT LOADS AND ACCEPTANCE CRITERIA

As described in Section 2.5 of the FSAR main body, the thermal design and operation of the HI-STORM UMAX System shall meet the intent of the review guidance contained in ISG-11, Revision 3. Specifically, the ISG-11 provisions that are explicitly invoked and satisfied are:

- a. The thermal acceptance criteria for all commercial spent fuel (CSF) authorized by the USNRC for operation in a commercial reactor are unified into one set of requirements.
- b. The maximum value of the calculated temperature for all CSF under long-term normal conditions of storage must remain below 400°C (752°F). For short-term operations, including canister drying, helium backfill, and on-site cask transport operations, the fuel cladding temperature must not exceed 400°C (752°F) for high burn-up fuel (HBF) and 570°C (1058°F) for moderate burn-up fuel. (HBF temperature criteria included for completeness, although the 24PT1-DSC approved contents do not include HBF.)
- c. The maximum fuel cladding temperature as a result of an off-normal or accident event must not exceed 570°C (1058°F).
- d. For HBF, operating restrictions are imposed to limit the maximum temperature excursion during short-term operations to 65°C (117°F) and the number of excursions to less than 10. (This criteria included for completeness, although the 24PT1-DSC approved contents do not include HBF.)

In Chapter I.4, the above thermal acceptance criteria are shown to be met by the 24PT1-DSC canister containing spent nuclear fuel during its storage in the UMAX System.

As stated in Supplement I.1, the 24PT1-DSC canister designated for storage in the HI-STORM UMAX system has been previously certified for the storage of spent nuclear fuel under Docket 72-1029. For storage of the 24PT1-DSC in the HI-STORM UMAX, the design basis heat load approved by the NRC (Docket 72-1029) and provided in Table I.2.1.2 is applicable.

The design temperatures for the 24PT1-DSC canister components are provided in this Supplement in Table I.2.2.1 for various conditions. The remaining values listed in Table 2.3.7 of the main body FSAR, including the design temperatures for the HI-TRAC transfer cask components and the HI-STORM UMAX VVM components, remain applicable to the thermal analyses of the HI-STORM UMAX System storing spent fuel in the 24PT1-DSC canister.

The internal pressure in the 24PT1-DSC cavity shall not exceed the normal, off-normal and accident condition pressure limits in Table 3.1-6 of [I.1.2.1] under the respective conditions.

The thermal loading conditions, as described in Section 2.5 of the main body FSAR apply to the HI-STORM UMAX system for the storage of all canisters storing spent fuel, including the 24PT1-DSC canister. The safety analyses for thermal loadings for the HI-STORM UMAX containing the 24PT1-DSC canister containing spent fuel are provided in Supplement I.4.

HOLTEC INTERNATIONAL COPYRIGHTED MATERIAL	
HI-2115090	Proposed Rev. 3.E
I.2-25	

I.2.5 MATERIALS, CODES, STANDARDS, AND PRACTICES TO ENSURE REGULATORY COMPLIANCE

The applicable codes and requirements for the design, analysis, shop manufacturing, and field erection of the HI-STORM UMAX VVMs are described in Section 2.6 of the main body of this FSAR and are unchanged by the storage of the 24PT1-DSC canister loaded with spent fuel. This includes the applicable reference codes for the reinforced concrete used to construct components of the HI-STORM UMAX System.

Section III Subsection NB of the ASME Boiler and Pressure Vessel Code [I.2.2.2], is the governing code for the structural design of the 24PT1-DSC canister. The alternatives to the ASME Code, Section III Subsection NB, applicable to the 24PT1-DSC canister in Docket Nos. 72-1029 are also applicable to the canister in the HI-STORM UMAX System, as documented in Table I.2.5.1.

Section III Subsections NG and NF of the ASME Boiler and Pressure Vessel Code [I.2.2.2], is the governing code for the structural design of the canister basket. The alternatives to the ASME Code, Section III Subsections NG and NF, applicable to the 24PT1 canister in Docket Nos. 72-1029 are also applicable to the canister in the HI-STORM UMAX System, as documented in Table I.2.5.2.

As the 24PT1-DSC canister has been previously certified and manufactured to 10CFR72 specifications, the only requirement invoked in this safety analysis is to ensure that the stress limits in the canister's pressure boundary meet the ASME Section III NB limits for the various service conditions.

Section III Subsection NF Class 3 of the ASME Code [I.2.2.2] is the applicable code to demonstrate stress compliance for the metallic structural components of the ancillaries such as the Canister Handling Apparatus. Manufacturing requirements are set down in licensing and design drawings for the ancillaries and components unique to the 24PT1-DSC canister.

As stated in the main body of the FSAR, the aggregate of the citations from the codes, standards, and generally recognized industry publications invoked in this FSAR, supplemented by the commitments in Holtec's quality assurance procedures, provide the necessary technical framework to ensure that the as-installed VVM s would meet the intent of §72.24(c), §72.120(a) and §72.236(b).

As mandated by § 72.24(c)(3) and § 72.44(d), Holtec International's quality assurance program requires all constituent parts of an SSC subject to NRC's certification under 10CFR72 to be assigned an ITS category appropriate to its function in the control and confinement of radiation. The ITS designations for the constituent parts of the HI-STORM UMAX VVM, using the guidelines of NUREG-CR/6407 [I.2.5.1], are provided in Table 2.6.2 of the main body of this FSAR. For other UMAX components used during storage operations involving the 24PT1-DSC, specifically CHA, TSRA, VVM pedestal, and DSA, the ITS designations are provided in Tables I.2.5.3 – I.2.5.5.

HOLTEC INTERNATIONAL COPYRIGHTED MATERIAL	
HI-2115090	Proposed Rev. 3.E
I.2-26	

Table I.2.5.1: 24PT1 Shell Assembly Alternatives to ASME Code, Subsection NB

Reference ASME Code Section/Article	Code Requirement	Alternative, Justification, & Compensatory Measures
NCA	All	Not compliant with NCA.
NB-1100	Requirements for Code Stamping of Components	The canister shell is designed & fabricated in accordance with the ASME Code, Section III, Subsection NB to the maximum extent practical. However, Code Stamping is not required. As Code Stamping is not required, the fabricator is not required to hold an ASME “N” or “NPT” stamp, or to be ASME Certified.
NB-2130 NB-4121	Material must be supplied by ASME approved material suppliers Material Certification by Certificate Holder	All materials designated as ASME on the FSAR drawings ⁽¹⁾ are obtained from ASME approved MM or MS supplier(s) with ASME CMTR’s. Material is certified to meet all ASME Code criteria but is not eligible for certification or Code Stamping if a non-ASME fabricator is used. As the fabricator is not required to be ASME certified, material certification to NB-2130 is not possible. Material traceability & certification are maintained in accordance with TN’s NRC approved QA program.
NB-6111	All completed pressure retaining systems shall be pressure tested	The shield plug support ring and vent and siphon block are not pressure tested due to the manufacturing sequence. The support ring is not a pressure-retaining item and the siphon block weld is helium leak tested after fuel is loaded and the inner top closure plate installed in accordance with Code Case N-595-1.
NB-7000	Overpressure Protection	No overpressure protection is provided for the canister. The function of the canister is to contain radioactive materials under normal, off-normal and hypothetical accident conditions postulated to occur during transportation and storage. The canister is designed to withstand the maximum internal pressure considering 100% fuel rod failure at maximum accident temperature. The canister is pressure tested to 120% of normal operating design pressure. An overpressure protection report is not prepared for the canister.
NB-8000	Requirements for nameplates, stamping & reports per NCA-8000	The canister nameplate provides the information required by 10 <i>CFR Part 71</i> , 49 <i>CFR Part 173</i> and 10 <i>CFR Part 72</i> as appropriate. Code stamping is not required for the canister. In lieu of code stamping, QA Data packages are prepared in accordance with the requirements of 10 <i>CFR Part 71</i> , 10 <i>CFR Part 72</i> and TN’s approved QA program.

(1) Advanced Standardized NUHOMS FSAR [I.1.2.1] and CoC (USNRC Docket 72-1029)

HOLTEC INTERNATIONAL COPYRIGHTED MATERIAL	
HI-2115090	Proposed Rev. 3.E
I.2-27	

Table I.2.5.2: 24PT1 Basket Alternatives to ASME Code, Subsection NG/NF

Reference ASME Code Section/Article	Code Requirement	Alternative, Justification, & Compensatory Measures
NCA	All	Not compliant with NCA.
NG/NF-1100	Requirements for Code Stamping of Components	The canister baskets are designed & fabricated in accordance with the ASME Code, Section III, Subsection NG/NF to the maximum extent practical. However, Code Stamping is not required. As Code Stamping is not required, the fabricator is not required to hold an ASME “N” or “NPT” stamp, or to be ASME Certified.
NG/NF-2130 NG/NF-4121	Material must be supplied by ASME approved material suppliers Material Certification by Certificate Holder	All materials designated as ASME on the FSAR drawings ⁽¹⁾ are obtained from ASME approved MM or MS supplier(s) with ASME CMTR’s. Material is certified to meet all ASME Code criteria but is not eligible for certification or Code Stamping if a non-ASME fabricator is used. As the fabricator is not required to be ASME certified, material certification to NG/NF-2130 is not possible. Material traceability & certification are maintained in accordance with TN’s NRC approved QA program.
Table NG-3352-1	Permissible Joint Efficiency Factors	Joint efficiency (quality) factor of 1 is assumed for the guidesleeve longitudinal weld. Table NG-3352-1 permits a quality factor of 0.5 for full penetration weld with visual inspection. Inspection of both faces provides $n = (2*0.5) = 1$. This is justified by this gauge of material (0.12 inch) with visual examination of both surfaces which ensures that any significant deficiencies would be observed and corrected.
NG/NF-8000	Requirements for nameplates, stamping & reports per NCA-8000	The canister nameplate provides the information required by 10 <i>CFR Part 71</i> , 49 <i>CFR Part 173</i> and 10 <i>CFR Part 72</i> as appropriate. Code stamping is not required for the canister. In lieu of code stamping, QA Data packages are prepared in accordance with the requirements of 10 <i>CFR Part 71</i> , 10 <i>CFR Part 72</i> and TN’s approved QA program.
N/A	N/A	Oversleeve to guidesleeve welds are non-code welds which meet the requirements of AWS D1.3-98, the Structural Welding Code-Sheet Steel.

(1) Advanced Standardized NUHOMS FSAR [I.1.2.1] and CoC (USNRC Docket 72-1029).

HOLTEC INTERNATIONAL COPYRIGHTED MATERIAL	
HI-2115090	Proposed Rev. 3.E
I.2-28	

Table I.2.5.3 [PROPRIETARY INFORMATION WITHHELD PER 10CFR2.390]

HOLTEC INTERNATIONAL COPYRIGHTED MATERIAL	
HI-2115090	Proposed Rev. 3. <u>E</u>
I.2-29	

Table I.2.5.4 [PROPRIETARY INFORMATION WITHHELD PER 10CFR2.390]

HOLTEC INTERNATIONAL COPYRIGHTED MATERIAL	
HI-2115090	Proposed Rev. 3. <u>E</u>
I.2-30	

Table I.2.5.5 [PROPRIETARY INFORMATION WITHHELD PER 10CFR2.390]

HOLTEC INTERNATIONAL COPYRIGHTED MATERIAL	
HI-2115090	Proposed Rev. 3. <u>E</u>
I.2-31	

I.2.6 SAFETY PROTECTION SYSTEMS

I.2.6.1 General

The general criteria for the safety systems of the HI-STORM UMAX VVM, as described in Section 2.7 of the main body of this FSAR are unchanged by the storage of spent fuel in the 24PT1 canister within the VVM. The HI-STORM UMAX, with all stored canisters, will withstand all normal, off-normal, and postulated accident conditions without release of radioactive material or excessive radiation exposure to workers or members of the public.

I.2.6.2 Protection by Multiple Confinement Barriers and Systems

The confinement of the spent fuel is provided by the 24PT1-DSC canister.

The 24PT1-DSC canister is loaded with spent fuel under the Docket 72-1029 CoC as described in the Standardized Advanced NUHOMS FSAR [2.0.1]. The procedure for ensuring the integrity of the confinement barriers during fuel loading are described in Chapter 7 of this FSAR and the criteria for the protection by confinement barriers and systems is described in Section 2.3.

The spent nuclear fuel is confined by the 24PT1-DSC canister shell and the top and bottom cover plates. The fuel cladding integrity is ensured by maintaining the storage cladding temperatures below levels which may compromise cladding integrity. In addition, the spent fuel assemblies are stored in an inert atmosphere to prevent degradation of the cladding, specifically cladding rupture due to oxidation and its resulting volumetric expansion of the fuel. The helium atmosphere for the 24PT1-DSC incorporated in the design protects the fuel cladding integrity by inhibiting the ingress of oxygen into the cavity.

Helium is known to leak through valves, mechanical seals, and escape through very small passages because it has extremely high fugacity, is an inert element, and exists in a monatomic species. Helium will not, to any practical extent, diffuse through stainless steel. For this reason the 24PT1-DSC canister has been designed as a welded confinement pressure vessel with no mechanical or electrical penetrations and is tested to demonstrate that it is leak-tight. Supplement I.7 discusses the confinement boundary design.

The 24PT1-DSC canister itself has a series of barriers to ensure the confinement of radioactive materials. The cylindrical shell is fabricated from rolled ASME stainless steel plate which is joined with full penetration welds that are 100% inspected by non-destructive examination. All top and bottom end closure welds are multiple-layer welds. This effectively eliminates any pinhole leaks which might occur in a single pass weld, since the chance of pinholes being in alignment on successive weld passes is not credible. Furthermore, the cover plates are sealed by separate, redundant closure welds.

Pressure monitoring instrumentation is not used since penetration of the pressure boundary would be required. The penetration itself would then become a potential leakage path and by its presence compromise the integrity of the 24PT1-DSC canister design. The shell and welded cover plates provide total confinement of radioactive materials. Once the 24PT1-DSC canister is sealed, there are no credible events, as discussed in Supplement I.11, which could cause the failure of the cylindrical shell or the closure plates which form the confinement boundary.

HOLTEC INTERNATIONAL COPYRIGHTED MATERIAL	
HI-2115090	Proposed Rev. 3.E
I.2-32	

I.2.6.3 Protection by Equipment and Instrumentation Selection

The criteria for protection by equipment and instrumentation selection for the HI-STORM UMAX System as described in Section 2.7.3 of the main body of this FSAR apply to the safety evaluation of the HI-STORM UMAX System for all the stored canisters, including the 24PT1-DSC.

The only modification to the criteria provided in Section 2.7.3 is that the 24PT1-DSC canister requires a change in orientation from its original horizontal storage configuration in the Standardized Advanced NUHOMS System to the vertical storage configuration in the HI-STORM UMAX. The handling operations, including any special equipment, involved for the change in orientation of the 24PT1-DSC canister are described in Supplement I.9.

HOLTEC INTERNATIONAL COPYRIGHTED MATERIAL	
HI-2115090	Proposed Rev. 3. <u>E</u>
I.2-33	

I.2.7 NUCLEAR CRITICALITY SAFETY

The design criteria for criticality is that the effective neutron multiplication factor, k_e , including statistical uncertainties and bias, shall be less than 0.95 for all postulated arrangements of fuel within the canister.

I.2.7.1 Control Methods for Prevention of Criticality

The control methods and design features used to prevent criticality for all 24PT1-DSC canister configurations are the following:

- Favorable geometry provided by the canister fuel basket structural components that maintain the relative position of the spent fuel assemblies under all normal, off-normal, and accident conditions.
- A sufficiently high fuel basket neutron absorber (B-10) concentration leads to a lower reactivity level under all operating scenarios.

All appropriate criticality analyses are presented in Chapter 6 of the Standardized Advanced NUHOMS FSAR [I.1.2.1]. The storage of 24PT1-DSC canister in the HI-STORM UMAX system presents no new reactivity modification scenario that would warrant evaluation in this supplement.

I.2.7.2 Error Contingency Criteria

Provision for error contingency is built into the criticality analyses performed in Chapter 6 of the Standardized Advanced NUHOMS FSAR [I.1.2.1]. Because biases and uncertainties are explicitly evaluated in the analysis, it is not necessary to introduce additional contingency for error, as previously accepted by the NRC in docket number 72-1029.

I.2.7.3 Verification Analyses

In Section 6.5 of the Standardized Advanced NUHOMS FSAR [I.1.2.1], critical benchmark experiments are selected which reflect the design configurations. These critical experiments are evaluated using the same calculation methods, and a suitable bias is incorporated in the reactivity calculation. The USNRC has previously accepted these verification analyses perform to certify the 24PT1-DSC canister for storage under the provisions of 10CFR72.

HOLTEC INTERNATIONAL COPYRIGHTED MATERIAL	
HI-2115090	Proposed Rev. 3.E
I.2-34	

I.2.8 RADIOLOGICAL PROTECTION

The provisions for radiological protection of the HI-STORM UMAX System are described in Section 2.9 of the main body of this FSAR which are also applicable to the storage of spent fuel in the 24PT1-DSC canister. This includes the design of the access control systems as well as the shielding design of the HI-STORM UMAX System.

Details of the radiological protection program for the HI-STORM UMAX System are discussed in Chapter 11 of the main body FSAR and Chapter I.11 of this Supplement.

I.2.9 FIRE AND EXPLOSION PROTECTION

There are no combustible or explosive materials associated with the HI-STORM UMAX System. Combustible materials will not be stored within the HI-STORM UMAX ISFSI. However, for conservatism, a hypothetical fire accident has been analyzed in Chapter 4 of the main body of the FSAR as a bounding condition for HI-STORM UMAX System. The evaluation of the HI-STORM UMAX System with a 24PT1-DSC fire accident is discussed in Chapter I.12.

Explosive material will not be stored within an ISFSI. Small overpressures may result from accidents involving explosive materials which are stored or transported in the vicinity of the site. Explosion as an accident loading condition has been considered in Chapter 12 of the main body FSAR.

I.2.10 DECOMMISSIONING CONSIDERATIONS

The considerations for the decommissioning of the ISFSI containing the HI-STORM UMAX System are described in Section 2.11 of the main body of this FSAR and are unchanged for the VVM and associated components.

The 24PT1-DSC canister is designed to interface with a 10CFR 71 transportation system for the eventual off-site transport of canisters by the DOE to either a monitored retrievable storage facility (MRS) or a permanent geologic repository. The 24PT1-DSC canister is compatible with wet or dry unloading facilities.

The exact decommissioning plan for the ISFSI will be dependent on the DOE's fuel transportation system capability and requirements. Because of the minimal contamination of the outer surface of the 24PT1-DSC canister, no contamination is expected on the internal surfaces of the VVM.

I.2.11 REGULATORY COMPLIANCE

The justification of regulatory compliance of the HI-STORM UMAX System are described in Section 2.12 of the main body of this FSAR and the Standardized Advanced NUHOMS FSAR [I.1.2.1], the 24PT1-DSC canister was initially certified.

HOLTEC INTERNATIONAL COPYRIGHTED MATERIAL	
HI-2115090	Proposed Rev. 3.E
I.2-35	

I.2.12 REFERENCES

- [I.2.0.1] Intentionally Not Used
- [I.2.0.2] The American Society of Mechanical Engineers, Boiler and Pressure Vessel Code, 2010 Edition, Section III, Division 1 - Subsection NF, "Rules for Construction of Nuclear Facility Components", New York, New York.
- [I.2.0.3] U.S. Nuclear Regulatory Commission, "Final Safety Evaluation Report Transnuclear, Inc. Standardized Advanced NUHOMS Horizontal Modular Storage System for Irradiated Nuclear Fuel", Amendment No. 3, Docket 72-1029, February 20, 2015.
- [I.2.0.4] U.S. Nuclear Regulatory Commission, "Certificate of Compliance for Radioactive Material Packages," Revision 8, NUHOMS MP187 Multipurpose Cask Transportation Package, Docket 71-9255, October 18, 2002.
- [I.2.0.5] U.S. Nuclear Regulatory Commission, "Cladding Considerations for the Transport and Storage of Spent Fuel," ISG-11, Revision 3, Washington, DC, November 17, 2003.
- [I.2.1.1] Office of Civilian Radioactive Waste Management (U.S. Department of Energy), "Topical Report on Actinide-Only Burnup Credit for PWR Spent Nuclear Fuel Packages," DOE/RW-0472, Revision 2, September 1998.
- [I.2.1.2] Energy Information Administration (U.S. Department of Energy), "Spent Nuclear Fuel Discharges from U.S. Reactors," Page 23, SR/CNEAF/95-01, Washington, DC, February 1995.
- [I.2.1.3] U.S. Nuclear Regulatory Commission, "Connecticut Yankee Atomic Power Company; Haddam Neck Plant; Environmental Assessment and Finding of No Significant Impact," Federal Register Notice, Vol. 67, No. 213, November 4, 2002, pp. 67212 - 67218.
- [I.2.2.1] U.S. Nuclear Regulatory Commission, "Standard Review Plan for Dry Cask Storage Systems," NUREG-1536, January 1997.
- [I.2.2.2] The American Society of Mechanical Engineers, Boiler & Pressure Vessel Code, 1992 Edition, Section III, Division 1 - Subsections NB, NF and NG, "Rules for Construction of Nuclear Facility Components," Addenda through 1994 with Code Case N-595-1, New York, New York.
- [I.2.2.3] American National Standards Institute, "American National Standard for Radioactive Materials – Leakage Tests on Packages for Shipment", ANSI N14.5-1997, New York, New York.
- [I.2.2.4] The American Society of Mechanical Engineers, Boiler & Pressure Vessel Code, 2007 Edition, Section III, Division 1 - Subsections NB, NF, and NG. "Rules for Construction of Nuclear Facility Components" New York, New York.

HOLTEC INTERNATIONAL COPYRIGHTED MATERIAL	
HI-2115090	Proposed Rev. 3.E
I.2-36	

[I.2.5.1] U.S. Nuclear Regulatory Commission, "Classification of Transportation Packaging and Dry Spent Fuel Storage System Components According to Importance to Safety," NUREG/CR-6407, February 1996.

HOLTEC INTERNATIONAL COPYRIGHTED MATERIAL	
HI-2115090	Proposed Rev. 3.E
I.2-37	

SUPPLEMENT I.3: STRUCTURAL EVALUATION

I.3.0 OVERVIEW

In this supplement, the structural adequacy of 24PT1-DSC for storage within the HI-STORM UMAX VVM is evaluated pursuant to the guidelines of NUREG-1536.

The organization of technical information in this supplement mirrors the format and content of Chapter 3 except that it only contains material directly pertinent to storage of the 24PT1-DSC canister, which is further described in Paragraph I.1.2.1.1.

Since the 24PT1-DSC canister has already been approved by the NRC for storage under Part 72, (and is presently in active use) under Docket No. 72-1029, much of the safety analysis information is incorporated herein by reference to the NUHOMS FSAR [I.1.2.1]. For clarity, Table I.3.0.1 below identifies the information incorporated by reference, the source of the information, a reference to the NRC approval of the information (SER), where in this supplement it is incorporated, and a discussion of the applicability of the previously approved information.

Section I.1.5 contains the Licensing Drawings for UMAX system components specific to transfer and storage of the 24PT1-DSC. Licensing Drawings for generic system components (VVM and HI-TRAC) utilized during storage of all authorized canisters are provided in Section 1.5 of this FSAR.

The applicable codes, standards, and practices governing the structural analysis of the 24PT1-DSC canister within the HI-STORM UMAX VVM, as well as the design criteria, are presented in Supplement I.2. Throughout this supplement, the term “*safety factor*” is defined as the *ratio of the allowable stress (load) or displacement for the applicable load combination to the maximum computed stress (load) or displacement*. Where applicable, bounding safety factors are computed using values that bound the calculated results.

HOLTEC INTERNATIONAL COPYRIGHTED MATERIAL	
HI-2115090	Proposed Rev. 3.I
I.3-1	

Table I.3.0.1: Material Incorporated by Reference

Information Incorporated by Reference	Source of the Information	NRC Approval of Material Incorporated by Reference	Location in this FSAR where Material is Incorporated	Technical Justification of Applicability to HI-STORM UMAX
Design Basis Canister Deceleration Under Accident Conditions	Standardized Advanced NUHOMS FSAR Section 3.1.2.1.3.5 [I.1.2.1]	Standardized Advanced NUHOMS SER, Amendment 0, Reference [I.2.0.3]	Table I.3.1.1	The canister is analyzed in the NUHOMS FSAR for a vertical end drop and a horizontal side drop, which produce peak impact decelerations on canister. Bounding decelerations are statically applied to the canister and its internals to demonstrate compliance with governing stress limits. Storage within the HI-STORM UMAX will not affect the canister's inherent design strength.
Canister Design Weight	Standardized Advanced NUHOMS FSAR Table 1.2-1 [I.1.2.1]	Standardized Advanced NUHOMS SER, Amendment 0, Reference [I.2.0.3]	Table I.3.2.1	The canister is loaded and sealed under the NUHOMS CoC (NRC Docket 72-1029) following the design criteria and analyses described in the NUHOMS FSAR. Storage within the HI-STORM UMAX will not affect the design weight of the canister.
External Pressure Load Due to Flood Accident	Standardized Advanced NUHOMS FSAR Table 3.1-7 [I.1.2.1]	Standardized Advanced NUHOMS SER, Amendment 0, Reference [I.2.0.3]	Subparagraph I.3.4.4.1.9	The canister is analyzed in the NUHOMS FSAR under a flood accident resulting in an external pressure load. Storage within the HI-STORM UMAX will not affect the canister's capacity to resist accident external pressure loads.
<u>Fuel Rod Integrity Evaluation</u>	<u>Standardized Advanced NUHOMS FSAR Section 3.5.3 [I.1.2.1]</u>	<u>Standardized Advanced NUHOMS SER, Amendment 0, Reference [I.2.0.3]</u>	<u>Table I.3.1.1</u>	<u>The stored fuel rods inside the canister are analyzed in the NUHOMS FSAR for a side impact load and corner impact load, which produce axial and lateral decelerations on the fuel rod cladding. Under axial load, the fuel rod is</u>

HOLTEC INTERNATIONAL COPYRIGHTED MATERIAL

HI-2115090

Proposed Rev. 3.I

I.3-2

				<p><u>analyzed as a slender column with pinned ends. Under lateral load, the fuel rod is analyzed as a clamped beam with a span length equal to the unsupported length between grid straps. Storage within the HI-STORM UMAX will not affect the fuel rods' inherent strength or buckling capacity.</u></p>
--	--	--	--	---

HOLTEC INTERNATIONAL COPYRIGHTED MATERIAL	
HI-2115090	Proposed Rev. 3.I
I.3-3	

I.3.1 STRUCTURAL DESIGN

I.3.1.1 Discussion

As shown in Supplement I.2, the safety evaluation for the storage of the 24PT1-DSC ("the Canister") in the HI-STORM UMAX VVM reduces to the determination of its response to the Design Basis Earthquake, which has been set down as the Most Severe Earthquake (MSE) (see Table 2.4.5 and Figures 2.4.7 through 2.4.11).

The only geometric modifications to the HI-STORM UMAX VVM design of structural consequence, as compared to the certified design, are:

[

PROPRIETARY INFORMATION WITHHELD PER 10CFR2.390

]

I.3.1.2 Design Criteria and Applicable Loads

The design criteria and applicable loads for the HI-STORM UMAX VVM components and ISFSI structures remain as described in Subsection 3.1.2. Similar to the MPC, the objective of the structural analysis of the 24PT1-DSC canister is to demonstrate that:

- i. Confinement of radioactive material is maintained under normal, off-normal, accident conditions, and natural phenomenon events.
- ii. The canister internals do not deform under credible loading conditions such that the subcriticality or retrievability of the SNF is jeopardized.
- iii. The structural integrity of the stored fuel rods is maintained under normal, off-normal, accident conditions, and natural phenomenon events.

HOLTEC INTERNATIONAL COPYRIGHTED MATERIAL	
HI-2115090	Proposed Rev. 3.I
I.3-4	

To ensure that the 24PT1-DSC design continues to meet the above safety goals under the MSE event, acceptance criteria for the 24PT1-DSC in Table I.3.1.1 have been provided.

Individual loads of structural significance, applicable to the 24PT1-DSC while stored in the HI-STORM UMAX VVM, are defined in Section I.2.3.

I.3.1.3 Stress Analysis Models and Computer Codes

The seismic response of the 24PT1-DSC inside the HI-STORM UMAX VVM is determined using essentially the same Design Basis Seismic Model and computer code as previously used to qualify the HI-STORM UMAX Version MSE in Chapter 3 of this FSAR. Thus, the general description and of the finite element model for the HI-STORM UMAX VVM presented in Subsection 3.1.3 remains applicable to the seismic analyses performed in this supplement. The only notable differences between the Design Basis Seismic Model in Chapter 3 and the one used herein are related to the canister type (24PT1-DSC versus MPC) and its support configuration (see Subparagraph I.3.4.4.1.2 for more details).

[
 PROPRIETARY INFORMATION WITHHELD PER 10CFR2.390
]

HOLTEC INTERNATIONAL COPYRIGHTED MATERIAL	
HI-2115090	Proposed Rev. 3.I
I.3-5	

Table I.3.1.1			
ACCEPTANCE CRITERIA FOR 24PT1-DSC FOR DEPLOYMENT IN HI-STORM UMAX			
	Item	Limiting Value	Source
1.	Maximum permissible <u>canister</u> deceleration under accident loading condition	75g (lateral) 60g (vertical)	Section 3.1.2.1.3.5 of the Advanced NUHOMS FSAR [I.1.2.1]
2.	Maximum local plastic strain in the confinement boundary shell	0.1	Reference [3.1.3]
3.	<u>Maximum permissible fuel rod deceleration under accident loading condition</u>	<u>13g (axial)</u> <u>22g (lateral)</u> <u>(see Note 1)</u>	<u>Section 3.5.3 of the Advanced NUHOMS FSAR [I.1.2.1]</u>
<u>Notes:</u>			
<u>1) Values based on 25g corner drop at 30 degree angle with respect to horizontal as described in Section 3.5.3.1.2 of the NUHOMS FSAR [I.1.2.1].</u>			

HOLTEC INTERNATIONAL COPYRIGHTED MATERIAL

HI-2115090

Proposed Rev. 3.I

I.3-6

Table I.3.1.2

PROPRIETARY INFORMATION WITHHELD PER 10CFR2.390

HOLTEC INTERNATIONAL COPYRIGHTED MATERIAL

HI-2115090

Proposed Rev. 3.I

I.3-7

I.3.2 WEIGHTS AND CENTERS OF GRAVITY

Table I.3.2.1 provides bounding weight data of the movable components (TSRA, CHA, and 24PT1-DSC) required for the structural analysis of the HI-STORM UMAX for storage of the 24PT1-DSC. It is noted that the combined weight of the CHA plus the 24PT1-DSC design weight is less than the bounding MPC weight in Table 3.2.1 of Chapter 3. Therefore, the loaded Transfer Cask weight listed in Table 3.2.1 also bounds the sum of 24PT1-DSC design weight, CHA, and HI-TRAC VW transfer cask.

Table I.3.2.2 provides the optimized height of the internal cavity and bottom-to-top external dimension of the HI-TRAC VW for use with the 24PT1-DSC.

Because the HI-STORM UMAX is immovable and is situated underground, its CG data is not germane to safety evaluation. The Closure Lid is essentially a radially symmetric structure and, as such, its center-of-gravity is closely aligned with its axis of symmetry.

HOLTEC INTERNATIONAL COPYRIGHTED MATERIAL	
HI-2115090	Proposed Rev. 3.I
I.3-8	

Table I.3.2.1	
WEIGHT DATA USED IN STRUCTURAL ANALYSES	
Item	Bounding Weight
Top Seismic Restraint Assembly (TSRA)	2,100 lb
Canister Handling Apparatus (CHA)	9,900 lb
24PT1-DSC Design Weight	82,000 lb (see Note 1)
Notes:	
1. Per Table 1.2-1 of Advanced NUHOMS FSAR [I.1.2.1].	

HOLTEC INTERNATIONAL COPYRIGHTED MATERIAL	
HI-2115090	Proposed Rev. 3.I
I.3-9	

Table I.3.2.2

PROPRIETARY INFORMATION WITHHELD PER 10CFR2.390

HOLTEC INTERNATIONAL COPYRIGHTED MATERIAL

HI-2115090

Proposed Rev. 3.I

I.3-10

I.3.3 MECHANICAL PROPERTIES OF MATERIALS

Same as in Section 3.3.

I.3.4 GENERAL STANDARDS FOR CASKS

I.3.4.1 Chemical and Galvanic Reactions

The potential of chemical and galvanic action in the HI-STORM UMAX VVM assembly is evaluated in Chapter 8 and Supplement I.8 of this FSAR.

I.3.4.2 Positive Closure

Same as in Subsection 3.4.2.

I.3.4.3 Lifting Devices

I.3.4.3.1 Identification of Lifting Devices and Required Safety Factors

The lifting devices and interfacing lift points associated with the HI-STORM UMAX VVM, including its Closure Lid, are evaluated in Section 3.4.3 of Chapter 3. Therefore, the evaluations performed in this paragraph focus on the lifting device used to handle the 24PT1-DSC and the lifting points on the Top Seismic Restraint Assembly (TSRA).

The 24PT1-DSC does not have any interfacing lift points on its exterior that directly enable lifting of the loaded canister either horizontally or vertically. Therefore, a special lifting device is required to load the 24PT1-DSC into a HI-TRAC VW transfer cask and transfer it to the HI-STORM UMAX storage cavity. [

PROPRIETARY INFORMATION WITHHELD PER 10CFR2.390

]

As required by Reg. Guide 3.61, lifting operations applicable to the TSRA are also analyzed. Because of the nature of the HI-STORM UMAX system, placement or removal of the TSRA may occur with a loaded 24PT1-DSC inside the VVM cavity. Therefore, a stress analysis of the TSRA to demonstrate compliance with NUREG-0612 to provide the assurance that a structural failure will not occur during lifting is summarized in this supplement.

All lifting analyses presented in this supplement conservatively assume that the dead load is

HOLTEC INTERNATIONAL COPYRIGHTED MATERIAL	
HI-2115090	Proposed Rev. 3.I
I.3-11	

amplified by 15% consistent with the analyses presented in Section 3.4.3 of Chapter 3.

I.3.4.3.2 Lifting Analysis of CHA Carrying a Loaded 24PT1-DSC (Load Case 04 in Section I.2.3)

The CHA is analyzed using a combination of finite-element models of components, and a strength-of-materials based approach. The three-dimensional finite-element models of the CHA components are created using ANSYS [I.3.4.1] and shown in Figure I.3.4.1. [

PROPRIETARY INFORMATION WITHHELD PER 10CFR2.390

]

Table I.3.4.1 summarizes key results obtained from the lifting analysis of the CHA carrying a loaded 24PT1-DSC for a bounding set of input design loads. It is concluded that all structural integrity requirements are met for this lifting condition. All calculated factors of safety are greater than 1.0, indicating margin over and above the ANSI N14.6 mandated safety factors of 6 and 10 with respect to yield and ultimate strength.

I.3.4.3.3 Lifting Analysis of TSRA (Load Case 04 in Section I.2.3)

The lifting analysis of the TSRA under its own self-weight is performed using a strength-of-materials based approach. [

PROPRIETARY INFORMATION WITHHELD PER 10CFR2.390

]

Table I.3.4.2 summarizes key results obtained from the lifting analysis of the TSRA. It is concluded that all structural integrity requirements are met for this lifting condition. All factors of safety are greater than 1.0.

I.3.4.4 Heat

The evaluation of the HI-STORM UMAX system under thermally significant conditions listed in Section I.2.4 is reported in Supplement I.4.

a. Summary of Pressures and Temperatures

HOLTEC INTERNATIONAL COPYRIGHTED MATERIAL	
HI-2115090	Proposed Rev. 3.I
I.3-12	

Required input data for the structural analysis of the 24PT1-DSC stored inside HI-STORM UMAX VVM assembly is contained in Tables 2.3.1, 2.3.10, I.3.1.2 and the Licensing Drawings.

b. Differential Thermal Expansion

i. Normal Hot Environment

All clearances between the 24PT1-DSC, the CHA, and the HI-STORM UMAX VVM system are considerably larger than the thermal expansion that may occur during system operations. Therefore, no interferences between these components will occur due to thermal expansion of the loaded canister. [

PROPRIETARY INFORMATION WITHHELD PER 10CFR2.390

]

Subsection I.4.4.7 addresses the differential thermal expansion of the 24PT1-DSC and its internals while stored inside the HI-STORM UMAX.

ii. Design Basis Fire Event (Load Case 05 in Section I.2.3)

The thermal analysis of the Design Basis Fire event is documented in Supplement I.4 and evaluated in Supplement I.12 for its safety consequence. It is shown in Supplement I.4 that the fire accident has a small effect on the 24PT1-DSC temperature because of blocking action of the underground storage system and the short duration of the fire event. As a result, the computed temperatures remain below the DSC-24PT1 temperature limits established in the Advanced NUHOMS FSAR [I.2.0.1]. Therefore, a structural evaluation of the 24PT1-DSC under the postulated fire event is not required for storage inside the HI-STORM UMAX.

Likewise, it is shown that the load bearing components in the HI-STORM UMAX assembly will remain well below the temperature that may induce a significant structural deformation or collapse.

I.3.4.4.1 Safety Analysis

HOLTEC INTERNATIONAL COPYRIGHTED MATERIAL	
HI-2115090	Proposed Rev. 3.I
I.3-13	

I.3.4.4.1.1 Design Basis Flood (Load Case 07 in Section I.2.3)

Unlike free standing casks, moving flood water is not an event of safety consequence to HI-STORM UMAX: The buried configuration of the HI-STORM UMAX system renders it immune from sliding (that is germane to above ground freestanding casks) under the action of a design basis flood.

I.3.4.4.1.2 Design Basis Earthquake (Load Case 03 in Section I.2.3)

The treatment of Load Case 03 (Design Basis Earthquake) for storage of the 24PT1-DSC inside the HI-STORM UMAX system, including the model and analysis methodology, is nearly identical to that which is described in Subparagraph 3.4.4.1.2 of Chapter 3 for structural qualification of the HI-STORM UMAX Version MSE. The only differences between the two models are:

[

PROPRIETARY INFORMATION WITHHELD PER 10CFR2.390

]

Structural analyses are performed for storage of the 24PT1-DSC inside the HI-STORM UMAX by using the same analysis methods as those employed in the original HI-STORM UMAX Version MSE qualification in Chapter 3. Detailed calculations are documented in [I.3.4.2]. [

HOLTEC INTERNATIONAL COPYRIGHTED MATERIAL	
HI-2115090	Proposed Rev. 3.I
I.3-14	

PROPRIETARY INFORMATION WITHHELD PER 10CFR2.390

]

The above analyses show that the 24PT1-DSC and the HI-STORM UMAX meet all of the applicable structural acceptance criteria for safe storage. In particular, it is shown that:

- a. The Canister retrievability subsequent to the MSE event is maintained with a large margin.
- b. The maximum primary stress in the 24PT1-DSC shell remains well below the Level D primary stress intensity limit for Class 1 “NB” pressure vessels.
- c. The local impact strain in the 24PT1-DSC shell is a small fraction of the local strain limit for stainless steel specified in Table I.3.1.1.
- d. The DSC Spacer Blocks and the DSC Pedestal remain functional during the MSE condition.
- e. The maximum Canister and fuel rod decelerations are significantly less than the acceptable values listed in Table I.3.1.1.
- f. The structural strength of the ISFSI slab (Table 2.4.3) is not exceeded.

I.3.4.4.1.3 Design Basis Missile Loading (Load Case 02 in Section I.2.3)

HOLTEC INTERNATIONAL COPYRIGHTED MATERIAL	
HI-2115090	Proposed Rev. 3.I
I.3-15	

Same as in Subparagraph 3.4.4.1.3.

I.3.4.4.1.4 Non-Mechanistic Tipover

Tipover is not an applicable load case for HI-STORM UMAX. The VVM is situated underground and cannot be moved; therefore, drop and tipover events are not credible accidents for this design configuration.

I.3.4.4.1.5 Maximum Temperature and Internal Pressure under Normal and Off-Normal Conditions

The HI-STORM UMAX VVM is open to the environment; therefore, it is not subject to any internal pressure.

The 24PT1-DSC has been analyzed and qualified for normal and off-normal conditions of storage in its host docket (i.e., docket number 72-1029 for Advanced NUHOMS). Calculations in Supplement I.4 show that the internal operating temperature in the 24PT1-DSC at its permissible maximum heat load when stored in HI-STORM UMAX is less than the value used in the stress analysis in docket number 72-1029. Because the internal pressure in the 24PT1-DSC bears a proportional relationship to the average internal temperature in the Canister cavity, it follows that the internal pressure in the 24PT1-DSC when stored in HI-STORM UMAX will be less than that assumed in the stress analysis of the 24PT1-DSC in docket number 72-1029. Therefore, the stress values computed for the 24PT1-DSC under normal and off normal operating conditions in docket number 72-1029 will envelope their corresponding values for storage in HI-STORM UMAX.

I.3.4.4.1.6 Maximum Temperature and Internal Pressure Under Accident Conditions

HI-STORM UMAX, being an open to environment cask, does not experience any internal pressure under accident conditions.

The 24PT1-DSC has been analyzed and qualified for accident conditions of storage in its host docket (i.e., docket number 72-1029 for Advanced NUHOMS). Calculations in Supplement I.4 show that the internal operating temperature in the 24PT1-DSC at its permissible maximum heat load when stored in HI-STORM UMAX is less than the value used in the stress analysis in docket number 72-1029. Because the internal pressure in the 24PT1-DSC bears a proportional relationship to the average internal temperature in the Canister cavity, it follows that the internal pressure in the 24PT1-DSC when stored in HI-STORM UMAX will be less than that assumed in the stress analysis of the 24PT1-DSC in docket number 72-1029. Therefore, the stress values computed for the 24PT1-DSC under accident conditions in docket number 72-1029 will envelope their corresponding values for storage in HI-STORM UMAX.

I.3.4.4.1.7 Handling of Components

HOLTEC INTERNATIONAL COPYRIGHTED MATERIAL	
HI-2115090	Proposed Rev. 3.I
I.3-16	

The stress analyses of the HI-STORM UMAX VVM under normal handling conditions are presented in Subsection 3.4.3. The stress analyses of the CHA carrying a loaded 24PT1-DSC and the TSRA under normal handling conditions are presented in Subsection I.3.4.3 of this supplement.

I.3.4.4.1.8 **Transfer Cask and Mating Device Loading on VVM Container Shell**
(Load Case 06 in Section I.2.3)

The analysis presented in Subparagraph 3.4.4.1.9 remains valid as the combined maximum weight of the HI-TRAC VW transfer cask carrying a loaded 24PT1-DSC plus the Canister Handling Apparatus is less than the bounding weight considered in Subparagraph 3.4.4.1.9.

I.3.4.4.1.9 **Dead Load plus Design Basis Explosion Pressure on VVM Components (Load Case 01 in Section I.2.3)**

Same as in Subparagraph 3.4.4.1.10. For the 24PT1-DSC, the licensing basis external pressure load under the accident flood condition, as given in Table 3.1-7 of [I.1.2.1], bounds the explosive overpressure defined in Table 2.3.1.

I.3.4.4.1.10 **Design Basis Fire on VVM Closure Lid (Load Case 05 in Section I.2.3)**

Same as in Subparagraph 3.4.4.1.11.

I.3.4.5 **Cold**

Same as in Subsection 3.4.5 of the main body of this FSAR.

I.3.4.6 **Miscellaneous Evaluations**

None.

I.3.4.7 **Service Life of HI-STORM UMAX VVM**

Same as in Subsection 3.4.7 of the main body of this FSAR.

HOLTEC INTERNATIONAL COPYRIGHTED MATERIAL	
HI-2115090	Proposed Rev. 3.I
I.3-17	

Table I.3.4.1

PROPRIETARY INFORMATION WITHHELD PER 10CFR2.390

HOLTEC INTERNATIONAL COPYRIGHTED MATERIAL

HI-2115090

Proposed Rev. 3.I

I.3-18

Table I.3.4.2

PROPRIETARY INFORMATION WITHHELD PER 10CFR2.390

HOLTEC INTERNATIONAL COPYRIGHTED MATERIAL

HI-2115090

Proposed Rev. 3.I

I.3-19

Table I.3.4.3

PROPRIETARY INFORMATION WITHHELD PER 10CFR2.390

HOLTEC INTERNATIONAL COPYRIGHTED MATERIAL

HI-2115090

Proposed Rev. 3.I

I.3-20

Table I.3.4.3 (continued)

PROPRIETARY INFORMATION WITHHELD PER 10CFR2.390

HOLTEC INTERNATIONAL COPYRIGHTED MATERIAL

HI-2115090

Proposed Rev. 3.I

I.3-21

Table I.3.4.4

PROPRIETARY INFORMATION WITHHELD PER 10CFR2.390

HOLTEC INTERNATIONAL COPYRIGHTED MATERIAL

HI-2115090

Proposed Rev. 3.I

I.3-22

Table I.3.4.4 (continued)

PROPRIETARY INFORMATION WITHHELD PER 10CFR2.390

HOLTEC INTERNATIONAL COPYRIGHTED MATERIAL	
HI-2115090	Proposed Rev. 3.I
I.3-23	

Table I.3.4.5

PROPRIETARY INFORMATION WITHHELD PER 10CFR2.390

HOLTEC INTERNATIONAL COPYRIGHTED MATERIAL

HI-2115090

Proposed Rev. 3.I

I.3-24

Table I.3.4.6

PROPRIETARY INFORMATION WITHHELD PER 10CFR2.390

HOLTEC INTERNATIONAL COPYRIGHTED MATERIAL

HI-2115090

Proposed Rev. 3.I

I.3-25

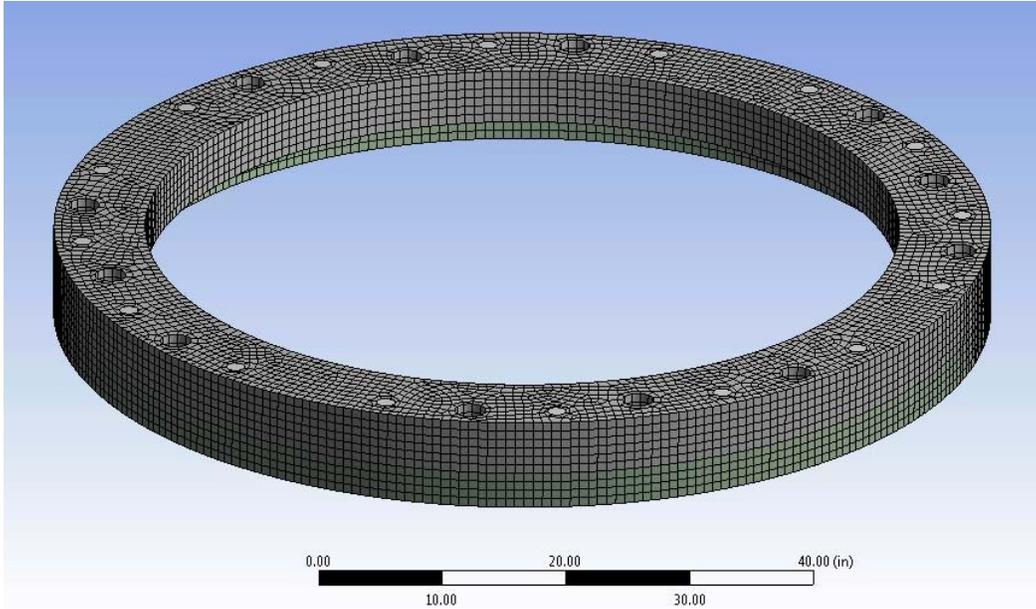

Figure I.3.4.1(a); 3-D ANSYS Model of Cask Handling Apparatus (CHA) Lid, Top Support Ring, and Lid Bolts

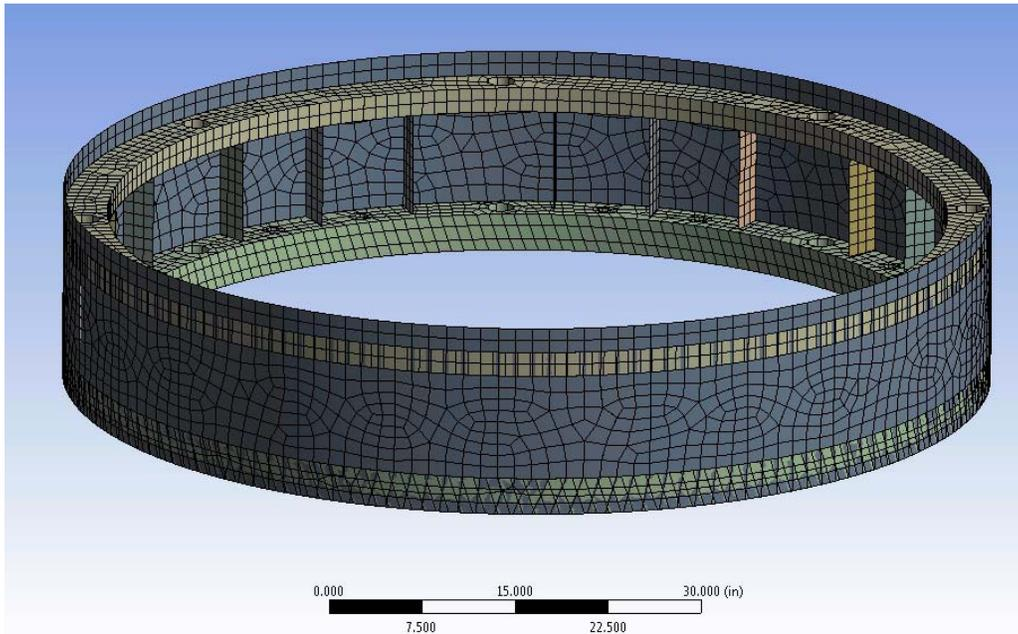

Figure I.3.4.1(b); 3-D ANSYS Model of Cask Handling Apparatus (CHA) Bottom Rings, Outer Shell, and Short Stiffeners

HOLTEC INTERNATIONAL COPYRIGHTED MATERIAL	
HI-2115090	Proposed Rev. 3.I
I.3-26	

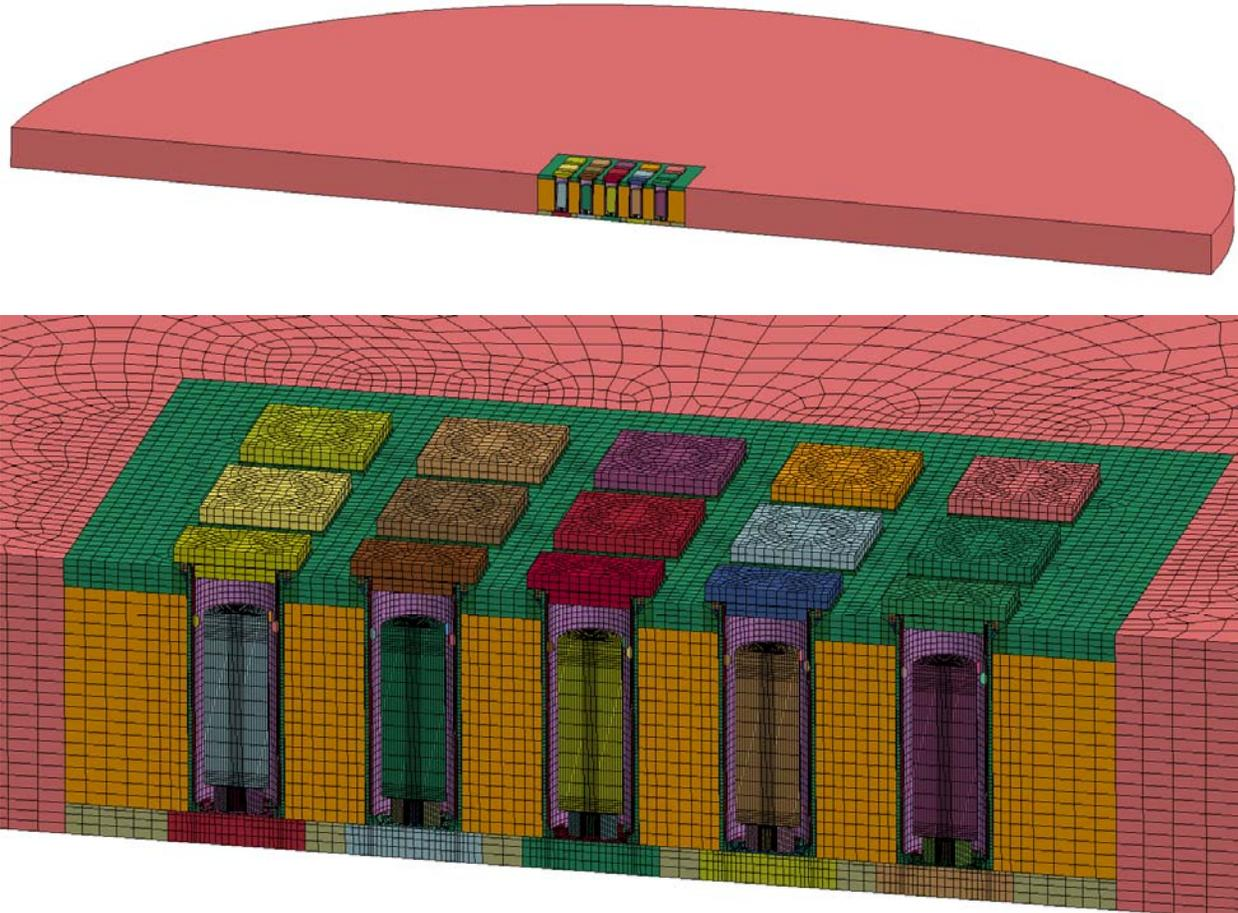

Figure I.3.4.2; 3-D LSDYNA Model for the Non-Linear SSI Analysis of the HI-STORM UMAX ISFSI Loaded with 24PT1-DSC Canisters

HOLTEC INTERNATIONAL COPYRIGHTED MATERIAL	
HI-2115090	Proposed Rev. 3.I
I.3-27	

I.3.5 FUEL RODS

Same as in Section 3.5 of the main body of this FSAR.

I.3.6 SUPPLEMENTAL DATA

Same as in Section 3.6 of the main body of this FSAR.

I.3.7 COMPLIANCE WITH THE STRUCTURAL REQUIREMENTS IN PART 72

Supporting information to provide reasonable assurance with respect to the adequacy of the HI-STORM UMAX system to store the 24PT1-DSC in accordance with the stipulations of 10CFR72 is presented throughout this FSAR. The following statements are applicable to an affirmative structural safety evaluation:

- The design and structural analysis of the HI-STORM UMAX System is in full compliance with the provisions of Chapter 3 of NUREG-1536 as appropriate for a vertical ventilated module assembly (see Table 3.7.1).
- The HI-STORM UMAX structures, systems, and components (SSC) that are important to safety (ITS) are identified in the Licensing Drawings in Sections 1.5 and I.1.5. The Licensing Drawings present the HI-STORM UMAX SSCs in adequate detail and the explanatory narratives in this chapter (including Supplement I.3) provide sufficient textual details to allow an independent evaluation of their structural effectiveness.
- The requirements of 10CFR72.24 with regard to information pertinent to structural evaluation are provided in Supplements I.2, I.3, and I.12.
- Technical Specifications pertaining to the structures of the HI-STORM UMAX system for storage of the 24PT1-DSC have been provided in Supplement I.13 herein pursuant to the requirements of 10CFR72.26.
- A series of analyses to demonstrate compliance with the requirements of 10CFR72.122(b) and (c), and 10CFR72.24(c)(3) have been performed which show that SSCs in the HI-STORM UMAX VVM designated as ITS possess an adequate margin of safety with respect to all load combinations applicable to normal, off-normal, accident, and natural phenomenon events. In particular, the following information is provided:
 - i. Load combinations for the HI-STORM UMAX VVM and the ISFSI structures for normal, off-normal, accident, and natural phenomenon events have been provided.

HOLTEC INTERNATIONAL COPYRIGHTED MATERIAL	
HI-2115090	Proposed Rev. 3.I
I.3-28	

- ii. Stress limits applicable to the Code materials can be found in Section 3.3.
 - iii. The stress and displacement response of the 24PT1-DSC canister, and the HI-STORM UMAX VVM for all applicable loads, have been computed by analysis and reported in Subsections I.3.4.3 and I.3.4.4. Descriptions of stress analysis models are presented in Subsection I.3.1.3.
- The criticality safety of the stored 24PT1-DSC is ensured by demonstrating that the maximum g-load sustained by the Canister stored inside the HI-STORM UMAX VVMs is less than its licensing basis value. This conclusion satisfies the requirement of 10CFR72.124(a), with respect to structural margins of safety for SSCs important to nuclear criticality safety.
 - Structural margins of safety during handling, packaging, and transfer operations, under the provisions of 10CFR Part 72.236(b), imply that the lifting and handling devices be engineered to comply with the stipulations of ANSI N14.6 and NUREG-0612. The requirements of the governing standards for handling operations are summarized in Subsection I.3.4.3 herein. Factors of safety for all ITS components under lifting and handling operations are summarized in tables in Section I.3.4, which show that adequate structural margins exist in all cases.
 - Consistent with the requirements of 10CFR72.236(i), the confinement boundary for the HI-STORM UMAX System has been engineered to maintain confinement of radioactive materials under normal, off-normal, and postulated accident conditions. This assertion of confinement integrity is made on the strength of the Canister’s licensing basis in docket number 72-1029 and the following information provided in this FSAR.
 - The information on structural design included in this FSAR complies with the requirements of 10CFR72.120 and 10CFR72.122.
 - The structural design features in the HI-STORM UMAX VVM (along with the previously certified 24PT1-DSC) are in compliance with the specific requirements of 10CFR72.236(e), (f), (g), (h), (i), (j), (k), and (m).

HOLTEC INTERNATIONAL COPYRIGHTED MATERIAL	
HI-2115090	Proposed Rev. 3.I
I.3-29	

I.3.8 REFERENCES

- [I.3.4.1] ANSYS 14.0, ANSYS Inc., 2011.
- [I.3.4.2] [Holtec International](#), “Structural Calculation Package for Storage of the 24PT1-DSC Inside HI-STORM UMAX Under the MSE Condition”, [HI-2167337](#), **Revision 1**, 2016

HOLTEC INTERNATIONAL COPYRIGHTED MATERIAL	
HI-2115090	Proposed Rev. 3.I
I.3-30	

SUPPLEMENT I.4: THERMAL EVALUATION OF 24PT1-DSC CANISTER

I.4.0 OVERVIEW

In this Supplement the thermal evaluation of the NUHOMS 24PT1-DSC [I.1.2.1] canister for vertical storage in the UMAX VVM is documented. As shown in this supplement, cooling of the canister by ventilation action is increased when it is arrayed vertically in “UMAX” because of the increase in the “chimney height” of the air column. As a result the 24PT1-DSC temperatures are lower than those that will obtain in the horizontal configuration in the NUHOMS module.

Supplement I adds the 24PT1-DSC canister to the HI-STORM UMAX system [I.1.2.1]. Only those design features of “UMAX” that are revised or added to incorporate the 24PT1-DSC canister are described in this chapter. This chapter also references to the main body of the FSAR where existing safety analyses are bounding, as applicable. The material in this supplement is organized to mirror the corresponding material in the main body of the FSAR with the letter I. inserted before each chapter/section/subsection/paragraph number. Thus the numeric sequence I.m.n.p.r indicates that the material belongs to Supplement I, Chapter #m, Section #n, subsection# p and paragraph # r. (m, n, p and r are numeric values). Thus, the numbering of the material in the supplement is readily distinguished from the main FSAR’s while the content correspondence is maintained.

The 24PT1-DSC canister is approved by the NRC for storage under Part 72, Docket No. 72-1029. The safety analysis information applicable to thermal analysis is incorporated by reference to the NUHOMS FSAR [I.1.2.1]. A roadmap of the referenced information is tabulated in Table I.4.0.1.

As described in the main body of this report the HI-STORM UMAX is an underground vertical ventilated module (VVM) with openings for air ingress and egress and internal air flow passages for ventilation cooling of the stored canisters. The main body of the FSAR evaluates storage of Holtec’s MPC-37 and MPC-89 canisters. In Supplement I the 24PT1-DSC canister is evaluated for storage in the “UMAX” VVM.

Supplement I.1 provides a general description of the 24PT1-DSC. In this chapter, thermal evaluation under storage of this canister in HI-STORM UMAX system using 3-D thermal models is performed. The analyses consider passive rejection of decay heat from the stored SNF assemblies to the environment under normal, off-normal, and accident conditions of storage. In particular, the thermal margins of safety under long-term storage of moderate burnup fuel[‡] (up to 45,000 MWD/MTU) are quantified. The HI-STORM UMAX deploys the same HI-TRAC VW transfer casks that are used in HI-STORM FW vertical ventilated system (USNRC Docket 72-1032) [I.1.2.3]. Safe thermal performance of 24PT1-DSC placed in HI-TRAC VW during short-

[‡] High Burnup Fuel is not authorized for storage in the 24PT1-DSC.

HOLTEC INTERNATIONAL COPYRIGHTED MATERIAL	
HI-2115090	Proposed Rev. 3.G
I.4-1	

term operations defined in Supplement I.9 is also evaluated. The cases of normal, off-normal and accident conditions of storage, enumerated in Supplement I.2 are also evaluated to establish an acceptable safety case for long term storage in the HI-STORM UMAX VVMs.

The thermal evaluation of HI-STORM UMAX follows the guidelines of NUREG-1536 [4.0.1] and ISG-11 [4.0.2] and the acceptance criteria set forth in Design Criteria Chapter 2 and Supplement I.2. These guidelines provide specific limits on the permissible maximum cladding temperature in the stored commercial spent fuel (CSF)[§] and other Confinement Boundary components, and on the maximum permissible pressure in the confinement space under certain operating scenarios. Specifically, the requirements are:

1. The fuel cladding temperature must meet the temperature limit appropriate to its burnup level and condition of storage / handling set forth in ISG-11 [4.0.2].
2. The maximum internal pressure of the 24PT1-DSC should remain within its design pressures for normal, off-normal, and accident conditions defined in NUHOMS FSAR Table 3.1-6 [I.1.2.1].
3. The temperatures of the cask and canister materials shall remain below their allowable limits set forth in Tables 2.3.7 and I.2.2.1 under all scenarios.

Section I.2.5 of this FSAR lists all thermally challenging scenarios that warrant analysis. Table I.2.1.2 in Supplement I.2 specifies the 24PT1-DSC Design Basis heat loads. As evaluated in this Supplement, the HI-STORM UMAX system is designed to comply with Supplement 2.I thermal criteria.

Sections I.4.1 through I.4.3 define the thermal input data that are common to all conditions of storage, handling and on-site transfer operations. All required thermal analyses to evaluate normal conditions of storage in a HI-STORM UMAX storage module are described in Section I.4.4. The thermal performance of the system is also evaluated under sustained wind conditions in Section I.4.4. Thermal analyses of on-site transfer in a HI-TRAC transfer cask are evaluated in Section I.4.5 and evaluation under off-normal and accident conditions are addressed in Section I.4.6.

To evaluate the storage of 24PT1-DSC in the UMAX VVM with the exception of 24PT1-DSC modeling** the same methodology defined in the main body of the FSAR for modeling the VVM and the ventilation cooling of the heater canister is adopted.

§ Defined as nuclear fuel that is used to produce energy in a commercial nuclear reactor (See Glossary).
 ** 24PT1-DSC modeling addressed in Section 4.4.

HOLTEC INTERNATIONAL COPYRIGHTED MATERIAL	
HI-2115090	Proposed Rev. 3.G
I.4-2	

Table I.4.0.1: Material Incorporated by Reference

Information Incorporated by Reference	Source of the Information	NRC Approval of Material Incorporated by Reference	Location in this FSAR where Material is Incorporated by Reference	Technical Justification of Applicability to HI-STORM UMAX
Canister Thermal Performance	NUHOMS FSAR Reference [I.1.2.1, Chapter 4, Section 4.4]	NUHOMS SER Reference [I.1.2.2]	I.4.4	The canister is the same as the one described in the FSAR and originally approved in the referenced SER.
Canister Material Properties	NUHOMS FSAR Reference [I.1.2.1, Chapter 4, Section 4.2]	NUHOMS SER Reference [I.1.2.2]	I.4.2	The canister is the same as the one described in the FSAR and originally approved in the referenced SER.
Canister in NUHOMS Transfer Cask thermal evaluation	NUHOMS FSAR Reference [I.1.2.1, Chapter 4, Subsection 4.4.3]	NUHOMS SER Reference [I.1.2.2]	I.4.5	The canister is the same as the one described in the FSAR and originally approved in the referenced SER.
Canister Design Pressure	NUHOMS FSAR Reference [I.1.2.1, Chapter 3, Table 3.1-6]	NUHOMS SER Reference [I.1.2.2]	I.4.4.6	The canister is the same as the one described in the FSAR and originally approved in the referenced SER.
Canister in NUHOMS Transfer Cask fire accident evaluation	NUHOMS FSAR Reference [I.1.2.1, Chapter 4, Subsection 4.6.4]	NUHOMS SER Reference [I.1.2.2]	I.4.6	The canister is the same as the one described in the FSAR and originally approved in the referenced SER.
<u>NUHOMS AHSM Module description</u>	<u>NUHOMS FSAR Reference [I.1.2.1, Chapter 1, Section 1.1]</u>	<u>NUHOMS SER Reference [I.1.2.2]</u>	<u>I.4.4</u>	<u>The module is the same as the one described in the FSAR and originally approved in the referenced SER.</u>

HOLTEC INTERNATIONAL COPYRIGHTED MATERIAL

HI-2115090

Proposed Rev. 3.G

I.4-3

I.4.1 DESIGN BASIS HEAT LOAD

The 24PT1-DSC canister and fuel design heat loads are specified in Table I.2.1.2. The decay heat is conservatively modeled in the thermal analysis as non-uniformly distributed heat source in the active fuel region with peaking in the middle as defined in the main body of the UMAX FSAR (See Supplement I.2, Table I.2.1.4).

HOLTEC INTERNATIONAL COPYRIGHTED MATERIAL	
HI-2115090	Proposed Rev. 3.G
I.4-4	

I.4.2 SUMMARY OF THERMAL PROPERTIES OF MATERIALS

Except for 24PT1-DSC the thermo-physical properties relevant to thermal evaluation are same as defined in the main body Section 4.2 of the FSAR which provides properties of materials present in the HI-STORM UMAX VVM such as carbon steel, insulation, concrete (in the Closure Lid) and air. These same properties are used herein. The 24PT1-DSC modeling as articulated in Section I.4.4 requires properties of its stainless steel pressure boundary which are obtained from the NUHOMS FSAR [I.1.2.1] and compiled in Table I.4.2.1.

HOLTEC INTERNATIONAL COPYRIGHTED MATERIAL	
HI-2115090	Proposed Rev. 3.G
I.4-5	

Table I.4.2.1: Thermal Properties of 24PT1-DSC Pressure Boundary ^{Note 1}

	@70°F	@200°F	@400°F	@600°F	@800°F
SA-240 Conductivity (Btu/ft-hr-°F)	7.7	8.4	9.5	10.5	11.5
SA-537 Conductivity (Btu/ft-hr-°F)	23.6	24.4	24.2	23.1	-
SA-240 Thermal Diffusivity (ft ² /hr)	0.134	0.141	0.151	0.162	0.173
SA-537 Thermal Diffusivity (ft ² /hr)	0.454	0.422	0.386	0.346	-
SA-240 Density (lbm/in ³)	0.285				
SA-537 Density (lbm/in ³)	0.284				
Emissivity	0.40 – Stainless Steel 0.587 – 24PT1 DSC Shell Surface				
Note 1: Properties obtained from Section 4.2 of NUHOMS FSAR [I.1.2.1] .					

HOLTEC INTERNATIONAL COPYRIGHTED MATERIAL

HI-2115090

Proposed Rev. 3.G

I.4-6

I.4.3 SPECIFICATIONS FOR COMPONENTS

Permissible temperatures for the HI-STORM UMAX VVM and 24PT1-DSC materials and components designated as “Important to Safety” (i.e., required to be maintained within safe operating temperatures to ensure their intended function) are defined in Chapter 2, Table 2.3.7 and Supplement I.2, Table I.2.2.1. Long-term integrity of SNF requires fuel cladding be maintained below ISG-11, Rev. 3 regulatory limits [4.0.2] which are tabulated in Table I.4.3.1.

Compliance with 10CFR72 requires, in part, identification and evaluation of short-term, off-normal and hypothetical accident events and compliance with corresponding FSAR limits. These limits are addressed in the tables cited above.

HOLTEC INTERNATIONAL COPYRIGHTED MATERIAL	
HI-2115090	Proposed Rev. 3.G
I.4-7	

Table I.4.3.1: Fuel Cladding Temperature Limits

Condition	Limit (°F)^{Notes 1, 2}
Normal	752
Short Term Operations, Off-normal and Accident	1058
Note 1: Moderate burnup fuel limits tabulated in accordance with ISG-11, Rev. 3 [4.0.2].	
Note 2: High burnup fuel not permitted in the 24PT1-DSC.	

HOLTEC INTERNATIONAL COPYRIGHTED MATERIAL	
HI-2115090	Proposed Rev. 3.G
I.4-8	

I.4.4 THERMAL EVALUATION UNDER NORMAL CONDITIONS OF STORAGE

24PT1-DSC storage in the UMAX VVM is evaluated using a suitably calibrated thermal model of the canister that conservatively represents the temperatures in its licensed configuration as articulated in the NUHOMS FSAR [I.1.2.1]. The canister model is then incorporated in the UMAX thermal model as articulated in the main body of the FSAR and evaluated under the licensing basis scenarios in this Supplement. All analyses including model calibration use the approved and benchmarked FLUENT Computational Fluid Dynamics program [4.4.3] utilized in all Holtec cask docket.

I.4.4.1 Analysis Approach

(a) Input data

The following information on the canister's thermal performance under storage in the AHSM module is available from the canister's native docket [I.1.2.1]:

- i) The inlet and outlet temp of air (t and T)
- ii) Air flow rate , $W^{\dagger\dagger}$
- iii) Insolation heat, S
- iv) Corresponding peak cladding temperature in the stored fuel, C
- v) Canister heat load, Q

As shown in the following the above data is adequate for proper thermal characterization of the canister.

[

PROPRIETARY INFORMATION WITHHELD PER 10CFR2.390

]

$\dagger\dagger$ Ascertained from the canister heat load and co-incident outlet air temperature rise.

HOLTEC INTERNATIONAL COPYRIGHTED MATERIAL	
HI-2115090	Proposed Rev. 3.G
I.4-9	

[

PROPRIETARY INFORMATION WITHHELD PER 10CFR2.390

]

HOLTEC INTERNATIONAL COPYRIGHTED MATERIAL	
HI-2115090	Proposed Rev. 3.G
I.4-10	

(c) NUHOMS AHSM Model

The NUHOMS AHSM is a horizontal concrete storage cask engineered with inlets and outlets to facilitate ventilation cooling as articulated in the NUHOMS FSAR [I.1.2.1]. The NUHOMS AHSM description is incorporated in this chapter by reference (See Table I.4.0.1). Principal construction data relevant to supporting NUHOMS AHSM thermal modeling is tabulated in Table I.4.4.8.

The FLUENT model of NUHOMS AHSM with 24PT1-DSC situated in it has the same features as the NUHOMS FSAR thermal model. The principal features are as follows:

[

PROPRIETARY INFORMATION WITHHELD PER 10CFR2.390

]

[

PROPRIETARY INFORMATION WITHHELD PER 10CFR2.390

]

A 3D rendering of the FLUENT thermal model is depicted in Figure I.4.4.1.

(d) Model Calibration

HOLTEC INTERNATIONAL COPYRIGHTED MATERIAL	
HI-2115090	Proposed Rev. 3.G
I.4-11	

The necessary NUHOMS thermal inputs as defined in this section are tabulated in Table I.4.4.1.
[

PROPRIETARY INFORMATION WITHHELD PER 10CFR2.390

]
The results confirm the adequacy of the homogenized model as a conservative method for thermal evaluation of canisters loaded with spent nuclear fuel. The calibrated parameters thus obtained are tabulated in Table I.4.4.3 and adopted to evaluate 24PT1-DSC in the “UMAX” system.

I.4.4.2 UMAX Thermal Model

[

PROPRIETARY INFORMATION WITHHELD PER 10CFR2.390

[]

PROPRIETARY INFORMATION WITHHELD PER 10CFR2.390

HOLTEC INTERNATIONAL COPYRIGHTED MATERIAL	
HI-2115090	Proposed Rev. 3.G
I.4-12	

]

I.4.4.3 Grid Sensitivity Studies

The grid sensitivity studies reported in Chapter 4, Subsection 4.4.2 in the main body of the FSAR remain applicable. The same licensing basis UMAX VVM mesh articulated in the main body is adopted herein.

I.4.4.4 Test Model

The HI-STORM UMAX thermal analysis is performed on the FLUENT [4.4.3] Computational Fluid Dynamics (CFD) program. To ensure a high degree of confidence in the HI-STORM UMAX thermal evaluations, the FLUENT code has been benchmarked using data from tests conducted with casks loaded with irradiated SNF ([4.4.4], [4.4.6]). The benchmark work is archived in QA validated Holtec reports ([4.4.1], [4.4.5]). These evaluations show that the FLUENT solutions are conservative in all cases. In view of these considerations, additional experimental verification of the thermal design is not necessary. Furthermore, FLUENT is relied to secure certification in all Holtec International Part 71 and Part 72 docket.

I.4.4.5 Maximum and Minimum Temperatures

[

PROPRIETARY INFORMATION WITHHELD PER 10CFR2.390

]

HOLTEC INTERNATIONAL COPYRIGHTED MATERIAL	
HI-2115090	Proposed Rev. 3.G
I.4-13	

[

PROPRIETARY INFORMATION WITHHELD PER 10CFR2.390

]

HOLTEC INTERNATIONAL COPYRIGHTED MATERIAL	
HI-2115090	Proposed Rev. 3.G
I.4-14	

[

PROPRIETARY INFORMATION WITHHELD PER 10CFR2.390

]

I.4.4.6 Maximum Internal Pressure in the DSC

As is standard practice, the 24PT1-DSC is helium filled prior to storage. During normal storage, the gas temperature within the 24PT1-DSC rises to its maximum operating basis temperature. The gas pressure inside the MPC will also increase with rising ambient temperature which can be determined using the ideal gas law. The 24PT1-DSC is also subject to pressure rise under hypothetical release of gases as evaluated in the NUHOMS FSAR [I.4.0.3]. The gas release quantities are tabulated in Table I.2.2.1. Based on fission gases release fractions (NUREG 1536 criteria [I.4.0.1]) the maximum gas pressures with 1% (normal), 10% (off-normal) and 100% (accident condition) rod rupture are computed and tabulated in Table I.4.4.6. The computed pressures comply with 24PT1-DSC design pressures (NUHOMS FSAR Table 3.1-6 [I.1.2.1]) pressure limits.

HOLTEC INTERNATIONAL COPYRIGHTED MATERIAL	
HI-2115090	Proposed Rev. 3.G
I.4-15	

I.4.4.7 Engineered Clearances to Eliminate Thermal Interferences

The NUHOMS FSAR addresses 24PT1-DSC thermal interferences under temperatures reached in the NUHOMS storage system [I.1.2.1]. As the operating temperatures under UMAX storage are lower the co-incident thermal expansions are lesser.

I.4.4.8 Effect of Elevation

Storage of 24PT1-DSC in the UMAX VVM is evaluated under standard 1 atm. pressure conditions. If conditions at a site are substantially different then site-specific evaluation should be performed to ensure safety compliance.

I.4.4.9 Burnup Effects on Fuel Conductivity

[See Chapter 4, Section 4.4.8.](#)

I.4.4.10 Evaluation of Sustained Wind

As evaluated in main body of the report wind has a second order effect on the performance of UMAX structures. Under a worst case scenario wherein wind is postulated as a sustained condition of a certain magnitude and direction to maximize its effects temperature increments on the order of ~30°F are obtained. As 24PT1-DSC thermal margins are an order of magnitude greater (~200-250°F) this condition does not challenge the safety of stored fuel.

I.4.4.11 Evaluation of System Performance for Normal Conditions of Storage

The HI-STORM UMAX System thermal analysis is based on a detailed 3-D heat transfer model that conservatively accounts the principal modes of heat transfer in the canister and overpack. The thermal model incorporates conservative assumptions that render the computed temperature results for long-term storage to be conservative. The computed temperatures in “UMAX” under design basis heat load comply with the licensing limits as summarized below:

- a. The peak cladding temperature is below the ISG-11 Rev 3 limit.
- b. The temperatures of structural members in the VVM and 24PT1-DSC are below their allowable values set down in the Chapter 2 (presented in Table 2.3.7) and Supplement 2.I (Table I.2.2.1) with positive margins.
- c. The temperature of shielding concrete and insulation (both non-structural members) are well within stipulated limits set forth in Table 2.3.7.

The modest metal temperatures reached in “UMAX” insure that the components of the system will not suffer long term degradation from elevated temperature effects such as creep, alloy phase transformation, recrystallization of the materials’ grain structure, and the like. Therefore, safety of long term storage from the thermal standpoint is assured.

HOLTEC INTERNATIONAL COPYRIGHTED MATERIAL	
HI-2115090	Proposed Rev. 3.G
I.4-16	

I.4.4.12 Homogenized Canister Methodology Benchmarking

The homogenized canister methodology articulated in Section I.4.4.1 is benchmarked with the aid of 3D CFD models of spent fuel storage casks. [

PROPRIETARY INFORMATION WITHHELD PER 10CFR2.390

1

HOLTEC INTERNATIONAL COPYRIGHTED MATERIAL	
HI-2115090	Proposed Rev. 3.G
I.4-17	

I

PROPRIETARY INFORMATION WITHHELD PER 10CFR2.390

I

HOLTEC INTERNATIONAL COPYRIGHTED MATERIAL	
HI-2115090	Proposed Rev. 3.G
I.4-18	

Table I.4.4.1: PROPRIETARY INFORMATION WITHHELD PER 10CFR2.390

Table I.4.4.2: PROPRIETARY INFORMATION WITHHELD PER 10CFR2.390

HOLTEC INTERNATIONAL COPYRIGHTED MATERIAL	
HI-2115090	Proposed Rev. 3.G
I.4-19	

Table I.4.4.3: PROPRIETARY INFORMATION WITHHELD PER 10CFR2.390

Table I.4.4.4: PROPRIETARY INFORMATION WITHHELD PER 10CFR2.390

HOLTEC INTERNATIONAL COPYRIGHTED MATERIAL	
HI-2115090	Proposed Rev. 3.G
I.4-20	

Table I.4.4.5: PROPRIETARY INFORMATION WITHHELD PER 10CFR2.390

HOLTEC INTERNATIONAL COPYRIGHTED MATERIAL	
HI-2115090	Proposed Rev. 3.G
I.4-21	

Table I.4.4.6: PROPRIETARY INFORMATION WITHHELD PER 10CFR2.390

Table I.4.4.7: DELETED

HOLTEC INTERNATIONAL COPYRIGHTED MATERIAL	
HI-2115090	Proposed Rev. 3.G
I.4-22	

Table I.4.4.8: PROPRIETARY INFORMATION WITHHELD PER 10CFR2.390

HOLTEC INTERNATIONAL COPYRIGHTED MATERIAL	
HI-2115090	Proposed Rev. 3.G
I.4-23	

Table I.4.4.9: DELETED

Table I.4.4.10: PROPRIETARY INFORMATION WITHHELD PER 10CFR2.390

HOLTEC INTERNATIONAL COPYRIGHTED MATERIAL	
HI-2115090	Proposed Rev. 3.G
I.4-24	

Table I.4.4.11: PROPRIETARY INFORMATION WITHHELD PER 10CFR2.390

Table I.4.4.12: PROPRIETARY INFORMATION WITHHELD PER 10CFR2.390

HOLTEC INTERNATIONAL COPYRIGHTED MATERIAL	
HI-2115090	Proposed Rev. 3.G
I.4-25	

Table I.4.4.13: PROPRIETARY INFORMATION WITHHELD PER 10CFR2.390

Table I.4.4.14: PROPRIETARY INFORMATION WITHHELD PER 10CFR2.390

HOLTEC INTERNATIONAL COPYRIGHTED MATERIAL	
HI-2115090	Proposed Rev. 3.G
I.4-26	

Table I.4.4.15: PROPRIETARY INFORMATION WITHHELD PER 10CFR2.390

Table I.4.4.16: PROPRIETARY INFORMATION WITHHELD PER 10CFR2.390

Table I.4.4.17: PROPRIETARY INFORMATION WITHHELD PER 10CFR2.390

HOLTEC INTERNATIONAL COPYRIGHTED MATERIAL	
HI-2115090	Proposed Rev. 3.G
I.4-27	

Table I.4.4.18: PROPRIETARY INFORMATION WITHHELD PER 10CFR2.390

HOLTEC INTERNATIONAL COPYRIGHTED MATERIAL	
HI-2115090	Proposed Rev. 3.G
I.4-28	

Figure I.4.4.1: **PROPRIETARY INFORMATION WITHHELD PER 10CFR2.390**

HOLTEC INTERNATIONAL COPYRIGHTED MATERIAL	
HI-2115090	Proposed Rev. 3.G
I.4-29	

Figure I.4.4.2: PROPRIETARY INFORMATION WITHHELD PER 10CFR2.390

HOLTEC INTERNATIONAL COPYRIGHTED MATERIAL	
HI-2115090	Proposed Rev. 3.G
I.4-30	

Figure I.4.4.3: PROPRIETARY INFORMATION WITHHELD PER 10CFR2.390

HOLTEC INTERNATIONAL COPYRIGHTED MATERIAL	
HI-2115090	Proposed Rev. 3.G
I.4-31	

Figure I.4.4.4: PROPRIETARY INFORMATION WITHHELD PER 10CFR2.390

HOLTEC INTERNATIONAL COPYRIGHTED MATERIAL	
HI-2115090	Proposed Rev. 3.G
I.4-32	

I.4.5 SHORT-TERM OPERATIONS

Short-Term Operations as applicable to the 24PT1-DSC (See Supplement I.9) are those activities that are required to relocate it from a NUHOMS storage module to Holtec’s licensed HI-TRAC VW followed by on-site transfer and placement in the “UMAX” VVM. In the regulatory literature, all activities that involve the handling and placement of canisters on the ISFSI pad or retrieval from ISFSI under an unlikely scenario requiring fuel unloading are collectively referred to as Short Term Operations. These activities are required to comply with ISG-11, Rev. 3 temperature limits [I.4.0.2] (See Table I.4.3.1). All short term operations have one common feature: They all involve the transfer cask. The qualification of Short Term Operations, therefore, is integral to the certification of the transfer cask. This FSAR deploys the HI-TRAC VW transfer cask certified in the HI-STORM FW FSAR [I.I.1.2.3] for 24PT1-DSC transfer operations.

I.4.5.1 Thermally Limiting Evolutions During Short-Term Operations

The following scenarios are thermally limiting under 24PT1-DSC short term operational evolutions defined in Supplement I.9:

- a) Horizontal transfer of 24PT1-DSC to NUHOMS Transfer Cask
- b) Horizontal transfer to HI-TRAC VW Cask
- c) Vertical on-site transfer of loaded HI-TRAC VW
- d) 24PT1-DSC transfer to UMAX VVM and retrieval operations

Scenario a) is addressed in the NUHOMS FSAR [I.1.2.1, Chapter 4, Section 4.5]. The thermal evaluation is incorporated by reference (See Table I.4.0.1]. Scenarios b) and c) and d) are addressed in the following.

I.4.5.2 HI-TRAC VW Thermal Model

[

PROPRIETARY INFORMATION WITHHELD PER 10CFR2.390

]

HOLTEC INTERNATIONAL COPYRIGHTED MATERIAL	
HI-2115090	Proposed Rev. 3.G
I.4-33	

I.4.5.3 Maximum Time Limit During Wet Transfer Operations

Not applicable, as the canister is already loaded and stored in NUHOMS.

I.4.5.4 Analysis of Limiting Thermal States During Short-Term Operations

I.4.5.4.1 Vacuum Drying

The canister is already loaded, therefore this evolution is not applicable.

I.4.5.4.2 Forced Helium Dehydration

The canister is already loaded, therefore this evolution is not applicable.

I.4.5.4.3 Normal On-Site Transfer

[

PROPRIETARY INFORMATION WITHHELD PER 10CFR2.390

]

I.4.5.4.4 Canister UMAX Loading and Retrieval Operations

[

PROPRIETARY INFORMATION WITHHELD PER 10CFR2.390

]

HOLTEC INTERNATIONAL COPYRIGHTED MATERIAL	
HI-2115090	Proposed Rev. 3.G
I.4-34	

I.4.5.5 Fuel Retrievability

In accordance with ISG-2, Rev. 2^{‡‡}, fuel retrievability is defined as:

“Ready retrieval: The ability to safely remove the spent fuel from storage for further processing or disposal.”

The UMAX system is suitably designed to retrieve fuel in accordance with Option B permitted in the ISG-2, Rev. 2 wherein the applicant is required to demonstrate removal of loaded canister from the storage overpack. As described in Operations Supplement I.9 a loaded 24PT1-DSC canister is retrieved from the UMAX VVM by transfer to a HI-TRAC VW and on-site transport to facilitate further processing. Thermal compliance of the transfer configuration and on-site transfer are addressed in the sections above.

I.4.5.6 Maximum Internal Pressure

During on-site transfer operations in the HI-TRAC VW transfer cask, the 24PT1-DSC helium pressure will correspond in accordance with Ideal Gas Law to the thermal conditions within it as analyzed in Section I.4.5.4. The computed pressures are tabulated in Table I.4.5.1. The pressure remains within NUHOMS FSAR Table 3.1-6 [I.1.2.1] pressure limits.

I.4.5.7 Fuel Unloading from Canister

Sites requiring access to fuel assemblies may conduct unloading operations as evaluated in the NUHOMS FSAR [I.1.2.1, Chapter 3, Section 3.5.4]. This operation is non-mandatory under ISG-2, Rev. 2 Option B requirements as adopted in Subsection I.4.5.5.

^{‡‡} “Fuel Retrievability in Spent Fuel Storage Applications”, Interim Staff Guidance-2, Rev. 2, Approved 4/26/16.

HOLTEC INTERNATIONAL COPYRIGHTED MATERIAL	
HI-2115090	Proposed Rev. 3.G
I.4-35	

Table I.4.5.1: PROPRIETARY INFORMATION WITHHELD PER 10CFR2.390

HOLTEC INTERNATIONAL COPYRIGHTED MATERIAL	
HI-2115090	Proposed Rev. 3.G
I.4-36	

I.4.6 OFF-NORMAL AND ACCIDENT EVENTS

The HI-STORM UMAX System safety under off-normal and accident conditions specified in Supplement 2.I is evaluated in this section. The HI-STORM UMAX System is evaluated under design basis 24PT1-DSC heat load defined in Section I.4.1.

I.4.6.1 Off-Normal Events

I.4.6.1.1 Off-Normal Environmental Temperature

As justified in Chapter 4, Section 4.6 the UMAX System temperature elevation under off-normal ambient condition is suitably obtained by the difference $\delta = 20^{\circ}\text{F}$ in ambient temperature under off-normal (100°F) and normal (80°F) temperatures. Inspection of the normal ambient UMAX temperatures evaluated in Table I.4.4.4 support the observation that margins to off-normal temperature limits are well in excess of δ . This supports the conclusion that safe operating temperatures under off-normal ambient condition is reasonably assured. The canister pressure under the increased temperature is computed in accordance with Ideal Gas Law and tabulated in Table I.4.6.5. The pressure complies with NUHOMS FSAR off-normal design limits [I.1.2.1, Chapter 3, Table 3.1-6].

I.4.6.1.2 Partial Blockage of Air Inlets

The HI-STORM UMAX system is designed with debris screens installed on the inlet and outlet openings. These screens ensure the air passages are protected from entry and blockage by foreign objects. However, as required by the design criteria presented in Chapter I.2, it is postulated that the HI-STORM UMAX air inlet vents are 50% blocked. The resulting decrease in flow area increases the flow resistance of the inlet ducts. The effect of the increased flow resistance on fuel temperature is analyzed assuming that steady state conditions have been reached. The computed temperatures and pressures are reported in Table I.4.6.1. The results are confirmed to be below the fuel cladding, UMAX VVM and DSC-24PT1 temperature limits.

I.4.6.1.3 Off-Normal Pressure

This event is defined as a combination of (a) helium backfill, (b) 10% fuel rods rupture, (c) design heat load and (d) normal ambient temperature defined in Section I.2.2. The principal objective of the analysis is to demonstrate that the 24PT1-DSC off-normal design pressure (Table I.2.2.1) is not exceeded. Table I.4.4.6 provides the computed pressures for the off-normal event as defined above which shows that the pressure complies with the off-normal pressure limit.

I.4.6.1.4 FHD Malfunction

FHD is not relied for operations involving the 24PT1-DSC, therefore this event is not applicable.

HOLTEC INTERNATIONAL COPYRIGHTED MATERIAL	
HI-2115090	Proposed Rev. 3.G
I.4-37	

I.4.6.2 Accident Events

I.4.6.2.1 Fire Accident

(a) HI-STORM UMAX Fire

Under design basis fire accident the UMAX VVM exposed surfaces are subject to intense heating under the incident fire flux. Thermal calculations in the main body of the FSAR show that the large mass of concrete protects loaded canister from the brunt of direct heating. The fuel temperatures are essentially unchanged (~1°F temperature rise computed) and shell temperatures are unaffected by fire accident (~4°F temperature rise). These evaluations support the safety case that 24PT1-DSC storage in UMAX VVM is not challenged by fire accident.

(b) Transfer Cask Fire

[

PROPRIETARY INFORMATION WITHHELD PER 10CFR2.390

]

HOLTEC INTERNATIONAL COPYRIGHTED MATERIAL	
HI-2115090	Proposed Rev. 3.G
I.4-38	

I.4.6.2.2 Extreme Environmental Temperatures

As justified in Chapter 4, Section 4.6 the UMAX System temperature elevation under off-normal ambient condition is suitably obtained by the difference $\delta = 45^\circ\text{F}$ ambient temperature under extreme ambient (125°F) and normal (80°F) temperatures. Inspection of the normal ambient UMAX temperatures evaluated in Table I.4.4.4 support the observation that margins to off-normal temperature limits are well in excess of δ . This supports the safety conclusion that safe operating temperatures under extreme ambient condition are below the regulatory limit. The canister pressure under the increased temperature is computed in accordance with Ideal Gas Law and tabulated in Table I.4.6.5. The pressure complies with NUHOMS FSAR accident limits [I.1.2.1, Chapter 3, Table 3.1-6].

4.6.2.3 100% Blockage of Air Inlets

[

PROPRIETARY INFORMATION WITHHELD PER 10CFR2.390

]

I.4.6.2.4 Burial under Debris

Burial of the HI-STORM UMAX system under debris is not a credible accident. During storage at an ISFSI there are no structures that loom over the casks whose collapse could completely bury the casks in debris. Minimum regulatory distances from the ISFSI to the nearest ISFSI security fence precludes close proximity of substantial amount of vegetation. There is no credible

HOLTEC INTERNATIONAL COPYRIGHTED MATERIAL	
HI-2115090	Proposed Rev. 3.G
I.4-39	

mechanism for the HI-STORM UMAX to be completely buried under debris. However, as defense-in-depth, a complete burial under debris is postulated and evaluated below.

[

PROPRIETARY INFORMATION WITHHELD PER 10CFR2.390

]

I.4.6.2.5 Flood

The flood accident temperatures under 24PT1-DSC storage are bounded by the MPC in UMAX flood accident analyzed in Chapter 4, Section 4.6 as supported by following reasoning:

- a) Reduced ventilation cooling demand due to substantially lower heat load under 24PT1-DSC storage.
- b) Enhanced canister cooling supported by enlarged annulus flow area under 24PT1-DSC storage.
- c) Lower fuel, canister and UMAX storage temperatures under 24PT1-DSC storage.

In light of the above the UMAX flood accident temperatures under MPC storage tabulated in

HOLTEC INTERNATIONAL COPYRIGHTED MATERIAL	
HI-2115090	Proposed Rev. 3.G
I.4-40	

Chapter 4, Table 4.6.9 are adopted for 24PT1-DSC evaluation. Inspection of the temperatures support compliance with fuel and DSC accident temperature limits specified in Tables I.4.3.1 and I.2.2.1.

Flood Recovery Actions

It is required in this FSAR to treat the recovery operation from flood as a blocked duct event (analyzed in the foregoing) for the affected VVM cavity by the ISFSI Owner *with the time clock to remove water and clear up the flow passages beginning as soon as the water in the cavity drops below the top surface of the stored MPC.*

I.4.6.2.6 Jacket Water Loss

The Jacket Water loss accident involves the loss of water medium in the HI-TRAC VW overpack peripheral spaces. This results in an increased resistance to the lateral dissipation of heat and a concomitant temperature adder to the loaded canister and stored fuel. This event is analyzed using the same thermal model articulated in Section I.4.5 assuming all water in the jacket is replaced by air. The computed temperatures and pressures are tabulated in Table I.4.6.2. The temperatures comply with fuel, DSC and HI-TRAC VW accident limits specified in Tables I.4.3.1, I.2.2.1 and main body Table 2.3.7 and 24PT1-DSC pressure limits specified in NUHOMS FSAR Table 3.1-6 [I.1.2.1].

HOLTEC INTERNATIONAL COPYRIGHTED MATERIAL	
HI-2115090	Proposed Rev. 3.G
I.4-41	

Table I.4.6.1: PROPRIETARY INFORMATION WITHHELD PER 10CFR2.390

HOLTEC INTERNATIONAL COPYRIGHTED MATERIAL	
HI-2115090	Proposed Rev. 3.G
I.4-42	

Table I.4.6.2: PROPRIETARY INFORMATION WITHHELD PER 10CFR2.390

HOLTEC INTERNATIONAL COPYRIGHTED MATERIAL	
HI-2115090	Proposed Rev. 3.G
I.4-43	

Table I.4.6.3: PROPRIETARY INFORMATION WITHHELD PER 10CFR2.390

HOLTEC INTERNATIONAL COPYRIGHTED MATERIAL	
HI-2115090	Proposed Rev. 3.G
I.4-44	

Table I.4.6.4: PROPRIETARY INFORMATION WITHHELD PER 10CFR2.390

Table I.4.6.5: PROPRIETARY INFORMATION WITHHELD PER 10CFR2.390

HOLTEC INTERNATIONAL COPYRIGHTED MATERIAL	
HI-2115090	Proposed Rev. 3.G
I.4-45	

I.4.7 REGULATORY COMPLIANCE

Thermal compliance pursuant to the provisions of NUREG [4.0.1] and ISG-11 [4.0.2] of 24PT1-DSC in the HI-STORM UMAX system has been considered in this supplement. NUREG-1536 [4.0.1] and ISG-11 [4.0.2] define thermal acceptance criteria that must be applied to evaluations of normal conditions of storage. These are addressed in Sections I.2.1 and I.4.1. Each of the pertinent criteria and the conclusion of the evaluations are summarized herein.

As required by ISG-11 [4.0.2], the fuel cladding temperature at the beginning of dry storage is maintained below the anticipated damage-threshold temperatures for normal conditions for the licensed life of the HI-STORM UMAX System. Maximum fuel cladding temperatures for long-term storage conditions are reported in Section I.4.4.

As required by NUREG-1536 [4.0.1], the maximum internal pressure of the canister remains within its design pressure for normal conditions, under postulated rupture of 1 percent of the fuel rods. Assumptions for pressure calculations include release of 100 percent of the fill gas and 30 percent of the significant radioactive gases in the fuel rods. Maximum internal pressures are reported in Section I.4.4 and shown to remain below the normal design pressures specified in Table 3.1-6 of NUHOMS FSAR [I.1.2.1].

As required by NUREG-1536 [4.0.1], all VVM, DSC components and fuel materials are maintained within their minimum and maximum temperature for normal and off-normal conditions in order to enable components to perform their intended safety functions. Maximum and minimum temperatures for normal, off-normal and accident long-term storage conditions are reported in Sections I.4.4 and I.4.6 which are evaluated to be well below their respective Design temperature limits summarized in Tables 2.3.7, I.2.2.1 and I.4.3.1.

As required by NUREG-1536 [4.0.1], the system ensures a very low probability of cladding breach during long-term storage. For long-term normal conditions, the maximum CSF cladding temperature remains below the ISG-11 [4.0.2] limit of 400°C (752°F).

As required by NUREG-1536 [4.0.1], the system is passively cooled. All heat rejection mechanisms described in this chapter, including conduction, natural convection, and thermal radiation, are passive.

As required by NUREG-1536 [4.0.1], the thermal performance of the system is within the allowable design criteria specified in SAR Supplements I.2 and I.4 for normal conditions. All thermal results reported in Section I.4.4 are within the design criteria under all normal conditions of storage.

The thermal compliance of short term operations is presented in Section I.4.5 wherein complete compliance with the provisions of ISG-11 [4.0.2] is demonstrated. In particular, the ISG-11 requirement to ensure that maximum cladding temperatures under all fuel loading and short-term operations be below 570°C (1058°F) under authorized burnups (moderate burnup fuel) is

HOLTEC INTERNATIONAL COPYRIGHTED MATERIAL	
HI-2115090	Proposed Rev. 3.G
I.4-46	

demonstrated.

As required by NUREG-1536 [4.0.1], the maximum internal pressure of the 24PT1-DSC is evaluated and shown to remain within its off-normal and accident design pressure, assuming rupture of 10 percent and 100 percent of the fuel rods, respectively. Assumptions for pressure calculations include release of 100 percent of the fill gas and 30 percent of the significant radioactive gases in the fuel rods.

It is therefore concluded that all applicable regulatory requirements and guidelines germane to demonstrating the integrity of the 24PT1-DSC canister in the “UMAX” storage system have been addressed and satisfied in this chapter.

HOLTEC INTERNATIONAL COPYRIGHTED MATERIAL	
HI-2115090	Proposed Rev. 3.G
I.4-47	

I.4.8 REFERENCES

[I.4.4.1] Holtec International, “Thermal Evaluation of HI-STORM UMAX System Loaded with 24PT1-DSC,” HI-2167272, Rev. 2.

[I.4.4.2] HI-STORM 100 FSAR, Holtec Report HI-2002444, Rev. 15.

[I.4.4.3] “Standard for Verification and Validation in Computational Fluid Dynamics and Heat Transfer”, ASME V&V 20-2009.

[I.4.4.4] “Absolute Measurement of the Thermal Conductivity of Helium and Hydrogen”, Mustafa M., Ross R. D., Trengove W., A. Wakeham, M. Zalaf, Physica A: Statistical Mechanics and its Applications, Vol. 141, Issue 1, February 1987.

[I.4.4.5] “Thermal Conductivity of Gases”, Huber, Marcia L. and Allan H. Harvey, CRC Handbook of Chemistry and Physics 92 (2011).

[I.4.4.6] ASME Codes and Standards 2011, BPVC Section II, Part D.

[I.4.4.7] “MATPRO-Version 11: A Handbook of Materials Properties for Use in the Analysis of Light Water Reactor Fuel Rod Behavior”, Hagrman, D. L., Reymann, G. A., NUREG/CR-0497.

[I.4.4.8] Kern, D.Q., “Process Heat Transfer”, McGraw Hill Kogakusha (1950).

⋮

HOLTEC INTERNATIONAL COPYRIGHTED MATERIAL	
HI-2115090	Proposed Rev. 3.G
I.4-48	

SUPPLEMENT I.5: SHIELDING EVALUATION OF THE HI-STORM UMAX SYSTEM WITH 24PT1-DSC CANISTER

I.5.0 INTRODUCTION

This supplement contains a shielding evaluation of the HI-STORM UMAX VVMs loaded with 24PT1-DSCs [I.5.0.1] containing corresponding qualified fuel, pursuant to the guidelines in NUREG-1536 [5.0.1]. The objective of the analyses summarized in this chapter is to demonstrate that underground VVMs loaded with these canisters containing the corresponding qualified fuel assemblies will result in dose rates equivalent to or bounded by those presented for the MPCs in the main section of this Chapter 5, and hence provide sufficient dose blockage to enable an on-site ISFSI to be operated at a fraction of the controlled area boundary dose limits in 10CFR72.

Differences to the designs analyzed in the main section of this Chapter 5 are as follows:

- The 24PT1-DSC has a smaller diameter than the MPC-37, resulting in a larger gap between the canister enclosure shell and CEC. However, the diameter of the 24PT1-DSC is similar to that of the MPC-32 analyzed in the main section of this chapter.
- The 24PT1-DSC is shorter than the MPC-32 and the MPC-37.
- The 24PT1-DSC is only qualified for the assembly classes listed in Table I.2.1.1, and the burnup, enrichment and cooling times listed in Table I.5.0.1.

The HI-STORM UMAX VVM, with its individual components such as the CEC, divider shell and lid, to be used for the 24PT1-DSC is identical to that for the MPC-37 or MPC-89, i.e. the 24PT1-DSC can be loaded into any VVM built for any of the MPCs.

General methodologies, computer codes and acceptance criteria are identical to those used for the shielding safety analyses for the MPCs documented in the main section of this chapter.

The safety analyses for dose locations around the VVM demonstrate that the dose rates under normal conditions for a VVM loaded with the 24PT1-DSC, and using conservative modeling approached and assumption, are equivalent to, or bounded by those calculated for the MPCs. This shows that the system has sufficient shielding to ensure that under site specific conditions the controlled area dose limits specified in 10 CFR 72.104 can be met.

Note that site specific analyses need to use the site specific conditions for controlled area boundary dose calculations to show the site's compliance with 10 CFR 72.104.

Note further that as for the MPCs evaluated in the main section of this chapter, the compliance with accident dose limits in 10CFR72.106 is shown on a generic basis in Chapter 5 of HI-STORM FW FSAR [5.0.3].

HOLTEC INTERNATIONAL COPYRIGHTED MATERIAL	
HI-2115090	Proposed Rev. 3.H
I.5-1	

Table I.5.0.1			
STAINLESS STEEL CLAD FUEL BURNUP, COOLING TIME, AND ENRICHMENT FOR DOSE EVALUATION			
CANISTER TYPE	BURN- UP GWD/MTU	COOLING TIME YEARS	ENRICHMENT Wt % U-235
24PT1-DSC	45	20	3.6

HOLTEC INTERNATIONAL COPYRIGHTED MATERIAL	
HI-2115090	Proposed Rev. 3.H
I.5-2	

I.5.1 SHIELDING FEATURES, DESIGN OBJECTIVE AND RESULTS

I.5.1.1 Shielding Features

Since the system loaded with the 24PT1-DSC utilizes the same VVM, the shielding features are identical to those described for HI-STORM UMAX with MPCs in Section 5.1.1 of this chapter.

I.5.1.2 Design Objective

Design objective dose rates for the HI-STORM UMAX loaded with the 24PT1-DSC are identical to those for the system loaded with MPCs presented in Section 5.1.2 of this Chapter.

I.5.1.3 Results

Results for HI-STORM UMAX loaded with 24PT1-DSC are presented in Table I.5.1.1 and Table I.5.1.2. Figure 5.1.1 identifies the locations of the dose points referenced in Table I.5.1.1.

Comparing the results in Tables I.5.1.1 and I.5.1.2 with the results in the main section of this chapter shows that the dose rates from the HI-STORM UMAX loaded with the 24PT1-DSC are less than or show an insignificant difference as compared to HI-STORM UMAX loaded with an MPC-37 or MPC-32 (Section 5.1).

The 24PT1-DSC will be transferred into the VVM via the HI-TRAC VW transfer cask. Shielding safety analyses governing the HI-TRAC VW transfer cask are provided in Reference [5.0.3]. Since the storage dose rates with the 24PT1-DSC are bounded by the corresponding dose rates for the system loaded with an MPC, it is reasonable to expect that the same applies to the transfer with the HI-TRAC, hence results from Reference [5.0.3] are applicable to the 24PT1-DSC, and no further evaluations with the 24PT1-DSC during transfer are needed.

HOLTEC INTERNATIONAL COPYRIGHTED MATERIAL	
HI-2115090	Proposed Rev. 3.H
I.5-3	

Table I.5.1.1

[PROPRIETARY INFORMATION WITHHELD PER 10CFR2.390]

HOLTEC INTERNATIONAL COPYRIGHTED MATERIAL	
HI-2115090	Proposed Rev. 3.H
I.5-4	

Table I.5.1.2



[PROPRIETARY INFORMATION WITHHELD PER 10CFR2.390]

HOLTEC INTERNATIONAL COPYRIGHTED MATERIAL	
HI-2115090	Proposed Rev. 3.H
I.5-5	

I.5.2 SOURCE SPECIFICATION

The fuel qualified for the 24PT1-DSC is shorter and lighter than the design basis fuel characterized in Section 5.2 of this chapter, and contains either UO₂ fuel in stainless steel cladding, or MOX fuel in zircaloy cladding. Reference [I.5.0.1] indicates that the MOX fuel is bounded by the UO₂ fuel with stainless steel cladding, hence only the UO₂ fuel with stainless steel cladding is considered in the analyses presented here.

The source terms for the HI-STORM UMAX PWR design basis assemblies used in Section I.5.2 conservatively have more uranium mass than the actual shorter fuel stored in the 24PT1-DSC canister [I.5.0.1].

To simplify the evaluations, the fuel used in the shielding analyses for the 24PT1-DSC is assumed to be PWR design basis fuel as in the MPC-37, with the burnup, enrichment and cooling times listed in Table I.5.0.1, but with an addition of ⁶⁰Co from the stainless steel cladding.

I.5.2.1 Gamma Source

The fuel gamma source is presented in Table I.5.2.1. The additional source from ⁶⁰Co gammas from the stainless steel cladding and guide tubes is included in the 1.0 to 1.5 MeV energy range in Table I.5.2.1.

Table I.5.2.2 presents the ⁶⁰Co activity utilized in the shielding calculations for the non-fuel regions of the assemblies in the 24PT1-DSC analyzed within the UMAX System.

I.5.2.2 Neutron Source

The neutron source terms are listed in Tables I.5.2.3.

I.5.2.3 Non-Fuel Hardware

Non-fuel hardware allowed to be stored in UMAX System is generally discussed in Sub-section 5.2.3. The design basis assembly analyzed in Section 5.1 includes a stainless steel clad BPRAs which is determined to be bounding for all other non-fuel hardware as discussed in Paragraph 5.2.3.1. Although the 24PT1-DSC canister does not include BPRAs as allowable content, including this conservative NFH source in the 24PT1-DSC dose rate calculations (Section I.5.1) conservatively considers a greater NFH activity than what is analyzed in Section 5.2 of Reference [I.5.0.1].

I.5.2.4 Choice of Design Basis Assembly

As discussed above, the evaluations for the 24PT1-DSC conservatively use the same Westinghouse 17x17 assembly that was selected as the design basis assembly in Sub-section 5.2.4.

HOLTEC INTERNATIONAL COPYRIGHTED MATERIAL	
HI-2115090	Proposed Rev. 3.H
I.5-6	

Table I.5.2.1

[PROPRIETARY INFORMATION WITHHELD PER
10CFR2.390]

HOLTEC INTERNATIONAL COPYRIGHTED MATERIAL	
HI-2115090	Proposed Rev. 3.H
I.5-7	

Table I.5.2.2

[PROPRIETARY INFORMATION WITHHELD PER 10CFR2.390]

HOLTEC INTERNATIONAL COPYRIGHTED MATERIAL	
HI-2115090	Proposed Rev. 3.H
I.5-8	

Table I.5.2.3

[PROPRIETARY INFORMATION WITHHELD PER 10CFR2.390]

HOLTEC INTERNATIONAL COPYRIGHTED MATERIAL	
HI-2115090	Proposed Rev. 3.H
I.5-9	

I.5.3 MODEL SPECIFICATIONS

HI-STORM UMAX MCNP modeling was the same as described in section 5.3 under normal conditions with the following changes related to the 24PT1-DSC:

[

PROPRIETARY INFORMATION WITHHELD PER 10CFR2.390

]

I.5.3.1 Fuel Configuration

Fuel configuration is identical to that described in Sub-section 5.3.1. As stated above, the modeling conservatively neglects the stainless steel present in the cladding and guide tubes **Error!** **Reference source not found.**

I.5.3.2 Regional Densities

Regional densities are described in Sub-section 5.3.1.

I.5.3.3 HI-STORM UMAX Optional Features

The HI-STORM UMAX system utilizes some items with optional specifications, which are further discussed in Sub-section 5.3.3. In site specific evaluations these optional features may be credited if used.

HOLTEC INTERNATIONAL COPYRIGHTED MATERIAL	
HI-2115090	Proposed Rev. 3.H
I.5-10	

I.5.4 SHIELDING EVALUATION

Shielding analyses methodology applied to HI-STORM UMAX with 24PT1-DSC is as described in Section 5.4.

HOLTEC INTERNATIONAL COPYRIGHTED MATERIAL	
HI-2115090	Proposed Rev. 3.H
I.5-11	

I.5.5 REGULATORY COMPLIANCE

In summary it can be concluded that the shielding of the HI-STORM UMAX System with 24PT1-DSC is in compliance with 10CFR72 and satisfies the applicable design and acceptance criteria. Thus, this shielding evaluation provides reasonable assurance that the HI-STORM UMAX system with 24PT1-DSC will allow safe storage of spent fuel in full conformance with 10CFR72.

HOLTEC INTERNATIONAL COPYRIGHTED MATERIAL	
HI-2115090	Proposed Rev. <u>3.H</u>
I.5-12	

5.6 REFERENCES

- [I.5.0.1] [AREVA Inc. \(formerly Transnuclear, Inc.\), “Updated Final Safety Analysis Report for the Standardized Advanced NUHOMS Horizontal Modular Storage System for Irradiated Nuclear Fuel Report No. ANUH 01.0150”, Revision 6 \(Non-Proprietary Version\), Docket 72-1029, August 2014. Compiled from ML050410252, ML031040379, ML031040312, ML040910311, ML082341022, ML102290084, ML12229A121, and ML14226A790.](#)

HOLTEC INTERNATIONAL COPYRIGHTED MATERIAL	
HI-2115090	Proposed Rev. 3.H
I.5-13	

SUPPLEMENT I.6: CRITICALITY EVALUATION

I.6.0 INTRODUCTION

This supplement to Chapter 6 presents the criticality safety evaluation of the HI-STORM UMAX system loaded with the 24PT1-DSC canister. The evaluation shows that the maximum k_{eff} value, including all applicable biases and uncertainties is below 0.95 for all normal, off-normal and accident conditions.

The initial criticality safety evaluation of the 24PT1-DSC canister, with the canister either residing in the NUHOMS-MP187 transfer cask or the Standardized Advanced NUHOMS modules (AHSMs) under both wet and dry conditions, is documented in Chapter 6 of the Standardized Advanced NUHOMS FSAR [I.1.2.1].

Since there are no wet conditions during the operation of HI-STORM UMAX with the 24PT1-DSC canister (no canister loading / unloading), the canister will always be internally dry, hence criticality safety is demonstrated in this supplement for 24PT1-DSC in the HI-TRAC VW and HI-STORM UMAX under dry conditions only, and without any reference to evaluations in [I.1.2.1].

In the calculations presented here, only the assemblies are considered to be present inside the canister. All other materials, i.e. the basket including the neutron absorber, are neglected. This is conservative, resulting in an upper-bound multiplication factor due to neglecting all neutron-absorbing materials. This also avoids the need to specify any design details of those parts. Despite this extreme conservatism, the maximum k_{eff} of the system remains well below the regulatory limit, due to the absence of water in the canister. This provides a substantial margin to the acceptance criteria that would be available to offset any uncertainties not explicitly considered in the analyses presented here.

Apart from this simplifying and conservative assumption, analysis methodologies and modeling assumptions utilized in the evaluation documented in this supplement are based on those used in the licensing of HI-STORM FW in Docket #72-1032 [2.0.1]. For clarity, Table I.6.0.1 below identifies the information incorporated by reference in this supplement, the source of the information, a reference to the NRC approval of the information (SER), where in this supplement it is incorporated, and a discussion of the applicability of the previously approved information.

HOLTEC INTERNATIONAL COPYRIGHTED MATERIAL	
HI-2115090	Proposed Rev. 3.F
I.6-1	
142 of 282	

Table I.6.0.1: Material Incorporated by Reference

Information Incorporated by Reference	Source of the Information	NRC Approval of Material Incorporated by Reference	Location in this FSAR where Material is Incorporated	Technical Justification of Applicability to HI-STORM UMAX
General Criticality Discussions for Holtec Systems	Section 6.1, Reference [2.0.1];	SER HI-STORM FW Amendment 0, Reference [I.1.2.3];	I.6.1	In general, methodology and assumptions for criticality safety evaluations are the same as that used for the HI-STORM FW, including codes used for the analyses.
HI-TRAC VW design	Section 1.2.1.3 Reference [2.0.1]	SER HI-STORM FW Amendment 0, Reference [I.1.2.3]	I.6.3	The HI-TRAC VW used with the 24PT1-DSC is the same as the one originally approved in the referenced SER.
Materials and Cross Section Sets	Section 6.3.2, Reference [2.0.1];	SER HI-STORM FW Amendment 0, Reference [I.1.2.3];	I.6.3.2	Same materials and cross section sets used here.
Methodology	Sections 6.4.1, 6.4.3 and 6.5, Reference [2.0.1];	SER HI-STORM FW Amendment 0, Reference [I.1.2.3];	I.6.4.1, I.6.4.4, I.6.5	In general, methodology and assumptions for criticality safety evaluations are the same as that used for the HI-STORM FW, including codes used for the analyses.

HOLTEC INTERNATIONAL COPYRIGHTED MATERIAL

HI-2115090

Proposed Rev. 3.F

I.6-2

143 of 282

I.6.1 DISCUSSION AND RESULTS

The results in this chapter demonstrate that the effective multiplication factor (k_{eff}) of the HI-STORM UMAX system loaded with the 24PT1-DSC, including all biases and uncertainties evaluated with a 95% probability at the 95% confidence level, does not exceed 0.95 under all credible normal, off-normal, and accident conditions. The results demonstrate that at least two unlikely, independent, and concurrent or sequential changes must occur to the conditions essential to criticality safety before a nuclear criticality accident is possible. These criteria provide a large subcritical margin, sufficient to assure the criticality safety of the HI-STORM UMAX system when loaded with the 24PT1-DSC.

The acceptance criteria for criticality evaluations for the HI-STORM UMAX system loaded with the 24PT1-DSC canister are presented in Subsection I.2.0 of this FSAR. Those are identical to the acceptance criteria for criticality evaluations for all other canisters loaded into the HI-STORM UMAX system.

During storage conditions in the HI-STORM UMAX system, the maximum k_{eff} will be significantly below the regulatory limit since the canister is internally dry. This results in a large margin to acceptance criteria.

To assure the true reactivity will always be less than the calculated reactivity, the following conservative design criteria and assumptions were made:

[

PROPRIETARY INFORMATION WITHHELD PER 10CFR2.390

]

HOLTEC INTERNATIONAL COPYRIGHTED MATERIAL	
HI-2115090	Proposed Rev. 3.F
I.6-3 144 of 282	

The off-normal and accident conditions defined in Supplement I.2 and considered in Supplement I.12 have no adverse effect on the design parameters important to criticality safety and thus, from the criticality safety standpoint, the off-normal and accident conditions are identical to those for normal conditions.

For additional details and justifications, the reader is referred to Section 6.1 of the HI-STORM FW FSAR [2.0.1].

The design basis criticality safety calculations are performed for the internally dry HI-TRAC VW and HI-STORM UMAX (limiting case for the HI-STORM UMAX system with the 24PT1-DSC canister), and include the calculational bias, uncertainties, and calculational statistics.

The calculations in this supplement use the same computer code, cross-section library and methodologies that are used in the HI-STORM FW FSAR [2.0.1], hence the benchmark calculations, and specifically the bias and bias uncertainty remain applicable. The results are listed in Table I.6.1.1 and confirm that the maximum k_{eff} values for the HI-STORM UMAX system with the 24PT1-DSC canister under storage conditions (dry inert environment) is substantially below the limiting design criteria ($k_{\text{eff}} < 0.95$). Analyses for various conditions of external flooding are presented in Subsection I.6.4.4 to establish the bounding condition with respect to the external flooding.

HOLTEC INTERNATIONAL COPYRIGHTED MATERIAL	
HI-2115090	Proposed Rev. 3.F
I.6-4	
Hi-STORM UMAX Supplement I Rev 3f	145 of 282

TABLE I.6.1.1

MAXIMUM K_{eff} VALUES FOR THE HI-STORM UMAX SYSTEM WITH THE 24PT1-DSC

Overpack/Module	Maximum k_{eff}^1
HI-TRAC VW	0.5559
HI-STORM UMAX	0.4742

¹ Includes bias, bias uncertainties, and calculational statistics.

HOLTEC INTERNATIONAL COPYRIGHTED MATERIAL	
HI-2115090	Proposed Rev. 3.F
I.6-5	

I.6.2 SPENT FUEL LOADING

The 24PT1-DSC canister is only qualified for the two assembly types specified in Table I.2.1.1. The analyses explicitly model those types, applying several conservative assumptions as discussed in Section I.6.1.

HOLTEC INTERNATIONAL COPYRIGHTED MATERIAL	
HI-2115090	Proposed Rev. 3.F
I.6-6	
147 of 282	

I.6.3 MODEL SPECIFICATION

I.6.3.1 Description of Calculational Model

Figures I.6.3.1 through I.6.3.4 show cross sections of the criticality models. Figures I.6.3.1 and I.6.3.2 show the planar cross-section of HI-TRAC VW and HI-STORM UMAX overpack/module models, respectively, whereas Figures I.6.3.3 and I.6.3.4 show the axial cross-section of HI-TRAC VW and HI-STORM UMAX overpack/module models, respectively. Relevant dimensions of the modeled canister and overpacks are summarized in Tables I.6.3.2 and I.6.3.3. The bases for the dimensions are as follows:

[

PROPRIETARY INFORMATION WITHHELD PER 10CFR2.390

]

I.6.3.2 Cask Regional Densities

Compositions of the various components used in the calculations are listed in Table 6.3.4 of the HI-STORM FW FSAR [2.0.1] and repeated here in Table I.6.3.1. The cross section set for each nuclide is listed in Table 6.3.8 of the HI-STORM FW FSAR [2.0.1], and is consistent with the cross section sets used in the benchmarking calculations documented in Appendix A of the HI-STORM FW FSAR [2.0.1]. Note that these are the default cross sections chosen by the code.

HOLTEC INTERNATIONAL COPYRIGHTED MATERIAL	
HI-2115090	Proposed Rev. 3.F
I.6-7 148 of 282	

TABLE I.6.3.1

[PROPRIETARY INFORMATION WITHHELD PER 10CFR2.390]

HOLTEC INTERNATIONAL COPYRIGHTED MATERIAL	
HI-2115090	Proposed Rev. 3.F
I.6-8	
Hi-STORM UMAX Supplement I Rev 3f	149 of 282

TABLE I.6.3.2

[PROPRIETARY INFORMATION WITHHELD PER 10CFR2.390]

HOLTEC INTERNATIONAL COPYRIGHTED MATERIAL	
HI-2115090	Proposed Rev. 3.F
I.6-9	
Hi-STORM UMAX Supplement I Rev 3f	150 of 202

TABLE I.6.3.3

[PROPRIETARY INFORMATION WITHHELD PER 10CFR2.390]

HOLTEC INTERNATIONAL COPYRIGHTED MATERIAL	
HI-2115090	Proposed Rev. 3.F
I.6-10	

TABLE I.6.3.3 (continued)
[PROPRIETARY INFORMATION WITHHELD PER 10CFR2.390]

HOLTEC INTERNATIONAL COPYRIGHTED MATERIAL	
HI-2115090	Proposed Rev. 3.F
I.6-11	
Hi-STORM UMAX Supplement 1 Rev 3f	152 of 282

[PROPRIETARY INFORMATION WITHHELD PER 10CFR2.390]

Figure I.6.3.1: Calculational Model (planar cross-section) of HI-TRAC VW

HOLTEC INTERNATIONAL COPYRIGHTED MATERIAL	
HI-2115090	Proposed Rev. 3.F
I.6-12	

[PROPRIETARY INFORMATION WITHHELD PER 10CFR2.390]

Figure I.6.3.2: Calculational Model (planar cross-section) of HI-STORM UMAX

HOLTEC INTERNATIONAL COPYRIGHTED MATERIAL	
HI-2115090	Proposed Rev. 3.F
I.6-13	

[PROPRIETARY INFORMATION WITHHELD PER 10CFR2.390]

Figure I.6.3.3: Calculational Model (axial cross-section) of HI-TRAC VW

HOLTEC INTERNATIONAL COPYRIGHTED MATERIAL	
HI-2115090	Proposed Rev. 3.F
I.6-14	
Hi-STORM UMAX Supplement 1 Rev 3f	155 of 262

[PROPRIETARY INFORMATION WITHHELD PER 10CFR2.390]

Figure I.6.3.4: Calculational Model (axial cross-section) of HI-STORM UMAX

HOLTEC INTERNATIONAL COPYRIGHTED MATERIAL	
HI-2115090	Proposed Rev. 3.F
I.6-15	

[PROPRIETARY INFORMATION WITHHELD PER 10CFR2.390]

HOLTEC INTERNATIONAL COPYRIGHTED MATERIAL	
HI-2115090	Proposed Rev. 3.F
Hi-STORM UMAX Supplement I Rev 3I April 2020	I.6-17 158 of 282

TABLE I.6.4.1

[PROPRIETARY INFORMATION WITHHELD PER 10CFR2.390]

HOLTEC INTERNATIONAL COPYRIGHTED MATERIAL	
HI-2115090	Proposed Rev. 3.F
I.6-18	
Hi-STORM UMAX Supplement 1 Rev 3f	159 of 262

I.6.5 CRITICALITY BENCHMARK EXPERIMENTS

The calculations in this supplement use the same computer code, cross-section library and methodologies that are used in the HI-STORM FW FSAR [2.0.1], hence the benchmark calculations, and specifically the bias and bias uncertainty remain applicable. The reader is referred to Section 6.5 of the HI-STORM FW FSAR [2.0.1] for a comprehensive discussion of the benchmarking.

HOLTEC INTERNATIONAL COPYRIGHTED MATERIAL	
HI-2115090	Proposed Rev. 3.F
Hi-STORM UMAX Supplement I Rev 3f	I.6-19 160 of 282

I.6.6 REGULATORY COMPLIANCE

This section documents the criticality evaluation of the HI-STORM UMAX system for the storage of spent nuclear fuel in the 24PT1-DSC canister. This evaluation demonstrates that the HI-STORM UMAX system is in full compliance with the criticality requirements of 10CFR72 and NUREG-1536.

Structures, systems, and components important to criticality safety, as well as the limiting fuel characteristics, are either described in sufficient detail in this chapter or provided with a reference on the HI-STORM FW and/or HI-STORM 100 FSARs to enable an evaluation of their effectiveness.

Criticality safety of the 24PT1-DSC canister in the NUHOMS-MP187 transfer cask and the Standardized Advanced NUHOMS modules (AHSMs) under both wet and dry conditions is demonstrated by criticality evaluations documented in Chapter 6 of the Standardized Advanced NUHOMS FSAR [I.1.2.1].

Since there are no wet conditions during the operation of HI-STORM UMAX with the 24PT1-DSC canister (no canister loading / unloading), criticality safety is demonstrated in this supplement for 24PT1-DSC in the HI-TRAC VW and HI-STORM UMAX under dry conditions only. The results confirm that the maximum k_{eff} values for the HI-STORM UMAX system with the 24PT1-DSC canister under storage conditions (dry inert environment) is substantially below the limiting design criteria ($k_{eff} < 0.95$).

Therefore, it is concluded that the criticality design features for the HI-STORM UMAX system are in compliance with 10 CFR Part 72 and that the applicable design and acceptance criteria have been satisfied. The criticality evaluation provides reasonable assurance that the HI-STORM UMAX system will allow safe storage of spent fuel.

HOLTEC INTERNATIONAL COPYRIGHTED MATERIAL	
HI-2115090	Proposed Rev. 3.F
I.6-20 161 of 262	
Hi-STORM UMAX Supplement I Rev 3f April 2020	

SUPPLEMENT I.7: CONFINEMENT EVALUATION¹

I.7.0 INTRODUCTION

This supplement discusses confinement safety of the HI-STORM UMAX System, when loaded with a 24PT1-DSC. Confinement of all radioactive materials in the HI-STORM UMAX system is provided by the loaded canister, in this supplement the 24PT1-DSC. The confinement boundary for the 24PT1-DSC consists of a cylindrical shell, and the top and bottom cover plate assemblies, and associated welds. A detailed drawing of the containment boundary is provided in Figure 7.1-1 of the Standardized Advanced NUHOMS System FSAR [I.1.2.1]. The confinement boundary of the 24PT1-DSC complies with the “leaktight” criterion established in ANSI N14.5 [I.2.2.3] during normal, off-normal and hypothetical accident conditions. There are no credible accidents which could breach the confinement boundary of the 24PT1-DSC. Table I.7.0.1 contains material incorporated by reference in this supplement.

All normal, off-normal and accident conditions relevant for confinement are identical between the HI-STORM UMAX System loaded with a 24PT1-DSC and the HI-STORM UMAX system analyzed in the main body of this FSAR, and there are no new conditions for the HI-STORM UMAX System that would require additional confinement analyses. Therefore, since the 24PT1-DSC and its contents are approved for storage in the Standardized Advanced NUHOMS System [Docket No. 72-1029], the confinement leaktight criterion under normal, off-normal and accident conditions for the 24PT1-DSC in Chapter 7 of the Standardized Advanced NUHOMS System FSAR remains applicable to the HI-STORM UMAX loaded with a 24PT1-DSC. Confinement safety of the HI-STORM UMAX loaded with the 24PT1-DSC is therefore demonstrated in this supplement by reference to Supplement I.2 and I.11 of this FSAR and Chapters 7 and 11 of the Standardized Advanced NUHOMS System FSAR [I.1.2.1].

I.7.1 ACCEPTANCE CRITERIA

The acceptance criteria for confinement evaluations for the HI-STORM UMAX system are presented in Supplement I.2 of this FSAR. Additionally, to be consistent with NRC approved license periods for canister designs, the time frame between initial loading of the 24PT1-DSC canisters and placement in the HI-STORM UMAX at the ISFSI Pad shall be less than or equal to 20 years. This eliminates the need for aging management programs for confinement integrity. The canister will not be transported off-site, so there are no concerns with regard to challenges to its confinement integrity.

¹ Supplement I adds the 24PT1-DSC canister to the HI-STORM UMAX system. Only those design features, analyses and evaluations of “UMAX” that are revised or added to incorporate the 24PT1-DSC canister are described in this chapter. This chapter also references to the main body of the FSAR where existing safety analyses are bounding, as applicable.

HOLTEC INTERNATIONAL COPYRIGHTED MATERIAL	
HI-2115090	Proposed Rev. 3.E
I.7-1	

I.7.2 EVALUATION

The 24PT1-DSC will be stored in the HI-STORM UMAX VVM in a passive state just as they are stored in the above ground overpacks described in the Standardized Advanced NUHOMS System FSAR. Furthermore, as shown in Chapter 4, the temperature field in the loaded 24PT1-DSC, when stored inside the HI-STORM UMAX VVM, is bounded by that determined for storage in the Standardized Advanced NUHOMS System FSAR. Therefore, the stress levels in the canister pressure retaining boundary will be bounded by that in its certification basis value in the Standardized Advanced NUHOMS System FSAR which leads to the axiomatic conclusion that the confinement integrity determinations reached for the Standardized Advanced NUHOMS System bound, and therefore apply to storage in the HI-STORM UMAX System.

In summary, the storage configuration of 24PT1-DSC in HI-STORM UMAX is identical to the storage configuration in the Standardized Advanced NUHOMS System from a confinement perspective. Therefore, all descriptions and conclusions for the confinement system presented in Chapter 7 of the Standardized Advanced NUHOMS System FSAR remain applicable to the HI-STORM UMAX system, and no additional confinement evaluations are required. These evaluations conclude that confinement is maintained under all normal, off-normal and accident conditions.

HOLTEC INTERNATIONAL COPYRIGHTED MATERIAL	
HI-2115090	Proposed Rev. 3.E
I.7-2	

Table I.7.0.1: Material Incorporated by Reference from [I.1.2.1] and [I.1.2.2]

Information Incorporated by Reference	Source of the Information	NRC Approval of Material Incorporated by Reference	Location in this FSAR where Material is Incorporated	Technical Justification of Applicability to HI-STORM UMAX
Canister Description	Section 1.2 of Reference [I.1.2.2]	SER Advanced NUHOMS Amendment 0, Reference [I.1.2.2]	I.7.0	The canister is the same as the one described in the FSAR and originally approved in the referenced SER.
24PT1-DSC Figure	Figure 7.1-1 of Reference [I.1.2.1]	Standardized Advanced NUHOMS FSAR, Revision 6 [I.1.2.1]	I.7.0 I.7.2	A detailed, complete and approved drawing of the canister is provided in the NUHOMS FSAR in NRC Docket 72-1029. The canister requested for storage in the UMAX in this supplement is same as the canister described in the referenced FSAR.
Confinement Evaluation for 24PT1-DSC	Chapter 7 of Reference [I.1.2.1]	Standardized Advanced NUHOMS FSAR, Revision 6 [I.1.2.1]	I.7.2	Confinement evaluation for the 24PT1-DSC in the Standardized Advanced NUHOMS FSAR is applicable to the confinement evaluation in this supplement.

HOLTEC INTERNATIONAL COPYRIGHTED MATERIAL

HI-2115090

Proposed Rev. 3.E

I.7-3

SUPPLEMENT I.8: MATERIAL EVALUATION OF 24PT1-DSC CANISTER

I.8.0 GENERAL INFORMATION

Supplement I of this FSAR adds the 24PT1-DSC canister described in reference [I.1.2.1] to a HI-STORM UMAX system.

A modified HI-STORM UMAX is used with 24PT1-DSC canister for long-term storage as described in Supplements I.1 and I.7. The design features of the HI-STORM UMAX VVM that are revised or added to interface with the 24PT1-DSC canister are in the scope of the material evaluation presented in this supplement. In addition, the material evaluation of the 24PT1-DSC canister, not already provided in the referenced document(s) in Table I.8.0.1, are in the scope of this supplement. Finally, interfacing features between the VVM and the 24PT1-DSC canister are also treated in this supplement for completeness of the material evaluation.

HI-TRAC VW and HI-STORM UMAX are used with a Canister Handling Apparatus (CHA) for short-term operations as described in Supplements I.1 and I.7. The material evaluation of the HI-TRAC VW for use with MPCs is provided in Chapter 8 of the HI-STORM FW as indicated in Table I.8.0.1 and table in Section 8.1 of this FSAR. The material evaluation of the CHA is in the scope of the material evaluation presented in this supplement. In addition, the interfacing features between the CHA and the HI-TRAC, the CHA and the VVM and the CHA and the 24PT1-DSC canister are also treated in this supplement for completeness of the material evaluation.

This supplement refers to the main body of the FSAR where existing safety analyses are bounding, as applicable. Table I.8.0.1 identifies the 24PT1-DSC canister information incorporated by reference, the source of the information, a reference to the NRC approval of the information (viz. SER), where in this supplement it is incorporated, and a discussion of the applicability of the previously approved information.

The material in this supplement is organized to mirror the corresponding material in the main body of the FSAR with the letter I. inserted before each chapter/section/subsection/paragraph number. Thus the numeric sequence I.m.n.p.r indicates that the material belongs to Supplement I, Chapter #m, Section #n, sub-section #p and paragraph #r. (m, n, p and r are numeric values). Thus, the numbering of the material in the supplement is readily distinguished from the main FSAR's while the content correspondence is maintained.

HOLTEC INTERNATIONAL COPYRIGHTED MATERIAL	
HI-2115090	Proposed Rev. 3.E
I.8-1	

Table I.8.0.1: Material Incorporated by Reference

Information Incorporated by Reference	Source of the Information	NRC Approval of Material Incorporated by Reference	Location in this FSAR where Material is Incorporated	Technical Justification of Applicability to HI-STORM UMAX
24PT1-DSC Material Evaluation	Reference [I.1.2.1]	SER Advanced NUHOMS Amendment 0, Reference [I.1.2.2]	I.8.2	The canister is the same as the one described in the Advanced NUHOMS FSAR and originally approved in the referenced SER.
24PT1-DSC Codes and Standards	Reference [I.1.2.1]	SER Advanced NUHOMS Amendment 0, Reference [I.1.2.2]	I.8.3	The canister is the same as the one described in the Advanced NUHOMS FSAR and originally approved in the referenced SER.
24PT1-DSC Material Properties	Reference [I.1.2.1]	SER Advanced NUHOMS Amendment 0, Reference [I.1.2.2]	I.8.4	The canister is the same as the one described in the Advanced NUHOMS FSAR and originally approved in the referenced SER.
24PT1-DSC Lowest Service Temperature for Handling Operations	Reference [I.1.2.1]	SER Advanced NUHOMS Amendment 0, Reference [I.1.2.2]	I.8.4	The canister is the same as the one described in the Advanced NUHOMS FSAR and originally approved in the referenced SER.
24PT1-DSC Minimum Storage Life	Reference [I.1.2.1]	SER Advanced NUHOMS Amendment 0, Reference [I.1.2.2]	I.8.4	The canister is the same as the one described in the Advanced NUHOMS FSAR and originally approved in the referenced SER.
24PT1-DSC Chemical and Galvanic Reactions	Reference [I.1.2.1]	SER Advanced NUHOMS Amendment 0, Reference [I.1.2.2]	I.8.4	The canister is the same as the one described in the Advanced NUHOMS FSAR and originally approved in the referenced SER.

HOLTEC INTERNATIONAL COPYRIGHTED MATERIAL

HI-2115090

Proposed Rev. 3.E

I.8-2

24PT1-DSC Welding and Welding Material Specifications	Reference [I.1.2.1]	SER Advanced NUHOMS Amendment 0, Reference [I.1.2.2]	I.8.5	The canister is the same as the one described in the Advanced NUHOMS FSAR and originally approved in the referenced SER.
24PT1-DSC Fuel Cladding Integrity	Reference [I.1.2.1]	SER Advanced NUHOMS Amendment 0, Reference [I.1.2.2]	I.8.12	The canister is the same as the one described in the Advanced NUHOMS FSAR and originally approved in the referenced SER.
24PT1-DSC Helium Leak Testing	Reference [I.1.2.1]	SER Advanced NUHOMS Amendment 0, Reference [I.1.2.2]	I.8.12	The canister is the same as the one described in the Advanced NUHOMS FSAR and originally approved in the referenced SER.
HI-TRAC VW Material Evaluation	Revision 3 of Reference [I.1.2.3]	SER HI-STORM FW Amendment 0, Reference [I.1.2.3]	I.8.0	The HI-TRAC VW is the same as the one originally approved in the referenced HI-STORM FW SER.
HI-TRAC VW Coating and Corrosion Mitigation	Revision 3 of Reference [I.1.2.3]	SER HI-STORM FW Amendment 0, Reference [I.1.2.3]	I.8.7	The HI-TRAC VW is the same as the one originally approved in the referenced HI-STORM FW SER.

HOLTEC INTERNATIONAL COPYRIGHTED MATERIAL	
HI-2115090	Proposed Rev. 3.E
I.8-3	

I.8.1 INTRODUCTION

This supplement presents an assessment of the materials selected for use of the 24PT1-DSC canister in a modified HI-STORM UMAX VVM. The generic design of the HI-STORM UMAX VVM is provided in the drawing package in Section 1.5 and described and evaluated in the main body of this FSAR. The materials evaluation of the generic HI-STORM UMAX VVM with generic HI-STORM FW MPCs is presented in the main body of Chapter 8. Additional materials evaluation of the modifications to the HI-STORM UMAX VVM is provided in this supplement as required. The materials evaluation of the 24PT1-DSC canister with the Advanced NUHOMS system (also a ventilated storage system) is presented in NUHOMS FSAR [I.1.2.1] as indicated in Table I.8.0.1. The information on the material evaluation of the MPCs in the main body of Chapter 8 is applicable to the 24PT1-DSC unless otherwise discussed in this supplement; however, additional materials evaluation of the 24PT1-DSC canister is provided in this supplement as required for implementation of the 24PT1-DSC canister in the HI-STORM UMAX VVM.

HI-STORM UMAX VVM modifications necessary to implement the 24PT1-DSC canister are shown in the drawing package in Section I.1.5 and described and evaluated in Supplement I of this FSAR. HI-STORM UMAX VVM modifications include the following design features:

[
 PROPRIETARY INFORMATION WITHHELD PER 10CFR2.390
]

This supplement also presents an assessment of the materials selected for use of the CHA along with an assessment of the following component interfaces:

- 1) 24PT1-DSC canister and HI-TRAC VW
- 2) CHA and 24PT1-DSC canister
- 3) CHA and HI-TRAC VW
- 4) CHA and HI-STORM UMAX VVM

The material evaluation presented in this supplement is mainly focused towards the long-term storage of the previously licensed 24PT1-DSC canister in the VVM and its consequences to the system's continued safety with consideration to license life, design life and service life as discussed in Supplement I.1. More importantly the 24PT1-DSC canister is restricted to a total long-term storage duration not exceeding its original license life of 20 years. Thus 24PT1-DSC canisters already in storage under Docket No. 72-1029 for 20 years or greater are not qualified to be stored in the HI-STORM UMAX. The 24PT1-DSC canister shall have been loaded, sealed, and dried in accordance with Advanced NUHOMS CoC 72-1029.

The material evaluation provided in this supplement takes into consideration the design description and allowable contents provided in Supplement I.1, the principal design criteria provided in Supplement I.2 and the essential operations provided in Supplement I.7, the system performance characteristics as evaluated in Supplements I.3, I.4, I.5, I.6 and I.7 and acceptance

HOLTEC INTERNATIONAL COPYRIGHTED MATERIAL	
HI-2115090	Proposed Rev. 3.E
I.8-4	

criteria and maintenance program presented in Supplement I.10. The ITS categories of the principal materials of construction of TSRA, DSA, HI-STORM UMAX – 24PT1-DSC Pedestal, and CHA are provided in the drawings in Supplement I.1.

The information compiled in this supplement seeks to address ISG-15 acceptance criteria for material evaluation as presented in Section 8.1 of this FSAR.

HOLTEC INTERNATIONAL COPYRIGHTED MATERIAL	
HI-2115090	Proposed Rev. 3.E
I.8-5	

I.8.2 MATERIAL SELECTION

The acceptance criteria for the materials subject to long-term conditions in the modified HI-STORM UMAX depicted in the drawing package in Supplement I.1 is specified in Section 8.2 of this FSAR.

I.8.2.1 Structural Materials

I.8.2.1.1 Cask Components and Their Constituent Materials

The discussion presented in paragraph 8.2.1.1 is applicable to the modified HI-STORM UMAX VVM depicted in Supplement I.1. The TSRA, DSA and the Pedestal are structural design features made from steels previously approved for such applications.

The 24PT1-DSC canister is an all-welded Type 316 austenitic stainless steel pressure vessel with the following structural components as discussed in reference [I.1.2.1] and reference [I.1.2.2].

- 1) For the canister shell
 - a) shell cylinder (Type 316 stainless steel)
 - b) shield plugs (A36 steel)
 - c) shell end cover plates (Type 316 stainless steel)
- 2) For the canister internals or basket assembly
 - a) support rods (steel)
 - b) spacer discs (carbon steel)
 - c) guide sleeves (stainless steel)

The pressure vessel is designed by analysis to meet the stress intensity allowables of the ASME Boiler and Pressure Vessel Code, Section III, Division I, Subsection NB as further specified in reference [I.1.2.1] as indicated in Table I.8.0.1. The thickness of the canister shell is 5/8 inch. The stainless steels in the 24PT1-DSC canister were chosen for increased corrosion resistance in marine environments. All non-pressure boundary components welded to the pressure boundary are also stainless steel. An evaluation of chemical and galvanic reactions is provided in Section 3.4 of reference [I.1.2.1] as indicated in Table I.8.0.1. These structural components have been qualified for both long-term storage and transportation conditions and therefore merit no further material evaluation in this FSAR.

CHA-90 is a structural lifting and handling ancillary with important to safety structural components made from ASME or ASTM steels or stainless steels and Nitronic 60. Bolts are alloy steel while nuts are carbon steel. CHA-90 is made from steels and stainless steels previously approved for such applications. The applicable codes and standards for CHA-90 materials are provided in the drawing package in Section I.1.5 and Supplement I.10.

HOLTEC INTERNATIONAL COPYRIGHTED MATERIAL	
HI-2115090	Proposed Rev. 3.E
I.8-6	

I.8.2.1.2 Synopsis of Structural Materials

i. Carbon Steel, Low-Alloy Steel, and Nickel Alloy Steel

Carbon steels and low-alloy steels are used for structural function (and in some cases double as shielding function) throughout the HI-STORM UMAX VVM as discussed in the main body of Chapter 8.

The TSRA (with TSRA Support Lugs) and the DSA perform a structural function (seismic restraint); therefore, the major components are heavy structural important to safety members made from carbon steels and/or low alloy steels, typically A36 or equivalent. The TSRA and DSA essentially replace the Upper MPC Guides located on the VVM Divider Shell. The TSRA Top Shield Ring carries relatively low loads (of lesser structural importance) but also performs a shielding function. The TSRA Support Lugs maintain the TSRA Top Shield Ring at a specified elevation to ensure unrestricted flow of the heated exit air.

The VVM Pedestal is an all carbon steel/low alloy important to safety weldment that is welded of the top of the VVM CEC Baseplate. It performs the structural function of bearing the full weight of the loaded 24PT1-DSC. Loads are transmitted through the Pedestal Top Plate, Pedestal Legs and the Center Support directly to the VVM’s CEC Baseplate.

The main purpose of the CHA-90 is for handling and lifting of the loaded and sealed 24PT1-DSC canister. The CHA-90 interfaces with the HI-TRAC VW and the HI-STORM UMAX VVM. The major structural important to safety components and their materials of construction are the following (two configurations are provided):

[

PROPRIETARY INFORMATION WITHHELD PER 10CFR2.390

]

HOLTEC INTERNATIONAL COPYRIGHTED MATERIAL	
HI-2115090	Proposed Rev. 3.E
I.8-7	

[

PROPRIETARY INFORMATION WITHHELD PER 10CFR2.390

]

All of the materials of construction used for the structural components of the above equipment have been previously used in dry storage and transport applications.

ii. Reinforced Concrete

There are no changes to the reinforced concrete in the HI-STORM UMAX ISFSI described in Chapter 8 of this FSAR. Component temperatures of HI-STORM UMAX with 24PT1-DSC are bounded by component temperatures reported Chapter 3 of this FSAR; therefore the reinforced concrete does not require further evaluation.

iii. Self-hardening Engineered Subgrade

There are no changes to the self-hardening engineered subgrade in the HI-STORM UMAX ISFSI described in Chapter 8 of this FSAR.

iv. Austenitic Stainless Steel

There are no changes to the austenitic stainless steels in the HI-STORM UMAX ISFSI described in Chapter 8 of this FSAR.

The Type 316 austenitic stainless steel used for structural components of the 24PT1-DSC has been previously qualified for both long-term storage (10CFR72) and transportation (10CFR71) conditions.

I.8.2.2 Non-Structural Materials

i. Plain Concrete

There are no changes to the plain concrete in the VVM Closure Lid, VVM CEC encasement, and structural subgrade below the ISFSI Pad described in Chapter 8 of this FSAR.

HOLTEC INTERNATIONAL COPYRIGHTED MATERIAL	
HI-2115090	Proposed Rev. 3.E
I.8-8	

Component temperatures of HI-STORM UMAX with 24PT1-DSC are bounded by component temperatures reported Chapter 3 of this FSAR; therefore the plain concrete does not require further evaluation.

ii. Insulation

There are no changes to the insulation surrounding the VVM Divider Shell as described in Chapter 8 of this FSAR. Component temperatures of HI-STORM UMAX with 24PT1-DSC are bounded by component temperatures reported in Chapter 5 of this FSAR; therefore the insulation does not require further evaluation. Furthermore the radiation field of the HI-STORM UMAX with 24PT1-DSC is bounded by the radiation field as described in Chapter 5 of this FSAR; therefore the insulation does not require further evaluation.

iii. Boral™

Boral™ is the neutron absorber placed between fuel assemblies in the 24PT1-DSC for criticality control. Boral™ is non-structural and manufactured with an aluminum clad Boron Carbide matrix and is on the order of 0.2 inches thick. Boral™ is exposed to borated water during in-pool loading and unloading operations; however, the duration of these operations are short-term. During storage, the cavity is dry and sealed from the environment. An evaluation of chemical and galvanic reactions is provided in Section 3.4 of reference [I.1.2.1] as indicated in Table I.8.0.1. Boral™ has been extensively qualified for use in other storage (HI-STORM 100 Docket No. 72-1014 and HI-STAR 100 Docket No. 72-1008) and transportation (HI-STAR 100 Docket No. 71.-9261) casks as well as for use in spent fuel pool storage racks; therefore, Boral™ merit no further material evaluation in this FSAR.

I.8.2.3 Critical Characteristics and Equivalent Materials

Except for the 24PT1-DSC canister, which is not fabricated by Holtec International, the discussion in Subsection 8.2.3 of this FSAR is applicable to the modified HI-STORM UMAX System presented in Supplement I of this FSAR.

HOLTEC INTERNATIONAL COPYRIGHTED MATERIAL	
HI-2115090	Proposed Rev. 3.E
I.8-9	

I.8.3 APPLICABLE CODES AND STANDARDS

The discussion in Section 8.3 of this FSAR is applicable to the modified HI-STORM UMAX VVM presented in Supplement I of this FSAR.

The CHA-90 is designed as a special lifting device per NUREG-0612 and ANSI N14.6 as specified in Supplement I.10. The applicable codes and standards of CHA-90 are provided in the drawing package in Section I.1.5 and Supplement I.10.

The applicable codes and standards of the 24PT1-DSC canister are provided in reference [I.1.2.1] as indicated in Table I.8.0.1.

HOLTEC INTERNATIONAL COPYRIGHTED MATERIAL	
HI-2115090	Proposed Rev. 3.E
I.8-10	

I.8.4 MATERIAL PROPERTIES

The discussion in Section 8.4 of this FSAR is applicable to the modified HI-STORM UMAX VVM presented in Supplement I of this FSAR.

Material properties of the 24PT1-DSC canister are provided in reference [I.1.2.1] as indicated in Table I.8.0.1.

I.8.4.1 Mechanical Properties

Mechanical properties of the modified HI-STORM UMAX VVM and CHA-90 can be found in Sections 3.3 and I.3.3. Mechanical properties of the 24PT1-DSC canister are provided in reference [I.1.2.1] as indicated in Table I.8.0.1.

I.8.4.2 Thermal Properties

Thermal properties of the modified HI-STORM UMAX VVM and CHA-90 can be found in Sections 4.2 and I.4.2. Thermal properties of the 24PT1-DSC canister and stored spent fuel cladding are provided in reference [I.1.2.1] as indicated in Table I.8.0.1 and Section I.4.2 of this FSAR.

I.8.4.3 Low Temperature Ductility of Ferritic Steels

The discussion in Subsection 8.4.3 of this FSAR is applicable to the modified HI-STORM UMAX presented in Supplement I of this FSAR. The lowest service temperature for handling operations in of the 24PT1-DSC canister in reference [I.1.2.1] (as indicated in Table I.8.0.1) is no greater than the lowest service temperature for handling operations of the modified HI-STORM UMAX system with HI-TRAC VW, CHA-90, and the 24PT1-DSC canister.

I.8.4.4 Creep Properties of Materials

The discussion in Subsection 8.4.4 of this FSAR is applicable to the modified HI-STORM UMAX presented in Supplement I of this FSAR. The structural components of the 24PT1-DSC canister (minimum 40 year storage service life in reference [I.1.2.1] as indicated in Table I.8.0.1) been qualified for both long-term storage and transportation conditions and therefore merit no further material evaluation in this FSAR. Brittle fracture testing of CHA-90 components made from ferritic material is specified in Supplement I.10.

HOLTEC INTERNATIONAL COPYRIGHTED MATERIAL	
HI-2115090	Proposed Rev. 3.E
I.8-11	

I.8.5 WELDING MATERIAL AND WELDING SPECIFICATION

The discussion in Section 8.5 of this FSAR is applicable to the modified HI-STORM UMAX VVM presented in Supplement I of this FSAR, unless otherwise stated Supplements I.3 or I.10, or in the drawing package in Section I.5 of this FSAR.

Welding material and welding specification for the 24PT1-DSC canister are provided in reference [I.1.2.1] as indicated in Table I.8.0.1.

Welding material and welding specification for CHA-90 are provided in the drawing package in Section I.1.5 and Supplement I.10.

HOLTEC INTERNATIONAL COPYRIGHTED MATERIAL	
HI-2115090	Proposed Rev. 3.E
I.8-12	

I.8.6 BOLTS AND FASTENERS

The discussion in Section 8.6 of this FSAR is applicable to the modified HI-STORM UMAX VVM presented in Supplement I of this FSAR, unless otherwise stated in the drawing package in Section I.5 of this FSAR. Additional discussion is provided in Supplement I.3 and I.9 of this FSAR for the CHA-90 and Section 8.6 of HI-STORM FW FSAR [I.1.2.3] for the HI-TRAC VW.

The 24PT1-DSC canister is an all-welded pressure vessel with no containment boundary bolts or fasteners and no other important to safety bolts or fasteners.

HOLTEC INTERNATIONAL COPYRIGHTED MATERIAL	
HI-2115090	Proposed Rev. 3.E
I.8-13	

I.8.7 COATINGS AND CORROSION MITIGATION

The discussion in Section 8.7 of this FSAR is applicable to the modified HI-STORM UMAX VVM presented in Supplement I of this FSAR. The information provided Section 8.7 of HI-STORM FW FSAR [I.1.2.3] for the HI-TRAC VW is applicable to CHA-90. Coating(s) for the CHA-90 are specified in the drawing package in Section I.1.5 of this FSAR.

HOLTEC INTERNATIONAL COPYRIGHTED MATERIAL	
HI-2115090	Proposed Rev. 3.E
I.8-14	

I.8.8 GAMMA AND NEUTRON SHIELDING MATERIALS

The discussion in Section 8.8 of this FSAR is applicable to the modified HI-STORM UMAX VVM presented in Supplement I of this FSAR. CHA-90 Top Support Ring, Bottom Support Ring and Bottom Ring provide gamma shielding by blocking the annulus between the outside diameter of the 24PT1-DSC canister and the inner diameter of the HI-TRAC VW overpack. Similarly, the TSRA Top Shield Ring provides gamma by blocking the annulus between the outside diameter of the 24PT1-DSC canister and the inner diameter of the VVM Divider Shell. Section 5.3 of this FSAR provides a discussion on steel as a shielding material.

HOLTEC INTERNATIONAL COPYRIGHTED MATERIAL	
HI-2115090	Proposed Rev. 3.E
I.8-15	

I.8.9 NEUTRON ABSORBING MATERIALS

See Subsection I.8.2.2 of this FSAR for a discussion of Boral™ used as the neutron absorbing material in the 24PT1-DSC canister.

I.8.9.1 Qualification and Properties of Boral

Qualification and properties of Boral™ are provided in reference [I.1.2.1] as indicated in Table I.8.0.1.

I.8.9.2 Consideration of Boron Depletion

The depletion of boron in Boral™ is evaluated in reference [I.1.2.1] (as indicated in Table I.8.0.1) and the evaluation shows that boron depletion is negligible.

HOLTEC INTERNATIONAL COPYRIGHTED MATERIAL	
HI-2115090	Proposed Rev. 3.E
I.8-16	

I.8.10 SEALS

The discussion in Section 8.10 of this FSAR is applicable to the modified HI-STORM UMAX VVM presented in Supplement I of this FSAR. The HI-STORM UMAX System does not rely upon mechanical seals for maintaining the integrity of the Confinement Boundary.

HOLTEC INTERNATIONAL COPYRIGHTED MATERIAL	
HI-2115090	Proposed Rev. 3.E
I.8-17	

I.8.11 CHEMICAL AND GALVANIC REACTIONS

The discussion in Section 8.11 of this FSAR is applicable to the modified HI-STORM UMAX VVM presented in Supplement I of this FSAR. The information provided Section 8.12 of HI-STORM FW FSAR [I.1.2.3] for the HI-TRAC VW is applicable to CHA-90. As discussed in Subsection I.8.1.1, an evaluation of chemical and galvanic reactions is provided in Section 3.4 of reference [I.1.2.1] as indicated in Table I.8.0.1.

I.8.11.1 Operating Environments

The operating environments discussed in Section 8.11 of this FSAR and in Subsection 8.12.1 of the HI-STORM FW FSAR are applicable to the HI-STORM UMAX VVM presented in Supplement I.1 of this FSAR.

I.8.11.2 Compatibility of 24PT1-DSC Canister, CHA-90 and HI-TRAC VW

The component interfaces listed in Section I.8.1 are assessed for material compatibility such as chemical and galvanic reactions. The CHA-90 is in direct contact with the 24PT1-DSC and the HI-TRAC VW. CHA-90 components in contact with the 24PT1-DSC must be either stainless steel or coated with the Thermaline 450 or equivalent (same or equivalent coating as the HI-TRAC VW). CHA-90 is equipped with sliding rails made from stainless steel on which the 24PT1-DSC canister slides on when transferred into the horizontally oriented HI-TRAC VW. Thus the component interfaces between CHA-90 and the 24PT1-DSC canister and between the CHA-90 and the HI-TRAC VW are compatible for the short-term operations.

I.8.11.3 Compatibility of HI-STORM UMAX VVM and CHA-90

Contact between CHA-90 surfaces and the HI-STORM UMAX are minimal. When the CHA-90 is lowered into the VVM, the lowering of the CHA-90 stops once the bottom surface of the Bottom Ring contacts the VVM Pedestal Legs. Thus the coated carbon steel/alloy steel surfaces of the CHA-90 and the VVM are compatible for the short-term operations.

I.8.11.4 Potential Combustible Gas Generation

The loaded sealed 24PT1-DSC canister and the operations to transfer the canister to the HI-TRAC and in-turn the VVM do not introduce potential mechanisms for combustible gas generation.

I.8.11.6 Conclusion

The above evaluation leads to the conclusion that the materials selected for the modified HI-STORM UMAX System components and 24PT1-DSC are compatible with the environment for all operating conditions. There is no potential for significant corrosion, chemical reaction or galvanic reaction to shorten the intended service life of the equipment. In other words, the acceptance criteria set forth in ISG-15 are completely satisfied.

HOLTEC INTERNATIONAL COPYRIGHTED MATERIAL	
HI-2115090	Proposed Rev. 3.E
I.8-18	

I.8.12 FUEL CLADDING INTEGRITY

The discussions in Section 8.12 and Supplement I.3 of this FSAR are applicable to the modified HI-STORM UMAX VVM presented in Supplement I of this FSAR, except that the discussion on the fuel cladding integrity during short-term operations of the allowable spent fuel assembly contents of the 24PT1-DSC is provided in reference [I.1.2.1] as indicated in Table I.8.0.1.

HOLTEC INTERNATIONAL COPYRIGHTED MATERIAL	
HI-2115090	Proposed Rev. 3.E
I.8-19	

I.8.13 EXAMINATION AND TESTING

The discussion in Section 8.13 of this FSAR is applicable to the modified HI-STORM UMAX VVM presented in Supplement I of this FSAR. Examination and testing of the CHA-90 and the TSRA is discussed in Supplement I.9 of this FSAR as applicable.

I.8.13.1 Helium Leak Testing of Canister & Welds

Helium leak testing of the 24PT1-DSC canister is specified in reference [I.1.2.1] as indicated in Table I.8.0.1.

I.8.13.2 Periodic Inspections

Post-fabrication inspections are discussed in Section 10.2 of this FSAR as part of the modified HI-STORM UMAX System maintenance program. Inspections are conducted prior to fuel loading or prior to each fuel handling campaign or in the case of 24PT1-DSC, prior to loaded canister handing. Other periodic inspections are conducted during storage.

The modified HI-STORM UMAX VVM is a passive device with no moving parts. VVM vent screens are inspected monthly for damage, holes, etc. VVM external surface including identification markings is visually examined annually. The temperature monitoring system, if used, is inspected per licensee's QA program and manufacturer's recommendations.

HI-TRAC VW transfer cask inspections are performed annually for compliance with the licensing drawings. Inspections of CHA-90 are specified in Supplement I.10.

HOLTEC INTERNATIONAL COPYRIGHTED MATERIAL	
HI-2115090	Proposed Rev. 3.E
I.8-20	

I.8.14 REGULATORY COMPLIANCE

The preceding sections describe the materials used in important-to-safety SSCs and the suitability of those materials for their intended functions in the HI-STORM UMAX System presented in Supplement I.1 of this FSAR.

The requirements of 10CFR72.122(a) are met: The material properties of SSCs important to safety conform to quality standards commensurate with their safety functions.

The requirements of 10CFR72.104(a), 106(b), 124, and 128(a)(2) are met: Materials used for shielding are adequately designed and specified to perform their intended function.

The requirements of 10CFR72.122(h)(1) and 236(h) are met: The design of the DCSS and the selection of materials adequately protect the spent fuel cladding against degradation that might otherwise lead to gross rupture of the cladding by ensuring that the cladding temperature remains below the ISG-11 Rev 3 limits.

The requirements of 10CFR72.236(h) and 236(m) are met: The material properties of SSCs important-to-safety will be maintained during normal, off-normal, and accident conditions of operation as well as short-term operations so the spent fuel can be readily retrieved without posing operational safety problems.

The requirements of 10CFR72.236(g) are met: The material properties of SSCs important-to-safety will be maintained during all conditions of operation so the spent fuel can be safely stored for the specified service life and maintenance can be conducted as required.

The requirements of 10CFR72.236(h) are met: The HI-STORM UMAX System employs materials that are not vulnerable to degradation over time or react with one another during long-term storage.

HOLTEC INTERNATIONAL COPYRIGHTED MATERIAL	
HI-2115090	Proposed Rev. 3.E
I.8-21	

I.8.15 REFERENCES

None.

HOLTEC INTERNATIONAL COPYRIGHTED MATERIAL	
HI-2115090	Proposed Rev. 3.E
I.8-22	

SUPPLEMENT I.9: OPERATING PROCEDURES – 24PT1-DSC CANISTER

I.9.0 INTRODUCTION

This Supplement adds the operating procedures necessary for installation of the 24PT1-DSC into the HI-STORM UMAX system. The Supplement's scope of certification is limited to installing 24PT1-DSC canisters loaded under the NUHOMS CoC (NRC Docket 72-1029) following the design criteria described in the NUHOMS FSAR. Table I.9.0.1 is included to identify information that is incorporated by reference from the NUHOMS FSAR [I.1.2-1].

The operations described herein start with retrieval of the 24PT1-DSC canister from the NUHOMS storage module and culminate with its installation into the HI-STORM UMAX VVM. Unless otherwise noted, only operations that are revised or added based on the 24PT1-DSC handling requirements are described in this Supplement. The description of the operations governed by this Supplement pertains to

- 1) Staging the VVM cavity for acceptance of the 24PT1-DSC;
- 2) Transferring the 24PT1-DSC from the NUHOMS module into the HI-TRAC transfer cask;
- 3) Installing the 24PT1-DSC into the VVM cavity;
- 4) Placing of the Closure Lid and installing other appurtenances to place the storage system in a long-term storage configuration.

The necessary information for executing the reverse set of steps to retrieve a 24PT1-DSC canister from a storage cavity and remove the canister, if required, is likewise provided.

The guidance provided in this chapter shall be used as an aid to develop the short-term operations procedure specific to a host site that elects to deploy the HI-STORM UMAX system. The procedures provided in this chapter are prescriptive to the extent that they provide the basis and general guidance for plant personnel in preparing detailed written, site-specific, loading, handling, storage, and unloading procedures. Users may add, modify the sequence of, perform in parallel, or delete steps as necessary provided that the intent of this guidance is met and the requirements of the Certificate of Compliance (CoC) are complied with in a *literal manner*. The information provided in this chapter complies with the provisions of NUREG-1536.

The information presented in this chapter along with the technical basis of the system design described in this SAR will be used to develop detailed operating procedures. In preparing the site-specific procedures, the user must consult the conditions of the CoC, equipment-specific operating instructions, and the plant's working procedures as well as the information in this chapter to ensure that the short-term operations shall be carried out with utmost safety and ALARA.

The following generic criteria shall be used to determine whether the site-specific operating procedures developed pursuant to the guidance in this chapter are acceptable for use:

HOLTEC INTERNATIONAL COPYRIGHTED MATERIAL	
HI-2115090	Proposed Rev. 3.H
9-1	

- All heavy load handling instructions are in keeping with the guidance in industry standards and Holtec-provided instructions.
- The procedures are in conformance with this FSAR and its CoC.
- The procedures are in conformance with the NUHOMS FSAR and its CoC.
- The operational steps are ALARA.
- The procedures contain provisions for documenting successful execution of all safety significant steps for archival reference.
- Procedures contain provisions for classroom and hands-on training and for a Holtec-approved personnel qualification process to ensure that all operations personnel are adequately trained.
- The procedures are sufficiently detailed and articulated to enable craft labor to execute them in *literal compliance* with their content.

ISFSI owners are required to develop or modify existing programs and procedures to account for the implementation of the HI-STORM UMAX system. Written procedures are required to be developed or modified to account for such items as handling and storage of systems, structures and components (SSCs) identified as *important-to-safety*, heavy load handling, specialized instrument calibration, special nuclear material accountability, fuel handling procedures, training, equipment, and process qualifications. Users shall implement controls to ensure that all critical set points (e.g., Lift Weights) do not exceed the design limit of the specific equipment.

Control of the operation shall be performed in accordance with the user’s Quality Assurance (QA) program to ensure critical steps are not overlooked and that the cask has been confirmed to meet all requirements of the CoC before being released for on-site storage under 10 CFR Part 72.

ALARA warnings highlighted in this chapter are included to alert users to radiological issues. Actions identified with these items are of an advisory nature and shall be implemented based on site-specific determination by the plant’s radiation protection personnel.

Section I.9.1 provides the technical basis for loading and unloading procedures. Section I.9.2 provides the guidance for loading the HI-STORM UMAX system. Section I.9.3 provides the procedures for ISFSI operations and general guidance for performing maintenance and for responding to abnormal events that may occur during normal loading operations. Section I.9.4 provides the procedure for unloading the HI-STORM UMAX System and removing spent fuel from the 24PT1-DSC cansiter. The loading steps and the illustrations are illustrative (rather than definitive) because the architecture of a particular plant and its ISFSI may require significant adaptations for a safe and ALARA loading program.

HOLTEC INTERNATIONAL COPYRIGHTED MATERIAL	
HI-2115090	Proposed Rev. 3.H
9-2	

Table I.9.0.1: Material Incorporated by Reference

Information Incorporated by Reference	Source of the Information	NRC Approval of Material Incorporated by Reference	Location in this FSAR where Material is Incorporated	Technical Justification of Applicability to HI-STORM UMAX
24-PT1-DSC Retrieval from the AHSM	Section 8.2.1 of Standardized Advanced NUHOMS FSAR [I.1.2.1]	SER Advanced NUHOMS Amendment 0, Reference [I.1.2-2]	I.9.2.3 Step 5	The operations for canister retrieval are approved under the NUHOMS CoC (NRC Docket 72-1029) following the criteria described in the NUHOMS FSAR.
HI-TRAC receipt inspection and cleanliness inspection	Table 9.2.5 of HI-STORM FW FSAR [I.1.2-3]	SER HI-STORM FW Amendment 0, Reference [I.1.2-3]	I.9.2.3 Step 3 and I.9.4.2 Step 2	The operations for HI-TRAC receipt inspection and cleanliness inspection are approved under the HI-STORM UMAX CoC (NRC 72-1040) following the criteria described in the HI-STORM FW FSAR.
<u>Removal of fuel from the 24PT1-DSC canister</u>	<u>Section 8.2.2 of Standardized Advanced NUHOMS FSAR [I.1.2.1]</u>	<u>SER Advanced NUHOMS Amendment 0, Reference [I.1.2-2]</u>	<u>I.9.4.4</u>	<u>The operations for removal of fuel from canister are approved under the NUHOMS CoC (NRC Docket 72-1029) following the criteria described in the NUHOMS FSAR.</u>

HOLTEC INTERNATIONAL COPYRIGHTED MATERIAL	
HI-2115090	Proposed Rev. 3.H
9-3	

I.9.1 TECHNICAL AND SAFETY BASIS FOR LOADING AND UNLOADING PROCEDURES

The technical and safety basis for loading and unloading the 24PT1-DSC canister in the HI-STORM UMAX System described in Section 9.1 apply to this Supplement. All references to the MPC in Section 9.1 shall be interpreted to apply to the 24PT1-DSC.

HOLTEC INTERNATIONAL COPYRIGHTED MATERIAL	
HI-2115090	Proposed Rev. 3.H
9-4	

I.9.2 PROCEDURE FOR PLACING THE LOADED 24PT1-DSC IN THE HI-STORM UMAX VVM

1.9.2.1 Overview of Loading Operations

The loading operations of HI-STORM UMAX System with the 24PT1-DSC differ from the operations described in Section 9.2.1 in that the process starts with retrieval of the canister from the NUHOMS storage module. To account for differences in the canister configuration, a canister handling apparatus (CHA) and Top Seismic Restraint Assembly (TSRA) are also required. Therefore, to address these differences, additional steps are required for transfer of the canister to the HI-TRAC and for installation of the canister into the HI-STORM UMAX VVM.

1.9.2.2 Preparation for Transfer of the 24PT1-DSC Canister

The steps and requirements for the preparation of the VVM, VCT, and the mating device in Section 9.2.2 apply to this Supplement. The required equipment list, as noted below, is appended and revised. All references to the MPC in Section 9.2.2 shall be interpreted to apply to the 24PT1-DSC.

The required equipment/devices that participate in transferring the 24PT1-DSC canister into dry storage are, as a minimum:

1. Equipment to remove and install the VVM Closure Lid;
2. The vertical cask transporter (VCT) or equivalent load handling devices with redundant drop protection features;
3. The HI-TRAC VW transfer cask, with the Cask Handling Apparatus installed;
4. The NUHOMS transfer cask;
5. The NUHOMS-to-HI-TRAC transfer cask mating collar;
6. The HI-TRAC VW tilting apparatus;
7. The UMAX VVM Mating Device;
8. HI-TRAC and CHA lifting and handling devices;
9. The Top Seismic Restraint Assembly (TSRA).

HOLTEC INTERNATIONAL COPYRIGHTED MATERIAL	
HI-2115090	Proposed Rev. 3.H
9-5	

I.9.2.3 Transfer of the 24PT1-DSC Canister into Storage

The operational steps presented in the following are intended to provide guidance to the user in preparing site-specific loading procedures that must be prepared with due consideration of the particular site's physical characteristics, its rigging plan, and its safety/ALARA practices. Figure I.9.2.1 provides a pictorial overview of the loading steps. The loading steps assume that the canisters have been loaded, sealed, and dried in accordance with CoC 72-1029, which is a condition of the HI-STORM UMAX license for the 24PT1-DSC canister.

Transfer Steps

1. Remove the UMAX Closure Lid using a crane or other equivalent lifting device (refer to Figure 9.2.3).
2. Install the Mating Device on the UMAX VVM.
3. Perform a HI-TRAC receipt inspection and cleanliness inspection in accordance with a written inspection checklist in accordance with the HI-STORM FW System FSAR (See Table I.9.0.1). Transport the HI-TRAC to the ISFSI using the cask transporter or other suitable device.
4. Install the HI-TRAC transfer cask (with CHA installed) on the tilting frame and down-end in preparation for receiving the 24PT1-DSC canister.
5. Retrieve the 24PT1-DSC canister from the AHSM into the NUHOMS transfer cask per Section 8.2.1 of the Standardized Advanced NUHOMS FSAR [\[I.1.2.1\]](#).
6. Position and align the NUHOMS transfer cask with the HI-TRAC transfer cask (with CHA installed), using the transfer cask mating collar.
7. Engage and extend the NUHOMS transfer cask hydraulic ram, to transfer the 24PT1-DSC into the HI-TRAC transfer cask.
8. Disengage the NUHOMS transfer cask and mating collar from the HI-TRAC.

ALARA Warning:

Temporary shielding may be used to reduce personnel dose during transfer operations. If ALARA considerations dictate that temporary shielding not be used, personnel must remain clear of the immediate area around the HI-TRAC following disengagement of the NUHOMS transfer cask.

9. At the user's discretion, install temporary shielding to cover the potential streaming paths from the top of the HI-TRAC.
10. Up-end the HI-TRAC and disengage the HI-TRAC from the tilting frame.
11. Perform a transport route walkdown to ensure that the transport conditions are met.
12. Transport the HI-TRAC to the VVM (prepared per Section I.9.2.2) using the vertical cask crawler (VCT) or other suitable transportation device.

HOLTEC INTERNATIONAL COPYRIGHTED MATERIAL	
HI-2115090	Proposed Rev. 3.H
9-6	

13. Place the loaded HI-TRAC transfer cask on the Mating Device.
14. Rig the CHA to the lift attachments of the VCT or other suitable downloading device.
Raise the CHA slightly to remove its weight from the HI-TRAC bottom lid (also called the Pool lid).
15. Unbolt the bottom lid from the HI-TRAC body and lower the lid into the Mating Device.
16. Open the Mating Device drawer.

ALARA Warning:

Temporary shielding may be used to reduce personnel dose during transfer operations. If ALARA considerations dictate that temporary shielding not be used, personnel must remain clear of the immediate area around the Mating Device drawer during canister downloading.

17. At the user's discretion, install temporary shielding to cover the potential streaming paths around the Mating Device drawer.
18. Lower the CHA (with 24PT1-DSC) into the VVM.
19. Verify that the CHA (with canister) is fully seated in the VVM and the CHA rigging is slack.

Caution:

Operations steps that occur with the 24PT1-DSC in the VVM with the Mating Device installed and the drawer closed must be performed in an expeditious manner to avoid excessive heating of the canister and fuel. The Mating Device drawer shall remain open, to the extent possible, such that the open air path is at least as large as 50% of the VVM vent flow area until the Mating Device is to be removed from the VVM. The Mating Device must be removed or the drawer opened to establish air cooling within the time limits of the 100% blocked duct accident condition. Alternatively the Mating Device may be equipped with vent passages. In the event of equipment malfunction that results in the blockage of air flow, corrective actions must occur within the time limits of the 100% blocked duct accident condition.

20. Disengage the CHA lifting blocks from the canister.
21. Lift the CHA (without canister) from the VVM into the HI-TRAC.
22. Remove any temporary shielding and close the Mating Device drawer.
23. Reinstall the HI-TRAC Bottom lid.

ALARA Warning:

Personnel should remain clear (to the maximum extent practicable) of the VVM annulus when HI-TRAC is being removed to comply with ALARA requirements.

HOLTEC INTERNATIONAL COPYRIGHTED MATERIAL

HI-2115090

Proposed Rev. 3.H

24. Remove the HI-TRAC transfer cask (with the CHA inside) from the top of the Mating Device.
25. Fully open the Mating Device drawer.

ALARA Warning:

Personnel should remain clear (to the maximum extent practicable) of the VVM annulus during and after TSRA placement to comply with ALARA requirements.

26. Using the VCT, crane or other equivalent lifting device, lower the TSRA into the VVM until it seats on the DSA tapered blocks.
27. Verify TSRA is appropriately positioned (engaged with both the outer diameter of the 24PT1-DSC and the DSA tapered blocks) and remove rigging from TSRA.
28. Close the Mating Device drawer and remove the Mating Device from the top of the VVM.

Guidance:

The VVM lid shall be preferably kept less than 2 feet above the top surface of the VVM while over the 24PT1-DSC. This lift limit action is purely a defense-in-depth measure because the Closure Lid cannot fall and impact the canister because of geometric constraints.

29. Install the VVM lid. Check that the rigging (in its specific configuration) is rated to lift the load (rated to lift two times the load per NUREG 0612).
30. Remove the VVM lid rigging equipment and re-install the VVM lid outlet vent cover (if previously removed).
31. Install the VVM temperature monitoring elements (if used).
32. Install the flue extensions of adjacent VVMs, if removed to avoid interference with loading operations.
33. Perform shielding effectiveness testing, if required by the Technical Specification.

HOLTEC INTERNATIONAL COPYRIGHTED MATERIAL	
HI-2115090	Proposed Rev. 3.H
9-8	

**FIGURE I.9.2.1: PICTORIAL OVERVIEW OF THE LOADING STEPS
(SHEET 1 OF 6)**

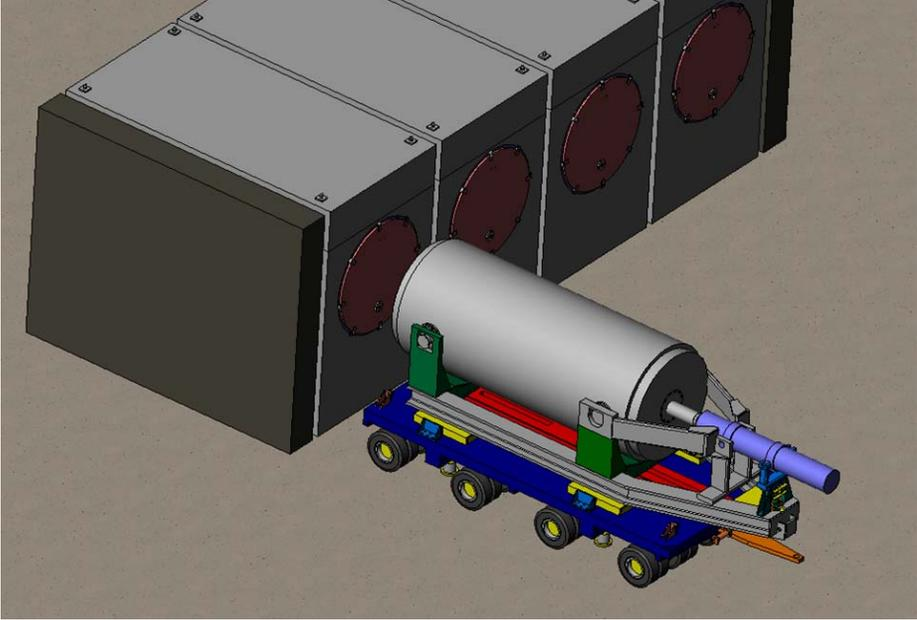
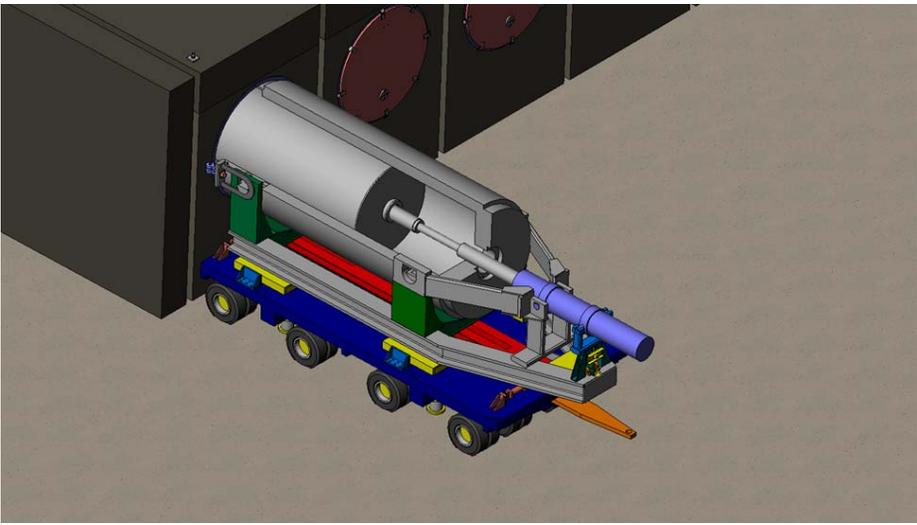
<p>A. Transfer cask on trailer is aligned with NUHOMS module where canister is stored.</p>	
<p>B. Canister is transferred into NUHOMS transfer cask.</p>	

Note: The design features of the HI-STORM UMAX System are the exclusive intellectual property of Holtec International under U.S. and international patent right laws. Minor details of the HI-STORM UMAX depicted here and other figures in this FSAR may vary slightly from the licensing drawings in Section 1.5.

<p>HOLTEC INTERNATIONAL COPYRIGHTED MATERIAL</p>	
<p>HI-2115090</p>	<p>Proposed Rev. 3.H</p>
<p>9-9</p>	

**FIGURE I.9.2.1: PICTORIAL OVERVIEW OF THE LOADING STEPS
(SHEET 2 OF 6)**

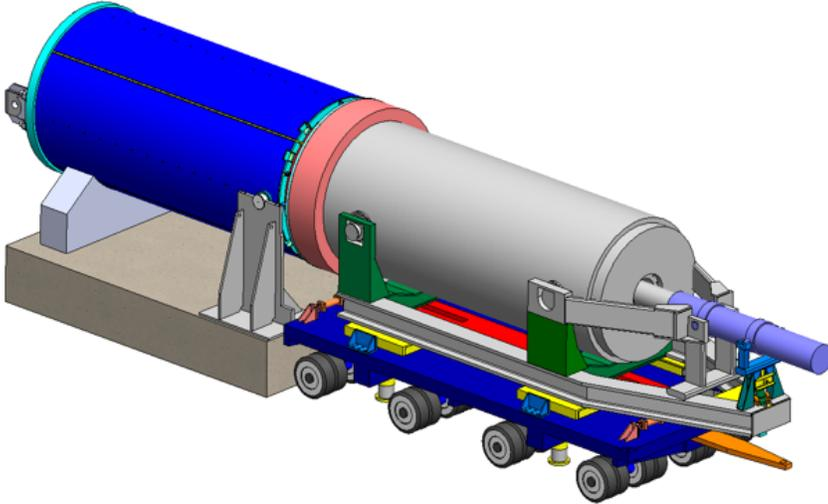
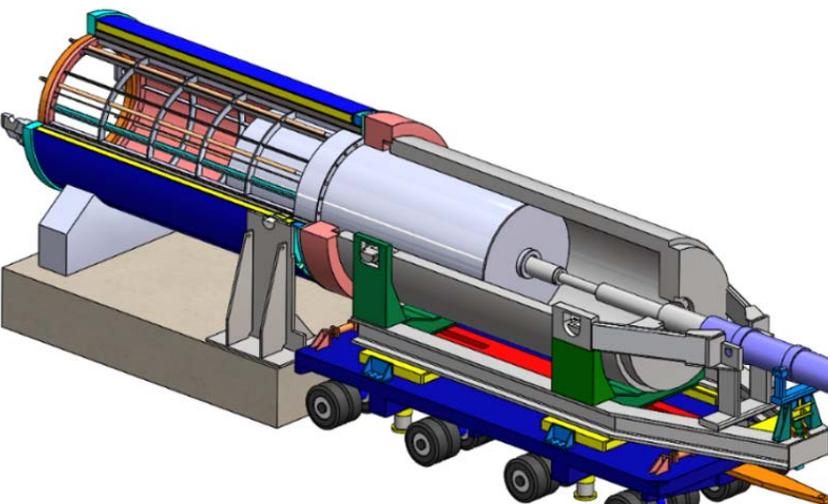
<p>C. NUHOMS transfer cask is aligned with HI-STORM FW HI-TRAC (installed on tilting fixture) using docking collar</p>	
<p>D. Canister is transferred into HI-TRAC (with CHA installed) using NUHOMS transfer cask hydraulic ram</p>	

Note: The design features of the HI-STORM UMAX System are the exclusive intellectual property of Holtec International under U.S. and international patent right laws. Minor details of the HI-STORM UMAX depicted here and other figures in this FSAR may vary slightly from the licensing drawings in Section 1.5.

<p>HOLTEC INTERNATIONAL COPYRIGHTED MATERIAL</p>	
<p>HI-2115090</p>	<p>Proposed Rev. 3.H</p>
<p>9-10</p>	

**FIGURE I.9.2.1: PICTORIAL OVERVIEW OF THE LOADING STEPS
(SHEET 3 OF 6)**

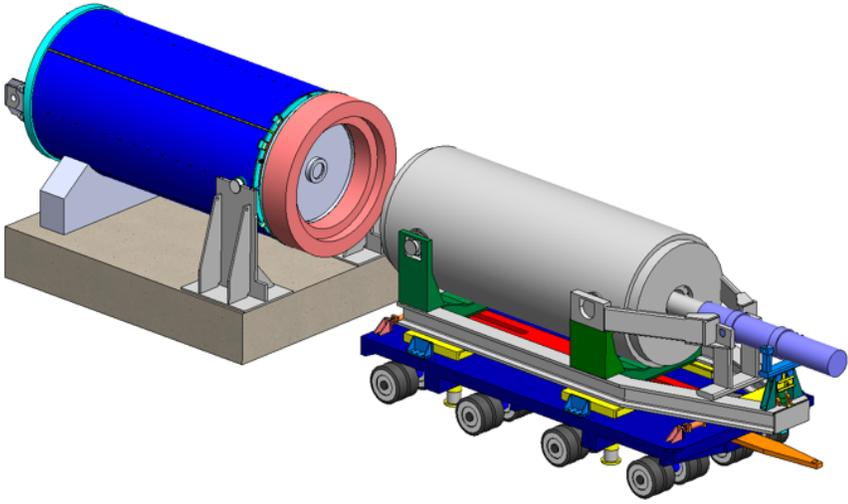
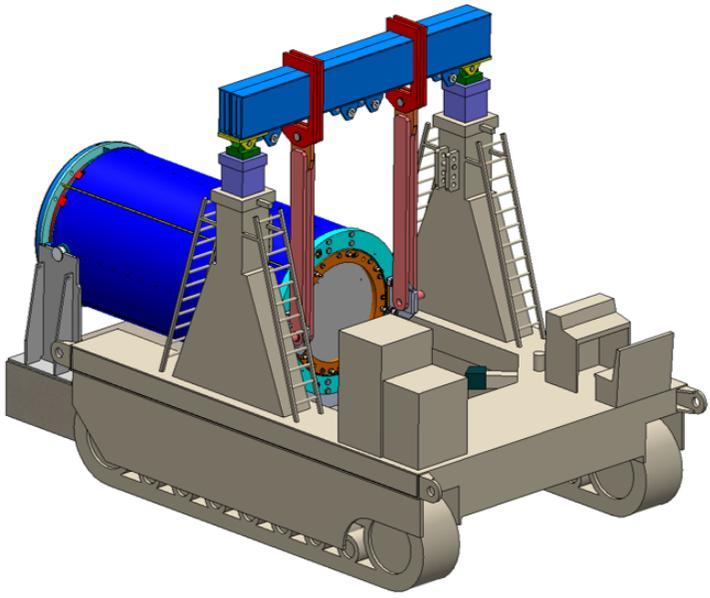
<p>E. NUMOMS transfer cask is disengaged from HI-TRAC</p>	
<p>F. HI-TRAC is rigged for up-ending using the VCT</p>	

Note: The design features of the HI-STORM UMAX System are the exclusive intellectual property of Holtec International under U.S. and international patent right laws. Minor details of the HI-STORM UMAX depicted here and other figures in this FSAR may vary slightly from the licensing drawings in Section 1.5.

<p>HOLTEC INTERNATIONAL COPYRIGHTED MATERIAL</p>	
<p>HI-2115090</p>	<p>Proposed Rev. 3.H</p>
<p>9-11</p>	

**FIGURE I.9.2.1: PICTORIAL OVERVIEW OF THE LOADING STEPS
(SHEET 4 OF 6)**

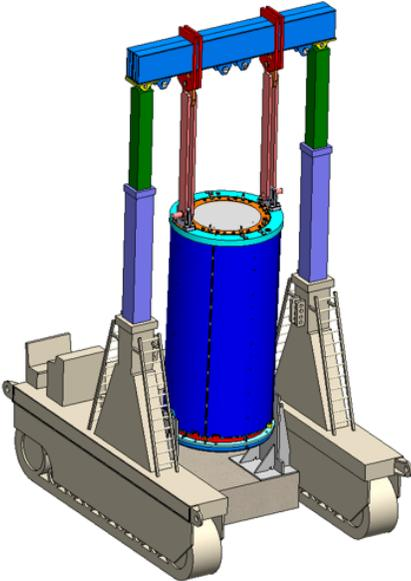
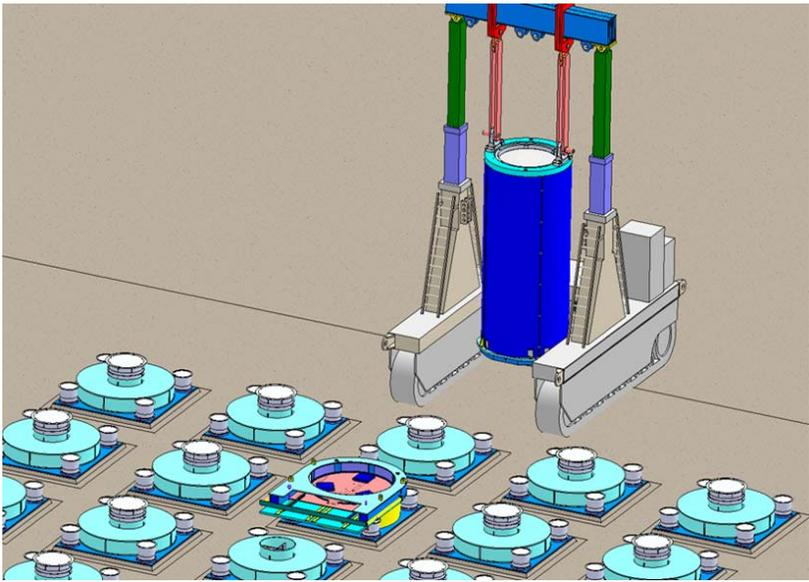
<p>G. HI-TRAC is up-ended and disconnected from the tilting fixture</p>	
<p>H. HI-TRAC is transported to the ISFSI pad</p>	

Note: The design features of the HI-STORM UMAX System are the exclusive intellectual property of Holtec International under U.S. and international patent right laws. Minor details of the HI-STORM UMAX depicted here and other figures in this FSAR may vary slightly from the licensing drawings in Section 1.5.

<p>HOLTEC INTERNATIONAL COPYRIGHTED MATERIAL</p>	
<p>HI-2115090</p>	<p>Proposed Rev. 3.H</p>
<p>9-12</p>	

**FIGURE I.9.2.1: PICTORIAL OVERVIEW OF THE LOADING STEPS
(SHEET 5 OF 6)**

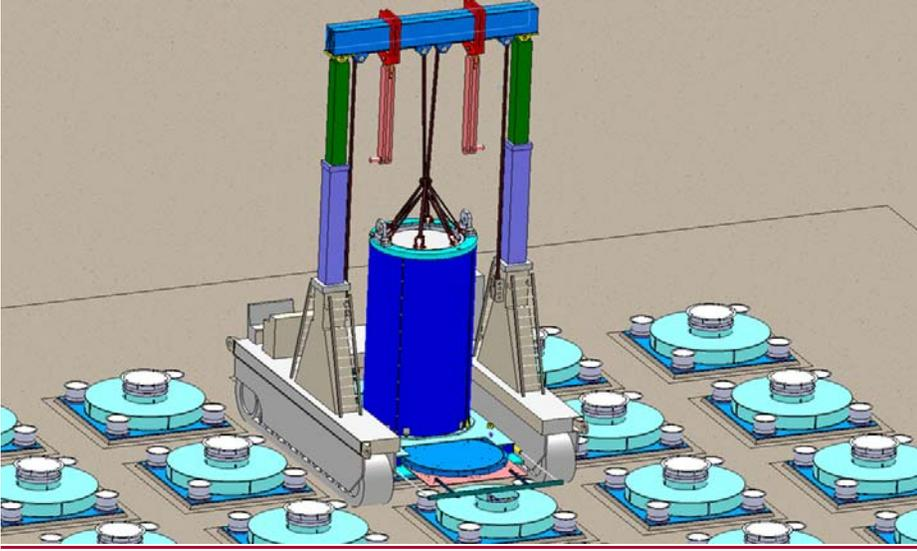
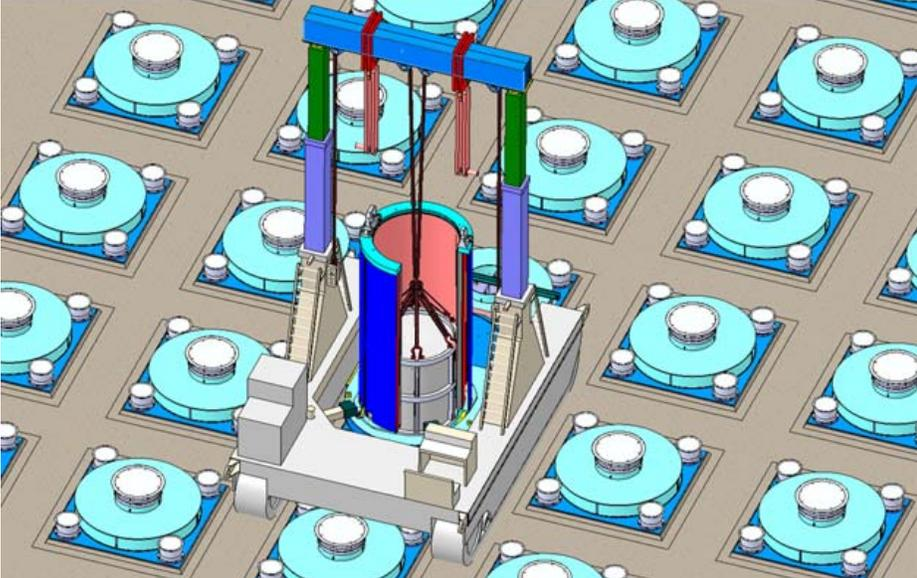
<p>I. HI-TRAC is mated to the UMAX VVM and the CHA is rigged for lowering</p>	
<p>J. Canister is lowered into UMAX VVM</p>	

Note: The design features of the HI-STORM UMAX System are the exclusive intellectual property of Holtec International under U.S. and international patent right laws. Minor details of the HI-STORM UMAX depicted here and other figures in this FSAR may vary slightly from the licensing drawings in Section 1.5.

<p>HOLTEC INTERNATIONAL COPYRIGHTED MATERIAL</p>	
<p>HI-2115090</p>	<p>Proposed Rev. 3.H</p>
<p>9-13</p>	

**FIGURE I.9.2.1: PICTORIAL OVERVIEW OF THE LOADING STEPS
(SHEET 6 OF 6)**

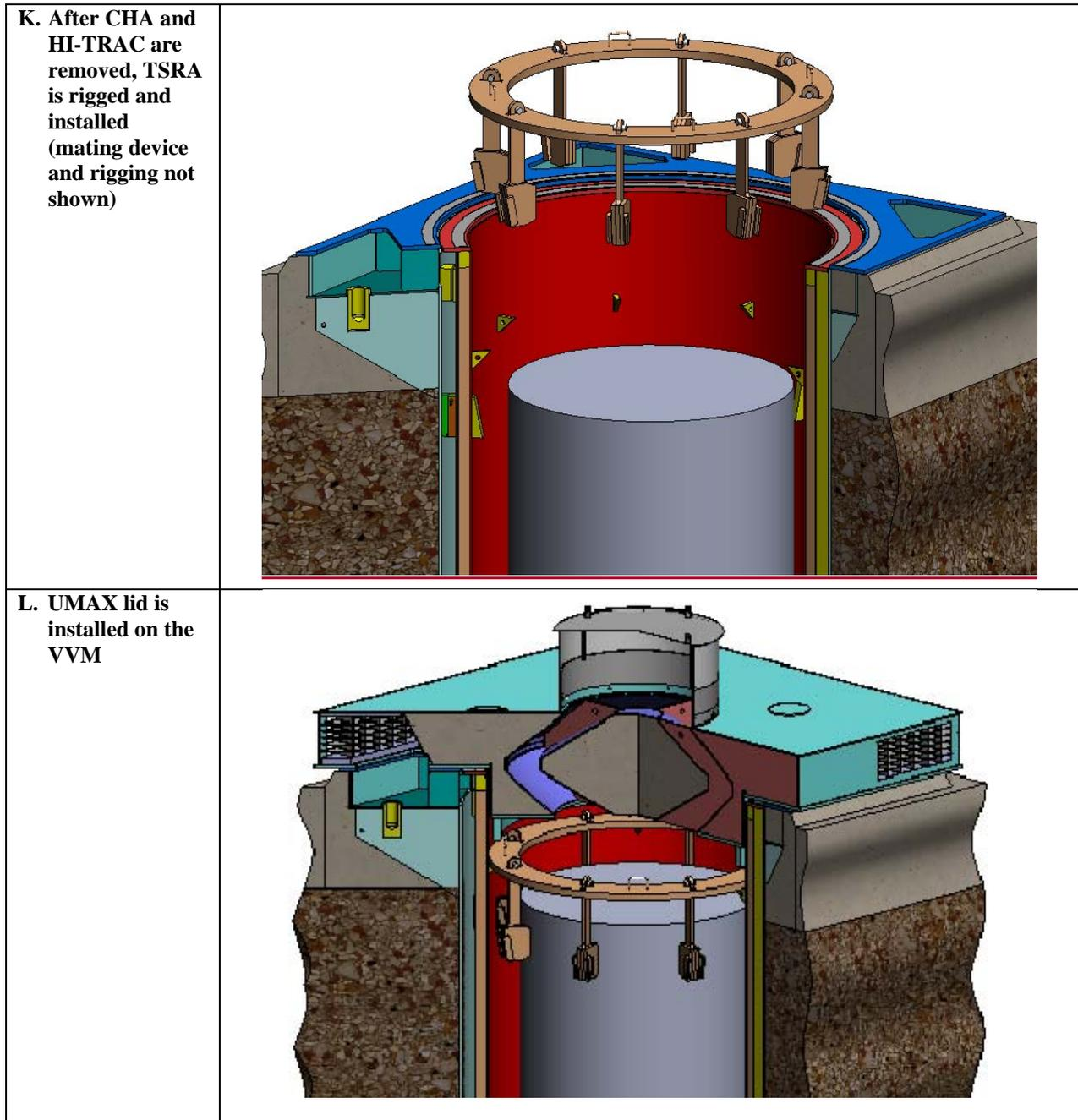

Note: The design features of the HI-STORM UMAX System are the exclusive intellectual property of Holtec International under U.S. and international patent right laws. Minor details of the HI-STORM UMAX depicted here and other figures in this FSAR may vary slightly from the licensing drawings in Section 1.5.

HOLTEC INTERNATIONAL COPYRIGHTED MATERIAL	
HI-2115090	Proposed Rev. 3.H
9-14	

I.9.3 ACTIVITIES PERTAINING TO ISFSI OPERATIONS

The activities pertaining to ISFSI operations described in Section 9.3 apply to this Supplement, with the following exception:

Section I.9.4 may be used as guidance for unloading the canister from the HI-STORM UMAX.

HOLTEC INTERNATIONAL COPYRIGHTED MATERIAL	
HI-2115090	Proposed Rev. 3.H
9-15	

I.9.4 PROCEDURE FOR REMOVING AND UNLOADING THE 24PT1-DSC

I.9.4.1 Overview of HI-STORM UMAX System Unloading Operations

The 24PT1-DSC is recovered from the HI-STORM UMAX VVM at the ISFSI using the same set of steps as described in Section I.9.2, except that the order is basically reversed. The canister is then transferred into the NUHOMS transfer cask for further processing. Similarly, these steps also basically reverse many of the steps in Section I.9.2. The scope of the detailed steps in this Section of the Supplement ends with the 24PT1-DSC transferred into the NUHOMS transfer cask. Removal of fuel from the 24PT1-DSC, if required, is incorporated by reference from Section 8.2.2 of [I.2.1] into this FSAR.

I.9.4.2 Canister Recovery from the HI-STORM UMAX VVM

PRINCIPAL OPERATING STEPS

1. If necessary, perform a transport route walkdown to ensure that the cask transport conditions are met for transporting the loaded HI-TRAC transfer cask. Remove all physical obstructions (e.g., flue extensions) that may interfere with the movement of the VCT.
2. Perform a HI-TRAC receipt inspection and cleanliness inspection in accordance with a written inspection checklist in accordance with the HI-STORM FW System FSAR (See Table I.9.0.1). Transport the HI-TRAC to the ISFSI using the cask transporter or other suitable device.
3. Remove the VVM temperature monitoring equipment (if used) from the VVM cavity.

Guidance:

The VVM lid shall be preferably kept less than 2 feet above the top surface of the VVM while over the 24PT1-DSC. This lift limit action is purely a defense-in-depth measure because the Closure Lid cannot fall and impact the canister because of geometric constraints.

4. Remove the VVM Closure lid from the VVM cavity, preferably keeping its height above the top of the CEC Flange to under 2 feet.

Caution:

Operations steps that occur with the canister in the VVM with the Mating Device installed and the drawer closed must be performed in an expeditious manner to avoid excessive heating of the canister and fuel. The Mating Device must be removed or the drawer opened to establish air cooling within the time limits described in Section I.4.5. In the event of equipment malfunction that results in the blockage of air flow, corrective actions must occur within the time limits of the 100% blocked duct accident condition.

HOLTEC INTERNATIONAL COPYRIGHTED MATERIAL

HI-2115090

Proposed Rev. 3.H

9-16

5. Install the Mating Device on the VVM.
6. Open the Mating Device drawer and remove the TRSA from the VVM.
7. If previously drained, fill the neutron shield jacket of the HI-TRAC with plant demineralized water or an approved antifreeze solution as necessary. Ensure that the fill and drain plugs are installed.
8. If not already installed, insert the CHA in the HI-TRAC and rig the HI-TRAC to the VCT or other lifting device.
9. Align the HI-TRAC over the Mating Device and VVM and mate the casks.
10. Rig the CHA to the lift attachments of the VCT or other suitable downloading device. Raise the CHA slightly to remove its weight from the HI-TRAC bottom lid (also called the Pool lid).
11. Unbolt the bottom lid from the HI-TRAC and lower into the Mating Device drawer.
12. Open the Mating Device drawer.

ALARA Warning:

Temporary shielding may be used to reduce personnel dose during transfer operations. If ALARA considerations dictate that temporary shielding not be used, personnel must remain clear of the immediate area around the Mating Device drawer during canister downloading.

13. At the user's discretion, install temporary shielding to cover the gap above and below the Mating Device drawer.
14. Lower the CHA through the Mating Device until it seats at the base of the VVM.
15. Engage the CHA lifting blocks with the 24PT1-DSC.
16. Raise the CHA with the 24PT1-DSC into HI-TRAC.
17. Verify the CHA is in the full-up position.
18. Close the Mating Device drawer.
19. Reinstall the bottom lid to the HI-TRAC.
20. Lower the CHA (with 24PT1-DSC canister) onto the bottom lid.
21. Remove the HI-TRAC (with 24PT1-DSC canister) from the top of the VVM.
22. Transport the HI-TRAC (with 24PT1-DSC canister) to the designated location using the cask transporter or other suitable device.
23. Remove the Mating Device from the VVM.
24. Install the VVM lid and vent flue assemblies on all storage cavities, where they were removed, to prevent entry of foreign objects into the VVM.

HOLTEC INTERNATIONAL COPYRIGHTED MATERIAL	
HI-2115090	Proposed Rev. 3.H
9-17	

I.9.4.3 Canister Transfer into NUHOMS Transfer Cask

1. Install the HI-TRAC transfer cask (loaded with 24PT1-DSC) on the tilting frame and down-end in preparation for unloading the 24PT1-DSC canister.

ALARA Warning:

Temporary shielding may be used to reduce personnel dose during transfer operations. If ALARA considerations dictate that temporary shielding not be used, personnel must remain clear of the immediate area around the HI-TRAC prior to engagement of the NUHOMS transfer cask.

2. Ready the NUHOMS transfer caske, transfer trailer, and support skid for service and tow the trailer to the transfer area.
3. Remove the NUHOMS transfer cask top cover plate. Back the trailer to within a few inches of the HI-TRAC.
4. Position and align the NUHOMS transfer cask with the HI-TRAC transfer cask using the transfer cask mating collar.
5. Install and align the the hydraulic ram with the NUHOMS transfer cask.
6. Extend the ram through the NUHOMS transfer cask into the HI-TRAC until it is inserted in the 24PT1-DSC grapple ring.
7. Activate the arms on the ram grapple mechanism to engage the grapple ring.
8. Retract the NUHOMS transfer cask hydraulic ram, to transfer the 24PT1-DSC into the 24PT1-DSC transfer cask.
9. Retract the hydraulic ram grapple arms and disengage the ram from the transfer cask.
10. Replace the cask ram access cover plate and remove the transfer cask restraints.
11. Disengage the NUHOMS transfer cask and mating collar from the HI-TRAC.
12. Install the NUHOMS transfer cask top cover plate and ready the trailer for transport.
13. Perform a transport route walkdown to ensure that the transport conditions are met.

I.9.4.4 Removal of Fuel from the 24PT1-DSC

Steps for removal of fuel from the 24PT1-DSC canister are incorporated by reference from Section 8.2.2 of the Standardized Advanced NUHOMS FSAR [I.1.2-1].

HOLTEC INTERNATIONAL COPYRIGHTED MATERIAL	
HI-2115090	Proposed Rev. 3.H
9-18	

I.9.5 REGULATORY COMPLIANCE:

The operational steps required to transfer a 24PT1-DSC from AHSM storage to storage in a HI-STORM UMAX VVM cavity have been described in this chapter. These steps are, of necessity, generic in their description and may require adaptation to a specific ISFSI. The implementation steps are nevertheless sufficiently detailed to lead to the conclusion that the guidelines of safety and ALARA set down in NUREG-1536 are fully satisfied. In particular, it can be concluded that:

- i. There are no radiation streaming paths from the caniser during its transfer operation.
- ii. The Mating Device handling operations occur near grade level thus eliminating the need for ladders/platforms and improving the human factors aspects.
- iii. There are no freestanding structures in the canister transfer operations and thus there is no risk of uncontrolled load movement under a (hypothetical) extreme environmental event such as tornado or high winds.
- iv. The ventilation paths to passively cool the canister using ambient air during the transfer operation is maintained at all times (except during brief operations as mentioned above) thus protecting the fuel cladding from overheating and eliminating any thermally guided time limit on the duration for implementing the transfer steps.
- v. All heavy load handling is carried out by handling devices that are equipped with redundant load drop protection features.
- vi. Each storage cavity is independently accessible. Installation or removal of any canister does not have to contend with other stored canisters.
- vii. Because the 24PT1-DSC insertion into (and withdrawal from) the UMAX VVM occurs in the vertical configuration with ample lateral clearances, there is no risk of scratching or gouging of the canister's external surface (Confinement Boundary) during these operations. Thus the ASME Section III Class 1 prohibition against damage to the pressure retaining boundary is maintained. Justification for operations involving retrieval of the 24PT1-DSC canister from the NUHOMS storage module in the horizontal position are provided in the NUHOMS FSAR [I.1.2-1].

It is thus concluded that operations for storage of the 24-PT1-DSC in the HI-STORM UMAX ISFSI are engineered to meet the safety and ALARA imperatives contemplated in 10CFR 72 in full measures.

HOLTEC INTERNATIONAL COPYRIGHTED MATERIAL	
HI-2115090	Proposed Rev. 3.H
9-19	

I.9.6 REFERENCES:

There are no additional References in this Supplement.

HOLTEC INTERNATIONAL COPYRIGHTED MATERIAL	
HI-2115090	Proposed Rev. 3.H
9-20	

SUPPLEMENT I.10 ACCEPTANCE CRITERIA AND MAINTENANCE PROGRAM FOR 24PT1-DSC SYSTEMS

I.10.0. GENERAL INFORMATION

Supplement I adds the 24PT1-DSC canister to the HI-STORM UMAX system [I.1.2-1]. Only those design features of “UMAX” that are revised or added to incorporate the 24PT1-DSC canister are described in this supplement. This supplement also references to the main body of the FSAR where existing safety analyses are bounding, as applicable. The material in this supplement is organized to mirror the corresponding material in the main body of the FSAR with the letter I. inserted before each chapter/section/subsection/paragraph number. Thus the numeric sequence I.m.n.p.r indicates that the material belongs to Supplement I, Chapter #m, Section #n , sub-section# p and paragraph # r. (m, n, p and r are numeric values). Thus, the numbering of the material in the supplement is readily distinguished from the main FSAR’s while the content correspondence is maintained.

This supplement addresses the fabrication, inspection, test, and maintenance programs for the 24PT1-DSC canister, the HI-STORM UMAX, and the Canister Handling Apparatus-90 (CHA-90). In particular this supplement addresses the fabrication, inspections, test, and maintenance programs to be conducted on the 24PT1-DSC canister, the HI-STORM UMAX, and HI-STORM UMAX supplemental features for the 24PT1-DSC such as the Seismic Restraint Ring or Divider Shell Appurtenance Assembly, and the CHA-90. These programs verify that the structures, systems, and components (SSC’s) classified as important-to-safety have been fabricated, assembled, inspected, tested, accepted, and maintained in accordance with the requirements set forth in this FSAR, the applicable regulatory requirements, and the Certificate of Compliance (CoC).

HOLTEC INTERNATIONAL COPYRIGHTED MATERIAL	
HI-2115090	Proposed Rev. 3.E
I.10-1	

Table I.10.0.1				
MATERIAL INCORPORATED BY REFERENCE				
Information Incorporated by Reference	Source of Information	NRC Approval of Material Incorporated by Reference	Location in this FSAR where Material is Incorporated	Technical Justification of Applicability to HI-STORM UMAX
Visual Inspections and Measurement Requirements	Reference [I.10.1] Section 9.1.1	SER Advanced NUHOMS Amendment 0, Reference [I.10.5]	I.10.1.1.1	The canister is fabricated, inspected, tested, and maintained under the NUHOMS CoC (NRC Docket 72-1029) following the criteria described in the NUHOMS FSAR. Storage within the HI-STORM UMAX will not affect the Visual Inspections and Measurement Requirements since the canister shall already be fabricated and loaded prior to storage within the HI-STORM UMAX.
Weld Examination Requirements	Reference [I.10.1] Section 9.1.2	SER Advanced NUHOMS Amendment 0, Reference [I.10.5]	I.10.1.1, I.10.1.2, I.10.1.3	The canister is fabricated, inspected, tested, and maintained under the NUHOMS CoC (NRC Docket 72-1029) following the criteria described in the NUHOMS FSAR. Storage within the HI-STORM UMAX will not affect the Weld Examination Requirements since the canister shall already be fabricated and loaded prior to storage within the HI-STORM UMAX.
Leak Test Requirements	Reference [I.10.1] Section 9.1.3	SER Advanced NUHOMS Amendment 0, Reference [I.10.5]	I.10.1.4	The canister is fabricated, inspected, tested, and maintained under the NUHOMS CoC (NRC Docket 72-1029) following the criteria described in the NUHOMS FSAR. Storage within the HI-STORM UMAX will not affect the Leak Test Requirements since the canister shall already be fabricated and loaded prior to storage within the HI-STORM UMAX.

HOLTEC INTERNATIONAL COPYRIGHTED MATERIAL	
HI-2115090	Proposed Rev. 3.E
I.10-2	

Table I.10.0.1

MATERIAL INCORPORATED BY REFERENCE

Information Incorporated by Reference	Source of Information	NRC Approval of Material Incorporated by Reference	Location in this FSAR where Material is Incorporated	Technical Justification of Applicability to HI-STORM UMAX
Component Test Requirements	Reference [I.10.1] Section 9.1.4	SER Advanced NUHOMS Amendment 0, Reference [I.10.5]	I.10.1.5	The canister is fabricated, inspected, tested, and maintained under the NUHOMS CoC (NRC Docket 72-1029) following the criteria described in the NUHOMS FSAR. Storage within the HI-STORM UMAX will not affect the Component Test Requirements since the canister shall already be fabricated and loaded prior to storage within the HI-STORM UMAX.
Shielding Integrity	Reference [I.10.1] Section 9.1.5	SER Advanced NUHOMS Amendment 0, Reference [I.10.5]	I.10.1.6	The canister is fabricated, inspected, tested, and maintained under the NUHOMS CoC (NRC Docket 72-1029) following the criteria described in the NUHOMS FSAR. Storage within the HI-STORM UMAX will not affect Shielding Integrity since the canister shall already be fabricated and loaded prior to storage within the HI-STORM UMAX.
Thermal Acceptance	Reference [I.10.1] Section 9.1.6	SER Advanced NUHOMS Amendment 0, Reference [I.10.5]	I.10.1.7	The canister is fabricated, inspected, tested, and maintained under the NUHOMS CoC (NRC Docket 72-1029) following the criteria described in the NUHOMS FSAR. Storage within the HI-STORM UMAX will not affect the Thermal Acceptance criteria since the canister shall already be fabricated and loaded prior to storage within the HI-STORM UMAX.

HOLTEC INTERNATIONAL COPYRIGHTED MATERIAL

HI-2115090

Proposed Rev. 3.E

I.10-3

Table I.10.0.1				
MATERIAL INCORPORATED BY REFERENCE				
Information Incorporated by Reference	Source of Information	NRC Approval of Material Incorporated by Reference	Location in this FSAR where Material is Incorporated	Technical Justification of Applicability to HI-STORM UMAX
Inspection and Testing Requirements	Reference [I.10.1] Section 9.2	SER Advanced NUHOMS Amendment 0, Reference [I.10.5]	I.10.3	The canister is fabricated, inspected, tested, and maintained under the NUHOMS CoC (NRC Docket 72-1029) following the criteria described in the NUHOMS FSAR. Storage within the HI-STORM UMAX will not affect the Inspection and Testing Requirements since the canister shall already be fabricated and loaded prior to storage within the HI-STORM UMAX.
Maintenance Program	Reference [I.10.1] Section 9.2	SER Advanced NUHOMS Amendment 0, Reference [I.10.5]	I.10.4	The canister is fabricated, inspected, tested, and maintained under the NUHOMS CoC (NRC Docket 72-1029) following the criteria described in the NUHOMS FSAR. Storage within the HI-STORM UMAX will not affect maintenance program since no additional maintenance is required once the canister is loaded and stored per the NUHOMS FSAR. Due to the transport and age restrictions on the 24PT1-DSC no additional maintenance is required for storage in a HI-STORM UMAX.
Identification Requirements	Reference [I.10.1] Table 3.1-14 and Section 13.3.8	SER Advanced NUHOMS Amendment 0, Reference [I.10.5]	I.10.5	The canister is fabricated, inspected, tested, and maintained under the NUHOMS CoC (NRC Docket 72-1029) following the criteria described in the NUHOMS FSAR. Storage within the HI-STORM UMAX will not affect the acceptance tests and maintenance program since the canister shall already be fabricated and loaded prior to storage within the HI-STORM UMAX.

HOLTEC INTERNATIONAL COPYRIGHTED MATERIAL	
HI-2115090	Proposed Rev. 3.E
I.10-4	

I.10.1. ACCEPTANCE CRITERIA

This section provides the workmanship inspections and acceptance tests to be performed on the 24PT1-DSC canister, the HI-STORM UMAX, and the CHA-90 prior to loading of the system. These inspections and tests provide the assurance that all components are fabricated assembled, inspected, tested, and accepted for use under the conditions specified in the FSAR and the Certificate of Compliance issued by the NRC in accordance with the provisions of 10CFR72.

I.10.1.1. FABRICATION AND NONDESTRUCTIVE EXAMINATION

I.10.1.1.1. 24PT1-DSC

This section summarizes the fabrication and NDE requirements for the 24PT1-DSC canister.

I.10.1.1.1.1. FABRICATION REQUIREMENTS

The 24PT1-DSC canister is fabricated in accordance with the Final Safety Analysis Report for the Standardized Advanced NUHOMS Horizontal Modular Storage System for Irradiated Nuclear Fuel [I.10.1]. Chapter 9 of the NUHOMS FSAR [I.10.1] outlines the acceptance and maintenance criteria for the canister. 24PT1-DSC canisters in use for longer than 20 years are not permitted to be stored in the HI-STORM UMAX per this FSAR. Only canisters which have remained at the site at which they were loaded are permitted to be stored in the HI-STORM UMAX per this FSAR.

I.10.1.1.1.2. VISUAL INSPECTIONS AND MEASUREMENTS

All fabrication visual inspections and measurements shall be performed per the NUHOMS FSAR Section 9.1.1[I.10.1].

I.10.1.1.1.3. WELD EXAMINATION

Weld examinations shall be performed per the NUHOMS FSAR Section 9.1.2 [I.10.1].

I.10.1.1.2. HI-STORM UMAX

This section summarizes the fabrication and NDE requirements for the HI-STORM UMAX.

I.10.1.1.2.1. FABRICATION REQUIREMENTS

Fabrication of the UMAX shall be in accordance with Chapter 10 of this FSAR, and the HI-STORM UMAX drawing package (see FSAR Sections 1.5 and I.1.5).

The Top Seismic Restraint Assembly and other minor additional features added to the UMAX such as the pedestal for use with the 24PT1-DSC are fabricated per the requirements laid out in Chapter 10 of this FSAR and the details laid out in this supplement.

HOLTEC INTERNATIONAL COPYRIGHTED MATERIAL	
HI-2115090	Proposed Rev. 3.E
I.10-5	

I.10.1.1.2.2. VISUAL INSPECTIONS AND MEASUREMENTS

Visual inspections and Measurements of the UMAX shall be in accordance with Chapter 10 of this FSAR, and the HI-STORM UMAX drawing package (see FSAR Sections 1.5 and I.1.5).

The Top Seismic Restraint Assembly, Divider Shell Appurtenance Assembly, and other minor additional features added to the UMAX such as the pedestal for use with the 24PT1-DSC are to be visually inspected per the requirements laid out in Chapter 10 of this FSAR. Additionally the Top Seismic Restraint Assembly, Divider Shell Appurtenance Assembly shall have the following verified as part of visual inspections/measurements:

- The Top Seismic Restraint Assembly shall be inspected to confirm that the labeling is complete and legible.
- Divider Shell Appurtenance Assembly shall be inspected to confirm that the labeling is complete and legible.

I.10.1.1.2.3. WELD EXAMINATION

Weld Examinations of the UMAX and 24PT1-DSC supplementary features such as the Top Seismic Restraint Assembly, Pedestal, etc. shall be in accordance with Chapter 10 of this FSAR, and the HI-STORM UMAX drawing package (see FSAR Sections 1.5 and I.1.5).

I.10.1.1.3. CHA-90**I.10.1.1.3.1. FABRICATION REQUIREMENTS**

The manufacturing of the Canister Handling Apparatus (CHA-90) components shall be carried out in accordance with the CoC holder's NRC-approved QA program. All elements of the manufacturing cycle will be established to accord with the Important-to-Safety (ITS) designation of the specific part (indicated in the licensing drawing package, see FSAR Section I.1.5) and the applicable provisions of the referenced codes and standards. The acceptance criteria for the manufactured components apply to each step of the manufacturing evolution, namely (a) supplier selection, (b) preparation of material procurement specifications, (c) preparation of the shop traveler and fabrication procedures, (d) fabrication activities such as forming, bending, plasma cutting, and welding, (e) in-process inspections, (f) final inspection, (g) packaging for shipment, and (h) assembling of the documentation package to serve as the archival evidence of adherence to the quality requirements.

In order to receive the Certificate-of-Compliance under the CoC holder's QA program, the manufacturing of the CHA-90 components must meet all of the technical, quality control, procedural (quality assurance) and administrative requirements set forth in the manufacturing program.

- The materials of construction for the CHA-90 are identified in the drawing package (see FSAR Section I.1.5). Materials for ITS components shall be

HOLTEC INTERNATIONAL COPYRIGHTED MATERIAL	
HI-2115090	Proposed Rev. 3.E
I.10-6	

procured with certification and supporting documentation as required by the ASME Code, Section II, where applicable [10.1.1], Holtec procurement specifications, and 10CFR72 Subpart G. ITS components shall be receipt inspected for visual and dimensional acceptability, material conformance to specification requirements, and traceability markings, as applicable. Controls shall be in place to ensure that material traceability is maintained throughout fabrication. All materials (plates, bars, forgings, etc... as applicable) used in the construction of the CHA-90 shall be dimensionally inspected to assure compliance with the requirements on the drawing. Inspection results shall be documented and become part of the quality documentation package.

- The CHA-90 shall be inspected for cleanliness and proper packaging for shipping in accordance with approved procedures. Additionally the CHA-90 shall be durably marked with appropriate model number, unique identification number, weight, and maximum lifting load at the completion of the acceptance test program.
- A documentation package shall be prepared and maintained during fabrication of each CHA-90 to include detailed records and evidence that the required inspections and tests have been performed. The completed documentation package shall be reviewed to verify that the CHA-90 has been properly fabricated and inspected in accordance with the design and code construction requirements. The documentation package shall include, as applicable, but not limited to:
 - Completed Shop Weld Records
 - Inspection Records
 - Nonconformance Reports
 - Material Test Reports
 - NDE Reports
 - Dimensional Inspection Report

I.10.1.1.3.2. VISUAL INSPECTIONS AND MEASUREMENTS

The CHA-90 components shall be assembled in accordance with the licensing drawing (see FSAR Section I.1.5). The licensing drawing provides tolerances that define the limits on dimensions used in licensing basis analysis. Fabrication drawings provide the additional dimensional tolerances necessary to ensure the fit-up of parts. Visual inspections and measurements shall be made and controls exercised to ensure that the CHA-90 components conform to the dimensional restraints dictated on the licensing and fabrication drawings. These dimensions are subject to independent confirmation and documentation in accordance with the Holtec QA program approved in NRC Docket Number 71-0784.

I.10.1.1.3.3. WELD EXAMINATION

The examination of the CHA-90 system welds shall be performed in accordance with the licensing drawing (see FSAR Section I.1.5) and the applicable codes and standards. All

HOLTEC INTERNATIONAL COPYRIGHTED MATERIAL	
HI-2115090	Proposed Rev. 3.E
I.10-7	

structural weld inspections shall be performed in accordance with written and approved procedures by personnel qualified in accordance with SNT-TC-1A. Structural welds for the CHA-90 shall meet the acceptance criteria of ASME Section III, Subsection NF. All required inspections, examination, and tests shall become part of the final quality documentation package. Non-Structural weld inspections shall be performed by welders or weld inspectors qualified in accordance with written procedures. Non-Structural welds shall be free of cracks and other liner indications.

I.10.1.2. STRUCTURAL TESTS

The structural requirements for the 24PT1-DSC, HI-STORM UMAX and CHA-90 are described in following subparagraphs.

I.10.1.2.1. 24PT1-DSC

All structural and pressure tests required for the 24PT1-DSC shall be performed in accordance with the Advanced NUHOMS FSAR Sections 9.1.2 and 9.1.3 [I.10.1]

I.10.1.2.2. HI-STORM UMAX

All structural tests of the HI-STORM UMAX shall be in accordance with Chapter 10 of this FSAR. No additional tests are required for the supplementary features for the HI-STORM UMAX unless otherwise stated in the drawing package (see FSAR Sections 1.5 and I.1.5).

I.10.1.2.3. CHA-90

The CHA-90 is considered a Special Lifting Device per NUREG-0612 (Control of Heavy Loads at Nuclear Power plants)[I.10.2]. In accordance with NUREG-0612, all special lifting devices should satisfy the guidelines of ANSI N14.6 [I.10.3]. All structural load testing of the CHA-90 shall conform with NUREG-0612[I.10.2] and ANSI N14.6 [I.10.3] requirements (see Tables I.10.2 and I.10.4.1).

Section 5 of NUREG-0612[I.10.2] calls for measures to “provide an adequate defense-in-depth for handling of heavy loads...”. The NUREG-0612 guidelines cite four major causes of load handling accidents, of which rigging failure is one.

- i. Operator errors
- ii. Rigging failure
- iii. Lack of adequate inspection
- iv. Inadequate procedures

The cask handling operations program shall ensure maximum emphasis to mitigate the potential load drop accidents by implementing measures to eliminate shortcomings in all aspects of the operation including the four aforementioned areas.

HOLTEC INTERNATIONAL COPYRIGHTED MATERIAL	
HI-2115090	Proposed Rev. 3.E
I.10-8	

I.10.1.3. MATERIALS TESTING

The material testing requirements for the 24PT1-DSC, HI-STORM UMAX and CHA-90 are described in following subparagraphs.

I.10.1.3.1. MATERIAL TESTING REQUIREMENTS**I.10.1.3.1.1. 24PT1-DSC**

All material tests required for the 24PT1-DSC shall be performed in accordance with the Advanced NUHOMS FSAR Section 9.1.2 [I.10.1]

I.10.1.3.1.2. UMAX

All material tests of the HI-STORM UMAX shall be in accordance with Chapter 10 of this FSAR, and the supplementary HI-STORM UMAX drawing package (see FSAR Sections 1.5 and I.1.5). The supplementary features of the HI-STORM UMAX such as the Top Seismic Restraint Assembly or Divider Shell Appurtenance Assembly do not have any additional material testing requirements.

I.10.1.3.1.3. CHA-90

The steel material used in the CHA-90 will be tested in accordance with the requirements of the applicable ASME/ASTM material code requirements specified in the licensing drawing (see FSAR Section I.1.5). In addition to material code requirements, ANSI N14.6 Section 4.2.6 [I.10.3] requires load bearing materials be subjected to drop weight testing/Charpy testing unless otherwise exempted by the provisions laid out in the code. In replacement of the code specifications in ANSI N14.6 Section 4.2.6 [I.10.3], the CHA-90 materials shall be tested per Class 3 ASME Boiler and Pressure Vessel Code, Section III, Subsection NF-2300-Fracture Toughness Requirements For Material [I.10.4].

I.10.1.4. LEAKAGE TESTING

The leakage testing requirements for the 24PT1-DSC, HI-STORM UMAX and CHA-90 are described in following subparagraphs

I.10.1.4.1. LEAKAGE TESTING REQUIREMENTS**I.10.1.4.1.1. 24PT1-DSC**

All leakage testing required for the 24PT1-DSC shall be performed in accordance with the Advanced NUHOMS FSAR Section 9.1.3 [I.10.1]

I.10.1.4.1.2. HI-STORM UMAX

All Leakage Testing requirements of the HI-STORM UMAX shall be in accordance with Chapter 10 of this FSAR. No additional tests are required for the supplemental features such as the Top Seismic Restraint.

HOLTEC INTERNATIONAL COPYRIGHTED MATERIAL	
HI-2115090	Proposed Rev. 3.E
I.10-9	

I.10.1.4.1.3. CHA-90

No leakage testing is required for the CHA-90.

I.10.1.5. COMPONENT TESTS

There are no valves, pressure relief device and fluid transport devices associated with the 24PT1-DSC (NUHOMS FSAR Section 9.1.4 [I.10.4], HI-STORM UMAX and CHA-90.

I.10.1.6. SHIELDING INTEGRITY

The shielding requirements for the 24PT1-DSC, HI-STORM UMAX and CHA-90 are described in following subparagraphs.

I.10.1.6.1. SHIELDING INTEGRITY REQUIREMENTS

I.10.1.6.1.1. 24PT1-DSC

All shielding acceptance requirements for the 24PT1-DSC shall be in accordance with the Advanced NUHOMS FSAR Section 9.1.5 [I.10.1].

I.10.1.6.1.2. UMAX

All shielding acceptance requirements of the HI-STORM UMAX shall be in accordance with Chapter 10 of this FSAR. The supplemental features of the HI-STORM UMAX have no further shielding requirements.

I.10.1.6.1.3. CHA-90

The CHA-90 does not perform shielding functions and has no shielding requirements.

I.10.1.7. THERMAL ACCEPTANCE TESTS

The Thermal Acceptance tests for the 24PT1-DSC, HI-STORM UMAX and CHA-90 are described in following subparagraphs.

I.10.1.7.1. THERMAL ACCEPTANCE REQUIREMENTS

I.10.1.7.1.1. 24PT1-DSC

All thermal acceptance requirements for the 24PT1-DSC shall be in accordance with the Advanced NUHOMS FSAR Section 9.1.6 [I.10.1]

I.10.1.7.1.2. UMAX

All thermal acceptance requirements of the HI-STORM UMAX shall be in accordance with Chapter 10 of this FSAR, and the supplementary HI-STORM UMAX drawing package (see FSAR Sections 1.5 and I.1.5).

HOLTEC INTERNATIONAL COPYRIGHTED MATERIAL	
HI-2115090	Proposed Rev. 3.E
I.10-10	

Thermal performance of the supplemental features of the HI-STORM UMAX is demonstrated through analysis in Supplement I.4 and Chapter 4 of this FSAR. Dimensional inspections to verify the items have been fabricated to the dimensions provided in the drawings shall be performed prior to system loading.

I.10.1.7.1.3. CHA-90

The thermal performance of the CHA-90 is demonstrated through analysis in Chapter I.4 of this FSAR supplement. Dimensional inspections to verify the item has been fabricated to the dimensions provided in the drawings shall be performed prior to use of the CHA-90.

HOLTEC INTERNATIONAL COPYRIGHTED MATERIAL	
HI-2115090	Proposed Rev. 3.E
I.10-11	

Table I.10.1.1
CHA-90 ASSEMBLY INSPECTION AND TEST ACCEPTANCE CRITERIA

Function	Fabrication	Pre-Operation	Maintenance Operation
Visual Inspection and Non-destructive Examination (NDE)	Inspections per fabrication drawing	See table I.10.4.1	See table I.10.4.1
Structural	Verification of structural materials shall be performed through receipt inspection	An initial load test is required Per ANSI N14.6 [I.10.3]; See Table I.10.1.2	See Table I.10.4.1
Identification	Verify Identification is present in accordance with the drawings shall be performed upon completion of the assembly	Identification shall be checked prior to use.	Periodic inspections of the identification shall be performed and the identification shall be repaired or replaced if damaged.
Fit-up Tests	Where closely toleranced alignment between mating components is required, a component-to-component fit-up shall be performed directly whenever practical or using templates or other means.	A functional fit-up with the HI-TRAC and a mock DSC shall be performed prior to initial use.	None.

HOLTEC INTERNATIONAL COPYRIGHTED MATERIAL

HI-2115090	Proposed Rev. 3.E
I.10-12	

Table I.10.1.2 CHA-90 LOAD TESTING REQUIREMENTS	
REQUIREMENT	DURATION
300% of Design Load	10 Minutes

Table I.10.1.3 CHA-90 CHARPY/DROP WEIGHT TEST REQUIREMENTS			
Test	NIL Ductility Temperature Criteria	Absorbed Energy Criteria	Lateral Expansion Criteria
Ferritic materials for load-bearing members shall be subjected to a Drop Weight Test or a Charpy Impact Test *	At least 40°F (22°C) below the anticipated minimum service temperature.	In accordance with Figure NF-2331 (a)-2 or as documented in the Holtec calculation package.	Per Table NF-2331 (a)-3
*Unless exempted by NF-2311[I.10.4]			

HOLTEC INTERNATIONAL COPYRIGHTED MATERIAL	
HI-2115090	Proposed Rev. 3.E
I.10-13	

I.10.2. SITE CONSTRUCTION

All HI-STORM UMAX site construction activities shall conform to the requirements of Chapter 10 (Section 10.2) of this FSAR. The 24PT1-DSC and the CHA90 are not constructed at site and thus have no site construction requirements.

HOLTEC INTERNATIONAL COPYRIGHTED MATERIAL	
HI-2115090	Proposed Rev. 3.E
I.10-14	

I.10.3. INSPECTION AND TESTING

The Inspection and Testing requirements for the 24PT1-DSC, HI-STORM UMAX and CHA-90 are described in following subparagraphs.

I.10.3.1. 24PT1-DSC

All Inspection and Testing requirements for the 24PT1-DSC shall be in accordance with the Advanced NUHOMS FSAR Section 9.2 [1.10.1]. No additional testing is required for use with the HI-STORM UMAX due to the 20 year lifespan limit and off-site transport restriction on the 24PT1-DSC canister.

I.10.3.2. HI-STORM UMAX

All inspection and testing requirements of the HI-STORM UMAX shall be in accordance with Chapter 10 of this FSAR. The Top Seismic Restraint Assembly, Divider Shell Appurtenance Assembly, and other supplemental features do not have any additional testing and inspection requirements.

I.10.3.3. CHA-90

I.10.3.3.1. Functional Test:

After assembly of the CHA-90, functional tests shall be performed to ensure the assembly is working as intended.

[

PROPRIETARY INFORMATION WITHHELD PER 10CFR2.390

]

I.10.3.3.2. Load Test:

A load test (requirements described in table I.10.1.2) shall be performed after construction and prior to loading to ensure the CHA-90 meets the appropriate structural requirements.

HOLTEC INTERNATIONAL COPYRIGHTED MATERIAL	
HI-2115090	Proposed Rev. 3.E
I.10-15	

I.10.4. MAINTENANCE PROGRAM

This section delineates the maintenance requirements of the 24PT1-DSC, HI-STORM UMAX and CHA-90 are described in following subparagraphs.

I.10.4.1. 24PT1-DSC

24PT1-DSC canisters in use for longer than 20 years or canisters transported from the site in which were initially loaded are not permitted to be stored in the HI-STORM UMAX per this FSAR. Per the NUHOMS FSAR (Section 9.2[1.10.1]) the 24PT1-DSC does not require any maintenance once loaded and stored. Due to the restrictions on transport and age of the canister, no maintenance is required once the 24PT1-DSC is stored in a HI-STORM UMAX.

I.10.4.2. HI-STORM UMAX

All maintenance requirements of the HI-STORM UMAX shall be in accordance with Chapter 10 (Section 10.4) of this FSAR. No additional maintenance is required for the HI-STORM UMAX supplemental features.

I.10.4.3. CHA-90

An ongoing maintenance program shall be defined and incorporated into the CHA-90 Operations and Maintenance Manual, which shall be prepared and issued prior to the first use of the system by a user. This document shall delineate the detailed inspections, testing, and parts replacement necessary to ensure continued structural and thermal performance in accordance with the conditions in the Certificate of Compliance and design requirements and criteria contained in this FSAR.

The CHA-90 shall be tested to verify continual compliance with the prescribed requirements in this FSAR and ANSI N14.6 [I.10.3] throughout the life of the equipment. See table I.10.4.1 for maintenance schedule.

HOLTEC INTERNATIONAL COPYRIGHTED MATERIAL	
HI-2115090	Proposed Rev. 3.E
I.10-16	

Table I.10.4.1		
CHA-90 MAINTENANCE PROGRAM SCHEDULE		
Task	Frequency	Comments
Load Testing	Annually (not to exceed 14 months)	If the CHA-90 has not been used for a period exceeding one year, the load testing shall not be required. However, in this event, the test shall be applied before returning the device to service.
	Following any major maintenance or alteration.	Major maintenance or alteration is defined as a repair or design change in which load-bearing members are subjected to heating above 300°F.
	Following any incident in which any of the load bearing components may have been subjected to stresses substantially in excess of those for which it has been qualified by previous testing, or following an incident that may have caused permanent distortion of its load bearing parts.	
Visual Inspection by operational personnel	Prior to each use	Inspect for indications of damage or deformation.
Visual Inspection by maintenance or non-operational personnel	Intervals not to exceed three months	Inspect for indications of damage or deformation. If the CHA-90 has not been used for a period exceeding one year, the visual inspection shall not be required. However, in this event, the inspection shall be applied before returning the device to service.
Functional Test	Annually (not to exceed 14 months)	If the CHA-90 has not been used for a period exceeding one year, the functional test shall not be required. However, in this event, the test shall be applied before returning the device to service.
	Following any incident in which repairs or alterations have been required on non-load-bearing functioning components or in which the CHA-90 has suffered detectable distortion.	

HOLTEC INTERNATIONAL COPYRIGHTED MATERIAL

HI-2115090

Proposed Rev. 3.E

I.10-17

I.10.5. CASK IDENTIFICATION

I.10.5.1. 24PT1-DSC

All marking requirements for the 24PT1-DSC shall be in accordance with the Advanced NUHOMS FSAR Table 3.1-14 and Section 13.3.8 [1.10.1]

I.10.5.2. HI-STORM UMAX

All marking requirements of the HI-STORM UMAX shall be in accordance with Chapter 10 (Section 10.5) of this FSAR. Supplemental features such as the Divider Shell Appurtenance Assembly shall be marked with unique identifying features for traceability.

I.10.5.3. CHA-90

The CHA-90 shall be marked with a durable identifier. It shall be marked with a unique identification number, weight, and maximum lifting load at the completion of the acceptance test program.

HOLTEC INTERNATIONAL COPYRIGHTED MATERIAL	
HI-2115090	Proposed Rev. 3.E
I.10-18	

I.10.6. REGULATORY COMPLIANCE

The information presented in this section fulfills the regulatory requirements pertaining to the testing and maintenance of the 24PT1-DSC, HI-STORM UMAX, and CHA-90, resolution of issues concerning adequacy and reliability, and cask identification. This section demonstrates the compliance information on the 24PT1-DSC, HI-STORM UMAX, and CHA-90.

I.10.6.1.1. 24PT1-DSC

All requirements for regulatory compliance for the 24PT1-DSC shall be in accordance with the Advanced NUHOMS FSAR [1.10.1]

I.10.6.1.2. HI-STORM UMAX

The regulatory compliance of the HI-STORM UMAX is laid out in Chapter 10 FSAR. The supplemental HI-STORM UMAX features have no additional regulatory compliance requirements.

I.10.6.1.3. CHA-90

The CHA-90 is used solely for on-site transfer and must meet the requirements of NUREG-0612[I.10.2]/ANSI N14.6[I.10.3] for special lifting devices for radioactive materials.

HOLTEC INTERNATIONAL COPYRIGHTED MATERIAL	
HI-2115090	Proposed Rev. 3.E
I.10-19	

I.10.7. REFERENCES

- [I.10.1] [AREVA Inc. \(formerly Transnuclear, Inc.\), “Updated Final Safety Analysis Report for the Standardized Advanced NUHOMS Horizontal Modular Storage System for Irradiated Nuclear Fuel Report No. ANUH 01.0150”, Revision 6 \(Non-Proprietary Version\), Docket 72-1029, August 2014. Compiled from ML050410252, ML031040379, ML031040312, ML040910311, ML082341022, ML102290084, ML12229A121, and ML14226A790](#)

- [I.10.2] [U.S. Nuclear Regulatory Commission , “NUREG-0612, Control of Heavy Loads at Nuclear Power Plants”,_ 1980.](#)

- [I.10.3] [American National Standards Institute “American National Standard for Radioactive Materials – Special Lifting Devices for Shipping Containers Weighing 10,000 Pounds \(4,500 Kg\) or More”, ANSI/ANS N14.6-1993, New York, New York.](#)

- [I.10.4] American Society of Mechanical Engineers, “Boiler and Pressure Vessel Code,” Sections II, III, V, IX, and XI, 2010 Edition.

- [I.10.5] [U.S. Nuclear Regulatory Commission, “Final Safety Evaluation Report Transnuclear, Inc. Standardized Advanced NUHOMS Horizontal Modular Storage System for Irradiated Nuclear Fuel”, Amendment No. 3, Docket 72-1029, February 20, 2015.](#)

HOLTEC INTERNATIONAL COPYRIGHTED MATERIAL	
HI-2115090	Proposed Rev. 3.E
I.10-20	

CHAPTER I.11: RADIATION PROTECTION

I.11.0 INTRODUCTION

The design considerations and operational features that are incorporated in the HI-STORM UMAX system to protect plant personnel and the public from exposure to radioactive contamination and ionizing radiation during handling of the loaded 24PT1-DSCs at the ISFSI are bounded by those covered in Chapter 11 of this UMAX FSAR with the loaded MPCs.

Operational crew dose per canister is expected to be lower than the crew doses presented in Table 11.3.1 and Table 11.3.2 since many of the operational tasks have already been completed for the 24PT1-DSCs, and dose rates for both the HI-TRAC and UMAX will be lower for fully loaded 24PT1-DSC as discussed in Supplement I.5.

Since the determination of off-site doses is necessarily site-specific, more detailed dose assessment may be prepared by the licensee as part of implementing the HI-STORM UMAX System in accordance with 10CFR72.212 [11.0.2].

HOLTEC INTERNATIONAL COPYRIGHTED MATERIAL	
HI-2115090	Rev. 3.E
HI-STORM UMAX Supplement I Rev 3I	227101 282
April 2020	

SUPPLEMENT I.12: ACCIDENT EVALUATION

I.12.0 INTRODUCTION

Supplement I adds the 24PT1-DSC canister to the HI-STORM UMAX system [I.1.2.1]. Only those design features of “UMAX” that are revised or added to incorporate the 24PT1-DSC canister are described in this chapter. This chapter also references to the main body of the FSAR where existing safety analyses are bounding, as applicable. The material in this supplement is organized to mirror the corresponding material in the main body of the FSAR with the letter I. inserted before each chapter/section/subsection/paragraph number. Thus the numeric sequence I.m.n.p.r indicates that the material belongs to Supplement I, Chapter #m, Section #n , subsection# p and paragraph # r. (m, n, p and r are numeric values). Thus, the numbering of the material in the supplement is readily distinguished from the main FSAR’s while the content correspondence is maintained.

The 24PT1-DSC canister is approved by the NRC for storage under Part 72, Docket No. 72-1029. The applicable safety analysis information is incorporated by reference to the NUHOMS FSAR [I.1.2.1]. A roadmap of the referenced information is tabulated in Table I.12.0.1.

This chapter is focused on the safety evaluation of all off-normal and accident events germane to the HI-STORM UMAX vertical ventilated module (VVM) containing a loaded 24PT1-DSC. For each postulated event, the event cause, means of detection, consequences, and corrective actions, as applicable, are discussed and evaluated. For other miscellaneous events (i.e., those not categorized as either design basis off-normal or accident condition events), a similar outline for safety analysis is followed. As applicable, the evaluation of consequences includes the impact on the structural, thermal, shielding, criticality, confinement, and radiation protection performance of the system due to each postulated event.

The structural, thermal, shielding, criticality, and confinement features and performance of the HI-STORM UMAX system under the short-term operations and various conditions of storage are evaluated in Supplements I.3, I.4, I.5, I.6, and I.7. The evaluations provided in this supplement are supported by the design features and analyses reported therein. The accidents considered in this chapter follow the guidance in NUREG-1536.

HOLTEC INTERNATIONAL COPYRIGHTED MATERIAL	
HI-2115090	Proposed Rev. 3.E
I.12-1	

Table I.12.0.1: Material Incorporated by Reference

Information Incorporated by Reference	Source of the Information	NRC Approval of Material Incorporated by Reference	Location in this FSAR where Material is Incorporated by Reference	Technical Justification of Applicability to HI-STORM UMAX
NUHOMS Canister welded closure integrity evaluation.	NUHOMS FSAR Reference [I.1.2.1, Chapter 3, Para 3.1.1.1]	NUHOMS SER Reference [I.1.2.2]	I.12.2	The canister is the same as the one described in the FSAR and originally approved in the referenced SER.
NUHOMS Canister Reflood	NUHOMS FSAR Reference [I.1.2.1, Chapter 3, Section 3.5.4]	NUHOMS SER Reference [I.1.2.2]	I.12.3	The canister is the same as the one described in the FSAR and originally approved in the referenced SER.
Canister Design Pressure	NUHOMS FSAR Reference [I.1.2.1, Chapter 3, Table 3.1-6]	NUHOMS SER Reference [I.1.2.2]	I.12.1 I.12.2	The canister is the same as the one described in the FSAR and originally approved in the referenced SER.
Canister in NUHOMS Transfer Cask fire accident evaluation	NUHOMS FSAR Reference [I.1.2.1, Chapter 4, Subsection 4.6.4]	NUHOMS SER Reference [I.1.2.2]	I.12.2	The canister is the same as the one described in the FSAR and originally approved in the referenced SER.

HOLTEC INTERNATIONAL COPYRIGHTED MATERIAL	
HI-2115090	Proposed Rev. 3.E
I.12-2	

I.12.1 OFF-NORMAL CONDITIONS

Off-normal conditions, as defined in accordance with ANSI/ANS-57.9, are those conditions which, although not occurring regularly, are expected to occur no more than once a year. In this section, design events pertaining to off-normal operation for expected operational occurrences are considered. The off-normal conditions are defined in Subsection I.2.2.3.

The following off-normal events are applicable to the HI-STORM UMAX system:

- Off-Normal Pressure
- Off-Normal Environmental Temperature
- Leakage of One Seal
- Partial Blockage of the Air Inlet Plenum
- Hypothetical Non-Quiescent Wind
- FHD Malfunction

The results of the evaluations presented herein demonstrate that the HI-STORM UMAX System can withstand the effects of off-normal events and remain in compliance with the applicable acceptance criteria.

I.12.1.1 Off-Normal Pressure

The sole pressure boundary in the HI-STORM UMAX Storage System is the 24PT1-DSC enclosure vessel. The off-normal pressure condition is specified in Section I.2.2. The 24PT1-DSC pressure is a function of the helium backfill pressure and the steady state temperature reached under normal storage temperatures. The off-normal condition is evaluated with 10% of the fuel rods ruptured and with 100% of ruptured rods fill gas and 30% of ruptured rods fission gases released to the cavity.

I.12.1.1.1 Postulated Cause of Off-Normal Pressure

The 24PT1-DSC is stored in an inert gas (helium) filled environment to assure long-term cladding integrity during dry storage. The probability of failure of intact fuel rods in dry storage is extremely low. As defense-in-depth the event is postulated and evaluated.

I.12.1.1.2 Detection of Off-Normal Pressure

The HI-STORM UMAX system is designed to withstand the 24PT1-DSC off-normal internal pressure without any effects on its ability to meet its safety requirements. There is no requirement or safety imperative for detection of off-normal pressure and, therefore, no monitoring is required.

HOLTEC INTERNATIONAL COPYRIGHTED MATERIAL	
HI-2115090	Proposed Rev. 3.E
I.12-3	

I.12.1.1.3 Analysis of Effects and Consequences of Off-Normal Pressure

The 24PT1-DSC off-normal internal pressure is evaluated in Section I.4.6.1.3 under design basis heat load. The 24PT1-DSC pressure remains below NUHOMS FSAR Table 3.1-6 limits.

i. Structural

Structural evaluation of the 24PT1-DSC under off-normal pressures is addressed under service loads Section I.2.2 in Supplement I.2.

ii. Thermal

The canister internal pressure under off-normal conditions tabulated in Table I.4.4.6 remains below 24PT1-DSC pressure limits specified in NUHOMS FSAR Table 3.1-6 [I.1.2.1].

iii. Shielding

There is no effect on the shielding performance of the system as a result of this off-normal event.

iv. Criticality

There is no effect on the criticality control features of the system as a result of this off-normal event.

v. Confinement

There is no effect on the 24PT1-DSC confinement function. As evaluated above, the computed pressures remain below the design pressures evaluated in Supplement I.2 for compliance with ASME Pressure Vessel Code.

vi. Radiation Protection

Since there is no degradation in shielding or confinement capabilities as discussed above, there is no effect on occupational or public exposures as a result of this off-normal event.

I.12.1.1.4 Corrective Action for Off-Normal Pressure

The HI-STORM UMAX system is designed to withstand the off-normal pressure without any effects on its ability to maintain safe storage conditions. Therefore, there is no corrective action requirement for off-normal pressure.

HOLTEC INTERNATIONAL COPYRIGHTED MATERIAL	
HI-2115090	Proposed Rev. 3.E
I.12-4	

I.12.1.1.5 Radiological Impact of Off-Normal Pressure

The event of off-normal pressure has no radiological impact because the confinement barrier and shielding integrity are not affected.

I.12.1.1.6 Conclusion

Based on this evaluation, it is concluded that the off-normal pressure does not affect the safe operation of the HI-STORM UMAX system.

I.12.1.2 Off-Normal Environmental Temperatures

The HI-STORM UMAX System is designed for use at any site in the United States. Off-normal environmental temperatures have been conservatively selected to bound the environmental temperatures at all candidate sites in the United States (See Section I.2.2 for definition of the term off-normal environmental temperature).

I.12.1.2.1 Postulated Cause of Off-Normal Environmental Temperatures

The off-normal environmental temperature is postulated as a constant elevated ambient temperature caused by extreme weather conditions. To determine the effects of the off-normal temperatures, it is conservatively assumed that these temperatures persist for a sufficient duration to allow the HI-STORM UMAX System to achieve thermal equilibrium. Because of the large mass of the HI-STORM UMAX System with its corresponding large thermal inertia and the limited duration for the off-normal temperatures, this assumption is conservative.

I.12.1.2.2 Detection of Off-Normal Environmental Temperatures

The HI-STORM UMAX System is designed to withstand the off-normal environmental temperatures without affecting its ability to maintain safe storage conditions. There is no requirement for detection of off-normal environmental temperatures for the HI-STORM UMAX System. The limitations on the use of the transfer cask for loading canisters in the HI-STORM UMAX system under off-normal thermal conditions are contained in Section 12.1.2 of the HI-STORM FW FSAR which must be observed.

I.12.1.2.3 Analysis of Effects and Consequences of Off-Normal Environmental Temperatures

The off-normal event is considered to be characterized by an off-normal environmental temperature with insolation for sufficient duration to reach thermal equilibrium. The evaluation is performed under design basis heat load. The Off-Normal ambient temperature condition is evaluated in Subsection I.4.6.1. The results are in compliance with off-normal pressure and temperature limits in NUHOMS FSAR Table 3.1-6 and Supplement I.2, Table I.2.2.1 respectively.

HOLTEC INTERNATIONAL COPYRIGHTED MATERIAL	
HI-2115090	Proposed Rev. 3.E
I.12-5	

The off-normal event considering an environmental temperature of -40°F and no solar insolation for a sufficient duration to reach thermal equilibrium is evaluated with respect to material design temperatures of the HI-STORM UMAX VVM. The HI-STORM UMAX VVM structure is conservatively assumed to reach the extreme cold condition (-40°F) throughout its body. The qualification of the VVM structure under the extreme cold condition is provided in the main body of the FSAR in Chapter 8.

i. Structural

The principal effect under Off-Normal ambient temperatures is increased 24PT1-DSC pressure. As evaluated in Subsection I.4.6.1, the pressure under Off-Normal temperature complies with off-normal design pressure (NUHOMS FSAR Table 3.1-6). The effect of lowerbound off-normal thermal conditions (i.e., -40°F) requires an evaluation of the potential for brittle fracture. This requirement is evaluated in Supplement I.8.

ii. Thermal

The resulting off-normal system and fuel cladding temperatures for the hot conditions are evaluated in Subsection I.4.6.1. This evaluation confirms fuel, canister and VVM temperatures comply with off-normal design limits. The increased pressure coincident with Off-Normal ambient storage temperatures remain within off-normal design limits. The evaluation above supports assurance of safe storage under Off-Normal environmental temperature.

iii. Shielding

There is no effect on the shielding performance of the system as a result of this off-normal event.

iv. Criticality

There is no effect on the criticality control features of the system as a result of this off-normal event.

v. Confinement

There is no adverse effect on the confinement function of the 24PT1-DSC. As discussed in the structural evaluation above, confinement boundary pressure remains below structural limits designed to comply with ASME Pressure Vessel Code. In this manner Confinement Boundary integrity is reasonably assured.

HOLTEC INTERNATIONAL COPYRIGHTED MATERIAL	
HI-2115090	Proposed Rev. 3.E
I.12-6	

vi. Radiation Protection

Since there is no degradation in shielding or confinement capabilities as discussed above, there is no effect on occupational or public exposures as a result of this off-normal event.

I.12.1.2.4 Corrective Action for Off-Normal Environmental Temperatures

The HI-STORM UMAX System is designed to withstand the off-normal environmental temperatures without any effects on its ability to maintain safe storage conditions. As required by the HI-STORM FW FSAR [I.1.2.3], appropriate precautions must be observed under cold weather conditions to prevent freezing of water in the HI-TRAC VW transfer cask. There are no corrective actions required for off-normal environmental temperatures.

I.12.1.2.5 Radiological Impact of Off-Normal Environmental Temperatures

Off-normal environmental temperatures have no radiological impact, as the confinement barrier and shielding integrity are not affected.

I.12.1.2.6 Conclusion

Based on the above evaluation, it is concluded that the specified off-normal environmental temperatures do not affect the safe operation of the HI-STORM UMAX System.

I.12.1.3 Leakage of One 24PT1-DSC Seal Weld

NUHOMS FSAR 24PT1-DSC welded closure integrity evaluation [I.1.2.1] supports the conclusion that leakage from the confinement boundary is non-credible. The evaluation is incorporated by reference (See Table I.12.0.1).

I.12.1.4 Partial Blockage of Air Inlet Plenum

Partial blockage (50%) of the air intake system has been postulated as an off-normal event in Section I.2.2.

The HI-STORM UMAX intake ducts are designed with debris screens, as is the outlet vent flue located in the Closure Lid. These screens protect the openings from the incursion of foreign objects. However, as required by the design criteria presented in Supplement I.2, it is conservatively assumed that 50% of the air inlet opening is completely blocked. The scenario of the partial blockage of air inlets is evaluated with a normal ambient temperature (Section I.2.2), insolation, and Design Basis SNF decay heat. This condition is analyzed in Section I.4.6 to demonstrate the acceptability of the system thermal performance during this event.

HOLTEC INTERNATIONAL COPYRIGHTED MATERIAL	
HI-2115090	Proposed Rev. 3.E
I.12-7	

I.12.1.4.1 Postulated Cause of Partial Blockage of Air Inlets

The presence of screens prevents foreign objects from entering the openings and the screens are either inspected periodically or the system temperature field is monitored per the technical specifications. It is, however, possible that blowing debris may partially block the inlet openings for a short time until the openings are cleared of debris.

I.12.1.4.2 Detection of Partial Blockage of Air Inlet

The detection of the partial blockage of air inlet openings will occur during the routine visual inspection of the screens or temperature monitoring of the outlet air required by the technical specifications. The frequency of inspection is based on an assumed complete blockage of all air inlet openings. Inspection requirement for partial inlet blockage is not proposed because complete blockage of all air inlet openings is bounding.

I.12.1.4.3 Analysis of Effects and Consequences of Partial Blockage of Air Inlets

i. Structural

The effect of partial blockage of the air inlet plenum on the 24PT1-DSC is an increase in component and fuel cladding temperatures and internal pressure. The resultant temperatures and pressures are below the off-normal design limits as evaluated in the thermal effects below. The evaluation supports the conclusion that structural integrity of the 24PT1-DSC is not affected.

ii. Thermal

The thermal evaluation of partial blockage of air inlet is discussed in Subsection I.4.6.1. The temperatures are conservatively computed as a 50% blockage of sufficient duration to reach the asymptotic maximum (steady-state) temperatures. The temperatures and coincident confinement boundary pressure comply with Supplement I.2 off-normal design limits (See Table I.4.6.1). The evaluation concludes no adverse effect on the UMAX thermal function.

iii. Shielding

There is no adverse effect on the function of shielding features of storage the system as a result of this off-normal event.

iv. Criticality

There is no effect on the criticality control features of the system as a result of this off-normal event.

HOLTEC INTERNATIONAL COPYRIGHTED MATERIAL	
HI-2115090	Proposed Rev. 3.E
I.12-8	

v. Confinement

There is no effect on the confinement function of the 24PT1-DSC as a result of this off-normal event.

vi. Radiation Protection

Since there is no degradation in shielding or confinement capabilities as discussed above, there is no predicted adverse effect on occupational or public exposures as a result of this off-normal event.

I.12.1.4.4 Corrective Action for Partial Blockage of Air Inlets

Corrective action for the partial blockage of air inlet openings is covered by periodic inspection and blockage clearance requirements under 100% blockage event. After clearing of the blockage, the storage module temperatures returns to normal operating temperatures evaluated in Supplement I.4.

Periodic inspection of the HI-STORM UMAX vent screens is required per the technical specifications. Alternatively, as allowed by technical specifications, the outlet air temperature is monitored. The frequency of inspection is based on an assumed blockage of all air inlet openings.

I.12.1.4.5 Radiological Impact of Partial Blockage of Air Inlets

The off-normal event of partial blockage of the air inlet opening has no radiological impact because the confinement barrier is not breached and the system's shielding effectiveness is not diminished.

I.12.1.4.6 Conclusion

Based on the above evaluation, it is concluded that the off-normal partial blockage of air inlet ducts event does not affect the safe operation of the HI-STORM UMAX VVM.

I.12.1.5 Hypothetical Non-Quiescent Wind

The principal effect of wind is on the thermal performance of UMAX System. As evaluated in Subsection I.4.4.10 wind does not affect safe operating temperatures of the UMAX System.

I.12.1.6 FHD Malfunction

FHD is not relied for 24PT1-DSC storage in the UMAX System, therefore this event is not applicable.

HOLTEC INTERNATIONAL COPYRIGHTED MATERIAL	
HI-2115090	Proposed Rev. 3.E
I.12-9	

I.12.2 ACCIDENT EVENTS

Accidents, in accordance with ANSI/ANS-57.9, are either infrequent events that could reasonably be expected to occur during the lifetime of the HI-STORM UMAX system or events postulated because their consequences may affect the public health and safety. Sections I.2.3 and I.2.4, respectively, define the structurally and thermally significant loadings that are classified design basis accidents. These events have been evaluated in this FSAR to quantify the safety margins in the storage system.

The load combinations evaluated for postulated accident conditions are defined in Supplement I.2. The structural qualification of accidents is provided in Supplement I.3.

The following accident events germane to the safety evaluation of HI-STORM UMAX system are identified by reference to Sections I.2.3 and I.2.4:

- Fire Accident
- Tornado
- Flood
- Earthquake
- 100% Fuel Rod Rupture
- Confinement Boundary Leakage
- Explosion
- 100% Blockage of Air Inlets
- Burial Under Debris
- Extreme Environmental Temperature
- HI-TRAC VW Transfer Cask Handling Accident

The results of the evaluations performed in this FSAR demonstrate that the HI-STORM UMAX storage system can withstand the effects of all credible and hypothetical accident conditions and natural phenomena without affecting its safety function. In the following, the evaluation of the design basis postulated accident conditions and natural phenomena is presented which demonstrates that the requirements of 10CFR72.122 and of 10 CFR72.106(b) and 10CFR20 are met.

I.12.2.1 Design Basis Fire Event (Load Case 5 in Section I.2.3)

I.12.2.1.1 Cause of Fire

The potential of a fire accident near an ISFSI pad is rendered as extremely remote by ensuring that there are no combustible materials in the area. The only credible concern is related to a transport vehicle fuel tank fire engulfing a loaded HI-STORM UMAX VVM or a HI-TRAC VW transfer cask.

HOLTEC INTERNATIONAL COPYRIGHTED MATERIAL	
HI-2115090	Proposed Rev. 3.E
I.12-10	

I.12.2.1.2 Fire Analysis**(a) UMAX Fire**

The HI-STORM UMAX System must withstand elevated temperatures under the Design Basis Fire event defined in Table 2.3.1. The acceptance criteria for the fire accident are provided in Section 2.3 and the thermal analysis is contained in Section 4.6.2.1.

i. Structural

The effect of the fire accident on the HI-STORM UMAX system is an increase in fuel cladding and system component temperatures and 24PT1-DSC internal pressure. The structural integrity of the UMAX System is unaffected as the fire accident temperatures and pressures remain below the accident design limits as evaluated below.

ii. Thermal

As evaluated in Supplement I.4, the effect of the licensing basis fire accident does not challenge the integrity of stored fuel and 24PT1-DSC pressure boundary.

iii. Shielding

The loss of shielding, if any, has been determined by bounding calculations to be of insignificant consequence in Supplement I.4. With respect to concrete damage from a fire, NUREG-1536 (4.0,V,5.b) states: "the loss of a small amount of shielding material is not expected to cause a storage system to exceed the regulatory requirements in 10 CFR 72.106 and, therefore, need not be estimated or evaluated in the FSAR.

Less than 5% of the Closure Lid concrete thickness is computed to exceed the short-term temperature limit. The effect of this small amount of degraded shielding does not materially affect shielding.

iv Criticality

There is no effect on the criticality control features of the system as a result of this event.

HOLTEC INTERNATIONAL COPYRIGHTED MATERIAL	
HI-2115090	Proposed Rev. 3.E
I.12-11	

v. Confinement

There is no effect on the confinement function of the 24PT1-DSC as a result of this event since the structural integrity of the confinement boundary is unaffected.

vi. Radiation Protection

Since there is minimal reduction, if any, in shielding and no effect on the confinement capabilities as discussed above, there is no effect on occupational or public exposures as a result of this accident event.

(b) HI-TRAC VW Fire

To demonstrate fuel cladding and 24PT1-DSC pressure boundary integrity under an exposure to a fire accident a thermal analysis of the loaded HI-TRAC VW transfer cask is performed. The analysis for the fire accident including the methodology has been provided in Subsection I.4.6.2.

i. Structural

Structural integrity of 24PT1-DSC is not affected as the fire accident temperatures and pressures evaluated under thermal effects remain below design limits.

ii. Thermal

The thermal analysis of the 24PT1-DSC in the HI-TRAC VW transfer cask under a fire accident is performed in Subsection I.4.6.2. The analysis shows that the 24PT1-DSC internal pressure and fuel temperature increases remain within accident limits with robust margins. The analysis supports the conclusion that integrity of the stored fuel and confinement boundary is reasonably assured.

iii. Shielding

As evaluated in shielding Supplement I.5 the dose consequences of a fire accident under conservatively assumed loss of all jacket water are bounded by the main body of the UMAX FSAR.

iv. Criticality

There is no effect on the criticality control features of the system as a result of this event.

v. Confinement

There is no effect on the confinement function of the 24PT1-DSC as a result of this event, since the internal pressure does not exceed the accident condition design pressure

HOLTEC INTERNATIONAL COPYRIGHTED MATERIAL	
HI-2115090	Proposed Rev. 3.E
I.12-12	

and the 24PT1-DSC Confinement Boundary temperatures do not exceed the short-term allowable temperature limits.

vi. Radiation Protection

There is no degradation in confinement capabilities of the 24PT1-DSC, as discussed above. Increases in the local dose rates adjacent to the water jacket are evaluated in Chapter 5. Immediately after the fire accident a radiological inspection of the HI-TRAC VW transfer cask shall be performed and temporary shielding shall be installed if necessary to limit exposure to site personnel.

I.12.2.1.3 Fire Accident Corrective Actions

Upon detection of a fire adjacent to a loaded HI-TRAC VW transfer cask or HI-STORM UMAX VVM, the ISFSI owner shall take the appropriate immediate actions necessary to extinguish the fire. Fire fighting personnel should take appropriate radiological precautions, particularly with the HI-TRAC VW transfer cask as the water jacket rupture discs may open with resulting water loss and increase in radiation doses. Following the termination of the fire, a visual and radiological inspection of the equipment shall be performed.

As appropriate, temporary shielding around the HI-TRAC VW transfer cask shall be installed. Specific attention shall be taken during the inspection of the water jacket of the HI-TRAC VW transfer cask. If damage to the HI-TRAC VW transfer cask is limited to the loss of water in the water jacket due to the pressure increase, the water may be replaced. If damage to the HI-TRAC VW transfer cask is extensive and/or radiological conditions require (based on dose rate measurements), the HI-TRAC VW transfer cask shall be unloaded in accordance with Supplement I.9, prior to repair.

If damage to the UMAX VVM as the result of a fire event is widespread and/or as radiological conditions require (based on dose rate measurements), the 24PT1-DSC shall be removed from the UMAX VVM in accordance with Chapter I.9. The UMAX VVM may be returned to service after appropriate restoration (reapplication of coatings etc.) if there is no significant increase in the measured dose rates (i.e., the shielding effectiveness of the overpack is confirmed) and if the visual inspection is satisfactory.

I.12.2.1.4 Conclusion

Based on the above evaluation, it is concluded that the Design Basis Fire accident does not affect the safety of stored fuel and the confinement boundary under HI-STORM UMAX storage or HI-TRAC VW transfer operations. Radiation dose remains below 10CFR72.106 requirements.

HOLTEC INTERNATIONAL COPYRIGHTED MATERIAL	
HI-2115090	Proposed Rev. 3.E
I.12-13	

I.12.2.2 Tornado (Load Case 02 in Section 2.4)

As justified in Subsection I.2.3.2 this accident is bounded by the evaluation in the main body of the UMAX FSAR.

I.12.2.3 Flood (Load Case 7 in Table 2.4.1)**I.12.2.3.1 Cause of Flood**

Many ISFSIs are located in flood plains susceptible to floods. Therefore, it is necessary for such ISFSIs to define a Design Basis Flood (DBF). The potential sources for the floodwater may be swelling rivers or streams from heavy rains or rapid melting of upstream snow, tsunamis, dam break, earthquake, hurricane, etc.

I.12.2.3.2 Analysis

Because of its underground construction, the HI-STORM UMAX is not subject to overturning action by moving floodwater. The permissible height of floodwater for storing an 24PT1-DSC is governed by the design basis flood defined in Table 2.4.1. If 24PT1-DSC is not able to meet qualification under external pressure from a site's Design Basis Flood event then it shall not be deployed in the HI-STORM UMAX system.

The following is an evaluation of effects on structural, thermal, criticality, confinement, and radiation protection performance on the HI-STORM UMAX system.

i. Structural

As justified in Subsection I.2.3.7 this accident is bounded by the evaluation in the main body of the UMAX FSAR.

ii. Thermal

The flooded HI-STORM UMAX ISFSI will reject heat to the floodwater. Because the heat transfer coefficient in water is considerably greater than that under the ventilation air, the temperature of the contents will be lowered. Furthermore, the heat dissipated from 24PT1-DSC tends to boil the flood water entering "UMAX" cavity and lower water level to restore sufficient air ventilation flow. Thus, the thermal effect of flood is actually salutary for the system's performance.

Partial blockage of the bottom cutout is evaluated in Section I.4.6.2. The maximum temperatures are confirmed to remain below the Supplement I.2 accident temperature limits. In the case when flood water/soil is just high enough to completely block the divider shell cutout, it is bounded by the 100% inlet duct blockage accident evaluated in in this section.

HOLTEC INTERNATIONAL COPYRIGHTED MATERIAL	
HI-2115090	Proposed Rev. 3.E
I.12-14	

iii. Shielding

There is no adverse effect on the function of shielding features of the system as a result of this accident event. The floodwater provides additional shielding that would further reduce radiation dose.

iv. Criticality

There is no adverse effect on the criticality control features of the stored 24PT1-DSC as a result of this accident event. The criticality analysis is unaffected because under the flood accident canister integrity is not challenged as supported by the structural evaluation above.

v. Confinement

As supported by structural evaluation above the canister integrity is not challenged by flood accident. Thus there is no risk to the confinement function of the 24PT1-DSC.

vi. Radiation Protection and Consequences

As there is no effect on shielding or confinement functions as discussed above, there is no radiological consequence (from effluents and direct radiation) as a result of this accident event. A minor increase to occupational exposures for the performance of corrective actions is expected.

I.12.2.3.3 Flood Accident Corrective Action

The configuration of the HI-STORM UMAX VVMs renders them suitable to withstand a flooding event. Indeed, introducing water in the CEC is an effective method to lower the 24PT1-DSC contents' temperature. However, accumulation of debris in the intake plenum or the storage cavities is undesirable as long-term corrosion risk. Thus corrective actions in a timely manner are necessary. Guidance on this matter is provided in the main body of the FSAR.

I.12.2.3.4 Conclusion

Based on the above evaluation, it is concluded that the flood accident does not affect the safe operation of the loaded HI-STORM UMAX VVMs.

I.12.2.4 Earthquake (Load Case 03 in Section I.2.3.3)

Safety under earthquake load is addressed in Subsection I.2.3.3 and structural evaluation Subsection I.3.4.4.

HOLTEC INTERNATIONAL COPYRIGHTED MATERIAL	
HI-2115090	Proposed Rev. 3.E
I.12-15	

I.12.2.5 100% Fuel Rod Rupture

This accident event postulates the non-mechanistic condition that all the fuel rods rupture and that the quantities of fission product gases and fill gas are released from the fuel rods into the 24PT1-DSC cavity consistent with NUREG 1536 [1.0.5].

I.12.2.5.1 Cause of 100% Fuel Rod Rupture

Through all credible accident conditions, the HI-STORM UMAX system maintains the spent nuclear fuel in an inert environment while maintaining the peak fuel cladding temperature below the required short-term temperature limits, thereby providing assurance of fuel cladding integrity. Therefore, there is no credible cause for 100% fuel rod rupture. This accident is postulated in NUREG-1536 to evaluate confinement barrier for the theoretical maximum pressure under *non-mechanistic* failure of 100% of the fuel rods.

I.12.2.5.2 Analysis

The following is an evaluation of effects on structural, thermal, criticality, confinement, and radiation protection performance on the HI-STORM UMAX storage system.

i. Structural

The principal effect of 100% rod rupture is an increase in the 24PT1-DSC internal pressure. The pressure increase evaluated under the thermal effects analysis below supports the conclusion that 24PT1-DSC pressure remains below NUHOMS FSAR Table 3.1-6 accident limit [I.1.2.1].

ii. Thermal

24PT1-DSC internal pressure under the 100% fuel rod rupture accident and design basis co-incident heat load is computed and tabulated in Table I.4.4.6. The tabulated results support the conclusion that 100% fuel rod rupture pressure remains below NUHOMS FSAR Table 3.1-6 accident limit [I.1.2.1].

v. Shielding

There is no adverse effect on function of the shielding features of the system as a result of this accident event.

vi. Criticality

There is no effect on the function of criticality control features of the 24PT1-DSC.

vii. Confinement

HOLTEC INTERNATIONAL COPYRIGHTED MATERIAL	
HI-2115090	Proposed Rev. 3.E
I.12-16	

As supported by structural evaluation above there is no effect on the confinement function of the 24PT1-DSC.

viii. Radiation Protection and Consequences

As supported by shielding and confinement evaluations above, there is no radiological consequence (from effluents and direct radiation) and no increase to occupational exposures as a result of this accident event.

Based on the above, it is concluded that the non-mechanistic 100% fuel rod rupture accident event does not affect the safe operation of the HI-STORM UMAX system.

I.12.2.5.3 100% Fuel Rod Rupture Dose Calculations

The breach of fuel cladding postulated in this accident event does not result in confinement breach or reduction in shielding function. Radiation dose at the site boundary is not affected.

I.12.2.5.4 100% Fuel Rod Rupture Accident Corrective Action

As evaluated above the HI-STORM UMAX storage System is designed to withstand this accident and continues to provide safe storage of spent nuclear fuel. No corrective actions are required.

I.12.2.5.5 Conclusion

The above evaluation shows that this accident event does not adversely affect the continued safety of the storage system.

I.12.2.6 Confinement Boundary Leakage

None of the design basis off-normal and accident conditions evaluated herein precipitate failure of the 24PT1-DSC confinement boundary. The analyses presented in the HI-STORM FW FSAR and in Supplement I.3 provide reasonable assurance that the 24PT1-DSC remains intact during all design basis accident conditions. The evaluation in Supplement I.7 concludes that confinement is maintained under all normal, off-normal and accident conditions. Confinement boundary leakage is non-credible.

I.12.2.7 Explosion (Load Case 01 in Section 2.4)

I.12.2.7.1 Cause of Explosion

An explosion within the protected area of an ISFSI is improbable since there are no explosive materials permitted within the site boundary. However, an explosion as a result of combustion of the fuel contained in a cask transport vehicle is possible. As the fuel available for the explosion is

HOLTEC INTERNATIONAL COPYRIGHTED MATERIAL	
HI-2115090	Proposed Rev. 3.E
I.12-17	

limited in quantity, the effects of an explosion on a reinforced structure are minimal. Explosions that are credible for a specific ISFSI would require a site hazards evaluation under the provisions of 10CFR72.212 regulations by the ISFSI owner using the methodology set forth in Chapter 3.

I.12.2.7.2 Explosion Analysis

As explosive materials are not stored within close proximity to the casks explosion near casks is not credible. For defense-in-depth an explosion load case is defined in Subsection I.2.3.1 and evaluated.

i. Structural

The structural adequacy of VVM and 24PT1-DSC is addressed in Supplement I.2. Site-specific explosion scenarios that are not evidently bounded by the design basis explosion load considered in this FSAR shall be evaluated under the provisions of 10CFR72.212.

ii. Thermal

There is no effect on the function of HI-STORM UMAX VVM heat transfer features as a result of this accident event occurring at the ISFSI. No deformation of the HI-STORM UMAX VVM components that would result in the constriction of the air flow passages within the VVM is indicated.

iii. Shielding

There is no effect on the function of shielding features of the system as a result of this accident event.

v. Criticality

There is no effect on the function of criticality control features of the 24PT1-DSC as a result of this accident event.

vi. Confinement

There is no effect on the confinement function of the 24PT1-DSC as a result of this accident event. As the above mentioned structural evaluation shows, all stresses remain within allowable values, assuring confinement boundary integrity.

vii. Radiation Protection and Consequences

Since there is no effect on shielding or confinement functions as discussed above, there is no radiological consequence (from effluents and direct radiation) as a result of this accident

HOLTEC INTERNATIONAL COPYRIGHTED MATERIAL	
HI-2115090	Proposed Rev. 3.E
I.12-18	

event. A negligible-to-minor increase to occupational exposures for the performance of corrective actions is expected.

I.12.2.7.3 Corrective Action

As there is no permanent damage indicated by this accident event, there is no need for a corrective action.

I.12.2.7.4 Conclusion

Based on the above evaluation, it is concluded that the design basis explosion accident event does not affect the safe operation of the loaded HI-STORM UMAX storage system.

I.12.2.8 100% Blockage of Air Inlet

I.12.2.8.1 Cause of 100% Blockage of Air Inlet

This event is defined as a complete blockage of all VVM inlets. A complete blockage of all VVM inlets cannot be realistically postulated to occur at many sites. However, a flood, blizzard snow accumulation, tornado debris, or volcanic activity, where applicable, can cause a significant blockage.

I.12.2.8.2 100% Blockage of Air Inlet Analysis

The immediate consequence of a complete blockage of the air inlet openings is that the normal circulation of air for cooling the 24PT1-DSC is stopped. An amount of heat will continue to be removed by localized air circulation patterns in the outlet opening, and the 24PT1-DSC will continue to radiate heat to the relatively cooler VVM. As the temperatures of the 24PT1-DSC and its contents rise, the rate of heat rejection will concomitantly increase. Under this condition, the temperatures of the 24PT1-DSC and the stored fuel assemblies will monotonically rise. This accident condition however is a short duration event that is identified and corrected by periodic surveillance or temperature monitoring as mandated by technical specifications.

i. Structural

The principal effect is a pressure rise in accordance with Ideal Gas Law co-incident with rising temperatures. This effect is evaluated under thermal effects evaluation below.

ii. Thermal

A thermal analysis is performed in Subsection I.4.6.2 to determine the effect of a complete blockage of all inlets. The principal objective of the analysis is to evaluate cladding and confinement integrity. The evaluation supports the conclusion that cladding temperature and confinement boundary pressure remain within Supplement I.2 accident limits.

HOLTEC INTERNATIONAL COPYRIGHTED MATERIAL	
HI-2115090	Proposed Rev. 3.E
I.12-19	

iii. Shielding

Shielding function is not affected by this accident.

iv. Criticality

There is no effect on the function of criticality control features of the 24PT1-DSC.

v. Confinement

The 24PT1-DSC confinement boundary is not challenged by this accident.

vi. Radiation Protection and Consequences

As supported by shielding and confinement evaluations above there is no radiological consequence (from effluents and direct radiation) as a result of this event.

I.12.2.8.3 Corrective Action

Analysis of the 100% blockage of air inlet accident shows that the temperatures for system components and fuel cladding remain within accident temperature limits if the blockage is cleared within the time period mandated for surveillance inspections. Upon detection of the complete blockage of the air inlet openings, the ISFSI owner shall activate its emergency response procedure to remove the blockage with mechanical and manual means as necessary. After clearing the VVM openings, the system shall be visually and radiologically inspected for any damage. If exit air temperature monitoring is performed in lieu of direct visual inspections, the difference between the ambient air temperature and the exit air temperature will be the basis for the assurance that the temperature limits are not exceeded.

For an accident event that completely blocks the inlet or outlet air openings for greater than the analyzed duration, a site-specific evaluation or analysis may be performed to evaluate adequate heat removal. Adequate heat removal is defined as the minimum rate of heat dissipation that ensures cladding temperatures limits are met and structural integrity of the 24PT1-DSC and VVM is not compromised. For those events where an evaluation or analysis is not performed or is not successful in showing that cladding temperatures remain below their short term temperature limits, the site's emergency plan shall include provisions to address removal of the material blocking the air inlet openings and to provide alternate means of cooling prior to exceeding the time when the fuel cladding temperature reaches its short-term temperature limit. Alternate means of cooling could include, for example, spraying water into the air outlet opening using pumps or fire-hoses or blowing air into the air outlet opening, to directly cool the 24PT1-DSC.

HOLTEC INTERNATIONAL COPYRIGHTED MATERIAL	
HI-2115090	Proposed Rev. 3.E
I.12-20	

I.12.2.8.4 Conclusion

Based on the above evaluation, it is concluded that the 100% blockage of air inlet accident event does not affect safe operation of the HI-STORM UMAX System, if blockage is removed within the time mandated by technical specifications.

I.12.2.9 Burial Under Debris**I.12.2.9.1 Cause of Burial Under Debris**

Complete burial of the entire HI-STORM UMAX VVM assembly is not a credible accident as there are no large structures above the casks that may collapse and bury the VVM. The minimum regulatory distance(s) from the ISFSI to the nearest site boundary and the controlled area around the ISFSI concrete pad precludes the close proximity of substantial amounts of vegetation. However, for purposes of safety evaluation, complete burial of the VVM including blockage of all inlet and outlet flow passages is postulated and evaluated.

I.12.2.9.2 Burial Under Debris Analysis

Burial of the inlet plenum under debris will adversely affect thermal performance because the debris will block the inflow of air. This will cause the fuel cladding temperatures to increase. A thermal analysis has been performed to determine the time for the fuel cladding temperatures to reach the *accident condition temperature limit*.

i. Structural

The effect of 100% blockage of air inlet on the 24PT1-DSC is an increase in component and fuel temperatures and co-incident pressures. These are evaluated under thermal effects evaluation below to remain below accident pressure limits.

ii. Thermal

The fuel cladding and 24PT1-DSC integrity is evaluated in Subsection I.4.6.2. The evaluation supports fuel cladding temperature and confinement boundary pressure limits compliance. Integrity of the stored fuel and 24PT1-DSC is not challenged by this accident.

iii. Shielding

Shielding function is not affected by this accident.

iv. Criticality

There is no effect on the criticality control function of the 24PT1-DSC.

HOLTEC INTERNATIONAL COPYRIGHTED MATERIAL	
HI-2115090	Proposed Rev. 3.E
I.12-21	

v. Confinement

As supported by structural evaluation above the confinement function of the 24PT1-DSC is not affected by this accident.

vi. Radiation Protection and Consequences

Since there is no effect on shielding or confinement functions as discussed above, there is no radiological consequence (from effluents and direct radiation) as a result of this event. A negligible-to-minor increase to occupational exposures for the performance of corrective actions is expected.

I.12.2.9.3 Corrective Action

Analysis of the burial-under-debris accident shows that cladding temperature limits are not exceeded. Upon detection of the burial- under-debris accident, the ISFSI operator shall assign personnel to remove the debris from around and inside the VVM cavity with mechanical and manual means as necessary. After removing the debris, the UMAX VVM must be inspected for damage. Removal of obstructions to the air flow path shall be performed prior to returning the UMAX for normal operation. At sites wherein burial is credibly postulated the site emergency plan shall as a minimum include provisions for the implementation of these corrective actions.

I.12.2.9.4 Conclusion

Based on the above evaluation, it is concluded that the burial-under-debris accident event does not affect safe operation of the HI-STORM UMAX System, if blockage is removed within analyzed time period as provided in the supplement or obtained via site specific evaluations.

I.12.2.10 Extreme Environmental Temperature

I.12.2.10.1 Cause of Extreme Environmental Temperature

The extreme environmental temperature is postulated as an elevated 3-day average temperature caused by extreme weather conditions.

I.12.2.10.2 Extreme Environmental Temperature Analysis

To determine the effects of the extreme temperature, it is conservatively assumed that the temperature persists for a sufficient duration to allow the HI-STORM storage system to reach thermal equilibrium.

HOLTEC INTERNATIONAL COPYRIGHTED MATERIAL	
HI-2115090	Proposed Rev. 3.E
I.12-22	

i. Structural

The effect on the 24PT1-DSC under the extreme environmental temperature is an increase in component and fuel cladding temperatures and co-incident internal pressure. As evaluated under thermal effects below the temperatures and pressures remain below Supplement I.2 accident limits.

ii. Thermal

Extreme environmental temperature is evaluated in Subsection I.4.2. The maximum calculated temperatures and 24PT1-DSC pressures are evaluated to remain below Supplement I.2 Table I.2.2.1 and NUHOMS FSAR Table 3.1-6 accident limits [I.1.2.1]. The evaluation supports the conclusion that safety of the stored fuel and canister confinement boundary is reasonably assured.

iii. Shielding

There is no effect on the shielding function of the VVM as concrete temperatures evaluated in the thermal analysis above remains below accident limits.

iv. Criticality

There is no effect on the criticality function of the 24PT1-DSC.

v. Confinement

As supported by structural evaluation above there is no effect on the confinement function of the 24PT1-DSC. as a result of this accident event.

vi. Radiation Protection and Consequences

As there is no effect on shielding and confinement functions, there is no radiological consequence (from effluents and direct radiation) and no increase to occupational or public exposures as a result of this accident event.

I.12.2.10.3 Corrective Action

No corrective action is required.

I.12.2.10.4 Conclusion

Based on this evaluation, it is concluded that the extreme environment temperature accident event does not affect the safe operation of the HI-STORM UMAX System.

HOLTEC INTERNATIONAL COPYRIGHTED MATERIAL	
HI-2115090	Proposed Rev. 3.E
I.12-23	

I.12.2.11 HI-TRAC VW Transfer Cask Handling Accident

HI-TRAC VW transfer cask handling accident is non-credible as it is handled by devices that prevent uncontrolled lowering. See main body of the UMAX FSAR, Section 12.2.

HOLTEC INTERNATIONAL COPYRIGHTED MATERIAL	
HI-2115090	Proposed Rev. 3.E
I.12-24	

I.12.3 OTHER EVENTS

This section addresses miscellaneous events, which are placed in the category of “other events” since they cannot be categorized as off-normal or accident events. The following “other events” are discussed in this chapter:

- Hazards during Construction Proximate to the ISFSI
- 24PT1-DSC Reflood

The results of the evaluations performed herein demonstrate that the loaded HI-STORM UMAX VVMs can withstand the effects of “other events” without affecting safety function.

I.12.3.1 Construction Proximate to an Operating ISFSI

The principal concern under this scenario is an earthquake event. As evaluated in Supplement I.2 the Maximum Site Earthquake (MSE) summarized below addresses this concern.

From the results of the SSI analysis discussed in Section I.3.4.4.1.2 and presented in Table I.3.4.3, it can be seen that all the results for the 24PT1-DSC that is stored inside HI-STORM UMAX under the MSE condition are bounded by those presented in Section 3.4.4.1.2. Also, the same Self-hardening Engineered Subgrade (SES) and ISFSI structures that were previously qualified in Chapter 3, will be used for the HI-STORM UMAX VVM array that is loaded with the 24 PT1-DSC hence the evaluation in the main body of the FSAR remains applicable to the HI-STORM UMAX under the MSE condition with the 24 PT1-DSC.

I.12.3.2 24PT1-DSC Reflood

Canister reflood is an operational step supporting fuel unloading at sites requiring access to fuel assemblies. This operation is supported by 24PT1-DSC reflood evaluated in the NUHOMS FSAR [I.1.2.1]. This evaluation is incorporated by reference in Table I.12.0.1.

HOLTEC INTERNATIONAL COPYRIGHTED MATERIAL	
HI-2115090	Proposed Rev. 3.E
I.12-25	

SUPPLEMENT I.13: OPERATING CONTROLS AND LIMITS¹

I.13.0 INTRODUCTION

This supplement defines the operating controls and limits (i.e., Technical Specifications) including their supporting bases for deployment and storage of the 24PT1-DSC in a HI-STORM UMAX VVM at an ISFSI. Operating controls and limits for other canisters analyzed for this FSAR are provided in Chapter 13 of the main body of this FSAR. The Certificate of Compliance sought pursuant to this supplement is limited to qualifying the 24PT1-DSC for storage in the HI-STORM UMAX.

¹ Supplement I adds the 24PT1-DSC canister to the HI-STORM UMAX system. Only those design features, analyses, evaluations and regulatory requirements of “UMAX” that are revised or added to incorporate the 24PT1-DSC canister are described in this chapter. This chapter also references to the main body of the FSAR where existing safety analyses or evaluations are bounding, as applicable.

HOLTEC INTERNATIONAL COPYRIGHTED MATERIAL	
HI-2115090	Proposed Rev. 3.E
I.13-1	

Table I.13.0.1: Material Incorporated by Reference from [I.1.2.1]

Information Incorporated by Reference	Source of the Information	NRC Approval of Material Incorporated by Reference	Location in this FSAR where Material is Incorporated	Technical Justification of Applicability to HI-STORM UMAX
Canister and Basket Structural Materials Properties	Sections 3.3.1 and 3.3.3 of Reference [I.1.2.1]	Standardized Advanced NUHOMS FSAR, Revision 6 [I.1.2.1]	I.13.2.8	Properties of the 24PT1-DSC and Basket materials are provided, analyzed and evaluated in the Standardized Advance NUHOMS FSAR. This supplement to the UMAX FSAR analyzes bounding cases via conservative properties/analyses.
Canister and Basket Thermal Materials Properties	Section 4.2 of Reference [I.1.2.1]			
Canister and Basket Shielding Materials Properties	Section 5.3.2 of Reference [I.1.2.1]			
Canister and Basket Shielding Materials Properties	Section 6.3.2 of Reference [I.1.2.1]			
QA Program for 24PT1-DSC canister	Section 13.1 of Reference [I.1.2-1]	Standardized Advanced NUHOMS FSAR, Revision 6 [I.1.2.1]	I.13.2.7	The canisters are designed and fabricated in accordance with the existing TN NRC approved QA program, which is unchanged by their storage in the HI-STORM UMAX System. The HI-STORM UMAX System and its ancillaries are designed, fabricated, and constructed under the Holtec NRC approved QA program.

HOLTEC INTERNATIONAL COPYRIGHTED MATERIAL	
HI-2115090	Proposed Rev. 3.E
I.13-2	

I.13.1 PROPOSED OPERATING CONTROLS AND LIMITS

I.13.1.1 NUREG-1536 (Standard Review Plan) Acceptance Criteria

This portion of the FSAR supplement establishes the commitments regarding usage of the HI-STORM UMAX system loaded with the 24PT1-DSC. In addition to the 10CFR72 [I.13.1.1] and 10CFR20 [I.13.1.2] requirements, users (general licensees) shall comply with the Technical Specifications prior to loading the 24PT1-DSC into the UMAX System in accordance with 10CFR 72.212 [I.13.1.1]. The general license conditions governed by 10CFR72 [I.13.1.1] are not repeated within these Technical Specifications. Licensees are required to comply with all commitments and requirements.

The Technical Specifications provided in Appendix C to the CoC and the authorized contents and design features provided in Appendix D to the CoC are primarily established to maintain subcriticality, the confinement boundary, shielding and radiological protection, heat removal capability, and structural integrity under normal, off-normal and accident conditions.

Table I.13.1.1 addresses conditions applicable to storage of the 24PT1-DSC in the HI-STORM UMAX and identifies the appropriate Technical Specification(s) designed to control the condition. Table I.13.1.2 provides the list of Technical Specifications for the loading operations and long term fuel storage in the HI-STORM UMAX system.

HOLTEC INTERNATIONAL COPYRIGHTED MATERIAL	
HI-2115090	Proposed Rev. 3.E
I.13-3	

Table I.13.1.1	
HI-STORM UMAX SYSTEM CONTROLS (24PT1-DSC)	
Condition to be Controlled	Applicable Technical Specifications [†]
Shielding and radiological protection	5.1 Radioactive Effluent Control Program 5.3 Radiation Protection Program
Heat removal capability	3.1.1 SFSC Heat Removal System
Structural integrity	5.2 Transport Evaluation Program

[†] Technical Specifications are located in Appendix A to the CoC. Authorized contents are specified in this FSAR in Subsection 2.1.8

HOLTEC INTERNATIONAL COPYRIGHTED MATERIAL	
HI-2115090	Proposed Rev. 3.E
I.13-4	

Table I.13.1.2	
HI-STORM UMAX SYSTEM TECHNICAL SPECIFICATIONS (24PT1-DSC)	
NUMBER	TECHNICAL SPECIFICATION
1.0	USE AND APPLICATION
1.1	DEFINITIONS
1.2	LOGICAL CONNECTORS
1.3	COMPLETION TIMES
1.4	FREQUENCY
2.0	Not Used
3.0	LIMITING CONDITION FOR OPERATION (LCO) APPLICABILITY SURVEILLANCE REQUIREMENT (SR) APPLICABILITY
3.1	SFSC Integrity
3.1.1	SFSC Heat Removal System
4.0	Not Used
5.0	ADMINISTRATIVE CONTROLS
5.1	Radioactive Effluent Control Program
5.2	Transport Evaluation Program
5.3	Radiation Protection Program

HOLTEC INTERNATIONAL COPYRIGHTED MATERIAL	
HI-2115090	Proposed Rev. 3.E
I.13-5	

I.13.2 DEVELOPMENT OF OPERATING CONTROLS AND LIMITS

This section provides a discussion of the operating controls and limits, and training requirements for the HI-STORM UMAX system to assure long-term performance consistent with the conditions analyzed in this supplement.

I.13.2.1 Training Modules

Training modules are to be developed under the licensee's training program for loading of the 24PT1-DSC into the HI-STORM UMAX, and unloading of the canister from the HI-STORM UMAX, and shall include site-specific training, assessment, and qualification (including periodic re-qualification) program for the operation and maintenance of the HI-STORM UMAX Spent Fuel Storage Cask (SFSC) System and the Independent Spent Fuel Storage Installation (ISFSI). The training module shall include the elements provided in Subsection 13.2.1 of the main body of the FSAR, appropriately adopted for storage of the 24PT1-DSC. Training on equipment specific to storage of the 24PT1-DSC, such as the CHA and TSRA shall also be included.

I.13.2.2 Dry Run Training

A dry run training exercise of the handling, unloading and transfer of the HI-STORM UMAX system during 24PT1-DSC storage operations shall be conducted by the licensee prior to the first use of the system. The dry run shall include the elements in Subsection 13.2.2 of the main body of this FSAR, except that the canister to be loaded for storage is the 24PT1-DSC and fuel loading/unloading operations are not included in storage operations for the 24PT1-DSC in the UMAX System.

I.13.2.3 Functional and Operating Limits, Monitoring Instruments, and Limiting Control Settings

The controls and limits apply to operating parameters and conditions which are observable, detectable, and/or measurable. The HI-STORM UMAX system is completely passive during storage and requires no monitoring instruments. The user may choose to implement a temperature monitoring system or visually inspect the vent screens to verify operability of the VVM heat removal system in accordance with Technical Specification Limiting Condition for Operation (LCO) 3.1.2.

I.13.2.4 Limiting Conditions for Operation (LCO)

Limiting Conditions for Operation (LCO) specify the minimum capability or level of performance that is required to assure that the HI-STORM UMAX system can fulfill its safety functions.

HOLTEC INTERNATIONAL COPYRIGHTED MATERIAL	
HI-2115090	Proposed Rev. 3.E
I.13-6	

I.13.2.5 Equipment

The HI-STORM UMAX system and its components have been analyzed for specified normal, off-normal, and accident conditions, including extreme environmental conditions. Analysis has shown that no credible condition or event prevents the HI-STORM UMAX system from meeting its safety function. As a result, there is no threat to public health and safety from any postulated accident condition or analyzed event. When all equipment is loaded, tested, and placed into storage in accordance with procedures developed for the ISFSI, no failure of the system to perform its safety function is expected to occur.

I.13.2.6 Surveillance Requirements

The analyses show that the HI-STORM UMAX system fulfills its safety functions, provided that the Technical Specifications and the Authorized Contents described in Subsection I.2.1.8 are met. Surveillance requirements during loading, unloading, and storage operations are provided in the Technical Specifications.

I.13.2.7 Design Features

This subsection describes HI-STORM UMAX system design features that are Important to Safety. These features require design controls and fabrication controls. The design features, detailed in this supplement and in Appendix D to the CoC, are established in specifications and drawings which are controlled through the quality assurance program of the system subcomponent manufacturer. Fabrication controls and inspections are in place to ensure that the HI-STORM UMAX system (excluding the 24PT1-DSC) is fabricated in accordance with the licensing drawings in Section I.1.5. Fabrication controls and inspection for fabrication of the 24PT1-DSC are in accordance with manufacturer's NRC approved quality assurance program in Section 13.1 of the Standardized Advanced NUHOMS System FSAR [I.1.2.1], and the licensing drawings and acceptance tests in Sections 1.5.2 and 9.1 of the Standardized Advance NUHOMS System FSAR, respectively.

I.13.2.7.1 24PT1-DSC

DSC and basket materials properties for criticality, heat transfer (thermal), shielding and structural evaluations are provided in the respective chapters of the Standardized Advance NUHOMS System FSAR [I.1.2.1]. See Table I.13.0.1 for specific referenced sections of the NUHOMS FSAR.

I.13.2.7.2 HI-STORM UMAX VVM

Provided in Subsection 13.2.9 of the main body of this FSAR.

HOLTEC INTERNATIONAL COPYRIGHTED MATERIAL	
HI-2115090	Proposed Rev. 3.E
I.13-7	

I.13.2.7.3 HI-TRAC Transfer Cask

Provided in Subsection 13.2.10 of the main body of this FSAR.

I.13.2.7.4 Canister Handling Apparatus (CHA)

- a. CHA material mechanical properties and dimensions for structural integrity to provide protection of the canister during handling and transfer operations.
- b. CHA material thermal properties and dimensions for heat transfer control.

I.13.2.7.5 Top Seismic Restraint Assembly (TSRA)

- a. HI-STORM UMAX VVM material mechanical properties and dimensions for structural integrity to provide stability and protection for the canister during storage and seismic events.
- b. HI-STORM UMAX VVM material thermal properties and dimensions for heat transfer control.

HOLTEC INTERNATIONAL COPYRIGHTED MATERIAL	
HI-2115090	Proposed Rev. 3.E
I.13-8	

I.13.3 TECHNICAL SPECIFICATIONS

Technical Specifications for the HI-STORM UMAX system are provided in Appendix C to the Certificate of Compliance. Authorized Contents (i.e., fuel specifications) and Design Features are provided in Appendix D to the CoC. Bases applicable to the Technical Specifications are provided in Appendix I.13.A to this supplement. The format and content of the HI-STORM UMAX system Technical Specifications and Bases are that of the Improved Standard Technical Specifications for power reactors, to the extent they apply to a dry spent fuel storage cask system. NUMARC Document 93-03, “Writer’s Guide for the Restructured Technical Specifications” [I.13.3.1] was used as a guide in the development of the Technical Specifications and Bases.

HOLTEC INTERNATIONAL COPYRIGHTED MATERIAL	
HI-2115090	Proposed Rev. 3.E
I.13-9	

I.13.4 REGULATORY EVALUATION

Table I.13.1.2 lists the Technical Specifications for the HI-STORM UMAX system. The Technical Specifications are detailed in Appendix C to the Certificate of Compliance. Authorized Contents (i.e., fuel specifications) and Design Features are provided in Appendix D to the CoC.

The conditions for use of the HI-STORM UMAX system when loaded with a 24PT1-DSC, identify necessary Technical Specifications, limits on authorized contents (i.e., fuel), and design features to satisfy 10 CFR Part 72, and the applicable acceptance criteria have been satisfied. Compliance with these Technical Specifications and other conditions of the Certificate of Compliance provides reasonable assurance that the HI-STORM UMAX system will provide safe storage of spent fuel and is in compliance with 10 CFR Part 72, the regulatory guides, applicable codes and standards, and accepted practices.

HOLTEC INTERNATIONAL COPYRIGHTED MATERIAL	
HI-2115090	Proposed Rev. 3.E
I.13-10	

I.13.5 REFERENCES

- [I.13.1.1] U.S. Code of Federal Regulations, “Licensing Requirements for Independent Storage of Spent Nuclear Fuel, High-Level Radioactive Waste, and Reactor-Related Greater Than Class C Waste,” Part 72, Chapter I, Title 10, “Energy.”
- [I.13.1.2] U.S. Code of Federal Regulations, “Standards for Protection Against Radiation,” Part 20, Chapter I, Title 10, “Energy.”
- [I.13.3.1] Nuclear Management and Resources Council, Inc. “Writer’s Guide for the Restructured Technical Specifications”, NUMARC 93-03, February 1993.

HOLTEC INTERNATIONAL COPYRIGHTED MATERIAL	
HI-2115090	Proposed Rev. 3.E
I.13-11	

HI-STORM UMAX SYSTEM FSAR

APPENDIX I.13.A

TECHNICAL SPECIFICATION BASES

FOR THE HOLTEC HI-STORM UMAX CANISTER STORAGE SYSTEM

HOLTEC INTERNATIONAL COPYRIGHTED MATERIAL		
HI-STORM UMAX Supplement I Rev 3I HI 2115090 April 2020	264 of 282	Proposed Rev. 3.E
I.13.A-1		

BASES TABLE OF CONTENTS

B 3.0 LIMITING CONDITION FOR OPERATION (LCO) APPLICABILITYI.13.A-3
B 3.0 SURVEILLANCE REQUIREMENT (SR) APPLICABILITY.....I.13.A-6

B 3.1 SFSC INTEGRITYI.13.A-12
B 3.1.1 SFSC Heat Removal System.....I.13.A-12

B 3.0 LIMITING CONDITION FOR OPERATION (LCO) APPLICABILITY**BASES**

LCOs	LCO 3.0.1, 3.0.2, 3.0.4, and 3.0.5 establish the general requirements applicable to all Specifications and apply at all times, unless otherwise stated.
LCO 3.0.1	LCO 3.0.1 establishes the Applicability statement within each individual Specification as the requirement for when the LCO is required to be met (i.e., when the facility is in the specified conditions of the Applicability statement of each Specification).
LCO 3.0.2	LCO 3.0.2 establishes that upon discovery of a failure to meet an LCO, the associated ACTIONS shall be met. The Completion Time of each Required Action for an ACTIONS Condition is applicable from the point in time that an ACTIONS Condition is entered. The Required Actions establish those remedial measures that must be taken within specified Completion Times when the requirements of an LCO are not met. This Specification establishes that: <ul style="list-style-type: none"> a. Completion of the Required Actions within the specified Completion Times constitutes compliance with a Specification; and b. Completion of the Required Actions is not required when an LCO is met within the specified Completion Time, unless otherwise specified.

There are two basic types of Required Actions. The first type of Required Action specifies a time limit in which the LCO must be met. This time limit is the Completion Time to restore a system or component or to restore variables to within specified limits. Whether stated as a Required Action or not, correction of the entered Condition is an action that may always be considered upon entering ACTIONS. The second type of Required Action specifies the remedial measures that permit continued operation that is not further restricted by the Completion Time. In this case, compliance with the Required Actions provides an acceptable level of safety for continued operation.

(continued)

HOLTEC INTERNATIONAL COPYRIGHTED MATERIAL	
HI-2115090	Proposed Rev. 3.E
I.13.A-3	

BASES

LCO 3.0.2 (continued) Completing the Required Actions is not required when an LCO is met or is no longer applicable, unless otherwise stated in the individual Specifications.

The Completion Times of the Required Actions are also applicable when a system or component is removed from service intentionally. The reasons for intentionally relying on the ACTIONS include, but are not limited to, performance of Surveillances, preventive maintenance, corrective maintenance, or investigation of operational problems. Entering ACTIONS for these reasons must be done in a manner that does not compromise safety. Intentional entry into ACTIONS should not be made for operational convenience.

LCO 3.0.3 This specification is not applicable to a dry storage cask system because it describes conditions under which a power reactor must be shut down when an LCO is not met and an associated ACTION is not met or provided. The placeholder is retained for consistency with the power reactor technical specifications.

LCO 3.0.4 LCO 3.0.4 establishes limitations on changes in specified conditions in the Applicability when an LCO is not met. It precludes placing the HI-STORM UMAX System in a specified condition stated in that Applicability (e.g., Applicability desired to be entered) when the following exist:

- a. Facility conditions are such that the requirements of the LCO would not be met in the Applicability desired to be entered; and
- b. Continued noncompliance with the LCO requirements, if the Applicability were entered, would result in being required to exit the Applicability desired to be entered to comply with the Required Actions.

Compliance with Required Actions that permit continuing with dry fuel storage activities for an unlimited period of time in a specified condition provides an acceptable level of safety for continued operation. This is without regard to the status of the dry storage system. Therefore, in such cases, entry into a specified condition in the Applicability may be made in accordance with the provisions of the Required Actions. The provisions of this Specification should not be interpreted as endorsing the failure to exercise the good practice of restoring systems or components before entering an associated specified condition in the Applicability.

(continued)

HOLTEC INTERNATIONAL COPYRIGHTED MATERIAL	
HI-2115090	Proposed Rev. 3.E
I.13.A-4	

BASES

LCO 3.0.4 (continued) The provisions of LCO 3.0.4 shall not prevent changes in specified conditions in the Applicability that are required to comply with ACTIONS. In addition, the provisions of LCO 3.0.4 shall not prevent changes in specified conditions in the Applicability that are related to the unloading of an SFSC.

Exceptions to LCO 3.0.4 are stated in the individual Specifications. Exceptions may apply to all the ACTIONS or to a specific Required Action of a Specification.

LCO 3.0.5 LCO 3.0.5 establishes the allowance for restoring equipment to service under administrative controls when it has been removed from service or determined to not meet the LCO to comply with the ACTIONS. The sole purpose of this Specification is to provide an exception to LCO 3.0.2 (e.g., to not comply with the applicable Required Action(s)) to allow the performance of testing to demonstrate:

- a. The equipment being returned to service meets the LCO; or
- b. Other equipment meets the applicable LCOs.

The administrative controls ensure the time the equipment is returned to service in conflict with the requirements of the ACTIONS is limited to the time absolutely necessary to perform the allowed testing. This Specification does not provide time to perform any other preventive or corrective maintenance.

HOLTEC INTERNATIONAL COPYRIGHTED MATERIAL	
HI-2115090	Proposed Rev. 3.E
I.13.A-5	

B 3.0 SURVEILLANCE REQUIREMENT (SR) APPLICABILITY**BASES**

SRs	SR 3.0.1 through SR 3.0.4 establish the general requirements applicable to all Specifications and apply at all times, unless otherwise stated.
-----	--

HOLTEC INTERNATIONAL COPYRIGHTED MATERIAL	
HI-2115090	Proposed Rev. 3.E
I.13.A-6	

BASES

SR 3.0.1 SR 3.0.1 establishes the requirement that SRs must be met during the specified conditions in the Applicability for which the requirements of the LCO apply, unless otherwise specified in the individual SRs. This Specification is to ensure that Surveillances are performed to verify that systems and components meet the LCO and variables are within specified limits. Failure to meet a Surveillance within the specified Frequency, in accordance with SR 3.0.2, constitutes a failure to meet an LCO.

Systems and components are assumed to meet the LCO when the associated SRs have been met. Nothing in this Specification, however, is to be construed as implying that systems or components meet the associated LCO when:

- a. The systems or components are known to not meet the LCO, although still meeting the SRs; or
- b. The requirements of the Surveillance(s) are known to be not met between required Surveillance performances.

Surveillances do not have to be performed when the HI-STORM UMAX System is in a specified condition for which the requirements of the associated LCO are not applicable, unless otherwise specified.

Surveillances, including Surveillances invoked by Required Actions, do not have to be performed on equipment that has been determined to not meet the LCO because the ACTIONS define the remedial measures that apply. Surveillances have to be met and performed in accordance with SR 3.0.2, prior to returning equipment to service. Upon completion of maintenance, appropriate post-maintenance testing is required. This includes ensuring applicable Surveillances are not failed and their most recent performance is in accordance with SR 3.0.2. Post maintenance testing may not be possible in the current specified conditions in the Applicability due to the necessary dry storage cask system parameters not having been established. In these situations, the equipment may be considered to meet the LCO provided testing has been satisfactorily completed to the extent possible and the equipment is not otherwise believed to be incapable of performing its function. This will allow dry fuel storage activities to proceed to a specified condition where other necessary post maintenance tests can be completed.

(continued)

HOLTEC INTERNATIONAL COPYRIGHTED MATERIAL	
HI-2115090	Proposed Rev. 3.E
I.13.A-7	

BASES

SR 3.0.2 SR 3.0.2 establishes the requirements for meeting the specified Frequency for Surveillances and any Required Action with a Completion Time that requires the periodic performance of the Required Action on a "once per..." interval.

SR 3.0.2 permits a 25% extension of the interval specified in the Frequency. This extension facilitates Surveillance scheduling and considers facility conditions that may not be suitable for conducting the Surveillance (e.g., transient conditions or other ongoing Surveillance or maintenance activities).

The 25% extension does not significantly degrade the reliability that results from performing the Surveillance at its specified Frequency. This is based on the recognition that the most probable result of any particular Surveillance being performed is the verification of conformance with the SRs. The exceptions to SR 3.0.2 are those Surveillances for which the 25% extension of the interval specified in the Frequency does not apply. These exceptions are stated in the individual Specifications as a Note in the Frequency stating, "SR 3.0.2 is not applicable."

As stated in SR 3.0.2, the 25% extension also does not apply to the initial portion of a periodic Completion Time that requires performance on a "once per..." basis. The 25% extension applies to each performance after the initial performance. The initial performance of the Required Action, whether it is a particular Surveillance or some other remedial action, is considered a single action with a single Completion Time. One reason for not allowing the 25% extension to this Completion Time is that such an action usually verifies that no loss of function has occurred by checking the status of redundant or diverse components or accomplishes the function of the affected equipment in an alternative manner. The provisions of SR 3.0.2 are not intended to be used repeatedly merely as an operational convenience to extend Surveillance intervals or periodic Completion Time intervals beyond those specified.

(continued)

HOLTEC INTERNATIONAL COPYRIGHTED MATERIAL	
HI-2115090	Proposed Rev. 3.E
I.13.A-8	

BASES

SR 3.0.3 SR 3.0.3 establishes the flexibility to defer declaring affected equipment as not meeting the LCO or an affected variable outside the specified limits when a Surveillance has not been completed within the specified Frequency. A delay period of up to 24 hours or up to the limit of the specified Frequency, whichever is less, applies from the point in time that it is discovered that the Surveillance has not been performed in accordance with SR 3.0.2, and not at the time that the specified Frequency was not met.

This delay period provides adequate time to complete Surveillances that have been missed. This delay period permits the completion of a Surveillance before complying with Required Actions or other remedial measures that might preclude completion of the Surveillance.

The basis for this delay period includes consideration of HI-STORM UMAX System conditions, adequate planning, availability of personnel, the time required to perform the Surveillance, the safety significance of the delay in completing the required Surveillance, and the recognition that the most probable result of any particular Surveillance being performed is the verification of conformance with the requirements. When a Surveillance with a Frequency based not on time intervals, but upon specified facility conditions, is discovered not to have been performed when specified, SR 3.0.3 allows the full delay period of 24 hours to perform the Surveillance.

SR 3.0.3 also provides a time limit for completion of Surveillances that become applicable as a consequence of changes in the specified conditions in the Applicability imposed by the Required Actions.

Failure to comply with specified Frequencies for SRs is expected to be an infrequent occurrence. Use of the delay period established by SR 3.0.3 is a flexibility which is not intended to be used as an operational convenience to extend Surveillance intervals.

(continued)

HOLTEC INTERNATIONAL COPYRIGHTED MATERIAL	
HI-2115090	Proposed Rev. 3.E
I.13.A-9	

BASES

SR 3.0.3 (continued) If a Surveillance is not completed within the allowed delay period, then the equipment is considered to not meet the LCO or the variable is considered outside the specified limits and the Completion Times of the Required Actions for the applicable LCO Conditions begin immediately upon expiration of the delay period. If a Surveillance is failed within the delay period, then the equipment does not meet the LCO, or the variable is outside the specified limits and the Completion Times of the Required Actions for the applicable LCO Conditions begin immediately upon the failure of the Surveillance.

Completion of the Surveillance within the delay period allowed by this Specification, or within the Completion Time of the ACTIONS, restores compliance with SR 3.0.1.

SR 3.0.4 SR 3.0.4 establishes the requirement that all applicable SRs must be met before entry into a specified condition in the Applicability.

This Specification ensures that system and component requirements and variable limits are met before entry into specified conditions in the Applicability for which these systems and components ensure safe conduct of dry fuel storage activities.

The provisions of this Specification should not be interpreted as endorsing the failure to exercise the good practice of restoring systems or components before entering an associated specified condition in the Applicability.

However, in certain circumstances, failing to meet an SR will not result in SR 3.0.4 restricting a change in specified condition. When a system, subsystem, division, component, device, or variable is outside its specified limits, the associated SR(s) are not required to be performed per SR 3.0.1, which states that Surveillances do not have to be performed on equipment that has been determined to not meet the LCO. When equipment does not meet the LCO, SR 3.0.4 does not apply to the associated SR(s) since the requirement for the SR(s) to be performed is removed. Therefore, failing to perform the Surveillance(s) within the specified Frequency does not result in an SR 3.0.4 restriction to changing specified conditions of the Applicability. However, since the LCO is not met in this instance, LCO 3.0.4 will govern any restrictions that may (or may not) apply to specified condition changes.

(continued)

HOLTEC INTERNATIONAL COPYRIGHTED MATERIAL	
HI-2115090	Proposed Rev. 3.E
I.13.A-10	

BASES

SR 3.0.4 (continued) The provisions of SR 3.0.4 shall not prevent changes in specified conditions in the Applicability that are required to comply with ACTIONS. In addition, the provisions of LCO 3.0.4 shall not prevent changes in specified conditions in the Applicability that are related to the unloading of an SFSC.

The precise requirements for performance of SRs are specified such that exceptions to SR 3.0.4 are not necessary. The specific time frames and conditions necessary for meeting the SRs are specified in the Frequency, in the Surveillance, or both. This allows performance of Surveillances when the prerequisite condition(s) specified in a Surveillance procedure require entry into the specified condition in the Applicability of the associated LCO prior to the performance or completion of a Surveillance. A Surveillance that could not be performed until after entering the LCO Applicability would have its Frequency specified such that it is not "due" until the specific conditions needed are met. Alternately, the Surveillance may be stated in the form of a Note as not required (to be met or performed) until a particular event, condition, or time has been reached. Further discussion of the specific formats of SRs' annotation is found in Section 1.4, Frequency.

HOLTEC INTERNATIONAL COPYRIGHTED MATERIAL	
HI-2115090	Proposed Rev. 3.E
I.13.A-11	

B 3.1 SFSC Integrity

B 3.1.1 SFSC Heat Removal System

BASES

BACKGROUND The SFSC Heat Removal System is a passive, air-cooled, convective heat transfer system that ensures heat from the DSC is transferred to the environs by the chimney effect. Air is drawn into the inlet ducts and travels down the space between the Cavity Enclosure Container (CEC) and the Divider Shell, through the cut-outs at the bottom of the Divider Shell, up the space between the Divider Shell and the DSC, and out through the outlet duct. The DSC transfers its heat from its surface to the air via natural convection. The buoyancy created by the heating of the air creates a chimney effect.

APPLICABLE SAFETY ANALYSIS The thermal analyses of the SFSC take credit for the decay heat from the spent fuel assemblies being ultimately transferred to the ambient environment surrounding the VVM. Transfer of heat away from the fuel assemblies ensures that the fuel cladding and other SFSC component temperatures do not exceed applicable limits. Under normal storage conditions, the inlet and outlet duct screens are unobstructed and full air flow occurs.

Analyses have been performed for half and complete obstruction of the inlet duct screens. Blockage of half of the inlet ducts reduces air flow through the VVM and decreases heat transfer from the DSC. Under this off-normal condition, no SFSC components exceed the short term temperature limits.

The complete blockage of all inlet air ducts stops normal air cooling of the DSC. The DSC will continue to radiate heat to the relatively cooler subgrade. With the loss of normal air cooling, the SFSC component temperatures will increase toward their respective short-term temperature limits. None of the components reach their temperature limits over the duration of the analyzed event.

(continued)

HOLTEC INTERNATIONAL COPYRIGHTED MATERIAL	
HI-2115090	Proposed Rev. 3.E
I.13.A-12	

BASES	
LCO	<p>The SFSC Heat Removal System must be verified to be operable to preserve the assumptions of the thermal analyses. Operability is defined as 50% or less of the inlet air ducts are obstructed. Operability of the heat removal system ensures that the decay heat generated by the stored fuel assemblies is transferred to the environs at a sufficient rate to maintain fuel cladding and other SFSC component temperatures within design limits.</p> <p>The intent of this LCO is to address those occurrences of air duct screen blockage that can be reasonably anticipated to occur from time to time at the ISFSI (i.e., Design Event I and II class events per ANSI/ANS-57.9). These events are of the type where corrective actions can usually be accomplished within one 8-hour operating shift to restore the heat removal system to operable status (e.g., removal of loose debris).</p> <p>This LCO is not intended to address low frequency, unexpected Design Event III and IV class events (ANSI/ANS-57.9) such as design basis accidents and extreme environmental phenomena that could potentially block one or more of the air ducts for an extended period of time (i.e., longer than the total Completion Time of the LCO). This class of events is addressed site-specifically as required by Section 3.4.12 of Appendix D to the CoC.</p>
APPLICABILITY	<p>The LCO is applicable during STORAGE OPERATIONS. Once a DSC loaded with spent fuel has been placed in a storage VVM, the heat removal system must be operable to ensure adequate dissipation of the decay heat from the fuel assemblies.</p>
ACTIONS	<p>A note has been added to the ACTIONS which states that, for this LCO, separate Condition entry is allowed for each SFSC. This is acceptable since the Required Actions for each Condition provide appropriate compensatory measures for each SFSC not meeting the LCO. Subsequent SFSCs that don't meet the LCO are governed by subsequent Condition entry and application of associated Required Actions.</p> <p>(continued)</p>

HOLTEC INTERNATIONAL COPYRIGHTED MATERIAL	
HI-2115090	Proposed Rev. 3.E
I.13.A-13	

BASES

ACTIONS
(continued)**A.1**

Although the heat removal system remains operable, the blockage should be cleared expeditiously.

B.1

If the heat removal system has been determined to be inoperable, it must be restored to operable status within eight hours. Eight hours is a reasonable period of time to take action to remove the obstructions in the air flow path.

C.1

If the heat removal system cannot be restored to operable status within eight hours, the VVM and the fuel may experience elevated temperatures. Therefore, dose rates are required to be measured to verify the effectiveness of the radiation shielding provided by the concrete. This Action must be performed immediately and repeated every twelve hours thereafter to provide timely and continued evaluation of the effectiveness of the concrete shielding. As necessary, the system user shall provide additional radiation protection measures such as temporary shielding. The Completion Time is reasonable considering the expected slow rate of deterioration, if any, of the concrete under elevated temperatures.

C.2.1

In addition to Required Action C.1, efforts must continue to restore cooling to the SFSC. Efforts must continue to restore the heat removal system to operable status by removing the air flow obstruction(s) unless optional Required Action C.2.2 is being implemented.

This Required Action must be complete in 64 hours. The Completion Time is consistent with the thermal analyses of this event, which show that all component temperatures remain below their short-term temperature limits up to 72 hours after event initiation.

(continued)

HOLTEC INTERNATIONAL COPYRIGHTED MATERIAL	
HI-2115090	Proposed Rev. 3.E
I.13.A-14	

BASES

ACTIONS
(continued)

C.2.1 (continued)

The Completion Time reflects the 8 hours to complete Required Action B.1 and the appropriate balance of time consistent with the applicable analysis results. The event is assumed to begin at the time the SFSC heat removal system is declared inoperable. This is reasonable considering the low probability of all inlet ducts becoming simultaneously blocked.

C.2.2

In lieu of implementing Required Action C.2.1, transfer of the DSC into a TRANSFER CASK will place the DSC in an analyzed condition and ensure adequate fuel cooling until actions to correct the heat removal system inoperability can be completed. Transfer of the DSC into a TRANSFER CASK removes the SFSC from the LCO Applicability since STORAGE OPERATIONS does not include times when the DSC resides in the TRANSFER CASK.

An engineering evaluation must be performed to determine if any deterioration which prevents the VVM from performing its design function. If the evaluation is successful and the air inlet duct screens have been cleared, the VVM heat removal system may be considered operable and the DSC transferred back into the VVM. Compliance with LCO 3.1.2 is then restored. If the evaluation is unsuccessful, the user must transfer the DSC into a different, fully qualified VVM to resume STORAGE OPERATIONS and restore compliance with LCO 3.1.2

In lieu of performing the engineering evaluation, the user may opt to proceed directly to transferring the DSC into a different, fully qualified VVM or place the TRANSFER CASK in the spent fuel pool and unload the DSC.

The Completion Time of 64 hours reflects the Completion Time from Required Action C.2.1 to ensure component temperatures remain below their short-term temperature limits for the respective decay heat loads.

(continued)

HOLTEC INTERNATIONAL COPYRIGHTED MATERIAL	
HI-2115090	Proposed Rev. 3.E
I.13.A-15	

BASES

**SURVEILLANCE
REQUIREMENTS** **SR 3.1.2**

The long-term integrity of the stored fuel is dependent on the ability of the SFSC to reject heat from the DSC to the environment. There are two options for implementing SR 3.1.2, either of which is acceptable for demonstrating that the heat removal system is OPERABLE.

Visual observation that all air inlet duct screens are unobstructed ensures that the SFSC is operable. If greater than 50% of the air inlet duct screens are blocked the heat removal system is inoperable and this LCO is not met. While 50% or less blockage of the total air inlet duct screen area does not constitute inoperability of the heat removal system, corrective actions should be taken promptly to remove the obstruction and restore full flow.

As an alternative, for VVMs with air temperature monitoring instrumentation installed in the air outlets, the temperature difference between the outlet air and the ambient air may be monitored to verify operability of the heat removal system. Blocked air inlet duct screens will reduce air flow and increase the outlet duct air temperature. Based on the analyses, if the temperature difference between the ambient air and the outlet duct air meets the criteria in the LCO, adequate air flow is occurring to provide assurance of long term fuel cladding integrity. The reference ambient temperature used to perform this Surveillance shall be measured at the ISFSI facility.

The Frequency of 24 hours is reasonable based on the time necessary for SFSC components to heat up to unacceptable temperatures assuming design basis heat loads, and allowing for corrective actions to take place upon discovery of blockage of air ducts.

REFERENCES	1.	Supplement I.4
	2.	ANSI/ANS 57.9-1992

HOLTEC INTERNATIONAL COPYRIGHTED MATERIAL	
HI-2115090	Proposed Rev. 3.E
I.13.A-16	

SUPPLEMENT I.14[†]: QUALITY ASSURANCE PROGRAM

I.14.0 INTRODUCTION

I.14.0.1 Overview

This supplement provides a summary of the quality assurance program implemented by Holtec International for activities related to the design, qualification analyses, material procurement, fabrication, assembly, testing and use of structures, systems, and components of the Company's dry storage/transport systems including the HI-STORM UMAX System which includes the HI-TRAC transfer cask. This chapter is included in this FSAR to fulfill the requirements in 10 CFR 72.140 (c) (2) and 72.2(a)(1),(b).

Supplement I adds the 24PT1-DSC canister to the HI-STORM UMAX system [I.1.2.1]. Only those design features of "UMAX" that are revised or added to incorporate the 24PT1-DSC canister are described in this supplement. This supplement also references to the main body of the FSAR where existing safety analyses are bounding, as applicable.

Since the 24PT1-DSC canister has already been approved by the NRC for storage under Part 72, (and is presently in active use) under Docket No. 72-1029, much of the safety analysis information is incorporated herein by reference to the NUHOMS FSAR [I.1.2.1]. For clarity, a table in the beginning of each supplement (Table I.14.0.1 below) identifies the information incorporated by reference, the source of the information, a reference to the NRC approval of the information (SER), where in this supplement it is incorporated, and a discussion of the applicability of the previously approved information.

The material in this supplement is organized to mirror the corresponding material in the main body of the FSAR with the letter "I" inserted before each chapter/section/subsection/paragraph number. Thus the numeric sequence I.m.n.p.r indicates that the material belongs to Supplement I, Chapter #m, Section #n, sub-section# p and paragraph # r. (m, n, p and r are numeric values). Thus, the numbering of the material in the supplement is readily distinguished from the main FSAR's while the content correspondence is maintained.

I.14.0.2 HI-STORM UMAX System

Important-to-safety activities related to construction and deployment of the HI-STORM UMAX System are controlled under the NRC-approved Holtec Quality Assurance Program. The Holtec QA program manual **Error! Reference source not found.** is approved by the NRC **Error! Reference source not found.** under Docket 71-0784. The Holtec QA program satisfies the

[†] This chapter has been prepared in the format and section organization set forth in Regulatory Guide 3.61.

HOLTEC INTERNATIONAL COPYRIGHTED MATERIAL	
HI-2115090	Proposed Rev. 3.E
I.14-1	

requirements of 10 CFR 72, Subpart G and 10 CFR 71, Subpart H. In accordance with 10 CFR 72.140(d), this approved 10 CFR 71 QA program will be applied to spent fuel storage cask activities under 10 CFR 72. This program is fully described in Chapter 14 of the main body of this FSAR.

I.14.0.3 Cask Handling Apparatus and Top Seismic Restraint Assembly

Important-to-safety activities related to fabrication and deployment of the Cask Handling Apparatus (CHA) and Top Seismic Restraint Assembly (TSRA) are controlled under the same NRC-approved Holtec Quality Assurance Program as the HI-STORM UMAX as described in Subsection I.14.0.2 and the main body of this FSAR.

I.14.0.4 24PT1-DSC

The 24PT1-DSC canisters are designed and fabricated under the TN QA program, as described in Chapter 13 of the NUHOMS FSAR [I.1.2.1]. This QA program is NRC approved, and follows a similar graded “important-to-safety,” classification system as described in the main body of this FSAR for the HI-STORM UMAX System.

HOLTEC INTERNATIONAL COPYRIGHTED MATERIAL	
HI-2115090	Proposed Rev. 3.E
I.14-2	

Table I.14.0.1: Material Incorporated by Reference

Information Incorporated by Reference	Source of the Information	NRC Approval of Material Incorporated by Reference	Location in this FSAR where Material is Incorporated	Technical Justification of Applicability to HI-STORM UMAX
QA Program for 24PT1-DSC canister	Section 13.1 of NUHOMS FSAR [I.1.2-1]	SER Advanced NUHOMS Amendment 0, Reference [I.1.2-2]	Section I.14.0.4	The canisters are designed and fabricated in accordance with the existing TN NRC approved QA program, which is unchanged by their storage in the HI-STORM UMAX System. The HI-STORM UMAX System and its ancillaries are designed, fabricated, and constructed under the Holtec NRC approved QA program.

HOLTEC INTERNATIONAL COPYRIGHTED MATERIAL	
HI-2115090	Proposed Rev. 3.E
I.14-3	